

*Box, No.*

ESSEX INSTITUTE.  
LIBRARY OF FRANCIS PEABODY.

PRESENTED BY

MRS. MARTHA PEABODY.

The Library Committee shall divide the books and other articles belonging to the Library into three classes, namely: (a) those which are not to be removed from the building; (b) those which may be taken only by written permission of three members of the committee; (c) those which may circulate under the following rules:—

Members shall be entitled to take from the Library two folio or quarto volumes, or four volumes of lesser fold, with the plates belonging to the same, upon having them recorded by the Librarian, or Assistant Librarian, and promising to make good any damage they sustain, while in their possession, and to replace the same if lost, or pay a sum fixed by the Library Committee.

No person shall lend any book belonging to the Institute, excepting to a member, under a penalty of one dollar for each offence.

The Library Committee may allow members to take more than the allotted number of books upon a written application, and may also permit other persons than members to use the Library under such conditions as they may impose.

No person shall detain any book longer than four weeks from the Library, if notified that the same is wanted by another member, under a penalty of five cents per day, and no volume shall be detained longer than three months at one time under the same penalty.

The Librarian shall have power by order of the Library Committee to call in any volume after it has been retained by a member for ten days.

On or before the first Wednesday in May, all books shall be returned to the Library, and a penalty of five cents per day shall be imposed for each volume detained.

No book shall be allowed to circulate until one month after its receipt.





ELEMENTS  
OF  
SCIENCE AND ART.

VOL. I.

LONDON:  
Printed by A. & R. Spottiswoode,  
New-Street-Square.

ELEMENTS  
OF  
**SCIENCE AND ART:**

BEING A  
FAMILIAR INTRODUCTION

TO  
*NATURAL PHILOSOPHY AND CHEMISTRY:*

TOGETHER WITH  
THEIR APPLICATION TO A VARIETY OF ELEGANT  
AND USEFUL ARTS.

---

By JOHN IMISON.

---

*A NEW EDITION,*  
Considerably enlarged, and adapted to the improved State of Science,  
By THOMAS WEBSTER, SEC. G. S.

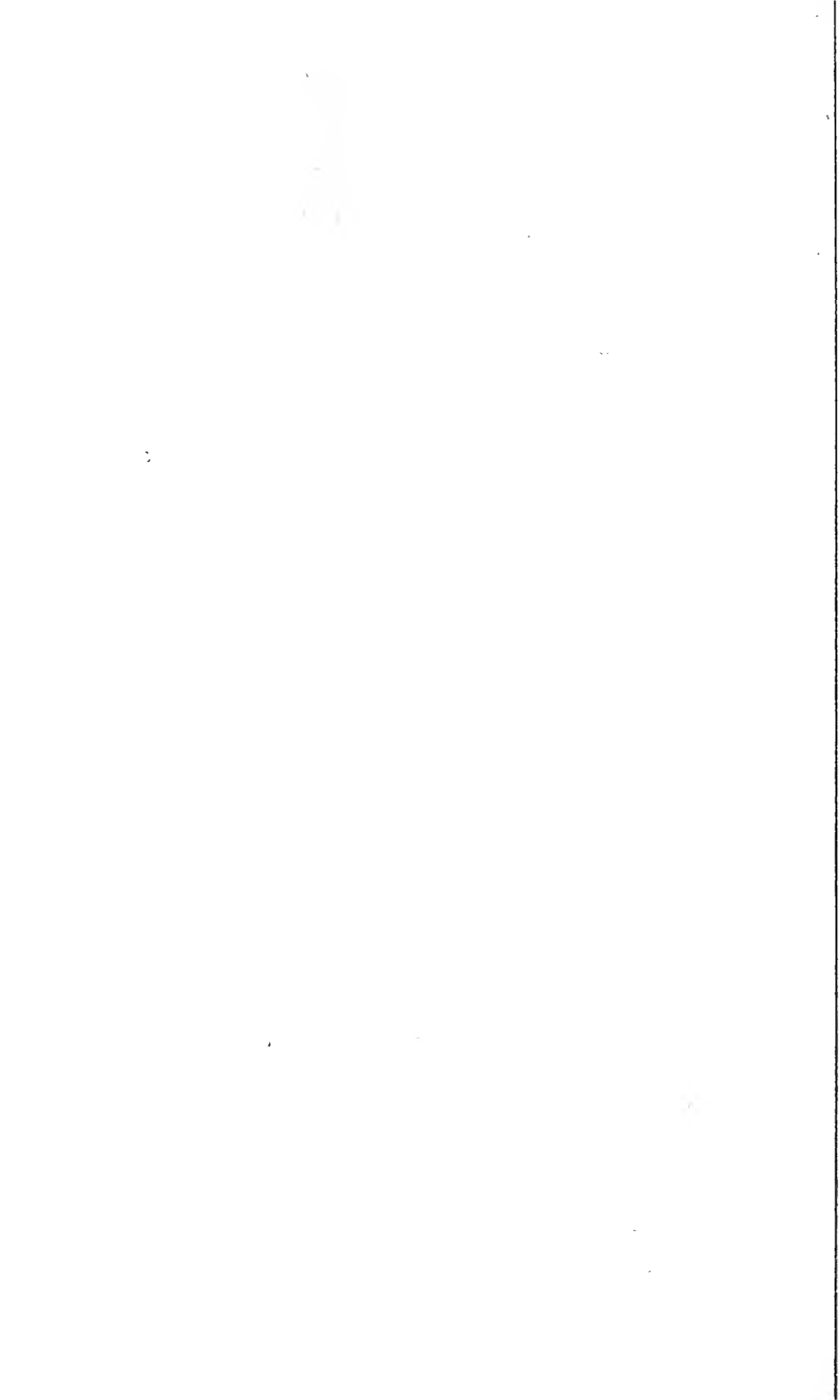
---

IN TWO VOLUMES.  
VOL. I.

LONDON:

PRINTED FOR F. C. AND J. RIVINGTON; J. SCATCHERD; J. NUNN;  
LONGMAN, HURST, REES, ORME AND BROWN; T. CADELL; S. BAGSTER;  
J. BOOTH; J. BOOKER; J. MURRAY; J. RICHARDSON; BALDWIN,  
CRADOCK AND JOY; BAYNES AND SON; J. HARDING; SHERWOOD,  
NEELY AND JONES; G. AND W. E. WHITTAKER; T. TEGG; J. ROBINSON;  
AND E. EDWARDS.

1822.





# PREFACE

*BY THE EDITOR.*

---

THE original work by JOHN IMISON, entitled "The School of Arts," was some years ago put into the hands of the present editor, for the purpose of adapting it to the improved state of Philosophical Science. He engaged in the task the more readily, as he conceived that, by giving a general and concise view of the principles of Natural Philosophy and Chemistry, and of their application to the arts, he might be, in some degree, instrumental in promoting the diffusion of science among persons deprived of the advantages of a regular education.

Having had many opportunities, in the course of his profession, of observing the great use of even a small portion of scientific knowledge to a valuable class of the community, mechanics, he kept it particularly in his view to treat the various subjects, so as to render them as easily intelligible as possible; and, in general, to adapt the explanation of them to that class for which the work was intended by the original author.

In pursuance of this plan, the alterations from the original "School of Arts," and also the additions to it, became so considerable, that the work has assumed nearly the appearance of a new production; and some apology is perhaps due for altering the features of Imison's book so far, that it is no longer recognizeable. In this form it has passed through several editions, a circumstance that induces the hope, that the labour of the present editor has not been altogether useless.

In a book intended to exhibit only the popular elements of science, it would be in vain to expect much original matter. To draw from authentic sources, and to arrange and describe with clearness and precision the principal known facts, appears to be all that the nature of the undertaking admits of. The following work, therefore, is derived from the discoveries of others; but it will be found upon perusal, that in several instances, where the editor's profession or opportunities of observation enabled him to add any thing to the stock of particular knowledge, he has not failed to make the attempt.

With respect to the present edition, he has merely to notice, that a considerable part of it has been re-written; the whole has been revised; and every endeavour has been made to render it a source of entertainment and instruction to those who have not the opportunity of consulting more detailed treatises on the several subjects which are here considered.

T. W.

CONTENTS  
OF  
THE FIRST VOLUME.

---

MECHANICS.

	<i>Page</i>
MATTER and its properties .....	1
Motion.....	7
Attraction .....	12
Centre of gravity .....	20
Repulsion .....	22
Mechanic powers.....	23
The lever.....	24
The wheel and axis.....	36
The pulley .....	41
The inclined plane .....	43
The wedge.....	44
The screw .....	45
Compound machines.....	48
Moving powers in machinery.....	52
Friction .....	57
Communication of motion in machines .....	59
Regulation of motion by fly-wheels .....	62
Of mills.....	67
The pendulum.....	80
Chronometers.....	83
Wheel carriages .....	101
 HYDROSTATICS.....	 107
Of specific gravities .....	117
 PNEUMATICS .....	 126

	<i>Page</i>
The air-pump .....	129
Of condensed air.....	145
The barometer.....	147
Practical directions for using the air-pump.....	152
The air gun .....	157
The diving-bell.....	159
Air balloons.....	162
Of the winds.....	172
 HYDRAULICS .....	 176
The syphon .....	179
Pumps .....	182
Steam engine .....	106
Steam boats.....	225
 OF SOUND.....	 227
 OPTICS.....	 232
Of refraction .....	234
Focal distances of lenses .....	243
Refrangibility of the rays of light .....	247
Description of the eye and nature of vision.....	249
Of spectacles.....	257
Of reflection .....	261
Microscopes .....	271
Telescopes.....	297
The multiplying glass.....	311
Camera obscura .....	312
Magic lantern and phantasmagoria .....	316
 ELECTRICITY.....	 319
Electrical attraction and repulsion.....	324
Of the electric spark .....	328
Influence of points in electricity.....	331
Leyden phial and electric shock.....	335
Electrical battery .....	340
Electrophorus.....	344
Universal discharger .....	345

	<i>Page</i>
Atmospheric electricity .....	346
Miscellaneous experiments.....	352
Practical rules for performing experiments.....	366
Animal electricity.....	373
Medical electricity.....	375
<b>GALVANISM</b> .....	381
<b>MAGNETISM</b> .....	396
Magnetic attraction and repulsion .....	398
Polarity of the magnet .....	401
Dip of the needle.....	403
Communicated magnetism .....	406
<b>ASTRONOMY</b> .....	413

ERRATUM.

P. 76. Vol. II. for BORAX read BORON.

---

TO THE BINDER.

26 Plates, Vol. I., to be placed at the end of the volume.

7 Ditto, Vol. II., at the end of that volume.

# ELEMENTS OF SCIENCE.

---

## MECHANICS.

---

### OF MATTER AND ITS PROPERTIES.

*MATTER*, *substance*, or *body*, is a mode of existence distinguished by its possessing certain known properties, by which it is rendered evident to our senses.

Some sorts of matter are *visible*, or capable of being seen; as wood, stone, &c.; which depends upon the property they have of not permitting the rays of light to pass through them, the rays being reflected to our eyes, as will be seen when we come to treat of optics.

Other bodies are always *invisible*, on account of their perfect transparency; such as the atmospheric air by which we are surrounded, which, though perfectly invisible when dry and pure, yet is substance or matter, as much as the hardest stone.

The existence of other species of matter is still more difficult to perceive, being ascertained only

from their effects in particular states; such as the matter of heat, electricity, &c.; and there may perhaps be kinds of matter that have not yet been discovered. An enumeration of all the known varieties will be found under the article Chemistry.

Every species of matter that has hitherto come under our observation has been found to possess the following characteristics, or properties; and, therefore, we are perhaps justifiable in considering them as belonging to all bodies whatever; viz. *solidity* or *impenetrability*, *divisibility*, and *mobility*.

Some species of bodies have other qualities, which are not common to all; and perhaps matter in general possesses properties which we are yet ignorant of.

When the terms *solidity* and *impenetrability* are used to express one of the properties of matter, they are not taken in the same sense as when opposed to fluidity, but as that property which every body possesses, of not permitting another substance to occupy the same place with it at the same time. If a piece of wood, or stone, occupy a certain space, before you can put another body into that space, you must first remove the stone, or wood; and though fluids, from their nature, do not appear at first to oppose such resistance, yet, in proper circumstances, they will be found to possess this property in an equal degree. Put some water into a tube closed at one end, and insert into it a piston, or piece of wood or metal that perfectly fits the inside; you will find that it will be impossible, by any pressure, to get the piston to the bottom.

If you try the same experiment with the tube empty, (as it is commonly called,) but in reality filled with the air of the atmosphere, you will find



the same impossibility of pushing the piston to the farthest end of the tube; so that both water, and air, and every other fluid, are equally impenetrable, in this sense of the word, with the hardest body.

By solidity, or impenetrability, in common language, is sometimes understood the property of not being easily separated into parts; which is better expressed by the term *hardness*, and is very different from the above meaning.

*Divisibility* is that property by which matter is capable of being separated into parts that can be removed from each other.

This divisibility is evident in bodies of a sensible magnitude. Every one knows that they may be divided into two, four, ten, or a thousand parts; nor can we ever, by subdividing, arrive at a part so small, but we can conceive that it consists of two halves.

Matter is therefore, in imagination, infinitely divisible; but it is the opinion of some philosophers, that the actual divisibility of matter cannot be carried on *ad infinitum*; but that it is constituted of extremely minute atoms or particles, that are not capable of subdivision; these ultimate atoms, if they exist, must be inconceivably small; nor can we by any means ever arrive at them, since any one grain of the finest powder that can be formed by any process consists of an immense number of atoms. Some have supposed that the atoms or molecules of each kind of matter were created distinct from each other, and that they are incapable of alteration or destruction; a collection of each forming the different elementary or simple bodies. By various combinations of these simple bodies, all the varieties that we see are formed.

It is extremely curious to observe to what an amazing extent the actual division of matter may be carried. A grain of gold is hammered by the gold-beaters, until it is the thirty thousandth part of a line in thickness, and will cover fifty square inches. Each square inch may be divided into two hundred strips, and each strip into two hundred parts, each of which may be seen by the eye; consequently a square inch contains forty thousand visible parts, which, multiplied by fifty, the number of square inches which a grain of gold will make, gives two million parts which may be seen by the naked eye. A still more striking instance is afforded by the manufacturer of gold lace. In making this, they gild a bar of silver, and afterwards draw it out into wire, by passing it successively through holes of various magnitudes in plates of steel. By this means, the surface is prodigiously augmented; notwithstanding which, it remains gilded, so as to preserve an uniform appearance, even when examined with the microscope. It has been calculated that sixteen ounces of gold, which, if in the form of a cube, would not measure one inch and a quarter in its side, will completely gild a quantity of silver-wire sufficient to circumscribe the whole globe of the earth.

In animalcules which can be seen only by the microscope, we perceive an organization which is probably accompanied by a circulation of certain fluids, in the same manner as in larger animals. How inconceivably small must then be the particles of their blood or juices through parts of their bodies which are too small to be discerned by the highest magnifiers!

Odoriferous bodies also afford extraordinary

instances of the extreme minuteness of the ultimate atoms of matter.

A single grain of musk will fill for several years with its odour an apartment where the air is often renewed; and if we consider that the musk must send off particles continually to mix with every part of the air of the apartment, it will be readily perceived, that they must be inconceivably minute.

The particles of light also, as will be more particularly explained when we treat of optics, must be small beyond all conception.

*Mobility* means that property by which matter is capable of being moved from one part of space to another.

*Extension* has, by some, been considered as a distinguishing property of matter; but as space is also extended, this cannot be reckoned a characteristic. Mere space differs essentially from matter, having no other property except extension: it may be resolved into parts by the mind, but these parts are not capable of actual separation from each other, and it cannot give any resistance to bodies moving through it.

Besides these, matter possesses a property which is called *inertia*, or inactivity; by which it would always continue in whatever state it was put, whether of rest or motion, unless prevented by some external force.

Most of the bodies with which we are generally acquainted are capable of existing in two distinct states; viz. that of solidity and fluidity.

In solids, the parts cohere together, and the body must be moved in a mass: a block of stone and a piece of wood are familiar instances.

In fluids, the particles are but weakly connected, their mutual cohesion being in a great

measure prevented by some interfering cause. *Fluids* have been defined to be bodies whose parts yield to the smallest force impressed, and by yielding, are easily moved among each other. It should be observed, however, that all fluids offer some resistance to bodies moving through them. The essential difference between the state of solidity and that of fluidity is not accurately known; it has been supposed by some, that the particles of fluids are spherical, and hence admitted of free motion over each other, whilst those of solids are angular, which occasioned an entangling: but solids and fluids are often convertible into each other; as water into ice, metals into a state of fusion, mercury into a solid state by freezing, &c.; and it cannot be supposed that in these cases the figures of the particles are changed.

Others have supposed that the particles of fluids are never in actual contact, being kept apart by caloric, or the matter of heat: this doctrine is rendered plausible, by observing that most solids are rendered fluid by the addition of a sufficient quantity of heat; and, on the contrary, most fluids are reduced to the solid state by its abstraction; but while we are ignorant of the actual form and mode of existence of the particles of matter, this subject must remain extremely obscure.

Fluids are distinguished into non-elastic and elastic. *Non-elastic Fluids* are those whose dimensions are not, at least as to ordinary sense, affected by compression; hence they are also called *incompressible* fluids; such as water, oil, mercury, &c.

Of non-elastic fluids, some are distinguished by the property of *liquidity* or humidity; which implies wetting or adhering to other substances: thus water, oil, milk, &c. are liquids. Melted metals

and mercury, though fluids, have not this property of adhering to bodies in contact with them.

*Elastic fluids*, on the contrary, are those which are reduced into less space by pressure, and which return to their former volume when the pressure is withdrawn; hence they are called also compressible fluids: such are the different kinds of air.

As all bodies seem to possess attraction, in a greater or less degree, it has been considered by some as one of the properties of matter; but this quality does not necessarily enter into our idea of body or substance, as distinguished from mere space; and while we are ignorant of the cause of attraction, and also of the nature of many species of bodies, it would be too much to assume this as necessary to the existence of matter: and we are uncertain whether it be an adventitious quality, or whether it forms one of the essential properties of substance.

#### MOTION.

Motion has been defined to be a change of place, or the act by which a body corresponds with different parts of space at different times. It is by motion alone that we know the existence of bodies, and that a relation is established between them and our senses: all the phenomena of nature, all the changes that happen in the system of bodies, depend immediately upon it; hence modern philosophers have applied themselves with peculiar ardour to investigate its laws.

In considering motion, several circumstances must be attended to.

1. The force which impresses the motion.
2. The direction of the motion.
3. The space passed over by the moving body.

4. The time employed in going over this space.
5. The quantity of matter in the moving body.
6. The force with which it strikes another body that is opposed to it.

In a mechanical sense, every body, by its inertia, resists all change of state. If at rest, it will not begin to move of itself; and if motion is communicated to it by another body, it will continue to move for ever uniformly, except it be stopped by an external agent. It is true, we do not see any instances of bodies continuing to move for ever, after being once put in motion; but the reason of this is, that all the bodies which we see are acted upon in such a manner, as to have their motions gradually destroyed by friction. For if the friction is diminished by any means, the motion will continue much longer; but as it is impossible to destroy friction entirely, it lessens, and at last destroys, all motions on the surface of the earth. A familiar instance may be mentioned to illustrate this tendency of bodies to continue in their present state, whether of rest or motion. If a man be standing in a boat, with his back to the shore when it is pushed off, he is in danger of falling backwards, until he gradually acquires the motion of the boat; and if, after the boat has been in motion some time, it be suddenly stopped, he will fall forwards, because his tendency will then be to continue in a state of motion.

The velocity of motion is estimated by the time employed in moving over a certain space, or by the space moved over in a certain time. The less the time, and the greater the space moved over, the greater is the velocity. To ascertain the degree of this swiftness or velocity, the space run over must be divided by the time. For example, sup-

•

pose a body moves over one thousand yards in ten minutes, its velocity will be one hundred yards per minute; because one hundred is the quotient of one thousand, divided by ten. If we would compare the velocity of two bodies A and B, of which A moves over fifty-four yards in nine minutes, and B ninety-six yards in six minutes, the velocity of A will be that of B in the proportion of six (the quotient of fifty-four divided by nine) to sixteen, (the quotient of ninety-six divided by six.) To know the space run over, the velocity must be multiplied by the time: for it is evident, that if either the velocity or the time be increased, the space run over will be greater. If the velocity be doubled, then the body will move over twice the space in the same time; or if the time be twice as great, then the space will be doubled: but if the velocity and time be both doubled, then will the space be four times as great.

It follows from this, that when two bodies move over unequal spaces in unequal times, their velocities are to each other, as the quotients arising from dividing the spaces run over by the times. If two bodies move over unequal spaces in the same time, their velocities will be in proportion to the spaces passed over. And if two bodies move over equal spaces in unequal times, then their respective velocities will be inversely as the time employed; that is, if A in one minute, and B in two minutes, run over one hundred yards, the velocity of A will be that of B, as two to one.

If a body in motion tend always to the same point, its motion is said to be *rectilinear*, or in a straight line. If it continually changes its direction, it is said to have a *curvilinear* motion.

If a body be acted upon only by one force, or by several in the same direction, its motion will be in the same direction in which the moving force acts; such is the motion of a boat which a man draws to him with a rope. This is called *simple motion*. But if several powers, differently directed, act upon it at the same time, as it cannot obey them all, it will move in a direction somewhere between them; this is denominated *compound motion*.

Suppose a body A (plate 1. fig 1.) to be acted upon by another body in the direction A B; while at the same time it is impelled by another in the direction A C; then it will move in the direction A D; and if the lines A B, A C, be made of lengths proportionate to the forces, and the lines C D, D B, drawn parallel to them, so as to complete the parallelogram A B C D; then the line which the body A will describe, will be the diagonal A D; and the length of this line will represent the force with which the body will move. It is evident, that if a body be impelled by equal forces acting at right angles to each other, that it will move in the diagonal of a square; but whatever may be the direction, or degree of force by which the powers act, the above method will always give the direction and force of the moving body.

It follows from this, that if we know the effect which the joint action of two powers have upon a body, and the force and direction of one of them, it is easy to find that of the other. For suppose A D to be the direction and force with which the body moves, and A B to be one of the impelling forces, then, by completing the parallelogram, the other power A C is found.

Instances in nature, of motion produced by several powers acting at the same time, are innu-



merable. A ship impelled by the wind and tide is well known. A paper kite acted upon by the wind and the string, is another.

A body is said to have an *uniform* motion, when it moves over equal spaces in equal times. Motion is said to be *accelerated*, if its velocity continually increases; to be *uniformly accelerated*, if its velocity increases equally in equal times.

If we suppose a body to be put in motion by a single impulse, and moving uniformly, to receive a new impulse from the same direction, its velocity will be augmented, and it will go on with the augmented velocity. If at each instance of its motion, it receive a new impulse, the velocity will be continually increasing; and if this impulse be always equal, the velocity will be uniformly accelerated.

Motion is said to be *retarded*, if its velocity continually decreases; and to be *uniformly retarded*, if its velocity decreases equally in equal times.

Motion has been also divided into absolute and relative.

*Absolute motion* is the change of absolute place, or the application of a body to different parts of infinite and immoveable space.

*Relative motion* is a change of the situation of the body with respect to other bodies.

These two kinds of motions may be explained in the following manner: were the earth immoveably fixed, then a boat going down a river would be in absolute motion, while a man sitting on the deck would partake of this motion, yet he would not change his situation with respect to the parts of the boat.

Again, if the man were to walk on the deck from the stem to the stern, just as fast as the boat

moved, he would be in motion relatively to the boat, but would not change his situation with respect to the banks of the river, and would, in fact, be absolutely at rest.

But, in strictness, as the earth is in constant motion round its own axis, and also round the sun, all the bodies on its surface can only be considered as relatively at rest, the whole partaking in reality of the motion of the earth. Again, we can only judge of the motion of the earth relatively to the sun, which seems the fixed body; yet it is the opinion of astronomers, that the sun, and perhaps all the stars, are in motion; but we can have no idea of their absolute motion, because we have no knowledge of any heavenly body we can be certain is absolutely at rest, to which we can refer their motions.

Hence we can consider all the motions with which we are acquainted only as relative; absolute motion we have no means of ascertaining.

The *force* with which a body moves, or which it would exert upon another body opposed to it, is always in proportion to its velocity multiplied by its weight or quantity of matter. This force is called the *momentum* of the body; for if two equal bodies move with different velocities, it is evident that their forces, or momenta, are as their velocities; and if two bodies move with the same velocity, their momenta are as their quantities of matter; therefore, in all cases, their momenta must be as the products of their quantities of matter and their velocities. This rule is the foundation of mechanics.

#### ATTRACTION.

By *attraction*, we mean the tendency that bodies have to approach each other

Attraction is distinguished into various kinds; but as the causes of each are entirely unknown, it is uncertain whether some of them be not different modifications of the same.

They are, the attraction of *cohesion*, of *gravitation*, of *electricity*, of *magnetism*, and *chemical attractions*.

The attraction of *cohesion* takes place between bodies only, when they are at such very small distances from each other, that they appear to the eye to be in contact.

If two pieces of lead be scraped clean with a knife, and squeezed together, they will adhere so firmly, that they can scarcely be separated. The same will take place with planes of glass, or marble, which have been wetted with water.

It is probably the various degrees of cohesion which different sorts of matter possess, that give their relative degrees of tenacity or hardness.

The attraction of solids acting on fluids at very small distances constitutes *capillary* attraction. If a glass tube with a fine bore be held perpendicularly in water, it will be perceived that the water will rise in the tube above the level of that in the vessel: and if a number of tubes having bores of different diameters be used together, it will be seen that the water will rise highest in the tube with the smallest bore. Also, if two pieces of glass be kept perpendicularly, and very near to each other in water, the fluid will rise between the glasses. This is owing to the attraction of the glass which acts upon the water. If a woollen thread be hung over the edge of a basin full of water, the water will be attracted by the thread, and made to flow over in drops.

It is by this attraction that the sap rises in trees and plants, and that water will ascend in a sponge, or other porous substance.

The attraction of *gravitation* or *gravity* is the force which all the masses of matter exert upon each other at all distances.

The reason why a body falls to the ground was long unknown, and it was Sir Isaac Newton who first accounted for it, by the attraction of gravitation.

This idea is said to have occurred to him, on observing an apple fall whilst sitting in his garden, which is a striking instance of the use to which a man of genius turns every observation he makes: he supposed that the stone fell towards the earth, because it was drawn, or *attracted* by it. By reflecting upon this principle, he extended it to account for many of the phenomena which till then could not be explained.

It is now considered as one of the laws of nature, that every particle of matter is endued with an attractive power, which it exerts at all distances on every other particle, though the attraction diminishes in proportion to the distance.

By this attraction, the heavenly bodies are retained in their places by their action on each other; the planets and comets all gravitating towards the sun and towards each other, as well as the sun towards them, and that in proportion to the quantity of matter in each.

If two bodies, which contain equal quantities of matter, were placed at ever so great a distance from one another, and then left at liberty in free space, and if there were no other bodies in the universe to affect them, they would fall equally swift towards each other, and would meet in a point which was half way between them at first. Or if two bodies,

containing unequal quantities of matter, were placed at any distance, and left in the same manner at liberty, they would fall towards one another with velocities which would be in an inverse proportion to their respective quantities of matter; and moving faster and faster in their mutual approach, would at last meet in a point as much nearer to the place from which the heavier body began to fall, than to the place from which the lighter began to fall, as the quantity of matter in the former exceeded that in the latter.

The earth attracts all bodies on its surface, and they are all drawn towards the center of the earth; consequently bodies fall every where perpendicular to its surface, and therefore in opposite directions on opposite sides of the earth. As it acts upon all bodies in proportion to their quantities of matter, it is this attractive force that constitutes the *weight* of bodies.

In all places equidistant from the center of the globe, the force of gravity is equal: but this power is greatest at the earth's surface, from whence it decreases both upwards and downwards, but not both ways in the same proportion; for, upwards, the force of gravity decreases as the square of the distance from the centre increases; so that at a double distance from the centre above the surface, the force would be only one fourth of what it is at the surface: but below the surface of the earth, the power decreases in such a manner that its intensity is directly as the distance from the centre, and not as the square of the distance; so that at the distance of half a semi-diameter from the centre, the force would be but half what it is at the surface; at one third of the semi-diameter, the force would be one third, and so on.

As all bodies gravitate towards the earth, so does the earth gravitate towards all bodies, as well as bodies to particular parts of the earth, as has been proved by the attraction which mountains exhibit on a plumb-line, drawing it towards them so that it does not tend exactly to the centre of the earth.

The cause of gravity is totally unknown.

It is observed that bodies fall to the earth with a velocity constantly increasing, which is an instance of accelerated motion caused by the constant action of gravity.

To illustrate this, let us suppose the time of descent of a falling body to be divided into a number of very small equal parts; the impression of gravity in the first instant would make the body descend with a proportionate and uniform velocity; but in the second instant, the body, receiving a new impulse from gravity in addition to the first, would move with twice the velocity as before; in the third instant, it would have three times the velocity, and so on.

To illustrate the doctrine of accelerated motion, let us suppose that, in the triangle  $A B C$ , (Plate 1. fig 2.)  $A B$  expresses the time which a body takes to fall, and  $B C$  the velocity acquired at the end of the fall. Let  $A B$  be divided into a number of equal parts indefinitely small, and from each of these divisions suppose lines, as  $D E$ , drawn parallel to  $B C$ ; it is evident from what has been said, that those lines will express the velocities of the falling body in the several respective points of time, each being greater than the other, by a certain quantity of increase, which follows from the nature of the triangle. Now, the spaces described in the same time are in proportion to the velocities; and the sum of the spaces described in all the small portions

of time is equal to the space described from the beginning of the fall. But the sum of all lines parallel to  $BC$ , taken indefinitely near to each other, constitutes the area of the triangle. Therefore the space described by a falling body, in the time expressed by  $AB$ , with an uniformly accelerated velocity, of which the last degree is expressed by  $BC$ , will be represented by the area of the triangle  $ABC$ .

Let us now suppose, that gravity ceased to act, and that the body moved during another portion of time,  $BF$ , equal  $AB$ , with the acquired velocity represented by  $BC$ . As the space moved over is found by multiplying the velocity by the time, the rectangle  $BCFG$  will represent the space moved over in this second portion of time, which is twice the triangle  $ABC$ ; and consequently twice the space is moved over with the accelerating velocity in the same time.

But if we suppose gravity still to act, besides the space  $BCFG$ , which it would have moved over by its acquired velocity, we must add the triangle  $CGH$  for the effect of the constant action of gravity; therefore, in this second portion of time, the body moves over three times the space as in the first. In like manner, it may be easily seen by the figure, that in the next portion it would move over five times the space; in the next, seven times the space; and so on in arithmetical progression. And as the velocities of falling bodies are in proportion to the spaces run over, it follows that the velocities in each instant increase as the numbers 1, 3, 5, 7, 9, &c.

It follows from this, that the space run over is as the square of the time; that is, in twice the time, a body will fall with four times the velocity; in

thrice the time, with nine times the velocity, &c.; for, in the first time, there was but one space run over; the square of 1 is 1; at the end of the second time there are four spaces run over, one in the first, and three in the second; the square of 2 is 4: at the end of the third time, there are nine spaces run over; the square of 3 is 9: and so on. This may be seen in the figure.

It is found by experiment, that a body falling from a height moves at the rate of  $16\frac{1}{7}$  feet in the first second; and, as has been shown above, acquires a velocity of twice that, or  $32\frac{1}{6}$  feet in a second. At the end of the next second, it will have fallen  $64\frac{1}{3}$  feet, the space being as the square of the time: the square of 2 is 4, and 4 times  $16\frac{1}{7}$  is  $64\frac{1}{3}$ . By the same rule it may be found, that in the third second it will fall 144 feet; in the next 256 feet, and so on. It is to be understood, however, that by this velocity is meant, what bodies would acquire, if they were to fall through a space where there was no air; for its resistance considerably diminishes their velocity in falling.

It has been already shown, that if two forces act uniformly upon a body, they will cause it to move in a straight line; but if one only, or both, continually change their direction, or intensity of force, the body will describe a curve. If one of the forces uniformly impel the body in a straight line, while the other uniformly draws it towards a centre, the body will move in a circle: an example of which is seen in a stone in a sling that is swung round by the hand. If at any point of the revolution one of the forces should cease to act, then the body will obey the other force; if, for instance, the string be let go, the stone will fly off in a straight line, which will be a tangent to the circle in which it moved.



It is this tendency to recede from the centre which is called the *centrifugal force*: the power which draws it to the centre is called the *centripetal force*.

If the direction of the forces continue the same, and if one of them is accelerating or retarding, the body will likewise describe a curve. Thus if a ball be projected from a cannon, it receives an impulse, which, if there was no resistance from the air, and if it were not acted upon by gravity, would cause it to move always in a straight line: but as soon as it leaves the mouth of the cannon, gravity acts upon it in a direction perpendicular to the ground, and continuing to do so, becomes an uniformly accelerating force: hence the ball comes at length to the ground, having described in a course a curved line.

If the air were wanting, it can be calculated that this curve would be a parabola; and this is the foundation of the theory of *projectiles* and the art of gunnery. But the resistance of the air and other causes occasion projected bodies to deviate considerably from the parabolic curve, and render it more difficult than it would otherwise be to calculate the distance to which they may be sent.

Although it has been stated above, that probably all bodies have attraction, yet in several acknowledged species of matter no weight is discoverable. Matter has accordingly been divided also into *ponderable* and *imponderable*.

The first consists of all known solid bodies and non-elastic fluids, together with air or gas, all of which have a sensible weight or gravity. The second includes caloric or the matter of heat, light, electricity, the magnetic fluid, &c.; none of which can be discovered to

have any weight. But it should be noticed, that we are not yet sufficiently acquainted with this latter class: among modern philosophers, there are various opinions even as to their existence as distinct species of matter, some considering the phenomena occasioned by them as arising from various modifications of motion only.

#### CENTRE OF GRAVITY.

The centre of gravity of a body is that point about which all its parts exactly balance each other.

Hence if a body be suspended or supported by this point, it will rest in any position into which it is put. Also, whatever supports that point bears the weight of the whole body; and while it is supported, the body cannot fall. We may therefore consider the whole weight of a body as centred in this point.

The common centre of gravity of two or more bodies is the point about which they would equi-ponderate or rest in any position. If the centres of gravity of two bodies, A and B, (Plate 1. fig. 3.) be connected by the right line A B, the distances A C, and B C, from the common centre of gravity C, are reciprocally as the weights or bodies A and B; that is,  $A C : B C :: B : A$ .

If a line be drawn from the centre of gravity of a body, perpendicular to the horizon, it is called the *line of direction*, because it is the line that the centre of gravity would describe if the body fell freely.

It is the property of this line, that while it falls within the base upon which the body stands, the body cannot fall; but if it fall without the base,

the body will tumble. Thus the inclining body  $A B C D$  (fig. 4.) whose centre of gravity is  $E$ , stands firmly on its base  $C D I K$ , because the line of direction  $E F$  falls within the base. But if a weight, as  $A B G H$ , be laid upon the top of the body, the centre of gravity of the whole body and weight together is raised to  $L$ : and then, as the line of direction  $L D$  falls without the base at  $D$ , the centre of gravity is not supported, and the whole body and weight will tumble down together.

Hence appears the absurdity of people's rising hastily in a coach or boat, when it is likely to overset; for by that means, they raise the centre of gravity so far as to endanger throwing it quite out of the base, and if they do, they overset the vehicle effectually: whereas, had they kept down to the bottom, they would have brought the line of direction, and consequently the centre of gravity, farther within the base, and by that means might have saved themselves.

The broader the base, and the nearer the line of direction is to the middle or centre of it, the more firmly does the body stand. On the contrary, the narrower the base, and the nearer the line of direction is to the side of it, the more easily may the body be overthrown; a less change of position being sufficient to remove the line of direction out of the base in the latter case than in the former. And hence it is, that a sphere is so easily rolled upon a horizontal plane; and that it is so difficult, if not impossible, to make things which are sharp-pointed, to stand upright on the point.

From what has been said, it plainly appears, that if the plane on which a heavy body is placed, be inclined, the body will slide down upon the plane, whilst the line of direction falls within the

base; but it will tumble or roll down, when that line falls without the base. Thus the body E (fig. 5.) will only slide down the inclined plane CD, whilst the body B rolls down upon it.

When the line of direction falls within the base of our feet, we stand, and most firmly, when it is in the middle; but when it is out of the base, we immediately fall. And it is amusing to reflect upon the various methods and postures which we use, to retain this position, or to recover it when lost, without our being sensible of it. Thus we bend our body forward when we rise from a chair, or when we go up stairs; and for this purpose a man leans forward when he carries a burden upon his back, and backward when he carries it on his breast; and to the right or left side, as he carries it on the opposite side.

Many of the feats of balancing depend solely upon this principle.

#### REPULSION.

As observation has shewn us, that there are powers in nature, by which not only the larger masses, but also the smaller portions of matter have a general tendency to approach each other, so the same experience convinces us that matter is, in some cases, endowed with a repulsive power, by which the parts recede or fly off from each other. Striking instances of this may be seen in the magnet, when the disagreeing poles are presented to each other; and also in electricity. It would appear that all, or most bodies, are surrounded by a power of repulsion, by which they are prevented from being in actual contact, even when they appear to the sight to touch: and it may be calculated, that it requires a considerable

pressure to overcome this repulsion, so as to make bodies really touch each other. Sir Isaac Newton states, that when two pieces of glass are placed so as to appear to be in contact, they are still distant from each other  $\frac{1}{100000}$  of an inch; and that by pressure this distance is diminished, although perhaps the contact is never quite perfect.

Oil and water seem to repel each other; and when drops of rain run over green cabbage leaves, it may be seen that there is no actual contact, from the light that is reflected from the under surface of the drop, and from the leaf not being wetted. Many other familiar instances might be adduced of the existence of a repulsive power. Its laws are less known than those of attraction, and its cause is equally obscure.

### MECHANIC POWERS.

The mechanical powers are simple instruments by which men are enabled to raise weights, move heavy bodies, and overcome resistances, which they could not do with their natural strength alone.

These simple machines are six in number: the *lever*, the *pulley*, the *wheel and axis*, the *inclined plane*, the *wedge*, and the *screw*; and of combinations of these all mechanical engines consist.

To calculate the effect produced by these, as well as by all other machines, it is necessary, first, to consider what must be the *power* to keep the *weight* or *resistance* in a state of *equilibrium* or balance: and for this purpose, in the theoretical part of the calculation, all planes are considered as perfectly smooth; levers to be inflexible, and without thickness or weight; cords perfectly pliable, and without diameter; and machines to have

no friction or inertia. When this equilibrium is established, it will be then necessary to add so much more power as will be sufficient to overcome the friction of the machine, and to give the requisite velocity.

#### THE LEVER.

The lever is the simplest of all machines, and is only a straight bar of iron, wood, or other material, supported on, and moveable round, a prop called the *fulcrum*.

In the lever, there are three circumstances to be principally attended to: 1. The *fulcrum*, or prop, by which it is supported, or on which it turns as an axis, or centre of motion: 2. The *power* to raise and support the weight: 3. The *resistance* or weight to be raised or sustained.

The points of suspension are those points where the weights really are, or from which they hang freely.

The power and the weight are always supposed to act at right angles to the lever, except it be otherwise expressed.

The lever is distinguished into three sorts, according to the different situations of the fulcrum and the power, with respect to each other.

1. When the fulcrum is placed between the power and the weight.

2. When the fulcrum is at one end of the lever, the power at the other, and the weight between them.

3. When the fulcrum is at one end, the weight at the other, and the power applied between them.

A poker, in stirring the fire, is a lever of the first sort; the bar of the grate upon which it rests is the fulcrum; the fire, the weight to be overcome; and the hand is the power. The lever of the first kind is principally used for loosening large stones;

or to raise great weights to small heights, in order to get ropes under them, or other means of raising them to still greater heights.

A B C (Plate 1. fig. 6.) is this lever; in which B is the fulcrum, A the end at which the power is applied, and C the end where the weight acts.

To find when an equilibrium will take place between the power and the weight, in this as in every other species of lever, it is necessary to recur to what has formerly been mentioned, that when the momenta, or quantities of force, in two bodies were equal, they would balance each other. Now, let us consider when this will take place in the lever. Suppose the lever A B (fig. 7.) to be turned on its axis, or fulcrum, so as to come into the situation D C; as the end D is farthest from the centre of motion, and as it has moved through the arch A D in the same time as the end B moved through the arch B C, it is evident that the velocity of A B must have been greater than that of B. But the momenta being the products of the quantities of matter multiplied into the velocities, the greater the velocity, the less the quantity of matter need be to get the same product. Therefore, as the velocity of A is the greatest, it will require less matter to produce an equilibrium than B.

Let us next see how much more weight B will require than A, to balance. As the radii of circles are in proportion to their circumferences, they are also proportionate to similar parts of them; therefore, as the arches A D, C B, are similar, the radius, or arm, D E, bears the same proportion to E C that the arch A D bears to C B. But the arches A D and C B represent the velocities of the ends of the lever, because they are the spaces which they moved over in the same time; therefore

the arms  $D E$  and  $E C$  may also represent these velocities.

It is evident then, that an equilibrium will take place, when the length of the arm  $A E$  multiplied into the power  $A$ , shall equal  $E B$  multiplied into the weight  $B$ ; and consequently, that the shorter  $E B$  is, the greater must be the weight  $B$ ; that is, the power and the weight must be to each other inversely as their distances from the fulcrum. Thus, suppose  $A E$ , the distance of the power from the prop, to be twenty inches; and  $E B$ , the distance of the weight from the prop, to be eight inches; also the weight to be raised at  $B$  to be five pounds; then the power to be applied at  $A$  must be two pounds; because the distance of the weight from the fulcrum eight, multiplied into the weight five, makes forty; therefore twenty, the distance of the power from the prop, must be multiplied by two, to get an equal product; which will produce an equilibrium.

It is obvious, that while the distance of the power from the fulcrum exceeds that of the weight from the fulcrum, a power less than the weight will raise it, so that then the lever affords a mechanical advantage: when the distance of the power is less than that of the weight from the prop, the power must be greater than the weight to raise it; when both the arms are equal, the power and the weight must be equal, to be in equilibrio.

The second kind of lever, when the weight is between the fulcrum and the power, is represented by Plate 1. fig 8. in which  $A$  is the fulcrum,  $B$  the weight, and  $C$  the power. The advantage gained by this lever, as in the first, is as great as the distance of the power from the prop exceeds the distance of the weight from it. Thus, if the point  $a$ ,



on which the power acts, be seven times as far from A as the point Z, on which the weight acts, then one pound applied at C will raise seven pounds at B.

This lever shews the reason why two men carrying a burden upon a stick between them, bear shares of the burden which are to one another in the inverse proportion of their distances from it. For it is well known, that the nearer either of them is to the burden, the greater share he bears of it; and if he go directly under it, he bears the whole. So if one man be at A, and the other at *a*, having the pole or stick resting on their shoulders; and if the burden or weight B be placed five times as near the man at A, as it is to the man at *a*, the former will bear five times as much weight as the latter.

This is likewise applicable to the case of two horses of unequal strength being so yoked, as that each horse may draw a part proportionable to his strength; which is done by so dividing the beam they pull, that the point of traction may be as much nearer to the stronger horse than to the weaker, as the strength of the former exceeds that of the latter.

To this kind of lever may be reduced oars, rudders of ships, doors turning upon hinges, cutting-knives which are fixed at the point, &c.

If in this lever we suppose the power and weight to change places, so that the power may be between the weight and the prop, it will become a lever of the third kind; in which, that there may be a balance between the power and the weight, the intensity of the power must exceed the intensity of the weight just as much as the distance of the weight from the prop exceeds the distance of

the power. Thus, let E (fig. 9.) be the prop of the lever E F, and W a weight of one pound, placed three times as far from the prop as the power P acts at F, by the cord going over the fixed pulley D: in this case, the power must be equal to three pounds, in order to support the weight of one pound.

To this sort of lever are generally referred the bones of a man's arm; for when he lifts a weight by the hand, the muscle that exerts its force to raise that weight is fixed to the bone about one-tenth part as far below the elbow as the hand is. And the elbow being the centre round which the lower part of the arm turns, the muscle must therefore exert a force ten times as great as the weight that is raised.

Since in this kind of lever there is a loss of power, it is used only through convenience; as in the case of raising a ladder, which being fixed at one end, is by the strength of a man's arms reared against a wall.

What is called the *hammer-lever* differs in nothing but its form from a lever of the first kind. Its name is derived from its use, that of drawing a nail out of wood by a hammer.

Suppose the shaft of a hammer to be five times as long as the iron part which draws the nail, the lower part resting on the board as a fulcrum; then, by pulling backwards the end of the shaft, a man will draw a nail with one-fifth part of the power that he must use to pull it out straight with a pair of pincers; in which case, the nail would move as fast as his hand; but with the hammer, the hand moves five times as much as the nail, by the time that the nail is drawn out.

Let  $A C B$  (fig. 10.) represent a lever of this sort, bended at  $C$ , which is its prop, or centre of motion.  $P$  is a power acting upon the longer arm  $A C$ , at  $A$ , by the means of the cord  $D A$  going over the pulley  $D$ ; and  $W$  is a weight or resistance acting upon the end  $B$  of the shorter arm  $C B$ . If the power be to the weight as  $C B$  is to  $C A$ , they are in equilibrio: thus, suppose  $W$  to be five pounds, acting at the distance of one foot from the centre of motion  $C$ , and  $P$  to be one pound, acting at  $A$ , five feet from the centre  $C$ , the power and weight will just balance each other.

Thus we see, that in every species of lever there will be an equilibrium, when the power is to the weight as the distance of the weight from the fulcrum is to the distance of the power from the fulcrum.

In making experiments with models of the mechanic powers, some difficulties arise from the weight of the materials; but as it is impossible to find any that are without weight, care must be taken that they are perfectly balanced, before the weights and powers are applied. Thus the bar, used in making experiments on levers, has the short end so much thicker than the long arm, as will be sufficient to balance it on the prop.

If the weight to be raised be of considerable bulk, and if it be fixed either above or below the end of the lever, it will vary in its intensity, according to the position of the lever. Let  $A B$  (fig. 11.) represent a lever having a weight fixed above it, as  $A$ , of which the centre of gravity is  $a$ , and the line of direction  $a b$ ; then is  $b$  the point in the lever on which the weights acts: but if the lever be moved into the position  $C D$ , the line of direction of the weight will fall nearer to the ful-

crum of the lever, and consequently act with less force upon it; but if it be placed in the position E F, the line of direction will fall farther from the fulcrum, and therefore act more on the lever.

On the contrary, it is evident from fig. 12. that opposite effects take place, when the weight is below the lever.

Nothing of this kind can happen, when the weight is suspended from the lever by a rope, because the point of suspension, or point of action, is not altered.

When two draymen carry a barrel on a coulstaff, to which it is suspended by a chain, the point on which the weight acts not being altered by inclining the staff in going up or down hill, there will be no variation in the weight that each man had to support on beginning. But if they carry the barrel upon two dogs, then the weight does not swing, and the centre of gravity is below the lever; therefore the point on which the weight acts, will, by inclining the lever, be made to approach the highest end; and the first man, in going down hill, by having this point removed from him, will be eased in part of his burden; and the last man will have his equally increased.

Hitherto we have supposed that the power and weight acted perpendicularly upon the lever; but if they do not, they act with less force upon it; the power should, therefore, if possible, be always made to act at right angles to the lever.

If several levers be combined together in such a manner, as that a weight being appended to the first lever, may be supported by a power applied to the last, as in Plate 1. fig. 13. which consists of three levers of the first kind, and is so contrived, that a power applied at the point L of the lever C,

may sustain a weight at the point *S* of the lever *A*, the power must here be to the weight in a ratio, or proportion, compounded of the several ratios which those powers that can sustain the weight by the help of each lever, when used singly and apart from the rest, have to the weight. For instance, if the power which can sustain the weight *P*, by the help of the lever *A*, be to the weight as 1 to 5; and if the power which can sustain the same weight, by the lever *B* alone, be to the weight as 1 to 4; and if the power which could sustain the same weight by the lever *C*, be to the weight as 1 to 5; then the power which will sustain the weight by help of the three levers joined together, will be to the weight in a proportion consisting of the several proportions multiplied together, of 1 to 4, and 1 to 5; that is, of 1 to 100.

For since, in the lever *A*, a power equal to one-fifth of the weight *P* pressing down the lever at *L*, is sufficient to balance the weight, and since it is the same thing whether that power be applied to the lever *A* at *L*, or the lever *B* at *S*, the point *S* bearing on the point *L*, a power equal to one-fifth of the weight *P*, being applied to the point *S* of the lever *B*, will support the weight; but one-fourth of the same power being applied to the point *L* of the lever *B*, and pushing the same upward, will as effectually depress the point *S* of the same lever, as if the whole power were applied at *S*; consequently a power equal to one-fourth of one-fifth, that is, one-twentieth of the weight *P*, being applied to the point *L* of the lever *B*, and pushing up the same, will support the weight: in like manner, it matters not whether that force be applied to the point *L* of the lever *B*, or to the point *S* of the lever *C*, since, if *S* be raised, *L*,

which rests on it, must be raised also ; but one-fifth of the power applied at the point L of the lever C, and pressing it downwards, will as effectually raise the point S of the same lever, as if the whole power were applied at S, and pushed up the same ; consequently a power equal to one-fifth of one-twentieth, that is, one-hundredth part of the weight P, being applied to the point L of the lever C, will balance the weight at the point S of the lever A.

This method of combining levers is frequently used in machines and instruments, and is of great service, either in obtaining a greater power, or in applying it with more convenience.

The *balance*, an instrument of very extensive use in comparing the weights of bodies, is a lever of the first kind, whose arms are of equal length. The points from which the weights are suspended, being equally distant from the centre of motion, will move with equal velocity ; consequently, if equal weights be applied, their momenta will be equal, and the balance will remain in equilibrio.

In order to have a balance as perfect as possible, it is necessary to attend to the following circumstances :

1. The arms of the beam ought to be exactly equal, both as to weight and length.

2. The points from which the scales are suspended should be in a right line passing through the centre of gravity of the beam ; for by this, the weights will act directly against each other, and no part of either will be lost on account of any oblique direction.

3. If the fulcrum, or point upon which the beam turns, be placed in the centre of gravity of the beam, and if the fulcrum, and the points of suspen-

sion be in the same right line, the balance will have no tendency to one position more than another, but will rest in any position it may be placed in, whether the scales be on or off, empty or loaded.

If the centre of gravity of the beam, when level, be immediately above the fulcrum, the beam will overset by the smallest action ; that is, the end which is lowest will descend ; and it will do this with more swiftness, the higher the centre of gravity be, and the less the points of suspension be loaded.

But if the centre of gravity of the beam be immediately below the fulcrum, the beam will not rest in any position but when level ; and if disturbed from that position, and then left at liberty, it will vibrate, and at last come to rest on the level. In a balance, therefore, the fulcrum ought always to be placed a little above the centre of gravity. Its vibrations will be quicker, and its horizontal tendency stronger, the lower the centre of gravity, and the less the weight upon the points of suspension.

4. The friction of the beam upon the axis ought to be as little as possible ; because, should the friction be great, it will require a considerable force to overcome it ; upon which account, though one weight should a little exceed the other, it will not preponderate, the excess not being sufficient to overcome the friction, and bear down the beam. The axis of motion should be formed with an edge like a knife, and made very hard : these edges are at first made sharp, and then rounded with a fine hone, or piece of buff leather, which causes a sufficient bluntness, or rolling edge. On the regular form and excellence of this axis depends chiefly the perfection of this instrument.

5. The pivots, which form the axis or fulcrum, should be in a straight line, and at right angles to the beam.

6. The arms should be as long as possible, relatively to their thickness, and the purposes for which they are intended; as the longer they are, the more sensible is the balance.

They should also be made as stiff and inflexible as possible; for if the beam be too weak, it will bend, and become untrue.

7. The rings, or the pieces on which the axis bears, should be hard and well polished, parallel to each other, and of an oval form; that the axis may always keep its proper bearing, or remain always at the lowest point.

8. If the arms of a balance be unequal, the weights in equipoise will be unequal in the same proportion. The equality of the arms is of use, in scientific pursuits, chiefly in the making of weights by bisection. A balance with unequal arms will weigh as accurately as another of the same workmanship with equal arms, provided the standard weight itself be first counterpoised, then taken out of the scale, and the thing to be weighed be put into the scale, and adjusted against the counterpoise. Or, when proportional quantities only are considered, the bodies under examination may be weighed against the weights, taking care always to put the weights in the same scale; for then, though the bodies may not be really equal to the weights, yet their proportions amongst each other will be the same as if they had been accurately so.

9. Very delicate balances are not only useful in nice experiments, but are likewise much more expeditious than others in common weighing. If a pair of scales with a certain load be barely sensible



to one-tenth of a grain, it will require a considerable time to ascertain the weight to that degree of accuracy, because the turn must be observed several times over, and is very small. But if no greater accuracy were required, and scales were used which would turn with one-hundredth of a grain, a tenth of a grain more or less would make so great a difference in the turn, that it would be seen immediately.

10. If a balance be found to turn with a certain addition, and is not moved by any smaller weight, a greater sensibility may be given to the balance by producing a tremulous motion in its parts. Thus, if the edge of a blunt saw, a file, or other similar instrument, be drawn along any part of the case or support of the balance, it will produce a jarring which will diminish the friction in the moving parts so much, that the turn will be evident with one-third, or one-fourth of the addition that would else have been required. In this way, a beam, which would barely turn by the addition of the tenth of a grain, will turn with the thirtieth or fortieth of a grain.

To those who are engaged in making nice philosophical experiments, an accurate balance is of the greatest importance. One of the best ever made is that belonging to the Royal Society, executed by the late Mr. Ramsden.

The *statera*, or *Roman steel-yard*, is a lever of the first kind; and is used for finding the weights of different bodies, by one single weight placed at different distances from the prop or centre of motion D (fig. 14.) The shorter arm D G is of such a weight as exactly to counterpoise the longer arm D X. If this arm be divided into as many

equal parts as it will contain, each equal to  $GD$ , the single weight  $P$  (which we may suppose to be one pound) will serve for weighing any thing as heavy as itself, or as many times heavier as there are divisions in the arm  $DX$ , or any quantity between its own weight and that quantity. As for example, if  $P$  be one pound, and placed at the first division 1 in the arm  $DX$ , it will balance one pound in the scale at  $W$ ; if it be removed to the second division at 2, it will balance two pounds in the scale; if to the third, three pounds; and so on to the end of the arm  $DX$ . If any of these integral divisions be subdivided into as many equal parts as a pound contains ounces, and the weight  $P$  be placed at any of these subdivisions, so as to counterpoise what is in the scale, the pounds and odd ounces therein will by that means be ascertained.

#### THE WHEEL AND AXIS.

This mechanic power consists of a wheel with an axis or axle fixed to it, so as to turn round with it; the power being applied at the circumference of the wheel, the weight to be raised is fastened to a rope which coils round the axle.

$AB$  (Plate 2. fig. 1.) is a wheel, and  $CD$  an axis fixed to it, and which moves round with it. If the rope which goes round the wheel be pulled, and the wheel turned once round, it is evident that as much rope will be drawn off as the circumference of the wheel; but while the wheel turns once round, the axis turns once round; and consequently the rope by which the weight is suspended will wind once round the axis, and the weight will be raised through a space equal to the circumference of the axis.

The velocity of the power, therefore, will be to that of the weight, as the circumference of the wheel to that of the axis.

That the power and the weight may be in equilibrio, therefore, the power must be to the weight as the circumference of the wheel to that of the axis.

It is proved by geometry, that the circumferences of different circles bear the same proportion to each other as their respective diameters do; consequently the power is to the weight, as the diameter also of the axis to that of the wheel.

Thus, suppose the diameter of the wheel to be eight inches, and the diameter of the axis to be one inch; then one ounce acting as the power  $P$  will balance eight ounces as a weight  $W$ ; and a small additional force will cause the wheel to turn with its axis, and raise the weight; and for every inch which the weight rises, the power will fall eight inches.

The wheel and axis may be considered as a kind of perpetual lever, of which the fulcrum is the centre axis, and the long and short arms the diameter of the wheel and the diameter of the axis. See Plate 2. fig. 2.

From this it is evident, that the longer the wheel, and the smaller the axis, the stronger is the power of this machine; but then the weight must rise slower in proportion.

A *capstan* is a cylinder of wood, with holes in it, into which are put bars, or levers, to turn it round; these are like the spokes of a wheel without the rim.

Sometimes the axis is turned by a winch fastened to it, which, in this respect, serves for a

wheel, and is more powerful, in proportion to the largeness of the circle it describes, compared with the diameter of the axis.

When the parts of the axis differ in thickness, and weights are suspended at the different parts, they may be sustained by one and the same power applied to the circumference of the wheel, provided the product arising from the multiplication of the power into the diameter of the wheel, be equal to the sum of the products arising from the multiplication of the several weights into the diameters of those parts of the axis from which they are suspended.

In considering the theory of the wheel and axis, we have supposed the rope that goes round the axis to have no sensible thickness; but, as in practice this cannot be the case, if it be a thick rope, or if there be several folds of it round the axis, we must measure to the middle of the outside rope, to obtain the diameter of the axis; for the distance of the weight from the centre is increased by the coiling up of the rope.

If teeth be cut in the circumference of a wheel, and if they work in the teeth of another wheel of the same size as Plate 2. fig. 3. it is evident that both the wheels will revolve in the same time; and the weight appended to the axis of the wheel B will be raised in the same time as if the axis had been fixed to the wheel A. But if the teeth of the second wheel be made to work in teeth made in the axis of the first, as at fig. 4., since every part of the circumference of the second wheel is applied successively to the circumference of the axle of the first, and since the former is much greater than the latter, it is evident that the first wheel must go round as many times more than the second, as the

circumference of the second wheel exceeds that of the first axis.

In order to a balance here, the power must be to the weight, as the product of the circumferences, or diameters of the two axes multiplied together, is to the circumferences or diameters of the two wheels.

This will become sufficiently clear, if it be considered as a compound lever, which was explained above. Instead of a combination of two wheels, three or four wheels may work in each other, or any number; and by thus increasing the number of wheels, or by proportioning the wheels to the axes, any degree of power may be acquired.

To this sort of engine belong all cranes for raising great weights; and in this case, the wheel may have cogs all round it instead of handles; and a small lanthorn, or trundle, may be made to work in the cogs, and be turned by a winch; which will make the power of the engine to exceed the power of the man who works it, as much as the number of revolutions of the winch exceeds those of the axle *CD* (Plate 2. fig. 1). when multiplied by the excess of the length of the winch above the length of the semi-diameter of the axle, added to the semi-diameter or half-thickness of the rope *K* by which the weight is drawn up. Thus, suppose the diameter of the rope and axis taken together to be 13 inches, and consequently half their diameter to be  $6\frac{1}{2}$  inches, so that the weight *W* will hang at  $6\frac{1}{2}$  inches perpendicular distance from below the centre of the axle: now, let us suppose the wheel *AB*, which is fixed on the axle, to have 80 cogs, and to be turned by means of a winch  $6\frac{1}{2}$  inches long, fixed on the axle of a trundle of eight staves, or rounds, working in the

cogs of the wheel ; here it is plain, that the winch and trundle would make ten revolutions for one of the wheel A B and its axis C D on which the rope K winds in raising the weight W ; and the winch being no longer than the sum of the semi-diameters of the great axle and rope, the trundle could have no more power on the wheel than a man could have by pulling it round by the edge, because the winch would have no greater velocity than the edge of the wheel has, which we here suppose to be ten times as great as the velocity of the rising weight ; so that, in this case, the power gained would be as is 10 to 1. But if the length of the winch be 13 inches, the power gained will be as 20 to 1 ; if  $19\frac{1}{2}$  inches (which is long enough for any man to work by), the power gained will be as 30 to 1 ; that is, a man could raise 30 times as much by such an engine, as he could do by his natural strength without it, because the velocity of the handle of the winch would be 30 times as great as the velocity of the rising weight ; the absolute force of any engine being in proportion of the velocity of the power, to the velocity of the weight raised by it. But then, just as much power or advantage as is gained by the engine, so much time is lost in working it ; which is common in all mechanical cases whatever.

In this sort of machines, it is requisite to have a *ratchet* wheel on the end of the axle C, with a *catch* to fall into its teeth ; which will at any time support the weight, and keep it from descending, if the person who turns the handle should, through inadvertency or carelessness, quit his hold while the weight is raising. By this means, the danger is prevented which might otherwise happen by the running down of the weight when left at liberty.

## THE PULLEY.

The pulley is a small wheel turning on an axis, with a drawing rope passing over it: the small wheel is usually called a *sheeve*, and is so fixed in a *box*, or *block*, as to be moveable round a pin passing through its centre.

Pulleys are of two kinds. 1. *Fixed*, which do not move out of their places. 2. *Moveable*, which rise and fall with the weight.

When a pulley is fixed, as Plate 2. fig. 5. two equal weights, suspended to the ends of a rope passing over it, will balance each other; for they stretch the rope equally; and if either of them be pulled down through any given space, the other will rise through an equal space in the same time; and consequently, as the velocities of both are equal, they must balance each other. This kind of pulley, therefore, gives no mechanical advantage; so that you can raise no greater weight by it than you could do by your natural strength. Its use consists in changing the direction of the power, and sometimes enabling it to be applied with more convenience. By it, a man may raise a weight to any point, without moving from the place he is in; whereas, otherwise, he would have been obliged to ascend with the weight: it also enables several men together to apply their strength to the weight by means of the rope.

The moveable pulley represented at A, (Plate 2. fig. 6.) is fixed to the weight W, and rises and falls with it. In comparing this to a lever, the fulcrum must be considered as at A (Fig. 6.); the weight acts upon the centre c, and the power is applied at the extremity of the lever D. The power,

therefore, being twice as far from the fulcrum as the weight is, the proportion between the power and weight, in order to balance each other, must be as 1 to 2. Whence it appears, that the use of this pulley doubles the power; and that a man may raise twice as much by it as by his strength alone. Or it may be considered in this way; every moveable pulley hangs by two ropes equally stretched, and which must, consequently, bear equal parts of the weight; but the rope A B being made fast at B, half the weight is sustained by it; and the other part of the rope, to which the power is applied, has but half the weight to support; consequently, the advantage gained by this pulley is as 2 to 1.

When the upper and fixed block contains two pulleys which only turn upon their axis, and the lower moveable block contains also two, which not only turn on their axis, but rise with the weight F (Fig. 7.) the advantage gained is as 4 to 1; for each lower pulley will be acted upon by an equal part of the weight; and, because in each pulley that moves with the weight, a double increase of power is gained, the force by which F may be sustained will be equal to half the weight divided by the number of lower pulleys; that is, as twice the number of lower pulleys is to 1, so is the weight suspended to the power.

But if the extremity C (Fig. 8.) be fixed to the lower block, it will sustain half as much as a pulley: consequently here the rule will be, as twice the number of pulleys adding unity is to 1, so is the weight to the power.

These rules hold good, whatever may be the number of pulleys in the blocks.

If, instead of one rope going round all the pulleys, the rope belonging to each pulley be made fast at



top, as in fig. 9, a different proportion between the power and the weight will take place. Here it is evident, that each pulley doubles the power; thus, if there are two pulleys, the power will sustain four times the weight; if three pulleys, eight times the weight; if four pulleys, sixteen times; and so on.

When pulleys in blocks are placed perpendicularly under each other, on separate pins, they occupy considerable space, and would not in general answer; it is, therefore, common to place all the pulleys in each block on the same pin, by the side of each other, as in fig. 10; but the advantage and rule for the power are the same here as in fig. 7 and 8.

A pair of blocks with the rope fastened round it, is commonly called a *tackle*.

#### THE INCLINED PLANE.

This mechanic power is of very great use in rolling up heavy bodies, such as casks, wheelbarrows, &c. It is formed by placing boards, earth, or other materials in a sloping direction.

The force wherewith a body descends upon an inclined plane is to the force of its absolute gravity, by which it would descend perpendicularly in free space, as the height of the plane is to its length. For suppose the plane A B (Plate S. fig. 1.) to be parallel to the horizon, the cylinder C will keep at rest on any part of the plane where it is laid. If the plane be placed perpendicularly, as A B, fig. 2, the cylinder C will descend with its whole force of gravity, because the plane contributes nothing to its support or hindrance; and therefore it would require a power equal to its whole weight to keep it from descending.

Let  $A B$  (Fig. 3.) be a plane parallel to the horizon, and  $A D$  a plane inclined to it; and suppose the whole length  $A D$  to be three times as great as the perpendicular  $D B$ . In this case, the cylinder  $E$  will be supported upon the plane  $D A$ , and kept from rolling, by a power equal to a third part of the weight of the cylinder; therefore a weight may be rolled up in this inclined plane by a third part of the power which would be sufficient to draw it up by the side of an upright wall.

It must also be evident, that the less the angle of elevation, or the gentler the ascent is, the greater will be the weight which a given power can draw up; for the steeper the inclined plane is, the less does it support of the weight; and the greater the tendency which the weight has to roll, consequently the more difficult for the power to support it: the advantage gained by this mechanical power, therefore, is as great as its length exceeds its perpendicular height.

To the inclined plane may be reduced all hatchets, chisels, and other edge-tools.

#### THE WEDGE.

The wedge may be considered as two equally inclined planes, joined together at their bases; then  $D C$  (Plate 3. fig. 4.) is the whole thickness of the wedge at its back  $A B C D$ , where the power is applied;  $E F$  is the depth or height of the wedge;  $B F$  the length of one of its sides; and  $O F$  is its sharp edge, which is entered into the wood intended to be split by the force of a hammer or mallet striking perpendicularly on its back. Thus,  $A B$  (Fig. 5.) is a wedge driven into the cleft  $C E D$  of the wood  $F G$ .

When the wood does not cleave at any distance before the wedge, there will be an equilibrium be-

tween the power impelling the wedge downward and the resistance of the wood acting against the two sides of the wedge, when the power is to the resistance, as half the thickness of the wedge at its back is to the length of either of its sides; because the resistance then acts perpendicular to the sides of the wedge. But when the resistance on each side acts parallel to the back, the power that balances the resistances on both sides will be, as the length of the whole back of the wedge is to double its perpendicular height.

When the wood cleaves at any distance before the wedge (as it generally does) the power impelling the wedge will not be to the resistance of the wood as the length on the back of the wedge is to the length of both its sides, but as half the length of the back is to the length of either side of the cleft estimated from the top or acting part of the wedge. For, if we suppose the wedge to be lengthened down from the top C. E to the bottom of the cleft at D, the same proportion will hold; namely, that the power will be to the resistance, as half the length of the back of the wedge is to the length of either of its sides: or, which amounts to the same thing, as the whole length of the back is to the length of both the sides.

The wedge is a mechanic power of great effect, since not only wood, but even rocks, can be split by it; which it would be impossible to accomplish by the lever, wheel and axle, or pulley; for the force of the blow or stroke shakes the cohering parts, and thereby makes them separate more easily.

#### THE SCREW.

The screw can scarcely be called a simple machine, because it is never used without the appli-

cation of a lever or winch to assist in turning it; and then it becomes a compound engine of a very great force, either in pressing the parts of bodies closer together, or in raising great weights. It may be conceived to be made by cutting a piece of paper, A B C (Plate 3. fig. 6.) into the form of an inclined plane or half wedge, and then wrapping it round a cylinder (Fig. 7.) the edge of the paper A C will form a spiral line round the cylinder, which will give the thread of the screw. It being evident, that the winch must turn the cylinder once round, before the weight of resistance can be moved from one spiral winding to another, as from *d* to *c*; therefore, as much as the circumference of a circle described by the handle of the winch is greater than the interval or distance between the spirals, so much is the force of the screw. Thus, supposing the distance of the spirals to be half an inch, and the length of the winch 152 inches, the circle described by the handle of the winch where the power acts will be 76 inches nearly, or about 152 half inches; and consequently 152 times as great as the distance between the spirals: and therefore a power at the handle, whose intensity is equal to no more than a single pound, will balance 152 pounds acting against the screw; and as much additional force as is sufficient to overcome the friction will raise the 152 pounds; and the velocity of the power will be to the velocity of the weight, as 152 to 1. Hence it appears, that the longer the winch is, and the nearer the spirals are to one another, so much the greater is the force of the screw.

A machine for showing the force or power of the screw may be contrived in the following manner. Let the wheel C have a screw (Fig. 8.) on its axis,

working in the teeth of the wheel D, which suppose to be 48 in number. It is plain, that for every time the wheel C and the screw are turned round by the winch A, the wheel D will be moved one tooth by the screw; and therefore, in 48 revolutions of the winch, the wheel D will be turned once round. Then, if the circumference of a circle, described by the handle of the winch A, be equal to the circumference of a groove round the wheel D, the velocity of the handle will be 48 times as great as the velocity of any given point in the groove. Consequently, if a line G goes round the groove, and has a weight of 48 pounds hung to it, a power equal to one pound at the handle will balance and support the weight. To prove this by experiment, let the circumferences of the grooves of the wheels C and D be equal to one another; and then if a weight H, of one pound, be suspended by a line going round the groove of the wheel C, it will balance a weight of 48 pounds hanging by the line G; and a small addition to the weight H will cause it to descend, and so raise up the other weight.

If a line G, instead of going round the groove of the wheel D, goes round its axle I, the power of the machine will be as much increased as the circumference of the groove exceeds the circumference of the axis: supposing it to be six times, then one pound at H will balance six times 48, or 288 pounds, hung to the line on the axis: and hence the power or advantage of this machine will be as 288 to 1. That is to say, a man, who by his natural strength could lift a hundred weight, will be able to raise 288 cwts. by this engine. If a system of pulleys were applied to the cord H, the power would be increased to an amazing degree.

When a screw acts in a wheel in this manner, it is called an *endless screw*.

When the screw is not employed in turning a wheel, it consists of two parts: the first is called the *male*, or outside screw, being cut in such a manner as to have a prominent part going round the cylinder in a spiral manner, which prominent part is called the *thread* of the screw: the other part, which is called the *female*, or inside screw, is a solid body, containing a hollow cylinder, whose concave surface is cut in the same manner as the convex surface of the male screw, so that the prominent parts of the one may fit the concave parts of the other.

A very considerable degree of friction always acts against the power in a screw; but this is fully compensated by other advantages: for on this account the screw continues to sustain a weight, even after the power is removed, or ceases to act, and presses upon the body against which it is driven. Hence the screw will sustain very great weights; insomuch, that several screws, properly applied, would support a large building, whilst the foundation was mending, or renewed.

#### OF COMPOUND MACHINES.

Although it be evident from the principles delivered above, that any one of the mechanic powers is capable of overcoming the greatest possible resistance, in theory: yet, in practice, if used singly, for producing very great effects, they would be frequently so unwieldy and unmanageable, as to render it impossible to apply them. For this reason, it is generally found more advantageous to combine them together; by which means the power

is more easily applied, and many other advantages obtained. In all machines, simple as well as compound, *what is gained in power is lost in time*. Suppose that a man, by a fixed pulley, raise a beam to the top of a house in two minutes, it is clear that he will be able to raise six beams in twelve minutes; but by means of a tackle, with three lower pulleys, he will raise the six beams at once with the same ease as he before raised one; but then he will be six times as long about it, that is, twelve minutes: thus the work is performed in the same time whether the mechanical power be used or not. But the convenience gained by the power is very great; for if the six beams be joined in one, they may be raised by the tackle, though it would be impossible to move them by the unassisted strength of one man.

Consequently, if by any power you are able to raise a pound with a given velocity, it will be impossible, by the help of any machine, to raise two pounds with the same velocity; yet, by the assistance of a machine, you may raise two pounds with half that velocity, or even one thousand with the thousandth part of that velocity; but still there is no greater quantity of motion produced, when a thousand pounds are moved, than when one pound is moved; the thousand pounds moving proportionally slower.

No real gain of force is, therefore, obtained by mechanical contrivances: on the contrary, from friction, and other causes, force is always lost; but by machines we are able to give a more convenient direction to the moving power, and to apply its action at some distance from the body to be moved, which is a circumstance of infinite importance. By machines, also, we can so modify the energy of the

moving power, as to obtain effects which it could not produce without this modification.

In machines composed of several of the mechanic powers, the power will be to the weight, when they are in equilibrio, in a proportion formed by the multiplication of the several proportions which the power bears to the weight in every separate mechanic power of which the machine consists.

Suppose a machine, for instance, composed of the axis in the wheel, and a pulley; let the axis and wheel be such, that a power consisting of one-sixth of the weight will balance it; and let the pulleys be such, that by means of them alone, a power equal to one-fourth of the weight would support it: then, by means of the axis in the wheel, and the pulleys combined, a power equal to one-fourth of one-sixth, that is,  $\frac{1}{24}$ th of the weight, will be in equilibrio with it.

In contriving machines, simplicity ought particularly to be attended to; for a complicated machine is not only more expensive, and more apt to be out of order, but there is also a greater degree of friction in proportion to the number of rubbing parts.

Whatever be the construction of a machine, its power will always be in proportion to the velocity of the power to the weight; and so that this is obtained in the greatest degree that circumstances will admit, or that are necessary, then the fewer parts the better.

It is evident, from what has been said above, that the velocity of a wheel is to that of a pinion, or smaller wheel which is driven by it, in proportion to the diameter, circumference, or number of teeth in the pinion to that of the wheel. Thus, if the number of teeth in a wheel be 60, and those



of the pinion 5, then the pinion will go 12 times round for once of the wheel, because 60, divided by 5, gives 12 for a quotient.

Hence, if you have any number of wheels acting on so many pinions, you must divide the product of the teeth in the wheels by those in the pinions; and the quotient will give the number of turns of the last pinion in one turn of the first wheel. Thus, if a wheel A (Plate 3. fig. 9. of 48, acts on a pinion B of 8, on whose axis there is a wheel C of 40, driving a pinion D of 6, carrying a wheel E of 36, which moves a pinion F of 6, carrying an index: then the number of turns made by the index, will be found in this manner:  $\frac{48}{8} \times \frac{40}{6} \times \frac{36}{6} = \frac{120}{1} \times \frac{36}{6} = 240$ , the number of turns which the index will make while the wheel A goes once round.

Any number of teeth on the wheels and pinions having the same ratio, will give the same number of revolutions to an axis: thus,  $\frac{64}{8} \times \frac{50}{5} \times \frac{36}{6} = \frac{1280}{1} = 240$ , as before. It therefore depends upon the skill of the engineer, or mechanic, to determine what numbers will best suit his design.

It is evident, that the same motion may be performed, either by one wheel and pinion, or by many wheels and pinions, provided the number of turns of all the wheels bear the same proportion to all the pinions which that one wheel bears to its pinion.

When a wheel is moved immediately by the power, it is called a *leader*; and if there is another wheel on the same axis, it is called the *follower*. Thus A, being moved immediately by the power, is to be considered as a leader, and B as a follower; the wheel C being driven by B becomes a leader, and D a follower; E (Fig. 10.) is a leader, and the cylinder F may be considered as a follower.

Sometimes the same wheel acts both as a leader and a follower; as in Fig. 11, where B is moved by A, and consequently is a leader; while, as it drives C, it is also a follower. Therefore, as to multiply both the divisors and dividend by the same number does not alter the quotient, so in mechanical calculations, every wheel that is both a leader and a follower may be entirely omitted.

The power of a machine is not at all altered by the size of the wheels, provided the proportions to each other are the same. Formerly the wheels of engines being mostly of wood, they were made of a large size, on account of strength; but now that wheels are so easily made of cast iron, the size of them is very much diminished, which has the advantage of occupying much less room, with greater durability.

#### MOVING POWERS IN MACHINERY.

The motion of machines must be excited and kept up by some cause which is called the *moving power*.

These powers may be, the strength of men and other animals; or inanimate, as wind, water, steam, gravity, or elasticity.

In working machines, the choice of the moving power must be regulated by convenience and economical considerations, and also by the regularity and intensity of its action.

Weights and running water are most uniform in their action, and steam is that which is capable of the greatest intensity. The strength of animals is the most unequal.

A horse draws with the greatest advantage, when the line of draught is not level with his breast; but

inclines upwards, making a small angle with the horizontal plane.

A horse drawing a weight over a single pulley, can draw 200 lbs. for eight hours a day, and walking at the rate of  $2\frac{1}{2}$  miles in an hour, which is about  $3\frac{1}{2}$  feet in a second; and if the same horse be made to draw 240 lbs., he can work but six hours a day, and cannot go quite so fast. To this may be referred the working of horses in all sorts of mills and water-works, where we ought to know, as near as we can, how much we make every horse draw, that we may judge of what the effect will be when proper allowance shall have been made for all the frictions and hindrances, before we cause any machine to be erected.

When a horse draws in a mill, or gin of any kind, great care should be taken that the horse-walk, or circle in which he moves, be large enough in diameter, otherwise the horse cannot exert all his strength; for, in a small circle, the tangent in which the horse draws deviates more from the circle in which he is obliged to go, than in a larger circle. The horse-walk should not be less than 40 feet in diameter, when there is room for it. In a walk of 19 diameter, it has been calculated that a horse loses two-fifths of his strength.

The worst way of applying the force of a horse is to make him carry or draw up hill; for, if the hill be steep, three men will do more than a horse; each man loaded with 100 lbs. will move up faster than a horse that is loaded with 300 lbs. This is owing to the position of the parts of a man's body, which are better adapted for climbing than those of a horse.

As a horse, from the structure of his body, can exert most strength in drawing almost horizontally

in a straight line, a man exerts the least strength that way; as, for example, if a man weighing 140 lbs., walking by a river or canal side, draws along a boat, or barge, by means of a rope coming over his shoulders, or otherwise fastened to his body, he cannot draw above 27 lbs., or about 1-27th of what a horse can draw in that case. Five men are about equal in strength to one horse, and can with the same ease push round the horizontal beam in a 40 foot walk; but three of the same men will push round a beam in a 19 foot walk, which a horse, (otherwise equal to five men) can but draw round.

A man turning a horizontal windlass by a handle, or winch, should not have above 30 lbs. weight acting against him, if he is to work ten hours a day, and raise the weight at the rate of three feet and a half in a second. This supposes, however, that the semi-diameter of the windlass is equal to the distance from the centre to the elbow of the handle; for if there be a mechanical advantage, as there usually is, by having the diameter of the axle on which the rope winds four or five times less than the diameter of the circle described by the hand, then may the weight (taking in also the resistance, on account of the friction and stiffness of the rope) be four or five times greater than 30 lbs.; that is, so much as it rises slower than the hand moves.

In this operation, the effect of a man's force varies in every part of the circle described by the handle. The greatest force is, when a man pulls the handle upwards from about the height of his knees; and the least force when (the handle being at top) he thrusts from him horizontally; then again the effect becomes greater, as a man lays on his weight to push down the handle; but that

action cannot be so great as when he pulls up, because he lays on no more than the whole weight of his body; whereas, in pulling, he can exert his whole strength. Lastly, he has but small force to pull the handle towards him horizontally, when at its lowest.

Let us suppose a man of moderate strength to weigh 140 lbs.; he may in the four principal parts of pushing and pulling, in the whole circumference of motion, exert the following forces; viz. in the strongest point, a force equal to 160 lbs.; in the weakest, a force equal to 27 lbs.; in the next strong point, 130 lbs.; and in the last, or second weak point, 30 lbs. Let us add all these forces together, which will make 347; which divide by 4, and we shall have 84 $\frac{3}{4}$  lbs. for the weight that a man might lift by a winch, if he could exert his whole force continually, without stopping to take breath; but as that cannot be, the weight must return, and overpower at the first weak point, especially when the handle moves slowly, as it must, if a man would exert his whole strength all round. Besides, for raising such a weight, we must suppose the man acting always along the tangent of the circle of motion, which does not happen in the operation. Then there must be a sufficient velocity given, that the force applied at the strong points may not be spent before the hand comes to the weak ones, so that it is difficult for a man to continue that irregular motion; and, therefore, when there are no other advantages, the resistance ought to be but 30 lbs. If a fly be added to the windlass when the motion is pretty quick, as about four or five feet in a second, a man may for a little while act with a force of 80 lbs. and work a whole day with a resistance of 10 lbs.

If two men work at the end of a roller, or windlass, as in drawing up coals or ore from a mine, or water from a well, they may more easily draw up 70 lbs. (still supposing the weight and power to have equal velocities) than one man can 30 lbs., provided the elbow of one of the handles be at right angles to the other; for then one man will act at the strongest point when the other acts at the weakest point of the revolution; by which means the two men will mutually and successively help one another. A very common way is to put on the handles opposite to one another, which cannot give the advantage above-mentioned, though there is some little force gained even in that position, because one man pulling while the other thrusts, works at the strongest of the two weak points, whilst the other works at the weakest, and so helps him a little.

When a man carries a burden upon his back, he exerts a great force very effectually, many muscles being at once employed in that operation; the muscles of his neck, back, and loins, keep his body and head in the proper position to sustain the weight; those of his shoulders and arms help to keep it in its place; and the muscles of his legs and thighs raise the weight of all the body and burden as the man walks along. In this way of working, three men do much more than a horse, and two often do as much, as may be observed in the daily labour of the London porters. A porter will carry 200 lbs. and walk at the rate of three miles an hour; a coal-heaver will carry 250 lbs.; but then he does not go far with his load. Chairmen do not act with the same muscles as porters; but as they have straps brought down from their shoulders to the poles of the chair, the muscles of

the loins and back are concerned, and likewise the extensors of the legs and thighs ; two of them will walk with 300 lbs. (that is, 150 lbs. each,) at the rate of four miles an hour.

The last and most effectual way of a man's exerting his strength, is in rowing a boat ; he there acts with more muscles than in any other operation ; and the weight of his body also assists him.

## FRICTION.

By friction is meant the rubbing of bodies against each other. The subject of friction is of great importance in mechanics, as, in consequence of it, the actual performance of machines is much less than what might be expected from calculation.

However smooth bodies may appear to the eye, yet if they are examined with a microscope, numerous inequalities will be observed, and when surfaces move over each other, the prominences of one fall into the hollows of another, and some force must be required to lift or drag one over the other, or its prominences must be broken off.

Friction is greater in moving bodies in proportion to their weight or pressure against each other : and also in some degree in proportion to the velocity of their motion.

Polished substances, as might be expected, have less friction than rough ones ; and oil, grease, and black lead, by filling up the inequalities of the surfaces of bodies, lessen the friction.

Metals have more friction when moving on metals of the same kind, than when they move on different metals. Thus, steel and brass are frequently employed together to lessen the friction :

this may be seen in clocks and watches, where the wheels are of brass, and the pinions of steel.

Hard substances, also, being less subject to wear, are employed to diminish friction; thus jewels are used in watches for the axles of the wheels to work in.

Hard wood rubbing against hard wood has less friction than when rubbing against soft wood.

The wearing of the parts of a machine, by altering the shapes of the parts, and increasing the inequalities, occasions more friction.

The friction of a single lever is very little.

The friction of the wheel and axle is in proportion to the weight, velocity, and the diameter of the axle; the smaller the diameter of the axle, the less will be the friction.

The friction of pulleys is very great, on account of the smallness of their diameters in proportion to that of their axes; because they very often bear against the blocks, and through the wearing of their wheels and axles.

In the wedge and screw, there is a great deal of friction. Screws with sharp threads have more friction than those with square threads; and endless screws have more than either.

The most complete method of lessening the friction of wheels is to make their axles turn on the surfaces of smaller wheels, which hence are called *friction wheels*.

#### OF THE COMMUNICATION OF MOTION IN MACHINES.

Numerous are the methods by which motion may be communicated from one part of a machine



to another; and much of the skill of the engineer consists in his adapting certain methods to his particular purposes.

Sometimes a simple cord, or a cord with pulleys, may be used. Levers, either simple or combined, and either straight or bent, are employed to communicate, and also change the direction of the motion. Rods also are employed, which may be carried to a great distance by being connected together.

But of all the methods of communicating motion, that by means of wheels is the most frequent.

Wheels may be made to turn each other even by the simple contact of their surfaces when pressed together; or their circumferences may be formed into brushes with short thick hair, which enable them to turn each other with considerable power; or they may have cords or straps of leather or chains, passing from one to another, and then sometimes there are points or protuberances on the rims of the wheels.

The most usual method, however, of making wheels drive each other is by means of teeth. These are either cut into the substance of which the wheel is formed when it is metal; or formed at the same time as the rest of the wheel when this is cast metal; or formed by inserting them when the wheels are of wood.

The proper method of shaping the teeth of wheels, so as to communicate the motion equably, and with as little friction as possible, is a matter of very great nicety, and has given rise to much study among mechanics. The ends of the teeth should be curves, but not parts of circles. They may be formed of the curve called the epicycloid; or of the involutes of circles, which are curves de-

scribed by a point of a thread which has been wound round the wheel while it is uncoiled.

A wheel which has teeth cut upon the circumferences so as to project out in the plane of its face, is called a spur wheel, (Plate 25. fig. 1.); and when the projection of the teeth is at right angles to the face of the wheel and parallel to the axis, the wheel is called a crown, or contrate wheel, as at B: C is a spur wheel.

Sometimes the faces of the two wheels are in the same plane, and consequently the axes parallel as at fig. 1; sometimes the axes are at right angles to each other, as fig. 2., one being a spur and the other a contrate wheel: sometimes also the axes are inclined to each other at various angles.

A method much used for placing the teeth of wheels, is by bevelling the edge, and cutting the teeth on the bevel, by which means wheels can turn each, though variously inclined, and the teeth have also great strength. These are called *bevelled wheels*, or *bevel geer*.

Their principle consists in two cones rolling on the surface of each other, as the cone A and B revolving on their centres  $a b$ ,  $a c$  (Plate 4. fig. 4); if their bases are equal, they will perform their revolutions in one and the same time; or any other two points equally distant from the centre  $a$ , as  $d 1$ ,  $d 2$ ,  $d 3$ , &c. will revolve in the same time as  $f 1$ ,  $f 2$ ,  $f 3$ , &c. In the like manner, if the cones  $a d e$  be twice the diameters at the base  $d e$ , as the cones  $a f e$  are, then if they turn about their centres when the cone  $a f d$  (Fig. 5. and 6.) has made one revolution, the cone  $a d e$  will have made but half a revolution; or when  $a f e$  has made two revolutions,  $a d e$  will have made but one, and every part equally distant from the centre

$a$ , as  $f$  1,  $f$  2,  $f$  3, &c. will have made two revolutions to  $e$  1,  $e$  2,  $e$  3, &c. and if the cones were fluted, or had teeth cut in them, diverging from the centre  $a$  to the bases  $d$   $c$ ,  $e$   $f$  (Fig. 7), they would then become bevel-geer. The teeth at the point of the cone being small, and of little use, may be cut off at  $E$  and  $F$  (Fig. 7. and 8.) where the upright shaft  $a$   $b$ , with the bevel-wheel  $c$   $d$ , turns the bevel-wheel  $e$   $f$  with its shaft  $b$   $g$ , and the teeth work freely into each other. The teeth may be made of any dimension, according to the strength required; and this method will enable them to overcome a much greater resistance, and work smoother than a face-wheel and wallower of the common form can possibly do; besides, it is of great use to convey a motion in any direction, or to any part of a building, with the least trouble and friction.

The method of conveying motion in any direction, and proportioning or shaping the wheels thereto, is as follows: Let the line  $a$   $b$  fig. 9. represent a shaft coming from a wheel; draw the line  $c$   $d$  to intersect the line  $a$   $b$  in the direction that the motion to be conveyed is intended, which will now represent a shaft to the intended motion.

Again, suppose the shaft  $c$   $d$  is to revolve three times, whilst the shaft  $a$   $b$  revolves once; draw the parallel line  $i$   $i$ , at any distance not too great (suppose one foot by a scale,) then draw the parallel line  $k$   $k$  at three feet distance; after which, draw the dotted line  $w$   $x$  through the intersection of the shafts  $a$   $b$  and  $c$   $d$ , and likewise through the intersection of the parallel lines  $i$   $i$  and  $k$   $k$ , in the points  $x$  and  $y$ , which will be the pitch-line of the two bevel-wheels, or the line where the teeth of

the two wheels act on each other, as may be seen fig. 10., where the motion may be conveyed in any direction.

Hook's universal joint, as represented Plate 4. fig. 11., may be applied to communicate motion instead of bevel-geer, where the speed is to be continued the same, and where the angle does not exceed 30 or 40 degrees, and the equality of motion is not regarded; for as it recedes from a right line, its motion becomes more irregular. This joint may be constructed by a cross, as represented in the figure; or with four pins fastened at right angles upon the circumference of a hoop, or solid ball. It is of great use in cotton mills, where the tumbling shafts are continued to a great distance from the moving power. But by applying this joint, the shafts may be cut into convenient lengths, by which it will be enabled to overcome greater resistance.

#### REGULATION OF MOTION BY FLY WHEELS.

In all machines, the moving power acts with more or less irregularity, being sometimes stronger, and at other times weaker.

To correct this, and render the motion uniform, an additional part, called a *fly*, is sometimes applied, which is generally either a heavy wheel, or a cross bar loaded with equal weights. This, being made to revolve about its axis, keeps up the force of the power, and distributes it equally in all parts of its revolution; for, on account of its weight, a small variation in force does not sensibly alter its motion; whilst friction, and the resistance of the machine, prevent it from accelerating. If

the motion of the machine slackens, it helps it forward: if it tends to move too fast, it will keep it back.

Every regulating-wheel should be fixed upon that axis where the motion is swiftest, and should be heavy when the motion is designed to be slow, and light where it is designed to be swift. In all cases, the centre of motion should coincide with the centre of gravity of the wheel. The axis may be either perpendicular, or parallel to the horizon.

A small force is sufficient to put a heavy wheel in motion, which, if long continued, will accumulate in such a manner, as to produce effects in raising weights and overcoming resistances, that could not by any means be accomplished by the application of the original moving force.

On this subject, Mr. Atwood has demonstrated, that a force of 20 pounds applied for 37 seconds to the circumference of a cylinder of a 10 feet radius, and weighing 4713 pounds, would, at the distance of one foot from the centre, give an impulse to a musket ball equivalent to what it receives from a full charge of gunpowder. The same effect would be produced in six minutes and ten seconds by a man turning the cylinder with a winch one foot long, in which he constantly exerted a force of 20 pounds. In this case, however, there is no absolute increase of power; for the cylinder has no principle of motion in itself, and cannot have more than it receives.

This accumulation of motion, however, in heavy wheels, is of great service in the construction of machines for various purposes, rendering them much more powerful, and easy to be worked by animals, as well as more regular and steady, when set in motion by water, or any inanimate power.

Hence the use of flies, ballast-wheels, &c. which are commonly supposed to increase the power of a machine, though in reality they take something from it, and act upon a different principle.

In all machines in which flies are used, a considerably greater force must at first be applied than what is necessary to move the machine without it, or the fly must have been set in motion some time before it is applied to the machine. This superfluous power is collected by the fly, which serves as a kind of reservoir from whence the machine may be supplied when the motion slackens.

This, we must observe, will always be the case with machines worked by animals, for none are able to exert a great power with absolute constancy: some intervals of rest, even though almost imperceptible, are requisite, otherwise the creature's strength would in a short time be exhausted. When he begins to move in a machine, he is vigorous, and exerts a great power; in consequence of which he overcomes not only the resistance of the machine itself, but communicates a considerable degree of power to the fly. The machine, when moving, yields for a time to a smaller impulse; during which time the fly itself acts as a moving power, and the animal recovers the strength he has lost. By degrees, however, the motion of the machine decreases, and the animal is obliged to renew his efforts. The velocity of the machine would now be considerably increased, were it not that the fly now acts as a resisting power, and the greatest part of the superfluous motion is lodged in it, so that the increase of velocity is scarcely perceptible. Thus the animal has time to rest himself, until the machine again requires an increased impulse, and so on alternately.

The case is the same with a machine moved by water, or by a weight ; for though the strength of these does not exhaust itself like that of an animal, yet the yielding of the parts of the machine renders the impulse much less after it begins to move ; hence its velocity is accelerated for some time, until the impulse becomes so small, that the machine requires an increase of power to keep up the necessary motion. Then the machine slackens its pace, the water meets with more resistance, and of consequence exerts its power more fully, and the machine recovers its velocity.

But when a fly is added to the other parts, this acts first as a power of resistance, so that the machine does not acquire the velocity it would otherwise do. When it next begins to yield to the pressure of the water, and the impulse of course to slacken, the fly communicates part of its motion to the other parts ; so that if the machine be well made, there is very little difference in the velocity perceptible.

The truth of what is here advanced will easily be seen, from considering the inequality of motion in a clock, when the pendulum is off, and how very regularly it goes when regulated by a pendulum, which here acts as a fly.

Flies are particularly useful in any kind of work which is done by alternate strokes, as the lifting of large pestles, pumping of water, &c. In this case, the weight of the wheel employed is a principal object ; and the method of calculating this is to compare it with the weight to be raised at each stroke of the machine. Thus, suppose it is required to raise a pestle 30 pounds weight to the height of one foot, 60 times in a minute ; let the diameter of the fly be seven feet, and suppose the

pestle to be lifted once at every revolution of the fly; we must then consider what weight, passing through 22 feet in a second, will be equivalent to 30 pounds moving through one foot in a second. This will be 30 divided by 22, or  $1\frac{4}{11}$  pounds. Were a fly of this kind to be applied, therefore, and the machine set a-going, the fly would just be able to lift the pestle once, after the moving power was withdrawn: but by increasing the weight of the fly to 10, 12, or 20 pounds, the machine, when left to itself, would make a considerable number of strokes, and be worked with much less labour than if no fly had been used, though, no doubt, at the first, it would be found a considerable incumbrance to the motion.

This is equally applicable to the action of pumps; but the weight which can be most advantageously given to a fly, has never yet been determined by mechanics. It is certain, however, that the fly does not communicate any absolute increase of power to the machine; for if a man, or other animal, is not able to set any engine in motion without a fly, he will not be able to do it though a fly be applied, nor will be able to keep it in motion, though set a-going with a fly, by means of a greater power.

This may seem to be contradicted by the example of a common clock; for if the pendulum be once stopped, the weight is not able to set it in motion again, though it will keep it going when once put in motion by an external power. This, however, depends not upon the insufficiency of the weight, but on the particular mechanism of the pallet-wheel, which is such, that when once the pendulum is stopped, it would require a much greater weight than that commonly applied to set



it in motion; and if the usual weight were to act fairly, it would be more than sufficient to move all the machinery, and make the pendulum vibrate also with much greater force than it does.

## OF MILLS.

A mill, in the strict sense of the word, signifies a machine for grinding corn, though the term *mill-work* is frequently applied to all kinds of machinery where large wheels are used.

Mills are distinguished into various kinds, either according to the powers by which they are moved, or the uses to which they are applied. Thus, there are *water-mills*, *horse-mills*, and *wind-mills*; *corn-mills*, *fulling-mills*, *powder-mills*, *boring-mills*, &c.

The limits of this work not permitting us to enter into the detail of all these different sorts of mills, we shall confine ourselves to that most useful machine, the *corn-mill*.

In ancient times, corn was ground only by hand-mills consisting of two stones similar to those used in water-mills, but much smaller, the upper one having a piece of wood fixed into it to move it by. They are still used in some parts of Scotland, and are called *querns*.

These, however, have given place to water-mills and wind-mills, which are now commonly used.

Water-mills are of three kinds:—*breast-mills*, *undershot-mills*, and *overshot-mills*, according to the manner in which the water is applied to the great wheel. In the first, the water falls down upon the wheel at right angles to the *float-boards*, or bucket, placed all round the wheel to receive it. In the second, which is used where there is no fall of

water, the stream strikes the float-boards at the lower part of the wheel. In the third, the water is poured over the top, and is received in buckets formed all round the wheel.

The following is a description of a corn-mill of the most common sort :

A B (Plate 3. fig. 12.) is the water wheel, which is generally from 18 to 24 feet in diameter, reckoned from the outermost edge of any float-board at A, to that of the opposite one at B. The water striking on the floats of this wheel, drives it round, and gives motion to the mill. The wheel is fixed upon a very strong axis, or shaft C, one end of which rests on D, and the other on E, within the mill-house.

On this shaft, or axis, and within the mill-house, is a wheel F, about eight or nine feet in diameter, having cogs all round, which work in the upright staves, or rounds, of a trundle G. This trundle is fixed upon a strong iron axis, called the spindle, the lower end of which turns in a brass foot fixed at H, in a horizontal beam H, called the bridge-tree ; and the upper end of the spindle turns in a wooden bush fixed into the nether mill-stone, which lies upon beams in the floor I. The top of the spindle above the bush is square, and goes into a square hole in a strong iron cross, *a b c d* (Fig. 13.), called the rynd ; under which, and close to the bush, is a round piece of thick leather upon the spindle, which it turns round at the same time as it does the rynd.

The rynd is let into grooves in the under surface of the running mill-stone K, and so turns it round in the same time that the trundle G is turned round by the cog-wheel F. This mill-stone has a large hole quite through its middle, called

the eye of the stone, through which the middle part of the rynd and upper end of the spindle may be seen ; whilst the four ends of the rynd lie below the stone in their grooves.

One end of the bridge-tree which supports the spindle rests upon the wall, whilst the other is let into a beam called the brayer, L M.

The brayer rests in a mortice at L ; and the other end M hangs by a strong iron rod N, which goes through the floor I, and has a screw-nut on its top at O ; by the turning of which nut, the end M of the brayer is raised or depressed at pleasure, and consequently the bridge-tree and the upper mill-stone. By this means, the upper mill-stone may be set as close to the under one, or raised as high from it, as the miller pleases.

The nearer the mill-stones are to each other, the finer the corn is ground ; and the more remote from one another, the coarser.

The upper mill-stone is inclosed in a round box, which does not touch it any where, and is about an inch distant from its edge all round. On the top of this box stands a frame for holding the hopper P, to which is hung the shoe Q, by two lines fastened to the hinder part of it fixed upon hooks in the hopper, and by one end of the string R fastened to the fore part of it ; the other end being twisted round the pin S. As the pin is turned one way, the string draws up the shoe closer to the hopper, and so lessens the aperture between them ; and as the pin is turned the other way, it lets down the shoe, and enlarges the aperture.

If the shoe be drawn up quite to the hopper, no corn can fall from the hopper into the mill : if it be let down a little, some will fall ; and the quan-

tity will be more or less, according as the shoe is more or less let down; for the hopper is open at bottom, and there is a hole in the bottom of the shoe, not directly under the bottom of the hopper, but nearer to the lowest end of the shoe, over the middle eye of the mill-stone.

There is a square hole in the top of the spindle, in which is put the feeder E (Fig. 13.); this feeder, as the spindle turns round, jogs the shoes three times in each revolution, and so causes the corn to run constantly down from the hopper through the shoe, into the eye of the mill-stone, where it falls upon the top of the rynd; and is, by the motion of the rynd, and the leather under it thrown below the upper stone, and ground between it and the lower one. The violent motion of the stone creates a centrifugal force in the corn going round with it; by which means it gets farther and farther from the centre, as in a spiral, in every revolution, until it be quite thrown out; and being then ground, it falls through a spout, called the mill-eye, into a trough placed to receive it.

When the mill is fed too fast, the corn bears up the stone, and is ground too coarse; and, besides, it clogs the mill, so as to make it go too slow. When the mill is too slowly fed, it goes too fast, and the stones, by their attrition, are apt to strike fire. Both which inconveniences are avoided by turning the pin S backward or forward, which draws up or lets down the shoe, and thus regulates the feeding, as the miller sees convenient.

The heavier the running mill-stone is, and the greater the quantity of water that falls upon the wheel, the faster will the mill bear to be fed; and consequently it will grind the more. And, on the contrary, the lighter the stone, and the less the

quantity of water, so much slower must the feeding be. But when the stone is considerably worn, and become light, the mill must be fed slowly at any rate; otherwise the stone will be too much borne up by the corn under it, which will make the meal coarse.

The quantity of power sufficient to turn a heavy mill-stone is but very little more than what is necessary to turn a light one; for, as it is supported upon the spindle by the bridge-tree, and the end of the spindle that turns in the brass foot therein being but small, the difference arising from the weight is but very inconsiderable in its action against the power or force of the water. And, besides, a heavy stone has the same advantage as a heavy fly: namely, that it regulates the motion much better than a light one.

The centrifugal force carrying the corn towards the circumference, it is natural that it should be crushed when it comes to a place where the interval between the two mill-stones is less than its thickness; yet the upper mill-stone being supported on a point which it can never quit, it does not so clearly appear why it should produce a greater effect when it is heavy than when it is light; since, if it were equally distant from the nether mill-stone, it could only be capable of a limited impression. But as experience proves that this is really the case, it is necessary to discover the cause. The spindle of the mill-stone being supported by a horizontal piece of timber, about nine or ten feet long, resting only on both its ends, by the elasticity of this piece, the upper mill-stone is allowed a vertical motion, playing up and down; by which movement, the heavier the stones are

the more forcibly is the corn wedged in between them.

In order to cut and grind the corn, both the upper and under mill-stones have channels or furrows cut into them, proceeding obliquely from the centre to the circumference. These furrows are cut perpendicularly on one side and obliquely on the other, which gives each furrow a sharp edge; and in the two stones they come, as it were, against one another, like the edges of a pair of scissors, and so cut the corn, to make it grind the easier, when it falls upon the places between the furrows. These are cut the same way in both stones, when they lie upon their backs, which makes them run crossways to each other when the upper stone is inverted by turning its furrowed surface towards that of the lower; for, if the furrows of both stones lay the same way, a great deal of the corn would be driven onward in the lower furrows, and so come out from between the stones, without being either cut or bruised.

The grinding surface of the under stone is a little convex from the edge to the centre, and that of the upper stone a little concave; so that they are farthest from one another in the middle, and approach gradually nearer towards the edges. By this means the corn, at its first entrance between the stones, is only bruised; but as it goes farther on towards the circumference or edge, it is cut smaller and smaller, and at last finely ground, just before it comes out from between them.

When the furrows become blunt and shallow by wearing, the running stone must be taken up, and both stones new drest with a chisel and hammer; and every time the stone is taken up, there must be some tallow put round the spindle upon the bush,

which will soon be melted by the heat the spindle acquires from its turning and rubbing against the bush, and so will get in betwixt them; otherwise the bush would take fire in a very little time.

The bush must embrace the spindle quite close, to prevent any shake in the motion, which would make some parts of the stones grate and fire against each other; whilst the other parts of them would be too far asunder, and by that means spoil the meal.

Whenever the spindle wears the bush, so as to begin to shake in it, the stone must be taken up, and a chisel driven into several parts of the bush; and when it is taken out, wooden wedges must be forced into the holes; by which means the bush will be made to embrace the spindle again, close all round. In doing this, great care must be taken to drive equal wedges into the bush on opposite sides of the spindle; otherwise it will be thrown out of the perpendicular, and so hinder the upper stone from being set parallel to the under one, which is absolutely necessary for making good work. When any accident of this kind happens, the perpendicular position of the spindle must be restored, by adjusting the bridge-tree with proper wedges put between it and the brayer.

It often happens, that the rynd is a little wrenched in laying down the upper stone upon it, or is made to sink a little lower on one side of the spindle than on the other; and this will cause one edge of the upper stone to drag all round upon the other, while the opposite edge will not touch. But this is easily set to rights, by raising the stone a little with the lever, and putting bits of paper, cards, or thin chips, between the rynd and the stone.

A less quantity of water will turn an overshot-mill (in which the wheel has buckets instead of float-boards) than a breast-mill, where the fall of water seldom exceeds half the height of the wheel; so that, when there is but a small quantity of water, and a fall great enough for the wheel to lie under it, the bucket, or overshot-wheel, is always used: but where there is a large body of water with a little fall, the breast or float-board wheel must be used. Where the water runs only upon a small declivity, it can act but slowly upon the under part of the wheel; in which case, the motion of the wheel will be slow; and therefore the floats ought to be very long, though not high, that a large body of water may act upon them; so that what is wanting in velocity may be made up in power; and then the cog-wheel may have a greater number of cogs, in proportion to the rounds in the trundle, in order to give the mill-stone a sufficient degree of velocity.

It was the opinion of SMEATON, that the powers necessary to produce the same effect on an under-shot-wheel, a breast-wheel, and an overshot-wheel, must be to each other as the numbers 2.4, 1.75, and 1.

*Practical Rules for the Construction of Mills.*

1. Measure the perpendicular height of the fall of water, in feet, above that part of the wheel on which the water begins to act, and call that the height of the fall.

2. Multiply this constant number 64.2882 by the height of the fall in feet, and the square root of the product will be the velocity of the water at



the bottom of the fall, or the number of feet that the water there moves per second.

3. Divide the velocity of the water by three, and the quotient will be the velocity of the float-boards of the wheel, or the number of feet they must each go through in a second, when the water acts upon them so as to have the greatest power to turn the mill.

4. Divide the circumference of the wheel in feet by the velocity of its floats in feet per second, and the quotient will be the number of seconds in which the wheel turns round.

5. By this last number of seconds divide 60, and the quotient will be the number of turns of the wheel in a minute.

6. Divide 120 (the number of revolutions a mill-stone four feet and a half diameter ought to have in a minute) by the number of turns of the wheel in a minute, and the quotient will be the number of turns the mill-stone ought to have for one turn of the wheel.

7. Then, as the number of turns of the wheel in a minute is to the number of turns of the mill-stone in a minute, so must the number of staves in the trundle be to the number of cogs in the wheel, in the nearest whole numbers that can be found.

By these rules, the following table is calculated to a water-wheel 18 feet diameter, which may be a good size in general.

*The Mill-Wright's Table.*

Height of the fall of water.	Velocity of the fall of water per second.		Revolutions of the wheel per minute.		Revolution of the mill-stone for one of the wheels.		Cogs in the wheel, and staves in the trundle.		Revolutions of the mill-stone per minute by these staves and cogs,			
	Feet.	Feet. 100 parts of a foot.	Feet.	100 parts of a foot.	Revolutions.	100 parts of a rev.	Revolutions.	100 parts of a rev.	Cogs.	Staves.	Revolutions.	100 parts of a rev.
1	8.02		2.67		2.83		42.40		254	6	119.84	
2	11.34		3.78		4.00		30.00		210	7	120.00	
3	13.89		4.63		4.91		24.44		196	8	120.28	
4	16.04		5.35		5.67		21.16		190	9	119.74	
5	17.93		5.98		6.34		18.92		170	9	119.68	
6	19.64		6.55		6.94		17.28		156	9	120.20	
7	21.21		7.07		7.50		16.00		144	9	120.00	
8	22.68		7.56		8.02		14.96		134	9	119.34	
9	24.05		8.02		8.51		14.10		140	10	119.14	
10	25.35		8.45		8.97		13.38		134	10	120.18	
11	26.59		8.86		9.40		12.76		128	10	120.32	
12	27.77		9.26		9.82		12.22		122	10	119.80	
13	28.91		9.64		10.22		11.74		118	10	120.36	
14	30.00		10.00		10.60		11.32		112	10	118.72	
15	31.05		10.35		10.99		10.98		110	10	120.96	
16	32.07		10.69		11.34		10.58		106	10	120.20	
17	33.06		11.02		11.70		10.26		102	10	119.34	
18	34.02		11.34		12.02		9.98		100	10	120.20	
19	34.95		11.65		12.37		9.70		98	10	121.22	
20	35.86		11.95		12.68		9.46		94	10	119.18	
1	2	3	4	5	6	7						

To construct a mill by this table, find the height of the fall of water in the first column, and against that height in the sixth column, you have the number of cogs in the wheel, and staves in the trundle, for causing the mill-stone, 4 feet 6 inches diameter, to make about 120 revolutions in a minute, as near as possible, when the wheel goes with one-third part of the velocity of the water. And it appears by the 7th column, that the number

of cogs in the wheel, and staves in the trundle, are so near the truth for the required purpose, that the least number of revolutions of the mill-stone in a minute is 118, and the greatest number never exceeds 121; which is according to the speed of some of the best mills.

It is of the greatest consequence to have the teeth of wheels so formed, that the pressure by which one of them urges the other round its axis, be constantly the same. This is by no means the case when the common construction of a spur-wheel, acting in the cylindrical staves of a lantern, or trundle, is used. The ends of teeth should never be formed of parts of circles, but of a particular curve, called the *epicycloid*, which is formed by moving the circle D (Fig. 13.) called the generating circle, round the circumference of another circle E, while it turns also round its own centre; then any point *o* will describe an epicycloid.

If a point *a* (Fig 12.) on the circumference of the circle B, proceed along the plane *a* C, in a right line, and at the same time revolve round its centre, it will describe a *cycloid*.

EMERSON observes, that the teeth of wheels ought not to act upon each other before they arrive at the line which joins their centres; and though the inner or under sides of the teeth may be of any form, yet it is better to make both sides alike, which will serve to make the wheels turn backwards. The more teeth that work together, the better; at least, one tooth should always begin before the other has done working. The teeth ought to be so disposed, as not to trouble or hinder one another before they begin to work.

If the cogs of a wheel and rounds of a trundle could be put in as exactly as the teeth are cut in

the wheels and pinions of a clock, then the trundle might divide the wheel exactly; that is to say, the trundle might make a given number of revolutions for one of the wheel, without a fraction. But as any exact number is not necessary in mill-work, and the cogs and rounds cannot be set in so truly as to make all the intervals between them equal, a skilful mill-wright will always give the wheel what he calls a *hunting cog*; that is, one more than what will answer to an exact division of the wheel by the trundle. And then, as every cog comes to the trundle, it will take the next staff, or round, behind the one which it took in the former revolution; and by that means, will wear all the parts of the cogs and rounds which work upon one another equally, and to equal distances from one another, in a little time.

*The Method for setting out a Spur-Wheel and Wallower.*

Draw the pitch lines A 1, B 1, A 2, 2 B, (Plate 4. fig. 1.) then divide them into the number of teeth or cogs required, as  $a b c$ .

Divide one of those distances, as  $b c$ , into seven equal parts, as 1, 2, 3, 4, 5, 6, 7; allow three parts for the thickness of the cogs, as 1, 2, 3, in the cog  $a$ , and four for the thickness of the stave of the wallower: one reason for allowing three parts for the cog, and four for the stave is, the wallower is in general of less diameter than the wheel, therefore subject to more wear, in proportion of the number of cogs to the number of staves; but if there is the same number of staves as of cogs, they may be of equal thickness, as 1, 2, 3, 4, in the stave  $m$ ; (Fig. 2.) the height of the cog is equal to four parts; then divide its height into five equal

parts, as 1, 2, 3, 4, 5, in the cog C; allow three for the bottom to the pitch-line of the cog; the other two parts for epicycloid, so as to fit and bear on the stave equally. The mill-wrights in general put the point of a pair of compasses in the dot 3 of the cog *a*, and strike the line *d e*; then remove the point of the compasses to the point *d*, and strike the curve line 3 *f*, which they account near enough the figure of the epicycloid.

The method for a face-wheel is thus: divide the pitch-line A B (Fig. 2.) into the number of cogs intended, as *a b c*; divide the distance *b c*, into seven equal parts: allow three of those parts for the thickness of the cogs, as 1, 2, 3, in the cog *a*, four for the height, and four for the width, as *d e*, and four for the thickness of the stave *m*; draw a line through the centre of the cog, as the line A I, at S; and on the point 5, describe the line *d e*; remove the compasses to the point A, and draw the line *f g*, which forms the shape of the cog; then shape the cog on the sides to a cycloid, as *d e f g* (Fig. 1.) But this method of setting out the shape of a cog is variable, according to the cycloid in different diameters of wheels.

In common spur-nuts, divide the pitch-line A into twice as many equal parts as you intend teeth, as *a, b, c, d, e* (Fig 3.); with a pair of compasses opened to half the distance of any of those divisions, from the points *a 1, c 3, e 5*, draw the semicircles *a, c, and e*, which will form the ends of the teeth. From the points 2, 4, and 6, draw the semicircles *g h i*, which will form the hollow curves for the spaces; but if the ends of the teeth were epicycloids instead of semicircles, they would act much better.

## THE PENDULUM.

By the *Pendulum* is meant a heavy body suspended by a cord or wire, and made to vibrate or oscillate. It is a very important instrument, from its enabling us to measure very small portions of time, and to regulate the going of clocks.

The vibration of bodies when suspended must have been long observed; but it was Galileo who first noticed the properties which render it so useful, which is a striking proof of the way in which men of genius reflect upon incidents which to others afford no interest. It is said, that while observing the oscillations of a lamp which was hung from the ceiling, he noticed, that although they diminished gradually, yet whether great or small, they were performed in equal times. Struck with this remarkable circumstance, he repeated many experiments with weights hung from cords, and thus developed all those facts which finally rendered the pendulum so valuable. Galileo, as well as the other astronomers of that period, employed the pendulum for measuring time in astronomical observations, but it was reserved for Huygens to apply it to the regulation of clocks.

We shall here consider the pendulum merely as consisting of a weight and a string.

PC (Plate 5. fig. 9.) is a pendulum, consisting of a body P, attached to a thread PC which is fastened to the point C and is moveable round it. If the body P was let free, and not retained by the thread, it would fall in the vertical line PL; but being retained by the thread PC, it is forced to describe the arch PA, which is the segment of a circle, of which PC is the radius.

The body P acquires a velocity in falling through the arch P A, that has a tendency, when it arrives at the point A, to carry it off in the tangent A D; but being prevented from moving in a straight line by the string which continually draws it towards the centre, it is forced to describe the curve A E, which, provided the pendulum were not affected by the resistance of the air, or the friction at the centre, would be exactly similar to the arch P A; that is, it would rise to the same height as it fell from. Having arrived at E, it will fall back again to A, and go on with its acquired velocity to P, and so on, continually backwards and forwards.

Each swing that it makes, is called a *vibration*, or *oscillation*.

If the pendulum vibrated *in vacuo*, and there was no friction at the point of suspension, the vibrations would not only be all equal, but they would continue for ever; but as this is not the case, the vibrations become less and less, till at last the motion totally ceases.

The longer a pendulum is, the slower are its vibrations, and the contrary; consequently, if a pendulum be required to vibrate seconds, it must have a determinate length. This length is found to be 39.13 inches in Britain.

Pendulums of the same length vibrate slower, the nearer they are brought to the equator; because the semi-diameter of the earth's equator is about seventeen miles longer than the axis of the earth, consequently gravity is less at the equator than at the poles; and because the centrifugal force at the equator, arising from the diurnal motion of the earth, being greater than that at the poles, lessens gravity by  $\frac{1}{15}$  part. A pendulum, therefore, to

vibrate seconds at the equator, must be somewhat shorter than at the poles.

When we consider a simple pendulum, or a ball suspended by a string having no sensible weight, we suppose the whole weight of the ball to be collected in its centre of gravity; and the length of the pendulum is the distance from the centre of gravity to the point of suspension.

But when a pendulum consists of a ball, or any other figure, suspended by a metallic or wooden rod, the length of the pendulum is the distance from the point of suspension to a point in the pendulum called the *centre of oscillation*, which does not exactly coincide with the centre of gravity of the ball. The centre of oscillation is that point in the pendulum in which all its force is collected, and to which, if an obstacle were applied, all motion would cease, and would be received by the obstacle.

A single pendulum, consisting of a ball and a thread, whose length is two-thirds of the length of a bar without a ball, will be found to perform its oscillations in equal times with the bar. Hence, a point taken one-third of the length of the bar from the lower end is its centre of oscillation.

The pendulums of clocks usually vibrate in the arcs of circles. It had formerly been thought an advantage to make them vibrate in the arcs of cycloids; but the difficulties that attend the practical application of this principle are such, that there is good reason to think that they produce greater errors in the measurement of time than those they are intended to remedy.

As heat expands, and cold contracts all metals, a pendulum-rod is longer in warm than in cold wea-



ther; and hence a source of irregularity in clocks. Various expedients have been tried for remedying this defect; the best of which is the method of forming the pendulum of bars of brass and steel so placed, that the expansion of one corrects that of the other, and thus preserves the centre of oscillation always in the same place. This is called the *gridiron* pendulum, from its resemblance to a gridiron.

Deal-wood is found to expand very little in the direction of the grain: hence it is much fitter for pendulum-rods than metal. Baking, varnishing, gilding, or soaking them in any melted matter, is said to render them less accurate; but rubbing on the outside with wax and a cloth is recommended.

#### CHRONOMETERS.

Instruments for measuring time are called *Chronometers*, and no class of machines has exercised in a greater degree the genius of mechanics.

The ancients were entirely unacquainted with clocks and watches, and instead of them used sundials, and also *clepsydræ*; the latter were instruments which measured time by the regular dropping of water. Sand-glasses, constructed on the same principle, are still used. It is not exactly known at what period clocks were first invented; and probably so complicated an instrument was the result of repeated trials and improvements by different persons. The oldest clock of which we have any account, is that made by Henry de Wick, a German, for the palace of Charles V. of France. Its date is about 1364. The wheels were of iron, and very large; and it required two men to wind it up. It is also equally uncertain who it

was that first reduced the portable spring clock into a size of a watch, though he is also supposed to have been a German. Watches were common in France before 1544.

The usual distinction of modern chronometers is into *clocks* and *watches*; the latter being very small and portable. When watches are constructed with extraordinary care for astronomical or nautical purposes, they are called *time-keepers*.

Clocks sometimes are made to strike the hour, and sometimes they do not; when watches are made to strike, they are called *repeating watches*.

In chronometers the moving power is of two kinds; either a weight or a spring: the latter only can be employed in portable instruments.

When a weight is the moving power, it is suspended by a cord, which passes several times round a cylinder, which is made to turn, as the weight descends by the action of gravity. Were there no resistance from the wheels, the weight would fall, as all other bodies, with an accelerated motion; but the friction of the teeth and the resistance of the air check this acceleration, which arrives at last at its maximum. But it is necessary, for the exact measurement of time, that all sources of inequality in the motion of the machinery should be removed, and this is effected by a very ingenious contrivance; but which cannot be understood without reference to a figure.

Plate 5. fig. 1. represents the profile of a clock, in which P is the weight that is suspended by a rope that winds about the cylinder or barrel C, which is fixed upon the axis *a a*: the pivots *b b* go into holes made in the plates T S, T S, in which they turn freely. These plates are made of brass or iron, and are connected together by four pillars

Z Z; the whole together being called the frame. On the end of the barrel C, of which a front view is again represented in fig. 2. at R, is a ratchet wheel K K, the inclined teeth of which strike against a click C kept to its place by a slender spring. This click and spring are screwed to a wheel D, which is not fastened on the arbor of the barrel: consequently when the weight pulls downwards, the ratchet wheel pushes the click, and with it the wheel P. But when the weight has run down, and it is necessary to wind it up again, the click suffers the ratchet wheel to pass, while the wheel D stands still.

This wheel D in fig. 2. is the same as D in fig. 1., where the profiles of it and of the ratchet wheel are represented. A small wheel *d* fixed upon an axis *c c* is carried round by the wheel D. A larger wheel E E is fixed upon the same axis *c c*. The wheel E E drives a small pinion *e*, on the axis of which is fixed the wheel F F, which moves the pinion *f*, on the axis of which the scape wheel G H is fixed. The pivots of the pinion *f* play in holes of the plates L, M, which are fixed horizontally to the plates T, S. Thus the motion begun by the weight is transported to the scape wheel G H.

This scape wheel has teeth acting upon it, and suspended over it are two flat pieces called *pallets*, fixed upon a horizontal axis, called the verge. These pallets fall into the teeth of the scape wheel, so that as it moves round they are alternately moved backward and forward, and at the same time they suffer the wheel to pass. Connected with the axis of the pallets by means of the fork X U, is the pendulum A B, which is suspended upon the hook A.

If the pendulum be once put in motion by a push of the hand, it will continue to go alternately back-

wards and forwards, or to vibrate; and if it were not connected with the fork X U, its motion would continue until destroyed gradually by the resistance of the air and the friction on the point of suspension. But as it is joined by the fork to the axis  $rs$  of the pallets, it receives at each vibration a new impulse, which preserves its motion, and it therefore continues to vibrate. Now, as all the vibrations of a pendulum are performed in the same time, the motion of the pallets will be uniform, and consequently they will not suffer the teeth of the scape wheel to pass in an unequal manner. Hence the pendulum is the exact regulator of the motion of the scape wheel, and consequently of the whole train of wheels connected with it. This ingenious combination of the scape wheel and the pallets, is called the *scapement*. As this is a most important part of a clock, various forms of scapements have been invented to insure greater accuracy. That represented in fig. 1. just referred to is called the *crown wheel* and *verge scapement*, from the resemblance of this wheel to a royal diadem. It is the oldest scapement, and used chiefly in common watches and table-clocks. So far we have shown how an equable motion of the machinery is insured. It remains next to point out in what way this is employed to divide and show the time.

As it is known that all the vibrations of the same pendulum are performed in the same times, so also is it known that pendulums vibrate in different times, according to their lengths, long pendulums making their vibrations in longer periods than short ones. Hence the length of a pendulum may be determined that shall make each of its vibrations in a second of time. This length has lately been accurately determined to be in London 39.13829 inches.

The showing the time is contrived by the motion of the indices or hands on the dial-plate; one of which, called the minute-hand, goes completely round the circle in an hour; and the other, called the hour-hand, once in twelve hours. To obtain exactly this degree of velocity in the hands, they are fixed on the ends of axes which turn round by means of wheels attached to them, having teeth on their circumferences; these teeth are connected with that fixed on the axis of the crown wheel; and it is by proportioning the number of these teeth, that the proper degree of velocity is obtained. The minute-hand is fixed on the axis of the wheel E; consequently it must revolve once in an hour. The pivot C of this wheel passes through the plate S T, and continues to *r*: fixed upon the pivot C is a wheel N, which acts upon the wheel O, the pinion of which *p* carries round another wheel *g* that has a hollow axis which goes on the axis of the wheel N and turns on it: this wheel *g* turns round once in twelve hours, and has the hour-hand fixed on it.

The wheel E is driven by the pinion *c* belonging to the axis of the wheel F F, which is moved by the pinion *f* of the crown or scape wheel G H. Supposing, then, that the pendulum makes two vibrations in a second, (which will be what is called a half-second pendulum,) it will make 7200 vibrations in an hour. If the balance wheel consists of 30 teeth, it will turn once in the time that the pendulum makes sixty vibrations; for at every turn of the wheel the same tooth acts once on the pallet I, and once on the pallet K, which occasions two vibrations in the pendulum; and the wheel having 30 teeth, it occasions twice 30 or 60 vibrations; consequently this wheel must perform 120 revolutions in an hour, because 60 vibrations,

which it occasions at every revolution, are contained 120 times in 7200, the number of vibrations performed by the pendulum in an hour.

To determine the number of teeth for the wheels E E, and their pinions *e*, *f*, it must be remarked, that one revolution of the wheel E must turn the pinion *e* as many times as the number of teeth in the pinion is contained in the number of teeth in the wheel. Thus, if the wheel E contains 72 teeth, and the pinion *e* 6, the pinion will make twelve revolutions in the time that the wheel makes one; for each tooth of the wheel drives forward the tooth of the pinion; and when the six teeth of the pinion are moved, a complete revolution is performed; but the wheel E has, by that time, only advanced six teeth, and has still 66 to advance, before its revolution is completed, which occasions eleven more revolutions of the pinion. For the same reason, the wheel F having 60 teeth, and the pinion *f* 6, the pinion will make ten revolutions while the wheel performs one. Now, the wheel F, being turned by the pinion *e*, makes twelve revolutions for one of the wheel E; and the pinion *f* makes ten revolutions for one of the wheel F; consequently the pinion *f* performs 10 times 12, or 120 revolutions, in the time the wheel E performs one. But the wheel G, which is turned by the pinion *f*, occasions 60 vibrations in the pendulum each time it turns round; consequently the wheel G occasions 60 times 120, or 7200 vibrations of the pendulum, while the wheel E performs one revolution; but 7200 is the number of vibrations made by the pendulum in an hour, and consequently the wheel E performs but one revolution in an hour, and so of the rest. From this reasoning, it is easy to discover how a clock may go for any

length of time without being wound up: 1. By increasing the number of teeth in the wheels; 2. By diminishing the number of teeth in the pinions; 3. By increasing the length of the cord that suspends the weight; 4. By increasing the length of the pendulum; and 5. By adding to the number of wheels and pinions. But, in proportion as the time is augmented, if the weight continues the same, the force which it communicates to the last wheel G H, will be diminished. It only remains to take notice of the number of teeth in the wheels which turn the hour and minute-hands. The wheel E performs one revolution in an hour; the wheel N N, which is turned by the axis of the wheel E, must likewise make one revolution in the same time; and the minute-hand is fixed to the socket of this wheel. The wheel N has 30 teeth, and acts upon the wheel O, which has likewise 30 teeth, and the same diameter; consequently the wheel O takes one hour to a revolution: now the wheel O carries the pinion *p*, which has six teeth, and which acts upon the wheel *q q*, of 72 teeth; consequently the pinion *p* makes twelve revolutions while the wheel *q q* makes one; and, of course, the wheel *q q* takes twelve hours to one revolution, and upon the socket of this wheel the hour-hand is fixed.

All that has been said here concerning the revolutions of the wheels, &c. of clocks, is equally applicable to the general movements of watches.

Thus it is plain—*1st*, That the weight P turns all the wheels, and at the same time continues the motion of the pendulum; *2nd*, That the quickness of the motion and wheels is determined by that of the pendulum; *3rd*, That the wheels point out the parts of time divided by the uniform motion of the

pendulum. When the cord upon which the weight is suspended is entirely run down from off the barrel, it is wound up again by a key which goes on the square end of the arbor at Q, by turning it in a contrary direction to that in which the weight descends. For this purpose, the inclined side of the teeth of the wheel R (Fig. 2.) removes the click C, so that the ratchet-wheel R turns while the wheel D is at rest; but as soon as the cord is wound up, the click falls in between the teeth of the wheel D, and the right side of the teeth again acts upon the end of the click, which obliges the wheel D to turn along with the barrel; and the spring A keeps the click between the teeth of the ratchet-wheel R.

In portable table clocks and watches, the moving power, instead of being a weight, is a *spring*, which is coiled up in a spiral manner within a barrel that is connected with a fusee by means of a chain. The chain being fixed at one end of the fusee, and at the other to the barrel, when the machine is winding up, the fusee is turned round, and of course the barrel, on the inside of which is fixed one end of the spring, the other end being fixed to an immoveable axis in the centre. As the barrel moves round, it coils the spring several times about the axis, thereby increasing its elastic force to a proper degree: all this while the chain is drawn off the barrel upon the fusee; and then, when the instrument is wound up, the spring, by its elastic force, endeavouring constantly to unbend itself, acts upon the barrel, and carries it round; by which the chain is drawn off from the fusee, and thus turns it, and consequently the whole machinery. Now, as the spring unbends itself by degrees, its elastic force, by which it affects the fusee, will gradually decrease; and, therefore, unless there was some me-



chanical contrivance in the figure of the superficies of the fusee, to cause the chain to be removed farther from the centre of the fusee as the spring grows weak, so that what is lost in the spring's elasticity is gained in the length of the lever; the spring's force would always be unequal upon the fusee, and thus would turn it, and consequently the whole machinery, unequally. All this is remedied by the conical figure of the fusee. The fusee being acted upon, or put in motion, by an uniform force, the great wheel, which is fixed to it, is put into motion, and that drives the pinion of the centre-wheel, which centre-wheel drives the pinion of the third wheel, and this drives the pinion of the contrate-wheel, and this the pinion of the balance-wheel, which plies the two palettes on the axis of the balance, and keeps the balance in motion.

The balance in a watch is instead of a pendulum in a clock, both serving to govern the motion of the whole machinery. To this balance is fixed a small steel spiral spring, which regulates its motion, and makes it equable; whence it has its name of *regulator*.

It is customary for watch and clock makers to call that part of the movement which is designed for carrying the hands round the dial plate, the *watch part*, or *going part*, in contradistinction to the part of the movement which contributes to the striking of the hour, which they call the *clock part*, or *striking part*.

The several members of the watch parts are, 1. the balance, consisting of the rim, or circular part, and the verge, or spindle, to which belong two palettes, or leaves, that play in the teeth of the crown-wheel. 2. The potence, which is the strong

stud in pocket-watches, whereon the lower pivot of the verge plays, and in the middle of which one pivot of the balance-wheel plays. The bottom of the potence is called the foot; the middle part, the nose; and the other part, the shoulder. 3. The cock, which is the piece covering the balance. 4. The regulator or pendulum spring, which is the small spring in watches underneath the balance. 5. The pendulum (see Plate 5. fig. 8.) whose parts are, the verge; palettes 5, 5; cocks; the rod; the fork; the flat; the bob, or great ball; and the corrector, or regulator, being a contrivance for bringing the pendulum to its nice vibrations. 6. The wheels, which are the crown-wheel in pocket-pieces, and swing-wheel in pendulums, serving to drive the balance or pendulum. 7. The contrate-wheel, which is that next the crown-wheel, &c. and whose teeth and hoop lie contrary to those of other wheels; whence the name. 8. The great or first wheel, which is that which the fusee immediately drives, by means of the chain or string of the spring-box, or barrel; after which are the second wheel, third wheel, &c. Lastly, between the frame and dial plate, is the pinion of report, which is that fixed on the arbor of the great wheel, and serves to drive the dial-wheel, as that serves to carry the hand. The method of calculation is easily understood; for suppose the great wheel goes round once in twelve hours; then, if it is a royal pendulum clock, swinging seconds, we have  $60 \times 60 \times 12 = 43200$  seconds, or beats, in one turn of the great wheel: but because there are 60 beats, or seconds, in one minute, and the seconds are shown by an index on the end of the arbor of the swing-wheel, which, in those clocks, is an horizontal position; therefore it is ne-

cessary that the swing-wheel should have 60 teeth; whence  $4\frac{3}{8} \times 20 = 720$ , the number to be broken into quotients for finding the number of teeth for the other wheels and pinions.

The wheels composing the *going part*, or *clock part*, are:—the great or first wheel E, (Plate 5. fig. 8.) which is moved by the weight or spring at the barrel D: in sixteen or thirty-hour clocks, this has usually pins, and is called the pin wheel; in eight-day pieces, the second-wheel, L, is commonly the pin-wheel, or striking-wheel, which is moved by the former. Next the striking-wheel is the detent-wheel, or hoop-wheel, *m*, having a hoop almost round it, wherein is a vacancy at which the clock locks. The next is the third or fourth wheel, according to its distance from the first, called the warning-wheel *n*. To these must be added the pinion of report *z*, which drives round the locking-wheel, called also the count-wheel, ordinarily with eleven notches in it, unequally distant, to make the clock strike the hours. Besides the wheels, to the clock part belong the ratch; a kind of wheel with twelve large fangs running concentric to the dial-wheel, and serving to lift up the detents every hour, and make the clock strike; the detents, or stops, which being lifted up, and let fall, lock and unlock the clock in striking; the hammer *s*, which strikes the bell R; the hammer-tails T, by which the striking pins draw back the hammers; latches whereby the work is lifted up and unlocked; and lifting pieces, as P, which lift up and unlock the detent O.

The method of calculating the numbers of a piece of clock-work is as follows: 1. Regard need only to be had to the count-wheel, striking-wheel, and detent-wheel, which move round in this pro-

portion: the count-wheel commonly goes round once in twelve or twenty-four hours; the detent-wheel moves round every stroke the clock strikes, or sometimes but once in two strokes: wherefore it follows, that, 2. as many pins as are in the pin-wheel, so many turns has the detent-wheel in one turn of the pin-wheel; or, which is the same, the pins of the pin-wheel are the quotients of that wheel divided by the pinion of the detent-wheel. But if the detent-wheel move but once round in two strokes of the clock, then the said quotient is but half the number of pins. 3. As many turns of the pin-wheel as are required to perform the strokes of twelve hours, (which are 78,) so many turns must the pinion of report have to turn round the count-wheel once; or thus: the quotient of 78 divided by the number of striking pins, shall be the quotient for the pinion of report and the count-wheel; and this is in case the pinion of report be fixed to the arbor of the pin-wheel, which is commonly done. An example will make this easy; 8)48(6 the locking-wheel being 48, the pinion of report 8, the pin-wheel 78, the striking pins are 13, and so of the rest. Note, also, that 78 divided by 13 gives 6, the quotient of the pinion of report. As for the warning-wheel, and fly-wheel, it matters little what numbers they have; their use being only to bridle the rapidity of the motion of the other wheels.

The part of the mechanism of a watch which shows the hour of the day, lies concealed from sight between the upper plate of the watch frame and the dial plate. In this A B C (Plate 5. fig 7.) is the uppermost side of the frame-plate, as it appears when detached from the dial-plate: the

middle of this plate is perforated with a hole, receiving that end of the arbor of the centre wheel which carries the minute-hand. Near the plate is fixed a pinion *a b*, of ten teeth; this is called the pinion of report; it drives a wheel *c d*, of forty teeth; the wheel *c d* carries a pinion *e f*, of twelve teeth; and this drives a wheel *g h*, with thirty-six teeth.

As, in the body of the watch, the wheels every where divide the pinions, here, on the contrary, the pinions divide the wheels, and by that means decrease the motion, which is here necessary; for the hour-hand, which is carried on a socket fixed on the wheel *g h*, is required to move but once round, while the pinion *a b* moves twelve times round. To this end, the motion of the wheel *c d* is one-fourth of the pinion *a b*: again, while the wheel *c d*, or the pinion *e f* goes once round, it turns the wheel *g h* but one-third part round; consequently the motion of *g h* is but one-third of one-fourth of the motion of *a b*: but  $\frac{1}{3}$  of  $\frac{1}{4} = \frac{1}{12}$ , that is the hour-wheel *g h* moves round once in the time that the pinion of report, on the arbor of the centre or minute-wheel, makes twelve motions.

Dr. Franklin contrived a clock to show the hours, minutes, and seconds, with only three wheels and two pinions in the whole movement. The dial-plate (Plate 5. fig. 3.) has the hours engraved upon it in spiral spaces, along two diameters of a circle containing four times 60 minutes. The index *A* goes round in four hours, and counts the minutes from any hour which it has passed to the next following hour. The time, therefore, in the position of the index shown in the figure, is either 30 minutes past twelve, four, or eight; and so, in every other quarter of the circle, it points to the

number of minutes after the hours which the index last left in its motion. The small hand B, in the nich at top, goes round once in a minute, and shows the seconds. The wheel-work of this clock may be seen in Fig. 4. A is the first, or great wheel, containing 160 teeth, and going round in four hours with the index A, in Fig. 3. let down by a hole on its axis. The wheel turns a pinion of ten leaves, which therefore goes round in a quarter of an hour. On the axis of this pinion is the wheel C, of 120 teeth, which goes round in the same time, and turns a pinion, D, of eight leaves, round in a minute, with the second-hand, B, of Fig. 3. fixed on its axis, and also the common wheel E, of 30 teeth, for moving a pendulum (by palettes,) that vibrates seconds as in a common clock. This clock is wound up by a cord going over a pulley on the axis of the great wheel, like a common thirty-hour clock. Many of these very simple machines were constructed, which measured time exceedingly well. It is subject, however, to the inconvenience of requiring frequent winding, by drawing up the weights, and likewise to some uncertainty as to the particular hour shown by the index A. Mr. Ferguson has proposed to remedy these inconveniences by the following construction: in the dial-plate of his clock (Fig. 5.) there is an opening, *a b c d*, below the centre, through which appears part of a flat plate: on this the twelve hours, with their divisions into quarters, are engraved. This plate turns round in twelve hours, and the index A points out the true hour, &c. B is the minute-hand, which goes round the large circle of 60 minutes, whilst the plate, *a b c d*, shifts its place one hour under the fixed index, A. There is another opening, *e f g h*, through which

the seconds are seen on a flat moveable ring, at the extremity of a fleur-de-lis engraved on the dial-plate. A, in Fig. 6. is the great wheel of this clock, containing 120 teeth, turning round in twelve hours. The axis of this wheel bears the plate of hours, which may be moved by a pin passing through small holes drilled in the plate, without affecting the wheel-work. The great wheel A turns a pinion B, of ten leaves, round in an hour, and carries the minute hand, B, on its axis round the dial-plate in the same time. On this axis is a wheel C, of 120 teeth, turning round a pinion D, of six leaves, in three minutes; on the axis of which there is a wheel E, of 90 teeth, that keeps a pendulum in motion, vibrating seconds by palettes, as in a common clock, when the pendulum-wheel has only 30 teeth, and goes round in a minute. In order to show the seconds by this clock, a thin plate must be divided into three times 60, or 180 equal parts, and numbered 10, 20, 30, 40, 50, 60, three times successively, and fixed on the same axis with the wheel of 90 teeth, so as to turn round near the back of the dial-plate; and these divisions will show the seconds through the opening *e f g h*, Fig. 5. This clock will go a week without winding.

*Table and Rules for regulating Clocks.*

By the following Table, clocks and watches may be so regulated as to measure true equal time.

D.	H.	M.	S.	D.	H.	M.	S.
1	0	3	56	16	1	2	54
2	0	7	52	17	1	6	50
3	0	11	48	18	1	10	46
4	0	15	44	19	1	14	42
5	0	19	39	20	1	18	38
6	0	23	35	21	1	22	34
7	0	27	31	22	1	26	30
8	0	31	27	23	1	30	26
9	0	35	23	24	1	34	22
10	0	39	19	25	1	38	17
11	0	43	15	26	1	43	13
12	0	47	11	27	1	46	9
13	0	51	7	28	1	50	5
14	0	55	3	29	1	54	1
15	0	58	58	30	1	57	57

The stars make 366 revolutions from any point of the compass to the same point again, in 365 days and one minute; and therefore they gain a 365th of a revolution every twenty-four hours of mean solar time, near enough for regulating any clock or watch. This acceleration is at the rate of 3 minutes, 55 seconds, 53 thirds, 59 fourths, in 24 hours, or, in the nearest round numbers, 3 minutes 56 seconds, by which quantity of time every star comes round sooner than it did on the day before. Therefore, if you mark the precise moment shown by a clock or watch when any star vanishes behind a chimney, or any other object, as seen through a small hole in a thin plate of metal fixed in a window-shutter; and do



this for several nights successively (as suppose twenty); then if at the end of that time the star vanished as much sooner than it did the first night by the clock, as answers in the time denoted in the table for so many days, the clock goes true, otherwise not. If the difference between the clock and the star be less than the table shows, the clock goes too fast; if greater, it goes too slow, and must be regulated accordingly, by letting down or raising the ball of the pendulum, by little and by little, turning the screw-nut under the ball, till you find it keeps true equal time. Thus, supposing the star should disappear behind a chimney any night when it is twelve by the clock, and that on the twentieth night afterward the same star should disappear when the time is 41 minutes 22 seconds past ten by the clock, which being subtracted from 12 hours 0 minutes 0 seconds, leaves remaining 1 hour 18 minutes 38 seconds for the time the star is then faster than the clock: look in the table, and against 20, in the left-hand column, you will find the acceleration of the star to be 1 hour 18 minutes 38 seconds, agreeing exactly with what the difference ought to be between the clock and star; which shows that the clock measures true equal time, and agrees with the mean solar time, as it ought to do.

Amongst the most extraordinary pieces of modern clock-work, are those at Strasburgh and Lyons, which are very eminent for the richness of their furniture, and the variety of their motions and figures. In the former a cock claps his wings, and proclaims the hour; and the angel opens a door, and salutes the Virgin, and the Holy Spirit descends on her, &c. In the latter, two horsemen encounter, and beat the hour on each other; a

door opens, and there appear on the theatre the Virgin, with Jesus Christ in her arms ; the magi, with their retinue, marching in order, and presenting their gifts, two trumpeters sounding all the time, to proclaim the procession. These, however, were excelled by two, which were lately made by English artists, and sent as a present from the East India Company to the Emperor of China. These clocks were in the form of chariots, in which were placed, in a fine attitude, a lady leaning her right hand upon a part of the chariot ; under which is a clock of curious workmanship, little larger than a shilling, that strikes, repeats, and goes eight days. Upon her finger sits a bird finely modelled, and set with diamonds and rubies, with its wings expanded in a flying posture, and which actually flutters for a considerable time, on touching a diamond button below it ; the body of the bird (which contains part of the wheels, that in a manner give life to it) is not the size of the sixteenth part of an inch. The lady holds in her left hand a gold tube, not much thicker than a large pin, on the top of which is a small round box, to which a circular ornament set with diamonds, not larger than a sixpence, is fixed, which goes round near three hours in a constant regular motion. Over the lady's head, supported by a small fluted pillar, no bigger than a quill, are two umbrellas ; under the largest of which a bell is fixed, at a considerable distance from the clock, and seeming to have no connection with it, but from which a communication is secretly conveyed to a hammer, that regularly strikes the hour, and repeats the same at pleasure, by touching a diamond button fixed to the clock below. At the feet of the lady is a gold dog, before which, from the point of the chariot, are two birds, fixed

on spiral wings ; the wings and feathers of which are set with stones of various colours, and appear as if flying away with the chariot, which, from another secret motion, is contrived to run in a straight, circular, or any other direction. A boy, that lays hold of the chariot behind, seems also to push it forward. Above the umbrella, are flowers and ornaments of precious stones, and it terminates with a flying dragon set in the same manner. The whole was of gold, most curiously executed, and embellished with rubies and pearls.

## WHEEL CARRIAGES.

It is very probable, that, in the infancy of the arts, sledges were used before wheels were invented, or at least before the application of them became general. Even now, indeed, sledges are employed for certain purposes in our own country, notwithstanding the number of wheel carriages used in it from time immemorial.

In some of the cold climates, where ice is to be met with in considerable quantity, and the ground is covered with frozen snow for a great part of the year, sledges are much in use, and run upon the smooth surface of the earth with as great ease as wheels run upon the ordinary ground. Upon very smooth ice, indeed, or upon any other body perfectly smooth, wheels would not turn readily ; for the only reason why they turn in the ordinary way, is the continual inequalities they meet with.

On common roads, wheels meet with obstructions at the bottom, which retard that part ; the upper part is in consequence drawn forward, and a circulating motion takes place.

The advantage of wheels over sledges may be understood from the following considerations. A sledge, in sliding over a plane, suffers a friction equivalent to the distance through which it moves; but if we apply to it an axle, the circumference of which is six inches, and wheels of eighteen feet in circumference, it is clear, that when the carriage moves eighteen feet over the plane, the wheels make but one revolution; and as there is no sliding of parts between the plane and the wheels, but only a mere change of surface, no friction can take place there, the whole being transferred to the nave acting on the axle so, that the only sliding of parts has been betwixt the inside of the nave and the axle; which, if they fit one another exactly, is no more than six inches; and hence it is plain, that the friction must be reduced in the proportion of one to thirty-six. Another advantage is also gained; by having the surfaces confined to so small an extent, by which means they may be more easily kept smooth, and fitted to each other. The only inconvenience is the height of the wheels, which must in all cases be added to that of the carriage itself.

By means of this circulatory motion, the friction becomes very much less than what it would be if the weight were drawn along the ground upon a sledge; insomuch, that a four wheeled carriage may be drawn with five times as much ease as one that slides as a sledge upon the same surface.

By applying wheels to a carriage, the friction is lessened in the proportion of the diameters of the axles and hollow parts of the naves to that of the wheels.

Large wheels have also the advantage over small ones in overcoming obstacles, because they act as

levers, in proportion to their various sizes. All wheels, but especially small ones, are apt to sink into the ground over which they pass, and thus produce a constant obstacle to their progress, which the large ones most easily overcome.

In all four-wheeled carriages, the fore-wheels are made of a less size than the hind ones, in order to enable them to turn in less room; but the carriage would go much easier, if the fore-wheels were as high as the hind ones.

It is plain, that the small wheels must turn as much oftener round than the great ones, as their circumferences are less. And, therefore, when the carriage is loaded equally heavy on both axles, the fore-axle must sustain as much more friction, and consequently wear out as much sooner than the hind axle, as the fore-wheels are less than the hind ones. And though this points out that the greatest weight should be laid upon the large wheels, yet it is generally the practice to put the greatest load over the small wheels, which not only makes the friction greatest where it should be least, but also presses the fore-wheels deeper into the ground than the hind wheels, notwithstanding the former are with more difficulty drawn out of it than the latter.

It is true, that when the road is much up-hill, there is danger in loading too much the hind wheels, least the fore-wheels should be tilted up.

It is well known that a great outcry was raised by the generality of the carriers, against the broad wheel act; and that it was difficult to persuade them to comply with it, even though they were allowed to draw with more horses, and carry greater loads than usual. Their principal objection was, that, as a broad wheel must touch the ground in a

great many more points than a narrow one, the friction must, of course, be just so much the greater, and consequently there must be so many more horses to draw the waggon. But they did not consider, that, if the whole weight of the waggon and the load in it bear upon a great many points, each sustains a proportionally less degree of weight and friction, than when it bears only upon a few points; so that what is wanting in one, is made up in the other; and, therefore, the friction will be just equal under equal degrees of weight, as may be shown by the following easy experiment:

Let one end of a piece of packthread be fastened to a brick, and the other end to a common scale for holding weights; then put the brick edgeways on the table, and let the scale hang over the side; put as much weight into the scale as will just draw the brick along the table. Then taking back the brick to its former place, lay it *flat*, and leave it to be acted on by the weight in the scale as before, and it will draw it along with the same ease as when it lay upon its edge. In the former case, the brick may be considered as a narrow wheel on the ground, and in the latter as a broad wheel. And since the brick is drawn along with equal ease, whether its broad side or narrow edge touch the table, it shows that a broad wheel might be drawn along the ground with the same ease as a narrow one (supposing them equally heavy,) even though they should drag, and not roll, as they go along.

As narrow wheels are always sinking into the roads, they must be considered as constantly going up-hill, even on level ground; and their sides must sustain a great deal of friction by rubbing against the ruts. But both these inconveniences are

avoided by using broad wheels ; which, instead of cutting and ploughing up the roads, roll them smooth, and harden them, as experience testifies in places where both have been used.

If the wheels were always to go upon smooth and level ground, the best way would be to make the spokes perpendicular to the naves and to the axles ; because they would then bear the weight of the load perpendicularly, which is the strongest way for wood. But because the ground is generally uneven, one wheel often falls into a cavity, or rut, when the other does not ; and then it bears much more of the weight than the other does ; in which case, concave, or dishing-wheels, are best ; because when one falls into a rut, and the other keeps upon high ground, the spokes become perpendicular in the rut, and therefore have the greatest strength when the obliquity of the load throws most of its weight upon them ; whilst those on the high ground have less weight to bear, and therefore need be at their full strength : so that the usual way of making the wheels concave is best.

## HYDROSTATICS.

---

By hydrostatics, in general, is meant the science which treats of the mechanical properties of fluids. Strictly speaking, however, *hydrostatics* treats of the weight and equilibrium of fluids *at rest*. When that equilibrium is destroyed, motion ensues; and the science which considers the laws of fluids *in motion*, is called *hydraulics*.

A fluid is defined to be, *a body whose parts yield to any impression, and, in yielding, are easily moved amongst each other.*

Fluids are of two kinds: non-elastic and incompressible fluids, such as water, oil, mercury, &c.; and elastic and compressible fluids, as air of different sorts.

Here it must be observed that the class of fluids denominated incompressible, are not absolutely so; but they are compressible in so slight degree, that it may be disregarded in practical cases, so that this division is still retained.

From the expansion and contraction of water by heat and cold, it might have been inferred that it was compressible by some means: but from some experiments formerly made by the Academy



Del Cimento, at Florence, its absolute incompressibility was thought to be proved.

A globe of gold was filled with water, and hammered violently; but the water oozed through the gold, and stood like dew upon the surface. Lord Bacon had, however, tried the same experiment with a globe of lead, and with a similar result; but he drew from it the opposite conclusion.

Mr. Canton, about fifty years ago, made some experiments which showed that water was compressible in a very small degree: and Mr. Zimmerman at Leipsic, in 1779, found that sea water when inclosed in the cavity of a strong iron cylinder, and pressed by a force equal to a column of sea water 1000 feet high, was compressed  $\frac{1}{148}$  part of its own bulk.

It has already been stated that the cause of fluidity does not appear to consist in the figure of the particles, but in their want of cohesion.

Different fluids have different degrees of tenacity or fluidity, according to the facility with which the particles may be moved amongst each other. Water and mercury may be considered as among the most perfect fluids. Others, as oil, mucus, &c. are viscous or imperfect fluids.

It is from the imperfect cohesion of fluids, that, when in small quantities, they arrange themselves in a spherical manner, and form drops.

Although every one knows that all fluids have weight, and gravitate when considered as a whole, it being evident that a vessel weighs more when full than when empty, yet, in the early times of philosophy, it was an opinion that the parts of fluids did not gravitate upon each other, and that a portion of water lost its gravity when plunged

under more water. A simple experiment, however, will confute this idea.

Suspend from a balance an empty phial, corked, and loaded so as to sink in water, and counterpoise it by an equal weight in the opposite scale, when it is immersed in the water; then pull out the cork, and the water will rush in and fill the phial, but the equilibrium of the balance will be destroyed; and it will require as much weight to restore the equilibrium, as the real weight of the water in the phial; thus proving, that the water in the phial lost none of its weight by being surrounded by a fluid of the same kind.

Though fluids are subject to the same laws of gravity with solids, yet their want of cohesion occasions some peculiarities.

The parts of a solid are so connected together, as to form but one and the same whole; and their effort is, as it were, concentrated in a single point, called the centre of gravity. This is not the case with fluids. Their parts gravitate independently of each other. And hence it is, that the surface of a fluid contained in an open vessel is always level, or parallel to the horizon.

Fluids have this remarkable property, that they press not only in common with solids perpendicularly, but also upwards, sideways, and in every direction, equally.

To confirm this by experiment, take a glass tube open at both ends, and, stopping one end with your finger, immerse the other in water. The water will be prevented from rising far in the tube by the air which is contained in it; but if you take away your finger from the upper end, the air within the tube will be suffered to escape, and the water

will rise in the tube to the same level as it is in the vessel, being pressed upwards by the surrounding water. The same effect will take place, if you incline the tube in any direction, or if you make use of tubes bent in any manner possible; still you will find that the water within them will rise to the same height as in the external vessel.

If you force water with the bended tube A B (Plate 8. fig. 13.) the water will stand at the same height in both legs of the tube; and were the branches ever so numerous, yet, if they communicated with each other, the water would stand at the same level in all of them.

As fluids press equally in every direction, it follows that the horizontal bottom of a vessel sustains just the pressure of a column of the fluid, whose base is the area of the bottom of the vessel, and whose perpendicular height is equal to the depth of the fluid. Thus, in the vessel A B (Plate 8. fig. 1.) the bottom C B does not sustain a pressure equal to the whole quantity of fluid contained in the vessel, but only of a column whose base is C B (Fig. 2.) and height C E. Also in the vessel F G, the bottom G H sustains a pressure equal to what it would be if the vessel were as wide at the top as bottom.

This leads to what is called the *hydrostatic paradox*, which is so denominated, because at first view it seems paradoxical; but it results from the nature of fluids, which press every way alike.

It is, that a *quantity of fluid, however small, may be made to counterpoise the greatest quantity.* Thus, if to a wide vessel A B (Plate 8. fig. 3.) you attach a tube C D communicating with the vessel, and then pour water into either of them, you will find that

it will always stand at the same height in both, consequently there is an equilibrium between them. And whatever shape the vessels are of, the effect will be the same.

It may also be illustrated in this manner :

Let  $ABDG$  represent a cylindrical vessel, to the inside of which is fitted the cover  $C$  (Fig. 4.) which, by means of leather at the edge, will easily slide up and down in the internal cavity without permitting any water to pass between its edges and the surface of the cylinder. In the cover is inserted the small tube  $CF$ , which is open at top, and communicates with the inside of the cylinder beneath the cover at  $C$ . The cylinder is filled with water, and the cover put on. Then, if the cover be loaded with the weight, suppose of a pound, it will be depressed, the water will rise in the tube to  $E$ , and the weight will be sustained. If another pound be added, the water will rise to  $F$ , and the weight will be sustained, and so on, according to the weight added, and the length of the tube. Now, the weight of the water in the tube is but a few grains, yet its lateral pressure serves to sustain as much as the weight of a column of water whose base is equal to that of the cylinder, and height equal to that in the tube. Thus, the column  $EC$  produces a pressure in the water contained in the cylinder, equal to what would have been produced by the column  $AadD$ ; and as this pressure is exerted every way equally, the cover will be pressed upwards with a force equal to the weight of  $AadD$ ; consequently if  $AadD$  would weigh a pound,  $EC$  will sustain a pound; and the like of other heights and weights. And by diminishing the diameter of the tube, any

quantity of water, how small soever, will sustain any weight, however large.

The same may be shown thus: let  $A G B D$  represent a hollow cylinder of wood, which nearly fills the cavity. In the cylinder, suppose a little water, whose surface is  $g b$  (Plate 8. fig. 5.); then, if the wooden cylinder be put into the hollow one, the water will rise between the surfaces to  $a$  and  $d$ , and the wood will be sustained floating. The nearer the wooden cylinder approaches to the size of the cavity, the less water is necessary for the experiment.

The *hydrostatic bellows* is perhaps the best machine for demonstrating the upward pressure of fluids. It consists of two thick oval boards (Plate 8. fig. 6.) each about 16 inches broad, and 18 inches long, covered with leather, to open and shut like a common bellows, but without valves; only a pipe about three feet high is fixed into the bellows. Let some water be poured into the pipe; it will run into the bellows, and separate the boards a little: then lay three weights, each weighing 100 pounds, upon the upper board, and pour more water into the pipe, which will run into the bellows, and raise up the board with all the weights upon it; and if the pipe be kept full until the weights are raised as high as the leather which covers the bellows will allow them, the water will remain in the pipe, and support all the weights, even though it should weigh no more than a quarter of a pound, and they 300 pounds: nor will their utmost weight cause the boards to descend, and force the water out at the top of the pipe.

The reason of this will be made evident, by con-

sidering what has been already said of the result of the pressure of fluids of equal heights, without any regard to the quantities. For, if a hole be made in the upper board, and a tube be put into it, the water will rise in the tube to the same height that it does in the pipe; and would rise as high (by supplying the pipe) in as many tubes as the board could contain holes. Now, suppose only one hole to be made in any part of the board, of an equal diameter with the bore of the pipe, and that the pipe holds just one quarter of a pound of water; if a person put his finger upon the hole, and the pipe be filled with water, he will find his finger pressed upward with a force equal to a quarter of a pound; and as the same pressure is equal upon all equal parts of the board, each part whose area is equal to the area of the hole, will be pressed upward with a force equal to that of a quarter of a pound; the sum of all which pressures against the under side of an oval board 16 inches broad and 18 inches long, will amount to 300 pounds; and, therefore, so much weight will be raised up and supported by a quarter of a pound of water in the pipe.

Hence, if a man stand upon the upper board, and blow into the bellows through the pipe, he will raise himself upward upon the board: and the smaller the bore of the pipe is, the easier he will be able to raise himself. Then, by clapping his finger on the top of the pipe, he can support himself as long as he pleases, provided the bellows be air-tight, so as not to lose what is blown into it.

It is from the pressure of fluids in all directions, that a solid body specifically lighter than a fluid,

(that is, lighter than an equal bulk of the fluid,) will ascend to the surface, if immersed below it. For when such a solid is immersed in a fluid, it presses downwards with a force equal to the weight of a column composed of the body itself, and that portion of the fluid which lies upon it; and the fluid presses upwards against the body with a force equal to a column of itself alone: hence the body will rise with a force equal to the difference between the pressures of these two columns.

In the same manner, a body specifically heavier than a fluid must sink in it, since it must press downwards more than the fluid presses against it upwards.

Thus we see the reason why a piece of cork is more buoyant than a piece of oak, and also why it is easier to swim in salt than fresh water.

If by any contrivance, the force with which a body presses downwards, and that with which the fluid presses upwards, can be reduced to an equality, then the body will remain suspended in the fluid. Thus a piece of lead may be made to swim in water, by immersing it to a proper depth, and keeping the water from getting above it. Let C D (Plate 8. fig. 7.), be a glass tube open throughout; and, G, a flat piece of lead, exactly fitted to the lower end of the tube, but not to go within it, with a wet leather between the lead and the tube, to make it air-tight. Let this leaden bottom be half an inch thick, and held close to the tube, by pulling the packthread, L, upward with one hand, whilst the tube is held in the other by the upper end. In this situation, let the tube be immersed in water, in the glass vessel, A B, to the depth of six

inches below the surface of the water at *K*; and then the leaden bottom, *G*, will be plunged to the depth of somewhat more than eleven times its own thickness. Holding the tube at that depth, you may let go the thread at *L*, and the lead will not fall from the tube, but will be kept to it by the upward pressure of the water below it, occasioned by the height of the water at *K*, above the level of the lead: for as lead is 1.133 times as heavy as its bulk of water, and is in this experiment immersed to a depth somewhat more than 1.133 times its thickness, and no water getting into the tube between it and the lead, the column of water, *G a b*, below the lead, is pressed upward against it by the water all around the tube; which water being a little more than 1.133 times as high as the lead is thick, is sufficient to balance and support the lead. If a little water be poured into the tube upon the lead, it will increase the weight upon the column of water under the lead, and cause the lead to fall from the tube to the bottom of the glass vessel. Or if the tube be raised a little in the water, the lead will fall by its own weight, which will then be too great for the pressure of the water round the tube, upon the column of water below it.

In like manner, a piece of wood may be made to lie at the bottom of water, by keeping the water from pressing on its under surface. Let two pieces of wood be planed quite flat, so as no water may get between them when they are put together; let one of the pieces, as *a b*, be cemented to the bottom of the vessel, *A B* (Fig. 7.), and the other piece be laid flat and close upon it, and held down to it by a stick, whilst water is poured into a vessel; then remove the stick, and the upper piece



of wood will not rise from the lower one; for as the upper one is pressed down, both by its own weight and the weight of all the water over it, whilst the contrary pressure of the water is kept off by the wood under it, it will lie as still as a stone would do in its place. But if it be raised ever so little at any edge, some water will then get under it, which being acted upon by that above, will immediately press it upward; and as it is lighter than its bulk of water, it will rise and float upon the surface.

If two fluids of different densities are included in the separate branches of a bent tube, they will balance each other, when the altitudes above their common junction are reciprocally proportional to their specific gravities: thus a column of mercury will balance fourteen its height of water, because mercury is fourteen times as heavy as water.

The most elegant and useful application of the principle of the hydrostatic paradox is, in Bramah's hydrostatic press, represented Plate 25. fig. 3.: *a b* is a small forcing pump, the piston of which is worked by the handle or lever, *A B*. This pump forces the water through the pipe, *b c d*, into the bottom of the thick pipe, *E F*: also containing a piston that exactly fits the inside; to this piston is attached a rod, *G*, working through a collar of leathers in the top of the wide cylinder: the rod, *G*, performs the work by pressing against whatever is required. The power of this machine will be in proportion to the areas of the surfaces of the two pistons, or as the squares of their diameters. Thus supposing the diameter of the large cylinder to be six inches, and that of the small cylinder to be  $\frac{1}{4}$  inch, the diameters will be as 1 to 24, and the areas will be as 1 to 576. Therefore, if the small piston be forced

down with a power equal to one ton, then the rod of the great cylinder will be forced up with a power equal to 576 tons. To increase the power of this press to any degree, it is only necessary to make the great cylinder exceed the smaller in any required proportion: and this machine has the advantage of great simplicity and little loss from friction.

Mr. Bramah has also employed the same principle to the construction of a jack for raising stones; and also of a crane, by adding a rack to the rod of the great piston, which drives a wheel that has a chain passing over a jib.

From the principles above described of the pressure of fluids, water is conveyed by means of pipes to any distance, and to any height not exceeding the reservoir: thus in Plate 25. fig. 5. A represents a reservoir of water, either supplied by natural streams, or kept full by forcing engines: the water may be conveyed by the pipe, B C D, across the valley to the house at D, and will rise to the top of the building, provided that it is not higher than the reservoir; whereas, if the pipe be continued to the house, E, it will not rise to the top, because it stands higher than the level of the reservoir.

When it is required to carry the water higher up, the reservoir must be also raised higher: sometimes water is forced up to the top of a town, to supply houses on a high ground.

On this principle may be explained the rising of water in springs. The vapours raised by evaporation from the sea form clouds, which afterwards descend in rain on the hills and high ground: the water so formed, percolates through the soil, and sinks into the looser and more porous strata: it

thus continues to go downwards, until stopped by an impervious bed, as rock or clay, and following the course of this bed, it breaks out on the surface, at the first place where the soil permits its exit. The existence of springs, therefore, always requires that there shall be ground on a higher level, together with an alternation of hard and soft beds.

#### OF SPECIFIC GRAVITIES.

By the *specific gravities* of bodies is meant the relative weights which equal bulks of different bodies have to each other. It is usual to compare them with that of water, as it is by weighing bodies in water that their specific gravities are found.

The method of ascertaining the specific gravities of bodies was invented by Archimedes upon the following occasion.

Hiero, king of Syracuse, having given a quantity of pure gold to a workman to make a crown of, suspected that he had kept part of the gold, and adulterated the crown with a baser metal. He applied to Archimedes to discover the fraud, who having long studied it in vain, accidentally hit upon a method of ascertaining it. Going one day into a bath, he took notice that the water rose in it, and immediately reflected, that any body of an equal bulk with himself would have raised the water just as much; though a body of equal weight, but not of equal bulk, would not raise it so much. From this idea, he conceived a mode of finding out what he so much wished, and was so transported with joy, that he ran out of the bath, naked as he was, crying, "I have found it, I have found it!"

Since gold is the heaviest of all known metals, it must be of less bulk, according to its weight, than any other metal. And therefore he desired that a mass of pure gold, equally heavy with the crown when weighed in air, should be weighed against it in water, and if the crown was not alloyed, he conceived it would counterpoise the mass of gold when they were both immersed in water, as well as it did when they were weighed in air. But upon making the trial, he found that the mass of gold weighed much heavier in water than the crown did; and not only so, but that, when the mass and crown were immersed separately in one vessel of water, the crown raised the water much higher than the mass did; which showed it to be alloyed with some lighter metal that increased its bulk.

A body immersed in a fluid will sink to the bottom, if it be heavier than its bulk of the fluid. If it be suspended therein, it will lose as much of what it weighed in air, as its bulk of the fluid weighs. Hence, all bodies of equal bulks, which would sink in fluids, lose equal weights when suspended therein; and unequal bodies lose in proportion to their bulks.

The instrument used for finding the specific gravities of bodies, is called the *hydrostatic balance*. (Plate 8. fig. 8.)

It differs very little from a common balance that is nicely made; only it has a hook at the bottom of one of the scales, on which different substances that are to be examined may be hung by horse-hairs, or silk threads, so as to be immersed in a vessel of water, without wetting the scale.

If a body thus suspended under the scale at one end of the balance, be first counterpoised in air by weights in the opposite scale, and then immersed in

water, the equilibrium will be immediately destroyed; then, if as much weight be put into the scale from which the body hangs, as will restore the equilibrium, without altering the weights in the opposite scale; that weight which restores the equilibrium, will be equal to the weight of a quantity of water as large as the immersed body; and if the weight of the body in air be divided by what it loses in water, the quotient will show how much that body is heavier than its bulk of water. Thus, if a guinea, suspended in air, be counterbalanced by 129 grains in the opposite scale of the balance, and then, upon its being immersed in water, it becomes so much lighter as to require  $7\frac{1}{4}$  grains put into the scale over it, to restore the equilibrium, it shows that a quantity of water of equal bulk with the guinea, weighs  $7\frac{1}{4}$  grains, or 7.25; by which divide 129 (the weight of the guinea in air), and the quotient will be 17.793; which shows that the guinea is 17.793 times as heavy as its bulk of water. And thus, any piece of gold may be tried, by weighing it first in air, and then in water; and if upon dividing the weight in air by the loss in water, the quotient comes out to be 17.793, the gold is of the standard value; if the quotient be 18, or between 18 and 19, the gold is very fine; but if it be less than 17, the gold is too much alloyed with other metal.

By this method the specific gravities of all bodies that will sink in water may be found; first weighing the body in air, then in water, and dividing the weight in air by the loss in water.

But as to those which are lighter than water, as most sorts of wood are, the following method must be taken. A sort of pincers, or tongs, must be provided, to retain the substance to be examined,

under water. First weigh the body in air; then having balanced the tongs in water, fix to it the body to be weighed, which being lighter than water, will raise the tongs, and cause the other scale to preponderate. Observe the loss of weight of the body in water, and proceed as before.

There are some things that cannot be weighed in this manner, such as quicksilver, fragments of diamonds, &c.: these must be put into a glass bucket hanging to the scale.

The *Hydrometer* is the most eligible instrument for finding the specific gravity of *fluids*.

The most common hydrometer consists of a copper ball, B, (Plate 8. Fig. 9.) to which is soldered a brass wire, A B, one quarter of an inch thick. The upper part of this wire being filed flat, is marked *proof*, at *m* (Fig. 10.), because it sinks exactly to that mark in proof spirits. There are two other marks at A and B (Fig. 9.), to show whether the liquor be one-tenth above, or below proof, according as the hydrometer sinks to A, or rises to B, when a brass weight, C, is screwed to its bottom. There are other weights to screw on, which show the specific gravity of different fluids.

The round part of the wire above the ball may be marked so as to represent river-water when it sinks to R W (Fig. 10.), the weight which answers to that water being then screwed on; and when put into spring-water, mineral-water, sea-water, and water of salt springs, it will gradually rise to the marks S P, M I, S E, S A; on the contrary, when it is put into Bristol-water, rain-water, Port-wine, and Mountain-wine, it will successively sink to the marks *b r*, *r a*, *p o*, *m o*.

Another sort of hydrometer is represented in Plate 8. fig. 11.; which is calculated to ascertain

the specific gravity of fluids with greater precision; it consists of a large hollow ball, B, with a smaller bolt, *b*, screwed on to its bottom, partly filled with mercury, or small shot, in order to render it but little specifically lighter than water. The larger ball has also a short neck at C, into which is screwed the graduated brass wire, A C, which, by a small weight at A, causes the body of the instrument to descend in the fluid with part of the stem. When this instrument is swimming in the liquor contained in the jar, I L M K, the part of the fluid displaced by it will be equal in bulk to the part of the instrument under water, and equal in weight to the whole instrument. Now, suppose the weight of the whole to be 4000 grains, it is evident we can by this means compare the different dimensions of 4000 grains of several sorts of fluids. For if the weight at A be such as will cause the ball to sink in rain-water, until its surface come to the middle point of the stem, 20; and after that, if it be immersed in common spring-water, and the surface be observed to stand at one-tenth of an inch below the middle point, 20, it is apparent that the same weight of each water differs only in bulk, by the magnitude of one-tenth of an inch in the stem.

Now, suppose the stem to be ten inches long, and weigh 100 grains, then every tenth of an inch will weigh one grain; and as the stem is of brass, which is about eight times heavier than water, the same bulk of water will be equal to one-eighth of a grain, and consequently to one-eighth of  $\frac{1}{8000}$  part; that is,  $\frac{1}{37500}$  part of the whole bulk. This instrument is capable of still greater precision, by making the stem or neck consist of a flat thin slip of brass, instead of one that is cylindrical; for by this means we increase the surface, which is the

most requisite circumstance, and diminish the solidity, which necessarily renders the instrument still more accurate.

Proof-spirit consists of pure spirit with a little water; that is, such as, when poured on gunpowder and set on fire, will burn all away; and permit the powder to take fire and flash, as in open air. But if the spirit be not so highly rectified, there will remain some water, which will make the powder wet, and unfit to take fire. Proof-spirit of any kind weighs seven pounds twelve ounces per gallon.

The common method of shaking the spirits in a phial, and raising a head of bubbles, to judge by their manner of rising or breaking, whether the spirit be proof or near it, is very fallacious.

Syke's Hydrometer, represented Plate 25. fig. 4. is that now used by the excise officers in collecting the revenue. Weights are made to slide on the conical stem below the ball; and the graduation of the upper stem shows the specific gravity of the liquor.

*Table of Specific Gravities.*

Distilled water,	-	-	-	-	-	1.000
Sea water,	-	-	-	-	-	1.026
Water of the Dead Sea,	-	-	-	-	-	1.240
Crude platina, in grains,	-	-	-	-	-	15.602
Platina, purified and fused,	-	-	-	-	-	19.500
———— hammered,	-	-	-	-	-	20.377
———— drawn into wire,	-	-	-	-	-	21.042
———— laminated,	-	-	-	-	-	22.069
Pure gold, cast,	-	-	-	-	-	19.258
———— hammered,	-	-	-	-	-	19.362
Standard gold,	-	-	-	-	-	17.486
———— hammered,	-	-	-	-	-	17.589
Mercury,	-	-	-	-	-	13.568



Pure silver, cast, - - - - -	10.474
————— hammered, - - - - -	10.511
Standard silver in coin, - - - - -	10.391
Lead, fused, - - - - -	11.352
Bismuth, - - - - -	9.823
Nickel, - - - - -	8.660
Brass, cast, - - - - -	8.396
———— in wire, - - - - -	8.544
Cobalt, - - - - -	7.812
Copper, fused, - - - - -	7.788
———— drawn into wire, - - - - -	8.878
Tin, English, fused, - - - - -	7.291
————, hammered, - - - - -	7.299
Malacca tin, fused, - - - - -	7.296
———— hammered, - - - - -	7.306
Iron, cast, - - - - -	7.207
———— bar, - - - - -	7.788
Steel, soft, and not hammered, - - - - -	7.840
———— hardened, - - - - -	7.816
Zinc, - - - - -	7.191
Manganese, - - - - -	6.850
Antimony, - - - - -	6.702
Tungsten, - - - - -	6.678
Tellurium, - - - - -	6.115
Molybdena, - - - - -	6.000
Arsenic, - - - - -	5.763
Zircon, - - - - -	4.300
Barytes, - - - - -	4.200
Strontian, - - - - -	3.700
Corunda, - - - - -	3.000
Silex, - - - - -	2.660
Magnesia, - - - - -	2.300
Lime, - - - - -	2.300
Alumine, - - - - -	2.000
Oriental ruby, - - - - -	4.283
Garnet, - - - - -	4.188

Oriental topaz, - - - -	4.010
——— sapphire, - - - -	3.994
Emerald of Peru, - - - -	3.775
Beryl, - - - -	3.549
Spinel ruby, - - - -	3.760
Corundum, - - - -	3.710
Schorl, - - - -	3.363
Diamond, - - - -	3.521
Rock-Crystal, - - - -	2.650
Agate, - - - -	2.590
Onyx, - - - -	2.376
Mica - - - -	2.792
Common slate, - - - -	2.672
Calcareous spar, - - - -	2.715
Alabaster, - - - -	2.730
White marble, - - - -	2.716
Limestones, from - - - -	1.386
——— to - - - -	2.390
Chalk, - - - -	2.225
Brick, - - - -	2.000
Lithomarge, - - - -	2.500
Heavy spar - - - -	4.474
Fluor-spar, - - - -	3.180
Mountain-cork, - - - -	9.993
Pumice-stone, - - - -	0.914
Green glass, - - - -	2.620
English crown-glass, - - - -	2.520
White flint-glass, English, - - - -	3.290
Ditto, for achromatic uses, - - - -	3.437
White glass, French, - - - -	2.892
Augite, - - - -	2.332
Basalt of the Giant's causeway, - - - -	2.846
Dry ivory, - - - -	1.825
Sulphur, - - - -	1.990
Phosphorus, - - - -	1.714
Ebony, - - - -	1.117

Yellow amber, - - -	1.078
Common spirit of wine, - -	0.837
Pure spirit of wine, - - -	0.820
Concentrated sulphuric acid, - -	2.125
———— nitrous acid, - - -	1.580
———— marine acid, - - -	1.194
———— fluoric acid, - - -	1.500
Black coal, - - -	1.308
Cannel coal, - - -	1.270
Bone of an ox, - - -	1.658
Oil of olives, - - -	0.915
— of sweet-almonds, - - -	0.917
Spirits of turpentine, - - -	0.870
Linseed oil, - - -	0.940
Naptha, - - -	0.708
Gum-elastic, - - -	0.393
Camphor, - - -	0.989
Yellow wax, - - -	0.965
White ditto, - - -	0.969
Spermaceti, - - -	0.943
Tallow, - - -	0.942
Dry oak, - - -	0.925
Yew, - - -	0.788
Dry ash, - - -	0.800
— maple, - - -	0.755
— elm, - - -	0.600
— fir, - - -	0.550
Cork, - - -	0.240

## PNEUMATICS.

PNEUMATICS is the science which treats of the *mechanical* properties of elastic or aeriform fluids ; such as their *weight, density, compressibility, and elasticity*. The other properties of elastic fluids will be treated of under chemistry : a knowledge of that science being necessary in order to understand them.

The air is a fluid in which we live and breathe : it entirely envelopes our globe, and extends to a considerable height around it. Together with the clouds and vapours that float in it, it is called the *atmosphere*. As it is possessed of gravity, in common with all other fluids, it must press upon bodies in proportion to the depth at which they are immersed in it ; and it also presses in every direction, in common with other fluids.

It differs from other fluids in the four following particulars : 1. It can be compressed into a much less space than what it naturally possesses ; 2. It is of an elastic nature, by which it returns to its former volume when the pressure is removed, the force of its spring being equal to its weight ; 3. It is of a different degree of density in every part upwards from the earth's surface, decreasing in

its weight, bulk for bulk, the higher it rises ;  
4. It cannot be congealed or fixed as other fluids may.

Few people who are unacquainted with the principles of natural philosophy, suppose that the air, by which we are surrounded, is a material substance, like water, or any other visible matter. Being perfectly invisible, and affording no resistance to the touch, it must seem to them extraordinary, to consider it as a material substance ; and yet a few simple experiments will convince any one that it is really matter, possessing weight, and the power of resisting other bodies that press against it.

Take a bladder that has not the neck tied, and you may press the sides together, and squeeze it into any shape. Fill this bladder with air by blowing into it, and tie a string fast round the neck : you then find that you cannot, without breaking the bladder, press the sides together, and that you can scarcely alter its figure by any pressure. Whence then arise those effects ? when the bladder was empty, you could press it into any form ; but the air with which it is filled prevents this : the resistance you experience, when it is filled with air, proves that that is as much matter as any other substance that we are acquainted with.

We are accustomed to say, that a vessel is empty, when we have poured out of it the water which it contained. Throw a bit of cork upon a bason of water, and having put an empty tumbler over it, with the mouth downwards, force it down through the water ; the cork will show the surface of the water within the tumbler, and you will see that it will not rise so high within as without the glass ; nor, if you press ever so hard, will it rise to the

same level. The water is, therefore, prevented from rising within the tumbler, by some other substance which already occupies the inside; which substance is the air that filled the tumbler when it was inverted, and which could not escape, on account of the superior pressure of the water.

In like manner, having opened a pair of common bellows, stop up the nozzle securely, and you will find that you cannot shut the bellows, which seems to be filled with something that yields a little, like wool; but if you unstop the nozzle, the air will be expelled, and may be felt against the hand.

When the air is at rest, we can move in it with the utmost facility; nor does it offer to us a sensible resistance, except the motion be quick, or the surface opposed to it considerable; but when that is the case, its resistance is very sensible, as may be easily perceived by the motion of a fan.

When air is in motion, it constitutes *wind*, which is nothing more than a current or stream of air, varying in its force, according to the velocity with which it flows.

The invisibility of air, therefore, is only the consequence of its *transparency*; but it is possessed of all the common properties of matter. When a vessel is empty, in the usual way of speaking, it is in fact still filled with air.

But it is possible to empty a vessel, even of the air which it contains, by which means we shall be able to discover several properties of this fluid.

Galileo first discovered, in 1600, that air had weight like other bodies. And his pupil, Torricelli, applied this discovery of the pressure of the atmosphere, to the explanation of the rise of water in pumps, which it had been formerly imagined was owing to

nature's "abhorrence of a vacuum." Torricelli, also, pursuing this idea, by using a column of mercury instead of water, produced what has since been called the *Torricellian vacuum*, for which see the description of the barometer. But from the nature of the apparatus producing this vacuum or space absolutely free from air, it was very difficult to try what effect would be produced on various bodies placed in it. In 1654, Otto von Guericke, of Magdeburgh, invented the air pump, and made numerous experiments with it. His air pump, however, was of a very clumsy construction, being obliged to place the vessels under water, in order to be exhausted. Boyle, assisted by Hooke, contrived the present pump with two barrels, and the vacuum so made has been frequently called the *Boylean vacuum*, in contradistinction to the *Torricellian*.

As it is by means of the air pump that all the mechanical properties of air are demonstrated, it will be necessary to describe its construction, and the manner of using it.

Plate 6. fig. 1. is the air pump that is most in use. A A are two brass barrels, each containing a piston or short cylinder of metal, that fits the inside exactly. A hole passes through this piston which is covered by a flap or valve that can only open upwards. The pistons are made to move up and down alternately in the barrel, by means of the winch B, which has a pinion that fits into the teeth of the racks C C, which are made upon the ends of the pistons.

On the square wooden frame D E, there is placed a brass plate G, ground perfectly flat, and also a brass tube let into the wood communicating with the two cylinders and the cock I, and open-

ing into the centre of the brass plate at *a*. The glass vessel *K*, to be emptied or exhausted of air, has its rim ground quite flat, and rubbed with a little pomatum, or lard, to make it fit more closely upon the brass plate of the pump. These vessels are called *receivers*. Having shut the cock *I*, the pistons are worked by the winch, and the air escapes by its elasticity when the piston is forced down; but the valve opening upwards, the air is prevented from returning into the vessel; and thus the receiver is gradually exhausted, and will then be fixed fast upon the pump-plate. By opening the cock *I*, the air rushes again into the receiver.

“As light as air,” is a common saying; yet air can be shown to have more weight than is generally supposed. Take a hollow copper ball, or other vessel, which holds a wine quart, having a neck to screw on the plate of the air-pump, and after weighing it when full of air, exhaust it, and weigh it when empty; it will be found to have lost 16 grains, which shows that this is the weight of a quart of air. But a quart of water weighs 14,621 grains: this divided by 16, quotes 914 in round numbers; so that water is 914 times as heavy as air near the surface of the earth. This supposes air at a medium temperature and density: for these, as will be seen afterwards, are variable.

When the receiver is placed upon the plate of the air-pump without exhausting it, it may be removed again with the utmost facility, because there is a mass of air under it, that resists by its elasticity the pressure on the outside; but exhaust the receiver, thus removing the counter pressure, and it will be held down to the plate by the weight of the air upon it.



What the pressure of the air amounts to is exactly determined in the following manner.

When the surface of a fluid is exposed to the air, it is pressed by the weight of the atmosphere equally on every part, and consequently remains at rest. But if the pressure be removed from any particular part, the fluid must yield in that part, and be forced out of its situation.

Into the receiver A (Plate 6. fig. 2.), put a small vessel with quicksilver, or any other fluid, and through the collar of leathers at B, suspend a glass tube, *hermetically sealed*, (that is, closed by the glass blower,) over the small vessel. Having exhausted the receiver, let down the tube into the quicksilver, which will not rise into the tube as long as the receiver continues empty. But re-admit the air, and the quicksilver will immediately ascend. The reason of this is, that upon exhausting the receiver, the tube is likewise emptied of air; and, therefore, when it is immersed in the quicksilver, and the air re-admitted into the receiver, all the surface of the quicksilver is pressed upon by the air, except that portion which lies above the orifice of the tube; consequently, the quicksilver must rise in the tube, and continue so to do, until the weight of the elevated quicksilver press as forcibly on that portion which lies beneath the tube, as the weight of the air does on every other equal portion without the tube.

Take a common syringe of any kind, and having pushed the piston to the farthest end, immerse it into water; then draw up the piston, and the water will follow it. This is owing to the same cause as the last: when the piston is pulled up, the air is drawn out of the syringe with it, and the pressure of the atmosphere is removed from the part of the

water immediately under it; consequently the water is obliged to yield in that part to the pressure on the surface.

It is upon this principle that all those pumps called *sucking-pumps* act: the piston, fitting tightly the inside of the barrel, by being raised up, removes the pressure of the atmosphere from that part, and consequently the water is drawn up by the pressure upon the surface.

These effects, arising from the weight and pressure of the atmosphere, were formerly attributed to *suction*; a word which ought to be exploded, as it conveys a false notion of the cause of these and similar phenomena. To prove that an exhausted receiver is held down by the pressure of the atmosphere, take one open at top, and ground quite flat, as A, (Plate 6. fig. 3.) and covered with a brass plate B, which has a brass rod passing through it, working in a collar of leather, so as to be air-tight: to this rod suspend a small receiver within the large one, a little way from the bottom; place the receiver A upon the pump-plate, and exhaust it: it will now be fixed fast down; but the small receiver may be pulled up or down with perfect ease, as it is itself exhausted, and all the air which surrounded it removed, consequently it cannot be exposed to any pressure; let then the small one down upon the plate, but not over the hole by which the air is extracted, and re-admit the air into the large receiver, which may then be removed; it will be found that the small one being itself exhausted, is held down fast by the air, which is now admitted round the outside. If the large receiver be again put over it and exhausted, the small one will be at liberty, and so on, as often as the experiment is repeated.

This effect cannot be accounted for upon any other principle than the pressure of the air; as the common idea of suction can have nothing to do in the case of the small receiver, which is fixed down merely by letting in the air round it. We ought, therefore, to attribute all those effects which are vulgarly ascribed to suction, such as the raising of water by pumps, &c. to the weight and pressure of the atmosphere.

A square column of quicksilver,  $29\frac{1}{2}$  inches high, and an inch thick, weighs just 15 pounds, consequently, the air presses with a weight equal to 15 pounds upon every square inch of the earth's surface; and 144 times as much, or 2160 pounds upon every square foot.

The earth's surface contains, in round numbers, 200,000,000 square miles; and as every square mile contains 27,876,400 square feet, there must be 5,575,080,000,000,000 square feet on the earth's surface; which number multiplied by 2160 pounds (the pressure on each square foot) gives 12,043,468,800,000,000,000 pounds for the pressure, or whole weight of the atmosphere.

Reckoning the surface of a middle-sized man to be about 14 square feet, he sustains a pressure from the air equal to 30,240 lbs. troy, or 11 tons 2 cwt. and  $18\frac{1}{2}$  lbs. It may be asked, how it happens that we are not sensible of so great a pressure? The reason is, that such pressures only are perceived by us as move our fibres, and put them out of their natural situations. Now the pressure of the air is equal on all parts of the body, and it is balanced by the spring of the air contained in the body; therefore it cannot possibly displace any of the fibres, but on the contrary, braces, and keeps them all in their relative situations.

But if the pressure be removed from any particular part, the pressure on the neighbouring parts immediately becomes sensible. Thus, if we take a receiver open at the top, and cover it with the hand, upon exhausting the receiver, and thereby taking off the pressure from the palm of the hand, we shall feel it pressed down by an immense weight, so as to give pain that would soon be insupportable, and endanger the breaking of the hand.

If the top of the receiver be covered by a piece of flat glass, upon exhausting it, the glass will be broken to pieces by the incumbent weight; and this would happen to the receiver itself, but for the arched top, that resists the weight much more than a flat surface.

This experiment may be varied, by tying a piece of very thin wet bladder over the open mouth of the receiver, and leaving it to dry till it becomes as tight as a drum. Upon exhausting the receiver, you will perceive the bladder rendered concave, and it will yield more and more, until it break with a loud report, which is occasioned by the air striking forcibly against the inside of the receiver, upon being re-admitted.

Air is one of the most elastic bodies in nature; that is, it is easily compressed into less compass, and when the pressure is removed, it immediately regains its former bulk.

Let mercury be poured into a bent tube A B C D (Plate 6. fig. 4.) open at both ends, to a small height, as B C; then stopping the end D with a cork, or otherwise, air-tight, measure the length of confined air D C, and pour mercury into the other leg A B, till the height above the surface of that in C D be equal to the height at which it

stands in the barometer at the time. Then it is plain, that the air in the shorter leg will be compressed with a force twice as great as at first, when it possessed the whole space C D; for then it was compressed only with the weight of the atmosphere, but now it is compressed by that weight and the additional equal weight of a column of mercury. The surface of the mercury will now be at E; and it will be found, upon measuring it, that the space D E, into which the air is now compressed, is just half the former C D. If another column of mercury were added, equal to the former, it would be reduced into one-third of the space it formerly occupied.

Hence *the density of the air is proportional to the force that compresses it.*

As all the parts of the atmosphere gravitate, or press upon each other, it is easy to conceive, that the air next the surface of the earth is more compressed and denser than what it is at some height above it. Thus, if wool were thrown into a deep pit until it reached the top, the wool at the bottom, having all the weight of what was above it, would be squeezed into a less compass; the layer or stratum above it would not be pressed quite so much; the one above that, still less; and so on, till the upper one, having no weight over it, would be in its natural state. This is the case with the air, or atmosphere, that surrounds our earth, and accompanies it in its motion round the sun. On the tops of lofty buildings, but still more on those of mountains, the air is found to be considerably less dense than at the level of the sea.

The height of the atmosphere has never yet been exactly ascertained; indeed, on account of its great elasticity, it may extend to an immense distance,

becoming, however, rarer, in proportion to its distance from the earth.

It is observed, that at a greater height than 45 miles, it does not refract the rays of light from the sun; and this is usually considered as the limit of the atmosphere. In a rarer state, however, it may extend much farther. And this is by some thought to be the case, from the appearance of certain meteors which have been reckoned to be 70 or 80 miles distant, and whose light is thought to depend upon their coming through our atmosphere.

Dr. Cotes has demonstrated that, if altitudes in the air be taken in arithmetical proportion, the rarity of the air will be in geometrical proportion. For instance,

At the altitude of	} Miles above the surface of the earth, the air is	7	.....	4	} times thinner and lighter than at the earth's surface.
		14	.....	16	
		21	.....	64	
		28	.....	256	
		35	.....	1024	
		42	.....	4096	
		49	.....	16384	
		56	.....	65536	
		63	.....	262144	
		70	.....	1048576	
		77	.....	4194304	
		84	.....	16777216	
		91	.....	67108864	
		98	.....	268435456	
		105	.....	1073741824	
112	.....	4294967296			
119	.....	17179869184			
126	.....	68719476736			
133	.....	274877906944			
140	.....	1099511627776			

And hence it is easy to prove by calculation, that a cubic inch of such air as we breathe would be so

much rarefied at the altitude of 500 miles, that it would fill a sphere equal in diameter to the orbit of Saturn.

The *elastic power of the air is always equivalent to the force which compresses it*; for if it were less, it would yield to the pressure, and be more compressed; were it greater, it would not be so much reduced, action and re-action being always equal; so that the elastic force of any small portion of the air we breathe is equal to the weight of the incumbent part of the atmosphere, that weight being the force which confines it to the dimensions it possesses.

To prove this by an experiment, pour some quicksilver into the small bottle A (Plate 6. fig. 5.) and screw the brass collar *c* of the tube B C into the brass neck of the bottle, and the lower end of the tube will be immersed into the quicksilver, so that the air above the quicksilver in the bottle will be confined there. This tube is open at top, and is covered by the receiver G, and large tube E F; which tube is fixed by brass collars to the receiver, and is closed at top. This preparation being made, exhaust the air out of the receiver G, and its tube, by putting it upon the plate of the air-pump, and the air will, by the same means, be exhausted out of the inner tube B C, through its open top at C. As the receiver and tubes are exhausting, the air that is confined in the glass bottle A will press so by its spring, as to raise the quicksilver in the inner tube to the same height as it stands in the barometer.

#### *Miscellaneous Experiments.*

1. Plate 6. fig. 6. represents a little machine, consisting of two mills, *a* and *b*, which are of equal

weights, independent of each other, and which turn equally free on their axles in the frame. Each mill has four thin arms or sails fixed into the axis: those of the mill *a* have their planes at right angles to its axis, and those of *b* have their planes parallel to it. Therefore, as the mill *a* turns round in common air, it suffers little resistance, because its sails cut the air with their thin edges: but the mill *b* suffers much more, because the broad side of its sails move against the air when it turns round. In each axle is a fine pin near the middle of the frame, which goes quite through the axle, and stands out a little on each side of it: under these pins a slider may be made to bear, which will hinder the mills from going when a strong spring is set or bent against the opposite ends of the pins.

Having set this machine upon the pump-plate, draw up the slider to the pins on one side, and set the spring at bend on the opposite ends of the pins: then push down the slider, and the spring acting equally strong upon each mill, will set them both going with equal forces and velocities; but the mill *a* will run much longer than the mill *b*, because the air makes much less resistance against the edges of its sails than against the sides of the sails of *b*.

Draw up the slider again, and set the spring upon the pins as before; then cover the machine with the receiver upon the pump-plate; and having exhausted the receiver of air, push down the wire through the collar of leathers in the neck upon the slider; which will disengage it from the pins, and allow the mills to turn round by the impulse of the spring: as there is no air in the receiver to make any sensible resistance against them, they will both move a considerable time longer than



they did in the open air; and the moment that one stops, the other will do the same. This shows that air resists bodies in motion, and that equal bodies meet with different degrees of resistance, according as they present greater or less surfaces to the air.

2. Take a tall receiver A (Fig. 7.), covered at top by a brass plate, through which works a rod in a collar of leathers, and to the bottom of which there is a particular contrivance for supporting a guinea and a feather, and for letting them drop at the same instant. If they are let fall while the receiver is full of air, the guinea will fall much quicker than the feather; but if the receiver be first exhausted, it will be found that they both arrive at the bottom at the same instant, which proves that all bodies would fall to the ground with the same velocity, if it were not for the resistance of the air, which impedes most the motion of those bodies that have the least momentum. In this experiment the observers ought not to look at the top, but at the bottom of the receiver, otherwise, on account of the quickness of their motion, they will not be able to see whether the guinea and feather fall at the same instant.

3. Take a receiver, having a brass cap fitted to the top with a hole in it; fit one end of a dry hazel branch about an inch long tight into the hole, and the other end tight into a hole quite through the bottom of a small wooden cup; then pour some quicksilver into the cup, and exhaust the receiver of air; the pressure of the outward air on the surface of the quicksilver will force it through the pores of the hazel, from whence it will descend in a beautiful shower into a glass cup placed under the receiver to catch it.

4. Put a wire through the collar of leathers on the top of the receiver, and fix a bit of dry wood on the end of the wire within the receiver; then exhaust the air, and push the wire down, so as to immerse the wood into a jar of quicksilver on the pump-plate; this done, let in the air; upon taking the wood out of the jar, and splitting it, its pores will be found full of quicksilver, which the force of the air drove into the wood.

5. Join together the two brass hemispherical cups A and B (Fig. 8.) with a wet leather between them, having a hole in the middle of it; then having screwed off the handle at C, screw both the hemispheres put together into the pump-plate, and turn the cock E, so that the pipe may be open all the way into the cavity of the hemispheres; then exhaust the air out of them, and turn the cock; unscrew the hemispheres from the pump, and having put on the handle C, let two strong men try to pull the hemispheres asunder by the rings; this they will find hard to do; for if the diameter of the hemispheres be four inches, they will be pressed together by the external air with a force equal to 190 pounds; and to show that it is the pressure of the air that keeps them together, hang them by either of the rings upon the hook of the wire in the receiver A (Fig. 3.), and, upon exhausting the air out of the receiver, they will fall asunder of themselves.

6. Screw the end A of the brass pipe A B (Fig. 9.) into the pump-plate, and turn the cock *e* until the pipe be open; then put a wet leather on the plate *c d* fixed on the pipe, and cover it with the tall receiver G H, which is close at top; then exhaust the air out of the receiver, and turn the cock *e* to keep it up; which done, unscrew the

pipe from the pump, and set its end *A* into a basin of water, and turn the cock *e* to open the pipe; on which, as there is no air in the receiver, the pressure of the atmosphere on the water in the basin will drive the water forcibly through the pipe, and make it play up in a jet to the top of the receiver.

7. Set a square phial upon the pump-plate, and having covered it with a wire cage, put a close receiver over it, and exhaust the air out of the receiver; at the same time, the air will also make its way out of the phial, through a small valve in its neck. When the air is exhausted, turn the cock below the plate to re-admit the air into the receiver; and as it cannot get into the phial again, because of the valve, the phial will be broken into pieces by the pressure of the air upon it. Had the phial been of a round form, it would have sustained this pressure like an arch, without breaking; but as its sides are flat, it cannot.

8. To show the elasticity or spring of the air: tie up a very small quantity of air in a bladder, and put it under the receiver; then exhaust the air out of the receiver; and the air which is confined in the bladder (having nothing to act against it) will expand by the force of its spring, so as to fill the bladder completely: but upon letting the air into the receiver again, it will overpower that in the bladder, and press its sides close together.

9. If the bladder so tied up be put into a wooden box, and have 20 or 30 pounds weight of lead placed upon it, and the box be covered with a close receiver; upon exhausting the air out of the receiver, that which is confined in the bladder will expand itself so as to raise up all the lead by the force of its spring.

10. Screw the pipe A B (Fig. 9.) into the pump-plate, place the tall receiver G H upon the plate *e d*, as before, and exhaust the air out of the receiver; then turn the cock *e* to keep out the air, unscrew the pipe from the pump, and screw it into the mouth of the copper vessel C (Fig. 10.), the vessel having been first about half filled with water. Then open the cock *e*, and the spring of the air which is confined in the copper vessel will force the water up through the pipe A B in a jet into the exhausted receiver, as strongly as it did by its pressure on the surface of the water.

11. If a rat, mouse, or bird, be put under a receiver, and the air exhausted, the animal will be at first oppressed as with a great weight, then grow convulsed, and at last expire in agonies. But as this experiment is too shocking to most spectators, it is common to substitute a machine called the *lungs glass* in place of the animal.

12. If a butterfly be suspended in a receiver, by a fine thread tied to one of its horns, it will fly about in the receiver as long as it continues full of air; but if the air be exhausted, though the animal will not die, and will continue to flutter its wings, it cannot remove itself from the place where it hangs in the middle of the receiver, until the air be let in again, and then the animal will fly about as before.

13. Put a cork into a square phial, and fix it in with wax or cement; put the phial on the pump plate with the wire cage, and cover it with a close receiver; then exhaust the air out of the receiver, and the air that was corked up in the phial will break it outwards by the force of its spring, because there is no air left on the outside of the phial to act against that within it.

14. Put a shrivelled apple under a close receiver, and exhaust the air; then the spring of the air within the apple will plump it out so as to cause all the wrinkles to disappear; but upon letting the air into the receiver again, to press upon the apple, it will return to its former decayed and shrivelled state.

15. Take a fresh egg, and cut off a little of the shell and film from its smallest end; then put the egg under a receiver, and pump out the air; all the contents of the egg will be forced out into the receiver, by the expansion of a small bubble of air contained in the great end, between the shell and film.

16. Put some warm beer into a glass, and having set it on the pump, cover it with a close receiver, and then exhaust the air. Whilst this is doing, and thereby the pressure more and more taken off from the beer in the glass, the air therein will expand itself, and rise up in innumerable bubbles to the surface of the beer; and thence it will be taken away with the other air in the receiver. When the receiver is nearly exhausted, the air in the beer, which could not disentangle itself quick enough to get off with the rest, will now expand itself so as to cause the beer to have all the appearance of boiling; and the greatest part of it will go over the glass.

17. Put some water into a glass, and a bit of dry wainscot or other wood into the water; then cover the glass with a close receiver, and exhaust the air; the air in the wood having liberty to expand itself, will come out plentifully, and make all the water to bubble, especially about the ends of the wood, because the pores lie lengthwise. A cubic inch of dry wainscot has so much air in it,

that it will continue bubbling for near half an hour together.

18. Let a large piece of cork be suspended by a thread at one end of a balance, and counterpoised by a leaden weight, suspended in the same manner, at the other. Let this balance be hung to the inside of the top of a large receiver; which being set on the pump, and the air exhausted, the cork will preponderate, and show itself to be heavier than the lead; but upon letting in the air again, the equilibrium will be restored. The reason of this is, that, since the air is a fluid, and all bodies lose as much of their absolute weight in it as is equal to the weight of their bulk of the fluid, the cork being the larger body, loses more of its real weight than the lead does; and, therefore, must in fact be heavier, to balance it under the disadvantage of losing some of its weight, which disadvantage being taken off by removing the air, the bodies then gravitate according to their real quantities of matter, and the cork which balanced the lead in air shows itself to be heavier when in vacuo.

19. Set a lighted candle upon the pump, and cover it with a tall receiver. If the receiver holds a gallon, the candle will burn a minute; and, then, after having gradually decayed from the first instant, it will go out; which shows that a constant supply of fresh air is as necessary to feed flame as animal life.

20. The moment when the candle goes out, the smoke will be seen to ascend to the top of the receiver, and there it will form a sort of cloud; but upon exhausting the air, the smoke will fall down to the bottom of the receiver, and leave it as clear at the top as it was before it was set upon the

pump. This shows that smoke does not ascend on account of its being positively light, or having no weight, but because it is lighter than air; and its falling to the bottom when the air is taken away shows that it is not destitute of weight. So most sorts of wood ascend or swim in water; yet we all know that wood has gravity or weight.

21. Set a receiver which is open at top on the air-pump, and cover it with a brass-plate and wet leather, and having exhausted it of air, let the air in again at top through an iron pipe, making it pass through a charcoal flame at the end of the pipe; and when the receiver is full of that air, lift up the cover, and let down a mouse or bird into the receiver, and the burnt air will immediately kill it. If a candle be let down into that air, it will go out directly; but by letting it down gently, it will drive out the impure air, and good air will get in.

22. Set a bell on the pump-plate, having a contrivance so as to ring it at pleasure, and cover it with a receiver; then make the clapper strike against the bell, and the sound will be very well heard; but exhaust the receiver of air, and then, if the clapper be made to strike ever so hard against the bell, it will make no sound; which shows that air is absolutely necessary for the propagation of sound.

#### OF CONDENSED AIR.

It has been shown, that air can be *rarefied*, or made to expand: we now proceed to show that it can also be *condensed*, or pressed into less space than what it generally occupies. The instrument used for this purpose is called a *condenser*.

Plate 6. fig. 12. represents a machine of this kind; it consists of a brass-barrel containing a piston, with a valve opening downwards; so that, as the piston is raised, the air passes through the valve; but as the piston is pushed down, the air cannot return, and, is therefore, forced through a valve at the bottom of the barrel that allows it to pass through into the receiver B, but prevents it from returning. Thus, at every stroke of the piston, more air is thrown into the receiver, which is of very thick and strong glass. The receiver is held down upon the plate C by the cross-piece D, and the screws E F. The air is let out of the receiver by the cock G, which communicates with it.

A great variety of experiments may be performed by means of condensed air.

1. The sound of a bell is much louder in condensed than in common air.

2. A square phial may be broken by condensing the air round it, provided the condensed air be prevented from getting within the phial.

3. A very beautiful fountain may be made by condensed air. Procure a strong copper vessel (Plate 7. fig. 1.) having a tube that screws into the neck of it, so as to be air-tight, and long enough to reach near to the bottom. Having poured a quantity of water into the vessel, but not enough to fill it, and screwed in the tube, adapt to it a condensing syringe, and condense the air in the vessel; shut the stop-cock, and unscrew the syringe; then, on opening the stop-cock, the air acting upon the water in the vessel will force it out into a jet of great height. A number of different kinds of jet pieces may be screwed on the



tube, so as to cause the water to exhibit the appearance of stars, wheels, &c.

### THE BAROMETER.

This is an instrument for measuring the pressure of the air. It was invented by Torricelli, in the following manner.—Having suspected that the pressure of the atmosphere was the cause of the ascent of water in pumps, and supposing that mercury, being fourteen times as heavy as water, the air could only support a column of mercury  $\frac{1}{14}$  part of the height of one of water, he took a glass tube four feet long, and closed at one end: this he filled with mercury, and kept his finger tight on the open end; then, inverting the tube, he immersed the open end, with his finger still in it, under the surface of the mercury. As he expected, the mercury subsided in the tube so as to stand only about  $27\frac{1}{2}$  above the surface of the basin, or equal to  $\frac{1}{14}$  of the height of water in pumps. He therefore inferred, that the water and the mercury were kept up by the same cause, and that the difference between the heights of the two columns was owing to the difference of the specific gravities of the substances.

It was afterwards observed, that the height at which the mercury stood in this tube was not constant, and, consequently, that the pressure of the atmosphere was variable; and also that this change of height was connected with alterations in the weather.

The simplest and most common construction of the barometer is shown, Plate 7. fig. 2. It consists of a glass-tube, secured from injury by being fixed to a wooden frame; the tube is closed by being

hermetically sealed at the top, and the lower end is open, and placed in a small basin of mercury. The scale at the upper part, which is also shown more at large at Fig. 3., indicates the parts of inches which the mercury rises or falls; and a slider of metal, which can be placed to the exact line of the surface of the mercury, enables one to observe how much it has varied since the last observation.

In this construction, as the space through which the upper surface of the mercury in the tube has to rise or fall, does not exceed 4 inches at most, that is, from about 27 inches to about 31 inches above the mercury in the basin, several contrivances have been used to increase the scale, and thereby show more sensibly small changes. The chief of these are as follow.

The *diagonal barometer*, A B C (Fig. 4.), is a tube sealed at C, immersed in mercury at A; this tube is perpendicular from A to B; where the scale of variation begins at B, it is bent, as C B. The part B C proceeds to the highest limit in the scale of variation, I C; consequently, while the mercury rises from I to C in the common barometer, it will move in this from B to C; and so the scale will be, by this means, enlarged in the proportion of B C to I C.

However, this form being subject to a great degree of friction, on account of the obliquity in the part B C, which inclination makes the quicksilver frequently divide into several parts, it requires the trouble of filling tubes anew too often.

The *horizontal, or rectangular barometer*, consists of a tube, A C D F (Fig. 5.), sealed on the upper end A, and bent to a right angle at D. The mercury stands in both legs from E to C. Here, it is evident, that in moving three inches from A to C,

it will move through so many times three inches in the small leg D F, as the bore of D F is less than the bore of A C; whence the motion of the mercury at E must be extremely sensible. This form is liable to the same exceptions as Fig. 4.; and, besides a great degree of friction, and the frequent breaking off of the mercury in the leg E, the part D F being a very small bore, the free motion of the mercury therein must be impeded by the attraction of cohesion.

The *wheel barometer*.—A (Fig. 6.) represents the quicksilver in a glass tube, having a large round head or ball, and turned up at bottom B; upon the surface of the mercury, in the recurved leg, there is placed a short glass tube loaded with mercury, with a string going over a pulley, and balanced by another weight hanging freely in the air. As the surface at A is very large, and that at B very small, the motion of the quicksilver, and consequently of the ball A, will at bottom be very considerable; but as the weight moves up and down, it turns the pulley, and that a hand or index; and, by the divisions of a large graduated circle, the minutest variations of the air are plainly shown, if the instrument be accurately made, and the friction of the several parts be inconsiderable.

There is also a barometer, contrived so as not to be affected by the motion of a ship, called the *marine barometer*.

Also a *portable barometer*, for moving from place to place without injury, and for measuring the heights of mountains, by observing the difference of the altitude of the mercury at the bottom and top of the mountain.

A thermometer should always be attached to the barometer, as a necessary appendage; and, by the side of it, a scale of correction, to show how much to add or subtract from the height of the mercury in the barometer for the degree of temperature; for, it is evident that the mercury in the tube will be affected by heat and cold, in the same manner as the thermometer, and, on that account, it will not show the true weight of the atmosphere. This correction is, therefore, very necessary.

Ever since it was observed that a change of weather generally accompanied or followed a variation in the height of the barometer, it has been used as a prognostic of the weather; and hence it is frequently called a *weather-glass*. A great variety of observations have been made by different persons, relative to the effect which certain changes of weather have upon this instrument; and thence they have derived a set of rules, that assist in enabling one to foretel the changes in the weather.

But these are by no means so certain, and so much to be depended upon, as many suppose. So numerous are the causes that affect the state of the atmosphere, with which we are but little acquainted, that no instrument can be implicitly depended upon as foretelling the alterations that are to happen.

The following are the principal circumstances to be observed in using the barometer as a weather-glass.

1. The rising of the mercury presages, in general, fair weather; and its falling, foul weather; as rain, snow, high winds, and storms.
2. In very hot weather, the falling of the mercury foretels

thunder. 3. In winter, the rising presages frost; and, in frosty weather, if the mercury fall three or four divisions, there will probably follow a thaw; but in a continued frost, if the mercury rise, it will most likely snow. 4. When foul weather happens soon after the falling of the mercury, expect but little of it; and, on the contrary, expect but little fair weather, when it proves fair shortly after the mercury has risen. 5. In foul weather, when the mercury rises much and high, and so continues for two or three days before the foul weather is quite over, then expect a continuance of fair weather to follow. 6. In fair weather, when the mercury falls much and low, and thus continues for two or three days before the rain comes, then expect a great deal of wet, and probably high winds. 7. The unsettled motion of the mercury denotes uncertain and changeable weather. 8. You are not so strictly to observe the words engraved on the plates (though in general it will agree with them) as the mercury's rising and falling; for if it stand at *much rain*, and then rise up to *changeable*, it presages fair weather, though not to continue so long as if the mercury had risen higher; and so, on the contrary; if the mercury stood at *fair*, and fall to *changeable*, it presages foul weather; though not so much of it as if it had sunk lower.

From these observations, it appears that it is not so much the height of the mercury in the tube that indicates the state of weather, as the motion of it up and down.

Besides the barometer, there are several other instruments used for meteorological purposes; such as the *thermometer*, *hygrometer*, *wind-gage*, *rain-gage*, and *electrometer*.

The *hygrometer* is an instrument for measuring the degree of dryness, or dampness, of the atmosphere. They are of various constructions. One of the most sensible is that made of the beard of wild oats, which, by twisting, moves an index fastened to it. Another kind is formed of a thin slip of whalebone, which lengthens in moist, and contracts in dry weather.

The *wind-gage* (called also *aremoscope*) is an instrument for measuring the force of wind; and the *rain-gage* ascertains the quantity of rain that falls on each square foot of the earth's surface.

Plate 7. fig. 9. represents one of the best constructions of rain-gages. It consists of a hollow cylinder, having within it a cork-ball attached to a wooden stem, which passes through a small opening at the top, on which is placed a large funnel. When this instrument is placed in the open air in a free place, the rain that falls within the circumference of the funnel will run down into the tube, and cause the cork to float; and the quantity of water in the tube may be seen by the height to which the stem of the float is raised. The stem of the float is so graduated, as to show, by its divisions, the number of perpendicular inches of water which fell on the surface of the earth since the last observation. It is hardly necessary to observe, that after every observation the cylinder must be emptied.

The *electrometer* will be described under electricity.

#### PRACTICAL DIRECTIONS FOR USING THE AIR PUMP.

The invention and general construction of the air-pump have been already described, p. 129.; but

some circumstances respecting it could not be understood before the barometer was explained.

The gage, or instrument for measuring the degree of rarefaction or exhaustion produced in the receiver, is a necessary appendage to the air-pump. If a barometer be included beneath the receiver, the mercury will stand at the same height as in the open air; but when the receiver begins to be exhausted, the mercury will descend, and rest at a height which is, in its proportion to its former height, as the spring of the air remaining in the receiver is to its spring before exhaustion. Thus, if the height of the mercury, after exhaustion, is the thousandth part of what it was before, we say that the air in the receiver is rarefied 1000 times. On account of the inconvenience of including a barometer in a receiver, a tube of six or eight inches in length is filled with mercury, and inverted in the same manner as the barometer. This being included, answers the same purpose, with no other difference, than that the mercury does not begin to ascend till about three-fourths of the air is exhausted: it is called the *short barometer gage*. It is generally placed detached, but communicating with the receiver by a tube concealed in the frame, as is represented at Plate 6. fig. 1. Others place a tube of a greater length than the barometer, with its lower end in a vessel of mercury, exposed to the pressure of the air, while its upper end communicates with the receiver. Here the mercury rises as the exhaustion proceeds; and the pressure of the remaining air is shown by the difference between its height and that of a barometer in the room: this is called the *long barometer gage*.

In using the air-pump, every substance containing moisture should be removed from the pump-plate, as water assumes the form of an elastic vapour when the pressure of the atmosphere is taken away. The receivers used formerly to be placed upon the pump-plate, on leathers soaked in water or oil; but Mr. Nairne discovered that an elastic vapour arose from this that considerably affected the gage, and prevented it from showing the degree of rarefaction of the air. Instead of placing leathers under the receivers, the best way is, to have the pump-plate ground perfectly flat, as also the edge of the receiver, which should be rubbed with a little hog's lard or soft pomatum; this will perfectly exclude the air, without affording any moisture. The pump-plate and the receiver should be wiped very clean.

When leathers are used, the barometer-gages will not show the degree of rarefaction of the air; which, however, may be ascertained by a gage invented by Mr. Smeaton, and called, from its form, the *pear-gage*. It consists of a glass vessel, in the form of a pear (Plate 6. fig. 11.), and sufficient to hold about half a pound of mercury: it is open at one end, and at the other end is a tube hermetically closed at top. The tube is graduated, so as to represent proportionate parts of the whole capacity. This gage, during the exhaustion of the receiver, is suspended in it by a slip wire, over a cistern of mercury, placed also in the receiver. When the pump is worked as much as is thought necessary, the gage is let down into the mercury, and the air re-admitted. The mercury will immediately rise in the gage; but if any air remained in the receiver, a certain portion of it would be in the



gage; and as it would occupy the top of the tube above the mercury, it would show, by its size, the degree of exhaustion: for the bubble of air would be to the whole contents of the gage, as the quantity of air in the exhausted receiver would to an equal volume of the common atmospheric air. If the receiver contained any elastic vapour generated during the rarefaction, it would be condensed upon the re-admission of the atmospheric air, as it cannot subsist in the usual pressure. The pear-gage, therefore, shows the true quantity of atmospheric air left in the receiver. Hence, it will sometimes indicate that all the permanent air is exhausted from the receiver, except about  $\frac{1}{100000}$  part, when the other gages do not show a degree of exhaustion of more than 200 times, and sometimes much less.

Particular care should be taken, after making any experiments where vapour has been generated, to clear the pump of it, before any other experiments are attempted; for the vapour remains not only in the receiver, but also in the tubes and barrels of the pump, and will, when the air is again rarefied, expand as before. To clear the pump of this vapour, take a large receiver, and, wiping it very dry, exhaust it as far as possible. The expansible vapour which remained in the barrels and the pipes will now be diffused through the receiver, and, consequently, will be as much rarer than it was before as the aggregate capacity of the receiver is larger than that of the pump and pipes. If the receiver be large, one exhaustion will be sufficient to clear the pump so far, that what remains can be of no consequence. If the receiver be small, the operation should be repeated two or three times.

In all mercurial experiments with the air-pump, a short pipe must be screwed into the hole of the pump-plate, so as to raise above it about half an inch, to prevent the quicksilver from getting into the air-pipe and barrels, in case any should accidentally be spilt over the jar; for if it gets into the barrels, it spoils them, by loosening the solder, and corroding the brass.

With respect to the leathers, if the pump-plate is not ground, they are absolutely necessary; they should be previously soaked in oil, from which the moisture has been expelled by boiling, or hog's-lard, with a little bees-wax, which gives a clamminess very proper for the purpose.

It is evident, that the vacuum in the receiver of the air-pump can never be perfect, that is, the air can never be entirely exhausted; for it is the spring of the air in the receiver that raises the valve, and forces its way into the barrel; and the barrel at each suction can only take away a certain part of the remaining air, which is in proportion to the quantity before the stroke as the capacity of the barrel is to that of the barrel and receiver added together.

This, however, is an imperfection that is seldom of much consequence in practice; because most air-pumps, at a certain period of the exhaustion, cease to act, on account of their imperfect construction; for the valves usually consist of a piece of oiled bladder, tied over a hole; so that the air is at liberty to pass by lifting up the bladder, but cannot return again: and thus there will unavoidably be a small space left between the lower valve and the piston, when down.

Now, it will happen, when the air in the receiver is very rare, that its spring will not be

strong enough to overcome the adhesion of the bladder forming the lower valve ; which, consequently, will remain shut, and the exhaustion cannot proceed. Or, before this period, it may happen, that the air between the valves when the piston is up, may be so small as to lie in the space between the two valves when the piston is down, without being sufficiently condensed for its spring to overcome the adhesion of the bladder forming the upper valve, and the weight of the atmosphere that presses it : in this case, the upper valve will remain shut, and the exhaustion cannot proceed.

Various modern improvements in the air-pump obviate these inconveniences in a great degree. Mr. Smeaton enlarged the size of the lower valve ; and, to strengthen it, supported it on a brass grating, resembling a honeycomb. This allowed the valve to rise more easily. He also covered the top of the barrel, making the piston-rod work through a collar of leathers ; by which he took off the pressure of the atmosphere from the piston-valve, which acted against the rarefied air in the receiver. Pumps on this construction have been made by Nairne, and other instrument-makers, and have answered extremely well.

It would not come within the limits of this work to enumerate all the improvements, and different modes of construction, used in this instrument. The latest are the air-pumps, made by Haas and Hurter, Cuthbertson, and Prince ; each of which has particular advantages.

#### THE AIR GUN.

This pneumatical instrument is an ingenious contrivance, which will drive a bullet with great

violence by means of condensed air. Plate 7. fig. 8. represents an iron condenser, for condensing air into the hollow ball *b*: at the end *a* of the condenser there is a male screw, on which the ball is screwed. In the inside of this ball is a valve, to hinder the air, after it is injected, from making its escape, until it be forced open by a pin, against which the hammer of the lock strikes; which then lets out as much air as will drive a ball with considerable force to a great distance.

When you condense the air in the ball, place your feet on the iron cross *h h*, to which the piston-rod *d* is fixed; then lift up the barrel *e a*, by the handles *i i*, until the end of the piston is brought between *e* and *c*; the barrel *a c* will then be filled with air through the hole *e*. Then thrust down the barrel *a c* by the handles *i i*, until the piston *e* join with the neck of the iron ball at *a*. The air being thus condensed between *e* and *a*, will force open the valve in the ball; and when the handles *i i* are lifted up again, the valve will close, and keep in the air: so, by rapidly continuing the stroke up and down, the ball will be filled; after which, unscrew the ball off the condenser, and screw it upon another male screw, which is connected with the barrel, and goes through the stock of the gun, as represented Fig. 7. Twelve dwts. of air have been injected into a ball 3.75 inches diameter, which has discharged 15 bullets with considerable force.

There are many varieties of air-guns: some have a small barrel contained within a large one; and the space between the two barrels serves for the reception of condensed air. In this sort, a valve is fixed at *a* (Fig. 7.), with a condenser fixed to the barrel, and continued through the butt-

end to *c*, where the piston-rod may be always left in. Place your feet on the pin, and the whole gun serves instead of the handles *i i* (Fig. 8.) to condense the air in the barrel.

The *magazine air-gun* differs from the common one, only by having a serpentine-barrel, which contains 10 or 12 balls; these are brought into the shooting barrel successively, by means of a lever; and they may be discharged so fast as to be nearly of the same use as so many different guns.

#### THE DIVING BELL.

To illustrate the principle of this machine, take a glass-tumbler, and plunge it into water with the mouth downwards; you will find that very little water will rise into the tumbler; which will be very evident, if you lay a piece of cork upon the surface of the water, and put the tumbler over it; for you will see, that though the cork should be carried far below the surface of the water, yet that its upper side is not wetted; the air which was in the tumbler having prevented the entrance of the water; but as air is compressible, it could not entirely exclude the water, which, by its pressure, condensed the air a little.

The first diving-bell of any note was that made by Dr. Halley. It was in the form of a great bell, and was coated with lead, so as to sink empty; weights being distributed about the lower part, to keep it in an inverted position. It was three feet wide at top, five feet wide at bottom, and eight feet high. In the top was fixed a strong clear glass, to let in the light from above, and likewise a cock, to let out the hot air that had been deprived of its vital principle by repeated breathing. It was suspended from the mast of a ship, in such a

manner as to be let down over its side without any danger. Within, there was a circular seat for the divers. To supply the bell with air under water, two barrels, of about 63 gallons each, were made, and cased with lead sufficient to make them sink when empty; each having a hole in its lower part to let in the water, as the air in them is condensed in their descent, and to let it out again when they were drawn up full from below. And, to a hole in the top of the barrels, was fixed a hose, or hollow pipe, well prepared with bees-wax and oil; which was long enough to fall below the hole at the bottom, being sunk with a weight appended: so that the air in the upper part of the barrels could not escape, unless the lower end of these pipes were first lifted up. These air-barrels were fitted with tackle proper to make them rise and fall alternately, like two buckets in a well: in their descent, they were directed, by lines fastened to the under edge of the bell, to the man standing on the stage to receive them; who, by taking up the ends of the pipes above the surface of the water in the bell, gave occasion for the water in the barrels to force all the air in the upper parts into the bell, while it entered below, and filled the barrels. And, as soon as one was discharged, by a signal given it was drawn up; and the other descended, to be ready for use. As the cold air rushed into the bell from the barrel below, it expelled the hot air (which was lighter) through the cock at the top, which was then opened for that purpose. By this method, air was communicated so quick, and in such plenty, that the Doctor tells us, he himself was one of five who were together at the bottom, in nine or ten fathoms water, for above an hour and a half at a time, without experiencing any ill

effects; and that he might have continued there as long as he pleased.

By the glass above, so much light was transmitted when the sun shone, and the sea was clear and even, that he could see perfectly well to read and write, and to take up any thing that was under the bell; and by the return of the air-barrels, he could send up orders, written with an iron pen, on small pieces of lead, when he wished to be moved from place to place. But in misty weather, or when the sea was rough, it was nearly dark in the bell, and he was then obliged to burn a candle, which consumed about as much air as one person.

The only inconvenience which the divers felt was, that upon their going down they felt a pain in their ears, as if the end of a quill was thrust into them, which was owing to the condensed air pressing upon the tympanum. This, however, in a short time ceased.

Doctor Halley also contrived a method of sending a man out of the bell, to some distance, by means of a small bell on his head, with a glass in front, and a pipe communicating with the great bell, to supply him with air.

Mr. Triewald invented a diving-bell of a different form, which was much smaller and less expensive than Dr. Halley's; it only covered half the body of the diver, who stood upon a ring hanging from the bell by chains. There was also a spiral pipe within the bell, by which he could always breathe the air immediately at the surface of the water in the bell, which was cooler and fresher than that at the upper part of the machine.

Mr. Smeaton's diving-bell was a square chest of cast-iron,  $4\frac{1}{2}$  feet in height,  $4\frac{1}{2}$  feet in length, and three feet wide, and afforded room for two men to

work in it. It was supplied with fresh air by a forcing pump. This was used with great success at Ramsgate. Other contrivances have been used for diving to small depths, which have answered very well, such as strong cases for the body, to keep off the pressure of the water, which were supplied with fresh air by pipes from the surface. A very good one of this kind is particularly described in the Philosophical Magazine, vol. viii. p. 59.

#### OF AIR BALLOONS.

The air-balloon is a machine, consisting of a bag filled with air, so light, that it, together with the bag, forms a mass which is specifically lighter than the common air of the atmosphere. A cubic foot of common air is found to weigh above 554 grains, and to be expanded by every degree of heat marked on Fahrenheit's thermometers, about 1-50th part of the whole. By heating a quantity of air, therefore, to 200 degrees Fahr., you will just double its bulk, when the thermometer stands at 54 in the open air, and in the same proportion you will diminish its weight; and if such a quantity of this hot air be inclosed in a bag, that the excess of the weight of an equal bulk of common air, weighs more than the bag with the air contained in it, both the bag and the air will rise into the atmosphere, and continue to do so till they arrive at a place where the external air is naturally so much rarefied, that the weight becomes equal, and here the whole will float.

The power by which hot air is impelled upwards, may be shown by the following experiment. Roll up a sheet of paper in a conical form, and by thrusting a pin into it near the apex, prevent it from unrolling. Fasten it then by its apex, under



one of the scales of a balance, by means of a thread; and having properly counterpoised it by weights put into the opposite scale, apply the flame of a candle underneath, and you will instantly see the cone rise; and it will not be brought into equilibrium with the other, but by a much greater weight than those who have never seen the experiment would believe.

If the magnitude of a balloon be increased, its power of ascension, or the difference between the weight of the included air and an equal bulk of common air, will be augmented in the same proportion. For its thickness being supposed the same, it is as the surface it covers, or only as the square of the diameter. This is the reason why balloons cannot be made to ascend, if under a given magnitude, when composed of cloth, or materials of the same thickness.

In the year 1766, Mr. Cavendish ascertained the weight and other properties of inflammable air, determining it to be at least seven times lighter than common air. Soon after which it occurred to Dr. Black, that, perhaps, a thin bag, filled with inflammable air, might be buoyed up by the common atmosphere, and he thought of having the allantois of a calf prepared for this purpose; but his other avocations prevented him from prosecuting the experiment. The same thought occurred, some years after, to Mr. Cavallo, and he has the honour of being the first who made experiments on the subject. He first tried bladders, but the thinnest of these, however, well scraped and prepared, were found too heavy; he then tried Chinese paper, but that proved so permeable, that the inflammable air passed through it like water through a sieve. His experiments, therefore, made

in the year 1782, proceeded no farther than blowing up soap-bubbles with inflammable air, which ascended rapidly to the ceiling, and broke against it.

But while the discovery of the art of aerostation seemed thus on the point of being made in Britain, it was all at once announced in France, and that from a quarter whence nothing of the kind was to have been expected. Two brothers, Stephen and John Montgolfier, natives of Annonay, and proprietors of a considerable paper manufactory there, had turned their thoughts towards this project, as early as the middle of the year 1782. The idea was first suggested by the natural ascent of the smoke and clouds in the atmosphere, and their design was to form an artificial cloud, by inclosing the smoke in a bag, and making it carry up the covering along with it.

Towards the middle of November that year, the experiment was made at Avignon, with a fine silk bag. By applying burning paper to an aperture at the bottom of it, the air was rarefied, and the bag swelled, and ascended to the ceiling. On repeating the experiment in the open air, it rose to the height of about seventy feet.

Soon after this, one of the brothers arrived at Paris, where he was invited by the Academy of Sciences to repeat his experiments at their expence. In consequence of this invitation, he constructed, in a garden in the Fauxbourg Saint Germain, a large balloon of an elliptical form. In a preliminary experiment, this machine lifted up from the ground eight persons who held it, and would have carried them all off, if more had not quickly gone to their assistance. Next day the experiment was repeated in the presence of the members of the academy;

the machine was filled by the combustion of fifty pounds of straw, made up in small bundles, upon which twelve pounds of chopped wool were thrown at intervals. The usual success attended this exhibition; the machine soon swelled, endeavoured to ascend, and sustained itself in the air, together with a weight of between four and five hundred pounds. It was evident that it would have ascended to a very great height, but as it was designed to repeat the experiment before the king and royal family at Versailles, the cords by which it was tied down were not cut. In consequence of a violent wind and rain, which happened at this time, the machine was so far damaged, that it became necessary to prepare a new one for the time that it had been determined to honour the experiment with the royal presence; and such expedition was used, that this vast machine, of near 60 feet in height, and forty-three in diameter, was made, painted with water-colours both within and without, and finally decorated, in no more than four days and four nights.

Along with this machine was sent a wicker cage, containing a sheep, a cock, and a duck, which were the first animals ever sent up in the atmosphere. The complete success of this experiment was prevented by a violent gust of wind, which tore the cloth in two places near the top, before it ascended; however, it rose to the height of 1440 feet; and after remaining in the air about eight minutes, fell to the ground, at the distance of 10,200 feet from the place of its setting out. The animals were not in the least hurt. The great power of these aerostatic machines, and their very gradual descent to the ground, had originally shown that they were capable of transporting people through the air with

all imaginable safety; and this was further confirmed by the experiment already mentioned. As Mr. Montgolfier, therefore, proposed to make a new aerostatic machine, of a firmer and better construction than the former, M. Pilaire de Rozier (whose temerity in a subsequent experiment proved fatal to him,) offered himself to be the first aerial adventurer. On the 15th of October, 1783, he rose from the garden of the Fauxbourg Saint Antoine, at Paris, in a wicker gallery, about three feet broad, attached to an oval balloon, of 74 feet by 40, which had been made by Montgolfier, and which also carried up a grate, for the purpose of continuing at pleasure the inflation of the balloon, by a fire of straw and wool. The weight of this machine was 1,600 pounds. On that day it was permitted to rise no higher than 84 feet; but on the 19th, when M. Giraud de Vilette ascended with him, they rose to the height of 332 feet, being prevented from farther ascent only by ropes. Encouraged by the success of these experiments, M. Rozier and the Marquis D'Arlandes first trusted a balloon to the elements; and after rising to the height of 3,000 feet, they descended about five miles from the place of their ascent. They experienced great danger on this occasion, from the balloon taking fire, which, however, they extinguished with a wet sponge.

These balloons raised by fire have, however, not been much used, having given place to the other kind, filled with inflammable air, which, by reason of its smaller specific gravity, is safer and more manageable, and is capable of performing voyages of greater length, as it does not require to be supplied with fuel, like the others.

About this time, Count Zambecari sent up from the Artillery-Ground, London, a small gilt balloon, filled with inflammable air, which, in two hours and half, reached a spot near Petworth, in Sussex, and would not then have fallen had it not burst.

The first aerial voyage with an inflammable air balloon, was made by Messrs. Charles and Roberts, from Paris, December 1, 1783.

The machine used on this occasion was formed of silk, covered over with a varnish made of elastic gum, of a spherical figure, and measuring  $27\frac{1}{2}$  feet in diameter.

Having ascended to the height of about one-third part of a mile, they were carried by the wind in a horizontal direction, and descended in a field 27 miles from Paris, having travelled that distance in two hours. M. Charles then ascended alone, and rose to the height of about two miles, without experiencing any other disagreeable sensation than a severe cold and a pain in his ears, owing probably to the expansion of the dense internal air.

A great many aerial voyages were made in France before it was attempted in England.

Vincent Lunardi, an Italian (the first who made an aerial voyage in England), on the 15th of September, 1784, rose from the Artillery-Ground in London, by a balloon 33 feet in diameter, made of silk, oiled, and painted in stripes of blue and red. He took up with him a dog and a cat; the latter was destroyed, and the dog was almost spent. In his ascent, the thermometer fell to 29, and some drops of water round his balloon were frozen. He ascended about five minutes after two o'clock, and arrived at Collier's Hill, five miles beyond Ware, in Hertfordshire, at 25 minutes after four.

Mr. Sadler, of Oxford, was the first Englishman who ascended with a balloon. He constructed one himself, with which he rose from Oxford on the 4th of October; and a second time on the 12th, and sailed 15 miles in 18 minutes.

M. Blanchard and Dr. Jeffries, on the 7th of the same month, crossed the Channel between Dover and Calais, by means of a balloon; but had such difficulty to keep it above water, that they were obliged to throw away every thing they had with them.

Mr. M'Guire, on the 12th of May, having ascended from Dublin, was carried with great velocity towards the sea, into which he descended, and was taken up by a boat, when on the point of expiring with fatigue.

M. Pilatre de Rozier and M. Romain, on the 15th of July, ascended from Boulogne, with an intention of crossing the Channel, but their balloon, being a *Montgolfier*, or fire-balloon, took fire at the height of 1200 yards, and they fell to the ground and were dashed to pieces.

M. Blanchard, in August, made an aerial voyage from Lisle, to the distance of 300 miles, before he descended. He had also a parachute attached to his car; with this he dropped a dog, which descended gently and without injury.

The rage for aerostatic experiment now almost entirely subsided; and the French were the only people who paid any attention to it during the period of the late war. They employed it for reconnoitring in the army; and it is said that they gained the battle of Fleurus through information obtained in this way.

Notwithstanding the numerous ascents that have been made in various countries, scarcely any con-

siderable improvement had been made. The addition of a parachute, however, lessens much the danger of this machine.

The parachute is, in fact, only a large umbrella, which the aeronaut attaches to his body, and with which he descends in perfect safety when separated from the balloon. The first experiments were made by causing dogs to descend from the balloon with umbrellas or small parachutes attached; and Garnerin was the first who successfully descended from a balloon with a parachute.

The imagination can scarcely figure to itself any thing more daring than such an exploit. On September 21, 1802, M. Garnerin ascended alone from St. George's-parade, North Audley-Street, Grosvenor-square. He went to the height of 8000 feet before he cut away the parachute, to which he was suspended. His descent for the first thirty seconds was astonishingly rapid. The parachute then expanded, and came down steadily; but it soon began to swing; and this motion increased to such a degree, that all were alarmed for the safety of the aeronaut. When it came near to the earth the swinging motion decreased, and he alighted without any injury. The velocity with which he came to the ground, was the same as if he had leaped from a height of four feet.

Notwithstanding the extraordinary nature of the discovery of air-balloons, it has not yet been applied to any useful purpose. The machine may be elevated or lowered at pleasure, by throwing out ballast, or letting out some inflammable air; but no means have yet been found, by which it can be steered in any other direction than that of the wind. This has prevented it from being applied to the purposes of travelling; nor have we acquired

by its means much addition to our knowledge of the atmosphere, owing partly to the recentness of the discovery, and partly to a deficiency of philosophical knowledge in most of the adventurers.

The agreeable stillness and tranquillity aloft in the atmosphere have been matter of general observation. On arriving at a considerable height, great cold has always been experienced; and clouds have been passed through, which contained sometimes snow, and sometimes lightning. The view of the country below is said to be inconceivably grand.

Upon the whole, considering the number of voyages that have been made, but few accidents have happened; and these were commonly owing to the bad construction of the apparatus. The balloon seems, when properly managed, to be quite as safe as any other species of conveyance.

*On the Mode of Constructing and Filling Balloons.*

There are, as has been already mentioned, two kinds of balloons; those raised with heated, or rarefied air, and those filled with inflammable air.

The best forms for balloons are, that of a globe, and an egg-like figure. Fire-balloons, or those raised by heated air, if very large, may be made of linen, or silk; and must be open at bottom, having a hoop round the opening, from which is suspended the grate for the fuel, which is best of straw, or other light combustibles. Small balloons of this kind may be made of tissue-paper, having a wire round the bottom. Two cross wires may support in the centre of the opening a little cup, with some cotton and spirits of wine, the flame of which will rarefy the air, and raise the machine.



Large balloons for inflammable air must be made of silk, and varnished over, so as to be air-tight. To the upper part of the balloon there should be fitted a valve, opening inwards, to which a string should be fastened, passing through a hole made in a small piece of wood, fixed in the lower part of the balloon; so that the aeronaut may open the valve when he wishes to descend. The action of the valve is effected by a round brass plate, having a hole about two or three inches diameter, covered on both sides with strong smooth leather: on the inside there is a shutter of brass, covered also with leather, which serves to close the hole: it is fastened to the leather of the plate, and kept against the hole by a spring. To the lower part of the balloon a pipe is fixed, made of the same materials with the balloon, which serves to fill it by.

The car, or boat, is made of wicker-work, covered with leather, and well varnished, or painted, and is suspended by ropes proceeding from the net which goes over the balloon. This netting should cover the upper part, and come down to the middle, with various cords proceeding from it to the circumference of a circle, about two feet below the balloon. From that circle other ropes go to the edge of the boat. This circle may be made of wood, or of several pieces of slender cane bound together. The meshes of the net should be small at top (against which part of the balloon the inflammable air exerts the greatest force), and increase in size as they recede from the top.

The inflammable air for filling the balloon is procured, by putting a quantity of iron-filings, or turnings, with some oil of vitriol diluted with water, into casks lined with lead. From the top of

these casks tin tubes proceed, which unite into one that is connected with the silk tube of the balloon.

Balloons cannot be made smaller than five or six feet in diameter, of oiled silk, as the weight of the material is too great for the air to buoy it up. They may be made smaller, of thin strips of bladder, or other membrane, glued together. The best for this purpose is the allantois of a calf, which is the membrane which encloses the fœtus in the womb. With this they may be made 18 inches in diameter.

#### OF THE WINDS.

*Wind* is a stream or current of air. As air is a fluid, its natural state is that of rest, which it endeavours always to keep or retrieve by an universal equilibrium of all its parts. When, therefore, this natural equilibrium of the atmosphere happens, by any means, to be destroyed in any part, there necessarily follows a motion of all the circumjacent air towards that part, to restore it; and this motion of the air is what we call wind.

If the air were uniformly of the same density at the same height, and the lighter parts always reposed upon the heavier, it is evident that the lateral pressure being equal in every horizontal direction, it would remain at rest; but if, on the contrary, any portion or part of the air were heavier than the rest, it would descend, or, if lighter, ascend, until the equilibrium was restored; so that either the displaced air would occasion a wind, diverging from a central space, in consequence of the descent or pouring down of the heavier air; or else the air, rushing in, would occasion a wind converging to a central space, in consequence of the descent or pouring down of the heavier air; or

else the air rushing in, would occasion a wind converging to a central space, to supply the lighter ascending stream. It is, therefore, evident, that any agent that alters the density of a part of the air will produce a wind.

The density of the air is changed by compression and by heat. Its elasticity is increased by the addition of moisture; and electricity may have some effect of the same kind.

In considering the causes of winds, the principal agent to be attended to must be heat.

The different winds may be reduced to three classes, viz. general, periodical, and variable winds.

The general winds are usually called *trade-winds*. They always blow nearly in the same direction. In the open seas, that is, in the Atlantic and Pacific Oceans, under the equator, the wind is found to blow almost constantly from the eastward: this wind prevails on both sides of the equator, to the latitude of  $28^{\circ}$ . To the northward of the equator, the wind is between the north and east; and the more northerly, the nearer the northern limit. To the southward of the equator, the wind is between the south and east; and the more southerly, the nearer the southern limit.

*Periodical winds* are such as blow in a certain direction for a time; and at stated seasons change, and blow for an equal space of time from the opposite point of the compass. These may be divided into two classes, viz. *monsoons*, or winds that change annually; and *land and sea breezes*, or winds that change diurnally.

In the sea between Madagascar and New Holland, the S. E. wind extends no farther to the northward than about the tenth degree of south latitude, the

other ten degrees being occupied by wind from the opposite point of the compass; or N. W.; at the same time that the winds in all the northern parts of the Indian Ocean shift round, and blow directly contrary to the course they held in the former six months. These winds are called monsoons, or shifting trade-winds.

These changes are not suddenly made. Some days before and after the change, there are calms, variable winds, and dreadful storms, attended with thunder, lightning, and rain.

On the greater part of the coasts of lands situated between the tropics, the wind blows towards the shore in the day-time, and towards the sea in the night. These periodical winds are termed the land and sea breezes.

When several winds converge swiftly to one point, the air ascends with greater rapidity, and acquires a whirling motion, like that of water descending in a funnel. And as the centrifugal force in this whirling motion of the water, is often sufficient to counterpoise the lateral pressure, and to prevent its approaching the central part, it frequently happens, that a perforation is seen quite through the body of the fluid. In like manner, the centrifugal force of the air may become equal to the pressure of the atmosphere, and consequently leave a void space about the centre of the motion. The phenomenon is called a whirlwind, and sometimes produces fatal effects. For, partly by the expansion of the air included in houses and other buildings; and partly by the violence of the ascending current, it happens that bodies near the centre of the whirl are blown up into the vacuum, or carried aloft with great impetuosity in a spiral motion.

If one of these whirlwinds happen at sea, the pressure of the atmosphere being taken off that part of the surface over which the vacuum is formed, the water, on the principle of the Torricellian tube, will rise to the height of thirty-two or thirty-three feet, before it will be in equilibrio with the external pressure. The ascending warm air, being most probably charged with vapours, will suffer them to be condensed as it arrives at a colder region, and thus, the course of the current will be marked by a dense and opaque vapour, and by the continual ascent a cloud will be formed above. This forms the phenomena of *water-spouts*. At first a violent circular motion of the sea is observed, sometimes for the space of twenty feet diameter: this rises afterwards by degrees into a tapering column of about thirty feet in height, at the same time that a cloud appears, from which a dark line or column descends. This column is met by another, which ascends somewhat like smoke in a chimney, from the lower or solid part of the spout. After this junction the cloud continually increases until the whirl ceases, and the appearance terminates.

## HYDRAULICS.

**H**YDRAULICS is the science which teaches us how to estimate the swiftness and force of fluids in motion, and upon these principles many machines worked by water are constructed.

When an open vessel full of liquor is pierced at the bottom, the liquor spouts out with great force; but as it continues to run, it flows more feebly.

If a hole be made in the side of a vessel, the water will spout out horizontally, because fluids press equally in all directions.

The velocity with which water spouts out at a hole in the side or bottom of a vessel, is as the square root of the depth or distance of the hole below the surface of the water: for, in order to make double the quantity of a fluid run through one hole as through another of the same size, it will require four times the pressure of the other, and, therefore, the aperture must be four times the depth of the other below the surface of the water; and for the same reason, three times the quantity running in an equal time through the same sort of hole, must run with three times the velocity, which will require nine times the pressure, and consequently the hole must be nine times as deep below the surface of the fluid, and so on.

To prove this by experiment: let two pipes of equal sized bores be fixed into the side of a vessel, one pipe being four times as deep below the surface of the water in the vessel as the other is; and whilst the pipes run, let water be poured constantly into the vessel, so as to keep it always full. Then, if a cup that holds a pint be so placed as to receive the water that spouts from the upper pipe, and at the same moment a cup that holds a quart be placed to receive the water from the lower pipe, both cups will be filled at the same time by their respective pipes.

The horizontal distance to which a fluid will spout from a horizontal pipe, in any part of the side of an upright vessel below the surface of the fluid, is equal to twice the length of a perpendicular to the side of the vessel, drawn from the mouth of the pipe to a semicircle described upon the altitude of the fluid: and, therefore, the spout will be to the greatest distance possible from a pipe whose mouth is at the centre of the semicircle; because a perpendicular to its diameter, (supposed parallel to the side of the vessel) drawn from that point, is the longest that can possibly be drawn from any part of the diameter to the circumference of the semicircle.

Thus, if the vessel  $A B$  (Plate 8. fig. 12.) be full of water, the horizontal pipe  $D$  in the middle of its side, and the semicircle  $N E C$  be described upon  $D$  as a centre, with the radius or semidiameter  $D C$ , or  $D N$ , the perpendicular  $D E$  to the diameter  $C D N$  is the longest that can be drawn from any part of the diameter to the circumference: and if the vessel be kept full, the jet will spout from the pipe  $D$  to the horizontal distance

MM, which is double the length of the perpendicular DE. If two other pipes, as F and G, be fixed into the side of the vessel, at equal distances above and below the pipe D, the perpendiculars FH and GI, from these pipes to the semicircle, will be equal; and the jets spouting from them will each go to the horizontal distance NK, which is double the length of either of the perpendiculars FH or GI.

The reader will easily perceive, that the curves described by the spouting fluid, in all the different situations, will be that of a parabola; being acted upon by the combined forces of the lateral pressure of the fluid in the vessel, and the force of gravity.

When water issues through the aperture in the side of a vessel, a smaller quantity runs out than what might be expected from the pressure of the fluid in the vessel; because the stream is contracted at a small distance from the aperture, owing to the oblique direction of some of the particles of the water in arriving at the aperture within, and thus crossing each other as they come out. If a short *cylindrical* pipe be added to the aperture, the delivery is increased in a certain degree; but a much greater quantity flows when the short pipe or *ajutage*, as it is called, is made of the form of a *frustum of a cone*, the smaller end being towards the vessel.

We have seen that water will run through bended pipes to the same level as the reservoir from which it proceeds. So, also, if the pipe through which the water issues in an open vessel be turned upwards, the water will form a *jet* or *fountain* (see Plate 8. fig. 12.), and will rise nearly as high as the surface



of the water in the reservoir; but it will not rise quite so high, owing to the resistance of the air and the friction in the ajutage.

### THE SYPHON.

A syphon, generally used for decanting liquors, is a bended pipe, whose legs are of unequal lengths, as A B (Plate 8. fig. 14.) If a small bent tube, whose legs are of equal lengths, be filled with water, and turned downwards, the fluid will not run off, but remain suspended therein, so long as it is held exactly level; but when an inclination is given to either leg, whereby the perpendicular altitude of one is in effect made shorter than the other, the water will flow from the lowest leg, and will continue to run till the vessel is emptied.

The theory of this is as follows: the air is a fluid, whose density near the surface of the earth is experimentally found to be to that of water, at a medium, as to 1 to 850; so that 850 gallons of air, near the earth, weigh as much as one gallon of water. Now, according to the nature of all other fluid bodies, the air presses the surface of all things exposed to it every way equally. When, therefore, the legs of the syphon, equal in length, are turned down, the weight of the atmosphere above being kept off by the machine, the under air, bearing against and repressing the water which tends to fall out of both of them with equal force, keeps it in suspense, and prevents its motion; but when, by inclining it to either side, we in effect shorten one of its legs, and lengthen the other in perpendicular altitude, the balance is destroyed, and the longest will preponderate.

And, to observe how small an inclination will answer this purpose, one need only take a couple of jars full of water, and hang a small syphon, whose legs are of equal lengths, upon the edge of one; the external leg whereof will, from the sloping of the jar, naturally incline a little, and the syphon will soon begin to act; then taking it on the edge of the other jar, the like will immediately happen; and thus reciprocally the effect may be produced as often and as suddenly as you please.

It is evident from what has been said, that when the two legs of the syphon are of equal length, they are equally pressed by the atmosphere, and consequently no motion ensues; but when the syphon is inclined, the perpendicular height of the one is made greater than that of the other, and the weight of the water in the one overbalances that in the other, and begins to flow. On this account, in practice, one of the legs of the syphon is made longer than the other, that the effect may take place without inclining the instrument.

In order to make a syphon act, it is necessary, first, to fill both legs quite full of the fluid, and then the shorter leg must be placed in the vessel to be emptied. Immediately upon withdrawing the finger from the longer leg, the liquor will flow. If the perpendicular height of a syphon, from the surface of the water to its bended top, be more than 33 feet, it will draw no water, even though the other leg were much longer, and the syphon quite emptied of air; because the weight of a column of water 33 feet high, is equal to the weight of a column of air reaching from the surface of the earth to the top of the atmosphere. Mercury may be drawn through a syphon, in the

same manner as water ; but then the utmost height of the syphon must always be less than 30 inches, as mercury is nearly 14 times heavier than water. The syphon may be filled, by pouring some of the fluid into it, or by placing the shorter leg in the vessel, and sucking the liquor through the longer leg. Some, as Fig. 15., are made with a sucking-pipe attached to the longer leg. Syphons are extremely convenient for decanting liquors of various kinds, as they do not disturb the sediment.

A syphon may be disguised in a cup, from which no liquor will flow until the fluid be raised therein to a certain height ; but when the efflux is once begun, it will continue until the vessel be emptied. For instance, fig. 16. Plate 8. is a cup, in the centre of which is fixed a glass pipe, continued through the bottom, over which is put another glass tube, made air-tight at top by means of the cork, but left so open at foot, by holes, that water may freely rise between the tubes as the cup is filled : until the fluid in the cup shall have gained the top of the inmost pipe, no motion will take place ; the air, however, from between the two pipes, being in the mean time extruded, by the rise of the denser fluid, and passing down the inner tube, will get away at bottom ; and the water, as soon as the top of the enclosed tube shall be covered thereby, will very soon follow, and continue to rise in this machine, as in the syphon, until the whole has run off. This is called *Tantalus' cup* ; and to make the thought more humorous, a hollow figure is sometimes put over the inner tube, of such length, that when the fluid has got nearly up to the lips of the man, the syphon may begin to act, and empty the cup. It is, in effect, no other than if the two legs of the syphon

were both in the vessel, into which the water being poured, it will rise in the shorter leg of the machine, by its natural pressure upwards, to its own level; and when it shall have gained the bend of the syphon, it will come away by the longer leg, as already described.

Upon the principle of the syphon, also, we may easily account for *intermitting* or *reciprocating springs*. Let A (Fig. 17.) be part of a hill, within which there is a cavity B B, and from this cavity a vein, or channel, running in the direction B C D. The rain that falls upon the side of the hill will sink, and strain through the small pores and crevices in the hill, and fill the cavity B B with water. When the water rises to the level of C, the vein B C D will be full, and the water will run through it as a syphon, and will empty the cavity B B. It must then stop, and when the cavity is again filled, it will begin to run again.

#### ON PUMPS.

The pump is at once the most common and the most useful of all hydraulic engines. It was first invented by Ctesibius, a mathematician of Alexandria, about 120 years B.C.

Of this machine there are three kinds, viz. the sucking, the lifting, and the forcing-pump. By the two last, water may be raised to any height, with an adequate apparatus and sufficient power; by the sucking-pump, it can only be raised 33 feet from the surface of the water, as was observed when treating on pneumatics, though, in practice, this kind of pump is seldom applied to raising water much above 28 feet; because, from the variations observed on the barometer, it is known

that the air is sometimes lighter than 33 feet of water; and whenever that was the case, the pump would fail in its performance.

The *sucking-pump* is an engine both pneumatic and hydraulic. It consists of a pipe open at both ends (Plate 9. fig. 1.), in which is a moveable cylinder or piston, as big as the bore of the pipe in that part wherein it works; and contrived by leathers or other means to fit the bore exactly, so as not to allow any air to get between it and the sides of the pipe where it acts. In the piston of the common sucking-pump, there is a valve opening upwards, like a trap-door, to allow the air and water readily to ascend through it, but to prevent either of them from descending. This piston is then called the *bucket*. It is moved up and down in the pipe by a rod fastened to a handle or lever, or such parts of machinery as are intended to work it. The pipe A B usually consists of two parts; of which the first, A D, is called the barrel, or the working barrel, and is wider, to contain the piston; and the other, D B, is called the suction-pipe, which is of a smaller diameter.

At the joining of the working-barrel with the suction-pipe, there is a fixed valve also opening upwards, D. Lastly, the lower end of the suction-pipe is immersed in water, which is admitted into it through small holes, to prevent the entrance of dirt; and at the top of the working-barrel is a wide head, A, and a pipe, E, for the delivery of the water which is raised.

Having thus mentioned the principal parts of the sucking-pump, we shall next describe its mode of operation.

Let the piston C be close down upon the fixed valve D; both the valves remaining shut by their

weight. Draw the bucket C up from D to C ; it is evident, that as it fits the pipe exactly, a vacuum will be formed in that part ; consequently the air in the rest of the pipe under the piston will open the fixed valve D, and fill the part which had been exhausted. But it will be rendered rarer than before ; consequently its spring, not being equivalent to the pressure of the atmosphere upon the water in which the pump is immersed, the water will therefore be forced up into the suction-pipe until the air within be as dense as before, and then it will stop. Upon depressing the piston C a second time, the same effect is repeated, until at last the water lifts the valve D, and comes into the barrel. When the piston now descends, it is forced through the water, which cannot be pushed down through the valve D, because it opens upwards only. The water, therefore, gets above the piston by passing through its valve C ; and when it is next raised, all the water above it will be lifted up, and will run off by the pipe E.

Thus, by alternately raising and depressing the piston, the effect is produced. Every time the bucket is raised, the valve D rises, and the valve C falls ; and at every time the bucket is depressed, the valve D falls, and C rises ; and thus a stream will be produced in some degree continual, but very unequal. This is inconvenient in many cases ; in a pump for domestic uses, for instance, such an irregular stream would make it troublesome to fill a bucket. It is, therefore, usual to have at the head of the pump a cistern, A, and to make the spout small. By this means the water, brought up by the successive strokes of the piston, rises to such a height in the cistern, as to produce an efflux by the spout, nearly equable.

At the beginning of the operation, if the leathers be dry, the piston will not exhaust the air sufficiently, and the water will not rise; but if a little water be poured upon the piston, it will swell the leathers, and causing them to fit close, thus make the piston act. This is vulgarly called, fetching the water.

As it is the pressure of the air or atmosphere which causes the water to rise, and follow the piston or bucket as it is drawn up, and not suction, as is commonly supposed; and since a column of water 33 feet high is of equal weight with as thick a column of the atmosphere from the earth to the top of the air, therefore the perpendicular height of the piston or bucket from the surface of the water in the well must always be less than 33 feet; otherwise the water will never get above the bucket. But when the height is less, the pressure of the atmosphere will be greater than the weight of the water in the pump, and will, therefore, raise it above the bucket; and when the water has once got above the bucket, it may be lifted to any height, if the piston-rod be made long enough, and a sufficient degree of strength be employed.

The *lifting-pump* consists of a body, or barrel A B (Fig. 2.), with narrow apertures at the lower end, to prevent the entrance of dirt, stones, or any thing that would impede its operation. At the lower end is a valve, *a*, opening upwards, and allowing the water to pass through it, but preventing it from returning downwards. In the barrel is a piston, *b*, perforated, and having on it a valve, also opening upwards. This piston is moved up and down by a rod, worked by a lever, or other machine. Both the piston and the lower valve,

must be under the surface of the water in the well. When the piston is pushed down, the water below it not being able to go downwards, on account of the valve *a*, raises the valve of the piston, and gets above it; and when the piston is drawn up, it lifts all the water above it; while the pressure of the atmosphere causes more water to supply its place, by lifting the valve *a*. When the piston is moved down again, the same thing is repeated, and more water gets above the piston. In this manner, by successive motions of the piston, the water is at last got to the top, and discharged into the head, from whence it runs out by the spout *D*. In this pump there is always a column of water lifted, whose base is equal to the top of the piston, and whose height is equal to the distance from the piston to the head. It is evident, that this weight will not be made less by diminishing the diameter of the barrel above the piston; because fluids press in proportion to their bases and perpendicular altitudes.

This pump is much used in great water-works; it is the simplest of all in its operation.

The *forcing-pump*, represented in Fig. 3., consists of a barrel, *A B*, and a piston, or forcer, *C*. There are also two fixed valves in this kind of pump; one in some convenient part of the sucking-pipe, as at *D*, the other in the branching or forcing-pipe, as *S*. These ought, in like manner, to be air-tight, and so disposed, as to let the water freely rise, but absolutely to hinder its return.

When the forcer is first moved upwards in the barrel, the air between that and the water below, having room to dilate, by its natural spring, will of course be rarefied; the pressure of the atmosphere being intercepted by the force of the barrel *A B*,



on one hand, and by the upper valve at S in the branching-pipe, on the other, the water will rise from the spring into A B, for the reason already given; and repeated strokes of the piston will fetch up the fluid to the forcer, and fill the cavity of the pipes between the fixed valves D and S. The water in this manner raised, being hindered from going down again by the lower valve, will be pressed by the forcer every time it descends, and be thereby obliged to make its way where there is least resistance, viz. through the upper valve at S. And whenever, on the rising of the forcer, this pressure intermits, the valve at S will immediately close under the weight of the upper water, and prevents its return that way, while the piston is rising with a fresh supply; and this is repeated at every stroke of the forcer.

It is evident, that the operation of a pump is by starts, and that the water in the main remains at rest, pressing on the valve during the time that the piston is withdrawn from the bottom of the working-barrel. It is in most cases desirable to have this motion equable, and in some cases it is absolutely necessary. Thus, in the engine for extinguishing fires, the spout of water, going by jerks, could never be directed with a certain aim, and half of the water would be lost by the way; because a body at rest cannot in an instant be put in rapid motion; and the first portion of every jerk of water would have but a small velocity. A very ingenious contrivance has been fallen upon, for obviating this inconvenience, and procuring a stream nearly equable. At any convenient part of the rising-pipe beyond the valve S, there is annexed a strong and capacious vessel, U, closed at top by a small pipe, T, fixed into it, which

reaches nearly to the bottom of the vessel. When the water is forced along the rising pipe S, it gets into this vessel, and rises above the lower part of the pipe T. The air which is above the water in the vessel, being now confined, and being condensed into a smaller space by the admission of more water at each action of the piston, presses by its elasticity upon the surface of the water, which cannot return by the valve S, and forces it up the pipe T, in a continued stream. This air-vessel must be so large, that the change of bulk of the compressed air during the inaction of the piston, may be inconsiderable; otherwise the stream will not continue until the next stroke.

To describe, or even to enumerate, the immense variety of combinations of these three simple pumps, would fill a volume. We shall select a few which are most deserving of notice.

The common sucking-pump may, by a small addition, be converted into a lifting-pump, fitted for propelling the water to any distance, and with any velocity. Fig. 4. is a sucking-pump, whose working-barrel A B has a lateral pipe C, connected with it close to the top. This terminates in a main, or rising-pipe, furnished, or not, with a valve. The top of the working-barrel A B is shut by a strong plate, having a hollow neck terminating in a small flanch. The piston-rod passes through this neck, and is nicely turned and polished. A number of rings of leather are put over the rod, and strongly compressed round it by another flanch and several screwed bolts. By this contrivance, the rod is closely grasped by the leathers, but may be easily drawn up and down, while all passage of air or water is effectually prevented. The piston is perforated, and furnished with a

valve opening upwards. There is also a valve, T, on the top of the suction-pipe; and it will be of advantage, though not absolutely necessary, to put a valve, L, at the bottom of the rising-pipe. Now, suppose the piston at the bottom of the working-barrel; when it is drawn up, it tends to compress the air above it, because the valve in the piston remains shut by its own weight. The air, therefore, is driven through the valve L, into the rising-pipe, and escapes. In the mean time, the air which occupied the small space between the piston and the valve T, expands into the upper part of the working-barrel; and its elasticity is so much diminished thereby, that the atmosphere presses the water of the cistern into the suction-pipe, where it rises until an equilibrium is again produced. The next stroke of the piston downwards allows the air, which had come from the suction-pipe into the barrel during the ascent of the piston, to get through its valve. Upon drawing up the piston, the air is also drawn off through the rising-pipe. Repeating this process brings the water at last into the working-barrel, and it is then driven along the rising-pipe by the piston.

This is one of the best forms of a pump. The rarefaction may be very perfect, because the piston can be brought so near to the bottom of the working-barrel; and for forcing water in opposition to great pressures, it appears preferable to the common forcing-pump; because in that, the piston-rod is compressed and exposed to bending, which greatly hurts the pump, by wearing the piston and barrel on one side. This soon renders it less tight: and much water squirts out by the sides of the piston. But in this pump the piston-rod is always drawn or pulled, which keeps it straight, and rods

exert a much greater force in opposition to a pull than to compression. The collar of leather round the piston-rod, is found by experience to be very impervious to water; and though it needs but little repair, yet the whole is very accessible, and in this respect much preferable to the common pump in deep mines, where every fault of the piston obliges us to draw up some hundred feet of piston-rods. By this addition, too, any common pump for the service of a house may be converted into an engine for extinguishing fire, or may be made to convey the water to every part of the house; and this without hurting or obstructing its common uses. All that is necessary is to have a large cock on the upper part of the working-barrel, opposite to the lateral pipe in this figure. This cock serves for a spout, when the pump is used for common purposes; and the merely shutting this cock converts the whole into an engine for extinguishing fire, or for supplying distant places with water. It is scarcely necessary to add, that, for these services, it will be requisite to connect an air-vessel with some convenient part of the rising-pipe, in order that the current of water may be continual.

It is of considerable importance, that as equable a motion as possible be produced in the main pipe, which diminishes those strains which it is otherwise liable to. The application of an air-vessel at the beginning of the pipe answers this purpose. In great works, it is usual to effect this by the alternate action of two pumps. It will be rendered still more uniform, if four pumps be employed, succeeding each other at the interval of one quarter of the time of a complete stroke.

But ingenious men have attempted the same

thing with a single pump; and many different constructions for this purpose have been proposed and executed. Fig. 5. represents one of the best. It consists of a working-barrel,  $a b$ , closed at both ends; the piston  $c$  is solid, and the piston-rod passes through a collar of leathers at the top of the barrel. This barrel communicates laterally with two pipes,  $n$  and  $k$ , the communications being as near to the top and bottom of the barrel as possible. At each of the communications are two valves, opening upwards. The two pipes unite in a larger rising-pipe at  $b$ , which bends a little back, to give room for the piston-rod. Suppose the piston down close to the entry of the lateral pipe  $k$ ; when it is drawn up, it compresses the air above it, and drives it through the valve in the pipe  $k$ , whence it escapes through the rising-pipe; at the same time it rarefies the air below it. Therefore, the weight of the atmosphere shuts the valve  $m$ , and causes the water in the cistern to rise through the valve  $n$ , and fill the lower part of the pump. When the piston is pushed down again, this water is first driven through the valve  $m$ , because  $n$  immediately shuts; and then most of the air which was in this part of the pump at the beginning, goes up through it, some of the water coming back in its stead. In the mean time, the air which remained in the upper part of the pump after the ascent of the piston, is rarefied by its descent; because the valve  $o$  shuts as soon as the piston begins to descend, the valve  $p$  opens, the air in the suction-pipe  $h$  expands into the barrel, and the water rises into the pipes by the pressure of the atmosphere. The next rise of the piston must bring more water into the lower part of the barrel, and must drive a little more air through the valve  $o$ ,

namely, part of that which had come out of the suction-pipe *h*; and the next descent of the piston must drive more water into the rising-pipe *h*, and along with it, most, if not all, of the air which remained below the piston, and must rarefy still more the air remaining above the piston; and more water will come in through the pipe *h*, and get into the barrel. It is evident, that a few repetitions will at last fill the barrel on both sides of the piston with water. When this is accomplished, there is no difficulty in perceiving how, at every rise of the piston, the water of the cistern will come in by the valve *n*, and the water in the upper part of the barrel will be driven through the valve *o*; and in every descent of the piston, the water of the cistern will come into the barrel by the valve *p*, and the water below the piston will be driven through the valve *m*; and thus there will be a continual influx into the barrel through the valves *n* and *p*, and a continual discharge along the rising-pipe *l*, through the valves *m* and *o*.

This machine is certainly equivalent to two forcing-pumps, although it has but one barrel and one piston; but it has no sort of superiority. It is not even more economical, in most cases; because, probably, the expense of the additional workmanship will equal that of the barrel and piston which is saved. There is, indeed, a saving in the rest of the machinery; because one lever produces both motions. It, therefore, cannot be called inferior to two pumps; and there is undoubtedly some ingenuity in the contrivance.

Fig. 6. is another pump for furnishing a continued stream, invented by Mr. Noble. A B, the working-barrel, contains two pistons, C and B, which are moved up and down alternately by the rods fixed

to the lower F. The rod of the piston B, is carried through the piston, or bucket C. This pump is very simple in its principle, and may be executed at little expence.

The pump invented by M. de la Hire raises water equally quick by the descent, as by the ascent, of the piston in the pump-barrel.

A A (Fig. 7.), is a well, in which the lower ends of the pipes B and C are placed. D is the pump-barrel, into the lowermost end of which the top of the open pipe B is soldered, and in the uppermost end the hollow pipe S is soldered, which opens into the barrel; and the top of the pipe C is soldered into that piece. Each of these pipes has a valve on its top, and so have the crooked pipes E and F, whose lower ends are open into the pump-barrel, and their upper ends into the box G. L is the piston-rod, which moves up and down through a collar of leather in the neck M; K is a solid plunger, fastened to the rod or spear L: the plunger never goes higher than K, nor lower than D; so that from K to D is the length of the stroke.

As the plunger rises from D to K, the atmosphere (pressing on the surface of the water A A in the well) forces the water up the pipe B, through the valve *b*, and fills the pump-barrel with water up to the plunger; and during this time, the valves *e* and S lie close and air-tight on the tops of the pipes E and C.

When the plunger is up to its greatest height, at K, it stops there for an instant, and in that instant the valve *b* falls, and stops the pipe B at top. Then, as the plunger goes down, it cannot force the water between K and D back through

the close valve *b*, but forces all that water up the crooked pipe *E*, through the valve *c*, which then opens upward by the force of the water; and this water, after having filled the box *G*, rises into the pipe *N*, and runs off by the spout at *O*.

During the descent of the plunger *K*, the valve *f* falls down, and covers the top of the crooked pipe *F*; and the pressure of the atmosphere on the well *A* forces the water up the pipe *C*, through the valve *S*, which then opens upward by the force of the ascending water; and this water runs from *S* into the pump-barrel, and fills all the space in it above the plunger.

When the plunger is down to its lowest descent at *D*, and stops there for an instant, in that instant the valve *S* falls down, and shuts the top of the pipe *C*; and then, as the plunger is raised, it cannot force the water above it back through the valve *S*, but drives all that water up to the crooked pipe *F*, through the valve *f*, which opens upward by the force of the ascending water; which water, after filling the box *G*, is forced up from thence into the pipe *N*, and runs off by the spout at *O*.

And thus, as the plunger descends, it forces the water below it up the pipe *E*; and as it ascends, it forces the water above it up the pipe *F*, the pressure of the atmosphere filling the pump-barrel below the plunger, through the pipe *B*, while the plunger ascends, and filling the barrel with water above the plunger, through the pipe *C*, as the plunger goes down.

And thus there is as much water forced up the pipe *N*, to the spout *O*, by the descent of the plunger, as by its ascent; and, in each case, as much water discharged at *O*, as fills that part of



the pump-barrel which the plunger moves up and down in.

On the top of the pipe O is a close air-vessel P. When the water is forced up above the spout O, it compresses the air in the vessel P; and this air, by the force of its spring acting on the water, causes the water to run off by the spout O, in a constant and (very nearly) equal stream.

Whatever the height of the spout O is above the surface of the well, the top S, of the pipe C, must not be 32 feet above that surface; because if that pipe could be entirely exhausted of air, the pressure of the atmosphere in the well would not force the water up the pipe to a greater height than 32 feet: and if S be within 24 feet of the surface of the well, the pump will be so much the better.

The *hair-rope* machine for raising water was invented by Sieur Vera.

A (Fig. 8.) is a wheel four feet over, having an axis and a winch: C C, a hair-rope, near one inch diameter: D, a reservoir to collect the water: E, a spout to convey the water from the reservoir: G, the surface of the water in the well: I, a pulley under which the rope runs, in order to keep it tight.

When the handle is turned about with a considerable velocity, the water which adheres to the rope (in wells of no great depth), is very considerable; the rope thus passes through the tubes in D, which, being five or six inches higher than the bottom of the reservoir, hinders the water from returning back into the well, and is conveyed in a continual stream through the spout E. Some of the above engines have raised a greater quantity of water, than any person unskilful in hydraulics

could suppose, in the same time, from such a simple contrivance.

The *chain-pump* consists of two square or cylindrical barrels, through which a chain passes, having a great number of flat pistons, or valves, fixed upon it at proper distances. This chain passes round a kind of wheel-work, fixed at one end of the machine. The teeth of this are so contrived as to receive one-half of the flat pistons, which go free of the sides of the barrel by near a quarter of an inch, and let them fold in, and they take hold of the links as they rise. A whole row of the pistons, which go free of the sides of the barrel by near a quarter of an inch, are always lifting when the pump is at work, and as this machine is generally worked with briskness, they bring up a full bore of water in the pump. It is wrought either by one or two handles, according to the labour required.

The many fatal accidents which happen to ships from the choaking of their pumps makes it an important object, in naval affairs, to find some machine for freeing ships from water, not liable to so dangerous a defect. The chain-pump being found least exceptionable in this respect, was adopted in the British navy; but the chain-pump itself is not free from imperfections. If the valves are not well fitted to the cylinder, through which they move, much water will fall back; if they are well fitted, the friction of many valves must be considerable, besides the friction of the chain round the sprocket-wheels, and that of the wheels themselves. To which may be added, the great wear of leathers, and the disadvantage which attends the surging and breaking of the chain. The preference, therefore, which has been given to chain-pumps over

those which work by the pressure of the atmosphere, must have arisen from one circumstance, that they have been found less liable to choak.

In point of friction, of coolness, and of cheapness, the sucking-pump has so evidently the advantage over the chain-pump, that it will not fail to gain the preference, whenever it shall be no longer liable to be choaked with gravel and with chips.

Buchanan's pump, which, like the common pump, acts by the pressure of the atmosphere, is not liable to the defects incident to other pumps upon that principle, being essentially different from any now in use.

The principal object of its invention was to remove the imperfection of choaking, and in attaining this important end, a variety of collateral advantages have also been produced, which enhance its utility.

The points in which it differs essentially from the common pump, and by which it excels, are, that it discharges the water below the piston, and has its valves lying near each other.

The advantages of this arrangement are, that the sand or other matter, which may be in the water, is discharged without injuring the barrel or the piston-leathers; so that besides avoiding unnecessary tear and wear, the power of the pump is preserved, and not apt to be diminished or destroyed in moments of danger, as is often the case with the common and chain-pumps—that the valves are not confined to any particular dimensions, but may be made capable of discharging every thing that can rise in the suction-piece, without danger of being choked—that if there should happen upon any occasion to be an obstruction in the

valves, they are both within the reach of a person's hand, and may be cleared at once, without the disjunction of any part of the pump—and that the pump is rendered capable of being instantaneously converted into an engine for extinguishing fire. Besides, it occupies very little space in the hold, and thus saves room for stowage.

But this pump is not confined to nautical uses alone; its adaptation extends to the raising of water in all situations, and with peculiar advantage where it happens to be mixed with sand, or substances which destroy other pumps, as, for instance, in alum-works, in mines, in quarries, in the clearing of foundations; and in its double capacity it will be very convenient in gardens, bleaching-grounds, in stable and farm-yards, and in all manufactories, or other places, where there is a necessity for raising water, and the risk of fire.

With all these advantages, it is a simple and durable pump, and may be made either of metal or wood, at a moderate expence.

Fig. 9. is a vertical section of the pump, as made of metal, in which A is the suction-piece, B the inner valves, C the outer valve.

The valves are of the kind called *clack-valves*. Their hinges are generally made of metal, as being more durable than leather.

D the working-barrel, E the piston, G the spout.

The following parts are necessary only when the pump is intended to act as a fire-engine.

H an air-vessel, which is screwed like a hose-pipe, that it may, at pleasure, the more readily be fixed or unfixed.

There is a perforated stopple for the spout, made for receiving such pipes as are common to fire-engines. It is oval and tapered, and being intro-

duced transversely, upon being pulled back becomes immediately tight.

These parts being provided, all that is necessary to make the pump act as a fire-engine, after having been used as a sucking-pump, is to plug up the spout with the stopple.

No particular mode being essential in the working of this pump, it may, according to choice, or circumstances, be wrought by all the methods practised with the common pump. In many cases, however, it may be advantageous to have two of them so connected, as to have an alternate motion, in which case, one air-vessel, and even one suction-piece, might serve both.

Its principles admit of various modifications; but as what is already mentioned, may be sufficient to indicate its superiority over the common and chain-pumps, and the advantages likely to result from its general use, a further detail is unnecessary.

To this we may add, that the testimonies of several navigators confirm in the fullest manner, the hopes that were conceived of its utility, and warrant the recommendation of it, as the best adapted for the purpose of any pump hitherto invented.

The great desideratum in a piston is, that it be as tight as possible, and have as little friction as is consistent with this indispensable quality.

The common form, when carefully executed, has these properties in an eminent degree, and accordingly keeps its ground amidst all the improvements which ingenious artists have made. It consists of a hollow cylinder, having a piece of strong leather fastened round it, to make it fit exactly the bore of the barrel, and a valve or flap

to cover the hole through which the water rises. The greatest difficulty in the construction of a piston is to give a sufficient passage through it for the water, and yet allow a firm support for the valve and fixture for the piston-rod. It occasions a considerable expence of the moving power to force a piston with a narrow perforation through the water lodged in the working-barrel. There can be no doubt, therefore, that metal pistons are preferable, because their greater strength allows much wider apertures. For common purposes, however, they are made of wood, as elm or beech.

There are many ingenious contrivances to avoid the friction of the piston in the pumps; but this is of little importance in great works, because the friction, which is completely sufficient to prevent all escape of water in a well-constructed pump, is but a trifling part of the whole force.

In the great pumps which are used in mines, and are worked by a steam-engine, it is very usual to make the pistons and valves without any leather whatever. The working-barrel is bored truly cylindrical, and the piston is made of metal, of a size that will just pass along it without sticking. When this is drawn up with a velocity competent to a properly loaded machine, the quantity of water which escapes round the piston is insignificant. The piston is made without leathers, not to avoid friction, which is also insignificant in such works, but to avoid the frequent necessity of drawing it up for repairs through such a length of pipes.

If a pump absolutely without friction be wanted, the following seems preferable, for simplicity and performance, to any we have seen, when made use of in proper situations. Let *N O* (Fig. 10.) be the surface of the water in the pit, and *K* the place

of delivering. The pit must be as deep in water as from K to N O. A is a wooden trunk, round or square, open at both ends, and having a valve, P, at the bottom. The top of this trunk must be in a level with K, and has a small cistern, F. It also communicates laterally with a rising-pipe G, furnished with a valve opening upwards. L is a beam of timber, so fitted to the trunk, as to fill it without sticking, and is of at least equal length. It hangs by a chain from a working-beam, and is loaded on the top with weights exceeding that of the column of water which it displaces.

Now, suppose this beam to descend from the position in which it is drawn in the figure; the water must rise all round it, in the crevice which is between it and the trunk, and also in the rising-pipe; because the valve P shuts and O opens; so that when the plunger L has got to the bottom, the water will stand at the level of K. When the plunger is again drawn up to the top by the action of the moving power, the water sinks again in the trunk, but not in the rising-pipe, because it is stopped by the valve O. Then allowing the plunger to descend again, the water must again rise in the trunk to the level of K, and it must now flow out at K; and the quantity discharged will be equal to the part of the beam below the surface of the pit-water, deducting the quantity which fills the small space between the beam and the trunk. This quantity may be reduced almost to nothing; for if the inside of the trunk, and the outside of the beam, be made tapering, the beam may be let down till they exactly fit; and as this may be done in square work, a good workman may make it exceedingly accurate. But, in this case, the lower half of the beam, and trunk, must not

taper; and this part of the trunk must be of sufficient width round the beam, to allow free passage into the rising-pipe; or which is better, the rising-pipe must branch off from the bottom of the trunk. A discharge may be made from the cistern F, so that as little water as possible may descend along the trunk, when the piston is raised.

The requisites of a valve are, that it be tight, and of sufficient strength to resist the great pressures to which it is exposed; that it afford a free passage to the water; and that it do not allow much to go back whilst it is shutting. The *clack-valve* is of all others the most obvious and common. It consists merely of a leather flap covering the aperture, and having a piece of metal on the upper side, both to strengthen and to make it heavier, that it may shut of itself. Sometimes the hinge is of metal. The hinge being liable to be worn by such incessant motion, and as it is troublesome, especially in deep mines, and under water, to undo the joint of the pump, in order to put in a new valve, it is frequently annexed to a box like a piston, made a little conical on the outside, and dropped into a conical seat made for it in the pipe, where it sticks fast; and to draw it up again, there is a handle like that of a basket, fixed to it, which can be laid hold of by a long grappling-iron. The only defect of this valve is, that by opening very wide, when pushed up by the stream of water, it allows a good deal to go back during its shutting again.

The *butterfly-valve* is free from most of these inconveniences, and seems to be the most perfect of the clack-valves. It consists of two semicircular flaps, revolving round their diameters, which are fixed to a bar placed across the opening through



the piston. Some engineers make their great valves of a pyramidal form, consisting of four clacks, whose hinges are in the circumference of the water-way, and which meet with their points in the middle, and are supported by four ribs, which rise up from the sides, and unite in the middle. This is a most excellent form, affording a more spacious water-way, and shutting very readily.

There is another form of a valve, called the *button*, or *tail-valve*. It consists of a plate of metal turned conical on the edge, so as exactly to fit the conical cavity of its box. A tail projects from the under side, which passes through a cross bar in the bottom of the box, and has a little knob at the end, to hinder the valve from rising too high. This valve, when nicely made, is unexceptionable. It has great strength, and is therefore proper for all severe strains; and it may be made perfectly tight by grinding. Accordingly, it is used in all cases where tightness is of indispensable consequence. It is most durable, and the only kind that will do for passages where steam or hot water is to pass through.

A pump intended to raise water to any height whatever, will always work as easy, and require no greater power to give motion to the bucket, if both the valves be placed towards the bottom of the pipe, than if they were fixed 33 feet above the surface of the water.

The playing of the piston thus low in the pipe will, besides, prevent an inconvenience which might happen were it placed above, viz. in case of a leak beneath the bucket, which, in a great length of pipe, may very easily happen; the outward air getting through, would hinder the necessary rare-

faction of the air in the barrel on moving the piston : and consequently the pump might fail in its operation. This can only effectually be prevented, by placing the pump-work in or near the water ; in which case, should any leak happen upward, it will only occasion the loss of some of the water, without any other inconvenience. And the leather valves, being kept under water, will always be found supple, pliant, and in condition to perform their office.

Placing the pump-work (that is, the valve and piston) pretty low and near together, will also prevent the inconvenience of not being able, in all cases, to fetch up water from the spring by the ordinary pump, when of an equal bore, by reason of the shortness of the stroke ; which, therefore, cannot rarefy the air sufficiently to bring the water up to the piston from the lower valve. For instance : take a smooth barrelled-pump, 21 feet long, having its piston fetching, suppose a foot-stroke, placed above, and the clack or fixed valve at the other end below. By the playing of the piston, admit it possible for water to rise 11 feet ; or if you will, let water be poured on the clack, to the height of 11 feet, and refit the piston, there will remain still 9 feet of air between it and the water, which cannot be sufficiently rarefied by a foot-stroke to open the clack, or fetch up more water ; for, in this case, the air can only be rarefied in the proportion of 9 to 10 ; whereas, to make a bare equilibrium with the atmosphere, it ought to be as 9 to  $13\frac{1}{2}$  : since, as 22 or the complement of 11, to 33 feet of water, the weight of the whole atmosphere, so is the interval spoken of, 9 to  $13\frac{1}{2}$  : to complete which, the stroke ought to be at least  $4\frac{1}{2}$  feet long.

However, by filling the whole void between the piston and the clack at first with water, this last objection might be removed.

In some cases, the pump cannot be placed conveniently perpendicular to the well: for example, being to raise water out of the well at A, by means of a pump at B (Fig. 11.), the best way will be to carry the barrel as low as the spring is, communicating therewith by means of the pipe at C. The bucket then playing in the barrel B C, will have the same effect as if the well were made perpendicular to the pump; because the water, by its proper weight, will always replenish B C.

And if it should happen, from some considerable impediment, that the barrel cannot get down to the well directly, it may be led about any other way for sake of convenience. And then making the pipe of conveyance E, less in diameter than the barrel, it will sooner be exhausted of air, by moving the piston; and the water will follow very briskly, as by the leaden pump at B.

It will, however, always be more easy to draw water with pipes that are large, and of an equal bore throughout, because the water will have a less velocity in them, and the friction will be in proportion less. Upon this account, the common pumps made by plumbers frequently do not work easy, because, by making the pipe that brings up water from the spring much less than the bucket, they, as it were, wire-draw the water raised.

Archimedes' screw, (Plate 9. fig. 12.) deserves consideration, not only for its antiquity, but its usefulness in raising water. It consists of a long cylinder, with a hollow pipe-tube, or groove, coiled about it, as represented in the figure. It is placed in a position oblique to the horizon, with the lower

end in the water, the other being supported on the lower part of the winch I, by which the screw and cylinder are turned round. As soon as the screw is immersed in water, it immediately rises therein by the orifice C, to the level of the surface of the water E; and if the point of the helix, or spiral, which in the beginning of the motion is coincident with the surface of the water, happen not to be on the lower side of the cylinder, the water will, upon the motion of the screw, move on in the helix, until it come to the point which is on the under side, and coincident with the watery surface: when it is arrived at that point, which suppose at O, it cannot afterwards possess any other part of the spiral, than that which is upon the lowest part of the cylinder; for it cannot move from O towards H, because H is situated higher; and since this will ever be the case, after the surface of the water in the helix has attained the point E, it is plain, that it must always be on the under side of the cylinder. But since the cylinder is in motion, every part of the spiral-screw, from E to F, will by degrees succeed to the under part of the cylinder: the water, therefore, in the helix, must succeed to every part thereof, from E to F, as it comes on the lower side; that is, it must ascend on the lower part of the cylinder through all the length of the pipe, until it come to the orifice at top, where it will run out, as having nothing farther to support it.

#### STEAM ENGINE.

When water is made to boil by being heated to  $212^{\circ}$ , it is converted into an elastic vapour, called *steam*. This is familiarly known, by observing a

tea-kettle that boils. Steam itself is transparent, and consequently invisible, and it is only by being condensed again into water, that it assumes the misty form by which we see it. The steam from the spout of a tea-kettle is transparent and invisible just as it issues, and does not become visible, till at a small distance from the aperture; it being soon condensed by the atmosphere.

Steam at the temperature of  $212^{\circ}$  is a permanent vapour, possessed of great elasticity, and capable of exerting a prodigious force when confined in close vessels. It can also be heated to a much higher temperature, by which its elasticity and power is still farther increased; and the degree of temperature is the exact measure of its elasticity.

If steam be thrown into a vessel already full of air, it will drive out the air and occupy its place: if then, by the application of cold, the steam within the vessel be condensed into water, a vacuum will be produced in the vessel, since the space occupied by the condensed water is extremely small compared to that which was filled by the steam.

The *steam-engine* is one of the noblest monuments of human ingenuity. It was originally invented by the Marquis of Worcester, in the reign of Charles II. This nobleman published, in 1663, a small book called "*A Century of Inventions,*" describing a hundred discoveries or contrivances of his own; but the descriptions of many of them are so obscure, that they are altogether unintelligible.

Among them is an account of his invention of raising water by the force of steam, which, now that we are possessed of the engine, appears to

agree very well with its construction. But as there is no plate to accompany his description, we are entirely unacquainted with the particular mode in which he applied the power of steam. It does not appear, however, that he met with sufficient encouragement; and this useful discovery was long neglected.

Towards the end of the century, captain Savary, a person of great ingenuity, having probably seen the account of the Marquis of Worcester's invention, was convinced of its practicability, and succeeded in constructing a machine of this kind. He obtained a patent for the invention, and erected several steam-engines which he described in a book entitled "*The Miner's Friend*," published in 1696.

The following is the description of his machine, as improved by himself:

*a* (Plate 10. fig. 1.) is a strong boiler for water, built in a furnace. From the top of this boiler there proceeds a pipe, *b*, which conveys the steam into another strong vessel, *r*, called the *receiver*. This pipe has a cock at *c*, called the *steam-cock*. In the bottom of the receiver is a pipe *S*, which communicates with the rising-pipe *H n k*, the lower end of which is immersed in the well from which the water is to be raised. Immediately below the place where the pipe *S* enters the rising-pipe, there is a valve, *n*, opening upwards. A similar valve is also placed at *i*, above the pipe *S*. Lastly, there is a pipe *e*, which branching off from the rising-pipe, enters the top of the receiver. This pipe has also a cock, *d*, called the *injection-cock*. The mouth of the pipe *e* has on the end *f* a nozzle, pierced full of holes, pointing from a centre in every direction. The keys of the two

cocks *c* and *d*, are united by the handle *h* called the *regulator*.

The mode of operation is as follows. Let the regulator be so placed, that the steam-cock *c* be open and the injection-cock *d* shut: put water into the boiler *a*, and make it boil. The steam from it will enter the pipe *b*, and fill the receiver, first driving out the air which it before contained; a considerable quantity of steam will be at first condensed by the cold sides of the receiver, but it being at length warmed, the steam will proceed into the rising-pipe, lifting up the valve *i*. When this is perceived to be the case, by the rising-pipe feeling warm, and hearing the valve *i* rattle, the communication is now to be cut off from the boiler, by shutting the steam-cock *c*, the injection-cock *d* being also shut. The receiver now gradually cools, and the steam included in it condenses into water. When this is the case, as the air was at first driven out by the steam, and cannot return again, all the cocks being shut, a vacuum is formed in the receiver; consequently, there is nothing to counterbalance the pressure of the atmosphere, which acting upon the water in the well, forces it up the rising-pipe, and fills the receiver. The steam-cock is now opened; and the steam from the boiler rushing in with great violence, presses upon the surface of the water in the receiver, and forcing it through the pipe *s*, into the rising-pipe, causes it to shut the valve *n*, and open the other valve *i*; and provided the steam be sufficiently strong, will force it up the rising-pipe to the top *k*, where it is delivered. The cock *c* is kept open until all the water be driven out of the receiver, and it is again filled with steam. The regulator is now applied, which shuts the steam-cock, whilst at the same

time it opens the injection-cock. The rising-pipe being still full of water, a stream of cold water proceeds through the pipe *e*, and enters the receiver in a shower. This instantly condenses the steam in the receiver, and produces a vacuum as before; in consequence of which, the water from the well is again forced up by the external pressure of the atmosphere, and the receiver is again filled with water. The regulator is then turned, which shuts the injection-cock and opens the steam-cock, permitting the steam from the boiler to press upon the water, and again force it up the rising-pipe. This operation of filling the receiver with water by means of a vacuum produced in it, and forcing it up the rising-pipe by the pressure of the steam from the boiler, is constantly repeated, by merely turning the regulator, which shuts and opens the steam-cocks and injection-cocks alternately.

This construction of this steam-engine is extremely simple, and it might, perhaps, be successfully applied for some purposes. But it has several defects. The action of the direct steam on any definite surface, as, for example, a square inch, is accurately equal to the re-action of the water which is forced up; consequently, Savary's engine will require steam more elastic than the air of the atmosphere, in every case except where the water is raised no higher than it can be by the vacuum that is produced, and the pressure of the atmosphere. When the water is forced up through the rising-pipe, every square inch of the boiler must sustain a pressure equal to a column of water an inch square, and of the height of the pipe above the boiler. This, therefore, requires very strong vessels, and several accidents happened by their



bursting, when the safety valve was loaded too much.

But the greatest defect of this machine is the great waste of steam, and, consequently, of fuel. For when the steam is admitted to the top of the cold water in the receiver, it is condensed with great rapidity; and the water does not begin to yield to its pressure, until its surface be so hot as not to condense any more steam: it then descends, but, as thus, a new part of the side of the receiver is exposed to the steam, more is condensed, so that a condensation of the steam is going on all the while the water is descending. This is repeated at every stroke, as the receiver is cooled every time it is filled with water.

Mr. Savary succeeded in raising water to small heights, and erected several engines in different parts of England; but he failed in deep mines. Many attempts have been made to correct these defects, but hitherto without much success.

At a time when almost all the most valuable mines in England were coming to a stand, for want of more powerful or cheaper machines than were then known, Newcomen and Cauly conceived the project of applying a piston with a lever and other machinery. They joined with Savary, in procuring a patent for it in 1705, and executed many engines which were of vast utility to the mining concerns, occasioning the continuance of mines that must have been neglected, and the opening of new ones.

Fig. 2. exhibits a section of Newcomen's engine: *a* is the boiler built in brick-work. In the top of the boiler is a steam-pipe, *c*, communicating with the cylinder *b*, which is of metal, and is bored very truly. The lower aperture of this pipe is shut by

the plate  $n$ , which is ground very flat, so as to apply accurately to the whole circumference of the orifice. This plate is called the regulator, or steam-cock, and it turns horizontally round an axis,  $o$ , which passes through the top of the boiler, and is fitted by grinding to the socket, so as to be steam-tight. It is opened and shut by a handle fixed to its axis.

In the cylinder  $b$  is a solid piston,  $p$ , well fitted into it, and made air-tight by a packing of leather or soft rope, well filled with tallow; and for greater security, a small quantity of water is kept above the piston.

The piston-rod  $d$  is suspended by a chain, which is fixed to the upper extremity of the arched head  $e$  of the great lever, or *working-beam*,  $e f g$ , which turns on the gudgeon  $f$ . There is a similar arched head  $g$ , at the other end of the beam, to the upper extremity of which is fixed a chain, carrying the pump-rod  $h$ , which raises the water from the mine.

The load on this end of the beam is made to exceed considerably the weight of the piston at the other extremity.

At a small height above the top of the cylinder, is a cistern called the *injection-cistern*,  $i$ . From this descends the *injection-pipe*,  $k$ , which enters the bottom of the cylinder, and terminates in a nozzle pierced with holes. This pipe has a cock,  $l$ , called the *injection-cock*.

At the opposite side of the cylinder, a little above its bottom, there is a lateral pipe,  $m$ , turning upwards at the extremity, and there covered by a clack-valve, called the *snifting-valve*, which has a little dish round it, to hold water for keeping it air-tight.

From the bottom of the cylinder, a pipe *g* proceeds, of which the lower end is turned upwards, and is covered with a valve *r*. This part is immersed in a cistern of water, called the hot-well and the pipe itself is called the *eduction-pipe*.

The boiler is furnished with a safety-valve, called the *puppet-clack*, in the same manner as in Savary's engine. This valve is generally loaded with one or two pounds in the square inch, so that it allows the steam to escape when its elasticity is one-tenth greater than that of the atmosphere. All risk of bursting the boiler is thus avoided, the pressure outwards being very moderate.

When the cistern for the injection-water, *i*, cannot be supplied by pipes from some more elevated source, water is raised by the machine itself. A small lifting-pump, *s*, is worked by a rod, *r*, suspended from a small arch upon the great beam; this forces water through the pipe *t* into the injection-cistern.

The parts of the engine being now described, the operation is as follows :

Suppose the piston and lever in the position represented in the plate, and the water in the boiler in a state of ebullition, the steam and injection-cocks being shut. Having opened the steam-cock, *n*, the steam from the boiler will immediately rush in, and flying all over the cylinder, will mix with the air.

Much of it will be condensed by the cold surface of the cylinder and piston, and the water produced from it will trickle down the sides, and run off by the eduction-pipe. This condensation and waste of steam will go on until the whole cylinder and piston be made as hot as boiling water.

When this happens, the steam will begin to issue through the snifting-valve, slowly at first, and cloudy, being mixed with much air; but, by degrees, it will become more transparent, having carried off the greatest part of the air which filled the cylinder.

When the attendant perceives that the blast at the snifting-valve is strong and steady, and the boiler is supplied with steam of a proper strength, appearing by the renewal of its discharge at the safety-valve, which had stopped while the cylinder was filling, he shuts the steam-cock, *n*, and opens the injection-cock, *l*. The pressure of water in the injection-pipe forces some out into the cylinder, which condenses the steam and forms a partial vacuum, as explained above.

The upper side of the piston is now exposed to the whole pressure of the atmosphere, which not being counterbalanced on the under side, will act with its whole force on the piston, and, provided there be not too much weight on the other end, will raise it, the piston going to the bottom of the cylinder.

When the piston has gone down as low as necessary, the injection-cock is shut, and the steam-cock opened. The steam, which has been accumulating above the water in the boiler, during the time of the descent of the piston, and is now issuing through the puppet-clack, as soon as the steam-cock is opened, rushes violently into the cylinder, having a greater elasticity than that of the air. It, therefore, immediately blows open the snifting-valve, through which it drives out the air that had been disengaged from the injection-water.

At the same time, the water which had been injected before, together with the condensed steam,

run out through the eduction-pipe,  $q$ , and, lifting up the valve,  $r$ , flow into the hot-well.

By the admission of the steam under the piston, the pressure of the atmosphere on the top is counterbalanced, and the piston is free to move upwards or downwards.

But the other end of the beam being broader, so as to be heavier than the piston, now raises it to the top of the cylinder, whence it is again forced downwards by the pressure of the atmosphere, as soon as the vacuum is formed under it by the admission of the injection-water. In this manner the operation is repeated; the piston, being forced down by the weight of the atmosphere, raises the other end of the beam with whatever is attached to it: and, on the other hand, when the pressure of the atmosphere is counterbalanced by the steam under the piston, the superior weight of the pump-end of the beam brings the piston up again.

Savary's was an engine that raised water by the pressure of steam; but Newcomen's raises water entirely by the pressure of the atmosphere; and the steam is employed merely as the most expeditious mode of producing a vacuum, into which the atmospherical pressure may impel the *first mover* of his machine.

Hence the great superiority of this latter engine. We have no need of steam of very great elasticity; and we operate by means of very moderate heats, and, consequently, with much smaller quantity of fuel. There are no bounds to the power of this machine; however deep a mine may be, a cylinder may be used of such dimensions, that the pressure of the air may exceed the weight of the column of water to be raised. The form of this machine also renders it applicable to almost every mechanical

purpose; because a skilful engineer can readily find a method of converting the reciprocating motion of the working-beam, into a motion of any kind which may suit his purpose. Savary's engine could not admit of such a general application, and seems almost restricted to raising water.

Inventions improve by degrees. The most exact and unremitting attention was at first required to open and shut the cocks precisely at the proper time; for neglect might be ruinous to the machine, by the confined steam beating out the bottom of the cylinder, or allowing the piston to be wholly drawn out of it. Stops were contrived to prevent these accidents; then strings were used to connect the handles of the cocks with the beam, so that they should be turned whenever it was in certain positions. These were gradually changed, and improved into detents and catches of different shapes; at last, Mr. Beighton simplified the whole of these subordinate movements.

About 1762, the late Mr. Watt began to turn his attention to this machine, which he has since brought to so great a degree of perfection.

But before we explain Mr. Watt's improvements, it is necessary to premise a short account of the imperfections of the old steam-engines, and their causes.

The pressure of the atmosphere, or any equivalent resistance, prevents the production of steam, until the water be heated to 212 degrees of Fahrenheit's thermometer; but when that pressure is removed, or the water be placed in a vessel exhausted of air, steam is produced from it when it is colder than the human blood. On the contrary, if water be pressed upon by air or steam, which

are more compressed than the atmosphere, a degree of heat above 212 degrees is necessary for the production of steam.

When the vacuum is produced by throwing cold water into the cylinder to condense the steam, that water becomes hot; and, being in a vessel partially exhausted, it produces a steam, which in part resists the pressure of the atmosphere upon the piston, and lessens the power of the engine. Another defect is the destruction of steam, which unavoidably happens upon attempting to fill a cold cylinder with it; for the injection-water, at the same time that it condenses the steam, not only cools the cylinder, but remains there until it be forced out at the eduction-pipe by the steam which is let in to fill the cylinder for the next stroke; and that steam will be condensed into water as fast as it enters, until all the parts it comes in contact with be nearly as hot as itself.

Watt preserved an uniform heat in the cylinder of his engines, by not suffering cold water to touch it, and by protecting it from the air or other cold bodies, by a surrounding case filled with the steam, or with hot air or water, and by coating it over with substances that transmit heat slowly. He made his vacuum more perfect, by condensing the steam in a separate vessel, called the *condenser*; which may be cooled at pleasure without cooling the cylinder, either by injection of cold water, or by surrounding the condenser with it; and generally by both. He extracted the injection-water and detached air from the cylinder or condenser, by pumps which were wrought by the engine itself.

As the inside of the cylinder was, in the old engine, exposed to the air at every stroke when the piston descended, and was thus considerably

cooled, he inclosed the top of the cylinder by a metal plate having a hole in it, through which the piston rod worked in a collar of leathers; and instead of employing the pressure of the atmosphere to force down the piston, he introduced the steam above the piston, when the vacuum is formed underneath, and employed it to produce this effect: thus making the direct pressure of the steam the moving power, as in the original construction of the engine.

The last great improvement made by Mr. Watt was his giving an impulse to the piston by the steam both in descending and ascending, instead of being impelled, as in the old engine, during the descent of the piston only.

We shall now proceed to describe one of Watt's engines on the latest construction.

A is the boiler, which is generally of an oblong form; and the flame, after striking on its concave bottom, circulates round the sides, and sometimes returns in a pipe through the body of the water, before it is suffered to go up into the chimney. In his engines, there are commonly two of these boilers, so that one of them may work while the other is repairing. B (Plate 11. fig. 1.), is the steam-pipe which conveys the steam to the cylinder C, which is cased, and closed at top by a plate, having a collar of leathers, through which the piston-rod D works. *a* and *c* are the steam-valves, through which the steam enters into the cylinder: it is admitted through *a*, when it is to press the piston downwards, and through *c* when it presses it upwards. *b* and *d* are the eduction-valves, through which the steam passes from the cylinder into the condenser *e*, which is a separate vessel, placed in a cistern of cold water, and which has a jet of cold water continually playing up in the in-



side of it.  $f$  is the air-pump, which extracts the air and water from the condenser. It is worked by the great beam or lever, and the water brought by it from the condenser, after being brought into the hot-well  $g$ , is pumped up again by the pump  $h$ , and is brought back again into the boiler by the pipe  $i$ .  $k$  is another pump, also worked by the engine itself, which supplies the cistern in which the condenser is placed, with cold water.

In the old engines, where the working-stroke was only downwards, the piston-rod was attached to the beam by chains, which bent round an arch on the end of the beam, in order to make the piston-rod move always in a perpendicular direction. This may be seen in the plate of Newcomen's engine. But in Mr. Watt's engines, where the working-stroke is doubled, that is, both upwards and downwards, chains could not answer this purpose, as, when the piston was forced upwards, they would slacken, and would not communicate the motion to the beam. It was necessary, therefore, that the piston-rod should be fastened to the beam by inflexible bars; but that the stroke might be perpendicular, a particular contrivance was invented by Mr. Watt, which is exhibited in Plate 11., and which answers the intended purpose admirably. It is usually called the parallel-joint; and its nature and construction will be easily understood from the figure. In order to make the engine itself open and shut the steam and eduction-valves, long levers are attached to them, which are moved by the piston-rod of the air-pump  $E F$ . This part of the apparatus is called the working-geer, and is so contrived, that the valves may be worked either by hand or by the perpendicular rod. By shutting these valves, the engine may be stopped in an instant.

In order to communicate a rotatory motion to any machinery by the motion of the beam of the steam-engine, Mr. Watt made use of a very large fly-wheel, G; on the axis of which is a small concentric-toothed wheel, H. A similar toothed-wheel, I, is fastened by straps to a rod coming from the end of the beam, so that it cannot turn round on its axis, but must rise and fall with the motion of the great beam.

A bar of iron connects the centres of these two small-toothed wheels, so that they cannot quit each other. When, therefore, the beam raises the wheel I, it must move round the circumference of the wheel H, and turn it together with the fly: and it will be evident, upon consideration, that the fly, driven in this manner, will make two revolutions for every one of the wheel I. This mode of moving the fly is preferable to a crank, as it goes with twice the velocity: it is called the *sun and planet-wheel*, from the resemblance of the motion to that of those luminaries.

The valves of this steam-engine are all *puppet-valves*, as these are found least liable to be out of order.

The mode of operation in Mr. Watt's engine is as follows:

Suppose the piston at the top of the cylinder, in the situation represented in the plate, and the lower part of the cylinder filled with steam. By means of the handle E, open the steam-valve *a*, and the eduction-valve *d*, the levers of which are connected together; there being now a communication between the cylinder and the condenser, the steam instantly rushes into the condenser, leaving the cylinder empty, whilst at the same time the steam from the boiler, entering by the

steam-valve *a*, presses upon the piston, and forces it down. As soon as the piston has arrived at the bottom, the steam-valve *c*, and the eduction-valve *b*, are opened, whilst the valves *a* and *d* are shut; the steam, therefore, immediately rushes through the eduction-valve *b* into the condenser, whilst the piston is forced up again by the steam, which is now admitted by the steam-valve *c*.

Fig. 2, which is a section of the steam-pipes, taken at right angles to that in Fig. 1, shows this more distinctly; *s* is the pipe which conveys the steam from the boiler; *a* and *c* are the steam-valves, and *b* and *d* the eduction-valves. By attending to the operation in both the sections, the reader will easily understand it. It appears at first a little confused, by there seeming to be only one steam-pipe for communicating between the cylinder and the condenser; but the difficulty is cleared up, by representing both the pipes, as in Fig. 2.

Fig. 3. is a longitudinal section of the boiler, representing the mode of supplying it with water, and the safety-valve and cocks. *f* is a small cistern, which is supplied with water from the hot-well, as represented in Fig. 1; from the bottom of this cistern, a pipe goes down almost to the bottom of the boiler, where it turns up a little, to prevent the entrance of the steam which rises from the bottom. From the side of this cistern is supported a small lever, to one end of which is fastened a wire that carries a stone which hangs in the water of the boiler; the other end of the lever supporting also by a wire a valve that shuts the top of the pipe that goes down from the cistern. Now, supposing the stone just at the surface of the water, and balanced by a weight at the opposite end of the lever; it is evident that, by the laws of hydro-

statics, already explained, a certain part of the weight of the stone will be supported by the water, so long as it continues immersed in it; but if a part of the water evaporate by boiling, a proportional part of the stone will be above the water, consequently the stone will bear more upon the lever, and raise the weight at the other end; but in raising that weight, it also opens the valve in the small cistern, and admits water until it stand at the same height in the boiler as before, and then the valve and the stone being again in equilibrio, the valve remains shut until a new quantity is evaporated. By this means the supply of water is very gradual, however, and not by fits and starts, as here described for the sake of illustration.

It is found by experience to be a much better method than a ball-cock; and the regular supplying of the boiler with water is of the first importance. As a check upon this, and to know perfectly the height of the water in the boiler, there are two cocks, *g* and *h*, one of which reaches nearly to the surface of the water when at its proper height, and the other enters a little below the surface.

It is evident, that if the water be at the just height, and you open *g*, that steam will issue; and if *h* be opened, water will be driven out by the pressure of the steam. But if water come out from *g*, then the water must be too high in the boiler; and if steam issue from *h*, then the water is too low. By this means, it is easy to know at all times the exact height of the water in the boiler.

*i* is a safety-valve, to prevent the bursting of the boiler by the steam growing too strong; *k* is the pipe which conveys the steam to the engine.

Fig. 47. is Mr. Cartwright's steam-engine, the construction of which evinces much ingenuity. *a* is the cylinder, which is supplied with steam from the boiler through the pipe *b*; *c* is the piston in the act of going up; *d* is the pipe that conducts the steam into the condenser *e*, which consists of two cylinders, one within the other, leaving a small space between them, into which the steam is admitted; while the inner cylinder is filled with cold water, and also the external cylinder surrounded by the same; so that, by this means, a very large surface of steam is exposed, though no water is suffered to come into actual contact with it.

To the bottom of the piston, *c*, is attached a rod, with another piston, *e*, working in the pipe *d*. When the piston *e* arrives at the bottom of the cylinder, a valve which is in the piston, is opened by its pressing against the bottom, and opens a communication with the condenser, whilst the spring *k*, fixed to the rod of the piston, shuts the valve which admits the steam from the boiler. The steam, therefore, being thus condensed, runs into the lower pipe *f*. The piston *e* arriving at the bottom of the pipe in which it works at the same time with *c*, presses upon the condensed water, shuts the valve *f*, and forces the water up the pipe *g*, into the box *h*. The air which is disengaged from the water rises to the top of the box, and, by its elasticity, forces the water through the pipe *i*, which carries it back again into the boiler. When the air accumulates in the box to such a degree as to depress the water, the ball-cock falls with it, and opens a valve in the top of the box, which suffers some of the air to escape.

When all the steam is condensed, the motion of the fly attached to the machine brings the piston

up again, its valve now remaining shut by its weight. On arriving at the top, it presses up the steam valve, which admits the steam from the boiler to force it down as before.

$l$  and  $m$  are two cranks, upon whose axes are two equal wheels working in each other, for the purpose of converting the perpendicular motion of the piston-rod into a rotatory motion, for working the machinery attached to it.

But the most valuable part of this engine is in the construction of the piston, which Mr. Cartwright made wholly of metal, and so as, by means of strings, to fit the cylinder very exactly. This not only saves the expence and trouble of packing, which must frequently be renewed in all other engines, but also saves a great deal of steam, on account of the more accurate fitting of the piston.

As it is evident from its construction that the whole of the steam is brought back again into the boiler, it affords the means of employing alcohol instead of water, and thus saving a great deal of fuel.

This machine seems to be peculiarly applicable to purposes requiring only a small power, as it is not expensive, and occupies little room.

The draining of deep mines requiring a very great power, steam heated to above the usual temperature of  $212^{\circ}$ , is sometimes employed in steam engines, and these are called *high pressure engines*. Several of these have been executed in Cornwall by Woolf and Trevethick. They are the most powerful of this class of engines which have been constructed, but they require extraordinary strength in the boilers, and great care with the safety valves, a neglect of which has occasioned dreadful explosions.

In describing the effects produced by steam engines, the work performed by a horse is generally made use of as a standard; accordingly we say an engine of 10, 20, 30, &c. horse power. A steam engine having a cylinder of 19 inches diameter, making 25 strokes of 4 feet per minute, and consuming 3700 pounds of coals per day, is equivalent in power to 20 horses. A cylinder of 24 inches, making 22 strokes of 5 feet, and burning 5500 pounds of coals, is equal to 20 horses.

### STEAM BOATS.

Among the numerous applications of steam is that of propelling vessels by it, without the aid of sails or oars.

It appears that, as long ago as 1736, one Jonathan Hulls, of London, took out a patent for a method of moving vessels on the water by machinery worked by a steam engine. But although several others since that time made several experiments with steam boats, yet Fulton was the first who succeeded in applying them on an extensive scale, which he did upon the great lakes in North America about 1808. In 1813, the steam boat was first introduced into this country upon the river Clyde.

The hull of the steam vessel is not very different in form from that of a ship constructed for sails, but has no rigging or upper works. About the middle of the vessel is fixed the boiler of the steam engine, which is made to work a wheel on each side of the vessel, nearly similar to the wheel of an undershot mill, by the action of which on the water the vessel is moved. The smoke from the boiler furnace is carried off by an iron flue of considerable

height, so as not to incommode the passengers. The vessel is directed in the usual manner by a rudder.

Some attempts have been made to place the water wheels, or paddles that drive the vessel, in the middle, instead of being on the sides, by which construction the steam vessel appears double, with the wheels between: and this idea promises some advantages. On the first employment of the steam engine for this purpose, several accidents happened from the bursting of the boilers, which were of *cast* iron. But since the boilers have been made of *wrought* iron, this danger is very much lessened; and it would appear that steam vessels are now quite as safe as any other mode of conveyance. The chief advantage is the certainty of the conveyance, as they do not depend upon wind or tide.



## OF SOUND.



WHEN an elastic body is struck, its parts are put into a tremulous or vibratory motion, which is communicated to the surrounding air. This vibration of the air, which may be compared to the waves in water, occasioned by a stone thrown into it, extends to the tympanum or drum of the ear, and affects the nerves with the sensation called sound.

Air is the usual vehicle of sound, but it is not absolutely essential; the vibration of a solid body being capable of affecting the ear without the intervention of air, as may be observed by striking a poker which is held by a string and pressed against the ear. It is necessary, however, that there be some substance extending from the sounding body to the ear, as sound cannot be conveyed through a vacuum. Saussure observed, that the noise of a pistol fired on the top of Mont Blanc, where the air is highly rarefied, was not greater than the report of a small cannon used as a toy. On the contrary, the noise of a bell, inclosed in a receiver of condensed air, is louder than before the air was condensed.

As sound is owing to the elasticity of bodies, the most elastic are the most sonorous: for example,

glass, as may be perceived in drawing a wet finger on the edge of a drinking glass.

The vibration of sonorous bodies may be easily seen in musical strings.

If the middle of a string which is fixed at both ends, A B, (Plate 25. fig. 6.) be drawn to one side, as to C, it will, when let loose, vibrate to D, and then will return back only to E, having lost something of the velocity which it had acquired during the first vibration, from the resistance of the air and friction: it will next move back to E, thus making every succeeding vibration less than the former one, till at last it ceases to vibrate.

The difference of musical tones depends on the different number of vibrations communicated to the air in a given time by the tremors of the sounding body; the quicker the succession of vibrations, the acuter is the tone; and the slower the vibrations, the graver the tone.

The vibrations of a musical chord grow less and less after it has been struck, and the sound consequently gradually diminishes; but it is a curious property, that notwithstanding this, the vibrations, whether great or small, are all performed in the same time. This is the reason why the same chord always gives the same note.

The number of the vibrations given in a certain time depends upon the length, size, and tension of the strings. This is very well illustrated in the violin.

The *harmony* or concord of two notes is owing to the vibrations of the air occasioned by them arriving at the ear at the same instant; and this may be the case, although their vibrations are different; for one may give two vibrations, while the other performs one only; this is the concord

called an octave. If one gives two while the other gives three, the harmony of a fifth is produced. In a fourth the vibrations are as three to four, &c.

All sounds arrive at the ear in the same time from sounding bodies equally distant, and sound travels through the air at the rate of 1130 feet in a second. This knowledge of the velocity of sound is of use in determining the distances of ships, or other objects: for instance, if a ship fires a gun, the motion of the light from the flash being almost instantaneous, the sound is not heard till some time after the flash is seen; then if 1130 feet be multiplied by the number of seconds between the sight of the flash and the sound, it will give the distance nearly.

Sounds may be heard in water, but faintly, though it travels through water much faster than through air.

Different musical sounds do not destroy each other, but may be heard together, the reason of which may be illustrated by observing, that the circular waves made in the water, by two stones thrown in at the same time, cross each other without disturbance.

When the aerial vibrations meet with an obstacle of a hard nature, they are reflected; and consequently, an ear placed in the course of these reflected waves, will perceive a sound similar to the original sound, but which will seem to proceed from a body situated in like position and distance behind the plane of reflection, as the real sounding body is before it. This reflected sound is called an *echo*.

The waves of sound being thus reflexible, nearly in the same manner as the rays of light, may be deflected or magnified by much the same contri-

vances as are used in optics. From this property of reflection, it happens that sounds uttered in one focus of an elliptical cavity are heard much magnified in the other focus.

Buildings constructed of certain shapes, and also mountains, have this property of reflecting sounds in a remarkable manner. The whispering gallery of St. Paul's is a well-known instance. At Keswick lake, the firing of a cannon is repeated from the mountains many times, so as to resemble the noise of a distant battle. At Woodstock park in Oxfordshire, an echo repeats seventeen times in the day, and twenty times in the night.

Sound is conveyed quicker through solid bodies than through the air. Hassenfratz found that when he struck with a hammer the top of a wall, the sound was heard double by a person at the bottom, one sound travelling through the wall, and the other more slowly through the air.

Sounds are conveyed to great distances through tubes, and upon this property is founded a very useful contrivance, called *acoustic* or *speaking tubes*, which are now fixed up in houses for the purpose of speaking from one story to another.

The *Invisible Girl*, with which the public was some time puzzled and amused, was constructed upon a principle nearly similar. This exhibition consisted of a hollow copper ball, to which was attached four trumpets, and which was suspended by ribbons from the four corners of a frame resembling a bed-post, and having no other connexion with the frame. The globe was supposed to contain the invisible being, as the voice apparently proceeds from the interior of it. If a question was asked by speaking into one of the trumpets, an answer was returned in a low female voice proceeding

from all the trumpets. This effect was produced by one of the standards of the frame being hollow, opening opposite the mouth of the trumpets, and communicating with a large case placed in an adjoining room, and containing the confederate.

Upon this principle also is constructed the *oracular bust*, which is made in this manner. Place a bust on a pedestal in the corner of a room, and let there be two tin tubes, one going from the mouth and the other from the ear of the bust, through the pedestal and floor, to an under apartment; there may likewise be wires that go from the under jaw and the eyes of the bust, by which they may be easily moved. A person being placed in the under room, and at a signal given, applying his ear to one of the tubes, will hear any question that is asked by another person above who speaks into the ear of the bust, and immediately reply; the sound will move through the tube, and seem to come from the mouth of the bust.

Contrivances such as these have been thought to be magical, by ignorant persons who were not in the secret.

The *speaking trumpet* is an instrument for conveying sounds to considerable distances. The form has sometimes been directed to be hyperbolic or parabolic, but it is found that a conical form succeeds better than any other.

The *hearing trumpet* is in form like the speaking trumpet, the vertex of the cone being placed to the ear.

## OPTICS.

LIGHT is generally considered as a peculiar species of matter which is emitted or sent off in rays from certain bodies, which hence are called luminous bodies.

Light appears to move with a velocity that is truly inconceivable. It arrives at the earth from the sun in seven or eight minutes, which is at the rate of 150,000 miles in a second. The light of a lamp is seen at the distance of several miles apparently at the same instant it is lighted, it being impossible to measure so minute a portion of time as that which it occupies in traversing this space. The particles of light must also be minute beyond human imagination, for otherwise, from their amazing velocity, they would impinge on bodies with great force, and our organs of vision would be destroyed by them.

If a lighted candle be set by night on an eminence, it may be seen all round at the distance of half a mile; wherefore, there is no place within a sphere of a mile in diameter, in which the eye can be placed, where it will not receive some rays from this small flame.

From the extreme minuteness of the particles of light it is, that they cross each other in all directions without the least apparent disturbance.

We can easily see, through a small pin-hole in a piece of paper, all the objects, such as the sky, trees, houses, &c. which we could without the paper. The light proceeding from these objects must pass at the same time through the hole in a great variety of directions, before they arrive at the eye: yet it does not appear that vision is disturbed by that means.

Light, whether it comes from the sun, a candle, or any other luminous body, moves always in straight lines only: of this we may be convinced from several simple observations. If a stick be placed upright before a lighted candle, the line extending from the top of the stick to the end of its shadow, will be a prolongation of that from the top of the stick to the candle. It is also impossible to see through a crooked tube.

When light proceeds in every direction from a luminous body, as the rays from a candle, its intensity is diminished as the square of the distance: that is, if you remove an object to twice the distance from the luminous body, it will be enlightened only one-fourth as much as before: if to three times the distance, it will be illuminated only one-ninth as much, and so on.

From certain circumstances in the texture of bodies which cannot yet be explained, some permit the rays of light to pass freely through them: such are called *transparent*: as glass, water, &c. while others entirely obstruct the light, and are called *opaque* bodies: as wood, metal, &c. A transparent or pellucid body is called also a *medium*, and light passing through them is said to be *transmitted*.

By a *ray* of light is meant the motion of a simple particle.

A *pencil of rays* is a number of rays diverging

or spreading out from a single point in the luminous body.

*Shadows* are occasioned merely by the obstruction of light by an opaque body.

#### OF REFRACTION.

If the rays of light, after passing through a medium, enter another of a different density, in a direction perpendicular to its surface, they proceed through this medium in the same direction as before. Thus, the ray  $F C$  (Plate 12. fig. 1.) proceeds to  $k$ , in the same direction.

But if they enter obliquely to the surface of a medium, either denser or rarer than what they moved in before, they are made to change their direction in passing through that medium.

If the medium which they enter be denser, they move through it in a direction nearer to the perpendicular drawn to its surface. Thus,  $B C$ , upon entering the denser medium  $L G$ , instead of proceeding in the same direction  $G H$ , is bent into the direction  $C I$ , which makes a less angle with the perpendicular  $C K$ .

On the contrary, when light passes out of a denser into a rarer medium, it moves in a direction farther from the perpendicular. Thus, if  $I C$  were a ray of light which had passed through the dense medium  $L G$ , on arriving at the rarer medium, it would move in the direction  $C B$ , which makes a greater angle with the perpendicular.

This refraction is greater or less, that is, the rays are more or less bent or turned aside from their course, as the second medium through which they pass is more or less dense than the first.



Thus, for instance, light is more refracted in passing from air into glass, than from air into water; glass being denser than water.

To prove the refraction of light, take an empty basin into a dark room; make a small hole in the window shutter, so that a beam of light may fall upon the bottom at *a* (Fig. 4.), where you may make a mark. Then fill the basin with water, without moving it out of its place, and you will see that the ray, instead of falling upon *a*, will fall at *b*.

If a piece of looking-glass be laid in the bottom of the basin, the light will be reflected from it, and will be observed to suffer the same refraction as in coming in; only in a contrary direction.

If the water be made a little muddy, by putting into it a few drops of milk, and if the room be filled with dust, the rays will be rendered much more visible.

The same may be proved by another experiment. Put a piece of money into the basin when empty, and walk back till you have just lost sight of the money, which will be hid by the edge of the basin. Then pour water into the basin, and you will see the money distinctly, though you look at it exactly from the same spot as before.

If the rays of light fall upon a piece of flat glass, as *L G* (Fig. 1.), they are refracted into a direction nearer to the perpendicular, as described above, while they pass through the glass; but after coming again into air, they are refracted as much in the contrary direction; so that they move exactly parallel to what they did before entering the glass. But, on account of the thinness of the glass, this deviation is generally overlooked, and it is considered as passing directly through the glass.

The cause of this refraction, or altering of the direction of the rays, may be owing to the superior attraction of the denser medium, which acts only at a very small distance; on the contrary, when light passes from a denser to a rarer medium, it is most strongly attracted by that which it leaves.

It is owing to the refraction of light by the atmosphere, that we see the sun and stars before they are actually above the horizon, and also after they are below it. Let  $A B C$  (Plate 25. fig. 7.) represent a portion of the earth's surface, and  $D E F$  the atmosphere surrounding it,  $G$  the place of the sun, and  $B E$  the horizon of the point  $B$ . A ray,  $G E$ , from the sun while still below the horizon, will be refracted upon its coming into the atmosphere, so as to arrive at the point  $B$ ; and, therefore, to an eye placed at  $B$ , the sun will appear at  $H$  on the horizon. And for the same reason, the image of the sun will be seen after he is actually set. Astronomers, in their calculations of the places of the heavenly bodies, are obliged to make allowances for this refraction.

When a ray of light,  $C D E F$ , (Plate 25. fig. 8.) passes through a piece of glass, the sides of which are parallel, as  $A B$ , it suffers two refractions, which destroy each, and the ray moves on in the same direction as at first. It is first refracted in the direction  $D F$ , and on leaving the glass again, into the direction  $E F$ , which is parallel to  $C D$ .

If parallel rays,  $a b$  (Plate 12. fig. 5.), fall upon a plano-convex lens,  $c d$ , they will be so refracted, as to unite in a point,  $c$ , behind it; and this point is called the *principal focus*, or the *focus of parallel rays*; the distance of which from the middle of the glass is called the *focal distance*, which is equal

to twice the radius of the sphere, of which the lens is a portion.

When parallel rays, as  $A B$  (Fig. 6.) fall upon a double convex lens, they will be refracted, so as to meet in a focus, whose distance is equal to the radius, or semi-diameter of the sphere of the lens.

But if a lens be more convex on one side than on the other, the rule for finding the focal distance is this: as the sum of the semi-diameters of both convexities is to the semi-diameter of either, so is double the semi-diameter of the other to the distance of the focus; or, divide the double product of the radii by their sums, and the quotient will be the distance sought.

If another glass,  $F G$ , of the same convexity as  $D E$ , be placed in the rays at the same distance from the focus, it will refract them so as that, after going out of it, they will be all parallel, as  $b c$ ; and go on in the same manner as they came to the first glass  $D E$ , but on the contrary sides of the middle ray.

The rays diverge from any radiant point, as from a principal focus; therefore, if a candle be placed at  $f$ , in the focus of the convex-glass  $F G$ , the diverging rays in the space  $F f G$ , will be so refracted by the glass, that, after going out of it, they will become parallel, as shown in the space  $c b$ .

If the candle be placed nearer the glass than its focal distance, the rays will diverge after passing through the glass, more or less, as the candle is more or less distant from the focus.

If the candle be placed farther from the glass than its focal distance, the rays will converge after passing through the glass, and meet in a point, which will be more or less distant from the glass,

as the candle is nearer to, or farther from, its focus; and where the rays meet, they will form an inverted image of the flame of the candle; which may be seen on a paper placed in the meeting of the rays.

Hence, if any object,  $A B C$  (Fig. 7.) be placed beyond the focus  $F$  of the convex glass,  $d e f$ , some of the rays which flow from every point of the object, on the side next the glass, will fall upon it, and after passing through it, they will be converged into as many points on the opposite side of the glass, where the image of every point will be formed, and consequently the image of the whole object, which will be inverted. Thus, the rays  $A d$ ,  $A e$ ,  $A f$ , flowing from the point  $A$ , will converge in the space  $d a f$ , and by meeting at  $a$ , will there form the image of the point  $A$ . The rays  $B d$ ,  $B e$ ,  $B f$ , flowing from the point  $B$ , will be united at  $b$ , by the refraction of the glass, and will there form the image of the point  $B$ . And the rays  $C d$ ,  $C e$ ,  $C f$ , flowing from the point  $C$ , will be united at  $c$ , where they will form the image of the point  $C$ . And so of all the intermediate points between  $A$  and  $C$ .

If the object  $A B C$  be brought nearer to the glass, the picture  $a b c$  will be removed to a greater distance; for then, more rays flowing from every single point, will fall more diverging upon the glass; and therefore cannot be so soon collected into the corresponding points behind it. Consequently, if the distance of the object  $A B C$  (Fig. 8.) be equal to the distance  $e B$  of the focus of the glass, the rays of each pencil will be so refracted by passing through the glass, that they will go out of it parallel to each other: as  $d I$ ,  $e H$ ,  $f h$ , from the point  $C$ ;  $d G$ ,  $e K$ ,  $f D$ , from the point  $B$ ;

and  $d$  K,  $e$  E,  $f$  L, from the point A; and therefore there will be no picture formed behind the glass.

If the focal distance of the glass, and the distance of the object from the glass, be known, the distance of the picture from the glass may be found by this rule; viz. multiply the distance of the focus by the distance of the object, and divide the product by their difference; the quotient will be the distance of the picture.

The picture will be as much larger, or less than the object, as its distance from the glass is greater or less than the distance of the object; for as B  $e$  is to  $e b$ , so is A C to  $c a$ ; so that if A B C be the object,  $c b a$  will be the picture; or if  $c b a$  be the object, A B C will be the picture.

If rays converge before they enter a convex lens, they are collected at a point nearer to the lens than the focus of parallel rays. If they diverge before they enter the lens, they are then collected in a point beyond the focus of parallel rays; unless they proceed from a point on the other side at the same distance with the focus of parallel rays; in which case they are rendered parallel.

If they proceed from a point nearer than that, they diverge afterwards, but in a less degree than before they entered the lens.

When parallel rays, as  $a b c d e$  (Plate 13. fig. 1.), pass through a concave lens, as A B, they will diverge after passing through the glass, as if they had come from a radiant point C, in the centre of the convexity of the glass; which point is called *virtual* or *imaginary focus*.

Thus, the ray  $a$ , after passing through the glass A B, will go on in the direction  $k l$ , as if it had proceeded from the point C, and no glass been in

the way. The ray  $b$  will go on in the direction  $mn$ ; the ray  $c$  in the direction  $op$ , &c. The ray  $C$ , that falls directly upon the middle of the glass, suffers no refraction in passing through it; but goes on in the same rectilinear direction, as if no glass had been in the way.

If the glass had been concave only on one side, and the other side quite flat, the rays would have diverged after passing through it, as if they had come from a radiant point at double the distance of  $C$  from the glass; that is, as if the radiant point had been at the distance of a whole diameter of the glass's convexity.

If rays come more converging to such a glass, than parallel rays diverge after passing through it, they will continue to converge after passing through it; but will not meet so soon as if no glass had been in the way; and will incline towards the same side to which they would have diverged, if they had come parallel to the glass.

Since all the rays of the sun which pass through a convex glass are collected together in its focus, the force of all their heat is collected into that part. Hence, we see the reason why a convex glass causes the sun's rays to burn after passing through it.

Every lens, whether convex or plano-convex, will collect by refraction the rays of the sun dispersed over its surface into a point, and thus become a *burning lens*.

As all the rays which fall upon the lens are united in its focus, their effect ought to be so much the more, as the surface of the lens exceeds that of the focus. Thus, if a lens four inches broad collect the sun's rays into a focus at the distance of one foot, the image will not be more than one-

tenth of an inch broad. The surface of this little circle is 1600 times less than the surface of the lens, and consequently, the sun's rays must be ten times denser within that circle; it is not, therefore, surprising, that it burns with a degree of ardour and violence exceeding any culinary fire.

The most considerable of these glasses are those which were made by M. Tschirnhausen and Mr. Parker. The diameter of that of Tschirnhausen was three feet, the focus was formed at twelve feet, and its diameter one inch and a half, and weighed 160 pounds. To render the focus more vivid, it was collected a second time by a lens placed parallel to the first, and so situated, that the diameter of the cone of rays formed by the first lens was exactly equal to the diameter of the second lens, so that it received all the rays; the focus was contracted to eight lines, and its force was increased proportionally.

The lens made by Mr. Parker was formed of flint-glass three feet diameter, and when fixed in its frame, exposed a clear surface of two feet eight inches and a half in diameter; weight, 212 pounds; focal length, six feet eight inches; diameter of the focus, one inch. A second lens was used, which reduced the focus to half an inch.

Some of the principal effects produced by these glasses were as follows :

1. Every kind of wood took fire in an instant, whether hard or green, or soaked in water.
2. Iron plates grew hot in a moment, and then melted.
3. Tiles, slates, and all manner of earth, became red, and vitrified.
4. Sulphur, pitch, and all resinous bodies, melted under water.

5. Fir-wood exposed to the focus under water did not seem changed, but when broken, the inside was burnt to coal.

6. If a cavity was made in a piece of charcoal, and the substances to be acted on were put in it, the effect of the lens was much increased.

7. Any metal thus enclosed in the cavity of a piece of charcoal melted instantly, the fire sparkling like that of a forge.

8. The ashes of wood, paper, linen, and all vegetable substances were turned into a transparent glass.

9. The substances most difficult to be wrought on were those of a white colour.

10. All metals vitrified on a China plate, when it was so thick as not to melt, and the heat was gradually communicated.

11. When copper was thus melted, and thrown quickly in cold water, it produced so violent a shock, as broke the strongest earthen vessels, and the copper was entirely dissipated.

Though the heat of the focus was so intense as to melt gold in a few seconds, yet there was no heat at a small distance therefrom; and the finger might be placed in the cone of rays within an inch of the focus, without receiving any hurt.

Mr. Parker had the curiosity to try what the sensation of burning at the focus was; and having put his finger there for that purpose, he says, it neither seemed like the burning of a fire, nor a candle, but the sensation was that of a sharp cut with a lancet.

By means of an ordinary burning glass, a piece of wood may be charred or burnt to a coal, in a decanter of water, and yet the sides of the decanter, through which the rays pass so very near the focus, will not



be cracked, nor any ways affected; nor will the water be in the least degree warmed. If the wood be taken out, and the rays thrown on the water, no continuance of collected rays in this way will either heat the water or crack the glass; but if a piece of metal be put into the water, it soon becomes too hot to be touched, and communicating its heat to the water, makes it not only warm, but sometimes causes it to boil.

Though water alone be not affected, yet, if a little ink is thrown into it, the water will soon be heated.

*To find the focal Distance of Lenses by Experiment.*

1. When the focal length of the lens does not exceed two or three feet, it may be found by holding the lens at such a distance from the wainscot, opposite a window-sash, that the image of the sash may be distinct upon the wainscot; and this distance may be considered as the focal length of the lens; but if the focal length is long, you must compute the focus by the subsequent rule.

Measure the distance between the lens and the object, and also from the image: multiply these distances together, and divide the product by their sum; the quotient will give the focal distance; or, the square of the distance of the observed focus, divided by the distance of the object from the image, will give the excess of the observed focus beyond the true focal distance.

2. To find the focus by making a candle the object.

To do this, move the lens on the candle, and the paper for receiving its image, so that when

the image is most distant the lens may be exactly between the other two; then halve the distance between the object or its image, and the lens is the focal distance.

3. If a small hole, about one-fourth, or one-eighth of an inch, be made in the window-shutter of a darkened room, and a lens and piece of paper be held behind this hole, at proper distances, the place where the image of the hole is most distinct may be determined very exactly, and from them the focal length may be found by the foregoing rule.

4. By the sun's image. Place the lens, so that its axis may point as near as possible to the sun; then holding a paper opposite thereto, the burning point, or where the image of the sun is smallest, and the limb most distinct, is the focus. This method is sufficiently accurate for spectacle-glasses, and reading-glasses, and such as are broad in proportion to their focal length; but will not answer for lenses of a long focus, unless they are sufficiently long to exhibit the solar spots; because in these cases, the image is only a glare of light, without distinctness; but the inconveniences may be removed by the following method:

5. Cover the lens with a piece of pasteboard or paper, and make two round holes therein, at an equal distance from the edge of the lens, and on one of its diameters. The lens being thus covered, point its axis to the sun: now if a paper be held behind the lens, you will find the two circles, or white spots produced by the two holes, gradually approach nearer to each other, as the paper is moved further; at last they will coincide; and if the paper be moved still further, they will again separate. The distance of the paper from the

glass, when the circles unite being measured, gives the focal distance.

To find the focal length of a concave lens :

Let the lens be covered with paper, having two small circular holes : and on the paper for receiving the light, describe also two small circles, but with the centres at twice the distance from each other of the centres of the circles. Then move the paper forwards and backwards, till the middle of the sun's light, coming through the holes, falls exactly on the middle of the circles : that distance of the paper from the lens will be the focal length required.

To find the focus of a plano-convex, and a plano-concave lens :

By similar experiments you will find, 1. That the focus of a plano-convex, or of a plano-concave glass, is equal to a diameter of its convex or concave surface, that is, of the whole sphere it belongs to. 2. That the focal distance of a double convex, or double concave glass of equal convexities or concavities, is equal to a semi-diameter of either of its surfaces ; and, consequently, that the focal distance of a glass, of unequal convexities or concavities, will have an intermediate length between a diameter and a semi-diameter, of that surface which is most convex or concave.

To measure the focal distance of a globe of water, and of glass :

Take a hollow globe of glass, or, instead of it, a thin round flask, or decanter, and making a round hole, about an inch diameter, in a piece of brown paper, paste it on one side of the body of the decanter ; and having filled it with water, hold the covered side to the sun, that the perpendicular

rays may pass through the middle of the water, and the emergent rays will be collected to a focus, whose nearest distance from the decanter will be equal to the semi-diameter of the body of it, as will appear by receiving the rays upon a paper held at that distance. That this effect is owing to the water, and not to the glass, will be evident by emptying the decanter; for the light that then passes through the hole, will be as broad as the hole itself, at all the distances of the paper from the decanter.

If a similar experiment be tried with a solid globe or ball of glass, the distance of the focus from the nearest part of the ball will be one quarter of its diameter.

To find the vertex or centre of a lens :

Hold the lens at a proper distance from the eye, and observe the two reflected images of a candle made by the two surfaces. Move the lens till these images coincide, and that point is the vertex; and if this be in the middle of its surface, the glass is truly centered.

Whatever be the shape and magnitude of the hole in the paper that covers part of a lens, the shape and magnitude of the image will be the same as when the lens is uncovered; because any small part of a pencil of rays has the same focus as the whole; but the brightness will be diminished, in proportion as the hole in the cover is diminished; because the quantity of light which illuminates every point of a picture is diminished in that proportion.

*Of the different Refrangibility of the Rays of Light.*

Hitherto, in treating of the refraction of light, we supposed that all the particles of light, in passing out of one medium into another of different density, are equally refracted. This was the opinion of philosophers before the time of Sir Isaac Newton; but that indefatigable investigator discovered that light is not a simple homogeneous body, but is compounded of different species; and that each species is disposed both to suffer a different degree of refrangibility, in passing out of one medium into another, and to excite in our mind the idea of a different colour from the rest; and that bodies appear of that colour which they are most disposed to reflect.

To show this, let a room be darkened, and let a beam of light, B, (Plate 26. fig. 1.) be permitted to shine into it through a small hole in the window-shutter, and be made to fall upon a glass prism, A; then will the sun's rays, in passing through it, suffer different degrees of refraction, and by that means be parted into different rays, which being received upon a sheet of white paper will exhibit the following colours; viz. *red, orange, yellow, green, blue, indigo, and violet*; and if the whole *spectrum*, or image, C D, be divided into 360 equal parts, the red will occupy 45 of them, the orange 27, the yellow 48, the green 60, the blue 60, the indigo 40, and the violet 80.

As a ray of the sun may be separated into these seven primitive colours, so, by their mixture again, may white be produced.

For if the rays, after being separated in this manner by the prism, are made to fall upon a convex lens G, Fig. 2., they will converge at H, forming a spot of white light as at first. The same may also be shown by fixing pieces of cloth of all the seven colours, on the rim of a wheel, and whirling it round with great velocity; they will appear white. White, therefore, is the mixture of all the colours, as black is the want or deprivation of colour.

Though seven different colours are distinguishable in the prismatic spectrum, yet all these, as well as all other broken colours, can be composed by mixing together pigments of three colours only, viz. *red*, *blue*, and *yellow*; and, perhaps, in nature, there may be only those three, although as yet no experiments have been able to reduce the spectrum to three only: the orange being produced by the mixture of red and yellow; green, by mixing blue and yellow; and violet, or purple, from blue and red.

The instance of the separation of the primary colours of light which seems most remarkable, is that of the *rainbow*. It is formed, in general, by the reflection of the rays of the sun's light from the drops of falling rain, though frequently it appears among the waves of the sea, whose heads or tops are blown by the wind into small drops, and it is sometimes seen on the ground, when the sun shines on a very thick dew. Cascades and fountains, whose waters are in their fall divided into drops, exhibit rainbows to a spectator, if properly situated during the time of the sun's shining; and water blown violently from the mouth of an observer, whose back is turned towards the sun, never fails to produce the same phenomenon.

This appearance is also seen by moon light, though seldom vivid enough to render the colours very distinguishable; and the artificial rainbow may be produced even by candle-light, on the water which is ejected by a small fountain, or *jet d'eau*. All these are of the same nature, and dependent on the same causes, viz. the various refrangibility of the rays of light.

The colours observable on soap-bubbles, and the halos which sometimes surround the moon, are also referable to the same origin.

This unequal refraction of the rays of light proves a great inconvenience in the construction of single lenses, as the images formed by them have always coloured rays round them, owing to the separation of the coloured rays at the extremities of the lens. This has given rise to a very ingenious construction of a lens, compounded of three others fitted together, and made of glass having different degrees of refrangibility, so that the refractive power of one lens shall correct that of the other, and thus produce an image free from the colours occasioned by common lenses; these compound lenses are called *achromatic* glasses, and are usually composed of two concave lenses of crown-glass, with a concave lens of flint-glass between them. These were invented by Dollond, and are now used in all the best telescopes.

#### *Description of the Eye, and the Nature of Vision.*

In order to understand the science of vision, it is necessary, first, to describe the organ of sight.

The eye is placed in a bony cavity called the orbit, which is lined with fat, to form a soft bed

for it to rest upon, and facilitate its various movements.

The eye-brows defend the eye from the light when it is too strong, and prevent their being incommoded by any substances that might slide down the forehead, and thence fall into the eyes.

The eye-lids, like two substantial curtains, protect and cover the eyes when we are asleep; when we are awake, they diffuse by their motion, and by peculiar secreting organs, a fluid over the eye, which cleans and polishes it, and thus renders it fitter for transmitting the rays of light.

That the eye-lids may shut with greater exactness, and not fall into wrinkles when they are elevated or depressed, each edge is stiffened by a cartilaginous arch. The eye-lashes, like two pallisades of short hair, proceed from these cartilaginous edges, warning the eye of danger, protecting it from straggling motes, and warding off the wandering fly.

The eye itself is of a globular form, but more protuberant on the fore-part than behind.

It is composed of three coats, or teguments, one covering the other, and inclosing three different substances, called humours.

A B C D (Plate 13. fig. 4.) is a section of the globe of the eye, the three concentric circles representing the three coats.

The external coat, or membrane, is called the *sclerotica*; it is strong, elastic, and of a white colour, resembling parchment: the hinder part is very thick and opaque, but it grows gradually thinner, as it advances towards the part where the white of the eye terminates. A circular portion of it in front is perfectly transparent, and more



convex than the rest: this is called the *cornea*, as C D.

Immediately adherent to the sclerotica within, is the *choroides*, which is a soft and tender coat, composed of a multitude of vessels. This membrane is inwardly of a russet-brown colour, almost black. Like the sclerotica, it is distinguished into two parts; the fore-part being called the *iris*, while the hinder-part retains the name of *choroides*. The fore-part commences at the place where the cornea begins: it here attaches itself more strongly to the sclerotica by a cellular substance, forming a kind of white narrow circular rim, called the *ciliary circle*. The *choroides* separates at this place from the sclerotica, changing its direction, turning, or rather folding directly inwards towards the axis of the eye, cutting the eye, as it were, transversely. This part, called the *iris*, is composed of two kinds of muscular fibres; the one sort tending, like radii, towards the centre of the circle, and the other forming a number of concentric circles round the same centre. The central part of the *iris* is perforated, and the orifice, which is called the *pupil*, is varied in magnitude by the action of the two sets of fibres composing the *iris*. When a very luminous object is viewed, the circular fibres contract, and diminish the orifice; and, on the other hand, when the objects are dark and obscure, the radial fibres of the *iris* contract, and enlarge the pupil so as to admit a greater quantity of light. The *iris* is differently coloured in different persons: in some it is blue, in others brown, or of a hazel colour.

The whole of the *choroides* is opaque, by which means no light is allowed to enter into the eye, but what passes through the pupil. To render this opacity more perfect, and the chamber of the eye

still darker, the posterior surface of this membrane is covered all over with a black mucus, called the *pigmentum nigrum*.

From the part of the choroides, called the ciliary circle, arise a set of radial fibres, turning inwards towards the centre of the eye, and filled up between with a black mucus, giving it the appearance of a membrane, as *C a*, *D b*. This serves to support the crystalline humour, to be described afterwards; and is called the *ligamentum ciliare*, or ciliary ligament.

The third and last membrane of the eye is called the *retina*. This is a fine and delicate membrane, being an expansion of the medullary part of the optic nerve. It is spread like a net all over the concave surface of the choroides, and terminates at the ciliary ligament. It serves to receive the images of objects produced by the refraction of the different humours of the eye, and painted, as it were, upon its surface. It is itself transparent, but appears black, by reason of the *pigmentum nigrum* spread underneath it. From the hinder part of the eye (but not from the central part), proceeds the *optic nerve A*, which conveys to the brain the sensation produced upon the retina.

The coats of the eye which invest and support each other after the manner of the concentric coats of an onion, or other bulbous root, inclose three transparent bodies, called the *aqueous*, *crystalline*, and *vitreous humours*.

The aqueous humour is the most fluid, being thin and clear like water: it fills up the space between the cornea and ciliary ligament, being divided into two portions by the iris, which swims in it. These are called the anterior and posterior portions of the aqueous humour.

The second humour of the eye is the crystalline, which is as transparent as the purest crystal; but in consistence like a hard jelly, growing somewhat softer from the middle towards the edges. Its form is that of a double convex lens, but more convex on the interior than on the exterior surface. This humour is contained in a very strong and transparent membrane, called the *arachnoides*, and is suspended behind the aqueous humour by the ligamentum ciliare.

The *vitreous* is the third humour of the eye: it receives its name, like the others, from its appearance, which is like melted glass. It is not so hard as the crystalline, nor so liquid as the aqueous humour. It fills all the interior chamber of the eye, behind the crystalline humour.

As every point of an object,  $A B C$ , (Plate 13. fig. 6.) sends out rays in all directions, some rays from every point on the side next the eye will fall upon the cornea, between  $E$  and  $F$ ; and by passing on through the humours and pupil of the eye, they will be converged to as many points on the retina, or bottom of the eye, and will thereon form a distinct inverted picture,  $c b a$ , of the object. Thus the pencil of rays,  $q r s$ , that flows from the point  $A$  of the object, will be converged to the point  $a$  on the retina; those from the point  $B$  will be converged to the point  $b$ ; those from the point  $C$  will be converged to the point  $c$ ; and so of all the intermediate points, by which means the whole image  $a b c$  is formed, and the object made visible; although it must be owned, that the method by which this sensation is carried from the eye by the optic nerve to the common sensorium in the brain, is above the reach of our conception.

But that vision is effected in this manner may be demonstrated experimentally. Take a bullock's eye while it is fresh, and having cut off the three coats from the back part, quite to the vitreous humour, put a piece of white paper over that part and hold the eye towards any bright object, and you will see an inverted picture of the object upon the paper.

Since the image is inverted, many have wondered why the object appears upright. But we are to consider, 1. That inverted is only a relative term; and, 2. That there is a very great difference between the real object and the means or image by which we perceive it. When all the parts of a distant prospect are painted upon the retina, they are all right with respect to one another, as well as the parts of the prospect itself; and we can only judge of an object's being inverted, when it is turned reverse to its natural position, with respect to other objects which we see and compare it with. If we lay hold of an upright stick in the dark, we can tell which is the upper or lower part of it, by moving our hand upward or downward; and know very well that we cannot feel the upper end by moving our hand downward. Just so we find by experience, that upon directing our eyes towards a tall object, we cannot see its top by turning our eyes downward, nor its foot by turning our eyes upward; but must trace the object the same way by the eye to see it from head to foot, as we do by the hand to feel it; and as the judgment is informed by the motion of the hand in one case, so it is also by the motion of the eye in the other.

The diameters of images at the bottom of the eye are proportional to the angles which the objects subtend at the eye, the same as in a lens;

and are reciprocally as the distances of the same object viewed in different places.

The eye is in reality no more than a camera obscura; for the rays of light flowing from all the points of an object, through the pupil of the eye, do by the refraction of its humours, paint the image of it in the bottom of the eye: just so it is in the camera obscura, where all the rays refracted by a lens in the window-shutter, or passing through a small hole in it, paint the image on the opposite wall.

The eye can only see a very small part of an object distinctly at once. For the collateral parts of an object are not represented distinctly in the eye, and therefore the eye is forced to turn itself successively to the several parts of the object it wants to view, that they may fall near the axis of the eye, where alone distinct vision is performed.

When any point of an object is seen distinctly with both eyes, the axes of both eyes are directed to that point, and meet there; and then the object appears single, though looked at with both eyes; for the optic nerves are so framed, that the correspondent parts in both eyes lead to the same place in the brain, and give but one sensation; and the image will be twice as bright with both eyes as with one. But if the axes of both eyes be not directed to the object, that object will appear double, as the pictures in the two eyes do not fall upon correspondent or similar parts of the retina.

The best eye can hardly distinguish any object that subtends at the eye an angle less than half a minute; and very few can distinguish it when it subtends a minute.

Though men may see distinctly at different distances, by altering the position and figure of the

crystalline humour, yet they can only see distinctly within certain limits; and nearer than that, objects appear confused. But these limits are not the same in different people. A good eye can see distinctly when the rays fall parallel upon it; and then the principal focus is at the bottom of the eye.

A man can judge of a small distance with a single eye, by frequently observing how much variation is made in the eye to make the object distinct; and from this a habit of judging is acquired. But this cannot be done at great distances, because, though the distance be varied, the change in the eye becomes then insensible.

But one can judge of greater distances with both eyes, than with one. For the eyes being at a distance from one another, as long as that distance has a sensible proportion to the distance of the object, one gets a habit of judging, by the position of the axes of the eyes, which are always directed to that point. For different distances require different positions of the axis, which depend on the motions of the eyes, which we feel. But in very great distances, no judgment can be made from the motion of the eyes, or their internal parts. Therefore we can only guess at the distances from the magnitude, colour, and the position of interjacent bodies.

Whatever light falls upon that part of the retina where the optic nerve, D, springs, makes no impression; and therefore, if the picture of an object falls thereon, it is not perceived, and that object is invisible. This will appear by placing a small bright object before you, and looking at it with one eye; then moving one eye laterally towards the contrary side, (towards the left, if it be the

right eye,) the object will disappear, and seem to be lost; and moving it still farther, it will appear again. Now this place is not at the bottom of the eye, but nearer the nose in both of them; so that no rays, either parallel or diverging, that come from any object, can fall upon that place in both the eyes; and any object we direct the eyes to, will always be visible, at least to one eye. But the same bright object may be made to disappear to both eyes, by directing the axis of both eyes to a point a little beyond the nose, to be found by trials.

Dimness of sight generally attends old people; and this may arise from two causes: 1. by the eyes growing flat, and not uniting the rays at the retina, which causes indistinctness of vision; or 2. by the opacity of the humours of the eye, which in time lose their transparency in some degree; from whence it follows, that a great deal of the light that enters the eye is stopped and lost; and every object appears faint and dim.

As the rays of light flowing from an object, and painting its image upon the retina, are the immediate causes of seeing; so where there is no light, there can be no vision: consequently, without light, the eye becomes a machine utterly useless.

#### OF SPECTACLES.

We explained before, that if objects are seen through a perfectly flat glass, the rays of light pass through it, and from them to the eye, in a straight direction, and parallel to each other; and, consequently, the objects appear very little either diminished or enlarged, or nearer, or farther off, than to the naked eye; but if the glass they are seen through have any degree of convexity, the rays of

light are directed from the circumference towards the centre, in an angle proportional to the convexity of the glass, and meet in a point, at a greater or lesser distance from the glass, as it is more or less convex. This point, where the rays meet, is called the focus; and this focus is nearer or farther off, according to the convexity of the glass; for as a little convexity throws it to a considerable distance, so when the convexity is much, the focus is very near. Its magnifying power is also in the same proportion to the convexity; for as a flat glass scarcely magnifies at all, the less a glass departs from flatness, the less of course it magnifies; and the more it approaches towards a globular figure, the nearer its focus is, and the more its magnifying power.

People's different length of sight depends on the same principle, and arises from more or less convexity of the cornea and crystalline humour of the eye: the rounder these are, the nearer will the focus or point of meeting rays be, and the nearer an object must be brought to see it well. The case of short-sighted people is only an over-roundness of the eye, which makes a very near focus; and that of old people is a sinking or flattening of the eye, whereby the focus is thrown to a great distance; so that the former may properly be called eyes of too short, and the latter eyes of too long a focus. Hence, too, the remedy for the last is a convex glass, to supply the want of convexity in the eye itself, and brings the rays to a shorter focus; whereas a concave glass is necessary for the first, to prevent the rays from coming to a point too soon.

Nothing is more common, than to observe old people holding objects they would examine at a



great distance from them, for the reason above-mentioned; and every body knows, short-sighted people cannot distinguish any thing without bringing it very near their eyes. Short-sighted persons can distinguish much smaller objects than long-sighted people; for the object is magnified in proportion to the roundness of the eye and the nearness of the focus, and, consequently, appears four times as big to an eye whose focus is but four inches off, as it does to one whose focal distance is at eight inches. Short-sighted people have also this farther advantage, that age improves their eyes, by the same means it impairs that of others, that is, by making them more flat.

The nearer any object can be brought to the eye, the larger will be the angle under which it appears, and the more it will be magnified. Now, that distance from the naked eye, where the generality of people are supposed to see small objects best, is at about six inches; consequently, when such objects are brought nearer than six inches, they will become less distinct; and if to four, or three, they will scarce be seen at all. But by the help of convex glasses, we are enabled to view things clearly at much shorter distances than these; for the nature of a convex lens is to render an object distinctly visible to the eye at the distance of its focus; wherefore, the smaller a lens is, and the more its convexity, the nearer is its focus, and the more its magnifying power.

Now, it is evident from the figure, that if either the cornea  $C b D$  (Fig. 5.) or crystalline humour  $a b$ , or both of them, be too flat, their focus will not be on the retina, as at  $d$ , where it ought to be in order to render vision distinct; but beyond the eye, as at  $f$ . Consequently those rays which flow

from the object *C*, and pass through the humours of the eye, are not converged enough to unite at *d*; and therefore the observer can have but a very indistinct view of the object. This is remedied by placing a concave glass, *g h*, of a proper focus, before the eye; which makes the rays converge sooner, and imprints the image duly on the retina at *d*.

If either the cornea or crystalline humour, or both of them, be too convex, the rays that enter in from the object *C* (Fig. 4.) will be converged to a focus in the vitreous humour, as at *f*, and by diverging from thence to the retina, will form a very confused image thereon; and so, of course, the observer will have as confused a view of the object, as if his eye had been too flat. This inconvenience is remedied by placing a concave glass, *g h*, before the eye; which glass, by causing the rays to diverge between it and the eye, lengthens the focal distance, so that if the glass be properly chosen, the rays will unite at the retina, and form a distinct picture of the object upon it.

When glasses are put in frames for spectacles, their frames ought not to be straight, so as both eyes may be as the same plane; but they ought to be so bent in the middle, that the axis of both glasses may be directed to one point, at such a distance as you generally look with spectacles. By this means the eyes will fall perpendicular upon both glasses, and make the object appear distinct. But if they fall obliquely upon the glasses, it will cause a confused appearance in the objects; therefore the shape of the frame ought to be as represented (Fig. 7.) when *A B* is the plane as one glass is fixed, and *C D* the other.

## OF REFLECTION.

When the rays of light strike upon an opaque body, a part of them is *reflected*, or made to rebound in the same manner as a boy's marble does when thrown upon a stone pavement; but the whole of the rays is not reflected, a certain part being retained or absorbed by the opaque body.

It is a fundamental law in the reflection of the rays of light, as well as of all other elastic bodies, that the angle at which they rebound or are *reflected* from the surface of the reflecting body, is the same as that with which they *impinge* upon it.

Thus let  $F C$  (Plate 12. fig. 1.) be a ray of light falling perpendicularly upon the surface  $L G$ ; it will be reflected back again in the same direction  $C F$ . But if a ray  $B C$  falls upon the surface obliquely, then the angle  $B C L$  will be called the *angle of incidence*; and when it has arrived at the surface  $L G$ , it will be reflected in the direction  $C E$ , making  $E C G$ , called the *angle of reflection*, equal to  $B C L$ . This is stated shortly by saying, that the angles of incidence and reflection are equal.

It is supposed that in the reflection of light, it does not actually come into contact with the surface of the body that reflects it, but that this effect is occasioned by some power that acts at a small distance from the surfaces of bodies. For, it is argued, that as the smoothest and best polished surfaces are so only in appearance, being in reality rugged and uneven, (polishing being nothing but the covering over with fine scratches, and breaking off the protuberances of bodies,) if light was reflected by actually striking on the solid

parts of bodies, it would be scattered as much by the most polished substances as by the roughest: and that, therefore, the reflection of a ray of light is effected not by a single point of the reflecting body, but by some power of the whole body evenly diffused all over its surface, and by which it acts on a ray without immediate contact.

No surface has the reflecting property so powerful as to reflect the whole of the light that falls upon it, a part being always absorbed; although there is a great difference in the quantity of the light reflected by different bodies. Metals reflect more light than any other substances. The reflection of the rays of light from the surfaces of bodies is the means by which they become visible; and the disposition of bodies to reflect particular coloured rays is the reason why they appear of that colour.

Every point in an object reflects rays in all directions; and, consequently, a certain number from each point enters the pupil, and is converged upon the retina, forming there the images of all the points of the object: hence it is that we see the whole of the surfaces of the bodies presented to us.

When the rays of light fall upon a rough surface, they are reflected very irregularly, and scattered in all directions; but when they fall upon polished surfaces, they are reflected with more regularity. Such a surface, when highly polished, is called a *mirror*, or *speculum*.

*Plane mirrors* are those whose surfaces are perfect planes, and whose section is a straight line; such are vulgarly called *looking-glasses*.

*Convex mirrors* are those whose middle parts are more prominent than their extremities or edges, and whose sections are curves, which may be either

circular, elliptical, parabolical, or hyperbolical. Thus  $C D$  (Plate 12. fig. 2.) is the section of a mirror whose surface is part of a globe, which is the sort mostly in use.

*Concave mirrors* are those whose surfaces sink in with a hollowness. The sections of these may be curves as various as the last.  $E F$  is a concave mirror, whose surface is part of the internal surface of a hollow sphere, which is the most common kind.

Plane mirrors have been made of various materials, and have been objects of great interest in all ages. The most ancient was probably the surface of smooth water; and this is still employed. Brass and silver have been used for this purpose by the Greeks and Romans. But all these have given place to the modern looking-glasses, which owe their property of reflecting so powerfully to a coating of an amalgam of quicksilver and tin foil, which is applied to the back of the glass.

Concave mirrors make objects appear larger, but distorted.

Convex mirrors, on the contrary, diminish the objects seen in them; a glass globe hung from the ceiling is an instance which every one has seen.

If rays continually recede from each other, they are said to *diverge*, as  $A d$ ,  $A c$ ,  $A f$ . (Plate 12. fig. 7.)

If they continually approach towards each other, they are said to *converge*, as  $c C$ ,  $d C$ . (Plate 12. fig. 5.)

The point at which converging rays meet, is called the *focus*, as  $C$ . (Plate 12. fig. 5.)

The rays of the sun proceed in straight lines which are parallel to each other; in this respect they differ from those of a candle, which diverge

like radii from a centre. If the sun's rays fall upon a plain mirror, they will continue parallel to each other after reflection. This may be familiarly illustrated by holding a piece of looking-glass in the sunshine, and throwing the reflection on a ceiling.

As it is by means of the rays that emanate from a body that it is rendered visible, so the eye refers the body itself to the place which is in the direction of the rays while entering the eye. But if the rays from the body have suffered any change in their direction, either by refraction or reflection, we shall then have an erroneous conception of the true situation of the body, for we shall refer it to the last direction of the ray.

In a plane mirror, the image of an object appears in the direction which the rays have, after being reflected from the glass. Thus, if an object be placed at A (Plate 26. fig. 3.), the rays from it which enter the eye C have been reflected in the direction B C; the eye at C, therefore, will refer the situation of the object to the direction C B; and it will appear to be behind the mirror at D, and just as far from it D E, as it is in reality before it E A. An eye placed at F will see itself as if at G, as far behind the glass as it is actually before it.

Objects appear larger or smaller to the eye, as the rays which proceed from their extremities to the eye make a greater or a smaller angle at the eye. Thus, the tree A B (Plate 26. fig. 4.) will appear larger than the tree C D, although they are actually of the same size, because the angle A E D is greater than C E D. This will be easily understood, because the rays crossing each other as they enter the pupil, the image of A B upon the retina

will be larger than that of  $C D$ . And hence it is that objects appear to diminish in proportion to their distance. The angle made at the eye, by rays from the utmost extremities of a body, is called the *visual angle*.

Parallel rays falling upon a convex mirror are rendered divergent; which will be obvious, by considering that each ray is reflected so as to make the angle of incidence and reflection equal. Let  $A B$  (Plate 26. fig. 5.) be a convex mirror, being part of a sphere whose centre is  $C$ ; then the line  $C D$ , being a radius of the sphere, is perpendicular to the surface of the mirror at  $C$ . Let  $F C$  and  $F B$  be two parallel rays falling upon the convex mirror: the ray  $E C$  will be reflected in the direction  $C G$ , making the angle  $D C G$  equal to  $E C D$ ; and the ray  $F B$  will be reflected in the direction  $B H$ , making the angle  $I B H$  equal to  $F B I$ . But  $G C$  and  $H B$ , if continued, would meet in  $K$ , and consequently form an angle, and have become divergent. In the same manner it may be shown, that divergent rays falling upon a mirror are rendered still more divergent, and convergent rays are rendered parallel, or less convergent.

When parallel rays, as  $d f a$ ,  $C m b$ ,  $e l c$ , (Plate 13. fig. 2.), fall upon a concave mirror,  $A B$ , they will be reflected back from that mirror, and meet in a point  $m$ , at half the distance of the surface of the mirror from  $C$ , the centre of its concavity. Thus, let  $C$  be the centre of concavity of the mirror  $A b B$ , and let the parallel rays  $d f a$ ,  $C m b$ , and  $e l c$ , fall upon it at the points  $a b$  and  $c$ . Draw the lines  $C i a$ ,  $C m b$ , and  $C h c$  from the centre  $C$  to these points: these lines will be perpendicular to the surface of the mirror, because

they proceed like so many radii from its centre. Make the angle  $C A h$  equal to the angle  $d a C$ , and draw the line  $a m h$ , which will be the direction of the ray  $d f a$ , after it is reflected from the point of the mirror: so that the angle of incidence  $d a C$  is equal to the angle of reflection  $C a h$ ; the rays making equal angles with the perpendicular  $C i a$  on its opposite sides.

Draw also the perpendicular  $C h c$  to the point  $c$ , where the ray  $e l c$  touches the mirror; and, having made the angle  $C c i$  equal to the angle  $C c e$ , draw the line  $c m i$ , which will be the course of the ray  $e l c$  after it is reflected from the mirror.

The ray  $C m b$  passes through the centre of concavity of the mirror, and falls upon it at  $b$ , the perpendicular to it; and is, therefore, reflected back from it in the same line  $b m C$ .

All these reflected rays meet in the point  $m$ ; and in that point the image of the body which emits the parallel rays  $d a$ ,  $C d$ , and  $e c$ , will be formed; which point is distant from the mirror equal to half the radius  $b m C$  of its concavity.

Upon this principle it is, that a concave mirror may be used to condense the sun's rays, and to excite an intense heat. If gunpowder, or any other inflammable substance be placed in the focus of such an instrument, it will be set on fire. Mirrors of polished metal have been used for this purpose. Plane mirrors, placed in the curve of a circle, have been employed to produce the same effect. With 40 glass mirrors so placed, Buffon burned deal boards at 66 feet distance, and with 117 he melted silver. It is supposed that this was the method by which Archimedes set on fire the Roman ships engaged in besieging Syracuse.



The rays which proceed from any remote terrestrial object are nearly parallel at the mirror; not strictly so, for they come diverging to it in separate pencils, or, as it were, bundles of rays, from each point of the side of the object next the mirror; therefore they will not be converged to a point at the distance of half the radius of the mirror's concavity from its reflecting surface, but in separate points at a little greater distance from the mirror. And the nearer the object is to the mirror, the farther these points will be from it; and an inverted image of the object will be formed in them, which will seem to hang pendant in the air, and will be seen by an eye placed beyond it (with regard to the mirror), in all respects like the object, and as distinct as the object itself.

Let  $A c B$  (Plate 13. fig. 3.), be the reflecting surface of a concave mirror, whose centre of concavity is at  $C$ ; and let the upright object  $D E$  be placed beyond the centre  $C$ , and send out a conical pencil of diverging rays from its upper extremity  $D$ , to every point of the concave surface of the mirror  $A c B$ : but to avoid confusion, we shall only draw three rays of that pencil, as  $D A$ ,  $D c$ ,  $D B$ .

From the centre of concavity  $C$ , draw the three right lines  $C A$ ,  $C c$ ,  $C B$ , touching the mirror in the same points where the aforesaid rays touch it, and all these lines will be perpendicular to the surface of the mirror. Make the angle  $C A d$  equal to the angle  $D A C$ , and draw the right line  $A d$  for the course of the reflected ray  $D A$ : make the angle  $C c d$  equal to the angle  $D c C$ , and draw the right line  $c d$  for the course of the reflected ray  $D c$ ; make also the angle  $C B d$  equal to the angle  $D B C$ , and draw the right

line  $Bd$  for the course of the reflected ray  $DB$ . All these reflected rays will meet in a point  $d$ , where they will form the extremity  $d$ , of the inverted image  $ed$ , similar to the extremity  $D$  of the upright object  $DE$ .

If the pencils of rays  $Ef$ ,  $Eg$ ,  $El$ , be also continued to the mirror, and their angles of reflection from it be made equal to their angles of incidence upon it, as in the former pencil from  $D$ , they will meet at the point  $e$  by reflection, and form the extremity  $e$  of the image  $ed$ , similar to the extremity  $E$  of the object  $DE$ .

As each intermediate point of the object between  $D$  and  $E$ , sends out a pencil of rays in like manner to every part of the mirror, the rays of each pencil will be reflected back from it, and meet in all the intermediate points between the extremities  $e$  and  $d$  of the image; and so the whole image will be formed not at  $i$ , half the distance of the mirror from its centre of concavity  $C$ ; but at a greater distance between  $i$  and the object  $DE$ ; and the image will be inverted with respect to the object.

This being well understood, the reader will easily see how the image is formed by the large concave mirror of the reflecting telescope, when he comes to the description of that instrument.

When the object is more remote from the mirror than its centre of concavity  $C$ , the image will be less than the object, and between the object and the mirror; when the object is nearer than the centre of concavity, the image will be more remote, and larger than the object; thus, if  $DE$  be the object,  $ed$  will be its image; for as the object recedes from the mirror, the image approaches nearer to it; and as the object approaches nearer to the mirror, the image recedes farther from it;

on account of the less or greater divergency of the pencils of rays which proceed from the object; for the less they diverge, the sooner they are converged to points by reflection; and the more they diverge, the farther they must be reflected before they meet.

If the object be in the centre of the mirror's concavity, the image and object will be coincident, and equal in bulk.

If a man place himself directly before a large concave mirror, but farther from it than its centre of concavity, he will see an inverted image of himself in the air, between him and the mirror, of a less size than himself. And if he hold out his hand towards the mirror, the hand of the image will come out towards his hand, and coincide with it, of an equal bulk, when his hand is in the centre of concavity; and he will imagine he may shake hands with his image. If he reach his hand farther, the hand of the image will pass by his hand, and come between it and his body; and if he move his hand towards either side, the hand of the image will move towards the other; so that whatever way the object moves, the image will move the contrary way.

All the while a bye-stander will see nothing of the image, because none of the reflected rays that form it enter his eyes.

Let a fire be made in a large room, and a smooth mahogany table be put at a good distance near the wall, before a large concave mirror, so placed that the light of the fire may be reflected from the mirror to its focus upon the table; if a person stand by the table, he will see nothing upon it but a long beam of light; but if he stand at a distance towards the fire, not directly between the

fire and mirror, he will see an image of the fire upon the table, large and erect. And if another person, who knows nothing of this matter beforehand, should chance to come into the room, and should look from the fire towards the table, he would be startled at the appearance; for the table would seem to be on fire. In this experiment there should be no light in the room, but what proceeds from the fire, and the mirror ought to be at least fifteen inches in diameter.

Take a glass bottle, fill it partly with water, and cork it in the common manner: place this bottle opposite a concave mirror, and beyond its focus, that it may appear reversed; then place yourself still farther distant than the bottle, and it will be seen in the air inverted, and the water which is actually in the lower part of the bottle, will appear to be in the upper.

If you invert the bottle whilst before the mirror, the image of the water will appear in the lower part of the bottle; when it is in this inverted state, uncork the bottle, and whilst the water is running out, the image is filling; but as soon as the bottle is empty, the illusion ceases. If the bottle likewise be quite full, there is no illusion. The remarkable circumstances in this experiment are: 1. Not only to see an object where it is not, but also where its image is not. 2. That of two objects, which are really in the same place, as the surface of the bottle, and the water it contains, the one is seen in one place, the other in another. It is supposed, that this illusion arises partly from our not being accustomed to see water suspended in a bottle with the neck downwards, and partly from the resemblance there is between the colour of air and the water.

The appearance of the image in the air, between the mirror and the object, has been productive of many agreeable deceptions, which, when exhibited with art, and an air of mystery, has been very successful, and a source of gain to many of our public show-men.

#### OF MICROSCOPES.

The word microscope signifies an instrument for viewing small objects.

It is usual to say, that the microscope magnifies objects seen through it : the reason of this will be seen by referring to what has been said respecting the optic angle.

The apparent magnitude of objects is measured by the angle which they are seen under by the eye ; and those angles are reciprocally as the distances from the eye. If, therefore, at the distance of six inches, we can but just discern an object, and then by interposing a lens, or other body, we can view that very object at a nearer distance, the object will appear to be as much larger through the lens than before to the naked eye, as its distance from the lens is less than its distance from the eye.

That this is the case, is evident from Plate 13. fig. 8, where *A* is a point in an object not clearly visible to the naked eye at a less distance than *A B*, because the rays which proceed from it are too divergent to admit of distinct vision till they have passed that distance ; but if the same object be placed in the focus *C* of the lens *D* (Fig. 9), the rays which proceed from it will become parallel, by passing through the lens, and, therefore, the

object is distinctly visible to the eye *E*, placed any where before the lens *D*. Consequently, it will appear as much larger through the lens than to the naked eye, as *CD* is less than *AB*.

If an object, *AB* (Fig. 10.), be placed in one focus *C*, of a lens *DE*, and the eye in the other focus *F*, the eye will see just so much of the object as is equal to the diameter of the lens; for the rays *AD* and *BE*, which go from the object to the extremities of the lens *D* and *E*, and are united at the focus *F*, must necessarily proceed from the object to the lens parallel to the axis *FC*, and, therefore, parallel to each other; consequently, the part of the object *AB*, seen by the rays *DF*, *EF*, will be equal to the diameter *DE* of the said lens.

If only the part *de* of the lens be open, then only so much of the object *ab*, as is equal to it, will be perceived by the eye. Now, since *AB* is equal to *DE*, or *ab* to *de*, therefore the angle *DFE*, or *dfe*, is the optic angle under which the part of the object *AB* or *ab* appears to the eye at *F*; and since *GF* is but one half *FC*, therefore the angle *DFE*, or *dfe*, is double that under which the part *AB* or *ab*, would appear to the naked eye at the distance *FC*; that is, the eye sees the object situated as above, twice as large with the lens as it would do without it.

If you would see a portion of an object larger than the lens, your eye must be placed nearer the lens than its focus. Let the lens be *DE* (Fig. 11), and its two foci *F* and *C*; in the focus *C*, let there be an object, *AB*, larger than the lens; suppose the rays *AD*, *BE*, proceed from the extremities of the object to those of the lens; it is evident from the figure, they will be convergent, and, therefore,

will by the lens be united in a point  $K$ , between the lens  $DE$  and its focus  $F$ : if then the eye be placed at  $K$ , it will take into its view an object greater than the lens  $DE$ .

Again, let  $GH$  be a portion of an object  $AB$ , less than the lens  $DE$ ; draw  $GD$ ,  $HE$ , which will be diverging rays, and, therefore, will be united at a point  $I$ , farther distant from the lens than the focus  $F$ ; hence, if an eye be placed farther from the lens than its focal distance, it can never see any object, or part of an object, at one view, so large as the lens, but always smaller. And, universally, the visible part of an object will be to the lens, as the focal distance of the lens to the distance of the eye.

Since, then, it is evident, the nature of a convex lens is such as will render an object distinctly visible to the eye at the distance of its focus, the reason why they are used as microscopes is very plain. For, suppose the distance,  $AB$  (Fig. 8. and 9.) be six inches, where the naked eye,  $B$ , can but just perceive the object  $A$  distinctly, and let the focal distance  $CD$  of the lens  $D$  be half an inch; then since  $CD$  is but one-twelfth of  $AB$ , the length of the object at  $C$  will appear twelve times as large as at  $A$ : if it were a surface, it would be 144 times as great; and the solidity, or bulk, would be magnified 1728 times.

If  $CD$ , the focal distance of the lens  $D$ , be but one-fourth part of an inch, then will that be but one twenty-fourth of  $AB$ , equal six inches, and the length of the objects will be magnified 24 times; the surface 576 times, and the solidity 13,824 times; for those numbers are the square and cube of 24. Whence it appears, that single glass lenses make very good microscopes, and have

these advantages, that the object appears most clear, they lie in little room, may be carried about any where, are to be had at a small price, and are most easy to be used.

A very convenient form of microscope is where A B (Plate 14. fig. 1.) is a circular piece of wood, ivory, &c. in the middle of which is a small hole, one-twentieth of an inch diameter : upon this hole is fixed, with a wire, a small lens C, whose focal distance is C D. At that distance is a pair of pliers, D E, which may be adjusted by means of the sliding screw, as in the figure, and opened by means of the two little studs *a e*; with these you take up any small object, O, and view it with the eye placed in the other focus of the lens at F; and according to the focal length of the lens, the object O will appear more or less magnified, as represented at I M. If the focal length be half or one-fourth of an inch, the length, surface, and bulk of the object will be magnified as before described. This small instrument may be put into a case for the pocket. Those lenses, whose focal lengths are three-tenths, four-tenths, and five-tenths of an inch, are the best for common use.

Since the nearer the eye can approach to an object, the larger it appears, it is plain, a double and equally convex lens magnifies more than a plano-convex lens; because, if the sphere, or convexity, be the same, the focal length of the former is but half as long as of the latter; and since the double convex consists of two segments of a sphere, the more an object is to be magnified, the greater must the convexity be, and therefore the smaller the sphere; till at last the utmost degree of magnifying will require that these segments become hemispheres, and, consequently, the lens will be



reduced to a perfect spherule, or very small sphere.

If the radius of the spherule be one-tenth of an inch, the eye will have distinct vision of an object by means thereof, at the distance of  $1\frac{1}{2}$  radius; *i. e.* three-twentieths of an inch, which, as it is but the fortieth part of six inches, shows that the length of an object will be magnified forty times, the surface 1600 times, and the solidity 64,000 times, by such a small sphere.

If the radius of a spherule be but one-twentieth of an inch, then will the eye have distinct vision of an object at the distance of three-fortieths of an inch, which, as it is but the eightieth part of six inches, shows the length of objects will appear 80 times greater, the surface 6400 times, and the bulk 512,000 times greater to the naked eye at six inches distance.

In using these spherule microscopes, the objects are to be placed in one focus, and the eye in the other; and since the focus is so exceeding near the glass, it is impossible to view any but pellucid bodies; for if any opaque object were to be applied, the eye being, as it were, just on the spherule, would entirely prevent any light falling on it, and it would be too obscure to be viewed.

It was with this sort of microscopes that the famous Dutch philosopher, Leuwenhoek, made wonderful discoveries. But the great difficulty of making very small and at the same time very good ones; their prejudice to the eyes, in poring very hard and near; the trouble of placing objects at a due distance, and the very small part which can be seen of any, make this sort of microscopes very little known or used.

The following is a *single microscope for opaque objects*, which remedies the inconvenience of having the dark side of an object next the eye, which has hitherto been a great obstruction in making observations on opaque objects.

The several parts of this instrument, commonly made of brass, are as follow :

Through the first side A passes a fine screw B, the other end whereof is fastened to the moveable side C (Fig. 2.)

D is a nut adapted to the said screw, by the turning of which the two sides A, C, are gradually brought together.

E is a spring of steel, that separates the said two sides when the nut is unscrewed.

F, a piece of brass turning round in a socket, whence proceeds a small spring tube, moving upon a rivet; through this tube there runs a steel wire, one end whereof terminates in a sharp point G, and the other has a pair of pliers, H, fastened to it. The point and pliers are to thrust into, or to take up and hold any insect or object: and either of them may be turned upwards, as suits the purpose best.

I is a ring of brass with a female screw within it, mounted on an upright piece of the same metal, which turns round on a rivet, that it may be set at a due distance when the least magnifiers are employed. This ring receives the screws of all the magnifiers.

P, a handle turned of wood, to screw into the instrument when it is used.

K, a concave speculum of silver, polished as bright as possible, in the centre of which a double convex lens is placed, with a proper aperture to

look through it. On the back of this speculum a male screw L is made to fit the brass ring I, to screw into the said ring at pleasure.

There are four of these concave specula, of different magnifying powers, to be used as objects to be examined may require. The greatest magnifiers must always have the least apertures.

M (Fig. 3.), a round object-plate, one side white, and the other black, intended to render objects the more visible, by placing them, if black, on the white, and if white, on the black side. A steel spring, N, turns down on each side, to make any object fast; and issuing from the object-plate, is a hollow pipe to screw it on the needle's point G.

O (Fig. 4.), is a small box of brass, with a glass on each side, contrived to confine any living object, in order to examine it: this, also, has a pipe to screw upon the end of the needle G.

A soft hair-brush is necessary to clean the glasses, or specula; and a drop of any liquid may be applied to the isinglass of the box O, in order to view animalcules.

When you would view any object, screw the speculum with the magnifier you would think best to use, into the brass ring I. Place the object either on the needle G, in the pliers, H, on the object-plate M, or in the brass hollow box, O, as may be most convenient, according to the nature and condition of it: then holding up the instrument by the handle P, look against the light through the magnifying lens; and by means of the nut D, together with the motion of the needle, by managing its lower end, the object may be turned about, raised, or depressed, brought nearer the glass, or put farther from it, till you hit the

true focal distance, and the light be seen reflected from the speculum strongly upon the object; by which means it will be shown in a manner surprisingly distinct and clear. And, for this purpose, the light of the sky, or of a candle, will answer.

Though this microscope is principally intended for opaque objects, which are very difficult to examine, yet transparent ones may also be viewed by it: observing only, that when such come under examination, it will not always be proper to throw on them the light reflected from the speculum: for the light transmitted through them meeting the reflected light, may, together, produce too great a glare. A little practice will teach how to regulate both these lights to good advantage.

In *Wilson's single pocket microscope*, the body is made either of brass, ivory, or silver.

C (Fig. 5.), is a long fine-threaded male screw, that turns into the body of the microscope B.

D, a convex glass at the end of the said screw.

There are two concave round pieces of thin brass, with holes of different diameters in the middle of them, to cover the said glass, and thereby diminish the aperture when the greatest magnifiers are employed.

E E, three thin plates of brass within the body of the microscope, one whereof is bent semicircularly in the middle, so as to form an arched cavity for the reception of a tube of glass, whereas the two flat plates are to receive and hold the sliders between them.

At G, the other end of the body of the microscope, a hollow female screw is adapted to receive the different magnifiers.

H, a spiral spring of steel, between the end G, and the plates of brass; intended to keep the plates in a right position, and act against the long screw C.

I, a small turned handle, for the better hold of the instrument, to screw on or off at pleasure.

To this microscope belong seven different magnifying glasses; six of them are set in silver, brass, or ivory, and marked 1, 2, 3, 4, 5, 6, the lowest numbers being the greatest magnifiers.

L (Fig. 6.) is the seventh magnifier, set in the manner of a little barrel, to be held in the hand for the viewing any larger object.

This may be of further use: by applying a thin cap, with a hole in it, a quarter of an inch square, exactly in the focus of the lens, when a piece of linen cloth is applied upon the brass, and viewed through the other end, the threads will appear greatly magnified, so that they may be counted, and thereby the quality of the cloth may be ascertained by calculation.

M (Fig. 7.), is a flat slip of ivory, called a slider, with four round holes through it, in which are placed objects between two glasses, or pieces of mica.

Eight such ivory sliders, and one of brass, are usually sold with this microscope; some with objects placed in them, and others empty, for viewing any thing that may offer, but whoever wishes to make a large collection of objects, may have as many as he desires.

The brass slider is to confine any small object, that it may be viewed without crushing or destroying it.

Fig. 8. is a forceps, or pair of pliers, for taking up insects, or other objects, and adjusting them to the glasses.

Fig. 9. is a tube of glass, contrived to confine living objects, such as frogs, fishes, &c. in order to discover the blood as it flows along the veins and arteries.

All these particulars are contained in a little neat box, very convenient for carrying in the pocket.

When an object is to be viewed, thrust the ivory slider, in which the object is placed, between the two flat brass plates, E E; observing always to put that side of the slider where the brass rings are, farthest from the eye. Then screw on the magnifying glass you intend to use, at the end of the instrument G: and looking through it against the light, turn the long screw C, until the object be brought to fit your eye; which you will know by its appearing then perfectly distinct and clear. It is best to look at it first through a magnifier that can show the whole of it at once, and afterwards to inspect the several parts more particularly with one of the greatest magnifiers; for thus you will gain a true idea of the whole, and of all its parts. And, though the greatest magnifiers can show but a minute portion of any object at once, yet, by gently moving the slider that contains the object, the eye will gradually examine it all; and if any part should be out of distance, the screw C will easily bring it to the true focus.

As the object must be brought very near the glasses when the greatest magnifiers are used, be particularly careful not to scratch them as you move it in or out. A few turns of the screw C will easily prevent this mischief, by giving room enough.

You may change the objects' in your sliders for what others you think proper, by taking out the

brass ring with the point of a penknife: the mica will then fall out, if you but turn the sliders; and after putting what you please between them, by replacing the brass rings, you will fasten them as they were before. It is proper to have some sliders furnished, but without any objects, to be always in readiness for the examination of fluids, salts, sands, powders, the farina of flowers, or any other objects of such sort as need only be applied to the outside of the mica.

The circulation of the blood may easiest be seen in the tails and fins of fishes, in the fine membranes between a frog's toes, or, best of all, in the tail of a water-newt. If your object be a small fish, place it within the tube, and spread its tail, or fin, against the side thereof; if a frog, choose such a one as can but just be got into your tube, and with a pen, or stick, expand the transparent membrane between the toes of the hind foot as wide as you are able. When your object is so adjusted, that no part thereof can intercept the light from the place you intend to view, unscrew the long screw C, and thrust the tube into the arched cavity, quite through the body of the microscope; then screw it to the true focal distance, and you will see the blood passing along its vessels with a rapid motion.

Make use of the third or fourth magnifier for frogs or fishes; but for the tails of water-newts, the fifth or sixth will do, because the globules of their blood are twice as large as those of frogs or fish. The first or second magnifier cannot well be employed to this purpose; for the thickness of the tube wherein the object lies will scarce admit its being brought so near as the focal distance of the magnifier.

*Ellis's single, or aquatic microscope*, takes its name from Mr. John Ellis, author of *An Essay towards a Natural History of Corallines*. By this instrument he was enabled to explain many singularities in the economy and construction of these wonderful productions of nature.

To the practical botanist this instrument is recommended by the authority of Mr. Curtis, author of the *Flora Londinensis*. It is simple in its construction, easy in its use, and very portable.

K (Fig. 10.) is the box which contains the whole apparatus: on the top of the box there is a female screw, for receiving the screw which is at the bottom of the brass pillar A, and which is to be screwed on the top of the box K. D, a brass pin, which fits into the pillar: on the top of the pin is a hollow socket, to receive the arm which carries the magnifiers: the pin is to be moved up and down, in order to adjust the lenses to their focal or proper distances from the object.

In the representation of this microscope, the pin D is delineated as passing through a socket at one side of the pillar, A: it is now usual to make it pass down a hole bored down the middle of the pillar. F is the box which carries the magnifying lens: it fits into the socket X, which is at the top of the pillar D. This arm may be moved backward and forward in the socket X, and sideways by the pin D, so that the magnifier, which is screwed into the ring at the end F of this box, may be easily made to traverse over any part of the object lying on the stage or plate B. F is a polished silver speculum, with a magnifying lens placed at the centre of it, which is perforated for this purpose. II, is a brass semicircle which supports the mirror I; the pin R, affixed to the semi-



circle H, passes through the hole which is towards the bottom of the pillar A. B, the stage on which the objects are to be placed; it fits into a small dove-tailed arm which is at the upper end of the pillar, A. C, a plane glass with a small piece of black silk stuck on it. This glass is fitted to a groove made in the stage B; a pair of nippers is fixed to the hole of the stage *a*, by the pin K; the steel wire of these nippers, slides backwards and forwards in the socket; and this socket is moveable upwards and downwards, by means of the joint, so that the position of the object may be varied at pleasure. The object may be fixed in the nippers, or stuck on the point.

To use this microscope, begin by screwing the pillar A to the cover; pass the pin R, of the semi-circle which carries the mirror through the hole, that is near the bottom of the pillar A; push up the stage into the dove-tail at B; slide the pin into the pillar; then pass the bar E, through the socket X, which is at the top of the pin D, and screw one of the magnifying lenses into the ring at F. Now place the object either on the stage, or in the nippers, L, and, in such a manner, that it may be as nearly as possible over the centre of the stage; bring the speculum F over the part you mean to observe; then get as much light on the speculum as you can, by means of the mirror, I. The light received on the speculum is reflected by it on the object. The distance of the lens F from the object is regulated by moving the pin D up and down, until a distinct view of it be obtained. The rule usually observed is, to place the lens beyond its focal distance from the object, and then gradually slide it down, until the object appear sharp and well defined. The adjustment of the lenses

to their foci, and the distribution of the light on the object, are what require the most attention. These microscopes are sometimes fitted up with a rack and pinion, to the pillar A and pin D, for the more ready adjustment of the glasses to their proper foci.

The following is a single microscope on a foot or stand. A B (Fig. 11.) is the basis or foot, C I is the stem; E F, are two square sockets of brass, moveable up and down together upon the square part of the stem, being connected by a common screw; but this motion is checked by the constant pressure of a spring. G is a screw, by which the part E is fixed to the stem.

H is an adjusting screw, by which the part F is gradually moved up and down; and thereby K L, the stage on which the objects are placed, has M N, the slider, with its objects, duly adjusted to the focus of the magnifiers.

O is the circular piece of brass, on which are fixed three lenses turning on centres fixed in O, and which may be used either separately, or combined together; R is the speculum, that reflects the light through the microscope.

A *megalascope* is an optical instrument, adapted for viewing all the larger sort of small objects; such as insects, flowers, minerals, linen, &c. to a very great advantage; as, with three glasses only, it has seven different magnifying powers.

A (Fig. 12.) is the case of brass, silver, &c.; D, E, F, three several lenses with different magnifying powers; which are all contained in the case, and turned out at pleasure: H the handle.

The three glasses, singly, afford three magnifying powers; and, by combining two and two, we make three more: for D with E makes one, D

with F another, and E with F a third, which, with the three singly, make six; and, lastly, all three combined together, make another, so that, upon the whole, there are seven powers of magnifying with three glasses only.

The *double, or compound microscope*, consists of an object-glass  $cd$  (Plate 15. fig. 1.), and an eye-glass  $ef$ . The small object  $ab$ , is placed at a little greater distance from the glass  $cd$ , than its principal focus, so that the pencils of rays flowing from the different points of the object, and passing through the glass, may be made to converge and unite in as many points between  $g$  and  $h$ , where the image of the object will be formed; which image is viewed by the eye through the eye-glass  $ef$ ; for the eye-glass being so placed, that the image  $gh$ , may be in its focus, and the eye much about the same distance on the other side, the rays of each pencil will be parallel after going out of the eye-glass, as at  $e$  and  $f$ , till they come to the eye at  $h$ , where they will begin to converge by the refractive powers of the humours; and, after having crossed each other in the pupil, and passed through the crystalline and vitreous humours, they will be collected into points on the retina, and form the large inverted image  $AB$  thereon.

The magnifying power of this microscope is as follows: suppose the image  $gh$  to be six times the distance of the object  $ab$  from the object-glass  $cd$ ; then will the image be six times the length of the object; but since the image could not be seen distinctly by the bare eye at a less distance than six inches, if it be viewed by an eye-glass  $ef$ , of one inch focus, it will thereby be brought six times nearer the eye, and consequently viewed under an angle six times as large as before; so that it will be

again magnified six times; that is, six times by the object-glass, and six times by the eye-glass; which, multiplied into one another, makes thirty-six times; and so much is the object magnified in diameter more than what it appears to the bare eye, and consequently thirty-six times thirty-six, or 1296 times in surface.

But because the extent or field of view is very small in this microscope, there are generally two eye-glasses placed sometimes close together, and sometimes an inch asunder; by which means, although the object appear less magnified, yet the visible area is much enlarged by the interposition of a second eye-glass, and consequently a much pleasanter view is obtained.

A Q is the body or internal part, which is moveable up and down in C D (Fig. 2.) an external case of wood, brass, or silver. E, one of the three pillars which support the instrument. F, a plate fixed (horizontally) to the legs, usually called the stage: there is a hole in the central part, in which glass, and other parts of the apparatus, are placed, with objects to be viewed. H, an illuminating or reflecting speculum. I, the foot of the instrument. Q, a brass button, or case, to hold the magnifier.

In this compound microscope, there are generally three (sometimes four) glasses employed to produce the effect, viz. 1. The magnifying lens at Q, which makes a large image in the upper part of the small object below. 2. A large lens at B, called the body-glass, which is the cause of a larger field of view. 3. An eye-glass at A, by which we view the enlarged image of the object in its focus.

The *magnifying power* in all optical instruments depends upon this one principle, that every object is apparently greater or less, in proportion as it is

nearer to, or farther from, the eye; because the nearer it is, the larger is the visual angle under which it appears, and vice versa.

But the eye is so formed as to admit of distinct vision by such rays only as are nearly parallel; and therefore every object must be removed to such a distance from the eye, that the rays of light issuing from every point thereof, may fall upon the eye with small divergency, or nearly parallel; which distance is, in different eyes, from six to eight inches, as any one may find by trial.

Now, since a convex glass converges parallel rays to a point or focus; therefore, on the contrary, if an object be placed in the focus of such a lens, the rays proceeding from each point will be refracted parallel to the eye, and thereby produce distinct vision of that object in its focus.

Hence, then, it follows, that if  $a b$  be a very small object in the focus of the glass C (Fig. 3.) whose focal distance is one inch, the eye applied to the lens C will have the distinct vision of it; and this being at a distance six, seven, or eight times nearer than the eye alone could clearly see it, it must appear so many times larger than to the naked eye; and therefore, we properly say, it is magnified to such eyes, six, seven, or eight times in length and breadth.

But all surfaces are magnified in proportion to the squares of their lengths or sides; therefore the surfaces of objects are magnified thirty-six, forty-nine, or sixty-four times, by a lens of one inch focal distance.

Also the bulk or magnitude of the whole body, will be magnified in proportion to the cubes of the sides or length; and therefore all solid bodies will, by such a lens, be magnified 216, 343, or 512 times to such eyes respectively.

If the lens C were but of half an inch focal distance, the lengths of the objects would be magnified twice as much; the surfaces four times, and the magnitude or bulk, eight times as much as before.

If the focal distance of the lens C be a quarter of an inch, then the lengths are magnified four times as much, viz. twenty-four, twenty-eight, or thirty-two times; the surfaces sixteen times as much, or 576 times more than to the naked eye at six inches distance; and solid bodies are magnified sixty-four times more than by the lens of a whole inch focal distance.

Again; suppose the lens so small that its focal distance is but one-tenth of an inch, then the length of an object is magnified sixty, seventy, or eighty times; the surface 3600, 3900, or 6400 times; and the solidity, or whole bulk, 216,000, 343,000, or 512,000 times, or so much larger do the bodies of mites, or their eggs, appear than to the naked eye at six, seven, or eight inches distance.

After the same manner you may compute the magnifying power of lenses of one-twentieth, one-thirtieth, one-fortieth, and even one-fiftieth part of an inch focal distance, which may be made, if required; but they are with difficulty used. By a lens one-fiftieth of an inch, the length is magnified 300 times, and the surface 90,000 times, and the solidity 27,000,000 times.

But these enormous powers of magnifying are much better effected in compound microscopes; and be that in what degree you please, it is thus easily estimated. Let C be the object-lens in the cell Q (Fig. 2.) of the compound microscope; if, then, a small object,  $a b$ , be placed on the stage at a little more than the focal distance, there will be

formed by the said lens C, a large image S T, in the upper part of the microscope; and this image is viewed through the glass G H in its focus below at O.

Now it is easy to understand, that the image S T is as much larger than the object *a b*, as the distance C A exceeds the distance C *a* from the lens. Suppose the image S T six times larger than the object *a b*; then if it be viewed by a lens G H of one inch focal distance, the image S T will appear magnified six times at least, and therefore the object *a b* will be magnified six times six, or 36 times in length; and 36 times 36, or 1296 times in surface; and 36 times 1296, or 46,656 times in the bulk of solidity. And yet with these great powers of magnifying, the lens C may not be of less than half an inch focal distance, in the least sort of compound pocket microscopes.

But with a single eye-glass G H, we have too small a field of view; therefore we use two, viz. A B and D E; the first contracts the image S T into another, I M, which is less; and this is viewed by the eye-glass D E. Now both these glasses may have a magnifying power equal to that of a given single glass G H, by this rule: Let their distance be equal to the difference of their focal lengths, and their magnifying power will be equal to that of a lens, whose focal distance is half that of the greater A B.

For example—Suppose the focal length of A B to be  $2\frac{1}{2}$  inches, and that of D E 1 inch; then if their distance be  $1\frac{1}{2}$  inch, their joint magnifying power will be equal to that of a single lens G H, whose focal distance is  $1\frac{1}{4}$  equal half that of A B. By the two eye-glasses the rays are converged to the eye at the compound focus F, much less

affected by the errors arising from the aberration of rays, both from their different refrangibility and the figure of the glasses.

*The solar, or camera obscura microscope*, requires the sunshine, and must be made use of in a darkened chamber, as its name implies.

It is composed of a tube, a looking-glass, a convex lens, and Wilson's single pocket microscope, before described, or any other similar one.

The sun's rays being directed by the looking-glass through the tube upon the object, the image or picture of the object is thrown, distinctly and beautifully, upon a screen of white paper, or a white linen sheet, placed at some distance to receive the same; and may be magnified to an immense size; for the farther off the screen is removed, the larger will the object appear; insomuch, that a mite may be magnified to the length of five or six feet, or even a great deal more; but it is indeed more distinct when not enlarged to above half that size.

The apparatus for this purpose, as represented in the plate annexed, is as follows: A (Fig. 4.), a square wooden frame, through which two long screws pass, and assisted by a couple of nuts, 1 1, fasten it firmly to a window-shutter, wherein a hole is made for its reception: the two nuts being let into the shutter, and made fast thereto.

A circular hole is made in the middle of this frame, to receive a piece of wood of a circular figure B, whose edge, that projects a little beyond the frame, composes a shallow groove, wherein runs a catgut; which by twisting round, and then crossing over a brass pulley 4, (the handle whereof, 5, passes through the frame,) affords an easy



motion for turning round the circular piece of wood B, with all the parts affixed.

C is a brass tube covered with seal skin, which, screwing into the middle of the circular piece of wood, becomes a case for the uncovered brass tube D, to be drawn backwards or forwards in. E, a smaller tube of about one inch in length screwed to the end of the larger tube D. To the end of this the microscope must be screwed.

f is a convex lens, whose focus is about twelve inches, designed to collect the sun's rays, and throw them more strongly upon the object. G, a looking-glass of an oblong figure, set in a wooden frame, fastened by hinges to the circular piece of wood B, and turning about with it, by means of the above-mentioned catgut.

H, a jointed wire passing through the wooden frame, to enable the observer (by putting it backwards or forwards) to elevate or decline the glass, according to the sun's altitude.

The extremities of the catgut are fastened to a brass pin; by turning which it may be braced up, if at any time it becomes too slack. This pin, lying behind, could not be shown in the plate.

When this microscope is employed, the room must be rendered as dark as possible; for on the darkness of the room, and the brightness of the sunshine, depend the sharpness and perfection of the image. Then putting the looking-glass G through the hole in the window-shutter, fasten the square frame A to the said shutter by its two screws and nuts, 1 1.

This done, adjust the looking-glass to the elevation and situation of the sun, by means of the jointed wire H, together with the catgut pulley; for the first of these raising or lowering the glass,

and the other reclining it to either side, there results a twofold motion, which may easily be so managed as to bring the glass to a right position; that is, to make it reflect the sun's rays directly through the lens, upon the paper screen, and form thereon a spot of light exactly round.

Though the obtaining a perfect circular spot of light upon the screen before you apply the microscope, is a certain proof that the looking-glass is adjusted right, yet that proof must not always be expected; for the sun is so low in winter, that if it shine in a direct line against the window, it cannot then afford a spot of light exactly round. But if it be on either side of you, a round spot may be obtained, even in December.

As soon as this appears, screw the tube C into the brass collar provided for it in the middle of the wood-work, taking care not to alter the looking-glass; then screwing the magnifier you choose to employ to the end of the microscope, in the usual manner, take away the lens at the other end of it, and place a slider, containing the object to be examined, between the thin brass plates, as in the other ways of using the microscope.

Things being thus prepared, screw the body of the microscope to the short brass tube E, and pull out the tube D, less or more, as the object is capable of enduring the sun's heat. Dead objects may be brought within about an inch of the focus of the convex lens 5; but the distance must be shortened for living creatures, or they will soon be killed.

If the light falls not exactly right, you may easily, by a gentle motion of the jointed wire and pulley, direct it through the axis of the microscopic lens.

The short tube E, which the microscope is screwed to, enables you, by sliding it backwards or forwards in the other tube D, to bring the objects to their true focal distance; which will be known by the sharpness and clearness of their appearance; they may also be turned round by the same means, without being in the least disordered.

The magnifiers most useful in the solar microscope are, in general, the fourth, fifth, or sixth.

This microscope is the most entertaining of any. There are also several conveniences attending it, which no other microscope can have; for the weakest eyes may use it without the least straining or fatigue: numbers of people may view any object together at the same time. Such, too, as have a little skill in drawing, may, by this contrivance, easily sketch out the exact form of any object they have a mind to preserve a figure of; since they need only fasten a paper upon the screen, and trace it on it, either with a pen or pencil.

For this purpose a frame might be made, in which a sheet of paper may be put in or taken out at pleasure; for if the paper be single, the image of an object will be seen as plainly almost on the back as on the other side; and by standing behind the screen, the shade of the hand will not obstruct the light in drawing, as it must in some degree when one stands before it.

It must be observed, that formerly the solar microscope had no looking-glass belonging to it, and, therefore, was of use a few hours only in a day, when the tube could be placed directly against the body of the sun, and even then not without a good deal of trouble: but by this lucky contrivance of a looking-glass, the sun's rays may be reflected through the tube, whatever its height or

situation be, provided it shine at all upon the window.

The following is a diagram of the solar microscope: Let  $A B$  (Fig. 5.) be a section of the window-shutter of a dark room, containing a scioptic ball  $E F$ ; in the fore-part of which is screwed the tube  $G I K H$ , at one end of the tube is a lens  $G H$ , which, by converging the sun-beams into a narrow compass, strongly enlightens the small object  $a$ , placed on a slip of glass, or otherwise, in the part of the tube  $G H$ , where a slit is made on each side for that purpose. Within this tube there slides another,  $L m$ , which contains a small magnifying lens,  $m r$ .

By moving the exterior tube  $I G H K$  one way and the other, the glass  $G H$  will be brought to receive the rays of the sun directly, and will therefore most intensely illuminate the object  $a$ . The other tube  $L M$ , being slid backwards and forwards, will adjust the distance of the small lens, so that the image of the object  $a$  shall be made very distinct on the opposite side of the room at  $O P$ ; and the magnitude of the image will be to that of the object, as the distance from the lens  $m r$  is to the distance of the object from it; as is evident from the figure.

A *micrometer* is an instrument for measuring extremely small objects. It is of various constructions. The following one is extremely simple. It is nothing more than a stage on which the objects are placed, moveable by a fine screw, which has a hand, or small index, passing over the divisions of a graduated circle. A fine threaded screw is the essential part in all micrometers of the best or most perfect kind. This screw was formerly placed in the focus of the eye-glass, just where the image is formed: but this method of applying it was

found to give some trouble in understanding and computing the dimensions taken by it; and, therefore, it is here applied to the stage, or rather to the object itself; which renders the use of it more pleasant.

The upper part of the microscope, which contains the glass, has a fine wire in its focus, and to it any part of the image may be applied; or the wire may be applied to any part of the image, by a proper construction of the upper part of the microscope for that purpose. The object being then placed in a proper manner on the stage, the screw is to be turned till the image of the object has passed its whole length or breadth under the wire, and then its dimensions will be known. Thus, for example:

The number of threads on the screw in one inch is fifty, and the number of divisions on the circular plate is twenty. Therefore one thread, or one turn of the screw, measures one-fiftieth part of an inch: and one division of the plate is one-twentieth of one-fiftieth, that is, one-thousandth part of an inch. So that such a micrometer will very exactly measure any small object, or its smaller parts to the thousandth part of an inch.

Suppose the subject were a mite, and it were required to measure the length of it; place it in a slider, and that slider on a stage, in such a manner that the mite may move lengthwise in the direction of a screw; then move or set the wire at right angles to it, and so as touch the image of the mite at one end, very exactly. This done, turn the wire till the image has passed its whole length under the wire; and having counted the turns, you will find them four, and fourteen divisions of another; the four turns are  $\frac{4}{50}$  or  $\frac{8}{100}$ , and the fourteen divisions are  $\frac{14}{1000}$ ; so that the whole length

of the mite is  $\frac{1}{1000}$  part of an inch, which is almost one-tenth part of an inch.

Again, suppose you measure the length of the egg of a mite, and find one turn of the screw, and three divisions on the plate, carry it completely under the wire; then one revolution of the screw is  $\frac{1}{25}$  or  $\frac{2}{500}$ , and three divisions are  $\frac{3}{1000}$ ; so the whole length of the egg is equal to  $\frac{1}{166\frac{2}{3}}$  of an inch, that is, almost one forty-fourth part of an inch; or forty-four such eggs of a mite will, if laid contiguously in a right line, be nearly equal to one inch in length.

The micrometer may be easily applied to the solar microscope; for let a fine straight line be drawn on the screen, and the end or side of the image be placed to touch it; then by turning the screw, it will thereby be measured in thousandth parts of an inch.

By the micrometer the naturalist acquires an idea of the wonderful disproportion there is between the magnitudes or dimensions of the smallest and of the largest objects of the animal tribe; as between the smallest of the finny fry and the largest whale; an animalcule in vinegar, and a snake thirty or forty feet long. And that the reader may have a perception of such a surprizing contrast in the works of Nature, we shall here give him a calculation of the comparative magnitude of the egg of a mite, and that of an ostrich.

Suppose the length of an ostrich's egg to be five inches, let the length of the egg of a mite be one-fiftieth of an inch, then the lengths of these two eggs will be to each other as five to one-fiftieth, or two hundred and fifty to one; then, as they are similar bodies, their magnitudes will be as the cubes of these numbers, viz. as 15,625,000 to one;

that is, in words, one egg of an ostrich is equal to fifteen million six hundred and twenty-five thousand eggs of a mite. And there is great reason to believe, that there are eggs of other animalculæ far less than those of a mite. Indeed, the greatest stretch of the human mind is insufficient to explore the amazing and inconceivable gradations in every part of Nature; and nothing but the all-piercing eye of boundless Intelligence can see through a series of such infinitely decreasing progressions.

It may be here worth noticing, that a telescope is easily converted into a microscope, by removing the object-glass to a greater distance from the eye-glasses; for the distance of the image varies with the distance of the object from the focus, and is more magnified, as its distance from the object is greater: the same telescope may, therefore, be successively turned into a microscope with different powers. Botanists might find some advantage in attending to this; it would assist them in discovering small plants at a distance, and thus often save them from the thorns of a hedge, and the dirt of a ditch.

### *Telescopes.*

In a *refracting telescope*, the glass which is nearest the object in viewing it is called the *object-glass*; and that which is nearest the eye is called the *eye-glass*. The object-glass must be convex, but the eye-glass may be either convex or concave; and generally, in looking through a telescope, the eye is in the focus of the eye-glass, though that is not very material; for the distance of the eye, as to distinct vision, is indifferent, provided the rays

of the pencils fall upon it parallel; only, the nearer the eye is to the end of the telescope, the larger the scope or area of the field of view.

Let  $c d$  (Plate 16. fig. 3.) be a convex glass fixed in a long tube, and have its focus at  $E$ . Then a pencil of rays  $g h i$ , flowing from the upper extremity  $A$  of the remote object  $A B$ , will be so refracted by passing through the glass, as to converge and meet in point  $f$ ; whilst the pencil of rays  $k l m$ , flowing from the lower extremity  $B$ , of the same object  $A B$ , and passing through the glass, will converge and meet in the point  $e$ : and the images of the point  $A$  and  $B$ , will be formed in the points  $f$  and  $e$ . And as all the intermediate points of the object between  $A$  and  $B$  send out pencils of rays in the same manner, a sufficient number of these pencils will pass through the object-glass  $c d$ , and converge to as many intermediate points between  $e$  and  $f$ ; and so will form the whole inverted image  $e E f$ , of the distinct object. But because this image is small, a concave glass,  $n o$ , is so placed in the end of the tube next the eye, that its virtual focus may be at  $F$ . And as the rays of the pencils pass converging through the concave glass, but converge less after passing through it than before they go on further, as to  $b$  and  $a$ , before they meet, and the pencils themselves being made to diverge by passing through the concave glass, they enter the eye, and form the large picture  $a b$ , upon the retina, whereon it is magnified under the angle  $b F a$ .

But this telescope has one inconvenience which renders it unfit for most purposes; which is, that the pencils of rays being made to diverge by passing through the concave glass  $n o$ , very few of them can enter the pupil of the eye; and, therefore,



the field of view is but very small, as is evident by the figure. For none of the pencils, which flow either from the top or bottom of the object  $A B$ , can enter the pupil of the eye at  $C$ , but are stopped by falling upon the iris above and below the pupil; and, therefore, only the middle part of the object can be seen when the telescope lies directly towards it, by means of those rays which proceed from the middle of the object. So that to see the whole of it, the telescope must be moved upwards and downwards, unless the object be very remote; and then it is never seen distinctly.

This inconvenience is remedied by substituting a convex eye-glass, as  $g h$  (Fig. 2.), in place of the concave one; and fixing it so in the tube, that its focus may be coincident with the focus of the object-glass  $c d$ ; as at  $E$ . For then the rays of the pencils flowing from the object  $A B$ , and passing through the object-glass  $c d$ , will meet in its focus, and form the inverted image  $m E p$ ; and as the image is formed in the focus of the eye-glass  $g h$ , the rays of each pencil will be parallel, after passing through that glass; but the pencils themselves will cross in its focus, on the other side, as at  $e'$ ; and the pupil of the eye being in this focus, the image will be viewed through the glass, under the angle  $g e h$ ; and being at  $E$ , it will appear magnified, so as to fill the whole space  $C m e p D$ .

But, as this telescope inverts the image with respect to the object, and is only fit for viewing the heavenly bodies, in which we regard not their position, because, on account of their being round, they do not appear inverted.

The magnifying power of this telescope is, as the focal distance of the object-glass to the focal distance of the eye-glass. Therefore, if the former

be divided by the latter, the quotient will express the magnifying power.

This telescope may be made to magnify in any given degree, provided it be of a sufficient length. For the greater the focal distance of the object-glass, the less may be the focal distance of the eye-glass, though not directly in proportion. Thus, an object-glass of ten feet focal distance will admit of an eye-glass whose focal distance is little more than two inches and a half; which will magnify near forty-eight times; but an object-glass of one hundred feet focus will require an eye-glass somewhat more than six inches; and will, therefore, magnify almost two hundred times.

A telescope for viewing terrestrial objects should be constructed so as to show them in their natural posture. And this is done by one object-glass  $c d$  (Fig. 3.), and three eye-glasses  $e f$ ,  $g h$ ,  $i k$ , so placed, that the distance between any two, which are nearest to each other, may be equal to the sum of their focal distances, as in the figure, where the focus of the glasses  $c d$  and  $e f$  meet at  $F$ , those of the glasses  $e f$  and  $g h$ , meet at  $l$ , and of  $g h$  and  $i k$  at  $m$ ; the eye being at  $n$ , in or near the focus of the eye-glass  $i k$ , on the other side. Then it is plain, that these pencils of rays which flow from the object  $A B$ , and pass through the object-glass  $c d$ , will meet and form an inverted image  $C F D$  in the focus of that glass; and the image being also in the focus of the glass  $e f$ , the rays of the pencils will become parallel, after passing through that glass, and cross at  $l$ , in the focus of the glass  $e f$ ; from whence they pass on to the next glass  $g h$ , and by going through it, they are converged to the points in its other focus, where they form an erect image  $E m F$ , of the object  $A B$ ; and as this image is also

in the focus of the eye-glass  $i k$ , and the eye on the opposite side of the same glass; the image is viewed through the eye-glass in this telescope, in the same manner as through the eye-glass in the former one, only in a contrary position; that is, in the same position with the object.

The three glasses next the eye have all their focal distances equal; and the magnifying power of this telescope is found the same way as that of the last above, viz. by dividing the focal distance of the object-glass  $c d$  by the focal distance of the eye-glass  $i k$ , or  $g h$ , or  $e f$ , since all these three are equal.

When the rays of light are separated by refraction, they become coloured; and if they be united again, they will be a perfect white. But those rays which pass through a convex glass, near its edges, are more unequally refracted than those nearer the middle of the glass. And when the rays of any pencil are unequally refracted by the glass, they do not all meet again in one and the same point, but in separate points; which make the object indistinct, and coloured about the edges. The remedy is, to have a plate, with a small round hole in its middle, fixed in the tube at  $m$ , parallel to the glasses. For the wandering rays about the middle of the glasses will be stopped by the plate from coming to the eye; and none admitted but those which come through the middle of the glass, or at least at a good distance from its edges, and pass through a hole in the middle of the plate. But this circumscribes the image, and lessens the field of view, which would be much larger if the plate could be dispensed with.

Besides the telescopes described before, there is also one called a *binocular*, or *double telescope*.

This is no more than two equal telescopes set in a frame, parallel to one another; and these may be set at a proper distance from one another, by the help of screws; and that distance is to be the same as the distance of the two pupils of the eyes. When that is adjusted, a person is to look through them both at once; through one with each eye, to any object, which will then be seen by both eyes, and appear far brighter than through a single telescope.

Telescopes, in general, represent terrestrial objects as if nearer; and this nearness, or seeming approach of the object, is as the magnifying power of the telescope. Thus, looking at a man one hundred yards off, with a telescope that magnifies one hundred times, the man will appear to be only a yard off.

The magnifying power of a telescope will be found, if you make two equal circles of paper of an inch diameter or more, and fix one of them upon a wall one hundred or two hundred yards distant; and the other at a small distance, in a line with the first. Then look at the farther circle through the telescope with one eye, and at the near circle with the other eye naked. Move the near circle (or else the telescope) backward and forward, until the two circles appear equal, or coincide. Then measure the two distances, from the eye-glass of the telescope to the two circles; divide the greater distance by the less, and you have the magnifying power of the telescope.

There is no better way for trying the *goodness of an object-glass* than putting it in a tube, and trying it with several small eye-glasses, by looking at several distant objects, and particularly at the title-page of a book; for that glass which repre-

sents objects the most bright and distinct, and bears the greatest aperture, and the shortest eyeglass, without colouring or dimness, is the best glass.

*The Reflecting Telescope.*—The great inconvenience attending the management of long telescopes of the refracting kind has brought them too much into disuse since the reflecting telescope was invented; for one of this sort, six feet in length, magnifies as much as one of the other at an hundred. It was invented by Sir Isaac Newton; but has received considerable improvements since his time; and is now generally constructed in the following manner, which was first proposed by Dr. Gregory.

At the bottom of the great tube  $T T T T$  (Plate 17. fig. 1.), is placed the large concave mirror  $D U V F$ , whose principal focus is at  $M$ ; and in its middle is a round hole,  $P$ , opposite to which is placed the small mirror  $L$ , concave toward the great one, and so fixed to a strong wire  $M$ , that it may be moved farther from the great mirror, or nearer to it, by means of a long screw on the outside of the tube, keeping its axis still in the same line,  $P m n$ , with that of the great one. Now, since in viewing a very remote object, we can scarcely see a point of it but what is at least as broad as the great mirror, we may consider the rays of each pencil, which flow from every point of the object, to be parallel to each other, and to cover the whole reflecting surface  $D U V F$ . But, to avoid confusion in the figure, we shall only draw two rays of a pencil flowing from each extremity of the object into the great tube, and trace their progress through all their reflections and refractions.

tions, to the eye  $f$ , at the end of the small tube  $tt$ , which is joined to the great one.

Let us then suppose the object  $A B$  to be at such a distance, that the rays  $C y$  flow from its lower extremity  $B$ , and the rays  $E$  from its upper extremity  $A$ . Then the rays  $C$ , falling parallel upon the great mirror at  $D$ , will be thence reflected, by converging in the direction  $D G$ ; and by crossing at  $I$  in the principal focus of the mirror, they will form the upper extremity  $I$ , of the inverted image  $I K$ , similar to the lower extremity  $B$  of the object,  $A B$ : and passing on the concave mirror  $L$ , (whose focus is at  $n$ ) they will fall upon it at  $g$ , and be thence reflected converging, in the direction  $g N$ , because  $g m$  is longer than  $g n$ ; and passing through the hole  $P$  in the large mirror, they would meet somewhere about  $r$ , and form the lower extremity  $d$  of the erect image  $a d$ , similar to the lower extremity  $B$  of the object  $A B$ . But by passing through the plano-convex glass  $R$  in their way, they form that extremity of the image at  $b$ . In like manner the rays  $E$ , which come from the top of the object  $A B$ , and fall parallel upon the great mirror at  $F$ , are thence reflected converging to its focus, where they form the lower extremity  $K$  of the inverted image  $I K$ , similar to the upper extremity  $A$  of the object,  $A B$ ; and passing on to the small mirror  $L$ , and falling upon it at  $h$ , they are thence reflected in the converging state  $h O$ ; and going on through the hole  $P$  of the great mirror, they would meet somewhere about  $q$ , and form there the upper extremity  $a$  of the erect image,  $a d$ , similar to the upper extremity  $A$  of the object,  $A B$ ; but by passing through the convex glass  $R$  in their way, they meet and cross sooner,

as at  $a$ , where that point of the erect image is formed. The like being understood of all those rays which flow from the intermediate points of the object, between  $A$  and  $B$ , and enter the tube  $TT$ ; all the intermediate points of the image between  $a$  and  $b$ , will be formed; and the rays passing on from the image through the eye-glass  $S$ , and through a small hole  $e$ , in the end of the lesser tube  $tt$ , they enter the eye  $f$ , which sees the image  $ad$  (by means of the eye-glass) under the large angle  $ced$ , and magnified in length, under that angle, from  $c$  to  $d$ .

In the best reflecting telescopes, the focus of the small mirror is never coincident with the focus  $m$  of the great one, where the first image  $IK$  is formed but a little beyond it (with respect to the eye), as at  $n$ ; the consequence of which is, that the rays of the pencils will not be parallel after reflection from the small mirror, but converge so as to meet in points about  $q, e, r$ ; where they will form a larger upright image than  $ad$ , if the glass  $R$  were not in their way: and this image might be viewed by means of a single eye-glass properly placed between the image and the eye; but then the field of view would be less, and, consequently, not so pleasant; for which reason the glass  $R$  is still retained, to enlarge the scope or area of the field.

To find the magnifying power of this telescope, multiply the focal distance of the great mirror by the distance of the small mirror from the image next the eye; and multiply the focal distance of the small mirror by the focal distance of the eye-glass; then divide the product of the former multiplication by the product of the latter, and the quotient will express the magnifying power.

We shall here state the dimensions of one of Mr. Short's reflecting telescopes, as described in Dr. Smith's optics.

The focal distance of the great mirror is 9.6 inches, its breadth 2.3; the focal distance of the small mirror 1.5, its breadth 0.6; the breadth of the hole in the great mirror 0.5; the distance between the small mirror and the next eye-glass 14.2; the distance between the two eye-glasses 2.4; the focal distance of the eye-glass next the metal 3.8; and the focal distance of the eye-glass next the eye 1.1.

One great advantage of the reflecting telescope is, that it will admit of an eye-glass of a much shorter focal distance than a refracting telescope will; and, consequently, it will magnify so much the more; for the rays are not coloured by a reflection from a concave mirror, if it be ground to a true figure, as they are by passing through a convex glass, let it be ground ever so true.

The difficulties which attend this instrument are, the tarnishing of the metallic speculum, and the very great accuracy required in giving it the true figure; for an error in a reflecting surface affects the direction of the rays much more than a like error in a refracting surface. An alloy of metals is made for forming the speculum; but it has been found that platina is the best substance known for this purpose, as it never tarnishes. It is, however, extremely difficult to work, and, consequently, has been hitherto very little used.

The adjusting screw on the outside of the great tube fits this telescope to all sorts of eyes, by bringing the small mirror either nearer to the eye, or removing it farther; by which means the rays



are made to diverge a little for short-sighted eyes, or to converge for those of a long sight.

The nearer an object is to the telescope, the more its pencils of rays will diverge before they fall upon the great mirror, and, therefore, they will be longer off meeting in points after reflection; so that the first image I K, will be formed at a greater distance from the large mirror, when the object is near the telescope, than when very remote. But as this image must be formed farther from its small mirror than its principal focus  $n$ , this mirror must be always set at a greater distance from the large one in viewing near objects, than in viewing remote ones: and this is done by turning the screw on the outside of the tube, until the small mirror be so adjusted, that the object (or rather its image) appears perfect.

In looking through any telescope towards an object, we never see the object itself, but only that image of which is formed next the eye in the telescope; for, if a man hold his finger or a stick between his eye and an object, it will hide part, if not the whole of the object from his view. But if he tie a stick across the mouth of a telescope, before the object-glass, it will hide no part of the imaginary object he saw through the telescope before, unless it cover the whole mouth of the tube: for all the effect will be to make the object appear dimmer, because it intercepts part of the rays. Whereas, if he put only a piece of wire across the inside of the tube, between the eye-glass and his eye, it will hide part of the object which he thinks he sees: which proves that he sees not the real object, but its image. This is also confirmed by means of the small mirror L, in the reflecting telescope, which is made of opaque metal,

and stands directly between the eye and the object towards which the telescope is turned; and will hide the whole object from the eye at  $e$ , if the two glasses R and S are taken out of the tube.

Herschell chiefly makes use of a Newtonian reflector, the focal distance of whose great mirror is 7 feet, its aperture 6.25 inches, and powers 227 and 460 times; though sometimes he uses a power of 6,450 for the fixed stars; but his great telescope is four feet in diameter, and 40 feet in length.

If the metals of a Newtonian telescope are worked as exquisitely as those in Herschell's seven feet reflector, the highest power that such a telescope should bear, with perfect distinctness, will be given by multiplying the diameter of the great speculum by 74; and the focal distance of the single eye-glass may be found by dividing the focal distance of the great mirror by the magnifying power; thus 6.25 multiplied by 74, is 462, the magnifying power.

*Acromatic Telescopes.* — Since the construction of a telescope consists in nothing more than viewing by means of a microscope or eye-glass, the image which is formed in the focus of the object-glass, it may seem easy to make a telescope with a given object-glass, that shall magnify in any assignable degree. For if the eye-glass be rendered more and more convex, the eye may be permitted to approach nearer and nearer to the image; and, consequently, to view it under an angle of apparent magnitude that shall be greater and greater, as required. But this is unattainable on two several accounts. The first is, that spherical surfaces do not refract the rays of light accurately to a point, as has been already observed; and the second and principal reason is, that the rays of

compounded light, being differently refrangible, come to their respective foci at different distances from the glass, the more refrangible rays converging sooner than those which are less refrangible. This is confirmed by experiment: for a paper painted entirely red, and properly illuminated, will cast its image by means of a lens, on a screen at a greater distance than will another blue paper by the same lens in like circumstances. And here it may be noted, that the lens proper for this experiment must be very flat, or a portion of the surface of a large sphere. Hence the image of a white object may be said to consist of an indefinite number of coloured images, the violet being nearest and the red farthest from the lens, and the images of intermediate colours at intermediate distances. The aggregate or image itself, must, therefore, be in some degree confused, and this confusion being very much increased by the magnifying power or eye-glass, renders it necessary to use an eye-glass of a certain limited convexity to a given object-glass. For which reason, if it be required to construct a telescope that shall magnify objects in a greater degree than a given telescope, the object-glass must be less convex, and of consequence its focal distance longer.

It is also necessary to limit the aperture of the object-glass to exclude those rays which are incident at too great distances from the centre; for those, being more refracted, are more particularly subject to the irregularities which arise either from the figure of the glass or the unequal refraction of light.

The great difficulty of managing the longer telescopes occasioned the philosophic world to fix

their thoughts upon the means of converging the rays of light without separating them into their component colours. The best method of effecting this has been accomplished by Dollond.

This invention consists of a double or treble object-glass; the double object-glass consists of a double concave of white flint, and a double convex of crown-glass. The parts of the lenses, which are of the same side of the centres, may be conceived to act like two prisms, which refract contrary ways; and if the excess of refraction in the crown-glass be such as to destroy the divergency of colour caused by the flint-glass, the incident ray will be refracted without any production of colour: the same is true of all the incident rays, and, consequently, the image formed in the focus of this compound object-glass will be free from colours; or, in other words, by means of the different refractive power of these two sorts of glass and their unequal figure, it comes to pass that all the rays of light incident upon those glasses from distant radiant objects, will pass through them in such a manner, that whatever aberration is occasioned in the heterogeneal rays in refraction through the first glass, is so far corrected by the second, that those rays emerge from it nearly parallel among themselves, and are converged to one focus, forming an image not sensibly compounded or coloured, and, therefore, are more perfect and distinct. It will, therefore, admit a much larger aperture, and, of course, a greater magnifying power than the common refracting telescopes possibly can: if the telescope be short, the convexity of the lenses will be considerable; and, in such cases, it is most convenient to combine three

lenses, one concave of white flint-glass between two convex of crown-glass; but still, where a great magnifying power is wanted, recourse must be had to reflecting telescopes.

The greatest impediment to the construction of large acromatic telescopes, is the want of a flint-glass of an uniform density. Fortunately, for Dollond, he met with a quantity of this kind of glass when he began to make acromatic telescopes; but the attempts of many ingenious chemists have since been exerted to make it, without much success.

### *The Multiplying Glass.*

The *multiplying-glass* is made by grinding down the round side,  $h i k$ , of a convex glass  $A B$ , into several flat surfaces, as  $h b$ ,  $b d$ ,  $d k$ . An object  $C$  (Plate 15. fig. 6.,) will not appear magnified, when seen through this glass, by the eye at  $H$ ; but it will appear multiplied into as many different objects as the glass contains plane surfaces. For, since rays will flow from the object  $C$ , to all parts of the glass, and each plane surface will refract these rays to the eye, the same object will appear to the eye in the direction of the rays, which enter it through each surface. Thus a ray  $C i H$ , falling perpendicularly on the middle surface, will go through the glass to the eye, without suffering any refraction; and will, therefore, show the object in its true place at  $C$ : whilst a ray  $c b$ , flowing from the same object, and, falling obliquely on the plane surface  $b h$ , will be refracted in the direction  $b e$ , by passing through the glass; and, upon leaving it, will go on to the eye in the direction of  $e H$ ; which will cause the same object  $C$  to appear also

at E, in the direction of the ray H *e*, produced in the right line H *e* E. And the ray C *d*, flowing from the object C, and falling obliquely on the plane surface *d k*, will be refracted to the eye at H; which will cause the same object to appear at D, in the direction H D. If the glass be turned round the line *c* H, as an axis, the object C will keep its place, because the surface *b d* is not removed; but all the other objects will seem to go round C, because the oblique planes, on which the rays *a b c d* fall, will go round by the turning of the glass.

### *The Camera Obscura.*

The camera obscura is made by a convex glass C D (Plate 17. fig. 2.), placed in a hole of a window-shutter. Then, if the room be darkened so that no light can enter but what comes through the glass, the pictures of all the objects (as fields, trees, buildings, men, cattle, &c.) on the outside, will be shown in an inverted order, on a white paper, placed at G H in the focus of the glass; and will afford a most beautiful and perfect piece of perspective or landscape of whatever is before the glass, especially if the sun shine upon the objects.

If the convex glass C D be placed in a tube, in the side of a square box, within which is the plane mirror E F, reclining backwards, in an angle of forty-five degrees from the perpendicular *k q*, the pencils of rays flowing from the outward objects, and passing through the convex glass to the plane mirror, will be reflected upwards from it, and meet in points, as I and K, at the same distance that

they would have met at  $H$  and  $G$ , if the mirror had not been in the way, and will form the aforesaid images, on an oiled paper stretched horizontally in the direction  $I K$ ; on which paper the outlines of the images may be easily drawn with a black lead pencil; and then copied on a clean sheet, and coloured, as the objects themselves are by nature. In this machine it is usual to place a plain glass, unpolished, in the horizontal situation  $I K$ , which glass receives the images of the outward objects; and their outline may be traced upon it by a black lead pencil.

The tube in which the convex glass  $C D$  is fixed must be made to draw out, or push in, so as to adjust the distance of that glass from the plane mirror, in proportion to the distance of the outward objects; which the operator does, until he sees their images distinctly painted on the horizontal glass at  $I K$ .

The forming a horizontal image, as  $I K$ , of an upright object  $A B$ , depends upon the angles of incidence of the rays upon the plane mirror  $E F$  being equal to their angles of reflection from it. For, if a perpendicular be supposed to be drawn to the surface of the plane mirror at  $e$ , where the ray  $A a C e$  falls upon it, that ray will be reflected upwards in an equal angle with the other side of the perpendicular, in the line  $e d I$ . Again, if a perpendicular be drawn to the mirror from the point  $f$ , where the ray  $A b f$  falls upon it, that ray will be reflected in an equal angle from the other side of the perpendicular, in the line  $f h l$ . And, if a perpendicular be drawn from the point  $g$ , where the ray  $A c g$  falls upon the mirror, that ray will be reflected in an equal angle from the other side of the perpendicular, in the line  $g i l$ . So that all

the rays of the pencil  $abc$ , flowing from the upper extremity of the object  $AB$ , and passing through the convex glass  $CD$ , to the plane mirror  $EF$ , will be reflected from the mirror, and meet at  $I$ , where they will form the extremity  $I$  of the image  $IK$ , similar to the extremity  $A$ , of the object  $AB$ . The like is to be understood of the pencil  $qrs$ , flowing from the lower extremity of the object  $AB$ , and meeting at  $K$  (after reflection from the plane mirror), forming the extremity  $K$  of the image, similar to the extremity  $B$  of the object; and so of all the pencils that flow from the intermediate points of the object to the mirror through the convex glass. This may be further improved, by placing a convex lens of six inches focal distance, and four inches diameter, or more, if it be required longer, between the mirror and the ground glass; and though this will reduce the picture, yet it will be more illuminated, and afford a pleasanter view.

Portable cameras are made, in which the objects are represented upon a paper laid flat, which is much more convenient for drawing. The sides of the box are made to fold and shut up like a book. To view the picture, the face is applied to an opening made for that purpose; and for tracing, the hand is put through a cloth sleeve, fastened to another opening. A mahogany framed head with mirror and lenses, suitable to the distance from about six to nine feet, is sometimes made to be applied to the roof of a house commanding an extensive prospect: the head being contrived to turn round in a horizontal direction. This instrument can, by any intelligent carpenter, be easily applied to the roof, to be put in and taken out occasionally. A round table, of about three feet in diameter,



with a screw pillar to raise or depress its surface for adjusting it properly, according to the focal distance of the lens, or distances of the objects, will be necessary. Its surface should not be flat, but curved to the segment of a sphere, according to the focus of the lens and distance of the objects. The representation of distant objects in this manner will afford the highest pleasure and entertainment: and if objects in motion, such as carriages, horses, ships, &c, favourably illuminated by the sun, present themselves, their pictures will be formed in the most exquisite manner.

The *solar telescope* is a curious instrument, and is applied to use in the following manner: A scioptric ball and socket being fastened against a hole in the window-shutter in a darkened chamber, place the end of a common refracting telescope with its object-glass and eye-glass into the cylindrical hole of the scioptric ball, and draw out the tube to its proper length; this being done, the telescope and ball are moved about until it receives the sun-beams perpendicular on the object-glass through the cylindrical hole of the ball; the tube with the eye-glass is then to be adjusted by moving it either in or out, until the image of the sun, formed on a white plane or screen, is very distinct, large, and luminous.

In this manner, the sun's face is viewed without offence to the eyes, and whatever changes happen thereon may be most accurately observed; the spots, which are seldom seen, even when viewed through small telescopes in the common way, are here conspicuous, and easy to be observed, with all the different circumstances of the spots beginning to appear, their increase, division of one into

many, or the uniting of many into one, their magnitude, decrease, and disappearance.

An eclipse of the sun may, by the solar telescope, be viewed to the greatest advantage, we having it in our power to represent the face of the sun as large as we please, consequently, the eclipse proportionally conspicuous; the circle of the sun's disk may be so divided by lines and circles drawn thereon, that the quantity of the eclipse intimated in digits, may this way be exactly determined; also the exact time of the beginning, middle, and end of it, for determining the longitude. The transits of Mercury and Venus over the face of the sun are exhibited most satisfactorily; the planets appear truly round, well defined, and very black: their comparative diameters to that of the sun, the direction of their motion, and the times of ingress and egress, are here viewed to the greatest perfection.

The *heliostata*, to take off the inconveniences which arise from the motion of the earth, in making experiments on the solar light, was an excellent invention of Dr. Gravesande: it consists of two principal parts, each of which consists of many smaller parts. The first is a plain metallic speculum, supported by a stand; the other is a clock, which directs the speculum according to the earth's motion, keeping the sun in the same point of view.

#### *The Magic-lantern, and Phantasmagoria.*

The *magic-lantern* is a small machine which has been generally used for amusing children, by mag-

nifying paintings on glass, and throwing their images upon a white screen in a darkened chamber. But it is capable of being employed for more important purposes, by using such figures as will explain the principles of astronomy, botany, &c. Its construction is very simple; it consists of a tin lanthorn, within which is a lamp, whose light passes through a great plano-convex lens placed in a tube fixed in the front. This strongly illuminates the small transparent painting on glass placed before the lens in an inverted position; another tube, containing a convex lens, slides within the other, so as to adjust the focal distances of the glasses. The illumination is often increased by means of a convex mirror placed at the back of the lamp. To render the picture distinct, no light should fall upon it but what passes through the lens.

The exhibition called the *Phantasmagoria*, which lately excited so much admiration, is nothing more than a magic lanthorn constructed in a peculiar manner. In the common lanthorns, the figures are painted on the glass, but all the rest of the glass is left transparent; consequently, the image on the screen is a circle of light having a figure on it. But in the phantasmagoria, all the glass is made opaque, except the figure only, which being painted in transparent colours, the light shines through it: for this reason, therefore, no light can come upon the screen but what passes through the figure itself; consequently, you have upon the screen a figure only, without any circle of light as in the common magic-lanthorn.

Instead, also, of the representation being made upon a wall or a sheet, as is usually the case, it is thrown upon a thin screen of silk placed between

the lanthorn and the spectator. The appearance of the image approaching and receding is owing simply to removing the lanthorn farther from the screen or bringing it nearer to it: for the size of the image must increase, as the lanthorn is carried back, because the rays come in the form of a cone; and, as no part of the screen can be seen, the figure appears to be formed in the air; to move farther off when it becomes smaller, and to come nearer as it increases in size, though, in reality, it is still at the same distance.

## ELECTRICITY.

THE term electricity is derived from *electron*, the Greek word signifying amber. The ancients had observed, that when a piece of amber was rubbed, it acquired the property of attracting straws and other light substances.

Dr. Gilbert, in 1600, discovered that this property was also possessed by many other bodies, particularly sealing-wax, sulphur, and glass. Boyle added to the list of such substances. Otto Guericke, the inventor of the air-pump, first mounted a globe of sulphur on an axis, and by whirling it round, excited this power more strongly than had formerly been done, and gave rise to the first electrical machines. Mr. Hawksbee, in 1709, was the first person who made an electrical machine with a glass globe; since which time many philosophers have added to the discoveries in electricity, particularly Dr. Franklin, Dr. Priestley, &c.

To observe the phenomena of electricity in a simple and easy manner, rub a large stick of sealing-wax with a piece of dry flannel, or a glass rod or tube with a piece of dry silk; the sealing-wax and glass will attract light substances, and also give out a cracking noise; and in the dark they will exhibit distinct sparks of light. These sparks

consist of the electricity which is thus excited. Many bodies are capable of thus exhibiting electrical appearances when rubbed; the chief of these are glass, amber, sealing-wax, resin, sulphur, hair, wax, the precious stones, &c. from which they are called *electrics*. On the contrary, such substances as are not capable of being excited, are called *non-electrics*.

The explanation of these phenomena is as follows: When the square piece of wood L M I K (which may represent the shutter of a window), is fixed into the hole, so that the wire I K stands in the dotted representation L M, then the metallic communication from H to N is complete, and the instrument represents a house furnished with a proper metallic conductor; but if the square piece of wood L M I K is fixed so that the wire I K stands in the direction I K, as represented in the figure, then the metallic conductor H N from the top of the house to its bottom is interrupted at L M; in which case the house is not properly secured.

Fix the piece of wood L M I K, so that its wire may be as represented in the figure, in which case the metallic conductor H N is discontinued. Let the ball G be fixed at about half an inch perpendicular distance from the ball H; then, by turning the glass pillar C, remove the former ball from the latter; by a wire, or chain, connect the wire E F with the wire Q of the jar P; and let another wire, or chain, fastened to the hook O, touch the outside coating of the jar. Connect the wire Q with the prime conductor, and charge the jar: then, by turning the glass pillar D C, let the ball G come gradually near the ball H, and when they are arrived sufficiently near one another, you will observe that the jar explodes, and the piece of wood

cited to exhibit electricity. The best conductors are the metals and water.

The equilibrium in the natural electricity of bodies is disturbed most, when an electric and a non-electric are rubbed together. Thus, if glass be rubbed by a piece of flannel, the electricity which is excited will leave the flannel, and be accumulated upon the glass, which will then have more than its natural quantity. If then a conducting body, as the finger, be presented to the glass, the superabundant quantity in the glass will pass into the finger, since there is a tendency in all bodies to preserve the equilibrium of the electric fluid.

It is only during this passage or discharge from one body to another, that electricity is rendered visible and luminous.

When a body has more than its natural quantity of this fluid, it is said to be *positively* electrified, and the electricity it contains is called positive electricity; and when it has less than its natural share, it is said to be *negatively* electrified. When a conductor is so surrounded by non-conductors, that the electric fluid cannot pass from it to the earth, it is said to be *insulated*, as a piece of metal supported upon a glass pillar, for instance.

As the quantity of electricity that could be collected by exciting rods of glass or sealing-wax is very small, machines have been contrived for rubbing together electrics and non-electrics, which are called *electrical machines*.

Plate 18. fig. 1. represents an electrical machine of the most simple construction. A B is a strong board which supports all the parts of the machine, and which is fastened to a steady table by means of one or more iron or brass clamps. The glass cylinder D, quite dry and clean in its inside, is

about ten inches in diameter, and is furnished with two caps, either of wood or brass, into which its two short necks are firmly cemented. Each of those caps has a pin, or pivot, which turns in a hole through a wooden piece that is cemented on the top of a glass-pillar, as at E and F, on the glass-pillars E G, F H, which are firmly fixed to the bottom board A B. One of those pins passes quite through the wooden piece at E, and has a square termination to which the winder I is applied, and secured on by means of a screw-nut. By this winder the cylinder is turned round; part of it is made of glass, in order the more effectually to prevent the escape of the electric fluid from the cylinder. K is the rubber, which is made of silk, or leather stuffed with hair, and L is a flap of silk fastened to it, and covering part of the cylinder, to prevent the dispersion and escape of the electric fluid. This rubber or cushion is fastened to a spring which proceeds from a socket cemented on the top of the glass-pillar M. The lower part of the pillar is fixed into a small board which slides upon the bottom board of the machine, and by means of a screw-nut and a slit, may be fixed more or less forward, in order that the rubber may press more or less upon the cylinder. N is a glass-pillar which is fixed upon the bottom-board, and supports the prime conductor O P, of hollow brass or tin-plate, which has the collector or pointed wires at Q, and a knobbed wire at P. From this brass knob R, a longer spark may be drawn than from any other part of the conductor. But this knobbed wire is only screwed into the conductor, and may be easily removed from it.

The simple rubber, such as has been described, will produce a very slight excitation of the cylin-



der; but its power is vastly increased by laying upon it a little amalgam of zinc.

Globes of glass have also been used for electrical machines; and sometimes multiplying-wheels have been employed for producing a greater velocity of rotation, but these have not been found to answer so well as cylinders.

Plates of glass are also used for this purpose; and when properly constructed, appear to be the most powerful of any. They are more compact, and are less liable to be affected by damp. The simplest construction of the *plate machine* is represented Plate 18. fig. 2. A B C D M is a wooden frame, to which the four rubbers are affixed by means of the screws *g g*, and may be made to bear with proper pressure upon the circular glass-plate H K. This plate has a hole through its middle, to which an axis is firmly fixed, and is turned by the winch L. The prime conductor I, which may be fixed on the stand of the machine or not, as thought proper, has a branched termination, which points at the extremities, which collect the electric fluid from the forepart of the glass plate.

Some plate machines have been made with two glass plates and eight rubbers, and when they are constructed in the best manner, as by Mr. Cuthbertson, their power is very great. Indeed, the most powerful electrical machine now extant is one of this construction made by the above-mentioned instrument-maker, at Haerlem. This machine consists of two circular plates, each 65 inches in diameter, fixed on an axis parallel to each other, and  $7\frac{1}{2}$  inches asunder. Each plate is excited by four rubbers: the prime conductor is divided into two branches, which enter between the plates, and

by means of points, collect the electric fluid from their inner surfaces only.

When the cylinder of the electrical machine is whirled round, the friction of the glass against the rubber makes the electric fluid which was in the rubber pass to the glass, from whence it is conveyed to the prime conductor, the points of which are presented to every part of the globe in succession: and, as the friction is continued, there will, by this means, be a constant supply of the electric matter to the prime conductor, which, when other bodies are presented to it, will keep discharging all the while in visible sparks. The hand, in the case of a glass tube, and the rubber in the electrical machine, which had parted with their share of the electric fluid to the glass against which they were rubbed, receive an immediate supply from the conducting substances in contact with them; and these are again supplied by the general mass of the fluid that is lodged in the earth.

### *Electrical Attraction and Repulsion.*

Two bodies possessing different states of electricity, that is, one being *positively*, and the other *negatively* electrified, attract each other; but two bodies which are either both positively or both negatively electrified, repel each other.

A convenient way of showing electrical attraction and repulsion, is by fastening two small balls made of the pith of elder of the size of peas, by threads of three or four inches long, to a small stem, and putting them on the prime conductor: when the machine is turned, the balls repel each

other, because the same kind of electricity is communicated to both.

If both balls be electrified by touching them with sealing-wax, they will repel each other; and if they be both touched by excited glass they will repel each other: but if one ball be electrified by glass and the other with sealing-wax, they will attract each other. Hence there seems some difference between the electricity excited by the sealing-wax and the glass. Formerly it was supposed that this was owing to two sorts of electricity, and they were accordingly called *vitreous* and *resinous* electricity. But the explanation of Dr. Franklin is now generally adopted; viz. that these phenomena are owing to the electricity of sealing-wax being negative, and that of glass being positive.

When glass is rubbed with silk, the natural electricity of the silk leaves it and is accumulated on the glass: but when sealing-wax is rubbed with flannel, the electricity is accumulated on the flannel at the expense of the sealing-wax. The electricity, therefore, in these cases, of the silk and the sealing-wax, and that of the flannel and the glass, are the same.

If a bundle of hairs or feathers be hung upon the prime conductor, the moment they are electrified by turning the wheel of the machine, they begin to fly from one another; so that some of of them will stand quite erect.

A large plummy feather grows beautifully turgid when it is electrified, expanding its fibres in all directions.

When the conductor is discharged by the approach of a conducting substance, as the finger, or a piece of metal, the fibres collapse, because then they are

deprived of their electricity and reduced to the natural state: but they repel each other again, as soon as the finger is withdrawn, being again electrified.

As all bodies possessed of the same kind of electricity, that is, either all positive or all negative, repel each other in proportion to the superabundant quantity they contain, upon this principle, instruments called *electrometers* are constructed for measuring the degree in which a body is electrified.

Fig. 6. represents Mr. Henley's quadrant electrometer; it may be fixed upon the prime conductor, which generally has a hole in it for that purpose, or upon any other apparatus that may be thought necessary. It consists of a very light rod, and pith ball, A, turning on the centre of a semicircle B, so as always to keep almost close to its graduated limb, c is the pillar that supports the semicircle and rod. The whole instrument may be made of wood or ivory; but is found most perfect when the pillar and index, or rod, are made of box, and well smoothed with emery paper, the ball of pith, and the graduated part of the semicircle ivory, as the divisions are more legible than in wood.

The moment this instrument begins to be electrified, the rod is repelled by the pillar, and consequently begins to move over the edge of the semicircle, showing to the greatest precision, the degree to which the prime conductor is electrified; or how high any jar or battery is charged.

*Bennet's electrometer*, represented Fig. 4., is by far the most delicate of any yet invented, for distinguishing small quantities of electricity. It

consists of two slips of leaf-gold A, suspended in a glass B. The foot C may be made of wood or metal: the cup D of metal. The cup is made flat on the top, that objects to be electrified may be conveniently placed upon it. The cup is about an inch wider in diameter than the glass, and its rim about three quarters of an inch broad, which hangs parallel to the glass, to turn off the rain, and keep it sufficiently insulated. Within this is another circular rim, about half as broad as the other, which is lined with silk or velvet, and fits close upon the outside of the glass. Within this rim is a tin tube, hanging from the centre of the cap, somewhat longer than the depth of the inner rim. In the tube a small peg is placed, and may be occasionally taken out. To the peg, which is made round at one end and flat at the other, the slips of leaf-gold are fastened with paste, gum-water, or varnish. These slips suspended by the peg, and that in the tube fast to the centre of the cap, hang in the middle of the glass, about three inches long, and a quarter of an inch broad. On one side of the cap there is a small hole to place wires in. It is evident, that, without the glass, the leaf-gold would be so agitated by the least motion of the air, that it would be useless: and if the electricity should be communicated to the surface of the glass, it would interfere with the repulsion of the leaf-gold; therefore two long pieces, H H, of tin-foil are fastened with varnish on opposite sides of the internal surface of the glass, where the leaf-gold may be expected to strike, and in connexion with the foot. The upper end of the glass is covered and lined with sealing-wax as low as the outermost rim, to make its insulation more perfect.

The sensibility of this instrument is very surprising. The brush of a feather, the throwing of chalk, hair-powder, or dust, against its cap, evince strong signs of electricity. The electricity of vapour is elegantly shown by pouring a tea-spoonful of water on an ignited coal, placed in a metallic cup upon the cap of this electrometer.

This instrument is also used for distinguishing the kind of electricity possessed by any body. For when the body is placed upon the cap, so as to make the gold leaves diverge, if a stick of sealing-wax be brought near to it, and the leaves diverge still more, then the electricity is *negative*; but if they collapse, then the electricity is *positive*. The reason of this is, that the electricity of sealing-wax being negative, more of the same kind of electricity is added, if the electricity of the body under examination be also negative; but if it be positive, then it is neutralized by the negative electricity of the sealing-wax.

#### *Of the Electric Spark.*

When a piece of metal, or any other good conducting substance, is presented to the charged prime conductor, the electric matter will pass with violence from the one to the other: an *electric spark*, with the appearance of fire, will be seen darting between them; and a slight report, which is usually compared to a snapping noise, will be heard.

When any person stands upon the stool with feet made of glass (such as is represented Fig. 7.), and takes in his hand a chain fastened to the prime

conductor, being then insulated, he may be considered as a part of the prime conductor ; and any part of his body will exhibit all the same appearances which the prime conductor itself will do. Thus, if the finger of any person standing upon the floor be presented to him, a spark of fire will seem to issue from him, and both he and the person that receives it will feel a painful sensation, like a pricking ; and the same snapping noise will be heard. Every part of his body will then attract light substances ; and the bits of feathers, or the human figures above-mentioned, cut in paper, and laid on a plate, will perform the same dances that were mentioned before, if the palm of his hand be expanded over them. Also the hairs of his head will repel one another ; and many of them will stand upright. As these electric sparks, which are attended with a sensation moderately painful, will be excited wherever he is touched, or wherever he touches any other person, this experiment will furnish great diversion.

The electric spark has not only the appearance of fire, but is capable of actually setting fire to various substances that are easily inflamed. Thus, if spirits of wine be held in a spoon, and an electric spark be drawn from the spoon so as to pass through any part of the spirits, they will catch fire, and burn as if they had been lighted by a candle. The spoon in which the spirits are contained may either be connected by the prime conductor, and the spark drawn through them by a person standing on the floor ; or the spoon may be held by a person standing on the floor, and the spark be drawn through them by a brass rod, either connected immediately with the prime conductor, or

held in the hand of a person standing on the stool, in the manner mentioned above. It will be more amusing, and the effect will be as certain, if the spark be drawn through the spirits by the end of a person's finger. This experiment succeeds best when the spoon is previously warmed. If a candle be blown out, and an electric spark be immediately drawn through the smoke, it will often be lighted again; but it requires a pretty strong spark, and some degree of dexterity and experience in the operator, to produce this effect with certainty.

Not only are the senses of feeling, seeing, and hearing, affected by electricity, in the manner described above, but it is even sensible to the smell and the taste. If a pointed brass rod be electrified, either by being fastened to the prime conductor, or held in the hand of a person electrified, and another person standing upon the floor present his nose within an inch or two of the point, he will discover a strong and disagreeable smell, like that of burning sulphur; and if he receive the electric effluvia issuing from the point upon his tongue, he will perceive a taste which is manifestly acid.

The electric spark will go to a greater or less distance through the air, in order to reach a conductor, according as its quantity is greater or less; as the parts from which it proceeds, and on which it strikes, are sharper or more blunt, and as the conductor is more or less perfect. The strength of the machine is known from the length and density of the sparks it gives.



*Of the influence of Points in Electricity.*

When a conducting body is made of a pointed form it easily parts with its electricity, and acquires it more easily from another. This is rendered very obvious, if the experiments are made in the dark. If a sharp pointed wire be fixed upon the prime conductor while the machine is in action, the electric matter will be seen issuing from it in the form of a pencil or brush, and of a beautiful bluish colour, and with a kind of rustling noise. But if the wire be held in the hand, and presented to the prime conductor, a brilliant star will be seen upon the point of it, owing to the entrance of the electricity into the point which draws it from the conductor.

If a plate of tin be cut into the form of a star (Fig. 7.), and be supported on its centre by a wire projecting from the prime conductor, as soon as the wheel of the machine is turned, and this apparatus electrified, a flame will appear at the extremity of every angle of the star, which will be very beautiful; and if the star be made to turn swiftly on its centre, an entire circle of fire will be seen in the dark. This experiment will be more surprising, if the operator now and then privately touch the prime conductor, as by this means he may command the appearance or disappearance of the star, or circle of fire, at pleasure.

If two sharp-pointed wires be bent (Fig. 8.), with the four ends at right angles, in the same plane, but pointing different ways, and be made to turn upon the point of wire fixed in the prime conductor; the moment it is electrified, a flame will be seen at the points *a, b, c, d*; and the wires

will, at the same time, turn round in the direction opposite to that to which the points are turned.

If the figures of horses, cut in paper, be fastened upon these wires, and they be so contrived that the points shall be in their tails, the experiment will be more curious; the horses will seem to pursue one another. It is possible to make several of these wires, each having a considerable number of points bent backwards, with horses, &c. fastened to each of them, and turning one above another; and then some of them may be contrived to move faster than the others. They may also be made to move different ways.

By means of the stream of electricity that issues from a point, little models of machinery made of stiff card may be set in motion.

Plate 19. fig. 1., is an orrery for showing the earth's motion round its axis in twenty-four hours, the age of the moon from change to change, and all her various phases during that time. *A* is the horizontal board, or stand, of this machine; and *B* is the great wheel, with 18 floats, or wings, for the electric stream to act upon, and turn the wheel, according to the order of the letters *a, b, c, d*. On the axis of this wheel is a trundle *C* of 8 staves for turning the wheel *F* of 32 teeth, on whose axis is a trundle *G*, of 8 staves, for turning the wheel *H* of 59 teeth, which will go once round in the time the great wheel *A* goes  $29\frac{1}{2}$ . A little hollow globe *D*, representing the earth, with its meridians, &c. is put upon the top of the axis of the great wheel *A*; and on the same axis is the index *E*, which goes round a small dial-plate *e*, of 24 hours, in the time that the earth *D* turns round. An ivory ball, *I*, is placed on the top of the axis of the wheel *H*, half black, half white, to represent the moon; below

which, on the same axis, is an index K, which goes round a small plate *h*, divided into  $29\frac{1}{2}$  equal parts, for the days of the moon's age from change to change. So that, in the time the great wheel A, the earth D, and hour-index E, make  $29\frac{1}{2}$  revolutions, the moon I, and her index K, make only one; and in that time, by showing herself all round to the observers, her different phases are exhibited like those of the real planet.

Having set the orrery near the prime conductor, place a crooked wire from the conductor, so that its point may be even with the great wheel B, and tend to turn it in the direction *a, b, c, d*; turn the glass globe of the electrical machine by the winch, and a stream of fire will issue from the wire to the wheel, and turn the whole of the moveable work; by which means, the earth D will be turned round its axis, from west by south to east; and, in such turn of the earth, the index E will go round all the 24 hours on the dial-plate *e*. In the time the earth and index turn  $29\frac{1}{2}$  times round, the moon I will turn once round her axis, showing all her various phases; and the index K will go over all the  $29\frac{1}{2}$  days of the moon's age on the plate K.

Fig. 3. is another electrical orrery, showing the motion of the sun, earth, and moon. The sun and earth go round the common centre of gravity between them in a solar year; and the earth and moon go round the common centre of gravity between them in a lunar month. The ball S represents the sun, E the earth, and M the moon, connected by wires *a c* and *b d*: *a* is the centre of gravity between the earth and moon. These three balls, and their connecting wires are hung and supported on the sharp point of a wire A, which is

stuck upright in the prime conductor B of the electrical machine; the earth and moon hanging upon the sharp point of the wire *c*, *a*, *e*, in which wire is a pointed short pin, sticking out horizontally at *e*; and there is just such another pin at *d*, sticking out in the same manner, in the wire that connects the earth and the moon.

When the globe of the electrical machine is turned, the above-mentioned balls and wires are electrified; and the electricity, flying off horizontally from the points *c* and *d*, causes S and E to move round their common centre of gravity *a*; and A and M to move round their common centre of gravity *b*. And as E and M are light when compared with S and E, there is much less friction on the point *b*, than upon the point *a*; so that E and M will make many more revolutions about the point *b*, than S and E make about the point *a*. The weights of the balls may be adjusted so that E and M may go twelve times round *b*, in the time that S and E go once round *a*.

Fig. 2. represents a model of a water-mill for grinding corn. A is the water-wheel, B the cog-wheel on its axis, C the trundle turned by that wheel, and D the running mill-stone on the top of the axis of the trundle. It may easily be contrived and turned also by electricity, if, instead of the round plate D for the mill-stone, there be a horizontal wheel on the axis of the trundle C, with spur-cogs, which will turn two trundles placed on its opposite sides; and on the top of the axis of each of these trundles, may be a round plate representing a mill-stone; so that this model has all the working parts of a double water-mill, turning two mill-stones.

Set the mill near the prime conductor, and place the crooked wire, so that its point may be directed towards the uppermost side of the great wheel A. Then turn the glass globe by the winch, and the stream of fire that issues from the point of the wire will turn the wheel; and, consequently, all the other working parts of the mill.

*Of the Leyden Phial, and the Electrical Shock.*

When an electric or non-conducting body is presented to a body containing a super-abundant quantity of electricity, the opposite sides of the electric become possessed of different kinds of electricity; that is, one is positive, and the other negative. Thus, if a plate of glass be brought into contact with the prime conductor, or if a point from the prime conductor be made to touch the glass, one side of the glass becomes positive and the other negative. In this case the glass is said to be charged; and the two kinds of electricity cannot come together to restore the equilibrium, because of the non-conducting quality of the glass.

But if a communication be made between the two sides of the glass by means of a conducting substance, then a discharge will take place from one to the other, the electricity passing through the conducting body. This discharge is called the *electric shock*: because when a living animal forms part of the communication between the two sides of the charged plate, so that the discharge must pass through it, a sudden shock or peculiar sensation is felt.

In order to communicate electricity to every part of the side of a non-conducting substance, it is necessary to bring each part successively in contact with an electrified body.

To avoid this difficulty, it is customary to coat the sides of the non-conductor with some conducting substance, such as tin-foil, by which means the operation of charging and discharging is rendered very easy; for when the electricity is communicated to one part of the coating, it immediately spreads itself through all parts of the electric that are in contact with that coating; and when the discharge is to be made, it will be sufficient to make a communication by means of a conducting substance, between the coatings of both sides.

In coating an electric plate, it is necessary to keep the coatings from coming to the edges of the plate; because, otherwise, the contrary electricity of one side would force its way through the air, round the edge, to the coating of the other side, and thus prevent any charge taking place.

In order to communicate a considerable charge to a plate, it is necessary that the side opposite to that which receives the charge have a communication through conducting substances with the earth; otherwise, only a very small charge can be given.

Those effects take place in the same manner, whether the glass be in the form of a plate, or in any other shape, provided it be sufficiently thin: it being not the form, but the thickness of the glass, that renders it capable of receiving an higher or lower charge. The thinnest glass receives the highest charge, but is more liable to be broken by it; because the attraction of the

electricities of the opposite sides becomes at last powerful enough to force a passage through the glass.

This remarkable phenomenon was first discovered by Von Kleist, Dean of the cathedral of Camin. The account he gave of it is as follows: "When a nail, or a piece of thick brass wire, &c. is put into a small apothecaries' phial and electrified, remarkable effects follow; but the phial must be very dry or warm. I commonly rub it beforehand with a finger, on which I put some pounded chalk. If a little mercury, or a few drops of spirits of wine, be put into it, the experiment succeeds the better. As soon as this phial and nail are removed from the electrifying glass, or the prime conductor to which it hath been exposed, is taken away, it throws out a pencil of flame so long, that with this burning machine in my hand, I have taken above sixty steps, in walking about my room. When it is electrified strongly, I can take it into another room, and there fire spirits of wine with it. If, while it is electrifying, I put my finger, or a piece of gold which I hold in my hand, to the nail, I receive a shock which stuns my arms and shoulders."

This description of the experiment was so imperfect, that it did not succeed with those to whom he communicated it.

A short time after, a similar experiment was made at Leyden, which was attended with the same effects.

When Professor Muschenbroeck was making some electrical experiments with a phial filled with water, Mr. Cuneus happened to hold the glass vessel in one hand, the water of which had a communication

with the prime conductor, by means of a wire. With the other hand, he was disengaging it from the conductor, supposing that the water had received as much electricity as the machine could give it, when he was surprized by a sudden shock in his arms and breast, which he had not in the least expected from the experiment.

It is extremely curious to observe the descriptions which the philosophers who first felt the electrical shock, give of it.

Muschenbroeck, who tried the experiment, says, that he felt himself struck in his arms, shoulders, and breast, so that he lost his breath, and was two days before he recovered from the effects of the blow and the terror. He adds, that he would not take a second shock for the kingdom of France. Many other accounts equally extraordinary were published.

Such was the surprise and terror with which these electricians were struck by a sensation which thousands have since experienced without any disagreeable effects; and it affords us a lesson how far we ought to credit the first accounts of extraordinary discoveries, where the imagination is liable to be affected.

On account of this experiment being first satisfactorily made at Leyden, a bottle coated on the outside and inside, for the purpose of charging and discharging, is called the *Leyden phial*, or *electric jar*.

Plate 19. fig. 4. represents an electric jar of the usual shape. Its mouth is filled with a piece of mahogany, or cork, turned to fit it, and varnished. Through the centre of this, there passes a brass wire with a knob, and having a bit of chain fas-



tened to the lower end, which touches the bottom. To charge this jar, a communication is made between the electrical machine and the brass knob, while the outside of the jar communicates with the earth by the table or the hand. After a few revolutions of the machine, it is charged, and ready to exhibit the usual effects. D is an instrument called a *discharger*, which is used for discharging the jars when required, without the shock passing through any thing besides. It consists of two knobs attached to brass wires, which move round a joint fixed to a glass handle. E is a simpler kind of discharger, consisting only of two knobs, connected by a bent brass wire.

When one of these knobs is applied to the ball on the jar, and the other to the outside coating, it establishes a communication between the outside and inside of the jar, by which the equilibrium is restored, from the superabundant electricity passing with great rapidity from one to the other, and appearing in the form of a vivid flash, accompanied by a loud report, which will be in proportion to the size of the jar, and the degree of the charge. If the discharger is used, and you want to see the flash, it is necessary first to apply one of the knobs to the side that does not communicate with the electrical machine, which is generally the inside; because if the knob be applied first to the side that receives the electricity from the machine, the jar will be discharged by establishing a communication with the other side through the hand and body, which would produce the electric shock.

The most convenient method of receiving the electric shock is to place the jar (after having charged it in the manner mentioned above) upon a piece of chain laid upon the table; then laying one

hand upon the chain, you touch the knob of the jar with a piece of metal held in the other hand.

Any number of persons may receive the shock together, by laying hold of each other's hands; the first person in the row communicating with the outside of the jar, while the last person touches the knob of the jar which is connected with the inside. In this case, every one will receive the shock at the same instant, and nearly in the same degree, though it may produce a greater effect upon some than upon others.

The velocity of the electric fluid in passing from a body charged *positively*, to another charged *negatively*, is beyond all calculation; and from every experiment that has been made, appears to occupy so minute a portion of time, that it cannot be ascertained. It has been sent through a circuit of several miles apparently in an instant, both through water and dry ground.

It was mentioned above, that the strength of the shock depended upon the quantity of coated surface; large jars, therefore, give greater shocks than small ones.

### *The Electrical Battery.*

Several jars may be connected together, by making a communication between all their outsides and all their insides by means of wire or chain. When a number of jars are thus connected, it is called a *battery*.

If a battery is required of no very great power, containing about eight or nine square feet of coated glass, common pint or half-pint phials, such as apothecaries use, may be employed. They

occupy a small space, and, on account of their thinness, hold a very good charge. But when a large battery is required, then these phials cannot be used, for they break very easily; and for that purpose cylindrical glass jars of about fifteen inches high, and four or five inches in diameter, are the most convenient.

When glass plates, or jars, having a sufficiently large opening, are to be coated, the best method is, to coat them with tin-foil on both sides, which may be fixed upon the glass with paste; but in case the jars have not an aperture large enough to admit the tin-foil, then brass-filings, such as are sold by the pin-makers, may be advantageously used; and they may be stuck on with gum-water. Care must be taken that the coatings do not come very near the mouth of the jar, for that will cause the jar to discharge itself. If the coating is about two inches below the top, it will in general do very well; but there are some kinds of glass, especially tinged glass, that, when coated and charged, have the property of discharging themselves more easily than others, even when the coating is five or six inches below the edge. There is another sort of glass, like that of which Florence flasks are made, which, on account of some unvitriified particles in its substance, is not capable of holding the least charge; on these accounts, therefore, whenever a great number of jars are to be chosen for a large battery, it is advisable to try some of them first, so that their quality and power may be ascertained.

Plate 20. fig. 1. is a battery composed of twelve jars, coated in the inside and outside with tin-foil, which altogether contain about twelve feet of coated glass. About the middle of each of these jars is a cork that sustains a wire, which at the top

is fastened round, or soldered to the wire E, knobbed at each end; this connects the inside coatings of three jars; and by four wires, such as F F, the inside coatings of all the twelve jars may be connected together. Each of the wires F has a ring at one end, through which one of the wires E passes; and the other end has a brass knob. If the whole force of the battery be not required, one, two, or three rows of jars may be used at pleasure; for as each of the wires F F is moveable round the wire E which passes through its ring and rests upon the next wire E, it may be easily removed from that, and turned upon the contrary wire E; and thus the communication between one row of jars and another may be discontinued at pleasure.

The square box that contains these jars is of wood lined at the bottom with tin-foil, and having two handles on two opposite sides, by which it may be easily removed. In one side of the box is a hole through which an iron hook passes, that communicates with the metallic lining of the box, and consequently with the outside coating of all the jars. To this hook is fastened a wire, the other end of which is connected with the discharging rod.

The force of accumulated electricity, great as it appears by the experiments performed with a single-coated jar, is very small when compared with that which is produced by a number of jars connected together; and if the effects of a single jar are surprising, the prodigious force of a large battery is certainly astonishing. Experiments of this kind should be conducted with great caution; and the operator ought to be attentive not only to the business in hand, but also to the persons who may

happen to be near him, prohibiting their touching, or even coming too near, any part of the apparatus: for if a mistake in performing other experiments may be disagreeable, those in the discharge of a large battery may be attended with dangerous consequences.

The charge of a large jar, or a battery, sent through a piece of very slender wire, makes it instantly red-hot, melts it, and if the fusion is complete, reduces it into globules of different magnitudes. For this purpose, you need only make the wire a part of the circuit; for instance, place it between the wires of the universal discharger, which will be described afterwards. The fine turnings or shavings of steel, which may be had at the philosophical instrument-maker's, are very easily fused, even by a small shock. But a wire of the fiftieth part of an inch, or upwards, requires a considerable battery to fuse it. The force of a battery may be estimated by the length of wire which its discharge is able to fuse.

Take two slips of common window-glass, about three inches long, and half an inch broad; put a small slip of gold, silver, or brass leaf between them, leaving a little of the metallic leaf out of the glasses at the two ends, and place the glass slips between the boards of the press of the universal discharger; then by connecting the wires of the discharger with the projecting extremities of the metallic leaf, send a charge of a battery through it; the consequence is, that the glasses are generally shattered by it; but whether they are broken or not, they will be found indelibly marked by the metal, which is forced so far into the pores of the glass, as not to be affected even by the menstrua which otherwise are wont to dissolve it.

If gold or silver leaf be put between cards, and a strong charge passed through it, it will be completely fused, and even reduced to the state of an oxide, which will be distinctly marked upon the card.

### *The Electrophorus.*

This simple species of electrical machine consists of two plates (Plate 20. fig. 5.) A and B, made of a circular form, from six to eighteen inches diameter, or upwards. The upper plate is generally made of brass; but a tin plate, with a wire turned in upon its edge, will answer exceedingly well. At the centre of this plate there is a socket O, in which a glass handle I, nine or ten inches long, is fixed. A thin board, covered with tinfoil, and suspended by silken strings, will answer well, when the electrophorus is wanted of a large diameter.

The under plate may be made of glass, sealing-wax, or of the following composition, viz. four parts rosin, three parts pitch, three parts shell-lac, two parts Venice turpentine, melted together over a gentle fire. It may be poured and spread upon a thin linen cloth about one-fourth of an inch thick. The linen cloth must be stretched upon a hoop, and made as tight as possible. If the surface be a little rough, it will be no worse.

The manner of using this machine is as follows: rub the coated side of the under plate A with new fine flannel, or a hare or cat's skin; and when it is excited as much as possible, set it on a table, and place the upper plate upon it, and put your finger on the upper plate; then remove your finger, and take hold of the top of the glass handle I, and apply

it to the knob of a coated jar. Repeat this operation for thirty or forty times, and the jar will become charged.

Cavallo mentions one of the above kind made by him, with which he charged a coated phial several times by once exciting, so strong as to pierce a hole through a card at every discharge.

When a glass is covered with sealing-wax, after it is excited and laid with the waxed side downward, and the glass uppermost, then on making the usual experiment of putting the metal plate on it, and taking the spark, &c. it will be attended with contrary electricity to what it had before.

#### *The universal Discharger.*

This apparatus is of extensive use, and is composed of the following parts: A is a flat board fifteen inches long, four inches broad, and one thick, or thereabouts, which forms the basis of the instrument. B B (Fig. 6.) are two glass pillars, cemented in two holes upon the board A, and furnished at the top with brass caps, each of which has a turning joint, and supports a spring tube, through which the wires D D slide. Each of these caps is composed of three pieces of brass, connected so that the wires D D, besides their sliding through the sockets, have two other motions, viz. an horizontal and vertical one. Each of the wires D D is furnished with an open ring at one end, and at the other end having a brass ball, which, by a short spring socket, is slipped upon its pointed extremity, and may be removed from it at pleasure. E is a strong circular piece of wood, five inches in diameter, having on its surface a slip of ivory inlaid,

and furnished with a strong cylindrical foot, which is fastened in the middle of the bottom board A.

*Atmospheric Electricity.*

The resemblance between an electric spark and lightning is obvious, but the proof of their identity was reserved for Dr. Franklin. He first observed the power of points in drawing off the electricity from bodies at great distances; and thence inferred, that a pointed metallic bar, if raised to a considerable height in the air, would become electrical by communication from the clouds during a thunder-storm.

After having published his hypothesis concerning the identity of electricity with the matter of lightning, he was waiting for the erection of a spire in Philadelphia, to make experiments on the subject, when it occurred to him, that by means of a common kite, he would have a readier and better access to the regions of thunder, than by any spire whatever. He therefore prepared a kite for this purpose, and took it into the fields, attended by his son. The kite being raised, the end of the cord was tied to a small key. One very promising cloud had passed over it without any effect; when, at length, just as he was beginning to despair, he observed some loose threads of the hempen string to stand erect, and to avoid one another, just as if they had been suspended on a common conductor. Struck with this appearance, he immediately presented his knuckle to the key; and let the reader judge of the exquisite pleasure he felt at the moment the discovery was complete. He perceived



a very evident electric spark. Others succeeded, even before the string was wet, so as to put the matter past all dispute; and when the rain had wetted the string, he collected the electricity very copiously. This happened in June, 1752.

The same experiment has been often successfully repeated: but it is not unaccompanied with danger; since frequently such a quantity of electric matter is suddenly brought down, that several persons have been hurt by it, and a professor at St. Petersburg was killed in this manner.

A grand practical application of this discovery has been, to secure buildings from being damaged by lightning.

This great end is accomplished by the cheap, and seemingly trifling apparatus, of a pointed metallic rod, fixed higher than any part of the building, and communicating with the ground, or, rather, the nearest water. This rod the lightning is sure to seize upon, preferably to any other part of the building, unless it be very large and extended; in which case, rods may be erected at each extremity; by which means this dangerous power is safely conducted to the earth, and dissipated without doing any harm to the edifice.

Lofty trees are often struck by lightning; and in a thunder storm it is not safe to seek for shelter under them. In this case the safest place is in the open field. Persons carrying arms or tools have been often killed by lightning, which has been attracted by the metallic substances. When a house is struck, it may be observed that it is by the metallic parts that the lightning makes its way to the earth; frequently by the bell wires which it often melts, and when there is an interruption in the continuity of the conducting substance, it darts to the nearest

conductor, and forces its way, destroying whatever resistance it may meet with.

The effects of the electric matter, when it strikes a building, and the method of preventing it, are exemplified by an instrument called the *thunder-house*, representing the side of a house, either furnished with a metallic conductor, or not. A, (Plate 20. fig. 2.) is a board about three quarters of an inch thick, and shaped like the gable-end of a house. This board is fixed perpendicularly upon the bottom board B, upon which the perpendicular glass pillar C is also fixed, in a hole about eight inches distant from the basis of A. A small hole I L M K, about a quarter of an inch deep, and nearly one inch wide, is made in the board A, and is filled with a square piece of wood nearly of the same dimensions. It should be of rather smaller dimensions, because it must go so easily into the hole, that it may drop off by the least shaking of the instrument. A wire, I K, is fastened diagonally to this square piece of wood. Another wire, L H, of the same thickness, having a brass ball H, screwed on its pointed extremity, is fastened on the board A; so also the wire M N, which is shaped in a ring at N. From the upper extremity of the glass pillar C, a crooked wire proceeds, having a spring socket, F, through which a double-knobbed wire slips perpendicularly, the lower knob G of which falls just above the knob H. The glass pillar C must not be made very fast into the bottom board; but it must be fixed so that it may be easily moved round its own axis, by which means the brass ball G may be brought either nearer or farther from the ball H, without touching the part E F G. Now, when the square piece of wood L M I K (which may represent the shutter

of a window,) is fixed into the hole, so that the wire I K stands in the dotted representation L M, then the metallic communication from H to N is complete, and the instrument represents a house furnished with a proper metallic conductor; but if the square piece of wood L M I K is fixed so that the wire I K stands in the direction I K, as represented in the figure, then the metallic conductor H N from the top of the house to its bottom is interrupted at L M; in which case the house is not properly secured.

Fix the piece of wood L M I K, so that its wire may be as represented in the figure, in which case the metallic conductor H N is discontinued. Let the ball G be fixed at about half an inch perpendicular distance from the ball H; then, by turning the glass pillar C, remove the former ball from the latter; by a wire, or chain, connect the wire E F with the wire Q of the jar P; and let another wire, or chain, fastened to the hook O, touch the outside coating of the jar. Connect the wire Q with the prime conductor, and charge the jar: then, by turning the glass pillar D C, let the ball G come gradually near the ball H, and when they are arrived sufficiently near one another, you will observe that the jar explodes, and the piece of wood L M I K is pushed out of the hole to a considerable distance from the thunder-house. Now the ball G in this experiment represents an electrified cloud, which, when it is arrived sufficiently near the top of the house A, the electricity strikes it; and as this house is not secured with a proper conductor, the explosion breaks part of it, *i. e.* knocks off the piece of wood I M.

Repeat the experiment with only this variation, viz. that this piece of wood I M may be situated,

so that the wire L K may stand in the situation I M, in which case the conductor H O is not discontinued ; and you will observe, that the explosion will have no effect upon the piece of wood L M, this remaining in the hole unmoved ; which shows the usefulness of the metallic conductor.

Farther, unscrew the brass ball H from the wire H I, so that this may remain pointed ; and with only this difference in the apparatus, repeat both the above experiments ; and you will find that the piece of wood I M is in neither case moved from its place, nor any explosion heard.

To know that lightning and the electric matter are the same is a great step in natural philosophy ; but we must still remain ignorant of the causes of many of the appearances which accompany lightning, so long as our knowledge with the properties of electricity is so very imperfect. We know that the clouds are almost always electrified, sometime positively and sometimes negatively ; when these come near each other, a discharge, or flash of lightning, is generally the consequence. When a cloud is highly charged with electric matter, and there is no other cloud near that can attract it, it then strikes that part of the earth which is nearest.

Whatever may be the cause that disturbs the equilibrium of the electric matter in the atmosphere, it may easily be conceived, that when such disturbance happens in the upper and highly rarified regions of the air, the equilibrium will be restored by electric coruscations darting through the partial vacuum. This consideration accounts for the *aurora borealis*, which has commonly a darting or undulating motion between two opposite parts of the heavens. The *aurora borealis*, or

northern lights, as they are sometimes called, are most frequent in the countries nearest the poles of the earth. In Greenland and Iceland they are sometimes so strong and vivid, as to afford light sufficient to read by. A very beautiful experiment to illustrate this is what is called the *luminous conductor*, represented in Plate 20. fig. 3. A is a glass tube of about two inches in diameter, and two feet long, capped at both ends with brass, having one of the ends furnished with a stop-cock, and a screw to fit into the plate of the air-pump. This tube is exhausted of air, and when it is placed in the circuit of the electric fluid, by fixing a chain to each end which is connected with the positive and negative part of the machine, the electricity, in passing through it, exhibits a beautiful luminous appearance, very much resembling the aurora borealis.

The balls of fire, as well as the shooting stars occasionally seen in the air, seem to be masses of electricity at so great a distance that their angular velocity is not sufficient to prevent the eye from discerning their shape. It is probable, that every electric spark, or flash of lightning, consists of one or more balls of fire, though their extreme velocity presents them to the eye under the form of a line, or lines.

The appearance of *water-spouts* is generally connected with electric phenomena. Their immediate cause appears to be a vacuum that is formed in a part of the air by the convergence of winds, and their consequent whirling motion. When this happens over the sea, the water is forced up by the pressure of the surrounding atmosphere, and kept suspended until the cause that produced it ceases.

## MISCELLANEOUS EXPERIMENTS.

*The Dancing-Balls.*

Fix a pointed wire on the prime conductor, with the point outward; then take a glass tumbler (Fig. 7.) grasp it with your hands, and present its inside surface to the point of the wire on the prime conductor, while the machine is in motion: the glass in this manner will soon become charged; for its inside surface acquires the electricity from the point, and its outside loses its natural quantity of electric fluid through the hands, which serve as a coating. This done, put a few pith balls on the table, and cover them with this charged glass tumbler. The balls will immediately begin to leap up along the sides of the glass, and will continue their motion for a considerable time.

In this experiment, the pith balls are attracted and repelled by the electric fluid, superinduced upon the inside surface of the glass, which they gradually conduct to the table, or other conducting body upon which the glass is set, at the same time that the outward surface of the glass acquires the electric fluid from the contiguous air. This experiment may be made more diverting, by having a glass cylinder three inches long, and the same in width, open at both ends, with a brass plate fixed on its top; put any number of balls you please, and electrify the brass cover, and the balls will dance with a very rapid motion, which will continue as long as the operator turns the machine.

Electrical attraction and repulsion are also exhibited in a very pleasing manner, by means of a

glass tube and a feather. When the tube is excited, by being drawn through the hand or a flannel rubber, the feather, when brought near it, will be attracted, and jump to the tube; then, after taking some time to get fully saturated with electric matter (because being a bad conductor, it can receive it but very slowly,) it will suddenly jump from it, and fly towards the next conductor, upon which it may discharge the redundant electricity it has acquired. If no other body happen to be in the way, it will tend towards the ground; but if the electrified tube be held under it, it will still be repelled, and driven into the middle of the room, where it may be kept suspended, or be driven about in all directions almost as long as a person pleases, if the air be dry.

Other beautiful effects of electrical attraction and repulsion are shown at the prime conductor belonging to the machine. Suspend a plate of metal from the conductor, and underneath it, at the distance of about three or four inches, put another plate of the same size; upon the lower one of these plates lay a feather, or a small slip of light paper; and, as soon as the machine is turned, the feather or the paper will be attracted, and jump to the upper plate; from which it will be immediately repelled, and fly to discharge itself upon the lower plate, which is supported on a pedestal; after which it will be ready to be attracted and repelled again. Thus will the feather or paper fly from the one plate to the other alternately, and with inconceivable rapidity, if the electrification be pretty vigorous. When the pieces of paper are cut into the figures of men and women, they exhibit a kind of dance which is extremely amusing.

This experiment will be the more diverting if it be accompanied with that of the electrical bells, which depend upon the same principle. Four bells, *a, b, c, d*, (Fig. 4.) hang from brass rods, communicating with the prime conductor, and another bell, *e*, fixed on a brass pedestal *A*, reaching to the ground; and four small brass balls, suspended by silken threads, hang between *a, b, c, d*, and the bell *e* in the middle. The consequence of this disposition is, that the outermost bells, which hang from the prime conductor by brass chains, are electrified, and attract the brass balls which hang by silk; and the attraction being vigorous, they are made to strike the bells with some force, and make them ring. Being then loaded with electricity, they are immediately repelled from these outermost bells, and fly to unload themselves by striking upon the middle bell, which is insulated by the glass pillar *B* upon the pedestal; and from which the electric matter passes to the floor by means of the brass pedestal *A*. The brass balls, which now may be called clappers to the bells, are then ready to be attracted by the outermost bells, as at first; and thus the ringing may be continued as long as it is agreeable. The amusement will be heightened, if the electrician now and then touch the prime conductor with a brass rod, or with his finger; for then the dancing and ringing will cease, and will not be renewed till his finger or the rod be removed. If he conceal this application of his finger, or the rod, with a little art, the figures will seem to dance, and the bells to ring, at the word of command.



*The Spider seemingly animated by Electricity.*

Fig. 9 is an electric jar, having a wire C fastened on its outside, which is bent so as to have its knob E as high as the knob A of the jar. B is a spider made of cork, with a few short threads run through it, to represent its legs. This spider is fastened at the end of a silk thread proceeding from the ceiling of the room, or from any other support, so that the spider may hang midway between the two knobs A, E, when the jar is not charged. Let the place of the jar upon the table be marked; then charge the jar, by bringing its knob A in contact with the prime conductor, and replace it in its marked place. The spider will now begin to move from knob to knob, and continue this motion for a considerable time, sometimes for several hours.

The inside of the jar being charged positively, the spider is attracted by the knob A, which communicates to it a small quantity of electricity; the spider then becoming possessed of the same electricity with the knob A, is repelled by it, and runs to the knob E, where it discharges its electricity, and is then attracted by the knob A, and so on. In this manner the jar is gradually discharged, and when the discharge is nearly completed, the spider finishes its motion.

*To prove that Glass and other Electrics become Conductors when they are made very hot.*

In order to ascertain the conducting quality of hot resinous substances, oils, &c. bend a glass tube in the form of an arch, C D (Plate 20. fig. 8.),

and tie a silk string C C D to it, which serves to hold it by when it is to be set near the fire: fill the middle part of this tube with resin, sealing-wax, &c., then introduce two wires A A, through its ends, so that they may touch the resin, or penetrate a little way into it. This done, let a person hold the tube over a clear fire, so as to melt the resin within it: at the same time, by connecting one of the wires A A with the outside of a charged jar, and touching the other with the knob of the jar, endeavour to make the discharge through the resin, and you will observe, that while the resin is cold, no shocks can be transmitted through it, but it becomes a conductor as it melts: and when totally melted, the shocks will pass through it very freely.

#### *The Spiral Tube.*

Fig. 10. is an instrument composed of a glass tube, closed with two knobbed brass caps. This tube has a spiral row of small round pieces of tin-foil, stuck upon its outside surface, and lying at about one-thirteenth of an inch from each other. If this instrument be held by one of its extremities, and its other extremity be presented to the prime conductor, every spark that it receives from the prime conductor will cause small sparks to appear between all the round pieces of tin-foil stuck upon the tube, which, in the dark, affords a pleasing spectacle; the instrument appearing encompassed by a spiral line of fire.

The small round pieces of tin-foil are sometimes stuck upon a flat piece of glass (Fig. 11.), so as to represent curve lines, flowers, letters, &c. and they are illuminated after the same manner as the spiral

tube, *i. e.* by holding the extremity C or B in the hand, and presenting the other extremity to the prime conductor, when the machine is in motion. They may also be fixed in any other position, by having connecting wires.

*To show that the Electric Fluid prefers a short passage through the Air, to a long one through good Conductors.*

Bend a wire about ten feet long, at the ends of which fix a piece of glass G, to keep the knob A B at a proper distance, so that they may slide within half an inch of one another, if required; then connect the chains belonging to the sliding wires with the hook of the battery and the discharging rod, and send the charge of a battery through it. On making the explosion, a spark will be seen between A and B, which shows that the electric fluid chooses rather a short passage through the air, than a long one through the wire. The charge, however, does not pass entirely through A and B, but part of it also goes through the wire, which may be proved by putting a slender wire between A and B; for on making the discharge, with only this addition in the apparatus, the small wire will hardly be made red hot: whereas, if the large wire A D B be cut in D, so as to discontinue the circuit A D B, the small wire will be melted, and even exploded, by the same shock that before made it scarcely red-hot. In this manner the conducting power of different metals may be tried, using metallic circuits of the same length and thickness, and observing the difference of the passage through the air in each.

*The Course of the Electric Fluid in the Discharge,  
rendered visible by the Star and Pencil.*

When a jar is charged, take a discharging-rod having its ends pointed, *i. e.* the discharging-rod represented in Fig. 14., without its knobs, and keep it in such a situation, that one of its points may be at about one inch distance from the knob A, and the other point at an equal distance from the outside coating of the jar: by these means the jar will be discharged silently; and if its inside be electrified positively, you will see that the point of the discharging-rod is illuminated with a star, and the point B with a pencil; because, in this case, the electric fluid, going from the inside to the outside of the jar, enters the point C, and issues from the point B. But if the jar is electrified negatively on the inside, and consequently positive on the outside, then the pencil of rays will appear upon the point C, and the star upon the point B: for in this case, the electric fluid passes from the outside to the inside of the jar. This experiment, as well as any other in which the electric light is to be observed, must be made in the dark.

*The Leyden Vacuum.*

Fig. 15. is a small phial, coated on the outside about three inches up the side with tin-foil; at the top of the neck of this phial a brass top is cemented, having a hole with a valve; and from the cap a wire proceeds a few inches within the phial, terminating in a blunt point. When this phial is exhausted of air, a brass ball is screwed upon the cap, which is cemented into its neck, so as to defend

the valve, and prevent any air from getting into the exhausted glass. The inside of this phial requires no coating, because, as the electric fluid pervades a vacuum, it can pass freely from the wire to the surface of the exhausted glass, without the help of a non-electric coating. This phial exhibits clearly the direction of the electric fluid, both in charging and discharging; for if it be held by its bottom, and its brass knob be presented to the prime conductor positively electrified, you will see that the electric fluid causes the pencil of rays to proceed from the wire within the phial, as represented Fig. 21, and if it be discharged, a star will appear in the place of the pencil, as represented in Fig. 20. But if the phial be held by the brass cap, and its bottom be touched by the prime conductor, then the point of the wire on its side will appear illuminated with a star when charging, and with a pencil when discharging. If it be presented to a prime conductor electrified negatively, all these appearances, both in charging and discharging, will be reversed.

*To make the Electric Spark visible in Water.*

Fill a glass tube of about half an inch diameter, and six inches long, with water, and to each extremity of the tube adapt a cork to confine the water; through each cork insert a blunt wire, so that the extremities of the wire within the tube may be very near one another: lastly, connect one of these wires with the coating of a small charged phial, and touch the other wire with the knob of it; by which means the shock will pass through the wires, and cause a vivid spark to appear between their extremities within the tube. In performing this

experiment, care must be taken that the charge be very weak, otherwise the tube will burst.

In a common drinking-glass almost full of water (Fig. 16.) immerse two knobbed wires, so bent that their knobs may be within a little distance of one another in the water. If one of these wires be connected with the outside coating of a pretty large jar, and the other wire be touched with the knob of it, the explosion which must pass through the water from the knob of one of the wires to that of the other will disperse the water, and break the glass with a surprizing violence. This experiment is dangerous, if not conducted with great caution.

#### *The Powder-House.*

Fig. 17. is an ingenious contrivance, and well adapted to the purpose: the front is fitted up like the thunder-house; it is generally made seven or eight inches long, and nearly the same height to the top of the roof; the side, and that half of the roof next the eye, is omitted in the figure, that the inside may be more conveniently seen. The sides, back, and front of the house are joined to the bottom by hinges; the roof is divided into two parts, which are also fastened by hinges to the sides; the building is kept together by a ridge fixed half way on one side of the roof, so that when the building is put together, the other half of the ridge reaches over the other half of the roof, and holds it together. Within the house there is a brass tube  $1\frac{1}{2}$  inch long, and five-eighths of an inch in diameter, screwed on a pedestal of wood; into the side of this brass tube is screwed a wire, which goes through one-eighth of an inch or better; the other end, by means of a chain, has a communication to

the hook D; at the other side of the tube a piece of ivory, one inch long, is screwed, with a small hole for the wire to slide into.

To use this apparatus, fill the glass tube A with gunpowder, and ram the wire B a small way into the ivory tube; then connect the hook C with the bottom of a large jar or battery; and when the jar, &c. is charged, form a communication from the hook D to the top of the jar, &c. the discharge will then take place, and the explosion of the gunpowder will throw asunder the roof; and the sides, front, and back will then fall down.

#### *The Pyramid.*

Represented Fig. 18., is designed to show the same experiments as the thunder-house, and is used in the same manner. When the piece A is thrown out by the discharge, the upper part of the pyramid falls down; it is usually made to represent a stone steeple, and is composed of several pieces; by which means, when the discharge is made, there appears greater devastation.

#### *The Luminous Word.*

This experiment is exactly on the same principle as Fig. 10., and the word is formed by the small separations made in the tin-foil; if they were cut a little round at every division, the spark would appear more vivid as it passed along the windings.

It may be observed in making these experiments, that the longer any word is, and the oftener the tin-foil is cut, the more powerful the machine must be in order to convey the spark from one end to the other; because every time the passage is inter-

rupted by cutting, the space is increased; and in long conveyances, the space will sometimes amount to more than the machine will be able to overcome; therefore, the shorter the illuminations are, the more pleasing they will appear.

*To show how a Jar charges and discharges.*

Coat a jar, as represented Plate 21. fig. 1., by pasting small pieces of tin-foil, at a little distance from each other, round its exterior surface. As this jar is charging, small sparks will pass from one piece of tin-foil to another, in a variety of directions; the separation of the tin-foil is the means of making the passage of the fluid, from the outside of the jar to the table, visible. Discharge this jar, by bringing a pointed wire gradually near the brass ball, and the uncoated part of the glass, between the pieces of tin-foil, will be pleasantly illuminated, and make a crackling noise; but if the jar be discharged suddenly, the whole outside surface will appear illuminated. The glass must be very dry, to produce these appearances to the greatest advantage.

*To pierce a Card by Electricity.*

Take a card or quire of paper, or two cards kept asunder by the interposition of little bits of wax here and there: place either of those articles flat against the outside coating of a charged jar, and put one of the knobs of the discharging-rod over it, so that the card, or quire of paper, or the two cards, may be interposed between that knob and the coating of the jar: then by bringing the other knob of the discharging-rod near the wire of the



jar, make the discharge; and the electric matter, rushing through the circuit from the positive to the negative side of the jar, will pierce a hole, and frequently more than one hole, quite through the card, or cards, or quire of paper, &c. and each hole will be found to have a bur raised on each side, unless the card be pressed too hard against the side of the jar.

If the nose be immediately applied to the perforation, a smell somewhat like that of phosphorus will be perceived. If, instead of paper, a very thin plate of glass, or resin, or sealing-wax, be interposed between the discharging-rod and the outside coating of the jar, on making the discharge this will be broken to pieces.

#### *To set Cotton on Fire.*

Take a wire of the size of a common knitting-needle, or larger, and, by means of any flexible wire or chain, let one end of it communicate with the outside coating of a jar, that contains at least ten square inches of coated surface. Round the other end of the first-mentioned wire, some cotton must be twisted, so as to form a head round it, and thus conceal the end of the wire. Roll this head of cotton in powder of lycopodium, or in powder of resin; this done, charge the jar, and bring the cotton head rather quickly towards its knob; by which means the discharge will be made to pass through the cotton, which will be instantly set on fire.

#### *The Electrical Pistol.*

This curious apparatus is represented Plate 21. fig. 2. It is made of sheet-brass or tin. To the

mouth A, a cork is fitted, and a perforated piece of brass *e* screws on the bottom of the pistol, having a glass tube with a wire cemented into it, bent over the glass tube, so as to reach within one-eighth of an inch of the brass. When this pistol is charged with inflammable air mixed with common air, by applying a small charged Leyden phial to the knob, it will explode with a report like gunpowder, and drive out the cork to a considerable distance. To load it with inflammable air, nothing more is necessary than to hold it inverted, with its mouth open, over a bottle containing that air: the inflammable air will ascend into the pistol, while the common air descends into the bottle. The method of making the inflammable air will be found under Chemistry, in vol. ii.

#### *The Electrified Capillary Syphon.*

Let a small bucket of metal, full of water, be suspended from the prime conductor, and put in it a glass syphon (Fig. 3.), of so narrow extremity as that the water will just drop from it. If, in this disposition of the apparatus, the winch of the machine be turned, the water which, when not electrified, only dropped from the extremity of the syphon, will now run in a full stream, which will even be subdivided into other smaller streams; and if the experiment be made in the dark, it will be beautifully illuminated like a fountain with streams of fire, which may be made to stop apparently by the word of command, by touching the prime conductor.

*To fire Gunpowder by Electricity.*

In order to fire gunpowder by the Leyden phial, make a small cartridge of paper, and fill it with gunpowder, or else fill the tube of a quill with it, and insert the pointed extremities of two wires in it, so that their extremities within the powder may be about one-fifth part of an inch from each other. This done, send the charge of a Leyden phial through those wires, and the gunpowder will be fired. If the powder be mixed with steel filings, the experiment will succeed even with a small shock.

If the gunpowder be placed loosely upon any stand, and the interruption of the wire circuit be made in it, on making the discharge of the jar, the spark which takes place at the interruption will scatter the gunpowder without firing it. But the loose gunpowder may be fired, if the shock be transmitted through less perfect conductors; in which case the discharge being less sudden, or rather proceeding in a stream, the powder will be fired. The best method of performing this experiment is that recommended by Cavallo, which is as follows:

F (Plate 21. fig. 4.), represents the gunpowder placed upon the same table upon which the jar A is situated. B is a glass tube about one foot long, and a quarter of an inch in diameter, full of water, and having two corks at its extremities. Into these two corks two wires are thrust, the inner extremities of which just touch the water, viz. the short wire at F and the long wire C, which makes

the communication between the water of the tube and the knob of the jar. On making the discharge, which must pass through the small quantity of water in B, and through the table F, both imperfect conductors, the electric fluid comes out at F, in the form of a dense stream, which generally fires the gunpowder.

*Practical Rules concerning the Use of the Electrical Apparatus, and the performing of Experiments.*

It often happens, that young electricians are at a loss to assign the reason why some experiments do not succeed with them. They are in possession of good instruments; but from some circumstance or other not being attended to they are quite useless in their hands. This, indeed, can be remedied only by practice; and it is by long use that the electrician, as well as the practitioner in any other art or science, becomes so good an operator, as to use his instruments to the best advantage. A few rules are, however, useful to guide him in his operations; and although these alone are insufficient to make a person a complete practical electrician, yet, when accompanied with the actual management of the apparatus, they facilitate the use of it, and render the performance of the experiments more accurate and expeditious.

The first thing that the young electrician should attend to is the preservation and care of his instruments. The electrical machine, the coated jars, and, in short, every part of the apparatus, should be kept clean, and as free as possible from dust and moisture.

When the weather is clear, and the air dry, especially in clear and frosty weather, the electrical machine will work well; but when the weather is very hot, the machine is not so powerful; nor in damp weather, except it be brought into a warm room, and the cylinder, the stands, the jars, &c. be made thoroughly dry.

Before the machine is used, the cylinder should be first wiped very clean with a soft linen cloth that is dry, clean, and warm; and afterwards with a clean hot flannel, or an old silk handkerchief; this done, apply a little amalgam, and turn the winch, and it will soon be perceived that the electric fluid will come like a wind from the cylinder to the knuckle; and, if the motion be continued, sparks and cracklings will soon follow. This indicates that the machine is in good order; and the electrician may proceed to perform his experiments. But if, when the winch is turned for some time, no wind is felt upon the knuckle, then the fault is, very likely, in the rubber; and to remedy that, observe the following directions: by unscrewing the screws on the back of the rubber, remove it from its glass pillar, and keep it near the fire a little, so that its silk part may be dried: take now a piece of dry mutton suet, or a little tallow from the candle, and just pass it over the leather of the rubber, and then the machine will be fit for use.

Sometimes the machine will not work well, because the rubber is not sufficiently supplied with electric fluid, which happens when the table upon which the machine stands, and to which the chain of the rubber is connected, is very dry, and consequently in a bad conducting state. Even the floor, and the walls of the room, are, in very dry weather, bad conductors, and they cannot supply the rubber

sufficiently. In this case the best expedient is to connect the chain of the rubber, by means of a long wire, with some moist ground, or with the iron-work of a water-pump, by which means the rubber will be supplied with as much electric fluid as is required.

When a sufficient quantity of amalgam has been accumulated upon the leather of the rubber, and the machine does not work very well, then, instead of putting more amalgam, it will be sufficient to take the rubber off, and to scrape a little off that which is already upon the leather.

It will be often observed, that the globe or cylinder, after being used some time, contracts black spots, occasioned by the amalgam, or some foulness of the rubber, which grow continually larger, and greatly obstruct its electric power. These spots must be carefully taken off, and the cylinder must be frequently wiped, in order to prevent its contracting them.

In charging electric jars in general, it must be observed, that every machine will not charge them equally high. That machine, whose electric power is the strongest, will always charge the jars highest. If the coated jars, before they are used, be made a little warm, they will receive and hold the charge the better.

If several jars be connected together, among which there is one that is apt to discharge itself very soon, then the other jars will also be soon discharged with that; although they may be capable of holding a very great charge by themselves. When electric jars are to be discharged, the electrician must be cautious, lest, by some circumstance not adverted to, the shock should pass through any part of his body; for an unexpected shock, though

not very strong, may occasion several disagreeable accidents. In making the discharge, care must be taken that the discharging-rod be not placed on the thinnest part of the glass; for that may cause the bursting of the jar.

When a large battery is discharged, jars will be often found broken in it, which burst at the time of the discharge. To avoid this inconvenience, never discharge the battery through a good conductor, except the circuit be at least five feet long. Mr. Nairne says, that ever since he made use of this precaution, he discharged a very large battery near 100 times, without ever breaking a single jar; whereas, before he was continually breaking them. But here it must be considered, that the length of the circuit weakens the force of the shock proportionably; the highest degree of which is in many experiments required.

It is advisable, when a jar, and especially a battery, has been discharged, not to touch its wires with the hand before the discharging-rod be applied to its sides a second, and even a third time; as there generally remains a residuum of the charge: this residuum is occasioned by the electricity, which, when the jar is charging, spreads itself over the uncoated part of the glass near the coating, which will not be discharged at first, but gradually returns to the coating after the first discharge, which is sometimes very considerable.

When any experiment is to be performed, which requires but a small part of the apparatus, the remaining part of it should be placed at a distance from the machine, the prime conductor, and even from the table, if that is not very large. Candles, particularly, should be placed at a considerable distance from the prime conductor; for the attraction

of their flames carries off much of the electric fluid.

Lastly, the young electrician is cautioned not to depend on first appearances in electricity. A new phenomenon may justly excite his curiosity. It is laudable to remark it, and to pursue the hint; but at the same time, even the doubtful assertion of a new fact should never be made till after a number of similar and concurring experiments. Electricity is a science that often deceives the senses; and the most experienced frequently finds himself mistaken in things which perhaps he may have considered before as the most certain.

In many electrical experiments, it is very convenient to have a method of determining, whether a small degree of electricity be positive or negative: and in using large batteries, it is a matter of consequence to know how the charge advances, and of what strength it is. Mr. Canton's balls are extremely useful for both these purposes. They are made of the pith of elder, turned perfectly globular, and suspended from the conductor by fine threads.

To understand the use of them, suppose a jar or battery stands upon the table; to know whether the inside be charged positively or negatively; present the balls, and they are immediately attracted by the wire, and diverge from one another. This is common to both electricities; and the greater the distance to which the balls separate, and the farther they repel one another, the higher is the charge. To determine of what kind it is, rub a small piece of glass against your hand or coat, which will excite it positively, and then present it to the balls in their diverging state. If it make the balls converge, and consequently avoid the



glass, it shows that they are electrified positively, as well as the glass. On the contrary, if it increase their divergency, and attract them, it shows their electricity to be of a kind opposite to that of the glass; that is, negative. And it must be remembered, that the electricity of the balls which do not touch, or receive any electricity from the wires of the jar or battery, is always contrary to that with which they are charged; for all bodies placed within the influence of electrified bodies are affected with the contrary electricity.

In order to ascertain the kind of an exceeding small degree of electricity, it will be convenient to have a very light body; as a piece of downy feather hanging by a silken thread. This light body, when it is once electrified, either positively or negatively, will retain its virtue a long time, with very little loss. If then, any body, the electricity of which is unknown, be brought to it, the feather will be repelled by it, if it be of the same kind with its own, and attracted if it be the contrary to it. The silk by which it is suspended should be a single thread, as it comes from the worm; or at least a very few of those threads; and the whole should be as light as possible.

As glass is apt to attract and condense the moisture from the air, (in which case it conducts the electricity over its surface,) it is best to cover with *sealing-wax*, or to *varnish* over, the glass pillars of the machine, as also all the glass stands, and other articles used for insulating; for when varnished, and especially when covered with sealing-wax in the dry way, they attract the moisture, either not at all, or in a much less degree; and, of course, they insulate much better.

To cover glass with sealing-wax in the dry way, glass should be warmed gradually near the fire, and when sufficiently warm, a stick of sealing-wax must be gently rubbed over its surface; by this means the sealing-wax is melted, and adheres to the glass. As this is a troublesome operation, and there is some risk of breaking the glass, the sealing-wax is sometimes dissolved in spirit of wine, and laid on with a hair pencil. For this purpose the wax must be broken into small bits, and suffered to remain in the spirit for a day or two, shaking it now and then. This solution must be laid upon the glass when dry and clean, by means of a hair-pencil, and when the first coat of it is quite dry, then a second, a third, and even a fourth coat, should be applied. The best varnish for this purpose is the amber-varnish, which, indeed, answers as well as the sealing-wax, in the dry way, but it must be made with great care and attention. For the process of making it, see vol. ii. article Varnishes.

To make the *amalgam* for laying on the rubber, mix two parts of quicksilver with one of tin-foil, adding a small quantity of powdered chalk; and rub them together in a mortar until it becomes a mass like paste.

A better amalgam is the following: put a quantity of quicksilver into a crucible, and heat it above the boiling point of water. Also melt a fourth part of zinc in another crucible. Pour the heated quicksilver into a wooden box, and add the melted zinc to it. Then shut the box, and shake it for a minute or two. You must suffer it to remain till it is almost cold, and you will find that the two metals have united perfectly, forming an amalgam.

You may mix a quantity of hog's-lard with it by rubbing in a mortar, adding to it a small portion of whitening, and about a fifth of the above-mentioned amalgam of tin.

#### OF ANIMAL ELECTRICITY.

By animal electricity, we mean the electricity that is produced by the voluntary action of the organs of living animals.

Fishes are the only animals yet known to possess the wonderful property of being able at pleasure to give a shock analogous to that produced by artificial electricity. Of these we are acquainted with three species, viz. the *torpedo*, the *gymnotus electricus*, and the *silurus electricus*.

The torpedo is a flat fish, very seldom 20 inches long, weighing not above a few pounds when full grown, and is common in various parts of the sea-coast of Europe. The electric organs of this animal are two in number, and are placed on each side of the gills. Each organ consists of perpendicular columns, reaching from the under to the upper surface of the body, and varying in length according to the thickness of the fish in different parts. The number of these columns varies in different torpedos, and also in different ages of the animal.

If the torpedo, whilst standing in water, or out of it, but not insulated, be touched with one hand, it generally communicates a trembling motion, or slight shock to the hand; but the sensation is felt in the fingers of that hand only. If the torpedo be touched with both hands at the same time, one being applied to its under, and the other to its upper surface, a shock in that case will be received,

which is exactly like that occasioned by the Leyden phial. This power of the torpedo is conducted by the same substances which conduct artificial electricity, and is intercepted by the same bodies which are non-conductors of electricity. The circuit may be formed by several persons joining hands, and the shock will be felt by them at the same time; but no attraction or repulsion was ever observed to be produced by the torpedo.

These shocks depend upon the will of the animal, each effort being accompanied with a depression of the eyes, and motion of the organs.

The *gymnotus electricus* has been frequently called the *electrical eel*, on account of its bearing some resemblance to the common eel. It is found frequently in the great rivers of South America. Its usual length is about three feet; but some of them have been said to be so large, as to strike a man dead with their electric shock. A few of these animals, about three feet long, were brought alive to England about thirty years ago, and a great many experiments were made with them. They possess all the properties of the torpedo, but in a superior degree. The spark was visible in a dark room.

The *silurus electricus* is found in Africa, but we have a very imperfect account of its properties. Its length seldom exceeds twenty inches.

These animals seem to use the electrical property as a means of self-defence.

The nature of the electricity thus excited by animals, appears to be analogous to galvanic electricity, which will be treated of afterwards.

## MEDICAL ELECTRICITY.

Electricity has often been used for medical purposes; but with degrees of success extremely various.

In administering it, the following directions will be found useful.

The smallest force of electricity should be used, which may be sufficient to remove or alleviate any disorder. One of the chief difficulties consists in distinguishing the proper strength of the electric power that is required. The sex and condition of the patient must be duly considered. The surest rule is, to begin with the most gentle treatment; as least such as, considering the constitution of the patient, may be thought rather weak than strong. When this has been found ineffectual for a few days, the application not causing any material alteration, then the operator may gradually increase the force of electricity until he finds the proper degree of it.

In judging of cases proper to be electrified, experience shows, that, in general, all kinds of obstructions, whether of motion, of circulation, or of secretion, are very often removed or alleviated by electricity. The same may also be said of nervous disorders; both which include a great variety of diseases. The application of electricity has also been found very beneficial in diseases of a long standing. It has likewise been found a powerful remedy in muscular contractions. But when any limb is deprived of motion, it must be observed, that the deprivation has not always originated in a contraction of the muscles; but that it is often occasioned by relaxation; thus, for instance,

if the hand be bent inwardly, and the patient have no power of straightening it, the cause of it may be a weakness of the outward muscles, as well as a contraction of the inward ones. In such cases, it is often difficult, even for good anatomists, to discover the real cause; but the surest method is, to electrify not only those muscles which are supposed to be contracted, but also their antagonists; for to electrify a sound muscle is by no means hurtful.

Rheumatic disorders of long standing, are relieved, and frequently cured, by only drawing the electric fluid with a point from the part, or by drawing sparks from the conductor; the operation should be continued for about four or five minutes, repeating it once or twice every day. When strong shocks are administered, their greatest number should not exceed twelve or fourteen, except when they are to be given to the whole body in different directions.

The instruments, which, besides the electrical machine and its prime conductor, are necessary for the administration of medical electricity, may be reduced to three, viz. an electric jar, with Lane's electrometer; an insulated chair, or an insulated stool, upon which a common chair may be occasionally set; and the directors.

Fig. 5. represents the electric jar, with Lane's electrometer, and the manner in which the shocks are sent through any part of the body. The surface of the jar, which is coated with tin-foil, should be about four inches in diameter, and six inches high, which is equal to about seventy-three square inches. The brass wire, which passes through the covering of the jar, and touches the inside coating, has a brass ball F, to which the electrometer F D E is fastened; and proceeding a

little farther up, terminates in another brass ball B, which should be so high as to touch the prime conductor A, which is supposed to stand before the electrical machine. The electrometer consists in a glass rod, F D, cemented to two brass caps, F and D; from the latter of which a strong perpendicular brass wire proceeds, the extremity of which comes as high as the centre of the ball B, and is furnished with an horizontal spring socket, through which the wire C E, having the brass ball C at one end, and the open ring E at the other, may be slid backwards and forwards, so as to set the brass ball C at any required distance from the ball B. This distance, at most, need not be greater than half an inch; hence the electrometer may be very small. Sometimes small divisions are marked upon the wire C E, which serve to set the balls B and C at a given distance from one another with more readiness and precision. Now, suppose that the jar is set contiguous to the prime conductor, that is, with the ball B touching the conductor; that the ball C be set at one-tenth of an inch distant from the ball B, and that, by means of a chain, a conducting communication be formed from E to the outside coating of the jar, by a chain *x*: in this case, if the electrical machine be put in motion, the jar will be charged; and when the charge is so high as that the electric fluid accumulated within the jar, can leap from the ball B to C, which we have supposed to be one-tenth of an inch asunder, the discharge will take place, a spark appear between the said balls, and the shock pass through the chain *x*: for the part F D of the electrometer, being of glass generally covered with sealing-wax, is impervious to electricity, consequently the electric fluid has no other way through which it can

pass from the inside to the outside of the glass jar. When the shocks are to be given with this apparatus to any particular part of the body, for instance, to the arm, then instead of the chain *x*, which must now be taken away, two slender and pliable wires, *E L*, *I L*, are to be fastened, one to the open ring *E* of the electrometer, and to the brass hook *I* of the stand *H I*, which communicates with the outside coating of the jar. If the jar has not the stand *H I*, the extremity *I* of the wire *I L* may be simply rested under, or may be tied round it. In short, it must be put in contact with the outside coating of the jar, in any convenient manner. The other extremities of the wires must be fastened to the brass wires *L*, and *L* of the directors *K L*, *K L*. Each of those instruments, justly called directors, consists of a knobbed brass wire *L*, which, by means of a brass cap, is cemented to the glass handle *K*. The operator, holding them by the extremity of the glass handle, brings their balls into contact with the extremities of that part of the body of the patient through which he desires to send the shock. The management and convenience of this apparatus are easily comprehended by inspecting the figure; for when the machine is in motion, and the apparatus, &c. is situated as in the figure, the discharge of the jar must be evidently made through that part of the patient's arm which lies between the knobs of the directors; and the operator, whilst an assistant keeps the machine in motion, has nothing more to do but to hold the knobs of the directors to the extremities of the arm, or to any other part of the body that is required to be thus electrified; always taking care that the two wires *E L*, *I L*, do not touch each other, because, in that case, the shock will



not pass through that part of the body which is required to be electrified. Thus, any number of shocks, precisely of the same strength, may be given, without altering any part of the apparatus, or having any farther trouble: and when the strength of the shocks is required to be diminished or increased, it is only necessary to diminish or augment the distance between the balls B C, which is done by slipping the wire C E forwards or backwards through the spring socket that holds it.

It is almost needless to mention, that when shocks are administered, it is immaterial whether the patient stands upon the ground, upon the insulating stool, or in any other situation whatever. Neither is it always necessary to remove the clothes from the part that is to be electrified, in order to let the knobs of the directors touch the skin; for except the coverings be too many and too thick, (in which case, part of them at least should be removed,) the shocks will go through them very easily, especially if the knobs of the directors be pressed a little upon the part.

Plate 21. fig. 6. represents a useful instrument to cure the tooth-ach. A is a flat square piece of box-wood, about an inch broad, and a quarter of an inch thick; two longitudinal holes are made quite through it, near its opposite edges; through which the brass wires, *a*, *b*, *c*, and *e f*, are put whilst they are straight; then fixed with sealing-wax, and bent as in the figure, so as to receive the tooth and gum between their points, *c* and *f*, which must not be too sharp, for fear of hurting the gum. When it is used, two chains, *g* and *h*, must be hooked to the other ends of these wires, and holding it on the gum, with the tooth between

the ends of *c* and *f* of the wires *a b c* and *d e f*, hook the chains *g* and *h* on the other ends of these wires: put the other end of the chain *g* round the bottom of a jar, and cause an assistant to hold the chain *h*, hanging down from his hand, the chains not touching one another, and both of them clear from the table; then having charged the jar, desire the assistant to strike the prime conductor with the loose end of the chain *h*; this will discharge the jar, and give a person a shock which will be felt only in the tooth and gum that is taken in between the wires at *c* and *f*.

## GALVANISM.

---

**G**ALVANISM is considered as electricity developed by chemical action alone, without the aid of friction.

The first observation of its effects was owing to an accident. The wife of Galvani in preparing as a restorative a soup made of frogs, happened to notice that the muscles of one of the frogs which had been skinned, were thrown into violent convulsions, when touched with a scalpel in the neighbourhood of an electrical machine. Her husband repeated the experiment, and found that the crural nerve of a frog, or the nerves of any animal, was a more delicate test of the presence of electricity than of any other known substance, much more so than Bennet's electrometer.

He afterwards discovered that when the muscles of a frog were in contact with one metal, and the nerve in contact with a different metal, very violent contractions were produced when the two metals were made to touch each other, or were connected by any substance which was a conductor of electricity. He also observed that some combinations of metals were more powerful than others, and that zinc and silver had the most effect.

Galvani supposed that some power of exciting electricity existed in the muscles of the animal:

but Volta afterwards explained this effect, by imagining that the moisture of the animal excited the electrical agency of the metals, and that the organs of animals served only as a delicate test of the presence of electricity.

It has been found that the mere contact of two metals is sufficient to produce electricity without any intervening fluid ; when separated, that which has the strongest attraction for oxygen exhibits signs of positive, the other of negative electricity.

But when any fluid that acts chemically upon the metals is also used, the developement of electricity is much more considerable. The fluids commonly used are water, and acids very much diluted with water : and the metals act best when one is easily, and the other with difficulty, oxidable.

The original source of the electricity is not yet perfectly understood : there are two opinions respecting it ; one supposes that it depends merely upon the contact of the metals, and that the chemical action is really the consequence of the evolution of electricity : the other opinion is, that the chemical action is the first in order of time, and that it occasions the developement of the electric fluid.

The electricity excited by the contact of two metals is perceived by the following easy experiment. Place a piece of zinc upon the tongue, and a piece of silver under the tongue, and let both pieces project a little beyond the tip : then bring the metals into contact, when a peculiar sensation will be perceived resembling that of common electricity applied to the tongue. This is really owing to the developement of a small quantity of electricity, which is called Galvanic electricity.

This effect is greatly increased by employing many alternations of substances proper for the purpose. Thus if in a glass tube there are regularly arranged alternating plates of silver, zinc, and thin paper, having one end terminating with a zinc plate, and the other with a silver plate, and the opposite ends of the tube be laid upon electrometers; it will be perceived that one electrometer will be affected by negative, and the other by positive electricity.

Plate 26. fig. 6. represents this arrangement.

But if a solution of salt, or a diluted acid be employed as one of the alternating substances, the indications of electricity will be much more evident. It was in this way that Volta constructed that which has since been denominated the Voltaic pile or battery.

Take a number of plates of copper, or, what is better, of silver; and an equal number of tin plates, or, what is still better, of zinc; and the same number of pieces of card, leather, or woollen cloth, the last of which seems to answer the best. Let these last be well soaked in common water, or rather, in a solution of common salt, sal ammoniac, nitre, or nitrous acid. The silver or copper may be pieces of money, and the zinc pieces may be cast of the same size. A pile is to be formed of these substances in the following manner: a piece of zinc, a piece of silver, and a piece of wet cloth, or card; then another piece of zinc, a piece of silver, and a piece of wet cloth; and so on in the same order, till the number required has been placed. But, as the pieces, when unsupported, are apt to fall down when their number is considerable, it is best to support them by means of three rods of glass, stuck into a piece of wood, and touching the metallic

pieces at three equally distant points, as represented in Plate 21. fig. 7. Down these rods may slide a small circular piece of wood, having three holes in it, and which will serve to keep the top of the pile tight, and the different pieces in close contact. The moistened pieces should likewise be somewhat less than the pieces of metal, and though they should be well moistened, they should be gently squeezed before they are applied, that the superfluous moisture may not run down the pile, or insinuate itself between the pieces of metal.

The instrument, constructed in this manner, will afford a constant current of the electric fluid, through any conductor communicating between the uppermost and lowest plate; and, if one hand be applied to the lowest plate, and the other to the upper, a shock is felt, which is repeated as often as the contact is renewed. An objection to this construction of the pile, or battery, is the trouble of placing the pieces in the proper order, and also that of cleaning the pieces of zinc, which are rapidly oxydated. The best method of doing this is by a file, or by putting them into diluted muriatic acid, which dissolves the oxyd.

The battery, Fig. 8., consists of a row of wine-glasses, or cups, containing salt and water, or sulphuric acid and water. Into each of these is plunged a plate of zinc, and another of silver or copper. These plates are made to communicate with each other by means of a thin wire, fastened so that the silver of the first glass is connected with the zinc of the second, the silver of the second with the zinc of the third, and so on progressively through the whole chain of glasses. When one hand is dipped into the first glass, and another in the last, the shock is perceived.

This machine will continue in action a very long time, and when the pieces of zinc are oxydated they may be easily taken out and cleaned.

Volta chiefly confined his experiments with galvanism to its effects on animals. He considered it to be the same as electricity, because it gave a similar shock ; and because, having applied two rods, one formed of silver and the other of tin, to the two disks of Nicholson's doubler, he found that the disk in contact with the silver rod indicated negative electricity, and that in contact with the tin showed positive electricity. These experiments were repeated in this country by Nicholson and Carlisle ; and, in the course of them a part of the circuit of the pile happening to be formed through water, they noticed the decomposition of that fluid, as shown by the separation of the two gases of which it consists.

The apparatus for showing this is extremely simple. Fill a small glass tube with distilled water, and fitting a cork to each extremity, as in Fig. 14., make a piece of brass or copper wire pass through each of the corks into the water. Connect then the wire A with one of the extremities of the battery, while the wire B communicates with the other extremity. You will then find, that minute bubbles of gas proceed in a constant stream from the end of the wire, which passes from the negative end of the battery, and ascending to the upper part of the tube accumulate by degrees. This gas, if examined, will be found to be hydrogen, and may be inflamed by the approach of an ignited body on pulling out the cork. At the same time the other wire deposits a stream of oxyde in the form of a cloud, which gradually accumulates on the sides and bottom of the tube. If you interrupt the circuit, the streams

of gas and oxyd disappear, but are renewed again upon restoring the communication.

In this experiment it would appear that the hydrogen is separated from the water, and is converted into a gaseous state by the wire connected with the negative extremity of the battery; whilst the oxygen unites with, and oxydates the wire connected with the positive end of the battery. If you connect the positive end of the battery with the lower wire of the tube, and the negative with the upper, then the hydrogen proceeds from the upper wire, and the lower wire is oxydated.

If two wires of gold or platina be used, they are not oxydable; then streams of gas issue from each; the water is diminished; and the collected gas is found to be a mixture of hydrogen and oxygen, and explodes violently on the approach of an ignited body, or by the electric or the galvanic shock.

To obtain these gases separately, let the two ends of the gold wires be immersed in a vessel of water (Fig. 15.), and be about one inch apart. Then hang over them two wine-glasses, inverted, and full of water. The gases will ascend into the separate vessels.

It is well known that hydrogen gas, in its nascent state, reduces the oxyds of metals. Accordingly, when the tube (Fig. 14.) is filled with a solution of acetite of lead in distilled water, and a communication is made with the battery as above described, no gas is perceived to issue from the wire which proceeds from the negative end of the battery; but in a few minutes, beautiful metallic needles are perceived on the extremity of this wire; these soon increase, and assume a dendritical appearance or the form of fern. The lead thus separated is in its perfect metallic state, and very brilliant.



The preceding facts can hardly leave any doubt with respect to the identity of the galvanic power, and the electricity which is produced by means of a common electrical machine, or that which is brought down from the clouds. It reconciles to the same principle, the animal electricity; viz. the power of the torpedo, *gymnotus electricus*, &c. since all the phenomena of the animal electricity agree with those of the galvanic battery. The electric organ of any of the above-mentioned fishes seems to be constructed exactly like a galvanic battery; for it consists of little laminæ, or pellicles, arranged in columns, and separated by moisture.

The resemblance between the effects of galvanic and common electricity in decomposing water where the latter seemed to fail, was confirmed by an experiment of Dr. Wollaston, in which, with a very simple apparatus, he decomposed water by a current of electricity from the prime conductor of an electrical machine.

He likewise remarked another strong point of analogy between the electricity of galvanism, and that of the common electrical machine, viz. that they both seem to depend upon oxydation. In fact, a common electrical machine will act more or less powerfully, according as the amalgam which is applied to its rubber consists of metals that are more or less oxydable.

A great improvement in the construction of the Voltaic pile was made by Mr. Cruickshank, which increased its power so as to render it an important chemical agent.

Plate 21. fig. 9. represents this battery. It consists of a trough of baked wood, about three inches deep, and about as broad. In the sides of

this vessel are grooves opposite to each other, and about a quarter of an inch apart. Into each pair of these opposite grooves is put a plate of zinc and silver, or zinc and copper soldered together. These plates are well fixed in the grooves, in the proper order of copper and zinc, as in the pile, by a cement made of five parts of resin, four of bees-wax, and two parts of powdered red ochre. This cement must be run in very carefully, so as completely to prevent any communication between the different cells, which would entirely prevent the action of the machine. The cells are then filled with water containing a little acid, common salt, or muriate of ammoniac.

When a communication is made between the first and last cell, by means of the hands, a strong shock is felt.

A still better construction of the galvanic battery is as follows. A (Plate 26. fig. 7.) is a trough made of earthenware with partitions, into which the diluted acid is put: and alternate plates of zinc and copper, B, are fixed to a bar of wood C, and immersed in the trough, so that a plate of zinc and another of copper shall come into each partition, when the apparatus is used: at other times they are kept out of the trough, and hung upon the uprights, D, E. Thus, the plates are not liable to be so much corroded, as in the former construction, and the apparatus is more powerful as both the surfaces of the plates are acted upon. It is in this way that the magnificent galvanic apparatus in the Royal Institution is formed, and which was made under the direction of Sir H. Davy. It consists of 2000 double plates of zinc and copper 6 inches square, each trough containing 20 plates. It was frequently exhibited during his lectures.

These improvements in the apparatus rendering experiments more easy, gave rise to numerous discoveries. It would exceed the limits of this work to detail the history of this science, which is of such modern date. The decomposition of the alcalies and alkaline earths by Sir H. Davy is a striking proof of the importance of galvanism as a chemical agent.

The action of all these batteries is greatest when they are first completed, or filled with the fluid; and it lessens in proportion as the metal is oxydated, or the fluid loses its power. Hence, after a certain time, not only the fluid must be changed, but the metallic pieces must be cleaned by removing the oxydated surface.

When a galvanic battery consists of twenty repetitions of simple combinations, if you touch with one hand one extremity of the battery, and apply your other hand to the other extremity, you will feel a very slight shock, like that which is communicated by a Leyden phial weakly charged; and it will be hardly felt beyond the fingers, or at most the wrists. This shock is felt as often as you renew the contact. If you continue your hands in contact with the extremities, you will perceive a slight but continued irritation; and when the hand, or the other part of the body which touches the other extremity of the battery, is excoriated or wounded, this sensation is disagreeable, and sometimes very painful.

The intensity of the charge is, however, so low, that it cannot make its way through the dry skin of the hand, which is but an imperfect conductor: the fingers should, therefore, be well moistened with water. It will be better to immerse a wire that proceeds from one extremity of the battery in

a basin of water, wherein you may plunge one of your hands : then grasping with your other hand well moistened a large piece of metal, for instance a large silver spoon, touch the other end of the battery with it, and the shock will be felt more distinctly.

Several persons may receive the shock together, by joining hands in the same manner as in receiving the shock from a Leyden phial. For this purpose, the hands must be well moistened with water. But the strength of the shock is much diminished by passing through so long a circuit, the last person feeling it much less violently than the first. In general, its effect is lessened by passing through imperfect conductors.

The shock from a battery consisting of 50 or 60 pairs of zinc and silver, or zinc and copper, may be felt as far as the elbows ; and the combined force of five or six such batteries will give a shock that few men would be willing to receive. The prepared limbs of a frog, or other animal, are violently convulsed, but soon exhausted of their irritability by the action of this battery.

The spark from a galvanic battery acts with astonishing activity upon inflammable bodies when sent through them. It fires gunpowder, ether, spirit of wine, cotton, hydrogen gas, phosphorus, &c. ; it renders red hot, fuses, and consumes, metallic wires, and metallic leaves, as tin-foil, gold, silver, and brass-leaf. The method of making these experiments is as follows : having filled the cells of the battery (Fig. 9.) with water containing a little nitrous acid (about one-tenth of acid will form a very active fluid), wipe carefully the edges of the plates with a towel, to prevent any communication between the cells. Having fastened bits

of copper to the ends of two pieces of wire, as Fig. 10, (annealed copper wire is the best) insert them into the fluid in each of the extreme cells, as in Fig. 9. Upon the other ends of the wires, slip on a bit of small glass tube to lay hold of the wires by. After a few minutes the acid will act upon the plates; and if the points of the wires be brought near to each other by moving them by the glass tubes, a spark will be perceived between them. Some of the inflammable substance intended to be acted upon may be laid upon a plate of glass, or put between the points of the wires. In this manner the combustion of gold and silver leaf, &c. may be shown, forming some of the most beautiful experiments. Copper or brass leaf, commonly called Dutch gold, burns with a beautiful green light; silver, with pale blue light; gold, with yellow light; and all, with a crackling something analogous to the noise heard in the burning of paper rubbed over with wet gunpowder.

When very great power is wanted, several of these batteries may be united, by placing them together, as in Plate 21. fig. 11. Pieces of copper are cut into the form shown by Fig. 12., and bent as in Fig. 13.: the bent ends of these pieces being inserted into the adjoining cells, at the extremities of each battery, a communication is formed from the end A of the first battery, to the end B of the last battery. If wires be now placed in these ends, in the same manner as in the battery, Fig. 9., the collected force of the whole will be exhibited at the points of the wires.

It is usual to make these batteries with 50 pairs of metallic plates in each; so that four batteries contain 200 pairs of plates, which are sufficient to

produce all the effects above-mentioned in the most satisfactory manner. Two of these batteries will, if properly prepared, exhibit most of the usual experiments.

The galvanic shock is similar to that from a common electrical battery weakly charged, and not like a small Leyden phial fully charged. The difference appears to consist in this, that the latter contains a small quantity of the electric fluid much condensed.

If a wire, proceeding from one extremity of a pretty strong galvanic battery, be made to communicate with the inside coating of a common large jar, or electrical battery, and a wire which proceeds from the other extremity be made to communicate with the outside coating, the latter will become *weakly*, but almost *instantaneously*, charged, in the same manner as if it had been charged by a few turns of a common electrical machine; and with that charge you may produce the same effects as by equal quantity of common electricity.

The Voltaic battery has a great superiority over the common electrical machine, in the *quantity* of electricity excited; but is very inferior with respect to the *intensity* of the charge, or its power of forcing through any stratum of air, or other imperfect conductor. The sensation called shock, depends chiefly upon the intensity: hence, although a large Voltaic battery will produce a great quantity of the electric fluid, yet the shock is comparatively small. In the Voltaic battery, the electricity cannot even force its way through the water that separates the plates, but common electricity will pass through a large space of water: it has even been sent across the Thames.

But this great quantity of electricity produced by galvanism renders it the most powerful of all chemical agents. All inflammable substances are attracted by the negative pole, and the supporters of combustion or acidifying principles are attracted by the positive pole. Hence some consider the natural state of the electricity of inflammable substances as positive, since it is attracted by the negative; and that of the supporters of combustion as negative, since they are attracted by positive electricity.

When this apparatus was employed, if two pieces of charcoal were attached to the opposite wires and brought together, a bright spark appeared, and ignition of the charcoal: if then they were slowly separated by means of the apparatus, (Plate 25. fig. 9.,) an arch of intense fire, four inches in length, was produced, in which all metals burned with great facility, and many very refractory substances were fused.

The Voltaic pile communicates the greatest degree of divergence to the electrometer when pure water alone is used; but diluted acids which act chemically on the plates, occasion it to produce most ignition, and the greatest shocks.

Its power of giving shocks, or the intensity of the electricity, increases according to the number of alternations; but the quantity of electricity is increased by extending the surface of the plates.

This was admirably illustrated by the apparatus constructed by Mr. Children, at his laboratory at Tunbridge. The plates were 6 feet long, and 2 feet 8 inches wide; they were suspended and immersed in troughs, containing diluted sulphuric and nitric acids. Wires of platina were fused instantly, and

iron heated with diamond powder was converted into steel; yet its effects upon imperfect conductors, as the human body and water, were extremely feeble.

From the powerful nature of galvanism as an agent, it was expected to be found useful in medicine, particularly in those cases where electricity has been employed; but although it has been very extensively employed, it does not appear to have produced any permanently beneficial effects.

Some time ago, the public was amused with a pretended new science, called *Perkinism*, from the name of its inventor, Dr. Perkins, of America. He imagined that he was able to produce extraordinary effects upon the human body, by the influence of pointed pieces of metal, which were presented to, or drawn over, the part of the body required to be affected. The instruments which he used for this purpose, and which were merely pieces of metal of five or six inches long, and pointed, he called *tractors*. As those who are unacquainted with the principles of science are ever ready to be led away, and made dupes of, by quacks and impostors of every description, it is no wonder that many people in this country gave credit to the stories of the extraordinary virtues of these tractors, and of the wonderful cures performed by them: and lists of these cases, apparently well attested, have been produced to confirm what has been advanced respecting their powers. But from the weakness of some, and the knavery of others, impositions are too easily practised, and pretended facts are never wanting to assist the views of the empiric. This consideration ought to render us cautious in



giving credit to every pretended discovery of the marvellous kind.

From a series of very accurate comparative experiments, made for the purpose of ascertaining the merits of the tractors, by Dr. Haygarth, it appears that if they have any effect at all it ought to be attributed entirely to imagination.

## MAGNETISM.

---

THE natural *magnet* or *loadstone* is an ore of iron, of a blackish colour, and of a stony appearance. It is worked extensively in many countries for iron; particularly in Norway and Sweden.

This substance was known to the ancients; and they had remarked its peculiar property of attracting iron, though it does not appear that they were acquainted with the wonderful property which it also has, of turning to the pole when suspended and left at liberty to move freely.

Upon this remarkable circumstance does the mariner's compass depend, an instrument which enables them to conduct their vessels through vast oceans out of the sight of land, in any given direction; and this directive property also guides the miners in their subterranean excavations, and the traveller through trackless deserts.

It is not precisely known when and by whom this directive property of the magnet was discovered. The Chinese appear to have been acquainted with it before it was known in Europe, where it first appeared in the thirteenth century.

Before that period, mariners scarcely ever ventured out of sight of land, but contented them-

selves with creeping round the coasts. In the night, and when necessity obliged them to lose sight of the shore, their only guides were the heavenly bodies.

While navigation continued so dangerous, men never would have ventured upon such voyages as those to the West Indies, America, and the South Seas, and probably the existence of those countries would have been still unknown to us. We cannot, therefore, think too highly of this extraordinary instrument, which has so much enlarged our stock of knowledge, and procured for us so many new enjoyments.

The natural loadstone has the quality of communicating its properties to iron and steel; and when pieces of steel properly prepared are touched (as it is called) by the loadstone, they are denominated *artificial magnets*.

These artificial magnets are even capable of being made more powerful than the natural ones; and as they can be made of any form, and consequently are more convenient, they are now universally used.

All magnets, whether natural or artificial, possess the following properties.

They all attract iron.

When a magnet is placed so as to be at liberty to move freely in every direction, it turns so that its ends point towards the poles of the earth, or very nearly so: and each end always points to the same pole. This is called the *polarity* of the magnet: the ends of the magnet are called *poles*, and they are called north and south poles of the magnet, according as they point to the north or south pole of the earth. When a magnet places itself in this direction, it is said to *traverse*.

When the north pole of one magnet is presented to the south of another magnet, these ends attract each other; but if the south pole of one magnet be presented to the south pole of another, or the north pole of one to the north pole of another, these ends will repel each other.

From these criteria, it is easy to determine the names of the poles of a magnetical bar, by applying it near a suspended magnet whose poles are known.

When a magnet is situated so as to be at liberty to move itself with sufficient freedom, its two poles do not lie in a horizontal direction, but it generally inclines one of them towards the horizon, and of course it elevates the other pole above it. This is called the *inclination*, or *dipping* of the magnet.

Any magnet may be made to impart those properties to iron or steel.

### *Of Magnetic Attraction and Repulsion.*

It appears at first sight that the attraction lies only in the magnet, but experiment proves this attraction between iron and it to be mutual; the iron attracting the magnet as much as the magnet attracts the iron. Place the magnet and the iron upon two separate pieces of cork, or wood, floating upon water, at a little distance from each other, and it will be found that the iron moves towards the magnet, as much as the magnet towards the iron; if the iron be kept steady, the magnet will move towards it.

This attraction is strongest at the poles of a magnet, and diminishes in proportion to the dis-

tance of any part from the poles, so that in the middle between the poles there is no attraction. This may be easily perceived by presenting a piece of iron to various parts of the surface of a magnet.

The intensity of the attractive power diminishes also, according to the distance from the magnet. The law of diminution of this attraction is not yet known. Some have imagined that it diminished in proportion to the square of the distance, others as the cube of the distance; it is only certain that the attractive force decreases faster than the simple ratio of the distances.

Soft iron easily acquires magnetism; but it lasts only a short time. With steel the case is very different; and the harder the steel is, the more permanent is the magnetism which it acquires from the influence of a magnet; but it will be in the same proportion more difficult to render it magnetic.

Neither the magnetic attraction nor repulsion is in the least diminished, or at all affected, by the interposition of any sort of bodies, except iron, or such bodies as contain iron.

The properties of the magnet are not affected either by the presence or by the absence of air. Heat weakens the power of a magnet, and subsequent cooling restores it, but not quite to its former degree. A white heat destroys it entirely, or very nearly so; and hence it appears, that the powers of magnets must be varying continually. Cavallo observes, that iron in a full red heat, or white heat, is not attracted by the magnet; but the attraction commences as soon as the redness begins to disappear.

The attractive power of a magnet may be considerably improved by hanging a weight to it, which may be gradually increased; and also by keeping it in a proper situation, viz. with its north pole towards the north, and its south pole, consequently, towards the south. On the contrary, this power is diminished by an improper situation, and by keeping too small a piece of iron, or no iron at all, appended to it.

Most probably the magnet attracts iron only; but when it is considered how universally iron is dispersed throughout nature, it is evident that a vast number of bodies must, on that account, be attracted by the magnet more or less forcibly, in proportion to the quantity and quality of the iron they contain. Indeed it is wonderful to observe, what a small portion of iron will render a body subject to the influence of the magnet. A great many substances are in a very slight degree attracted, which contain an exceeding small quantity of it, extremely diffused and oxydated.

To discover this small degree of attraction, the substances should be placed upon a piece of paper, or a thin shaving of cork, which should be put to float upon water, and then the magnet should be gently approached sideways, to within one-tenth of an inch distance from the substance under trial. The following substances will, in this manner, be found to be in some measure affected by the magnet, viz. most metallic ores, especially after having been exposed to a fire. Zinc, bismuth, and particularly cobalt, are generally attracted. The emerald, and particularly the garnet, are not only attracted, but frequently acquire permanent magnetism. The ashes of most animal and vegetable

substances are attracted; also soot, and the dust which floats in the atmosphere, are often attracted by the magnet.

Cavallo discovered, that if most specimens of brass which show no attraction towards the magnet, be hammered, they will in that hardened state (produced by the hammering) be attracted. The same piece of brass will no longer be attracted, after being softened in the fire; a second hammering will again render it attractable, and so on repeatedly. Most of the native grains of platina have the same property.

#### *Of the Polarity of the Magnet.*

Every magnet has a south and a north pole, which are at opposite ends; and a line drawn from one to the other, passes through the *centre* of the magnet. Here it must not be understood, that the polarity of a magnet resides only in two points of its surface, for in reality, it is the one half of the magnet that is possessed of one kind of polarity, and the other half of the other kind of polarity: the poles, then, are those points in which that power is the strongest.

The line drawn from one pole to the other, is called the *axis* of the magnet.

It is the *polarity* of the magnet that renders it so useful to navigators. When a magnet is kept suspended freely, so that it may turn north and south, the pilot, by looking at the position of it, can steer his course in any required direction. Thus, if a vessel is steered towards a certain place which lies exactly westward of that from which it set out, the navigator must direct it so, that its

course may be always at right angles with the direction of the magnetic needle of his compass, keeping the north end of the magnet on the right hand side, and, of course, the south end on the left hand side of the vessel; for as the needle points north and south, and the direction is east and west, the intended course of the vessel is exactly perpendicular to the position of the magnet. A little reflection will show how the vessel may be steered in any other direction.

An *artificial magnet* fitted up in a proper box, for the purpose of guiding the direction of a traveller, is called a *magnetic needle*, and the whole together, is called the *mariner's compass*.

Although the north pole of the magnet in every part of the world, when suspended, points towards the northern parts, and the south pole towards the southern parts, yet its ends seldom point exactly towards the poles of the earth. The angle in which it deviates from due north and south, is called the *angle of declination*, or the *declination of the magnetic needle*, or the *variation of the compass*; and this declination is said to be *east* or *west*, according as the north pole of the needle is eastward or westward of the astronomical meridian of the place.

This deviation from the meridian is not the same in all parts of the world, but is different in different places, and it is even continually varying in the same place. For instance, this declination is not the same in London as at Paris; and the declination in London, or in any other place, is not the same at this time as it was some years ago. This declination from the meridian is even so variable, that it may sometimes be observed to change, even in one or two hours' time.



The declination from the meridian, and the variation of this, in different parts of the world, is very uncertain, and actual trial is the only method of ascertaining it. This circumstance forms a great impediment to the improvement of navigation. Great pains have been taken by navigators, to ascertain the declination in various parts of the world, and such declinations have been marked in maps, charts, books, &c. ; but still, on account of the constant change to which this variation is liable, these can only serve for a few years; nor has the law of this variation been yet discovered. When the variation was first observed, the north pole of the magnetic needle declined eastward of the meridian of London; but it has since that time been changing continually towards the west; so that in the year 1657, the magnetic needle pointed due north and south. At present, it declines about  $24\frac{1}{2}^{\circ}$  westward, and it seems to be still advancing towards the west.

Before volcanic eruptions and earthquakes, the magnetic needle is often subject to very extraordinary movements.

It is also agitated before and after the appearance of the aurora borealis.

The variation of the compass was first observed by Columbus, in his voyage in which he discovered America: and his sailors were very much alarmed in consequence of it; thinking the compass would fail in directing their route.

#### *Of the Magnetic Inclination, or Dip of the Needle.*

If a needle which is accurately balanced, and suspended so as to turn freely in a vertical plane,

be rendered magnetical, the north pole will be depressed, and the south pole elevated above the horizon: this property is called the *inclination* or *dip of the needle*.

Cavallo gives the following method of illustrating this: take a globular magnet, or, what is more easily procured, an oblong one, and place it horizontally upon a table; then take another small oblong magnet, and suspend it by means of a thread tied to its middle, or centre of gravity, so that it will remain in an horizontal position, when not disturbed by the vicinity of iron, or other magnets. Now bring this small magnet held by the thread, just over the middle of the large magnet, and within two or three inches of it; the former will turn its south pole towards the north pole of the large magnet, and its north pole towards the south pole of the large one.

It will be also noticed, that the small magnet, whilst kept just over the middle of the large one, will remain parallel to it; for since the poles of the small magnet are equally distant from the contrary poles of the large magnet, they are equally attracted; but if the small magnet be brought a little nearer to one end than to the other of the large magnet, then one of its poles, namely, that which is nearest to the contrary pole of the large magnet, will be inclined downwards, and, of course, the other pole will be elevated above the horizon. This inclination, it is evident, must increase according as the small magnet is placed nearer to one of the poles of the large one, because the attraction of the nearest pole will have more power upon it. If the small magnet be brought just opposite to one of the poles of the large one, it will turn the contrary pole towards

it, and will place itself in the same straight line with the axis of the large magnet.

This simple experiment will enable the reader to comprehend easily the phenomena of the magnetic inclination, or of the *dipping needle*, upon the surface of the earth; for it is only necessary to imagine that the earth is a large magnet (as in fact it appears to be), and that any magnet, or magnetic needle commonly used, is the small magnet employed in the above-mentioned experiment; for, supposing that the north pole of the earth is possessed of a south magnetic polarity, and that the opposite pole is possessed of a north magnetic polarity, it appears evident, and it is confirmed by actual experience, that when a magnet, or magnetic needle, properly shaped and suspended, is kept near the equator of the earth, or, more properly speaking, near the magnetic equator of the earth (since neither the magnetic equator, nor the magnetic poles of the earth, coincide with its real equator and poles), it must remain in an horizontal situation: if the magnet be removed nearer to one of the magnetic poles of the earth, it must incline to one of its extremities namely, that which is possessed of the contrary polarity; and this inclination must increase in proportion as the needle recedes from the magnetic equator of the earth. Lastly, when the needle is brought exactly over one of the magnetic poles of the earth, it must stand perpendicular to the horizon of that place.

The directive property and dipping of the needle upon the surface of the earth is exactly analogous to that of a small magnet upon the surface of a small globe, having a magnet inclosed within it, which apparatus is called a *terrella*.

A magnetical needle constructed for the purpose of showing this property is called a *dipping needle*.

If the geographical poles of the earth (that is, the ends of its axis) coincided with its magnetic poles, or even if the magnetic poles were constantly at the same distance from them, the inclination of the needle, as well as its declination, would always be the same; and hence, by observing the direction of the magnetic needle in any particular place, the latitude and longitude of that place might be ascertained; but this is not the case, for the magnetic poles of the earth do not coincide with its real poles, and they are also constantly shifting their situations; hence the magnetic needle changes continually and irregularly, not only in its horizontal direction, but likewise in its inclination, according as it is removed from one place to another, and also while it remains in the same place.

This change of the dip in the same place, however, is very small. In London, about 1576, the north pole of the dipping needle stood  $71^{\circ} 50''$  below the horizon; and in 1775, it stood at  $72^{\circ} S'$ , the whole change of inclination, during so many years, amounting to less than a quarter of a degree.

#### *The Magnetic Touch, or communicated Magnetism.*

When a piece of iron comes sufficiently near to a magnet, it becomes itself a magnet; and this magnetism is more easily communicated to, but, at the same time, more easily lost, by soft iron than by steel.

There are various methods of giving the magnetic property to steel or iron, but for all these a magnet is necessary.

If you merely take a bar of iron three or four feet long, and hold it in a vertical position, you will find that the bar is magnetic, and will act upon another magnet; the lower extremity of the bar attracting the south pole, and repelling the north pole. If you invert the bar, the polarity will be instantly reversed; the extremity which is now lowest, will be found to be a north pole, and the other extremity will be a south pole.

This is easily explained, by supposing the earth is itself to be a great magnet, and that the bar is placed, by holding it nearly vertical, in the magnetical line, viz. in the direction of the dipping needle.

A bar of hard iron, or steel, will not answer for the above experiment, the magnetism of the earth not being sufficient to magnetize it.

Bars of iron that have stood in a perpendicular position are generally found to be magnetical, as fire-irons, bars of windows, &c.

Striking an iron bar with a hammer, or rubbing it with a file, while held in this direction, likewise renders it magnetical. An electric shock produces the same effect; and lightning often renders iron magnetic.

A magnet cannot communicate a degree of magnetism stronger than that which itself possesses; but two or more magnets joined together, may communicate a greater power to a piece of steel, than either of them possesses singly: hence we have a method of constructing very powerful magnets, by first constructing several weak magnets, and then joining them together to form a

compound magnet, to act more powerfully upon a piece of steel.

Various processes have been employed for this purpose ; the following may suffice.

Place two magnetic bars, AB (Plate 21. fig. 16.), in a line with the north, or marked end of one, opposed to the south, or unmarked end of the other, but at such a distance from each other, that the magnet to be touched may rest with its marked end on the unmarked end of A, and its unmarked end on the marked end of B; then apply the north end of the magnet D, and the south end of E, to the middle of the bar C, the opposite ends being elevated as in the figure; draw D and E asunder along the bar C, one towards A, the other towards B, preserving the same elevation; remove D and E a foot or two from the bar when they are off the ends, then bring the north and south poles of these magnets together, and apply them again to the middle of the bar C as before; repeat the same process five or six times, then turn the bar, and touch the opposite surface in the same manner, and afterwards the two remaining surfaces; by this means the bar will acquire a strong fixed magnetism.

The following is also recommended by Cavallo :

Place the two bars which are to be touched parallel to each other, and then unite the ends by two pieces of soft iron, called supporters, in order to preserve, during the operation, the circulation of the magnetic matter; the bars are to be placed so that the marked end D (Fig. 17.) may be opposite the unmarked end B; then place the two attracting poles G and I on the middle of one of the bars to be touched, raising the ends, so that the bars may form an obtuse angle of 100 or 120

degrees ; the ends G and I of the bars are to be separated two or three tenths of an inch from each other. Keeping the bars in this position, move them slowly over the bar AB, from one end to the other, going from end to end about fifteen times. Having done this, change the poles of the bars (*i.e.* the marked end of one is always to be against the unmarked end of the other), and repeat the same operation on the bar CD, and then on the opposite faces of the bars. The touch thus communicated may be further increased, by rubbing the different faces of the bars with sets of magnetic bars, disposed as in Fig. 18.

In these operations all the pieces should be well polished, the sides and ends made quite flat, and the angles quite square.

A magnet, bent so that the two ends almost meet, is called a *horse-shoe magnet*. To render it magnetic, place a pair of magnetic bars against the ends of the horse-shoe, with the south end of the bar against that of the horse-shoe which is intended to be the north, and the north end of the bar to that which is to be the south : the contact, or lifter of soft iron, to be placed at the other end of the bars. Also rub the surfaces of the horse-shoe with a pair of bars placed in the form of a compass, or with another horse-shoe magnet, turning the poles properly to the poles of the horse-shoe magnet ; being careful that these bars never touch the ends of the straight bars. If the bars are separated suddenly from the horse-shoe magnet, its force will be considerably diminished : to prevent this, slip on the lifter, or support, to the end of the horse-shoe magnet, but in such a manner, however, that it may not touch the bars ; the

bars may then be taken away, and the support slid to its place.

Magnetism is best communicated to compass-needles by the following method.

Procure a pair of magnetic bars, not less than six inches in length. Fasten the needle down on a board, and with a magnet in each hand, draw them from the centre upon the needle outwards; then raise the bars to a considerable distance from the needle, and bring them perpendicularly down upon the centre, and draw them over again. This operation repeated about twenty times will magnetize the needle, and its ends will point to the poles contrary to those that touched them.

In communicating magnetism, it is best to use weak magnets first, and those that are stronger afterwards; but you must be very careful not to use weak after strong magnets.

A magnet loses nothing of its own power by communicating to other substances, but is rather improved thereby.

Every kind of violent percussion weakens the power of a magnet. A strong magnet has been entirely deprived of its virtue, by receiving several smart strokes of a hammer; indeed, whatever deranges or disturbs the internal pores of a magnet, will injure its magnetic force.

Fill a small dry glass tube with iron filings, press them in rather close, and then touch the tube as if it were a steel bar, and the tube will attract a light needle; shake the tube, so that the situation of the filings may be disturbed, and the magnetic virtue will vanish.

Magnets should never be left with two north, or two south poles together; for when they are thus



placed, they diminish and destroy each other's power. Magnetic bars should therefore be always left with the opposite poles laid against each other, or by connecting their opposite poles by a bar of iron. The power of a magnet is increased by letting a piece of iron remain attached to one or both of its poles. A single magnet should therefore be always thus left.

The *mariner's compass* consists of three parts; the box, the card or fly, and the needle. The box is made of a circular form, and either of wood, brass, or copper. It is suspended within a square wooden box, by means of two concentric circles called *gimbalds*, so fixed by cross axes to the two boxes, that the inner one, or compass-box, shall retain a horizontal position in all motions of the ship, whilst the outer or square box is fixed with respect to the ship. The compass-box is covered with a pane of glass, in order that the motion of the card may not be disturbed by the wind. The card is a circular piece of paper, which is fastened upon the needle, and moves with it. Sometimes there is a slender rim of brass, which is fastened to the extremities of the needle, and serves to keep the card stretched. The outer edge of this card is divided into 360 degrees, and also into 32 equal parts or arcs, which are called the *points of the compass*, or *rhumbs*, each of which is often subdivided into quarters. The letters &c. are annexed to those rhumbs, to denote the north, north-east, &c.

The *needle* is a slender bar of hardened steel, having a hole in the middle, to which a conical piece of agate is adapted, by means of a brass piece into which the agate case is fastened. The apex of this hollow cap rests upon the points of a

pin which is fixed in the centre of the box, and upon which the needle, being properly balanced, turns very easily. For common compasses, the needles have a conical perforation made in the steel itself, or in a piece of brass which is fastened in the middle of the needle.

The needle, which is balanced before it is magnetized, will lose its balance by that process, on account of the dipping; therefore, a small weight, or moveable piece of brass, is placed on one side of the needle, by the shifting of which, either nearer to, or farther from, the centre, the needle will always be balanced.

The *azimuth compass* is one to which two sights are adapted, through which the sun is to be seen, in order to find its azimuth, and from thence to ascertain the declination of the magnetic needle at the place of observation.

The cause of magnetism is entirely unknown to us, nor has any thing farther than mere hypotheses been advanced to account for this, as well as every other species of attraction.

Aepinus supposed that there exists a peculiar fluid, which he called the *magnetic fluid*, so subtile as to penetrate all bodies; that its particles are repulsive of each other; also, that there is a mutual attraction between this fluid and iron, but that no other substance has any action upon it.

## ASTRONOMY.

OF the various branches of science cultivated by mankind, astronomy is one of the most important and useful. Our faculties are enlarged by the grand ideas it excites, and the mind is exalted above the contracted prejudices of the vulgar. By the knowledge of this science, we discover the bulk of the earth, and ascertain the situation and extent of the countries and kingdoms into which it is divided: by aiding the navigator, and facilitating his passage through the trackless ocean, commerce is carried on to the most remote parts of the world.

Upon examining the heavens, the first and most obvious phenomenon that presents itself to observation, is the apparent diurnal motion of the sun, moon, and stars, or that by which they are seen to rise and set once in twenty-four hours.

If, to consider more attentively the circumstances of this diurnal motion, you place yourself in an elevated situation, you perceive a circle terminating your view on all sides, by the apparent meeting of the earth and heavens. This circle is called the *horizon*: it divides the heavens into two parts; that which is above the horizon only is visible; and this appears to us like a concave hemisphere, which we call the *sky*, in which we

see the heavenly bodies move. The sky is not a real substance; the blue colour is only owing to the refraction of the rays of light which pass through the atmosphere.

On considering with attention, for one or more nights, the motions of the stars, you find each star describing a circle in about twenty-four hours. Those stars that appear northward describe smaller circles than those that are more to the south. If you look towards the south, you observe some stars just appearing above the horizon, grazing this circle, but not rising above it, and then vanishing; others, a little farther from the south, rise above the horizon, making a small arc, and then go down; while some again describe a larger arc, and take a longer time in setting. If you now turn to the north, you will find that some just skim the horizon, mount to the top of the heavens, and then descend, and again touch the horizon and mount, without ever disappearing. Others, that are higher, describe complete circles in the sky, without coming to the horizon; and these circles diminish, till at last we arrive at a star that scarce seems to move from the point where it is stationed, the rest wheeling round it.

It may be easily conceived, that as there is a hemisphere above, there is also another beneath, though invisible; and that, of course, the horizon is a great circle of the sphere, dividing the concave heavens into two parts, the visible above, and the invisible below. The general appearance, therefore, of the starry heavens, is that of a vast concave sphere turning round two fixed points diametrically opposite to each other; the one in the northern hemisphere visible to us, and the other in the southern hemisphere.

The fixed points round which this sphere is supposed to turn are the *poles*; a line drawn from one to the other is called the *axis* of the sphere; and round this line the heavens seem to turn every day.

To understand this more clearly, we must have recourse to a figure, or diagram. Let H O (Plate 23. fig. 1.), represent the circle of the horizon, seen edgeways, when it will appear as a straight line; let H P F O R Q be the complete sphere of the heavens, of which we shall suppose H P E O to be the visible hemisphere, and H Q R O the invisible hemisphere; then P will be the *pole*, or fixed point, among the stars, visible to us, round which they all appear to turn; and R will be the opposite pole, or fixed point, in the sphere; the line P R will be the axis of the sphere. If through the centre of the sphere C, there be drawn a line Q E, it will represent the edge of a great circle, at equal distances from both poles, and at right angles to the axis called the *equator*, because it divides the heavens into two equal parts.

If H O be the horizon, the highest point, or that immediately over our heads, as M, is called the *zenith*; and the opposite point in the sphere, or lowest point N, is called the *nadir*.

The rising and setting of the sun are the two most remarkable circumstances to be observed in the heavens. He rises in the east, mounts to the highest point in the arch which he describes, and descends in the west. The highest point to which he reaches is naturally called the *mid-day point*. If a great circle be traced through this point and the zenith, it is called the *meridian* of the place; and all the stars must cross this circle, or meridian, twice in the twenty-four hours; but those that go

below the horizon are seen only to cross it once, because when they cross it a second time they are invisible.

Three great circles are thus established in the heavens; the horizon, the equator, and the meridian. The first determines the rising and setting of the heavenly bodies, and also the *altitude* of any of them, at any time of their course. For this purpose you must suppose another great circle to pass through the star and the zenith; it will, consequently be perpendicular to the horizon. This is called a *vertical circle*, and upon this circle we reckon the number of degrees which the star is distant from the horizon. The *quadrant* is an instrument for measuring the number of degrees of altitude which any body has.

The three great circles mentioned above form the basis of all observations upon the heavenly bodies, and to them all their situations must be referred. It is necessary, therefore, to determine the relative situations of these circles. If the polar star had been accurately at the pole of the heavens, nothing more would be necessary, in order to obtain the altitude of the pole, but to take the altitude of this star; but this star is situated  $2^{\circ}$  distant from the pole:  $2^{\circ}$  must, therefore, be added to this altitude to find that of the pole.

The elevation of the pole being discovered, it is easy to find that of the equator. Thus, in the diagram (Fig. 1.), H M O, or the visible part of the heavens, contains  $180^{\circ}$ ; but it is  $90^{\circ}$  from the pole P, to E the equator. If you take away P E from the semi-circle H M O, there remains  $90^{\circ}$  for the other two arcs; or in other words, the elevation of the pole and the equator, are together equal to  $90^{\circ}$ ;

so that the one being known, and subtracted from  $90^\circ$ , it will give the other; therefore, the *elevation of the pole at any place is the complement of the elevation of the equator*, or what that elevation wants of  $90^\circ$ . It follows from hence, that the elevation of the equator is equal to the distance from the pole to the zenith; for the elevation of the equator is the difference between that of the pole and  $90^\circ$  (the same elevation subtracted from  $90^\circ$ , gives its distance from the zenith). A little attention will soon convince you, that the sun does not rise always at the same point of the heavens. Thus, if you commence your observations on the sun, for instance in the beginning of March, you will find him appear to rise more to the northward every day, to continue longer above the horizon, and to be more vertical or higher at mid-day. This continues till towards the end of June, when he moves backward in the same manner, and continues this retrograde motion till near the end of December, when he begins to move forward, and so on. It is from this change in the sun's place, and from his height being so much greater in summer than in winter, that the different length of the days and nights, and the vicissitudes of seasons are owing. We cannot observe the sun's motion among the fixed stars, because he darkens the heavens by his splendor, and effaces the feeble light of those stars that are in his neighbourhood; but we can observe the instant of his coming to the meridian, and his meridional altitude; we can also compute what point of the starry heavens comes to the same meridian at the same time, and with the same altitude. The sun must be at that point of the starry heavens thus discovered. Or, we can observe that point in the heavens which comes to the meridian

at midnight, with a declination as far from the equator on one side as the sun's is on the other side; and it is evident the sun must be in that part of the heavens which is diametrically opposite to this point. By either of these methods you may obtain a series of points in the heavens through which the sun passes, forming a circle called the *ecliptic*. This circle has its name from thence, that all the eclipses of the sun and moon are performed either actually in, or very near the circumference of that circle.

To conceive this combined annual and diurnal motion of the sun, suppose a globe to represent the celestial sphere. Place an insect upon it at an equal distance from both the poles, and turn the globe upon its axis: the insect will turn with the globe, and describe the equator. But while the globe is moving in one direction, the insect may be moving very slowly in another, and will thereby imitate the annual motion of the sun, which advances by degrees towards the east, though it is carried round every day by the diurnal motion towards the west.

The ecliptic, or annual path of the sun, differs in situation from the equator; for the sun rises above the equator in summer, and does not rise so high in winter. The points of the ecliptic, where the sun is situated when he is most distant from the equator, are called *solstitial points*; and the distance between the equator and the ecliptic at the solstitial points, is called the *obliquity of the ecliptic*; this is found to be about  $23\frac{1}{2}^{\circ}$ . A B (Fig. 1.) represents the ecliptic inclined  $23\frac{1}{2}^{\circ}$  to the equator.

The *equinoctial colure* is the great circle which passes at right angles to the equator, through those



two points of it that are intercepted by the ecliptic, called the *equinoctial points*. The *solstitial colure* is the other great circle at right angles to the equator, cutting it in the solstitial points. It passes through the poles of the ecliptic.

If smaller circles of the sphere be described touching the solstitial points, and at right angles to the *axis*, as M C, B D, they are *tropics*, of which that on the south side of the equator is called the *tropic of Capricorn*, and that on the north side of the equator the *tropic of Cancer*. The two *polar circles* F G, I K, are at the same distance from the two as the tropics are from the equator, that is,  $23\frac{1}{2}^{\circ}$ .

It is necessary here to mention the difference between what is called the *sensible* and *rational* horizon. If you suppose that part of the surface of the earth on which you stand to be a plane, and to be extended every way till it reach the heavens, this plane forms the *sensible* horizon. The *rational* horizon is a circle whose plane is parallel to the former, but passing through the *centre* of the earth. Though the globe of the earth appears so large to those who inhabit it, yet it is so small when compared with the immense sphere of the heavens, that the distance between the sensible and rational horizons is nothing in comparison with it.

The *zodiac* is a broad portion of the heavens, which stretches about  $8^{\circ}$  on each side of the ecliptic; it is divided into twelve parts, called *signs*, and each sign into  $30^{\circ}$ . If you imagine a number of great circles of the sphere standing at right angles to the plane of the ecliptic, and, consequently, intersecting each other in its poles, these are called *circles of celestial longitude*, and

they will divide the ecliptic into equal parts. Upon the ecliptic is reckoned the *longitude* of any fixed star, beginning to reckon at that point where the ecliptic and the equator intersect each other in the vernal equinox, called the first point of Aries; and the arch of any of the circles of celestial longitude intercepted between any star and the ecliptic, is the *latitude* of that star. The equator is divided into degrees, but they are called degrees of *right ascension*; and from it to the poles the degrees of *declination* are reckoned upon the meridian of the place.

We have now described the principal lines and points on the celestial sphere, as generated by the apparent motions of the heavenly bodies, in which we have supposed what appears at first sight to be the case, viz. the earth stands still while all the heavenly bodies revolve round it. This will make no difference with regard to these circles in the heavens; for it will be the same thing with respect to them, whether the earth be at rest, and the heavenly bodies move round it, or whether the latter remain still, and the earth, as we shall afterwards see, move round its axis once every twenty-four hours.

The earth, upon which we live, was long considered as an extensive plane, and mankind had an obscure notion of its being supported on some sort of scaffolding or pillars, though they could not tell what supported these. The heavens above it, in which the sun, moon, and stars, appeared to move daily from east to west, were conceived to be at no great distance from it, and to be only designed for the use and ornament of our earth. The natives of India and the Eastern countries appear to have

been the first who paid much attention to astronomy, and its antiquity among them is very great. Mankind must have made considerable improvement in observing the motions of the heavenly bodies, before they could so far disengage themselves from the prejudices of sense and popular opinion, as to believe that the earth was not fixed and immoveable. We find, however, that Thales, the Milesian, had, 580 B. C. taught the manner of calculating eclipses; and even the present system, called the Copernican, because afterwards revived by Copernicus, was publicly taught in Greece by Pythagoras, who probably learned it in the East. This system was retained till Aristotle and his disciples adopted the vulgar idea, which had been embraced by Ptolemy, an Egyptian, about the year 140. He supposed that the earth was immovable in the centre of the universe, and that the planets were placed near it; above them was the firmament of fixed stars, then the crystalline orbs, then the primum mobile, and last of all, the cœlum empyrium, or heaven of heavens. All these vast orbs he supposed to move round the earth in twenty-four hours. This system, absurd as it was, continued to be believed till Copernicus, a native of Poland, revived that of Pythagoras in the year 1530. Europe was then immersed in ignorance, and this system was forbid by the clergy to be taught, as being a heresy. The Reformation permitted it again to gain ground, and the discoveries of various astronomers, but particularly those of Sir Isaac Newton, assisted by the invention of telescopes, have placed it upon the firmest basis, and it is now universally received.

If you examine the heavens in a clear night, you will discover some stars which have brighter and

steadier light than the rest; and if you continue to observe these for several nights, you will find that they do not appear in the same place among the rest of the stars every night, but that they have motions peculiar to themselves. All the rest of the stars rising and setting always exactly in the same places, are called *fixed stars*. Those wandering or moving stars are called *planets*.

It is now fully proved, that these planets, with the earth which we inhabit, and also the moon, revolve round the *sun*, which is fixed in the centre of the system. There are two kinds of planets, *primary* and *secondary*. The first move round the sun, and respect him only as the centre of their motions. The secondary planets, called also *satellites* or *moons*, are smaller planets, revolving round the primary, while they, with the primary planets about which they move, are carried round the sun. The planets move round the sun at various distances, some being much nearer to him than our earth, and others being much farther off.

There are nine primary planets, which are situated with respect to their distances from the sun as follows: *Mercury* ☿, *Venus* ♀, the *Earth* ⊕, *Mars* ♂, *Ceres*, *Pallas*, *Harding*, *Jupiter* ♃, *Saturn* ♄, and *Herschell* or the *Georgium Sidus* ♃.

Of these, our earth is accompanied by one moon; Jupiter has four moons; Saturn has seven moons; and the Georgian planet has six moons. None of these moons, except our own, can be seen without a good telescope. The other five planets do not appear to have any satellites or moons.

All the planets move round the sun from east to west, and in the same direction do the moons revolve round their primaries, excepting those of

the Georgian planet, which seem to move in a contrary direction. The paths in which they move round the sun is called their *orbits*. These orbits are elliptical, but the eccentricity of the ellipses is so small, that they approach very nearly to circles. They perform their revolutions also in very different periods of time. The time of performing their revolutions is called their *year*.

TABLE OF THE SOLAR SYSTEM.

	Apparent mean Di- ameters, as seen from the Earth.	Mean Di- ameters, in English Miles.	Mean Dis- tances from the Sun, in round Num- bers of Miles.	Diurnal Rotations, or round their own Axes.	Time of revolving round the Sun.	Inclination of the Orbits of the Eclip- tic.	Inclination of the Axes to the Orbits
The Sun .....	32'.1",5	883,246	—	25d. 14h. 8m.	—	—	82° 44' 0"
Mercury .....	10"	3224	37,000,000	unknown.	83d. 23h. 16m.	7° 0'	unknown.
Venus .....	58'	7867	68,000,000	0d. 23h. 21m.	224 16 49	3 23 35	unknown.
The Earth.....	—	—	95,000,000	1d.	365 6 9	—	66° 32' 0
The Moon.....	31'.8"	2180	95,000,000	29d. 17h. 44m. 3s.	—	5 9 3	88 17 0
Mars .....	27'	4189	144,000,000	0 24 39 22	686 23 30½	1 51 0	59 22 0
Ceres Ferdinandea	1"	160	260,000,000	unknown.	unknown.	10 37 56	unknown.
Pallas .....	0",5	80	266,000,000	unknown.	1703d 16h. 48m.	34 50 40	unknown.
Harding.....	—	—	—	—	—	—	—
Jupiter .....	39"	89,170	490,000,000	0d. 9h. 55m. 37s.	4332 14 27	1 18 56	90° 0 0
Saturn .....	18"	79,012	900,000,000	0 10 16 2	10759 1 51	2 29 50	60° 0 0
Georgium Sidus...	3" 54	35,112	1,800,000,000	unknown.	30737 18 0	0 46 20	unknown.

The planets are evidently opaque bodies, and they shine only by reflecting the light which they receive from the sun; for Mercury and Venus, when viewed by a telescope, often appear to be only partly illuminated, and have the appearance of our moon when she is cusped or *horned*, having the illumined part always turned towards the sun. From the appearance of the boundary of light and shadow upon their surfaces, we conclude that they are spherical, which is confirmed by most of them having been found to turn periodically on their axes.

Venus and Mercury, being nearer to the sun than our earth, are called *inferior* planets; and all the rest, which are without the earth's orbit, are called *superior* planets. That the first go round the sun is certain, because they are seen sometimes passing between us and the sun, and sometimes they go behind it. That their orbits are within that of the earth is evident; because they are never seen in *opposition* to the sun, that is, appearing to rise from the horizon when the sun is setting. On the contrary, the orbits of all the other planets surround that of the earth; or they sometimes are seen in opposition to the sun; and they never appear to be horned, but always nearly or quite full, though sometimes they appear a little *gibbous*, or somewhat deficient from full.

We mentioned above, that all the planets move round the sun in elliptical orbits. The sun is situated in one of the foci of each of them. That focus is called the *lower focus*. If we suppose the plane of the earth's orbit, which passes through the centre of the sun, to be extended in every direction, as far as the fixed stars, it will mark out among them a great circle, which is the *ecliptic*;

and with this the situations of the orbits of all the other planets are compared.

The planes of the orbits of all the other planets must necessarily pass through the centre of the sun ; but if extended as far as the fixed stars, they form circles different from one another, as also from the ecliptic ; one part of each orbit being on the north, and the other on the south side of the ecliptic. Therefore the orbit of each planet cuts the ecliptic in two opposite points, which are called the *nodes* of that particular planet ; and the nodes of one planet cut the ecliptic in planes different from the nodes of another planet. A line passing from one node of a planet to the opposite node, or the line in which the plane of the orbits cuts the ecliptic, is called the *line of nodes*. That node where the planet passes from the south to the north side of the ecliptic, is called the *ascending node* ; and the other is the *descending node*. The angle which the plane of a planet's orbit makes with the plane of the ecliptic, is called the *inclination* of that planet's orbit. Thus (Fig. 2.), where F represents the sun, the points A and B represent the *nodes*, and the line A B the line of nodes formed by the intersection of the planes of the orbits C and D. The angle E F G, is the angle of inclination of the planes of the two orbits to each other. A line drawn from the lower focus of a planet's orbit (viz. where the sun is) to either end of the conjugate axis of its orbit (which line is equal to half the transverse axis), is called the *mean distance* of the planet from the sun. But according to some, the *mean distance* is a mean proportional between the two axes of that planet's orbit. The distance of either focus from the centre of the orbit is called its *eccentricity*.



The two points in a planet's orbit which are farthest and nearest to the body round which it moves, are called the *apses*, or *apsides*; the former of which is called the *higher apsis*, or *aphelion*; the latter is called the *lower apsis*, or *perihelion*. The diameter which joins these two points is called the *line of the apsides*. When the sun and moon are nearest to the earth, they are said to be in *perigee*; when at their greatest distance from the earth, they are said to be in *apogee*.

When a planet is situated so as to be between the sun and the earth, or so that the sun is between the earth and the planet, then that planet is said to be in *conjunction* with the sun. When the earth is between the sun and any planet, then that planet is said to be in *opposition*. It is evident that the two inferior planets must have two conjunctions with the sun, and the superior planets can have only one, because they can never come between the earth and the sun. When a planet comes directly between us and the sun, it appears to pass over the sun's *disc*, or surface, and this is called the *transit* of the planet. When a planet moves from west to east, viz. according to the order of the signs, it is said to have *direct motion*, or to be in *consequentia*. Its *retrograde motion*, or motion in *antecedentia*, is when it appears to move from east to west, viz. contrary to the order of the signs.

The place that any planet appears to occupy in the celestial hemisphere, when seen by an observer supposed to be placed in the sun, is called its *heliocentric place*. The place it occupies, when seen from the earth, is called its *geocentric place*.

The planets do not move with equal velocity in every part of their orbits; but they move faster

when they are nearest to the sun, and slower in the remotest part of their orbits ; and they all observe this remarkable law, that if a straight line be drawn from the planet to the sun, and this line be supposed to be carried along by the periodical motion of the planet, then the areas which are described by this right line and the path of the planet are proportional to the times of the planet's motion. That is, the area described in two days, is double that which is described in one day, and a third part of that which is described in six days ; though the arcs or portions of the orbit described are not in that ratio.

The planets being at different distances from the sun, perform their periodical revolutions in different times ; but it has been found that the cubes of their mean distances are constantly as the squares of their periodical times ; viz. of the times of their performing their periodical revolutions.

These two last propositions were discovered by Kepler, by observations on the planets ; but Sir Isaac Newton demonstrated, that it must have been so on the principle of *gravitation* which formed the basis of his theory. This law of *universal attraction*, or gravitation, discovered by Newton, completely confirms the system of Copernicus, and accounts for all the phenomena which were inexplicable on any other hypothesis.

The sun, as the largest body in our system, forms the centre of attraction, round which all the planets move ; but it must not be considered as the only body endued with attractive power, for all the planets also have the property of attraction, and act upon each other as well as upon the sun. The actual point, therefore, about which they move, will be the common centre of gravity of all

the bodies which are included in our system; that is, the sun, with the primary and secondary planets. But because the bulk of the sun greatly exceeds that of all the planets put together, this point is in the body of the sun. The attraction of the planets on each other also somewhat disturbs their motions, and causes some irregularities.

It is this mutual attraction between them and the sun that prevents them from flying off from their orbits by the centrifugal force which is generated by their revolving in a curve; while the centrifugal force keeps them from falling into the sun by the force of gravity, as they would do if it were not for this motion impressed upon them. Thus these two powers balance each other, and preserve order and regularity in the system.

It has been already mentioned, (page 18) that if, when a body is projected in a straight line, it be acted upon by another force drawing it towards a centre, it will be made to describe a curve, which will be either a circle or an ellipsis, according to the proportion between the projectile and centripetal force. If a planet at B (Plate 23. fig. 3.,) gravitates or is attracted towards the sun S, so as to fall from B to  $y$ , in the time that the projectile force would have carried it from B to X, it will describe the curve B Y, by the combined action of these two forces, in the same time that the projectile force singly would have carried it from B to X, or the gravitating power singly have caused it to descend from B to  $y$ ; and these two forces being duly proportioned, the planet obeying them both, will move in the circle B Y T V.

But if, whilst the projectile force would carry the planet from B to  $b$ , the sun's attraction should bring it down from B to  $l$ , the gravitating power

would then be too strong for the projectile force, and would cause the planet to describe the curve BC. When the planet comes to C, the gravitating power (which always increases as the square of the distance from the sun S diminishes) will be yet stronger for the projectile force, and by conspiring in some degree therewith, will accelerate the planet's motion all the way from C to K, causing it to describe the arcs BC, CD, DE, EF, &c. all in equal times.

Having its motion thus accelerated, it thereby acquires so much centrifugal force, or tendency to fly off at K, in the line K *k*, as overcomes the sun's attraction; and the centrifugal force being too great to allow the planet to be brought nearer to the sun, or even to move round him in the circle *k l m n*, &c. it goes off, and ascends in the curve K L M N, &c. its motion decreasing as gradually from K to B, as it increased from B to K, because the sun's attraction now acts against the planet's projectile motion, just as much as it acted with it before.

When the planet has got round to B, its projectile force is as much diminished from its mean state as it was augmented at K; and so the sun's attraction being more than sufficient to keep the planet from going off at B, it describes the same orbit over again, by virtue of the same forces or powers.

A double projectile force will always balance a quadruple power of gravity. Let the planet at B have twice as great an impulse from thence towards X, as it had before; that is, in the same length of time that it was projected from B to *b*, as in the last example, let it now be projected from B to *c*; and it will require four times as

much gravity to retain it in its orbit; that is, it must fall as far from B to 4, in the time that the projectile force would carry it from B to c, otherwise it would not describe the curve B D, as is evident from the figure. But in as much time as the planet moves from B to C, in the higher part of its orbit, it moves from I to K, or from K to L, in the lower part thereof; because from the joint action of these two forces it must always describe equal areas in equal times throughout its annual course. These areas are represented by the triangles B S C, C S D, D S E, E S F, &c. whose contents are equal to one another from the properties of the ellipsis.

We have now given a general idea of the solar system; we shall next describe the bodies that compose it.

The *Sun* was long considered, from its constant emanation of heat and light, as an immense globe of fire. When viewed through a telescope, several dark spots are visible on its surface, which are of various sizes and durations. From the motion of these spots, the sun has been found to move round its axis, and its axis is found to be inclined to the ecliptic.

Various opinions have been formed respecting these spots; they have been considered as opaque islands in the liquid igneous matter, and by some as pits or cavities in the body of the sun. In 1788, Mr. King published a dissertation on the sun, in which he advanced, that the real body of the sun is less than its apparent diameter; that we never discern the real body of the sun itself, except when we behold its spots; that the sun is inhabited as well as our earth, and is not necessarily subject to burning heat, and that there is in reality

no violent elementary heat existing in the rays of the sun themselves essentially, but that they produce heat only when they come into contact with the planetary bodies.

Several years after this, Herschell published his theory of the nature of the sun, which is briefly as follows. He considers the sun as a most magnificent habitable globe, surrounded by a double set of clouds; those which are nearest its opaque body are less bright, and more closely connected together, than those of the upper stratum, which form the luminous apparent globe we behold: this luminous external matter is of a phosphoric nature, having several accidental openings in it, through which we see the sun's body, or the more opaque clouds beneath: these openings form the spots we see.

*Mercury*.—This planet being the nearest to the sun, and the least in magnitude, is very seldom visible. It never appears more than a few degrees from the sun's disc, and is generally lost in the splendour of the solar beams. On this account, astronomers have had few opportunities of making accurate observations upon it; no spots have been observed upon it, consequently, the time of its rotation on its axis is not known. Being an inferior planet, it consequently must show phases like the moon; and it never appears quite full to us. It is seen sometimes passing over the sun's disc, which is called its transit.

*Venus* is the brightest and largest to appearance of all the planets, and is distinguished from the rest by her superiority of lustre. It is generally called the morning or evening star, according as it precedes or follows the apparent course of the sun. Some have thought that they could discover spots

upon its disc; but Herschell has not been able to see them; consequently, the time of rotation round its axis is not decidedly known. Venus also appears with phases, and transits sometimes take place, which are of very great importance in astronomy.

*The Earth* which we inhabit is a globular body, as may be proved from a variety of circumstances, the chief of which we shall here enumerate. It is always observed by mariners, that as they sail from any high objects, such as mountains, steeples, &c. they first begin to lose sight of the lower part of those objects, and then gradually of the higher parts; also, persons on shore first discover the upper parts of the masts of approaching vessels. This could not be the case if the earth were a plane, but is very easily accounted for on the supposition of its being a sphere, as will be easily understood by examining Fig. 4. Also various navigators have sailed completely round the earth, by continuing in the same direction, at last coming to the same place from which they set out.

The earth, however, is not a perfect sphere, but a spheroid, having its equatorial diameter longer than the polar diameter, or axis. It is, consequently, flattest at the poles, and more protuberant at the equator. The diameter at the equator is 7893 English miles; that at the poles is 7928 miles. The surface of the earth is much diversified with mountains and vallies, land and water. The highest mountains in it are the Andes in South America, and the Himala mountains in the East Indies, some of which are about four miles in perpendicular altitude. About two-thirds of the globe is covered with water.

In consequence of the earth's being a globe, people standing upon opposite sides of it must have their feet towards each other. When in this situation, they are called *antipodes* to each other. Hence it appears that there is no real *up* or *down*; for what is up to one country is down to another. It must seem strange to those who are ignorant of the shape of the earth, to suppose that if we could bore a hole downwards, deep enough, we should come to the other side of the world, where we should find a surface and sky like our own; yet if we reflect a moment we shall perceive that this is perfectly true. As we are preserved in our situations by the power of attraction, which draws us towards the centre of the earth, we call that direction down, which tends to the centre.

We mentioned before, that the earth has two motions; the one a diurnal motion, round its own axis; the other an annual motion, round the sun. It is the former which causes light and darkness, day and night; for when one side of the earth is turned towards the sun, it receives his rays, and is illuminated, causing day; on the contrary, when one side of the earth is turned from the sun, we are in darkness, and then we have night. We see, therefore, by how much more simple means this change is effected, than they imagined, who supposed that the earth was fixed, and that the immense globe of the sun was whirled round the earth with the amazing velocity that would be necessary.

*Twilight* is owing to the refraction of the rays of light by our atmosphere, through which they pass, and which, by bending them, occasions some to



arrive at a part of the earth that could not receive any direct rays from the sun.

It is the annual motion of the earth round the sun which occasions the diversity of *seasons*. To understand this, we must observe what has been already mentioned, that the axis of the earth is inclined to the plane of its orbit  $23\frac{1}{2}^{\circ}$ , and that it keeps always parallel to itself; that is, it is always directed to the same star.

Let Plate 24. fig. 1. represent the earth in different parts of its elliptic orbit. In the spring, the circle which separates the light from the dark side of the globe, called the *terminator*, passes through the poles *n s*, as appears in the position A. The earth then, in its diurnal rotation about its axis, has every part of its surface as long in light as in shade; therefore the days are equal to the nights all over the world, the sun being at that time vertical to the equatorial parts of the earth. As the earth proceeds in its orbit, and comes into the position B, the sun becomes vertical to those parts of the earth under the tropic, and the inhabitants of the northern hemisphere will enjoy summer on account of the solar rays falling more perpendicularly upon them; they will also have their days longer than their nights, in proportion as they are more distant from the equator; and those within the polar circle, as will be perceived by the figure, will have constant day-light. At the same time, the inhabitants of the southern hemisphere have winter, their days being shorter than their nights, in proportion as they are farther from the equator, and the inhabitants of the polar regions will have constant night.

The earth then continues its course to the position C, when the terminator again passes

through the poles, and the days and nights are equal.

After this the earth advances to the position D, at which time the inhabitants of the northern hemisphere have winter, and their days are shorter than their nights.

The positions B and D are the solstitial points; and A and C the equinoctial points; they are not equidistant from each other, because the sun is not in the centre, but in the focus of the ellipsis. In summer, when the earth is at B, the sun is farther from it than in the winter, when the earth is at D; and, in fact, the diameter of the sun appears longer in winter than in summer. The difference of heat is not owing to the sun's being nearer to us, or more remote, but to the degree of obliquity with which its rays strike any part of the earth.

The *Moon* is, next to the sun, the most remarkable of the celestial objects. Its form is spherical, like that of the earth, round which it revolves, and by which it is carried round the sun. Its orbit is also elliptical, having the earth in one of the foci of the ellipsis. The moon always keeps the same side towards us, showing only at one time a little more of one side, and at another time a little more of the other side. When the moon is viewed through a good telescope, its surface appears covered with ridges, mountains, pits, and cavities of great variety.

It was formerly supposed that the height of the lunar mountains exceeded those of our earth; but Herschel has re-measured them, and supposes that they generally do not exceed half a mile in height. He has observed some of the mountains luminous; these he supposes to be volcanoes.

Some parts of its surface also reflect less light

than the rest. It has been conjectured that the part which reflects the least light is water, and that the brightest part is land. This, however, is uncertain; and some are of opinion that the moon contains no water.

It has been doubted whether the moon has an atmosphere like ours; and notwithstanding great pains have been taken on this subject, no proofs of an atmosphere have been established.

The moon is seen by means of the light which comes to it from the sun being reflected from it. Its changes or *phases* depend upon its situation relatively to the earth and the sun. When the moon is in *opposition* to the sun, the enlightened side is turned towards the earth, and it appears full. When the moon is in *conjunction* with the sun, its dark side is turned towards us, and it is invisible. As it proceeds in its orbit, a small part of the enlightened side is seen, and then we have a *new moon*; and we continue to see more and more of the enlightened side, as the moon approaches to the state of opposition or *full moon*. The *waning* or decreasing of the moon takes place in the same manner, but in a contrary order.

The earth must perform the same office to the moon, that the moon does to us; and it will appear to the inhabitants of the moon, (if there be any,) like a very magnificent moon, being to them about fifteen times as big as the moon to us, and it will also have the same changes or phases.

The moon's motion is subject to many irregularities, on account of the inclination of its orbit to the plane of the ecliptic, and the attraction of the sun and the other planets.

*Mars* is not so bright as Venus, nor even as Jupiter, though nearer to the sun. Its colour is a

little reddish. Some spots have been observed upon its surface, from which its rotation round its axis, and the inclination of its axis to the plane of its orbit, have been determined.

*Ceres Ferdinandea* is a very small planet, situated next without Mars; it was discovered on the first day of the present century by Mr. Piazzi, an Italian astronomer.

*Pallas* is another very small planet, discovered by Dr. Olbers of Bremen, on the 28th of March, 1802.

*Harding* is the last discovered planet, so called after the first observer, M. Harding.

*Jupiter* is the brightest planet next to Venus. When viewed by a telescope, several belts are observed across its disc, parallel to its equator: these belts are supposed to be ranges of clouds in the atmosphere of the planet. Jupiter is surrounded by four moons of different sizes, which move about in different times. These moons are sometimes eclipsed by the shadow of Jupiter falling upon them. These eclipses have been found of great use in determining the longitudes of places.

*Saturn* can hardly be seen by the naked eye. When examined by a telescope, it exhibits a very remarkable appearance. It is surrounded by a thin, flat, broad luminous ring, which surrounds the body of the planet, but does not touch it. This ring casts a strong shadow upon the planet, and appears to be divided into two, by a distinct line in the middle of its breadth. This ring is circular, but appears elliptical from its being viewed obliquely. Besides this ring, Saturn has seven moons of different sizes, and its body is surrounded also by belts, like those of Jupiter.

*The Georgium Sidus*, with its six satellites, have

been entirely discovered by Herschel. It cannot be seen without a telescope, but it does not require a powerful one. The satellites cannot be seen without the most powerful telescopes.

### *Comets.*

Besides these planets already mentioned, there are some other bodies which revolve round the sun, called *comets*. They move in very eccentric ellipses, and their periods of revolution are so long, and imperfectly known, that few are ever observed twice. They are only seen by us when they are in that part of their orbit which is nearest to the sun, and then they move so fast, they soon become again invisible to us. The number of comets is also unknown; numbers of small ones have been discovered by telescopes. Their distances are inconceivably great, and most of them move entirely beyond the planetary orbits; though some have descended below Mars. Their appearances are very different. Some resemble only a faint vapour; others have a nucleus or solid part in the middle. When they approach the sun, they put forth the appearance of a beard or tail of luminous matter, which is sometimes of astonishing length. These tails are always directed from the sun.

With respect to the real nature and use of the comets in the system, we are entirely unacquainted.

### *Fixed Stars.*

The fixed stars are so called, because they are observed not to change their places in the heavens,

as the planets do. They appear of an infinite variety of sizes; yet, for convenience, it is usual to class them into six or seven magnitudes: thus, they are called stars of the first, second, &c. magnitude. To the naked eye they appear innumerable; but this is only the consequence of their being scattered in so confused a manner, and our not being able to see them all at one view. The whole number of stars visible to the naked eye is about 3186. But seldom above one-third of that number can be seen by most people. From the earliest ages they have been divided into groups, or constellations, which have been called by the names of various animals and objects, from a supposed resemblance to them: such as the Great Bear, the Little Bear, the Swan, &c.

The fixed stars are placed at a distance from us so great, that it cannot be ascertained by any means yet known; hence, they must shine by their own light, and not by the light which they receive from our sun, as the planets do. Though it has been formerly mentioned that the relative situations of the fixed stars do not vary, yet, in the course of several ages, some variations have been observed among them. Some of the larger stars have not the same precise situations that ancient observations attribute to them, and new stars have appeared, while some others which have been described, are now no longer to be found. Some stars are likewise found to have a periodical increase and decrease. Others of the fixed stars, upon examination with the telescope, are found to consist of two.

Besides the phenomena already mentioned, there are many luminous spots like faint bright clouds, which are always seen in the same relative situation. These spots are called *nebulae*. When examined

with a good telescope, they are resolvable into clusters of innumerable stars, and with the glass many nebulæ are discovered, which cannot be seen by the naked eye.

Herschel has rendered it highly probable, both from observation and well-grounded conjecture, that the starry heavens is replete with these nebulæ, or system of stars, and that the *milky way* is that particular nebula in which our sun is placed. Reasoning analogically from the circumstances with which we are acquainted, we may deduce, that the universe consists of nebulæ or distinct systems of stars: that each nebula is composed of a prodigious number of suns, or bodies that shine by their own native splendour; and that each individual sun is, perhaps, destined to give light to numbers of worlds that revolve about it.

What an august, what an amazing conception does this give of the works of the Creator! Instead of one world and one sun, we find thousands and thousands of suns, ranged around us at immense distances, attended by innumerable worlds all in rapid motion, yet calm, regular, and harmonious, invariably keeping the paths prescribed them; and these worlds, perhaps, peopled with myriads of intelligent beings, formed for endless progression in perfection and felicity!

### *Of Eclipses.*

When any one of the heavenly bodies is obscured or darkened by the shadow of another falling upon it, or by the interposition of any body, it is said to be *eclipsed*.

The eclipses of the sun and moon are the most striking. They were formerly considered as ominous, and have often excited the dread and apprehension of the vulgar ; but the improvement of science has shown, that they have no connexion with future events ; that they depend upon regular and invariable causes, and may be calculated and foretold with the greatest certainty.

As the earth is an opaque body, enlightened only by the sun, it will cast a shadow towards that side which is farthest from the sun. If the sun and earth were of the same size, this shadow would be cylindrical, and would extend to an infinite distance ; but as the sun is much larger than the earth, the shadow of the latter must be conical, and end in a point (Plate 24. Fig. 2). On the sides of this conical shadow, there is a diverging shadow, the density of which decreases in proportion as it recedes from the sides of the former conical shadow : this is called the *penumbra*. As the moon revolves round the earth, sufficiently near to pass through the shadow of the earth, an eclipse must always take place when these three are all in one straight line. An eclipse of the moon can never happen but at the time of full moon ; but on account of the inclination of the moon's orbit to that of the earth, an eclipse cannot take place every full moon. When the moon passes entirely through the earth's shadow, the eclipse is *total* ; but when only a part of it passes through the shadow, the eclipse is *partial*. The quantity of the moon's disc which is eclipsed (and the same thing is to be understood of that of the sun, in a solar eclipse), is expressed by twelve parts called *digits* : that is, the disc is supposed to be divided by 12 parallel lines ; then if half the



disc is eclipsed, the quantity of the eclipse is said to be six digits. When the diameter of the shadow through which the moon must pass, is greater than the diameter of the moon, the quantity of the eclipse is said to be more than 12 digits; thus if the diameter of the moon is to that of the shadow as four to five, then the eclipse is said to be 15 digits. The duration of a lunar eclipse is various, but never exceeds two hours.

The eclipses of the sun are owing to a different cause than those of the moon. They are occasioned by the moon's coming directly between us and the sun, and, therefore, obstructing our view of it. When the moon happens to be in conjunction with the sun, or between the sun and the earth, viz. at the time of the new moons, the shadow of the moon falls upon the surface of the earth; hence, properly speaking, such eclipses should be called eclipses of the earth. But the whole disc of the earth cannot be involved in the shadow of the moon, because the moon is much smaller than the earth, and the shadow of the moon is conical. Thus, in Plate 24. Fig. 3., the rays of the sun S, being intercepted by the moon L, form the conical shadow C D G, which falling upon the surface of the earth, entirely deprives the portion of it upon which it falls, of the sun's light, and, of course, the inhabitants of that part of the earth will have a total eclipse of the sun. Beyond the dense conical shadow C D G, there is a diverging half shadow, or *penumbra*, C D E F, which is occasioned by the moon's intercepting only a part of the sun's rays from those places which fall within this penumbral cone, and are out of the dense shadow. Thus from the part of the earth Z, the portion Y Y B, of the sun only can be seen; con-

sequently, the inhabitants of that part will have a partial eclipse.

As the moon is not always at the same distance from the earth, it sometimes happens that the conical dense shadow does not reach the earth, as in Plate 24. Fig. 4., and only the penumbral shadow falls upon it; this eclipse, consequently, is partial to every part of the earth. Those who are at the centre of the penumbra will lose sight of the centre of the sun, by the interposition of the moon's body, which subtending a smaller angle than the sun, will not entirely cover its surface: so that there will be a ring of light. The eclipse is then said to be *annular*.

The satellites, or moons, are often eclipsed by the planets to which they belong. The eclipses of Jupiter's moons are observed with great attention, as they are very useful in ascertaining the longitude.

When any of the planetary bodies disappear by another coming before it, it is called an *occultation*. The occultations of the fixed stars by the moon are of great use in determining the longitudes of places.

### *Of the Tides.*

The ebbing and flowing of the sea were first shown by Kepler to be owing to the moon's attraction: and Newton demonstrated it upon the principles of gravitation. The attraction of the moon cannot alter the shape of the solid of the globe, but it has a considerable effect upon the fluid part, which it causes to assume a spheroidal figure, the longest axis being in the direction of the moon. It is, therefore, the highest tide at that place perpen-

dicularly under the moon, or where the moon crosses the meridian.

The sun also has some action upon the waters, though its attraction, on account of its distance, is not so strong as that of the moon. When the action of the sun and moon conspire together, the tide rises higher, and produces what are called *spring tides*. On the contrary, when they counteract each other, they produce *neap tides*.

## RECAPITULATION

OF

THE PRINCIPAL DEFINITIONS AND FACTS IN THE  
SEVERAL DIVISIONS OF THIS VOLUME.

---

ABSTRACT OF MECHANICS.

### *Of Matter.*

1. ALL substance, or matter, has the properties of solidity, or impenetrability, divisibility, mobility, and inertia.
2. All bodies appear to possess also attraction and repulsion.
3. *Solidity* is that property by which two bodies cannot occupy the same place at the same time.
4. *Divisibility* is that property by which bodies are capable of being divided into parts.
5. *Mobility* is the property of being capable of receiving motion when imparted to it.
6. *Inertia* is the tendency which bodies have to continue in the state into which they are put, whether of rest or motion.

### *Space.*

1. Space is either absolute or relative.
2. *Absolute space* is mere extension; it has no limits or bounds, and is itself immovable.

3. *Relative space*, is that part of absolute space which is occupied by any body, and is compared with any part occupied by another body.

### *Motion.*

1. Motion is also either *absolute* or *relative*.

2. *Absolute motion* is the actual motion that bodies have, independent of each other, and only with regard to the parts of space.

3. *Relative motion* is the degree and direction of the motion of one body, when compared with that of another.

4. *Accelerated motion* is when the velocity of the motion continually increases.

5. *Retarded motion* is when the velocity continually decreases.

6. The *velocity* of uniform motion is estimated by the time employed in moving over a certain space; or by the space moved over in a certain time.

7. To ascertain the velocity, divide the space run over by the time.

8. To know the space run over, multiply the velocity by the time.

9. In accelerated motion, the space run over is as the *square* of the time, instead of being directly as the time, as in uniform motion.

10. A body acted upon by only one force, must always move in a straight line.

11. Bodies acted upon by two uniform forces, whether equal or unequal, must also describe a straight line.

12. But if a body be acted upon by one uniform force, or single impulse, and another accelerating

force in a different direction, these two forces together will cause it to describe a *curve*.

13. The curve described by a ball projected from a cannon, and brought to the earth by the action of gravity, is that of a *parabola*.

14. The *momentum* of a body is the *force* with which it moves, and is in proportion to the weight or quantity of matter multiplied into its velocity.

### *Attraction and Repulsion.*

1. The causes of these powers are totally unknown.

2. There are various kinds of attraction—the attraction of *cohesion*, of *gravitation*, of *electricity*, *magnetism*, and *chemical attractions*.

3. The attraction of cohesion acts only at very small distances.

4. The attraction of gravitation is that which masses of matter exert on each other at all distances.

5. Gravitation decreases from the surface of the earth upwards, as the square of the distance increases.

### *Central Forces.*

1. The central forces are the *centrifugal* and the *centripetal* force.

2. The centrifugal force is the tendency which bodies that revolve round a centre have to fly off from it in a tangent to the curve they move in—as a stone from a sling.

3. The centripetal force is that which prevents its flying off, by impelling it towards the centre—as the attraction of gravitation.

*Centre of Gravity.*

1. The *centre of gravity* is that point in which the weight of a body may be supposed to be collected.

2. A line drawn from that point, perpendicular to the horizon, is called the *line of direction*.

3. When the line of direction falls within the base of any body, that body will stand ; but when it falls without the base, the body will fall.

*The Lever.*

1. There are three kinds of levers: 1. When the fulcrum, or prop, is between the power and the weight. 2. When the prop is at one end of the lever, the power at the other, and the weight between them. 3. When the prop is at one end, the weight at the other, and the power between.

2. In all kinds of levers, the power is to the weight, as the distance of the weight from the fulcrum is to that of the power from the fulcrum.

3. A *bent*, or *hammer lever*, differs only in form from a lever of the first kind.

4. A *balance* is also a lever of the first kind, with equal arms.

5. The *statera*, or *steel-yard*, is also the first kind of lever, with a moveable weight.

*Wheel and Axle.*

1. The power must be to the weight, in order to have an equilibrium, as the *circumference* of the wheel to the *circumference* of the axle.

2. As the diameters of circles are in proportion to their circumferences, the power is to the weight also as the *diameters*.

3. If one wheel move another of equal circumference, they will both move equally fast.

4. But if a wheel move another of different diameter, whether larger or smaller, the velocities with which they move will be inversely as their diameters, circumferences, or number of teeth.

### *Pulley.*

1. Pullies are of two kinds, *fixed* and *moveable*.

2. In the *fixed* pulley, when the power and weight are equal, they balance each other, and no mechanical advantage is obtained.

3. In the *moveable* pulley, the power need only to be equal to half the weight, to balance.

### *Inclined Plane.*

That the power and weight may balance each other, the former must be to the latter as the height of the plane to the length.

### *Wedge.*

1. When the resistance acts perpendicularly to the sides, the power will be to the weight as half the thickness of the wedge on the back is to the length of the sides.

2. When the resistance acts parallel to the back, the power is to the resistance as the whole length of the back to that of the sides.



*Screw.*

1. A screw may be considered as an inclined plane.

2. It is always used with a lever; and the power is to the weight, as the distance from one thread, or spiral, to another, is to the circumference of the circle described by the power.

3. When a screw acts in a wheel, it is called an *endless screw*.

*Compound Machines.*

1. In all machines, simple as well as compound, what is gained in power is lost in time.

2. In any machine, the power is to the weight, when in equilibrio, in a proportion formed by the multiplication of the several proportions which the power bears to the weight, in every simple mechanical power used in the machine.

3. The power of a machine is not at all altered by varying the sizes of the wheels, provided this proportion produced at last by the multiplication of the power of each several part, remain the same.

*Moving powers in Machinery.*

1. A horse exerts more strength when drawing horizontally; but the line of draught should not be level with his breast, but incline upwards, making a small angle with the horizontal plane.

2. When a horse works in a circle, it should not be less than forty feet in diameter.

3. In turning a winch, a man exerts his strength in different proportions at different parts of the

circle. The greatest force is when he pulls the handle upwards from the height of the knee; and the least where he thrusts from him horizontally.

### *Friction.*

1. Friction is owing to the roughness of bodies.
2. It increases according to the weight and velocity of moving bodies, and also according to the surface, though in a small degree.

### *Communication of Motion in Machines.*

Motion is communicated from one part of a machine to another by various methods; by levers, cords, wheels, &c. and wheels move each other by the simple contact of their surfaces when pressed together, or by teeth. The proper shape of the teeth is an object of great importance.

### *Fly Wheels.*

1. Fly wheels are employed to *equalize* the motion of a machine.
2. A fly cannot in any other way *add* power to the machine.

### *Mills.*

1. Water-mills are of three kinds—*undershot mills*, *breast-mills*, and *overshot-mills*. The powers necessary to produce the same effect on each of these, must be as the numbers, 2.4, 1.75, and 1.
2. But as a fall of water cannot be always had, the *undershot-mills* are often used.

3. *Bevelled-wheels* are much used for changing the direction of motion in wheel-work.

4. Hook's *universal joint* is sometimes used for the same purpose.

5. The ends of the teeth of wheels ought never to be circular, but formed of parts of an *epicycloid*.

### *Pendulums.*

1. All the vibrations of the same pendulum, whether great or small, are performed in equal times.

2. The longer a pendulum, the slower are its vibrations.

3. Heat expands, and consequently lengthens, pendulums; and cold contracts, and shortens them.

4. A pendulum, to vibrate seconds, must be shorter at the equator than at the poles.

5. Methods have been used for correcting the irregularity arising from expansion and contraction: one of these is the *gridiron-pendulum*.

6. *Deal* is the best substance for pendulum-rods, as it is very little affected by heat and cold.

### *Chronometers.*

1. Chronometers are instruments for measuring time.

2. Clocks are moved either by a weight or a spring. Watches differ from the latter only in being portable.

3. The pendulum in a clock, and the balance in a watch, are the parts which properly measure time by their vibrations.

*Wheel-Carriages.*

1. Wheels of carriages turn round, on account of the friction they sustain in contact with the roads.

2. Large wheels, in general, are more advantageous than small ones.

3. In four-wheeled carriages, the fore-wheels are made smaller than the hind ones, for the convenience of turning; otherwise they would be better of the same size.

4. *Broad wheels* are better for heavy carriages—such as waggons—because they press and harden, instead of cutting up the roads as small wheels do.

## ABSTRACT OF HYDROSTATICS.

1. Hydrostatics treat of the *mechanical* properties of *non-elastic* fluids, such as water.

2. The *cause* of fluidity is not perfectly known; but it cannot be owing to any particular configuration of particles, since fluids and solids are convertible into each other by adding or subtracting heat.

3. A portion of fluid gravitates in another, when surrounded by a larger portion, in the same way as if it were in the air.

4. Fluids press *in all directions* equally.

5. A fluid presses in proportion to its perpendicular height, and the base of the vessel containing it, without any regard to the quantity.

6. By *specific gravities*, is meant the relative weights of equal bulks of different substances.

7. This relative weight is generally compared with an equal bulk of *water* as a standard.

8. The instrument for comparing these weights of solids is called the *hydrostatic balance*.

9. That for comparing the specific gravities of liquids is called the *hydrometer*.

10. *Air-balloons* rise in the atmosphere, because they are *specifically* lighter, or lighter than an equal bulk, of air.

11. They are of two kinds — *fire-balloons*, and *inflammable-air* balloons.

12. The *diving-bell* is an empty vessel inverted, and made so heavy as to sink in water.

#### ABSTRACT OF PNEUMATICS.

1. *Pneumatics* treat of the *mechanical* properties of air.

2. *Air* is a solid and material substance, as well as water and other fluids.

3. Its *invisibility* is owing to its *transparency*.

4. It possesses *weight*, *compressibility*, and *elasticity*.

5. Its *weight* is demonstrated by experiment.

6. Its density and elasticity are in proportion to the force that compresses it.

7. The density of the atmosphere diminishes upwards: and if altitudes in the air be taken in arithmetical proportion, the variety of the air will be in geometrical progression.

8. Air-pumps are machines for exhausting the air from vessels.

9. A vacuum is a space emptied of air.

10. Animals cannot live, nor will a candle burn, in a vessel exhausted of air.

11. The air presses upon every body immersed in it, and on every side.

12. The rise of water in *pumps* is owing to the air on one part of the water being removed, which causes it to yield and be pressed upwards in that part.

13. *Suction* is an absurd notion, now exploded, and accounted for from the pressure of the air.

14. *Barometers* are instruments for measuring the weight or pressure of the atmosphere.

15. The *Torricellian vacuum* is the empty space in the upper part of a barometer tube.

16. Air may be *condensed*, or made to occupy less space.

17. The machines used for this purpose are called *condensers*.

18. Air in motion constitutes *wind*.

19. Machines for measuring the force of the wind are called *wind-gages*.

20. *Sound* is a vibratory motion of the air.

21. An *echo* is the *reflection* of a sound.

#### ABSTRACT OF HYDRAULICS.

1. *Hydraulics* teaches the laws of fluids in *motion*.

2. The *velocity* of spouting fluids is as the square root of the depth of the orifice below the surface.

3. Water in bended pipes always rises as high as the *source* from whence it springs: hence the construction of jets, or fountains, and the supplying of towns with water.

4. A *siphon* is a bended pipe of unequal legs. The cause of its action in emptying vessels is owing to the pressure of the atmosphere added to the preponderance of weight in the longest leg.

5. *Pumps* for raising water are of three kinds: the *sucking*, *forcing*, and *lifting-pump*.

6. The water in a sucking-pump is raised from the well by the *pressure of the atmosphere*; and it can be raised by this means only 33 feet.

7. A *lifting-pump*, not depending upon this, may raise the water to any height, according to the power applied.

8. A *forcing-pump* is also unlimited, in regard to the height to which it may raise water.

9. An *air-vessel* is added to a forcing-pump, to give a more *equable stream*.

10. A constant stream is also produced by *two* barrels, with pistons moving up and down alternately.

11. The *chain-pump* also produces the same effect, and has very little friction.

12. Buchanan's *pump* is superior to the chain-pump, and is one of the best yet invented.

13. There are many contrivances to avoid friction in pumps; but in great works, the friction of the piston is of little importance.

14. *Plungers* are pistons that nearly fill the working-barrel: these do not act upon the principle of the pressure of the atmosphere.

15. Valves in pumps are of various constructions: the most usual and best are the *clack-valve*, the *button* and *tail-valve*, the *conical-valve*, and the *globular-valve*.

16. It is immaterial whether a pump be placed perpendicular to the well or not, provided it have a communication with it by pipes.

17. In pump-work, all contractions, or sudden enlargements, in the pipes, should be avoided.

18. The steam engine was originally invented by the Marquis of Worcester, but was first put in practice to any extent, by Captain Savary.

19. Savary's engine had no lever, but acted by the immediate pressure of the steam upon the water.

20. Newcomen improved it, by adding a lever, or beam, and attaching to it a piston which worked in a cylinder. Upon this piston the pressure of the atmosphere is made to act, by forming a vacuum underneath it.

21. Mr. Watt improved the cylinder, by surrounding it with bad conductors of heat; and this prevented a waste of steam, by cooling.— He also condensed the steam, to form the vacuum under the piston, in a separate vessel. Instead of depressing the piston by the pressure of the atmosphere, he used the force of steam introduced above it, while the piston was raised up again by the load at the other end of the beam. His last improvement is the *double steam-engine*; in which the piston is forced both up and down, by the immediate pressure of the steam.

#### ABSTRACT OF ACOUSTICS.

1. The science which treats of sound is called *Acoustics*.

2. Sound is occasioned by the vibrations of the air striking upon the tympanum, or drum of the ear

3. Without air there would be no sound.

4. Echos are owing to the reflection of the waves or vibrations of the air by solid bodies.



## ABSTRACT OF OPTICS.

1. The particles of light, which are inconceivably small, proceed in straight lines from the luminous body.

2. Consequently, the density of light is inversely as the square of the distance from the luminous centre.

3. Light moves at the rate of 150,000 miles in a second.

4. When light strikes upon a surface, it is reflected so that the angle of reflection is equal to the angle of incidence: on this the properties of mirrors depend.

5. Convex mirrors cause parallel rays to diverge.

6. Concave mirrors collect parallel rays, or cause them to converge to a point called the focus.

7. When light passes out of one medium into another, it changes its direction, and either moves farther from, or nearer to, the perpendicular, as the medium into which it enters is rarer or denser than the other medium. The properties of lenses are derived from this law.

8. Convex lenses collect the rays of light, or make them converge to a focus.

9. Concave lenses disperse the rays of light.

10. Light is composed of seven primitive colours, which have not yet been decomposed. But in the practice of painting, all the various tints may be made of three colours, blue, red, and yellow.

11. The rainbow is owing to the separation of the rays of light into its original primitive colours, by the drops of falling rain.

12. The human eye is an optical instrument, resembling a camera obscura.

13. Microscopes are instruments for viewing very small objects. They apparently magnify objects, because they enable us to see them nearer, without destroying distinctness of vision.

14. Telescopes are instruments for viewing objects at a great distance.

15. Acromatic telescopes are such as have glasses so contrived, as to correct the unequal refraction of the rays of light.

Before we conclude the subject of optics, we shall mention an improvement in spectacle-glasses, by Dr. Wollaston.

Supposing an eye to be placed in the centre of any hollow globe of glass, it is plain that the objects would then be seen *perpendicularly* through its surface in every direction; consequently, the more nearly any spectacle-glass can be made to surround the eye, in the manner of a globular surface, the more nearly will every part of it be at *right angles* to the line of sight, the more uniform will be the power of its different parts, and the more completely will the indistinctness of lateral objects be avoided.

According to this principle, it appears that all spectacle-glasses should be convex on their exterior surface, and concave within. The section of those for long-sighted persons will assume the form of a meniscus, or crescent (Plate 17. fig. 3.); and those adapted for short sight, will have their principal curvature on the concave side (Plate 17. fig. 4.) These glasses are called *perisopic spectacles*, from their affording the opportunity of *looking round*.

## ABSTRACT OF ELECTRICITY.

1. Electricity is supposed to be a fluid, which pervades *all substances*, and when undisturbed, remains in a state of equilibrium.

2. The portion which every body is supposed to contain is called its *natural share*.

3. When a body is by any means possessed of more or less than its natural share, it is said to be *electrified*, or *charged*.

4. If it possesses more than its natural quantity, it is said to be *positively* electrified; if it contain less than its natural share, it is said to be *negatively* electrified.

5. Bodies through which the electric fluid passes freely are called *conductors*, or *non-electrics*. Those bodies which oppose the passage of electricity, are called *non-conductors*, or *electrics*.

6. The equilibrium of the electric fluid is disturbed by the friction of bodies against each other, and electricity is then said to be *produced*, or *excited*.

7. Electricity is excited in the *greatest quantity*, by the friction of *conductors* and *non-conductors* against each other.

8. Two bodies, both *positively*, or both *negatively* electrified, *repel* each other; whereas, if one body be *positive*, and the other *negative*, they will *attract* each other.

9. Upon this principle *electrometers*, or instruments for ascertaining the degree in which a body is electrified, are constructed.

10. If a body, containing only its natural share of electricity, be presented sufficiently near to a body electrified, *positively* or *negatively*, a quantity

of electricity will force its way through the air, from the latter to the former, appearing in the form of a *spark*.

11. When two bodies approach each other sufficiently near, one of which is electrified *positively*, and the other *negatively*, the superabundant electricity rushes violently from one to the other, to restore the equilibrium between them. This effect takes place, if the two bodies be connected by a conducting substance.

12. If an animal be placed so as to form part of this circuit, the electricity, in passing through it, produces a sudden effect upon it, which is called the *electric shock*.

13. The motion of electricity, in passing from a positive to a negative body, is so rapid, that it appears to be *instantaneous*.

14. When any part of one side of a piece of glass is presented to a body electrified positively or negatively, that side becomes possessed of the *contrary* electricity to the side of the body it is presented to; and the other side of the glass is possessed of the *same* kind of electricity as the other body.

15. This electricity communicated to the glass *does not spread*, but is confined *to the part* where it is communicated, on account of the non-conducting quality of the glass.

16. To accelerate the communication, and to enable it to be applied to the whole surface, the glass is covered with tin-foil, which is called *coating* the glass.

17. If a conducting communication be made between both of the sides of a glass so *coated* and *charged* with electricity, a *discharge* takes place.

18. It is immaterial whether the glass be flat, or in any other form ; on account of convenience, cylindrical jars are used for this purpose.

19. A vessel of this kind is called a *Leyden phial*, from the place where this property was first discovered.

20. When many of these phials, or jars, are connected together, it is called an *electrical battery*.

21. Electricity is capable of producing the most powerful effects, oxidating gold and silver, and firing inflammable substances.

22. *Metallic points* attract the electricity from bodies, and discharge them *silently*. This property has rendered them useful in defending buildings from lightning.

23. When electricity *enters* a point, it appears in the form of a *star* ; when it *issues* from a point, it puts on the appearance of a *brush*, or *pencil*.

24. *Models* may be put in motion by the electric fluid which issues from a point.

25. *Lightning* appears to be the rapid motion of vast masses of electric matter.

26. Thunder is the noise produced by the motion of lightning. When electricity passes through highly rarefied air, it constitutes the *aurora borealis*.

27. Many of the great convulsions of Nature, such as earthquakes, hurricanes, whirlwinds, are generally accompanied by electrical phenomena.

#### ABSTRACT OF GALVANISM.

1. Galvanism is so called from Galvani, an Italian, who first discovered it.

2. It appears to be only another mode of exciting electricity.

3. Galvanic electricity is produced by the chemical action of bodies upon each other.

4. The oxydation of metals appears to produce it in great quantities. Electricity produced by this means appears to be in a state of less condensation, than when it is produced by friction, as in an electrical machine.

5. Galvanic electricity can be made to set on fire inflammable substances, oxydate metals, and charge a Leyden phial, nearly in the same manner as common electricity.

6. The nerves of animals appear to be most easily affected by it, of any known substances.

7. Galvanic electricity is conducted, and refused a passage, by the same substances as common electricity.

8. When it is made to pass through an animal, it produces a sensation resembling the electrical shock.

9. The electricity produced by animals, as the torpedo and electrical eel, are analogous to galvanism.

#### ABSTRACT OF MAGNETISM.

1. The cause of magnetism is totally unknown; some have attributed it to a peculiar fluid, which they have called the magnetic fluid.

2. Iron is the only known body that is capable of being possessed of magnetism.

3. Every magnet has two opposite points, which are called *poles*.

4. When a magnet is left at liberty to move freely, it places itself so that these poles point nearly north and south. This is called the *directive property*, or *polarity* of the magnet.

5. When two magnets approach each other, their poles of the *same names*, that is, both their north poles, or both their south poles, *repel* each other

6. But poles of *different* names *attract* each other.

7. The earth itself appears to be a great magnet, having its poles near to, but not coinciding with the ends of the imaginary axis, on which it turns.

8. Its poles act upon every small magnet attracting its contrary pole.

9. From this theory the *dip*, or *inclination* of a magnet to the plane of the horizon is easily explained.

10. The deviation of the direction of a magnet from due north and south, is owing to the situation of the magnetic poles of the earth, and is called the *declination* of the magnet.

11. The magnetic poles of the earth are not stationary, but are continually changing their places.

12. This occasions a constant change of the declination, and this is called the *variation of the compass*.

13. The loadstone is an iron ore naturally possessing magnetism.

14. Magnetism may be communicated to iron and steel.

15. Pure iron most easily receives magnetism, but loses it immediately.

16. Iron combined with carbon, as hard iron or steel, retains the magnetic properties when communicated to it.

17. A steel bar rendered magnetic, and fitted

up in a box, so as to move freely in every direction, constitutes the *mariner's compass*.

---

#### ABSTRACT OF ASTRONOMY.

1. The fixed stars are probably suns at immense distances : and *our sun* is only a fixed star much nearer to us, forming the centre of our system.

2. There are nine *primary*, and eighteen *secondary* planets moving round the sun.

3. The *moon* is a secondary planet moving round the earth.

4. All these planets move in orbits which are nearly circular, but in reality are *elliptical*, having the sun in one focus.

5. They are preserved in their orbits by the power of *attraction* and the *centrifugal force*, which exactly balance each other.

6. The *comets* are probably a species of planets, moving in very eccentric orbits. Some of them come very near the sun; and they must go to immense distances from him, as some of their periods are very long, and but few are known to return. With their nature we are not acquainted.

7. The planets revolve round an imaginary axis, in various periods of time, which constitute the *day* and *night* of each planet.

8. The time of the revolution of each planet round the sun forms its *year*.

9. Their axes are inclined to the planes of their orbits, which occasions the *diversity of seasons*.

10. Eclipses of the sun are occasioned by the moon coming between the earth and the sun, and thus covering his disc.



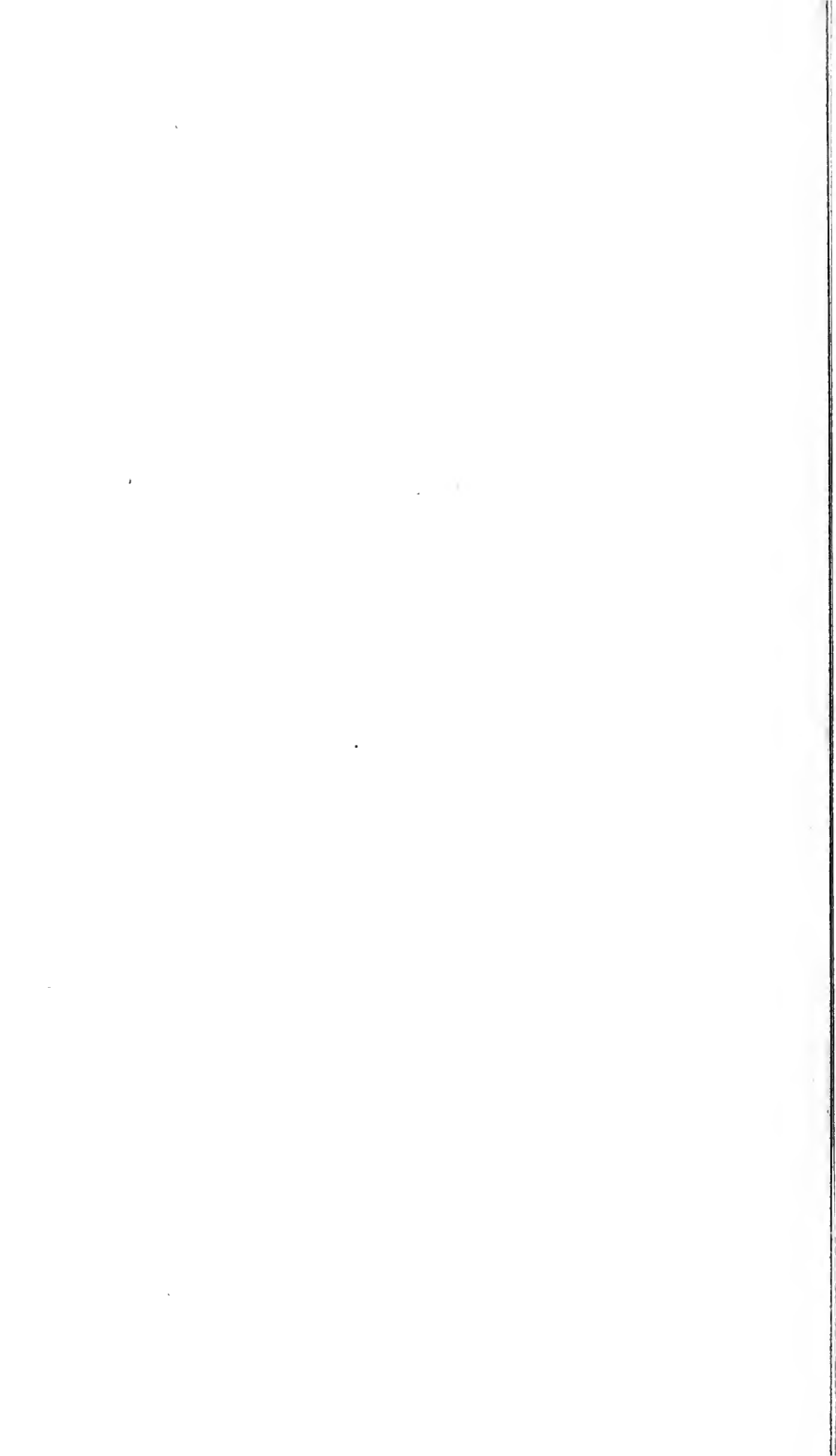
11. Eclipses of the moon are owing to the shadow of the earth falling upon the moon.

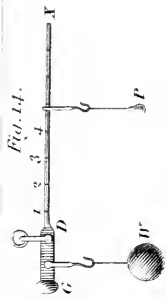
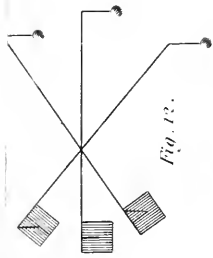
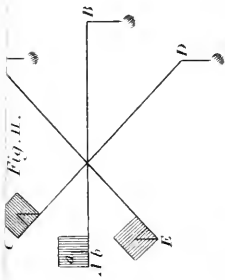
12. The eclipses of the other satellites are caused by their coming into the shadows of their respective primaries.

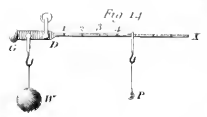
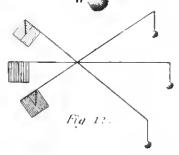
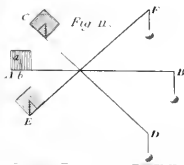
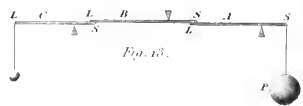
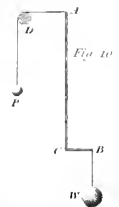
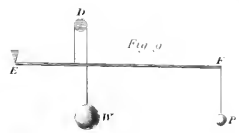
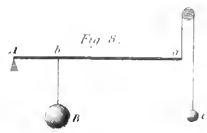
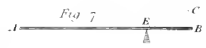
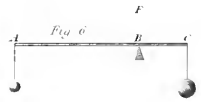
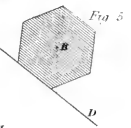
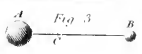
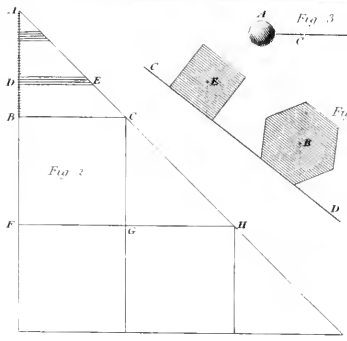
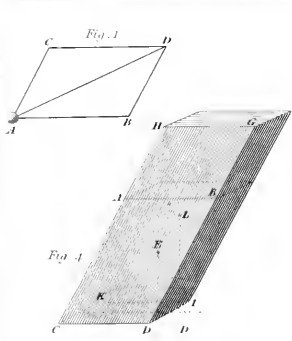
13. The tides are owing to the effect of the attraction of the moon and sun upon the waters of the sea. When the sun and moon act together, they occasion *spring tides*; when they counteract each other's attraction, *neap tides* take place.

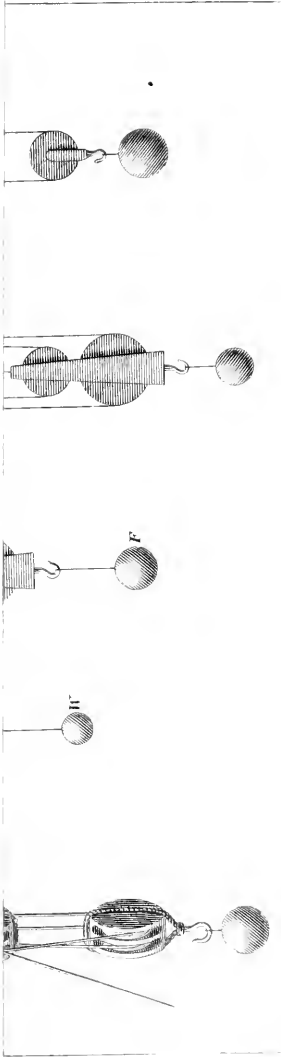
END OF THE FIRST VOLUME.

LONDON:  
Printed by A. & R. Spottiswoode,  
New-Street-Square.

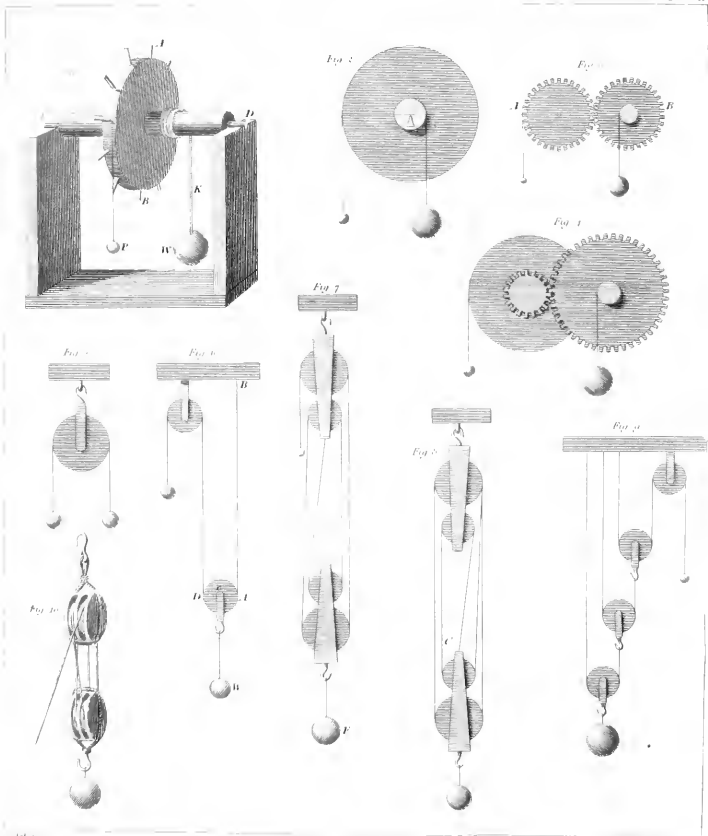






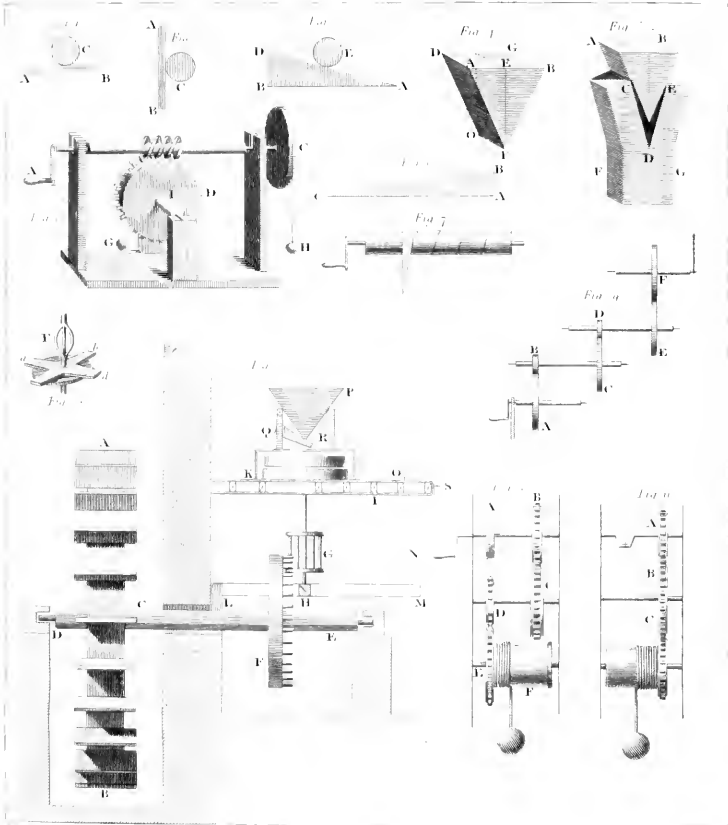


T. Weber's Pat.

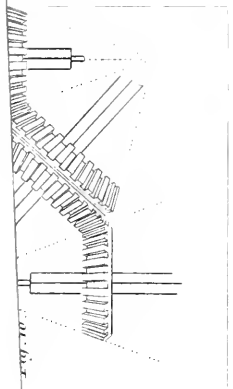
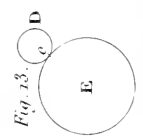
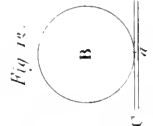




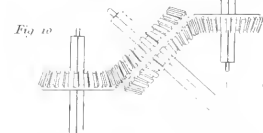
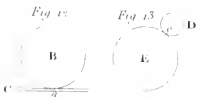
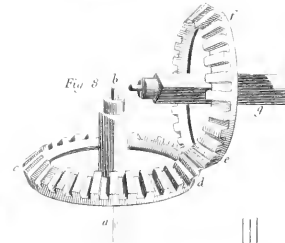
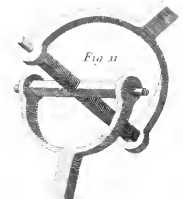
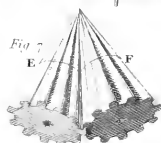
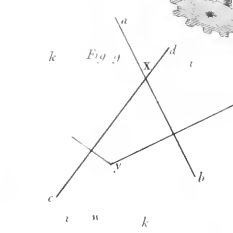
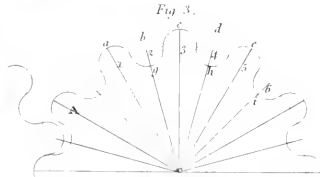
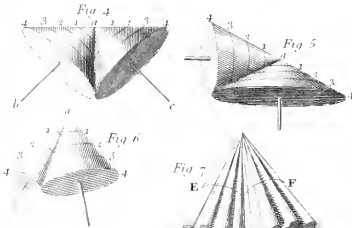
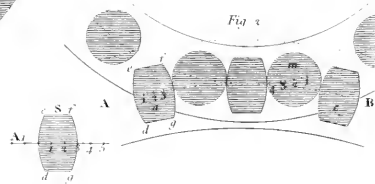
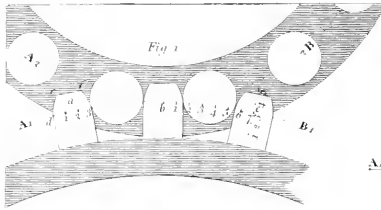
*Fig. 100. del.*

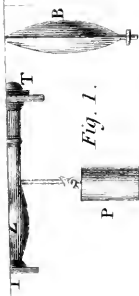




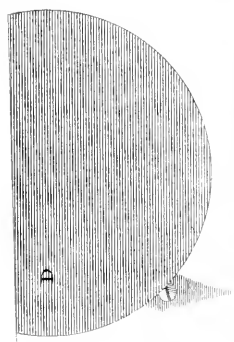
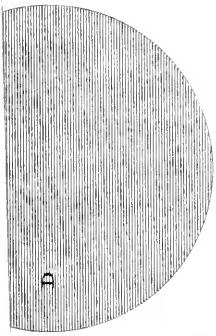


T. Webster del.





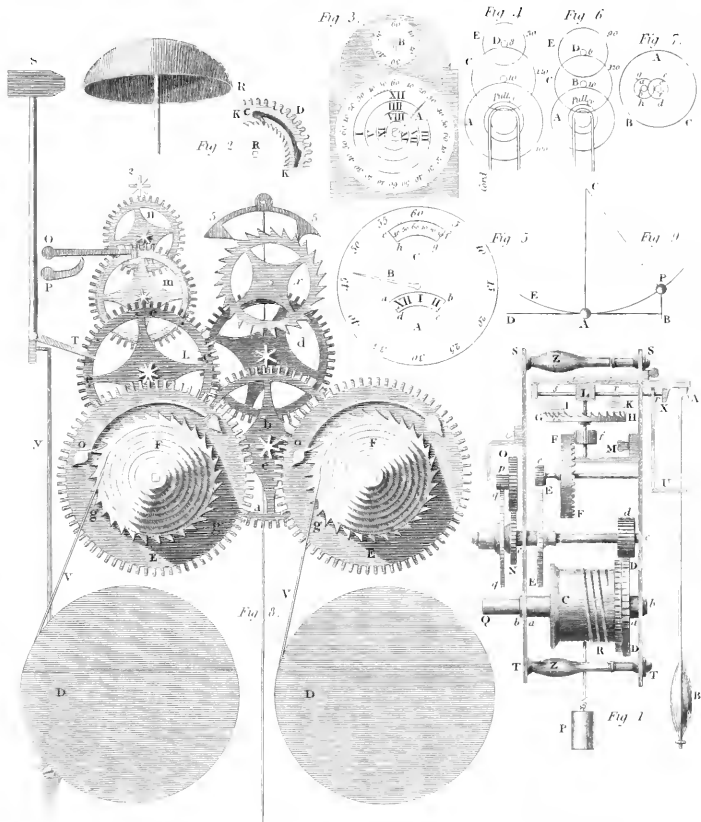
*Fig. 1.*

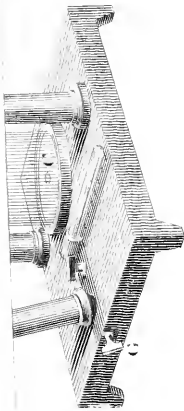
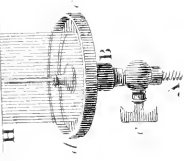
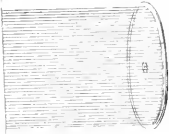
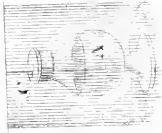


*Fig. 2.*

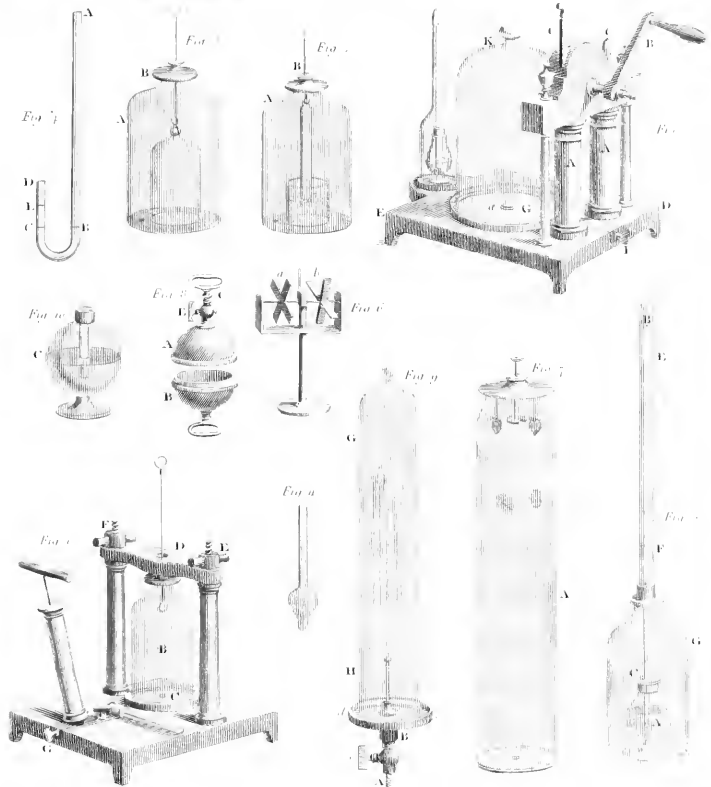
CLOCK WORK

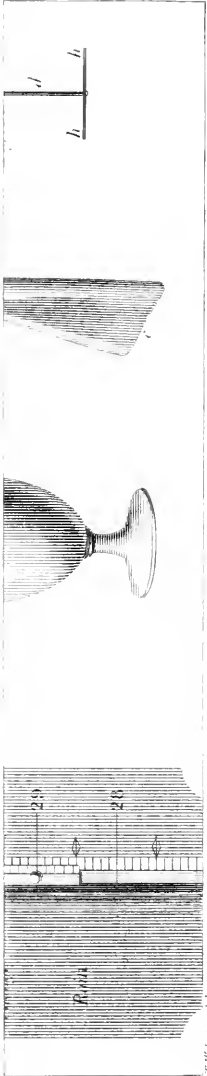
Plat.





*Patent*

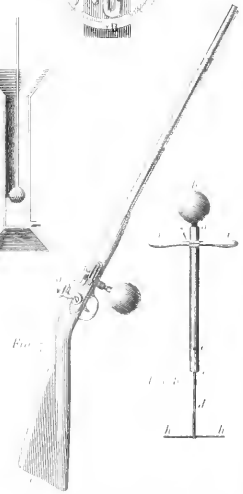
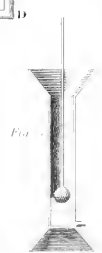
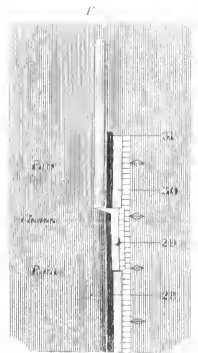
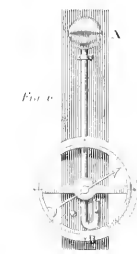
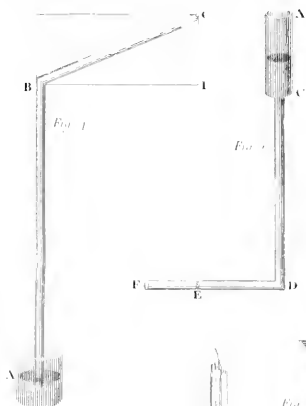




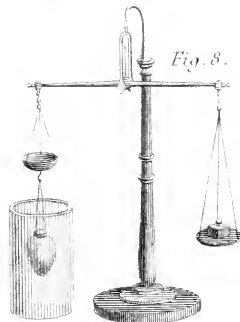
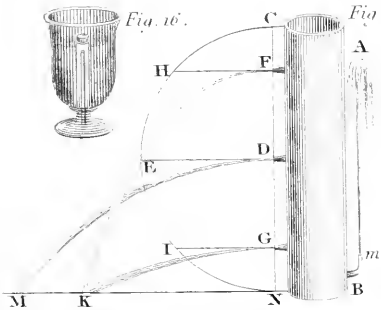
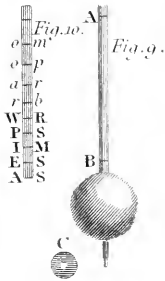
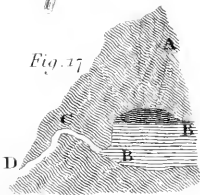
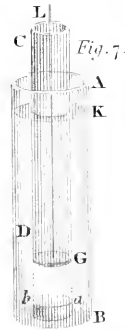
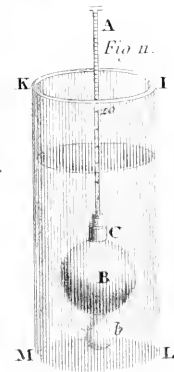
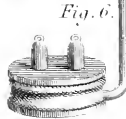
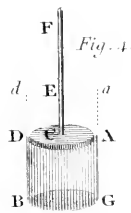
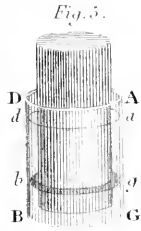
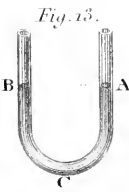
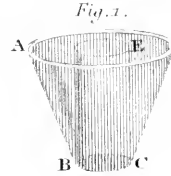
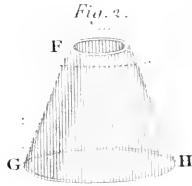
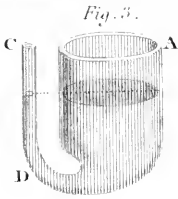
*T. H. G. G. G. G. G.*

PNEUMATICS.

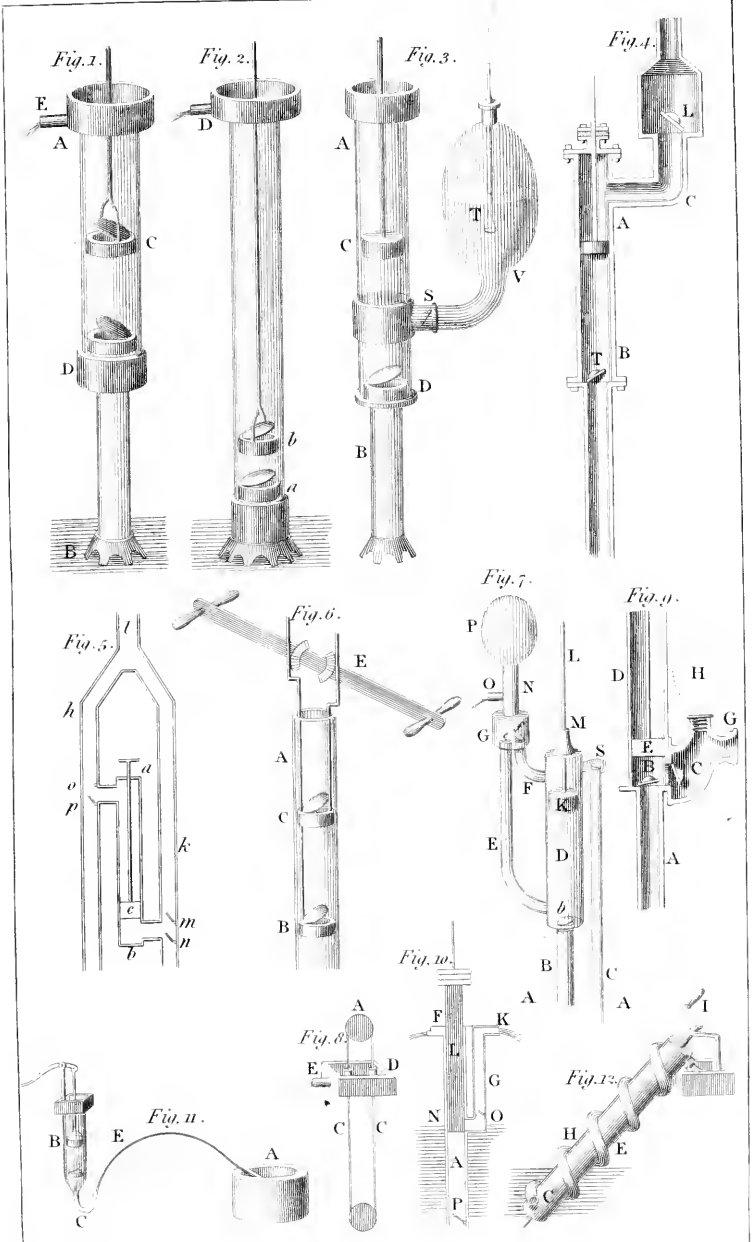
Plate VII



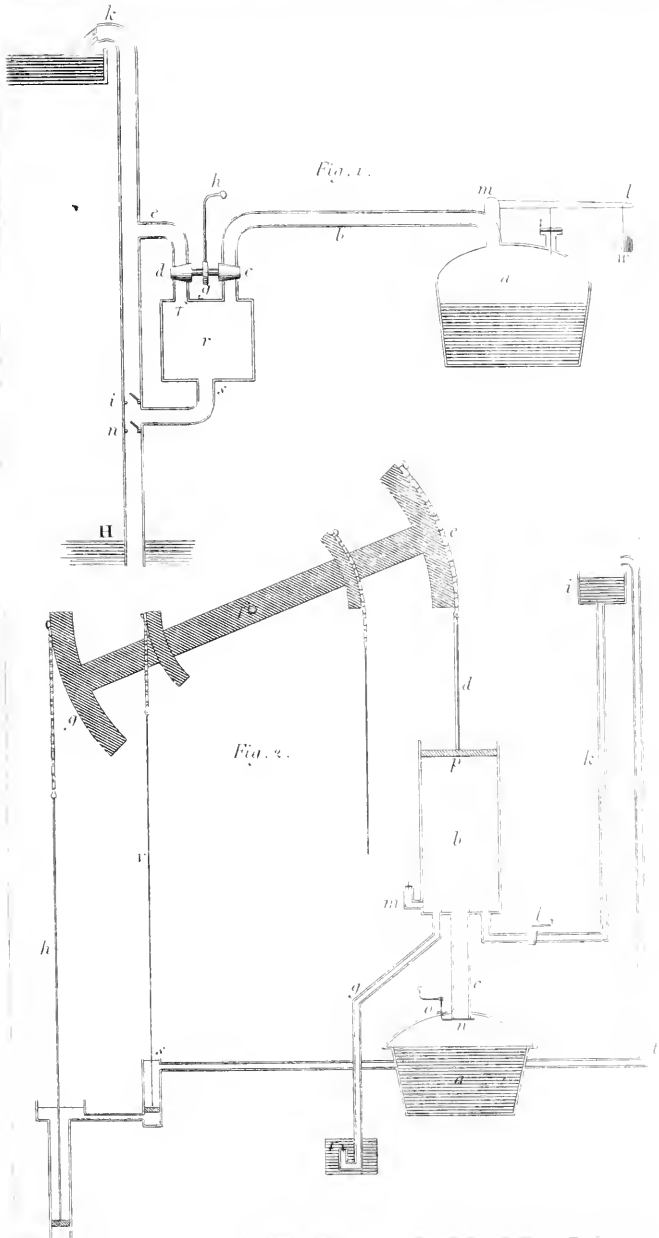


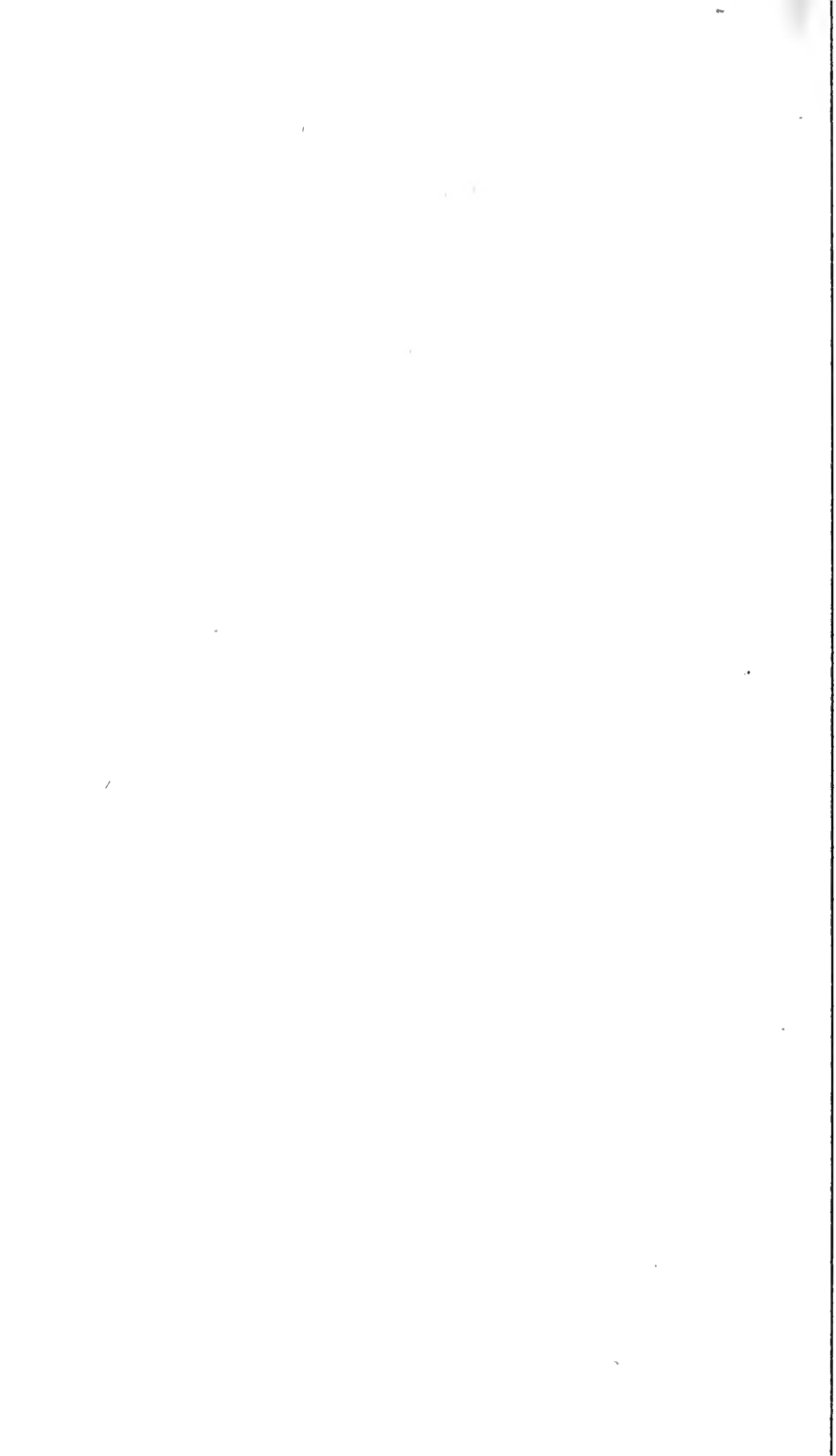


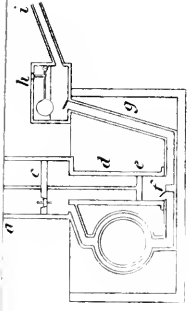
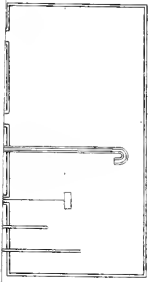






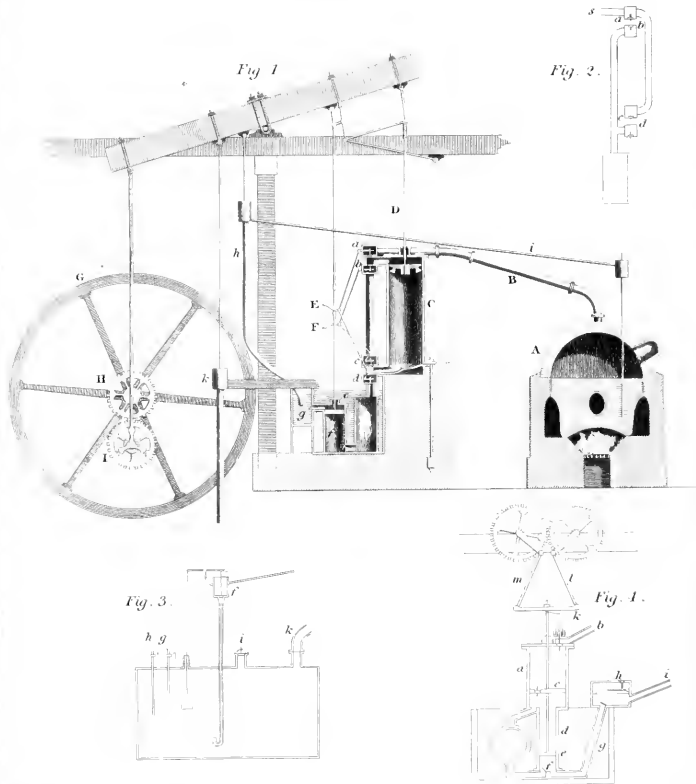




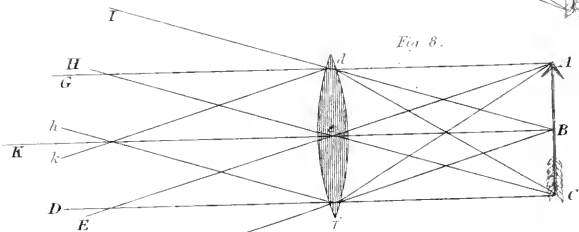
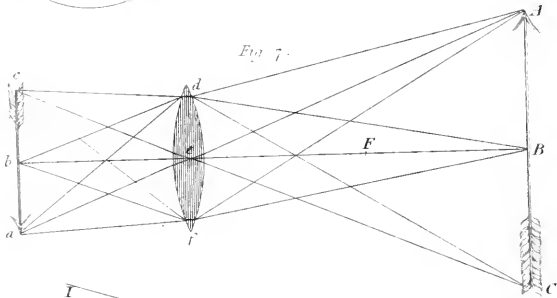
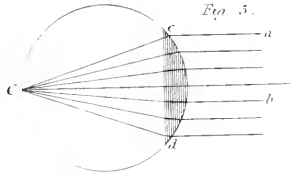
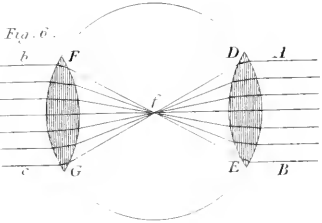
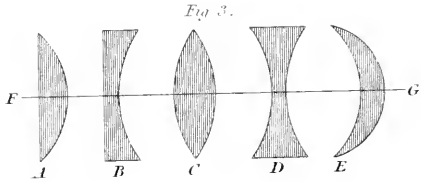
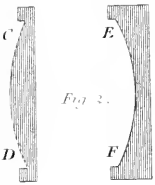
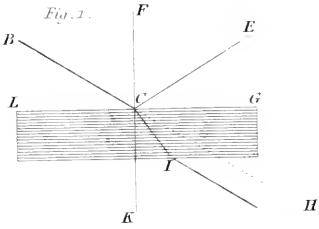


T. 18. 18. 18. 18.

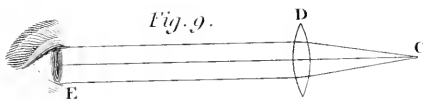
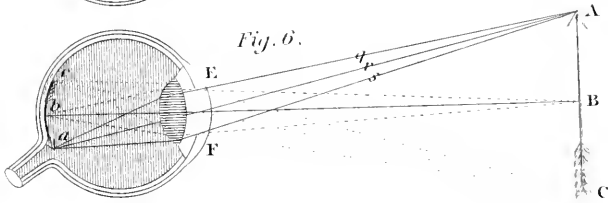
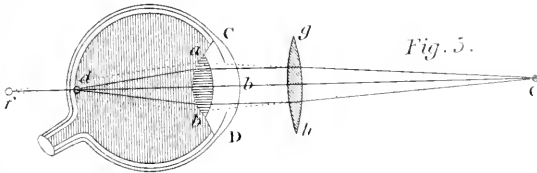
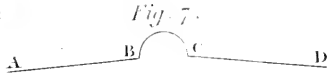
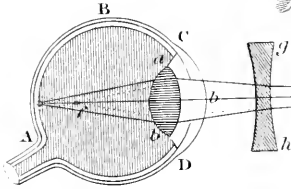
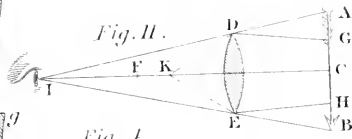
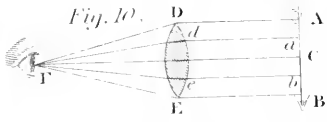
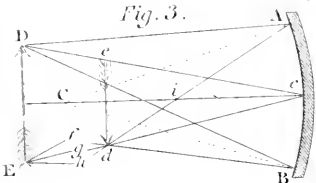
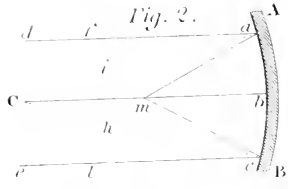
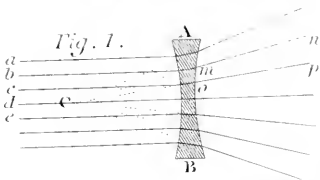
*Copied for Amos Combs of New York.*



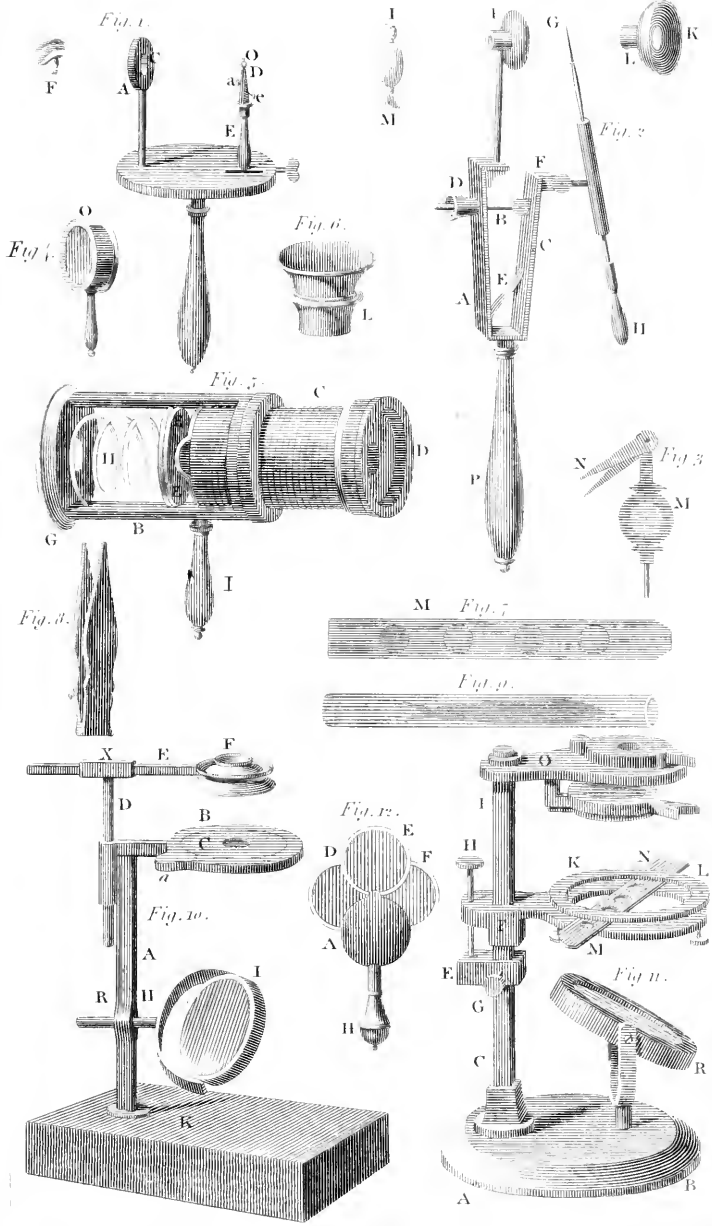




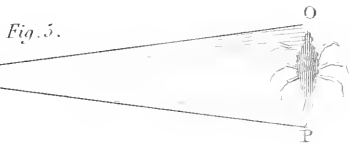
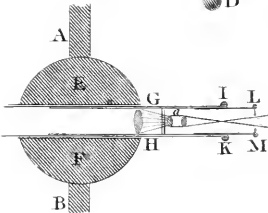
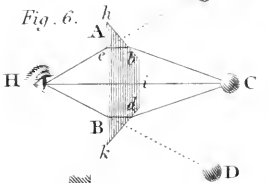
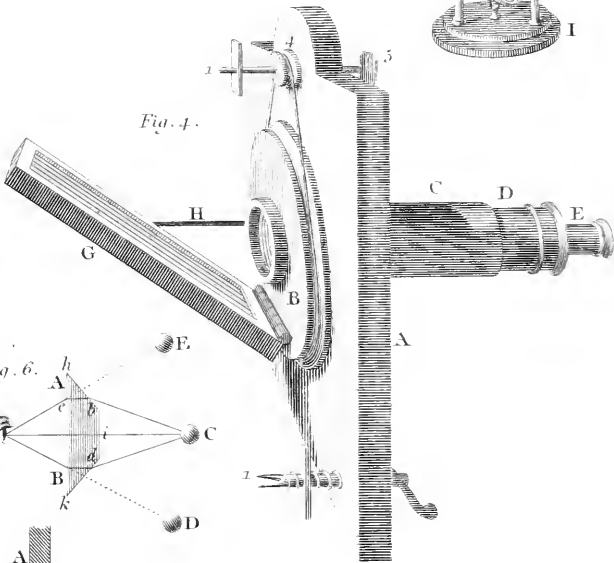
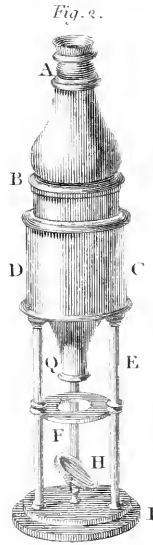
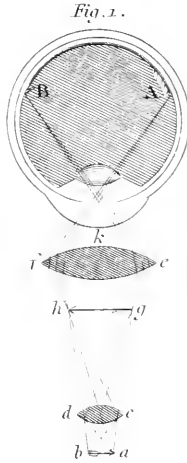
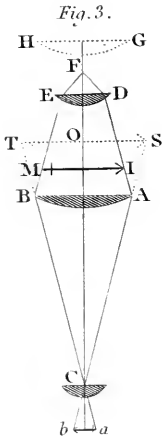
















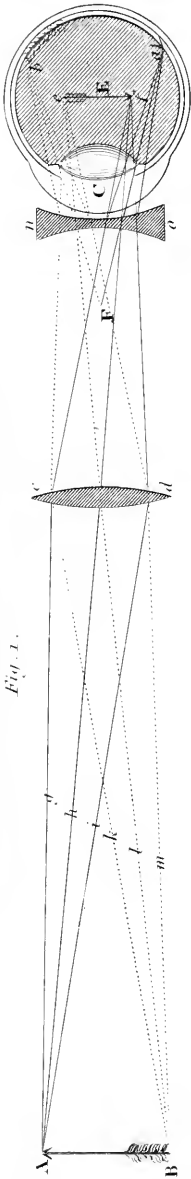


Fig. 1.

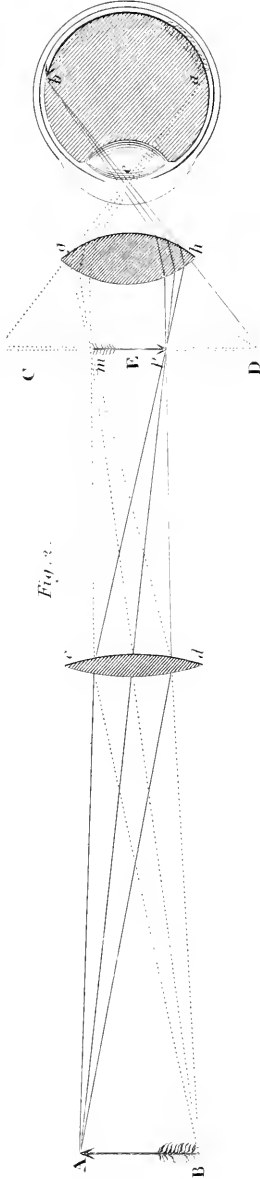


Fig. 2.

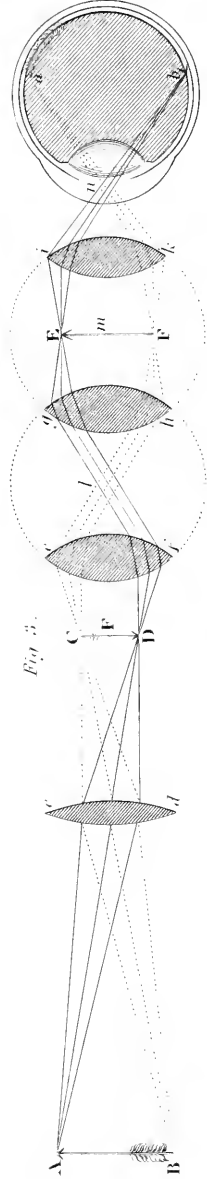
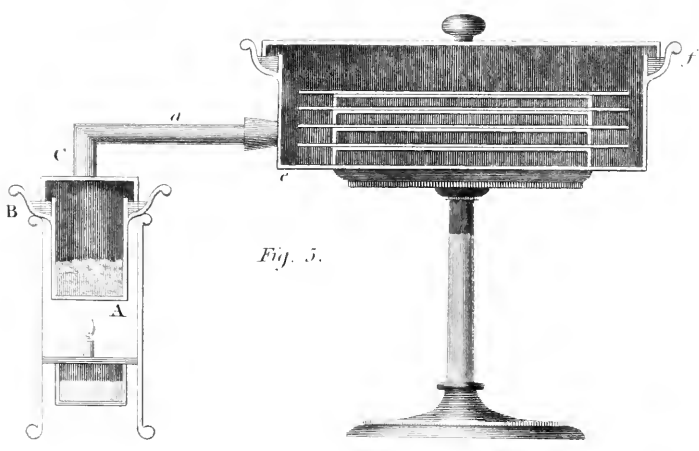
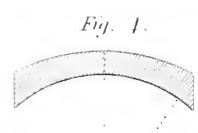
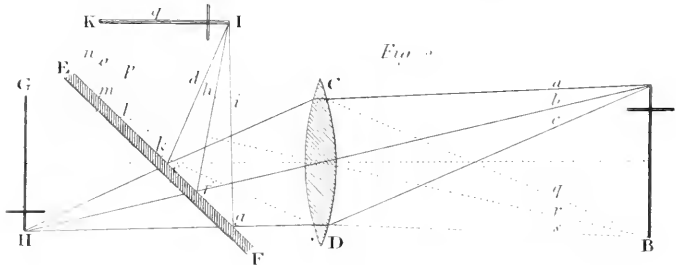
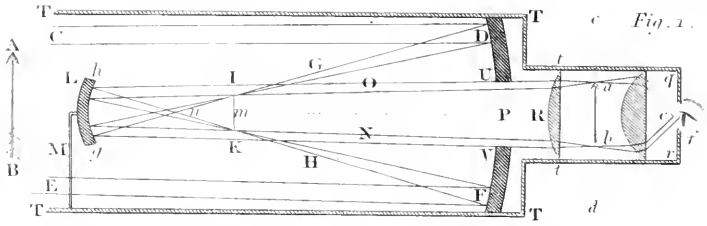


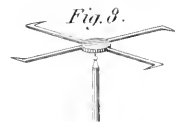
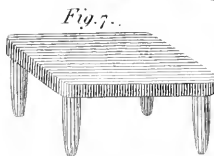
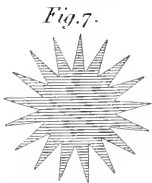
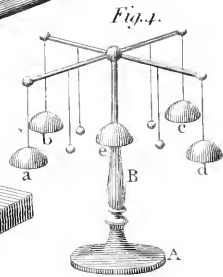
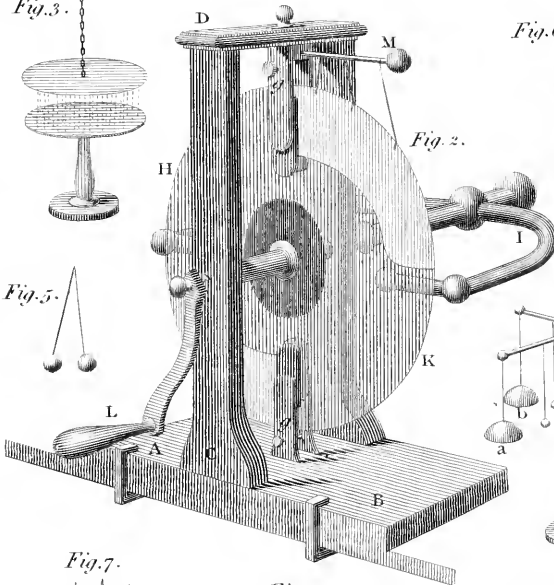
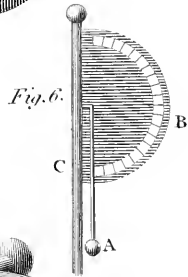
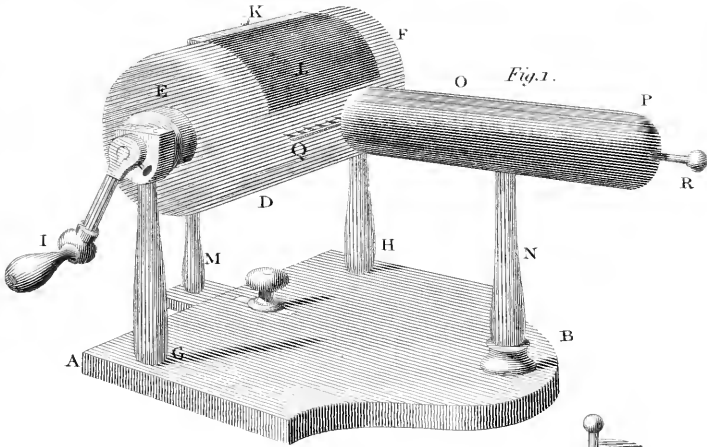
Fig. 3.







ELECTRICITY.





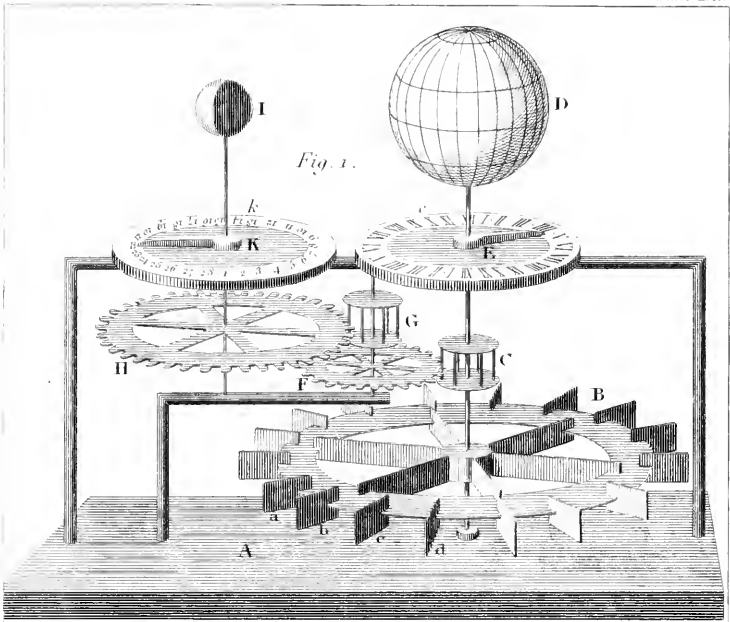


Fig. 1.

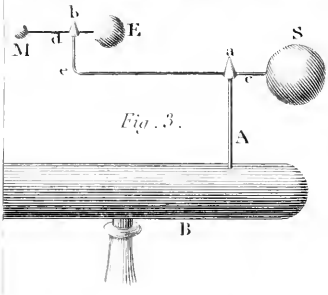


Fig. 3.

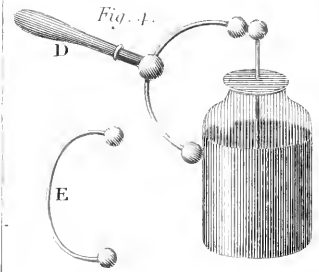


Fig. 4.

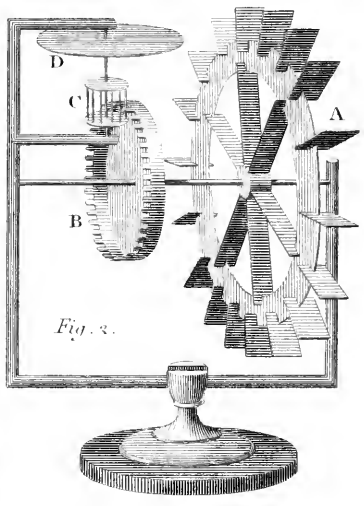
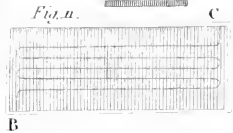
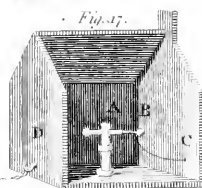
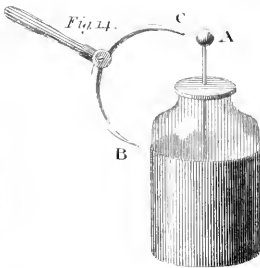
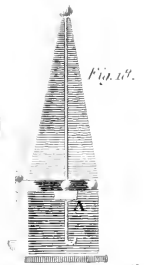
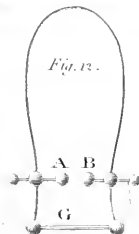
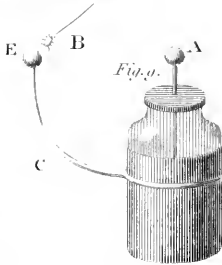
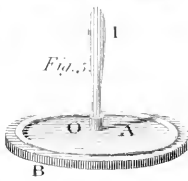
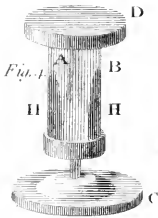
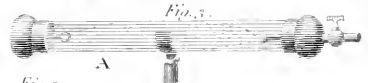
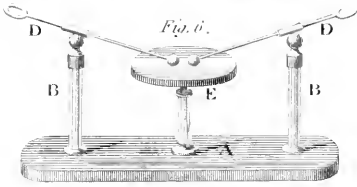
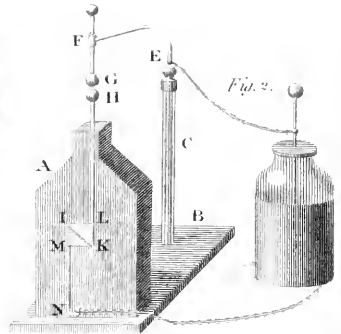
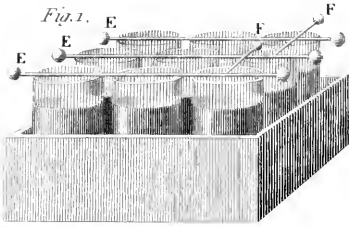


Fig. 3.

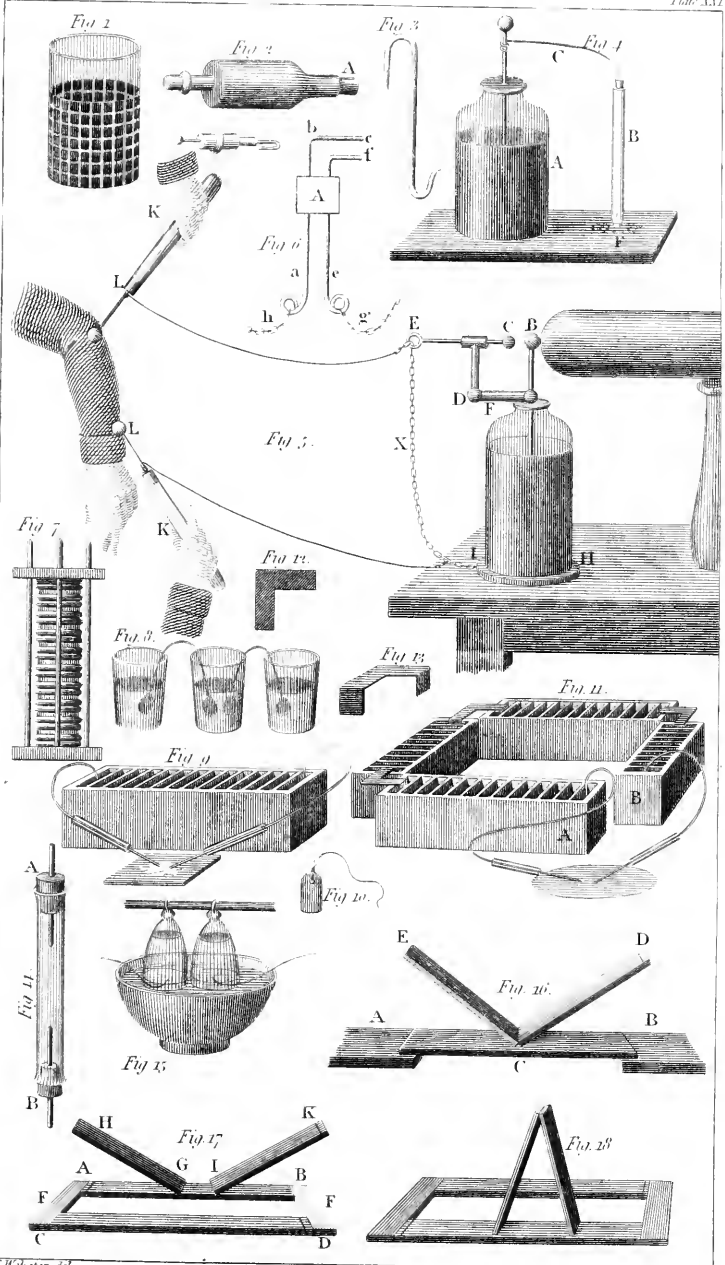




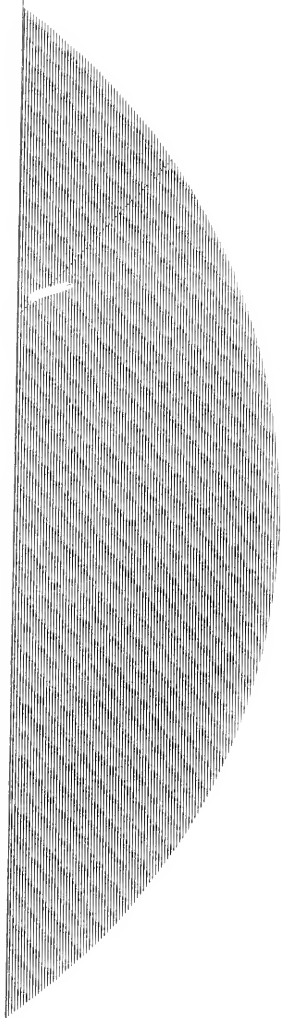
ELECTRICITY.













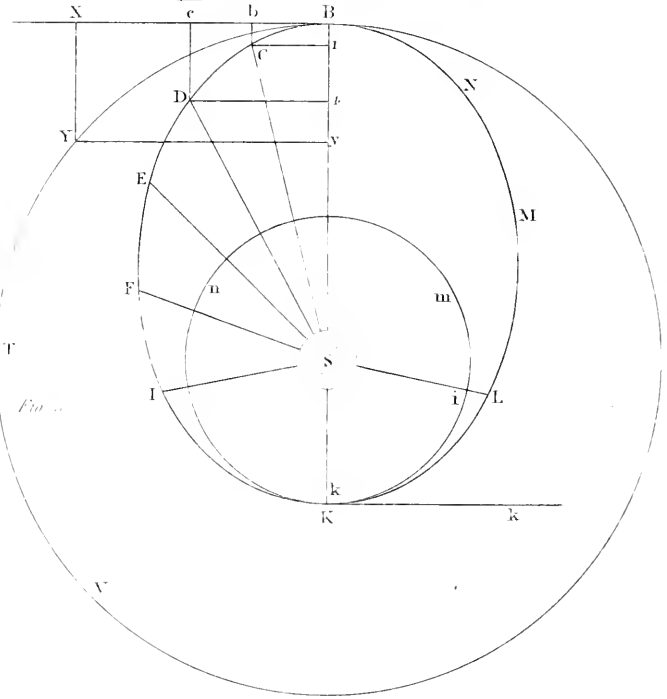
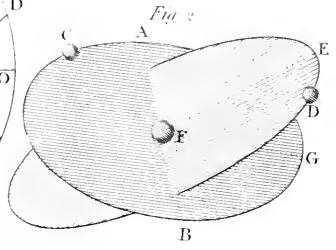
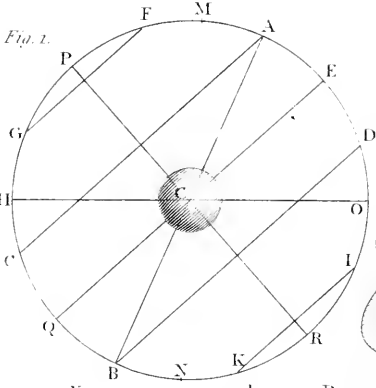






Fig 1.

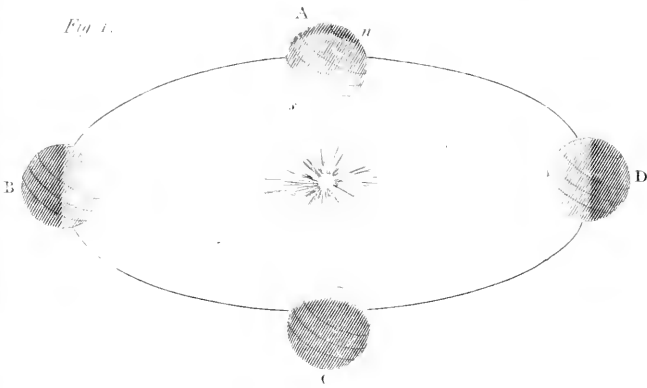


Fig 2.

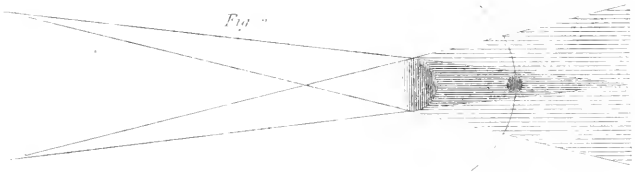


Fig 3.

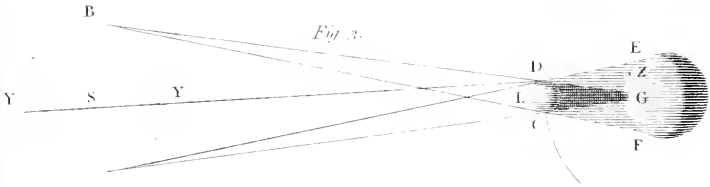
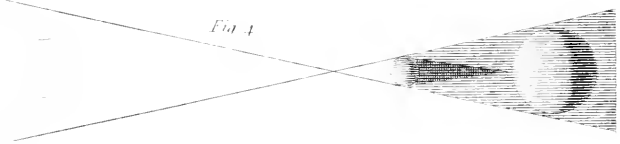
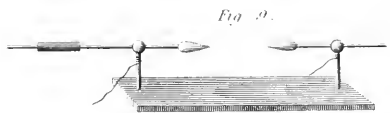
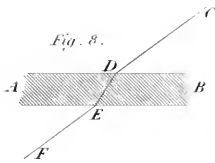
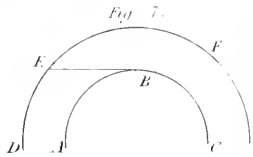
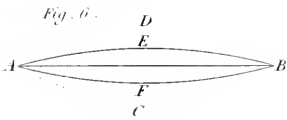
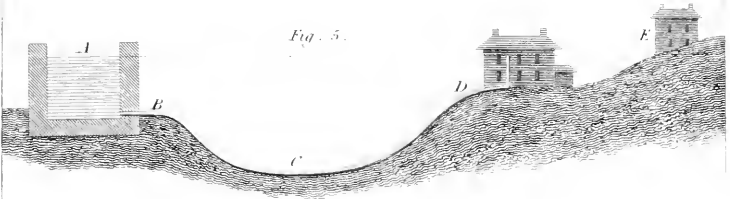
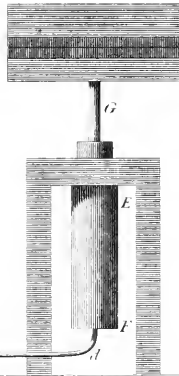
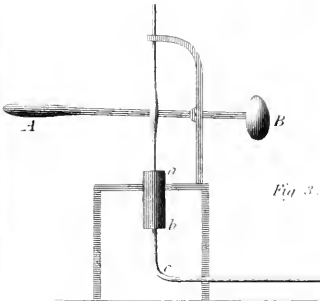
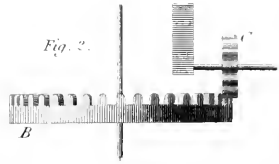
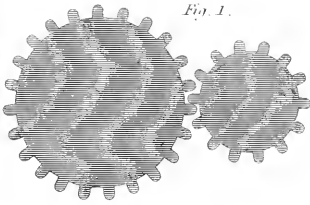
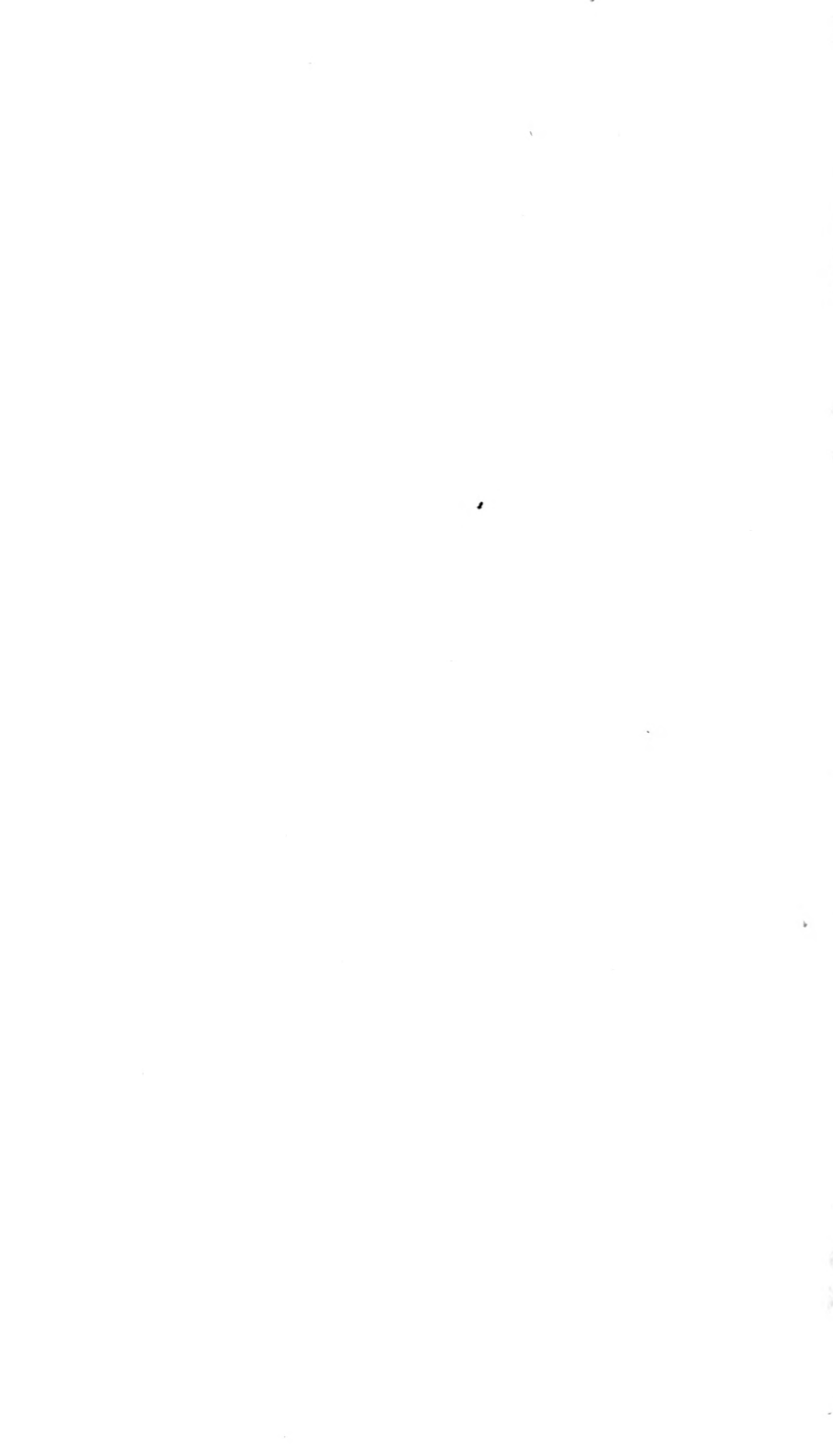


Fig 4.









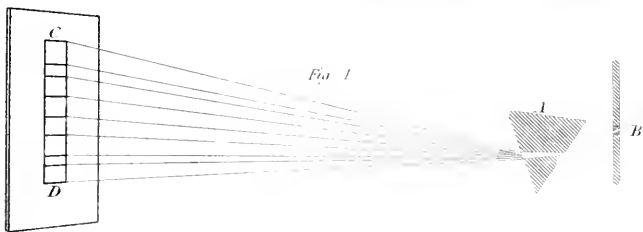


Fig. 1

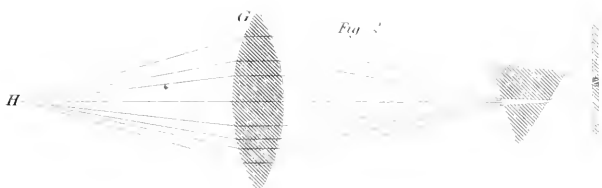


Fig. 2

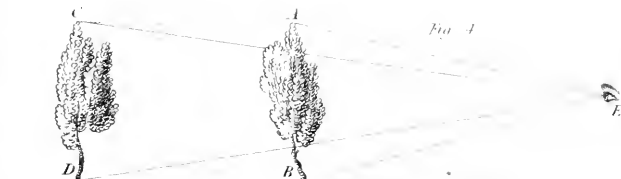


Fig. 4



Fig. 3

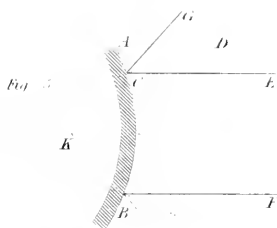


Fig. 5

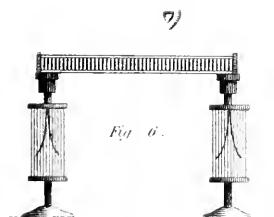


Fig. 6.

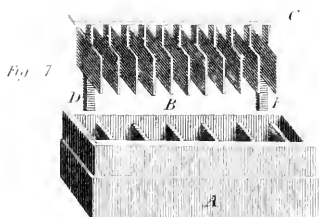


Fig. 7





84 16061



78-BX-13

11  
- 3.1  
( )

DATE  
SERIAL

GETTY CENTER LIBRARY



3 3125 00140 7101

