

Digitized by the Internet Archive  
in 2007 with funding from  
Microsoft Corporation

D. 61  
B

# THE ELEMENTS OF VEGETABLE HISTOLOGY

Charles

BY  
**C. W. BALLARD**

*Associate Professor of Materia Medica and Director of the Microscopical  
Laboratory, College of Pharmacy, Columbia University. Microanalyst,  
Department of Health, City of New York*

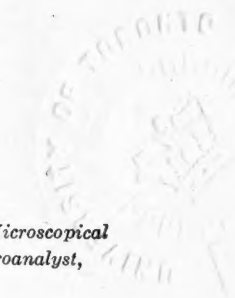

168440.  
9.1.22.

NEW YORK  
**JOHN WILEY & SONS, Inc.**

LONDON: CHAPMAN & HALL, LIMITED

1921

Copyright, 1921  
BY  
C. W. BALLARD

PRESS OF  
BRAUNWORTH & CO.  
BOOK MANUFACTURERS  
BROOKLYN, N. Y.

## PREFACE

---

A KNOWLEDGE of vegetable histology is the foundation for the studies of microscopic pharmacognosy and microanalysis of foods. It is so intimately related to the studies of plant morphology and plant biology that these subjects should be considered prerequisite or should parallel the course in plant histology.

This volume is intended for the beginner; and, in many instances, details have been omitted in order that the student may obtain a knowledge of general principles without being confused by the minutiae of the subject. Those intending to specialize in vegetable histology, pharmacognosy and microanalysis of foods will find a wealth of detail in the reference books noted in the Appendix.

The amount of laboratory work in vegetable histology performed by the student is necessarily governed by the amount of time at his disposal. Lectures should be abridged if necessary, in order that a greater amount of laboratory work may be accomplished, for in no other branch of science is the personal equation of such importance in the proper interpretation of findings. Microscope equipment for a class should be as nearly uniform as possible in order that the complications due to different magnifications may be eliminated.

The writer would indeed be remiss if he did not at this opportunity express his appreciation of the

influence of Dr. H. H. Rusby, Professor of Materia Medica, College of Pharmacy, Columbia University. Dr. Rusby's labors have been a source of inspiration; and association with him has been responsible for whatever measure of success the writer has attained in the field of microanalysis.

For constructive criticism and generous aid in revision of the manuscript, I am indebted to Fanchon Hart, Instructor in Materia Medica, College of Pharmacy, Columbia University, who by kindly help has greatly expedited the issuance of this manual.

Acknowledgment is also due the Bausch & Lomb Optical Co., E. Leitz and the Spencer Lens Co., for the use of illustrations and data from their several catalogues.

COLUMBIA UNIVERSITY,  
COLLEGE OF PHARMACY.  
November, 1920.

C. W. B.



# CONTENTS

---

## CHAPTER I

### THE PREPARATION OF SPECIMENS

	PAGE
Sectioning Methods.....	1
Infiltration Method.....	2
Fixation.....	2
Dehydration.....	3
Clearing.....	4
Infiltration.....	5
Embedding.....	6
Section Cutting, Hand and Machine Microtomes.....	7
Ribbon Sectioning.....	13
Removal of Embedding Media.....	14
Embedding Method for Non-infiltrated Specimens.....	15
Fresh Materials.....	15
Dried Materials.....	16
Blocking for Cutting.....	16
Synopsis of Sectioning Methods.....	17

## CHAPTER II

### THE MOUNTING OF SPECIMENS

Mounting Media.....	20
Preparation of Glycerin Jelly Mounts.....	21
Preparation of Canada Balsam Mounts.....	23

## CHAPTER III

### THE MICROSCOPE

The Optics of the Microscope.....	24
Refraction.....	24
Types of Lenses.....	25
Optic Axis.....	26

	PAGE
Principal Focus.....	26
Focal Distance.....	26
Real Images.....	27
Virtual Images.....	28
Spherical and Chromatic Aberrations.....	29
The Simple Microscope.....	31
Construction and Uses.....	31
The Compound Microscope.....	33
Optical Parts.....	35
Objectives.....	35
Oculars.....	38
Condensing Lenses and Mirror.....	39
Mechanical Parts.....	41
Use of the Compound Microscope.....	44
Position of Microscope and Worker.....	45
Lighting.....	45
Focusing with Low Powers.....	46
Focusing with High Powers.....	48
Summary of Focusing Technic.....	49
Use of the Eyes.....	49
Cleaning the Microscope.....	50
Interpretation of Images.....	51
Drawings.....	52

## CHAPTER IV

## THE CHEMICAL REACTIONS OF PLANT TISSUES

Chemical Properties of Cell Walls.....	57
Cellulose Walls.....	58
Lignified Walls.....	58
Cutinized and Suberized Walls.....	59
Gums and Pectinous Substances.....	59
Chemical Properties of Cell Contents.....	60
Starch.....	61
Inulin.....	61
Sugars.....	62
Alkaloids.....	62
Glucosides.....	63
Calcium Oxalate.....	63
Aleurone.....	64
Tannins.....	64

## CONTENTS

vii

	PAGE
Resins.....	64
Silica.....	65
Calcium Carbonate.....	65
Fats.....	65

## CHAPTER V

### STAINING

General Considerations.....	66
Saturation Stains.....	66
Double Stains.....	67
Acid Fast Stains.....	67
Differential Stains.....	68
Stains for Cell Walls.....	68
Cellulose.....	68
Lignified Tissues.....	68
Cutinized and Suberized Tissues.....	68
Gums.....	69
Pectins.....	69

## CHAPTER VI

### THE PLANT CELL

General Considerations.....	70
Cytology.....	71
Protoplasm.....	71
Protoplasmic Contents.....	71
Non-protoplasmic Contents.....	72
Parts of the Cell.....	72
Structure of the Cell Wall.....	73
Methods of Growth.....	73
Origin of Cells and Tissues.....	74
Mitosis.....	74
Plant Tissues.....	77
Fundamental Tissues.....	77
Primary Root Tissues.....	77
Secondary Root Tissues.....	80
Primary Stem Tissues.....	83
Secondary Stem Tissues.....	83

	PAGE
Parenchyma .....	84
Prosenchyma.....	84
Summary of Root and Stem Tissues.....	86

## CHAPTER VII

## THE COVERING TISSUES

General Considerations.....	87
Epidermal Tissues.....	88
Membranous Tissues.....	88
Stomata.....	89
Subepidermal Cells.....	89
Striations.....	89
Beaded Walls.....	89
Thickened Epidermal Tissues.....	92
Seed and Fruit Epidermis.....	92
Plant Hairs or Trichomes.....	92
Non-glandular Trichomes.....	94
Classification.....	94
Glandular Trichomes.....	99
Classification.....	100
Cork or Periderm.....	101

## CHAPTER VIII

## SUPPORTING TISSUES

General Considerations.....	104
Fibrous Tissues.....	105
Classification of Fibers.....	108
Wood and Bast Fibers.....	108
Sclerenchymatic Tissues.....	108
Classification of Stone Cells.....	110
Collenchymatic Tissues.....	112

## CHAPTER IX

## ABSORPTION TISSUES

General Considerations.....	113
Absorption of Water.....	113
Root Hairs.....	113

	PAGE
Absorption of Gases.....	115
Stomata.....	115
Respiration.....	117
Transpiration.....	118
Lenticels.....	119

CHAPTER X

CONDUCTING TISSUES

General Considerations.....	120
Ducts.....	120
Types of Ducts.....	121
Tracheids.....	122
Sieve Tubes.....	122
Sieve Plates.....	122
Medullary Rays.....	124
Latex Tubes.....	126
Porous Parenchyma.....	127
Fibro-vascular Tissues.....	127
Types of Fibro-vascular Bundles.....	127

CHAPTER XI

TISSUES FOR SYNTHESIS, ASSIMILATION AND STORAGE

General Considerations.....	132
Photosynthesis.....	132
Formation of Starch.....	132
Assimilation, Soluble and Reserve Starch.....	134
Formation of Inulin.....	135
Formation of Aleurone and Hydrocarbons.....	135
Formation of Calcium Oxalate.....	136
Formation of Glucosides.....	136
Secreting Cells and Cavities.....	136
Glandular Hairs.....	137
Secretory Cavities.....	137
Unicellular Secretion Cells.....	139
Vittae.....	140
Storage Tissues.....	140
Parenchyma.....	140
Secretion Cavities.....	141
Collenchyma.....	141
Cavities of Stone Cells and Fibers.....	141

## CHAPTER XII

## CELL CONTENTS

	PAGE
General Classification.....	142
Starch.....	143
Classification of starch grains.....	143
Inulin.....	144
Sugars.....	144
Alkaloids.....	146
Glucosides.....	146
Calcium Oxalate.....	146
Classification of Crystals.....	146
Tannins.....	148
Gums.....	148
Resins.....	148
Fats and Fixed Oils.....	148
Silica.....	148
Calcium Carbonate.....	148
Aleurone.....	150

## CHAPTER XIII

## ROOT STRUCTURES

Primary Root Structures.....	151
Arrangement of the Tissues.....	151
Characters of the Tissues.....	152
Epidermis.....	152
Hypodermis.....	154
Cortical Parenchyma.....	154
Endodermis.....	155
Phloem Bundles.....	155
Xylem Bundles.....	156
Pith Parenchyma.....	157
Secondary Root Structures.....	158
Changes incidental to Formation of Secondary Tissues.....	158
Arrangement of the Tissues.....	158
Characters of the Tissues.....	158
Cork.....	158
Phellogen.....	160
Cortical Parenchyma.....	160

Phloem and Xylem Bundles.....	160
Cambium.....	161
Medullary Rays.....	161
Cell Contents of Roots.....	162
Tabulation of Functions of the Root Tissues.....	162

## CHAPTER XIV

## STEM STRUCTURE

Primary Stem Structures.....	163
Arrangement of the Tissues.....	164
Characters of the Tissues.....	166
Epidermis.....	166
Hypodermis.....	166
Cortical Parenchyma.....	167
Endodermis.....	167
Phloem, Cambium and Xylem Tissues.....	168
Pith Parenchyma.....	168
Cell Contents in Primary Stems.....	168
Tabulations of Functions of the Primary Stem Tissues.....	169
Secondary Stem Structures.....	169
Changes incidental to the Formation of Secondary Tissues... ..	170
Bark Structures.....	170
Arrangement of the Tissues.....	171
Characters of the Tissues.....	171
Cork.....	171
Phellogen and Phelloderm.....	171
Cortical Parenchyma.....	176
Medullary Rays.....	176
Phloem Elements.....	176
Cell Contents in Barks.....	177
Wood Structures.....	177
Arrangement of the Tissues.....	177
Characters of the Tissues.....	178
Xylem Elements.....	178
Medullary Rays.....	179
Pith Parenchyma.....	182
Cell Contents in Woods.....	182
Tabulation of Functions of the Secondary Stem Tissues.....	182
Rhizomes.....	183

## CHAPTER XV

## LEAF STRUCTURES

	PAGE
Tissues Present in Leaves.....	184
Arrangement of the Tissues.....	184
Characters of the Tissues.....	184
Epidermis.....	184
Palisade Cells.....	187
Leaf Parenchyma or Mesophyll.....	188
Fibro-vascular Tissues.....	189
Cell Contents in Leaves.....	190
Tabulation of Functions of the Leaf Tissues.....	190

## CHAPTER XVI

## FLOWER STRUCTURE

Tissues Present in the Flower.....	191
Arrangement of the Tissues.....	191
Characters of the Tissues.....	192
Bract Tissues.....	192
Calyx Tissues.....	192
Corolla Tissues.....	194
Stamen Tissues and Pollen.....	194
Pistil Tissues.....	195
Stem Tissues.....	196
Cell Contents in Floral Parts.....	196
Tabulations of Functions of the Tissues present in Floral Organs .	196

## CHAPTER XVII

## FRUIT STRUCTURE

General Considerations.....	198
Creomocarps.....	198
Exocarp Tissues.....	199
Mesocarp Tissues.....	199
Endocarp Tissues.....	201
Drupaceous Fruits.....	201
Black Pepper.....	201
Exocarp Tissues.....	201



	PAGE
Mesocarp Tissues.....	202
Endocarp Tissues.....	202
Cell Contents Present in Fruits.....	205
Tabulation of Functions of the Tissues Present in Fruits.....	205

## CHAPTER XVIII

## SEED STRUCTURE

Parts of the Seed.....	206
Tissues Present in Seeds.....	206
Arrangements of Tissues in Wheat Seed.....	207
Testa and Tegmen Tissues.....	207
Endosperm Tissues.....	207
Embryo Tissues.....	209
Arrangement of Tissues in Black Mustard Seed.....	209
Testa and Tegmen Tissues.....	209
Endosperm Tissues.....	211
Embryo Tissues.....	211
Cell Contents of Seeds.....	212
Tabulation of Functions of the Tissues present in Seeds.....	212

## CHAPTER XIX

## MICROSCOPE ACCESSORIES

Mechanical Stage.....	213
Micromesurements.....	214
Ocular Micrometers.....	215
Standardization of Micrometers.....	215
Filar Micrometers.....	217
Unit of Micromesurement.....	217
Camera Lucida.....	217
Polarizing Apparatus.....	219
Nicol Prisms.....	220
Analyser.....	220
Polarizer.....	220
Crossed and Uncrossed Positions.....	221
Isotropic Substances.....	221
Anisotropic Substances.....	221
Selenite Plates.....	221
Microscope Lamps.....	222

## APPENDIX

	PAGE
Formulae for Reagents and Stains . . . . .	224
Table of Magnifications with Different Combinations of Objectives and Oculars . . . . .	230
Data Relative to Objectives of the Different Powers . . . . .	230
Numerical Aperture . . . . .	230
Working Distance . . . . .	230
Diameter of Real Field . . . . .	230
Initial Magnification . . . . .	230
Cover-slips; Thickness, Sizes, Shapes and Designations . . . . .	231
Approximate Number of Cover-slips to the Ounce . . . . .	231
Reference Books . . . . .	232

# THE ELEMENTS OF VEGETABLE HISTOLOGY

## CHAPTER I

### PREPARATION OF SPECIMENS

THE preliminary operations in the preparation of plant tissues for micro-examination include sectioning and powdering of the material under consideration. Either or both of these procedures may be necessary because plant organs are usually too large and too thick for direct examination. Although much information may be gained from a surface examination by the use of reflected light, it must be remembered that details of inner structure are of the greatest importance in vegetable histology and a knowledge of these details can only be gained through examination of powdered or sectioned materials.

#### SECTIONING METHODS

The methods employed in the preparation of sections or thin slices of plant parts vary according to the texture of the tissues and the type of section required. In general, the methods may be divided into (*a*) those in which infiltration, or the permeation of the cell with a supporting medium, is necessary and (*b*) those in

which infiltration with a supporting medium is unnecessary.

#### INFILTRATION METHOD

This method of treating materials for sectioning is used in the preparation of specimens of animal tissues and the finer types of vegetable sections, especially those used to illustrate the protoplasmic contents and the parts of the living cell. In brief, the process consists in killing the tissue without disturbance of the cell contents and involves a replacement of the water in the cells by a supporting medium. The necessary operations include fixation, dehydration, clearing, infiltration, embedding, cutting and staining.

**Fixation.**—The object of this process is to abruptly terminate the life of the cell, without causing too great a disturbance of the protoplasmic contents, and to harden materials of very soft texture. By this means we secure specimens showing the protoplasmic elements of the cell. The fixing agents in common use include formalin, picric acid, chromic acid, chromates, osmic acid and combinations of mercuric chloride with other salts. Formulæ for several fixing solutions will be found in the Appendix. Specimens should not exceed 8 mm. in size, else the fixing fluid will not rapidly penetrate the material. The time required for thorough fixing depends upon the texture of the material, the fixing fluid employed and the size of the specimen. After fixation the specimen must be thoroughly washed in water unless otherwise directed. If colored fixing fluids are used, it is well to continue washing until the wash water is free of color. If stained specimens are desired, the staining may be performed after washing

out the fixing fluid, although the advisability of staining at this point depends upon the type of stain employed and the kind of material one is working with.

**Dehydration.**—Paraffin or collodion may be used as a supporting medium in the infiltration process, but as both of these substances are immiscible with water, dehydration or removal of water from the cells is essential. The removal of water from cellular material must be accomplished gradually, and the water must be replaced by liquids miscible with the paraffin or collodion used as a supporting medium. Too rapid replacement of water would result in injury to the cell contents if not to the cell walls. As the process of dehydration is dependent upon the exosmosis of water and the endosmosis of the dehydrating fluid, the rapidity of the process is governed by the permeability of the cell walls. The dehydrating medium usually employed in vegetable histology is ethyl alcohol. After fixing and washing, the tissue fragments are placed in alcohol and water mixtures of gradually increasing concentrations, finally reaching absolute alcohol. The length of time the specimen should remain in each mixture depends upon the character of the tissues, woody structures requiring more time than those with soft membranous walls. In a specimen containing various kinds of tissue one must adjust the time of dehydration so as to secure full penetration of the thicker walled tissues. As a specimen is not likely to be injured by remaining too long in the alcohol and water mixtures, it is better to give the maximum time to each step in the process.

Dried materials may also be prepared for sectioning by the infiltration process, but in this case, fixing or

killing the tissues is unnecessary. The specimen is immediately immersed in the low-concentration alcohol and carried through in the manner prescribed for materials in which fixing is necessary. The details of the dehydration of materials may be summarized as follows:

1. Immerse specimen in alcohol 30 per cent for twenty-four hours
2. " " " 50 " " " "
3. " " " 70 " " " "
4. " " " 95 " " " "
5. " " " absolute (a) for twenty-four hours
6. " " " " (b) " six "
7. " " " chloroform for three to six hours

**Clearing.**—The object of clearing is to make the cell walls and contents more translucent. Due to the action of the dehydrating medium, or on account of the nature of the specimen, the cell walls may be more or less opaque. The clearing agent corrects this condition and enables us to see structures which, because of this opacity, would not otherwise be apparent. In dealing with vegetable materials possessing thin and semi-transparent walls clearing may not be necessary. But even with such materials it is advisable to immerse the specimen, if only for a short time, in a clearing fluid in order to assure a more thorough penetration of the tissues by the paraffin. The use of chloroform after the absolute alcohol partly serves this purpose. The clearing agents employed include clove oil, cedar oil, turpentine oil, phenol and xylol and mixtures of these. After dehydration the specimens are placed in the clearing fluid for a period of from six to twenty-four hours, depending upon the texture and size of the specimen. The material should become almost transparent

in the clearing fluid. If the specimens become cloudy or white upon transference to the clearing agent, it is an indication that dehydration is incomplete. In this case the material must be returned to the stronger alcohol mixtures and a longer time allowed for dehydration.

**Infiltration.**—When the water within and around the cells has been replaced by chloroform, and the cell walls rendered transparent by means of a clearing medium, the next step is to introduce melted paraffin into the cavities of the cells and into the intercellular spaces. As previously stated, the paraffin serves as a supporting medium and prevents collapse of the specimen during section cutting. Melted paraffin will dialyse through cell walls, but the rate of dialysis can be materially hastened by immersing the specimen in a saturated solution of paraffin in chloroform or xylol. After this treatment the specimen may be transferred to melted paraffin kept at a temperature just above melting point. The paraffin for this purpose is especially prepared and the several grades obtainable range in melting point from 45° C. to 55° C. The grade to be employed depends upon the season and the texture of the specimen. In hot weather it is more satisfactory to use paraffin of higher melting point than that used in cold weather. The temperature of the paraffin bath must be kept fairly constant and slightly above the melting point. Infiltration will be slow or incomplete if the paraffin is too cold. If the temperature of the paraffin bath rises much above the melting point there is great danger of rupturing cell walls. The steps in the infiltration process are as follows:

1. Place the specimens in saturated solution of paraffin in chloroform or xylol for six to twelve hours.
2. Transfer specimens to melted paraffin (bath *A*) for two to four hours.
3. Transfer specimens to melted paraffin (bath *B*) for four to eight hours.

**Embedding.**—The last process in the infiltration method consists in surrounding the specimen with sufficient paraffin to support it during sectioning.



FIG. 1.—Paraffin Mold.  
(Bausch & Lomb.)

Metal or paper molds are used for this purpose. The metal molds (Fig. 1) are adjustable for different sized specimens and permit more rapid chilling of the paraffin than is possible with paper molds. Melted paraffin is poured into

the mold so as to form a layer about 8 mm. in depth. The mold is then placed in a shallow dish of cold water so that the paraffin on the bottom and sides will congeal quickly. The specimen is placed in the soft paraffin in the center of the mold, care being taken to place it so that the surface from which the sections are to be cut is toward the narrow end of the block and that the entire specimen is parallel with the long side of the mold. This *orientation*, or proper placing of the specimen, is necessary if one desires to obtain exact transverse sections and wishes to avoid frequent shifting of the block while cutting. After the specimen is properly placed, melted paraffin is poured into the mold so that the layers of paraffin on each side of the specimen



are about equal in thickness. The filled mold is now rapidly cooled by immersion in cold water, care being taken to see that the water does not flow over the surface of the paraffin until a fairly thick pellicle is formed. Rapid cooling is necessary in order to prevent crystallization of the paraffin, as this would cause chipping and crumbling during cutting. After the paraffin is thoroughly hardened the mold is removed, and the block containing the specimen is trimmed so that approximately equal thicknesses of paraffin surround the specimen on all sides. The blocks are most satisfactory when they are small; their length should not exceed 25 mm.

The placing of the specimen in the block depends upon the view or aspect of the object one desires. *Transverse* or *cross-sections* are cut parallel to a plane extending at right angles to the long axis of the specimen. *Radial* or *radial-longitudinal* sections are cut parallel to a plane extending through the long axis of the specimen and passing through the center of the object. *Tangential* sections are cut parallel to a plane extending through the long axis of the specimen but not passing through the center.

#### SECTION CUTTING

**Free-hand Sections.**—The simplest method of obtaining sections is by means of the section razor or hand microtome. This instrument is similar to a heavy razor except that it is flat on one side and concave on the other. Although with practice one may readily cut a small number of fairly good sections by this means, it is difficult to secure uniformity as regards thickness and size of sections. The block containing

the specimen is held between the thumb and forefinger of the left hand. The forefinger serves as a support for the flat side of the razor and the thumb should be a safe distance below the level of the block so as to avoid accident. The razor, held in the right hand, is drawn obliquely across the block, making a complete slice of supporting material and specimen. Moistening the block with a mixture of glycerin, alcohol and water is advisable, and the sections should be transferred to this liquid as soon as cut.

**Microtome Sections.**—The microtome is a mechanical device for cutting sections. It consists of a clamp to hold the block and knife for cutting the sections.



FIG. 2.—Hand Microtome.  
(Spencer.)

The object-clamp is so fitted that one may cut sections of definite thickness. In the simpler forms (Figs. 2 and 3), the hand microtome is used instead of a special blade, and the object-clamp is fitted in a screw-thread, so that the block may be moved to definite distances above the level surfaces upon which the flat side of the section razor rests. The milled head by which the object-clamp is raised upon turning through the screw-thread is usually graduated in micro-millimeters. The more complex forms of microtomes may

be divided into sliding (Fig. 4), and rotary (Fig. 5) types. The sliding microtomes are further sub-

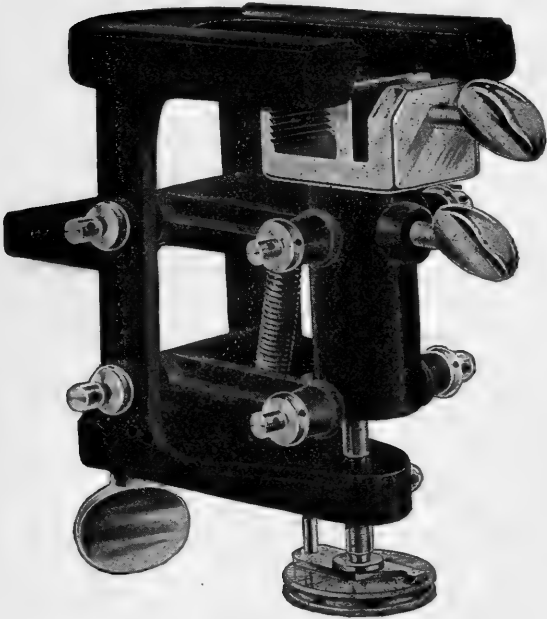

FIG. 3.—Hand Microtome.  
(Spencer.)

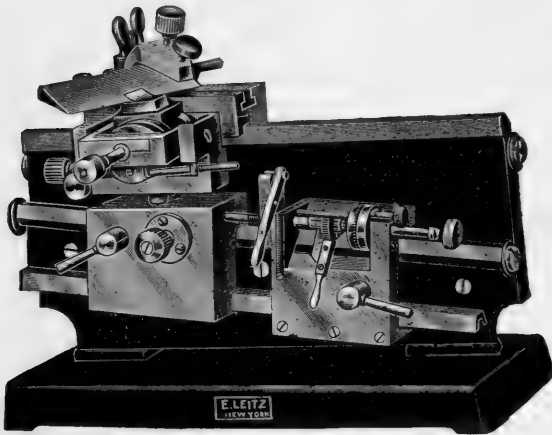

FIG. 4.—Sliding Microtome.  
(Leitz.)

divided into those in which the object-clamp is fixed and the knife is movable (Fig. 4), and those in which the object-clamp is movable and the knife is fixed (Fig. 6). The type with sliding knife is less liable to injure delicate specimens in cutting, because the block does not come into as sudden contact with the knife as in those machines in which the knife is rigid. Rotary microtomes are usually of the fixed-knife type and are so constructed that the object is fed toward and brought into contact with the knife at each revolution of a flywheel. Thickness of section is adjusted by means of a graduated cam, which limits the movement of a pawl in contact with a large toothed wheel, the shaft of which is threaded and inserted in the object-clamp. As the object strikes squarely against the knife edge, this type of microtome can only be used for sectioning fairly soft materials and those which are of even texture throughout. It is the most rapid in operation, as one need only turn the flywheel to obtain sections. All types of microtomes should be kept free of dust and all moving parts should be well greased or oiled. Microtome knives must be kept well sharpened and should show a straight edge without overhang when examined under low magnification. Different types of knives are required for objects of various textures, and each should be reserved for its particular purpose. In general, a heavy knife for wood and a second knife for materials of medium texture will answer all purposes and cover a fairly wide range. Knives having a flat side should be sharpened only on the concave surface, with perhaps a few finishing strokes on the flat side.

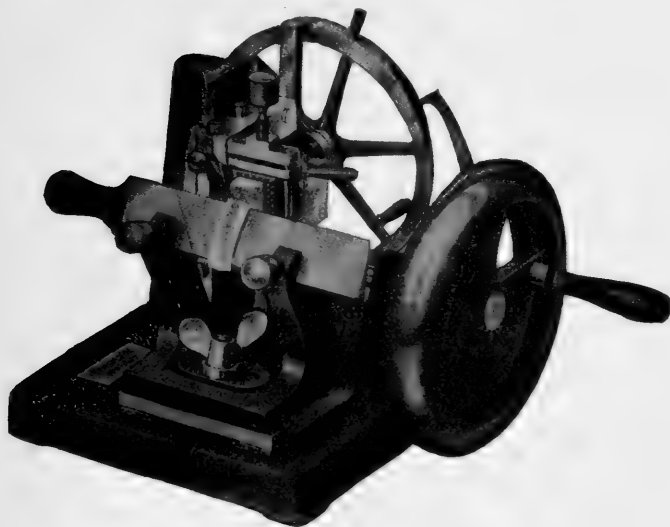

FIG. 5.—Rotary Microtome.  
(Leitz.)

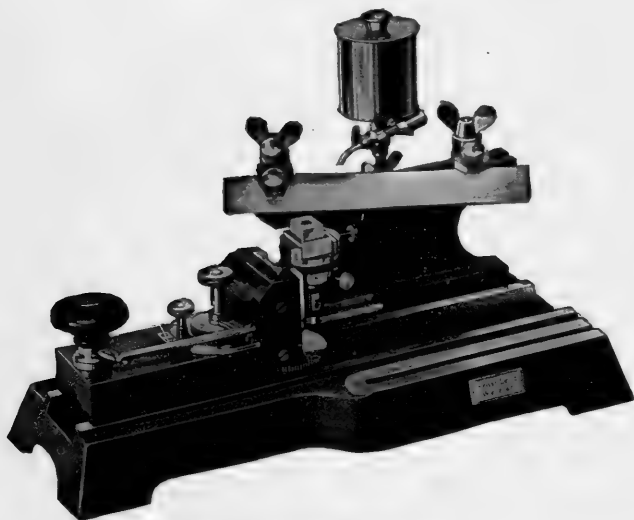

FIG. 6.—Sliding Microtome.  
(Leitz.)

**Microtome Technic.**—Fix the block in the object-clamp, placing thin strips of cork on the sides in contact with the gripping surfaces. These cork strips serve as buffers and allow one to draw up well on the tightening screws with little danger of injury to the block. After the block is firmly fastened, place the knife in position so that it clears the block and object-clamp. The position of the knife varies with different embedding media. For objects embedded in paraffin the knife should be placed at an angle to the block. For objects in celloidin or collodion the knife should be placed straight, so that the block strikes it squarely. The knife should be adjusted so that the cutting edge is slightly lower than the flat side, otherwise one will have a continuous resistance to the block at each stroke. After the block is secured and the knife properly placed, ascertain the thickness of section desired and set the indicator at the proper figure. Adjust the object-clamp so that the block is within a few millimeters of the knife edge and trim away the paraffin from the upper surface of the block until the specimen is visible. Move the object-carrier toward the knife with a slow and steady stroke, or if operating a rotary machine, turn the wheel steadily and not too rapidly. After cutting a few sections it is well to examine them under the microscope. If the sections are not cutting true or through the desired plane, use the adjusting screws located near the object-clamp and make repeated adjustments until satisfactory sections are secured. If the object is fairly straight the adjustment need not be changed after true sections are obtained. With bent or twisted objects continuous change of adjustment is necessary. Be sure

that the block is firmly clamped and tighten occasionally.

**Ribbon Sections.**—At times it is desirable to cut a series of sections showing the variations in structure in different parts of a plant organ. This is accomplished by cutting in such a manner that each section

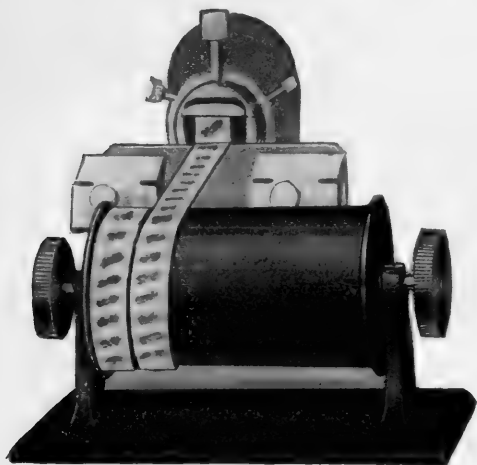

FIG. 7.—Ribbon Carrier.  
(Spencer.)

with its adherent paraffin forms part of a continuous strip or ribbon in which each section follows the preceding in regular sequence. This operation is only possible with small objects, as one cannot conveniently manage or mount the long ribbons resulting from large specimens. Success in ribbon sectioning depends upon the texture of the paraffin, the shape of the block and the temperature of the knife. Very soft paraffin must be used and crystallization during embedding must be prevented. The edges of the block must

be accurately trimmed so that the opposite sides are parallel, and the knife kept warm during the operation. Rotary machines give better ribbons than sliding microtomes. In cold weather very good results may be obtained by placing the machine on a radiator. After the first few sections have been cut, they should be gently drawn away from the knife and attached to a revolving drum (Fig. 7) so that the entire series may be kept intact. Curling of sections may be partially overcome by warming the block, as this fault is usually the result of using hard paraffin. Frictional electricity is occasionally a disturbing element, but this may be overcome by running a ground wire between the machine and a water or gas-pipe.

**Removal of Embedding Medium.**—Unless the sections are to be stained they are now immersed in xylol to dissolve the paraffin. It is best to use two xylol baths, draining the sections after the first immersion and using fresh solvent for the second. After being washed in xylol the sections may be mounted in balsam or may be brought into aqueous media by reversing the operations described in the section on Dehydration. If the sections are to be stained, and particularly if one is working with serial or ribbon sections, each section with the adhering paraffin is laid flat upon a clean slide previously prepared so that the sections will adhere. Slides for this purpose are coated with a mixture of egg albumin and glycerin (1 : 1) and then dried at a moderate temperature. Just previous to use, the albuminous film is moistened with water. The prepared slide with the specimens properly arranged is placed upon a warm plate or in a low temperature oven and gently heated so that



the water will evaporate. Upon evaporation of the water, the specimen will be found firmly fixed to the slide. Melting of the paraffin during this operation is of no consequence. After being thoroughly dried, the slide is immersed in xylol to dissolve the paraffin. As aqueous solutions of stains are usually employed, the specimen must be partially rehydrated by immersion in alcohol 95 per cent, 80 per cent and 70 per cent, at least three minutes being allowed in each concentration. The stain is now applied (refer to Chapter IV, Staining), after which the specimen is again dehydrated by passing through alcohol 70 per cent, 80 per cent, 95 per cent, absolute No. 1 and absolute No. 2, at least five minutes being allowed in each bath. After dehydration the specimens are cleared and mounted in Canada balsam.

#### EMBEDDING METHOD FOR NON-INFILTRATED SPECIMENS

Infiltration methods for the preparation of sections are not usually employed in the routine examination of foods and drugs, as fairly good sections may be secured by more direct methods. We may divide the materials likely to be encountered into (a) those received in fresh condition or of soft texture and (b) those received in dried condition or of hard texture. The details of preliminary treatment differ slightly in each instance.

**Fresh Materials.**—Many leaves, seeds and fruits which may be classed with this group require no preliminary treatment before blocking, as they are of proper texture for direct sectioning. Other materials, including the fleshy parts of soft fruits, are too soft for sectioning and must receive a preliminary harden-

ing treatment. Hardening may be accomplished by immersion of small pieces of the material in 6 per cent formalin solution or in 50 per cent alcohol. The length of time required for hardening varies according to the texture of the material. Prolonged hardening is to be avoided, as it tends to make the specimen brittle and is apt to cause distortion of the cellular elements.

**Dried Materials.**—Dried or hard materials should be softened before blocking. Softening may be accomplished by soaking the specimen in a mixture of glycerin, alcohol, and water (1 : 1 : 1), or by boiling in water. While the glycerin mixture is slower in action it has an advantage in that with it there is little danger of rendering the specimen too soft. Gentle heating will hasten the process. With materials of exceptional hardness boiling is necessary, and small amounts of acid or alkali may be added to aid in the softening.

**Blocking for Cutting.**—As most objects are too small to be conveniently held during sectioning, it is necessary to use a supporting medium. The specimen, if fairly soft, may be placed between slices of fresh potato or carrot and thus held firmly enough for sectioning. The objection to this method of blocking is that it is often difficult to separate small portions of the blocking material from the sections, especially if the latter are of small size. Pieces of elder pith may be used as a holding medium for materials of soft texture. Paraffin is the best holding medium for non-infiltrated specimens, as it may be used with materials of almost any texture. Furthermore it can be readily separated from the sections, and by merely dipping the cut surfaces of the block

in melted paraffin the specimen may be preserved for future reference. Paper or metal molds are prepared as directed in the section on Infiltration. The paraffin should have a melting point not higher than 60° C. A layer of paraffin is poured into the mold and cooled, the surface of the specimen is dried, after which it is dipped into the melted paraffin and placed in proper position upon the layer of paraffin already in the mold. Melted paraffin is now poured into the mold so as to cover the specimen, enough being added to form a substantial layer over the latter. It must be borne in mind that paraffin undergoes considerable contraction upon cooling. After the paraffin is thoroughly hardened the mold is removed and the block trimmed to convenient size. Sections may be cut by hand or by machine according to the methods outlined in the section on Infiltrated Materials. The removal of paraffin from the specimens is readily accomplished by placing the sections with the adhering paraffin in a beaker, adding water and gently heating. With most specimens a complete separation is thus effected, as, upon cooling, the paraffin accumulates on the surface of the water and the sections remain at the bottom.

### SYNOPSIS OF SECTIONING METHODS

#### *Infiltration Method:*

1. Fixing and hardening.
2. Washing to remove fixing agent.
  - (a) Staining may be desirable at this point.
3. Dehydration.
4. Clearing.
5. Infiltration.
6. Embedding.

7. Sectioning.

(a) Fixation of specimen on slide, if necessary.

8. Removal of infiltration medium.

(a) Mounting in Canada balsam.

(b) Complete rehydration if specimens in aqueous media are desired.

9. Partial rehydration.

10. Staining.

11. Removal of excess stain.

12. Dehydration.

13. Clearing.

14. Mounting in Canada balsam.

*Non-infiltration Method:*

1. Hardening of soft materials or softening of hard materials.

2. Blocking.

3. Sectioning.

4. Removal of blocking material.

(a) Staining may be accomplished at this point.

5. Mounting in glycerin jelly.

## CHAPTER II

### MOUNTING OF SPECIMENS

THE preparation of objects or specimens for observation by means of the microscope is termed *mounting*. This operation consists in placing the specimen upon a glass slide, surrounding it with a suitable mounting medium and covering it with a thin piece of glass known as a *cover-slip* or *cover-glass*. The slides employed are usually 25 by 75 millimeters in size and should be clear of flaws.

The purpose of the mounting medium is three-fold; first, to correct excessive differences in refractive index between the specimen and the air; second, to fix the specimen in place; third, to preserve the specimen for future use. Comparatively few vegetable materials can be examined satisfactorily without the use of mounting media. To obtain clear views, contrast is necessary; and this can only be obtained through the use of mounting media of suitable refractive index. The refractive indices of specimen and mounting medium should be neither too near nor too far apart and the ideal mounting medium is between these extremes.

The cover-slip serves to fix the specimen in place, checks excessive evaporation of the mounting medium, prevents dust from lodging upon the specimen and protects the lenses of the microscope. It is essential that slides and cover-slips be thoroughly cleaned

before mounting specimens. These slips of glass are usually covered with a film of dirt which cannot be removed by simple polishing. They should be boiled in water containing a trace of ammonia, transferred to alcohol and dried with a silk or linen cloth. The cleaning mixtures listed in the appendix are very efficient. The use of cotton or woolen cloth for cleaning glassware or lenses is objectionable because of the fibers which adhere to the glass and which may be mistaken for parts of the specimen under examination. Clean slides and cover-slips should be kept free from dust and handled only by their edges. Finger prints which are almost invisible to the naked eye are very apparent when highly magnified.

#### MOUNTING MEDIA

Mounting media are classified as temporary and permanent. Temporary mounting media include fixed oils, volatile oils, water, glycerin, chloral hydrate solutions and alcohol. Mixtures of water and glycerin with or without the addition of alcohol may often be used to advantage. The oils and chloral hydrate solution may be used in mounting specimens containing so much fatty material that cloudiness would result from attempts to mix them with aqueous media. Temporary mounts are well adapted to routine examinations of food and drug samples, where preservation of the specimen is not essential and where the work upon a sample does not extend over too long a period of time. Owing to evaporation of the medium, if it be water or alcohol, or absorption of moisture if it be glycerin, these temporary mounts cannot be

preserved without special treatment. A further disadvantage of temporary mounts is that they cannot be readily transported.

The permanent mounting media include glycerin jelly, Canada balsam and solutions of various resins. Glycerin jelly is used in most instances because it is readily miscible with the aqueous or alcoholic media generally used for the preservation of stock specimens. Glycerin jelly is prepared with gelatin, glycerin and water with a trace of phenol as a preservative (refer to Appendix). Specimens mounted in glycerin jelly will last at least five years if kept under favorable conditions. Canada balsam is a liquid oleoresin obtained from the tree *Abies balsamea*. It is a thick liquid of pale yellow color and when used as a mounting medium is usually mixed with xylol. As it is immiscible with water it cannot be used unless the specimens are dehydrated by being passed through increasing strengths of alcohol and finally through xylol or chloroform. The balsam gradually solidifies and forms a varnish. The mounts are absolutely permanent, but crystals of resin acids may separate from the balsam and obscure the specimen. The refractive index of Canada balsam is less than that of glycerin jelly; therefore when working with very delicate objects mounted in balsam it is customary to stain or color the specimens so that clearer views may be had.

#### PREPARATION OF GLYCERIN JELLY MOUNTS

*Materials required:*

- Slides and cover-slips.
- Knife.
- Needles.

Forceps.

Glycerin jelly.

Alcohol lamp or Bunsen burner.

*Operation:*

1. Arrange the requisite number of clean slides in regular order and attach temporary labels, or number with ink.
2. Obtain specimen. These materials are usually preserved in a mixture of equal parts glycerin, alcohol and water.
3. Cut a cube of glycerin jelly ( $\frac{1}{8}$  inch) and place it near the specimen.
4. Clean the needle by passing through the flame, removing the carbonized material by wiping upon clean paper.
5. Melt the cube of glycerin jelly by holding the slide a few inches above the flame. If mounting sections of plant parts, allow the melted jelly to flow over the specimen and proceed to step 6. If mounting powdered materials, make an intimate mixture of melted jelly and specimen.  
CAUTIONS.—Keep the slide warm, use the point of the needle for mixing; secure even mixture; keep mixture within small area; use as little heat as possible; remember that boiling causes formation of bubbles and spoils the specimen.
6. Pick up clean cover-slip with forceps and slightly warm it; allow it to touch the mixture of melted gelatin and specimen; withdraw the forceps, so that cover-slip gradually comes into contact with entire mixture. If excessive amounts of jelly have been used it will be necessary to press gently on the cover-slip, forcing out the excess, so that the mount will not be too thick for observation.  
CAUTIONS.—Do not track jelly on upper surface of cover-slip; do not attempt removal of excess jelly at this time.
7. Clean needle immediately, as directed in (4).

After mounting specimens allow them to remain flat until the jelly hardens. Excess jelly should not be removed until a few days after mounting, as this medium hardens slowly. To remove excess, scrape off as much as possible with a knife and then rub gently with silk or linen cloth moistened with alcohol.



**PREPARATION OF CANADA BALSAM MOUNTS***Materials required:*

- Clean slides and cover-slips.
- Needles.
- Forceps.
- Tube of Canada balsam.
- Alcohol lamp or Bunsen flame.

*Operation:*

1. Place numbered or labeled slides in regular order.
2. Obtain specimen. This material must be thoroughly dry or suspended in xylol, chloroform or turpentine oil.
3. Place small drop of balsam upon specimen.
4. Clean needle.
5. Warm the balsam slightly and mix the specimen thoroughly with it.
6. Place cover-slip upon the mixture of balsam and specimen.
7. Clean the needle used for mixing.

Permit the mounted specimens to remain flat for a few days, after which time the excess balsam may be removed with xylol or turpentine.

It is essential that the simple operation of mounting specimens be performed with care and clearness. Defective mounts make future observations difficult, if not impossible. Small dust particles and finger prints are of consequence when highly magnified and may seriously interfere with good work.

## CHAPTER III

### THE MICROSCOPE

THE microscope is an optical instrument which produces an enlarged image of a near and usually small object. It differs from the telescope in that the latter instrument produces enlarged images of objects so far distant from the observer that they appear small although they may be very large. The human eye cannot distinguish objects below a certain size, because the extreme light rays proceeding from such an object are so close that the image cast upon the terminations of the optic nerve or *retina* is too small to cause the stimulation necessary for vision. The function of the microscope lenses is to increase the distance between the extreme rays cast by a small object, and thus render the image received by the retina large enough to cause sufficient stimulation for vision. Magnification by a lens depends upon its ability to refract light rays. This property is in turn dependent upon the principle that light rays passing through objects of differing densities are changed in direction. Light rays passing from a medium of lesser to one of greater density will be bent toward a line at right angles to the surface of the denser medium (Fig. 8). Light rays passing from a medium of greater to one of lesser density will be bent away from a line

perpendicular to the surface of the medium of lesser density (Fig. 8). Glass being of greater density than air, light rays passing through it will be bent toward a line at right angles to its surface.

Six different types of lenses are formed by combinations of curved surfaces, either with each other

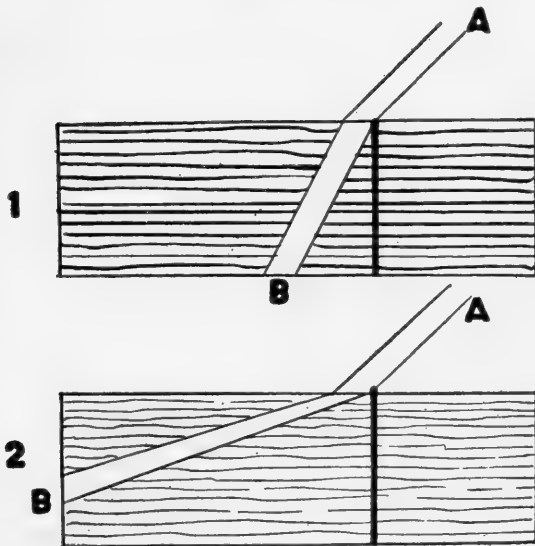

FIG. 8.—Refraction of Light Rays.

1. Path of ray passing from less dense medium (A) to one of greater density (B).
2. Path of ray passing from medium of greater density (A) to one of less density (B).

or with flat or plane faces. A lens similar to an ordinary magnifying glass is termed *convex* or *double convex*. If the lens is thinnest at the center it is termed *concave* or *double concave*. Two variations of convex lenses are recognized, *plano-convex* and *concavo-convex* or convergent meniscus. Similarly there are two variations of concave lenses, *plano-concave* and *convexo-*

*concave* or divergent meniscus. The six types of lenses are illustrated in Fig. 9. By reference to Fig. 10, it will be seen that light rays passing through the central part of a lens are not refracted. A line passing through the thickest part of a convex lens and the thinnest part of a concave lens is termed the *optic axis* or *principal axis*. Light rays passing through a convex lens are refracted toward the optic axis, whereas in concave lenses they are refracted away from the optic axis (Fig. 10). The extent of refraction or bending of light rays differs in different parts

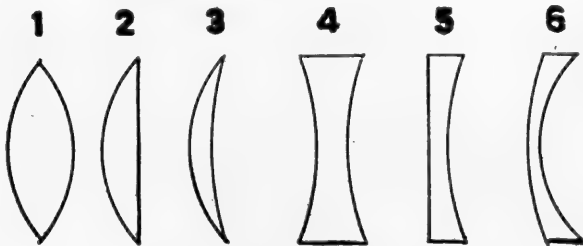

FIG. 9.—Types of Lenses.

1. Double convex. 2. Plano-convex. 3. Convexo-convex. 4. Double concave. 5. Plano-concave. 6. Concavo-concave.

of the lens. Rays entering the edges of a lens are refracted to a greater extent than those entering nearer the optic axis; therefore light rays entering a biconcave lens are bent so that they meet at a point along the optic axis. The point at which these rays cross the optic axis is termed the *principal focus*. The distance between lens and principal focus is termed the *focal distance*, or *focal length*, of the lens. A biconvex lens held in the sun will illustrate the foregoing, as it will so concentrate the light rays at a

certain point that they will slowly ignite materials placed at the principal focus.

For purposes of magnification objects are placed either beyond or within the focal point. While in both instances magnification is apparent to the

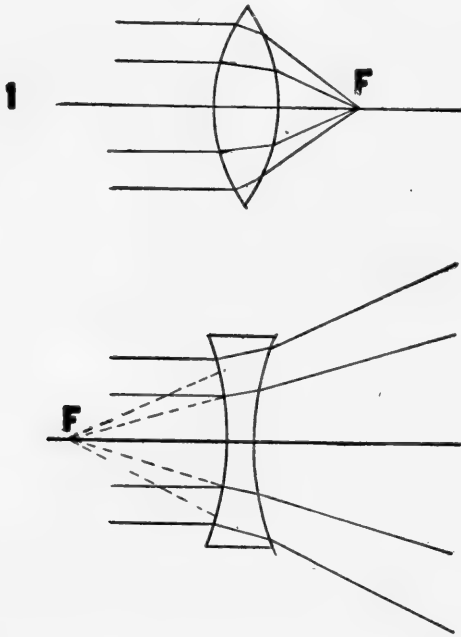

FIG. 10.—Refraction of Light Rays by Lenses.

1. Double convex lens causes convergence of rays to focal point ( $F$ ). 2. Double concave lens causes divergence of rays from focal point ( $F$ ).

observer, it will be found that the reasons for these apparent enlargements of the image are different in the two cases. Objects placed beyond the focal point of a lens will give rise to enlarged images, termed *real images*, which can be projected upon a screen. The degree of enlargement is directly proportional

to the distance of the screen from the lens. Objects placed at a point within the focal distance of a lens will also give rise to enlarged images; but these cannot be projected upon a screen and are termed *virtual images*. The changes in direction which light rays undergo in the production of a real image are entirely due to the refractive effects of the lens (Fig. 11).

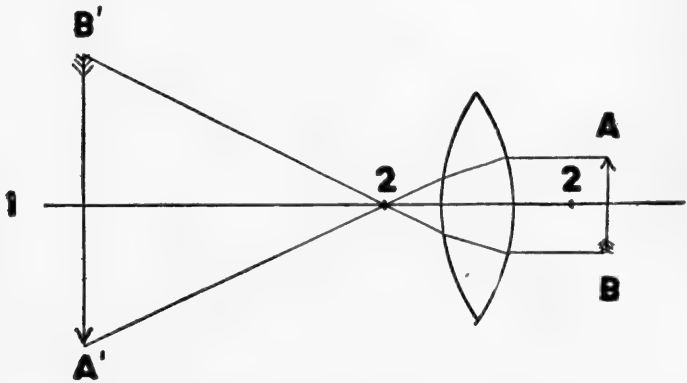

FIG. 11.—Formation of Real Image by Convex Lens.

1. Optic axis. 2. Focal points. *A-B*. Object beyond focal point (2). *A'-B'* Real Image of object *A-B*.

The apparent enlargement in the production of a virtual image is due to the action of the lens supplemented by the tendency of the eye to follow light rays through a lens disregarding the refractive effects of the latter (Fig. 12). Real images always appear inverted whereas virtual images appear erect.

Spherical and chromatic aberration are properties of lenses which formerly caused considerable difficulty. *Spherical aberration* is due to the fact that light rays

entering the edges of a lens undergo greater refraction than those entering nearer the optic axis (Fig. 13).

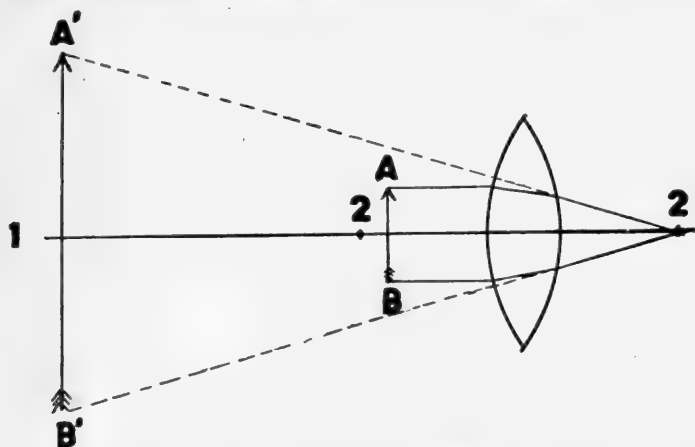

FIG. 12.—Formation of Virtual Image by Convex Lens.

1. Optic axis. 2. Focal points. *A-B*. Object within focal point (2). *A'-B'*. Virtual image of object *A-B*.

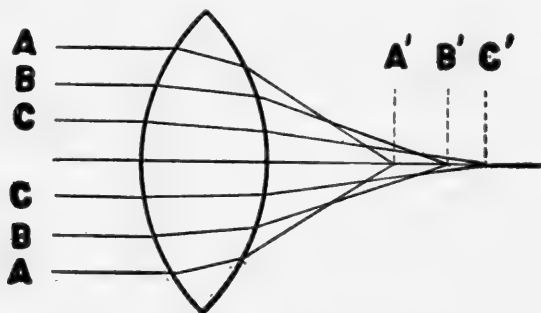

FIG. 13.—Spherical Aberration.

*A-B-C*. Light rays passing through different parts of the lens are brought to different foci, *A'*, *B'*, *C'*.

These differences in the amount of refraction cause the rays entering the center of the lens to come to a focus at a greater distance from the lens than those entering

the edges; and the resulting differences in focal points give rise to blurred images. Ordinary or white light is composed of rays of different lengths, each of which produces a specific color. A glass prism, of which a lens is but a modification, has the power of separating white light into its component rays which are of different lengths, and consequently of different colors. The play of colors resulting from the passage of light through a prism or lens is termed the spectrum

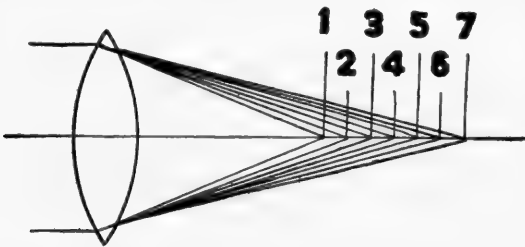

FIG. 14.—Chromatic Aberration.

The lens acts as a prism and causes dispersion of white light into rays of different colors. 1. Ultraviolet focal point. 2. Violet focal point. 3. Blue focal point. 4. Green focal point. 5. Yellow focal point. 6. Orange focal point. 7. Red focal point.

and will show the colors in the following order: red, orange, yellow, green, blue and violet. The red rays are the longest and the violet rays are the shortest (Fig. 14). Owing to the difference in wave lengths the red rays will come to a focus at a greater distance from the lens than the violet rays. These differences in focal points give rise to blurred and colored edges around the image and are responsible for the defect termed *chromatic aberration*. Both of these defects are corrected by using glass of different kinds in the construction of compound lenses and combining different types of lenses. *Achromatic lenses* are those in which chromatic aberration has been corrected.



*Aplanatic lenses* are those which have been corrected for spherical aberration.

### THE SIMPLE MICROSCOPE

The simple microscope or magnifying glass consists of a double convex lens or a combination of such lenses. The image produced appears erect, or right side up, and is a virtual magnification. The object is placed within the focal point of the lens (Fig. 12). While the field or area which can be magnified by a simple microscope is nearly as large as the diameter of the lens, the outer edges will show spherical and chromatic aberration unless the construction is such as to correct these faults. The magnification is comparatively low and seldom exceeds 25 diameters. The forms of simple microscopes range from the



FIG. 15. — Jeweler's Magnifier or Simple Microscope.

(Bausch & Lomb.)



FIG. 16. — Simple Dissecting Microscope.

(Bausch & Lomb.)

jeweler's magnifying glass or loup (Fig. 15), to complex instruments fitted with achromatic and aplanatic

lenses and various mechanical accessories for greater convenience and accuracy in manipulation (Figs. 16 and 17). While the simple microscopes do not



FIG. 17.—Dissecting Microscope  
(Bausch & Lomb.)

give high magnifications, they are of great service in work requiring views of an extensive field, as in engraving, watch repairing, textile examinations and the examination of floral parts.

## THE COMPOUND MICROSCOPE

The compound microscope consists of a series of plano-convex or converging lenses. These are mutually arranged so as to form two systems of lenses—an objective or lower combination and an ocular or upper combination. The objective, or set of lenses nearest the object, produces an enlarged image which is again magnified by the ocular lenses. Therefore the image produced by a compound microscope is the result of a double magnification. The object is placed beyond the focal point of the objective and the picture projected by this system of lenses is an inverted real image. This image is formed at a point within the focal distance of the ocular; therefore the picture formed by the ocular will be a virtual magnification of the real image produced by the objective. The object as viewed through the compound microscope always appears inverted (Fig. 18). The field or area which can be viewed is always smaller than that covered by the lens of a simple microscope. The magnifications obtainable range from 15 to 2500 diameters, although little practical application is found for magnifications above 1500 diameters. The principal parts of a compound microscope are the objective and the ocular; but mechanical devices are necessary to hold these lens systems in proper relation to each other and to the specimen. Proper support and illumination of the object must also be provided for. It is therefore customary, in considering the construction of a compound microscope, to speak of the optical parts and the mechanical parts.

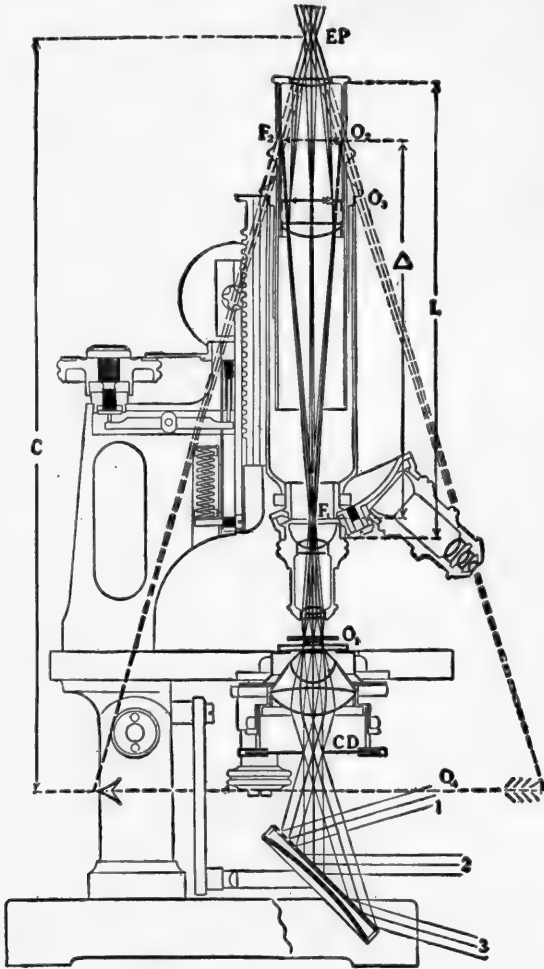

FIG. 18.—Diagram Showing Path of Light Rays.

$F_1$ , Upper focal plane of objective.  $F_2$ , Lower focal plane of eyepiece.  $\Delta$ , Optical tube length = distance between  $F_1$  and  $F_2$ .  $O_1$ , Object.  $O_2$ , Real image in  $F_2$  transposed by the collective lens, to  $O_3$ , Real image in eyepiece diaphragm.  $O_4$ , Virtual image formed at the projection distance  $C$ , 250 mm. from  $EP$ , Eyepoint.  $CD$ , Condenser diaphragm.  $L$ , Mechanical tube length (160 mm.). 1, 2, 3, Three pencils of parallel light coming from different points of a distant illuminant, for instance, a white cloud, which illuminate three different points of the object.

## OPTICAL PARTS OF THE COMPOUND MICROSCOPE

The optical parts of a compound microscope include the objectives and oculars, together with the condensing lens and the mirror.

**Objectives.**—Microscope objectives consist of one or more combinations of convex and plano-convex lenses. The lower-power objectives consist of one or two such combinations, while those used for higher magnifications consist of three or four combinations (Fig. 19). The degree of magnification produced by

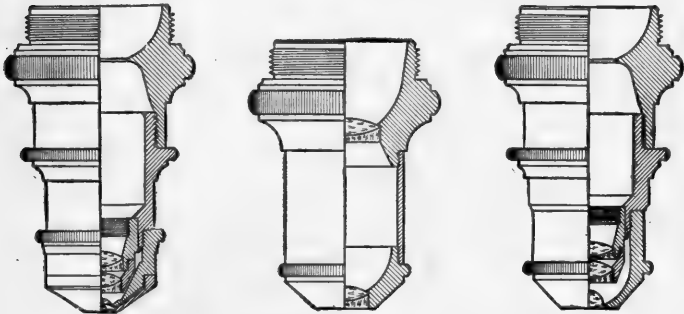

FIG. 19.—Sectional Views of Objectives.  
(Bausch & Lomb.)

different objectives is usually indicated by certain markings upon the mounting. The systems employed in the marking of objectives and oculars are the Continental, the English and the metric. The Continental system of marking objectives is entirely empirical and consists of a series of numerals beginning with No. 1, the lowest power, and continuing up to No. 9, which is the highest of the series. In the English system the relative powers are indicated in inches or fractions of an inch, usually beginning with the

2-inch objective as the lowest, and extending to the  $\frac{1}{8}$  inch or highest power. This system is based upon what is termed the equivalent focal length of the lens. An objective marked  $\frac{1}{8}$  would produce a real image of the same size as a simple convex lens, the principal focus of which is  $\frac{1}{8}$  inch distant from the lens. The metric system of marking objectives is similar to the English system and differs from the latter only in that magnification is expressed in millimeters of equivalent focal length, and not in inches or fractions of an inch. The objectives, according to this system, usually range from 48 mm., the lowest, to 1.5 mm., the highest. Briefly stated, the relation of marking to magnification is as follows: Continental system; lower numerals indicate lower powers; English and metric systems; lower numerals indicate higher powers. In the case of Continental objectives there is an exception to these rules. As previously stated, the highest powered Continental objective is ordinarily No. 9; but objectives above this power are sometimes manufactured, and are marked in fractions of an inch. Thus the sequence would be No. 9,  $\frac{1}{8}$  inch,  $\frac{1}{2}$  inch and  $\frac{1}{5}$  inch. One may judge the power of an objective by the size of the end lens, as the lower power objectives have larger end lenses than those of higher power.

In lower power lenses the refraction of light rays as they emerge from the upper surface of the glass slide is not of great consequence. In working with lenses giving high magnifications (1.9 mm.,  $\frac{1}{2}$  inch, etc.), these refractions offer serious difficulty as great amounts of light are lost because of the small diameter of the end lens. This difficulty is overcome by placing liquids between the end lens of the objective and the

slide. Air has a refractive index of 1.00, while the refractive index of glass is approximately 1.55. By placing a layer of water, which has a refractive index of 1.30, between the objective and the slide, we minimize these differences in refractive index, thus decreasing the number of light rays lost through refraction. Thickened cedar oil, of refractive index 1.55, is usually used as an immersion medium in bacteriological work

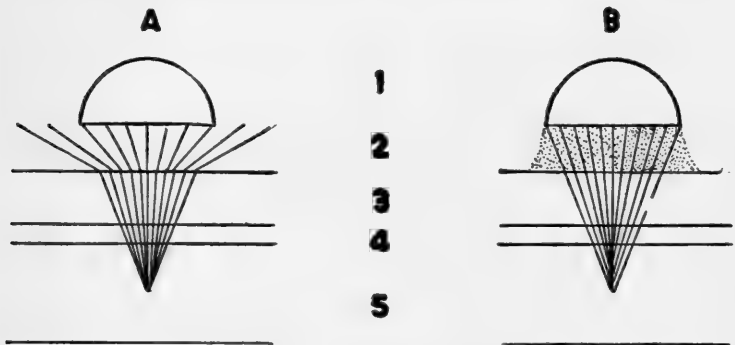

FIG. 20.—Immersion Objectives.

A. Unless immersion fluids are used, considerable light is lost through refraction. B. Very little light is lost through refraction if immersion fluids are used. 1. End lens of objective. 2. Space between objective and coverslip. 3. Coverslip. 4. Space occupied by specimen. 5. Object slide.

(Fig. 20). Lenses which cannot be used without the interposition of liquids to prevent excessive loss of light are termed *immersion objectives*, and the liquids used for this purpose are known as *immersion liquids*. Immersion lenses, while of importance in bacteriological and pathological investigations, are seldom used in vegetable histology. As immersion lenses are very expensive and easily scratched they must be handled with care, and immersion fluids must be

removed after use. This is best done by using soft lens paper moistened with xylol.

The *working distance* of an objective is the space which intervenes between the specimen and the end lens of the objective when the latter is properly focused upon the object. The working distance is in inverse ratio to the magnification, lower-power objectives having a greater working distance than those of higher power. Many objectives bear figures indicating their power to distinctly show cellular structures separated from each other by very small distances. This property is termed *resolving power* and is expressed in terms of *numerical aperture* (N. A.). The resolving power of a lens is in direct ratio to its numerical aperture; therefore an objective of N. A. 1.30 will be of greater use in the examination of very fine details than an objective of N. A. 0.85.

**Oculars.**—As previously stated, the function of an ocular is to further magnify the magnified image produced by the objective. The usual type of ocular (Huygenian or negative), consists of two plano-convex lenses separated from each other by considerable distance. A diaphragm or metal plate with a circular opening is placed between the lenses of the ocular. The magnification of an ocular is indicated by markings on the top plate or on the tube. In the Continental system, magnification of oculars is empirically indicated by numerals ranging from No. 1, the lowest, to No. 6, the highest. In the English system, degree of magnification is indicated in inches or fractions of an inch ranging, from 3 inch, the lowest, to  $\frac{1}{2}$  inch, the highest. These figures have a fixed relation to the equivalent focal distance as explained



under Objectives. The simplest method of marking oculars is by indicating the number of diameters (or times) they magnify the image formed by the objective. In this system the powers range from  $5\times$  to  $20\times$ . Where high magnification with long working distance is desired, high-power oculars may often be used to advantage. The better types of oculars are corrected for spherical and chromatic aberration. The magnifications obtainable with different combinations of objectives and oculars are stated in tabular form in the Appendix.

**Condensing Lenses and Mirror.**—The purpose of the mirror is to reflect light upon the object, thus illuminating it upon all sides. Illumination can be secured without use of the mirror; but upon viewing the object it will be found that one side is light and the other is dark. That portion of the specimen nearest the source of light is clearly defined, while that further away is obscured. Furthermore, in most instances we desire views of cell structure which can only be obtained by light passing through the object. One surface of the mirror is plane and the other is concave. The plane surface reflects parallel rays and the concave surface reflects converging rays, or concentrates the light. The plane surface is usually used where the source of light is near, and with instruments equipped with condensing lenses. The concave surface is used when the source of light is distant. It is also used when interfering objects, such as window frames or nearby buildings, partially cut off the light or are projected into view. When possible, the plane surface should be used when working with instruments equipped with condensing lenses.

The function of the condensing lenses is to concentrate the light, or bring the light rays to a focus upon the object, thus increasing the illumination of the latter. The *Abbé condenser* (named after its originator) consists of two or more modified plano-convex lenses (Fig. 21), and is attached to the microscope so that the top lens projects through the stage. The condenser mounting in modern instruments is equipped with a focusing device which permits changes

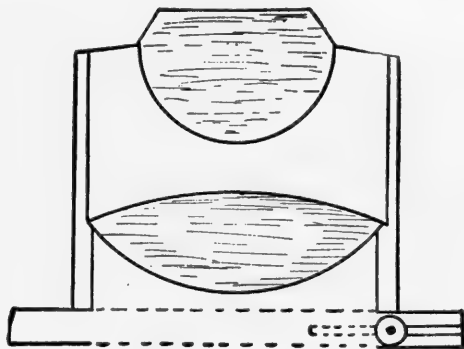

FIG. 21.-Abbé Condenser (two lens).

in the position of the focal point of the light rays passing through the condenser. In fine work, and with high powers, focusing of the condenser is essential. The usual types of Abbé condensers are not corrected for spherical and chromatic aberration. As the function of the condenser is merely concentration of light and not the production of images, these non-corrected lenses serve all ordinary purposes. In using immersion lenses one should place a layer of immersion fluid between the upper lens of the condenser and the lower

surface of the slide; otherwise much light will be lost by refraction, in passing from the condenser to the object.

The *iris diaphragm* is usually included in the condenser mounting. Although this is a mechanical device, it is so intimately connected with the working of the optical parts that it should be considered in conjunction with these. Ordinarily an excessive amount of light is projected upon the object by the mirror, and the image appears blurred. The iris diaphragm, by regulating the amount of light reaching the object, reduces this excessive illumination. While proper adjustment of the diaphragm opening is an important factor in securing clear-cut views, no absolute rule can be given for this adjustment. The size of the diaphragm opening varies with the strength of the light, the different combinations of objectives and oculars, the density of the object and the variations in the eye of the observer. Aside from the general rule that one must use larger diaphragm openings with higher power objectives, the proper adjustment of the diaphragm under different conditions must be learned by experience.

#### MECHANICAL PARTS OF THE COMPOUND MICROSCOPE

While advances in histology, bacteriology and the allied sciences have been coincident with the perfection of the optical parts of the compound microscope, improvements in the mechanical parts of the instrument have played an important part. High-power lenses demand extreme accuracy in focusing and firm, yet readily adjustable, support; therefore

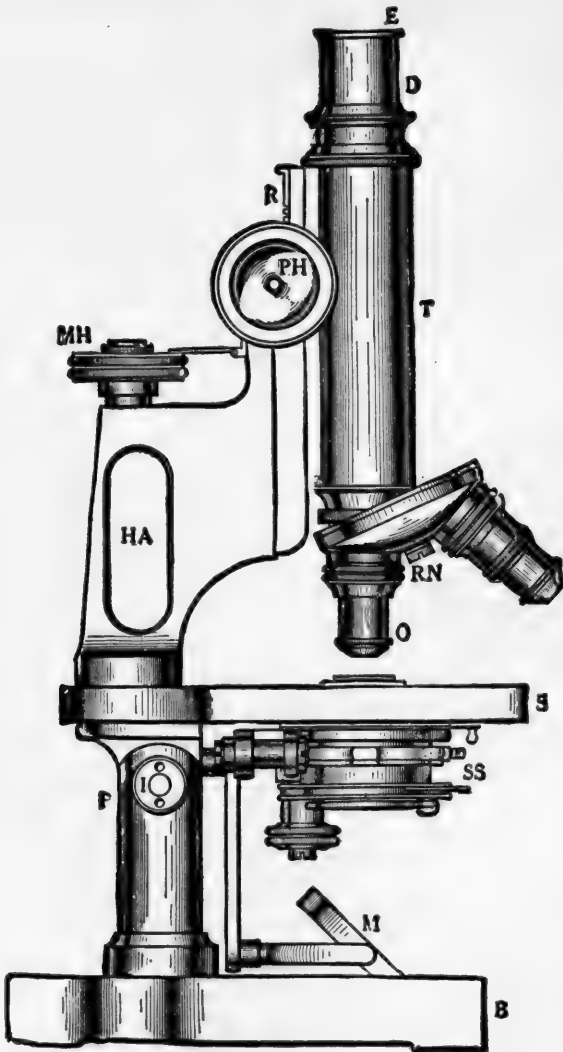

FIG. 22.—Parts of the Compound Microscope.

(Bausch & Lomb.)

*E*, Eyepiece; *D*, Draw Tube; *T*, Body Tube; *RN*, Revolving Nosepiece; *O*, Objective; *PH*, Pinion Head; *MH*, Micrometer Head; *HA*, Handle Arm; *S*, Stage; *SS*, Substage; *M*, Mirror; *B*, Base; *R*, Rack; *P*, Pillar; *I*, Inclination Joint.

the modern microscope represents optical and mechanical ingenuity of the highest order.

The microscope rests upon a horse-shoe shaped casting termed the *base*. This base, of cast iron or brass, may be hollowed out, and the cavity filled with lead, to insure greater stability. Arising from the base is the *pillar*, which is usually jointed so that the instrument may be inclined toward the worker. At a point above the *inclination joint*, the *stage* is attached. The stage serves as a rigid support for the specimen, and is perforated to accommodate the condenser. Branching from the upper part of the pillar is the *arm*, to which is attached the *tube* bearing the ocular and objectives. The tube is usually fitted with an inner tube or *draw-tube*, which may be used to vary the distance between objectives and ocular. The draw tube is usually graduated in millimeters and should be drawn out to the figure 160 (or 16) as this is the tube length for which microscope lenses are ordinarily corrected. The ocular slips into the upper end of the tube; but the lower end is provided with a circular metal plate, the *nosepiece*, with threaded collars in which the objectives fit. Nosepieces accommodate two, three or four objectives, and turn on a pinion so that the different objectives may be brought into place at the lower end of the tube. The condenser mounting, with iris diaphragm and mirror support, is usually attached to the under surface of the stage, and these devices are collectively known as the *substage*.

A microscope is fitted with two adjustments for focusing or changing the position of the tube, with relation to the specimen. The *coarse adjustment* con-

sists of two large milled wheels moving a toothed pinion which is in mesh with a rack fixed on the tube. The adjustment is used with lower powers to secure an approximate focus. The *fine adjustment* is controlled by a milled wheel placed on top of the pillar, or by small wheels one on each side of the arm. The mechanism of the fine adjustment varies in different instruments, but in all cases it is the most delicate of the mechanical parts and should be handled with due care. Turning this adjustment toward the right, or toward the microscope, lowers the tube, while turning in the reverse direction raises it. The fine adjustment is used with high-power objectives and for exact focus with the lower powers. With high power objectives the lens is very near the slide and care must be exercised in focusing with the fine adjustment, so that the objective is not forced down on the specimen. Modern fine adjustments are so constructed that when the objective comes in contact with the slide, downward motion ceases. The range of tube movement with the fine adjustment is limited, and the lower limit will be indicated by stoppage of the adjustment wheels or an automatic reversal of tube movement. Fine adjustments should not be turned more than five revolutions in either direction; and one should particularly observe this caution when working with microscopes having the fine adjustment on top of the pillar.

#### USE OF THE MICROSCOPE

To obtain good results with a microscope one must be familiar with the construction of the instrument and must pay attention to certain apparently insig-

nificant details. A regular order of procedure should be observed and should be so well in mind that it becomes more or less automatic. In this way the worker is free to devote greater attention to the examination of the specimen and less to the mechanical details of focusing and lighting.

**Position of Microscope and Worker.**—The working tables in a laboratory should be so arranged that the students can secure light from windows facing north. North light is preferred because it is less subject to variation. The instrument should be placed opposite the left shoulder and not more than four inches from the edge of the table. This permits one to use the right hand for drawing and the left for focusing or other adjustments. If one is left handed, the microscope should be placed opposite the right shoulder. Shifting the microscope further than a few inches from the edge of the table not only cuts off the light from the other students in the row, but necessitates an uncomfortable working position. Although it may be necessary to incline the instrument, better results will usually be obtained by keeping it upright. If working with temporary mounts, one must keep the microscope upright to avoid loss of the specimen. In any case the inclination should not be more than 45 degrees. If the student finds that when he sits upright his eye is below the level of the ocular, he should incline the instrument. When a microscope is carried, it should be kept upright, two or three fingers grasping the pillar below the stage. Otherwise the fine adjustment may be injured or the ocular lost.

**Lighting.**—After placing the microscope in working

position and locating the different working parts, clean the lenses with cloth (soft silk or linen) or lens paper, turn the iris diaphragm to full opening and place low power objective (No. 3 or 16 mm.) in position, 5 mm. above the stage. Turn the mirror so that it half faces the north windows and, *while looking into the ocular*, move the mirror slightly in different directions until you obtain a clear white field. After securing proper illumination, do not move the microscope or the mirror. It is better to use the plane

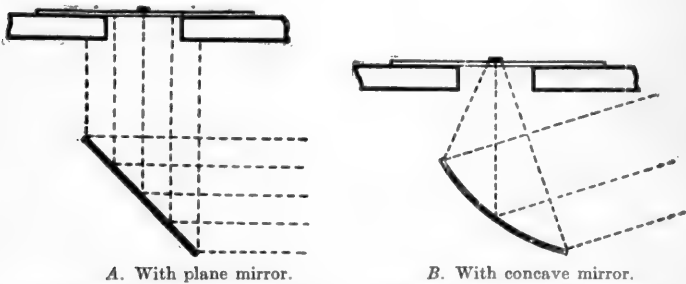

FIG. 23.—Illumination of Object by Mirror, without Condenser.

(Bausch & Lomb.)

mirror unless the light is poor. Direct sunlight should not be used for illumination, as it is so strong that it will injure the eyes of the worker.

**Focusing with Low Powers.**—After having obtained proper illumination, place the slide, cover-slip side upward, upon the stage so that the object is in the center of the condensing lens. Lower the tube with coarse adjustment so that the objective is about 3 mm. above the specimen. *Never focus downward with the coarse adjustment unless you are watching the distance between the objective and the specimen.* Slowly focus



upward with coarse adjustment until the object is visible. The distance between the end lens of the low power objective and the specimen, when the latter is in focus, should be between 6 and 10 mm. If you find that you have raised the tube more than 10 mm. above the specimen, you have probably missed the focus and should repeat the operation, taking care to focus upward *slowly*. The specimen will usually be excessively lighted, so one must decrease the diaphragm opening until the proper degree of illumination is secured.

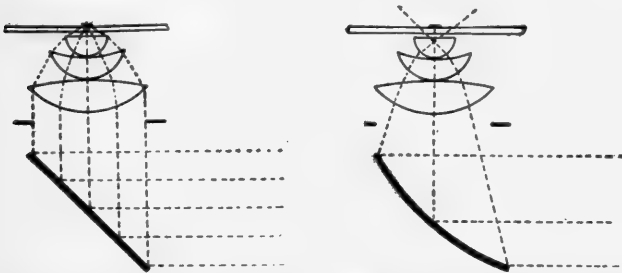

A. With plane mirror (correct way). B. With concave mirror (incorrect way).

FIG. 24.—Illumination of Object by Mirror, with Condenser.

(Bausch & Lomb.)

nation is secured. Although the specimen is visible and well lighted, the finer details of structure may not be apparent and the fine adjustment should be used to obtain a clearer view. Turn the fine adjustment in each direction not more than five revolutions until best results are obtained. It will usually be necessary to change the fine focus for different parts of the specimen and the student should keep one hand moving this adjustment. As much time is saved by placing the object in the center of the low

power field before changing to higher powers, specimens should always be located and viewed under low powers even if the high powers are subsequently used.

**Focusing with High Powers.**—Raise the tube by means of the coarse adjustment so that the objective is about 10 mm. above the specimen, and place the high power objective (No. 7, No. 8, or 3 mm.) in position. In the best instruments, the objectives are *par-focal*, or are so constructed that when one has focused the low-power objective, the other objectives may be immediately turned into position and will be in approximate focus. Adjustments must be very accurate on *par-focal* objectives and the lenses can only be used on the instrument to which they have been fitted by the maker. As the lenses of high power objectives are smaller than those of low power, and admit less light, the diaphragm opening should be slightly increased. Lower the objective, using the coarse adjustment, until it almost touches the cover-slip, then slowly focus upward until the object is visible. A final regulation of the diaphragm is usually necessary; and the student should keep focusing with the fine adjustment so as to obtain good views of all parts of the specimen. As previously stated, the lens systems of microscopes are corrected for use with a certain tube length, and allowance is made for the refractive effects of the cover-slip. Modern objectives are usually corrected so that they work best with No. 2 cover-slips, which range in thickness from 0.17 mm. to 0.25 mm. Differences in cover-slip thickness may be compensated for by varying the tube length, increasing it for covers of less than standard thickness and decreasing it for those thicker than standard.

## SUMMARY OF FOCUSING TECHNIC

*Low Powers:*

1. Adjust low-power objective (No. 3 or 16 mm.) 5 mm. above stage.
2. Arrange mirror so that clear white field is seen.
3. Place slide on stage (cover-slip upward).
4. Focus down with coarse adjustment until objective is within 3 mm. of the slide.
5. Focus upward with coarse adjustment until object is visible.
6. Regulate iris diaphragm.
7. Focus with fine adjustment to bring out details.

*Changing from Low to High Powers:*

1. Locate object with low power and place it in the center of the field.
2. Focus upward with coarse adjustment until objective is about 10 mm. above slide.
3. Turn high power objective into place.
4. Increase the diaphragm opening.
5. Focus downward with coarse adjustment until objective is about 1 mm. above the slide.
6. Focus upward with fine adjustment until specimen is apparent.
7. Regulate iris diaphragm.

*Cautions:*

1. Never focus downward with coarse adjustment while looking in the microscope.
2. Do not turn the fine adjustment more than five revolutions in either direction.
3. Do not change from low-power to high-power objective without previously raising tube.
4. In case of accident do not attempt repairs or replacement.

**Use of the Eyes.**—Contrary to popular opinion, microscopical work is not injurious to the eyes. However, certain precautions must be observed to prevent discomfort and strain. Both eyes should be kept open, as the strain of squinting soon causes headache or tires the eye muscles. By keeping both eyes open, one eye is available for observation of the specimen and the other for transcribing the image to paper.

For a few minutes, there will be difficulty in keeping both eyes open and in concentrating so that one obtains a clear picture with the eye used for observation, but this difficulty is very soon overcome. Still more difficult, but equally necessary, is the ability to use each eye for observation and to be able to change rapidly from one to the other. The proper distance of the eye from the ocular varies with oculars of different powers. The eye-point for low-power oculars is at a greater distance from the eye lens than is the case with those of high power. Cleanliness of lenses and specimens, together with the proper regulation of light, are important factors in saving the eyes from undue strain.

**Cleaning the Microscope.**—Dust particles and finger marks cause serious difficulty and annoyance in working with a microscope. These foreign materials are magnified just as much as the specimen and thus result in indistinct images. Finger prints upon optical parts are a sure sign of the careless worker, and as they are easily avoided are all the more aggravating. Slides and cover-slips should always be handled by their edges, and the lens surfaces should never be touched with the fingers. Finger prints may be removed by breathing upon the surface showing them, and quickly wiping it dry with cloth or lens paper. Old smears not yielding to this treatment may be removed with a cloth sparingly moistened with alcohol or xylol; but the solvent must not be allowed to penetrate the lens mounting. Dust particles on lenses may be removed with a camel's hair brush or dry soft cloth. By rotating the condenser, objective and ocular, the position of dirt or other interfering

materials may be readily located. Cloudiness, especially upon the cover-slips of glycerin jelly mounts, may be due to moisture, which may be removed with a cloth moistened with alcohol. Dust on mechanical parts is best removed with chamois or dry cloth. Bearings and moving parts may be cleaned and lubricated by wiping with a mixture of gasoline and light machine oil. Fine adjustments are usually packed with petrolatum. Solvents should not be allowed in contact with lacquered parts. Discoloration of the



A. With diaphragm open.

B. With diaphragm partly closed

FIG. 25.—Air Bubbles.

stage may be remedied by thorough washing and drying, followed by light application of paraffin oil all excess being removed by rubbing.

**Interpretation of Images.**—In viewing an object through the microscope one must remember that the image is inverted or reversed. Consequently, if one moves the slide toward the right, the object as viewed in the microscope will apparently move toward the left. If you desire to shift an object from the edge to the center of the field, move the slide in the opposite

direction. In working with temporary mounts the specimen should be allowed to stand for a few minutes before observation, as diffusion currents in the liquid cause rapid motion of the specimen. When viewing very small objects in temporary mounts, one will observe that they are in constant motion. This phenomenon is termed *Brownian movement*, and is exhibited by fine particles of solid materials in suspension or colloidal solution. In examining specimens having a curved or irregular surface, one must make full use of the fine adjustment so as to gain clear views of the elevations and depressions in the specimen. The novice will often mistake air bubbles for cells or cellular material; but their behavior upon opening and closing the diaphragm serves to identify them. If, while looking at an air bubble, one closes the diaphragm opening, the wall of the bubble will increase in thickness, and if the diaphragm is opened, the wall will become thinner (Fig. 25). The walls of cellular elements are not affected in this way by the opening of the diaphragm.

**Drawings.**—The representation of microscopic images may be accomplished by photography, by the use of mechanical accessories and by free-hand drawing. The apparatus necessary for microphotography consists essentially of a microscope to which is attached the bellows and shutter of a camera (Fig. 26). Separate lenses for the camera are not used, as the ocular serves to project the image. While microphotographs give exact representations of the object, they are not suited for many purposes or for many classes of specimens. The object must be specially prepared and one cannot, as is sometimes desirable, give promi-

nence to one part of the specimen and repress others. It is difficult to combine in one photograph structures found in different fields. Mechanical accessories for delineation of microscopic images are far more useful than the microphotographic apparatus. The essential parts of the mechanical apparatus are a prism and a mirror so placed that the image produced by the ocular will be reflected upon a drawing surface. The reflecting device is so constructed that the worker may observe the specimen and at the same time see the drawing surface. The apparatus is termed a *camera lucida* and is more carefully described in a subsequent chapter. With the camera lucida one can obtain drawings in which relative proportions are preserved, may combine in one drawing objects seen in different fields and may emphasize certain structures and ignore others.



FIG. 26.—Microphotographic Apparatus.  
(Bausch & Lomb.)

Free-hand drawing of microscopic images requires

patience and an aptitude which can only be acquired by practice. While natural talent for drawing is an advantage, it is not absolutely essential, and those not so talented will often produce more exact sketches. In sketching both eyes must be kept open and one eye should be at the microscope while the other is focused on the paper. Various parts of the specimen should be examined and only the clearest objects should be selected for drawing. One seldom finds satisfactory fragments of different tissues in a single field, and it is therefore necessary to explore a number of fields, selecting suitable materials from each and combining all in one drawing. Having decided upon the part of the specimen to be drawn, one should roughly plan it out on paper so that all parts of the object will be in proper relation both as regards size and position. The outlines should then be sketched in and finally light shading may be employed to indicate contrasts in depth of color. Particular attention is directed to the following points:

1. Each cell is entirely surrounded by a cell wall, and this is unbroken unless the specimen has been injured in preparation. In representing cell walls the lines should be continuous and should be brought back to the starting point.
2. A cell wall has a certain thickness and this must be represented by surrounding the cell with a double line or a single line of substantial width.
3. Cells rarely appear as exact geometrical forms (circles, squares, oblongs, etc.) although they may closely approach these. There are slight but distinct differences between cells, even though they are adjacent. In a drawing, each cell should be fitted to the others in the tissue and the slight differences in shape and size should not be overlooked.



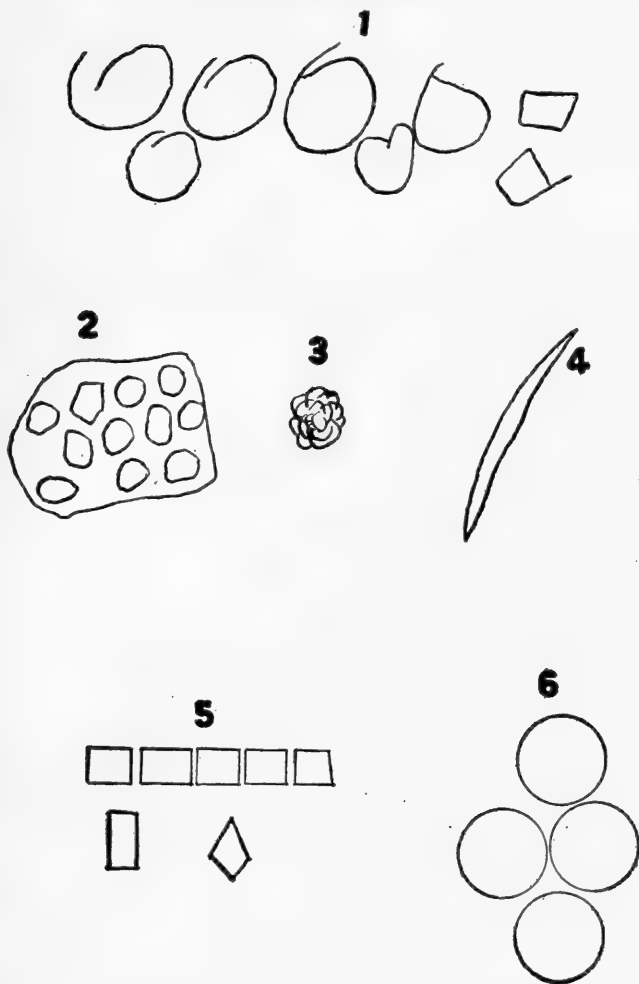

PLATE 27.—Common Errors in Sketching.

1. The cell walls of these parenchyma cells should be continuous and should be brought back to the starting point. 2. The cells in this fragment of tissue should be surrounded by a cell wall of definite thickness and the space between the cells is much exaggerated. 3. The parts of this aggregate crystal (rosette type) are sharp pointed and not rounded as illustrated. 4. The sides of this crystal should be straight lines as acicular crystals are never curved. 5. These cork cells are too symmetrical in form. There are slight differences between individual cells and these are not represented. 6. Parenchyma cells never appear as exact geometrical forms.

Broken or sketch lines should not be used, and heavy shading should be avoided. Each drawing should bear the name of the material from which the slide has been prepared. The particular structure which the drawing is intended to illustrate should be noted in connection with the sketch.

## CHAPTER IV

### THE CHEMICAL REACTIONS OF PLANT TISSUES

THE minute details concerning the composition of cell walls and cell contents are often of great academic interest, although the microanalyst depends more upon structures than upon specific chemical reactions. However, there are instances when these reactions are of practical value. Certain complex organic substances occur in all plants either in the cell walls or the cell protoplasm. Variations in the amounts or combinations of these compounds materially influence the structure of different tissues. While the original walls of the embryo cells are thin and consist largely of cellulose, when the plant assumes an independent existence other substances are deposited or added to this cellulose wall with consequent thickening or other changes in appearance. In dealing with the chemical constitution of plant tissues it is convenient to consider the relations of the cell apart from those of the cell contents. This is all the more desirable because the compounds present in cell walls are relatively few as compared with those possibly present in the protoplasm and those which result from the physiological activity of the latter.

### CHEMICAL PROPERTIES OF CELL WALLS

The walls of primitive cells are usually composed of cellulose; but in the building up of more complex structures the cell walls undergo more or less change in chemical composition as well as in appearance. The substance most frequently occurring in the cell walls are cellulose, lignin, cutin, suberin and gums, including pectinous substances. Many of the aniline stains give characteristic colorations with these substances, and these reactions will be considered in the section on Staining.

**Cellulose.**—This is a carbohydrate to which the empirical formula  $(C_6H_{10}O_5)_x$  has been assigned. The following reactions may be used in the identification of cellulose:

1. A blue coloration with iodine and sulphuric acid. Treat the material with iodine-potassium iodide solution, then add a few drops of sulphuric acid (70 per cent).
2. A violet coloration with zinc chloriodide solution.
3. Solubility in cuprammonia solution.

**Lignified Walls.**—Lignification of cell walls, or deposition of woody materials upon the cellulose membrane, occurs in those tissues of the plant which are used for support. The existence of a definite substance termed *lignin* is open to question, and it is possible that the reactions given by lignified walls may be due to one or more compounds present in woody materials. The following reactions may be used in the identification of lignified tissues:

1. A yellow or brown coloration with iodine and sulphuric acid.
2. A yellow or brown coloration with zinc chloriodide solution.
3. A red or violet coloration with phloroglucin solution and concentrated hydrochloric acid.

**Cutinized and Suberized Walls.**—The substance *cutin* occurs in the epidermal tissues, especially in those of the green parts of the plant. These cutinized walls form a thin, transparent, waterproof membrane or covering tissue, which protects delicate structures from injury and excessive evaporation of water. As the plant matures the epidermal tissues are gradually replaced by cork, which contains the substance *suberin* in the walls of its cells. Cork or suberized cells protect the mature plant against temperature changes and mechanical injury. Cutinized and suberized cell walls give similar reactions with most reagents and for differentiation we must depend upon structure and location rather than upon chemical properties. The following reactions are chiefly of use in distinguishing between cellulose or lignin and cutin or suberin:

1. Concentrated potassium hydroxide solution (30 per cent) produces a yellow to brown coloration in suberized walls.
2. Concentrated alcoholic chlorophyll solution, acting in the dark, stains cutinized and suberized walls green, but does not affect cellulose or lignified walls.
3. Alkannin solution colors cutin and suberin red.

**Gums and Pectinous Substances.**—The cell wall in certain plants is so modified in its chemical nature that the original cellulose has been more or less replaced by substances which, in contact with water, behave like the gums and form mucilages. It may be that the *gummosis* occurring around wounds in certain plants is an effort to prevent injurious substances from reaching vital parts. However, gums are occasionally found in seeds apparently well protected from injury by tough coats. As the gums are complex chemical

substances and in some instances appear to be mixtures, definite reactions can seldom be given. Pectins or mixtures of pectic substances are widely distributed in the cell walls of fruits. This substance is responsible for the hardening or "jelling" of fruit jellies.

1. The fact that gums swell when brought into contact with water is of value in demonstrating the presence of these substances in the cell wall. The material should be mounted in absolute alcohol and the water gradually added.
2. Pectic substances are best identified by their reactions with various aniline dyes. Fuchsin, methylene blue and Bismarck brown stain pectic materials as well as lignin and suberin; but the latter substances retain the color after treatment with alcohol or acids, whereas the pectic substances are decolorized by this treatment.

#### CHEMICAL PROPERTIES OF CELL CONTENTS

The protoplasm, or material within the wall of a vegetable cell, contains structures concerned in the physiological activity of the cell together with *inclusions*, or substances produced by this protoplasm. The term *cell contents* might be used for all materials within the cell wall, thus including such physiological parts as the nucleus and vacuoles, together with starch, inulin and other inclusions. However, in vegetable histology the term *cell contents* is restricted to materials resulting from the activity of the protoplasm and would therefore include starch grains, calcium oxalate crystals and other substances. These inclusions, or non-protoplasmic cell contents, may be inorganic or organic substances. They are most conveniently subdivided into substances of definite form and those of indefinite form. The histology of the various cell contents will be considered in a subsequent section but their chemical

properties are briefly noted under the following headings.

**Starch.**—The empirical formula assigned to starch is  $(C_6H_{10}O_5)_x$ ; but there are differences of opinion as to whether the starch grain is homogenous in structure and whether it is a simple substance or a mixture. Starch is the most widely distributed of all the materials classed as cell contents, and in amount exceeds all others. Starch grains swell, upon the addition of boiling water, and form a pasty mass. Complete solution of the grains is not effected unless they are treated with superheated steam. Solutions of alkali hydroxides even at moderate temperatures cause formation of a paste with swelling of the grains. Roasting transforms starch to dextrins which are more or less soluble in water. The following reaction is used in the identification of starch:

1. Addition of dilute aqueous solution iodine-potassium iodide colors starch grains blue. Heating causes a disappearance of the color, but it reappears upon cooling. Very characteristic results may be obtained by the addition of chloral hydrate solution to specimens previously treated with the iodine solution. The chloral acts as a clearing agent, destroys many of the cell contents and finally causes swelling and disintegration of the starch grains.

**Inulin.**—Inulin has the same empirical formula as starch and occurs in solution form in plant tissues. It can be precipitated in plant cells by the addition of alcohol, but dissolves readily upon the subsequent addition of water. The following reaction may be used in the identification of inulin:

1. Addition of aqueous iodine-potassium iodide solution colors inulin deposits brown.
2. Pyrogallol solution colors inulin violet red.
3. Acetic acid dissolves inulin, producing a greenish solution.

**Sugars.**—The chief sugars found in plants are glucose, levulose and sucrose (cane sugar). The empirical formula for glucose and levulose is  $C_6H_{12}O_6$ , while that of sucrose is  $C_{12}H_{22}O_{11}$ . The sugars occur in solution in the living plant tissues and like inulin, they may be precipitated by the addition of alcohol. The general reactions for the identification of sugars in plant cells are as follows:

1. Addition of alpha-naphthol solution, followed by a few drops of concentrated sulphuric acid, yields a violet coloration. Inulin also responds to this test.
2. Treat the material with copper sulphate solution (20 per cent), wash, add alkaline Rochelle salt solution (potassium hydroxide 10 gms., Rochelle salt 10 gms., in 100 mils of water) and boil. Cuprous oxide will be precipitated in cells containing sugars and will appear black by transmitted light and red by dark field illumination.
3. Many sugars form characteristic crystalline osazones upon treatment with phenylhydrazine in the presence of acetic acid. The sections should be boiled for at least one hour with the phenylhydrazine solution and then rapidly cooled. Unless thick sections are employed the sugars will be dissolved in the reagent and the precipitate will form at the bottom of the liquid rather than in the individual cells. The phenylhydrazine solution is prepared according to the formula noted in the Appendix.

**Alkaloids.**—Alkaloids are basic compounds containing carbon, hydrogen, nitrogen and oxygen, although the latter element is wanting in the liquid alkaloids. Their toxic effects upon animals and plants are of great interest, and the salts of these alkaloids are among the most important items in our *materia medica*. The alkaloids, being basic in reaction, readily form salts with the acids present in the plant cells, and these alkaloidal salts present in the plant are usually in solution. The microchemical reactions of



alkaloids are often complicated by interfering substances which seriously impair the value of tests. The general test for alkaloids in plant tissues are as follows:

1. Mercuric-potassium iodide solution causes the formation of a yellowish flocculent precipitate with most alkaloids.
2. Iodine-potassium iodide solution yields reddish or brownish precipitates with nearly all alkaloids.
3. The alkaloids of *Hydrastis* may be precipitated *in situ* by mounting freshly cut sections in sulphuric acid.

**Glucosides.**—The glucosides are plant principles which, when decomposed by dilute acids or enzymes, yield sugar (chiefly glucose) as one of the products of the reaction. Aside from this property of yielding glucose upon decomposition there are no group reactions which may be used in their identification. A few glucosides have the property of reducing copper sulphate directly, or without apparent decomposition and subsequent production of glucose. Many of the glucosides, upon hydrolysis or decomposition, yield sugars which give characteristic crystalline precipitates with phenylhydrazine.

**Calcium Oxalate.**—The great majority of crystals occurring naturally in plants are composed of calcium oxalate. This substance crystallizes either in the monoclinic or in the tetragonal system, but the crystals naturally occurring in plants are rarely symmetrical. In many plants the calcium oxalate occurs in small broken crystals termed *crystal sand*. The tests for calcium oxalate are as follows:

1. Nitric and hydrochloric acids dissolve the oxalate crystals.
2. Concentrated sulphuric acid causes destruction of the oxalate, resulting in the formation of insoluble needle crystals of calcium sulphate.

**Aleurone.**—Aleurone is a protein or nitrogenized principle found in many seeds, especially those rich in fixed oil. Except in the cereals it seldom occurs associated with starch. Aleurone is present in the form of granules surrounded by a membrane enclosing a protein substance, in which are embedded globular particles (globulins) and calcium oxalate crystals (crystalloids). Very little is known regarding the exact composition of these proteins and their formation in the plant. The general tests for aleurone and other plant proteins are as follows:

1. Iodine-potassium iodide solution colors proteins yellow to brown. The iodine solution should be more concentrated than that used in the test for starch.
2. Concentrated nitric acid colors proteins bright yellow (xanthoproteic reaction).
3. Millon's reagent gives a bright red color upon warming the material to which the reagent has been applied.

**Tannins.**—The tannins are a group of chemically allied substances chief among which are tannic and gallic acids. In the living plant they occur in solution or as amorphous deposits. Tests for tannins in vegetable materials are as follows:

1. Ferric chloride solution gives a bluish or greenish black coloration, depending upon the particular tannin compound present.
2. Cupric acetate solution produces a reddish brown precipitate with tannins.

**Resins.**—The resins include a complex group of substances which are found in many plants. In a number of instances volatile oils or gums are associated with these resins thus forming *oleoresins* and *gum resins*. Owing to the great variation in chemical composition and the scarcity of definite information

upon the resins, there are no general microchemical tests for this group. Resins are generally soluble in volatile solvents and, like the fats, give a red coloration with alkannin solution.

**Silica.**—Silica, silicic acid or silicon dioxide may occur as deposits upon the walls of cells or in the form of rounded masses. This substance is only soluble in hydrofluoric acid and is not destroyed by heating at high temperatures.

**Calcium Carbonate.**—Calcium carbonate occurs free in the plant cells, as deposits upon the cell walls, or in the form of irregular masses attached to the cell wall by a slender filament of cellulose.

1. Addition of concentrated hydrochloric acid dissolves deposits of calcium carbonate with the evolution of gas bubbles (carbon dioxide).

**Fats.**—The fats and fixed oils are organic salts of the so-called fatty acids, chiefly palmitic, stearic and oleic acids. They usually occur in the form of globules within the living cells of seeds and fruits. They are rarely associated with starch but often occur in seeds containing aleurone. The microchemical tests for oils and fats are as follows:

1. Addition of alkannin solution colors fat and oil globules bright red. Suberized walls are also colored red by this reagent.
2. Boiling with concentrated potassium hydroxide solution or strong ammonium hydroxide causes saponification which is evidenced by a loss of refractive power in the globules. Upon cooling, the globules are found to be covered with small needle crystals of soap.

## CHAPTER V

### STAINING

THIN sections of light-colored specimens, especially those prepared by the infiltration method, are apt to be so transparent that the details of structure are almost invisible. This difficulty is overcome by coloring or staining the sections with various dye-stuffs. The staining process is either a saturation of the cellular material with the color, or a chemical reaction between the stain and the compounds contained in the cell. In the latter instance the stain plays the part of a reagent. As a rule the nuclear material stains more readily than the other parts of the cell; therefore upon the application of a *saturation* or *general stain*, the nucleus will always appear more deeply colored than the surrounding parts.

With comparatively few exceptions the stains in use are aniline colors and are kept in the form of saturated alcoholic solutions. These solutions should be kept in glass-stoppered bottles in a dark cool place. The staining solutions are prepared by diluting 5 mils of the alcoholic solution with distilled water, to make 100 mils. If sections are in aqueous media and not attached to slides, they may be stained by placing them in a shallow dish filled with the stain. If the sections are dehydrated, whether attached to slides or free, they must be rehydrated as directed in a previous chapter.

The time required for staining varies with the material and the stain employed, and proper conditions can only be determined by experiment. The general statement may be made that most vegetable sections will be sufficiently stained in ten minutes. For ready manipulation of specimens attached to slides there are several forms of special staining jars available. These jars have a decided advantage in that the slide is placed on edge during the staining process, thus avoiding deposition of foreign materials. They are also economical in that less staining fluid is required. These jars are usually provided with covers and may be used as laboratory containers for stains in frequent use. In many instances better results and more exact control may be had by overstaining and subsequently washing out the excess stain with dilute alcohol.

Combinations of two or more stains may be used for the purpose of obtaining differences in color in different parts of the cell. This process is termed *double staining*. Double staining may be effected by using combinations of different dyes in one solution or by using a separate solution of each stain. Certain cell substances, notably those of many micro-organisms possess the power of retaining the stain after immersion in dilute hydrochloric or sulphuric acids. This firm combination of stain and cell substance is termed *acid-fast*. Although this character is of minor importance in vegetable histology it is of great value in differential work on organisms. Specimens should be well rinsed in water after all staining procedures.

**Stains for Cell Walls.**—Differences in chemical composition of cell walls and contents are rendered

more apparent by the application of reagents and stains. The color changes incidental to the action of reagents are due to chemical interaction, whereas with stains the coloration is usually due to a saturation of the cellular material with the dye. It is noted that certain tissues color easily with a given stain, while others are indifferent to its action. Certain stains may thus be used to differentiate cellular elements and contents from others closely resembling them. Stains used for this purpose are termed *differential stains* in contradistinction to *general stains*, which color most, if not all tissues. The effects of differential stains are somewhat analogous to the actions of reagents. Formulæ for the staining fluids recommended in the following notes will be found in the Appendix.

*Cellulose:*

Delafield's hematoxylin:

Cellulose walls are colored violet. The time required is five to fifteen minutes.

*Lignified Tissues:*

Delafield's hematoxylin:

Lignified walls are colored yellow to brown. The time required is at least thirty minutes and generally longer, depending upon the texture of the material.

Fuchsin:

Lignified walls are stained deep red. Aqueous solutions are used and the time required is fifteen to thirty minutes. Best results are obtained by washing the stained material for five or ten minutes in Altman's picric acid solution.

*Cutinized and Suberized Tissues.*

Cutinized cell walls stain slowly and with difficulty. Cyanin, saturated solution in 50 per cent alcohol, stains cutinized membranes deep blue. The time required is at least twenty-four hours.

Aniline water safranin stains suberized walls yellowish and lignified walls blue. Allow the stain to act for a least thirty minutes, wash in acid alcohol, then in alcohol, until washings are colorless.

*Gums.*

Mucilaginous cell walls do not stain satisfactorily.

*Pectins.*

Fuchsin stains pectic substances, lignified tissues and suberin deep red. Upon washing the stained specimens with acid alcohol, the pectic substances are decolorized while lignin and suberin retain the color. The time required is between fifteen and thirty minutes.

## CHAPTER VI

### THE PLANT CELL

**General Considerations.**—The fact that a plant is an aggregation of small bodies or cells was first brought to general attention in 1667 by Robert Hooke, an English lens manufacturer. This discovery was merely incidental to the attempts then being made to improve the crude lenses of the time; and Robert Hooke used plant sections merely as demonstration objects. Grew and Malpighi, working independently, confirmed Hooke's observations, and their published researches are the earliest records of work upon the cellular structure of plants and animals. All living bodies are composed of one or more small units or cells. The simplest organisms consist of but one cell (*unicellular*), all functions necessary to the life and continuance of the species being performed by this individual unit. The more complex organisms begin life as a single cell, but this unit rapidly undergoes division and forms a *multicellular* individual. In the unicellular organism all life processes are performed by a single cell; but, fairly early in the development of multicellular plants and animals, there occurs a differentiation of cell structures resulting in the formation of tissues. A *tissue* is a group of cells of similar structure and is designed to perform a certain work for the organism. The work that a tissue performs



is termed its *function*, and the existence of a multicellular organism is dependent upon the proper functioning of its component tissues.

**Cytology**, or the study of cells, reveals many structures within each cell, and it is customary to consider a cell as consisting of a cell wall and the protoplasm, or material within this wall. The study of cell walls

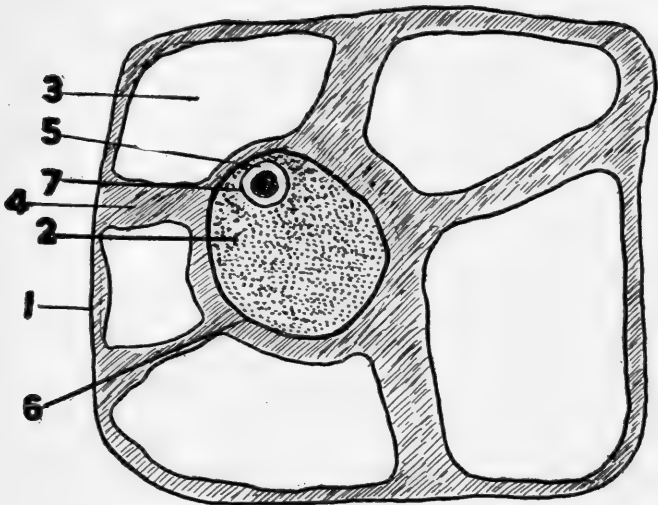

PLATE 28.—Plant Cell from *Tradescantia* Stem.

1. Cell wall. 2. Nucleus. 3. Vacuoles. 4. Cytoplasm. 5. Nucleolus.  
6. Nuclear membrane. 7. Nucleolar membrane.

and their modifications is a subject of great importance in that part of vegetable histology dealing with the microanalysis of foods and drugs. The *protoplasm* is a semi-solid substance in which the presence of several structures, or cell contents, can be demonstrated by proper treatment (Plate 28). These structures may be classified as *protoplasmic contents*, or

those responsible for the life of the cell, and the *non-protoplasmic contents* or *inclusions*, substances resulting from the activity of the protoplasmic contents. The protoplasmic contents include the *nucleus* and *chromatophores* or *plastids*. The nucleus is separated from the protoplasm by a thin membrane and contains a granular substance termed *chromatin*, together with delicate thread-like structures termed *linin threads* and one or more spherical bodies termed *nucleoli*. The chromatophores are small bodies embedded in the protoplasm and are of importance in the manufacture of the non-protoplasmic contents. According to location and specific function, the chromatophores are colored (*chromoplastids*) or colorless (*leucoplastids*). The green color of leaves is due to the presence of green *chromatophores* or *chloroplastids* and, as will be noted in a subsequent section, these are directly concerned in the production of starch by the plant. The position occupied by the nucleus in plant cells, and the appearance of the protoplasm depend upon the age of the cell. In newly formed cells, or those in parts of the plant where growth is active, the nucleus is in the center of the cell and the latter is entirely filled with protoplasm. In mature plant cells, or those located in parts of the plant not active in growth, the protoplasm undergoes shrinkage and cavities or *vacuoles* are formed. As the cell grows older and less active, the vacuoles increase in size until the remaining protoplasm is merely a narrow strip in contact with the cell wall. The vacuoles are rapidly filled with a liquid termed *cell sap*, which is of importance in the distribution of nutrients to the growing portions of the plant. The nucleus always remains embedded

in the protoplasm, and when the latter has been reduced to a layer in contact with the cell wall the nucleus will be moved toward this wall. In very old cells, such as the wood in the center of a tree, all traces of protoplasmic contents are lost and the cells are in reality dead. The walls and cavities of these dead cells perform important functions as supporting and transporting elements.

The non-protoplasmic contents or inclusions comprise a large number of substances and these show great variation both as regards chemical composition and structural character. A majority of plants contain starch, a typical inclusion; but the granules of starch in different plants show material differences in structure. The non-protoplasmic contents include alkaloids, enzymes, starch, glucosides, sugars and fats. In dealing with foods and drugs one seldom encounters the nuclei or other protoplasmic contents; therefore in microanalysis the term cell contents is generally applied to the non-protoplasmic cell structures.

**Structure of the Cell Wall.**—The walls of growing cells are mere membranes composed of the substance *cellulose*, but after attaining full growth the cells require a stronger covering, and this is obtained by a thickening of the original membrane. Thickening of a cell wall may be accomplished by the deposition of successive layers of cellulose or other materials outside the original membrane, or by the introduction of substances between layers of cell wall already formed. Thickening by deposition is the usual method and is termed growth by *apposition*. Introduction of substances between layers of wall is termed growth by *intussusception*. In growth by apposition the different

layers may be clearly marked or may be so consolidated that but a single wall is apparent. Growth by intussusception is often apparent in walls which show thickenings at certain points and not at others. Although the primitive cell membrane is composed of cellulose, this substance is usually replaced by other materials during the process of growth in the wall. Lignified cell walls are those in which a woody substance has been deposited upon the cellulose membrane. Suberized cell walls are found in cork cells, and result from the deposition of suberin upon the cellulose. Cutinized walls occur in the covering membranes of leaves where the original cellulose has been replaced by cutin.

#### ORIGIN OF CELLS AND TISSUES

Every plant, unicellular or multicellular, is the direct descendant of a preceding generation. In the lower forms of plant life the production of new cells is often a comparatively simple process and consists in a direct division of the nucleus followed by the formation of a wall between the divided nuclei. The wall between the cells is formed by a constriction of the original cell wall and an inward projection of the latter, until the newly formed cell is separated from the parent cell. In the higher forms of plant life the process of cell division is extremely complex and is termed *mitosis* or *indirect nuclear* division. Mitosis, like the direct method of cell reproduction, consists essentially in a division of the nucleus followed by the formation of a cell wall between the separated nuclei, but differs in the manner in which the nuclear division

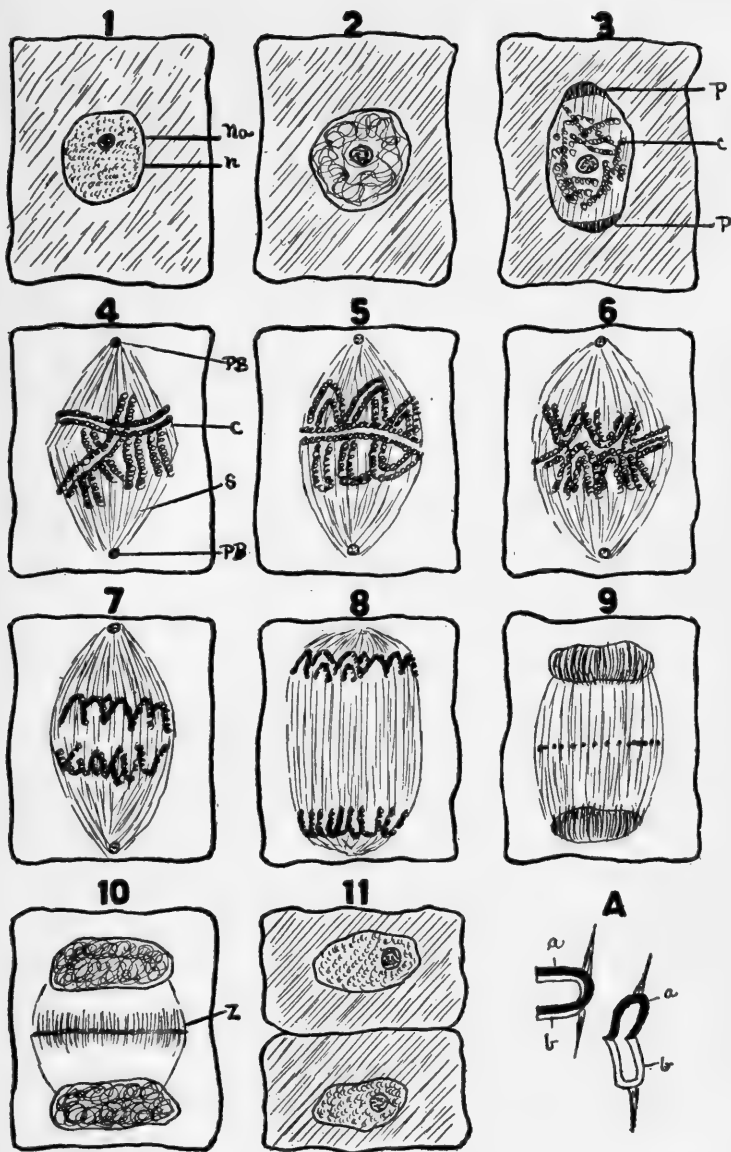

PLATE 29.— Changes in a Cell During Mitosis. (Modified from Strasburger, Noll, Schenck, Karsten, "Text Book of Botany".)

*No*, Nucleolus. *N*, Nucleus. *P*, Polar caps. *C*, Chromosomes. *PB*, Polar bodies. *S*, Spindle fibers. *Z*, Cell plate. *A*, Separation of chromosome loops by traction fibers of the spindle. *a* and *b* are halves of a chromosome loop.

is accomplished. The details of mitosis or indirect nuclear division are but briefly described in the following statements. The network of linin threads is unraveled into a definite number of semicircular filaments each of which is covered with chromatin bodies. These filaments are now termed *chromosomes* and are so arranged that the curved portion of each is toward the center of the nucleus. *Centrosomes* or attraction bodies are established at opposite sides of the nucleus, forming slight thickenings termed *polar caps*. A series of delicate fibers extends between the polar caps. A second series of fibers are attached to opposite sides of the chromosomes, each of which has previously begun to separate longitudinally. Contraction of this second set of fibers completely separates each chromosome into two segments. The individual segments representing a single chromosome are drawn toward opposite polar caps. The group of chromosomes at each polar cap becomes invested with a membrane and each group forms the nucleus of a cell. Formation of walls to surround the cells, of which each of these nuclei form the center, begins when the chromosomes are in the center of the old nucleus. The forerunner of the new cell wall is formed at certain points by a thickening of the fibrils extending between the polar caps. These thickened portions form a structure which extends across the cell and which is ultimately covered by layers of cellulose produced by the cells which have just undergone division. The new cells are furnished with chromoplastids by direct division of these present in the parent cell.

## PLANT TISSUES

Immediately upon fertilization of the egg-cell contained in the ovule, multiplication of cells by the process of mitosis occurs, and an embryo is formed. In the earliest stages of embryo formation the cells produced by indirect division are alike in structure, but a differentiation of cells soon occurs in the development of the embryo. This differentiation ultimately results in the formation of tissues, or groups of cells having specific characters. As previously noted, each tissue has a certain function and is particularly fitted to perform this function by certain peculiarities in the structure of its cells. In the young embryo practically all the cells are capable of division; but in the mature plant this property is present in comparatively few cells and these form the *meristematic tissues* located at the growing points of stems and between the bark and wood. The young embryo may be divided into three zones of undifferentiated cells, an outer or *dermatogen region* from which the first covering tissues of the plant are derived; a middle or *periblem region* from which the covering tissues of the mature plant are derived; and a central or *plerom region* from which all other plant tissues are derived. Each of these zones (Plate 30), contains meristematic cells which soon produce primary tissues showing differences in structure and contributing to the rapid development of the young plant.

**Primary Root Tissues.**—Differentiation of the fundamental tissue of the dermatogen, periblem and plerom zones results from changes in the character of the cell walls and from the activity of meristematic

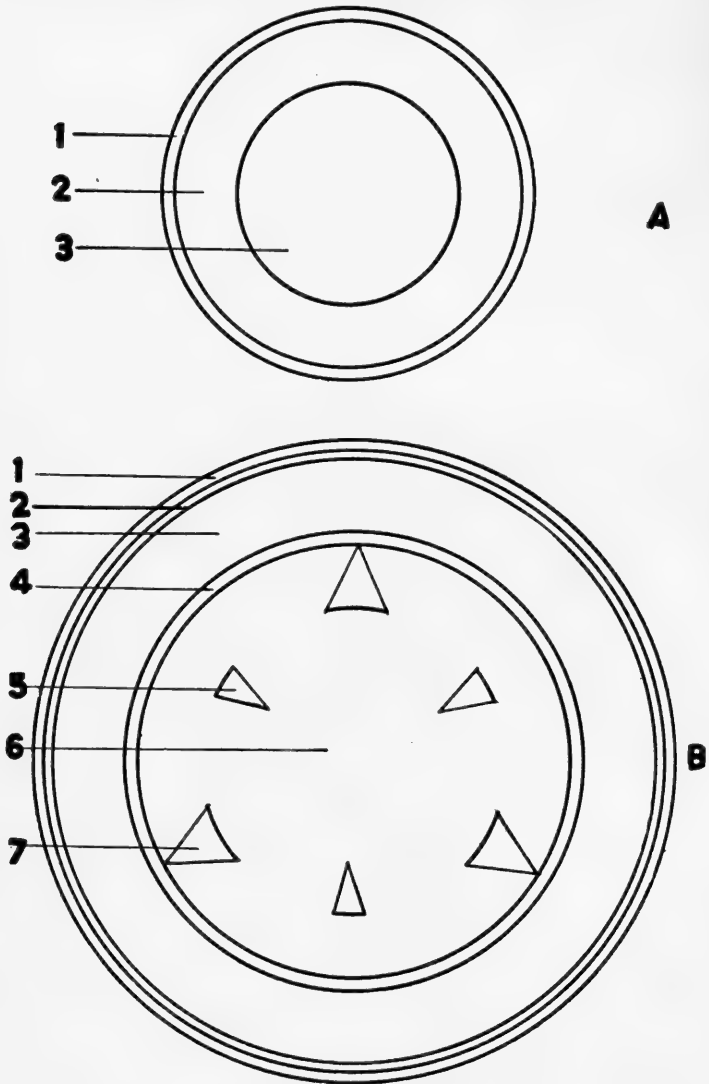

PLATE 30.—A. Arrangement of the Fundamental Tissue Layers in a Root and Stem.

1. Dermatogen zone. 2. Periblem zone. 3. Plerom zone.

B. Arrangement of the Primary Tissues in the Root.

1. Epidermis. 2. Hypodermis. 3. Primary Cortex. 4. Endodermis. 5. Xylem bundle. 6. Pith. 7. Phloem bundle.



regions. In the dermatogen zone of the root, three distinct primary tissues are usually apparent. The outer layers of cells at the tip of the root form the root cap and are rather thick-walled. This root cap serves to protect the more delicate structures from injury through contact with sharp particles of soil. The epidermal cells above the root cap give rise to root hairs which are of importance in the absorption of materials from the soil. The *root hairs* are modified epidermal cells and appear as thin-walled projections from the latter. Portions of the root above those clothed with root hairs are covered with rather thick-walled epidermal cells termed the *primary epidermis*. In the periblem zone of the root, three primary tissues are present. The layer or layers of cells adjacent to the primary epidermis constitute the *hypodermis*. The hypodermal cells are usually angled and thick-walled. The layer of cells adjacent to the perom zone is termed the *endodermis*. Endodermal cells are usually thick-walled and bear a close resemblance to those of the hypodermal layer. The several layers of cells between the hypodermis and the endodermis are termed the primary cortex or *cortical parenchyma*. Cortical parenchyma cells represent the original periblem tissue and show little if any differences in structure from the latter. The most striking changes in character of cell wall due to development occur in the perom region. Certain groups of cells in this region acquire thickened walls through deposition of lignin, and thus form the *prosenchyma* or fibrous elements which give strength to the plant. Conducting elements or *ducts* are developed in the midst of these lignified cells. Each group of lignified cells,

together with the associated ducts, is termed a *xylem bundle*, and these bundles may be arranged in a definite order in the plerom region. Lignification of cell walls also occurs in groups of plerom cells other than those of the xylem bundles; but the conducting elements developed in these other lignified groups differ from the ducts in that they are not continuous. They are termed *sieve tubes*, because communication between the various cells is through perforated walls. Each group of sieve cells, with its associated lignified tissue, is termed a *phloem bundle*, and these, like the xylem bundles, may be arranged in a definite order. The lignified cells of a xylem bundle are termed *wood fibers*, while those in the phloem bundles are termed *bast fibers*. As each xylem or phloem bundle consists of a fibrous element and a vascular or conducting element, the term *fibro-vascular bundle* is applied to the combination. The xylem and phloem bundles are placed in a circle near the outer boundary of the plerom region, and in the first stages of development they usually alternate with each other. Narrow strips of unchanged plerom parenchyma extending between the fibro-vascular bundles form the *primary medullary rays*. The unmodified parenchyma in the center of the plerom is the pith. The arrangement of the various primary root structures is diagrammatically represented in Plate 30.

**Secondary Root Tissues.**—In certain orders of plants the primary tissues persist with but minor changes throughout life. In the higher orders many changes occur in these primary tissues, resulting in the formation of secondary or permanent tissues, such as those of the bark, and an extension of the

primary plerom elements. The primary root epidermis is replaced by bark structures which originate in the periblem zone. Certain of the primary cortical cells become meristematic and constitute the bark cambium or *phellogen*. The phellogen cells rapidly subdivide and the new tissue formed on their outer side forms the *periderm* or *bark*, while the tissues produced on their inner surface form the *phellogen* or true *bark*. The phellogen retains its meristematic power throughout the life of the individual and can thus provide tissues to keep pace with internal growth. The primary fibro-vascular bundles consists of either xylem or phloem, and, in the change to secondary structure, a meristematic tissue termed *cambium* is developed in connection with these. The cambium occurs on the outer face of each xylem bundle and on the inner face of each phloem bundle. The cambium arc on each xylem bundle produces xylem on its inner face and phloem elements on its outer side. Similarly the cambium arc on each phloem bundle produces xylem on the inner side and phloem upon the outer. Each fibro-vascular bundle now consists of xylem and phloem elements separated from each other by a strip of cambium. The bundles of secondary structure which have been completed by the cambium are termed *complete fibro-vascular bundles* in contradistinction to the *incomplete fibro-vascular bundles* of primary structure. Growth through activity of the cambium is continuous, and finally the parenchymatic tissues of the plerom are almost entirely replaced by xylem. Formation of new fibro-vascular bundles takes place in the broad primary medullary rays, resulting in multiplication of these structures which

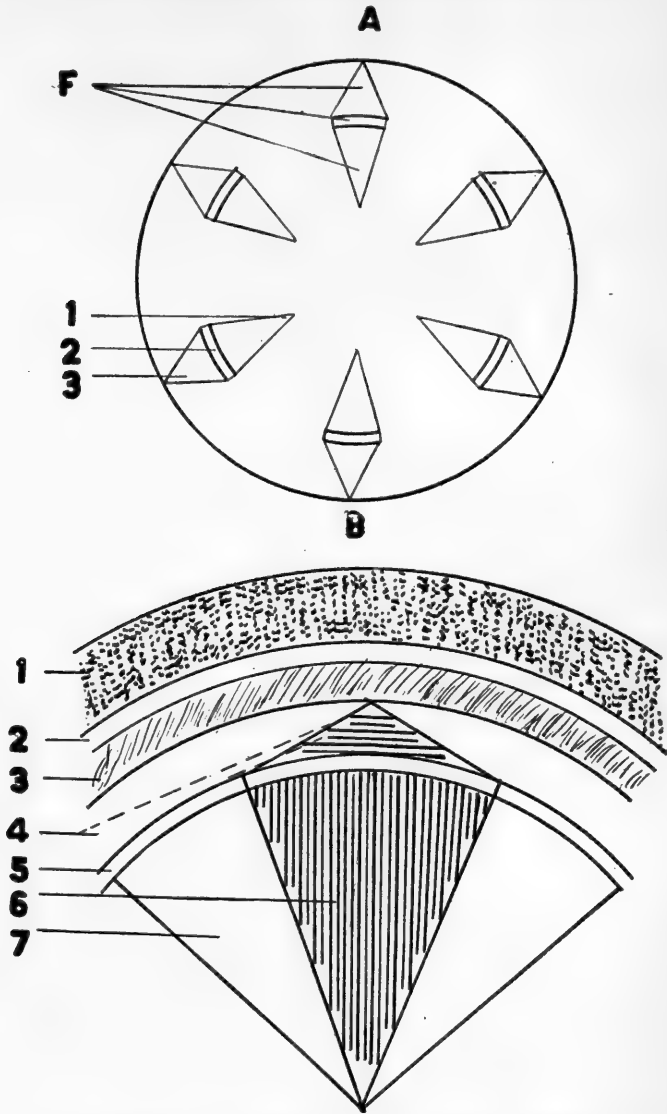

PLATE 31.—A. Completion of Fibrovascular Bundles.

F. Completed fibrovascular bundle. 1. Xylem elements. 2. Cambium. 3. Phloem elements.

B. Arrangement of Secondary Tissues in Roots and Stems.

1. Periderm (bark). 2. Phellogen. 3. Pheloderm (bark). 4. Phloem elements. 5. Cambium. 6. Xylem elements. 7. Medullary rays.

are derived from the original plerom parenchyma. The arrangement of the various secondary root structures is diagrammatically represented in Plate 31.

**Primary Stem Tissues.**—In sections of young stems the dermatogen, periblem and plerom zones are apparent. The dermatogen zone in the stem gives rise to an epidermis consisting either of one layer or of several layers which may show slight variations in structure. Tissues corresponding to those of the root cap and root hairs are not developed, although the stem epidermis may be clothed with various types of hairs. The primary stem epidermis may possess stomata or breathing pores, structures which are never present in the primary epidermal layer of roots. The periblem zone in stems gives rise to hypodermal and endodermal tissues similar to those of the root. The hypodermal cells may contain chlorophyll or green coloring material, which is never present in the corresponding tissue of roots. In most instances, the endodermal cells of primary stems are not as well developed as those of roots. The plerom zone of primary stems is quite different from that of primary roots, as regards arrangement and development of tissues. The fibro-vascular bundles developed in the plerom region of the primary stem are complete bundles, showing phloem, xylem and cambium elements even in the earlier stages of growth (Plate 31). Therefore the primary fibro-vascular bundles of the stem show structures found only in the secondary bundles of the root.

**Secondary Stem Tissues.**—In annual plants the primary stem structures heretofore described persist throughout the short life of the individual; but in

perennials provision must be made for a more durable covering tissue and the extension of the plerom structures. The primary epidermis is replaced by periderm tissues produced by a phellogen developed in the primary cortex. The periderm of stems may differ from that of roots in that it is often cast off or ruptured because of expansion of the inner tissues through growth. *Primary periderm* thus destroyed is replaced by a *secondary periderm* arising directly from the original phellogen or secondary phellogen layers. The hypodermal and endodermal layers disappear with the formation of phellogen within the primary cortex. The primary fibro-vascular bundles increase in size through the addition of xylem and phloem elements by the cambium. The short arcs of cambium are extended laterally so as to form a complete cambium ring or circle. New fibro-vascular bundles are formed in the broad medullary rays which extend between the original bundles. Although new woody elements are continuously added to the original xylem bundles, the growth of wood never entirely replaces the original plerom tissue in the center of the stem. This unchanged plerom parenchyma in the center of stems is termed the *pith*. In roots, the woody tissues entirely replace the plerom parenchyma; therefore presence of a pith region is characteristic of stem structure.

Although the primary tissues serve well enough in the earlier stages of growth, full development necessitates the production of secondary or permanent tissues, and these may be roughly divided into two groups, *parenchyma* and *prosenchyma*. Representative parenchyma cells are found in the undifferentiated

cellular structures of the three zones in the embryo. They are characterized by thin walls and the possession of protoplasmic contents. Typical prosenchyma cells are formed in the plerom region of the embryo. They differ from parenchyma in the possession of thick walls, and the protoplasmic contents are inconspicuous or lacking. These distinctions are not absolute, and the form or shape of the cell may be used as a basis for further classification in doubtful instances. Prosenchymatic elements are usually in the form of long fiber cells with sharp-pointed ends, whereas parenchymatic cells are usually spherical or isodiametric in shape and do not possess pointed ends.

## SUMMARY OF ROOT AND STEM TISSUES

## ROOT

Fundamental  
Tissues.

## Primary Tissues.

## Secondary Tissues.

Dermatogen . . . . .	{ Root cap Root hairs Primary epidermis	All are placed by structures derived from phellogen
Periblem . . . . .	{ Hypodermis Primary cortex Endodermis	
Plerom . . . . .	{ Fibro-vascular bundles (incomplete) Medullary rays Pith parenchyma	

Phellogen { Bork (Periderm)  
Bark (Phellogen)Fibro-vascular bundles (complete)  
Secondary medullary rays  
Replaced by woody tissues

## STEM

## Dermatogen

## Primary epidermis

Replaced by structures arising from phellogen

## Periblem . . . . .

{  
Hypodermis  
Primary cortex  
Endodermis
Phellogen { Bork (Periderm)  
Bark (Phellogen)Fibro-vascular bundles (complete)  
Medullary rays  
Pith parenchymaSecondary fibro-vascular bundles (complete)  
Secondary medullary rays  
Permanent pith



## CHAPTER VII

### THE COVERING TISSUES

COVERING, or protective tissues, are found on all exposed surfaces of the plant. The general function of these tissues is the protection of the vital parts of the plant from injury due to climatic variation or other agents beyond the control of the plant. In northern or even temperate latitudes the plant is subjected to great and fairly rapid fluctuations in temperature, which, if not guarded against, would cause injury to the more delicate plant organs. The covering tissues act as insulators and prevent temperature variations from injuring the plant. In certain instances the plant possesses the faculty of adjusting itself to long-continued periods of high or low temperature; but this adjustment entails a modification of the covering tissues. Plants in tropical regions require protection against the excessive heat of the sun during the dry season and an undue access of water during the rainy period. Both of these adverse conditions are met by modifications in the structure of the covering tissues. The covering tissues of certain floral organs secrete substances which influence pollination. By reason of differences in location, formation, structure and chemical composition, the covering tissues of the plant are subdivided into ; (a) epidermal tissues, including plant hairs, and (b) periderm.

**EPIDERMAL TISSUES**

Epidermal tissues occur on the exposed surfaces of all plant organs and parts other than those of woody structure. Thus leaves, green stems, fruits, seeds and floral parts possess this covering tissue classed as epidermis. The epidermal tissues are derived from the outermost layer of the dermatogen region, and the cell walls are more or less thickened by deposition of cutin, in or around the original cellulose wall. Cutinized cell walls are practically waterproof. Silicates and other inorganic materials are often present in the epidermal tissues of grasses, and probably aid in the support of those plants in which poor development of fibrous supporting tissues is noteworthy. Cutinized tissues frequently have the power of secreting or producing waxes and resins. The gloss on the surfaces of certain leaves is due to the presence of a waxy material which serves as an additional protection against access of water through the epidermis. Resins and sticky substances, occasionally present on the surfaces of leaves and stems, serve the purpose of preventing insect attacks and keeping ants or other crawling insects from gaining access to the flowers. Many of the resins are strong antiseptics and will prevent infection of plant tissues.

**Membranous Epidermal Tissues.**—The epidermal tissue covering leaves, green stems, floral organs and several classes of fruits is in the form of a thin layer of cells. The epidermal membrane of leaves and green stems is colorless and transparent, while that covering fruits and floral parts is usually colored by deposition of various cell contents and is therefore

less transparent. The epidermal membrane (Plate 32) is seldom more than one layer of cells in thickness; and the individual cells are set so closely together that air and water cannot gain access to the inner tissues except through specialized organs called *stomata*, (singular, *stoma*). Stomata are distributed among the epidermal cells, especially those of the lower leaf-surface. Each stoma consists of two semicircular cells surrounding an oval opening or breathing pore. Stomata are of importance in the respiratory processes of the plant. Certain leaves, on sectional view, show several layers of cells apparently similar in structure to the epidermal cells to which they are attached. These layers are termed *subepidermal* cells and occur frequently in leaves of tropical plants, where they serve as a protection against the excessive heat to which such plants are exposed. The individual epidermal cells, as seen on surface view (Plate 33), are polygonal in shape, or else show a very irregular outline, because of their wavy walls. Sectional views show that the upper or exposed surface of the cell is thicker-walled than the surfaces in contact with other cells. The cell walls frequently show markings which are of use in identification. *Striations* are markings or lines parallel with the wall of the cell as seen on surface view. These markings may possibly be due to the deposition of cutin or other protective substances in successive layers. The thickening of the exposed wall may be partially extended into the side walls of epidermal cells, thus affording greater protection. *Beaded cell walls* are side walls which have become thickened at irregular intervals around their circumference or margin. Roughening

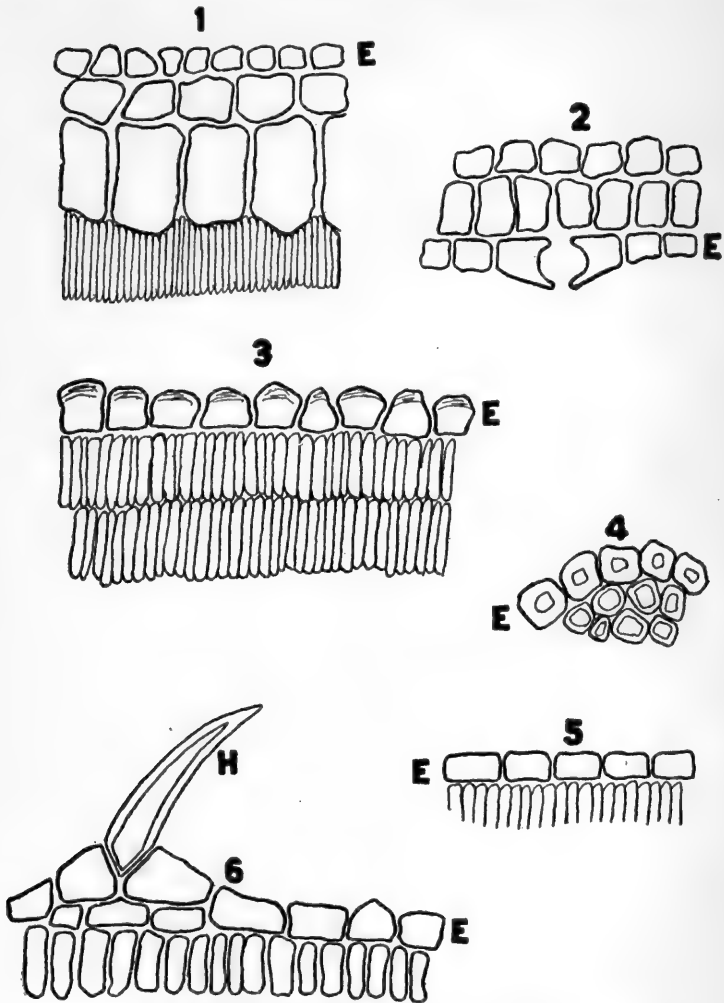

PLATE 32.—Sectional Views of Leaf Epidermis.

1. Upper epidermis, Ficus leaf. 2. Lower epidermis, Ficus leaf. 3. Upper epidermis, Eucalyptus leaf. 4. Epidermis of Pine leaf. 5. Upper epidermis, Orange leaf. 6. Upper epidermis, Geranium (Pelargonium), leaf. *E* = epidermis, *H* = hair.

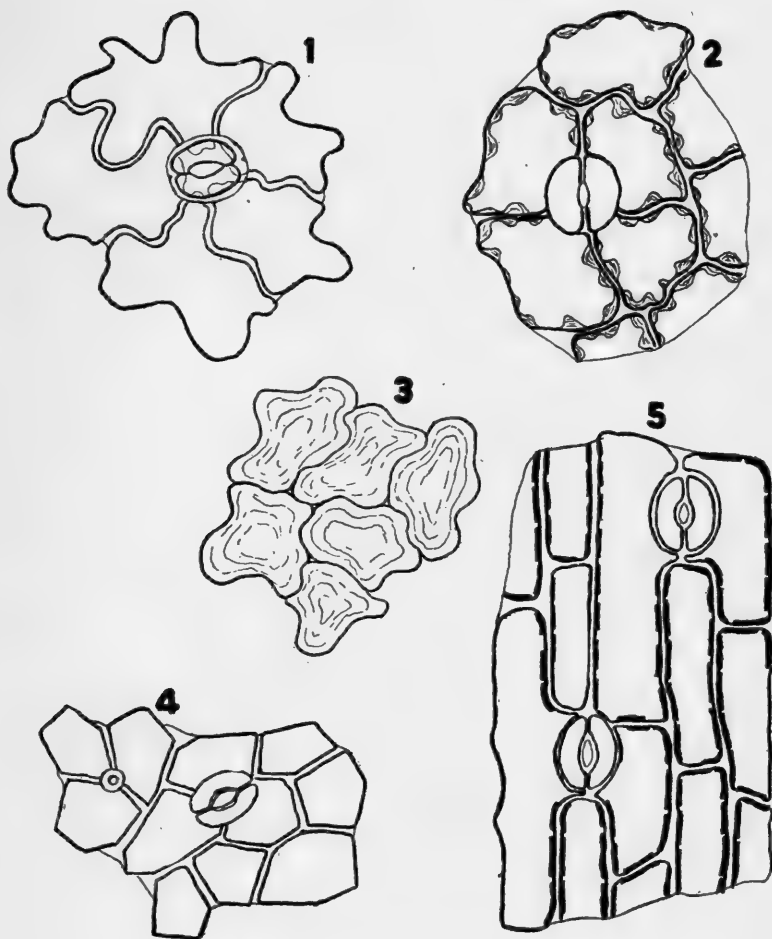

PLATE 33.—Surface Views of Leaf Epidermis.

1. *Hepatica* leaf (wavy walls). 2. *Chimaphilla* leaf (beaded walls). 3. *Henbane* leaf (wavy and striated walls). 4. *Senna* leaf (angled cells). 5. *Convallaria* leaf (beaded walls).

on the exposed surfaces of epidermal cells may be due to striations, beading or presence of plant hairs.

**Thickened Epidermal Tissues.**—The epidermal tissue covering seeds and certain classes of fruits is in the form of one or more layers of thick-walled cells, constituting the testa or outer coat of seeds and the exocarp of fruits (Plate 34). Stomata are never present in seed epidermis but are occasionally present in fruit epidermis. Protection of the embryo and of the nourishing materials in the seed is the chief function of the testa. The seed epidermis is necessarily thicker and stronger than the membranous epidermal tissues, because the seed must retain its vitality for long periods even under the most adverse conditions. The epidermal cells of seeds and fruits usually contain pigment materials and therefore appear colored. The subepidermal layers may secrete mucilaginous substances through modifications of the cell walls. The swelling which occurs when the mucilaginous substance comes into contact with water tends to rupture the tough epidermis, thus making possible the egress of the embryo. Waxy secretions are occasionally present on the surface of the seed.

#### PLANT HAIRS

Plant hairs or *trichomes* are prolongations or outgrowths of the epidermal cells. In certain instances the trichome is merely an expansion of the exposed surface of the epidermal cell, while in others, cell division has occurred and the hair consists of several well-defined cells. Trichomes may occur on the epidermal surfaces of leaves, green stems, floral organs,

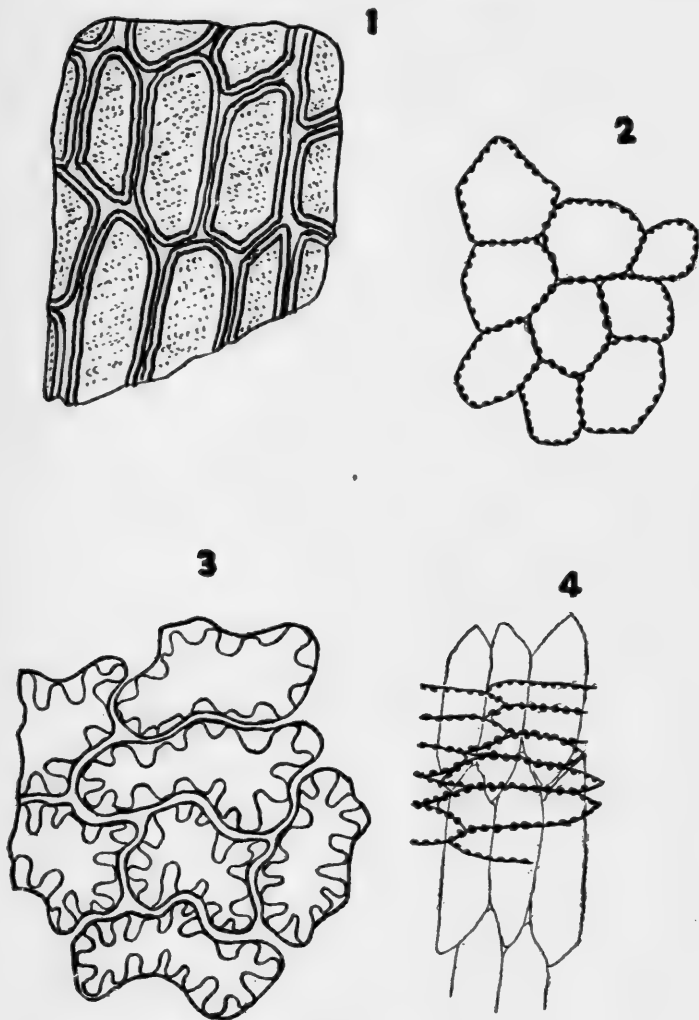

PLATE 34.—Surface Views of Seed Epidermis.

1. Lobelia seed (thick walled, angled cells). 2. Mustard seed (finely beaded walls). 3. Capsicum seed (wavy and thick beaded walls). 4. Wheat seed (angled and finely beaded walls).

fruits and occasionally seeds. The cell walls are cutinized and, in certain hairs, secretory organs or glands are present. The absence or presence of glands is the primary basis of classification into *non-glandular* and *glandular* hairs. The cells of a trichome may be living or dead. Living hairs are characterized by possession of protoplasmic contents and inclusions within the cell. In dead hairs the cell cavities are filled with air. Although cutinized cell walls are the usual rule, there are instances where the walls of hairs consist partly of lignified tissue; trichomes of this sort are apt to be thicker and more like bristles.

**Non-glandular Trichomes.**—The functions of non-glandular hairs include protection against temperature changes, excessive evaporation of water and attacks of insects. The simplest type of non-glandular hair consists of a slight projection of the exposed epidermal surface. This form of hair is termed a *papilla* (plural, *papillæ*) and appears as a wart or blister upon the epidermal surface (Plates 35–36). On surface view papillæ appear as thick-walled circles, one within each epidermal cell. On sectional view they appear as a series of elevations on strips of epidermal tissue.

**Classification.**—Non-glandular hairs may be classified according to the number of cells in the hair, the number of hairs in the group, the presence or absence of branches and the arrangement of the cells in each hair. This classification may be tabulated as follows:

- (a) Number of cells in the hair;  
unicellular—multicellular.
- (b) Number of hairs in the group;  
simple—compound.



- (c) Branching;  
    non-branched—branched.
- (d) Arrangement of cells;  
    uniseriate—multiseriate.

*Unicellular hairs* consist of but one cell, whereas *multicellular hairs* consist of many cells. If but one hair originates from an epidermal cell it is termed a *simple hair*, as distinguished from a *compound hair* in which several trichomes have their origin in one epidermal cell. The terms *branched* and *non-branched* are self-explanatory; but the distinction between compound and branched trichomes must be kept clearly in mind. Branched forms differ from compound forms in that the former project from the epidermal cell as a single hair, and the branching occurs at some point above the origin. *Uniseriate trichomes* are multicellular forms in which the several cells composing the hair are arranged in a single row or series. *Multiseriate trichomes* are likewise multicellular, but the cells composing the hair are arranged in several parallel rows or series. In describing plant hairs the four points enumerated above must be taken into consideration. The hairs of cannabis and senna are unicellular, simple and non-branched. The hairs of digitalis and matico are multicellular, simple, non-branched and uniseriate. The hairs of althæa leaves are unicellular, compound and non-branched. Among the several kinds of hairs present in arnica flowers, we find multicellular, simple, non-branched and multiseriate types. Mullein leaf possesses simple, multicellular, branched, uniseriate trichomes. The various types of trichomes are illustrated in Plates 35, 36 and 37.

The cells of non-glandular trichomes often show

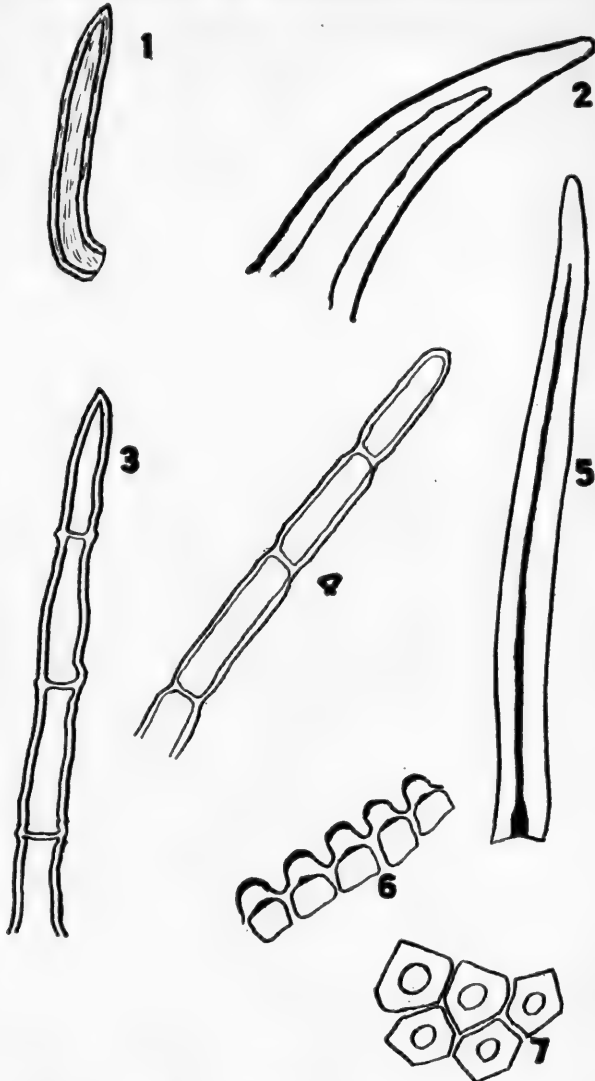

PLATE 35.—Nonglandular Plant Hairs.

1. Senna leaf. (Simple, unicellular, nonbranched). 2. Cannabis herb. (Simple, unicellular, nonbranched). 3. Matico leaf. (Simple, multicellular, nonbranched). 4. Digitalis leaf. (Simple, multicellular, nonbranched). 5. Tea leaf. (Simple, unicellular, nonbranched). 6. Coca leaf, Papillæ, sectional view. 7. Coca leaf. Papillæ, surface view.

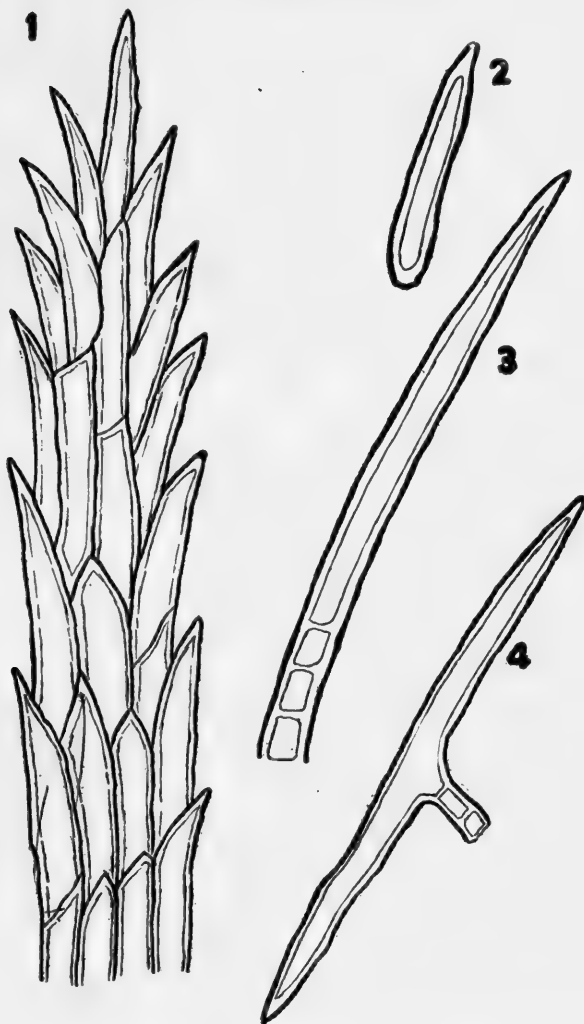

PLATE 36.—Nonglandular Plant Hairs.

1. Arnica flowers. (Simple, multicellular, multiseriate.) 2. Coca leaf stem. (Simple, unicellular.) 3. Anthemis flowers. (Simple, multicellular, uniseriate.) 4. Absinthium leaves. (Simple, multicellular.)

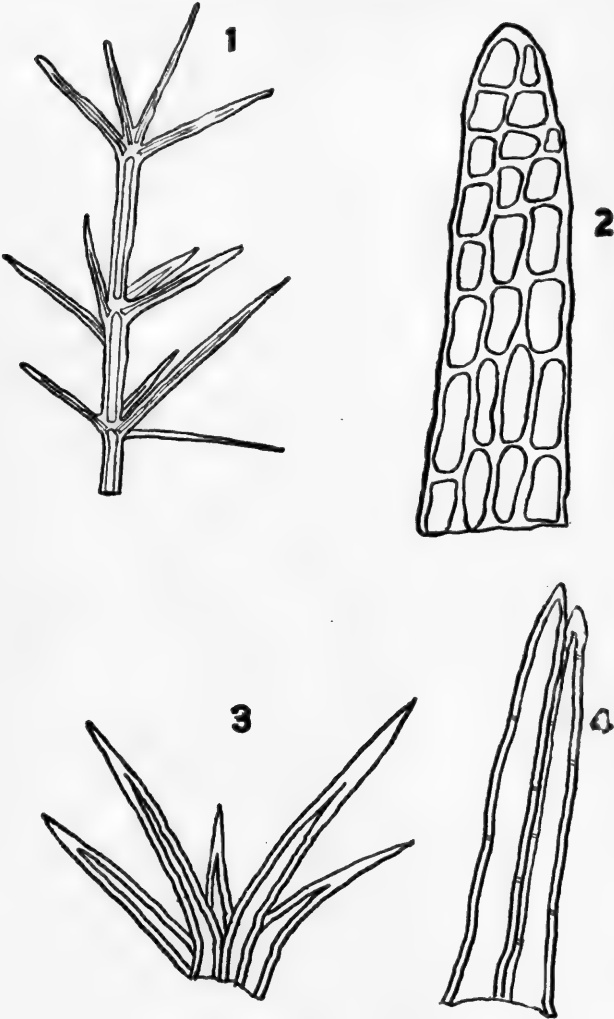

PLATE 37.—Nonglandular Plant Hairs.

1. Mullein leaves. (Simple, multicellular, branched.) 2. Geranium (*Pelargonium*) stem. (Multicellular, multiseriate.) 3. *Althaea* leaves. (Compound, unicellular.) 4. *Arnica* flowers. (Bicellular, biseriate.)

markings or other peculiarities which may be of importance in identification work. Striations extending parallel with the length of the hair are often present. The *papillose surface* of peppermint and stramonium hairs is caused by small projections upon the surface of the hair. In absinthium the large *terminal cell* of the hair stands at right angles to the *basal cells*, a characteristic observed in but a small number of plants. The hair of anthemis shows a terminal cell many times longer than the basal cells. One type of hair occurring in thyme leaves is two-celled with the terminal cell bent in a distinctly different direction from that of the basal cell. *Biseriate* or twin hairs are found in arnica flowers. Hairs frequently show projections or barbs along the edge of the cell. In multicellular hairs these projections may be formed by individual cells, but in unicellular hairs they are *emergences* or projections from the cell wall. Barbed hairs play an important part in the protection and distribution of seeds. The hairs of stinging nettle (*Urtica dioica*) contain secretions which, if injected under the skin, cause severe irritation. In other instances (particularly cowage, *Mucuna pruriens*), plant hairs are provided with recurved barbs by means of which they become firmly embedded in the skin and thus act as irritants.

**Glandular Trichomes.**—A glandular trichome consists essentially of a gland or secreting organ which is in direct contact with the epidermal surface, or is raised above this surface by means of a stem or stalk. *Sessile glandular hairs* are directly attached to the epidermis. In *stalked glandular hairs* the gland is raised above the epidermal surface and attached to

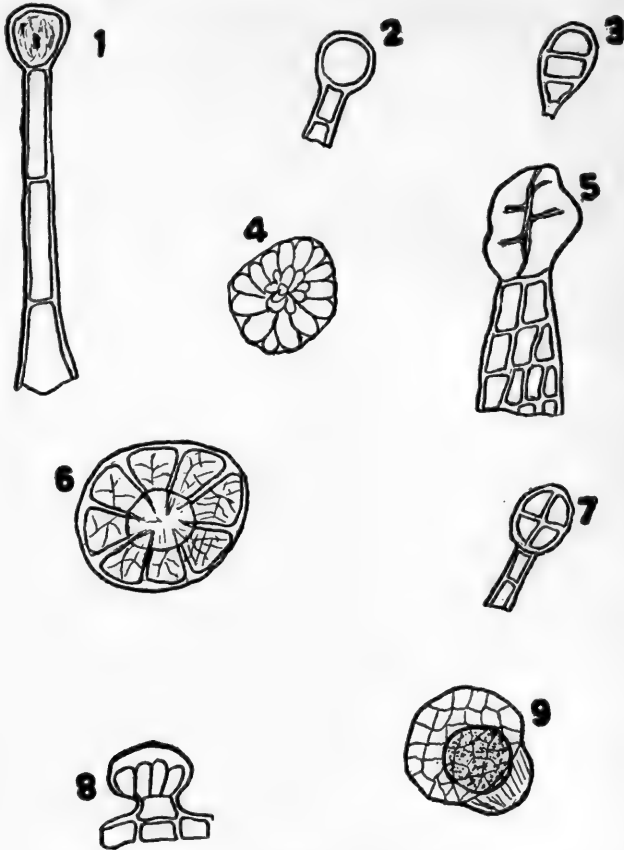

PLATE 38.—Glandular Plant Hairs.

1. Geranium (*Pelargonium*) stem. (Multicellular stalk, unicellular gland.)  
 2. Sage leaves. (Multicellular stalk, unicellular gland.) 3. Sumac fruit. (Sessile, multicellular gland.) 4. Kamala fruit. (Sessile, multicellular gland in surface view.) 5. Cannabis herb. (Multiseriate stalk, multicellular gland.) 6. Peppermint leaves. (Sessile, multicellular gland in surface view.) 7. Stramonium leaves. (Multicellular stalk, multicellular gland.) 8. Lavender flowers. (Sessile, multicellular gland in sectional view.) 9. Lupulin. (Sessile, multicellular gland in sectional view.)

it by the stalk. The gland or secreting organ may be unicellular or multicellular. The terms used in the description of non-glandular hairs are used in

reference to the stalk of a glandular hair. The glandular hairs of cannabis possess a multicellular gland with multiseriate stalk. The glandular hairs of pelargonium (commonly called geranium) possess a unicellular gland upon a multicellular, uniseriate stalk. Various types of glandular hairs are illustrated in Plate 38. The formation of glandular hairs and the products secreted will be considered under the head of Secreting Tissues.

### PERIDERM

Periderm occurs on the exposed surfaces of woody roots and stems. The primary epidermal tissues originating from the dermatogen zone do not afford sufficient protection to mature parts of the plant, nor can they keep pace with the growth of the inner tissues. The necessity for a stronger covering arises, and is met by the production of cork by a meristematic tissue located in the primary cortex or immediately beneath the primary epidermis. This meristematic tissue is termed *phellogen* or *bark cambium*, and produces cork tissue on its outer surface and phelloderm upon its inner face. With the exception of a region near the phellogen, the cork layers are composed of dead cells. The phellogen tissues are of importance in bark structure and will be considered under that heading in a subsequent chapter. The walls of cork cells are composed largely of suberin and the cell contents usually include tannins. The individual cells are always dark-colored, and are so fitted together that very little intercellular space is apparent. Upon surface view the cells are usually polygonal in outline, and occur in thick masses in which the outlines of the individual

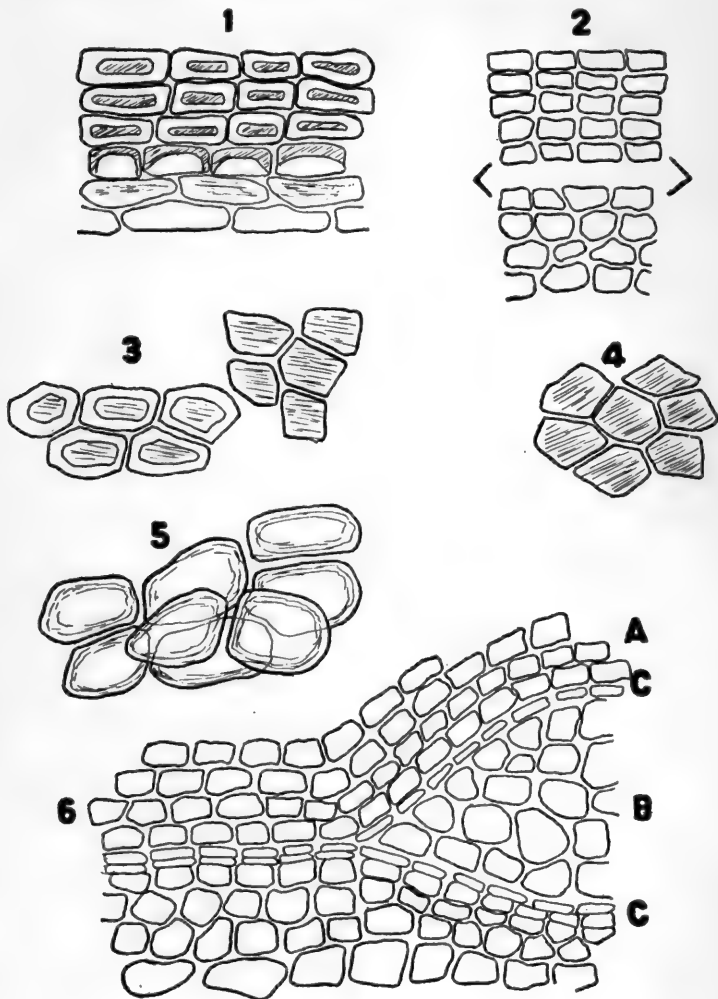

PLATE 39.—Cork Tissue.

1. Saigon Cinnamon. (Sectional view.) 2. Cascara Sagrada. (Sectional view.) 3. Saigon Cinnamon. (Surface view.) 4. Cascara Sagrada. (Surface view.) 5. Viburnum Opulus. (Surface view.) 6. Euonymus, stem bark. (Sectional view.) Formation of secondary periderm. A. Primary periderm. C. Layers of phellogen. B. Parenchyma included in secondary periderm.



cells are obscure. Upon sectional view the cells appear rectangular or oblong in form and are usually arranged in regular rows (Plate 39). Irregular thickening of the walls of cork cells may be noted in some instances, the walls toward exposed surfaces being usually so thickened. In fully mature plants, especially old trees, the periderm consists of cork together with parenchyma, fibrous elements and, in some instances, stone cells (Plate 39). These additional structures result from the formation of corky tissues beneath fissures or cracks in the original periderm. The corky layers are produced by a secondary phellogen region established well within the fissure. Increasing amounts of cork are produced and the tissues external to this new periderm are thus forced outward, finally becoming part of the outer bark or bork.

The functions of cork cells are to afford protection against mechanical injury, insect attacks and access of water to the inner tissues, and to prevent loss of water through excessive evaporation.

## CHAPTER VIII

### SUPPORTING TISSUES

THE necessity for a framework or skeleton arises fairly early in the life of the plant, and the supporting or mechanical tissues which serve this purpose are developed from groups of cells in the plerom zone. The process of formation involves the deposition of lignin around the original cellulose walls of certain plerom cells. Lignification of the cell walls may be accompanied by a great increase in the length of the plerom cells so changed. The mechanical tissues not only serve as a framework, but are also protective tissues, in that they enable the plant to resist the effects of wind, the attacks of animals and other external forces which might injure or uproot it. In large trees supporting cells form the bulk of the tissues present, because it is necessary that a weight of perhaps several hundred pounds be sustained in the position most favorable for growth.

The supporting elements of the plant include fibrous tissues, schlerenchymatic or stone cell tissue and collenchymatic tissue. While fibrous tissues and collenchyma may be formed early in plant life, stone cell tissue represents a later development. The endodermal cells which form the inner boundary of the periblem region possess thickened walls and may function as a supporting tissue in the early stages of growth.

**Fibrous Tissues.**—Fibrous tissues are found in practically all parts of the plant excepting the seed, although the relative amount present in the different organs varies considerably. The greatest amount is found in woody stems and the least in floral organs. Each fiber is an elongated or spindle-shaped cell and is always several times longer than it is broad. The ends of these fiber cells may be sharp-pointed or blunt, with oblique end walls. Occasionally the walls retain part of the original cellulose around which the lignin has been deposited, and this combination is termed *lignocellulose*. The protoplasmic contents are usually lacking in fiber cells, and in well-matured plants the fibers are to all intents dead tissue. The fiber-cell walls are usually more or less thickened through the lignification process and in some instances appear *striated*, or show fine markings extending parallel to the length of the fiber. The cell cavity is termed the *lumen* of the fiber and may be of large or small size, depending upon the thickness of the wall. Certain fiber cells show pores or small openings in the wall of the cell through which materials may pass from the intercellular space into the lumen. In comparatively few instances the fibers are branched and, instead of appearing as long tapering cells, are irregular in form. Non-protoplasmic contents or cell inclusions occasionally occur in the lumen of a fiber, and may include calcium oxalate crystals, starch and coloring materials. Fibers containing calcium oxalate crystals within the lumen or apparently upon the surface of the fiber are termed *crystal-bearing*. In descriptions and illustrations of fiber cells the longitudinal or side view is usually considered, as on sectional view one merely obtains an

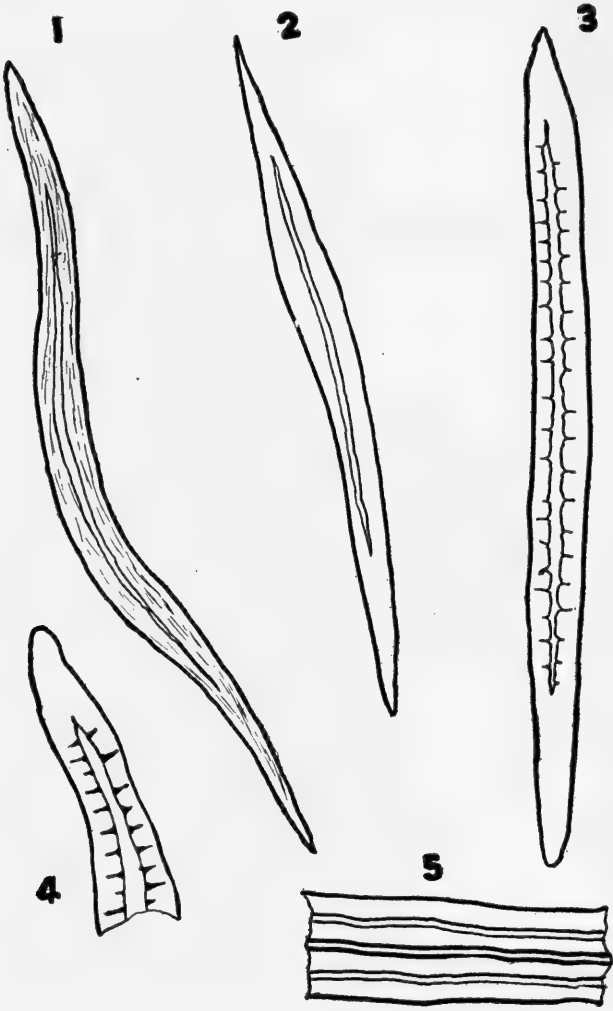

PLATE 40.—Fibers.

1. Baptisia root. (Nonporous, striated.) 2. Ceylon Cinnamon bark. (Nonporous, nonstriated.) 3. Hydrangea root. (Porous, nonstriated.) 4. Echinacea root. (Porous, nonstriated.) 5. Senna leaf. (Nonporous, nonstriated.)

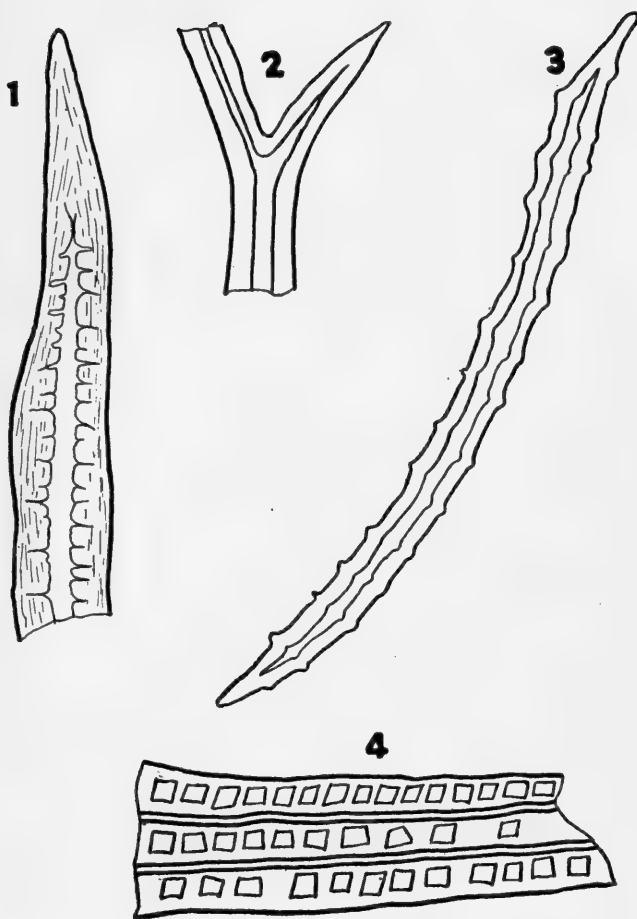

PLATE 41.—Fibers.

1. Cinchona bark. (Porous, striated.) 2. Tonga root. (Branched, nonporous, nonstriated.) 3. Nettle root. (Porous, nonstriated.) 4. Cascara Sagrada bark. (Crystal-bearing.)

idea of the diameter of the fiber and the relative size of the lumen. In sectional view, fibers are rarely circular in outline, as one or more sides are flattened because of the pressure of surrounding tissues. Various types of fibers are illustrated in Plates 40 and 41.

**Classification.**—In describing fibers, the following points should be noted:

1. Presence or absence of pores;  
porous and non-porous types.
2. Presence or absence of striations;  
striated and non-striated types.
3. Branching;  
branched and non-branched types.
4. Presence or absence of crystals;  
crystal-bearing and non-crystal-bearing types.

**Wood and Bast Fibers.**—In tracing the origin of plant tissues we learned that two types of conducting tissues were developed in the pterom region, and that each of these was associated with a fibrous or supporting tissue. One of these supporting tissues was termed *xylem fiber* or *wood fiber* and the other *phloem fiber* or *bast fiber*. There are slight histological differences between wood fibers and bast fibers. Wood fibers are usually thicker-walled and shorter than bast fibers. Pores, when present in wood fibers, are usually oblique and few in number, whereas in bast fibers the pores are horizontal to the long axis of the cell and rather numerous. As wood fibers are more brittle than bast fibers they are more apt to be broken in grinding, and while complete bast fiber cells may easily be found in powdered materials it is seldom that wood fiber cells remain intact.

**Schlerenchymatic Tissue.**—Schlerenchymatic tis-

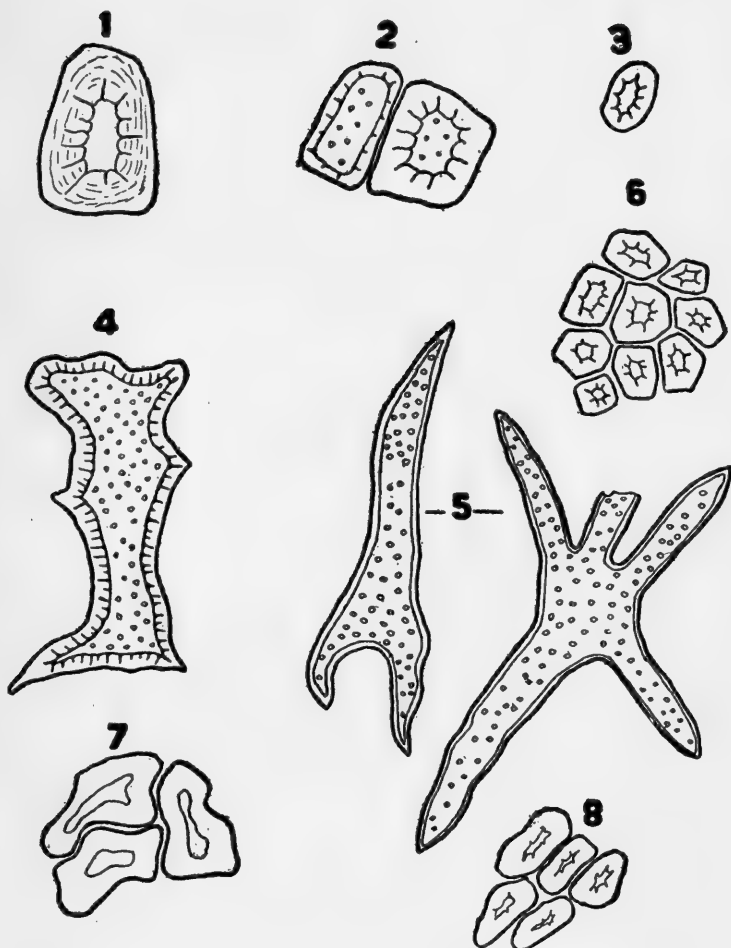

PLATE 42.—Stone Cells.

1. *Chionanthus* bark. (Porous, striated.) 2. Ceylon Cinnamon bark. (Porous, nonstriated.) 3. *Xanthoxylum* bark. (Porous, nonstriated.) 4. Tea leaf. (Branched, porous.) 5. Pond Lily rhizome. (Branched, porous.) 6. Pepper fruit. (Porous, nonstriated.) 7. *Prunus* bark. (Nonporous, nonstriated.) 8. *Cascara* bark. (Porous, nonstriated.)

sues or *stone cells* may be found in all parts of the plant with the exception of the floral organs. The seed coat often contains large amounts of this tissue as it forms a hard protecting envelope for the embryo and other parts of the seed. Stone cells are particularly apt to be present in the stems of leaves, flowers and fruits as well as in barks. Stone cell walls are composed of ligno-cellulose. The deposition of lignin with the consequent formation of stone cells takes place at a later period than the transformation of pterom cells into fibrous tissue. The term *schlerenchyma* is sometimes indiscriminately applied to all hard tissues, and when so used includes wood fibers, bast fibers and stone cells. Stone cells appear as rectangular, polygonal and irregular thick-walled cells, the length seldom being more than three times the diameter. The thickness of the wall and, consequently, the size of the cell cavity vary considerably in the different types. Striations and pores may be apparent and the cavity may contain inclusions.

In describing stone cells the following points should be noted:

1. Presence or absence of pores;  
porous and non-porous types.
2. Presence or absence of striations;  
striated and non-striated types.
3. Branching;  
branched and non-branched types.

Stone cells, with the possible exception of the branched types, remain intact during grinding and owing to their close contact, usually occur as masses in powdered materials. Various types of stone cells are illustrated in Plate 42.



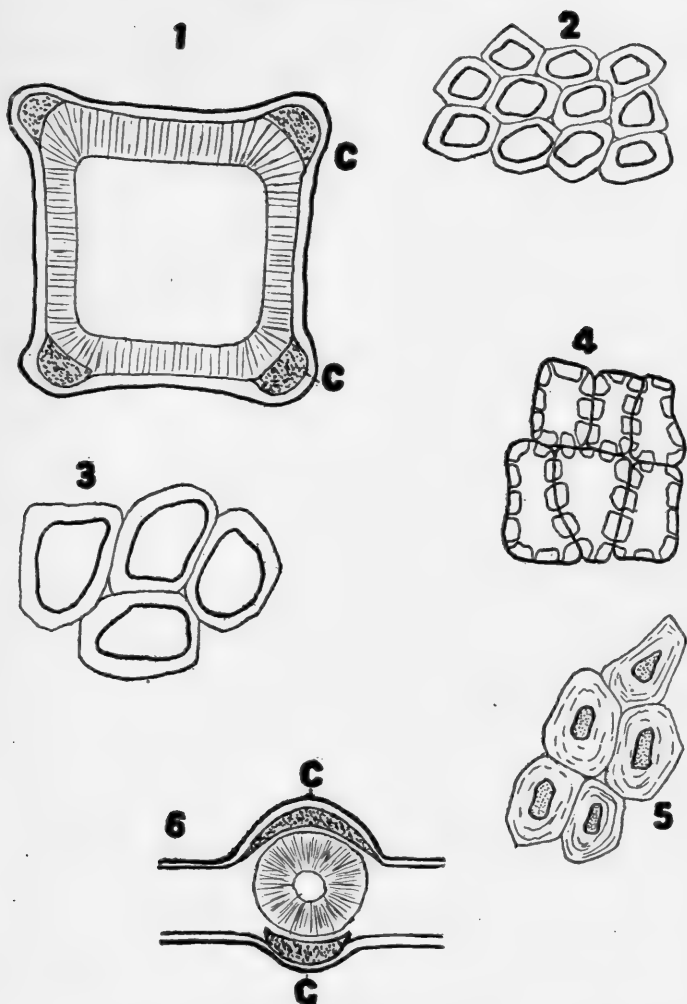

PLATE 43.—Collenchymatic Tissue.

1. Peppermint stem. Arrangement of collenchymatic (C), tissues at angles of the stem. 2. Peppermint stem. 3. Sabal seed. 4. Colchicum seed. (Porous type.) 5. Nux Vomica seed. (Striated type.) 6. Arrangement of collenchymatic tissues around the midvein of a leaf. C = collenchyma.

**Collenchymatic Tissues.**—Collenchymatic tissue may be found in herbaceous or green stems, fruits, seeds and leaves. This element not only serves purposes of support, but is also an assimilation and storage tissue. In the green stems of annual plants little time is available for the formation of woody tissues in large amounts, nor are these necessary when one considers the short life of such plants. Collenchymatic tissues are more quickly produced and can be so arranged in the herbaceous stem that they serve the purpose of support quite as well as woody tissue. The walls of collenchyma cells are composed of cellulose, but the original cell wall is reinforced by deposition of additional layers of cellulose, until a thick, strong wall is built up. Collenchyma appears in the form of polygonal cells with their walls especially thickened at the angles (Plate 43). The wall is white and of pearly luster. Striations and pores may be present, and the latter may communicate with corresponding pores of an adjacent cell. There is but little intercellular space between collenchyma cells; therefore the cell cavities stand out clearly in a white background of wall substance. One must not mistake these cell cavities for cells, and careful search is often necessary to establish the boundaries of the cell walls surrounding each cavity. In herbaceous stems, particularly the square stems of the Labiatae or Mint family, the collenchymatic tissue is placed at the four angles of the stem, with perhaps a secondary group between those at each angle. This arrangement places the collenchyma at the points of greatest stress. Collenchyma is usually associated with the fibrous tissues in the midrib of the leaf.

## CHAPTER IX

### ABSORPTION TISSUES

THE great majority of plants are dependent for their nutrients upon materials contained in the soil and in the air. The nutritive processes of plants differ from those of animals in that the former manufacture nutrients from compounds of very simple chemical composition, as water, oxygen, carbon dioxide and inorganic salts. Animals are ultimately dependent upon the nutrients built up by plants, because the nutrition processes of animals involve a breaking down of the complex substances manufactured by plants. The plant is provided with special organs for the ready absorption of water from the soil and gases from the air.

#### ABSORPTION OF WATER

As previously noted, the primary root tissues in the dermatogen zone are root cap, root hairs and epidermis. The root cap cells protect the delicate root tissues from injury through contact with sharp soil particles. The cells of the root cap are rather thick-walled and play no part in the absorption of materials from the soil. The epidermal cells of the root are also thick-walled and are more or less impervious to water. The root hairs are directly concerned in the work of absorbing water, which holds in solution the salts occurring in the soil. These hair-like

structures are located just above the root cap and form a narrow zone between this and the parts of the root covered with epidermis (Fig. 44, No. 1). They are found only on the smallest branches of the root and, although the absorbing surface of each hair is very small, in the aggregate they present an absorbing surface as large and widespread as that of the leaves. Root hairs are similar to trichomes in derivation and are therefore outgrowths of the epidermal cells. Each is in the form of a long, slender, finger-like projection from an epidermal cell. Their walls are extremely thin, and it is possible that the acid reaction, which is apparent when root hairs come into contact with moist litmus paper, is due to an acid secretion. An acid secretion in the vicinity of the root hairs would be very desirable because it would convert many insoluble soil constituents into soluble compounds which are dialyzable. The raw materials consisting of water with dissolved salts dialyze through the thin walls of the root hairs. They eventually find their way into tubes or vessels through which they are transported to other parts of the plant to be manufactured into assimilable substances. The walls of root hairs are composed of cellulose and may show slight coloration. In the living plant, root hair cells are always in a region of active growth and therefore protoplasmic cell contents are present.

In certain instances the work of absorbing liquids may be performed by plant organs other than root hairs. Plants of parasitic habit and those growing in desert regions show particular adaptability as regards means of absorbing water. *Parasitic plants*, or those which gain their nutrients by burrowing into the tis-

sues of other plants, are usually lacking in root hairs. Absorption of water in this type of plants may take place through the modified epidermis of the aerial roots which are usually present. For their supplies of water, desert plants must depend largely upon dew and very short periods of rain, as the soil in which they live is almost devoid of moisture. Plants living under these conditions have little need for root hairs and these structures are usually lacking. The leaf and stem epidermis of desert plants is so modified that absorption of water can take place through these parts. As the roots of aquatic plants are surrounded by water there is little necessity for an extensive root hair development in these types. Root hairs are very delicate structures and they are seldom found intact in powdered drugs or foods. Where plants are removed from the earth by force, the rootlets bearing root hairs are usually detached and therefore are not apparent.

#### ABSORPTION OF GASES

Absorption of gases takes place through small openings termed stomata located in the leaf epidermis, and through irregular fissures or lenticels occurring in the periderm of mature plants. The gases entering the plant through stomata or lenticels are distributed to the individual cells by passage through intercellular spaces or by gradual diffusion through thin-walled cells.

**Stomata.**—Stomata occur in the covering membranes of leaves, herbaceous stems and sepals of the flower (Plate 44). They are occasionally found in the epidermal membranes covering the petals and

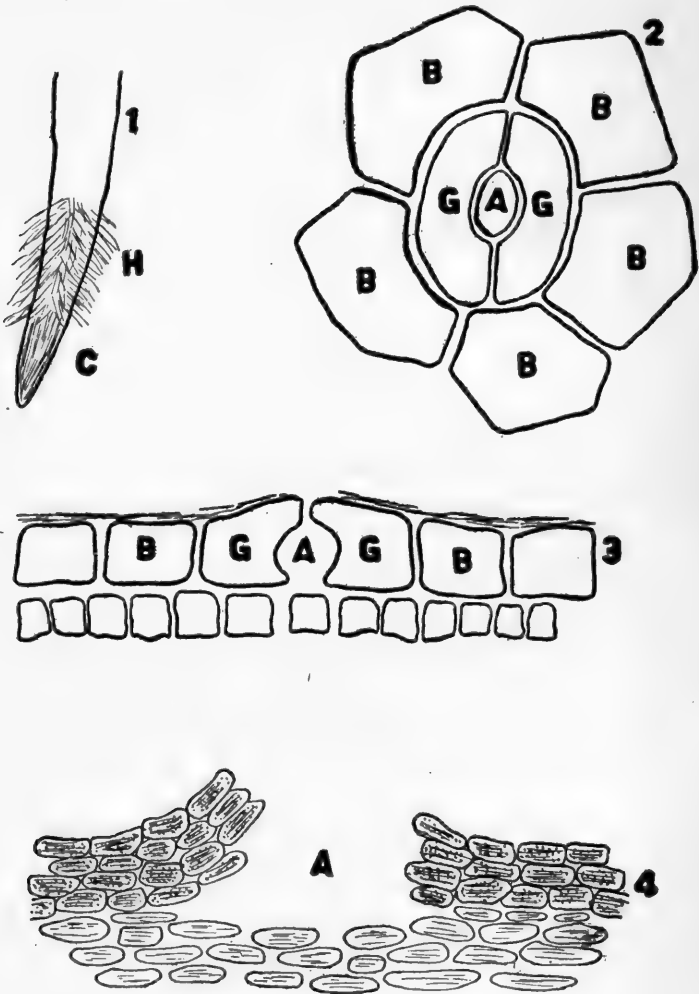

PLATE 44.—Tissues for Absorption.

1. Root hairs (*H*) on rootlet of germinating Fenugreek seed. *C*=root cap. 2. Stomata, surface view. *A*=breathing pore. *G*=guard cells. *B*=bordering, neighboring or surrounding cells. 3. Stomata, sectional view. *A*=breathing pore. *G*=guard cells. *B*=bordering cells. 4. Lenticel (*A*).

ovary of the flower. The lower surface of the leaf shows the greatest number of stomata and the upper leaf surface may be entirely devoid of them. The stoma proper is an oval opening perforating the epidermis, and is surrounded by two semicircular cells termed *guard cells*. The guard cells are in turn surrounded by a number of epidermal cells called *surrounding*, *bordering* or *neighboring* cells. In literature on vegetable histology, the term stoma includes the opening in the epidermis together with the two guard cells. The number and arrangement of the surrounding cells is fairly constant for a given species, and this fact may often be used for purposes of identification. The guard cells are modified epidermal cells and usually contain a small number of chloroplasts as a protoplasmic cell content. The stoma may be above, below or on the same level as the epidermal cells. The size of the breathing pore varies under different conditions and is regulated by contraction and expansion of the guard cells. Variations in the amount of water in these cells are responsible for the changes in size.

**Respiration.**—A supply of air is just as necessary for the continuance of life in plants as it is in animals. The air entering the stomata or lenticels contains oxygen and carbon dioxide. The oxygen is essential to cell life and activity, while the carbon dioxide is used by the plant in the manufacture of nutrients. The respiratory processes include the absorption of oxygen through the stomata or lenticels and the distribution of this element to the cells through intercellular spaces or by gradual diffusion through thin-walled cells. Carbon dioxide is one of the waste

products resulting from the activity of the cell and is excreted through the stomata. In the consideration of assimilation processes (Chapter XI), it will be noted that carbon dioxide is consumed and oxygen produced, the parts played by the two gases being exactly the reverse of those observed in plant respiration.

**Transpiration.**—The mineral salts absorbed by the root hairs are in extremely dilute solution, and, in order to secure appreciable amounts of these inorganics, the plant must absorb an enormous amount of water. Water is a necessary constituent of cell protoplasm but the quantity absorbed is far in excess of the needs of the plant. The excess water must be eliminated, or excreted, by the stomata. Mention of the mechanism by which the size of the breathing pore is regulated has previously been made. This regulation serves to control the rate of transpiration or elimination of excess water. When large amounts of water are present in the guard cells and surrounding tissues, the stoma is wide open so that water vapor may readily pass from the intercellular spaces to the atmosphere. When the amount of water in the guard cells is small, they flatten out and close the stoma, thus preventing evaporation from the inner tissues.

In a few genera, elimination of excess water is accomplished by openings termed *water pores*, which are located around the margin of the leaf, and which communicate directly with the tubular structures found in the veins of these parts. Water pores are similar to stomata in structure, but the pore or opening is not regulated by variations in the size of the surrounding cells and is always open.



**Lenticels.**—Lenticels are respiratory openings in the periderm or corky covering tissues of mature woody plants. These openings expose the tissues immediately beneath the cork and air thus gains access to these cells. On surface view the lenticel appears as an elliptical or oval scar raised above the surrounding tissues. Microscopic examination of sections through a lenticel shows a break or gap in the cork cells through which the inner bark tissues are exposed (Plate 44). The inner bark cells in the vicinity of a lenticel are loosely connected and large intercellular spaces are apparent. Lenticels are not mere chance fissures in the bark, but are formed from the meristematic tissue (phellogen) which produces cork. At points of formation the phellogen produces a group of compact cells, which are gradually forced outward until they rupture the existing cork layer, thus giving rise to a lenticel.

## CHAPTER X

### CONDUCTING TISSUES

THE crude materials in solution absorbed by the root hairs must be transported to the leaves for manufacture into nutrients. The nutrients produced by the leaves must subsequently be distributed to all parts of the plant. In view of these facts the necessity of a system for the conduction or transportation of crude and manufactured materials is clearly apparent. The absorbing tissues are located at the two extremes of the plant, the root hairs at the lower, the leaves at the upper; and communication between these is effected by a system of tubular structures. The conducting tissues are found in all parts of the plant, with the exception of the outer bark, the epidermal membranes and the seed. The outer layers of the bark consist of dead cells; and those cells near the phellogen are nourished by transfusion of nutrients from cell to cell. The epidermal and seed tissues are nourished in the same manner as the cells of the inner bark. The structures concerned in the transportation of materials in the plant include ducts, sieve tubes, medullary rays, latex tubes and perforated parenchyma.

**Ducts.**—Ducts, tracheæ or vessels are continuous tubes extending for considerable distances within the plant body. They are formed by fusion of a vertical

row of adjacent cells and subsequent absorption of the end walls of these cells. The walls of ducts are partially lignified and therefore consist of ligno-cellulose. As the duct is a structure formed from many cells, each of which has lost its identity, protoplasmic contents are absent and the tissue is practically lifeless. Differences in the arrangement of the lignified substance within the vessel offer a convenient basis for classification. Lignification takes place in a systematic manner, each species showing peculiarities which may often be used as a factor in the identification of a given plant. Different organs of a plant will show different types of vessels, although the type is definite for each organ. The types of ducts include pitted, reticulate, scalariform, annular and spiral forms. *Pitted ducts* are characterized by the presence of numerous pores or openings through the ligno-cellulose wall of the vessel. The layer of lignin lines all portions of the vessel but shows numerous perforations or pores. In *reticulate ducts* the lignified tissue is in the form of a network upon the inner face of the vessel wall, and the portions not covered by lignin are irregular in outline. The non-lignified portions of the walls of *scalariform vessels* are in the form of long narrow slits showing fair uniformity both as regards size and arrangement. Scalariform vessels are often angled, and in this respect differ from all other types. *Annular vessels* are rather thin-walled tubes possessing rings or hoops of lignified tissue within the lumen of the tube. In the *spiral vessels* the lignified tissue is arranged in the form of a continuous spiral band or collection of bands extending throughout the length of the vessel. Lignification

in the spiral and annular types is such as to afford the maximum of support with the minimum of material, and these forms are usually present in leaves or other parts of the plant which do not survive more than a season.

**Tracheids** are conducting cells in which the walls between adjacent cells have not been entirely obliterated. Communication between the various cells forming a tracheid is effected by means of pores in the vessel walls. The pits in the tracheid walls are termed bordered pores and each appears as a small elevation in the center of which may be a valve-like flap of tissue.

In general the ducts conduct materials toward the leaves. The materials contained within the duct are simple substances in aqueous solution and are to be transformed by the leaves into nutrients. Various types of ducts are illustrated in Plate 45.

**Sieve Tubes.**—Sieve tubes differ from ducts in that they consist of single cells, each of which is a unit in the transportation of materials. The sieve tubes are formed by perforations in the end walls of each cell of a vertical row. These perforated end walls between adjacent cells may be more or less consolidated so that the pores of each wall coincide with those in the walls of the cells above and below. The perforated and partially consolidated end walls are termed *sieve plates*. In transverse sections of cells containing sieve plates the latter appear as yellowish perforated structures entirely filling the cell (Plate 46, No. 2). Upon longitudinal section the true nature of sieve plates is apparent and they are found to be yellowish perforated partitions between cells of a verti-

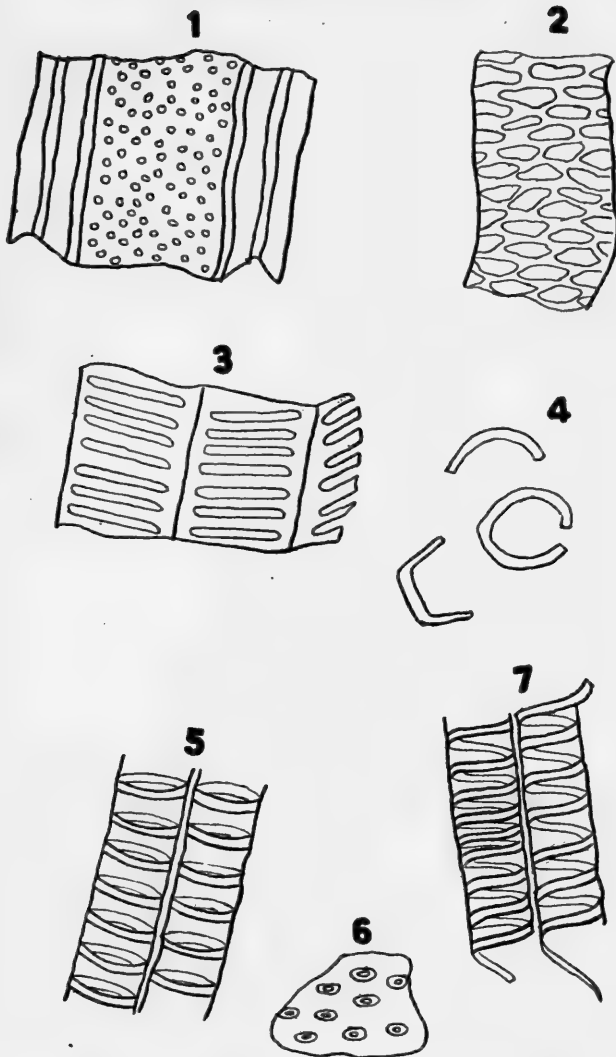

PLATE 45.—Conducting Tissue. Ducts or Vessels.

1. Quassia wood. (Pitted type.) 2. Taraxacum root. (Reticulate type.)  
 3. Sarsaparilla root. (Scalariform type.) 4. Stramonium leaf. (Fragments of spiral vessels.) 5. Pumpkin stem. (Annular type.) 6. Belladonna root. (Pitted, with bordered pores.) 7. Pumpkin stem. (Spiral type.)

cal row (Plate 46, No 1). The older sieve plates are apt to show extremely thick perforated end walls and may contain triangular patches of solidified cell contents. The walls of sieve tubes are composed of cellulose showing no traces of lignification. In general, the sieve tubes conduct materials away from the leaves, the substances transported including nitrogenized nutrients and carbohydrates in solution.

**Medullary Rays.**—The ducts and sieve tubes provide means for the transportation of materials up and down the stem, and in younger plants communicate directly or indirectly with all the cells. As the stem increases in thickness it becomes necessary to provide conducting tissues to transport nutrients to the cells located at some distance from the narrow zone in which the ducts and sieve tubes are placed. This work of lateral conduction is performed by medullary ray cells which extend from the cambium into the bark on one side and into the woody tissues on the other. The first medullary rays are strips of the original parenchyma between the vascular bundles formed in the pterom region, and they extend from the center of the stem to the inner layers of bark without interruption except in the cambium zone. These primary rays are soon supplemented by secondary rays resulting from the formation of new vascular bundles in the widest primary rays. The walls of medullary ray cells are usually thin and are composed of cellulose. In many instances the cellulose walls show numerous pores, thus increasing the efficiency of the ray cells as distributing elements. In the non-porous type of ray cells materials are transported from one cell to another by dialysis through

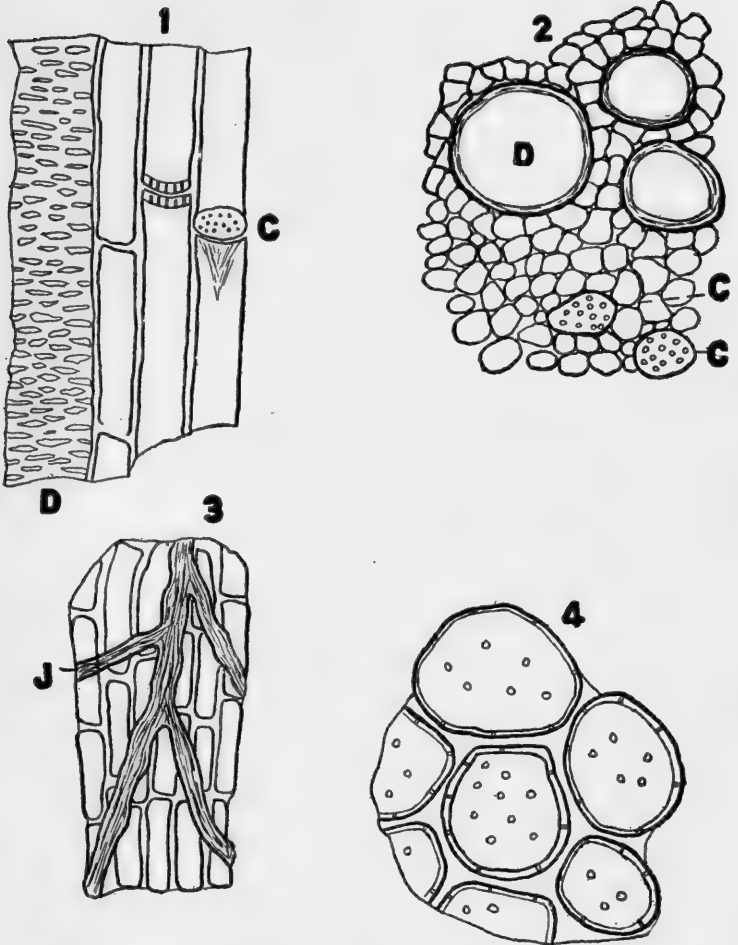

PLATE 46.—Conducting Tissue.

1. Sieve tubes. (Longitudinal view. *D*=duct. *C*=sieve-plate.) 2. Sieve tubes. (Transverse view. *D*=duct. *C*=sieve-plate.) 3. Latex tubes (*J*), *Taraxacum* root, longitudinal view. 4. Porous parenchyma, Peppermint stem pith.

the thin walls. Medullary rays are arranged in groups or bundles, each of which consists of a number of individual ray cells. Upon different aspects these ray groups present striking differences in appearance; and one can readily determine the direction in which a specimen has been sectioned by differences in the appearance of ray cells. Seen in tangential sections, the bundles appear to be elliptical and composed of nearly circular cells (Plate 61*B*). Upon radial view the bundles appear as wide strips made up of large rectangular cells (Plate 61*A*). Upon transverse section the bundles appear as narrow strips composed of one to five rows of rather long rectangular cells (Plate 60). In powdered materials the rays are usually seen on radial view. The contents of medullary ray cells include water, starch, crystals, resins and tannins.

**Latex Tubes.**—In certain families of plants conducting tissues known as latex tubes are present. These structures contain and transport a milky juice and derive their name from this fact. Latex tubes are uninterrupted tubular structures which extend through the various tissues of certain plants. They may attain great length, are considerably branched and are non-porous (Plate 46, No. 3). The exact function of this milky juice or latex is not clear. As the juice is usually acrid and purgative it may be a means of protection against animal attacks. The latex coagulates upon exposure to air and effectually seals wounds in plant tissues. Digestive enzymes are contained in the latex of certain plants, notably *Carica Papaya*, which contains the proteolytic ferment, papain. The latex tubes are best viewed in longitudinal sections and appear as irregularly branching



structures extending through the parenchymatic tissues. The contents of latex tubes may become brown in the preparation of specimens and this coloration aids in tracing the course of the vessel. The walls are very thin and are composed of cellulose.

**Porous Parenchyma.**—The parenchymatic tissues of the plant may aid in the distribution of nutrients by reason of the fact that nutrients in solution readily dialyze through their thin cellulose walls. Parenchyma cell walls, especially those in the pith or central region of the plant are usually perforated (Plate 46, No. 4); and the transfer of liquids through these cells is fairly rapid.

#### FIBRO-VASCULAR TISSUES

As the tissues concerned in the transportation of nutrients are usually delicate structures, they are supported by fibrous elements. Each group of vessels, with the adjacent mechanical or supporting tissue, is termed a fibro-vascular bundle. As previously noted in Chapter VI, the fibro-vascular bundles may be complete or incomplete. The complete bundles consist of xylem, phloem and cambium elements, whereas the incomplete bundles consist of either xylem or phloem tissues, cambium arcs being absent. The xylem bundles consist of a vascular element, ducts or vessels, supported by a fibrous element, xylem or wood fibers. The phloem bundles likewise consist of a vascular element, sieve tubes, supported by a fibrous element, bast fibers.

The tissues composing a fibro-vascular bundle may be arranged in any one of several different ways. Because of these differences in arrangement, five types

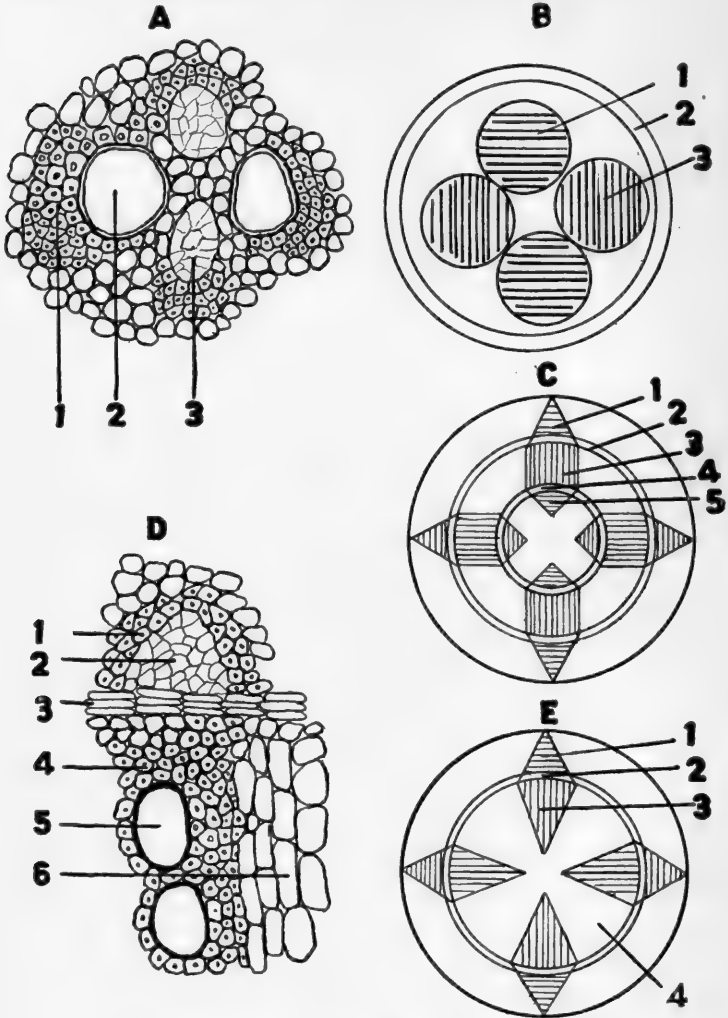

PLATE 47.—Fibrovascular Bundles.

- A. Collateral type, Bamboo stem. 1. Fibrous tissue. 2. Ducts. 3. Sieve.  
 B. Collateral Bundle, arrangement of fibrovascular elements. 1. Xylem. 2. Endodermis. 3. Phloem.  
 C. Bicollateral Bundle, arrangement of fibrovascular elements. 1. Phloem. 2. Cambium. 3. Xylem. 4. Cambium. 5. Phloem.  
 D. Open collateral type, Aconite tuber. 1. Bast fibers. 2. Sieve cells. 3. Cambium. 4. Wood fibers. 5. Ducts. 6. Medullary ray.  
 E. Open Collateral Bundle, arrangement of fibrovascular elements. 1. Phloem. 2. Cambium. 3. Xylem. 4. Medullary ray.

of bundles are recognized. *Radial fibro-vascular bundles* are always incomplete, consisting of xylem or phloem. They are further characterized by the arrangement of xylem or phloem elements in a circle within the endodermis, and the alternation of each xylem bundle with a phloem bundle. Radial bundles are found in all young roots and may even be present in mature monocotyledonous roots. They are an indication of primary structure in those plant parts in which they occur. *Concentric fibro-vascular bundles* are complete bundles consisting of xylem and phloem. They are characterized by the arrangement of xylem and phloem elements in such a way that one of these surrounds the other. Most frequently the xylem surrounds the phloem, and the bundles are scattered irregularly in a central pith region within the endodermis. This type of bundle occurs only in monocotyledonous roots and stems. *Collateral fibro-vascular bundles* are of the complete type and show xylem and phloem elements, together with cambium arcs. There are three types of collateral bundles, closed collateral, open collateral and bi-collateral. *Closed collateral bundles* consist of a xylem portion and a phloem portion separated from each other by a short strip of cambium, the whole being surrounded by a sheath or layer of fibrous tissue. The bundles may be scattered irregularly in the pith and, as a rule, are only present in monocotyledonous rhizomes or stems. *Open collateral bundles* consist of xylem elements within a cambium zone and phloem elements on the outer side of the cambium. When occurring in roots, this type of bundle may represent secondary development of the primary radial bundles.

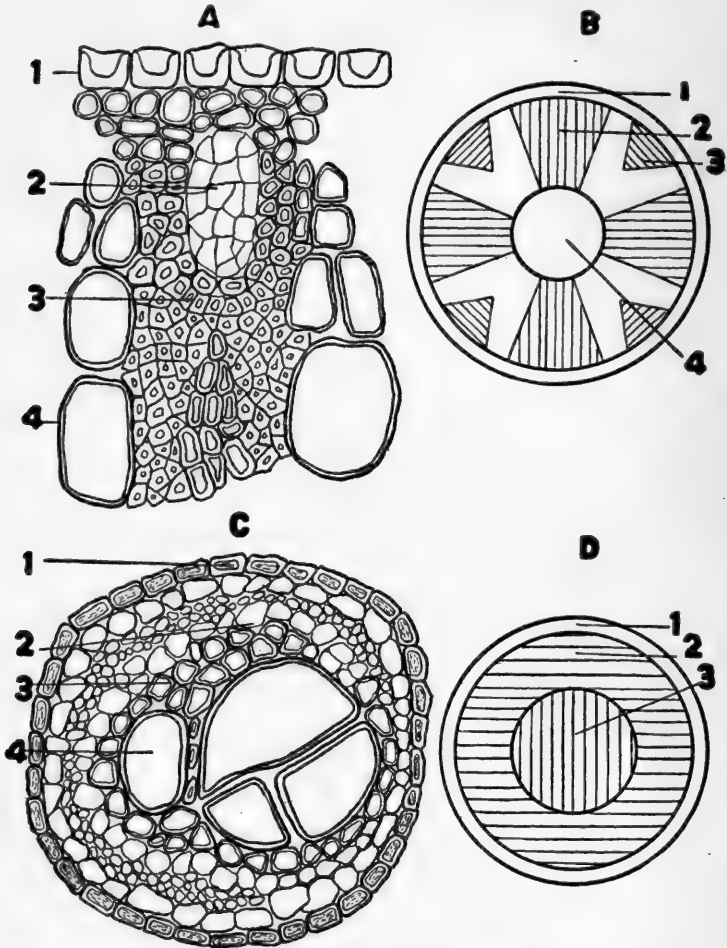

PLATE 48.—Fibrovascular Bundles.

A. Radial type, Sarsaparilla root. 1. Endodermis. 2. Sieve surrounded by bast fibers. 3. Wood fibers surrounding sieve and ducts. 4. Ducts.

B. Radial Bundle, arrangement of fibrovascular elements. 1. Endodermis. 2. Xylem. 3. Phloem. 4. Pith.

C. Concentric type, Fern rhizome. 1. Endodermal sheath. 2. Sieve surrounded by small parenchyma. 3. Fibrous tissues. 4. Ducts.

D. Concentric Bundle, arrangement of fibrovascular elements. 1. Endodermal sheath. 2. Phloem. 3. Xylem.

In stems, this type of bundle may be completely developed even in the primary stages of growth. The open collateral bundle is the type most frequently found in mature dicotyledonous roots and stems. *Bi-collateral fibro-vascular* bundles consist of a xylem element with associated cambium and two phloem elements, one on each surface of the xylem. This type of bundle is present in but few mature dicotyledonous roots and stems.

The various types of fibro-vascular bundles are illustrated in Plates 47 and 48. The arrangement of the different elements in each type of bundle is represented in the diagrams accompanying these illustrations.

## CHAPTER XI

### TISSUES FOR SYNTHESIS, ASSIMILATION AND STORAGE

THE plant possesses the power of building up the very simple chemical compounds absorbed through the root hairs and stomata into nutrients of complex composition. In other words, the plant must construct its nutrients before assimilating them. This procedure is quite different from the nutrition process in animals, as the food materials of the latter consist of complex nutrients which undergo analytic changes in the organism.

#### SYNTHESIS OF NUTRIENTS

Synthetic processes occur in many organs of the plant; but the most important are those occurring in the leaves and green stems. Starch is the most important plant nutrient; and, as chloroplasts are responsible for its formation, the synthesis of this substance occurs only in the green parts of the plant. As the chemical changes occurring in the formation of starch are initiated by, or are dependent upon, the action of light rays, the process is termed a *photosynthesis*. The crude materials entering into the formation of starch are water and carbon dioxide. These simple substances are built up into the complex starch molecule by the chloroplasts. There is much

controversy over the exact chemical reactions involved, and the two sets of reactions given represent possibilities rather than actualities.

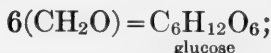
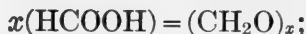
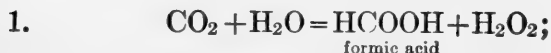

In the first set of reactions formic acid is formed from carbon dioxide and water. An unknown number of molecules of this acid is transformed into a substance having the formula of a typical carbohydrate  $(\text{CH}_2\text{O})$ . This carbohydrate substance, by rearrangement of the elements composing it, is transformed into glucose. The glucose is converted into starch by the elimination of a molecule of water. The second reaction assumes a direct formation of starch from the carbon dioxide and water with the liberation of oxygen. The weight of opinion inclines toward the building up of a series of intermediate compounds as indicated in the first reaction. Chloroplasts and light are essentials in both reactions.

Although the exact nature of the chemical changes occurring in the construction of starch substance are in doubt, the manner in which the starch granule is built up by the chloroplast is fairly well understood. The chloroplasts are protoplasmic cell con-

tents and appear as small oval disks of about constant size. Each chloroplast owes its green color to the substance *chlorophyll*. The chloroplasts are found in the inner tissues of the leaf, being especially numerous in the cells immediately beneath the epidermal membrane. The starting point in the formation of a starch grain by the chloroplast is the appearance of a small projection or bud upon the latter. This projection increases in size as the starch substance is deposited around it, and may become much larger than the chloroplast. The newly formed starch grain may or may not become detached from the chloroplast. In daylight the formation of this *assimilation starch* by the chloroplasts proceeds with great rapidity, and and the starch must be removed from the place of synthesis to make room for further production. Starch is a colloidal or non-dialyzable substance; therefore, before it can pass through the cell membranes of the leaf tissues, it must be converted into a soluble or dialyzable form. Enzymes present in the leaf cells dissolve the newly formed starch, converting it into *soluble starch* which can dialyze through the cell walls. This soluble starch is transported by the conducting tissues to different parts of the plant where it is used as a nutrient or stored against future needs.

Frequently the greater part of the soluble starch is stored in well-protected parts of the plant. The soluble starch or glucose transported from the leaves may be stored in the form of reserve starch, inulin, sucrose, glucosides or cellulose. The leucoplasts take part in the formation of storage or *reserve starch* from the soluble starch, and the process is somewhat similar to that occurring in the formation of assimilation



**starch.** A bud appears upon the surface of the leucoplast, and the soluble starch is deposited in successive layers around this bud. The starch grain increases in size, becoming larger than the leucoplast and may finally be detached from the latter. Certain markings upon the starch grain have direct connection with the processes of formation. The first part of the starch grain to be produced is termed the *hilum* and is often of characteristic form. The different layers deposited around the hilum are often apparent through the presence of *striations* or markings upon the face of the grain. One or several starch grains may be developed from one leucoplast, thus giving rise to *simple* and *compound* forms. Several types of starch grains are illustrated in Plate 51.

**Inulin,** instead of reserve starch, is formed from the soluble starch or carbohydrate in a few families of plants. Inulin is a reserve material and is probably merely deposited in the cells, the leucoplasts taking no part in the process.

**Sugars.**—The formation of sucrose or cane sugar from the soluble starch or glucose takes place in the stems of sugar cane and the roots of the sugar beet. Sucrose is a reserve material and is merely crystallized from the cell sap of the cells in which it occurs.

**Aleurone.**—Little information is available on the formation of the albuminous or nitrogenized nutrients of plants. They are possibly formed by interaction between the soluble carbohydrates produced in the leaves and the soluble inorganic salts absorbed through the root hairs. This synthesis may be carried out in the leaf cells and in the meristematic regions of the plant. *Aleurone* is a nitrogenized reserve material

and is usually stored in those seeds which contain large amounts of oil but are lacking in starch. In the synthesis of nitrogenized nutrients oxalic acid is formed, and this poisonous substance must be disposed of. The oxalic acid reacts with the calcium salts present, resulting in the formation of calcium oxalate, which because of its insolubility is practically harmless. Calcium oxalate occurs in various crystalline forms and is of service in the identification of certain vegetable materials. By complex and little understood syntheses, hydrocarbon nutrients may possibly be produced from soluble starch.

**Glucosides** are substances which, upon digestion with dilute mineral acids, readily decompose, yielding glucose as one of the products of the reaction. Many glucosides are extremely poisonous and, aside from the fact that they may protect the plant against animal attacks, little is known of their exact function in the plant economy.

The soluble carbohydrates may be transformed by substances within the cell into reserve cellulose. The reserve cellulose is deposited upon the original thin cellulose wall of various cells, resulting in the formation of collenchymatic tissue.

#### SECRETING CELLS AND CAVITIES

Secreting cells are concerned in the synthesis of resins, gums and volatile oils. While these substances are formed from the products of assimilation they are not as intimately concerned in the nutrition of the plant as are the substances noted in the preceding section. The plant tissues performing this

function of secretion include glandular hairs, the walls of secretion cavities, individual secretion cells and oil ducts.

**Glandular Hairs.**—The histological forms which glandular hairs may assume have been described in the section on Plant Hairs (Chapter VII). Glandular hairs are outgrowths of the epidermal tissues and possess glands consisting of one or more cells, which have the power of secreting or producing volatile oils or resins. In some instances, the gland cavities are formed by a separation of a thin membrane from the upper surface of a number of modified epidermal cells; in others no special cavity is apparent, and the secretions are evidently stored within the gland cells. Glandular hairs may occur on leaves, herbaceous stems and the petals of the flower. The secretions include volatile oils, resins or oleoresins.

**Secretory Cavities.**—Secretory cavities may occur in the internal tissues of leaves, barks, roots, woods, fruits and seeds. According to the manner of their formation they are subdivided into schizogenous and lysigenous types. *Schizogenous cavities* are formed through enlargement of the intercellular spaces in the region adjacent to the secreting cells (Plate 49, No. 2). The secretory products dialyze into the intercellular space and cause distention of the latter. The mature schizogenous cavity appears to be completely surrounded by a layer of secreting cells. *Lysigenous cavities* result from the disintegration of a group of secretory cells. This is brought about through distention of the secreting cells by accumulated secretions. The cells finally burst and discharge their contents into a common cavity (Plate 49, No. 1).

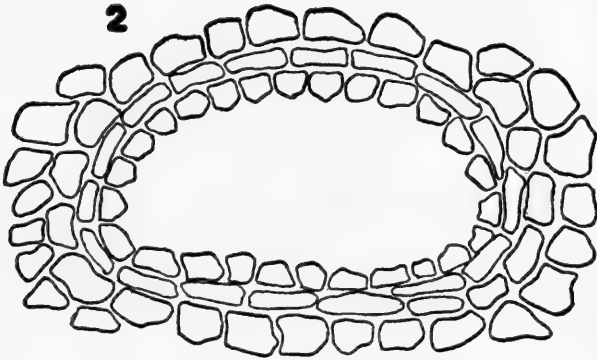
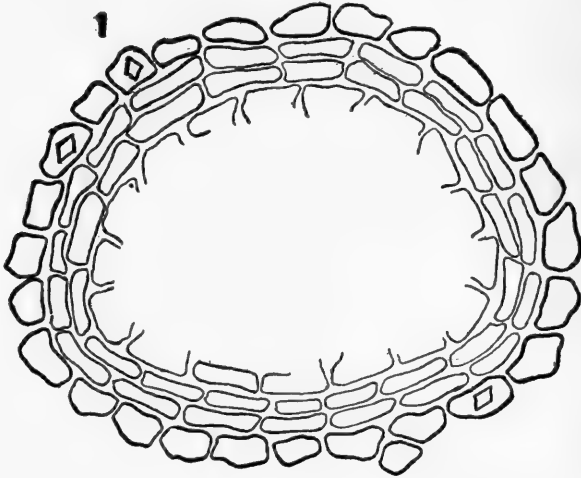

PLATE 49.—Secretion Cells.

1. Lysigenous cavity, Orange peel. 2. Schizogenous cavity, White Pine bark.

Lysigenous cavities usually show traces of the partially disintegrated cells in the form of projecting fragments of wall.

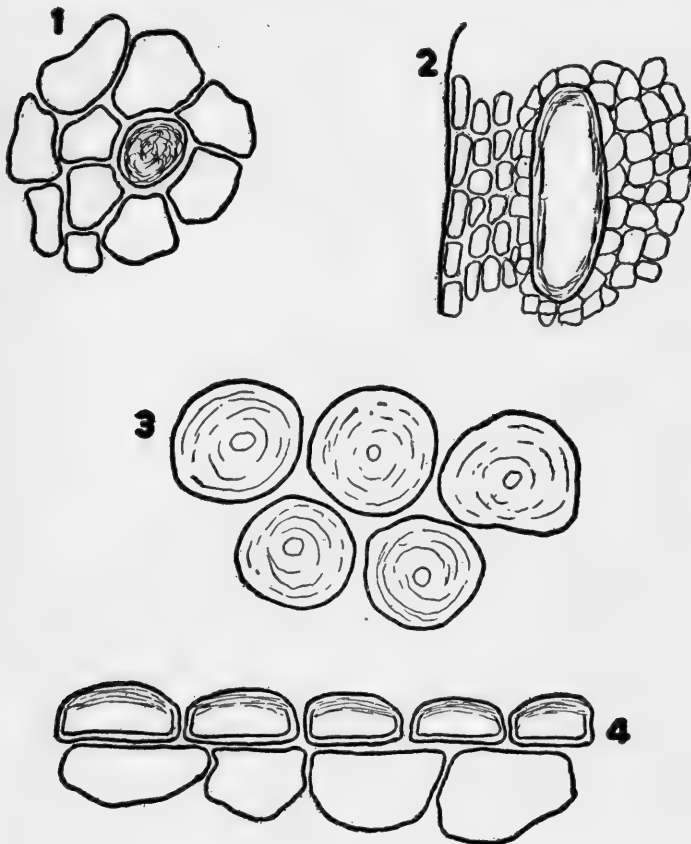

PLATE 50.—Secretion Cells.

1. Unicellular secretion cells, Galangal rhizome. 2. Vittae, secretion cavities, Fennel fruit. 3. Mucilage cells, Mustard seed. (Surface view.) 4. Mucilage cells, Mustard seed. (Sectional view.)

**Unicellular Secretion Cells.**—Individual cells may function as secreting organs. Unicellular secretion cells differ from secretion cavities and oil ducts in

that the secretion remains within the individual cell and is not stored in a special cavity (Plate 50, No. 1). Secretion cells may show but little differences in size and form from the surrounding cells, except as the secretion displaces the protoplasmic contents or accumulates and distends the cell walls. In certain types of unicellular secretion cells, the secreted products are apparently stored within sacs especially formed for the purpose. The materials produced by these cells include oils and oleoresins.

**Vittae.**—Oil channels or vittae are especially characteristic of the Umbelliferous fruits. They are located in the fruit parenchyma or mesocarp and appear as irregular duct-like structures extending the full length of the fruit. (Plate 50, No. 2). The number of vittae present is a diagnostic character of interest in the differentiation of closely related species. Volatile oils are the most important products secreted by these oil ducts.

#### STORAGE TISSUES

The period of greatest activity in the manufacture of nutrients is the summer season. Perennial plants must lay by a store of food to carry them over the winter months in which the production of nutrients practically ceases. The tissues concerned in storing nutrients include parenchyma cells, secretion cavities, collenchyma cell walls and the cavities of fibers and stone cells.

**Parenchyma.**—The parenchyma cells of the cortical and pith regions are the chief storage places for plant nutrients. Mention has already been made of the formation of starch in the parenchyma cells by the

leucoplasts. This reserve starch is stored in the parenchyma of well-protected parts of the plant. Inulin is similarly stored in the parenchyma of tubers and roots. Alkaloids and calcium oxalate crystals may also be stored in the parenchyma cells, while tannins are frequently found in bark parenchyma cells.

**Secretion Cavities.**—The volatile oils or other products of secretory cells are usually stored in cavities of lysigenous or schizogenous types or may be contained in the gland cells.

**Collenchyma Cell Walls.**—The walls of many cells, especially those of seeds and fruits, are thickened by deposition of cellulose. This cellulose may be classed as a reserve nutrient and may possibly be converted into assimilable form if required. Collenchyma is thus a tissue of synthesis, a supporting tissue and a storage tissue.

**Cavities of Stone Cells and Fibers.**—Storage of nutrient material within the cavities of stone cells and fibers occurs in comparatively few instances. Materials stored in these thick-walled cells are not as readily available for use as nutrients as are those contained in the thinner-walled parenchyma.

## CHAPTER XII

### CELL CONTENTS

CELL contents, or substances resulting from the activity of the protoplasm, may be classified according to their chemical constitution and also according to their structure or form. Classifications based upon structure or form are better adapted to histological work than those founded solely upon chemical characters. The classification which follows is based primarily upon structural characters, and chemical differences are used as a secondary point in the grouping.

#### Cell Contents of Definite Form.

##### Colloidal Group:

- Starch
- Inulin
- Aleurone

##### Crystalline Group:

- Sugars
- Alkaloids
- Glucosides
- Calcium Oxalate

#### Cell Contents of Indefinite Form.

##### Colloidal Group:

- Tannins
- Gums
- Resins
- Fats and Oils
- Silica Deposits
- Calcium Carbonate Deposits



**Starch.**—The transitory or assimilation forms of starch described in Chapter XI are of little importance in food and drug microscopy. Reserve or storage starch grains are fairly constant for a given plant and are of importance in identification work. Starch grains may be classified according to the following characters:

- Number of grains in the mass;  
single or compound.
- Shape or form of the grains;  
circular, oval and angular forms.
- Position of the hilum;  
centric or excentric.
- Shape or form of the hilum;  
point, line and stellate forms. .
- Presence or absence of striations;  
striated and non-striated forms.
- Size of the grains;  
ranging from 2 to 100 microns.

The leucoplast produces either single starch grains or masses consisting of several grains. In the latter instance the cluster is termed a *compound grain*. The shape or form of a starch grain depends upon the number of grains developed from each single leucoplast. The parts of a compound grain are usually angled because of the presence of surrounding grains which exert pressure on all sides. Grains developed in groups of two or three will be flattened on the sides in contact with other grains and rounded on the free surfaces. *Beaked* forms show a small projection at the hilum end of the grain.

Starch grains of a given plant range in size within fairly constant limits. In stating the sizes of compound grains, the component parts as well as the whole mass should be considered. Compound grains in powdered

materials are always more or less broken, and it may be difficult to secure satisfactory views unless one examines sections.

The position of the hilum is dependent upon the manner in which the grain is formed by the leucoplast and upon the portion of the grain viewed by the observer. In view of the latter fact one cannot readily determine the position of the hilum in materials examined in temporary mounts until the particles have come to rest.

The form of the hilum may be modified by the amount of moisture in the grain. Fissures may arise from a *point hilum* through drying. A *stellate hilum* shows several radiating fissures. A *line hilum* is formed by a straight fissure arising from the hilum. A *V-shaped hilum* results from the formation of two straight fissures from the hilum.

Striations, when apparent, always encircle the hilum, and are best observed in water mounts. A number of typical starch grains are illustrated in Plate 51.

**Inulin.**—This substance occurs in flat tabular masses, in spheroidal masses and in forms closely resembling starch grains. The tabular forms are usually much broken and very irregular (Plate 52, No. 2). Inulin grains or masses do not possess a hilum nor do they show striations. The spheroidal and starch-like forms may show fissures extending from the center of the mass (Plate 52, No. 1).

**Sugars.**—The sugars contained in plant cells are usually in solution and are therefore not visible unless the cell liquids become so concentrated that crystallization takes place.

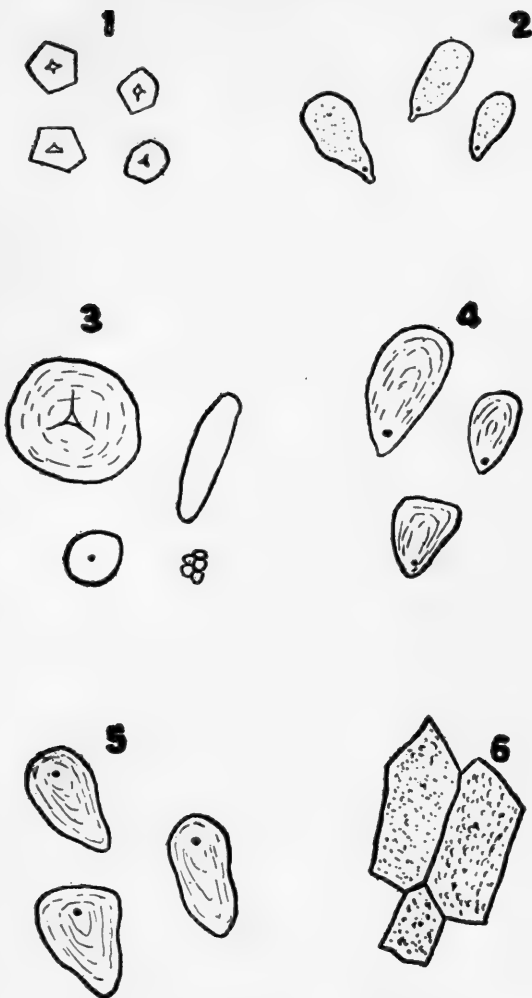

PLATE 51.—Cell Contents. Starch Grains.

1. Corn starch. (Angled grains, centric stellate hilum.) 2. Ginger starch. (Beaked grains, excentric point hilum.) 3. Rye starch. (Circular grains, centric fissured and point hilum.) 4. Potato starch. (Ovoid grains, excentric point hilum.) 5. Maranta starch. (Ovoid grains, excentric point hilum.) 6. Pepper starch. (Compound grains.)

**Alkaloids.**—The alkaloids are seldom visible in plant cells and their presence is usually demonstrated by the addition of mineral acids which form crystalline salts.

**Glucosides.**—Glucosidal substances may or may not be visible in plant cells without special treatment. Those glucosidal substances which do occur in visible form show such great variations in character that general descriptions cannot be given. The deposits of the glucoside, hesperidin, in buchu leaves are illustrated in Plate 52, No. 3.

**Calcium Oxalate.**—This material may occur in almost any part of the plant and, with the exception of starch, is perhaps the most important cell content from the standpoint of the analyst. Calcium oxalate occurs in needles, rosettes and various other crystalline forms. The types of crystals recognized are acicular, rosette, prismatic and micro-crystals (cryptocrystalline crystals). *Acicular* or *needle-like crystals* may occur singly or in bundles termed *raphides*. *Rosette crystals* are aggregates of small prismatic forms. The *prismatic* forms of calcium oxalate are modifications of the monoclinic and tetragonal systems. Perfect crystals are the exception rather than the rule, although those of cubical or monoclinic form may be fairly symmetrical. *Micro-crystals* are the smallest type of plant crystal, and, although they are usually plentiful when present, are often difficult of recognition because of their small size. These crystals occur as triangular prisms and appear as V-, Y- and T-shaped forms, according to the crystal angles exposed to view. *Crystal sand* consists of minute micro-crystals or the broken fragments of

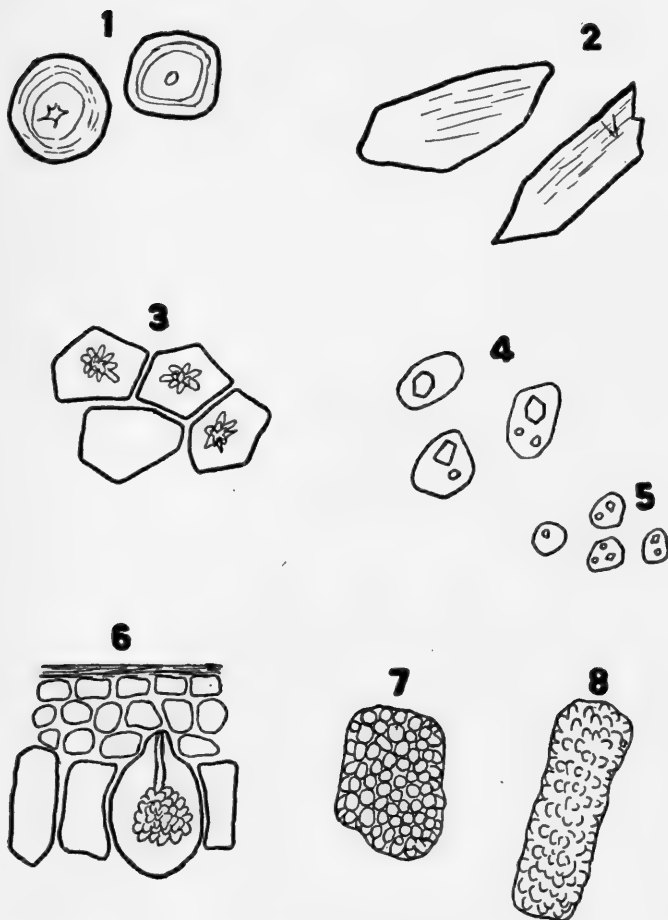

PLATE 52.—Cell Contents.

1. Inulin, spheroidal masses from Dahlia root. 2. Inulin, tabular masses from Echinacea root. 3. Hesperidin, deposits in epidermal cells, Buchu leaf. 4. Aleurone, Ricinus seed. 5. Aleurone, Mustard seed. 6. Cystolith, in subepidermal cells, Ficus leaf. 7. Cystolith, Nettle root. 8. Cystolith, Ruellia root.

larger crystals, and occurs in many powders. In materials containing sand or earth, care must be taken not to confuse crystalline quartz particles with calcium oxalate crystals. Various types of plant crystals are illustrated in Plate 53.

**Tannins.**—These materials occur as brownish or blackish masses without characteristic form.

**Gums.**—The gum deposits may fill the entire cell and are usually observed by examining the material in an aqueous mounting medium which causes swelling of the contained gum. The mucilage formed upon the addition of water appears in the form of highly refractive globules, which remain light colored after the diaphragm is closed (Plate 50, Nos. 3 and 4).

**Resins.**—Resin deposits in plant cells differ greatly in color and lack characteristic form.

**Fats and Oils.**—These substances appear as highly refractive globules which may be mistaken for air bubbles in well-lighted fields. When the diaphragm is closed, the outer margin of an air bubble increases in thickness, while that of an oil globule does not.

**Silica Deposits.**—This material occasionally occurs in epidermal and fiber cells. The deposits appear as white, spherical bodies with numerous small spines or projections upon their surface.

**Calcium Carbonate.**—This substance appears in grayish masses of indefinite form and may possibly be mistaken for compound starch grains. The deposits are termed *cystoliths* and are composed of numerous small globular particles of carbonate (Plate 52, Nos. 6, 7, 8). Aside from the absence of a hilum in the small globules forming the masses, they may be dis-

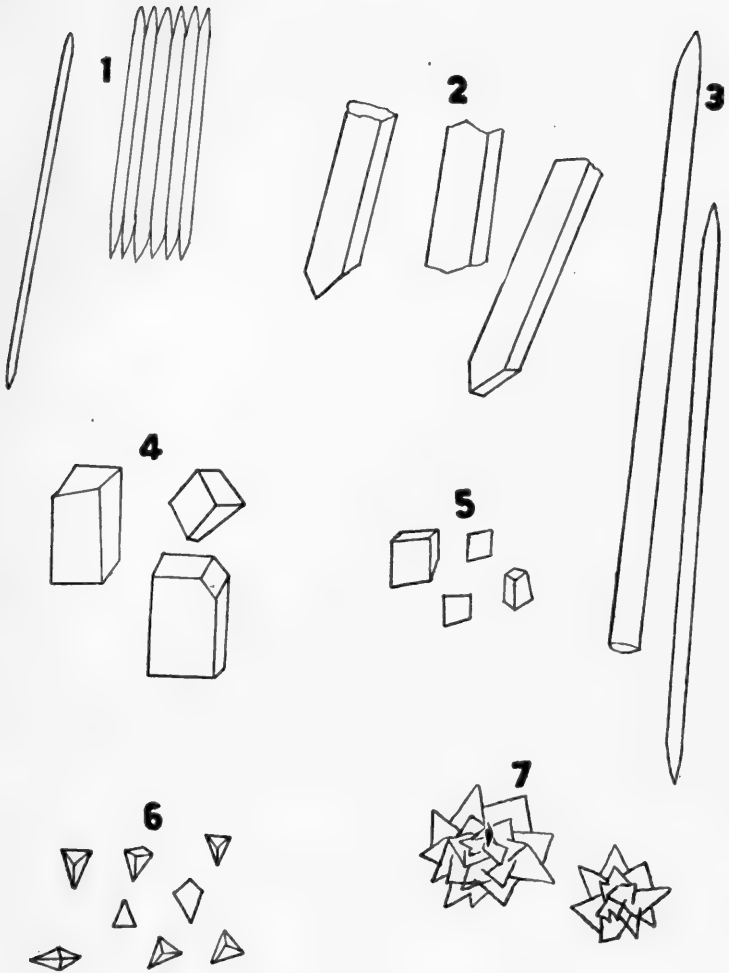

PLATE 53.—Cell Contents.

1. Acicular crystals, single and in raphides, Sarsaparilla root. 2. Prismatic crystals, Orris root. 3. Acicular crystals, Squill. 4. Prismatic crystals, Prunus bark. 5. Cubical crystals, Senna leaf. 6. Cryptocrystalline crystals, Belladonna root. 7. Rosette crystals, Euonymus bark.

tinguished from starch by their solubility in mineral acids with liberation of carbon dioxide.

**Aleurone.**—Aleurone granules occur in several different forms and may closely resemble small starch grains. A form frequently seen consists of globular bodies, each containing one or more crystalline structures, or having the latter attached to the outer edge of the grain. Other forms show globular bodies within the grain or attached to its outer edge. The iodine reaction may be used to distinguish between starch and aleurone grains, as the latter become brown upon addition of the reagent. Various types of aleurone grains are illustrated in Plate 52, Nos. 4 and 5.



## CHAPTER XIII

### ROOT STRUCTURES

IN considering the histology of roots it is noted that the roots of many classes of plants undergo the changes noted in Chapter VI, resulting in the development of secondary or permanent tissues. Other types of roots do not undergo this series of changes incidental to the production of secondary structures. Therefore it is convenient to subdivide root structures into those found in secondary roots and those present in primary roots. The roots of most monocotyledons retain their primary structures throughout the life of the plant. Dicotyledonous roots, while exhibiting primary structures during the earlier stages of growth soon undergo modification resulting in the formation of secondary structures. The chief differences between the primary and secondary types of roots are in the nature of the covering tissues, the arrangement of the fibro-vascular bundles, and the presence or absence of a distinct endodermal layer.

#### PRIMARY ROOT STRUCTURES

Primary root structures are present in the earlier stages of root development of both monocotyledons and dicotyledons; but, in the former class of plants, primary structures are retained throughout the life of the individual. The tissues usually present in roots

of primary structure and the order in which they occur, beginning at the outermost layer, are as follows:

1. Epidermis,
2. Hypodermis,
3. Cortical parenchyma,
4. Endodermis,
5. Phloem bundles,
6. Xylem bundles,
7. Pith parenchyma.

By reference to Plate 54 it will be seen that each of these tissues possesses certain structural characteristics and fairly definite cell contents whereby it may be distinguished from the others even when the material is finely powdered. In the identification of unknown samples of roots, it is important to determine whether the material is from a monocotyledonous or a dicotyledonous plant. It is extremely unlikely that the younger dicotyledonous roots showing primary structure would be present in such material. Therefore the presence of primary tissues in vegetable substances is a fairly certain indication that the material is from a monocotyledonous plant.

#### CHARACTERS OF THE PRIMARY ROOT TISSUES

**Epidermis.**—The epidermal cells of mature primary roots are usually darker colored than the other tissues. Root hairs or peripheral elongations of the epidermal cells are often present. These structures are integral parts of the epidermal cells and must not be confused with trichomes or plant hairs occurring on over-ground portions of the plant. The root hairs are usually slightly colored, like the epidermal cells, and are extremely thin-walled so as to permit ready

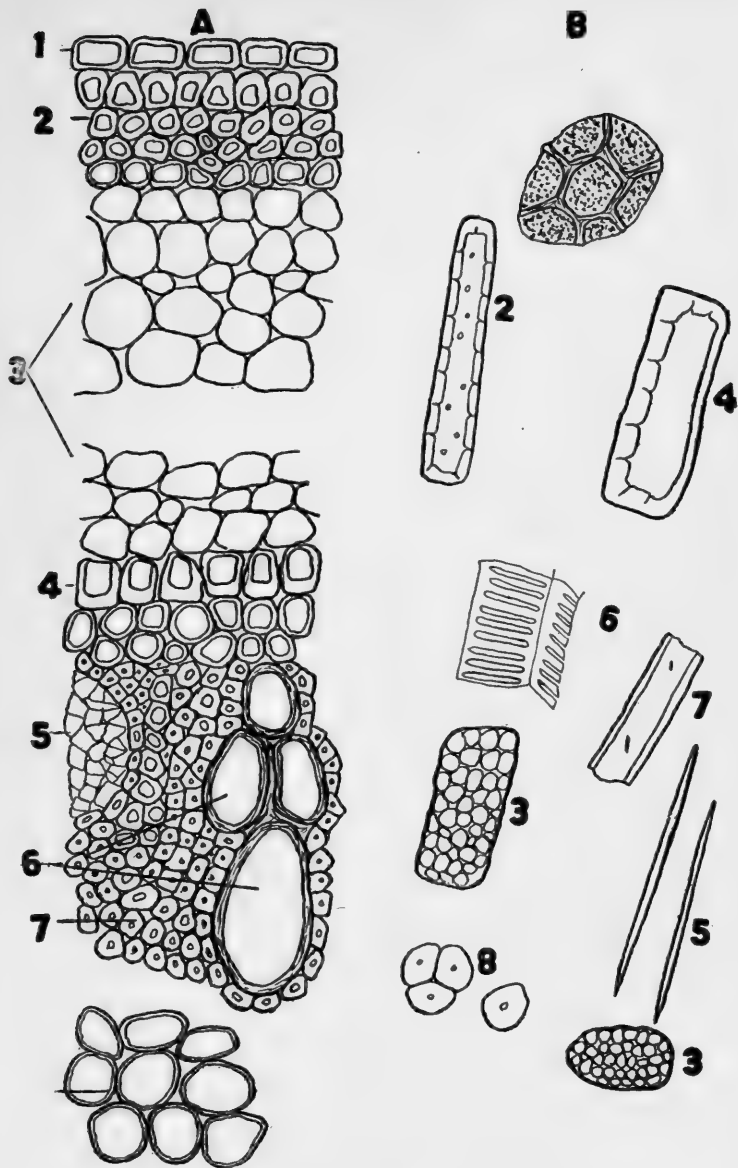

PLATE 54.—Primary Root Structure.

A. Transverse Section, Sarsaparilla root. 1. Epidermis. 2. Hypodermis. 3. Cortical Parenchyma. 4. Endodermis. 5. Sieve tubes. 6. Ducts. 7. Fibers. 8. Pith.

B. Powdered Sarsaparilla root. 1. Epidermis. 2. Hypodermis. 3. Parenchyma, longitudinal and transverse views, cells filled with starch. 4. Endodermis. 5. Acicular crystals. 6. Scalariform vessels or ducts. 7. Fibers. 8. Starch grains, single and compound.

absorption of dialyzable materials. The epidermis is seldom more than one layer of cells in thickness, and the cells are not strongly cutinized as are those of the green portions of the plant. As illustrated in Plate 54, epidermal cells in sectional view appear in more or less rectangular or oblong forms. They are rather thin walled, excepting upon exposed surfaces, which may show slight thickening. On surface view, which is the most frequently had when examining powdered materials, epidermal cells show rectangular and polygonal forms.

**Hypodermis.**—The hypodermal layer occurring in primary roots is immediately within the epidermis; and the individual cells are usually slightly colored. This tissue may be one or more layers of cells in thickness, but the number of cell layers seldom exceeds five. The hypodermal tissue is partly a covering tissue; it normally assumes this function in certain plants and may assume it in others if the epidermis is injured. Hypodermal cells, as seen in transverse section, are usually angled and possess uniformly thickened walls. In longitudinal sections and in powdered materials, these cells appear rather long and similar to fibers, except for the fact that their end walls are blunt or square.

**Cortical Parenchyma.**—The primary cortex is bounded on the outside by the hypodermis and on the inside by the endodermis. The cortical cells represent the original parenchymatic tissue of the periblem region, and undergo but little change during the growth of the root. The cortex is usually several layers of cells in thickness; and within these cells much of the nutrient material of the plant is stored.

The individual cells are thin-walled and irregularly circular in outline, when seen in the transverse section.

Viewed in longitudinal section these cortical cells often appear rectangular or polygonal. In powdered materials the parenchymatic tissues may occur as rectangular, polygonal or irregularly circular cells, usually in mass and containing cell contents.

**Endodermis.**—This tissue separates the periblem tissues from those of the plerom, and is the innermost of the primary periblem tissues. The presence of endodermal tissues in a mature root is an indication of primary structure. The endodermis is very seldom more than one layer of cells in thickness and may be readily distinguished from the adjacent cellular elements. The individual endodermal cells are usually slightly colored and rectangular or polygonal in outline when viewed in transverse section. The cell walls may be uniformly thickened, or may show thickening on all sides except that toward the cortex. Thickening of these cell walls is due to deposition of suberin. In longitudinal sections or in powdered materials, the endodermal cells appear as rather long structures, resembling fibers. They differ from the latter in that one wall is thicker than the other and the end walls are blunt or square.

**Phloem Bundles.**—These tissues are developed in the parenchyma of the plerom zone and therefore are located within the endodermis. The phloem bundles occur as isolated groups of cells in the plerom parenchyma and usually alternate with the xylem bundles. Each phloem bundle consists of a transporting element (sieve cells) and a mechanical or supporting element (bast fibers). In transverse sec-

tions the sieve elements appear as groups of small very thin-walled cells in which the sieve plates or perforated end-walls may occasionally be apparent. Each group of sieve cells is surrounded by bast fibers, which, upon transverse section, appear as thick-walled angled cells with a rather small cavity or lumen. The true character of sieve cells can only be seen in longitudinal sections where they are apparent as long, thin-walled structures showing sieve plates at each end. The bast fibers on longitudinal view appear as long, thick-walled cells tapering toward each end.

**Xylem Bundles.**—These tissues are developed in the original plerom parenchyma in a manner similar to those of the phloem bundles. They are usually placed nearer the center of the plerom zone than are the phloem bundles with which they alternate. Each xylem bundle consists of transporting elements, ducts or vessels, and mechanical or supporting elements, wood or xylem fibers. In transverse section the ducts appear as large, irregularly circular, thick-walled cells, surrounded by smaller, angled, thick-walled wood fiber cells. In longitudinal view the ducts appear as continuous structures, the walls of which show markings varying according to the type of vessel. Wood fibers in longitudinal view appear as thick-walled cells, many times longer than broad and tapering toward each end.

The arrangement of fibro-vascular bundles in a circle within the endodermis is common to both primary and secondary root structures. The alternation of phloem bundles with xylem bundles, each remaining incomplete, is characteristic of the radial

type of bundle, found exclusively in roots of primary structure. It must be noted that the concentric and closed collateral types of fibro-vascular bundles are present in the primary roots of monocotyledons, so that while radial bundles indicate primary structure, not all primary roots possess radial bundles.

In powdered materials the ducts, wood fibers and bast fibers are always seen in longitudinal view. Sieve cells, being very delicate structures, are usually disintegrated during powdering and therefore are rarely apparent. The differentiation of wood fibers from bast fibers in a powdered sample is usually difficult and sometimes impossible. As bast fibers are generally longer and stronger than wood fibers, they are less likely to be broken during grinding. The lumen of a bast fiber is usually smaller than that of a wood fiber. The pores in fibers may appear as pits, or as slits extending diagonally in the wall of the fiber.

**Pith Parenchyma.**—This tissue represents the original tissue of the plerom zone. The individual cells are rather similar to the parenchyma cells of the cortex but are apt to be separated by larger intercellular spaces and to possess porous walls. The pith is in the center of the plerom region and is gradually replaced by xylem as the latter tissue increases. In monocotyledonous roots possessing bundles of the concentric and closed collateral types, there is no regular arrangement of fibro-vascular tissues, and the bundles are scattered within a central cylinder or stele. The *stele* is bounded by the endodermis and consists of the original parenchyma cells of the plerom zone.

### SECONDARY ROOT STRUCTURE

Secondary root structures are present in mature dicotyledonous plants. They represent the permanent tissues of this class of plants and are replacements of, or enlargements upon, the primary tissues previously described. The changes occurring in the transition from primary to secondary structure may be summarized as follows:

1. The primary epidermis and hypodermis are replaced by tissues originating from a phellogen or bark cambium which develops within the primary cortex.
2. The endodermis is gradually replaced by tissues developed from the cambium.
3. The incomplete primary bundles are completed by the addition of xylem tissues on the inner face of the phloem bundles and phloem tissues on the outer face of each xylem bundle.
4. Appearance of distinct medullary rays between the fibrovascular bundles.
5. Replacement of the pith parenchyma by xylem tissues.

As shown in Plate 55, the tissues usually present in roots of secondary structure and the order in which they occur, beginning at the outermost layer, are as follows:

1. Cork,
2. Phellogen,
3. Cortical parenchyma,
4. Phloem tissues,
5. Cambium,
6. Xylem tissues,
7. Medullary rays.

### CHARACTERS OF THE SECONDARY ROOT TISSUES

**Cork.**—The corky tissues which replace the primary epidermis usually consist of several layers of dark-colored cells. The individual cells are thin-walled, and may contain tannin deposits. In trans-



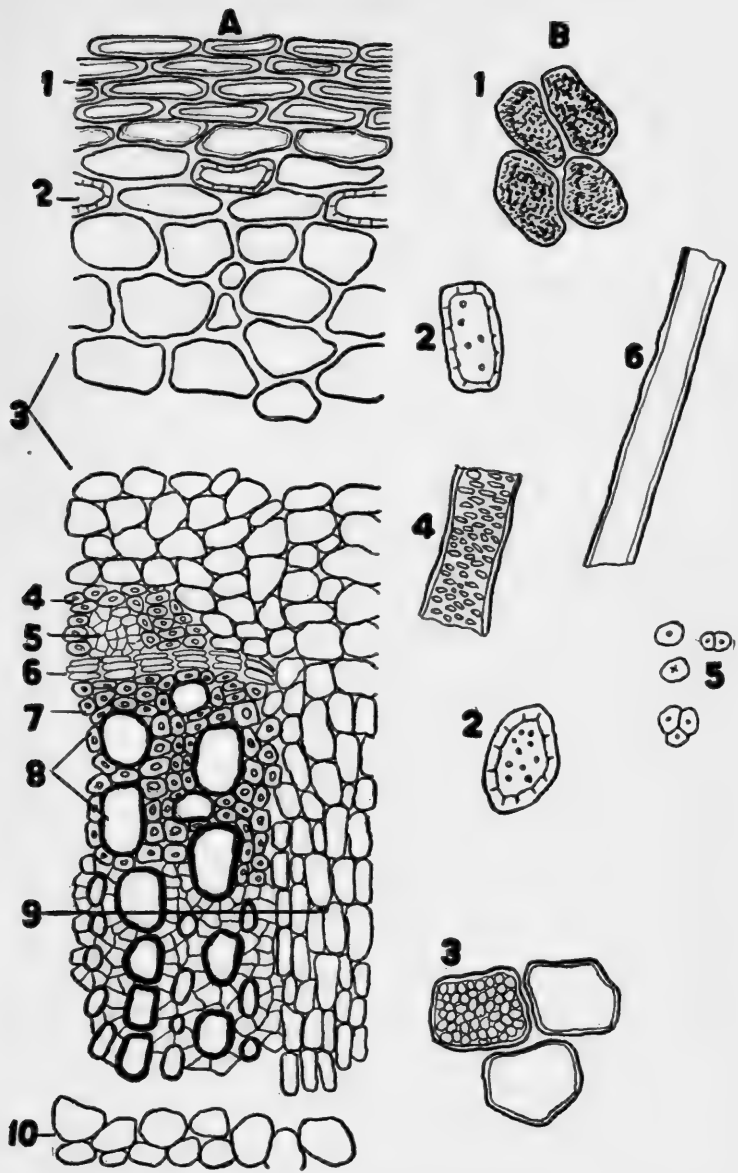

PLATE 55.—Secondary Root Structure.

A. Transverse Section, Aconite Root. 1. Cork. 2. Stone cells. 3. Cortical parenchyma. 4. Bast fibers. 5. Sieve cells. 6. Cambium. 7. Wood fibers. 8. Ducts. 9. Medullary ray. 10. Pith parenchyma (traces).

B. Powdered Aconite Root. 1. Cork. 2. Stone cells. 3. Parenchyma cells filled with starch. 4. Duct. 5. Starch grains. 6. Fiber.

verse sections cork cells appear rectangular or polygonal in outline. In surface view they are irregular in form and, because of their dark color and close contact, rarely present a clear and definite outline. In powdered materials cork cells always appear in surface view but, owing to the thickness of the fragments definite details of cell structures are seldom apparent.

**Phellogen.**—This tissue, although always present, is not easily distinguished from the cork cells and cortical parenchyma. It occupies a narrow zone immediately beneath the cork. The individual cells are rectangular in sectional view and brownish in color. As this tissue undergoes disintegration during grinding, it is never apparent in powdered materials.

**Cortical Parenchyma.**—This parenchymatic tissue is similar in every respect to the cells of the primary cortex. Occasionally sclerenchymatic tissues or stone cells are developed in the midst of the cortical cells of the root, to which they afford additional support and strength.

**Phloem and Xylem Bundles.**—These elements are similar in structure to those already described under Primary Root Tissues. It must be noted that the fibrovascular bundles of secondary structure are complete and consist of both xylem and phloem tissues. The bundles present in secondary or mature root structure are either of the open collateral type or the bi-collateral type. In the former, the xylem elements are toward the center and are separated from the phloem by a strip or circle of cambium. In the bi-collateral bundle the xylem tissue bears cambium layers on its inner and outer surfaces, and each of these in turn gives rise to a phloem group.

**Cambium.**—This tissue is meristematic, possessing the power of cell division or reproduction, and is placed between the xylem and phloem elements. The individual cells, as seen in transverse section, appear as light-colored, thin-walled, rectangular, tangentially elongated cells. The cambium zone comprises one or more layers of cells, and, although first existing in the form of detached strips attached to the primary bundles, soon forms a complete ring or circle in the root. In this manner the cambium not only bisects the bundles but also crosses the medullary rays or strips of tissue between the fibro-vascular bundles.

**Medullary Rays.**—The original medullary rays are wedge-shaped strips of plerom parenchyma between the fibro-vascular bundles. At first these strips are broad; but, owing to the development of new fibro-vascular bundles within them, they ultimately appear as narrow strips of tissue extending from the center of the root to the cortical region. The rays may be from one to five cells in width and as much as twelve cells in height. Seen on transverse section (Plate 60), the ray cells are long and rectangular with slightly thickened, porous or non-porous walls. On radial section (Plate 61A), they appear as groups of regularly arranged rectangular cells extending at right angles to the other tissues. On tangential section the rays appear as elliptical or oval patches, each of which contains several ray cells (Plate 61B). The dimensions of a medullary ray can only be determined by examining sections made in different directions. Transverse sections show the width and length, radial sections the height, and tangential sections the width and height of the medullary rays.

## CELL CONTENTS OF ROOTS

The cell contents of roots are usually stored in the parenchymatic cells. The stored materials may include most, if not all the substances mentioned in the section of cell contents. The most important contents from the histological standpoint are starch, inulin, calcium oxalate crystals and cystoliths.

## FUNCTIONS OF ROOT TISSUES

The functions of the different structures present in roots may be tabulated as follows:

Covering tissues . . . . .	{	Primary epidermis, Cork, Hypodermis.
Supporting tissues . . . . .	{	Bast fibers, Wood fibers, Stone cells, Endodermis.
Absorbing tissues . . . . .		Root hairs.
Conducting tissues . . . . .	{	Sieve tubes, Ducts, Medullary rays.
Assimilation tissues . . . . .	{	Leucoplasts in parenchyma cells, Parenchyma.
Storage tissues . . . . .		Parenchyma.
Meristematic tissues . . . . .	{	Phellogen, Cambium.

## CHAPTER XIV

### STEM STRUCTURE

PLANT stems may or may not undergo the series of changes incidental to the formation of secondary tissues. The stems and rhizomes of monocotyledonous plants usually retain the primary structures, with but slight variation, throughout life. In dicotyledons the primary structures undergo the changes consequent to the formation of secondary tissues. Herbaceous or annual stems exhibit primary structure. They last but a single season, although their rhizomes or roots may be biennial or perennial, giving origin to a new stem each season. The woody stems of most dicotyledonous plants are the result of the development of secondary structures.

#### PRIMARY STEM STRUCTURES

Primary stem structures are present in the earlier stages of stem development in both monocotyledons and dicotyledons. The dermatogen, periblem and plerom zones, to which reference has been made in the section dealing with the origin of tissues, and again in the section on root structures, are also present in the rudimentary stem. The primary tissues developed from these zones are in many respects similar to the primary tissues of roots; but several striking differences are apparent. The dermatogen

zone of stems gives rise to a primary epidermis, but does not form tissues corresponding to those of the root cap and root hairs. The primary epidermis is strongly cutinized, may possess stomata and may give origin to plant hairs or trichomes. The periblem zone of stems gives rise to a hypodermis and an endodermis, between which are several layers of parenchyma cells, constituting the primary cortex. The hypodermis of stems usually contains chlorophyll or green coloring material. The walls of the primary cortical cells may become thickened through deposition of cellulose and assume collenchymatous forms. The endodermis of stems is not as well developed as that of the root. Fibro-vascular bundles are produced in the plerom zone; but these bundles are complete in form and consist of xylem, cambium and phloem elements even in the earlier stages. The pith parenchyma, which in roots is gradually replaced by woody tissues, persists in stems even throughout secondary structure. The tissues usually present in stems and rhizomes of primary structure, and the order in which they occur, beginning with the outermost, are as follows:

1. Epidermis,
2. Hypodermis,
3. Cortical parenchyma,
4. Endodermis,
5. Phloem elements,
6. Cambium,
7. Xylem elements,
8. Pith parenchyma.

By reference to Plate 56 it will be noted that each of these tissues presents structural characteristics whereby it may be distinguished. Presence of pri-

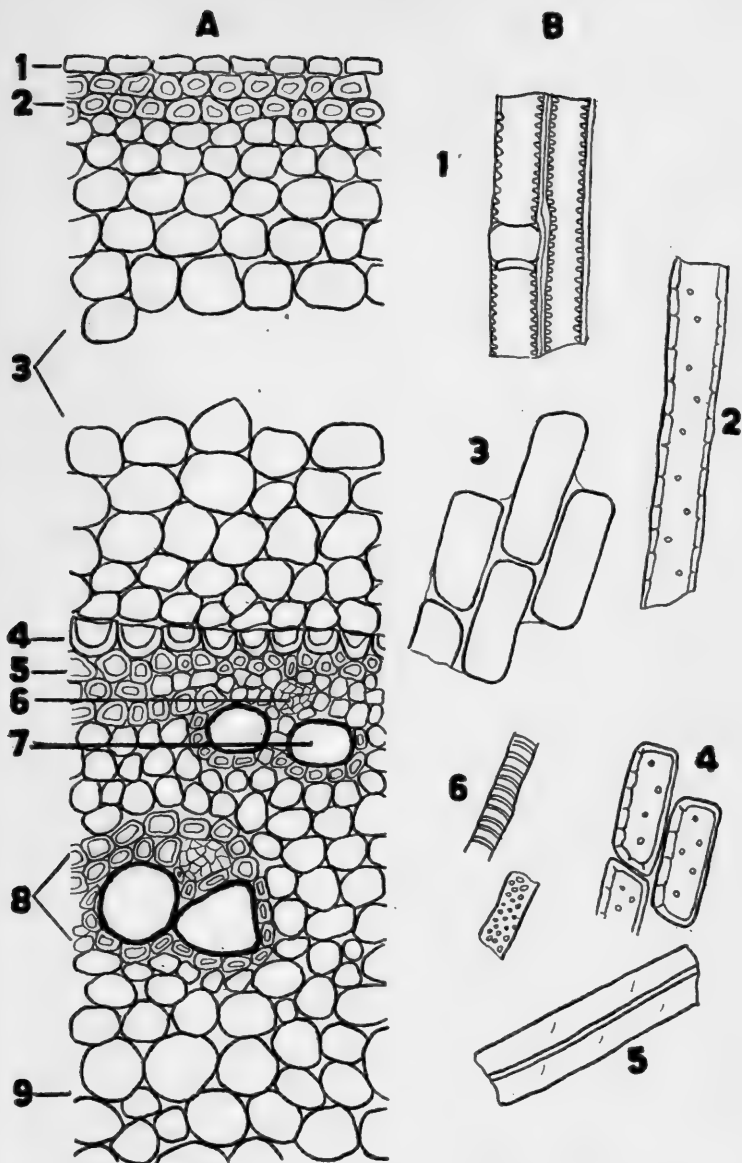

PLATE 56.—Primary Stem Structure (Monocotyledonous).

A. Transverse Section, Triticum Rhizome. 1. Epidermis. 2. Hypodermis. 3. Cortical parenchyma. 4. Endodermis. 5. Fibers, surrounding sieve and ducts. 6. Sieve. 7. Ducts. 8. Concentric fibrovascular bundle. 9. Pith parenchyma.  
 B. Powdered Triticum Rhizome. 1. Epidermis. 2. Hypodermis. 3. Parenchyma, longitudinal view. 4. Endodermis. 5. Fibers. 6. Vessels.

mary tissues is an indication that the material is from an herbaceous or a monocotyledonous stem. Herbaceous stems may be readily distinguished from those of mature monocotyledons by the character of the fibro-vascular bundles occurring in the specimen.

#### CHARACTERS OF THE PRIMARY STEM TISSUES

**Epidermis.**—The epidermis of herbaceous stems is a single layer of colorless transparent cells, the walls of which are impregnated with cutin. The individual cells, as seen upon transverse section, are more or less rectangular and fit together very closely. Upon surface view the cells appear rectangular, polygonal or irregular in form. The epidermal cells of many plants show wavy or undulating walls which fit into the corresponding walls of surrounding cells. Trichomes and stomata are often present and may be of assistance in identification. In powdered materials the epidermal cells are usually apparent on surface view and are frequently attached to the deeper tissues. In monocotyledonous stems of mature growth the epidermal tissues are so modified as to form a heavy covering layer. This, although differing from the cork layers of secondary stem structure, is very tough and resistant.

**Hypodermis.**—The hypodermal tissues of primary stems consist of several layers of thick-walled angled cells. In herbaceous stems, the hypodermal cells which contain chlorophyll are partly concerned in the production of starch. In monocotyledonous stems, the hypodermis persists and forms a covering tissue which reinforces the epidermis.



**Cortical Parenchyma.**—The primary cortex of stems is bounded on the outside by the hypodermis and on the inside by the endodermis. The cortical cells represent the original parenchymatic tissues of the periblem region. The primary cortex is several layers of cells in thickness, and various nutrients may be stored within these cells. The individual cells are usually thin-walled and irregularly circular in outline when seen in transverse section. In longitudinal view the cortical cells are either rectangular or polygonal. In certain herbaceous stems, the cortical cells become thick-walled through deposition of extra amounts of cellulose upon their walls, and are thus transformed into collenchyma. These groups of collenchymatic cells serve as supporting tissues which, because of the short life of such plants could not otherwise be produced in sufficient amounts. Stone cells are occasionally developed among the cortical cells.

**Endodermis.**—In stems, as well as in roots, this tissue separates the periblem tissues from those of the plerom. It is the innermost of the primary periblem tissues and its presence is an indication of primary stem structure. The endodermis usually consists of a single layer of cells and may not be as distinct as the corresponding tissue in roots. The individual cells are usually slightly colored and rectangular or polygonal in outline when viewed in transverse section. In certain roots the endodermal cell walls show uniform thickening on all sides; in other instances the side of the cell toward the cortex remains thin-walled.

In longitudinal section the endodermal cells resemble the corresponding cells of the root, being long and similar to fibers except that one wall is always thicker

than the other and that the end walls are blunt or square.

**Phloem, Cambium and Xylem Tissues.**—These tissues are developed as complete fibro-vascular bundles in the plerom zone and thus differ from the corresponding bundles in primary roots. In dicotyledonous stems the primary fibro-vascular bundles are of the open collateral type, or rarely the bi-collateral. In monocotyledonous stems the bundles are of the concentric, or more rarely, the closed collateral type. The cells entering into these different types of fibro-vascular bundles are similar in character to those described in the section dealing with secondary bundles in the root. (Chapter XIII.)

**Pith Parenchyma.**—This tissue represents the original parenchymatic tissue of the plerom zone. The individual cells possess slightly thickened and porous walls, are more or less spherical in form, and show exceedingly large intercellular spaces. The intercellular spaces become larger toward the center of the stem; therefore the central pith is a very loose structure, and may be lost or destroyed in the sectioning of herbaceous stems. In monocotyledonous stems the entire region within the endodermis is termed the *stele*, and consists of a groundwork of pith parenchyma cells in which are scattered isolated and irregularly arranged concentric or closed collateral bundles.

#### CELL CONTENTS OF PRIMARY STEMS

The cell contents of primary stems are stored in the parenchyma cells of the cortical and pith regions. Although these contents may include a variety of

substances, the most important from the histological standpoint are chlorophyll grains, starch, calcium oxalate crystals and volatile oil globules.

#### FUNCTIONS OF PRIMARY STEM TISSUES

The functions of the different structures present in primary stems may be summarized as follows:

Covering tissues . . . . .	{	Primary epidermis, Trichomes, Hypodermis.
Supporting tissues . . . . .	{	Bast fibers, Wood fibers, Stone cells, Collenchyma, Endodermis.
Absorbing tissues . . . . .		Stomata.
Assimilating and synthesis tissues . . . . .	{	Chlorophyll in hypoderm layer, Parenchyma, Glandular hairs.
Conducting tissues . . . . .	{	Sieve tubes, Ducts, Porous parenchyma.
Storage tissues . . . . .	{	Cortical parenchyma, Pith parenchyma.
Meristematic tissues . . . . .		Cambium.

#### SECONDARY STEM STRUCTURES

Secondary stem structures are present in mature dicotyledonous plants. They represent the permanent tissues of this class of plants and are found in woody stems. The changes occurring in the transition from

primary to secondary structure may be summarized in the following statements:

1. The epidermal and hypodermal tissues are replaced by elements originating from a phellogen or bark cambium, which develops within the primary cortex.
2. The endodermis is replaced by tissues developed from the cambium.
3. The original complete fibro-vascular bundles increase in size through additions of tissues by the cambium, and new bundles are formed in the broad primary medullary rays.
4. The cambium, originally in the form of arcs or segments between the xylem and phloem bundles, extends laterally and forms a complete ring or circle.
5. The pith is greatly reduced in size through extension of xylem elements and the formation of secondary bundles.

Owing to the thickness and complexity of the bark structures formed by the phellogen, it is more convenient to consider these separately from the woody tissues originating from the cambium. However, it must be kept in mind that both bark and wood are parts of the secondary stem.

### BARK STRUCTURE

From the histological standpoint, the bark of a secondary stem includes all structures external to the cambium. According to this statement it will be apparent that the phloem elements are considered with the bark tissues, rather than with the woody structures. True bark is only present in mature dicotyledonous plants, although monocotyledons possess a thickened epidermis which closely approximates bark in function and appearance.

As shown in Plates 57 and 58, the tissues usually present in barks, in the order of their arrangement, beginning with the outermost, are as follows:

1. Cork,
2. Phellogen and phelloderm,
3. Cortical parenchyma,
4. Stone cells,
5. Medullary rays,
6. Phloem elements.

It is convenient to divide the bark into outer, middle and inner layers or portions. In such a division, the outer bark includes the cork, phellogen and phelloderm structures. The middle bark is the region between the phelloderm and the outer ends of the medullary rays, and thus includes most of the cortical parenchyma and stone cells. The inner bark layer is traversed by the medullary rays and includes these structures, together with the phloem elements.

#### CHARACTER OF BARK STRUCTURES

**Cork.**—The periderm or corky layer of barks is usually very thick and consists chiefly of dead cells. The individual cells are generally dark colored and, in transverse section, appear as rectangular or polygonal cells with thick or thin walls. The walls of cork cells are strongly suberized; and the intercellular spaces are so small that, except for the openings caused by the formation of lenticels, the cork forms an impervious covering around the stem tissues.

**Phellogen and Phelloderm.**—In many barks these layers may be so reduced as almost to escape notice. The phellogen consists of one or more layers of color-

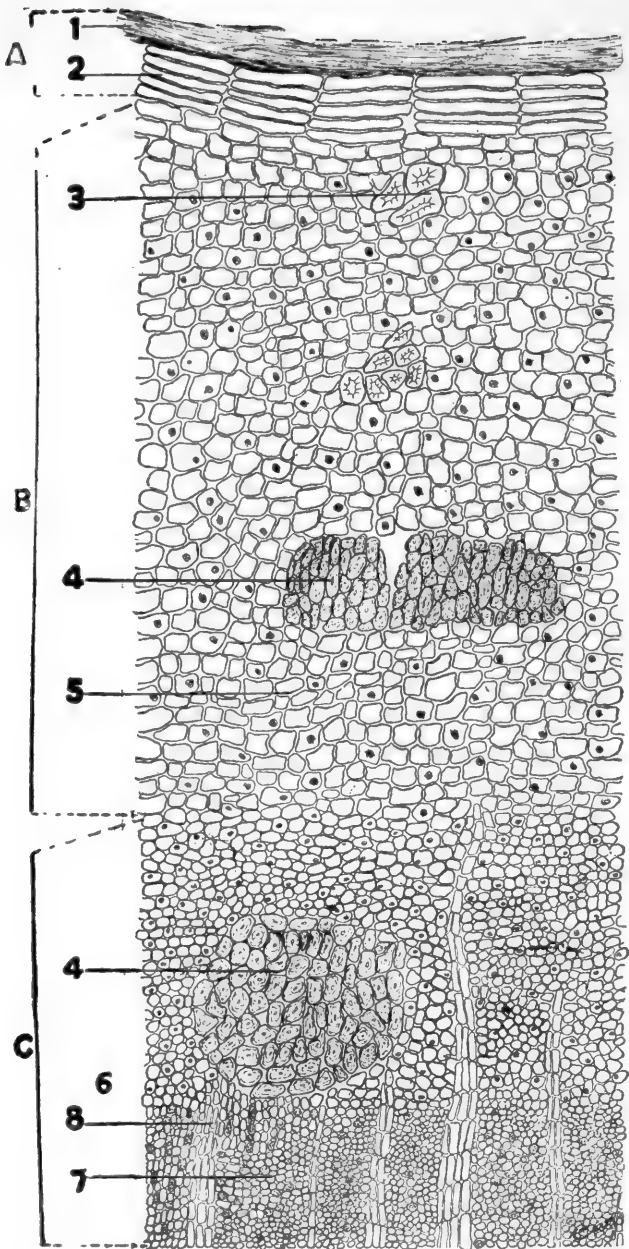
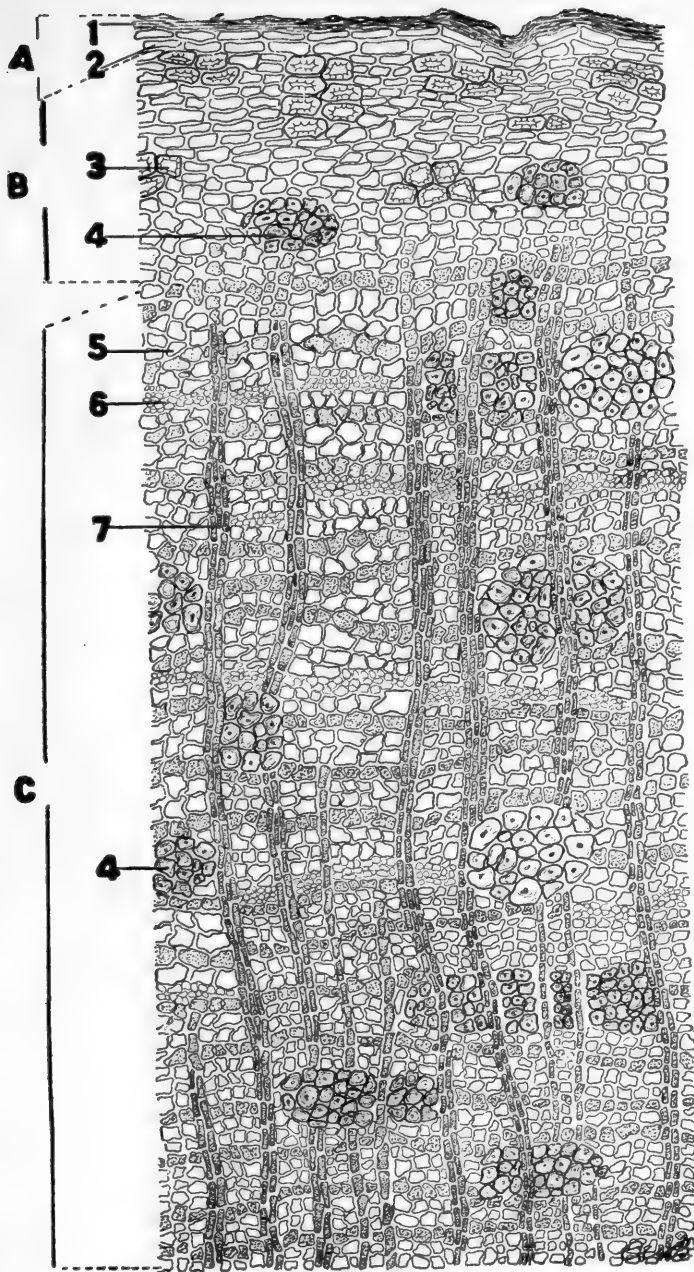

PLATE 57.—Bark Structure (Root).

Transverse Section, *Chionanthus* root bark. A. Outer bark. 1. Cork or periderm. 2. Phelloderm.  
 B. Middle bark. 3. Stone cells. 4. Fibers. 5. Bark parenchyma cells (starch and crystals have been partially removed in preparation of the specimen.)  
 C. Inner bark. 4. Fibers. 6. Parenchyma. 7. Sieve tissue. 8. Medullary ray.



**PLATE 58.—Bark Structure (Stem).**  
 Transverse Section, *Chionanthus* stem bark. **A.** Outer bark. 1. Periderm. 2. Pheloderm.  
**B.** Middle bark. 3. Stone cells. 4. Fibers.  
**C.** Inner bark. 5. Bark parenchyma. 6. Sieve tissue. 7. Medullary ray. 4. Fibers.

less, thin-walled, rectangular cells, immediately beneath the corky tissue. The walls of these cells are of cellulose and may be readily distinguished from the suberized cork cells by micro-chemical tests. The phel-

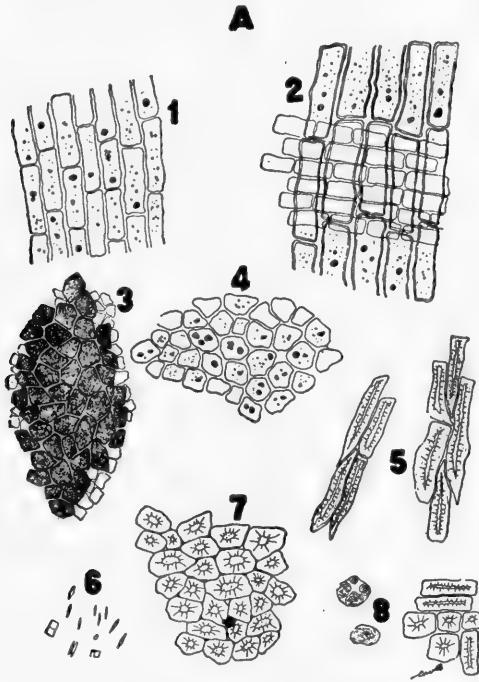

PLATE 59.—Bark Structure (Powdered material).

A. *Chionanthus*, root bark. 1. Bark parenchyma (longitudinal view), containing starch, crystals and resin masses. 2. Bark parenchyma crossed by medullary ray cells. 3. Cork tissue. 4. Bark parenchyma (transverse view). 5. Fibers. 6. Crystals. 7. Stone cells. 8. Resin masses.

loderm consists of one or more layers of rather thick-walled cells located beneath the phellogen. These cells are irregular in form and may be similar to collenchyma in appearance. The phellogen always pro-



duces more cork than phelloderm, and the latter tissue may occasionally be reduced to a single layer of cells. In powdered materials cork cells are usually apparent on surface view, and occur in thick masses

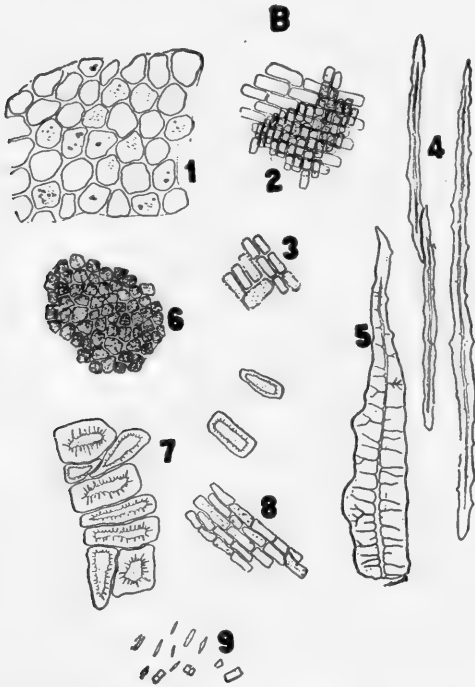

PLATE 59—Continued.

*B. Chionanthus*, stem bark. 1. Bark parenchyma (transverse view), containing starch, crystals and resin masses. 2. Bark parenchyma crossed by medullary ray cells. 3. Medullary ray cells. 4. Fibers. 5. Fibers showing branching pores. 6. Cork tissue. 7. Stone cells. 8. Bark parenchyma (longitudinal view). 9. Crystals.

of dark color in which definite cell structure is visible only with difficulty (Plate 59). The phellogen and phelloderm tissues are never apparent in powdered materials.

**Cortical Parenchyma.**—The parenchymatic tissues of the middle bark vary greatly both in quantity and in details of cell structure. Stone cells are rather frequently found among the cortical cells, and secretion cavities, when present, occur in this portion of the bark. The cortical cells contain starch, crystals or other cell contents. This tissue is present in powdered materials in the form of fragments consisting of several thin-walled angled or circular cells (Plate 59).

**Medullary Rays.**—The ray cells present in barks are usually smaller than those within the cambium. Seen in transverse section, the individual cells are thin-walled, square or oblong in form, and each ray is made up of from one to four rows of cells. In tangential sections the ends of the rays are apparent as oval or elliptical groups of polygonal cells. In radial sections one obtains a side view of the rays and they appear as broad bands of rectangular cells extending at right angles to the surrounding tissues. In powdered materials medullary rays are generally seen on radial view (Plate 59), and are usually in combination with parenchyma or other surrounding tissues. Occasionally, starch, crystals or other cell contents occur within the ray cells.

**Phloem Elements.**—The phloem elements in barks are usually located in the vicinity of the medullary ray cells. The bast fibers occur as groups of cells between the medullary rays or toward the outer ends of these. In transverse sections the individual fibers appear as small, thick-walled cells, readily distinguished from the surrounding elements, with the possible exception of stone cells. The lumen of these fiber

cells is often so reduced as to appear as a mere dot or mark in the center of the cell. Pores traversing the wall of the fiber are rarely apparent in sectional views. The sieve elements in barks are usually collapsed, and appear as very small, irregular, thin-walled cells adjacent to the bast fibers. In powdered materials the bast fibers are usually prominent, whereas sieve elements are rarely apparent. The fibers occur singly and in masses, frequently combined with parenchyma or ray tissues (Plate 59).

#### CELL CONTENTS

The cell contents in barks are stored in the cortical parenchyma, medullary rays and occasionally within stone cells. Resins and volatile oils are contained in special secretion cells or cavities. The stored materials include starch, crystals, tannins, resins, gums and volatile oils.

#### WOOD STRUCTURE

From a histological standpoint wood is the material remaining after removal of the bark. According to this statement, the wood includes all structures internal to the cambium. True wood is never present in the monocotyledonous stems which retain their primary structures through life. The structures usually present in woods, in the order of their arrangement, beginning with the outermost, are as follows:

1. Xylem elements,
2. Medullary rays,
3. Pith parenchyma.

## CHARACTER OF WOOD STRUCTURES

**Xylem Elements.**—The predominant structures in woody stems are wood fibers and ducts. A lignified type of parenchyma may be associated with these xylem elements. The wood fibers immediately adjacent to the cambium are living cells; but those nearer the center of the stem are to all intents lifeless. Each fiber is a typical prosenchymatic structure and, in longitudinal section, appears as a long, thick-walled cell tapering toward each end. The ends of fiber cells are usually pointed, and interlock or fit into corresponding ends of fibers below and above. Occasionally the ends of a fiber are branched. In transverse section, the fibers appear as angled cells with fairly thick walls and small central cavities (Plate 60). Pores penetrating the fiber wall may be apparent upon longitudinal view, but are rarely seen in transverse sections of a fiber. The ducts of woody stems are of the pitted or finely reticulate types. In transverse sections they appear as large, thick-walled cavities or cells, frequently with porous walls (Plate 60). The ducts usually occur in groups and are surrounded by wood fibers or woody parenchyma. It is in longitudinal section that the true nature of the duct is apparent, as its length and the character of its walls can only be seen in this view. Wood fibers and ducts extend parallel to each other and both are at right angles to the medullary rays. Woody parenchyma differs from fibrous tissue in that the cells are much shorter and thinner-walled (Plate 61). In form the woody parenchyma cells appear similar to true parenchyma; but the cellulose walls of the latter have

become partially lignified. In powdered woods (Plate 60) the fibers and ducts are always apparent on longitudinal view. Owing to the tenacity with which they adhere, wood fibers in powdered materials usually occur in masses. The cavities of the fibers occasionally contain crystals, coloring materials, volatile oils and rarely starch grains.

**Medullary Rays.**—These structures extend from the central region of the stem, through the xylem elements, to the cambium and thence to the bark tissues. They provide channels for the lateral transportation of nutrients, and communicate with both ducts and sieve tubes. The ray cells occur in groups which, viewed in different aspects, show great differences in appearance. In transverse sections the rays occur as bands composed of one to four rows of rather thin-walled, nearly rectangular cells (Plate 60). On this view the width of the entire ray and the width and length of the individual cells may be ascertained. In radial section the rays appear as broad bands composed of several rows of thin-walled, rectangular cells (Plate 61A). The height of the entire ray and the height and length of the ray cells are apparent on this view. In tangential sections the rays occur as oval or elliptical groups of circular or polygonal cells (Plate 61B). The width and height of the individual cells of the entire ray are apparent on this view. Medullary ray cells may or may not possess porous walls. The ray cells may contain starch, crystals or other cell contents. In powdered materials the ray cells (Plate 60) are apparent on radial and occasionally on transverse view. The masses of wood fibers frequently show attached ray cells, and in such

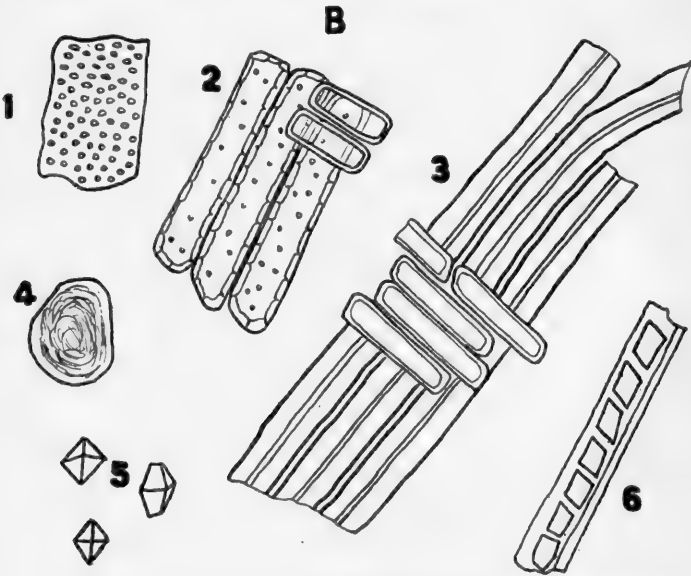
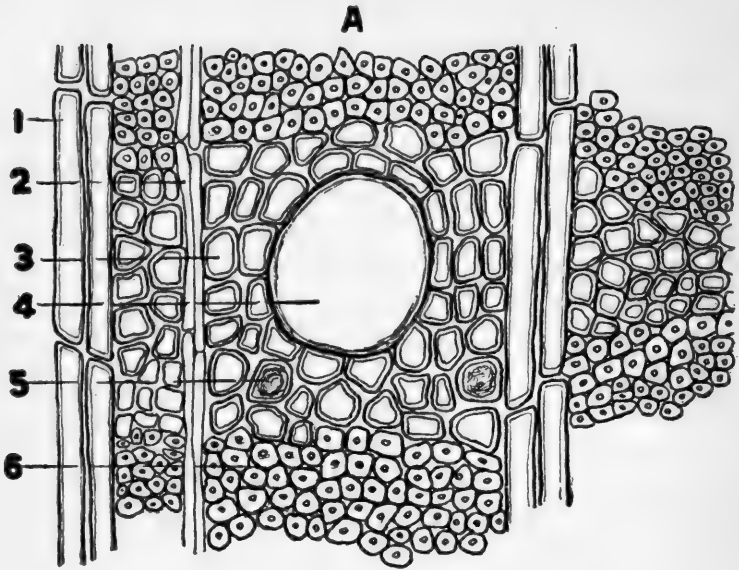

PLATE 60.—Wood Structure.

A. Transverse Section, Hematoxylon. 1. Medullary rays. 2. Resin passages. 3. Woody parenchyma. 4. Duct. 5. Resin mass in parenchyma cell. 6. Wood fibers.

B. Powdered Hematoxylon. 1. Vessel, pitted type. 2. Woody parenchyma with fragment of ray. 3. Fibers crossed by medullary ray cells. 4. Resin mass. 5. Crystals, prismatic type. 6. Crystal-bearing fiber.

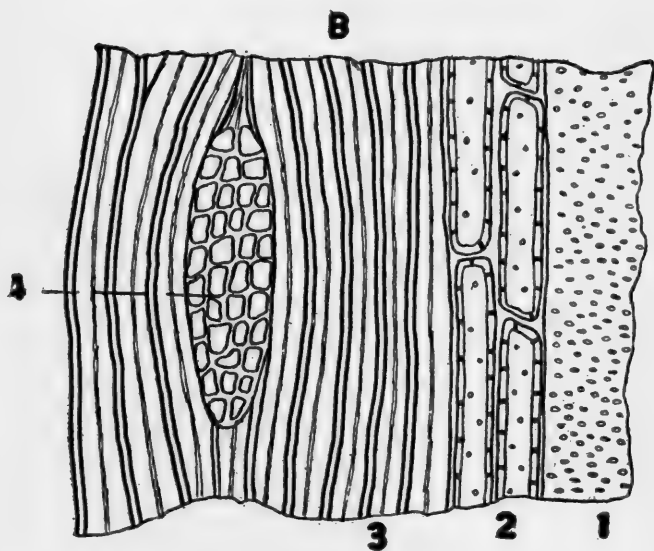
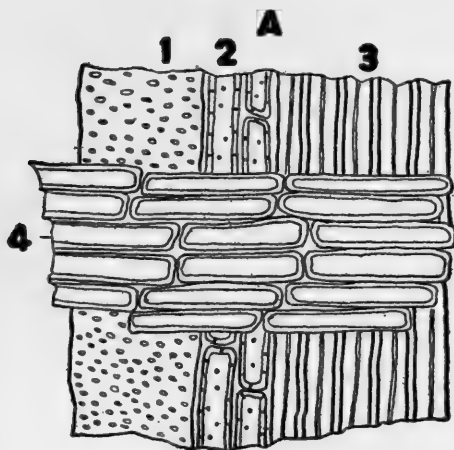

PLATE 61.—Wood Structure.

A. Radial Section, Hematoxylon. 1. Duct. 2. Woody parenchyma. 3. Fibers. 4. Medullary ray cells.

B. Tangential Section, Hematoxylon. 1. Duct. 2. Woody parenchyma. 3. Fibers. 4. Medullary ray cells.

fragments the ray cells are at right angles to the fibers.

**Pith Parenchyma.**—In mature woody stems this element is much reduced in quantity and may be entirely obscured. In other instances its position is indicated by a hollow cavity or space at the center of the stem. The individual cells are irregularly circular with thin and frequently porous walls. Owing to the small amount of pith parenchyma present in a mature woody stem, this element is rarely apparent in powdered materials.

#### CELL CONTENTS

The cell contents of woods are stored in the cavities of the fibers, in the ray cells and in the pith parenchyma cells. The stored materials include crystals, resins and volatile oils. Starch is rarely present in woods.

#### FUNCTIONS OF SECONDARY STEM TISSUES

The functions of the different structures present in secondary stems may be summarized as follows:

Covering tissues . . . . .	{	Cork or periderm, Phelloderm.
Supporting tissues . . . . .	{	Bast fibers, Wood fibers, Stone cells.
Absorbing tissues . . . . .		Lenticels.
Conducting tissues . . . . .	{	Sieve tubes, Ducts, Medullary rays.
Assimilating and synthesis tissues . . . . .		Secretion cells.
Storage tissues . . . . .		Bark parenchyma.
Meristematic tissues . . . . .	{	Phellogen, Cambium.



**RHIZOMES**

The characters and arrangements of tissues in underground stems or rhizomes correspond closely to those of overground stems. Monocotyledonous rhizomes retain the primary structures through life while those of the dicotyledonous class undergo the changes incidental to the formation of secondary tissues. Rhizomes showing primary structure are readily distinguished from roots by the presence of nodes or joints, and by the absence of root hairs. They are further distinguished from roots by the possession of complete fibro-vascular bundles even in the earlier stages of growth.

## CHAPTER XV

### LEAF STRUCTURE

THE leaves are lateral extensions of the stem, which have been expanded or otherwise modified in structure to function as manufacturing and assimilating organs. In their histological characters, leaves show many of the elements characteristic of primary stem structure; and, although these elements are more or less modified, a direct relationship can be traced between them and the cortex and central cylinder of the stem. Leaves manufacture the greater portion of the starch and may take part in the manufacture of other plant nutrients. These nutrient materials are transported through the leaf stem or petiole, and thence through the vascular tissues of the stem, to plant organs requiring nutrients or to storage tissues. The tissues present in leaves, in the order of their arrangement are as follows:

1. Upper epidermis,
2. Upper palisade,
3. Leaf parenchyma or mesophyll,
4. Fibro-vascular elements,
5. Lower palisade,
6. Lower epidermis.

#### CHARACTERS OF THE LEAF TISSUES

**Epidermis.**—The leaf epidermis usually consists of a single layer of strongly cutinized cells which function as a transparent, protective tissue. On

transverse section (Plates 62, 63), the epidermal membrane will be found to consist of rectangular or polygonal, thin-walled, colorless cells fitting tightly together with practically no intercellular spaces.

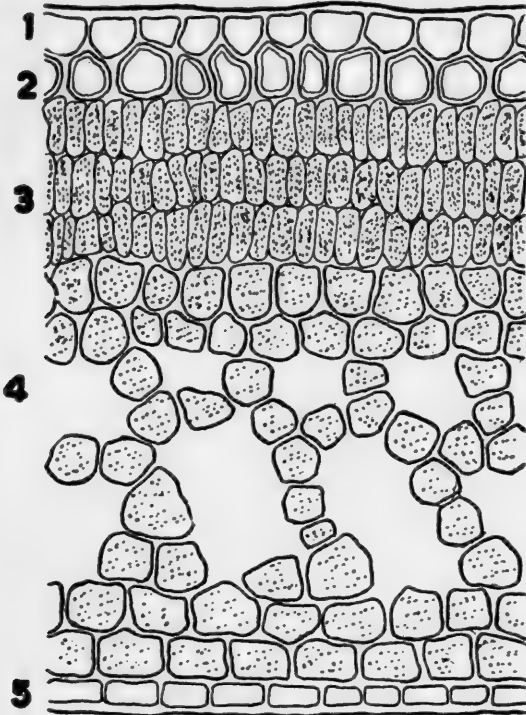

PLATE 62.—Leaf Structure.

Transverse Section, Oleander Leaf. 1. Upper epidermis. 2. Subepidermal or hypodermal layer. 3. Palisade cells. 4. Mesophyll or leaf parenchyma. 5. Lower epidermis.

The exposed wall of the epidermal cell may show more or less thickening, or may be further modified to form glandular or non-glandular trichomes. Occasionally a subepidermal or hypodermal layer of cells (Plate

63, No. 2) occurs immediately beneath the epidermis. These subepidermal cells are frequently present in

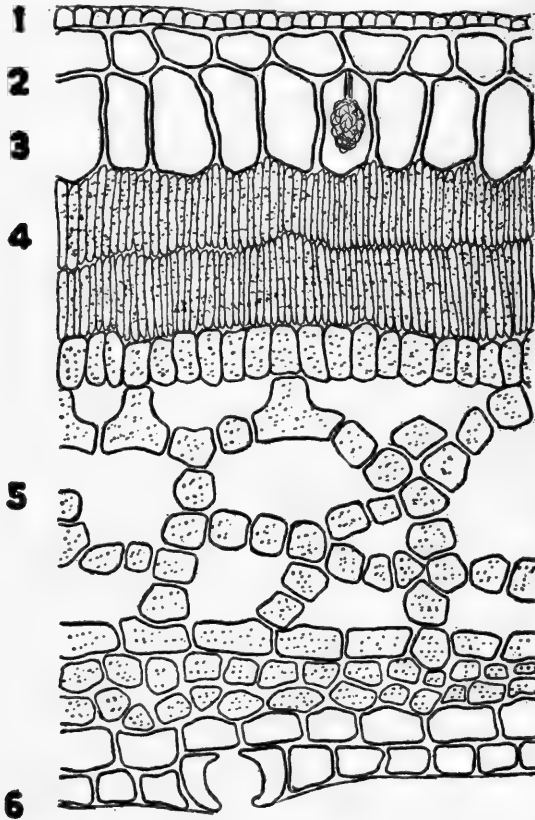

PLATE 63.—Leaf Structure.

Transverse Section, Ficus Leaf. 1. Upper epidermis. 2. Subepidermal or hypodermal layer. 3. Cystolith in subepidermal cell. 4. Palisade cells. 5. Mesophyll or leaf parenchyma. 6. Lower epidermis, showing stoma.

the leaves of tropical plants and may be of use in preventing excessive evaporation of water from the inner leaf tissues. Stomata or breathing pores are present

in the lower epidermis in the majority of leaves, and, in a few instances, also occur in the upper epidermis. On surface view the epidermal cells of different plants show definite characteristics as regards form of cells, character of their walls, location of stomata and occurrence of trichomes. On surface view the epidermal cells may be rectangular, polygonal or irregular in form (Plate 33). Their walls may be thin, irregularly thickened or beaded, and may show striations extending parallel with the border of the cell. The stomata may be located on the same level as the epidermal cells, or may be above or below the latter. Trichomes, both glandular and non-glandular, are outgrowths of the epidermal cells, and are exceedingly important in the identification of leaves in powdered condition. The more common forms of trichomes are described in connection with the covering tissues in Chapter VII. In powdered materials the epidermal cells are usually apparent on surface view, although they may be so adherent to the deeper tissues that details of cellular structure can only be seen with difficulty.

**Palisade Cells.**—These cells are located immediately below the epidermal or subepidermal tissues and are arranged in one or more layers (Plates 62, 63). Palisade layers may occur on both surfaces of the leaf or may be present only on the upper surface. *Unifacial leaves* are those possessing palisade tissues on both surfaces, while *bifacial leaves* possess only an upper palisade layer. Occasionally palisade tissues are lacking on both surfaces of the leaf. The individual palisade cells appear as narrow rectangles with the short side toward the epidermis. The walls are

thin, and the cavities are filled with chloroplasts. The palisade cells may be so grouped that several appear to be in contact with one of the leaf parenchyma cells. It is probable that the assimilation starch formed by the chloroplasts is removed through these leaf parenchyma cells. Oil or resin cells occasionally occur in the palisade layers. On surface view the palisade cells may be seen through the epidermis, and appear in small polygonal forms within the larger epidermal cells. In powdered materials the palisade cells may be seen in transverse section or on surface view. The green masses frequently apparent in powdered leaves consist of epidermal, palisade and perhaps leaf parenchyma cells, which hold together during powdering, and which are so thick that the cellular structure of each element in the mass is obscured.

**Leaf Parenchyma.**—The mesophyll or leaf parenchyma elements represent the original tissues of the leaf, or those which correspond to the tissues present in the plerom zone of the stem. The mesophyll consists of several layers of irregularly circular, thin-walled cells, loosely connected and showing large intercellular spaces (Plates 62, 63). This tissue fills in the space between the upper and lower palisade layers, or is the tissue between the epidermal layers when the palisade is lacking. The cells contain chloroplasts, and function partly as tissues for the manufacture of starch and partly as tissues for the transportation of the assimilation starch produced in the palisade cells. Stone cells of the branched type are occasionally present in the mesophyll layer. Crystals may occur in the leaf parenchyma cells. Starch grains in process of formation may be identified by special methods. In powdered materials the leaf

parenchyma is usually present in the form of green masses consisting either of mesophyll cells or consolidations of these with palisade and epidermis. Owing to the thickness of these fragments, details of cellular structure are apt to be obscured.

**Fibro-vascular Tissues.**—The fibro-vascular elements or veins of the leaf ramify in the mesophyll layer and correspond both in development and structure to the bundles of the stem. In dicotyledonous leaves the bundles are of the collateral type, while in monocotyledons the concentric and closed collateral arrangements may prevail. As in other parts of the plant, the fibro-vascular bundles function as supporting and conducting tissues. The work of transportation, or conduction of crude materials and manufactured nutrients to and from the leaf, requires a large and widespread vascular system; therefore the conducting elements of the bundles are more developed than are the supporting elements. The fibro-vascular tissue in the leaf stem, or petiole, is continued into the midvein in pinnately veined leaves, or into the primary veins in leaves of palmate venation. The midvein or primary veins branch repeatedly and form innumerable small veins, thereby connecting with every part of the leaf. As the fibrous elements of the bundles are often comparatively small, collenchymatic tissues may be developed in the vicinity of the larger veins, thus affording additional support. The fibro-vascular bundles are often surrounded by a sheath which corresponds to a rudimentary endodermis and which may function as a conducting element. The fibro-vascular bundles of the petiole and the sheaths surrounding them communicate either directly or indirectly, with bundles in the parent stem. In powdered

materials the fibers and vessels are usually clearly apparent. The fibers occur in groups, are thin-walled and comparatively few in number. The vessels occur either separately or in conjunction with the fiber masses. Spiral or annular vessels are the predominating types. In powdered leaves these elements are apparent on longitudinal view.

#### CELL CONTENTS

The cell contents of leaves are stored within the palisade cells, mesophyll parenchyma, secretion cells and glandular hairs, and occasionally in the fibers. The most important stored material is chlorophyll, a protoplasmic cell content. The nonprotoplasmic contents include volatile oils, calcium oxalate crystals and calcium carbonate deposits or cystoliths.

#### FUNCTIONS OF LEAF TISSUES

The functions of the different structures present in leaves may be tabulated as follows:

Covering tissues . . . . .	{ Epidermis, Trichomes.
Supporting tissues . . . . .	{ Bast fibers (traces), Wood fibers (traces), Collenchyma, Stone cells (rarely).
Conducting tissues . . . . .	{ Sieve tubes, Ducts, Vessel sheaths, Mesophyll.
Absorbing tissues . . . . .	Stomata.
Assimilating and synthesis tissues . . . . .	{ Palisade, Mesophyll, Secretion cells, Glandular hairs.
Storage tissues . . . . .	{ Secretion cells, Glandular hairs.



## CHAPTER XVI

### FLOWER STRUCTURE

THE floral organs are developed from leaves, which, by various processes of modification, have been fitted to perform the functions of producing seeds. In many instances the relationship between the floral part and the leaf, as regards both characters and structural peculiarities, is clearly evident. The sepals, or parts of the calyx, usually bear a close resemblance to leaves, in color and form. In other floral organs the modifications so obscure this relationship that the true nature of the organ in question can only be ascertained by considering its *ontogeny*, or the changes occurring during the period of its development. The stamens bear little resemblance to foliage leaves; and it is only by a study of the changes which occur during their development that the structural relationship has been established. Each organ of the flower possesses structural characters peculiar to itself, and more or less common to corresponding parts in other flowers. However, the deviations from typical characters are so frequent in the floral organs, that it is impossible to give descriptions which will apply in all instances. The structures present in a typical complete flower, beginning with those of the outermost circle, are as follows:

1. Bract tissues,
2. Calyx tissues,
3. Corolla tissues,
4. Stamen tissues,
5. Pistil tissues,
6. Stem tissues.

#### CHARACTERS OF THE FLORAL TISSUES

**Bract Tissues.**—These structures, which are known collectively as the *epicalyx*, are not a part of the flower as they do not originate from the torus, or structure which gives rise to the floral organs. The bracts originate from the stem and are foliage leaves which, because of modification in form and contiguity of position, simulate floral parts. Their histological characters are similar to those of leaves, and they show epidermal tissues with stomata and perhaps trichomes, palisade layers, mesophyll and the fibro-vascular structures of leaves.

**Calyx Tissues.**—The sepals, or calyx divisions, are classed as floral organs because they originate from the torus. In most flowers the sepals are green and leaf-like; but in those flowers in which the corolla is wanting (monochlamydeous), the calyx may simulate a corolla in appearance and structure. The histological elements present in sepals include epidermal tissues, mesophyll and simple forms of fibro-vascular bundles. The epidermis (Plate 64) bears stomata on the outer or free surface and may also show trichomes. The green tissues consist of loosely arranged mesophyll or leaf parenchyma cells containing chlorophyll. The palisade layers are usually lacking. The fibro-vascular tissues are not as widespread nor as complex as those of leaves; and the fibrous elements are much reduced in amount.

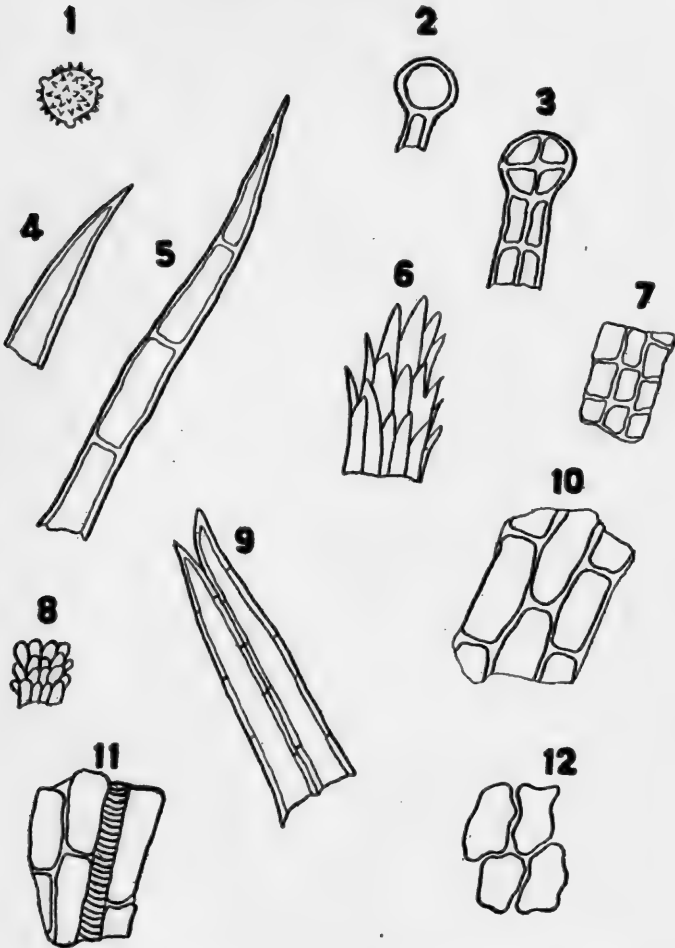

PLATE 64.—Flower Structure.

Powdered Arnica Flowers. 1. Pollen grain. 2. Glandular trichome (unicellular). 3. Glandular trichome (multicellular). 4. Nonglandular trichome (unicellular). 5. Nonglandular trichome (multicellular). 6. Nonglandular trichome (multiseriate). 7. Stamen tissue. 8. Stigma tissue, showing papillæ. 9. Nonglandular trichome (bicellular). 10. Petal tissue. 11. Petal tissue, showing spiral vessel. 12. Calyx tissue.

**Corolla Tissues.**—The *petals* or corolla divisions constitute the circle of floral leaves next inside the calyx. If there be but one circle of floral leaves in the flower it is classed as calyx, no matter what its color or form. The corolla in most flowers is white or variously colored, the color being due to pigments contained in the parenchyma cells or dissolved in the liquids within and around the cells. The histological elements present in petals include epidermal tissues, parenchyma and traces of fibro-vascular bundles. The epidermis (Plate 64), is rather similar to that of the leaf, rarely shows stomata and often possesses papillæ. Striated and beaded forms of cell walls occur in this tissue, and glandular hairs are occasionally present. The parenchyma corresponds to the mesophyll of leaves, but contains pigments or colored cell liquids other than chlorophyll. The fibro-vascular tissues are even more rudimentary than those of the calyx, and consist of annular, spiral or reticulate vessels almost lacking in fibrous supporting elements.

**Stamen Tissues.**—The *stamens* collectively constitute the *androecium* or male reproductive structures of the flower. Each stamen consists of anther, connective and filament. The anther consists of two parts attached to each other, and to the stem-like structure or filament, by the connective. The histological elements present in stamens include epidermal tissues, parenchyma, fibro-vascular tissues and pollen grains. The epidermis covering the anther and filament is similar to that of the corolla. Parenchyma is present in the filament and connective, but is wanting or much reduced in the anther. The parenchyma cells (Plate 64), are small and are disposed around the simple,

central fibro-vascular bundle of each filament. The fibro-vascular elements consist of spiral or annular vessels with practically no fibrous tissue. The *pollen* (Plate 64) is the most important histological element of the stamen tissues, for in many instances the grains present characters of great importance to the analyst. Pollen grains, although uniform in a given plant, show great variation in size, form and surface markings. They may be spherical, ellipsoidal, triangulate or polygonal in form. Pores, grooves and elevations may be apparent on the outer surface. In many instances the outer surface shows numerous spiny projections which are probably for the purpose of firmly fixing the grain upon the stigmatic surface. Grains possessing these spines or projections are termed *spinose* in contradistinction to the smooth-surfaced grains.

**Pistil Tissues.**—The *pistils* collectively constitute the *gynæcium* or female reproductive structures in the flower. Each pistil consists of stigma, style and ovary. The stigma is the uppermost portion of the pistil and is connected with the ovary by the style. The histological elements present in the pistil include epidermal tissues, parenchyma, fibro-vascular elements and ovules. The epidermal tissues of the stigma are of two distinct varieties. The upper surface of the stigma or the surface designed as a resting place for the pollen, is usually roughened either by papillæ (Plate 64), or by a peculiar palisade formation of the epidermal cells. In other instances the stigmatic surface is smooth, but secretes viscid liquids which hold the pollen when the latter comes into contact with it. The style and ovary are covered with a thin epidermal

tissue which may show stomata and trichomes. The parenchymatic tissues of stigma, style and ovary consist of loosely connected cells showing large intercellular spaces. These parenchyma cells usually contain chloroplasts. The fibro-vascular tissues are of great importance in the style and ovary, as in the former organ they provide a channel for the descent of the pollen tube, and in the latter they conduct nutrients to the developing embryo. The ovules are covered with a thin but resistant epidermis, within which are parenchyma cells containing large amounts of nutrient material and the developing embryo.

**Stem Tissues.**—The stem tissues of the flower are in every respect similar to other plant stems and exhibit the elements noted in the section on Primary Stems (Chapter XIV). Stone cells are of frequent occurrence in flower stems, and their presence often affords a means of detecting excess stems in flower powders.

#### CELL CONTENTS

The cell contents of flowers are stored within the parenchyma cells of the different floral organs. The protoplasmic cell contents include chlorophyll and various other pigments. The non-protoplasmic contents include calcium oxalate crystals and the volatile oils secreted by glandular hairs. Starch is rarely present.

#### FUNCTIONS OF FLOWER TISSUES

The functions of the different structures present in flowers may be summarized as follows:

Covering tissues . . . . .	{	Epidermis, Trichomes.
Supporting tissues . . . . .	{	Fibers, Stone cells (from stems),
Absorbing tissues . . . . .		Stomata.
Conducting tissues . . . . .		Ducts.
Assimilating and secretory tissues . . . . .	{	Palisade of calyx, Glandular hairs, Secretion cells.
Reproducing tissues . . . . .	{	Inner epidermal layers of anther and ovary.

## CHAPTER XVII

### FRUIT STRUCTURE

A **FRUIT** is a ripened pistil containing the fertilized ovules or seeds, together with modified structures derived from almost any part of the flower with the possible exceptions of stamens and stigma. The term *pericarp*, as applied to fruits, includes all structures excepting the seeds. The pericarp is divisible into three layers, an *exocarp* (*epicarp*) or outer layer, a *mesocarp* or middle layer and an *endocarp* or inner layer. In closely related classes of fruits, these layers present similar structural characters; but in different classes of fruits the structural variations are very great. It is impossible to cover all these variations by general statements; therefore two important types of fruits are considered in the following notes. It must be borne in mind that even fruits of these classes will show more or less variation from the structures described.

#### CREMOCARPS

Fruits of the cremocarp class are characterized by the fact that they separate at maturity into one-seeded parts. The fruits of the Umbelliferae, which include anise, fennel, caraway, coriander and angelica, are termed cremocarps. In drug commerce these fruits are known as seeds; but this is incorrect, as



upon close examination they will be found to consist of a pericarp within which is the seed.

**Exocarp Tissues.**—As seen in transverse section, the exocarp in this type of fruits consists of a single layer of colored, rather thick-walled, irregularly elongated cells (Plate 65). These cells may possess striated walls, rarely show stomata, and may give rise to papillæ or unicellular trichomes. On surface view the exocarp appears to be composed of colored polygonal or irregular cells, and is usually adherent to the tissues of the mesocarp. Surface views are usually obtained in powdered materials although an occasional transverse fragment may be apparent.

**Mesocarp Tissues.**—The mesocarp layer consists of rather thick-walled parenchyma cells, oil ducts and fibro-vascular elements (Plate 65). This layer varies in thickness, owing to the presence of ribs or elevations which are apparent on the outer surface of the fruit. The number of ribs is fairly constant for each species of umbelliferous fruits. The oil ducts are called *vittae* and are continuous structures, although they may show markings indicating the junctions of the cells composing them. They extend through the entire length of the fruit. The number of *vittae* is constant for a given fruit, and each duct is surrounded by a layer of thickened parenchyma cells. The fibro-vascular bundles consist of small numbers of short, thick-walled fibers in conjunction with annular or spiral vessels. In powdered materials the parenchyma appears as a mass of thick, white-walled cells, either separate from or combined with fragments of the *vittae*. The *vittae* are always seen on longitudinal or surface view, and appear as broad,

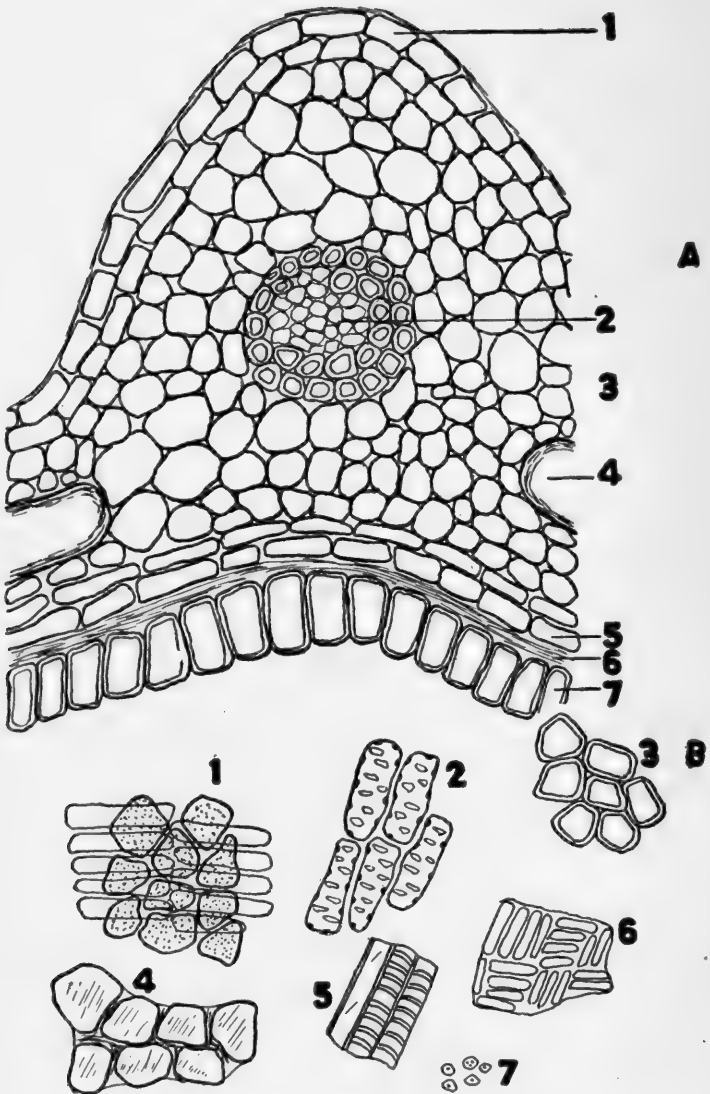

PLATE 65.—Fruit Structure.

A. Transverse Section, Fennel Fruit. 1. Epicarp or epidermis. 2. Fibrovascular bundle. 3. Mesocarp parenchyma. 4. Secretion cavity or vitta. 5. Endocarp layers. 6. Seed coat layers. 7. Endosperm of seed parenchyma.

B. Powdered Fennel Fruit. 1. Epicarp adherent to dark cells lining vittae. 2. Porous parenchyma of mesocarp. 3. Endosperm cells. 4. Parenchyma of mesocarp. 5. Fibrovascular elements. 6. Endocarp cells. 7. Aleurone grains from seed parenchyma.

colored bands traversing the parenchyma masses. The fibro-vascular elements are comparatively few, the fibers and vessels being apparent on longitudinal view.

**Endocarp Tissues.**—The endocarp usually consists of a single layer, or, at most, two layers, of irregularly rectangular cells (Plate 65). In powdered materials the endocarp cells are usually apparent on surface view as masses of thick-walled, long, rectangular cells, either separated from or attached to the mesocarp tissues. In certain fruits of this class the endocarp cells are arranged in groups, the cells of each group extending in different directions from those of the surrounding groups, in a manner similar to the strips in parquet flooring.

#### DRUPACEOUS FRUITS

The drupaceous fruits are indehiscent, and their seeds are separated from the mesocarp layer by a hard endocarp. Certain fruits of this class possess fleshy mesocarps, while in others the mesocarp layer is dry and compact in texture. The structures described in the following notes on the pepper fruit are more or less common to the non-fleshy drupaceous fruits.

#### PEPPER

**Exocarp Tissue.**—This tissue consists of a single layer of rectangular or polygonal cells. The individual cells are dark-colored and rather thick-walled (Plate 66). In powdered pepper the cells of this layer are seen on surface view and appear as masses of brownish or black polygonal cells, usually consolidated with the outer stone cells of the mesocarp.

**Mesocarp Tissue.**—The different parts of this layer show considerable differentiation. Immediately beneath the exocarp is a layer or two of thick-walled, rectangular, porous, yellow or brownish stone cells with their narrow sides toward the thin exocarp which they reinforce. Irregular, angled, thin-walled parenchyma cells form the greater part of the mesocarp tissues; but many of these become transformed into secretion cells and contain volatile oil. The parenchyma cells near the endocarp are very small and are divided into two zones by an irregular layer of large oil-secretion cells. The fibro-vascular bundles, consisting of spiral vessels and small amounts of fibrous tissue, are scattered through the mesocarp layer. In powdered materials the cells of this layer are apparent on surface view. The stone cells are usually consolidated with fragments of the epidermis, and are irregular in form with thick, porous walls (Plate 67). As the parenchyma is thin-walled, it is usually broken in powdering. The compound starch masses (Plate 67), contained in these cells, remain more or less unbroken. Several starch masses may adhere, thus preserving the form and often the walls of the parenchyma cells. The oil cells are present as circular or polygonal thin-walled elements, each cell containing one or more highly refractive oil globules. The fibro-vascular tissues are apparent in longitudinal view, and consist of spiral vessels, usually in combination with rather thick-walled, porous fibers.

**Endocarp Tissues.**—The endocarp consists of a single layer of stone cells. The individual cells are rectangular, porous, and thickened on three sides. In powdered pepper these stone cells may be apparent

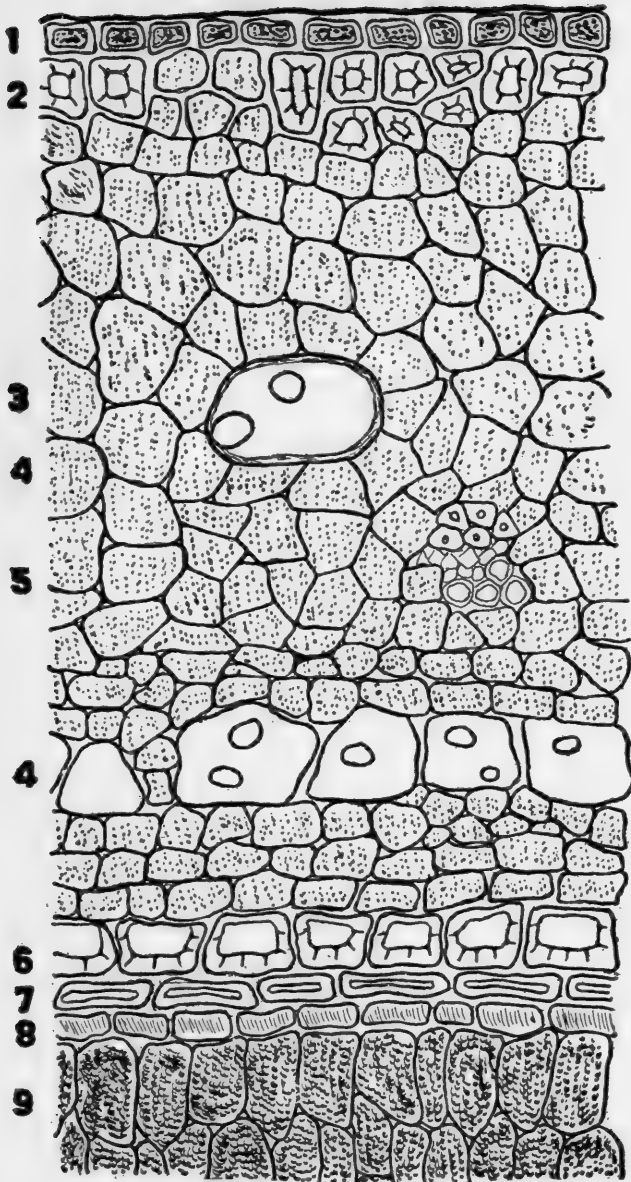

PLATE 66.—Fruit Structure.

Transverse Section, Black Pepper. 1. Epicarp layer. 2. Stone cells of hypodermal or outer mesocarp layer. 3. Mesocarp parenchyma. 4. Secretion cavity. 5. Fibrovascular bundle. 6. Stone cells of endocarp or inner mesocarp layer. 7. Seed coat tissue, testa and tegmen. 8. Aleurone layer, surrounding the endosperm. 9. Endosperm or seed parenchyma.

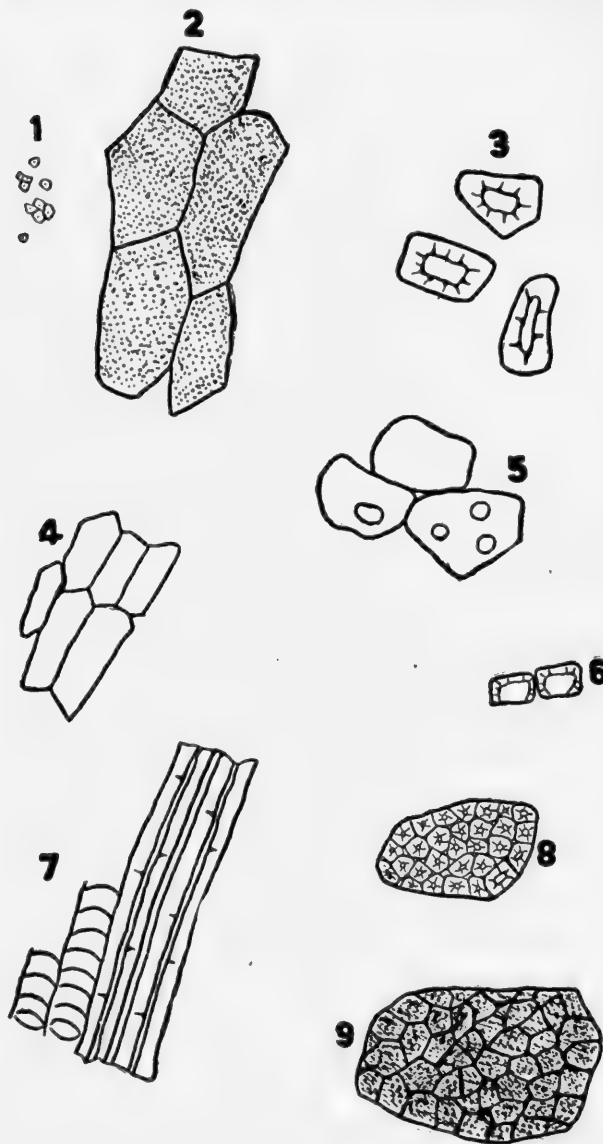

PLATE 67.—Fruit Structure.

Powdered Black Pepper. 1. Starch, single grains. 2. Starch, compound grains. 3. Stone cells from outer mesocarp layers. 4. Seed coat tissue. 5. Mesocarp parenchyma containing oil globules. 6. Endocarp stone cells, sectional view. 7. Fibrovascular elements. 8. Endocarp stone cells, surface view. 9. Epicarp tissue.

in surface and transverse views. They usually occur as masses of small, angled, porous, thick-walled cells of dark color. On transverse view the thickening on three sides of the cell is apparent.

#### CELL CONTENTS OF FRUITS

The stored materials in fruits are usually contained within the mesocarp parenchyma cells. Owing to the great diversity in the characters of the different fruits, the cell contents are exceedingly varied and may include starch, sugars, volatile oils, alkaloids, glucosides and calcium oxalate crystals. The various pigments in fruits are classified as protoplasmic cell contents.

#### FUNCTIONS OF FRUIT TISSUES

The functions of the different structures present in fruits may be summarized as follows:

Covering tissues.....	{	Epidermis, Trichomes.
Supporting tissues.....	{	Stone cells, Bast fibers (traces), Wood fibers (traces), Collenchyma.
Absorbing tissues.....		Stomata (rare).
Conducting tissues.....		Ducts.
Assimilating and secreting tissues.....	{	Secretion cells, Glandular hairs.
Storage tissues.....		Parenchyma.

## CHAPTER XVIII

### SEED STRUCTURE

A SEED is a fertilized ovule and consists of coats, nourishing materials and an embryo. The coats are usually two in number, the *testa* or outer and the *tegmen* or inner coat, although a third coat or *aril* may be developed outside the *testa*. The coats may be merged in such a manner that their structure is difficult to discern. The embryo, or miniature plant, contains or is surrounded by a store of nourishment termed *endosperm*. The term *perisperm* is applied to portions of the nucellus of the ovule, when these persist in the seed. A certain amount of nourishing material may be stored in the nucellus. The tissues present in a seed, in the order of their position, beginning with the outermost, are as follows:

1. Epidermis or *testa*,
2. Inner epidermis or *tegmen*,
3. Endosperm tissues,
4. Embryo tissues.

It is difficult to give general descriptions of the cellular elements of seeds for, like fruits, they vary so greatly that it is impossible to select any one seed as a type. In the following notes, two types of seeds will be described. In the first type, of which wheat is selected as a representative, the nourishment, or endosperm, is stored outside of the embryo. In the



second type, of which mustard seed is a fair example, the nourishing material or endosperm is stored within the embryo.

#### WHEAT

The structural elements present in wheat are found with but slight variations in most of the grains. The wheat grain is a fruit, possessing exocarp, mesocarp and endocarp layers. The seed is in close proximity to the endocarp, and some of the tissues of the latter layer may be present in wheat flour.

**Tissues of the Testa and Tegmen.**—These elements are usually closely adherent and each consists of a single layer of cells (Plate 68). On transverse view, the individual elements appear as small, elongated, rectangular, thick-walled cells in close contact with a thin layer of tissue which rarely shows definite cell structure, and which represents the tegmen. In powdered materials these tissues are seen on surface view and consist of long, thin-walled, slightly colored angled cells of irregular shape. The testa and tegmen cells usually extend at right angles to each other as may be plainly seen in surface preparations.

**Endosperm Tissues.**—Remnants of a perisperm layer usually occur in the seeds of grains; but the tissues are so reduced that they appear as a thin membrane between the tegmen and the endosperm. The cellular structure of this perisperm can only be distinguished in surface preparations. In transverse sections the outermost layer of the endosperm will be apparent as regularly arranged, square or rectangular, thick-walled cells (Plate 68), containing darker contents than the cells more deeply located. These

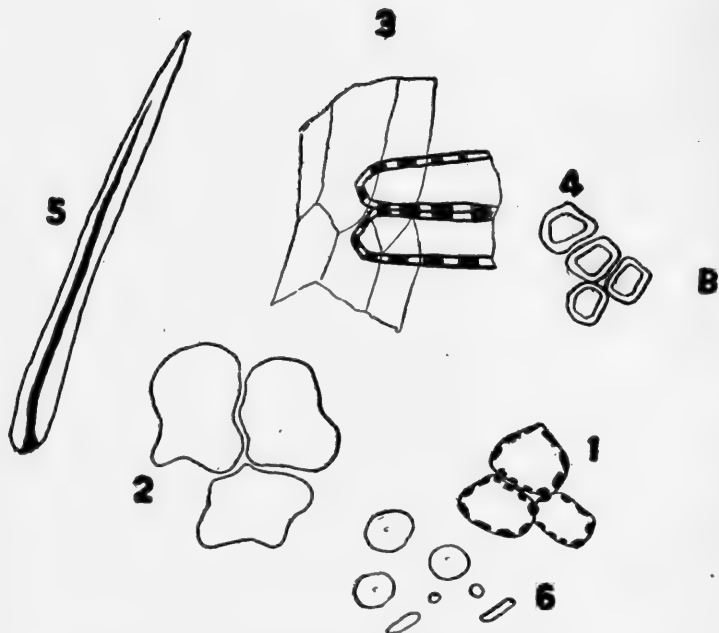
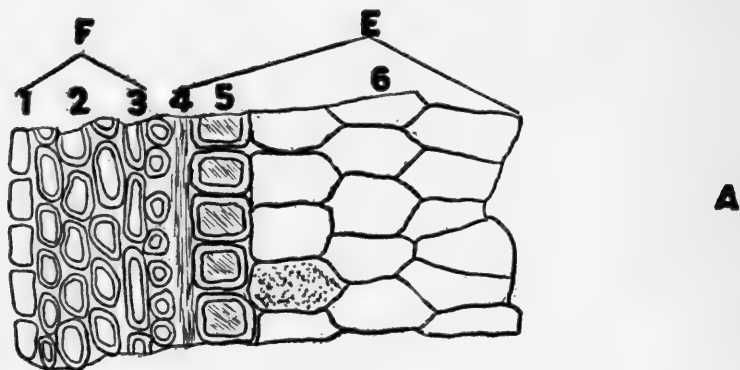

PLATE 68.—Seed Structure.

*A.* Transverse Section, Wheat. *F.* Pericarp or fruit layers. 1. Epicarp. 2. Mesocarp. 3. Endocarp. *E.* Seed Tissues. 4. Seed coats consolidated with perisperm layer. 4. Endosperm, aleurone layer. 6. Endosperm, parenchyma containing starch.

*B.* Powdered Wheat. 1. Epicarp tissue. 2. Perisperm tissue. 3. Seed coat tissue. 4. Aleurone cells of the endosperm. 5. Unicellular trichome from epicarp. 6. Starch.

cells contain aleurone and are known as *aleurone* or *gluten* cells. The remaining endosperm tissues consist of large, thin-walled parenchyma cells filled with starch. In powdered materials the perisperm layer appears as a thin membrane composed of large, thin, wavy-walled cells. The aleurone cells are apparent in sectional and surface views. On sectional view they are square and usually occur in strips of five to ten adhering cells (Plate 68). On surface view they appear as circular or polygonal forms, with thick white walls and gray contents. The endosperm parenchyma is apparent as irregularly polygonal and circular thin-walled cells, filled with starch and seldom present in unbroken condition.

**Embryo Tissues.**—The embryo, or germ, of wheat is a small body at one end of the grain. It consists of a large cotyledon, or seed leaf, which encircles the other parts of the embryo. The embryo is composed of small parenchymatic cells with rudiments of fibro-vascular tissue. In the milling of flour the embryo is removed from the grain, as, owing to the fat contained, it imparts an unpleasant taste to the product.

#### BLACK MUSTARD

The structural elements present in this seed are found with greater or less variation in many other seeds.

**Tissues of the Testa and Tegmen.**—These tissues are arranged in four layers in the following order, epidermal mucilage cells, subepidermal cells, stone cells and pigment cells. Seen in sectional view (Plate 69), the outer epidermal cells appear as long rectangu-

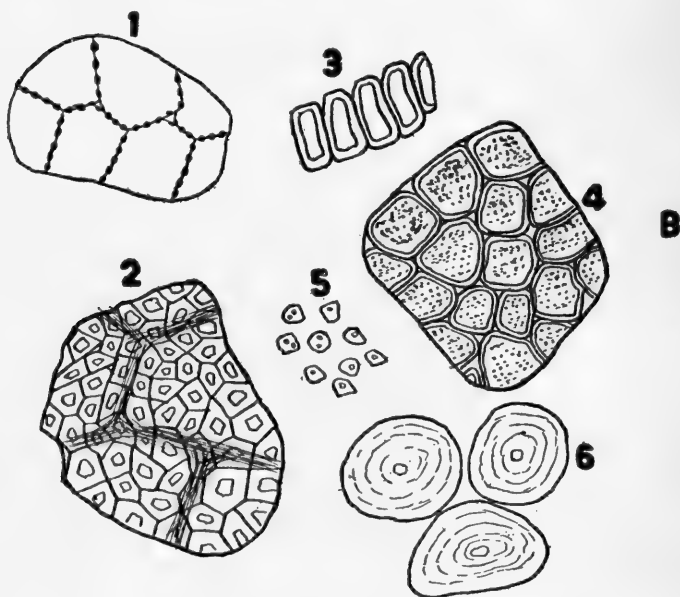
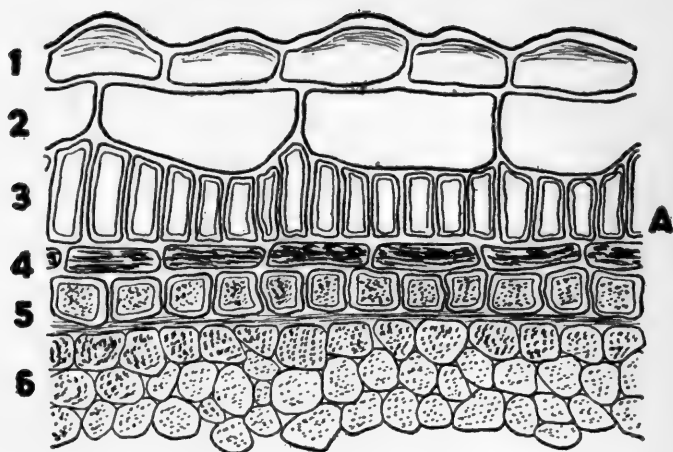

PLATE 69.—Seed Structure.

A. Transverse Section, Black Mustard Seed. 1. Epidermal layer of testa. 2. Subepidermal layer of testa. 3. Palisade layer of testa. 4. Pigment layer or tegmen. 5. Endosperm. 6. Parenchyma of cotyledon containing aleurone.

B. Powdered Black Mustard Seed. 1. Epidermal cells. 2. Subepidermal and Palisade layers consolidated. 3. Palisade cells. 4. Parenchyma of cotyledon. 5. Aleurone grains. 6. Mucilage cells.

lar forms with slightly thickened walls. The sub-epidermal cells are large, thin-walled and very irregular in form. The stone cells are small and of varying lengths, arranged so that the short side of the cell is toward the epidermal layers. These stone cells are termed the palisade layer. The pigment cells are long and narrow, and are so arranged that their long sides are toward the palisade layer. In powdered mustard these tissues are usually seen on surface view, although small fragments of seed coat tissue may be apparent on sectional view. The epidermis (Plate 69) is brown and composed of large, polygonal cells with beaded walls. The subepidermal tissue is usually adherent to the palisade layer and is visible as large polygonal cells of indistinct form in fragments of the palisade tissue. The palisade tissue is composed of small, thick-walled, angled stone cells. The pigment layer consists of large, angled cells of dark color, usually adherent to the palisade tissue.

**Endosperm Tissues.**—The endosperm of mustard is contained within the cotyledons or miniature leaves of the embryo. The cotyledons are covered by a thin epidermal layer of cutinized cells. The endosperm cells (Plate 69), are angled or irregularly circular in form with slightly thickened white walls. In powdered mustard the endosperm cells usually appear in masses composed of irregularly circular, white-walled cells containing a grayish aleurone.

**Embryo Tissues.**—The cotyledons of the mustard embryo may show distinct signs of tissue differentiation. A rudimentary leaf epidermis and traces of palisade cells are present; and the fibro-vascular elements are represented in the stem portion of the embryo.

## CELL CONTENTS OF SEEDS

The cell contents of seeds are contained within the parenchyma of the endosperm. These contents are exceedingly varied and may include starch, aleurone, fixed oils, volatile oils, alkaloids and glucosides. Aleurone usually occurs in seeds containing fixed oil; but starch is rarely, if ever, present in seeds containing these substances.

## FUNCTIONS OF SEED TISSUES

The functions of the different structures present in seeds may be summarized as follows:

Covering tissues . . . . .	{	Epidermis, Stone cells.
Supporting tissues . . . . .	{	Stone cells, Fibers (rarely).
Storage tissues . . . . .	{	Parenchyma, Collenchyma.

## CHAPTER XIX

### MICROSCOPE ACCESSORIES

#### MECHANICAL STAGE

THE device known as the mechanical stage is essential in work requiring the systematic examination of several fields or all parts of the specimen. It is used in the quantitative estimation of the different types of cells in blood samples; in the examination of urinary sediments, and in bacterial, mold and spore counts. The more complicated types of microscopes are provided with mechanical stages which are permanently attached to the instrument. This construction presents the advantages of rigidity and fixed position. However, these fixed mechanical stages are often inconvenient and are liable to corrosion if temporary mounts are frequently used. To overcome these faults many manufacturers supply an extra, or plain, stage, which is interchangeable and can be substituted for the fixed mechanical stage. The attachable mechanical stage serves all purposes and is the type generally used. It consists of a vertical frame firmly attached to a horizontal frame, the latter part of the apparatus being equipped with slide clips. Movement of the frames in vertical and horizontal directions is secured by milled wheels attached to geared pinions, the teeth of which are fitted to racks upon the frames. Each frame bears a graduated scale which, in combination with a vernier, reads

to 0.1 millimeter. After the accuracy of these scales is checked by comparison with a stage micrometer, they may be used for the approximate measurement of fairly large objects. The diameter of the microscope field with different combinations of objectives and oculars may be ascertained by placing an object at the edge of the field, noting the scale reading, then moving the object to the opposite edge of the field and making a second scale reading. The difference in readings will give the diameter of the field with a given combination of lenses.

#### MICROMEASUREMENTS

Occasionally it is necessary to ascertain the dimensions of cells and cell contents. This may be accomplished by several methods, but the accessories usually employed for this purpose are the ocular micrometer and the filar micrometer. Ocular micrometers, while not as accurate as the filar types, are less expensive and sufficiently accurate for all but the most critical observations.

**Ocular Micrometer.**—This apparatus consists of a glass disk of proper size to fit within the ocular mounting and having a graduated scale ruled upon its surface. The number of scale divisions varies; but, as a rule, the fifth and tenth lines are longer than the others. As the value of these scale divisions varies with different microscopes and combinations of lenses, it is necessary to standardize the ruling by comparing it with a stage micrometer scale. The stage micrometer is a slide upon which is etched an accurately ruled scale 1 or 2 millimeters in length, each millimeter being divided into 100 parts.



**Standardization of Ocular Micrometers.**—In standardizing micrometers the tube length should be adjusted at 160 millimeters. Place the ocular micrometer slip in the ocular so that it rests upon the diaphragm of the latter. Place the stage micrometer on the stage and focus so that the rulings are clear. Move the stage micrometer slide and turn the ocular

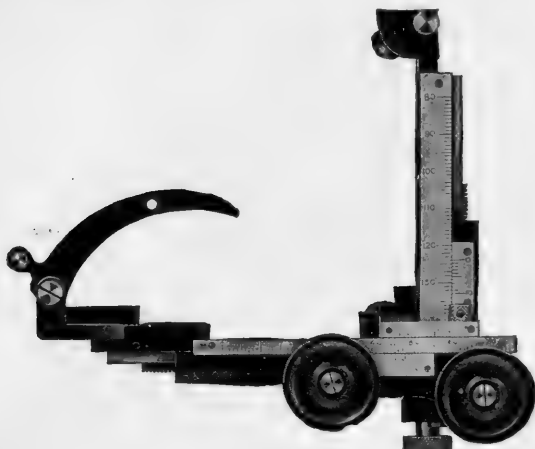

FIG. 70.—Mechanical Stage.

(Bausch & Lomb.)

until the stage and ocular scales correspond and the end line of the ocular scale coincides with a line of the stage micrometer ruling. Count the number of spaces of the stage scale covered by the entire number of ocular micrometer lines. Divide the number of stage micrometer lines covered by the total number of ocular scale divisions. The quotient equals the value in millimeters of each line of the ocular scale.

**Example.**

100 divisions of ocular scale cover 56 of the stage scale.

1 division of stage scale equals 0.01 millimeter.

56 divisions of stage scale equals 0.56 millimeter.

100 divisions of ocular scale equals 0.56 millimeter.

1 division of ocular scale equals 0.0056 millimeter.

In standardizing ocular micrometers with high-power objectives it often happens that the end lines of

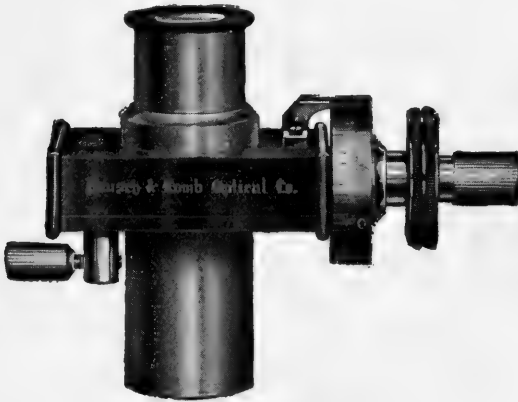

FIG. 71.—Filar Micrometer.

(Bausch & Lomb.)

the ocular micrometer fall between lines of the stage micrometer. This difficulty may be overcome by making slight changes in the tube length until the lines of both micrometers coincide. Micrometer values must be established for each combination of objectives and oculars, and the tube length must be constant for each valuation. Record should be made of the micrometer values and tube lengths with the different combinations.

**Filar Micrometers.**—This type of micrometer consists of an ocular fitted with a movable scale or hair line, which, when a graduated drum is revolved, traverses a fixed scale. The micrometer ocular replaces the ocular of the microscope, and the mounting is usually provided with a set screw to prevent the apparatus turning in the draw tube. The scale and drum rulings of a filar micrometer must be standardized against a stage micrometer in the manner described in the preceding section. Filar micrometers are much more accurate than the disk types; but as they are integral parts of the ocular, one is limited, in using them, to the single ocular in which the scale is mounted. Disk micrometers may be transferred from one ocular to another of different power, and one scale may be standardized for use with a wide range of oculars.

The unit of measurement in microscopy is the micron ( $\mu$ ), which is equivalent to 0.001 millimeter (1/2500 inch), and the dimensions of microscopic objects are expressed in microns.

#### CAMERA LUCIDA

This accessory is used in the preparation of sketches or drawings of microscopic objects. The essential parts of the apparatus are a prism and a mirror. The reflecting apparatus is so placed that the observer may see the specimen and the drawing surface at the same time. In brief, the instrument serves to combine the image produced by the microscope with a view of the drawing surface. One of the reflecting elements is a cube consisting of two triangular glass prisms separated from each other by a silvered surface.

This silvered surface shows a small perforation in line with the optic axis of the microscope lenses,



FIG. 72.—Camera Lucida, Adjustable Mirror Type.  
(Bausch & Lomb.)

thus permitting passage of light rays through the silvered surface to the eye. The other reflecting element is an adjustable mirror supported on a bar



FIG. 73.—Camera Lucida, Fixed Mirror Type.  
(Bausch & Lomb.)

extending at right angles to the optic axis of the microscope. This mirror reflects the image of the drawing paper to the silvered surface of the glass prism, which

in turn acts as a mirror and transmits the view of the drawing paper to the eye. At the same time views of the microscope image are apparent through the perforation in the silvered surface.

The mirror should be adjusted at an angle of 45 degrees from the optic axis, and the drawing surface should be horizontal and level. Where these adjustments interfere with the proper projection of the image the angle of the mirror may be slightly reduced. If the angle of the mirror is varied from 45 degrees, the outer edge of the drawing board must be tilted toward the microscope, the drawing surface being raised twice as many degrees as the mirror is depressed. Certain types of instruments are equipped with slips of slightly darkened glass which are interposed between the prism and the mirror. As the drawing surface is usually white it reflects an excess of light, and this condition is overcome by use of the darkened glass disks.

#### POLARIZING APPARATUS

Although the polarizing microscope is extensively used in chemical microscopy, comparatively little has been done in the adaptation of the apparatus to the field of histology. In order to comprehend the working of the polarizing apparatus one must keep in mind certain physical concepts of light. Ordinary light rays, emanating from the sun or other sources, are in the form of innumerable waves or vibrations of various and constantly changing direction. Certain transparent and translucent materials possess the property of separating light waves and permitting only those which are parallel to a given plane to pass.

This phenomenon is termed *polarization*, and the light rays emerging from these materials constitute polarized light. Calcite or Iceland spar is the material used in the construction of polarizing apparatus. The calcite is cut into long rhombic prisms (*nicol prisms*), which are then cut obliquely and cemented together with Canada balsam. These prisms transmit certain light rays with but slight refraction, so that they pass through both parts of the nicol and are visible. Other light rays are refracted to such an extent that, upon striking the cemented surface between the prisms, they are totally reflected and are not visible at the upper surface of the nicol. The totally refracted light waves are termed *ordinary rays*, while the waves which are so slightly refracted that they pass through both prisms are termed *extraordinary rays*.

A complete polarizing apparatus consists of two nicol prisms, the *analyser*, which is placed below the object under observation, and the *polarizer*, which is placed above it. The mountings of both polarizer and analyser may be graduated, and either or both may be so arranged as to rotate easily. A graduated rotating stage provided with centering devices is necessary in all but the most superficial observations. Upon rotating the polarizer one observes that the field becomes alternately light and dark. It will be further noted that, starting with a field of maximum darkness, rotation through an angle of 90 degrees will be required to secure a field showing maximum brightness. If the prisms are so placed that the light rays passing through them are parallel, a light field results, and the nicols are said to be in the *uncrossed*

*position.* If one of the prisms is rotated so that the light rays passing through it are not parallel with those passing through the other prism, a dark field results, and the nicols are said to be in the *crossed position.* If the mounting of the polarizer is graduated the prism should be so arranged that fields of maximum darkness are visible at 90 and at 270 degrees.

The polarizing apparatus is used in the determination of optical and crystallographic properties of different substances. For these observations the prisms should be set in a crossed position. All transparent and translucent materials may be classified according to the characters they exhibit when viewed between crossed nicols. *Isotropic* or singly refracting substances do not polarize or change the direction of light rays, and therefore show no change when rotated between crossed prisms. Crystals of the isometric type and most amorphous substances are isotropic. The isotropic vegetable tissues and cell contents include cork, epidermis, parenchyma, inulin and oil globules. *Anisotropic* or doubly refracting substances polarize or change the direction of light rays and therefore become alternately light and dark upon rotation between crossed nicols. Most crystalline chemical substances, excepting those of isometric form, are anisotropic. The vegetable tissues and cell contents which act similarly to anisotropic substances include fibers, vessels, calcium oxalate crystals, starch and mucilage deposits.

In certain anisotropic substances the property of double refraction is barely apparent and only neutral gray tints are visible upon rotation. In these instances a thin plate of selenite is interposed between

analyser and polarizer. The selenite disk should be so placed that its plane of vibration is at an angle of 45 degrees to, or midway between, the planes of vibration of the crossed prisms. The field will now appear purple-red in color, and the change caused by

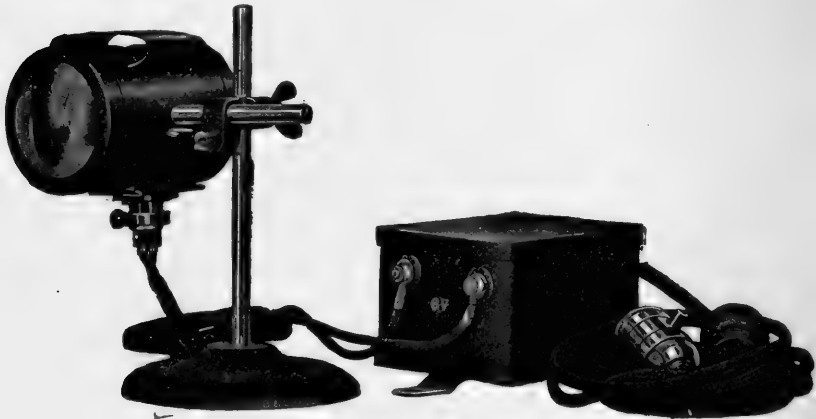

FIG. 74.—Adjustable Microscope Lamp.  
Low-voltage lamp used with rheostat or transformer.  
(Bausch & Lomb.)

rotating weakly polarizing substances will be more apparent because of the greater contrast.

#### MICROSCOPE LAMPS

Gas or electricity may be used as a source of light for microscopic illumination. To obtain satisfactory illumination with gas, it is best to use burners equipped with inverted mantels. Burners of this type give a fairly steady light, free from shadows cast by fixtures or other interfering objects. The ordinary open flame gas burners are unsatisfactory because of the unsteadiness of the light.



The electric illuminating devices include arc and filament lamps. The electric arc furnishes the most intense illumination, and is especially useful in microphotography, owing to the actinic quality of this light. Arc lamps can only be used in conjunction with a rheostat or current control device, and one must look to adjustment of the carbons at frequent intervals. While the light from filament lamps is not as intense as that of the electric arc, it is sufficient for practically all purposes. Low-voltage types of filament lamps require a rheostat or resistance device. High-voltage lamps are more convenient in that they can be directly connected with the source of current. Condensing lenses are usually interposed between the lamp and the microscope, so that the light rays may be concentrated within a small area. In long-continued observations, electric illumination is often more desirable than daylight because of its constant intensity and the ease with which it may be regulated.



FIG. 75.—Drawing Apparatus with Adjustable Lamp.  
(Bausch & Lomb.)

## APPENDIX

### FORMULÆ

#### ACID ALCOHOL:

Conc. Hydrochloric Acid.....	0.5 mil
Alcohol, to make.....	100.0 mils

#### ALCOHOL, GLYCERIN, WATER MIXTURE:

Used as a temporary mounting medium and for maceration of materials.

Alcohol,  
Glycerin,  
Distilled Water, equal parts by volume.

#### ALKANNIN SOLUTION:

##### Formula A

Alkanet root.....	20 grams
Water.....	100 mils

Macerate for several days. Filter and dilute with equal parts of water before using.

##### Formula B

Alkannin dissolved in absolute alcohol. Add equal parts of water and filter before using.

#### ALPHA NAPHTHOL:

Alpha Naphthol.....	20 grams
Alcohol, to make.....	100 mils

#### ANILINE DYES:

Saturated alcoholic solution of dye.....	5 mils
Distilled Water, to make.....	100 mils

#### ANILINE WATER SAFRANIN:

##### 1. Aniline water.

Saturate distilled water with aniline by vigorous shaking.

##### 2. Safranin, saturated alcoholic solution.

Mix equal volumes of 1 and 2 and filter before using. This reagent should be freshly prepared.

**ALTMAN'S PICRIC ACID:**

Picric Acid.....	8 grams
Alcohol, to make.....	100 mls

Dilute with two volumes of water before using.

**BOUIN'S FLUID:**

Fixing agent for animal and vegetable materials.

Picric acid, saturated alcoholic solution.....	200 mls
Formalin.....	80 mls
Glacial Acetic Acid.....	15 mls

Time required is two to five days. After fixing, wash the specimens with 50 per cent alcohol until the latter fails to show yellow coloration.

**CHROMIC ACID:**

Chromic Acid.....	1 gram
Distilled Water, to make.....	100 mls

**CHLORAL HYDRATE:**

Chloral Hydrate.....	80 grams
Distilled Water.....	50 mls

**CLEANING FLUIDS FOR GLASSWARE AND SLIDES:**

Conc. Nitric Acid.....	1 part
Conc. Hydrochloric Acid.....	4 parts

Uncovered glass containers must be used for this mixture and, owing to the corrosive fumes liberated, vessels containing glassware and cleaning fluid must be kept under a hood or in the open air. After immersion for a few hours the glassware should be well washed in water.

Potassium dichromate.....	20 grams
Water.....	100 mls
Conc. Sulphuric Acid.....	100 mls

Dissolve the dichromate in the water, add the acid cautiously and in small portions, cooling the mixture between each addition. The mixture must be stored in glass containers and may be repeatedly used until the color changes. Immersion for a few hours followed by washing in water will serve to clean slides and covers.

**CLEARING AGENTS:**

Clove, Lemon, Turpentine, Bergamot and Sassafras Oils,  
Liquefied Phenol,  
Xylol,  
Chloroform,  
Canada Balsam in Xylol.

**CUPRAMMONIA, (AMMONIACAL COPPER) (SCHWEITZER'S REAGENT)  
(CUOXAM):****Formula A**

Copper Sulphate..... 15 per cent aqueous solution  
Sodium Hydroxide..... 3 per cent aqueous solution

Add slight excess of the hydroxide solution to the copper sulphate solution. Wash the precipitate by decantation and dissolve it in concentrated ammonia water.

**Formula B**

Cover small pieces of metallic copper with 15 per cent ammonia water. Allow the mixture to stand in an open vessel for several days. Filter through glass wool.

**CUPRIC ACETATE:**

Cupric Acetate..... 15 grams  
Distilled Water, to make..... 100 mls

**DELAFIELD'S HEMATOXYLIN:**

Hematoxylin..... 4 grams  
Alcohol..... 25 mls  
Ammonia Alum..... 50 grams  
Glycerin..... 100 mls  
Methyl Alcohol..... 100 mls  
Distilled Water..... 400 mls

Dissolve the hematoxylin in the alcohol and the alum in the water. Mix these solutions and allow to stand exposed to light and air for five days. Filter, add the glycerin and methyl alcohol and allow to stand exposed to light for five days. Finally filter and store for use. This stain improves upon keeping.

**FEHLING'S SOLUTION (ALKALINE CUPRIC TARTRATE):****Alkaline Tartrate Half.**

Rochelle Salt..... 17.3 grams  
Sodium Hydroxide..... 5.0 grams  
Distilled Water, to make..... 50.0 mls

**Copper Half.**

Copper Sulphate.....	3.4 grams
Distilled Water, to make.....	50.0 mls

Mix equal parts of each solution.

**FERRIC CHLORIDE:**

Ferric Chloride.....	1.0 gram
Distilled Water.....	100.0 mls

**FIXING FLUIDS:**

Refer to Bouin's Fluid, Chromic Acid, Formalin, Mercuric Chloride, Picric Acid, Picric Sulphuric Acid and Zenker's Fluid.

**FORMALIN:**

Used as a preservative and fixing fluid for animal and vegetable tissues.

Formalin.....	10 mls
Water.....	90 mls

Time required for fixing is two to five days. This solution is not always thorough in its fixing action and sometimes interferes with staining.

**GLYCERIN JELLY:**

Gelatin.....	10 grams
Glycerin.....	70 mls
Water.....	60 mls
Liquefied Phenol.....	1 mil

Soak the gelatin in water until soft; add the glycerin and gently warm until thoroughly dissolved. Add the phenol and filter through glass wool.

**IODINE POTASSIUM IODIDE (DILUTE LUGOL'S SOLUTION):**

Iodine.....	0.35 gram
Potassium Iodide.....	1.50 grams
Distilled Water, to make.....	100.00 mls

**MERCURIC POTASSIUM IODIDE (MAYER'REAGENT):**

Mercuric Chloride.....	1.35 grams
Potassium Iodide.....	5.00 grams

Dissolve the mercuric chloride in 60 mls of distilled water and the iodide in 10 mls of distilled water. Mix these solutions and add water to make 100 mls.

**MACERATING MIXTURE:**

Refer to Schulze's Macerating Mixture.

**MERCURIC CHLORIDE:**

Mercuric Chloride.....	0.5 gram
Alcohol or Distilled Water, to make.....	100.0 mils

**MILLON'S REAGENT:**

Mercury.....	10 mils
Conc. Nitric Acid.....	90 mils

Dissolve the mercury in the acid and dilute this solution with an equal volume of water before using. This reagent easily decomposes, and but small quantities should be prepared.

**PHENYLHYDRAZINE MIXTURE:**

Phenylhydrazine Hydrochloride.....	3 grams
Sodium Acetate.....	4 grams
Distilled Water.....	10 mils

**PHLOROGLUCIN:**

Phloroglucin.....	0.1 gram
Alcohol.....	10.0 mils

This reagent decomposes upon standing.

**PICRIC ACID:**

Saturated alcoholic or aqueous solution.

**PICRIC SULPHURIC ACID:**

Picric Acid, saturated aqueous solution.....	98 mils
Concentrated Sulphuric Acid.....	2 mils

**PYROGALLOL:**

Pyrogallol.....	0.1 gram
Alcohol.....	5.0 mils
Conc. Hydrochloric Acid.....	5.0 mils

This reagent decomposes upon standing.

**SCHULZE'S MACERATING MIXTURE:**

Concentrated Nitric Acid with the addition of small amounts of Potassium Chlorate.

**ZENKER'S FLUID:**

Used as a fixing agent for animal tissues.

Mercuric Chloride.....	5 grams
Potassium Dichromate.....	1 gram
Sodium Sulphate.....	1 gram
Water.....	100 mls

Add 5 mls Glacial Acetic Acid before using.

Time required for fixation is from one to three days. After fixing, the specimen should be washed in running water for at least twelve hours. Transfer to 50 per cent alcohol for three hours, then to 65 per cent alcohol and finally to 80 per cent alcohol, to which has been added sufficient concentrated iodine potassium iodide solution to give the alcohol a dark brown color. The purpose of the iodine is to remove traces of the mercurial salts which tend to precipitate in the cells. If the iodine alcohol mixture is decolorized, it must be renewed. After two or three days the material is transferred to fresh 80 per cent alcohol, which is changed frequently until all iodine is removed from the specimen.

**ZINC CHLORIODIDE:**

Zinc Chloride.....	25 grams
Potassium Iodide.....	8 grams
Iodine.....	1 gram
Distilled Water, to make.....	15 mls

TABLE OF MAGNIFICATIONS  
(Adapted from Catalogues of Bausch & Lomb, Leitz and Spencer.)

OBJECTIVES. mm.	OCULARS.							OBJECTIVES. mm.
	American (diameters) Continental (empirical) English (inches)	2.5x 1 2	5x 2 1½	7.5x 3 1½	10x 4 1	12.5x 5 ¼	15x 6 ¾	
32		10	20	30	40	50	60	80
16		25	50	75	100	125	150	200
8		50	100	150	200	250	300	400
4		110	215	320	430	560	660	880
3		144	285	420	570	740	900	1200
1.9		238	475	720	950	1260	1425	1900
1.5		410	545	870	1090	1310	1635	2180

TABLE OF OBJECTIVES

Metric (millimeters).....	32	25	16	12	8	5	4	3	1.9	1.5
English (inches).....	1½	1	¾	½	¼	⅓	⅔	⅓	⅓	⅓
Continental (numbers).....	1	2	3	4	5	6	7	8	9	10
Numerical Aperture.....	.08	.25	.25	.40	.50	.70	.85	.85	.87	1.20
Working Distance (mm.)..	38	9.5	7.0	1.8	1.6	1.5	0.3	0.2	.16	.11
Real Field Diameter (mm.)	5.5	3.3	2.1	1.4	1.0	0.5	0.4	0.3	.24	.23
Objective Magnification...	4	6	10	15	20	36	43	57	70	85



## COVER-SLIPS

## COMMON SIZES, THICKNESSES, SHAPES AND DESIGNATIONS

(Adapted from Catalogue, Spencer Lens Co.)

Designation.	Thickness.	Shapes.	Sizes Manufactured.
No. 0 . . . . .	less than 0.13 mm.	Squares, Circles	13, 16, 18, 22, 25 mm.
No. 1 . . . . .	0.13 to 0.17 mm.	Squares, Circles	13, 16, 18, 22, 25 mm.
No. 2 . . . . .	0.17 to 0.25 mm.	Squares, Circles	13, 16, 18, 22, 25 mm.
No. 3 . . . . .	0.25 to 0.50 mm.	Squares, Circles	13, 16, 18, 22, 25 mm.

## APPROXIMATE NUMBER OF COVERS PER OUNCE

Circles.	13 mm.	16 mm.	18 mm.	22 mm.	25 mm.
No. 0 . . . . .	855	550	375	254	214
No. 1 . . . . .	564	362	280	182	142
No. 2 . . . . .	444	286	195	157	112
No. 3 . . . . .	372	240	166	122	93
Squares.					
No. 0 . . . . .	700	450	312	208	176
No. 1 . . . . .	462	296	206	150	116
No. 2 . . . . .	364	234	162	120	92
No. 3 . . . . .	306	196	136	100	76

## REFERENCE BOOKS

## GENERAL:

- United States Pharmacopœia, IX.
- National Formulary, IV.
- National Standard Dispensatory; Hare, Caspari, Rusby.
- United States Dispensatory; Wood, Remington, Sadtler.
- The Microscope, Gage.
- Elements of Applied Microscopy, Winslow.
- The Microscope and its Revelations, Carpenter-Dallinger.

## BOTANY:

- Text Book of Botany; Strassburger, Noll, Schenck and Karsten.
- Manual of Botany, Rusby.
- Applied and Economic Botany, Kraemer.

## MICROSCOPY OF FOODS:

- Microscopy of Vegetable Foods, Winton.
- Microscopy of Technical Products, Hanausek-Winton.
- Bacteriology and Mycology of Foods, Tanner.
- Food Microscopy, Clayton.

## MICROSCOPY OF DRUGS:

- Scientific and Applied Pharmacognosy, Kraemer.
- Powdered Drugs, Schneider.
- Histology of Medicinal Plants, Mansfield.
- Powdered Drugs, Greenish.

## MICROCHEMISTRY:

- Botanical Microchemical Technic, Zimmerman.
- Elementary Chemical Microscopy, Chamot.
- Microchemistry of Poisons, Wormley.

# INDEX

(Figures preceded by an asterisk (\*) indicate pages upon which illustrations appear)

## A

Abbé camera lucida, 53, 217, \*218  
— condenser, 40, \*40  
Aberration, chromatic, 30, \*30  
—, spherical, 29, \*29  
Absorption of gases, 115  
— — water, 113  
—, tissues for, 113  
Achromatic lenses, 30  
Acicular crystals, 146, \*149  
Acid alcohol, 224  
— -fast stains, 67  
Air bubbles, \*51, 52  
Alcohol, glycerin, water mixture,  
16  
Aleurone, 64, 135, \*147, 150,  
\*200, \*203, \*208, \*210  
— cells, \*200, \*203, \*208, 209,  
\*210  
—, forms of, 150  
—, reactions for, 64  
Alkaline cupric tartrate solution,  
226  
Alkaloids, 62, 146  
—, reactions for, 62  
Alkannin solution, 224  
Alpha naphthol solution, 224  
Altman's picric acid solution, 225  
Ammoniacal copper solution, 226  
Analyzer, 220  
Aniline dyes, 66  
— safranin, 224

Anisotropic, 221  
— cell contents, 221  
— tissues, 221  
Annual stems, 163  
Annular ducts, 121, \*123  
Aplanatic lenses, 31  
Appearances of ray cells, 126,  
179, \*180, \*181  
Apposition, growth by, 73  
Arid, 206  
Arm of microscope, \*42, 43  
Assimilation starch, 134  
— tissues, 132  
Attraction bodies, \*75, 76

## B

Bark, 170, \*172, \*173  
—, cell contents in, 177  
—, cork of, 101, \*102, 171  
—, definition of, 170  
—, formation of, 80  
—, medullary rays in, \*172, \*173,  
176  
— parenchyma, 176  
—, phelloderm, 171  
—, phellogen, 101, \*102, 171  
— phloem, elements in, 176  
—, stone cells in, 171, 176  
—, structures, 170  
— structures in roots, 158, \*172  
— — in stems, 170, \*173  
Base of microscope, \*42, 43

Bast fibers, 80, \*106, \*107, 108  
 Beaded walls, 89, \*91, \*93, 187  
 Beaked starch grains, 143, \*145  
 Bicollateral bundles, \*128, 131  
 Bifacial leaves, 187  
 Biseriate hairs, \*98, 99  
 Bordered pores, 122  
 Bordering cells, 117  
 Bork, 81  
 Bouin's fluid, 225  
 Bract tissues, 192  
 Branched fibers, 105, \*116  
 — hairs, 95, \*98  
 — stone cells, \*109, 110  
 Brownian movement, 52  
 Bubbles, air, \*51, 52  
 Bundles, bicollateral, \*128, 131  
 —, collateral, \*128, 129  
 —, concentric, 129, \*130  
 —, fibrovascular, 80, 127  
 — of roots, 80, 156  
 — — stems, 83, 84, 168  
 —, phloem, 80  
 —, radial, 129, \*130, 156  
 —, xylem, 80

## C

Calcium carbonate, 65, 148  
 — —, forms of, \*147, 148  
 — —, reactions for, 65  
 — oxalate, 63, 146  
 — —, formation of, 136  
 — —, forms of, 146, \*149  
 — —, reactions for, 63  
 Calyx tissues, 192  
 Cambium, 81, 129, \*159  
 — of root, 161  
 — of stem, 168  
 Camera lucida, 53, 217, \*218  
 — —, adjustment of, 219  
 Canada balsam, 21  
 — —, mounts, 23

Cautions in focusing, 49  
 Cell, 70, \*71  
 —, origin of, 70  
 — sap, 72  
 — wall, 73  
 Cell contents, 142, \*145, \*147, \*149  
 — —, chemical properties of, 60  
 — —, classification of, 142  
 — —, nonprotoplasmic, 72, 142  
 — — of barks, 177  
 — — — cork cells, 101  
 — — — ducts, 122  
 — — — fibers, 105, 141  
 — — — flowers, 196  
 — — — fruits, 205  
 — — — leaves, 190  
 — — — medullary rays, 126  
 — — — roots, 162  
 — — — seeds, 212  
 — — — sieve tubes, 124  
 — — — stems, 168  
 — — — woods, 182  
 — —, protoplasmic, 71, \*71  
 Cell walls, 73  
 — —, chemical properties of, 58  
 Cellulose, 58  
 —, reactions for, 58  
 —, reserve, 136  
 —, stains for, 68  
 Centric hilum, 143, \*145  
 Centrosomes, 76  
 Changes in mitosis, 74, \*75  
 Chemical reactions of cell contents, 60  
 — — — cell walls, 58  
 — — — plant tissues, 57  
 Chloral hydrate solution, 225  
 Chlorophyll, 134  
 Chloroplasts, 72, 132  
 Chloroplastids, 72, 188  
 Chromatic aberration, 30, \*30

- Chromatin**, 72  
**Chromatophores**, 72  
**Chromic acid solution**, 225  
**Chromoplastids**, 72  
**Chromosomes**, \*75, 76  
**Classification of cell contents**, 142  
 — — fibers, 108  
 — — plant hairs, 94  
 — — starch grains, 143  
 — — stone cells, 110  
**Cleaning fluids**, 225  
 — glassware, 20  
 — mixtures, 225  
 — the microscope, 50  
**Clearing**, 4  
 — agents, 4, 226  
**Closed collateral bundles**, \*128, 129  
**Coarse adjustment**, \*42, 43  
**Coating mixture**, 14  
**Collateral bundles**, \*128, 129  
**Collenchyma**, 112, 167  
 —, forms of, \*111, 112  
 —, functions of, 112, 141  
**Collenchymatic tissues**, 112, 141, 189  
**Colloidal cell contents**, 142  
**Complete fibrovascular bundles**, 81, \*82, 127  
**Compound hairs**, 95, \*98  
 — microscope, 33, \*42  
 — —, optics of, 33, \*34  
 — —, parts of, 33, \*42  
 — starch grains, 135, 143, \*145  
**Concave lens**, 25, \*26  
**Concavoconvex lens**, 25, \*26  
**Concentric bundles**, 129, \*130  
**Condenser**, Abbé, 39, \*40  
**Condensing lenses**, 39  
**Conducting tissues**, 120, \*123  
 — —, derivation of, 79  
**Contents of definite form**, 142  
**Contents of ducts**, 122  
 — — fibers, 105, 141  
 — — glandular hairs, 137  
 — — indefinite form, 142  
 — — latex tubes, 126  
 — — medullary rays, 126  
 — — secretion cavities, 140  
 — — secretion cells, 140  
 — — sieve tubes, 124  
 — — stone cells, 110  
**Continental objectives**, 35  
 — oculars, 38  
**Convex lens**, 25, \*26  
**Convergent meniscus lens**, 25  
**Convexoconcave lens**, 25, \*26  
**Cork**, 101, \*102  
 — cells, forms of, 101, \*102  
 — of bark, 171, \*172, \*173  
 — — root, 158, \*172  
 — tissues, 101, 171  
**Corolla tissues**, 194  
**Cortex**, primary, 79  
**Cortical parenchyma**, \*78, 79, 140, 154, 160, 167, 176  
**Covering tissues**, \*78, 87  
**Coverglasses**, 19  
**Coverslips**, designations, 231  
 —, number to the ounce, 231  
 —, sizes of, 231  
 —, thickness of, 231  
**Cremocarps**, 198, \*200  
 —, endocarp tissues, 201  
 —, exocarp tissues, 199  
 —, fibrovascular tissues, 201  
 —, mesocarp tissues, 199  
 —, vittae, 140, 199  
**Cross-section**, 7  
**Crossed prisms**, 221  
**Cryptocrystalline crystals**, 146, \*149  
**Crystals**, 146, \*149  
 —, acicular, 146, \*149

- Crystals, crypto-crystalline, 146, \*149  
 —, cubical, 146, \*149  
 —, forms of, 146, \*149  
 —, micro, 146, \*149  
 —, prismatic, 146, \*149  
 —, raphides, 146, \*149  
 —, rosette, 146, \*149  
 Crystal-bearing fibers, 105, \*107  
 — sand, 146  
 Crystalline cell contents, 142, \*149  
 Crystalloids, 64, \*147  
 Cuoxam, 226  
 Cuprammonia, 226  
 Cupric acetate solution, 226  
 Curling of sections, 14  
 Cutin, 59, 88  
 —, stains for, 68  
 Cutinized cell walls, 59, 88, 184  
 Cystoliths, \*147, 148  
 Cytology, 71
- D
- Dehydration, 3  
 Delafield's hematoxylin, 226  
 Dermatogen, 77, \*78  
 Diaphragm, 41, \*42  
 Dicotyledonous rhizomes, 183  
 — roots, 158, \*159  
 — stems, 163  
 Differential staining, 68  
 Dissecting microscope, 31, \*31, \*32  
 Divergent meniscus lens, 25, \*26  
 Double concave lens, 25, \*26  
 — convex lens, 25, \*26  
 — staining, 67  
 Drawings, 52  
 —, apparatus for, 52, \*218  
 —, incorrect methods, \*55, 56  
 Draw tube, \*42, 43
- Drupaceous fruits, 201, \*203, \*204  
 — endocarp tissues, 202  
 — exocarp tissues, 201  
 — fibrovascular tissues, 202  
 — mesocarp tissues, 202  
 Ducts, 120  
 —, annular, 121, \*123  
 —, contents of, 122  
 —, derivation of, 79  
 —, direction of conduction, 122  
 —, pitted, 121, \*123  
 —, reticulate, 121, \*123  
 —, scalariform, 121, \*123  
 —, spiral, 121, \*123  
 —, structure of, 120  
 —, walls of, 121
- E
- Embedding dried materials, 16  
 — fresh materials, 15  
 — noninfiltrated specimens, 15  
 — paraffin, 6  
 Embryo, 206  
 Emergences, 99  
 Endocarp, 198, \*200  
 Endodermis of root, \*78, 79, \*128, \*130, \*153, 155  
 — — stem, 83, \*165, 167  
 Endosperm, \*200, \*203, 206, \*207, \*210, 211  
 English objectives, 35  
 Epicalyx, 192  
 Epicarp, 198, \*200, \*203  
 Epidermal cells, forms, 89, \*90, \*91, \*93  
 — tissues, 88  
 Epidermis of leaf, \*90, \*91, 184  
 — — root, 152, \*153  
 — — seed, 92, \*93, 206, \*208, \*210  
 — — stem, 83, 166

Epidermis of stigma, \*193, 195  
 —, primary, 79, 83, 152, 166  
 Equivalent focal length, 36  
 Errors in sketching, 55, \*55  
 Excentric hilum, 143, \*145  
 Exocarp, 198  
 Extraordinary ray, 220  
 Eye point, \*34, 50  
 Eyes, use of, 49

F

Fats, 65, 148  
 —, reactions for, 65  
 Fehling's solution, 226  
 Ferric chloride solution, 227  
 Fibers, bast, 80, \*106, \*107, 108  
 —, branched, 105, \*107  
 —, cell contents, 105, 141  
 —, classification, 108  
 —, crystal-bearing, 105, \*107  
 —, derivation *c.f.*, 79  
 —, forms of, \*106, \*107  
 —, lumen of, 105  
 —, porous, 105, \*106, \*107, 108  
 —, striated, 105, \*106, \*107, 108  
 —, wood, \*106, 108  
 Fibrous tissues, 105  
 — —, functions, 104  
 Fibrovascular bundles, \*78, 80,  
 \*82, 127  
 — —, collateral, \*128, 129  
 — —, complete, 81, \*82, 127  
 — —, concentric, 129, \*130  
 — —, derivation of, 80  
 — —, incomplete, \*78, 81, 127  
 — — of leaves, 189  
 — — — roots, 80, 81, 156, 160  
 — — — stems, 83, 84, 168, 176,  
 178  
 — —, radial, 129, \*130, 156  
 Filar micrometer, \*216, 217  
 Fine adjustment, \*42, 44

Fissured hilum, 144  
 Fixing fluids, 2, 227  
 Fixation, 2  
 Flower structure, 191, \*193  
 Flowers, bract tissues, 192  
 —, calyx tissues, 192  
 —, cell contents, 196  
 —, corolla tissues, 194  
 —, pistil tissues, 195  
 —, stamen tissues, 194  
 —, stem tissues, 196  
 Focal distance, 26, \*28, \*29  
 — length, 26, \*28, \*29  
 Focusing cautions, 49  
 — high powers, 48  
 — low powers, 46  
 — technic, 49  
 Formalin solution, 2, 16, 227  
 Formation of image in micro-  
 scope, \*34  
 — — real image, 27, \*28  
 — — starch, 133  
 — — virtual image, 28, \*29  
 Forms of aleurone, \*147, 150  
 — — crystals, \*149  
 — — cystoliths, \*147, 148  
 — — inulin, 144, \*147  
 — — silica, 148  
 — — starch, 143, \*145  
 Formulæ, 224  
 Fruits, cell contents, 205  
 — cremocarps, 198, \*200  
 — —, endocarp tissues, 201  
 — —, exocarp tissues, 198  
 — —, fibrovascular tissues, 201  
 — —, mesocarp tissues, 198  
 — —, vittae, 199  
 —, drupes, 201, \*203  
 — —, endocarp tissues, 202  
 — —, exocarp tissues, 201  
 — —, fibrovascular tissues, 202  
 — —, mesocarp tissues, 202

- Function, 71  
 Functions of collenchyma, 112,  
     141  
 — — cork cells, 103  
 — — ducts, 122  
 — — epidermal cells, 87  
 — — fibers, 104  
 — — flower structures, 196  
 — — fruit structures, 205  
 — — leaf structures, 190  
 — — lenticels, 119  
 — — medullary rays, 124  
 — — mounting media, 19  
 — — parenchyma, 140  
 — — porous parenchyma, 127  
 — — root hairs, 113  
 — — structures, 162  
 — — seed structures, 212  
 — — sieve tubes, 124  
 — — stem structures, 169, 182  
 — — stoma, 115  
 — — stone cells, 104  
 Fundamental tissues, 77, \*78
- G
- Gases, absorption of, 115  
 General stains, 66  
 Glandular hairs, 99, \*100, 137  
 — —, sessile, 99  
 — —, stalked, 99  
 Glassware, cleaning of, 20  
 — — mixtures, 225  
 Globulins, 64  
 Glucosides, 63, 136, 146  
 —, reactions for, 63  
 Gluten cells, 209  
 Glycerin, alcohol, water mixture,  
     16, 20  
 Glycerin jelly, 21, 227  
 — — mounts, 21  
 Growth by apposition, 73  
 — — intussusception, 73
- Guard cells, \*116, 117  
 Gums, 59  
 —, identification of, 60
- H
- Hairs, basal cells, \*97, 99  
 —, biseriate, \*98, 99  
 —, branched, 95, \*98  
 —, compound, 95, \*98  
 —, functions of, 94  
 —, glandular, 99, \*100, 137  
 —, multicellular, 95, \*96, \*97, \*98  
 —, multiseriate, 95, \*97, \*98  
 —, nonglandular, 94, \*96, \*97,  
     \*98  
 — of root, 79, \*116  
 —, papillose, 99  
 —, simple, 95, \*96, \*97, \*98  
 —, terminal cell, 99  
 —, unicellular, 95, \*96  
 —, uniseriate, 95, \*97  
 Hand microtome, 7, 8  
 Hematoxylin, Delafield's, 226  
 Herbaceous stems, 163  
 Hesperidin, 146, \*147  
 Hilum, 135, 143, \*145  
 —, centric, 144  
 —, excentric, 144  
 —, fissured, 144  
 —, line, 144  
 —, stellate, 144  
 Hypodermis, \*78, 79  
 — of leaf, 185, \*185, \*186  
 — — root, 79, \*153, 154  
 — — stem, 83, \*165, 166
- I
- Illumination, artificial light, 222,  
     \*222  
 —, natural light, 46, \*46, \*47  
 Immersion liquids, 37  
 — objectives, 37, \*37



Inclination joint, \*42, 43  
 Inclusions, 72  
 Incomplete bundles, \*78, 80, 127  
 Indirect nuclear division, 74, \*75  
 Infiltration method, 2  
 — —, synopsis, 17  
 — paraffin, 2  
 Interpretation of images, 51  
 Intussusception, growth by, 73  
 Inulin, 61, 135, 144  
 —, forms of, \*147  
 —, reactions for, 61  
 Iodine potassium iodide solution, 227  
 Iris diaphragm, 41, \*42  
 Isotropic cell contents, 221  
 — tissues, 221

## J

Jeweler's magnifier, 31, \*31

## K

Knives, microtome, 10

## L

Latex, 126  
 — tubes, \*125, 126  
 — —, contents of, 126  
 — —, structure of, 126  
 — —, walls of, 126  
 Leaf, 184, \*185, \*186  
 — cell contents, 190  
 — epidermis, 88, \*90, \*91, 184  
 — fibrovascular tissues, 189  
 — hairs, 94, \*96, \*97, \*98, \*100  
 — hypodermis, 185  
 — mesophyll, 188  
 — palisade tissue, 187  
 — parenchyma, 188  
 — structures, 184, \*185, \*186  
 — subepidermal tissues, 89  
 — trichomes, 92, 94, \*96, \*97, \*98, \*100

Lenses, achromatic, 30  
 —, aplanatic, 31  
 —, refraction by, 24, \*27  
 —, types of, 25, \*26  
 Lenticels, 119  
 —, functions of, 119  
 —, structure of, \*116, 119  
 Leucoplastids, 72, 134  
 Lignified cell walls, 58  
 — — —, reactions for, 58  
 Lignin, stains for, 68  
 Lignocellulose, 105  
 Line hilum, 144  
 Linin, 76  
 Longitudinal section, 7  
 Loup, 31, \*31  
 Lumen, 105  
 Lysigenous cavities, 137, \*138

## M

Macerating mixture, 228  
 Magnifications, table of, 230  
 Manufacture of nutrients, 132  
 Mayer's reagent, 227  
 Measurements, filar micrometer, 217  
 —, mechanical stage, 214  
 —, ocular micrometer, 214  
 Mechanical parts of microscope, 41, \*42  
 Mechanical stage, 213, \*215  
 — —, measurements by, 213  
 — —, uses, 213  
 Mechanical tissues, 104  
 Medullary rays, arrangement of, 176, \*180, \*181  
 — —, conduction by, 124  
 — —, contents in, 126  
 — —, derivation of, 80  
 — —, functions, 124  
 — —, in radial section, 179, \*181

- Medullary rays, in tangential section, 179, \*181  
 — —, — transverse section, 179, \*180  
 — —, of barks, \*172, \*173, 176  
 — —, — roots, \*159, 161  
 — —, — woods, 179, \*180, \*181  
 — —, origin of, 80, 124  
 — —, walls of, 124  
 Membranous tissues, 88, 184  
 Mercuric chloride solution, 2, 228  
 Mercuric potassium iodide solution, 227  
 Meristematic tissues, 77  
 Mesocarp, 198  
 Mesophyll, \*185, \*186, 188  
 Methods for sectioning, 1  
 Metric objectives, 36  
 Microcrystals, 146, \*149  
 Micrometers, filar, \*216, 217  
 —, ocular, 214  
 —, stage, 214  
 —, standardization of, 215  
 Micromillimeter, 217  
 Micon, 217  
 Microphotographic apparatus, 52, \*53  
 Microscope, compound, 33, \*42  
 —, dissecting, \*31, \*32, 32  
 —, formation of images by, \*34  
 —, lamps, 222, \*222  
 —, mechanical parts, 41, \*42  
 —, optical parts, 35, \*42  
 —, optics of, \*34  
 —, simple, 31, \*31, \*32  
 Microtome, hand, 7, 8, \*8, \*9  
 —, knives, 10  
 —, razor, 7  
 —, rotary, 8, \*11  
 — sections, 8  
 —, sliding, 8, \*9, \*11  
 —, technic, 12  
 Millon's reagent, 228  
 Mirror, 39, \*42  
 Mitosis, 74, \*75  
 Molds for paraffin, 6, \*6  
 Monocotyledonous rhizomes, \*165, 183  
 — roots, 151, \*153  
 — stems, 163, \*165  
 Mounting in canada balsam, 23  
 — — glycerin jelly, 21  
 — media, 20  
 — of specimens, 19  
 Mucilage cells, \*139, 148, 209  
 Multicellular hairs, 95, \*96, \*97, \*98  
 — organisms, 70  
 Multiseriate hairs, 95, \*97, \*98
- N
- Neighboring cells, \*116, 117  
 Nicol prisms, 220  
 Nonglandular hairs, 94, \*96, \*97, \*98  
 Noninfiltrated specimens, 15  
 Nonprotoplasmic cell contents, 73  
 Nosepiece, \*42, 43  
 Nucleoli, \*71, 72  
 Nucleus, \*71, 72  
 Numerical aperture, 38  
 — —, table of, 230  
 Nutrients, manufacture of, 132
- O
- Object clamp, 8  
 Objectives, \*42  
 —, construction, 35  
 —, correction in, 48  
 —, diameter of field, 230  
 —, immersion, 37  
 —, indication of power, 35  
 —, magnifications, 230  
 —, numerical aperture of, 38, 230

Objectives, parfocal, 48  
 —, sectional views of, \*35  
 —, working distance of, 38, 230  
 Ocular micrometer, 214  
 Oculars, \*42  
 —, construction of, 38  
 —, indication of power, 38  
 Oils, 65, 148  
 Ontogeny, 191  
 Open collateral bundles, \*128, 129  
 Optic axis, 26, \*28, \*29, \*34  
 Optics of compound microscope, \*34  
 — — simple microscope, \*29, 31  
 Optical parts of microscope, 35, \*42  
 Ordinary ray, 220  
 Orientation, 6  
 Origin of cells and tissues, 74

## P

Palisade tissue of leaf, \*185, \*186, 187  
 — — — seed, \*210, 211  
 Papillæ, 94, \*96  
 — of stigma, \*193, 195  
 Papillose hairs, 99  
 Paraffin infiltration, 2  
 — molds, 6, \*6  
 Parallel prisms, 220  
 Parasitic plants, 114  
 Parenchyma, 84  
 —, cortical, \*78, 79, 140, 160  
 — of bark, \*172, \*173, 176  
 — — fruit, 199, \*200, \*203, \*204  
 — — leaf, \*185, \*186, 188  
 — — root, \*153, 154, \*159, 160  
 — — seed, \*208, 209, \*210, 211  
 — — wood, 178, \*180, \*181, 182  
 —, pith, \*78, 80, 84, \*153, 157, \*159, \*165, 168, 182  
 Parenchyma, porous, \*125, 127  
 Parfocal objectives, 48  
 Parts of compound microscope, 33, 42  
 Pectins, 59  
 —, reactions for, 60  
 —, stains for, 69  
 Perforated parenchyma, \*125, 127  
 Periblem, 77, \*78  
 Pericarp, 198  
 Periderm, 101, \*172, \*173  
 Perisperm, 206  
 Permanent mounting media, 21  
 Permanent root tissues, 80, 158  
 Petals, 194  
 Phelloderm, 81, \*82, 160, 171, \*172, \*173  
 Phellogen, 81, \*82, 160, 171, \*172, \*173  
 Phenylhydrazine solution, 228  
 Phloem bundles, \*78, 80, 127  
 — elements in barks, \*172, \*173, 176  
 Phlorglucin solution, 228  
 Photosynthesis, 132  
 Picric acid solution, 2, 228  
 — — —, Altman's, 225  
 Pillar of microscope, \*42, 43  
 Pistil tissues, 195  
 Pith, 80, 84  
 — in woods, 182  
 — of stem, 84, \*165  
 — parenchyma, 80, 84, 127, 140, \*153, 157, \*159, \*165  
 Pitted ducts, 121, \*123  
 Planoconcave lens, 25, \*26  
 Planoconvex lens, 25, \*26  
 Plant cells, 70, \*71  
 Plant hairs, 92, \*96, \*97, \*98, \*100  
 — —, classification, 94

- Plant proteins, 64, 135, 150  
 — respiration, 117  
 — tissues, 70  
 — —, reactions for, 57  
 Plastids, 72  
 Plerom, 77, \*78  
 Polar caps, \*75, 76  
 Polarization, 219  
 Polarized light, 219  
 Polarizer, 220  
 Pollen, \*193, 194  
 Porous fibers, 105, \*106, \*107,  
 108  
 — parenchyma, \*125, 127  
 — stone cells, \*109, 110  
 Primary cortex, \*78, 79, 154  
 — epidermis, \*78, 79, 152  
 — medullary rays, 80, \*82  
 — periderm, 81, \*82  
 — root tissues, 77, \*78, 151  
 — stem structures, 83, 163, \*165  
 Principal axis, 26, \*27, \*28, \*29  
 — focus, 26, \*27, \*28, \*29  
 Prismatic crystals, 146, \*149  
 Prisms, nicol, 220  
 Process, clearing, 4  
 —, dehydrating, 3  
 —, embedding, 6  
 —, fixing, 2  
 —, infiltration, 5  
 Production of real images, 27,  
 \*28  
 — — virtual images, 28, \*29  
 Prosenchyma, 84  
 Protective tissues, 87  
 Protoplasm, 71  
 Protoplasmic contents, 71, \*71  
 Pyrogallol solution, 228
- R
- Radial bundles, 129, \*130  
 — section, 7
- Raphides, 146, \*149  
 Rays, 80, 124, 161, 179, \*180,  
 \*181  
 —, functions of, 124  
 Reactions for aleurone, 64  
 — — alkaloids, 62  
 — — calcium carbonate, 65  
 — — — oxalate, 63  
 — — cellulose, 58  
 — — cutin, 59  
 — — fats, 65  
 — — glucosides, 63  
 — — gums, 60  
 — — inulin, 61  
 — — lignin, 58  
 — — pectins, 60  
 — — resins, 64  
 — — silica, 65  
 — — starch, 61  
 — — suberin, 59  
 — — sugars, 62  
 — — tannin, 64  
 Real images, 27  
 — —, formation of, 27, \*28  
 Reference books, 232  
 Refraction, 19, 24, \*25  
 — in concave lenses, 27, \*27  
 — — convex lenses, 27, \*27  
 Regulation of transpiration, 118  
 Removal of embedding media, 14  
 Reserve cellulose, 112, 141  
 — starch, 134, 143  
 Resins, 64, 148  
 Resolving power, 38  
 Respiration in plants, 117  
 Reticulate ducts, 121, \*123  
 Retina, 24  
 Rhizomes, 183  
 Ribbon carrier, 13, \*13  
 — sections, 13  
 Root bark, 158, \*172  
 — bundles, \*78, \*82, 156

Root cambium, \*82, 161  
 — cap, 79, \*116  
 — cell contents, 162  
 — cork, \*82, 158  
 — endodermis, \*78, 79, 155  
 — epidermis, \*78, 79, 152  
 — hairs, 79, 113, \*116  
 — hypodermis, \*78, 79, 154  
 — medullary rays, 80, \*82, 161  
 — phellogen, 81, \*82, 160  
 — phloem bundles, 80, 155, 160  
 — pith, \*78, 80, 157  
 — structures, 152, \*153, 158, \*159  
 — tissues, primary, 77, 151, \*153  
 — —, secondary, 80, 158, \*159  
 — xylem bundles, \*78, 80, \*82, 156, 160  
 Rosette crystals, 146, \*149  
 Rotary microtome, 10, \*11

## S

Saturation stains, 66  
 Scleriform ducts, 121, \*123  
 Schizogenous cavities, 137, \*138  
 Schlerenchymatic tissues, 108  
 Schultze's mixture, 228  
 Schweitzer's reagent, 226  
 Secondary periderm, 84, \*102  
 — phellogen, 84, \*102, 160  
 — root tissues, 80, \*82, 158  
 — stem tissues, \*82, 83, 169  
 Secreting cavities, 137, \*138  
 — cells, 139, \*139  
 Section cutting, 7  
 —, cross-, 7  
 —, longitudinal, 7  
 —, radial, 7  
 —, tangential, 7  
 —, transverse, 7  
 Sectioning methods, 2, 7

Seed, cell contents, 212  
 —, embryo, 206  
 —, endosperm, 207, 211  
 —, epidermis, 92, \*93, 207, \*208, 209, \*210  
 —, inner epidermis, 207, \*208, 209, \*210  
 —, perisperm, 206  
 — structures, 206, \*208, \*210  
 —, tegmen, 207, \*208, 209, \*210  
 —, testa, 92, \*93, 207, \*208, 209, \*210  
 Selenite plates, 221  
 Sepals, 192  
 Sessile glandular hairs, 99, \*100  
 Sharpening microtome knives, 10  
 Sieve plates, 122, \*125  
 — —, structure of, 122  
 Sieve tubes, 122, \*125  
 — —, contents, 124  
 — —, derivation of, 80  
 — —, direction of conduction, 124  
 — —, structure of, 122  
 Silica, 65, 148  
 Simple hairs, 95, \*96  
 — microscope, 31, \*31  
 — starch grains, 135, \*145  
 Sketching, errors, 54, \*55, 56  
 Sliding microtome, 8, \*9, \*11  
 Specimen block, 6  
 Specimens, clearing, 4  
 —, cutting, 7  
 —, dehydration, 3  
 —, embedding, 6  
 —, fixation, 2  
 —, noninfiltrated, 15  
 —, mounting, 19  
 —, sectioning, 7  
 Spectrum, 30  
 Spherical aberration, 28, \*29

- Spinose pollen, \*193, 195  
 Spiral ducts, 121, \*123  
 Stage, \*42, 43  
 —, mechanical, 213, \*215  
 —, micrometer, 214  
 Stains, acid fast, 67  
 —, double, 67  
 —, formulæ for, 66, 224  
 — for cellulose, 68  
 — — cell walls, 67  
 — — cutin, 68  
 — — gums, 69  
 — — lignin, 68  
 — — pectins, 69  
 — — suberin, 68  
 —, general, 66  
 —, saturation, 66  
 Staining, 66  
 —, differential, 68  
 — solutions, 66  
 Stalked glandular hairs, 99, \*100  
 Stamen tissues, \*193, 194  
 Standardization of micrometers, 215  
 Starch, assimilation, 134  
 —, reactions for, 61  
 —, reserve, 134, 143  
 —, soluble, 134  
 —, synthesis of, 132  
 Starch grains, beaked, 143, \*145  
 — —, classification, 143  
 — —, compound, 135, 143, \*145  
 — —, forms of, \*145  
 — —, hilum, 135, 144, \*145  
 — —, simple, 135, 143, \*145  
 — —, sizes of, 143  
 — —, striated, 135, 144, \*145  
 Stele, 157  
 Stellate hilum, 144, \*145  
 Stem bark, 170, \*173  
 — bundles, \*82, 84, \*165  
 — cambium, \*82, 170  
 Stem cortex, \*82, 167, \*173  
 — endodermis, 83, \*165, 167  
 — epidermis, 83, \*165, 166  
 — hypodermis, 83, \*165, 166  
 — phloem elements, \*82, \*165, 168, \*173, 176  
 — pith, 84, \*165, 168, 182  
 — structures, 163, \*165  
 — tissues in flowers, 196  
 — —, monocotyledonous, 163, \*165  
 — —, primary, \*82, 83, 163, \*165  
 — —, secondary, \*82, 83, 163, 169  
 Stigma epidermis, \*193, 195  
 — papillæ, \*193, 195  
 Stoma, 115, \*116  
 Stomata, 115, \*116  
 —, functions of, 115  
 —, structure of, \*116, 117  
 Stone cells, 110  
 — —, classification, 110  
 — —, forms of, \*109, 110  
 — —, in barks, \*172, \*173, 176  
 — —, storage in, 141  
 Storage tissues, 140  
 Striations, 89, 105, 135, 144  
 Striated fibers, 105, \*106, \*107  
 — starch grains, 144  
 — stone cells, \*109, 110  
 Structure of cell wall, 73  
 Subepidermal cells of leaf, 89, 185, \*185, \*186  
 — — — seed, 209, \*210  
 Suberin, 59  
 —, reactions for, 59  
 —, stains for, 68  
 Suberized cell walls, 59  
 Substage, \*42, 43  
 Sucrose, 62, 135  
 Sugars, 62, 135, 144

Sugars, reactions for, 62  
 Supporting tissues, 104  
 Synthesis of starch, 132  
 —, tissues for, 132

## T

Tables, coverslips, 231  
 —, magnifications, 230  
 —, objectives, 230  
 —, oculars, 230  
 Tangential sections, 7  
 Tannins, 64, 148  
 —, reactions for, 64  
 Tegmen, 206, \*210  
 Temporary mounting media, 20  
 Testa, 206, \*210  
 Tissues, 70  
 —, collenchymatic, \*111, 112, 141  
 —, epidermal, 87, \*90, \*91, \*93,  
 152, 166  
 —, fibrovascular, 80, \*128, \*130  
 — for absorption, 113, \*116  
 — — assimilation, 132  
 — — conduction, 120, \*123, \*125  
 — — storage, 140  
 — — support, 104, \*106, \*107,  
 \*109, \*111  
 — — synthesis, 132  
 —, meristematic, 77  
 — of barks, 171, \*172, \*173,  
 \*174, \*175  
 — — flowers, 191, \*193  
 — — fruits, 198, \*200, \*203,  
 \*204  
 — — leaves, 184, \*185, \*186  
 — — seeds, 206, \*208, \*210  
 — — woods, 177, \*180, \*181  
 —, origin of, 74  
 —, plant, 70  
 —, primary root, 77, \*78, 151,  
 \*153  
 —, — stem, 83, 163, \*165

Tissues, schlerenchymatic, 108  
 —, secondary root, \*78, 80, 158,  
 \*159  
 —, — stem, \*78, 83, 169  
 Tracheæ, 120, \*123  
 —, annular, 121, \*123  
 —, pitted, 121, \*123  
 —, reticulate, 121, \*123  
 —, scalariform, 121, \*123  
 —, spiral, 121, \*123  
 —, structure of, 121  
 —, walls of, 121  
 Tracheids, 122  
 Transpiration, 118  
 —, regulation of, 118  
 Transverse section, 7  
 Trichomes, glandular, 99, \*100,  
 137  
 —, nonglandular, 94, \*96, \*97,  
 \*98  
 Tube of microscope, \*42, 43  
 Types of crystals, \*149  
 — — lenses, 25, \*26

## U

Uncrossed prisms, 220  
 Unicellular hairs, 95, \*96, \*97,  
 \*98  
 — organisms, 70  
 — secretion cells, 139, \*139  
 Unifacial leaves, 187  
 Uniseriate hairs, 95, \*96  
 Use of microscope, 44  
 Use of the eyes, 49

## V

Vacuoles, \*71, 72  
 Vessels, 120, \*123  
 —, annular, 121, \*123  
 — in leaves, 189  
 —, pitted, 121, \*123  
 —, reticulate, 121, \*123

Vessels, scalariform, 121, \*123  
 —, spiral, 121, \*123  
 —, structure of, 121  
 —, walls of, 121  
 Virtual images, 28, \*29

## W

Water, absorption of, 113  
 — pores, 118  
 Wood, cell contents, 182  
 —, definition, 177  
 — fibers, 80, \*106, \*107, 108,  
   \*180, \*181.  
 —, medullary rays, 179, \*180,  
   \*181  
 — parenchyma, 178, \*181

Wood, pith, 182  
 — structures, 177, \*180, \*181  
 —, xylem elements, 178  
 Working distance, \*34, 38

## X

Xylem bundles, \*78, 80  
 — elements in woods, 178, \*180,  
   \*181  
 — fibers, 80, \*106, \*107, 108,  
   \*180, \*181

## Z

Zenker's fluid, 229  
 Zinc chloriodide solution, 229





## Wiley Special Subject Catalogues

For convenience a list of the Wiley Special Subject Catalogues, envelope size, has been printed. These are arranged in groups—each catalogue having a key symbol. (See special Subject List Below). To obtain any of these catalogues, send a postal using the key symbols of the Catalogues desired.

- 
- 1—Agriculture. Animal Husbandry. Dairying. Industrial Canning and Preserving.**
  - 2—Architecture. Building. Concrete and Masonry.**
  - 3—Business Administration and Management. Law.**  
**Industrial Processes:** Canning and Preserving; Oil and Gas Production; Paint; Printing; Sugar Manufacture; Textile.

### CHEMISTRY

- 4a** General; Analytical, Qualitative and Quantitative; Inorganic; Organic.
- 4b** Electro- and Physical; Food and Water; Industrial; Medical and Pharmaceutical; Sugar.

### CIVIL ENGINEERING

- 5a** Unclassified and Structural Engineering.
  - 5b** Materials and Mechanics of Construction, including; Cement and Concrete; Excavation and Earthwork; Foundations; Masonry.
  - 5c** Railroads; Surveying.
  - 5d** Dams; Hydraulic Engineering; Pumping and Hydraulics; Irrigation Engineering; River and Harbor Engineering; Water Supply.
- 
-

---

---

**CIVIL ENGINEERING—Continued**

**5e** Highways; Municipal Engineering; Sanitary Engineering; Water Supply. **Forestry. Horticulture, Botany and Landscape Gardening.**

**6—Design. Decoration. Drawing: General; Descriptive Geometry; Kinematics; Mechanical.**

**ELECTRICAL ENGINEERING—PHYSICS**

**7—General and Unclassified; Batteries; Central Station Practice; Distribution and Transmission; Dynamo-Electro Machinery; Electro-Chemistry and Metallurgy; Measuring Instruments and Miscellaneous Apparatus.**

**8—Astronomy. Meteorology. Explosives. Marine and Naval Engineering. Military. Miscellaneous Books.**

**MATHEMATICS**

**9—General; Algebra; Analytic and Plane Geometry; Calculus; Trigonometry; Vector Analysis.**

**MECHANICAL ENGINEERING**

**10a** General and Unclassified; Foundry Practice; Shop Practice.

**10b** Gas Power and Internal Combustion Engines; Heating and Ventilation; Refrigeration.

**10c** Machine Design and Mechanism; Power Transmission; Steam Power and Power Plants; Thermodynamics and Heat Power.

**11—Mechanics.**

**12—Medicine. Pharmacy. Medical and Pharmaceutical Chemistry. Sanitary Science and Engineering. Bacteriology and Biology.**

**MINING ENGINEERING**

**13—General; Assaying; Excavation, Earthwork, Tunneling, Etc.; Explosives; Geology; Metallurgy; Mineralogy; Prospecting; Ventilation.**

**14—Food and Water. Sanitation. Landscape Gardening. Design and Decoration. Housing, House Painting.**

---

---

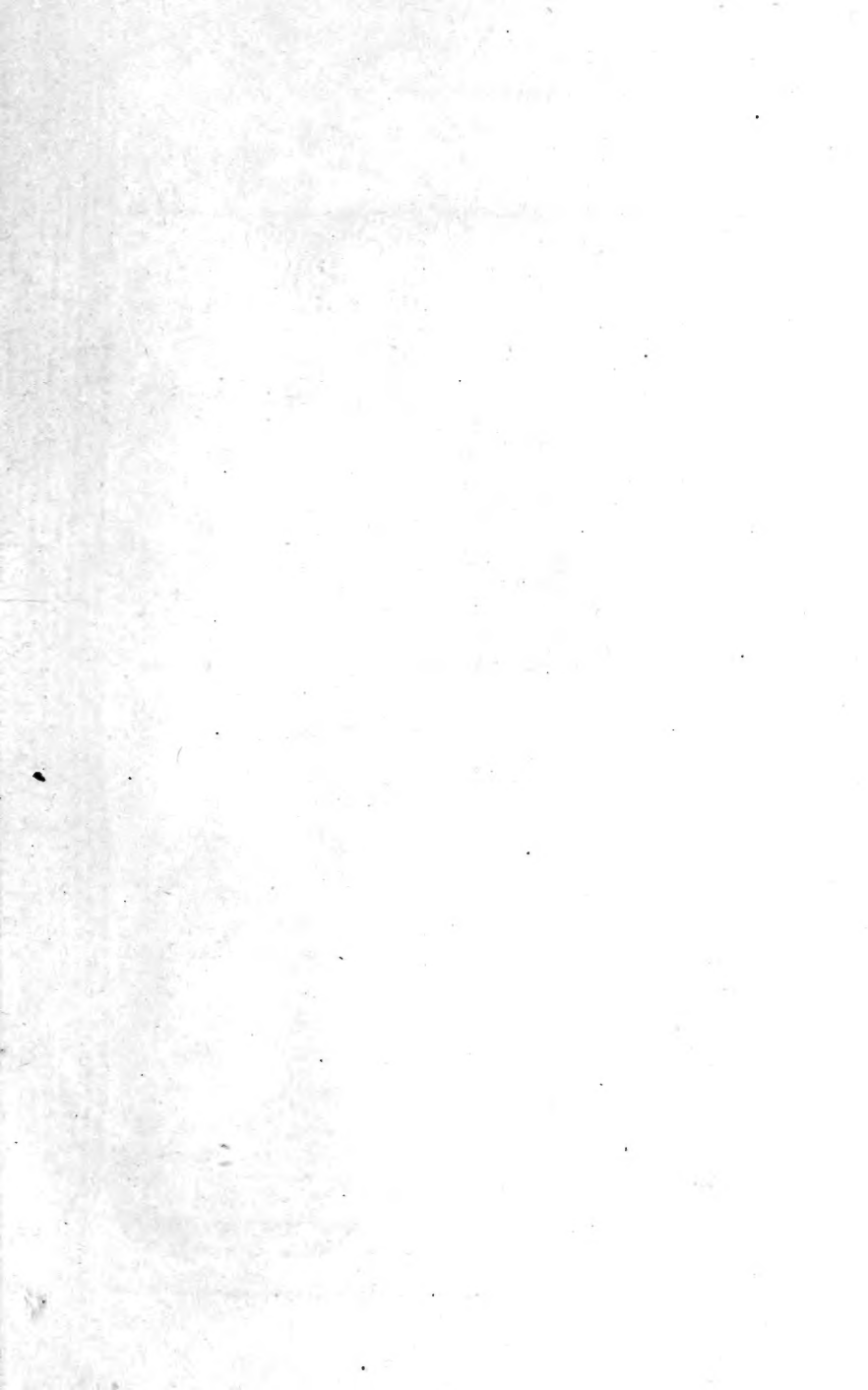

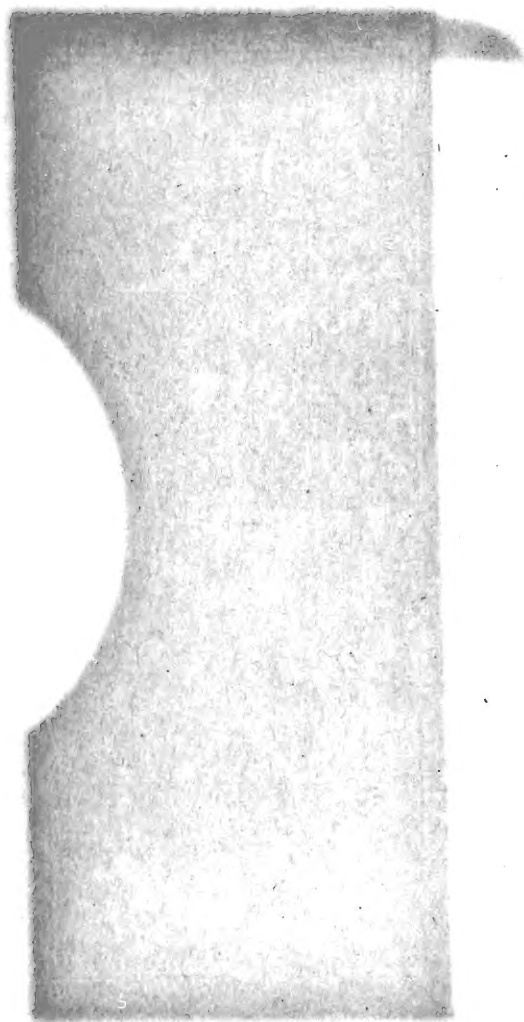

Bot.

B.

168440

Author Ballard, Charles W.

Title The Elements of vegetable histology.

University of Toronto  
Library

DO NOT  
REMOVE  
THE  
CARD  
FROM  
THIS  
POCKET

Acme Library Card Pocket  
Under Pat. "Ref. Index File"  
Made by LIBRARY BUREAU

