







# ENTOMOLOGICAL NEWS

QL  
461  
E881  
V. 72  
Ent.

VOLUME LXXII, 1961

---

PHILIP P. CALVERT, EDITOR EMERITUS

R. G. SCHMIEDER, EDITOR

## EDITORIAL STAFF

J. A. G. REHN

M. E. PHILLIPS

E. F. J. MARX

H. J. GRANT, JR.

---

PUBLISHED BY  
THE AMERICAN ENTOMOLOGICAL SOCIETY  
THE ACADEMY OF NATURAL SCIENCES  
PHILADELPHIA, PENNSYLVANIA, U. S. A.

1961

The numbers of ENTOMOLOGICAL NEWS for 1961 were mailed at the Post Office at Lancaster, Pa., as follows:

No. 1—January .....	January 12, 1961
No. 2—February .....	February 9, 1961
No. 3—March .....	March 7, 1961
No. 4—April .....	April 7, 1961
No. 5—May .....	April 27, 1961
No. 6—June .....	June 7, 1961
No. 7—July .....	July 8, 1961
No. 8—October .....	September 25, 1961
No. 9—November .....	November 1, 1961

The date of mailing the December, 1961, number will be announced on the last page of the issue for January, 1962.



15cct3

# ENTOMOLOGICAL NEWS

## JANUARY 1961

Vol. LXXII

No. 1

---

### CONTENTS

Krombein—V. S. L. Pate, 1903–1958 .....	1
Hyland and Ford—Nasal mite in the bat .....	6
Schlinger—New Acrocera and Ocnaea .....	7
Meade and Cook—Biology of <i>Scatopse fuscipes</i> .....	13
Sabrosky—New <i>Stenoscinis</i> , with key to species .....	19
Kurczewski—Records of Pepsinae and Ceropalinae .....	24
Hubbard—Specificity of kangaroo rat fleas .....	25
Notes and News in Entomology	
Fourth International Congress on social insects .....	27

---

PUBLISHED MONTHLY, EXCEPT AUGUST AND SEPTEMBER, BY  
 THE AMERICAN ENTOMOLOGICAL SOCIETY  
 PRINCE AND LEMON STS., LANCASTER, PA.  
 AND  
 1900 RACE STREET, PHILADELPHIA 3, PA.

---

Subscription, per yearly volume of ten numbers: \$5.00 domestic; \$5.30 foreign; \$5.15 Canada.  
 Second-class postage paid at Lancaster, Pa.

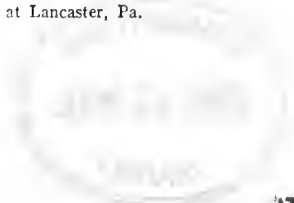

DIV. ENT.

# ENTOMOLOGICAL NEWS

---

**ENTOMOLOGICAL NEWS** is published monthly, excepting August and September, by The American Entomological Society at Prince and Lemon Sts., Lancaster, Pa., and the Academy of Natural Sciences, 1900 Race Street, Philadelphia 3, Pa., U. S. A.

**PHILIP P. CALVERT**, Editor Emeritus. **R. G. SCHMIEDER**, Editor. Editorial Staff: **H. J. GRANT, JR.**, **E. J. F. MARX**, **M. E. PHILLIPS**, and **J. A. G. REHN**.

**SUBSCRIPTIONS:** Communications and remittances to be addressed to Entomological News, 1900 Race Street, Philadelphia 3, Pa.

Prices per yearly volume of 10 numbers.

**Private subscriptions**, for personal use: in the United States, \$5.00; Canada, \$5.15; other countries, \$5.30.

**Institutional subscriptions**, for libraries, laboratories, etc.: in the United States, \$6.00; Canada, \$6.15; other countries, \$6.30.

**ADVERTISEMENTS:** Rate schedules available from the editor.

**MANUSCRIPTS** and all communications concerning same should be addressed to **R. G. Schmieder**, Zoological Laboratory, University of Pennsylvania, Philadelphia 4, Pa.

The receipt of all papers will be acknowledged and, if accepted, they will be published as soon as possible. Articles longer than eight printed pages may be published in two or more installments, unless the author is willing to pay the cost of a sufficient number of additional pages in any one issue to enable such an article to appear without division.

**ILLUSTRATIONS:** Authors will be charged as follows: For text-figures, the cost of engraving; for insert plates (on glossy stock), the cost of engraving plus printing. Size limit, when printed, 4 × 6 inches. All blocks will be sent to authors after printing.

**TABLES:** The cost of setting tables will be charged to authors.

**SEPARATA:** Members of the American Entomological Society may elect to receive, gratis, 25 offprints of their contributions. These will be "run-off-form," without removal of extraneous matter.

Those members desiring more than 25 separates, and all non-members, will receive no gratis copies. They must obtain all their separates (as reprints, with extraneous matter removed) from the printer at the prices quoted below. Authors must place their order for such separates with the editor at the time of submitting manuscripts, or when returning proof.

Copies	1-4 pp.	5-8 pp.	9-12 pp.	Covers
50	\$4.35	\$6.96	\$10.88	\$4.74
100	5.21	8.26	13.05	6.48
Add'l 100	1.74	2.60	4.33	3.48

Plates printed one side: First 50, \$3.47; Additional 100's, \$2.61.

Transportation charges will be extra.





V. S. L. PATE

# ENTOMOLOGICAL NEWS

VOL. LXXII

JANUARY, 1961

No. 1

## V. S. L. Pate, 1903–1958 \*

The recent death of Vernon Pate at Philadelphia, Pennsylvania, October 30, 1958, leaves the scientific world poorer by an extremely talented taxonomist. In a short period, 1929 to 1948, he published 92 papers. Many of these were revisions and generic reclassifications which establish him firmly as one of the world's foremost hymenopterists.

His primary interest was in the sphecoid wasps, principally in the subfamilies Nyssoninae, Pemphredoninae and Crabroninae. After obtaining his A.B. degree from Cornell University in 1928 he began an intensive study of the Oxybelini, and produced several short papers describing one new genus and several new species; two short regional papers on the oxybeline fauna of Algeria and the Philippines; and two outstanding, large papers on the Nearctic species of *Belomicrus* and *Enchemicrum* (1940). He never completed a revision of the Nearctic species of *Oxybelus*, assigned originally by J. C. Bradley as the thesis problem for his doctoral degree.

In the mid-30's Pate began publishing papers on the nyssonine-gorytine complex in the Nyssoninae and on the ammoplanoid complex in the Pemphredoninae. The most important contribution in the former series was a redefinition of the genera of Nyssonini (1938). The series on the tiny ammoplanoid wasps contained several valuable papers in which he described some new genera and a number of new species from the United States. The extent of his achievement on the ammoplanoids may be recognized when one realizes that of the currently valid taxa occurring in the United States 6 of the 9 genera and sub-

\*The accompanying portrait of V. S. L. Pate was taken by R. E. Crabill in 1951.

genera and 27 of the 32 species and subspecies were described by Pate.

In the late 30's Pate developed a great and lasting interest in the extremely difficult group, Crabroninae. He published a number of valuable papers on these wasps between 1941 and 1948. His crowning achievement and most important single contribution to taxonomy was his masterful reclassification of the genera of crabronine wasps (1943). He submitted this work to satisfy the thesis requirements for his doctoral degree at Cornell. It displays the keen analytical powers and erudition that mark all of his major taxonomic efforts. It is certain that the basic concepts of classification established in this study will endure, even though subsequent workers may describe a few genera not known to Pate.

Although the majority of his papers were on the sphecoid wasps, he published worthy generic reclassifications of the Tiphidae and Sapygidae in 1947. In addition, there were two basic nomenclatural studies that arose from his interests in wasp taxonomy. The earlier of these was a listing of the type species of genera and subgenera of the Sphecoidea, published as Memoir No. 9 of the American Entomological Society in 1937. The other was a similar listing of names applied in the Pompilidae, published in the Transactions of the same society in 1946.

Vernon had a very thorough and extensive knowledge of zoogeography and paleontology. In his more comprehensive papers he endeavored to apply knowledge from these fields in order to explain the probable evolution and distribution of a particular group of wasps. He was also a firm believer in the importance of biological characters in higher taxonomy, and many of his later papers utilize biological criteria to substantiate groupings based primarily on morphological grounds. Curiously enough, although he obviously realized the value of behavioral characters in elucidating taxonomy and gave fascinating lectures on the habits of wasps, he never published a single personal observation on wasp biology.

During the 30's he was interested in field collecting, and collected to some extent in the vicinity of Ithaca, New York, and

at Medford Lakes, New Jersey, where his family maintained a summer home. He participated with J. A. G. Rehn and J. W. H. Rehn in the Southwest Orthoptera Survey of the Academy of Natural Sciences of Philadelphia in 1937. In his early days at Cornell he was interested in limnology, and he worked for 7 summers, 1927 to 1933, for the New York State Conservation Commission on biological surveys of several of the streams and rivers in that state. In the summer of 1933 he collected insects and fossils in Kansas, Illinois, and Colorado with A. B. Klots and W. D. Sargent.

Each of us, in looking back over his own scientific career, probably can single out one teacher or colleague whose inspiration, advice and encouragement resulted in his selecting a particular field of specialization. In my own case he was Vernon Pate. His lectures in the advanced taxonomy course on the biology and taxonomy of the Hymenoptera, especially of the solitary wasps, were so stimulating and fascinating, that early in my entomological studies I decided to specialize on the same groups that engaged Pate's attention. His advice and encouragement during my undergraduate and graduate years were constant and inspiring. Other taxonomists who benefited from Pate's interest and encouragement were J. W. H. Rehn in Orthoptera, H. E. Evans in Hymenoptera, R. H. Arnett in Coleoptera, and R. E. Crabill in Myriapoda.

A generation of students will remember Pate's combined office and laboratory. One had to thread his way to the inner sanctum through a maze of insect storage cabinets and bookcases arranged as baffles. The air was blue from his chain-smoking, and cigarette ashes were dribbled liberally over the floor, tables and shirtfront of the occupant. These students also will remember the stimulating classroom and laboratory lectures that were made so vivid and meaningful by Pate's broad knowledge of biological fundamentals and his ability to relate these to the particular subject of discussion.

The honor that touched Pate most deeply was the recognition of the worth of his studies implicit in his election as a Life Member of the Academy of Natural Sciences of Philadelphia

and a Research Associate in Entomology. Writing to me from Cornell on May 4, 1938, he said: "Saturday [I] receive[d] two letters from Cadwalader the president notifying me that the Board of Trustees had a few days previously met and elected me a Life Member of the Academy and also Research Associate in Entomology. Rather took the wind out of my sails; they seem to go out of their way to be nice to me down there of late."

In his relaxed moments Pate was a delightful companion for the few who knew him well, and I recall with great nostalgia those happy golden years in the mid-30's. Pate and I would work all evening on our wasps, he in his long narrow office crammed with bookshelves and insect cabinets, I in one of the smaller labs across the hall where I shared working space with Jack Franclemont, Jack Cadbury, Derek Cross (now a physician), Verne Pechuman, Chakratong Tongyai from Siam, and, several years later, John Rehn. A frequent routine in spring and fall, after Franclemont returned from sugaring for moths and Cross came back from courting his future wife, would be a midnight visit by our quartet to the Lehigh Valley House for several rounds of beer or to Van Natta's dam for a highly refreshing swim.

Pate had a droll sense of humor that is preserved for entomological posterity in such names as *Lalapa lusa*, *Zyzzyx*, *Tea*, and *Java*. In response to my teasing him about some of the names proposed in his paper on the type species of pompilid wasps, he wrote June 7, 1947, as follows: "Furthermore I am deeply shocked that you would even consider I treat the sacred subject of nomenclature with levity. *Java* was proposed as a new name for *Dichelonyx* Haupt nec Harris, with the type *Java concolor* (Tasch.) which comes from Java. Hence the name, which is short and sweet, that is if you have any sugar these days for your coffee. *Tea* is probably an old Norse goddess or something. *Lalapa lusa* (named after the Palouse Indians of Idaho if you insist upon an etymology) is just out. And I have a n. gen. n. sp. from China which I have been wondering what to call (in the Gorytines). Will probably dedicate it to a ♀ grad student of Forbes, Da-si Pen, who has taken the Christian name



of Daisy. *Ursa dasi* would be a very nice euphonious name, don't you think?"

It is most unfortunate that progressively poorer health, possibly occasioned by the declining health and death of his parents and an increasing teaching load, resulted in his virtual retirement from active taxonomy in 1948, and his untimely death 10 years later. He left uncompleted large revisionary treatments of the *Oxybelus* of North America and of the Crabronini of North and Middle America, and several shorter manuscripts.

Vernon Sennock Lyonesse-Liancour Pate was born in Philadelphia, August 31, 1903. He received his A.B. degree from Cornell University in 1928, and his Ph.D. degree in 1946. He was a summer assistant with the New York State Conservation Commission, 1927-1933, where he worked on stream surveys particularly of aquatic insects. He was a laboratory assistant at Cornell from 1927 to 1931, and instructor in taxonomy from 1932 to 1947. He held a 6-months temporary appointment in 1945 as Associate Entomologist in the Division of Insect Identification, U. S. Department of Agriculture; during this appointment he was stationed at the U. S. National Museum where he rearranged certain sections of the wasp collection. He was appointed Assistant Professor of Entomology at Cornell in 1948, where he taught General Entomology and acted as faculty advisor for students in entomology. He was also an Associate Editor or a member of the Editorial Staff of "Entomological News" from 1936 until 1953. He resigned from Cornell in 1952, and returned to Philadelphia. He worked at the Academy as a volunteer for some months before increasingly poor health caused the abandonment of these activities.

KARL V. KROMBEIN

## The Occurrence of the Nasal Mite *Speleognathopsis bastini* Fain (Speleognathidae) from the Big Brown Bat, *Eptesicus fuscus* (Beauvois)<sup>1</sup>

By KERWIN E. HYLAND<sup>2</sup> and HEDWIG GEIGER FORD<sup>3</sup>

Fain (1958) reported on the occurrence of speleognathid mites in the nasal cavities of the bat, *Myotis myotis* (Borkh), in Belgium, and described the species as *Speleognathopsis bastini*. Earlier Fain (1955) had described *Speleognathopsis chiropteri* from the nasal cavities of several African megachiropterans (*Eidolon helvum* Kerr, *Epomophorus minor* Dobson) and *Boydaia duboisi* from a species of *Nycteris*.

A series of twenty-eight big brown bats, *Eptesicus fuscus* (Beauvois), collected on 2 August 1959, near Glen Rock, Pennsylvania, was examined for nasal mites and six bats were found to harbor a total of twelve female specimens.

These mites were compared with a paratype of *S. bastini* supplied by Alex Fain, Institut de Médecine Tropicale, Antwerp, Belgium, and are considered to represent this species in North America. Furthermore, this represents the first record of speleognathids occurring in the nasal cavities of bats on this continent.

Determined specimens have been deposited in the following collections: United States National Museum, Washington, D. C.; the Institute of Acarology, University of Maryland, College Park; and Institut de Médecine Tropicale, Antwerp, Belgium.

### LITERATURE CITED

- FAIN, ALEX. 1955. Sur le parasitisme des fosses nasales chez les mammifères et les oiseaux par les acariens de la famille Speleognathidae (Acarina). Description d'une espèce nouvelle chez la chauve-souris. Ann. Soc. Belge Med. Trop. 35(6): 692-694.
- . 1958. Un nouveau speleognathe (Acarina—Ereynetidae) parasitant les fosses nasales du murin (*Myotis myotis* (Borkh)) en Belgique: *Speleognathopsis bastini* n. sp. Bull. Ann. Soc. Roy. Ent. Belge 94: 342-345.

<sup>1</sup> Contribution No. 106 from the Kellogg Gull Lake Biological Station, Hickory Corners, Michigan, U. S. A.

<sup>2</sup> Department of Zoology, University of Rhode Island, Kingston.

<sup>3</sup> Kellogg Gull Lake Biological Station, Hickory corners, Michigan.

## New Species of Acrocera from Arizona and Ocnaea from California, with Synonymical Notes on the Genus Ocnaea (Diptera: Acroceridae)

By EVERT I. SCHLINGER,<sup>1</sup> University of California Citrus Experiment Station, Riverside

This is one of a series of articles dealing with revisions, reviews or new species of acrocerid flies which have been prepared as a prerequisite to a generic revision of the family Acroceridae. A recent article of the series (Schlinger, 1960) cited references to most of the previous papers. Two new species of Acroceridae are described separately at this time in order to make their names available for inclusion in another concurrent work.

### SUBFAMILY PANOPINAE

#### Genus OCNAEA Erichson

*Ocnaca* Erichson, 1840, Entomographien, 1: 155.

*Pialcoidea* Westwood, 1876, Trans. Ent. Soc. Lond., p. 514 (type species, *Cyrtus magnus* Walker). NEW SYNONYMY.

The genus *Pialcoidea* was described by Westwood as a close relative of *Pialca* Erichson, but such is not the case (Schlinger, 1956). In fact, *Pialcoidea* species have been distinguished from *Ocnaca* species only on the basis of a female sex character, i.e., a group of apical setae on the terminal antennal segment. An examination of several female specimens of *Ocnaca helluo* Osten Sacken and *O. loewi* Cole has shown these specimens to contain the apical setae that characterize *Pialcoidea* species. Males of species in both genera are described as lacking the apical setae. Being unable to find other differentiating features between the two genera, I place *Pialcoidea* in synonymy with *Ocnaca*.

*Ocnaca* is a New World genus which comprises 20 species. To this number are now added the following five species: *Pialcoidea brasiliensis* Carrera, *P. gloriosa* Sabrosky, *P. metal-*

<sup>1</sup> The author would like to thank Dr. A. L. Melander of Riverside, California, for the loan of the type series of *Acrocera melanogaster*, new species.

*lica* Osten Sacken, *Cyrtus magnus* Walker, and *Ocnaea xuthogaster*, new species.

***Ocnaea xuthogaster* new species (figs. 1-3).**

*Male.* Length of entire specimen 7 mm., wing length 5 mm.

*Color* black, yellow, and brown with some metallic blue reflections; black are eyes, occiput, ocellar tubercle, mesonotum, scutellum, most of pleura and tarsal claws; dark brown are antennae, antennal tubercle, ocelli, humerus and postalar callus (almost black), coxae, basal one-half of femur I, most of femora II and III, basal one-half of tibia III, apices of distitarsi, halter knob, costa, subcosta and  $R_1$  wing veins, tergite I, large median spot on each of tergites II to VI, and most of genitalia; light brown are remainder of legs, remainder of wing veins, squamal rim, and small lateral spot on each of sternites III to V; yellow are remainder of abdomen and halter stem; metallic blue reflections are present in certain views of light on mesonotum, scutellum, upper pleura, and on all dark brown median tergal spots.

*Pile* light brown and dense on eyes and occiput, reaching out a little beyond tip of antennal segment I; that on thorax, coxae, squama, and abdomen yellowish white and dense, about as long as length of distitarsus III except more sparse and much shorter on abdominal sternites; that on legs yellowish white, short, dense, and appressed except longer and erect on base of femora and on trochanters; that on apices of distitarsi dark brown, about as long as a pulvillus; short light brown hairs are present on basal one-third of costal vein.

*Head* (fig. 1) nearly one and one-half times higher than long; antenna about one and one-fourth times longer than head height, segment III laterally compressed; antennae asetate except for short group of setae on dorsum of segment II; ocellar tubercle with slightly raised lateral ocellus; antennal tubercle small, barely produced above antennae; proboscis not evident, but minute proboscis covering present; eyes narrowly separated from antennae to frons.

*Thorax* shiny, but difficult to detect under its dense pile; each leg with distinct tibial spur, that on hind tibia about as long as

the length of antennal segment I; coxae subequal in length, but femur and tibia of leg III longer than those of leg II, and those of leg II longer than those of leg I; femur III nearly one and one-half times longer than femur I; squama nearly opaque; wing venation as in fig. 2; wing membrane transparent but distinctly creased and appearing somewhat smoky; scutellum almost twice as wide as long.

*Abdomen* shiny, quite narrow, widest at segment III; median spots on each of tergites II to V half-moon-shaped, those on II to IV broadly attached anteriorly, not quite reaching posterior margin of each segment and each spot separated from latero-anterior margin by distance equal to about one-fourth the width of each tergite; spot on tergite V similar in shape to that on IV except it is more broadly attached anteriorly and spot reaches out mediolaterally to touch lateral margin; spiracle I is in tergite I while other spiracles appear to be placed in intersegmental membrane; genitalia strong, aedeagus formed as in fig. 3.

*Female* unknown.

*Holotype male.* Benton Station, Mono County, CALIFORNIA, July 20, 1950 (H. A. Hunt), collected on window inside of house. The type locality is very close to Nevada at an elevation of about 6,500 feet. The holotype will be deposited in the California Academy of Sciences Collection in San Francisco, California.

This species is closely related to *O. sequoia* Sabrosky and somewhat less related to *O. helluo* Osten Sacken. It can be separated from both species by the male genitalia and wing venation. *O. xuthogaster* is also distinguished from *O. helluo* by its dark brown humeri, metallic blue reflections and yellow abdominal sternites, and from *O. sequoia* by its dark brown humeri and yellow sternites.

The specific name *xuthogaster* refers to the yellow abdomen.

#### SUBFAMILY ACROCERINAE

#### Genus **ACROCERA** Meigen

*Acrocera* Meigen, 1803, Illigers Mag. Ins., 2: 266.

This genus is cosmopolitan in distribution except for Australia and New Zealand, and contains about 45 valid species. The addition of the new species described below brings the total number of North American species to 17.

**Acrocera melanogaster** new species (figs. 4-7).

This species is a member of species group I as outlined by Sabrosky (1944). Species of this group are characterized by having vein  $R_{2+3}$  complete.

*Male.* Length of entire specimen 3.5 mm., wing length 3.5 mm.

*Color* black, brown, and pale yellow; black are eyes, occiput, ocellar tubercle, antennal segment I, frons, mesonotum, scutellum, metanotum, most of postalar callus, tarsal claws, and all abdominal tergites; dark brown are remainder of antennae, minute proboscis, ocelli, pleura, outer upper edge of postalar callus, coxae, apical half of distitarsi, wing veins, most abdominal sternites, and genitalia; pale yellowish brown are humerus, spiracular area immediately below humerus, small area below wing base, remainder of legs, faint posterior fascia on sternites II and III, halter knob and stem.

*Pile* white, very short over entire body.

*Wing* hyaline, venation strong, vein  $R_{2+3}$  complete (fig. 6); squama hyaline, densely covered with minute hairs; squamal rim narrow; abdominal tergite II flared out posterolaterally, somewhat inflexed anterolaterally; abdomen widest at segment III; tergite V somewhat emarginate medially; male genitalia as in figs. 4 and 5.

*Abdomen and thorax* are quite shiny.

*Female.* Same as male except pale yellowish brown areas are more yellowish white; area around prothoracic spiracle and intersclerotic area extending from spiracle to wing base is bone white; female genitalia (fig. 7) have extremely long cerci.

*Paratype variation.* Lengths of entire specimens range from 2.5 to 4 mm., wing lengths range from 2.25 to 3.75 mm. Some of the males have tergites IV and V very dark brown instead of black, have narrow whitish yellow posterior fascia on ster-

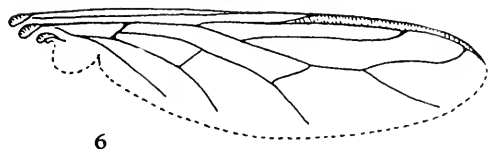
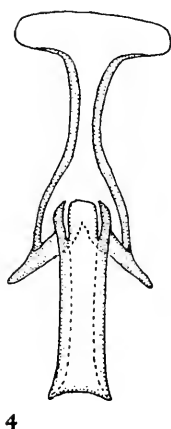
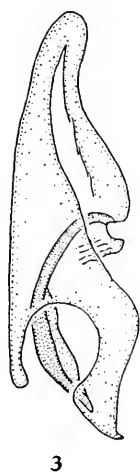
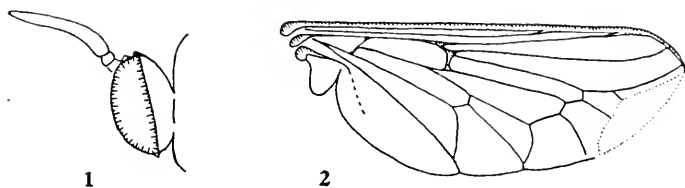

## EXPLANATION OF FIGURES

Figs. 1 to 3, *Ocnaca xuthogaster* new species; figs. 4 to 7, *Acrocera melanogaster* new species. Fig. 1, head in lateral view; figs. 2 and 6, wings; fig. 3, aedeagus in lateral view; fig. 4, aedeagus in ventral view; fig. 5, aedeagus in lateral view; fig. 7, female caudal abdominal segments and cerci in lateral view.

nites II and III, and have their genitalia lighter brown. No differences were seen between the two female specimens.

*Holotype male.* Globe, ARIZONA, October 9, 1935 (F. H. Parker).

*Paratopotypes.* 10 ♂♂, all collected on October 9, 1935, except 1 ♂, May 25, 1936, and 2 ♀♀, June 9, 1935 (all F. H. Parker).

The holotype will be deposited in the California Academy of Sciences Collection in San Francisco, California, and the paratopotypes will be placed in the collections of Axel L. Melander, United States National Museum, and the author.

According to Dr. Melander, the collector gathered all the male specimens on October 9, 1935, from a water pipe under the collector's house. It is also of interest to note that males were collected from May to October at the type locality, showing quite a range of occurrence in time.

This species is related to both *Acrocera arizonensis* Cole and *A. bakeri* Coquillett. It is most similar to *A. arizonensis* and will key out with *A. arizonensis* at couplet 5 of Sabrosky's key to the North American species of *Acrocera* (1948). It is separated from *A. arizonensis* by having all its abdominal tergites black instead of with only black spots, and in having most of the abdominal sternum dark brown instead of yellow.

The specific name *melanogaster* refers to the shiny black abdomen.

#### REFERENCES CITED

- SABROSKY, C. W. 1944. A revision of the American spider parasites of the genera *Ogcodes* and *Acrocera* (Diptera, Acroceridae). Amer. Mid. Nat. 31: 385-413, figs. 1-8.
- . 1948. A further contribution to the classification of the North American spider parasites of the family Acroceratidae (Diptera). Amer. Mid. Nat. 39: 382-420, figs. 1-22.
- SCHLINGER, E. I. 1956. A revision of the acrocerid flies of the genus *Pialea* Erichson with a discussion of their sexual dimorphism (Diptera). Proc. U. S. Nat. Mus. 106: 359-375, figs. 1-4.
- . 1960. A review of the South African Acroceridae (Diptera). Ann. Natal Museum 14: 459-504, figs. 1-29.



## Notes on the Biology of *Scatopse fuscipes* (Meigen) (Diptera: Scatopsidae)

By ALSTON B. MEADE and EDWIN F. COOK<sup>1</sup>

### INTRODUCTION

The scatopsids are a small, economically unimportant family of Diptera. One species (*Scatopse fuscipes*) is occasionally a nuisance around canneries and wineries since it can develop large populations in very small amounts of decaying organic matter. This insect is easily reared under laboratory conditions. This quality, in addition to its relatively short life cycle, makes it ideal as a potential subject for ecological studies. An exhaustive search of the literature revealed that very little information is available on the biology of any of the scatopsids. This work is undertaken with the hope of supplying some of this basic knowledge, which will facilitate more extensive investigations.

### MATERIALS

The flies used in these experiments were from a culture reared in the laboratory for 3 years. They were fed on CSMA fly medium,<sup>2</sup> saturated with water, and allowed to ferment for 12 hours. The medium is placed in petri dishes or in 1 pint wide-mouthed jars in the fly cage, and kept quite moist. New medium is introduced as needed. Except when otherwise specified, the flies were reared at room temperatures and not under any precisely controlled conditions. Room temperatures in the laboratory varied from 75° to 80° F. with little or no variation between night and day temperatures. The cages used were 18" × 12" × 10", of wood construction with a glass top, and with two small, sleeved openings for ready access.

<sup>1</sup> Paper No. 4406 Scientific Journal Series, Minnesota Agricultural Experiment Station, St. Paul 1, Minnesota.

<sup>2</sup> The medium used here is the dry mixture prepared by the Ralston-Purina Company, St. Louis, Missouri and consists of 2 parts of soft wheat bran (coarse) and one part of alfalfa meal.

## ADULTS

*Mating behavior.* The flies appear to be sexually mature on emergence, since copulation sometimes occurs when the adults are only 30 minutes old. Large numbers of mating pairs may be seen concentrated under petri dishes and in the corners of the cages. This concentration may be due to a negative response to light or to positive thigmotropism. Adults copulate for considerable periods and separate for varying periods, sometimes changing mates. An adult, presumably male, may try to separate a copulating pair presumably with a view to finding a mate. The adult stage seems to be devoted exclusively to reproduction and food is not consumed. If provided with a moist substrate, most females will oviposit.

*Oviposition.* Female *S. fucipes* oviposit 24 to 30 hours after emergence, and die shortly after oviposition. Most males live 30 to 45 hours.

*Oviposition site.* The following tests were made to determine the suitability of various sites for oviposition. A number of copulating pairs of flies were placed in two sets of three petri dishes each, one containing food resting on moist filter paper, another with moist filter paper and no food, and the third with only dry filter paper. After a few days, the dishes were carefully examined. The results (Table 1) show that the flies do not oviposit on dry surfaces. Eggs were found in all dishes except those containing dry filter paper. Some females from the latter group had strands of up to 30 eggs protruding from the genitalia. This suggests that, in the absence of moisture, oviposition may be initiated but cannot be completed. Dark areas, e.g., spots, or bits of food on filter paper, were always preferred sites for egg-laying.

TABLE 1.—Comparison of Several Sites for Oviposition

	Egg Masses	Females having Oviposited	Females still Gravid
Food	11*	12	1
Dry paper	0	0	12
Moist paper	8*	9	3

\* Eggs laid by 1 female were apparently concealed and could not be found.

*The egg mass.* The eggs are released from the female in a long strand, each egg being attached at the ends to the preceding and succeeding ones, and this strand is folded lengthwise into a mass. The mass does not lie flat on the substrate, but is somewhat crescent shaped, so that the eggs appear to be pointed upwards. The eggs are arranged in rows, about six rows constituting the length of the mass. Ten egg masses were measured and the lengths ranged from 1.2 to 1.7 mm. and averaged 1.3 mm. The widest part of an egg mass occurs in the middle, while the ends taper gently. The width consists of about six eggs lying side by side. Shortly after oviposition the apical attachments of the eggs are broken. Occasionally an incomplete egg mass is seen, in which the eggs spread over a wider area, and are irregularly arranged.

*The oviposition process.* A gravid fly was placed on its back on moist filter paper and its abdomen pressed gently for a few seconds. Observation under a binocular microscope showed peristaltic movements in the segments close to the genitalia, and at each contraction an egg was released. The eggs came out in a long strand which soon formed a cluster. After about fifty eggs had been released, the rate of contraction was timed. For the next four minutes, the rate of contraction was 29, 28, 27, and 26 per minute, respectively. During the fifth minute the release of eggs ceased, but peristalsis continued for two minutes longer, the rate decreasing rapidly. The fly remained inactive and died after 90 minutes. On dissection, seven eggs were found in the ovary. Subsequent attempts to induce oviposition in other females were not successful.

### Eggs

The eggs in the mass may be separated by placing them in 1% sodium hypochlorite. In a few minutes, complete separation is achieved and they may be easily counted. On January 10, five egg masses were counted. The number of eggs per mass ranged from 135 to 215, with an average of 189. On March 28, ten egg masses produced an average of 257 eggs per mass and ranged from 174 to 320. The difference in the egg production

of the two groups may have resulted from differences in food consumption during the larval stages.

*Effect of temperature on incubation of eggs.* The effect of temperature on incubation was studied by placing egg masses in hanging drops and exposing them to different temperatures until hatching. The results (Table 2) show that the lower threshold for hatching lies between 5° and 10° C. At the former temperature, no hatching occurred, while at the latter, hatching occurred in 16 days. Between 10° and 30° C., there was an inverse relationship between temperature and incubation period. At the temperatures: 10°, 15°, 20°, 25°, 30°, and 35° C. eggs hatched in 16 days, 189–206 hours, 120 hours, 72 hours, 47 hours, and 45–49 hours, respectively. The test failed to show any appreciable difference in hatching time at 30° and 35° C. We may reasonably assume that the upper threshold for hatching is a little above 35° C.

TABLE 2.—Effect of Temperature on Incubation of Eggs

Temperature	Rep. 1	Rep. 2	Rep. 3
5° C.	—*	—*	
10° C.	16 days		
15° C.	189–206 hrs.	189–206 hrs.	
20° C.	120 hrs.	126½ hrs.	
25° C.	72 hrs.	76–79 hrs.	72 hrs.
30° C.	47 hrs.	42–54 hrs.	
35° C.	41–49 hrs.	45½–49½ hrs.	

\* No hatching occurred.

#### LARVAE

*Duration of larval stage.* One egg mass was placed in each of four dishes supplied with large amounts of CSMA fly medium. The duration from the hatching of eggs to pupation was noted. The data (Table 3) show that in the first dish the larval stage lasted from 12 to 15 days, in the second dish from 11 to 15 days, in the third dish, from 12 to 14 days, and in the fourth dish from 13 to 18 days.

*Effect of inadequate food supply on larval growth.* Egg masses were placed in four dishes which contained very limited

amounts of food. The eggs hatched on schedule, but during the next 49 days no pupae appeared in any of the dishes. Three dishes were then discarded and the fourth observed closely for an additional four months. Still no pupae had appeared, although the larvae remained active. Thus the larval period was extended to nearly seven months.

To determine whether food shortage accounted for the failure of the insects to pupate, the larvae from one of the discarded dishes were transferred to a chamber with adequate food. Four days later the first pupa was formed. Within 17 days, 49 insects had completed the larval stage. These findings indicate that the scatopsid larvae had a tremendous ability to withstand adverse conditions. Poor food supply can seriously retard larval growth, but can also prolong larval life.

*Number of larval instars.* The number of larval instars may be determined by counting the number of larval skins shed by an insect. In this experiment, the food medium was allowed to ferment, then it was filtered. Newly emerged larvae were reared on the filtrate and the number of molts recorded. Of the 23 insects which completed the larval stages, 17 underwent three molts each, while each of the remaining six were observed to molt twice. It is believed that on each of these six occasions, one molt was overlooked. Hence, we may conclude that the Scatopsid has four larval instars.

TABLE 3.—Duration of Larval Stage

Days after Hatching	Number of Pupae Appearing			
	Rep. 1	Rep. 2	Rep. 3	Rep. 4
11		6		
12	13	15	3	
13	8	11	2	7
14	3	5	1	6
15	1	2		12
16				28
17				7
18				5

## PUPA

*Duration of pupal stage.* Pupae were placed on moist filter paper in vials, as soon as they were formed. Notes were made of the time required to complete the pupal stage. Three tests were conducted on different dates. In each test, the adult females emerged earlier than the males. However, the results for any given sex varied from one test to another. This is probably due to differences in room temperature at the time when the different experiments were performed. The duration of the pupal stage in 14 males ranged from 96 to 139 hours with a mean of 109.4 hours, while that of 11 females ranged from 86 to 126 hours with a mean of 97.6 hours.

## ABSTRACT

The life cycle of *Scatopse fuscipes* is completed in about 20½ days at room temperature. The approximate duration of the egg, larval, pupal, and adult stages are 3, 12, 4, and 1½ days, respectively. The females have shorter adult and pupal stages than the males. Within certain limits there is an inverse relationship between temperature and the incubation period of eggs. The larval stage may be prolonged if food supply is inadequate. Larvae have been known to survive for nearly 7 months under these adverse conditions. There are probably 4 instars.

Adults copulate as early as ½ hour after emergence from the pupae, and oviposit in 24 to 30 hours. Death occurs shortly after eggs are laid. Oviposition may be initiated in the absence of moisture, but cannot be completed under those conditions. Eggs are released by the female in a long strand which is folded into a cluster. The number of eggs laid by individual females ranges from 172 to 320.

Adults react negatively to light.

## A New Nearctic Species of *Stenoscinis*, with Key to the Species of the Western Hemisphere (Diptera, Chloropidae)

By CURTIS W. SABROSKY, Entomology Research Division,  
U. S. Department of Agriculture

The genus *Stenoscinis* was erected by Malloch in 1918 for the single species *Oscinis longipes* Loew, and *Oscinis atriceps* Loew was added later. A third and very distinctive species has recently been discovered in southern Arizona. I take pleasure in naming it for the collector and enthusiastic student of Diptera, Marian Adachi Kohn, who has furnished a drawing of the species (fig. 1).

Species of *Stenoscinis* are known in the Nearctic, Neotropical, and Ethiopian regions, those in the Nearctic apparently being Neotropical derivatives. The species from Arizona here described is most closely related to *S. major* (Duda), known from Costa Rica and Guatemala. Because of the new species and the reassignment of others, discussed below, I present a key to seven species, including the five that I recognize in *Stenoscinis* in the western hemisphere, and two in the related genus *Rhopalopterum*.

In 1929 (Konowia 8: 165-169), Duda published a short paper on the Chloropidae of the German Chaco-Expedition in which there appeared a new generic name *Rhopalopterum* (p. 167) associated with a known species, *Oscinella limitata* Becker and a new variety of it. The following year, in his revision of the Neotropical Chloropidae (1930, Folia Zool. Hydrobiol. 2: 107) that was probably expected to appear before the Chaco report, Duda proposed a new genus *Rhopalopterum* for *limitatum* (Becker) and *infumatum* (Becker). The difference in spelling is slight, and the two generic names certainly refer to the same genus. In 1931 (Folia Zool. Hydrobiol. 3: 166), Duda designated *limitatum* as the type-species of *Rhopalopterum*. In 1934, he added three new species, and gave a key to the known species (Konowia 13: 58-69, 101-110).

For some time I considered *Rhopalopterus* as a synonym of *Stenoscinis*. However, it may be that the former can be maintained for *limitatum* and *flavicornis* Duda (1934). These species are characterized by a more developed anal region of the wing; short, *Oscinella*-like discal cell; 1 + 1 strong notopleural bristles; and short, apically subtruncate scutellum with widely separated apical scutellar bristles set on small tubercles. Of the four remaining species included by Duda, *R. majus* Duda and *R. antiguense* Duda are here referred to *Stenoscinis* (new combinations), and *R. infumatum* (Becker) is actually a *Lasiopleura*. I have not seen the type of *R. limitatum* var. *glabrum* Duda, but it may not belong. A specimen from Alhajuelo, Panama, March 4, 1912 (A. Busck) [U. S. National Museum], determined by Duda as *glabrum*, is *Monochactoscinella anonyma* (Williston).

In 1936, in reviewing the Nearctic species of *Oscinella* and *Madisa* (Ent. Soc. Amer. Ann. 29: 707-728), I synonymized *Stenoscinis* with *Oscinoides* Malloch, an entirely erroneous association as I soon realized and later noted in print (1951, Ruwenzori Expedition, 1934-5, British Museum (Natural History), vol. 2, no. 7, pp. 808-809).

#### KEY TO SPECIES OF STENOSCINIS OF WESTERN HEMISPHERE

1. Frontal triangle large, broad to apex, projecting shelflike above bases of antennae; occiput strongly developed, viewed from above  $\frac{1}{3}$  length of eye, subtruncate; ocellar bristles proclinate and divergent; large species, 3-4 mm. . . . . 2  
     Frontal triangle not so, ending at or near anterior margin of front, the apex acute or only slightly broadened; occiput not strongly developed; smaller species, 1.5-2 mm. . . . . 3
2. Cheek linear; front only slightly projecting; fore coxae and all femora except apex of third, yellow; one row of hairs along each side of frontal triangle (Costa Rica, Guatemala) . . . . . **S. major** (Duda), n. comb.  
     Cheek broader, one fourth height of eye; front strongly projecting, over half length of eye in front of eye; fore coxae and all femora except knees narrowly, black; two rows of hairs along each side of triangle (Arizona) . . . . .  
     . . . . . **S. adachiae**, new species



3. Second costal sector obviously shorter than third sector (0.75); ocellar bristles erect and cruciate (Neotropical) . . .  
**Rhopalopterum limitatum** (Becker), **R. flavicorne** Duda  
 Second costal sector equal to or obviously longer than third sector . . . . . 4
4. Ocellar bristles erect and convergent to tips or cruciate; second costal sector obviously longer than third sector; mesonotum shining . . . . . 5  
 Ocellar bristles proclinate and divergent; second and third costal sectors equal; mesonotum usually with broad median stripes of fine gray tomentum (United States) . . . . .  
 . . . . . **S. longipes** (Loew)
5. Legs entirely yellow; frontal triangle ending acutely well short of anterior margin of front (e. United States, se. Canada) . . . . . **S. atriceps** (Loew)  
 Legs black except for trochanters and knees; frontal triangle extends to anterior margin of front, ending bluntly (Guatemala) . . . . . **S. antiguensis** (Duda), n. comb.

#### STENOSCINIS Malloch

*Stenoscinis* Malloch, 1918, Brooklyn Ent. Soc. Bul. 13: 21.  
 Type species, *Oscinis longipes* Loew, by original designation and monotypy.

The slender, elongate form of body, legs, and wings, with the reduced anal area of the wing, distinguishes this group from *Oscinella* and related genera of the Oscinellinae. Typically, the eye is large and the cheek linear and inconspicuous. The type-species has the ocellar bristles proclinate and divergent, a character not common in the Oscinellinae, and this character is indeed found in a number of species referred to the genus. However, in a few species that represent a transition from *Oscinella* and related genera, the ocellars are convergent to tips or cruciate. Otherwise they have the typical structure of *Stenoscinis*, and I have referred them to the genus (see discussion by Sabrosky 1951, op. cit. pp. 808-809).

Typically, *Stenoscinis longipes* has a broad median stripe of pollinosity or fine tomentum on the mesonotum. In a few specimens, this is reduced to a prescutellar band, leaving the mesonotum more highly shining. The male genitalia of the shining and pollinose forms are the same, however, and for the present at least I consider the shining form only a variant.

**Stenoscinis adachiae**, new species (Fig. 1)

Head elongate; frontal triangle broad throughout and occupying most of front; cheek distinct.

Male, female.—Black, only the halteres, trochanters, knees, fore and mid tibiae, basal two-fifths of hind tibiae, most of fore basitarsi, and the two proximal segments of mid and hind tarsi, yellow; veins and wing membrane brown, both yellowish on basal fourth of wing; hairs chiefly whitish yellow; bristles chiefly yellow, the apical scutellars black.

Head (fig. 1) broader than thorax, and almost as broad as long, but appearing elongate, front projecting over half the length of an eye in front of the eyes, occiput extending one-third the length of an eye behind them and subtruncate in dorsal aspect, hind margin of head nearly straight; eyes with sparse, microscopic pubescence; front broad, nearly three times the width of an eye; frontal triangle large, occupying most of front, narrowly separated from eyes and of nearly equal width throughout, only slightly tapered and ending broadly anteriorly, extending shelflike over the antennal bases; surface of triangle smooth and polished, with two rows of piliferous punctures along each side, one on the very edge; head in profile almost 1.5 times as long as high, face extremely oblique because of projecting front, and the vibrissal angle obtuse; long axis of eye diagonal; cheek narrow, one-fourth the height of an eye and one-fifth the height of head; face narrow, polished, with sharp facial carina and deep antennal grooves; median clypeal plate large, polished, appearing continuous with face; oral opening small, mouthparts likewise. Antennae with third segment as long as broad, but not completely orbicular; arista pubescent. Chaetotaxy of head weakly developed, only the outer vertical bristles strong, the proclinate and divergent ocellars and the postverticals but little stronger and longer than frontal hairs.

Mesonotum narrow, 1.24 times as long as broad, with numerous strong piliferous punctures; thorax shining, with gray tomentum only on notopleuron, narrowly above base of wing, posterodorsal corner of mesopleuron and anterodorsal corner of pteropleuron, squamopleuron, narrow prescutellar area, and scu-

tellum; latter relatively large, broadly rounded apically, evenly convex without distinct margins, the median area slightly rugose and with numerous hairs. Chaetotaxy: 1 + 2 notopleural, 1 postalar, 1 subapical and 1 apical scutellar pairs of bristles, only the lower posterior notopleural, postalar and apical scutellars strong; apical scutellars well separated, the subapicals close to apicals but weak and scarcely distinguishable from hairs.

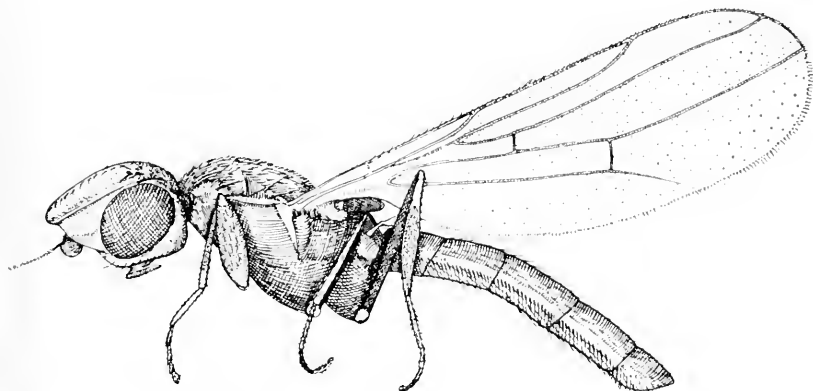

FIG. 1. *Stenoscinis adachiae*, n. sp. Side view, the head turned slightly to show the large frontal triangle.

Abdomen slender and elongate, narrower than thorax and nearly twice as long.

Legs relatively slender and elongate, the hind legs especially so; "sensory area" on hind tibia narrow, barely over one-fourth the length of tibia.

Wing as figured (fig. 1), the second costal sector only slightly longer than third sector, first posterior cell broadening distally, fore crossvein beyond middle of discal cell, and anal region of wing narrow.

Length of body and wing, 3.5 mm. (male), 4 mm. (female).

*Holotype*, male, *allotype*, and one *paratype* (male), Catalina Mts., ARIZONA (Milepost 10, Hitchcock Highway), Aug. 13, 1958 (M. Adachi). Type No. 65458 in the U. S. National Museum.

## New North American Records of Pepsinae and Ceropalinae (Hymenoptera: Pompilidae)

By FRANK E. KURCZEWSKI, Allegheny College,  
Meadville, Pennsylvania<sup>1</sup>

The records presented below are based upon two summers' collecting in Erie and Crawford Counties, Pennsylvania. The majority of specimens were captured on flowers while a few were taken nesting.

This list is presented with hopes of filling in existing gaps in the western Pennsylvania collecting records. The record for *Ageniella fulgifrons* is believed to be the most northern in northeastern United States while that for *Chirodamus fortis* is believed to be the most northern, definite record of its range in North America. There has been one collection of *C. fortis* labelled vaguely "NY" (Leonard, M. D. 1926. A List of the Insects of New York, Ithaca, N. Y.).

### Subfamily Pepsinae

*Chirodamus fortis* (Cresson). Crawford Co., Cambridge Springs, June 29, 1 male on *Pastinaca sativa*. Frenchtown, July 3, 1 male on Salicaceae.

*Priocnemioides unifasciatus unifasciatus* (Say). Erie Co., Erie, July 22–August 8, 3 males and 2 females on *Daucus carota*.

*Priocnemis minorata* Banks. Crawford Co., Blooming Valley, May 3, 1 female under dead leaves on forest floor, 1 male as it alighted on violet leaf. Frenchtown, May 4–May 8, 1 female under dead leaves on forest floor, 1 female from moist mud near water puddle, 1 male on dead leaves near stream, 1 male in flight.

*Priocnemis cornica* (Say). Crawford Co., Meadville, September 30, 2 females on gravelly, sunny bank dragging small Lycosidae, probably *Pardosa sp.*, backwards.

<sup>1</sup> Present address: Department of Entomology, Cornell University, Ithaca, New York.

I should like to express my appreciation to Dr. R. E. Bugbee, Allegheny College, for his encouragement and for reading the manuscript and to Dr. Howard E. Evans, Cornell University, for checking the identities of the species involved and for advice regarding the latest taxonomic reviews on the subject.

- Calicurgus hyalinatus alienatus* (Smith). Crawford Co., Meadville, June 23, 1 female on outside of window. Cambridge Springs, June 29, 1 female on *Pastinaca sativa*.
- Dipogon sayi sayi* Banks. Erie Co., Presque Isle State Park, June 8, 1 female running over trunks of freshly-cut trees.
- Phanagenia bombycina* (Cresson). Crawford Co., Meadville, October 30?, 1 female, no other data (L. M. Byers, collector).
- Auplopus architectus architectus* (Say). Crawford Co., Meadville, May 19, 1 female as it alighted on ivy leaf.
- Auplopus nigrellus?* (Banks). Crawford Co., Meadville, October 6, 1 female, no other data (L. W. Byers, collector).
- Ageniella fulgifrons* (Cresson). Erie Co., Erie, July 25, 1 female on *Daucus carota*.

#### Subfamily Ceropalinae

- Ceropales maculata fraterna* Smith. Erie Co., Erie, August 16, 1 male on *Daucus carota*. Crawford Co., Cambridge Springs, June 29, 1 female on *Pastinaca sativa*.
- Ceropales bipunctata bipunctata* Say. Crawford Co., Meadville, August 20, 1 male on *Solidago sp.*

---

### Host Specificity of Fleas from Kangaroo Rats

By C. ANDRESEN HUBBARD, Tigard 23, Oregon

With the exception of the siphonapterist few naturalists recognize the specificity of a flea to its natural host. While working the fleas of the kangaroo rats of northern California these last few months the writer made his way into Surprise Valley in extreme northeastern Modoc county. The Valley, a few miles more than 60 long and at no point more than a stone's throw west of Nevada, has on its floor three dry lakes (alkali flats most of the year) named, of course, Upper, Middle, and Lower Lake. To the west are the high Warner Mountains, to the east what natives call the Nevada Hills. Cedarville, the chief town in the valley, is at the north end of Middle Lake and farther north by 25 miles is Fort Bidwell at the north end of Upper Lake. There is no natural barrier of any type between the towns.

During mid October 1960 the writer trapped 9 kangaroo rats east of Cedarville in the sand beyond the bed of Middle Lake, and a like number of them 4 miles east and north of Fort Bidwell. About 2 dozen fleas were removed from each batch.

Several days later in his laboratory, with the kangaroo rats still quite alive and comfortable, the writer processed the fleas and found that the Cedarville specimens were carrying only *Meringis dipodomys*, and that the Fort Bidwell specimens carried only *Meringis cummingi*, the former the flea of the kangaroo rat *Dipodomys microps*, the latter the flea of the kangaroo rat *Dipodomys hermanni*. But all mammalian records said Surprise Valley housed only *Dipodomys microps*. Had the fleas made a mistake? The writer hardly thought so, and therefore, even though the 18 kangaroo rats from Surprise Valley all looked alike, they were destined to be shipped alive to Dr. Murray Johnson, surgeon of Tacoma, Washington, working at the University of Puget Sound on National Science Foundation Project 10831 "serum proteins and hemoglobin electrophoresis of mammals." Dr. Johnson after processing the kangaroo rats reported to the writer that the fleas had not made a mistake, that the specimens from Cedarville were *Dipodomys microps aquilonius* and that the specimens from Fort Bidwell were *Dipodomys hermanni* (Northern California kangaroo rat).

This short paper is the second of a series to be published by the writer under National Science Foundation Grant B 8645 on American fleas; it shows the specificity of these fleas to their host, and expands without doubt the range of the kangaroo rat *Dipodomys hermanni* southeast from Swan Lake Valley, Oregon, where Applegate collected it in 1898 and where the writer has collected it year after year, by 100 miles or so to the south and east, probably out of Oregon through the northern draw into Surprise Valley, California, and with the kangaroo rat its flea *Meringis cummingi*. Since there is no break in the terrain this kangaroo rat and its flea probably range east into Nevada where the host and its hitch-hiker have not yet been recorded. The records:

**Meringis dipodomys** Kohls 1938

From 9 *Dipodomys microps aquilonius* (Chisel tooth kangaroo rat), Cedarville, Modoc county, California, October 16, 1960, 20 males, 18 females, as follows, 1-2-4-6-1-0-16-4-4.

**Meringis cummingi** (C. Fox) 1926

From 9 *Dipodomys hermanni californicus* (Northern California kangaroo rat), Fort Bidwell, Modoc county, California, October 17, 1960, 12 males, 11 females, as follows, 6-2-0-12-2-0-0-1-0.

The skins of the above hosts are in the collection of the museum of University of Puget Sound, the fleas are divided evenly between the United States National Museum and the British Museum.

---

## Notes and News in Entomology

Under this heading we present from time to time, notes, news, and comments. Contributions from readers are earnestly solicited and will be acknowledged when used.

### IVth International Congress U. I. E. I. S.

The International Union for the Study of Social Insects asks that applications for the reading of papers at the Fourth International Congress be sent in as soon as possible, and not later than March 31st. The Congress will be held in Pavia, September 9th to 14th, 1961. It is planned to present symposia on endocrinology, caste differentiation, symbiosis, and on gregariousness and sub-social states. Sections will be held on termites, ants, bees and wasps, and on applied research. Publication of the Proceedings is assured. Applications for membership in the Congress (full members, \$8.00, Associate, \$4.00) should be made before April 30th. Membership cards will be mailed, and applications for accommodations in hotels and University Colleges. Address: Segreteria del IV Congresso Internazionale U. I. E. I. S., Istituto Spallanzani, Università, Pavia, Italy.

## EXCHANGES

This column is intended only for wants and exchanges, not for advertisements of goods for sale or services rendered. Notices not exceeding three lines free to subscribers.

These notices are continued as long as our limited space will allow; the new ones are added at the end of the column, and, only when necessary those at the top (being longest in) are discontinued.

---

**Butterflies.** Wish to exchange specimens for Japanese species. Please write to Ichiro Nakamura (Boy, age 16), 26 Aza-Nichiyama Obayashi Takarazuka-shi, Hyogo-Ken, Japan.

**Phasmidae** of nearctic area desired alive. Purchase or trade, drawing on large stock of major orders, worldwide. Domminck J. Pirone, Dept. Entomology, Cornell University, Ithaca, N. Y.

**Nitidulidae and Rhizophagidae** wanted in exchange for European beetles of all families. O. Marek, Zámberk 797, Czechoslovakia.

**Wanted and Needed.** We are compiling a history of entomology, and particularly, at present, of the amateur insect clubs that flourished 50 to 75 years ago. Will you who have knowledge of such early clubs or societies advise me, giving facts on the time of existence, members, etc., which you may have. J. J. Davis, Dept. of Entomology, Purdue University, Lafayette, Indiana.

**Cockroaches (Blattoidea)** of Japan, Okinawa, Formosa (Taiwan), and the Philippines are being studied in cooperation with Dr. K. Princis. Loans of specimens from that area are desired. A. B. Gurney, U. S. National Museum, Washington 25, D. C.

**Orthoptera. Gryllinae** (except domestic sp.) and **Pyrgomorphinae** of the world wanted in any quantity for work in morphology, taxonomy, cytology, and experimental biology; dry, or in fluid, or living. Write D. K. Kevan and R. S. Bigelow, Dept. of Entomology, McGill University, Macdonald College, Quebec, Canada.



# Important Mosquito Works

**MOSQUITO ATLAS. Part I. The Nearctic Anopheles, important malarial vectors of the Americas, and *Aedes aegypti* and *Culex quinquefasciata***

**MOSQUITO ATLAS. Part II. The more important malaria vectors of the Old World: Europe, Asia, Africa and South Pacific region**

By Edward S. Ross and H. Radclyffe Roberts

Price, 60 cents each (U. S. Currency) with order, postpaid within the United States; 65 cents, foreign.

---

## KEYS TO THE ANOPHELINE MOSQUITOES OF THE WORLD

With notes on their Identification, Distribution, Biology and Relation to Malaria. By Paul F. Russell, Lloyd E. Rozeboom and Alan Stone

Mailed on receipt of price, \$2.00 U. S. Currency. Foreign Delivery \$2.10.

---

For sale by the American Entomological Society, 1900 Race Street, Philadelphia 3, Pa., U. S. A.

---

## Just Published

### New Classified Price Lists

Available separates from the TRANSACTIONS OF THE AMERICAN ENTOMOLOGICAL SOCIETY and ENTOMOLOGICAL NEWS, and all titles of the Society's MEMOIRS have been catalogued by author in twelve special price lists in the following categories:

Coleoptera	Neuroptera and Smaller Orders
Diptera	Odonata
Hemiptera	Orthoptera-Dermaptera
Hymenoptera	Arachnida and Other Classes
Lepidoptera	Bibliography-Biography
Memoirs	General

Lists will be mailed free upon request. Please state specifically which list or lists you require.

**The American Entomological Society**

1900 RACE STREET

PHILADELPHIA 3, PENNSYLVANIA

Just Published

**MEMOIRS OF THE AMERICAN  
ENTOMOLOGICAL SOCIETY**

Number 17

**A TAXONOMIC STUDY OF THE  
MILLIPED FAMILY SPIROBOLIDAE  
(DIPLOPODA: SPIROBOLIDA)**

By William T. Keeton

147 pages of text, 37 tables, 2 maps, 18 plates,  
table of contents and index

Spirobolid millipeds are probably the most widely known Diplopoda in the United States, being used in many college courses; yet the family has been little studied. This monograph brings together existing knowledge of the group for the first time, and adds much new information gained from critical study of series. The taxonomic history of the family is outlined. External morphology is briefly treated, with emphasis on characters utilized in classification. A summary of current knowledge of life histories is included. The family is redefined, and each genus and species is treated in detail. Particular attention is given to variation and distribution, both of which become more meaningful biologically as a result of synonymizing many species names. Possible phylogenetic relationships of the genera are discussed, and keys to all taxa are provided, with most diagnostic characters illustrated in 18 plates or summarized in 37 tables.

Price \$5.50

---

**THE AMERICAN ENTOMOLOGICAL  
SOCIETY**

1900 Race Street, Philadelphia 3, Penna., U.S.A.

ns.

# ENTOMOLOGICAL NEWS

**FEBRUARY 1961**

Vol. LXXII

No. 2

---

**CONTENTS**

Crabill—Catalogue of the Schendylinae, etc. . . . . 29

Nomenclature Notice . . . . . 36

Tilden—Studies in the genus *Ochlodes*, II. . . . . 37

Bradley—The Vienna Congress . . . . . 46

Musser—Dragonfly records from Utah . . . . . 53

Review—Forest and shade tree entomology . . . . . 55

---

PUBLISHED MONTHLY, EXCEPT AUGUST AND SEPTEMBER, BY  
**THE AMERICAN ENTOMOLOGICAL SOCIETY**  
 PRINCE AND LEMON STS., LANCASTER, PA.  
 AND  
 1900 RACE STREET, PHILADELPHIA 3, PA.

---

Subscription, per yearly volume of ten numbers: \$5.00 domestic; \$5.30 foreign; \$5.15 Canada.  
 Second-class postage paid at Lancaster, Pa.



PAID BY ADDRESSEE  
 U.S. MAIL PERMIT NO. 1000 LANCASTER, PA.

# ENTOMOLOGICAL NEWS

---

**ENTOMOLOGICAL NEWS** is published monthly, excepting August and September, by The American Entomological Society at Prince and Lemon Sts., Lancaster, Pa., and the Academy of Natural Sciences, 1900 Race Street, Philadelphia 3, Pa., U. S. A.

**PHILIP P. CALVERT**, Editor Emeritus. **R. G. SCHMIEDER**, Editor. Editorial Staff: **H. J. GRANT, JR.**, **E. J. F. MARX**, **M. E. PHILLIPS**, and **J. A. G. REHN**.

**SUBSCRIPTIONS:** Communications and remittances to be addressed to **Entomological News, 1900 Race Street, Philadelphia 3, Pa.**

Prices per yearly volume of 10 numbers.

**Private subscriptions**, for personal use: in the United States, \$5.00; Canada, \$5.15; other countries, \$5.30.

**Institutional subscriptions**, for libraries, laboratories, etc.: in the United States, \$6.00; Canada, \$6.15; other countries, \$6.30.

**ADVERTISEMENTS:** Rate schedules available from the editor.

**MANUSCRIPTS** and all communications concerning same should be addressed to **R. G. Schmieder, Zoological Laboratory, University of Pennsylvania, Philadelphia 4, Pa.**

The receipt of all papers will be acknowledged and, if accepted, they will be published as soon as possible. Articles longer than eight printed pages may be published in two or more installments, unless the author is willing to pay the cost of a sufficient number of additional pages in any one issue to enable such an article to appear without division.

**ILLUSTRATIONS:** Authors will be charged as follows: For text-figures, the cost of engraving; for insert plates (on glossy stock), the cost of engraving plus printing. Size limit, when printed, 4 × 6 inches. All blocks will be sent to authors after printing.

**TABLES:** The cost of setting tables will be charged to authors.

**SEPARATA:** Members of the American Entomological Society may elect to receive, gratis, 25 offprints of their contributions. These will be "run-off-form," without removal of extraneous matter.

Those members desiring more than 25 separates, and all non-members, will receive no gratis copies. They must obtain all their separates (as reprints, with extraneous matter removed) from the printer at the prices quoted below. Authors must place their order for such separates with the editor at the time of submitting manuscripts, or when returning proof.

Copies	1-4 pp.	5-8 pp.	9-12 pp.	Covers
50	\$4.35	\$6.96	\$10.88	\$4.74
100	5.21	8.26	13.05	6.48
Add'l 100	1.74	2.60	4.33	3.48

Plates printed one side: First 50, \$3.47; Additional 100's, \$2.61.

Transportation charges will be extra.

# ENTOMOLOGICAL NEWS

VOL. LXXII

FEBRUARY, 1961

No. 2

---

---

## A Catalogue of the Schendylinae of North America including Mexico, with a Generic Key and Proposal of a New Simoporus<sup>1</sup> (Chilopoda: Geophilomorpha: Schendylinae)

By R. E. CRABILL, JR., Smithsonian Institution,  
Washington, D. C.

As I have suggested in a previous paper, the chilopod fauna of the montane southeastern United States appears, on the one hand, to be linked with the faunas of northwestern America and eastern Asia, and, on the other hand, with those of the southwestern United States and lands to the south (1958, p. 153). It also has its own apparently distinctive faunal elements.

The idea was advanced with particular reference to the centipedes of the middle and southern Appalachian Mountains, but evidently it may also be true at least of some part of the chilopod fauna inhabiting the Ozark Plateau, a sizeable and very ancient highland just west of the great Mississippi Embayment that may have served as an elevated route of dispersal into the Midwest from the southwestern part of the continent and, in some instances, even from the Mexican Plateau.<sup>2</sup>

<sup>1</sup> This study was undertaken with the aid of a grant from the National Science Foundation.

<sup>2</sup> Since we are dealing with animals of low vagility and, like plants, restricted in distribution by often highly specialized edaphic and environmental moisture requirements, it is of particular interest to note that there is a number of flowering plants whose ranges extend to or toward Texas, or through Texas into Mexico. For particular information on Ozark Plateau plant names, distributions, and possible origins, see Palmer and Steyermark, 1935, especially pp. 414-417.

Through the continuing kindness of Dr. Nell B. Causey, a prominent authority on diplopods and an energetic collector, I have been able recently to study several small but valuable collections of Arkansas chilopods. This material has facilitated the accumulation of a significant body of heretofore unknown information about this poorly-known but geographically meaningful fauna. Range extensions with the discovery of many new localities, clarification of old and often questionable species identities, the discovery of new forms, important new synonymizations and combinations, new variational data—all have resulted from the study of the Causey specimens; much of this information is scheduled to appear in several papers which are in preparation at the time of this writing.

From the standpoint of distribution and faunal affinity, several of the Causey centipedes are of particular interest: a himantariid, *Stenophilus grenadae* (Chamberlin),<sup>3</sup> previously known from one Mississippi specimen whose original description for many years precluded its disposition within the generic system; a rare sogonid, *Sogona poretha* (Chamberlin),<sup>4</sup> otherwise represented only by the typical series from Louisiana; a chilcnophiline, *Watophilus* (*Parawatophilus*) *dolichocephalus* (Gunthorp), known only from the Kansan types; a dignathodontid, *Tomotaenia* (*Korynia*) *urania* Crabill, known only from Missouri. Each is a member either of a higher category or of a genus that is especially characteristic of the West and Southwest, or of the Southwest and Mexico. To this growing list may now be added an additional striking example, a new schendylid, the third-known member of its genus, *Simoporus arcanus*.

The schendylid<sup>5</sup> genus *Simoporus* belongs to that ensemble

<sup>3</sup> New combination. The species was originally referred to *Haplophilus* (Chamb., 1912b, p. 435).

<sup>4</sup> New combination. Originally placed in a new monotypic geophilid genus, *Nannocris* (Chamberlin, 1912b, p. 432), *poretha* here is considered congeneric with the type-species of *Sogona*, *S. minima* Chamberlin; hence *Nannocris* is a junior subjective synonym of *Sogona*.

<sup>5</sup> The present higher categorical interpretation follows that of Attems who considered Schendylidae to be divisible into two subfamilies, Schendylinae and Ballophilinae. Chamberlin, on the contrary, accords to each of these subfamilies full family rank.

of predominantly tropical and subtropical genera <sup>6</sup> characterized by possession of the following features in combination: each coxopleuron has 1, 2, or no gland openings; the second maxillary claws are pectinate; the ultimate leg pretarsi are present and unguiform. In America south through Mexico these genera are *Mexiconyx*, *Morunguis*, *Nesonyx*, *Parunguis*, *Nyctunguis*, and *Simoporus*. (See appended catalogue and notes on *Holityx*.)

Originally described from Texas, *Simoporus* was next recorded from northeastern Mexico: now, for the first time, its range may be extended farther eastward and well northward to the general area of the Boston Mountains in northwestern Arkansas. The evidence seems to indicate a fairly extensive pattern of dispersal, one rather reminiscent of that of the Sogonidae whose more northerly American distribution, broadly speaking, ranges from Mexico through the Gulf States with incursions into the midwestern and southeastern United States.

The new species, *arcanus*, is apparently most like the Mexican *koestneri* Chamberlin, from which it may be distinguished by the criteria presented in the underlying key to the known species.

#### *Key to the Species of Simoporus*

- 1a. Pedal segments numbering 55-61. Mandibular teeth not fused into distinct dentate lamellae (Texas).....*texanus* Chamberlin
- 1b. Pedal segments numbering 39 or 41. Some mandibular teeth (at least in *arcanus*) fused into distinct and typical dentate lamellae.....2
- 2a. Prosternal margin antero-centrally with a pair of flat and small but distinct denticles. 1st maxillae with a pair of distinct telopodite lappets. Male types with 39 pairs of legs (Arkansas).....*arcanus*, new species
- 2b. Prosternal margin antero-centrally without denticles. 1st maxillary telopodites reportedly without lappets (i.e., like those of Verhoeff's figure of *dampfi*, q.v. in catalogue of species). Male types with 41 pairs of legs (Mexico).....*koestneri* Chamberlin

<sup>6</sup> They are tropical or subtropical from the standpoint of their latitudinal distribution. Many are known from high elevations and are probably cold-adapted.

**Simoporus arcanus**, new species

Holotype: ♂. ARKANSAS: Washington Co., 4 miles west of Farmington. June 16, 1950. Nell B. Causey, leg. U. S. National Museum Myriapod collection 2598.

INTRODUCTORY. Length, 10 mm. Pedal segments, 39. Body shape: Very slightly attenuate anteriorly, more strongly so posteriorly; widest at  $\frac{2}{3}$  the antero-posterior length. Color, light brownish-yellow throughout.

ANTENNAE. Length (expanded in Hoyer's mountant), 1.34 mm. Shape: Each article except the first longer than wide; as a whole, filiform; ultimate article equal in length to the preceding two taken together. Vestiture: Sparser on the first 4 or 5, thereafter denser and individually shorter. Ultimate article sensilla: On outer surface only; about a dozen robust, flat and hyaline modified setae arising from a slight ovate depression. CEPHALIC PLATE. Length, 0.38 mm, greatest width, 0.34 mm. Shape: Sides strongly curved; rear margin slightly concave to reveal full width of prebasal plate; dorsally somewhat domed. Coarsely areolate; setae very spare and short. Frontal suture absent; posterior divergent sulci very shallow and weak, each is broad. CLYPEUS (fig. 4). Paraclypeal sutures distinct and complete. Clypeal surface coarsely areolate; without smooth areas (plagulae), without clypeal areas anterocentrally. Setae: postantennals in one series, 1 + 1; posterior geminates (prelabrals), 1 + 1; midclypeals, in two series, 2 + 2, 3 + 3. Buccae: Each coarsely areolate; transbuccal sutures absent; setae absent. LABRUM (fig. 4). Intimately fused with clypeus, not separated from it by sutures. Central embayment broad, even, deep, the teeth numbering about 18, lateral teeth longer and thinner, the more central teeth shorter and more robust, the latter distinctly separated from each other, not fused or forming a crenulate margin. MANDIBLES. Each with two weak but distinct dentate lamellae plus a row of simple hyaline individually discrete teeth. Lamellar teeth of right mandible, 3,3; of the left, 3,4. FIRST MAXILLAE (fig. 1). Coxosternum broad, medially undivided, not suturate; without coxosternal lappets; medial lobes discrete. Each telopodite distinctly biarticulate, with



a prominent but concealed lappet. SECOND MAXILLAE (fig. 1). Isthmus very broad, not sutured, coarsely and strongly areolate. Postmaxillary sclerites attached weakly, terminal in position. Telopodite basally bicondylic; terminal claw broadly spoon-shaped, excavate, each edge with a row of long, delicate pectinae.

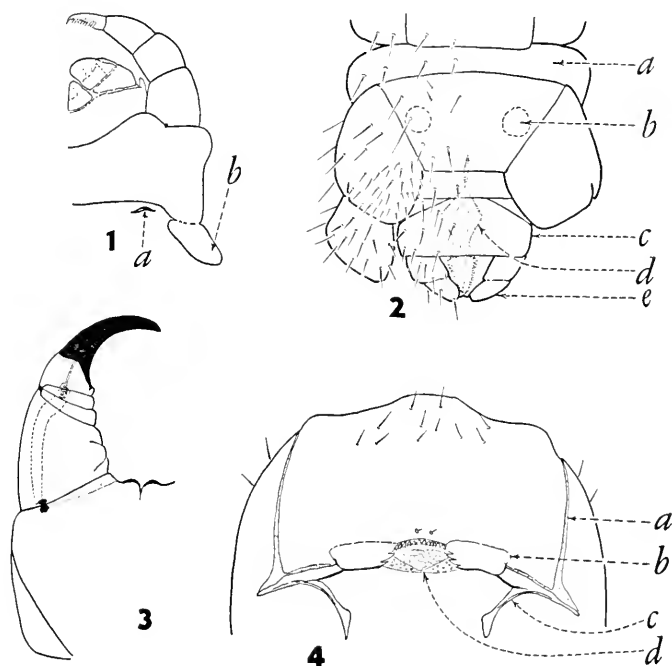

*Simophorus arcanus* new species

1. First and second maxillae. (Ventral aspect; left halves.) Setae deleted. a = metameric pore opening. b = postmaxillary sclerite.

2. Ultimate pedal and postpedal segments. (Ventral aspect.) Setae of right side shown. a = ultimate pedal presternite. b = ultimate pedal sternite covering concealed coxopleural pore (in dashed line). c = genital sternite. d = (in stipple) male intromittent apparatus. e = left gonopod.

3. Prosternum and right prehensor. (Ventral aspect; right side.) Setae deleted. Poison gland in dashed lines, poison calyx and its efferent canal shown in stipple.

4. Clypeus, labrum, buccae. (Ventral aspect.) Setae shown. a = left paraclypeal suture. b = left labral sidepiece. c = left labral fultura, posterior arm. d = epipharynx.

**PROSTERNUM** (fig. 3). Anterior margin centrally with a pair of very low, rather broad, but distinct and pigmented denticles. Subcondylic sclerotic lines absent. Pleuroprosternal sutures prominent, complete to antero-lateral margin. **PREHENSORS** (fig. 3). When flexed, not surpassing anterior margin of head. No article with denticles. Tarsungular dorsal and ventral edges not serrulate; division between ungular and tarsal portion indicated by a weak but nearly complete vestigial suture. Poison calyx ovoid in outline, with relatively long, blunt digitiform appendices; situated in tibiod. Poison gland long and narrow, extending out of the trochanteroprefemur and well into the adjacent somite.

**TERGITES**. Basal plate anteriorly concave, revealing prebasal plate. Each tergite except basal plate and last pedal tergite with a pair of deep, complete sulci. Coarsely areolate and very sparsely setose. **SPIRACLES**. Those of first 3-5 segments subcircular; remaining spiracles essentially circular. **STERNITES**. Each but the first and last much longer than wide; coarsely areolate and very sparsely setose; without apparent sulci; without typical *carpophagus*-structures. Intercalary sternites undivided midlongitudinally; those on rear  $\frac{2}{3}$ 's of body very long front-to-back, bandlike. Porefields: Beginning on pedal sternite 2 and extending through 15; each is undivided and subcircular to slightly antero-posteriorly oval in shape; each field is slightly post-central in position and is very slightly raised.

**ULTIMATE PEDAL SEGMENT** (fig. 2). Pretergite separated from its pleurites by a distinct suture on each side. Tergite much broader than long; sides straight and convergent; rear margin essentially truncate. Presternite antero-posteriorly very long; bandlike, centrally undivided, not suturate. Sternite much wider than long; sides straight and convergent; rear margin essentially straight. Coxopleuron: With one circular, porelike opening concealed completely beneath the sternite; this pore communicating with a tubular chamber which is part of a large glandular structure of the homogenous type. Ultimate leg: About 25% longer than the penult; moderately inflated; tarsus consisting of two articles; pretarsus is large and distinctly ungui-

form; the two tarsal articles abruptly thinner than the more proximal articles; trochanter through tibia clothed subdensely with short, bristlelike setae, the tarsus with longer and fewer setae; dorsally all articles sparsely clothed with long stiff setae.

POSTPEDAL SEGMENTS (fig. 2). Gonopod biarticulate but very indistinctly so; long and narrow. Terminal pores absent.

Paratype: ♂. See collection data for holotype. The only other specimen is virtually identical with the holotype. It differs only in being somewhat lighter in color.

KEY TO THE SCHENDYLINAE GENERA OF NORTH AMERICA  
INCLUDING MEXICO

- 1a. Each coxopleuron with more than 2 gland openings; the openings are true pores and are normally numerous. Ultimate pretarsus is unguiform (*Escaryus*, *Apunguis*) . . . . . 2
- 1b. Each coxopleuron with 1 or 2, or with no gland openings; the openings are either typical pores, being small and essentially round, or they are larger and cleft- or slit-like apertures. Ultimate pretarsus, when present, is either unguiform or tuberculate . . . . . 3
- 2a. Second maxillary claw is pectinate . . . . . **Escaryus** Cook and Collins
- 2b. Second maxillary claw is smooth . . . **Apunguis** Chamberlin
- 3a. Each coxopleuron without a gland opening. Second maxillary claw is pectinate. Ultimate pretarsus is present and unguiform . . . . . **Nesonyx** Chamberlin
- 3b. Each coxopleuron has 1 gland opening; this is often concealed and usually pore-like. Second maxillary claw is pectinate. Ultimate pretarsus is present and unguiform (*Simporus*, *Mexiconyx*, *Morunguis*) . . . . . 4
- 3c. Each coxopleuron has 2 gland openings. Second maxillary claw is pectinate or smooth. Ultimate pretarsus, when present, is unguiform or tuberculate (*Parunguis*, *Serrunguis*, *Nyctunguis*, *Schendyla*, *Pectiniunguis*) . . . . . 6
- 4a. Ventral porefields are absent on all pedal sternites . . . . . **Morunguis** Chamberlin
- 4b. Ventral porefields are present on at least the more anterior pedal sternites (but they may occur on most or all sternites) . . . . . 5
- 5a. Prehensors when flexed extend far beyond the anterior head margin . . . . . **Mexiconyx** Chamberlin

- 5b. Prehensors when flexed do not extend beyond the anterior head margin and may fall short of it.....**Simoporus** Chamberlin
- 6a. Ventral porefields absent on all pedal sternites (*Serrunguis*, *Parunguis*).....7
- 6b. Ventral porefields present on most or all, or at least on the more anterior pedal sternites (*Nyctunguis*, *Schendyla*, *Pectiniunguis*).....8
- 7a. Second maxillary claws are pectinate. Ultimate pretarsus is small, weak, and unguiform. Prehensorial blade edges apparently not serrulate.....**Parunguis** Chamberlin
- 7b. Second maxillary claws are smooth. Ultimate pretarsus is slender and tuberculate. Prehensorial blade edges are serrulate.....**Serrunguis** Chamberlin
- 8a. Second maxillary claws are smooth. Ultimate pretarsus is absent.....**Schendyla** Bergsøe and Meinert
- 8b. Second maxillary claws are pectinate. Ultimate pretarsus is absent, or minute and vestigial, or present and unguiform.....9
- 9a. Ultimate pretarsus is present and unguiform. Coxopleural gland pits are homogenous, i.e., lack constituent gland canals.....**Nyctunguis** Chamberlin
- 9b. Ultimate pretarsus is absent or present; if present, then it is vestigial and essentially tuberculate. Coxopleural gland pits are heterogenous, i.e., are composed of constituent glands and large gland canals.....**Pectiniunguis** Bollman

(To be continued)

### Nomenclature Notice

All comments should be marked with the Commission's number and sent in duplicate to W. E. CHINA, British Museum (Natural History), Cromwell Road, London, S.W.7, England, before June 5, 1961. Comments received early enough will be published in the Bulletin. For details see Bull. Zool. Nomencl. 18 (1-3).

Suppression of 56 generic names published by Meigen, 1800 (Diptera) (Z.N.(S.) 191). Validation of the generic name **Myelophilus** Eichoff, 1878 (Coleoptera) (Z.N.(S.) 467). Designation of a type-species for **Euceraphis** Walker, 1870 (Hemiptera) (Z.N.(S.) 1363). Validation of the generic name **Perla** Geoffroy, 1762 (Plecoptera) (Z.N.(S.) 1451).

## Studies in the Genus *Ochlodes* Scudder. II. The Type Material of the North American Species (Lepidoptera: HesperIIDae)

By J. W. TILDEN, San Jose State College,  
San Jose, California

The first paper of this series dealt with the distribution of *Ochlodes yuma* (Edw.). This paper deals with the location of type specimens of the North American species of the genus.

The names proposed by W. H. Edwards do not have designated holotypes, since the practice of designating individual specimens as holotypes was not general at that time. Rather, whatever specimens were before Edwards at the time he penned his descriptions, were all considered equal, that is, cotypes or syntypes. If there existed but a single unique specimen it is automatically the holotype under existing rules. Where two or more specimens are known to exist, it seems desirable to designate one of these as the lectotype of the name.

It has been called to my attention by F. M. Brown, that C. L. Remington (1947) published an excerpt from the minutes of the Cambridge Entomological Club, as follows: a "collection of butterflies, containing the types of seventy rare species of *Hesperia*" had been on board the ship *Pomerania* when she was lost. One may postulate that this unfortunate event is responsible at least in part for the difficulty encountered in tracing and recognizing some of the specimens upon which W. H. Edwards based his names.

The names that in the Checklist of Lepidoptera of Canada and the United States of America (McDunnough, 1938) are considered as belonging to the genus *Ochlodes* Scudder follow:

*morrisoni* Edw.  
*sylvanoides* Bdv.  
*pratinicola* Bdv.  
*nemorum* Bdv.  
*agricola* Bdv.  
*napa* Edw.  
*yrcka* Edw.

*verus* Edw.  
*milo* Edw.  
*snovi* Edw.  
*yuma* Edw.  
*scudderi* Skin.  
*francisca* Ploetz

To these, Evans (1955) has added another :

*amanda* Ploetz

An attempt has been made to locate the type material of each name and to discuss its status, but this paper is not concerned with the ascertaining of the number of valid species or subspecies represented by these names. This must wait on further study.

**Pamphila morrisoni** Edw. 1878 was described "from several examples taken by Mr. Morrison in Southern Colorado." *Morrisoni* was included in *Pamphila* (*Hesperia* in the current sense), by Lindsey (1921). In 1931, Lindsey, Bell and Williams removed it to *Ochlodes*. Evans (*tom. cit.*, p. 317) erected for its reception the monobasic genus *Stinga*. Since *morrisoni* has been somewhat anomalous in the genera in which it has previously been included, perhaps the solution offered by Evans is as good as any.

The types of the Boisduval names, *sylvanoides*, *agricola*, *nemorum* and *pratincola*, are deposited in the British Museum (Natural History) in London, England, whence they came through the purchase in 1931 of portions of the Oberthur collection. Information on this point, and citation of the type specimens under each name, are presented by Evans (*tom. cit.*).

Boisduval's description of **Hesperia sylvanoides**, 1852, includes the description of both sexes. No definite locality nor number of specimens appears in the description. But his comment, "Assez commune en Mai," is puzzling, in view of the generally accepted use of this name for a late-flying insect.

**Hesperia agricola** Bdv. 1852 was described from the male only. Boisduval writes "Je ne connais pas la femelle." The description gives no clue as to the exact locality nor to the number of males at hand. The above remarks apply equally well to the description of **Hesperia nemorum** Bdv. 1852, of which he says "Nous n'avons pas vu la Femelle." **Hesperia pratincola** Bdv. 1852 was described from both sexes, but again without exact locality nor number of specimens. However, in view of Boisduval's practice of designating holotypes, there seems to be

no reason to doubt the authenticity or proper designation of any of his types of American *Ochlodes*.

Concerning the names proposed by W. H. Edwards, more confusion exists. Specimens that may be regarded as most likely to include type material of these names, exist among the collections of the Carnegie Museum, Pittsburgh, Pennsylvania. Correspondence with curators of other museums has failed to reveal specimens equally deserving of consideration in this respect, for the names *napa*, *yreka*, *milo* and *verus*. Each will be dealt with below.

**Hesperia napa** Edw. 1864 was described from specimens "Taken by Mr. Ridings at Empire City, Colorado Territory." Since both sexes are described, Edwards had before him at least a pair, but the number of specimens is not stated. Correspondence has failed to reveal specimens known definitely to have been collected by Ridings. Dr. Clench informs me that there are in the Carnegie Museum, four specimens representing the name *napa* Edw., two males and two females. The Ridings collection supposedly came in its entirety to the Academy of Natural Sciences of Philadelphia, but Mr. James A. G. Rehn states (*in litt.*) that "what is certain is that in our series [of *napa* Edw.] there is no material which we can definitely say came as part of the Ridings collection." Mr. Rehn considers it probable that this material was not returned to Ridings by Edwards. Since a great part of the Edwards collection went to the Carnegie Museum, it is suggested that the specimens of *napa* housed there represent at least a part of the Ridings material as described by Edwards. From the previously mentioned four specimens, the first specimen is hereby selected as the lectotype of *napa* Edw. It is a male bearing the following labels: (1) "Napa, Colo," penned in W. H. Edwards' handwriting (2) "Collection of W. H. Edwards," letterpress in box (3) "Probable type of *Napa*, M. W. D., 1955," written in pencil by B. W. Dixon.

**Hesperia yreka** Edw. 1866 was described from "San Francisco" without reference to the number of specimens at hand. This name is represented in the Carnegie Museum by an unique

male, with one antenna, and with mesothoracic and metathoracic legs missing on one side, but with abdomen present, and otherwise in good condition. It bears the labels (1) "nemorum yreka ES. Cal<sup>a</sup>" and (2) "Collection W. H. Edwards." Since it is an unique, it may very well be the original type, but to prevent future misunderstandings it is hereby designated as the lectotype of *yreka* Edwards. The collector is not stated, but both Kennicott and Bischoff are known to have supplied Edwards with material from the San Francisco area.

**Pamphila verus** Edw. 1881 was described "From 1 male, 1 female, taken at Havilah, California; and in the collection of Mr. Henry Edwards." In the Carnegie Museum are two specimens, one male, one female. The female has antennae and abdomen but is missing four legs. The male has one antenna, the other being replaced by a bristle (!). All the legs are present. The abdomen is missing but I am informed by Clench that no genitalic preparation of this specimen is known to exist. This male bear the labels: (1) "6668," (2) "Havilah, Calif.," (3) "Verus So. Cal<sup>a</sup>," (4) "Collection of W. H. Edwards," and (5) "Butterfly Book Pl. 52, fig. 42." It is regrettable that this male is missing the abdomen, but since it is highly probable that this is the actual male upon which the description of *verus* is based, and considering that it is the specimen figured by Holland (1930), this male is hereby designated as the lectotype of *verus* Edwards.

**Pamphila milo** Edw. 1883 was described "From 1 male, from Mt. Hood, Oregon." In the Carnegie Museum there is an unique male bearing the labels: (1) "Milo W. T. Mor.," (2) "Collection W. H. Edwards," and (3) "Butterfly Book Pl. 52, Fig. 44." It is to be noted that Edwards did not mention in his description that the specimen was collected by Morrison. Except for this, it seems probable that the specimen under consideration is the original type of *milo* Edwards. For uniformity, this male is hereby designated as the lectotype of *milo* Edwards.

Specimens of **Pamphila snowi** Edw. 1877 exist in the collections of several institutions, but those in the collection of the



University of Kansas seem most plausibly to contain a specimen which may be one of those before Edwards when he penned his description. Edwards described *snowi* "From 2 males sent me by Prf. F. H. Snow, and taken by him in Colorado, at Ute Pass, while in charge of the Kansas University Expedition, 1876. No others were taken, as I am informed." Three specimens are in the collections of the University of Kansas. One is labelled "So. Arizona, Poling." A second is labelled: (1) "Near Hot Springs, N. M., 7,000 ft., July '82. F. H. Snow," (2) "15," and (3) *Ochlodes snowi* Scudd. det. A. W. Lindsey 1938." These two specimens are excluded from consideration since the type material came from Colorado. Moreover the first specimen is collected by Poling and the second is a female taken six years later than the types were cited as being collected. The third specimen is a male, bearing the labels: (1) "Col. Snow," (2) *Pamphila snowi* Edw. 523," and (3) "*Ochlodes snowi* Scudd. det. A. W. Lindsey 1938." Dr. George W. Byers of the University of Kansas tells me (*in litt.*) that none of these three specimens bears type labels nor is catalogued in the type file. Edwards mentions specifically, two type specimens. The location of the second specimen has not to date been found; it may be lost. Was it on the ill-fated Pomerania? Since this third specimen was collected by Snow, and is not definitely stated to be of another time and place than those mentioned by Edwards in his description, it is hereby designated as the lectotype of *snowi* Edwards.

It is interesting to note the determination labels "*Ochlodes snowi* Scudd. (*sic!*) det. A. W. Lindsey 1938." Byers had no information on this point. Dr. Lindsey himself informs me (*in litt.*) that he did not know he had inadvertently made this slip, until it was called to his attention.

Edwards described *Hesperia yuma* Edw. 1873 "From a single male received from Arizona by Lieut. Wheeler's expedition of 1871." This unique type no longer exists. Holland (1930, p. 379) states that the type is "mysteriously missing." This statement is most interesting in view of a part of a letter to Holland from Edwards, the substance of which has kindly been

made available to me by F. M. Brown. This letter, dated "11 Dec. '85," reads in part: "Hesp. Yuma one ♂, Lost by fire which destroyed the Express car, about 1873 or 74, & burned a lot of Arizona things I had just recd. These were in transit to Scudder. Have never seen the species since." It would appear that the elderly Holland by 1930 had forgotten this earlier note from Edwards. *Ochlodes yuma* is not mentioned in the first edition of the Butterfly Book.

Tilden (1958, pp. 151-152) has assembled a list of known specimens of *yuma* Edw., both in museums and in a number of private collections. Brown (1958, pp. 153-154) has traced the route of the Wheeler expedition and the dates at which it visited the areas of southwestern United States where the type of *yuma* Edw. might have been taken. These authors agree that the stated type locality, Arizona, seems unlikely. It is much more plausible to consider that the type specimen may have been taken in Inyo County, California. The Wheeler expedition ended in Arizona. This appears to be the most likely reason for labelling the collections of this expedition as having been taken in Arizona. As has been suggested for other names than *yuma* Edw. (e.g., the nymphalid name *apacheana* Skinner) it would seem that this procedure is at least partly in error.

Therefore it is suggested, that until further information is obtained, Inyo County, California, be regarded as the type locality of *yuma* Edw. The reasons for this suggestion are cogent (see Brown, *op. cit.*). Only if incontrovertible evidence, favoring Arizona as the type locality, should be brought forward, would it seem desirable to set aside this change in type locality.

A specimen of the fall brood of *Ochlodes yuma*, taken in the general vicinity of where the Wheeler Expedition crossed the area, has been selected. It is a male, and differs from the description of *yuma* Edw. only in having dark wing borders. The lost type was evidently a worn specimen. Fresh specimens of *yuma* nearly always have narrow dark borders. This specimen bears the labels "Darwin Falls, Inyo Co., Calif., IX.10.60," "J. W. Tilden Collector" and "Neotype of *yuma* Edw, desig. J. W. Tilden 1960." This specimen is hereby designated as the

neotype of *yuma* Edw. to replace the original type believed to have been destroyed by fire in 1873 or 1874. This specimen will be deposited in the Carnegie Museum, Pittsburgh, Penna.

The types of **Pamphila scudderi** Skinner 1899 are in the collections of the Academy of Natural Sciences at Philadelphia, Pennsylvania. Mr. Rehn has informed me that the labels are in longhand without indication of collector and that the specimens are in perfect condition. Gillham and Ehrlich (1954) state that the male holotype is #7097. The labels bear the data: "White R., Col., July 24-Aug. 13." The original description says: "Described from a pair sent to me by Dr. S. H. Scudder who has a good series in his collection. They were taken on the White River. . . ."

It is not certain by whom these specimens were marked as types. Nothing in Skinner's description states that he did so. It is possible that it was done by R. C. Williams, Jr., who worked at that institution. Search of the literature does not clear up this point, and Mr. Rehn states that he does not know. It is possible that the citation has never formally been published, or that I have failed to find it. However, there seems to be no reason to doubt the authenticity of the male holotype of *scudderi*, and the present author agrees that these specimens are the types of *scudderi* Skin.

The names proposed by Ploetz present a very difficult problem. Correspondence with Dr. W. Forster, of the Zoologische Sammlung des Bayerischen Staates, and with Dr. H. J. Hanne-mann, of the Humboldt-Universität zu Berlin, have confirmed the generally suspected conditions surrounding the published names of Ploetz. In many cases no type specimens were designated. In other cases, the "types" were divided and sent to different institutions. Many times water-color plates (Aquarellen) were made of the type specimens. These plates were in some cases used in Seitz' *Macrolepidoptera of the World*. These plates now exist in several museums of the world, not only in Germany, but also in the British Museum (Natural History), London, England, and in the Museum of Rio de Janeiro, Brasil. So far as can be ascertained, the type specimens of the two

Ploetz names with which this article is concerned, are not to be found.

**Francisca** Ploetz 1883, by the nature of the description and by the type locality ("Californien, Mexico"), indicates a synonym of *sylvanoides* Boisduval 1852. Since the type material of *francisca* Ploetz has so far remained unlocated (if indeed it exists), it seems necessary on the basis of the description to retain the name *francisca* for consideration among those of North American insects. The case for the name **amanda** Ploetz 1883 is less clear. This name was added to those of the North American members of the genus *Ochlodes* by Evans (*tom. cit.*, p. 343, 1955). Bell (1938) considers *amanda* Ploetz a questionable synonym of *Hesperia parvnee* (Dodge). Most other American authors seem to have ignored the name. Evans' basis is a copy of Ploetz' MS. figure in the British Museum (Natural History). On the basis of the general lack of agreement as to what Ploetz really had before him when he proposed the name *amanda*, perhaps as good a disposition of the name as any is to consider it a *nomen dubium*. This course is here adopted.

Except for the names proposed by Ploetz and concerning which there is some doubt as to their disposition, there has been no attempt in this paper to decide on the taxonomic validity of any of the North American names in the genus *Ochlodes*. This phase of the study is now under consideration but so far the results are inconclusive.

The author gratefully acknowledges the help of the following individuals and the institutions they represent: Dr. F. Martin Brown, Fountain Valley School, Colorado Springs, Colo.; Dr. George F. Byers, University of Kansas, Lawrence, Kan.; Dr. Harry K. Clench, Carnegie Museum, Pittsburgh, Penna.; Dr. J. P. Darlington, Jr., Museum of Comparative Zoology, Cambridge, Mass.; B. W. Dixon, Pittsburgh, Penna.; the late Brigadier W. H. Evans, British Museum (Natural History), London, England; Mr. W. D. Field, Smithsonian Institution, Washington, D. C.; Dr. W. Forster, Zoologische Sammlung des Bayerischen Staates, München, Germany; Dr. H. J. Hanne-  
mann, Humboldt-Universität, Berlin, Germany; Dr. Frederick

H. Rindge, American Museum of Natural History, New York, N. Y.; Mr. James A. G. Rehn, Academy of Natural Sciences, Philadelphia, Penna. Each has contributed information that has proven valuable. Special thanks are due to Dr. A. W. Lindsey, Emeritus, Denison University, Granville, Ohio, for his many kindnesses over the years.

## LITERATURE CITED

- BELL, E. L. 1938. The Hesperioidea. Bull. Cheyenne Mt. Mus. 1(1): 23-24.
- BOISDUVAL, COMTE DE. 1852. Ann. Ent. Soc. France (2)10, pp. 313-315.
- BROWN, F. M. 1958. The type locality of *Ochlodes yuma*. Lep. News 11: 153-154.
- EDWARDS, W. H. 1877. Can. Ent. 9: 29.  
1883. Can. Ent. 15: 34.  
1878. Field and Forest 3: 116.  
1864. Proc. Ent. Soc. Phil. 4: 202.  
1866. Proc. Ent. Soc. Phil. 6: 207.  
1873. Trans. Am. Ent. Soc. 4: 346.  
1881. Trans. Am. Ent. Soc. 9: 4
- EVANS, W. H. 1955. A catalogue of the American Hesperiidæ, Part IV, p. 317, 341-343.
- GILLHAM, N. W. and P. R. EHRLICH. 1954. The butterfly types of Henry Skinner and co-authors in the Academy of Natural Sciences of Philadelphia. Trans. Am. Ent. Soc. 80: 91-117.
- HOLLAND, W. J. 1930. The Butterfly Book, rev. ed. Pp. 377-380, & plates.
- LINDSEY, A. W. 1921. The Hesperioidea of America north of Mexico. Univ. Iowa Studies in Nat. Hist. 9(4): 75-77.
- LINDSEY, A. W., E. L. BELL and R. C. WILLIAMS, JR. 1931. The Hesperioidea of North America. Denison Univ. Bull. Journ. Sci. Labs. 26: 94-96.
- PLOETZ, C. 1883. In Stett. Ent. Zeit. 44: 220.
- REMINGTON, C. L. 1947. (Quotation from minutes of the Cambridge Ent. Club Proc. of 13 Dec. 1878.) In Lep. News 1: 83.
- SKINNER, H. 1899. Ent. News 10: 111.  
1900. Ent. News 11, pl. II, figs. 9, 10.
- TILDEN, J. W. 1958. Taxonomic history and distribution of *Ochlodes yuma*. Lep. News 11: 151-152.

## The Vienna Congress

For the eleventh time within this century the entomologists of the world have assembled in conference to discuss their research and problems, and to meet their world-wide colleagues. This time the meeting was in Vienna, a city classical to adherents of our science, because of the illustrious entomologists of the past century who worked and published there. The growing importance of these congresses is shown by the large attendance, which this time almost reached the two thousand mark. The unusually large number of North Americans in attendance was certainly due to the liberality of our National Science Foundation and National Institute of Health in awarding forty-one travel grants.

This Congress was held under the presidency of Prof. Karl E. Schedle, noted forest-entomologist, while Dr. Max Beier of the Natural History Museum was Secretary General.

The scientific meetings were divided between the Natural History Museum—the famed Naturhistorisches Hofmuseum of former years—and the mid-Victorian building of the University, which, with its high ceilings and great marble staircases, was quite formidable to those who had to climb to lecture rooms located up under the roof. Two other buildings were also used to some extent.

The most unusual feature of this congress was the great number of symposia, seventeen in all. While these symposia dealt with restricted topics, they did not, in general, deal with selected aspects of a particular topic, so could possibly better have been distributed under section headings. As there were only six days of scientific sessions, the symposia had to be held concurrently, not only with the section meetings, but with each other. Under the arrangement followed, identical subject matter was sometimes simultaneously dealt with in both symposium and section, as for example, all day Monday, the symposium on chemistry of insects was running concurrently with the section on physiology (morning, nourishment, and afternoon, histochemistry).

In addition to the symposia, there were twenty-five sections and subsections running more or less simultaneously with each other and, as already noted, with the symposia. As these were held in four buildings somewhat remote from one another, the members who wished to pick and choose particular papers to hear, were decidedly frustrated. Matters were made worse by the fact that some members did not respond when their papers were called.

## I. THE SUBJECT MATTER

The scope of topics dealt with, both in symposia and sections, will be apparent from what follows:

### A. Systematic and General Entomology

*Fundamental problems of systematics and nomenclature*, Symposium No. 17, was under the leadership of Professor E. Martini of Hamburg, who was the president of the Berlin Congress in 1938. There were thirteen papers that, as could have been anticipated, elicited long and vigorous discussion.

*General systematic entomology*—Section I. Mr. H. J. Stammer gave a paper on "New paths in insects systematics," Dr. R. R. Sokol of the University of Kansas on, "Fundamentals of quantitative systematics," Dr. A. Nielsen of Copenhagen gave "Some thoughts on arthropod phylogeny," Mr. J. P. Cancelo da Fonseca of England gave a critical essay on "The evolution of insects," and Prof. R. M. Bohart, of the University of California, gave a paper on "The art and practice of key-making."

*Taxonomy of entomophagous insects*, a symposium under the leadership of Prof. Charles Ferrière, of Geneva, included six papers. A notable one by Dr. Henry Townes, of Michigan, outlined the results of many years research toward a more natural classification of the Ichneumonidae.

*Palaeontology*, was under Prof. F. E. Zeuner of London, who reported on Triassic insects from the Moltano beds of southern Africa. Among other papers was one by Prof. Rohdendorf of

Moscow, on paleontological research in Russia, which, as everyone knows, has been of great significance.

*Hemimetabola*.—Dr. V. M. Dirsch of London and Dr. A. G. Sharov of Moscow, both presented papers on the classification of orthopterous insects, while Mr. D. Lester of London spoke on the higher taxonomy of Heteroptera. There were twenty-three papers.

Three of the most primitive orders of winged insects were each the subject of a special symposium, they could as well have been made subsections of Section I. *Ephemeroptera*; there were seven papers on taxonomy, biology and distribution; *Plecoptera*; there were six papers on taxonomy, anatomy, and behavior, including an important one by Dr. Illies of Plön in Germany on the suborders and families; *Odonata*; this consisted of eight papers. One, on family classification, was by Prof. B. E. Montgomery of Lafayette, Indiana.

*Colcoptera*.—Among the eighteen papers was one of "Progress toward a classification of Rhynchophora" by Dr. W. H. Anderson of Washington.

*Diptera*.—Among nineteen papers two of the more general ones on classification were by Prof. Rohdendorf of Moscow, and by Dr. Curtis W. Sabrosky of Washington. A phylogenetic system of syrphoids based on genitalia and larvae was offered by Mr. S. Glumac.

*Lepidoptera*.—Included among nine papers, was one on the classification of Tortricidae by A. Diakanoff of Leiden, and one on a generic classification of the Papilionidae by K. H. Wilson of the University of Kansas.

*Hymenoptera*.—There were eleven papers. Dr. J. R. T. Short, of Aberdeen, presented "The taxonomy of Ichneumonidae from the standpoint of larval characters." (Cf. Dr. Townes' paper on the classification of that family in one of the symposia.)

*Arachnida*, had twelve papers.

## B. Geographical Distribution

Section 4 had fifty-five papers, a very interesting program.



## C. Behavior and Social Insects

Section 5, had twenty-two papers.

*Migration*, a symposium, was under the leadership of Dr. B. P. Uvarov of the British Museum, authority on migrating locusts. There were twenty-three papers on this popular topic, and they dealt with aerial dispersal and many other phases of the subject in a wide variety of insects, from plant-lice to butterflies.

*Host-seeking habits of mosquitoes*, had seven papers.

## D. Ecology

*Soil insects*, a symposium that was led by Professor Kühmelt of Vienna; eleven papers.

*Insects of great cities*.—This symposium had twelve papers several of which dealt with applied entomology.

## E. Anatomy, Embryology, Cytology, and Genetics

*Anatomy and embryology*.—This section had thirty-nine papers; *Genetics and Cytology*, had fifteen papers.

## F. Physiology

Section 6, which also included experimental ecology, was led by Dr. Kühmelt and listed sixty-six papers; one of these on a somewhat unusual topic, by Dr. T. R. E. Southwood of England, was entitled "The evolution of the insect host-tree relationship—a new approach."

*Acoustics*, a symposium. The ten papers included a review of progress and problems by the leader, Dr. P. T. Haskell of London.

*Chemistry*, a symposium, comprised forty-nine ten minute papers on a wide range of subjects.

*Chemical defensive methods*.—A symposium led by Prof. Thomas Eisner of Cornell University, with eight papers, some on resistance to insecticides.

### G. Medical and Veterinary Entomology

Section 10 had seventy-two papers, more than in any other group. I will mention two papers: "The use of external characters to age-grade adult mosquitoes" by Dr. Philip S. Corbett of Entebbe, Uganda (a field of entomology that I have not previously seen touched upon) and "The ecological classification of synanthropic flies of the families Muscidae and Calliphoridae" by V. P. Darbeneva-Ukhova. There was also a film showing association of a mosquito with oriental ants (*Crematogaster*).

*Acarina*.—A symposium with eleven papers.

*Arthropods in relation to blood-parasites, especially those of wild animals*.—A symposium with twelve papers led by Prof. A. Murray Fallis of Toronto.

### H. Applied Entomology (non medical)

*Agricultural entomology*.—Two of the fifty-six papers were "Status of the idea that weather can control insect populations," by M. E. Solomon of England, and "Recent advances in the study of insect resistance in crop-plants of North America" by Prof. R. J. Painter of Kansas State Agricultural College.

Thirteen other sections, subsections and symposia were devoted to various phases of agricultural and forest entomology. There were in all 212 papers on their programs.

### I. Conservation

Section 14 had the least number of papers, just two; one was of local significance, the other, by Dr. H. W. Miles of Wye, England, was entitled "Some entomological aspects of nature conservation."

### J. Films

On four afternoons and one morning, programs of excellent films (eleven on behavior, nine on control, eight on expeditions, and eight on miscellaneous topics) afforded both pleasant and instructive relief from the monotony of listening to too many papers.

## II. EXCURSIONS

By invitation of the Burgomeister, daily opportunity was afforded to see the "New Vienna" by autobus. Afternoon excursions to points of interest were made available to all ladies of the Congress. There was one all-day excursion to points of technical interest for each of four Sections: Agriculture, Stored Products, Control Methods, and Forest-Entomology.

On Saturday and Sunday a choice of delightful all-day excursions was offered to such famed points of interest as the Wachau and the Monastery at Melk, the Rax, Petronell and the Caruntium Museum, and the Neusiedler See.

Those who wished to prolong their stay for post-congress field work had the choice of three additional excursions by autobus; one of three days for agriculturalists and two longer ones (nine and twelve days) for alpine collectors. I took no part in these excursions, therefore can give no report on how the participants fared, or even that there were enough registrants to ensure that they were all given.

## III. SOCIAL EVENTS

As always at these congresses, the most pleasant feature was the evening social gatherings, when one has opportunity to meet old friends, leisure for conversation with them, and perhaps chance to meet, in the flesh, celebrities who have hitherto been known only from their published articles. There were two such evenings at the Congress, to which everyone was invited, each truly memorable; the first was a general reception given by the Burgomeister in the great Festhall of the Rathaus, the second was the closing reception given by the Organization Committee in the Museum.

Also, there was an affair for members of the Lepidopterist's Society, one for invited Coleopterists by the Museum "Dr. George Frey" in Munich, and two others for delegates invited, respectively, by the Minister of Agriculture and Forestry, and by the Minister of Education.

On the evening of the closing day, opportunity was given to visit a "Heurige" in Grinzing. These are held in local establishments, famous to the Viennese; they celebrate the coming of the season's new wine, and when it is ready a pine branch, known irreverently as "The finger of God" is hung before the door.

#### IV. THE CLOSE

At the closing session, it was announced that the next Congress will be held in London in 1964, that Dr. Curtis W. Sabrosky had been elected to the Permanent Committee of the Congresses (in the place of this writer, resigned) and that Dr. E. M. Hering of Berlin had been an Honorary Member (there are now two honorary members from the United States\* and one each from Brazil, France, Germany, Austria, and Japan).

As we scattered far and wide, I think all congressionists must have left with the feeling, not only of having had a most enjoyable and professionally profitable week, but that here had been a congress that fully measured up to the standards of congresses in the past, as would have been expected from our hosts, the Austrians; perhaps it has set new standards! Surely each and every one of us felt profound gratitude for what had been done both for us and as a stimulus to our science.

J. CHESTER BRADLEY

\* Dr. O. A. Johannsen, and Dr. J. Chester Bradley.—EDITOR.

## Some Noteworthy Dragonfly Records from Utah (Odonata: Anisoptera)

By R. JEAN MUSSER,<sup>1</sup> University of Utah, Salt Lake City

The only published records of the Odonata fauna of Utah are found in the broad, general works of Needham and Heywood (1929), Needham and Westfall (1955), and in a few checklists and general reports. The only other published Odonata records of Utah are by Brown (1934), G. G. Musser (1959) and R. J. Musser (1960).

Two southern species, *Oplonaeschna armata* Hagen and *Brechmorhoga mendax* Hagen, which extend into Utah from Mexico and Central America, are herewith reported as new distributional records for the state.

One nymphal exuvia and one male adult *Oplonaeschna armata* Hagen were taken at Weeping Rock in Zion Canyon (elevation 5,000 ft.), Washington Co., Utah near a small stream formed by water seeping between bedding planes of a Navajo Sandstone cliff. Here the water falls from a sandstone arch, causing a fine spray which continually moistens the immediate vicinity. The small stream is subject to flash flooding when rain from thunderstorms runs off the surrounding sandstone cliffs. This distinctive habitat appears to be very similar to that from which Tinkham (1949) collected this species in Arizona. Until the exuvia and adult were taken in Utah, Tinkham's specimens were the only representatives of this species to be reported in the United States. The site of collection in Zion Canyon represents a 400 mile northward range extension of *O. armata*.

The other southern species for which Utah now represents the northernmost limit is *Brechmorhoga mendax* Hagen. Three last instar nymphs were collected with a hand screen in the Santa Clara River (elevation 5,500 ft.) at Veyo, Washington Co., Utah. The stream here is approximately 4 feet wide and 1½ feet deep. Warm springs feed its moderately fast current.

<sup>1</sup>Summer Graduate Teaching Fellow, N.S.F., Graduate Research Fellow, Department of Zoology and Entomology.

At intervals the stream drops from a gravel and rock bottom overlaid with algae into pools with a sand and silt base.

*Brechmorhoga mendax* was found in close association with *Progomphus borealis* McLachlan and *Erpetogomphus compositus* Hagen in the shallow and riffled edges of the Santa Clara River. The three specimens of *B. mendax* were found in a two foot square area although a much larger section of the stream was exhaustively collected. The stream bottom along the course appears identical to the collecting site of *B. mendax*, and since no water temperatures were taken, there is no available data which will explain failure to find it elsewhere.

The dragonfly fauna of southwestern Utah would seem to support the hypothesis that this area marks the route for the northern dispersal of some southern species of aquatic insects, as well as more southerly distributed plants and animals.

#### SELECTED REFERENCES

- BROWN, C. J. 1934. A preliminary list of Utah Odonata. Occasional Papers of the Museum of Zoology, Univ. of Mich. Press, No. 291, Ann Arbor, Mich.
- GREGORY, H. E. 1950. Geology and geography of the Zion Park Region, Utah and Arizona. U. S. Geological Survey Professional Paper, 220, Wash., D. C., pp. 1-200.
- LARSEN, W. P. 1952. The Dragonflies (Anisoptera) of Utah. Unpub. Master's thesis, Univ. of Utah, pp. 1-95.
- MUSSER, G. G. 1959. Annotated checklist of aquatic insects of Glen Canyon, in "Ecological studies of the flora and fauna in Glen Canyon," Angus Woodbury *et al.* Univ. of Utah Anthro. Papers, No. 40, Glen Canyon Series, no. 7, Salt Lake City, Utah.
- MUSSER, R. J. 1960. Dragonflies from Green River, in "Ecological study of the flora and fauna of Flaming Gorge Reservoir Basin, Utah and Wyoming," Angus Woodbury *et al.* Univ. of Utah Anthro. Papers, No. 48, Upper Colorado River Series, no. 3, Salt Lake City, Utah, in press.
- NEEDHAM, C. J. and H. B. HEYWOOD. 1929. A Handbook of the Dragonflies of North America. Springfield, Ill., pp. 1-378.
- NEEDHAM, C. J. and M. J. WESTFALL, JR. 1955. A Manual of the Dragonflies of North America (Anisoptera). Univ. of Calif. Press, Berkeley, pp. 1-615.
- TINKHAM, E. R. 1949. Haunts and habits of the Dragonfly *Oplonaeschna armata*. Ent. News 60: 15-17.

## Review

FOREST AND SHADE TREE ENTOMOLOGY. By Roger F. Anderson. Pp. vii + 428, ill. John Wiley and Sons, Inc., New York, 1960. Price, \$8.50.

This is intended as a text for students of forestry, and as a manual for identification of species by keys, pictures, and descriptions of insects and their work. Section I (92 pages) has three brief chapters on anatomy, physiology, and development, on classification, and on ecology; also chapters on the principles and methods of control. In Section II the individual species are treated, in seven chapters, depending on whether they eat the leaves, the inner bark, wood, etc. Species are described in detail and literature references are given. There are over 300 fine photographs, virtually all original; and numerous practical keys throughout.

This reviewer would prefer an approach that places the *insects* first (not the tree), and studies them order by order. This, he believes, will arouse more interest in the student so that he will enjoy his entomology and come really to understand insect life. He will then not only recognize the common pests, but will be entomologically educated and professionally equipped to act with good entomological sense, and also to recognize new situations that may arise. The usual college student takes rather well to entomology, and could be told, frankly, that forest entomology deals with the insects of importance in forestry. But here, the very first words state (p. 3, in caps) that it "deals with the protection of trees . . ." and then, a little farther along, the news is broken gently that it will be necessary to learn something of insects—almost as if this were an unfortunate circumstance, as if the entomologist were somehow apologizing. Is this approach, common to economic texts of past decades, really still necessary?

As to the book, the first three chapters especially suffer from lack of critical reading, and lack of ordinary care in editing and proof reading for which the publisher is largely responsible.—  
R. G. SCHMIEDER.

## EXCHANGES

This column is intended only for wants and exchanges, not for advertisements of goods for sale or services rendered. Notices not exceeding three lines free to subscribers.

These notices are continued as long as our limited space will allow; the new ones are added at the end of the column, and, only when necessary those at the top (being longest in) are discontinued.

---

**Butterflies.** Wish to exchange specimens for Japanese species. Please write to Ichiro Nakamura (Boy, age 16), 26 Aza-Nichiyama Obayashi Takarazuka-shi, Hyogo-Ken, Japan.

**Phasmidae** of nearctic area desired alive. Purchase or trade, drawing on large stock of major orders, worldwide. Domminck J. Pirone, Dept. Entomology, Cornell University, Ithaca, N. Y.

**Nitidulidae and Rhizophagidae** wanted in exchange for European beetles of all families. O. Marek, Zámberk 797, Czechoslovakia.

**Wanted and Needed.** We are compiling a history of entomology, and particularly, at present, of the amateur insect clubs that flourished 50 to 75 years ago. Will you who have knowledge of such early clubs or societies advise me, giving facts on the time of existence, members, etc., which you may have. J. J. Davis, Dept. of Entomology, Purdue University, Lafayette, Indiana.

**Cockroaches (Blattoidea)** of Japan, Okinawa, Formosa (Taiwan), and the Philippines are being studied in cooperation with Dr. K. Princis. Loans of specimens from that area are desired. A. B. Gurney, U. S. National Museum, Washington 25, D. C.

**Orthoptera. Gryllinae** (except domestic sp.) and **Pyrgomorphinae** of the world wanted in any quantity for work in morphology, taxonomy, cytology, and experimental biology; dry, or in fluid, or living. Write D. K. Kevan and R. S. Bigelow, Dept. of Entomology, McGill University, Macdonald College, Quebec, Canada.



# Important Mosquito Works

**MOSQUITO ATLAS. Part I.** The Nearctic Anopheles, important malarial vectors of the Americas, and *Aedes aegypti* and *Culex quinquefasciata*

**MOSQUITO ATLAS. Part II.** The more important malaria vectors of the Old World: Europe, Asia, Africa and South Pacific region

By Edward S. Ross and H. Radclyffe Roberts

Price, 60 cents each (U. S. Currency) with order, postpaid within the United States; 65 cents, foreign.

---

## KEYS TO THE ANOPHELINE MOSQUITOES OF THE WORLD

With notes on their Identification, Distribution, Biology and Relation to Malaria. By Paul F. Russell, Lloyd E. Rozeboom and Alan Stone

Mailed on receipt of price, \$2.00 U. S. Currency. Foreign Delivery \$2.10.

---

For sale by the American Entomological Society, 1900 Race Street, Philadelphia 3, Pa., U. S. A.

---

## Just Published

### New Classified Price Lists

Available separates from the TRANSACTIONS OF THE AMERICAN ENTOMOLOGICAL SOCIETY and ENTOMOLOGICAL NEWS, and all titles of the Society's MEMOIRS have been catalogued by author in twelve special price lists in the following categories:

Coleoptera  
Diptera  
Hemiptera  
Hymenoptera  
Lepidoptera  
Memoirs

Neuroptera and Smaller Orders  
Odonata  
Orthoptera-Dermoptera  
Arachnida and Other Classes  
Bibliography-Biography  
General

Lists will be mailed free upon request. Please state specifically which list or lists you require.

**The American Entomological Society**  
1900 RACE STREET  
PHILADELPHIA 3, PENNSYLVANIA

Just Published

# MEMOIRS OF THE AMERICAN ENTOMOLOGICAL SOCIETY

Number 17

## A TAXONOMIC STUDY OF THE MILLIPED FAMILY SPIROBOLIDAE (DIPLOPODA: SPIROBOLIDA)

By William T. Keeton

147 pages of text, 37 tables, 2 maps, 18 plates,  
table of contents and index

Spirobolid millipeds are probably the most widely known Diplopoda in the United States, being used in many college courses; yet the family has been little studied. This monograph brings together existing knowledge of the group for the first time, and adds much new information gained from critical study of series. The taxonomic history of the family is outlined. External morphology is briefly treated, with emphasis on characters utilized in classification. A summary of current knowledge of life histories is included. The family is redefined, and each genus and species is treated in detail. Particular attention is given to variation and distribution, both of which become more meaningful biologically as a result of synonymizing many species names. Possible phylogenetic relationships of the genera are discussed, and keys to all taxa are provided, with most diagnostic characters illustrated in 18 plates or summarized in 37 tables.

Price \$5.50

---

THE AMERICAN ENTOMOLOGICAL  
SOCIETY

1900 Race Street, Philadelphia 3, Penna., U.S.A.

# ENTOMOLOGICAL NEWS

MARCH 1961

Vol. LXXII

No. 3

---

## CONTENTS

- Scott—Collembola of New Mexico. III. Onychiurinae . . . . . 57
- Svihla—The larva of *Epiophlebia laidlawi* . . . . . 66
- Crabill—Catalogue of the Schendylinae (continued) . . . . . 67
- Krombein—Insect visitors of mat euphorbia . . . . . 80

---

PUBLISHED MONTHLY, EXCEPT AUGUST AND SEPTEMBER, BY  
THE AMERICAN ENTOMOLOGICAL SOCIETY  
PRINCE AND LEMON STS., LANCASTER, PA.  
AND  
1900 RACE STREET, PHILADELPHIA 3, PA.

---

Subscription, per yearly volume of ten numbers: \$5.00 domestic; \$5.30 foreign; \$5.15 Canada.  
Second-class postage paid at Lancaster, Pa.

DIV. 1251  
U.S. NATL. ARCH.

# ENTOMOLOGICAL NEWS

---

ENTOMOLOGICAL NEWS is published monthly, excepting August and September, by The American Entomological Society at Prince and Lemon Sts., Lancaster, Pa., and the Academy of Natural Sciences, 1900 Race Street, Philadelphia 3, Pa., U. S. A.

PHILIP P. CALVERT, Editor Emeritus. R. G. SCHMIEDER, Editor. Editorial Staff: H. J. GRANT, JR., E. J. F. MARX, M. E. PHILLIPS, and J. A. G. REHN.

**SUBSCRIPTIONS:** Communications and remittances to be addressed to Entomological News, 1900 Race Street, Philadelphia 3, Pa.

Prices per yearly volume of 10 numbers.

Private subscriptions, for personal use: in the United States, \$5.00; Canada, \$5.15; other countries, \$5.30.

Institutional subscriptions, for libraries, laboratories, etc.: in the United States, \$6.00; Canada, \$6.15; other countries, \$6.30.

**ADVERTISEMENTS:** Rate schedules available from the editor.

**MANUSCRIPTS** and all communications concerning same should be addressed to R. G. Schmieder, Zoological Laboratory, University of Pennsylvania, Philadelphia 4, Pa.

The receipt of all papers will be acknowledged and, if accepted, they will be published as soon as possible. Articles longer than eight printed pages may be published in two or more installments, unless the author is willing to pay the cost of a sufficient number of additional pages in any one issue to enable such an article to appear without division.

**ILLUSTRATIONS:** Authors will be charged as follows: For text-figures, the cost of engraving; for insert plates (on glossy stock), the cost of engraving plus printing. Size limit, when printed, 4 × 6 inches. All blocks will be sent to authors after printing.

**TABLES:** The cost of setting tables will be charged to authors.

**SEPARATA:** Members of the American Entomological Society may elect to receive, gratis, 25 offprints of their contributions. These will be "run-off-form," without removal of extraneous matter.

Those members desiring more than 25 separates, and all non-members, will receive no gratis copies. They must obtain all their separates (as reprints, with extraneous matter removed) from the printer at the prices quoted below. Authors must place their order for such separates with the editor at the time of submitting manuscripts, or when returning proof.

Copies	1-4 pp.	5-8 pp.	9-12 pp.	Covers
50	\$4.35	\$6.96	\$10.88	\$4.74
100	5.21	8.26	13.05	6.48
Add'l 100	1.74	2.60	4.33	3.48

Plates printed one side: First 50, \$3.47; Additional 100's, \$2.61.

Transportation charges will be extra.

# ENTOMOLOGICAL NEWS

VOL. LXXII

MARCH, 1961

No. 3

## The Collembola of New Mexico. III. Onychiurinae<sup>1, 2</sup>

By HAROLD GEORGE SCOTT<sup>3</sup>

Eleven species of springtail insects are recorded in this part. None has been reported previously from New Mexico. The taxonomy of this subfamily has been badly confused. However, under the impetus of the controversial work of Bagnall (1949), remarkable clarification has been achieved in recent years (Stach, 1954; Salmon, 1959). Specimens will be deposited with the Academy of Natural Sciences, Philadelphia, Pennsylvania.

### Subfamily ONYCHIURINAE Börner, 1901

Pseudocelli present; scales absent; mouthparts chewing; head prognathous; distal antennal segments not annulate; eyes absent; body segments not ankylosed; furcula present or absent, when present not reaching collophore.

### KEY TO WORLD GENERA OF ONYCHIURINAE

1. Furcula and body pigment well developed.....2  
Furcula absent or reduced; body generally unpigmented...4
2. Median shaft of maxilla well developed, toothed; Ant III sense organ with more than 5 papillae arranged in 2-3 transverse rows; adults 5-7 mm. long.....3

<sup>1</sup> A portion of a dissertation submitted to the Graduate Faculty of the University of New Mexico, Albuquerque, in partial fulfillment of the requirements for the Degree of Doctor of Philosophy.

<sup>2</sup> Part II, Ent. News, 71(7) : 183-191.

<sup>3</sup> Training Branch, Communicable Disease Center, Bureau of State Services, Public Health Service, U. S. Department of Health, Education, and Welfare, Atlanta, Georgia.

- Median shaft of maxilla absent; Ant III sense organ with 4 papillae in 1 transverse row; adults 0.6–1.5 mm. long (Japan).....**Lophognathella** Börner, 1909
3. Abd V and VI ankylosed dorsally; antennal bases with 3 + 3 pseudocelli; Ant IV tip with 0 small papillae (Japan).....**Tetodontophora** Reuter, 1882
- Abd V and VI not ankylosed dorsally; antennal bases with 1 + 1 pseudocelli; Ant IV tip with 6 small papillae (Japan).....**Homaloproctus** Börner, 1909
4. Clubs of Ant III sense organ bent toward each other (or, if straight, not concealed behind an integumentary fold); unguiculus absent or greatly reduced.....5
- Clubs of Ant III sense organ straight or curved but not bent toward each other; unguiculus present (Cosmopolitan)...  
.....**Onychiurus** Gervais, 1944 (*sensu lato*)
5. Body slender; postantennal organ present (Cosmopolitan)...  
.....**Tullbergia** Lubbock, 1876 (*sensu lato*)
- Body stout; postantennal organ absent.....**Hoffia** gen. nov.

#### GENUS **ONYCHIURUS** GERVAIS, 1844

DIAGNOSTIC CHARACTERISTICS. Body stout; head broad; clubs of Ant III sense organ not bent toward each other; unguiculus present. Salmon (1959) considers this group to represent 12 separate genera. In the present paper Salmon's genera are considered subgenera of *Onychiurus* (see fig. 1).

#### KEY TO NEARCTIC SPECIES OF **ONYCHIURUS**

1. Postantennal organ present.....2  
Postantennal organ absent.....  
.....(*Metonychiurus*) **michelbacheri** (Bagnall, 1947)
2. Postantennal organ of simple vesicles.....3  
Postantennal organ of compound vesicles.....15
3. Postantennal organ with 3–5 vesicles arranged in rosette...  
.....(*Arcaphorura*) **groenlandicus** (Tullberg, 1876)  
Postantennal organ elongate with more than 5 vesicles arranged in rows.....4
4. Vesicles of postantennal organ sub-parallel to long axis of organ (*Hymenaphorura*).....5  
Vesicles of postantennal organ at right angles to long axis of organ.....9
5. One pseudocellus on antennal base.....6  
Two or more pseudocelli on antennal base.....8

6. Clubs of Ant III sense organ mushroom-like, coarsely granulated.....**cocklei** (Folsom, 1908)  
Clubs of Ant III sense organ globular, mulberry or cone-like.....7
7. Vesicles of postantennal organ mostly simple.....  
.....**similis** Folsom, 1917  
Vesicles of postantennal organ mostly bilobed or kidney-like.....**irregularis** Chamberlain, 1943
8. Antennal base with 2-3 pseudocelli.. **subtenuis** Folsom, 1917  
Antennal base with 4 pseudocelli...**magninus** Wray, 1950a
9. Clubs of Ant III sense organ smooth (*Handchiniella*)...10  
Clubs of Ant III sense organ granulated (*Protaphorura*)...13
10. Unguiculus about one-half unguis in length.....  
.....**parvicornis** Mills, 1934  
Unguiculus subequal to or longer than unguis in length..11
11. Unguiculus subequal to unguis in length.....  
.....**encarpatus** Denis, 1931  
Unguiculus longer than unguis.....12
12. Antennal base with 4 pseudocelli.....  
.....**octopunctatus** (Tullberg, 1876)  
Antennal base with 6 (rarely 5) pseudocelli.....  
.....**duodecimpunctatus** Folsom, 1919
13. Antennal base with 2 pseudocelli.....  
.....**litoreus** Folsom, 1917  
Antennal base with 3 pseudocelli.....14
14. Unguiculus subequal to unguis in length.....  
.....**armatus** (Tullberg, 1869)  
Unguiculus about one-half unguis in length.....  
.....**pseudarmatus** Folsom, 1917
15. Vesicles of postantennal organ, though tuberculated, clearly visible as separate structures.....16  
Vesicles of postantennal organ not visible as separate structures, postantennal organ a mass of small tubercles...22
16. Clubs of Ant III sense organ undifferentiated, smooth (*Onychiurus*).....17  
Clubs of Ant III sense organ differentiated, usually granulated (*Paronychiurus*).....20
17. Anal spines present.....**wilchi** Wray, 1950b  
Anal spines absent.....18
18. Clubs of Ant III sense organ straight, ovoid, usually slightly bifurcated at tip.....**justi** Denis, 1938  
Clubs of Ant III sense organ curved, cylindrical, rounded at tip.....19

19. Unguiculus with basal lamella.....  
 ..... **pseudofimetarius** Folsom, 1917  
 Unguiculus without basal lamella.....  
 ..... **fimetarius** (Linnaeus, 1767)
20. Hind margin of head without pseudocelli.....21  
 Hind margin of head with 4-6 pseudocelli.....  
 ..... **oreadis** Mills, 1935
21. Anal spines to unguis as 1:2, papillae contiguous.....  
 ..... **ramosus** Folsom, 1917  
 Anal spines to unguis as 3:4, papillae separated.....  
 ..... **millsi** Chamberlain, 1943
22. Clubs of Ant III sense organ smooth.....  
 ..... (*Psyllaphorura*) **obesus** Mills, 1934  
 Clubs of Ant III sense organ granulated or papillated.....  
 ..... (*Pseudonychiurus*) **dentatus** (Folsom, 1902)

I have been unable to determine the status of two other species recorded from North America; *Onychiurus ambulandinermis* Denis, 1929, and *Onychiurus californicus* Coleman, 1941. The following species are recorded from New Mexico:

**Onychiurus (Onychiurus) fimetarius** (Linnaeus, 1767)

NEW MEXICO RECORDS. Berlese, rotten fir log, 8,300 ft., Tejano Canyon, Sandia Mts., Bernalillo Co., 3-xi-1950.

DISTRIBUTION. N. M., Europe. As discussed in Stach (1954, pp. 173-179), this species has been regarded as cosmopolitan, but probably most determinations are in error. Therefore, re-evaluation of all prior records is required to establish distribution.

**Onychiurus (Psyllaphorura) obesus** Mills, 1934.

NEW MEXICO RECORD. Berlese, fir-aspen litter, 8,600 ft., NE of Valdez on Twining Road, Taos Co., 15-vii-1953.

DISTRIBUTION. Iowa, N. M.

**Onychiurus (Onychiurus) justii** Denis, 1938.

NEW MEXICO RECORD. Berlese, oak litter, 7,400 ft., Doc. Long's, Sandia Mts., Bernalillo Co., 29-v-1951.

DISTRIBUTION. Cal., Fla., Mass., N. M., Penna., Australasia.



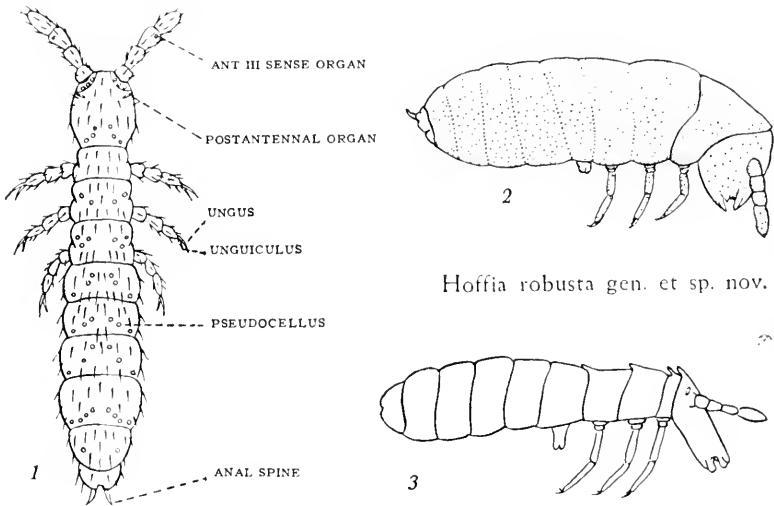

*Hoffia robusta* gen. et sp. nov.

*Onychiurus armatus* (Tullberg)

*Tullbergia neomexicana* sp. nov.

FIG. 1. *Onychiurus armatus* (Tullberg, 1869) with key structures labelled. FIG. 2. *Hoffia robusta* gen. et sp. nov., lateral view of holotype. FIG. 3. *Tullbergia neomexicana* sp. nov., lateral view of holotype.

***Onychiurus* (*Paronychiurus*) *oreadis* Mills, 1935.**

NEW MEXICO RECORD. Berlese, fir-aspen litter, 9,200 ft., Sandia Mts., Bernalillo Co., 14-vii-1951.

DISTRIBUTION. N. M., Utah, Wash.

***Onychiurus* (*Handschiniella*) *parvicornis* Mills, 1934.**

NEW MEXICO RECORDS. Berlese, rotten fir stump, 8,900 ft., Bear Trap Canyon, SW of Magdalena, Socorro Co., 12-ix-1954.

DISTRIBUTION. Iowa, N. M.

***Onychiurus* (*Onychiurus*) *pseudofimetarius* Folsom, 1917.**

NEW MEXICO RECORDS. Berleses of (1) juniper litter, 7,600 ft., N. of pumice mine near Grants, Valencia Co., 22-vii-1953; (2) aspen litter, 8,700 ft., Sandia Mts., Bernalillo Co., no date

recorded; (3) aspen-fir litter, 9,700 ft., W of Vallecitos on Canjilon Road, Rio Arriba Co., 13-viii-1953.

**Onychiurus (Hymenaphorura) similis** Folsom, 1917.

NEW MEXICO RECORD. Berlese, rich aspen litter, 10,800 ft., Aspen Hill, near Santa Fe Ski Run, Santa Fe Co., 11-viii-1953.

DISTRIBUTION. Ill., N. M.

**Onychiurus (Hymenaphorura) subtenuis** Folsom, 1917.

NEW MEXICO RECORDS. Berleses of (1) juniper litter, 7,500 ft., S of Santa Fe, Santa Fe Co., 5-ix-1952; (2) rotten fir log, 8,300 ft., Tejano Canyon, Sandia Mts., Bernalillo Co., 3-xi-1950; (3) aspen litter, 8,700 ft., Sandia Mts., Bernalillo Co., no date recorded; (4) aspen litter, 10,000 ft., Santa Fe Ski Run, Santa Fe Co., 12-x-1952; and (5) fir litter, 10,000 ft., along Crest Drive, Sandia Mts., Bernalillo Co., 8-vii-1950.

DISTRIBUTION. Ill., Iowa, Mo., N. M., N. Y., N. C., Pa., Utah, Ontario.

**Onychiurus (Onychiurus) wilchi** Wray, 1950b.

NEW MEXICO RECORDS. Berleses of (1) aspen-spruce-fir litter, 9,250 ft., Holman Pass, NW of Holman, Mora Co., 9-vii-1953; and (2) aspen-fir litter, 10,600 ft., near crest, Sandia Mts., Bernalillo Co., 22-ix-1951.

GENUS **HOFFIA** gen. nov.

TYPE SPECIES. *Hoffia robusta* gen. et sp. nov. Figure 2.

DESCRIPTION. Body elongate, not subglobose, generally unpigmented; prothorax setaceous, well developed; pseudocelli present; head prognathous; furcula absent; mouthparts chewing; eyes absent; unguiculus and postantennal organ absent; clubs of Ant III sense organ bent toward each other; anal spines 2; body very stout, head narrow.

DISCUSSION. This genus is close to *Tullbergia*, but species of *Tullbergia* are slender with the body tapering gradually at each end, and always have postantennal organs. It is with pleasure that I name the genus for Dr. C. Clayton Hoff, Pro-

fessor of Biology, University of New Mexico, whose diligent collecting made this study possible.

**Hoffia robusta** gen. et sp. nov. Figure 2

TYPE LOCALITY: Holotype and 3 paratypes from 1 mi. N of pumice mine, N of Grants, Valencia Co., N. M.; field Berlese, Pinyon litter, 7,500 ft., 20-x-1951. Type specimens will be deposited with the Academy of Natural Sciences, Philadelphia, Pa.

DESCRIPTION. Body elongate, not subglobose, generally unpigmented; body stout; head narrow; segmentation distinct, without ankylosis; integument minutely tuberculate; white; clothed by moderately long setae; pseudocelli present, difficult to perceive; head prognathous; antenna to head at 3:4; ratio of antennal segments approximately 7:5:6:14; clubs of Ant III sense organ bent toward each other; postantennal organ and eyes absent; mouthparts chewing; prothorax setaceous, well developed; unguiculus absent; unguis long, with one tooth; tenent hairs and furcula absent; anus terminal; anal spines 2, strongly curved,  $1\frac{1}{2}$  times as long as unguis III; adult length about 0.9 mm.

GENUS **TULLBERGIA** LUBBOCK, 1876

DIAGNOSTIC CHARACTERISTICS. Body slender, unpigmented; head narrow; postantennal organ with many tubercles; clubs of Ant III sense organ bent toward each other; unguiculus usually absent or greatly reduced; anal spines 0-4; furcula absent.

KEY TO NEARCTIC SPECIES OF *TULLBERGIA*

1. Anal spines present.....2  
    Anal spines absent.....**neomexicana** sp. nov.
2. Abd VI with medio-ventral process.....3  
    Abd VI without medio-ventral process.....4
3. Vesicles of postantennal organ simple.....  
    .....**knowltoni** Wray, 1950  
    Vesicles of postantennal organ horse-shoe shaped.....  
    .....**incisa** Bonet, 1944

4. Abd VI tergite with pits, ridges, or warts.....5  
Abd VI tergite without pits, ridges, or warts.....7
5. Pair of tubercles or tuberculated areas anterior to anal  
spines on Abd VI.....**tuberosa** Bonet, 1944  
Semicircular ridged pits anterior to anal spines on Abd  
VI.....6
6. Postantennal vesicles in 2 transverse rows.....  
.....**krausbaueri** Borner, 1901  
Postantennal vesicles in 4 irregular transverse rows.....  
.....**foveata** Bonet, 1944
7. Postantennal vesicles in 2 transverse rows.....8  
Postantennal vesicles in 4 transverse rows.....9
8. Unguiculus bristle-like.....**granulata** Mills, 1934  
Unguiculus absent.....**clavata** Mills, 1934
9. Unguiculus bristle-like.....10  
Unguiculus absent.....**mexicana** Handschin, 1928
10. Ant III sense organ with club-like accessory hair.....  
.....**collis** Bacon, 1914  
Ant III sense organ without club-like accessory hair.....  
.....**baconae** (Bagnall, 1947)

Only one species of *Tullbergia* is recorded from New Mexico.

#### ***Tullbergia neomexicana* sp. nov.** Figure 3

**TYPE LOCALITY.** Holotype and 4 paratypes from foothills, Sandia Mts., Bernalillo Co., N. M.; Berlese of oak litter, 6,400 ft., 5-ix-1951. Type specimens will be deposited with the Academy of Natural Sciences, Philadelphia, Pa.

**DESCRIPTION.** Body elongate, slender; segmentation distinct, without ankylosis; integument smooth, white; clothed with moderately long setae; scales absent; pseudocelli present; head narrow, prognathous; antenna shorter than head; clubs of Ant III sense organ bent toward each other; postantennal organ with numerous simple tubercles; eyes absent; mouthparts chewing; pronotum setaceous; tibiotarsus without distal subsegment; claws tunicate; unguiculus to unguis as 3:8; tenet hairs absent; unguis and unguiculus without teeth; furcula absent; anus terminal; anal spines absent; adult length about 0.6 mm.

**DISCUSSION.** This species is distinguished from other members of the genus by the well-developed unguiculus and absence of anal spines.

NEW MEXICO RECORDS. Type collection plus Berleses of (1) oak litter, and (2) aspen litter, 8,700 ft., no date recorded, Sandia Mts., Bernalillo Co.

## SUMMARY

Record is made of 9 species of *Onychiurus*, *Hoffia robusta* gen. et sp. nov., and *Tullbergia neomexicana* sp. nov., from New Mexico. Ecological data are presented for all 11 species. Keys to world genera of Onychiurinae and to Nearctic species of *Onychiurus* and *Tullbergia* are included.

## REFERENCES CITED

- BACON, G. 1914. Jour. Ent. Zool. 6: 84-85.  
 BAGNALL, R. S. 1947. Ann. Mag. Nat. Hist., ser. II, 14.  
 BONET, F. 1944. Rev. Soc. Mex. Hist. Nat. 5: 51-72.  
 BORNER, C. 1901. Zool. Anz., 24: 332-345.  
 ——. 1909. Sitz. Ges. naturf. Freunde Berlin 2: 99-135.  
 CHAMBERLAIN, R. 1943. Great Basin Nat. 4: 39-48.  
 COLEMAN, T. 1941. Jour. Ent. Zool. 33: 1-11.  
 DENIS, J. 1929. Boll. Inst. Agr. Portici 22: 160-180, 305-320.  
 ——. 1931. Boll. Lab. Inst. Gen. Agr. Portici 25: 69-170.  
 ——. 1938. Boll. Adriatica Sci. Nat. Trieste 36: 95-165.  
 FOLSOM, J. W. 1902. Proc. Washington Acad. Sci. 4: 87-116.  
 ——. 1917. Proc. U. S. Natl. Mus. 53: 637-659.  
 ——. 1919. Bull. American Mus. Nat. Hist. 41: 271-303.  
 GERVAIS, P. 1844. In: Walckenaer's Hist. Nat. Insectes apteres 3: 377-456.  
 HANDSCHIN, E. 1928. Jour. Linnaean Soc. London, Zool. 36: 533-552.  
 LINNAEUS, C. 1767. Systema naturae. Ed. 12 (revised), Holmiae, 3 vol., 1327 + 36 pp.  
 LUBBOCK, J. 1876. Ann. Mag. Nat. Hist., ser. 4, 18: 324.  
 MILLS, H. B. 1934. A monograph of the Collembola of Iowa. Amcs: Collegiate Press, xii + 143 pp.  
 ——. 1935. Bull. Brooklyn Ent. Soc. 30: 133-139.  
 REUTER, O. M. 1882. Sitz. Akad. Wiss. Wein 86(1): 184.  
 SALMON, J. T. 1959. Trans. Royal Ent. Soc. London 111(6): 119-156.  
 STACH, J. 1954. The apterygotan fauna of Poland. V. Onychiuridae. Polish Acad. Sci., Cracow, ii + 277 pp.  
 TULLBERG, T. 1869. Akad. Afhandl. Upsala, vol. of 1869: 1-20.  
 ——. 1876. Ofv. K. Vet.-Akad. Forhandl. 33(5): 23-42.  
 WRAY, D. L. 1950a. Bull. Brooklyn Ent. Soc. 45(3): 91-95.  
 ——. 1950b. Psyche, 57(3): 95-101.

## Another Record of the Larva of *Epiophlebia laidlawi* Tillyard, (Odonata: Anisozygoptera).

By ARTHUR SVIHLA, Ford Foundation—University of Florida—  
University of Mandalay Program, Mandalay, Burma

At the present time only two species of *Epiophlebia* of the sub-order Anisozygoptera are known, *Epiophlebia superstes* Selys which occurs in Japan and *Epiophlebia laidlawi* Tillyard from the Himalayas.

In 1921 Tillyard (Rec. Ind. Mus. 22: 93–107) described the Himalayan form as *laidlawi* from a single nymph which had been collected in the Darjeeling district at an elevation of 7000 feet by Dr. S. Kemp from a rapidly flowing stream between Ghoom\* and Sonada. Later searches by specialists for both adults and larvae were unsuccessful until Asahina in March 1958 (Tombo 1(1): 1–2) first rediscovered the nymph. He collected a series from a stream between Ghum and Rangbhul. His collections consisted of one ultimate male instar (the first for this species); one penultimate female (the type of *E. laidlawi* was a penultimate male); four tertiultimate larvae; and one quartultimate larva.

Dr. Asahina very kindly told me where he had collected these specimens, and, on October 9, 1960, I visited what I believed to be the same site and collected three ultimate female larvae (the first for this species) and two larvae much younger than the youngest in Dr. Asahina's collection.

For the benefit of future collectors the site of my collection may be described as the rocky stream which passes under the Siliguri-Darjeeling railroad track near Rangbhul at marker number 469. Above the bridge there is a short stretch of rapidly flowing water about 100 feet long where the larvae were found. This is blocked up-stream by a waterfall. Below the bridge and highway is another waterfall (artificially made) but the stream persists and continues to lower levels. There is every reason to believe that larvae occur above and below the two waterfalls mentioned. Lack of time prevented my further search.

\* Ghoom is variously spelled as Ghum and Ghun. At present the preferred spelling is Ghum.

No adults of this species were seen on this date. In fact no dragon-flies of any sort were seen in flight in this area on this visit. The imago still remains unknown.

I agree with Dr. Asahina that the habitats of the nymphs of the two species of *Epiophlebia* are quite similar.

---

## A Catalogue of the Schendylinae of North America including Mexico, with a Generic Key and Proposal of a New Simoporus (Chilopoda: Geophilomorpha: Schendylinae)

By R. E. CRABILL, JR., Smithsonian Institution,  
Washington, D. C.

(Continued from p. 36)

### CATALOGUE OF THE SCHENDYLINES PRESENTLY KNOWN FROM MEXICO, THE CONTINENTAL UNITED STATES, AND CANADA

The following catalogue of genera and species is believed to include reference to all schendylines now known to occur in, or to have been reported from, the American continent from Alaska south through Mexico. The forms of continental islands and archipelagos are included, but those of the Caribbean islands proper, of most of Central America, and of all of South America are not, unless, of course, they also occur within the area under consideration.

For each genus and species a summary synonymy is presented together with literary citations. The type-species of each genus is identified, and the method of fixation is parenthesized thereafter. Ranges are summarized, and in some instances notes on identity or generic assignment are appended. In the cases of non-monotypic genera, and whenever possible, selected, useful keys to species are recommended through reference to their literary source and author.

The reader's attention is directed to the following keys to schendylid (or schendyline) genera. (1) Cook, 1904, p. 76:

key to known schendyline genera including *Holitys*, q.v. (2) Broelemann and Ribaut, 1912, p. 97: key to known schendyline genera; especially recommended for its exhaustively detailed figures and verbal descriptions; but see note under *Pectiniunguis* below. (3) Attems, 1929, p. 58: key to known genera; remains the most useful of keys for world fauna but somewhat outdated. (4) Chamberlin, 1943, p. 12: key to most genera represented in Mexico and Central America. (5) Chamberlin, 1947b, p. 147: key to most genera represented in all of the Americas, with some omissions, e.g., *Brachyschendyla* and *Hydroschendyla*. (6) Crabill, 1953, p. 94: key to northeastern North American genera and species.

#### APUNGUIS Chamberlin

*Apunguis* Chamberlin, 1947c, p. 260.

Type-species: *Apunguis prosoicus* Chamberlin, 1947. (Original designation and monotypic).

Range: Known only from the locality of the type-species.

#### *Apunguis prosoicus* Chamberlin

*Apunguis prosoicus*, Chamberlin, 1947c, p. 2660.

Type-locality: Texas: Eagle Pass; intercepted on fruit from Mexico.

Range: Known only from type-locality.

#### ESCARYUS Cook and Collins

*Escaryus* Cook and Collins, 1891, p. 391.

Type-species: *Escaryus phyllophilus* Cook and Collins, 1891 [= *Escaryus urbicus* (Meinert), 1886]. (Subsequent designation of Cook, 1895, p. 71).

Range: Temperate to arctic North America, eastern and central Asia.

Selected keys: Cook, 1904, p. 76: to known species.<sup>7</sup> Attems, 1929, p. 95: to known species. Chamberlin, 1946a, p. 178: to

<sup>7</sup> The original publication of Cook's well-known species *Escaryus albus* appeared in this publication and is included in the key. *E. albus*, a stubborn *Poltergeist*, has been mentioned faithfully by all persons who have treated the Alaskan fauna, even though no one has succeeded in uncover-



species of Alaska and adjacent Siberia. Chamberlin, 1947a, p. 37: presumably to known species, but some are omitted. Crabill, 1953, p. 96: to species of northeastern North America.

**Escaryus delus** Chamberlin

?*Escaryus ethopus* (Chamberlin), 1920, p. 43.

*Escaryus delus* Chamberlin, 1946a, p. 178.

Type-locality: Alaska: Circle City, Fairbanks.

Range: Known only from the two type-localities.

**Escaryus ethopus** (Chamberlin)

*Geophilus ethopus* Chamberlin, 1920, p. 43.

*Escaryus ethopus* (Chamberlin), [New combination].

Type-locality: Alaska: Iditarod Island.

Range: Known only from the type-locality.

Notes: This species, originally placed in the wrong genus and family, is clearly both a schendylid and a member of *Escaryus*; this is proved unquestionably by its distinctive mouthparts which had never been dissected before my recent study of the holotype at Harvard. Its characteristics do not seem immediately suggestive of any described *Escaryus*, although in some features one could perhaps find grounds for suspecting an affinity with *E. delus* Chamberlin, *q.v.*

The following diagnostic characteristics, drawn from a recent study of the *ethopus* holotype, were not mentioned in Professor Chamberlin's original description of the species. In a report now in progress, wherein the whole Alaskan chilopod fauna will be treated, a full and detailed description of *ethopus* will be presented. Paraclypeal sutures of the clypeus present only anteriorly as fragments, totally absent over two-thirds of their hypothetical posterior course; distinct plagulae absent; clypeal areas

---

ing additional specimens. The explanation for this is simple and almost incredible. Having discovered the two Cook cotypes of *albus*, after they had been lost for many years, I found them to be juvenile specimens of some species of *Strigamia*, hence not even members of Schendylidae! Their poor state of preservation and immaturity, however, preclude a specific assignment within *Strigamia* at this time. At the same time, there can be no doubt whatever about the genus to which they are properly assignable.

absent. Labrum with about 25 teeth, these occupying the full width of the midlabral arch. First maxillae: with robust, coarsely squamulate telopodite lappets, these reach about  $\frac{2}{3}$  the length of the telopodites: coxosternal lappets essentially absent, being extremely low and broad. Second maxillae: telopodite claw very robust, apically somewhat bent, with coarsely, strongly pectinate edges. Prehensors: femuroid and tibiod as well as tarsungula (unlike eastern North American species) totally without denticles; trochanteroprefemur with a low, very small denticle. Ultimate pedal segment: pretergite laterally not suturate; tergite much wider than long; sternite very long and nearly perfectly rectangular, midlongitudinally shallowly sulcate; coxopleura antero-posteriorly very long, moderately inflated, pierced by numerous small to large pores, many of these irregularly shaped; legs (of ♂) greatly swollen, somewhat flattened dorso-ventrally, the unguiform pretarsi missing. Anal pores present, large.

**Escaryus liber** Cook and Collins

*Escaryus liber* Cook and Collins, 1891, p. 394.

Type-locality: New York: Kirkville.

Range: New York, Maryland, District of Columbia, Ohio.

Probably distributed throughout much of northeastern North America.

**Escaryus missouriensis** Chamberlin

*Escaryus missouriensis* Chamberlin, 1942, p. 185.

Type-locality: Missouri: St. Louis Co., 4.3 miles northwest of Glencoe.

Range: Missouri, Indiana, Illinois. Probably is widespread in the midwestern United States.

**Escaryus monticolens** Chamberlin

*Escaryus monticolens* Chamberlin, 1947a, p. 37.

Type-locality: Utah, Mill Creek Canyon.

Range: Known only from the type-locality.

**Escaryus paucipes** Chamberlin

*Escaryus paucipes* Chamberlin, 1946a, p. 179.

Type-locality: Alaska: Haines.

Range: Known only from the type-locality.

**Escaryus urbicus** (Meinert)

*Geophilus urbicus* Meinert, 1886, p. 218.

*Escaryus phyllophilus* Cook and Collins, 1891, p. 392.

*Escaryus urbicus* (Meinert), -Bailey, 1928, p. 44.

Type-locality: Massachusetts: Cambridge.

Range: Northeastern North America. Probably extends far southward at higher elevations in the Appalachians.

**HOLITYS** Cook

*Holitys* Cook, 1899, p. 304.

?*Mexiconyx* Chamberlin, 1922, p. 9.

?*Simoporus* Chamberlin, 1940a, p. 109.

Type-species: *Holitys ncomexicana* Cook, 1899. (Monotypic.)

Range: Known only from the locality of the type-species.

Key: Cook, 1904, p. 76: the only known key including *Holitys*.

Notes: Unfortunately, the information that Cook gave is most fragmentary. Piecing together the information given in the original description with that in his 1904 key, we learn the following about the form. Ultimate pretarsus is present and unguiform; ultimate legs, reportedly of a ♀, are inflated, subdensely setose, have two tarsal articles. The coxopleural gland openings, if present, are concealed. The ultimate pedal sternite is much wider than long. Ventral porefields are present and in shape are circular, in position, median. The genus is claimed to be like *Pectiniunguis* in some respects (in which?). The holotype is a ♀ 15 mm long and has 45 pedal segments.

Thus, we know nothing definite about the species' mouthparts, and all we can say about the coxopleural glandular condition is that if a pore is or if pores are present, then they are concealed. Clearly it is impossible on the basis of such evidence alone to come to any even reasonably confident decision anent the disposition of the Cook name. At the same time, I believe it is possible to suggest from this evidence, poor and indirect as it is, that it would be very difficult to preclude the possibility that *Holitys* is identical with, or very closely related to, *Simoporus* or *Mexiconyx*, or both. This is admittedly a reasonable guess; it cannot at the present time be substantiated, the type being unavailable.

**Holityx neomexicana** Cook

*Holityx neomexicana* Cook, 1899, p. 304.

*Holityx neomexicana* Cook. -Attems, 1929, p. 99. ["Ganz ungenügende Diagnose"].

Type-locality: New Mexico: Organ Mountains, Dropping Spring.

Range: Known only from the type-locality.

**MEXICONYX** Chamberlin

?*Holityx* Cook, 1899, p. 304

*Mexiconyx* Chamberlin, 1922, p. 9.

Type-species: *Mexiconyx hidalgoensis* Chamberlin, 1922.  
(Original designation and monotypic.)

Range: Known only from the locality of the type-species.

Notes: See notes under *Holityx*.

**Mexiconyx hidalgoensis** Chamberlin

*Mexiconyx hidalgoensis* Chamberlin, 1922, p. 9.

Type-locality: Mexico: Hidalgo, Guerrere Mill.

Range: Known only from the type-locality.

**MORUNGUIS** Chamberlin

*Morunguis* Chamberlin, 1943, p. 15.

Type-species: *Morunguis morelus* Chamberlin, 1943. (Original designation and monotypic).

Range: Known only from locality of the type-species.

**Morunguis morelus** Chamberlin

*Morunguis morelus* Chamberlin, 1943, p. 15.

Type-locality: Mexico: Morelos, Parque Nacional de Zempoala.

Range: Known only from the type-locality.

**NESONYX** Chamberlin

*Nesonyx* Chamberlin, 1923, p. 397.

Type-species: *Nesonyx flagellans* Chamberlin, 1923. (Original designation and monotypic.)

Range: Known only from the locality of the type-species.

**Nesonyx flagellans** Chamberlin

*Nesonyx flagellans* Chamberlin, 1923, p. 397.

Type-locality: Mexico: Gulf of California, Georges Island.

**PARUNGUIS** Chamberlin

*Parunguis* Chamberlin, 1941, p. 788.

Type-species: *Parunguis kernensis* Chamberlin, 1941. (Original designation and monotypic.)

Range: Southern and central Mexico, and Texas.

**Parunguis boneti** Chamberlin

*Parunguis boneti* Chamberlin, 1943, p. 13.

Type-locality: Mexico: D.F., Desierto de los Leones, San Rafael.

Range: Known only from the type-locality.

**Parunguis cardenasi** Chamberlin

*Parunguis cardenasi* Chamberlin, 1943, p. 13.

Type-locality: Mexico: D.F., Rio Frio.

Range: Known only from the type-locality.

**Parunguis kernensis** Chamberlin

*Parunguis kernensis* Chamberlin, 1941, p. 788.

Type-locality: California: Kern Co., 4 miles east of Glenville.

Range: Known only from type-locality.

**Parunguis paucipes** Chamberlin

*Parunguis paucipes* Chamberlin, 1943, p. 14.

Type-locality: Mexico: Vera Cruz, Orizaba, Cuesta de Acultzingo, "Monte Bajo."

Range: Known only from type-localities.

**PECTINIUNGUIS** Bollman

*Pectiniunguis* Bollman, 1889, p. 212.

*Adenoschendyla* Broelemann, 1911, p. 192.

*Litoschendyla* Chamberlin, 1923, p. 391. [New synonymy.]

Type-species: *Pectiniunguis americanus* Bollman, 1889, p. 212. (Original designation.)

Range: Coastal southern California and Mexican Lower California; Antilles and South America. Probably widespread on the coasts of tropical and subtropical America.

Selected Keys: Broelemann and Ribaut, 1912, pp. 100, 106: keys to the known species of *Pectiniunguis* and *Adenoschendyla* (= *Pectiniunguis*). Chamberlin, 1914, p. 201: key to species

of *Adenoschendyla*. Attems, 1929, pp. 81, 84: keys to known species.

Notes: For a discussion of my grounds for provisionally uniting *Litoschendyla* and *Pectiniunguis*, the reader is referred to Crabill, 1959, p. 324.

**Pectiniunguis americanus** Bollman

*Pectiniunguis americanus* Bollman, 1889, p. 212.

Type-locality: Mexico: "Gulf of California, Pichiliungue Bay."

The original locality citation of Bollman is in error. The correct rendition is: Mexico, Lower California, *Pichilinqu* Bay.

Range: Strictly speaking, the species is known only from the type-locality; Cook's 1899 report of it from Florida was based upon a misidentification.

Notes: See discussion in Crabill, 1959, p. 324.

**Pectiniunguis amphibius** Chamberlin

*Pectiniunguis amphibius* Chamberlin, 1923, p. 392.

Type-locality: Mexico: Gulf of California, Danzante Island.

Range: Known only from the type-locality.

**Pectiniunguis catalinensis** Chamberlin

*Pectiniunguis catalinensis* Chamberlin, 1941, p. 787.

Type-locality: California: Catalina Island, "near Black Jack."

Range: Known from type-locality only.

**Pectiniunguis halirrhytus** Crabill

*Pectiniunguis halirrhytus* Crabill, 1959, p. •.

Type-locality: Florida: Monroe Co., Big Pine Key.

Range: Florida Keys. Probably ranges widely from southern coastal Florida throughout much or all of the West Indies.

Notes: When Cook reported *americanus* from the Florida Keys in 1899 (p. 305), his records were actually based upon a different species, *halirrhytus*, which he did not identify as such. See discussion in Crabill, 1959, p. 324.

**Pectiniunguis nesiotus** Chamberlin

*Pectiniunguis nesiotus* Chamberlin, 1923, p. 391.

Type-locality: Mexico: Gulf of California, San Esteban Island.

Range: Type-locality only.

**SCHENDYLA** Bergsöe and Meinert

*Schendyla* Borgsöe and Meinert, 1866, p. 103.

Type-species: *Geophilus nemorensis* C. L. Koch, 1836 [= *Schendyla (Schendyla) nemorensis* (C. L. Koch)]. (Monotypic.)

Range: Europe, Asia, North and South America, North Africa.

Selected key: Attems, 1929, p. 59.

**Schendyla nemorensis** (C. L. Koch)

*Geophilus nemorensis* C. L. Koch, 1836, p. •.

*Poabius bistratus* C. L. Koch, 1847, p. 183.

*Linotaenia nemorensis* (C. L. Koch), -Koch, 1863, p. 26.

*Schendyla nemorensis* (C. L. Koch), -Bergsöe and Meinert, 1866, p. 105.

*Geophilus tyrolensis* Meinert, 1870, p. 73.

*Geophilus gracilis* Harger, 1872, p. 18.

Range: Europe, North Africa, North America. Evidently readily transported and easily established; probably occurs widely throughout the temperate Holarctic region through repeated introductions. In the United States *nemorensis* is known to occur in many of the states east of the Mississippi and north of Virginia; elsewhere reports of it have been sporadic. Eventually it will very likely be known to inhabit many, or most, of our states.

**SERRUNGUIS** Chamberlin

*Serrunguis* Chamberlin, 1941, p. 789.

Type-species: *Serrunguis paroicus* Chamberlin, 1941. (Original designation and monotypic.)

Range: Known only from the locality of the type-species.

**Serrunguis paroicus** Chamberlin

*Serrunguis paroicus* Chamberlin, 1941, p. 789.

Type-locality: California: Mountain Springs.

Range: Known only from the type-locality.

**NYCTUNGUIS** Chamberlin

*Nyctunguis* Chamberlin, 1914, p. 201.

Type-species: *Pectiniunguis montereus* Chamberlin, 1904 [= *Nyctunguis montereus* (Chamberlin)]. (Original designation.)

Range: Mexico, California, Tennessee, Texas, Utah, Arizona.

Notes: Despite the assignment of many species to this genus, no key to the species has ever been published. These species, as described, are clearly all quite similar, and, on the basis of their printed descriptions, it is extremely difficult or impossible to identify the majority of them with confidence. This problem is further complicated by the rarity of specimens assignable to *Nyctunguis* in collections. It is probably not too extreme to suggest that nearly all such identified specimens are members of typical series or are holotypes.

***Nyctunguis apachus* Chamberlin**

*Nyctunguis apachus* Chamberlin, 1941, p. 786.

Type-locality: Arizona: 38 miles south of Ajo (♀ holotype);  
20 miles south of Ajo (♀ paratype).

Range: Known only from the two type-localities and from North Sasaba, Arizona.

***Nyctunguis arcochilus* Chamberlin**

*Nyctunguis arcochilus* Chamberlin, 1941, p. 785.

Type-locality: Texas: Laredo.

Range: Known only from the type-locality.

***Nyctunguis auxus* Chamberlin**

*Nyctunguis auxus* Chamberlin, 1941, p. 787.

Type-locality: California: Coyote Wells.

Range: Known only from the type-locality.

***Nyctunguis catalinae* (Chamberlin)**

*Pectiniunguis heathii catalinae* Chamberlin, 1912a, p. 669.

*Nyctunguis catalinae* (Chamberlin), -Chamberlin, 1923, p. 396.

Type-locality: California: Catalina Island, Claremont.

Range: Known only from the type-localities.

***Nyctunguis dampfi* (Verhoeff)**

*Schendylunguis dampfi* Verhoeff, 1926, p. 103.

*Nyctunguis dampfi* (Verhoeff), -Attens, 1929, p. 88.

Type-locality: Mexico: Desierto de los Leones.

Range: Known only from the type-locality.

Notes: In describing *Simoporus koestneri*, *q.v.*, Professor Chamberlin alerted the reader to the similarity between his new spe-



cies and *dampf*i as described by Verhoeff (Chamberlin, 1940b, p. 65). The apparent similarity in many characters is indeed impressive, but its interpretation must wait until we know much more than we do now about the whole ensemble of microschendyline of which these species are members.

Through the kindness of Dr. Wilhelm Engelhardt of the Zoologische Sammlung des Bayerischen Staates at Munich I have been privileged to examine Verhoeff's original type specimens. They differ most notably (and, under the present system, generically) from *koestneri* and its congeners in their possession of two distinct pores on each coxopleuron. In *koestneri* there is reportedly just one. It is also important to report that Verhoeff's figure of the first maxillae is in error, for careful study reveals that the first maxillae of the *dampf*i holotype have distinct, though concealed, telopodite lappets as well as frail, small coxosternal lappets. Attems and others, on Verhoeff's evidence, have assumed them to be absent.

**Nyctunguis danzantinus** Chamberlin

*Nyctunguis danzantinus* Chamberlin, 1923, p. 395.

Type-locality: Mexico, Gulf of California, Danzante Island.

Range: Known only from the type-locality.

**Nyctunguis glendorus** Chamberlin

*Nyctunguis glendorus* Chamberlin, 1946b, p. 69.

Type-locality: California: Glendora, Los Angeles National Forest.

Range: Known only from the type-locality.

**Nyctunguis heathii** (Chamberlin)

*Pectiniunguis heathii* Chamberlin, 1909, p. 176.

*Nyctunguis heathii* (Chamberlin), -Chamberlin, 1914, p. 201.

Type-locality: California: Monterey Co., near Cypress Point.

Range: Known only from type-locality.

**Nyctunguis libercolens** Chamberlin

*Nyctunguis libercolens* Chamberlin, 1923, p. 395.

Type-locality: California: Stanford and environs.

Range: Known only from the type-locality.

**Nyctunguis mirus** Chamberlin

*Nyctunguis mirus* Chamberlin, 1923, p. 393.

Type-locality: Mexico: Lower California, Ensenada de Todos Santos.

Range: Known only from the type-locality.

**Nyctunguis molinor** Chamberlin

*Nyctunguis molinor* Chamberlin, 1925, p. 58.

Type-locality: Utah: Mill Creek Canyon.

Range: Known only from the type-locality.

**Nyctunguis montereus** (Chamberlin)

*Pectiniunguis montereus* Chamberlin, 1904, p. 653.

*Nyctunguis montereus* (Chamberlin), -Chamberlin, 1914, p. 201.

Type-locality: California: Pacific Grove, Bay of Monterey.

Range: California.

**Nyctunguis pholeter** Crabill

*Nyctunguis pholeter* Crabill, 1958, p. 154.

Type-locality: Tennessee: DeKalb Co., Cripps' Mill, Cripps' Mill Cave.

Range: Known only from the type-locality.

**Nyctunguis vallis** Chamberlin

*Nyctunguis vallis* Chamberlin, 1941, p. 786.

Type-locality: California: Carmel Valley, Hastings Reservation.

**SIMOPORUS** Chamberlin

?*Holitys* Cook, 1899, p. 304.

*Simoporus* Chamberlin, 1940a, p. 109.

Type-species: *Simoporus texanus* Chamberlin, 1940a. (Original designation and monotypic.)

Range: Northeastern Mexico, Texas, Arkansas. Should probably be expected throughout the Gulf States.

Notes: See notes under *Holitys* and *Nyctunguis dampfi*.

**Simoporus arcanus** Crabill

*Simoporus arcanus* Crabill, new species.

Type-locality: Arkansas: Washington Co., 4 miles west of Farmington.

Range: Known only from the type-locality.

**Simoporus koestneri** Chamberlin

*Simoporus koestneri* Chamberlin, 1940b, p. 65.

Type-locality: Mexico: Nuevo Leon, Cerro Potosi.

Range: Known only from type-locality.

Notes: See discussion under *Nyctunguis dampfi*.

**Simoporus texanus** Chamberlin

*Simoporus texanus* Chamberlin, 1940a, p. 109.

Type-locality: Texas: Bandera Co., 2 miles north of Medina.

Range: Known only from the type-locality.

## REFERENCES

- ATTEMS, C. GRAF. 1929. Das Tierreich, Lief. 52: 1-388.
- BAILEY, J. W. 1928. Bull. New York State Museum No. 276: 5-50.
- BERGSÖE, J., and MEINERT, FR. 1866. Naturh. Tidsskr. (3)4: 81-108.
- BOLLMAN, C. H. 1889. Proc. U. S. Nat. Mus. 12: 211-212.
- BROELEMANN, H. W. 1911. Bull. Soc. Ent. France 80(8): 191-193.
- BROELEMANN, H. W., and RIBAUT, H. 1912. Nouv. Arch. Mus. Hist. Nat. Paris (5)4: 53-183.
- CHAMBERLIN, R. V. 1904. Proc. Acad. Nat. Sci. Phila. 56(3): 651-657.
1909. Ann. Ent. Soc. Amer. 2: 175-195.
- 1912a. Pomona Journ. Ent. 4: 651-672.
- 1912b. Bull. Mus. Comp. Zool. Harvard 54(13): 407-436.
1914. Bull. Mus. Comp. Zool. Harvard 58(3): 151-221.
1920. Proc. Biol. Soc. Wash. 33: 41-44.
1922. Psyche 29(1): 9-10.
1923. Proc. Cal. Acad. Sci. (4)12(18): 389-407.
1925. Pan. Pac. Ent. 2: 55-63.
- 1940a. Ent. News 51: 107-110, 125-158.
- 1940b. Proc. Biol. Soc. Wash. 53: 65-66.
1941. Ann. Ent. Soc. Amer. 34(4): 773-790.
1942. Ent. News 53: 184-188.
1943. Univ. Utah Biol. Ser. 7(3): 1-55.
- 1946a. Ann. Ent. Soc. Amer. 39(2): 177-189.
- 1946b. Pan. Pac. Ent. 22(2): 64-70.
- 1947a. Pan. Pac. Ent. 23(1): 37-39.
- 1947b. Ent. News 58(6): 146-149.
- 1947c. Ent. News 58(10): 260.
- COOK, O. F. 1896.<sup>8</sup> Proc. U. S. Nat. Mus. 18: 63-75.

<sup>8</sup> Since many new forms and categories are presented in this publication, it is important to note here that although it is imprinted "1895," and although all authors to date have cited it under that year, National Mu-

1899. Proc. Ent. Soc. Wash. 4: 303-312.  
1904. Harriman Alaska Expedition 8: 47-82.  
COOK, O. F., and COLLINS, G. N. 1891. Proc. U. S. Nat. Mus. 13: 383-396.  
CRABILL, R. E., JR. 1953. Journ. N. Y. Ent. Soc. 61: pp. 93-98.  
1958. Ent. News 69(6): 153-160.  
1959. Journ. Wash. Acad. Sci. 49(9): 324-330.  
HARGER, P. 1872. Amer. Journ. Sci. Arts (3)4: 117-121.  
KOCH, C. L. 1835-44. Herrich-Schäffer, Deutschlands Insecten, Hfte. 136, 137, 142, 162, 190.  
1847. Krit. Revis. Insektenfauna Deutschlands. Herrich-Panzer, pp. 1-272.  
1863. Die Myriapoden 2: 1-112.  
MEINERT, FR. 1870. Naturh. Tidsskr. (3)7: 1-128.  
1886. Proc. Amer. Phil. Soc. 23: 161-233.  
PALMER, E. J., and STEYERMARK, J. A. 1935. Ann. Missouri Bot. Gardens 22: 375-758.  
VERHOEFF, K. W. 1926. Zool. Anz. 69(3/4): 97-105.
- 

## Some Insect Visitors of Mat *Euphorbia* in South-eastern Arizona <sup>1</sup> (Hymenoptera, Diptera)

By KARL V. KROMBEIN, Entomology Research Division,  
Agricultural Research Service, United States Department of Agriculture, Washington, D. C.

Hymenopterists collecting in the southwestern United States have known for many years of the attractiveness of the tiny flowers of *Euphorbia albomarginata* Torrey and Gray to certain small wasps and bees. The plant has a prostrate growth habit and occurs in scattered mats up to about 45 cm. in diameter. The mats are most common along roadsides where the plants receive the extra moisture from runoff. Flowers are produced

---

seum records show that this publication was actually first issued to the public on April 23, 1896.

<sup>1</sup> This contribution was made possible by a grant from the American Philosophical Society for a study of the solitary wasps and bees nesting in borings in wooden traps, and was incidental to that project; the results of the trap nest investigations will appear in a separate contribution.

over a long period of time, which makes the plant very attractive to smaller aculeates during periods when few other desert plants are in bloom.

To date no list of the particular groups of wasps and bees attracted to these flowers and their relative abundance has been published. I take this opportunity to publish some data obtained during my residence at the Southwestern Research Station of the American Museum of Natural History, July 17 to 31, 1959.<sup>2</sup> Included in an appendix is a list of the other Hymenoptera and certain Diptera obtained on the plants also. Concurrent observations were being made on several ground-nesting wasps, so I devoted only several hours on July 23, 26, 27, and 28, and most of July 24 to collecting on the *Euphorbia*. Collections were made along the desert roadside from 3 to 8 miles east of Portal, Ariz., at about 4,000 ft. elevation.

Identifications in the following list are by myself except as acknowledged.

#### Family Chrysididae

*Hedychridium* sp. 3 ♂♂.

#### Family Tiphidae

*Quemaya perpunctata* (Ckll.). 1 ♂; taken at 2 p.m. in bright sun; this is one of the few diurnal species of Brachycistidinae.

#### Family Pompilidae

*Ageniella* (*Ageniella*) *partita* Bks. 1 ♂.

*Anoplius* (*Arachnophroctonus*) *xerophilus* Evans (det. H. E. Evans). 1 ♂.

#### Family Sphecidae

*Astata nevadica* Cr. 1 ♀.

*Plenoculus cockerellii* Fox (det. F. X. Williams). 3 ♀♀, 1 ♂.

*Solierella clypeata* Wms. (det. F. X. Williams). 2 ♀♀.

*Solierella vierecki* (Roh.). 5 ♀♀, 1 ♂.

*Nitelopterus californicus* (Ashm.). 3 ♂♂♂.

*Tachysphex coquilletti* Roh. 1 ♀, 3 ♂♂♂.

<sup>2</sup>I am indebted to Director Mont Cazier for making available the facilities of the Station in support of these several projects.

*Tachysphex propinquus* Vier. 1 ♂.

*Tachysphex* sp. #1. 8 ♂♂; this and the following are small species, male with black abdomen.

*Tachysphex* sp. #2. 2 ♀♀, 1 ♂.

*Tachysphex* sp. #3. 2 ♀♀, 3 ♂♂; this and the following two are small species, females with abdomen all red, males with abdomen red and black.

*Tachysphex* sp. #4. 28 ♀♀, 23 ♂♂.

*Tachysphex* sp. #5. 17 ♀♀, 16 ♂♂.

*Xylocelia* sp. 2 ♀♀, 2 ♂♂. Apparently females of this species prefer to start their burrows in a vertical surface when one is available; on July 28 I collected 5 additional females that were attracted to the vertical walls of an excavation I had made to uncover a nest of *Eucerceris triciliata* Scullen.

*Nysson* (*Epinysson*) sp. 1 ♀.

*Foxia navajo* Pate. 1 ♀.

*Hapalomellinus* sp. 1 ♀.

*Moniaecera* (*Moniaecera*) *evansi* Pate. 1 ♀, 4 ♂♂.

*Oxybelus abdominale* Baker. 1 ♀.

#### Family Andrenidae

*Perdita* (*Perditella*) *minima* Ckll. (det. P. H. Timberlake). 5 ♀♀, 6 ♂♂; some of the females were gathering pollen.

*Perdita* (*Hexaperdita*) *callicerata* Ckll. (det. P. H. Timberlake). 1 ♂.

*Pseudopanurgus* sp. (det. P. H. Timberlake). 1 ♂.

*Calliopsis* (*Perissander*) sp. (det. P. H. Timberlake). 1 ♀.

*Calliopsis* (*Perissander*) *anomoptera* Mich. 15 ♀♀, 35 ♂♂.

Only males were taken on July 23 and 24; most of them were newly emerged, but a few showed denuded areas on the scutum indicating that they had been on the wing for several days. Freshly emerged females were present on the flowers on the 26th. Only two of these females bore pollen masses on the hind tibiae; these masses were identified by Paul S. Martin as being composed entirely of *Euphorbia* pollen, so undoubtedly the *anomoptera* females were visiting the flowers for both pollen and nectar. One male attempted to mate by flying down and alighting on a female on the *Euphorbia*, but aside from this there was no evidence of mating activity. I looked for the bur-

rows in the immediate area without finding the nesting site. I did not collect all the females that were present. P. D. Hurd collected 31 ♀♀ and 22 ♂♂ on *Euphorbia albomarginata* in this same area from August 9 to 15, 1958. A. F. Shinn reports (*in litt.*) that this species has been taken elsewhere in Arizona from July 7 to September 15, so apparently it is double-brooded.

Family Halictidae (all det. P. H. Timberlake)

*Chloralictus clematisellus* (Ckll.). 3 ♀♀, 1 ♂; the females were gathering pollen.

*Chloralictus* sp. 15 ♀♀, 1 ♂; several of the females were gathering pollen.

*Dialictus* sp. 1 ♀, 1 ♂; the female was collecting pollen.

*Sphcodes sophiae* Ckll. 1 ♀.

APPENDIX

The following parasitic Hymenoptera were collected on these flowers.

BRACONIDAE (det. C. F. W. Muesebeck): 1 ♀ *Apanteles scutellaris* Mues.; 1 ♀, 1 ♂ *Chelonus phthorimacae* Gah.

PTEROMALIDAE (det. B. D. Burks): 1 ♀ *Catolaccus aencoviridis* (Grlt.).

CHALCIDIDAE (det. B. D. Burks): 1 ♀, 1 ♂ *Hockeria* sp.; 2 ♀♀ *Euchalcidia* sp. #1; 2 ♀♀ *Euchalcidia* sp. #2.

The following Diptera also were collected on flowers. Miltongrammini were very abundant and no attempt was made to collect all specimens seen.

BOMBYLIIDAE (det. W. W. Wirth): 1 *Astrophanes adonis* O. S.; 1 *Villa lepidota* (O. S.); 1 *Villa* sp. #1; 1 *Villa* sp. #2.

CHLOROPIDAE (det. C. W. Sabrosky): 1 *Siphonella projecta* Mall.

TACHINIDAE (det. C. W. Sabrosky): 1 *Hyalomya aldrichii* Tns.; 5 *Microchaetina valida* Tns.

SARCOPHAGIDAE (all Miltongrammini, det. W. L. Downes, Jr.): 2 ♀♀ *Opsidiopsis oblata* Tns.; 1 ♀ *Senotainia rufiventris* (Coq.) (?); 1 ♂ *S. nana* Coq. (?); 2 ♀♀, 3 ♂♂ *S.* sp. near *vigilans* Allen; 11 ♀♀, 10 ♂♂ *Gymnoprosope* sp. near *polita* Tns.; 1 ♀, 1 ♂ *Eumacronychia* sp.

# Entomologist's Market Place

## ADVERTISEMENTS AND EXCHANGES

Advertisements of goods or services for sale are accepted at \$1.00 per line, payable in advance to the editor.

Notices of wants and exchanges not exceeding three lines are free to subscribers.

All insertions are continued from month to month, the new ones are added at the end of the column, and, when necessary, the older ones at the top are discontinued.

---

**Butterflies.** Wish to exchange specimens for Japanese species. Please write to Ichiro Nakamura (Boy, age 16), 26 Aza-Nichiyama Obayashi Takarazuka-shi, Hyogo-Ken, Japan.

**Phasmidae** of nearctic area desired alive. Purchase or trade, drawing on large stock of major orders, worldwide. Domminck J. Pirone, Dept. Entomology, Cornell University, Ithaca, N. Y.

**Nitidulidae and Rhizophagidae** wanted in exchange for European beetles of all families. O. Marek, Zámberk 797, Czechoslovakia.

**Wanted and Needed.** We are compiling a history of entomology, and particularly, at present, of the amateur insect clubs that flourished 50 to 75 years ago. Will you who have knowledge of such early clubs or societies advise me, giving facts on the time of existence, members, etc., which you may have. J. J. Davis, Dept. of Entomology, Purdue University, Lafayette, Indiana.

**Cockroaches (Blattoidea)** of Japan, Okinawa, Formosa (Taiwan), and the Philippines are being studied in cooperation with Dr. K. Princis. Loans of specimens from that area are desired. A. B. Gurney, U. S. National Museum, Washington 25, D. C.

**Orthoptera. Gryllinae** (except domestic sp.) and **Pyrgomorphinae** of the world wanted in any quantity for work in morphology, taxonomy, cytology, and experimental biology; dry, or in fluid, or living. Write D. K. Kevan and R. S. Bigelow, Dept. of Entomology, McGill University, Macdonald College, Quebec, Canada.

**Beetles** of the world wanted, all species in exchange for American beetles, moths and butterflies. James K. Lawton (age 18), 7118 Grand Parkway, Wauwatosa 13, Wisconsin.

**Used genuine Schmidt boxes**, excellent condition, at less than half price. H. W. Allen, Box 150, Moorestown, N. J.



# Important Mosquito Works

**MOSQUITO ATLAS. Part I. The Nearctic Anopheles, important malarial vectors of the Americas, and *Aedes aegypti* and *Culex quinquefasciata***

**MOSQUITO ATLAS. Part II. The more important malaria vectors of the Old World: Europe, Asia, Africa and South Pacific region**

By Edward S. Ross and H. Radclyffe Roberts

Price, 60 cents each (U. S. Currency) with order, postpaid within the United States; 65 cents, foreign.

---

## KEYS TO THE ANOPHELINE MOSQUITOES OF THE WORLD

With notes on their Identification, Distribution, Biology and Relation to Malaria. By Paul F. Russell, Lloyd E. Rozeboom and Alan Stone

Mailed on receipt of price, \$2.00 U. S. Currency. Foreign Delivery \$2.10.

---

For sale by the American Entomological Society, 1900 Race Street, Philadelphia 3, Pa., U. S. A.

---

## Just Published

### New Classified Price Lists

Available separates from the TRANSACTIONS OF THE AMERICAN ENTOMOLOGICAL SOCIETY and ENTOMOLOGICAL NEWS, and all titles of the Society's MEMOIRS have been catalogued by author in twelve special price lists in the following categories:

Coleoptera  
Diptera  
Hemiptera  
Hymenoptera  
Lepidoptera  
Memoirs

Neuroptera and Smaller Orders  
Odonata  
Orthoptera-Dermoptera  
Arachnida and Other Classes  
Bibliography-Biography  
General

Lists will be mailed free upon request. Please state specifically which list or lists you require.

**The American Entomological Society**  
1900 RACE STREET  
PHILADELPHIA 3, PENNSYLVANIA

## Just Published

### A MONOGRAPH OF THE ORTHOPTERA OF NORTH AMERICA (NORTH OF MEXICO).

Volume I. Acridoidea in part, covering the  
Tetrigidae, Eumastacidae, Tanaoceridae, and Ro-  
maleinae of the Acrididae.

By James A. G. Rehn and Harold J. Grant, Jr.

282 pages of text, with 401 text-figures (including distributional maps)  
and 8 half-tone plates.

This monograph brings into concise form our knowledge of the genera and species of the groups covered—as present in the United States and Canada. In this work the authors have had access to all the important series contained in institutions in North America. This monograph summarizes the detailed conclusions set forth in various collateral publications, as well as other pertinent matter of broader coverage. Almost all existing type material was examined in the course of the work, and, in addition to the published literature, field observations, covering over fifty years of study over a large part of the area treated, were drawn upon in forming the conclusions. Keys to all of the taxonomic entities discussed are presented, and nearly all of the illustrations used are new.

---

Monograph No. 12 of the  
Academy of Natural Sciences of  
Philadelphia

Price \$10.00 postpaid  
(add 10% to cover handling of foreign orders)

---

Publications Department  
ACADEMY OF NATURAL SCIENCES OF PHILADELPHIA  
19th and The Parkway  
Philadelphia 3, Pa., U.S.A.

Ins.

# ENTOMOLOGICAL NEWS

APRIL 1961

Vol. LXXII

No. 4

---

## CONTENTS

Gertsch—Herbert Ferlando Schwarz, 1883–1960 .....	85
Cooper—European pselaphid beetle in New York .....	90
Scott—Collembola of New Mexico, IV .....	93
Chamberlin—Geophilid chilopods of Utah .....	96
Book Notices .....	100
Hull—The genus <i>Psilocurtus</i> Loew .....	101
Spilman—Immature stages of Ptilodactylidae .....	105
Alexander—Type locality of <i>Gomphocerus clavatus</i> .....	107
Book Notice .....	111

---

PUBLISHED MONTHLY, EXCEPT AUGUST AND SEPTEMBER, BY  
 THE AMERICAN ENTOMOLOGICAL SOCIETY  
 PRINCE AND LEMON STS., LANCASTER, PA.  
 AND  
 1900 RACE STREET, PHILADELPHIA 3, PA.

---

Subscription, per yearly volume of ten numbers: \$5.00 domestic; \$5.30 foreign; \$5.15 Canada.  
 Second-class postage paid at Lancaster, Pa.

DEPT. ENT.  
 ENTOM. SOC. AM.

# ENTOMOLOGICAL NEWS

---

**ENTOMOLOGICAL NEWS** is published monthly, excepting August and September, by The American Entomological Society at Prince and Lemon Sts., Lancaster, Pa., and the Academy of Natural Sciences, 1900 Race Street, Philadelphia 3, Pa., U. S. A.

**PHILIP P. CALVERT**, Editor Emeritus. **R. G. SCHMIEDER**, Editor. Editorial Staff: **H. J. GRANT, JR.**, **E. J. F. MARX**, **M. E. PHILLIPS**, and **J. A. G. REHN**.

**SUBSCRIPTIONS:** Communications and remittances to be addressed to **Entomological News, 1900 Race Street, Philadelphia 3, Pa.**

Prices per yearly volume of 10 numbers.

**Private subscriptions**, for personal use: in the United States, \$5.00; Canada, \$5.15; other countries, \$5.30.

**Institutional subscriptions**, for libraries, laboratories, etc.: in the United States, \$6.00; Canada, \$6.15; other countries, \$6.30.

**ADVERTISEMENTS:** Rate schedules available from the editor.

**MANUSCRIPTS** and all communications concerning same should be addressed to **R. G. Schmieder, Zoological Laboratory, University of Pennsylvania, Philadelphia 4, Pa.**

The receipt of all papers will be acknowledged and, if accepted, they will be published as soon as possible. Articles longer than eight printed pages may be published in two or more installments, unless the author is willing to pay the cost of a sufficient number of additional pages in any one issue to enable such an article to appear without division.

**ILLUSTRATIONS:** Authors will be charged as follows: For text-figures, the cost of engraving; for insert plates (on glossy stock), the cost of engraving plus printing. Size limit, when printed, 4 × 6 inches. All blocks will be sent to authors after printing.

**TABLES:** The cost of setting tables will be charged to authors.

**SEPARATA:** Members of the American Entomological Society may elect to receive, gratis, 25 offprints of their contributions. These will be "run-off-form," without removal of extraneous matter.

Those members desiring more than 25 separates, and all non-members, will receive no gratis copies. They must obtain all their separates (as reprints, with extraneous matter removed) from the printer at the prices quoted below. Authors must place their order for such separates with the editor at the time of submitting manuscripts, or when returning proof.

Copies	1-4 pp.	5-8 pp.	9-12 pp.	Covers
50	\$4.35	\$6.96	\$10.88	\$4.74
100	5.21	8.26	13.05	6.48
Add'l 100	1.74	2.60	4.33	3.48

Plates printed one side: First 50, \$3.47; Additional 100's, \$2.61.

Transportation charges will be extra.





HERBERT FERLANDO SCHWARZ

# ENTOMOLOGICAL NEWS

---

---

VOL. LXXII

APRIL, 1961

No. 4

---

---

## Herbert Ferlando Schwarz 1883-1960

After a full life of service and devotion to family, friends and country, Herbert Schwarz died on October 2, 1960. He was one of those rare individuals whose high code of honor and genuine sincerity charmed all who met him. He left behind friends in numbers in all parts of the world who will long remember him for his kindness, generosity and graciousness. A man of exceeding modesty, he took pleasure in praising the deeds and works of others but never mentioned his own. A man of great patriotism and love of country, he served in the Field Artillery during the First World War. A dedicated scholar all his life, he applied his broad knowledge to several fields with outstanding success. He stood high in the esteem of scientific colleagues throughout the world and left as his monument papers on bees that will long remain definitive works on the group. To his closest friends Herbert Schwarz personified all that was fine and noble in man.

Herbert Schwarz was born on Fire Island, near Long Island, New York, on September 7, 1883, the son of Frederick A. O. Schwarz and Caroline Clausen Schwarz. His preparatory schooling was acquired at the Phillips Exeter Academy, from which he graduated in 1900. After four years of work at Harvard University, he received the Bachelor of Arts degree in 1904. His liberal education emphasized literature, writing and languages, and in 1905, after a year of graduate study he was awarded the Master of Arts degree in philosophy. Continuation of his schooling at Columbia University brought him another Master of Arts degree in Elizabethan literature in

1907. Among his later honors was election to Sigma Xi. As an undergraduate he developed a keen interest in natural history and anthropology, especially Indian lore, which was responsible for taking him into the Southwest in 1904 and 1905 for study of the aboriginal cultures of that area. Fascinated by the lives and myths of the Navajos and the Pueblo tribes, he brought together a large body of notes on these peoples. One of his first published papers was concerned with the "Spider Myths of the American Indians" and brought to light many of the charming details of this Indian mythology.

Herbert Schwarz always identified himself with the metropolitan area and spoke in the manner of the cultured New Yorker. His father had come to this country from Herford in Germany and had established the F. A. O. Schwarz toy company on Fifth Avenue, which in its specialty has become one of the landmarks of the city. Herbert was associated with the business for over fifty-five years, as an officer of the corporation in its early days and as a director during the last twenty-seven years of his life. His proficiency in modern languages was undoubtedly aided by numerous travels to all parts of the world. He spoke and read German fluently and had an excellent knowledge of Spanish, French and other Romance languages which he continued to study most of his life.

Schwarz in 1910 married Dorothy Constable, who was his frequent companion on subsequent trips and maintained a close interest in all his activities. Their four daughters are: Mrs. Barbara French, Mrs. Eleanor Stock, Mrs. Dorothy Hines and Miss Marjorie Schwarz.

During the period from 1909 to 1919 Herbert Schwarz acted as head of the editorial department and member of the board of G. P. Putnam's Sons in New York City. With a command of word and phrase reserved only to the gifted, it was inevitable that Schwarz would shine in the editorial and publishing field. He wrote fluently with a bold, handsome script and was a voracious reader of good books. A grievous fault, or so he told me, was his addiction to polysyllabic words and a ready acceptance of repetition with eddying currents of thought to bring out finer



flavors and more exact meanings in writings. His leanings toward anthropology and natural history qualified him for editorial participation in the Putnam Field Book series.

To Schwarz, as editorial and lay adviser, came a book which was to have strong influence in shaping his future life. This was the "Field Book of Insects" by Dr. Frank E. Lutz, then curator of insects of the American Museum of Natural History. This work was published in 1918 and still remains, after forty years, the outstanding field guide on insects for the amateur and general student. Lutz and the gentle, reserved Schwarz were about the same age and they quickly became close personal friends. They were opposites in many ways, with Lutz a man of penetrating mind who loved nothing more than to shock friend and foe with piercing barbs. Lutz kindled in Schwarz his first interests in insects and, because of his own liking for the biology and physiology of the bees, directed Schwarz's attention to the study of these captivating social insects. On many occasions Herbert Schwarz expressed his great admiration for Frank E. Lutz and regarded him as his teacher and mentor.

Herbert Schwarz's career at the American Museum of Natural History began in a modest way in 1919 when he spent three months in Colorado as a volunteer assistant with Dr. Lutz on a field expedition from the Department of Entomology. It was on this or a similar trip that he first met T. D. A. Cockerell who further encouraged his interest in bees and with whom he shared a close friendship and engaged in voluminous correspondence until Cockerell's death. In 1921, Schwarz was appointed as Research Associate of the Department of Entomology and he retained this post until his death, on a nearly full time basis. His interest in the American Museum and its manifold activities was very great and he participated in many ways. Thus, from 1921 to 1925 he was editor of *Natural History* magazine, and, following the death of Dr. Lutz in 1943, Schwarz was appointed acting chairman of the Entomology Department of the Museum, and he gave unreservedly of his time during the war period.

Once he had succumbed to the lure of insects, Herbert

Schwarz swiftly became a full-fledged entomologist and participated in many Museum field trips to far places. On most of these he was accompanied by one or both of his closest personal friends, Frank E. Lutz and Irving Huntington, but other trips were taken alone. Some of the areas visited were: Colorado, 1919; southern Florida in 1923; the Brownsville region of Texas in 1925; Barro Colorado Island, Canal Zone, in 1930 and 1933; the Cauca Valley of Colombia, in 1935; central Mexico and Yucatan in 1946; and southern Mexico in 1947. In addition to these collecting and field study expeditions Schwarz visited museums and scientific institutions all over the world, often with his wife and members of the family.

During his life Schwarz was active in many organizations to which he gave generously of time and money. As a Harvard graduate with fondest memories of early school years, he maintained close ties with his university and its Museum of Comparative Zoology and served on many committees. He often entertained friends and visitors at the Harvard Club on West Forty-fourth Street in New York, where his geniality as host will always remain a bright spot in the memories of his guests. As a Corresponding Member of the American Entomological Society, Schwarz was personally well-known to the older group of its membership. To Mr. J. A. G. Rehn, he was a good friend and "one of nature's noblemen, beloved by all who knew him for his many kindnesses, his courtesy—things increasingly rare in this matter-of-fact world."

Local organizations claimed a large share of Schwarz's interest. In 1919 he joined the New York Entomological Society and maintained a constant interest until his death. Here he fraternized with such now departed or inactive entomological stalwarts as William T. Davis, John D. Sherman, Ernest Bell, Andrew Mutchler, Charles Leng, and Frank Watson. He served on many committees, on the Board, and as President of the New York Entomological Society in 1935. He was also active in the National Audubon Society and the New York Academy of Sciences. Of the latter he was a Fellow and Council member for many years and Editor of Publications from

1925 to 1936. Another of his great interests was the Explorers' Club which he joined in 1921 and to which he gave sterling service as a Director and on various committees for many years. He was also for many years a member of Squadron A, a local cavalry group, which had its headquarters in the Old Armory.

Many of Schwarz's early papers were published in *Natural History* magazine during his tenure as editor. The broad scope of his writing is reflected in such titles as "Floral Designs in Textiles," "Eclipses, as Interpreted by the American Aborigines," "Swinging a Net in Southern Florida" and what may well have been his first published writing, "Tobacco as a Cure for Ailments." Thereafter, most of his publications, totalling at least sixty, were scientific contributions dealing rather exclusively with the bees of two groups. Much of what is known on the megachilid bees of the subfamily Anthidiinae we owe to Schwarz whose series of basic papers is still the standard reference for the group. The stingless honeybees of the family Meliponidae (or Apidae) became Schwarz's special province and made him known to entomologists throughout the world. His greatest work is a voluminous tome exceeding five hundred printed pages, profusely illustrated, and entitled "Stingless Bees (Meliponidae) of the Western Hemisphere," which was published as a *Bulletin of the American Museum of Natural History*. Almost one third of these pages are devoted to the biology and natural history of stingless bees of the entire world and the remainder assigned to the systematics of the principal genera of the New World. This work will long remain a personal monument to the untiring devotion of a fine man. In its size and scope we see so much of what we admired in the man; it is the fruit of a keen, inquiring mind delineated in a boundless wealth of expression, an enduring work on a group of insects which he grew to love.

WILLIS J. GERTSCH

## Occurrence of the European Pselaphid Beetle *Trichonyx sulcicollis* (Reichenbach) in New York State

By KENNETH W. COOPER, Hanover, N. H.

Nearly 30 years ago (June 13, 1931), at Kissena Lake Park, Flushing, L. I., I collected a large female pselaphid beetle (*ca.* 2.5 mm. long) from under bark and in company with the ant *Lasius umbratus* (Nyl.). In 1947 the specimen came into Prof. Orlando Park's possession when he purchased the Pselaphidae in the collection of my boyhood friend and teacher, the late Charles A. Schaeffer of the Brooklyn Museum. Park identified the beetle as *Trichonyx sulcicollis* (Reichenbach), a fairly uncommon euplectine pselaphid found throughout much of Europe.

"Since no species of pselaphid has been known to inhabit both Europe and the United States," Park (1953a) says, "the reader may well imagine with what care this New York insect was identified, and the determination checked and rechecked over the past several years." Though Flushing, locale of the well-known and extensive nineteenth century Prince (= "Linnaean Botanic Gardens," founded *ca.* 1737) and Bloodgood (founded *ca.* 1797) nurseries, the early histories of which have been commented upon by Mandeville (1860), had in fact been the site of discovery of two other introduced beetles (*Asaphidion flavipes* L., and *Bitoma crenata* Fabr., *v.* Cooper 1930). Park was extremely cautious in concluding that the specimen of *Trichonyx sulcicollis* (Reich.) before him represented a genuine introduction. Indeed his comments impelled me, during brief visits to Flushing in late springtime (1956-60), to search in the region of the original capture even though it has long been destroyed as a natural area. *Bitoma crenata* Fabr. is still frequent in the area, especially under the bark of cherry, but neither *Asaphidion* nor *Trichonyx* were found there again. Unexpectedly, however, *Trichonyx sulcicollis* (Reich.) has recently been found at Rochester, N. Y., and there can no longer be question that this pselaphid is present in our fauna and should be included in our catalogs and keys.

The second specimen, also a female, was found in a Berlese funnel sample made by Prof. William B. Muchmore, expert on isopods and pseudoscorpions, at Rochester, N. Y. (sample 124; May 25, 1957; old mouse nest occupied by bumblebees, from under old railroad tie, River Boulevard near Mt. Hope Cemetery), within the city limits. The pselaphid, awakening dormant memory the moment I viewed the sample, ran directly to *Trichonyx* in Park's (1953) key to the genera of pselaphids of the U. S., and checked well with *Trichonyx sulcicollis* (Reichenbach) in the only European keys and descriptions available to me (namely Seidlitz, 1891; Ganglbauer, 1895). Park has confirmed my identification (letter of May 17, 1960), and the specimen remains in his collection along with that originally caught in Flushing.

As in the first case, The Rochester specimen of *Trichonyx sulcicollis* (Reich.) was also taken in association with ants, and most remarkably with *Ponera coarctata pennsylvanica* Buckley (det. by Dr. M. R. Smith, U.S.N.M.). Correspondingly the Rochester locality at which the pselaphid was taken is not far from the site of an old Rochester nursery which, until the first World War, imported stock from Europe, and the area now harbors enduring populations of the European isopods *Hyloniscus riparius* (Koch) and *Platyarthrus hoffmanseggi* Brandt (Muchmore, 1957), as well as the European geophilomorphous centipede *Chaetechelyne vesuviana* (Newport) (Crabill, 1955), and a blind hypogaean colydiid beetle that is also most probably an importation from Europe (unpublished).

The two records of *Trichonyx sulcicollis* (Reich.) from New York State, no less the details of each capture, indicate that this beetle is established in the United States, and probably has been so established for well over 30 years. Donisthorpe (1927) and Ganglbauer (1895) give *Lasius brunneus* (Latr.) and *Ponera coarctata* (Latr.) [but as *P. contracta* (Latr.)] as ant associates in Europe, and it is a striking fact that the two New York *Trichonyx* were found in the company of the related *Lasius umbratus* (Nyl.), also occurring in Europe, and the closely similar *Ponera coarctata pennsylvanica* Buckley. Association here

with appropriate ants, one of which is regarded as endemic, bespeaks successful immigration. It is, of course, most likely that the Rochester and Flushing areas were independently colonized, and it would not be surprising were *Trichonyx* to remain unfound or rare in intervening localities.

It is pleasant to thank Dr. Muchmore for his kindness in permitting me to sort through his extensive Berlese funnel samples, the unmounted remainder of which are now deposited in the U. S. National Museum.

## CITATIONS

- COOPER, K. W. 1930. Bull. Bklyn. Ent. Soc. 25: 21-24.
- CRABILL, R. E. 1955. Ent. News 66: 248-249.
- DONISTHORPE, H. ST. J. K. 1927. The guests of British ants. xxiii + 244 pp., ill. Routledge and Sons, London.
- GANGLBAUER, L. 1895. Die Käfer von Mitteleuropa. 2 Bd., 1 Theil, 880 s. Wien.
- MANDEVILLE, G. H. 1860. Flushing, past and present: a historical sketch. 180 pp., ill. Publ. by Home Lecture Committee of 1857-8, Flushing.
- MUCHMORE, W. B. 1957. Jour. Washington Acad. Sci. 47: 78-83.
- PARK, O. 1953a. Nat. Hist. Miscell. Chicago Acad. Sci. No. 117 (3 pp.).
- . 1953b. Bull. Chicago Acad. Sci. 9: 299-331.
- SEIDLITZ, G. 1891. Fauna Baltica. Die Kaefer. 2 Aufl., 10 + lvi + 818 s. Königsberg.

The Collembola of New Mexico. IV.  
A New Genus of Isotominae<sup>1, 2</sup>  
(Entomobryidae)

By HAROLD GEORGE SCOTT<sup>3</sup>

Prior to the species recorded in this part, only 2 species of Isotominae were recorded from New Mexico: *Isotomurus retardatus* (by Folsom, 1937), and *Proisotoma frisoni* (by Scott, 1958). Specimens will be deposited with the Academy of Natural Sciences, Philadelphia, Pennsylvania.

GENUS *BIACANTHELLA* gen. nov.

TYPE SPECIES. *Biacanthella neomexicana* gen. et sp. nov.

DESCRIPTION. Body elongate, not subglobose; integument smooth, non-tuberculate; clothing of simple setae; bothriotricha absent; antenna 4-segmented, thick, heavy; postantennal organ elliptical, simple; eyes 8 and 8; mouthparts mandibulate; prothorax much shortened, membranous, with 1 or no setae dorsally; tenent hairs absent; unguiculus present; furcula present, short, not attaining colophore; mucro not ankylosed with dens; genital segment enlarged, anal segment reduced; anal spines 2, anus ventro-terminal.

DISCUSSION. *Biacanthella* shows both hypogastrurine and isotomine characteristics, but is placed in the subfamily Isotominae because of its reduced, membranous pronotum. It differs from other known genera of Isotominae in the following combination of characters: Anal spines 2, furcula and unguiculus present, anus ventro-terminal.

<sup>1</sup> A portion of a dissertation submitted to the Graduate Faculty of the University of New Mexico, Albuquerque, in partial fulfillment of the requirements for the Degree of Doctor of Philosophy.

<sup>2</sup> Part III appeared in Ent. News, 71(3): 57-65.

<sup>3</sup> Training Branch, Communicable Disease Center, Public Health Service, U. S. Department of Health, Education, and Welfare, Atlanta, Georgia.

***Biacanthella neomexicana*** gen. et sp. nov. Figures 1-8

TYPE LOCALITY. Holotype and 31 paratypes, Doc. Long's Picnic Area, Sandia Mts., Bernalillo Co., New Mexico; Berlese of Gambel oak litter, 7,400 ft., 29-v-1951, by C. Clayton Hoff.

DESCRIPTION. Body elongate, clearly segmented; integument smooth, appearing minutely tuberculate under high magnifications; white, speckled dorsally with blue-gray on the tergites and head; antenna light blue-gray; legs and furcula white; body sparingly clothed with moderately long curving simple setae with a few peculiar bifurcate setae scattered laterally on the thorax; setae few anteriorly, becoming more-and-more numerous posteriorly until they are profuse on Abd VI; bothriotricha absent; head prognathous; ratio of antenna to head approximately 23:26; Ant IV with terminal tubercle, subapical papilla and slender curving olfactory setae; Ant III sense organ with 2 oblique basally bent sense rods and a protective integumentary fold; postantennal organ elliptical, simple, consisting of a single tubercle; eyes 8 and 8, subequal in size; pigmented eyepatches absent during life, but some ocular pigment may become visible in specimens after mounting; mouthparts mandibulate; ratio of prothorax to mesothorax to metathorax as 7:19:16; prothorax reduced, membranous with 1 seta located in the mid-dorsum of the pronotum; mesonotum not covering prothorax dorsally; trochanteral organ absent; tibiotarsus without distal subsegment; inner edge of unguis simple, curved strongly; ratio of unguiculus to unguis as 7:16; unguiculus not toothed; tenent hairs represented by a single unknobbed seta on each foot; segments of abdomen not overlapping but with well-developed intersegmental membranes; Abd III urotergite not ventro-laterally prolonged backward; sacs of ventral tube small; furcula reaching to caudal edge of Abd I and apparently attached to Abd IV;

---

*Biacanthella neomexicana* gen. et sp. nov.

1. Lateral view, 2. dorsal view, 3. lateral view of mucro, 4. lateral view of pronotum, 5. lateral view of left anal horn, 6. lateral view of left front foot, 7. left eyes and postantennal organ, 8. bifurcate seta on right side of mesothorax in dorsal view. Figures 2 and 8 of paratype, all others of holotype. Arrow indicates anterior for all figures.



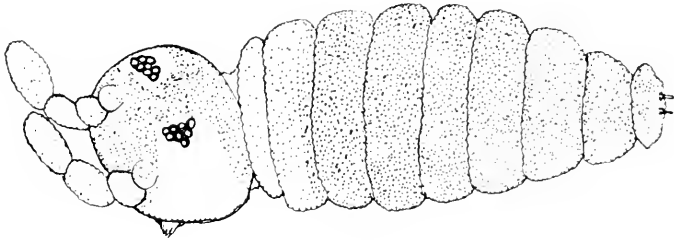
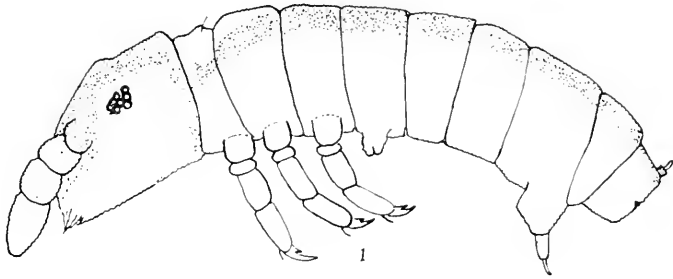

2

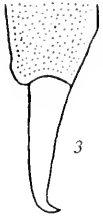

3



4

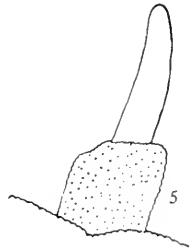

5

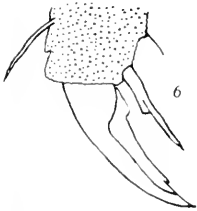

6



7



8

ratio of manubrium to dens to mucro as 9:7:2; manubrium with ventral setae; mucro unidentate; genital segment enlarged, anal segment reduced; anal appendages absent; length 1.0 mm.

## REFERENCES

- FOLSOM, J. W. 1937. Bull. U. S. Natl. Mus. 168: 71-72.  
SCHAFFER, C. 1896. Mitt. Naturh. Mus. Hamburg 13: 147-216.  
SCOTT, H. G. 1958. Ent. News 69(8): 202.  
TOMOSVARY, O. 1882. Math. Term. Kozlem. Magyar Akad. 18: 119-130.
- 

## Notes on the Geophilid Chilopods of Utah

By RALPH V. CHAMBERLIN

This list of members of the Geophilida known to me personally as occurring in Utah has been drawn up primarily to assign to more recently recognized genera some of the species that were described many years ago.

### Chilenophilidae

#### *Arctogeophilus atopus* (Chamberlin)

*Geophilus atopus* Chamberlin, 1902, Amer. Nat. 36: 476.

This species is readily distinguishable superficially from related congeners in that the claw of the anal legs is represented by a small process or cuticular point only or, sometimes, is entirely absent. A very characteristic feature is the small median sharply defined circular clypeal area which is preceded by a pair of setae and followed by another pair. The labrum conforms rather closely to that of the generotype, *A. glacialis* Attems. The pairs of legs number prevailingly 67 or 69 but may be as few as 63.

This species is at present known from northern Arizona, from various points in Utah, and from Wyoming (e.g., at Devil's Tower).

**Arctogeophilus umbraticus** (McNeill)

*Mecistocephalus umbraticus* McNeill, 1887, Proc. U. S. Nat. Mus. 10: 322.

*Geophilus xenoporus* Chamberlin, 1902, Amer. Nat. 36: 475.

*Gnathomerium americanum* Ribaut, 1912, Bull. Soc. Toulouse 43: 120, figs. 12-17.

This widespread species seems to be the most abundant geophilid in Utah where it is common under decaying leaves and in leaf mold along the canyon streams of the Wahsatch, Uintah and Oquirrh Mts., etc.

**Watophilus utus** Chamberlin

*Watophilus utus* Chamberlin, 1928, Ent. News 39: 95.

This small geophilid, distinguishable from other known species by its larger number of legs, 65 pairs, is to date recorded or known only from San Juan Co., where it has been taken at Verdure, Bluff, and between LeSal and Moab.

## Pachymerinidae

**Zygoterium rotarium** Chamberlin

*Zygoterium rotarium* Chamberlin, 1943, Proc. Biol. Soc. Washington 56: 100.

Known only from the holotype which was taken in City Creek Canyon, near Salt Lake City.

## Geophilidae

**Brachygeophilus glyptus** (Chamberlin)

*Geophilus glyptus* Chamberlin, 1902, Amer. Nat. 36: 477.

This species occurs in the canyons of the Wahsatch, Oquirrh, and Stansbury Mts. While it appears to range into Idaho, Oregon specimens earlier referred to it belong to *B. oregonus*. A readily recognized difference is that while in *glyptus* the labrum is fimbriate throughout with about 12 processes on the median piece, in *oregonus* the median piece is not fimbriate but bears 5 or 6 stout teeth. Although *glyptus* sometimes bears a small tooth at the base of the claws of the prehensors, this is

often obsolete or absent. These claws when closed extend to or a little beyond the distal end of the first antennal article. The last ventral plate is very wide with its sides strongly converging caudad. The coxal pores number about 12 on each side, these partly covered by the sternite. The anal legs are clothed with abundant very short hairs and fewer long setae. Most commonly there are 67 or 69 pairs of legs but there may be as few as 63 pairs. The body length in grown specimens is commonly about 45 mm.

**Geophilus fruitanus** Chamberlin

*Geophilus fruitanus* Chamberlin, 1928, Ent. News 39: 310, 1930, Pan-Pacific Ent. 6: 114.

This species is as yet known only from Wayne Co. where it has been taken at Fruita and in Horse Valley.

**Geophilus pedus** Chamberlin

*Geophilus pedus* Chamberlin, 1930, Pan-Pacific Ent. 6: 114.

Known only from the male holotype which was taken at St. George, Washington Co.

**Geophilus shoshoneus** Chamberlin

*Geophilus shoshoneus* Chamberlin, 1925, Pan-Pacific Ent. 2: 59.

Recorded from Cache Co., where taken in Logan Canyon and on the divide between this canyon and the Bear Lake valley.

**Geophilus vittatus** (Rafinesque)

*Mycotheres (Nemopleura) vittata* Rafinesque, 1820, Annals of Nat. 1: 8.

*Geophilus rubens* Say, 1821, Journ. Acad. Nat. Sci. Phila. 2: 113.

*Geophilus vittatus* (Rafinesque), Crabill, 1954, Proc. Ent. Soc. Washington 56: 177.

This widespread species, which is rather common in Arizona and Idaho, is recorded from Washington Co., Utah, and will probably be found elsewhere throughout the state.

## Dignathodontidae

**Damothus montis** Chamberlin

The type of this new form, a description of which is in course of publication elsewhere, was taken in Dry Canyon near Salt Lake City.

**Linotaenia chionophila** (Wood)

*Strigamia chionophila* Wood, Journ. Acad. Nat. Sci. Phila. ser. 2, 5: 50.

*Linotaenia miuropus* Chamberlin, 1902, Amer. Nat. 36: 475

*Linotaenia chionophila* Chamberlin, 1911, Canadian Ent. 43: 260, 1923, N. A. Fauna 46: 212, 1925, Pan-Pac. Ent. 2: 59, 1928, Ent. News 39, 310, 1930, Pan-Pac. Ent. vol. 6, p. 114.

This species, abundant throughout Alaska and adjacent parts, has been found in the mountains throughout Utah.

**Linotaenia fulva** (Sager)

*Strigamia fulva* Sager, 1856, Proc. Acad. Nat. Sci. Phila. 8: 109.

*Linotaenia micropus* Chamberlin (part. max.), 1902, Amer. Nat. 36: 479.

*Strigamia fulva* Sager, Crabill, 1954, Ent. News 65: 41.

Occurring in canyons of the Wasatch Mts., especially at higher levels, from Cache to Sevier Co.

## Himantariidae

**Stenophilus hesperus** (Chamberlin)

*Haplophilus hesperus* Chamberlin, 1928, Ent. News 39: 309.

Known thus far only from the holotype, a specimen 35 mm. long and possessing 71 pairs of legs, with claws of prehensors very slender. The mouthparts, which were not mentioned in the original account, conform in general to those of other known species of the genus but differ in details. The diastema in the coxosternum of the second maxillae is deeper and wider than in the other forms and the pectinae or processes of the labrum are more numerous.

## Schendylidae

**Escaryus monticolens** Chamberlin

*Escaryus monticolens* Chamberlin, 1947, Pan-Pac. Ent. 23: 37.

Known only from Mill Creek Canyon, Salt Lake Co.

**Gosendyla socarnia** Chamberlin

A newly discovered form a description of which is appearing elsewhere.

**Nyctunguis molinor** Chamberlin

*Nyctunguis molinor* Chamberlin, 1925, Pan-Pac. Ent. 2: 58.

Known only from the mouth of Mill Creek Canyon, Salt Lake Co.

**Schendyla nemorensis** (C. L. Koch)

*Geophilus nemorensis* (C. L. Koch), 1836, Crust., Myr., u. Arachnida vol. 4, fasc. 9.

*Schendyla nemorensis* Bergsøe and Meinert, 1866, Naturhist. Tidsskr. ser. 3, 4: 105.

*Schendyla nemorensis* Bergsøe and Meinert, Chamberlin, 1909, Ann. Ent. Amer. 2: 175.

Not uncommon in Salt Lake and Utah counties.

---

**Book Notices**

QUATE, L. W. Psychodidae. Guide to the Insects of Connecticut, Part VI, Diptera, Fasc. 7. State Geol. and Nat. Hist. Survey, Bull. 92. Pp. 1-54, 7 pls. Distributed by Robert C. Sale, Librarian, State Library, Hartford, Conn. Has keys to genera of N. America and to species of northeastern region.

SELANDER, R. B. Bionomics, Systematics and Phylogeny of *Lytta*, a Genus of Blister Beetles (Coleoptera, Meloidae). Illinois Biological Monographs, No. 28, Pp. 1-295. University of Illinois Press, Urbana, Ill., 1960. Price: paper, \$4.50; cloth, \$5.50.

## The Genus *Psilocurus* Loew

By FRANK MONTGOMERY HULL, University of Mississippi

This small and interesting genus is predominantly Nearctic. Recently a species has been described by Oldroyd from the near East, making a total of seven known species, one of them Mexican. The author has collected six species in recent years, two of which are new and here described.

### *Psilocurus pygmaeus*, new species

This species differs from *Psilocurus puellus* Bromley in that the under surface of the femora are black, except quite near the apex where they are a little reddish. Also the last 3 or 4 segments of the abdomen are light red in color. Length 7-8 mm.

Male. *Head*: The head is black, everywhere dusted with dense, greyish white pollen or fine micropubescence. Pile of the lower occiput white. Weak bristles start on the occiput below the middle of the head and are yellowish white in color, and become a little longer or more stout behind the vertex. Ocellarium with 1 or 2 minute hairs and wholly pollinose. Face with a few fine, short, yellowish white hairs distributed over the middle, each of them curled downward. Lower margin of the face with about 5 pairs of slender, rather tectiformed, pale yellow bristles. Palpus and proboscis shining black. Antenna black, first segment with a rather long, slender, white, bristly hair below, the second segment with comparatively long, black setae at the apex above and below. Third segment rather short oval, but pointed at the apex, widest across the middle, relatively broad and equally tapered from the middle in each direction.

*Thorax*: The thorax is shining black but rather obscured by completely appressed, short, coarse, brassy yellow pile. In addition the humerus and lateral margin of the postalar callosity are greyish to silvery white pollinose. The whole of the metanotum and all of the pleuron, except 2 abbreviated, vertical bare stripes, are densely silvery white pollinose. Scutellum black

with the same appressed yellowish pile as the mesonotum. Halteres pale yellow. Scutellum with 1 pair of black bristles, postalar callosity, supraalar region and notopleuron each with a black bristle.

*Legs:* The legs are black. The extreme apex of the front and middle femora dorsally, the ventral surface on the apical half only of these femora, the extreme base of the hind femur and the apical fifth of the hind femur ventrally reddish in color; also the extreme apex only of all the tibiae brownish yellow or orange. Legs covered with completely appressed, fine, pale yellow pile and with a few short, pale yellow bristles, which are comparatively long on the first 3 tarsal segments.

*Wings:* The wings are hyaline, except for very fine, brown villi. Venation typical.

*Abdomen:* The abdomen is slender, black on one to three basal segments, becoming reddish on the remainder of the abdomen and light orange brown on at least the last tergite and terminalia. Apex of prongs of surstylus black. Terminalia inverted. Sides of the tergites with 2 weak yellow bristles on each of the first three, 1 or 2 on the remaining tergites. Posterior triangles along the lateral margin of the tergites with thin, silvery white pollen which is easily obscured in individuals with bad preservation.

*Holotype:* Male, 20 miles west of Toyah, TEXAS, August 4, 1954, collected by F. M. Hull. Two *paratype* males with the same data.

### ***Psilocurus tibialis*, new species**

A large black species. Femora of the male black, of the female light red. Tibiae black in both sexes. Length 10 mm.

Male. *Head:* The head is black, densely greyish white pollinose except on the upper occiput and posterior part of vertex where the pollen is brownish yellow, and on the face where the pollen and micropubescence is silvery. Middle of face with a few short, silvery hairs. Bristles of occiput, face and middle bristle from the middle of ventral surface of first antennal segment light yellow. Lower face quite rounded, the whole lower



third or more with moderately long, slender, yellowish bristles. Proboscis and antenna black.

*Thorax:* The thorax is dull black with flat appressed, brassy pile laterally. The middle of the mesonotum with much shorter appressed black hairs and a few brassy hairs intermixed. Pleuron yellowish to whitish pollinose, except for a bare, black stripe above the middle coxa and a similar spot above the hind coxa. Halteres yellowish, scutellum with yellowish pile, in both sexes with 1 pair of long, stout, black bristles. Mesonotal bristles black.

*Legs:* The femora are quite stout, in the male the legs are entirely black except for the extreme apex of all the femora and the extreme base of their tibia, which are yellowish to brownish. Pile appressed, brownish to yellowish white on the femora, rather silvery on the front and middle tibia and tarsi, black on the hind tibia and tarsi. Femora in the female entirely light red, their tibia are black except narrowly at the base which is yellowish. Pile as in the male, except that on hind tibia and tarsus the pile is light brassy to brownish yellow.

*Wings:* The wings are very pale brown, much of the color due to villi.

*Abdomen:* The abdomen is robust, quite black with a slight opalescent blue color but without any metallic or steel blue reflections. First 3 tergites laterally with large, greyish white, pollinose triangles. Fourth and fifth tergites with shorter triangles, which, however, are extended much farther inward along the posterior margin. Pile of the abdomen appressed and black in the middle of the tergites, becoming brassy laterally in the female and on the whole of the last tergite. Lateral bristles all pale yellow.

*Holotype:* Male, Uvalde, TEXAS, August 15, 1959. *Allotype* female with the same data, collected in the same field with *Psilocurus reinhardi*, by F. M. Hull.

### ***Psilocurus birdi* Curran**

Five females, Oxford, Mississippi, July 5-14, 1934; 1 female, July 23, 1949.

***Psilocurus birdi* Curran, subspecies *pallustris*, new subspecies**

Female. A large, robust species from 10 to 11 mm. in length. It differs from *Psilocurus birdi* Curran in the female by the abdominal color being quite black with whitish pollinose, lateral triangles. Bristles of the first tergite are black and the hind femur widely encircled by black ventrally leaving only base and apex yellowish.

*Holotype*: Female, Tobitubbe Flood Plain, Lafayette County, MISSISSIPPI, August 6, 1960; 10 *paratype* females, August 6-12, 1960; all collected on leaves of low growing plants; 1 *paratype* female on window of Post Office, University, Mississippi, July 6, 1959.

***Psilocurus nudiusculus* Loew**

One female, July 13, 1956, on gravel on back driveway my home, University, Mississippi.

***Psilocurus reinhardi* Bromley**

Two males and a female collected in a weedy meadow in the city limits of Uvalde, Texas, in deep shade, August 15, 1959. The metallic bluish or purplish color of abdomen of this species is characteristic. Legs of sexes alike or nearly so.

***Psilocurus modestus* Williston**

One male, highway 18, near Damar, Kansas, July 18, 1959.

## On the Immature Stages of the Ptilodactylidae (Coleoptera)

By T. J. SPILMAN, Entomology Research Division, Agriculture  
Research Service, U. S. Department of Agriculture,  
Washington, D. C.

The biology and immature stages of the Ptilodactylidae are seldom mentioned in the literature. The larval stage is described and figured by Böving and Craighead (1930, Ent. Americana 11: 45, pls. 67-69) and by Peterson (1951, Larvae of insects, part 2: 66, fig. C30B). Horion, in volume 4 of his Faunistik der mitteleuropäischen Käfer (Ent. Arb. Mus. Frey, 1955, Sonderband, p. 138), gives a few references. Most of them concern captures in greenhouses containing palms, but one tells of *Ptilodactyla luteipes* Pic, an Indonesian species, being taken from the stem sheath of a banana plant in a European greenhouse. Chapin (1927, Trans. American Ent. Soc. 53: 247) states that *Ptilodactyla exotica* Chapin came ". . . from rose houses. The insect is reported as injurious in both larval and adult stages."

Now more specimens and information have come to light. Adults, a pupa, and larvae of *Ptilodactyla serricollis* (Say) were found in July, 1960, in the soil of a potted India rubber-plant, *Ficus elastica* Roxburgh, which was purchased from a store in Norfolk, Virginia, but which originated in Florida. There was some yellowing of leaves, and later the leaves began to drop off. This continued until the original soil was removed and the roots washed. The plant was then repotted in new soil and kept out of doors. Since that time the plant has made new growth and no further trouble has been evident. The adults were easily determined to species using Chapin's description (*op. cit.*, p. 242), and the larva agreed with the descriptions and pictures given by Peterson (*loc. cit.*).

The pupa of *P. serricollis*, unlike the pupae of many beetles, does not greatly resemble the adult stage, so it might be helpful to describe and illustrate it. Hinton in his fine study on gin-

traps (1946, Trans. Roy. Ent. Soc. London 97: 485, fig. 20) gives a sketch of a pupa labeled *Ptilodactyla* sp., from Brazil. The following is a description of the known pupae of the Ptilodactylidae. Head not visible in dorsal view. Pronotum trapezoidal in outline, with an elongate tubercle on each of four angles. Abdomen with a single gin-trap formed by posterior margin of first tergite and anterior margin of second tergite, this gin-trap without serrations and occupying median two-thirds of the width; tergites 2-6 each with a very short tubercle on lateral areas; tergites 3-7 each with a transverse row of very fine asperities near anterior margin or all without asperities; tergites 2-8 with long setae on posterior margin and shorter setae on disc; segment 9 having two attenuated, posteriorly directed urogomphi which are whitish except at their apices where they seem to be more heavily sclerotized.

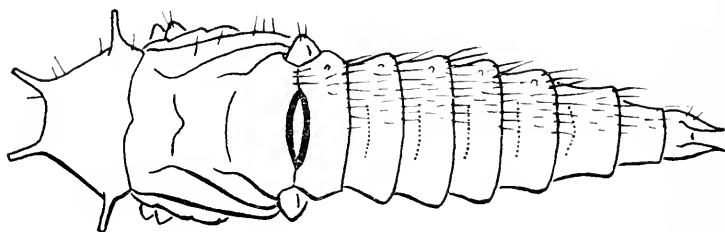

FIG. 1. Dorsal view of pupa of *Ptilodactyla serricollis*.

The asperities mentioned above may be used to separate the pupae of two species of *Ptilodactyla*: *serricollis* has an anterior transverse row of asperities on the median third of abdominal tergites 3-7, whereas *exotica* lacks asperities. The larvae are just as easily separated. The larva of *serricollis* has numerous setae between the anterior and posterior transverse rows of setae on abdominal tergites 1-8, as illustrated by Peterson (*op. cit.*, fig. C30B), and the inner spinose diverticle of segment 10 bears 5 spinose setae. The larva of *exotica* does not have setae between the anterior and posterior transverse rows of setae on abdominal tergites 1-8, as illustrated in Boving and Craighead

(*op. cit.*, pl. 67, fig. I) even though that drawing is labeled as a different species, and the inner spinose diverticle of segment 10 bears 7 or 8 setae.

The larvae and pupae of *exotica* used in this study were submitted with the type series of adults from Melrose, Illinois. Those and the specimens of *serricollis* from Norfolk, Virginia, are in the collection of the U. S. National Museum. I wish to thank Mr. W. F. Walsh, of the U. S. Department of Agriculture, in Roanoke, Virginia, for his help in obtaining the specimens of and data on *serricollis*.

---

### The Type Locality of *Gomphocerus clavatus* Thomas (Orthoptera: Acrididae)<sup>1</sup>

By GORDON ALEXANDER, University of Colorado,  
Boulder, Colorado

In his description of *Gomphocerus clavatus* (in recent literature *Acropeidellus clavatus*), Cyrus Thomas (1873) gave "Kansas" as the locality from which the type specimen came. This locality was apparently not questioned until 1925, Kansas being repeatedly mentioned in the range of the species prior to that time. In 1925, Hebard stated that the type specimen "was apparently mislabelled, as the species may not occur in Kansas and that specimen, showing slight thickening of the cephalic tibiae, very probably came from a high elevation in the Rocky Mountains." The species has apparently never been taken in Kansas, so Hebard's 1925 opinion was reiterated in his later papers.

Caudell, in 1903, placed *Gomphocerus carpenterii* Thomas and *G. clepsydra* Scudder in synonymy with *Gomphocerus clavatus*. Hebard, in several papers (including his review of the Gomphoceri, 1935, in which he erected the genus *Acropeidellus* that now

<sup>1</sup>This study is part of a project made possible by National Science Foundation grant G-5007, here gratefully acknowledged. The author wishes also to thank Ashley B. Gurney and Harold J. Grant, Jr., for critically reading the manuscript.

includes the species in question), concurred in this view. Hebard, did, however, in 1928, suggest the possibility that the high and low altitude forms might be taxonomically distinct, in which case the name *clepsydra* would be available for the low altitude form. Recent studies by the writer demonstrate consistent differences between several populations of *Aeropedellus clavatus*, not merely those from high and low altitudes. It seems desirable, therefore, to designate the type locality with as much restriction as is consistent with the evidence.

Through the courtesy of Dr. Ashley B. Gurney, I had the opportunity a few months ago of examining in the United States National Museum the type specimen of *Gomphocerus clavatus*. The specimen, a male, formerly pinned, is now in a Riker mount. The four separate labels, apparently those that were attached to the pin, are as follows: Type/ Collection C. V. Riley/ Type No. 1036, U.S.N.M./ *Stenobothrus clavatus* Thos. Kansas/ This is the specimen recognized by Hebard (1927) as Thomas's type. The specimen was damaged considerably before being transferred to the present mount. It lacks both antennae, the structures on which the trivial name was based. Both metathoracic legs are missing; and, although the prothoracic legs are present, they are separated from the rest of the specimen.

In the original description, Thomas inserted the name "Dodge" in parenthesis after the locality. This referred to the collector, undoubtedly Charles R. Dodge, from whom Thomas received specimens collected by Dodge on a trip to the Rocky Mountains in the summer of 1871. The type specimen of *Caloptenus Dodgei* of Thomas (= *Melanoplus dodgei*) was collected on that trip. Its type locality was given in the description (Thomas, 1871) as "Pike's Peak, Colorado Territory," and in the final paragraph of the original description the altitude was stated as "about 10,000 feet above the level of the sea." The type specimen (U.S.N.M. No. 727) bears the data "Pike's Peak Col. Ter. 1871." It seems more than probable that the type of *Gomphocerus clavatus* was collected at about the same locality on the same trip (or probably at a little higher elevation, for both species occur commonly above timber line on Pikes Peak).

We know that Dodge collected on Pikes Peak; we have no evidence that he collected elsewhere in the Rocky Mountains. The locality label "Kansas," which is an error, may have been the result of a mistake in labelling or it may have been the careless use of a name that would have been valid a few years earlier. (Kansas Territory, a few years prior to Dodge's trip, did include Pikes Peak.) The likely explanation is that the label was added from memory, some time after Dodge left Colorado on his way east.

In recent comparisons of large series of specimens from scattered populations of *Aeropedellus clavatus* throughout the west my early impression that various populations are distinct was confirmed. It is apparent, for example, that one can distinguish between specimens from Pikes Peak and those from other alpine areas in Colorado. (It is noteworthy, of course, that the alpine areas of Pikes Peak are isolated from other similar areas in the Rockies.) With this in mind it occurred to me that a comparison of significant dimensions of the type specimen with corresponding ones from specimens of various populations, including the population on Pikes Peak, would give us further evidence for the locality from which the type came. In these comparisons, I have found two morphological ratios of more value in characterizing populations than absolute dimensions, although absolute size is quite significant in distinguishing low altitude (larger) specimens from those at high altitudes. The ratios used are: (a), length of the anterior tibia divided by its maximum width; and (b), length of the terminal seven antennal segments divided by the maximum width. (Although the antennae of the type are missing, we have Thomas's statement that the knob involved the last seven segments.) Both tibia and antenna, or either, or neither may be noticeably swollen in the individuals of certain high altitude populations.

In the accompanying table, dimensions (in millimeters) and ratios of dimensions from the type are compared with series of the same sex from various Colorado populations. The length of the type is my measurement. Thomas gave .56 in. for this figure, definitely an error, as was pointed out by Caudell (1903). I have used the dimension Thomas gave for the length

of the hind femur because that structure is missing and his measurement is a probable one. The figures given for the populations are the means and extremes of the numbers examined from each population. Examination of the table shows that the type could have come from the Pikes Peak population. All its dimensions are within the range for that population. It is extremely unlikely, however, that the type came from an alpine population further north (Mount Evans), an alpine population further south (Trinchera Peak), or a foothills population (Boulder). In each case, overall size, combined with the ratio of width to length of the anterior tibia, characterizes a distinct population.

I therefore propose that Pikes Peak, Colorado, at an elevation of 10,000 feet and above, be recognized as the type locality for *Gomphocerus clavatus* Thomas. The grounds for this proposal

TABLE 1.—Means (and Extremes) of Measurements and Ratios from Males of Various Colorado Populations of *Aeropedellus clavatus* (Thomas) Compared with the Same Data from the Type of *Gomphocerus clavatus*. Measurements are in Millimeters. Ratios are L, Length, Divided by W, Width

	Total Length	Pronotum Length	Hind Femur Length	Anterior Tibia L/W	Antennal Knob L/W
Type of <i>Gomphocerus clavatus</i>	17.6	3.3	10	6.1	lost
Pikes Peak 12,900' 20 males	17.1 (15.5-18.5)	3.7 (3.2-4.0)	10 (9.5-10.5)	5.8 (5.3-6.2)	2.2 (1.8-2.8)
Mount Evans 13,100' 26 males	17.7 (16.7-18.5)	3.8 (3.4-4.1)	10.4 (9.6-11.0)	4.2 (3.7-4.8)	1.9 (1.6-2.4)
Trinchera Peak 12,000' 15 males	15.8 (14.8-16.7)	3.5 (3.3-3.8)	9.8 (9.3-10.4)	4.7 (4.4-5.0)	2.4 (2.2-2.6)
Boulder, Colo. foothills 5,800' 20 males	19.1 (18.2-20.7)	3.7 (3.5-4.0)	11.5 (10.9-11.9)	6.9 (5.9-7.9)	3.0 (2.3-3.8)



are three: 1. The validity of Hebard's statement that the locality label was incorrect because the species is unknown in Kansas and because the morphology of the type specimen suggests that it came from high up in the Rocky Mountains. 2. The collector of the type, Charles R. Dodge, collected on Pikes Peak in 1871, and his specimens were available to Thomas. 3. The morphological pattern of the type specimen corresponds with the pattern of specimens from the Pikes Peak population but not with the pattern of specimens from other Colorado populations.

#### LITERATURE CITED

- CAUDELL, A. N. 1903. Notes on Orthoptera from Colorado, New Mexico, Arizona, and Texas, with descriptions of new species. *Proc. U. S. Nat. Mus.* 26: 775-809.
- HEBARD, M. 1925. The Orthoptera of South Dakota. *Proc. Acad. Nat. Sci. Phila.* 77: 33-155.
- . 1927. Fixation of the single types of species of Orthoptera described by Cyrus Thomas. *Proc. Acad. Nat. Sci. Phila.* 79: 1-11.
- . 1928. Orthoptera of Montana. *Proc. Acad. Nat. Sci. Phila.* 80: 211-306.
- . 1935. Notes on the group Gomphocerini and a key to its genera, including one new genus (Orthoptera, Acrididae, Acridiinae). *Entom. News* 46: 184-188, 204-208.
- THOMAS, C. 1871. On a new grasshopper from Colorado. *Canad. Entom.* 3: 168.
- . 1873. Synopsis of the Acrididae of North America. *Rept. U. S. Geol. Surv. of the Territories, Vol. V, Pt. 1.* 262 pp.

---

### Book Notice

STYLE MANUAL FOR BIOLOGICAL JOURNALS. Prepared by the Committee on Form and Style of the Conference of Biological Editors. American Institute of Biological Sciences, 2000 P Street, NW, Washington 6, D. C. \$3.00. Provides necessary technical information and also suggestions that may help improve the style and effectiveness of articles written for biological journals by inexperienced authors, and some others.

# Entomologist's Market Place

## ADVERTISEMENTS AND EXCHANGES

Advertisements of goods or services for sale are accepted at \$1.00 per line, payable in advance to the editor.

Notices of wants and exchanges not exceeding three lines are free to subscribers.

All insertions are continued from month to month, the new ones are added at the end of the column, and, when necessary, the older ones at the top are discontinued.

---

**Butterflies.** Wish to exchange specimens for Japanese species. Please write to Ichiro Nakamura (Boy, age 16), 26 Aza-Nichiyama Obayashi Takarazuka-shi, Hyogo-Ken, Japan.

**Phasmidae** of nearctic area desired alive. Purchase or trade, drawing on large stock of major orders, worldwide. Domminck J. Pirone, Dept. Entomology, Cornell University, Ithaca, N. Y.

**Nitidulidae** and **Rhizophagidae** wanted in exchange for European beetles of all families. O. Marek, Zámberk 797, Czechoslovakia.

**Wanted and Needed.** We are compiling a history of entomology, and particularly, at present, of the amateur insect clubs that flourished 50 to 75 years ago. Will you who have knowledge of such early clubs or societies advise me, giving facts on the time of existence, members, etc., which you may have. J. J. Davis, Dept. of Entomology, Purdue University, Lafayette, Indiana.

**Cockroaches (Blattoidea)** of Japan, Okinawa, Formosa (Taiwan), and the Philippines are being studied in cooperation with Dr. K. Princis. Loans of specimens from that area are desired. A. B. Gurney, U. S. National Museum, Washington 25, D. C.

**Orthoptera. Gryllinae** (except domestic sp.) and **Pyrgomorphinae** of the world wanted in any quantity for work in morphology, taxonomy, cytology, and experimental biology; dry, or in fluid, or living. Write D. K. Kevan and R. S. Bigelow, Dept. of Entomology, McGill University, Macdonald College, Quebec, Canada.

**Beetles** of the world wanted, all species in exchange for American beetles, moths and butterflies. James K. Lawton (age 18), 7118 Grand Parkway, Wauwatosa 13, Wisconsin.

**Used genuine Schmidt boxes**, excellent condition, at less than half price. H. W. Allen, Box 150, Moorestown, N. J.

# Important Mosquito Works

**MOSQUITO ATLAS. Part I. The Nearctic Anopheles, important malarial vectors of the Americas, and *Aedes aegypti* and *Culex quinquefasciata***

**MOSQUITO ATLAS. Part II. The more important malaria vectors of the Old World: Europe, Asia, Africa and South Pacific region**

By Edward S. Ross and H. Radclyffe Roberts

Price, 60 cents each (U. S. Currency) with order, postpaid within the United States; 65 cents, foreign.

---

## KEYS TO THE ANOPHELINE MOSQUITOES OF THE WORLD

With notes on their Identification, Distribution, Biology and Relation to Malaria. By Paul F. Russell, Lloyd E. Rozeboom and Alan Stone

Mailed on receipt of price, \$2.00 U. S. Currency. Foreign Delivery \$2.10.

---

For sale by the American Entomological Society, 1900 Race Street, Philadelphia 3, Pa., U. S. A.

---

## Just Published

### New Classified Price Lists

Available separates from the TRANSACTIONS OF THE AMERICAN ENTOMOLOGICAL SOCIETY and ENTOMOLOGICAL NEWS, and all titles of the Society's MEMOIRS have been catalogued by author in twelve special price lists in the following categories:

Coleoptera	Neuroptera and Smaller Orders
Diptera	Odonata
Hemiptera	Orthoptera-Dermaptera
Hymenoptera	Arachnida and Other Classes
Lepidoptera	Bibliography-Biography
Memoirs	General

Lists will be mailed free upon request. Please state specifically which list or lists you require.

**The American Entomological Society**

1900 RACE STREET

PHILADELPHIA 3, PENNSYLVANIA

## Just Published

### A MONOGRAPH OF THE ORTHOPTERA OF NORTH AMERICA (NORTH OF MEXICO).

Volume I. Acridoidea in part, covering the  
Tetrigidae, Eumastacidae, Tanaoceridae, and Ro-  
maleinae of the Acrididae.

By James A. G. Rehn and Harold J. Grant, Jr.

282 pages of text, with 401 text-figures (including distributional maps)  
and 8 half-tone plates.

This monograph brings into concise form our knowledge of the genera and species of the groups covered—as present in the United States and Canada. In this work the authors have had access to all the important series contained in institutions in North America. This monograph summarizes the detailed conclusions set forth in various collateral publications, as well as other pertinent matter of broader coverage. Almost all existing type material was examined in the course of the work, and, in addition to the published literature, field observations, covering over fifty years of study over a large part of the area treated, were drawn upon in forming the conclusions. Keys to all of the taxonomic entities discussed are presented, and nearly all of the illustrations used are new.

---

Monograph No. 12 of the  
Academy of Natural Sciences of  
Philadelphia

Price \$10.00 postpaid  
(add 10% to cover handling of foreign orders)

---

Publications Department  
ACADEMY OF NATURAL SCIENCES OF PHILADELPHIA  
19th and The Parkway  
Philadelphia 3, Pa., U.S.A.

# ENTOMOLOGICAL NEWS

**MAY 1961**

Vol. LXXII

No. 5

---

**CONTENTS**

Alexander—New exotic crane-flies. Part III ..... 113

Scott—Collembola from Japan. Part III ..... 121

Hays—*Tabanus aranti* sp. nov. from Alabama ..... 127

Emerson and Elbel—A new species of *Rallicola* ..... 130

Hubbard—Fleas from kangaroo rats of N. California ..... 133

Obituaries ..... 132, 139

---

PUBLISHED MONTHLY, EXCEPT AUGUST AND SEPTEMBER, BY  
**THE AMERICAN ENTOMOLOGICAL SOCIETY**  
 PRINCE AND LEMON STS., LANCASTER, PA.  
 AND  
 1900 RACE STREET, PHILADELPHIA 3, PA.

---

Subscription, per yearly volume of ten numbers: \$5.00 domestic; \$5.30 foreign; \$5.15 Canada.  
 Second-class postage paid at Lancaster, Pa.

LIV, INS.  
 U.S. MAIL, 5¢

# ENTOMOLOGICAL NEWS

---

**ENTOMOLOGICAL NEWS** is published monthly, excepting August and September, by The American Entomological Society at Prince and Lemon Sts., Lancaster, Pa., and the Academy of Natural Sciences, 1900 Race Street, Philadelphia 3, Pa., U. S. A.

**PHILIP P. CALVERT**, Editor Emeritus. **R. G. SCHMIEDER**, Editor. Editorial Staff: **H. J. GRANT, JR.**, **E. J. F. MARX**, **M. E. PHILLIPS**, and **J. A. G. REHN**.

**SUBSCRIPTIONS:** Communications and remittances to be addressed to **Entomological News, 1900 Race Street, Philadelphia 3, Pa.**

Prices per yearly volume of 10 numbers.

Private subscriptions, for personal use: in the United States, \$5.00; Canada, \$5.15; other countries, \$5.30.

Institutional subscriptions, for libraries, laboratories, etc.: in the United States, \$6.00; Canada, \$6.15; other countries, \$6.30.

**ADVERTISEMENTS:** Rate schedules available from the editor.

**MANUSCRIPTS** and all communications concerning same should be addressed to **R. G. Schmieder, Zoological Laboratory, University of Pennsylvania, Philadelphia 4, Pa.**

The receipt of all papers will be acknowledged and, if accepted, they will be published as soon as possible. Articles longer than eight printed pages may be published in two or more installments, unless the author is willing to pay the cost of a sufficient number of additional pages in any one issue to enable such an article to appear without division.

**ILLUSTRATIONS:** Authors will be charged as follows: For text-figures, the cost of engraving; for insert plates (on glossy stock), the cost of engraving plus printing. Size limit, when printed, 4 × 6 inches. All blocks will be sent to authors after printing.

**TABLES:** The cost of setting tables will be charged to authors.

**SEPARATA:** Members of the American Entomological Society may elect to receive, gratis, 25 offprints of their contributions. These will be "run-off-form," without removal of extraneous matter.

Those members desiring more than 25 separates, and all non-members, will receive no gratis copies. They must obtain all their separates (as reprints, with extraneous matter removed) from the printer at the prices quoted below. Authors must place their order for such separates with the editor at the time of submitting manuscripts, or when returning proof.

Copies	1-4 pp.	5-8 pp.	9-12 pp.	Covers
50	\$4.35	\$6.96	\$10.88	\$4.74
100	5.21	8.26	13.05	6.48
Add'l 100	1.74	2.60	4.33	3.48

Plates printed one side: First 50, \$3.47; Additional 100's, \$2.61.

Transportation charges will be extra.

# ENTOMOLOGICAL NEWS

VOL. LXXII

MAY, 1961

No. 5

## New Exotic Crane-Flies (Tipulidae: Diptera). Part III

By CHARLES P. ALEXANDER, Amherst, Massachusetts<sup>1</sup>

The preceding part under this general title was published in ENTOMOLOGICAL NEWS, 71: 237-243, 1960. At this time I am describing species from various parts of India, all belonging to the extensive genus *Hexatoma*. The specimens were collected by Dr. Fernand Schmid, to whom I am greatly indebted for many crane-flies from various parts of southern Asia.

### *Hexatoma* (*Hexatoma*) *madrasensis* new species

Size small (wing of female 5.5 mm.); general coloration of mesonotum medium brown, praescutum glabrous; wings weakly tinged with brown, without stigma; veins unusually glabrous;  $Sc_1$  ending some distance before fork of  $R_s$ ,  $R_2$  close to fork of  $R_{2+3+4}$ , *m-cu* at fork of *M*.

♀. Length about 5 mm.; wing 5.5 mm.; antenna about 0.8 mm.

Rostrum and palpi light brown, much reduced. Antennae of female 6-segmented, light brown; first flagellar segment stout basally, gradually tapering to outer end, subequal in length to the succeeding two segments, with delicate pale setae additional to the scattered bristles, the latter longer and more evident on the outer segments. Head dark brown; vertical tubercle large, entire.

<sup>1</sup> Contribution from the Entomological Laboratory, University of Massachusetts.

Mesonotal praescutum and scutum uniformly medium brown, the surface subnitidous, glabrous; posterior sclerites of notum a trifle paler. Pleura light brown, vaguely darker on the anepisternum and ventral sternopleurite. Halteres infuscated, knob large. Legs with coxae and trochanters testaceous brown; remainder of legs yellowish brown, with relatively short setae. Wings weakly tinged with brown, the prearcular and costal fields a trifle more yellowed; stigma lacking; veins pale brown. Veins unusually glabrous, beyond the cord with about five macrotrichia on distal section of  $R_5$ , distributed over the entire length. Venation:  $Sc$  relatively short,  $Sc_1$  ending some distance before fork of  $R_5$ ;  $R_{2+3+4}$  long, with  $R_2$  at or close to fork; veins  $R_3$  and  $R_1$  divergent, cell  $R_3$  at margin only a little less extensive than  $R_2$ ; outer medial veins weak;  $m-cu$  at fork of  $M$ , a little shorter than distal section of  $Cu_1$ .

Abdominal tergites dark brown, sternites somewhat more brightened on central part. Ovipositor with valves only moderately developed, with setae virtually to their tips.

*Habitat.* SOUTH INDIA. *Holotype:* ♀, Veraiyattu Tittu, Madras, 1,500 feet, December 21, 1958 (Fernand Schmid).

This is the first record of occurrence of the typical subgenus in south India. The species is quite distinct from the species known from the western Himalayas, being somewhat more like *Hexatoma (Hexatoma) brevistigma* Alexander, of Thailand. This differs especially in the venation and pattern of the wings, including the evident stigmal area, longer  $Sc$ , and position of vein  $R_2$  well beyond the fork.

### **Hexatoma (Eriocera) perlongata** new species

Size medium (wing 11 mm.); antennae short; vertical tubercle orange, very large, bilobed; thorax brownish black, scutellum obscure yellow; halteres and legs black, femoral bases broadly yellowed; wings infuscated, base conspicuously yellow;  $R_s$  very long,  $R_2$  before the fork, cell  $M_2$  open by atrophy of  $m$ ; abdomen yellowed, hypopygium black.

♂. Length about 10 mm.; wing 11 mm.; antenna about 1.7 mm.

Rostrum obscure yellow, palpi black. Antennae of male 7-



segmented; scape obscure yellow, remainder dark brown; first flagellar segment longer than the succeeding two combined, with subappressed black setae; penultimate segment a trifle exceeding the antepenultimate and about twice the terminal one. Vertex brown posteriorly, summit with a very large orange enlargement, depressed medially in front, forming two conspicuous lobes that are directed cephalad.

Prothorax, mesonotum and scutal lobes brownish black, surface subnitidous, praescutum with sparse delicate setae; scutellum obscure yellow, parascutella and postnotum brownish black. Pleura blackened. Halteres black. Legs with coxae testaceous brown; trochanters yellow; femora black, their bases broadly yellow, including about the basal half on fore and middle legs, approximately two-thirds to three-fourths on posterior pair; tibiae and tarsi black, proximal tarsal segments a little paler. Wings strongly infuscated, wing base and most of cell *Sc* yellowed; pale streaks in centers of certain cells, especially,  $R_1$  and  $R_4$ ; a narrow more whitened line in cell *1st A* immediately behind the posterior half of vein. Veins beyond cord with abundant strong macrotrichia, basad of cord on outer half of  $R_s$ , outer third of  $M$  and a few near outer end of *1st A*. Venation: *Sc* relatively short,  $Sc_1$  ending before fork of  $R_s$ ,  $Sc_2$  near its tip;  $R_s$  very long, at least one-half longer than  $R$ ;  $R_2$  before the radial fork, leaving a short element  $R_{3+4}$ ;  $R_{1+2}$  subequal to  $R_2$ ; cell  $M_2$  open by atrophy of  $m$ , cell  $M_3$  longer than its petiole;  $m-cu$  just beyond the fork of  $M$ .

Abdomen partly destroyed by insect pests; first segment dark brown, intermediate ones obscure yellow; hypopygium and possibly some adjacent segments black.

*Habitat.* SIKKIM. *Holotype:* ♂, Bop, 5,950 feet, July 15, 1959 (Fernand Schmid).

*Hexatoma (Eriocera) perlongata* is a very distinct fly, especially in the venation, as the elongate  $R_s$ , position of  $R_2$  and open cell  $M_2$ . *H. (E.) dharmia* Alexander, of South India, has cell  $M_2$  open by atrophy of basal section of  $M_3$ , differing further in all details of coloration and in other venational features, as the short  $R_s$  and position of vein  $R_2$  beyond the radial fork.

**Hexatoma (Eriocera) vamana** new species

Belongs to the *longicornis* group; size unusually small (wing of male less than 7 mm.); antennae of male about three times the body; general coloration of thorax dark brown, abdomen black; wings suffused with brown, macrotrichia of veins very sparse;  $R_2$  longer than  $R_{1+2}$ , before the radial fork, leaving an element  $R_{3+4}$ ; veins  $R_3$  and  $R_4$  divergent, cell  $R_3$  wide at margin; *m-cu* at near one-third the length of  $M_{3+4}$ .

♂. Length about 5.5 mm.; wing 6.8 mm.; antenna about 18 mm.

Rostrum and mouthparts very reduced, brown; palpi short, black. Antennae of male 6-segmented, very long, approximately three times the body; scape large, brownish yellow; remainder of organ brown, passing into black outwardly; flagellar segments very long, progressively lengthened outwardly; emergence bristles small and scattered, on the outer segments more delicate and hairlike. Head medium brown; vertical tubercle glabrous, large and bulbous, entire.

Pronotum brown. Mesonotum almost uniformly dark brown; praescutal setae long but very sparse. Pleura dark brown. Halteres infuscated, paler at base, knob dark brown. Legs with coxae dark brown; trochanters brownish yellow; remainder of legs dark brown; setae of legs long but sparse (posterior legs broken). Wings suffused with brown, stigmal region vaguely darker; veins brown, outer medial veins pale and delicate. Macrotrichia of veins beyond cord very sparse, with few on  $R_1$  and only two or three at outer end of  $R_5$ ; costal fringe short. Venation:  $R_2$  nearly twice  $R_{1+2}$  and slightly longer than  $R_{3+4}$ ; veins  $R_3$  and  $R_4$  divergent, cell  $R_3$  at margin slightly more extensive than cell  $R_2$ ; cell 1st  $M_2$  subequal in length to distal section of vein  $M_{1+2}$ ; *m-cu* at near one-third the length of  $M_{3+4}$ , longer than distal section of  $Cu_1$ ; cell 2nd  $A$  relatively narrow.

Abdomen, including hypopygium, black.

*Habitat.* SOUTH INDIA. *Holotype:* ♂, Sathupara, Madras, 1,500 feet, December 1, 1958 (Fernand Schmid).

*Hexatoma (Eriocera) vamana* is readily told from other regional members of the *longicornis* group by the small size and venation of the radial field. The specific name, *vamana*, is that of the dwarf incarnation of Vishnu in Hindu mythology.

**Hexatoma (Eriocera) gnava** new species

Belongs to the *longicornis* group; general coloration of thorax brownish gray, praescutum with four brown stripes; antennae of male very long, 6-segmented; legs obscure yellow, posterior tibiae with long pale setae; wings weakly darkened, stigma pale brown, veins glabrous;  $R_{1+2}$  and  $R_2$  subequal,  $R_{2+3}$  about three times  $R_2$ ; valves of ovipositor short and fleshy.

♂. Length about 8–9 mm.; wing 10–11 mm.; antenna about 32–36 mm.

♀. Length about 8–8.5 mm.; wing 10–10.5 mm.; antenna about 1.7 mm.

Rostrum reduced, light brown; palpi very small, black. Antennae of male greatly lengthened, approximately three times the wing; proximal three or four segments yellowish brown, outer segments passing into black; organ apparently 6-segmented, with the terminal segment very long, only a little shorter than the remainder of organ; basal three flagellar segments with small scattered emergence bristles, these becoming more scattered on outer segments, with still fewer and smaller setae on the terminal segment; scape very large, pedicel correspondingly reduced; in female, antennae short, if bent backward not reaching the wing root, apparently 6-segmented. Head chestnut brown, more pruinose behind; vertical tubercle of male very large and tumid, entire, provided with long pale setae on posterior aspect; a blackened area on anterior face behind the scape; tubercle of female much smaller.

Pronotum brownish gray. Mesonotal praescutum brownish gray with four brown stripes, the intermediate pair well separated; posterior sclerites of notum brownish gray, scutal lobes patterned with darker; notal vestiture very abundant, white, erect. Pleura chiefly dark brown, sparsely pruinose, pleuro-

tergite with white setae; dorsopleural membrane darker. Halteres with stem faintly darkened, knob dark brown. Legs with coxae light brown; trochanters brownish yellow; femora obscure yellow, tibiae and tarsi slightly darker; posterior tibiae with abundant long pale setae. Wings weakly darkened, stigma pale brown, ill-delimited; veins dark brown, those of the costal and prearcular fields yellowed. Veins glabrous, beyond cord with a complete but scattered series of small macrotrichia on distal section of  $R_3$ ; no trichia on  $R$ ,  $R_1$  or  $Sc$  except a very few on  $R_1$  in the stigmal area; costal fringe of male short but dense. Venation:  $R_{1+2}$  subequal to or a little longer than  $R_2$ , the latter about one-third  $R_{2+3}$ ;  $m-cu$  shortly beyond fork of  $M$ .

Abdomen, including hypopygium, dark brown, basal tergites a trifle paler. Ovipositor with valves short and fleshy, as in typical *Hexatoma*.

*Habitat.* WEST INDIA. *Holotype*: ♂, Sykes, Bombay, 2,000 feet, February 5, 1959 (Fernand Schmid). *Allotopotype*: ♀, pinned with the type. *Paratopotypes*: 1 ♂, 3 ♀♀.

The closest regional ally of the present fly is the Javanese *Hexatoma (Eriocera) verticalis* (Wiedemann) which differs in coloration of the body and wings and in the venation, especially of the radial field. The present fly presumably is the same species that was recorded from Pusa, Bihar, India by Brunetti (Rec. Indian Mus., 15: 333, 1918).

### *Hexatoma (Eriocera) artifex* new species

Size medium (wing of male 10 mm.); mesothorax black, the notum more opaque, with a large fulvous area on the dorsopleural membrane; legs black, femoral bases narrowly yellowed; wings yellowed, the costal border and seams over virtually all veins brown; cell  $M_1$  lacking; abdomen dull black, vaguely pruinose, second segment chiefly yellow.

♂. Length about 10 mm.; wing 10 mm.; antenna about 2 mm.

Rostrum black, gray pruinose; palpi black. Antennae of male 6-segmented, black, the scape pruinose; first flagellar segment about one-sixth longer than the second, with strong setae, especially beneath; bristles of succeeding segments few and

scattered. Head black, gray pruinose, opaque; vertical tubercle low and rounded.

Entire thorax black, surface of notum nearly opaque, of pleura more polished and clearer black; a large fulvous area on the dorsopleural region above the anepisternum; praescutal vestiture very small and sparse. Halteres black. Legs black, coxae polished; femoral bases narrowly but conspicuously yellow (fore legs broken). Wings with the ground yellowed, much restricted by infuscations in the costal region and as seams over all the veins, the latter more extensive in the outer radial field, least so on basal half of vein  $M$ ; wing base more yellowed, including the veins, remaining veins dark brown. Veins beyond cord with strong macrotrichia, fewer on  $R_{2+3+4}$  and basal section of  $R_5$ , lacking on the two proximal sections of  $M_{1+2}$ ,  $M_{3+4}$  and  $Cu_1$ ; strong trichia on  $Sc$  for most of its extent. Venation:  $Sc$  relatively long,  $Sc_1$  ending about opposite  $r-m$ ;  $R_{2+3+4}$  about twice the basal section of  $R_5$ , or more than twice  $R_{1+2}$ ;  $R_2$  beyond the fork,  $R_{2+3}$  short; cell  $M_1$  lacking but this probably a variable character since the left wing of the unique type shows a marginal remnant in cell  $R_5$  that seems undoubtedly to represent a fragment of  $M_1$ ;  $m-cu$  at or beyond midlength of  $M_{3+4}$ .

Abdomen dull black, vaguely pruinose; much of second segment yellowed, on the sternites this vaguely involving the centers of segments three and four; hypopygium black.

*Habitat.* SOUTH INDIA. *Holotype:* ♂, Swamp Hill, Madras, 7,500 feet, December 13, 1958 (Fernand Schmid).

The nearest relative of the present fly is *Hexatoma (Eriocera) atrodorsalis* (Alexander), likewise from South India, which differs especially in the coloration of the body and the presence of cell  $M_1$ . It should be emphasized that this latter character may prove to be variable in both of these species.

### **Hexatoma (Eriocera) vulpes** new species

Belongs to the *dichroa* group; size large (wing of male over 15 mm.); general coloration fulvous or yellow; head with a conspicuous vertical tubercle; mesonotal praescutum with four fulvous stripes; legs obscure yellow; wings strongly tinged with

fulvous yellow, veins yellow, cell  $M_1$  present; abdomen yellow, the hypopygium darker.

♂. Length about 20 mm.; wing 16.5 mm.; antenna about 3.4 mm.

♀. Length about 20 mm.; wing 14 mm.; antenna about 3 mm.

Rostrum obscure yellow; palpi brownish black. Antennae short in both sexes, 8-segmented; scape and pedicel brown, the former more yellowed beneath, flagellum brownish black; flagellar segments with long coarse setae; first flagellar segment shorter than the succeeding two segments combined. Head dark gray, the conspicuous slender porrect vertical tubercle more blackened, with a second smaller knob immediately cephalad; vestiture of head black, abundant.

Pronotum brownish yellow. Mesonotal praescutum with the restricted ground light brownish gray, with four fulvous stripes that are narrowly bordered by reddish brown, the intermediate pair separated by a capillary line, black in front, paling to brown behind; praescutal vestiture erect, delicate; scutal lobes similarly fulvous, its central area and the scutellum more testaceous; postnotum, including the mediotergite and posterior half of pleurotergite, more yellowed; remainder of the latter, with the pleura, slightly darker, especially above, ventral sternopleurite yellowed. Halteres brownish black, base of stem restrictedly brightened. Legs with coxae reddish, sparsely gray pruinose; trochanters brownish yellow; femora obscure yellow, the tips very narrowly more darkened above; tibiae and tarsi obscure yellow, the last tarsal segment darkened; claws of male with a strong basal spine, in female this smaller and more obtuse. Wings long and narrow, with a strong fulvous brown tinge, more saturated along costal border; stigma lacking; veins yellow, involving the restricted adjoining membrane, more conspicuous on anterior half of wing. Veins of outer radial field, together with  $M_1$  and  $M_2$ , with abundant short macrotrichia, sparse or lacking elsewhere. Venation:  $Sc$  long,  $Sc_1$  ending just beyond  $R_2$ ,  $Sc_2$  a short distance from its tip;  $R_{2+3+4}$  slightly longer than basal section of  $R_5$  or  $R_{2+3}$ ;  $R_{1+2}$  subequal to  $R_{2+3+4}$ ; cell  $M_1$  subequal to its

petiole; cell *1st M*<sub>2</sub> small, subrectangular, with *m-cu* at or beyond midlength; vein *2nd A* long, sinuous.

Abdomen yellow, narrowly darkened laterally; hypopygium more infuscated; segments without differentiated shiny basal rings. Ovipositor with cerci long and very slender.

*Habitat.* SOUTH INDIA. *Holotype:* ♂, Kuttalam, Madras, 500–2,000 feet, November 23, 1958 (Fernand Schmid). *Allotype:* ♀, Krishnappanayakkan, Madras, 1,200 feet, November 30, 1958 (Fernand Schmid).

By Edwards's key to the Old World species of the subgenus *Eriocera* (1921), the present fly runs to couplet 42 where it disagrees with all succeeding species in its coloration, being most similar to *Hexatoma (Eriocera) ferruginosa* (van der Wulp) of Java. This latter fly is quite distinct in all details of coloration and venation.

---

### Collembola from Japan. III. Hypogastrurinae and Neanurinae<sup>1</sup>

By HAROLD GEORGE SCOTT<sup>2</sup>

This paper records six species of springtail insects collected by Captain John E. Scanlon<sup>3</sup> while with the 406th Medical General Laboratory (U. S. Army) in Japan. Specimens will be deposited with the Academy of Natural Sciences, Philadelphia, Pennsylvania.

Subfamily HYPOGASTRURINAE Börner, 1906

*Hypogastrura armata* (Nicolet, 1841).

The Scanlon specimens show the traits which caused Oriental individuals of the species to be designated *H. communis* (Fol-

<sup>1</sup> Part II appeared in Ent. News, 70(9): 241–243.

<sup>2</sup> Training Branch, Communicable Disease Center, Public Health Service, U. S. Department of Health, Education, and Welfare, Atlanta, Georgia.

<sup>3</sup> Medical Service Corps, U. S. Army. Present address: Entomology Department, Walter Reed Army Medical Center, Washington, D. C.

som, 1897). However, I follow Stach (1949, p. 131) in considering *H. communis* a variant of *H. armata*.

ADDITIONAL JAPANESE RECORD. Seven specimens, soil from rodent burrow, 23-x-1952, Shizuoka, Subashiri, Honshu, JAPAN, by J. E. Scanlon. This species was first recorded from Japan by Folsom (1897).

DISTRIBUTION. Holarctic, Neotropical, Australasian.

### *Hypogastrura ununguiculata* (Tullberg, 1869).

JAPANESE RECORD. Five specimens, rodent nest, 7-iii-1952, Tokyo, Honshu, JAPAN, by J. E. Scanlon. This species has not been recorded previously from Japan.

DISTRIBUTION. Holarctic.

### *Hypogastrura japonica* sp. nov. Figure 1.

TYPE COLLECTION. Three specimens, soil from rodent burrow, 23-x-1952, Shizuoka, Subashiri, Honshu, JAPAN, by J. E. Scanlon.

DESCRIPTION. Body elongate, not subglobose, segmentation distinct; setae present, scales and pseudocelli absent; integument minutely granular; color light brown mottled with blue, legs pale brown, fore part of head and antennae heavily mottled with blue; head prognathous; mouthparts chewing, mandible with molar surface; ant III and IV semiconfluent, without eversible sac between them; ant IV tip with sensory seta; ant III sense organ with rods, no cones; postantennal organ with 4 peripheral tubercles, 1 much smaller than other 3; eyes 8 and 8 on dark eyepatches; pronotum not reduced, setaceous, of same texture as other body segments; unguiculus present, about  $\frac{2}{3}$  unguis; unguis and unguiculus without teeth; tenent hairs absent; colophore sacs smooth, small; furcula not ankylosed, reaching almost to colophore; dental thorns absent; mucro spoon-shaped, without teeth; anus terminal; anal spines 2, strongly curved, each about length of hind unguis; body length about 1.2 mm.

DIAGNOSTIC CHARACTERISTICS. This species is clearly a member of the subgenus *Neogastrura* (*sensu* Stach, 1949, p.



19). It may be distinguished from all other members of that group by the absence of dental thorns and of tenent hairs.

NOTE. Although data are identical, specimens of *H. japonica* sp. nov. did not come from the same collection as those of *H. armata*.

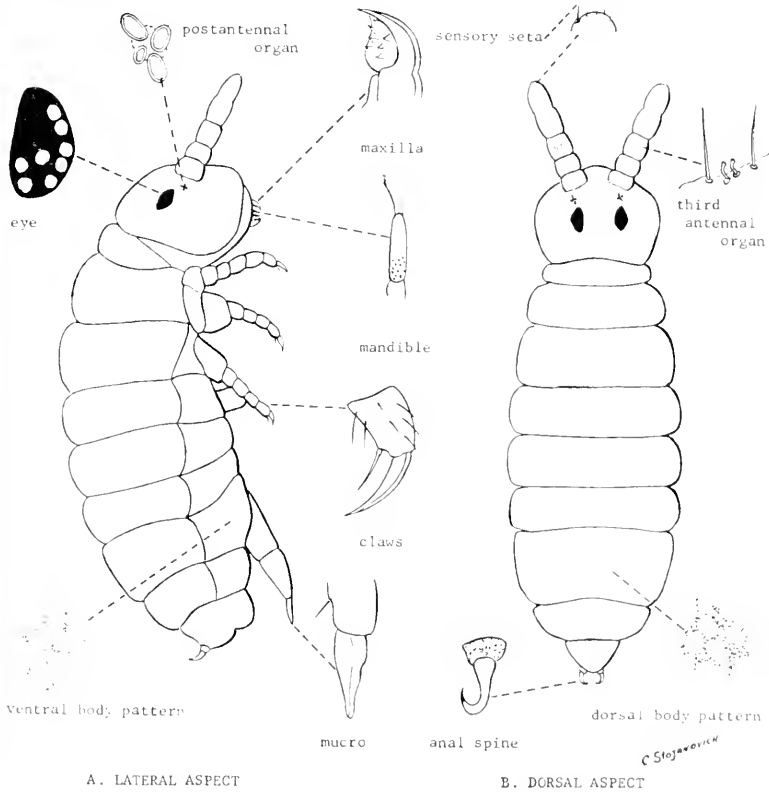

FIG. 1. *Hypogastrura japonica* sp. nov.

Subfamily NEANURINAE Börner, 1901

**Protanura aphoruroides** Yosii, 1953.

ADDITIONAL JAPANESE RECORD. One specimen, soil from rodent burrow, 23-x-1952, Shizuoka, Subashiri, Honshu,

JAPAN, by J. E. Scanlon. This species was first recorded from Japan by Yosii (1953).

DISTRIBUTION. Japan.

*Neanura ornata* Folsom, 1902.

JAPANESE RECORD. Three specimens, rodent nest, 19-iii-1952, Akabane, Honshu, JAPAN, by J. E. Scanlon. This species has not been recorded previously from Japan.

DISTRIBUTION. Japan, Alaska, Siberia.

*Neanura pseudornata* sp. nov. Figure 2.

TYPE COLLECTION. Three specimens, Berlese funnel sample of soil, bamboo grove in woods, 677 meters altitude, 20-vi-1952, Beppu, Oita Ken, Kyushu, JAPAN, by J. E. Scanlon.

DESCRIPTION. Body elongate, not subglobose, segmentation distinct; setae present, scales and pseudocelli absent; integument minutely granular with large reticulated segmental tubercles (head, 11; thorax, 6-8-8; abdomen, 6-8-8-6-4-2); color yellow speckled with brownish-purple, legs darker than rest of body; head prognathous, wider than long, rounded triangular; head tubercles not coalesced; mouthparts suctorial, projecting in a cone; mandible without molar surface; head of maxilla needle-like, without lamellae or teeth; antenna longer than head, segments distinct; ant IV conical; ant III sense organ with sense-rods, without cones or papillae; postantennal organ absent; eyes pigmented, 3 and 3, not on dark eyepatches; pronotum not reduced, setaceous, of same texture as other body segments; unguiculus absent; unguis without teeth; tenent hairs absent; colophore sacs smooth; furcula absent; anal segment large; supra-anal valve bilobed; anal spines absent; body length about 1.1 mm.

DIAGNOSTIC CHARACTERISTICS. This species is close to *Neanura ornata* Folsom, 1902. It may be distinguished from *N. ornata* and other known *Neanura* by the following combination of characters: (1) head wider than long; (2) eyes 3 and 3, pigmented; (3) head tubercles not coalesced.

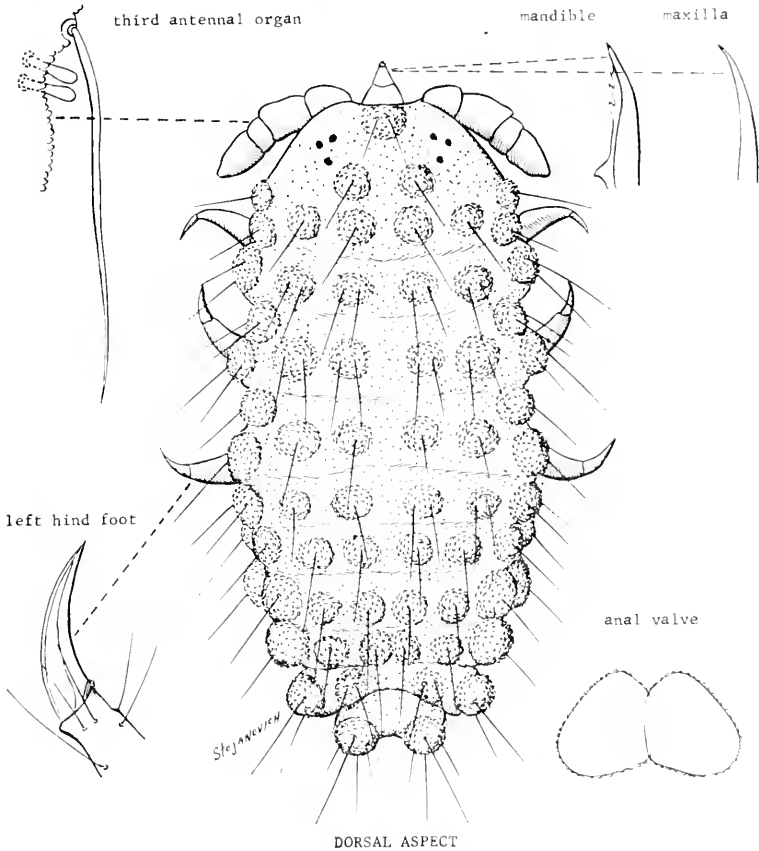

FIG. 2. *Neanura pseudornata* sp. nov.

#### SUMMARY

*Hypogastrura armata*, *H. ununguiculata*, *H. japonica* sp. nov., *Protanura aphoruiroides*, *Neanura ornata*, and *N. pseudornata* sp. nov., are reported from Japan. Of these, only *H. armata* and *P. aphoruiroides* have been recorded previously from the country.

## JAPANESE SUMMARY

(Prepared by Dr. Nobuo Sakurai, Department of Bacteriology, School of Medicine, University of Chiba, Chiba, Japan.)

6種の springtail 昆虫が日本より記録される。すなわち;  
Hypogastrura armata (齧歯類の土穴, 静岡県, 須走, 本州);  
H. ununguiculata (齧歯類の巣, 東京, 赤羽本州); H. japonica sp. nov.  
 (齧歯類の土穴, 静岡県, 須走, 本州); Protanura aphoruroides  
 (齧歯類の土穴, 静岡県, 須走, 本州); Neanura ornata (齧歯類  
 の土穴, 東京, 赤羽, 本州); N. pseudornata sp. nov. (竹やぶの土,  
 大分県, 別府, 九州)。これらのうち, H. armata (= H. communis) あらび  
P. aphoruroides のみがこれまで日本より記録されていた。

## REFERENCES CITED

- BORNER, C. 1906. Mitth. naturh. Mus. Hamburg 23: 147-188.  
 FOLSOM, J. W. 1897. Bull. Essex Inst., Vol. of 1897, 51-57.  
 —. 1902. Proc. Washington Acad. Sci. 4: 87-116.  
 NICOLET, H. 1841. Nouv. Mém. Soc. Helvetia Sci. 6: 1-88.  
 STACH, J. 1949. Acta Monog. Mus. Hist. Nat., Polska Akad. Sci. Lett.,  
 Krakow, ii + 412 pp.  
 TULLBERG, T. 1869. Akad. Afhandl. Upsala, vol. of 1869: 1-20.  
 YOSH, R. 1953. Tenthredo Acta Ent. 2: 348-392.

## ***Tabanus aranti* sp. nov. (Diptera: Tabanidae) from Alabama**

By KIRBY L. HAYS, Department of Zoology-Entomology,  
Auburn University, Auburn, Alabama

The attacks of Tabanidae (horseflies and deerflies) upon cattle present a serious problem in certain sections of Alabama. In 1960, the Auburn Agricultural Experiment Station began a project concerning the ecology and control of these insects. During the spring of 1960, tabanid larvae were collected and 14 species were reared to adulthood. One of these species appears to be undescribed. It is here proposed that this species be called *Tabanus aranti*. The writer wishes to thank C. B. Philip of Hamilton, Montana, for consultation relative to the identity of this species.

### ***Tabanus aranti* sp. nov. (Fig. 1)**

Large; black, with bluish pruinosity; wing darkened, darker along veins; basal callus higher than wide, median callus narrowly joined to basal callus; subcallus pollinose.

Holotype Female.—Length 22 mm. Nine paratype females vary in length from 15 to 22 mm. Eye bare. Frons  $4-4\frac{1}{2}$  times as high as wide, slightly widened above, grayish, darkened at vertex and laterad from median callus. Basal callus higher than wide, black, shiny, and not touching the eyes. Median callus a narrow concolorous line, not widened at juncture with basal callus. Subcallus wrinkled, flatter in profile than *T. wiedemanni*, dark brown pollinose. Clypeus and genae dark brown pollinose with blackish brown hair. Antennae black, first two segments with black hair, third segment black (sometimes reddish tinged basally) with a prominent dorsal angle and deep dorsal excision; annulate portion shorter than basal width. Second palpal segment black with black hair, sharper than palpi of *T. wiedemanni*, moderate in width.

Dorsum and venter of thorax blackish sometimes tinged with red, thin bluish pruinosity anteriorly; hair black. Legs black with concolorous hair. Wings darkened, darker along veins; venation normal. Halteres black, light distally.

Dorsum and venter of abdomen black with bluish pruinosity.

Allotype Male.—Length 17 mm. Paratype males vary from 16 to 20 mm. Like the female except the bluish pruinosity is almost absent and the usual sexual differences. Head as wide or wider than thorax. Enlarged facets of eyes less extensive than in *T. wiedemanni*. Tubercle at vertex distinct, ovoid and slightly raised above the level of the eyes, reddish brown in color. Frontal triangle brownish pollinose, darker brown at the apex. Antennae brownish with black hairs, all portions more slender than in the female; annulate portion of third segment longer than basal width. Terminal palpal segment over 2 times as long as wide, blunt apically. Internal claw of fore tarsus shorter than external. Bluish pruinosity of abdomen much more sparse than in the female.

*Type Material:* Holotype female collected by the author at Auburn, Alabama, June 23, 1958. The allotype, nine paratype females, and eight paratype males were reared from larvae collected from the edge of a small pond on the North Auburn Dairy Research Unit at Auburn, Alabama. All reared material emerged between May 20 and 30, 1960, and are pinned with the pupal case. The holotype was collected on the wing and is believed by the author to best represent the natural characteristics of the species.

The holotype and allotype are deposited in the University of Michigan Museum of Zoology. Male and female paratypes are deposited in the collections of the U. S. National Museum, C. B. Philip, and L. L. Pechuman. The remainder of the material is in the collections of the author. Named for F. S. Arant, a colleague and 1961 President of the Entomological Society of America.

The species appears close to *T. wiedemanni* O. S., but is distinctly larger; median callus, narrow, not widened at juncture with basal callus and with a bluish pruinosity on the body in the female. The male has less extensive areas of large facets of the eye and averages larger in size. The species is also close to *T. nigrescens atripennis* and may be separated from it by the bluish pruinosity of the abdomen, a slightly narrower median callus and less red on the base of the third antennal segment in the female.

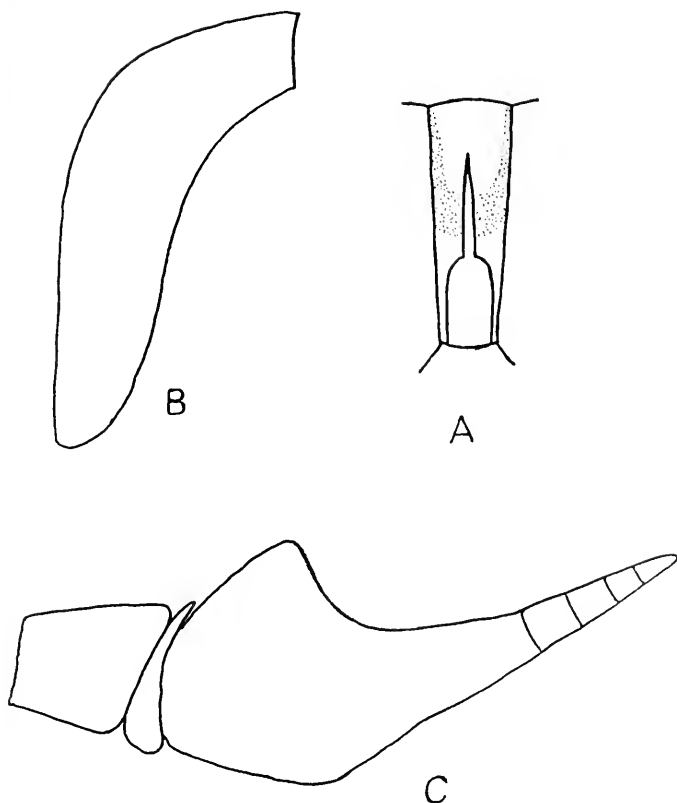

*Tabanus aranti* n. sp., holotype  
A. Front, B. Palpus, C. Antenna.

*Natural History:* The large larvae of this species were collected in the organic ooze common along the shallow edges of southern farm ponds. Cattails and sedges grew in clumps in the vicinity. The edge of the pond was shaded by loblolly pine and sweet gum trees in the late morning and afternoon. No larvae were found in similar unshaded areas around the edges of the same pond. The larvae moved into drier, litter-covered soil and formed a cell somewhat larger than the larva and pupated. The period of pupation was 9 to 12 days.

## A New Species of *Rallicola* (Mallophaga) from Southeast Asia.

By K. C. EMERSON, Stillwater, Oklahoma, and  
ROBERT E. ELBEL, Lawrence, Kansas

A new species of the genus *Rallicola* is herewith described from specimens in the United States National Museum and the British Museum (Natural History), and the probable host for another species is indicated.

### *Rallicola indicus* n. sp.

*Male.* Head as in figure 1. Posterior margin of pterothorax with 3-2-2-3 long setae. Second (first apparent) abdominal tergite interrupted medianly, the remainder transversely continuous. Tergites II-VIII, each with a pair of setae located medianly on the posterior margin. Terminal tergite with 3 long setae on each side. Chaetotaxy of paratergites: II-1, III-IV-2, and V-VIII-3. Abdominal sternites II, VII and VIII, each with 2 long setae; and III, IV, V, and VI, each with 6 long setae. Terminal abdominal segment bilobed with 8 short setae ventrally on each lobe. Genitalia as shown in figure 2.

*Female.* Head, except for filiform antennae, as in the male. Pterothorax as in the male. Abdominal tergites II-VIII interrupted medianly, chaetotaxy as in the male. Chaetotaxy of paratergites as in the male. Chaetotaxy of abdominal sternites: II-III-2, and IV-VI-8. Genital plate with 3 long setae on each side. Posterior margin of vulva with 24 short spines and 28 short setae. Terminal sternite with 16 long lateral setae and 3 genital setae on the tubercle on each side.

Measurements	Male	Female
Length of head	0.55 mm.	0.55 mm.
Width of head	0.41	0.44
Width of prothorax	0.27	0.27
Width of pterothorax	0.37	0.41
Width of abdomen	0.55	0.63
Total length	1.81	2.10

*Diagnosis.* This form is closest to *R. sulcatus* (Piaget, 1880) found on *Hydrophasianus chirurgus* (Scopoli). In the male,



the heavily sclerotized abdominal tergal and sternal plates are not as wide in *R. indicus* as in *R. sulcatus*. The mesosome of the male in *R. sulcatus* is much narrower than in *R. indicus*. In the female, the posterior margin of the vulva in *R. indicus* is normal, or without appendages found in *R. sulcatus*. In both sexes, the ventral chaetotaxy of the genital region is more dense in *R. indicus* than in *R. sulcatus*.

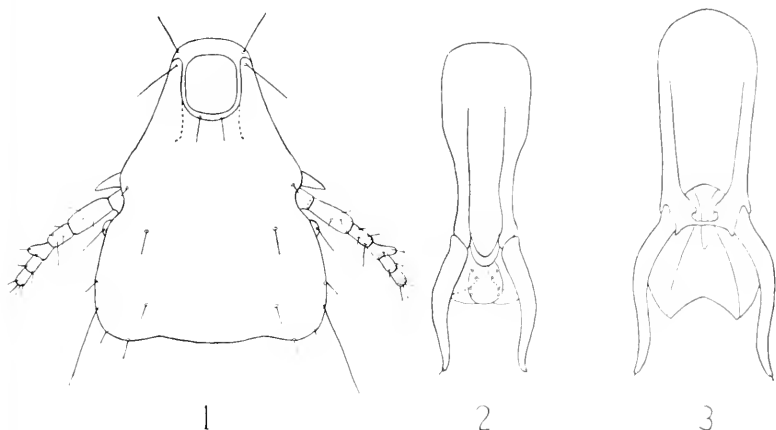

FIG. 1. *Rallicola indicus* n. sp., dorsal view of head, male.

FIG. 2. *Rallicola indicus* n. sp., male genitalia.

FIG. 3. *Rallicola unguiculatus* (Piaget, 1800), male genitalia.

*Type host:* *Metopidius indicus* (Latham).

*Type material:* *Holotype* male, *allotype* female and 30 *paratypes* in the U. S. National Museum collected on 15 December 1952 by Robert E. Elbel at Chaiyaphum, Phu Khieo, Ban Lat, THAILAND. The British Museum (Natural History) has 40 *paratypes* collected in March 1937 at Lucknow, India, and 21 *paratypes* collected on 1 January 1952 at Moraing, Manipur, India.

**Rallicola unguiculatus** (Piaget, 1880)

This species was described from specimens supposedly taken off "*Eurylaimus cucullatus*" from Sumatra. Clay noted "it is possible that *Eurylaimus* is not the true host." Large collections in Thailand from *Centropus sinensis intermedius* (Hume) have yielded specimens which appear to be this species. The male genitalia, of a specimen from this host, is shown in figure 3. Specimens from *Centropus bengalensis bengalensis* (Gmelin), also from Thailand, appear to be the same species. Therefore, it appears that the true host is a species of *Centropus*. Five species of *Centropus* are found on Sumatra. Since material from all of these hosts is not available for study, it is impossible to determine if only one species of *Rallicola* is found on all species of *Centropus*. In the meantime, it can be safely stated that the type host originally given is in error; and it should be *Centropus* sp.

## LITERATURE CITED

- CLAY, T. 1953. Revisions of the genera of Mallophaga. I. The *Rallicola*-complex. Proc. Zool. Soc. Lond. 123: 563-587.

---

## Obituary

Professor Dr. HANS BISCHOFF, formerly curator of Hymenoptera in the Zoological Museum of the Humboldt University in Berlin, and one of the world's foremost hymenopterists, died on March 18, 1960, in the seventy-first year of his age, following a brief illness. Professor Bischoff was best known for his outstanding volume on the biology of the Hymenoptera. His most comprehensive taxonomic contribution was the voluminous monograph of the Mutillidae of Africa.

## Fleas from the Kangaroo Rats of Northern California

By C. ANDRESEN HUBBARD, Tigard 23, Oregon

Just where is Northern California? Usually it is considered to be that part of the state in which the Cascade Mountains are found and one supposes the draws through which highways 299 and 36 extend, via the cities of Eureka, Douglas, Redding, Red Bluff, Chester, Susanville, Lichfield and Wendel and thence out through Flanigan, Nevada, mark the southern limits of northern California. This paper, then, concerns the fleas of the kangaroo rats north of these two highways.

It has been 20 years now since the writer published his first paper on western fleas. During these years he has studied most areas west of the Rocky Mountains with the exception of central and southern California where Gus Augustson, protege of the writer, has been doing a good job in this field.

But in 1953, while the writer was in Iraq on a Fulbright assignment, Augustson wrote in a paper entitled "The flea genus *Meringis* in California" (Bull. So. Calif. Acad. Sci., Vol. 52, part 3, page 111), "Hubbard reports (1947) this species (*Meringis parkeri*) from Modoc County (California) but in view of the specimens reported on below (*Meringis californicus*), his record of a single male may be questionable."

Had Augustson spent even a moment with the range maps on kangaroo rats in Hall's *Mammals of Nevada* (1946), and *Mammals of Oregon* by Bailey (1936) he would have realized that the Merriam and the giant desert kangaroo rats, *D. m. merriami* and *D. d. deserti* travel between Flanigan, Nevada, and Wendel, California, carrying with them always the fleas *Meringis parkeri*, *Meringis dipodomys* and *Trassis (Thrassoides) hoffmani*; that the Surprise Valley kangaroo rat, *D. m. aquilonius*, travels between Cedarville and Eagleville, California, and Sand Creek, Nevada, always carrying with it the flea *Meringis dipodomys* and possibly on occasion the fleas *Meringis parkeri* and *Thrassis (Thrassoides) hoffmani*; that the Northern California kangaroo rat *D. h. californicus* travels back and forth between Dorris,

California, and Worden and Klamath Falls, Oregon, and Tule Lake, California, and Swan Lake, Oregon, and Adel, Oregon, and Fort Bidwell, California, carrying with it always the flea *Meringis cummingi*. In none of these ways or routes is there the slightest terrain difficulty for the ingress or egress of kangaroo rats between northern California and Nevada or Oregon.

The kangaroo rat of northern California which has the greatest range is *Dipodomys merriami merriami*, the Merriam kangaroo rat. Described by Mearns in 1890 from central Arizona, this small dark colored kangaroo rat is found all over western Nevada and at the south tip of Pyramid Lake has its range deflected west to extend through Flanigan, Nevada, into California to be very plentiful about the city dump of Wendel. How far beyond the animal is found the writer does not know, but it is probably confined to Honey Lake Valley.

By working along the well graveled road extending between Wendel and Flanigan (25 miles) the following records were secured:

From *Dipodomys merriami merriami* Mearns (Merriam kangaroo rat), Off 7 hosts as follows: 0-5-0-15-8-1-35 = 63 at city dump, Wendel, Lassen Co., California, November 11, 1960,

*Meringis parkeri* Jordan 1937, 19 males, 25 females,

*Thrassis (Thrassoides) hoffmani* Hubbard 1949, 8 males, 11 females.

Off 4 hosts as follows: 0-6-0-2 = 8 from roadside ditch, 10 miles east of Wendel, California, at large ranch house, November 11, 1960,

*Meringis dipodomys* Kohls 1937, 4 males, 4 females.

Off 16 hosts as follows: 0-5-7-10-12-11-0-25-5-5-5-7-5-5-6-19 = 127 at 16 miles east of Wendel, California, November 11, 1960,

*Meringis parkeri* Jordan 1937, 38 males, 47 females,

*Thrassis (Thrassoides) hoffmani* Hubbard 1949, 21 pairs.

This section of the data brings up three interesting points. First Augustson should not have questioned the writer's earlier records since *Meringis parkeri* is here proved to be well established in northern California. Second, an academic point, how did *Dipodomys m. merriami* get across the Colorado River to

make its way eventually into California? The writer has no idea. Third, where does *Dipodomys m. merriami* pick up its heavy loads of *Meringis parkeri*, which is of course, the true flea of *Dipodomys ordii columbianus*, the Columbian kangaroo rat? Coming in from the south it should carry only *Meringis dipodomys*. The writer believes *Meringis parkeri* is picked up by Merriam's kangaroo rat from the Columbian kangaroo rat where they mix west of Pyramid Lake, Black Rock Desert and Smoke Creek Desert as the Columbian kangaroo rat has come down from Oregon, the state in which much of its range is found.

Largest of all of the western kangaroo rats, *Dipodomys deserti deserti*, the giant desert kangaroo rat, was described by Stephens in 1887 from the Mohave Desert in San Bernardino County, California. It ranges east into southern Nevada, then a good 700 miles to the north in western Nevada to the south end of Pyramid Lake where its range was thought to be deflected to the east but the records here offered show that the range is also deflected to the west, out through Flanigan, Nevada, and through the draw which goes to Wendel, California. These kangaroo rats are lovely, huge, silky, and a beautiful buff.

From work along the Wendel-Flanigan road the following records were secured:

From *Dipodomys deserti deserti* Stephens (giant desert kangaroo rat), Off 2 hosts as follows: 2-2 = 4 at 16 miles east of Wendel, California, November 11, 1960.

*Meringis parkeri* Jordan 1937, 3 males,

*Thrassis (Thrassoides) hoffmani* Hubbard 1949, 1 male.

This section of the data brings to the attention of mammologists that the range of the giant desert kangaroo rat is extended out of northern Nevada into California in the vicinity of Wendel.

The kangaroo rat of northern California with the smallest range is *Dipodomys microps aquilonius*, the Surprise Valley kangaroo rat described by Willets in 1939 from Cedarville, Modoc county, California. This dark colored fairly large kangaroo rat is plentiful about Cedarville, Eagleville, Bare Ranch, and is said to range as far south as Pyramid Lake, Nevada.

This range is about 200 miles long. The writer has taken this kangaroo rat in Surprise Valley for some years and found it always carrying the flea *Meringis dipodomys* with an occasional specimen of *Meringis parkeri*.

At the type locality for the kangaroo rat during October of 1960 the following records were secured:

From *Dipodomys microps aquilonius* Willets (Surprise Valley kangaroo rat), Off 9 hosts as follows: 1-2-4-6-1-0-14-4-4 = 36 at the sand dunes east of dry lake, 6 miles east of Cedarville, Modoc Co., California, October 16, 1960,

*Meringis dipodomys* Kohls 1937, 20 males, 16 females.

The fourth kangaroo rat found in northern California is *Dipodomys hermanni californicus*, the Northern California kangaroo rat described by Merriam in 1890 from Ukiah, Mendocino county, California. It is a fairly large kangaroo rat, and dark colored. It is the only one of the series, here offered, which has no contact with the southern forms so carries only its own flea, *Meringis cummingi*. In the some twenty or more years that the writer has been taking this fine animal in the Modoc Lava Beds of California and Swan Lake Valley of Oregon never has he taken strays or other kangaroo rat fleas off it.

From the type locality at Ukiah it ranges into northern California and is found in all kangaroo rat country in the north of the state to penetrate into Oregon at Klamath Falls, spread to the east finally to enter California again to be found in Surprise Valley at Fort Bidwell.

Working along the north boundary of the state, the writer secured these records:

From *Dipodomys hermanni californicus* Merriam (Northern California kangaroo rat), Off 1 host as follows: 2 at Petroglyph Point, Tule Lake, Modoc County, California, November 10, 1960,

*Meringis cummingi* C. Fox 1926, 1 male, 1 female.

Off 3 hosts as follows: 5-3-16 = 24 at 4 miles east of Modoc Lava Beds Headquarters from rock outcrops along road, Tule Lake, California, October 10, 1960,

*M. cummingi* C. Fox 1926, 12 males, 12 females.

Off 7 hosts as follows: 6-2-0-12-2-0-0 = 22 at 3 miles north-east, Fort Bidwell, California, October 17, 1960,

*M. cummingsi* C. Fox 1926, 11 pairs.

Off 2 hosts as follows 2-2 = 4 at 8 miles northeast of Fort Bidwell, California, rock outcrop on Fort Bidwell-Adel road, October 17, 1960,

*M. cummingsi* C. Fox 1926, 4 males.

This section of the data brings to the attention of mammologists the extension of the range of this kangaroo rat by some 100 miles to the east to be recorded from Surprise Valley, Modoc county an area east of Warner Mountains from which it had not before been reported.

In a letter dated December 8, 1960, Dr. Seth Benson, mammologist at the University of California informs the writer that he and a field crew sampled this same Flanigan-Wendel area for kangaroo rats during the summer of 1960 and that during their work in this draw took the following five species; *D. deserti deserti*, *D. merriami merriami*, *D. microps aquilonius*, *D. panamintinus leucogenys* and *D. ordii columbianus*.

So one can say at this time, then, that the fifth kangaroo rat of northern California is *Dipodomys panamintinus leucogenys*, the Panamint kangaroo rat described by Grinnell during 1919 from materials taken in Mono county, California. Its range may be 200 miles long extending along the Nevada-California boundary 100 miles south and north of Lake Tahoe to enter northern California through the Flanigan-Wendel draw. In size this kangaroo rat is large, next to *D. deserti*, and is dark in color. In northern California it probably does not range out of Honey Lake Valley.

Coming in from the south as this animal does, it probably usually carries the fleas *Meringis dipodomys* and *Thrassis (Thrassoides) hoffmani* and because it associates in its northern range with *D. ordii* it would also carry an occasional *Meringis parkeri*.

The sixth of the kangaroo rats of northern California is *Dipodomys ordii columbianus*, the Columbian five-toed kangaroo rat described by Merriam during 1894 from specimens collected in Umatilla county, Oregon. This, the most northern of the kangaroo rats, is beautiful, medium sized, soft buff colored. It ranges in all kangaroo rat country of Oregon and to

the east, all over northern Nevada and from northwest Nevada into California to be found in many parts of Modoc county. This kangaroo rat always carries the flea *Meringis parkeri*.

The kangaroo rat fleas of northern California are then the following four.

*Meringis parkeri* was described by Dr. Karl Jordan of the British Museum, late dean of the world flea students, during 1937 from materials taken at Powderville, Montana. The writer has collected this flea in all the kangaroo rat country of Washington, Oregon, Idaho, Utah, and as far south as Carson City, Nevada, and again from northeast California. The flea's major host is the Columbian kangaroo rat. This is a flea of northern kangaroo rats.

*Meringis dipodomys* was described by Glenn Kohls of the Rocky Mountain Laboratory in 1938 from materials collected in Imperial and Inyo counties, California, off kangaroo rats. The writer has records for this flea from all over Nevada as far north now as Flanigan and Wendel and Cedarville, California. This is a flea of kangaroo rats of the southwest.

*Meringis cummingi* was described by Carol Fox in 1926 from a single male taken off a giant desert kangaroo rat taken in the vicinity of Los Angeles. The writer described the female during 1940 from materials taken off kangaroo rats captured in the Modoc Lava Beds of northern California. The writer has taken this flea throughout the entire portion of its northern range, its entire range seemingly to be central and northern California. The Northern California kangaroo rat seems to be its chief host.

*Thrassis (Thrassoides) hoffmani* was described by the writer during 1949 from materials taken off a giant desert kangaroo rat captured at Beatty, Nevada. This is a common winter flea of southwest kangaroo rats but the new data offered herewith extends the range northwards to Flanigan, Nevada, and northeast California.

It should be remembered by investigators in the field that during hot, dry late June, July, August, and early September few fleas are to be found on kangaroo rats but frequently during other seasons many can be collected from them.



Since Augustson in his paper of 1953 suggested that the writer's records of *Meringis parkeri* from northern California might be instead *Meringis californicus* the specimens of the November, 1960, catches were sent to Frans Smit of the British Museum who determined them as true *Meringis parkeri*.

The flea specimens involved in this paper are being sent for the most part to the United States National Museum and the British Museum with samples going to Public Health Service Laboratories in the west, museums of California, and of course to Mr. Augustson.

The host specimens here involved were shipped alive to Dr. Murray Johnson, surgeon of Tacoma, Washington, who acts by avocation as Curator of Mammals, University of Puget Sound, where he is working under a National Science Foundation grant on "serum protein and hemoglobin electrophoresis of mammals." Upon completion of these tests the host specimens are made into skins and added to the Museum collection where they can be viewed and studied.

This is the third of a series of papers on western fleas to be published by the writer under National Science Foundation Grant B8645.

---

### Obituary

DR. BENTLEY BALL FULTON, Professor Emeritus in Entomology at North Carolina State College, died December 8, 1960. Born in 1889 he attended Ohio State University, received his Master's degree from Chicago, and his Doctorate from Iowa State University. He served as entomologist at the State experiment stations in New York, Oregon and Iowa, after which, in 1928 he accepted a professorship at North Carolina. Dr. Fulton was known among other things for his original work in distinguishing species of crickets by their songs as well as by morphological characters.

# Entomologist's Market Place

## ADVERTISEMENTS AND EXCHANGES

Advertisements of goods or services for sale are accepted at \$1.00 per line, payable in advance to the editor.

Notices of wants and exchanges not exceeding three lines are free to subscribers.

All insertions are continued from month to month, the new ones are added at the end of the column, and, when necessary, the older ones at the top are discontinued.

---

**Butterflies.** Wish to exchange specimens for Japanese species. Please write to Ichiro Nakamura (Boy, age 16), 26 Aza-Nichiyama Obayashi Takarazuka-shi, Hyogo-Ken, Japan.

**Phasmidae** of nearctic area desired alive. Purchase or trade, drawing on large stock of major orders, worldwide. Domminck J. Pirone, Dept. Entomology, Cornell University, Ithaca, N. Y.

**Nitidulidae and Rhizophagidae** wanted in exchange for **European** beetles of all families. O. Marek, Zámberk 797, Czechoslovakia.

**Wanted and Needed.** We are compiling a history of entomology, and particularly, at present, of the amateur insect clubs that flourished 50 to 75 years ago. Will you who have knowledge of such early clubs or societies advise me, giving facts on the time of existence, members, etc., which you may have. J. J. Davis, Dept. of Entomology, Purdue University, Lafayette, Indiana.

**Cockroaches (Blattoidea)** of Japan, Okinawa, Formosa (Taiwan), and the Philippines are being studied in cooperation with Dr. K. Princis. Loans of specimens from that area are desired. A. B. Gurney, U. S. National Museum, Washington 25, D. C.

**Orthoptera. Gryllinae** (except domestic sp.) and **Pyrgomorphae** of the world wanted in any quantity for work in morphology, taxonomy, cytology, and experimental biology; dry, or in fluid, or living. Write D. K. Kevan and R. S. Bigelow, Dept. of Entomology, McGill University, Macdonald College, Quebec, Canada.

**Beetles** of the world wanted, all species in exchange for American beetles, moths and butterflies. James K. Lawton (age 18), 7118 Grand Parkway, Wauwatosa 13, Wisconsin.

**Used genuine Schmidt boxes**, excellent condition, at less than half price. H. W. Allen, Box 150, Moorestown, N. J.

# Important Mosquito Works

**MOSQUITO ATLAS. Part I. The Nearctic Anopheles, important malarial vectors of the Americas, and *Aedes aegypti* and *Culex quinquefasciata***

**MOSQUITO ATLAS. Part II. The more important malaria vectors of the Old World: Europe, Asia, Africa and South Pacific region**

By Edward S. Ross and H. Radclyffe Roberts

Price, 60 cents each (U. S. Currency) with order, postpaid within the United States; 65 cents, foreign.

---

## KEYS TO THE ANOPHELINE MOSQUITOES OF THE WORLD

With notes on their Identification, Distribution, Biology and Relation to Malaria. By Paul F. Russell, Lloyd E. Rozeboom and Alan Stone

Mailed on receipt of price, \$2.00 U. S. Currency. Foreign Delivery \$2.10.

---

For sale by the American Entomological Society, 1900 Race Street, Philadelphia 3, Pa., U. S. A.

---

## Just Published New Classified Price Lists

Available separates from the TRANSACTIONS OF THE AMERICAN ENTOMOLOGICAL SOCIETY and ENTOMOLOGICAL NEWS, and all titles of the Society's MEMOIRS have been catalogued by author in twelve special price lists in the following categories:

Coleoptera	Neuroptera and Smaller Orders
Diptera	Odonata
Hemiptera	Orthoptera-Dermoptera
Hymenoptera	Arachnida and Other Classes
Lepidoptera	Bibliography-Biography
Memoirs	General

Lists will be mailed free upon request. Please state specifically which list or lists you require.

**The American Entomological Society**  
1900 RACE STREET  
PHILADELPHIA 3, PENNSYLVANIA

## Just Published

### A MONOGRAPH OF THE ORTHOPTERA OF NORTH AMERICA (NORTH OF MEXICO).

Volume I. Acridoidea in part, covering the  
Tetrigidae, Eumastacidae, Tanaoceridae, and Ro-  
maleinae of the Acrididae.

By James A. G. Rehn and Harold J. Grant, Jr.

282 pages of text, with 401 text-figures (including distributional maps)  
and 8 half-tone plates.

This monograph brings into concise form our knowledge of the genera and species of the groups covered—as present in the United States and Canada. In this work the authors have had access to all the important series contained in institutions in North America. This monograph summarizes the detailed conclusions set forth in various collateral publications, as well as other pertinent matter of broader coverage. Almost all existing type material was examined in the course of the work, and, in addition to the published literature, field observations, covering over fifty years of study over a large part of the area treated, were drawn upon in forming the conclusions. Keys to all of the taxonomic entities discussed are presented, and nearly all of the illustrations used are new.

---

Monograph No. 12 of the  
Academy of Natural Sciences of  
Philadelphia

Price \$10.00 postpaid  
(add 10% to cover handling of foreign orders)

---

Publications Department  
ACADEMY OF NATURAL SCIENCES OF PHILADELPHIA  
19th and The Parkway  
Philadelphia 3, Pa., U.S.A.

# ENTOMOLOGICAL NEWS

**JUNE 1961**

Vol. LXXII

No. 6

---

## CONTENTS

Eads—Phallic structures in Cyrtacanthracidinae .....	141
McFadden—Improved Berlese technique .....	150
Dennis—Telamonas oviposition behavior .....	152
Crabill—Concerning Neogeophilidae .....	155
Philip—Change of name in Chrysops .....	160
Linsley—New cerabycids from California .....	163
Kramer—Herpetomonas muscarum in the haemocoel .....	165
Symposium .....	166
New subscription rates announced .....	167

---

PUBLISHED MONTHLY, EXCEPT AUGUST AND SEPTEMBER, BY  
THE AMERICAN ENTOMOLOGICAL SOCIETY  
PRINCE AND LEMON STS., LANCASTER, PA.

AND  
1900 RACE STREET, PHILADELPHIA 3, PA.

---

Subscription, per yearly volume of ten numbers: \$5.00 domestic; \$5.30 foreign; \$5.15 Canada.  
Second-class postage paid at Lancaster, Pa.

# ENTOMOLOGICAL NEWS

---

**ENTOMOLOGICAL NEWS** is published monthly, excepting August and September, by The American Entomological Society at Prince and Lemon Sts., Lancaster, Pa., and the Academy of Natural Sciences, 1900 Race Street, Philadelphia 3, Pa., U. S. A.

**PHILIP P. CALVERT**, Editor Emeritus. **R. G. SCHMIEDER**, Editor. Editorial Staff: **H. J. GRANT, JR.**, **E. J. F. MARX**, **M. E. PHILLIPS**, and **J. A. G. REHN**.

**SUBSCRIPTIONS:** Communications and remittances to be addressed to **Entomological News, 1900 Race Street, Philadelphia 3, Pa.**

Prices per yearly volume of 10 numbers.

Private subscriptions, for personal use: in the United States, \$5.00; Canada, \$5.15; other countries, \$5.30.

Institutional subscriptions, for libraries, laboratories, etc.: in the United States, \$6.00; Canada, \$6.15; other countries, \$6.30.

**ADVERTISEMENTS:** Rate schedules available from the editor.

**MANUSCRIPTS** and all communications concerning same should be addressed to **R. G. Schmieder, Zoological Laboratory, University of Pennsylvania, Philadelphia 4, Pa.**

The receipt of all papers will be acknowledged and, if accepted, they will be published as soon as possible. Articles longer than eight printed pages may be published in two or more installments, unless the author is willing to pay the cost of a sufficient number of additional pages in any one issue to enable such an article to appear without division.

**ILLUSTRATIONS:** Authors will be charged as follows: For text-figures, the cost of engraving; for insert plates (on glossy stock), the cost of engraving plus printing. Size limit, when printed, 4 × 6 inches. All blocks will be sent to authors after printing.

**TABLES:** The cost of setting tables will be charged to authors.

**SEPARATA:** Members of the American Entomological Society may elect to receive, gratis, 25 offprints of their contributions. These will be "run-off-form," without removal of extraneous matter.

Those members desiring more than 25 separates, and all non-members, will receive no gratis copies. They must obtain all their separates (as reprints, with extraneous matter removed) from the printer at the prices quoted below. Authors must place their order for such separates with the editor at the time of submitting manuscripts, or when returning proof.

Copies	1-4 pp.	5-8 pp.	9-12 pp.	Covers
50	\$4.35	\$6.96	\$10.88	\$4.74
100	5.21	8.26	13.05	6.48
Add'l 100	1.74	2.60	4.33	3.48

Plates printed one side: First 50, \$3.47; Additional 100's, \$2.61.  
Transportation charges will be extra.

# ENTOMOLOGICAL NEWS

Vol. LXXII

JUNE, 1961

No. 6

## The Terminology of Phallic Structures in the Cyrtaacanthacridinae (Orthoptera, Acrididae)

DAVID C. EADES,<sup>1</sup> Academy of Natural Sciences  
of Philadelphia

There have been three major studies of the phallic structures of grasshoppers, the first by Snodgrass in 1935, the second by Roberts in 1941, and the third by Dirsh in 1956. In his paper Roberts presented a terminology which unified, so far as practical, the terminology of Snodgrass and the isolated earlier works. This terminology was almost universally accepted until 1956 when Dirsh made several basic changes. In papers appearing since 1956 the terminology has been confused; some authors followed Roberts, others followed Dirsh, and Hubbell (1960)<sup>2</sup> modified Dirsh's terms. However, none of the authors since 1956 discussed reasons for his choice of terms. This confusion makes it obvious that more work is needed. A thor-

<sup>1</sup> The author wishes to express his appreciation to James A. G. Rehn and H. Radelyffe Roberts for their generous help and encouragement in the preparation of this paper. Also, V. M. Dirsh, T. H. Hubbell, and Ashley B. Gurney have read the manuscript and offered many valuable comments.

<sup>2</sup> In fairness to Hubbell it should be stated that the study of the terminology of phallic structures was entirely incidental to the purpose of his paper and that a critical analysis of terms was not intended. Nevertheless, his paper is discussed here because he originated terms and, in the case of the arch and the zygoma, it helps to demonstrate that when previous definitions are not sufficiently precise, terms can gradually change meanings without authors being aware of it.

ough analysis of homologies among the various groups of grasshoppers would be highly desirable, but to prepare such an analysis would be an undertaking of major proportions. Rather than abide with the present confused situation until homologies have been established, the present paper undertakes the more modest task of trying to stabilize terminology in a single subfamily, the subfamily Cyrtacanthacridinae (= Catantopinae). The phallic structures of the Acridinae are sufficiently similar that homologies are apparent, but this latter subfamily is not specifically included because the author has done very little work in it. These two subfamilies comprise the dominant groups of grasshoppers of the world and, with respect to the phallic structures, the best known. As homologies of structures of other groups become better understood, this terminology can be applied to them or modified as necessary. In most cases the terms of Roberts are selected as more appropriate than those of Dirsh and better known and less cumbersome than those of Snodgrass. In several cases, however, it is necessary to incorporate modifications of Snodgrass' terms to allow distinctions not provided for by more recent authors. For specific examples of the new terminology, see papers by Rehn and Eades (*Notulae Naturae* No. 345 and *Proc. Acad. Nat. Sci. Phila.*) and Gurney and Eades (*Trans. Amer. Ent. Soc.*) now in press.

It is sometimes useful to visualize the phallus in terms of concentric rings of indentation and lobes of ectoderm. All sclerotized structures must develop in ectoderm, and the homologies of sclerites may best be understood by determining what portion of the ectoderm is involved. All the major authors understood these principles and made use of them in a number of places. Nevertheless, more rigorous use of them would have saved a number of errors. To facilitate discussion, let us begin in the center and proceed outward using the analogy of concentric folds. This is done for convenience in presentation and is not intended to imply any basic radial symmetry. "Indentation" and "lobe" refer to the final result without implying developmental processes.



## CENTRAL INVAGINATION—THE ENDOPHALLIC MEMBRANE

Snodgrass made a useful distinction which has been lost by all subsequent authors. His *apical processes of aedeagus* were structures which projected around the posterior opening of the phallosome. On the other hand, he used *lateral sclerites of phallosome cleft* for the solidly sclerotized structures in the phallosome membrane. I will use *dorsal* and *ventral aedeagal sclerites* for these solidly sclerotized structures, which are totally derived from endophallic membrane but commonly extend into the projecting lobes (see Fig. 1). For the lobes I will use the terms *dorsal* and *ventral aedeagal valves*. The aedeagal valves may be membranous, sclerotized, or partly sclerotized and are derived from both ectophallic and endophallic membrane. *Dorsal* and *ventral* are used in relation to "normal" positions. In forms which are strongly modified, the dorsal aedeagal sclerites may be recognized by their being continuous with the arch. The dorsal and ventral aedeagal valves may be recognized by the fact that they contain the distal portions of, respectively, the dorsal and ventral aedeagal sclerites. As Dirsh points out (*in litt.*), *aedeagus* is a general term for the distal part of the whole phallic complex and would therefore include any distal projection. However, for the sake of conforming as nearly as possible to past usage, I prefer to restrict *aedeagal valves* to structures at the distal end of the phallosome. If there should be any need for the broader sense, something such as "aedeagal lobes" may be defined and used.

In view of the considerable confusion regarding these structures, a list of terms of various authors seems useful. *Dorsal aedeagal sclerites*: anterior (dorsal) lateral sclerites of phallosome cleft of Snodgrass; dorsal aedeagal valves in part of Roberts; valves of cingulum in part of Dirsh as used in his Pauliniidae and Acrididae; dorsal penial valves in part of Hubbell. *Dorsal aedeagal valves*: anterior (dorsal) apical processes of aedeagus of Snodgrass; for remaining authors the same terms as listed above for dorsal aedeagal sclerites. *Ventral aedeagal sclerites*: posterior (ventral) lateral sclerites of phallosome cleft of Snodgrass; ventral aedeagal valves in part

of Roberts; apical valves of penis in part of Dirsh and of Hubbell. *Ventral aedeagal valves*: posterior (ventral) apical process of aedeagus of Snodgrass; ventral aedeagal valves in part of Roberts; apical valves of penis in part of Dirsh and of Hubbell.

With these terms defined, it is now possible to discuss Dirsh's objections to Roberts' terms, primarily to Roberts' use of *dorsal aedeagal valves*. Dirsh stated (p. 231): "From the zygoma region of the cingulum (Pl. 2, fig. 5) or from the arch (Pl. 2, fig. 9) there often arises a pair of valves, situated above the penis valves and parallel to them. Snodgrass (1935) and Radclyffe-Roberts (1941) called them the dorsal valves of the aedeagus, but they actually belong to the cingulum." In the case of the Romaleinae, however, Dirsh substituted *appendices of aedeagus* for *dorsal aedeagal valves*. In his definition Dirsh stated (p. 226) that the *valves of cingulum* are "morphologically derived from the ectophallus." The basic points of disagreement are whether the dorsal aedeagal sclerites are derived from endophallic or ectophallic membrane and whether or not the arch is part of the cingulum. Dirsh stated (p. 227, definition of *penis*, which in the sense of Dirsh includes the ventral aedeagal sclerites as here understood) that the ventral aedeagal sclerites are derived from endophallic membrane. Nevertheless, he maintained that the dorsal aedeagal sclerites (included in his concept of *valves of cingulum*) are ectophallic. This would require that the ventral portion of the phallosome is endophallic and the dorsal portion ectophallic or else that a diverticulum develops from the ectophallic membrane, grows down what is to be the arch, and expands to form the dorsal aedeagal sclerites, which fuse with the phallosome membrane. Both of these interpretations are strongly contradictory to the apparent situation and to the concepts of previous authors. In many cases the arch and dorsal aedeagal sclerites form a continuous sclerite which is not continuous with the cingulum (except by membrane). (See the description of a new species of *Leptyma* in Rehn and Eades, *Proc. Acad. Nat. Sci. Phila.*, in press.) The only evidence which tends to support Dirsh is the possible

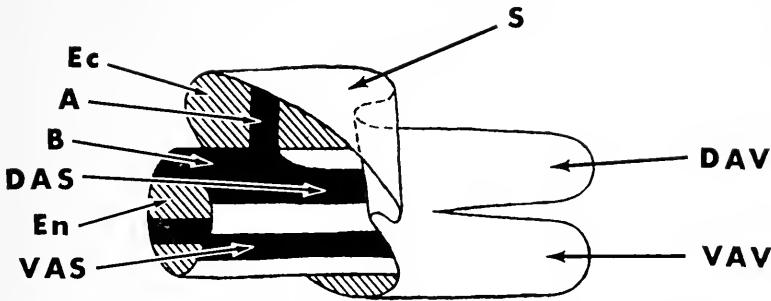

FIG. 1. Diagram of the distal portion of the phallus of a typical grasshopper of the subfamily Crytacanthacridinae (dorsal and ventral phallostreme clefts not shown). A, arch. B, bridge. DAS, dorsal aedeagal sclerite. DAV, dorsal aedeagal valve. Ec, ectophallic membrane. En, endophallic membrane. S, sheath. VAS, ventral aedeagal sclerite. VAV, ventral aedeagal valve.

homology of the dorsal aedeagal sclerites to the *valves of cingulum* in his Charilaidae, Proscopiidae, and Pyrgomorphidae. Such a homology would be dubious on anatomical grounds alone, but the phylogeny of Dirsh (or anyone else) shows his *valves of cingulum* to be of clearly polyphyletic origin (unless they were retained from the common ancestor of the entire superfamily, which is most unlikely). Therefore Dirsh's interpretation with respect to the dorsal aedeagal sclerites in his Acrididae and Pauliniidae should be rejected.

Another term with a confused history is *arch*, although in this case there is no indication that any author was aware of any change in the use of the term. Snodgrass stated (p. 64) that the dorsal aedeagal sclerites "are connected with each other by a strong transverse arch (*t*) in the dorsal wall of the passage," i.e., the phallostreme. This description applied to his *bridge of anterior phallostreme sclerites* as indicated by the fact that he gave this term in his explanation of "*t*" in the set of drawings to which he referred in the above quotation. Roberts defined his *arch of dorsal valves* (p. 241) as a connection between the dorsal aedeagal sclerites and the zygoma of the cingulum and considered the *bridge of anterior phallostreme sclerites* of Snodgrass as a synonym. The *bridge* of Snodgrass connects right

and left dorsal aedeagal sclerites and develops in the dorsal portion of the phallotreme membrane and spermatophore sac. The *arch* of Roberts connects ventrally with the dorsal aedeagal sclerites and the bridge and extends dorsad, usually fusing to the mid-dorsal region of the cingulum. In the forms for which I have made detailed dissections, it is derived from the anterior end of the dorsal phallotreme cleft (the cleft between the dorsal aedeagal valves). The bridge and the arch are often fused so closely that the distinction is rather trifling. Nevertheless, the distinction is useful for descriptive purposes, and the ontogenetic origin is different. The bridge, arch, and dorsal aedeagal sclerites are continuous portions of a single sclerite which has not been named.

Dirsh defined his *arch of cingulum* (p. 225) in the same sense as the *arch of dorsal valves* of Roberts; however, most of his figures were labelled in such a way as to suggest the bridge rather than the arch. Hubbell, apparently working from Dirsh's figures, labelled what is clearly the bridge (fig. 1b, p. 30) as the *arch*. The true arch was labelled as the *attachment to zygapophysis*. I am unable to find any definition of *zygapophysis*, but I would presume it referred to a ventral diverticulum from the zygoma. The existence of such a diverticulum is implied by the terminology of Dirsh, but I know of no evidence to indicate that it actually does exist.

The spermatophore sac possesses a single pair of sclerites, the *endophallic plates*. Dirsh and Hubbell referred to these as *basal valves of penis*, but this term should also be rejected for the sake of consistent terminology. The term *endophallic plate* refers to the entire sclerite but has often been used for certain portions of it in spite of the fact that Snodgrass provided the necessary terms. He referred to the flared anterior portion as the *anterior apodeme of endophallic plate*, but *endophallic apodeme* is adequate. The central portion lying against the spermatophore sac is the *lateral plate*.

#### FIRST RING OF LOBES

This ring includes the aedeagal valves as redefined above. The inner sides are part of the phallotreme membrane and may

or may not be sclerotized. The outer sides are part of the ectophallic membrane and are often coriaceous but normally not sclerotized unless fused to the aedeagal sclerites.

#### FIRST RING OF INDENTATION

This ring is included here because it is usually present dorsally and laterally in the Cyrtacanthacridinae. Its presence in other groups is open to question. It does not contain any important structures.

#### SECOND RING OF LOBES

This ring contains the *sheath*. As understood by Roberts and Dirsh, the *sheath* extends from the rami of the cingulum to the point where the ectophallic membrane of the aedeagal valves is sclerotized, or if it is not sclerotized, to the junction with the endophallic membrane. By this definition the extent of the sheath varies greatly according to whether or not the ectophallic membrane of the aedeagal valves is fused to the aedeagal sclerites. I would prefer to think of the sheath as extending from the rami only to the aedeagal valves. When the first ring of indentation is present, it serves as the dividing line. When the first ring of indentation is absent, a more or less arbitrary division must be made; the aedeagal valves are the projecting, intromittent part.

#### SECOND RING OF INDENTATION

This ring contains a well developed sclerite, the *cingulum*, which typically includes the *zygoma* and paired *apodemes* and *rami*.

The term *zygoma* has developed a double meaning. In the sense of Snodgrass (p. 64) it was "a strong transverse sclerotic bridge." Roberts and Dirsh labelled their drawings in conformity with this except for Dirsh's Plate 32, figure F, where the *zygoma* was indicated posterior to a membranous area. However, this was probably just a slip because Plate 32, figure D showed the *zygoma* anterior to this membranous area. On

the other hand, the *zygoma* has also been thought of as the general mid-dorsal region between the bases of the apodemes and rami regardless of whether it is sclerotized or not. It was this latter sense which Roberts and Dirsh were apparently using in their definitions of *zygoma* and when they stated in their definitions of *arch* that the arch connects with the *zygoma*. It is definitely this latter sense which Hubbell used when he stated (explanation of Plate XVII) that his "basal eminence" is the summit of the *zygoma*. (Hubbell stated on page 29 that his "basal eminence" has a membranous surface.) It seems wisest to return to the more precise concept of Snodgrass, who first used the term, and exclude membranous areas from the *zygoma*. However, a membranous area is sometimes so nearly enclosed by the *zygoma* and rami that it can hardly be excluded from the *cingulum*. The term *central membrane of cingulum* seems appropriate to solve this difficulty. If there should be any need to refer to the broader concept of *zygoma*, a description such as "mid-dorsal region of *cingulum*" should be sufficient.

Roberts stated (p. 245) that the ventral infold "is comparable to the invagination on the dorsum of the pallus which gives rise to the rami and *zygoma* of the *cingulum*." This is in conflict with his usage in his *Cryptosacci* where he shows it ventral to the ventral lobe and therefore part of the third ring of indentation. Roberts informs me (in conversation) that his concept of *ventral infold* agreed with his usage and not with the above quotation. In some cases there are two ventral invaginations, one in the second ring of indentation and one in the third ring. The definition of Dirsh (p. 228) is of no help as it is vague enough to include both of the ventral invaginations and the ventral lobe. The logical solution is to restrict the term *ventral infold* to the concept of Roberts in his *Cryptosacci*, *i.e.*, the invagination ventral to the ventral lobe and to whatever invagination may prove homologous to this. The invagination in the second ring of indentation may prove to be present only in occasional genera and may be referred to as a supplementary ventral infold unless future work shows it to be of wide occurrence. I am not prepared to state which invagination in Roberts' *Cryptosacci* is homologous to the "ventral infold" in his *Chasmosacci*.

## THIRD RING OF LOBES

The dorsal lobe of this ring is called the *basal fold* and is normally not sclerotized. The lobes on the sides (when present) are called the *lateral lobes* and commonly bear sclerites. When the lateral lobes are joined ventrally, they may be called the *ventral lobe*. When the second ring of indentation is sufficiently weakened, the lateral lobes or ventral lobe may fuse with the cingulum. The *ventral fold* of Dirsh is the ventral lobe as here understood. The *ventral lobe* of Dirsh is confusing. In most cases it seems synonymous with his *ventral fold*, but in the case of *Paulinia* (Pl. 29) a portion of the sheath is labelled as the ventral lobe.

## THIRD RING OF INDENTATION

The ventral invagination of this ring is the *ventral infold* and has already been discussed. The *epiphallus* and associated sclerites are found on the ventral side of the dorsal portion of this ring of indentation. For these structures the terminology of Dirsh is fully adequate and acceptable in so far as I have investigated them. An invagination is often present immediately anterior to the epiphallus and may be called the *epiphallic infold*. This term refers to the position of the invagination; the invagination does not contain the epiphallus.

## LITERATURE CITED

- DIRSH, V. M. 1956. The phallic complex in Acridoidea (Orthoptera) in relation to taxonomy, Trans. Royal Ent. Soc. London 108(7): 223-356, 66 pl.
- HUBBELL, T. H. 1960. The sibling species of the Alutacea Group of the Bird-Locust genus *Schistocerca*, Misc. Publ. Mus. Zool., Univ. Michigan No. 116: 1-91, 23 pl.
- ROBERTS, H. R. 1941. A comparative study of the subfamilies of the Acrididae (Orthoptera) primarily on the basis of their phallic structures, Proc. Acad. Nat. Sci. Phila. 93: 201-246.
- SNODGRASS, R. E. 1935. The abdominal mechanisms of a grasshopper, Smith, Misc. Coll. 94(6): 1-89.

## An Improved Technique for Using the Berlese Funnel

By M. W. McFADDEN, University of Alberta,  
Edmonton, Alberta, Canada

The Berlese funnel is probably familiar to every entomologist. It is a useful tool but unfortunately has two serious limitations: it is not portable and too much time is required (often four days) to drive all specimens from a substrate sample. However, by making use of certain chemicals and a different type of construction these limitations have been eliminated.

In the past, without portable Berlese funnels, specimens had to be either collected directly or the duration of the field trip had to be limited if habitat samples were taken. This latter choice was necessary since temperature, moisture and oxygen requirements of the insects restricted the length of time a sample could be retained before being run through the Berlese funnel.

The slowness of the Berlese funnel technique as applied in the past can be attributed to the fact that heat, light, or gravity is required to drive the insects from the sample. However, Dr. Brian Hocking of this university has recently pointed out to me, that by using a mixture of three parts naphthalene and one part paradichlorobenzene, it is possible to drive out the insects in a relatively short period of time.

The modified apparatus consists of a wooden frame with interchangeable screen filters. The lower portion of the frame is covered with plastic sheeting in the form of a cone. Two of these funnels are bolted to a stake or shaft as shown in fig. 1. The shaft is either driven or dug into the ground and the samples placed on the screen filters in the funnels. Five tablespoons of the chemical mixture are then sprinkled over each sample, the top swung into position and collecting jars set underneath the cones. All specimens are driven from the sample in approximately twelve hours, depending, of course, on the nature of the sample.

As many as five sets of these funnels can be carried in the trunk of a car so that collecting can be carried on during the



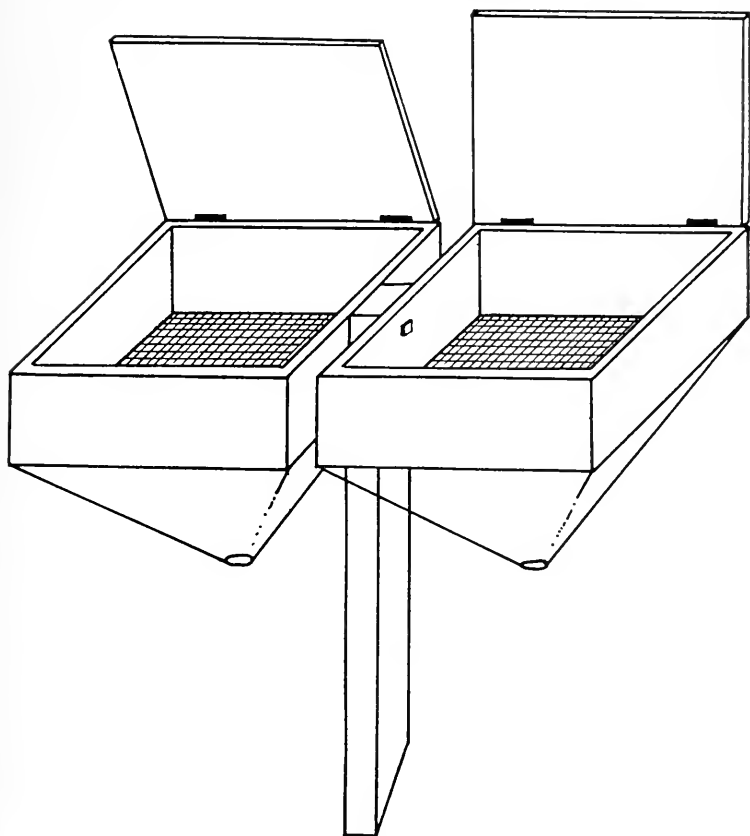

FIG. 1. The top or wood portion of the funnel is nine inches square and three inches deep; the entire apparatus is three feet high (from top of box to base of stake).

day and habitat samples brought back to the camp in plastic bags to be run through that evening. In this way specimens can be removed in the morning and the rest of the day can be used for collecting.

The above mentioned technique has been used to collect dipterous larvae, especially Stratiomyidae, but in the course of this work adults and/or larvae of Coleoptera, Odonata, Hemiptera, and Collembola also have been obtained. This tech-

nique was successful with such diverse samples as heavy muck, various manures, decaying wood, moss, forest duff, and shore debris. The fumes from the naphthalene and paradichlorobenzene seem to have little or no effect, at least upon Stratiomyid larvae, as far as rearing is concerned.

---

### An Observation of the Behavior of *Telamona compacta* Ball Preceding and During Oviposition. (Homoptera, Membracidae)

By CLIFFORD J. DENNIS, East Central State College,  
Ada, Oklahoma

These observations were made at Itasca State Park, Minnesota, on July 27, 1960, at the campground of the University of Minnesota Biological Station during work which was supported in part by a grant from the National Science Foundation.

Weather conditions during the time of observation were as follows: temperature 82 degrees, wind northwest 3-4 mph, sky clear.

A female *Telamona compacta* Ball was discovered at 1:37 p.m. CST on a bur oak, *Quercus macrocarpa* Michx., six feet above the ground, three inches from the tip of the branch. She was on the top of the branch, nearly parallel with it and facing toward its base. Her position was on the sunny, south side of the tree, but she was shaded except for the time from 2:38 until 3:35 when she was in intermittent sunlight. The abdomen of this insect was noticeably distended and somewhat pendulous posteriorly.

At 1:55 she raised the posterior part of the body about one-fourth inch and then lowered it. This action was repeated at 2:05, 2:11, 2:23, 2:42, 2:44, 2:50, and 2:57. At 2:44 she also flicked her wings slightly as a breeze shook the branch.

At 3:04 she abruptly extended her legs and elevated her entire body straight upward in a horizontal position. While in this posture she jerkily raised the knee of the left hind leg several times. The original position was resumed at 3:06.

The rear of the body was again raised and lowered at 3:10.

At 3:11 she very slowly raised her entire body to the horizontal position; this required three minutes. This posture was maintained until 3:18 when she dropped to her original position.

She raised her entire body halfway to the full height at 3:21. At 3:22 she started gradually to resume the original position and attained it at 3:24.

The posterior end of the body was again raised and lowered at 3:28.

This behavior seemed to be a kind of a warm-up for the task that lay ahead. She started to move toward the base of the branch at 3:35. Her progress was not direct. There were several stops and starts and some wandering around on the branch. By 4:35 she had progressed about two feet toward the base of the branch and had reached an area of corky protuberances at which point the branch was about one inch in diameter.

At 4:35 she was on top of this branch facing its base and made what appeared to be a tentative effort to oviposit. She unsheathed her ovipositor, raised her posterior end and positioned the ovipositor at right angles to her body. The ovipositor was then stabbed directly downward to pierce the bark tissue between corky ridges. She appeared to bounce up and down while inserting it to its full length. Withdrawal of the ovipositor occurred almost immediately; it was not sheathed completely until about thirty seconds had elapsed.

She then walked to the corky region on the top of a similar adjacent branch, taking a position facing its base. Here, at 4:45, she began striking oviposition activity. In a smoothly coordinated fashion she raised her entire body (especially the posterior end), flexed her abdomen slightly, extended the ovipositor perpendicularly to her body and quickly stabbed this structure its full length into the stem between two corky ridges. Almost immediately she withdrew the ovipositor slightly and

then fully inserted it again as she began a pumping action of the abdomen. The pumping action was continued until the ovipositor was finally withdrawn. During the time the ovipositor was inserted, the venter of the abdomen anterior to the base of the ovipositor was inclined abruptly away from the branch; the venter of the abdomen posterior to the base of the ovipositor was closely appressed to the bark. This gave the impression that she was sitting down on the bark. At 4:50 she slightly withdrew the ovipositor; at 4:51 it was again fully inserted. Similar withdrawal and insertion were repeated at 4:52 and 4:53, respectively. At 4:53:30 the ovipositor was fully withdrawn and sheathed in a smooth action which was the reverse of the insertion behavior. The insertion and withdrawal actions gave the impression of flowing, graceful motion.

The third valvulae were not inserted. These could be seen flicking as the abdomen was pumping.

The insect remained motionless eight minutes and then moved one inch to its left to the side of the branch, still facing its base, and began to oviposit at 5:04. Her behavior resembled that of the preceding instance except that she partially withdrew the ovipositor only once. This activity was completed at 5:07.

Similar behavior was observed twice more. One instance occurred from 5:21 to 5:25 on the underside of a somewhat smoother, slender part of the stem. The other took place in a corky region on the top of a slender branch, starting at 5:45. This one was not completed because I disturbed the insect while trying to obtain a closer look. My inquisitiveness caused her to fly off and become lost.

The time, place, and mechanics of the oviposition proper agree generally with those briefly reported for *Telamona* by Funkhouser (1917). However, this insect was more easily disturbed than he indicated.

#### LITERATURE CITED

- FUNKHOUSER, W. D. 1917. Mem. Cornell University Agr. Exp. Sta. 2: 177-445.

## Concerning the Neogeophilidae, with Proposal of a New Genus.<sup>1</sup> (Chilopoda: Geophilomorpha: Neogeophilidae)

By R. E. CRABILL, JR., U. S. National Museum, Smithsonian Institution, Washington, D. C.

In 1918 Filippo Silvestri proposed as new two remarkable genera, *Neogeophilus* and *Evallogophilus*, and assigned them to a new geophilid subfamily, Neogeophilinae. He observed that the Neogeophilinae were to be distinguished from all other geophilids by their second maxillary coxosterna which are completely divided midlongitudinally, each bearing anteriorly a pair of peculiar uniarticular, lobate structures in place of the usual telopodites, associated medial projections, and lappets. The distinctiveness of his new forms, he explained, was further enhanced by their bizarre pretarsal modifications: each of the more anterior pretarsi bears a sizeable tooth projecting from the ventral arch of the pretarsal claw proper. Each of these three characteristics was unknown to occur within the Geophilidae, and their combination was, and remains, common only to the Neogeophilidae.

In 1926 Attems elevated the Silvestri subfamily to full family rank but cautioned that family status must remain provisional prior to a more detailed presentation of distinctive features. In his ordinal monograph of 1929 Attems summarized what was known of the neogeophilids—somewhat inaccurately, as we shall see—but continued to accord to them full family status. Since 1929 no new species have been referred to the family, and no new evaluation of the Silvestri specimens has been issued. The matter rests as Dr. Attems left it: the rank of the suprageneric, collective category to which the Silvestri genera and the present new genus are referable remains provisional.

*Neogeophilus* and *Evallogophilus* were founded upon two species, which in turn were based upon three specimens. To these may now be added a fourth specimen, representing a new

<sup>1</sup> This study was undertaken with the aid of a grant from the National Science Foundation (G9805).

species and, evidently, genus. This newest neogeophilid was discovered among some undetermined, miscellaneous material that was collected more than fifty years ago in Guatemala and sent to O. F. Cook, whose interests by that time had shifted nearly completely from Chilopoda to Diplopoda and botany. Dr. Cook labelled the specimen as a "*Geophilus*," then put it aside, apparently without further attention. This specimen manifests the same distinctive higher categorical characteristics that Silvestri recognized in his two species. In addition to these diagnostic family characters that Silvestri specified, there is another of considerable significance that he failed to cite. The basal article of the second maxillary telopodite is entirely without dorsal and ventral condyles. They are absent in the present, new form, and, according to his figures, they are absent in his two species.

#### CRYPTOSTRIGLA, new genus

Differential Diagnosis.—The new genus, while sharing some significant characters with each of the other genera, seems more reminiscent of *Evallogeophilus* than of *Neogeophilus*. At the same time it manifests certain features seen in neither of the Silvestri genera. The presence in *Cryptostrigla* of the following features will readily distinguish it from *Neogeophilus*: ultimate pedal pretergite and pregenital sternite are indistinctly separated from their respective, adjacent plates; the subcondylic sclerotic lines of the prosternum are abortive and incomplete, hence do not pass across the prosternal corner to or toward the telopodite condyles; the female gonopod consists of one article, the two constituent articles having fused without discernible trace of an intervening suture.

The following generic characters are common both to *Evallogeophilus* and *Cryptostrigla*: prosternal denticles are present; the ultimate pedal pretergite is completely or almost completely amalgamated with its tergite; the ultimate pedal sternite is completely or almost completely amalgamated with the pregenital sternite; the paraclypeal sutures do not diverge outward posteriorly (see discussion under Notes). These two genera differ, at least, as follows. *Evallogeophilus*: (1) prosternal subcon-

dylic sclerotic lines pass toward and meet or nearly meet the basal prehensorial condyles; (2) each female gonopod is distinctly biarticulate, the interarticular suture being persistent; (3) ultimate pedal pretergite is apparently wholly fused with its tergite (see Silvestri's Figs. 6, 9, p. 357: see discussion under Notes below); (4) ultimate pedal sternite apparently wholly fused with the pregenital sternite (see Silvestri's Figs. 7, 10, p. 357). *Cryptostrigla*: (1) prosternal subcondylic sclerotic lines are abortive and coincident with part of the pleuroprosternal sutures, the former neither meeting nor passing toward the prehensorial condyles; (2) each female gonopod manifests no discernible interarticular suture, the two constituent articles having fused without trace of division; (3) the ultimate pedal pretergite is intimately fused with its tergite, but the intervening transverse suture, although obscure and vestigial, is persistent and readily discernible under optimum conditions of observation; (4) the ultimate pedal sternite is intimately fused with the adjacent pregenital sternite, but the intervening suture, although extremely obscure and vestigial, is still discernible but with difficulty.

See also the family résumé at the end of the article, where the generic diagnostic features are presented comparatively in tabular outline.

Type-species: *Cryptostrigla silvestri*, new species. (Present designation and monotypic).

Notes.—In his original description of *Evallogophilus*, Silvestri characterized its ultimate pedal dorsal sclerite as follows, relying heavily upon this particular generic criterion for distinguishing between it and *Neogophilus* (p. 357): "Genus hoc a genere *Neogophilus* tergito segmenti ultimi pediferi praetergito destituto, . . ." He reported that the pretergite was absent, as indeed his figures 6 and 9 show it to be. Yet, comparing these figures with their counterparts for *N. primus* (p. 353, Fig. 13), the reader will see that the ultimate pedal tergite of *mexicanus*, which appears abnormally long, actually represents that tergite plus its associated pretergite. In other words, in *mexicanus* the pretergite and tergite are entirely amalgamated

without discernible intervening suture, or, if there is a suture, it is so vague that it escaped Silvestri's notice. Clearly, this degree of amalgamation does not typify *primus*, whose intertergital suture he recognized and figured in Fig. 13.

In *Cryptostrigla silvestri* the pretergite and tergite are intimately fused, but the intervening transverse suture is both persistent and, though obscure, easily visible after mounting in Hoyer's fluid and under optimum conditions of observation.

A similar explanation is almost certainly pertinent to the absence of certain ventral ultimate plates and sutures in *mexicanus*. On page 356 Silvestri wrote: ". . . sterno subaeque longo atque ad basim lato, lateribus paullum convergentibus, postice aliquantum sinuato, *tergito praetergito nullo*, . . ." If the reader will compare Fig. 16 on p. 353 (of *primus*) with its counterpart, Fig. 10, p. 357 (of *mexicanus*), he cannot but be struck by the facts, first, that the ultimate pedal sternite of *primus* is notably shorter and wider than that of *mexicanus*; secondly, that the pregenital sternite of *primus* (Fig. 16) is entirely absent in *mexicanus* (Fig. 10). Without much doubt, what Silvestri took to be the ultimate pedal sternite of *mexicanus* was, in fact, that sternite plus the following pregenital sternite with which it is intimately fused. The same is true in the case of the female (Fig. 7, p. 357), whose pregenital sternite is apparently absent and whose ultimate pedal sternite is abnormally long. In summary, one of two explanations must be true in the case of *mexicanus*, either: (1) the two plates are completely amalgamated without trace of an intervening suture, or; (2) the two plates are intimately fused but still separated by an intervening, vestigial suture that escaped Silvestri's notice. As has already been noted, in *C. silvestri* there is intimate fusion of the dorsal and of the ventral plates, but in each case there is a visible, vestigial suture testifying to what has happened.

Silvestri's original figures necessitate raising two additional queries. In each of these two instances we are confronted with the same question: Does the figure of the character appear extraordinary because it actually is, or rather because it was misrepresented by the artist?

In two figures (Fig. 13, p. 353, Fig. 13, p. 355) Silvestri has



shown the anterior surfaces of two representative pretarsi that are typical of his two new species. In each figure the anterior accessory spine is depicted as being very long, rather sinuous, apically abruptly pointed, or even notched apico-ventrally, and apparently hyaline or semi-translucent. In short, as he has figured them, these spines seem somewhat like long, fleshy lap-pets. One cannot help but wonder whether the anterior accessory spines have been misrepresented. In *Cryptostrigla silvestri* this accessory spine on all legs is perfectly straight and never sinuous; it is never notched apically or abruptly attenuate, and, what is most important, it is typically spinelike and quite opaque.

Secondly, note that in *primus* (Fig. 2, p. 353) the artis has shown the paraclypeal sutures to diverge outward posteriorly far beyond the rear clypeal margin. If this representation is accurate, then we are confronted with a remarkable departure from the usual case, wherein the two paraclypeal sutures, when complete, terminate at or near the posterolateral clypeal corner. If these sutures are as Silvestri has shown them, then they must be accorded preeminent significance as a generic criterion.

Finally, mention should be made of several important errors which Attems seems to have injected into his summary of the family (1929, p. 346). In his family diagnosis Attems reported that the ultimate pretarsus consists of one article. Insofar as the reader might therefore attribute this condition to all neogeophilids, his statement is misleading. In all known neogeophilids this character seems to be subject to intersexual dimorphism: the ultimate tarsus is uniaarticulate in the known males of *N. primus* (Fig. 16, p. 353) and *E. mexicanus* (Fig. 10, p. 357), but it is biarticulate in the known females of *E. mexicanus* (Fig. 6, p. 357) and of *C. silvestri*.

Attems also characterized *E. mexicanus* (key, p. 346) as lacking a pretergite, whereas, as I have suggested above, it has a pretergite which is either wholly fused with the tergite, or else incompletely fused with it, in which latter case Silvestri's original description is in error.

(To be continued)

## New North American Tabanidae XIII. Change of Name for a Well-Known Species of *Chrysops*<sup>1</sup>

By CORNELIUS B. PHILIP<sup>2</sup>

Since the time of Osten Sacken (1875), *Chrysops univittatus* Macquart is a name assigned to a species common east of the Mississippi River and extending west to Kansas and Nebraska and north to Quebec. He states: "The identity of this species with Macquart's *C. univittatus* can hardly be called in doubt." Subsequent workers, including the writer, have followed him in this assignment. Osten Sacken also questioned the possible synonymy of *C. fascipennis* Macquart from Philadelphia, but further states: ". . . the shortness of the description renders the identification impossible."

Macquart (1855) gives the locality of *C. univittatus* as Baltimore but he did not indicate whether he had more than one specimen. A type, previously overlooked in the British Museum (Natural History) on visits by Hine, Kröber, and the author, labelled "Baltimore" and "univittatus n.sp." in Macquart's handwriting, was discovered by me on a visit in 1960. No other types were found in Macquart cabinets at the Paris and Lille Museums and it may be presumed the BMNH specimen is a holotype. No type for *C. fascipennis* has been located in any of these collections so that the relationship suggested by Osten Sacken has not been possible to verify or negate.

The *univittatus* type now lacks abdomen and antennal flagellums, but characters of the wing picture, face widely black on both sides of lateral sutures, dark scutellum, basal one-third of mid-femora and one-half of hind pair darkened, agree closely with a compared female from New York of *C. wiedemanni* Kröber. The abdominal pattern and legs, as originally de-

<sup>1</sup> These studies were supported by a travel grant from the March Fund of the National Academy of Sciences.

<sup>2</sup> U. S. Department of Health, Education, and Welfare, Public Health Service, National Institutes of Health, National Institute of Allergy and Infectious Diseases, Rocky Mountain Laboratory, Hamilton, Montana.

scribed, also agree best with *C. wiedemanni*. This unfortunate misidentification and preoccupation change the concepts of two important and common species of Nearctic *Chrysops*. There is not time, before appearance of a Nearctic catalog of Diptera, to request plenary action of the International Commission to conserve present assignments of *C. univittatus* and *C. wiedemanni*. Recourse to substitution of *C. fascipennis* for *C. univittatus* of authors, not Macquart, is not justified on present information.

Under these circumstances, *C. wiedemanni* Kröber becomes a synonym of *C. univittatus* Macquart, not of authors. For *C. univittatus* of authors, not Macquart, the new name *C. macquarti* n.sp. is proposed.

Holotype ♀, 7.0 mm. Differs from the adequate description of *C. univittatus* given by Osten Sacken (1875) in the following minor respects: Face largely yellowish, the apodemal pits and sutures narrowly brown; callosity brown; scutellum largely yellow with a small mid-basal spot. These characters are within the usually observed variation. Fig. 56 of Brennan (1935) is a good depiction of the wing pattern of this type.

Catonsville, Baltimore, Md., June 30, 1922. F. M. Root. In the collection of the author.

Allotype ♂, 6 mm. Resembles the female except the black on the parafacials larger, and infuscation of second basal cell about two thirds its length.

Riverdale, Maryland, 6-9-11. No collector. In collection of the author.

Paratype males. *New York*: 2 (reared), Oswego, June, Logothetis; 1, Ithaca, July, Evans. *Pennsylvania*: 1, Swarthmore, July, Cresson, Jr. *Wash., D. C.*: Rock Creek Park, July, Arnaud, Jr.

Paratype females. *Maryland*: 1, Hillsdale, Baltimore, July 5, 1922, F. M. Root (nearly topotypic). *Massachusetts*: 2, Leverett and Amherst, July, Coher. *New York*: 3, Wading River and Tuxedo, July and August, no collector; 6, Genesee Co., July and August, Pechuman. *New Jersey*: 4, Atsion, Francis Mills and Burlington Co., June and July, Hansens, Belkin, and Conant and Thomas. *Pennsylvania*: 4, Green Valley and Clarke Valley, June and July, Kirk and Champlain. *Virginia*: 1, Giles

Co., August, Nuttycombe. *North Carolina*: 1, Highlands, July, Byers. *Georgia*: 13, Athens, Stone Mt., Grassy Mt., Murray Co., Attapulgis, Rabun Co., and Yonah Mt., May, June and July, Loizeaux, Fattig and Sudia. *Ohio*: 11, Lancaster, Bainbridge, Vinton Co., Athens Co., Summit Co., Lucas Co., and Amherst, June and July, Goshin, Orago, Thomas and Thomas, Stehr, Campbell and Campbell, Lipovsky. *Indiana*: 2, Cass Co., June, Williamson. *Michigan*: 2, Gull Lake Biol. Sta., Kalamazoo, July, Fischer. *Florida*: Alachua Co., April and May, Dean and Stephens. *Ontario*: Puslinch, June, Pechuman.

In the U. S. National Museum, British Museum (Natural History), and collections of L. L. Pechuman and the author.

Variation occurs in which the abdominal pattern fades to obscure brown shadows in a few specimens from New Jersey, Ohio and Georgia, but these are recognizable by the wing patterns and entirely yellow femora. Varietal names do not appear to be warranted analogous to those in the *flavida* complex.

The type localities of both *C. univittata* and *C. macquarti* thus are Baltimore and indeed they fly together over a considerable proportion of their respective ranges, but are quickly separated by several characters including the more extensive apical spots and infuscated first basal cells in the latter.

Though Stone (1930) has described the immature stages of *C. wiedemanni* (= true *univittatus*), those of *C. macquarti* appear not to have been reported.

#### REFERENCES

- BRENNAN, J. M. 1935. Bull. Univ. Kans. 36: 249-401.  
MACQUART, P. J. M. 1855. 5° Suppl. Soc. des Sci. Lille, Mém., 1854: 25-156.  
OSTEN SACKEN, C. R. 1875. Mem. Bost. Soc. Nat. Hist. 2: 365-397.  
STONE, ALAN. 1930. Ann. Ent. Soc. Amer. 23: 261-304.

## A New Rhinotragine Cerambycid from Arizona and Sonora (Coleoptera)

By E. GORTON LINSLEY, University of California, Berkeley

The Rhinotraginae comprise a group of Neotropical Cerambycidae of which more than 200 species have been described. They are of special interest to students of natural selection because of the remarkable mimetic form, coloration, and behavior exhibited by species in the various genera. These suggest an unusually wide range of models, including bees, wasps, and beetles of several families. Perhaps no comparable group of animals has developed diversified mimicry to such a degree.

Until now, no species of Rhinotragini has been known to occur within the boundaries of the United States. The species here recorded belongs to the genus *Odontocera*, as currently defined, and appears to be *O. aurocincta* Bates. However, the population occurring in Southern Arizona and Sonora appears to be sub-specifically different from those in Yucatan and Vera Cruz.

### *Odontocera aurocincta arizonensis* Linsley, new subspecies

Male: Integument piceous black, mouthparts somewhat rufo-testaceous, anterior tibiae, especially beneath, and intermediate and posterior tibiae at base and apex and most of antennal flagellum rufo-testaceous, first two abdominal segments testaceous, elytra with base and humeral region black, basal one-third of lateral margin black, becoming rufo-testaceous except as it approaches base, disk transparent, whitish, becoming yellowish or rufo-testaceous at apex; pubescent patches silvery white, including margins of pronotum, scutellum, median area of prosternum, and margins of meso- and metasterna. Length 17 mm.

*Holotype* male (Calif. Acad. Sci.), from Box Canyon, Santa Rita Mountains, ARIZONA, August 1, 1959, at flowers of a mimosaceous shrub (*D. S. Verity*). *Paratypes*, a male from Sabino Canyon, Santa Catalina Mountains, Arizona, September 5, 1957 (*R. L. Westcott*), a male from Mocuzari, Sonora, Sep-

tember 25 (R. L. Westcott), and a male from Santa Ana, Sonora, July 22, 1940 (R. P. Allen).

What I assume to be females of this subspecies were taken in the vicinity of Alamos, Sonora, by R. L. Westcott as follows: two examples, Alamos, Sonora, July 30–August 9, 1957, one example 8 miles west of Alamos, August 9, 1957, and one example 18 miles west of Alamos, July 30, 1957. In addition to the usual sexual differences in the structure of the abdomen, development of the eyes, etc., these differ from the male by having the head, pronotum, and sides of mesosternum red, the basal antennal segments yellowish rather than black, the legs yellow with the claviform portion of the intermediate and posterior femora piceous brown, that of the anterior femora clouded with piceous, the first two abdominal segments piceous brown basally, last three segments brown, the elytra without a black basal and humeral area and the pubescent patches of the pronotal and meso- and metasternal margins golden instead of white. In this last respect they resemble the female of typical *O. aurocincta* Bates (1873) from Yucatan more closely than that of the "variety" *nigroapicalis* Fisher (1947) from Vera Cruz. From both, however, they differ in the red head and pronotum.

The species of *Odontocera* exhibit great diversity of form, some species resembling meliponid bees, others vespid wasps. This resemblance carries over to the flight habits of the beetles (Bates, 1873), and Wheeler and Darlington (1930) have not only recorded vespid-like flight for *O. triplaris* Fisher,<sup>1</sup> but the occurrence of a similarly colored vespid<sup>2</sup> with them. The present species is much more wasp-like than bee-like. If both sexes are mimetic they presumably have quite different models, in view of the dichromatism which they exhibit.

<sup>1</sup>The species of *Odontocera* referred to by Wheeler and Darlington were subsequently described by Fisher as follows: no. 7 (p. 110) as *O. triplaris* and no. 9 (p. 111) as *O. darlingtoni*.

<sup>2</sup>The vespid has been tentatively identified as *Polybia emaciata* Luc., a species widely distributed in Tropical America. It shares similar coloration not only with vespids of similar genera, but also, as pointed out to me by H. E. Evans, with a trigonalid and a pompilid.

## LITERATURE CITED

- BATES, H. W. 1873. Notes on the Longicorn Coleoptera of Tropical America. *Ann. Mag. Nat. Hist.* (4)11: 21-45, 117-132.
- FISHER, W. S. 1947. New cerambycid beetles belonging to the tribe Rhinotragini. *Proc. U. S. Nat. Mus.* 97: 47-57.
- WHEELER, W. M. and P. J. DARLINGTON, JR. 1930. Ant-tree notes from Rio Frio, Colombia. *Psyche* 37: 107-117.

---

## **Herpetomonas muscarum (Leidy) in the Haemocoel of Larval *Musca domestica* L.<sup>1</sup>**

By JOHN PAUL KRAMER, Illinois Natural History Survey,  
Urbana, Illinois

In late September, 1959, the author collected 61 sluggish and immobile larvae of *Musca domestica* L. from mounds of insecticide-free chicken feces at a farm near Tolono, Illinois. These larvae, which were well-developed third instars, were brought back to the laboratory for study. Fifty-seven of them responded vigorously to light raps with a blunt probe, and, in addition, exhibited pulsation of the dorsal vessel. A single larva did not respond to the aforementioned tactile stimulus although a faint pulsation of the dorsal vessel was visible. The three remaining larvae were considered dead since they neither responded to the probe nor was pulsation of the dorsal vessel observable. As a matter of routine each whole larva was examined microscopically in order to detect gross changes, if any, in its organs.

No abnormalities were noticed among the 57 active larvae. On the other hand, the haemolymph of the single moribund larva and of the three dead larvae was teeming with the long slender protozoan, *Herpetomonas muscarum* (Leidy) (Flagellata: Trypanosomatidae). The microparasites could be observed through the integument of the larvae without dissection. No evidence of decay or mechanical injury was present in these four larvae.

<sup>1</sup> This investigation was supported in part by Research Grant E-1231 from the National Institute of Allergy and Infectious Diseases of the National Institutes of Health, Public Health Service.

Thus it is evident that *M. muscarum* does gain entry to the haemocoel of the host in some instances. Further it seems possible that *H. muscarum* may be a facultative pathogen under these circumstances. This is noteworthy since *H. muscarum* is generally considered a benign parasite which is restricted to the alimentary tract of adult muscoid flies in nature (Steinhaus 1949, and West 1951).

#### REFERENCES

- STEINHAUS, E. A. 1949. Entomogenous Trypanosomidae, p. 116-117. In E. A. Steinhaus, Principles of insect pathology, McGraw-Hill Book Co., New York.
- WEST, L. S. 1951. Protozoa, p. 240-243. In L. S. West, The housefly, Comstock Publ. Co., Ithaca.

---

### Symposium

A **Symposium on Insect Metamorphosis** has been announced by the Royal Entomological Society of London, at the Society's Rooms, 41 Queen's Gate, London, S.W.7, on September 21st and 22nd, 1961, to bring together leading representatives of different approaches to polymorphism and to put the subject into better perspective to entomologists in general.

The participants from Britain include J. S. Kennedy, A. D. Lees, and V. B. Wigglesworth (all of Cambridge), E. B. Ford (Oxford), O. W. Richards (London), P. M. Sheppard (Liverpool), J. H. Sang (Edinburgh), M. Lüscher (Bern), Th. Dobzhansky (Columbia Univ.), and C. D. Michener (Kansas).

The meeting is open, by ticket, to all scientists who have registered (£1) by May 5th. The Symposium volume will be available later, priced at £1 0s. 0d.



## New Subscription Rates for 1962

The cost of printing and distributing ENTOMOLOGICAL NEWS has been increasing greatly in recent years. The present low rates have been possible only as a result of the steady growth of our subscription list together with the fact that all editorial work is volunteer; also there has been income from the sale of back volumes, and advertising support from the Society. Now, however, recent sharp increases in costs make it necessary to secure additional income from subscriptions.

Beginning January, 1962 (Vol. 73), the subscription rate to libraries, laboratories, and institutions of every sort, both domestic and foreign, will be \$9.00, postpaid, per annual volume of 10 issues.

Subscriptions for personal, individual use will also be increased somewhat to \$6.00, postpaid, domestic and foreign.

To members of the American Entomological Society the rate is \$3.00.

This modest advance in rate for personal subscriptions is the first since 1952, and, it is felt, will occasion no decrease in the number of such subscriptions from the many amateur and professional entomologists who now read the NEWS; in fact it is hoped that many younger enthusiasts, especially students, will be encouraged to subscribe. By thus maintaining a large circulation, even if in part at a reduced rate, the costs will be more broadly spread to the ultimate benefit of institutional as well as individual subscribers.

As an additional economy, the NEWS will discontinue the offer of free separates of their articles to members of the Society.

# Entomologist's Market Place

## ADVERTISEMENTS AND EXCHANGES

Advertisements of goods or services for sale are accepted at \$1.00 per line, payable in advance to the editor.

Notices of wants and exchanges not exceeding three lines are free to subscribers.

All insertions are continued from month to month, the new ones are added at the end of the column, and, when necessary, the older ones at the top are discontinued.

---

**Butterflies.** Wish to exchange specimens for Japanese species. Please write to Ichiro Nakamura (Boy, age 16), 26 Aza-Nichiyama Obayashi Takarazuka-shi, Hyogo-Ken, Japan.

**Phasmidae** of nearctic area desired alive. Purchase or trade, drawing on large stock of major orders, worldwide. Domminck J. Pirone, Dept. Entomology, Cornell University, Ithaca, N. Y.

**Nitidulidae** and **Rhizophagidae** wanted in exchange for European beetles of all families. O. Marek, Zámberk 797, Czechoslovakia.

**Wanted and Needed.** We are compiling a history of entomology, and particularly, at present, of the amateur insect clubs that flourished 50 to 75 years ago. Will you who have knowledge of such early clubs or societies advise me, giving facts on the time of existence, members, etc., which you may have. J. J. Davis, Dept. of Entomology, Purdue University, Lafayette, Indiana.

**Cockroaches (Blattoidea)** of Japan, Okinawa, Formosa (Taiwan), and the Philippines are being studied in cooperation with Dr. K. Princis. Loans of specimens from that area are desired. A. B. Gurney, U. S. National Museum, Washington 25, D. C.

**Orthoptera.** **Gryllinae** (except domestic sp.) and **Pyrgomorphinae** of the world wanted in any quantity for work in morphology, taxonomy, cytology, and experimental biology; dry, or in fluid, or living. Write D. K. Kevan and R. S. Bigelow, Dept. of Entomology, McGill University, Macdonald College, Quebec, Canada.

**Beetles** of the world wanted, all species in exchange for American beetles, moths and butterflies. James K. Lawton (age 18), 7118 Grand Parkway, Wauwatosa 13, Wisconsin.

**Used genuine Schmidt boxes**, excellent condition, at less than half price. H. W. Allen, Box 150, Moorestown, N. J.

# Important Mosquito Works

**MOSQUITO ATLAS. Part I.** The Nearctic Anopheles, important malarial vectors of the Americas, and *Aedes aegypti* and *Culex quinquefasciata*

**MOSQUITO ATLAS. Part II.** The more important malaria vectors of the Old World: Europe, Asia, Africa and South Pacific region

By Edward S. Ross and H. Radclyffe Roberts

Price, 60 cents each (U. S. Currency) with order, postpaid within the United States; 65 cents, foreign.

---

## KEYS TO THE ANOPHELINE MOSQUITOES OF THE WORLD

With notes on their Identification, Distribution, Biology and Relation to Malaria. By Paul F. Russell, Lloyd E. Rozeboom and Alan Stone

Mailed on receipt of price, \$2.00 U. S. Currency. Foreign Delivery \$2.10.

---

For sale by the American Entomological Society, 1900 Race Street, Philadelphia 3, Pa., U. S. A.

---

## Just Published

### New Classified Price Lists

Available separates from the TRANSACTIONS OF THE AMERICAN ENTOMOLOGICAL SOCIETY and ENTOMOLOGICAL NEWS, and all titles of the Society's MEMOIRS have been catalogued by author in twelve special price lists in the following categories:

Coleoptera  
Diptera  
Hemiptera  
Hymenoptera  
Lepidoptera  
Memoirs

Neuroptera and Smaller Orders  
Odonata  
Orthoptera-Dermoptera  
Arachnida and Other Classes  
Bibliography-Biography  
General

Lists will be mailed free upon request. Please state specifically which list or lists you require.

**The American Entomological Society**

1900 RACE STREET

PHILADELPHIA 3, PENNSYLVANIA

Just Published

**MEMOIRS OF THE AMERICAN  
ENTOMOLOGICAL SOCIETY**

Number 17

**A TAXONOMIC STUDY OF THE  
MILLIPED FAMILY SPIROBOLIDAE  
(DIPLOPODA: SPIROBOLIDA)**

By William T. Keeton

147 pages of text, 37 tables, 2 maps, 18 plates,  
table of contents and index

Spirobolid millipeds are probably the most widely known Diplopoda in the United States, being used in many college courses; yet the family has been little studied. This monograph brings together existing knowledge of the group for the first time, and adds much new information gained from critical study of series. The taxonomic history of the family is outlined. External morphology is briefly treated, with emphasis on characters utilized in classification. A summary of current knowledge of life histories is included. The family is redefined, and each genus and species is treated in detail. Particular attention is given to variation and distribution, both of which become more meaningful biologically as a result of synonymizing many species names. Possible phylogenetic relationships of the genera are discussed, and keys to all taxa are provided, with most diagnostic characters illustrated in 18 plates or summarized in 37 tables.

Price \$5.50

---

**THE AMERICAN ENTOMOLOGICAL  
SOCIETY**

1900 Race Street, Philadelphia 3, Penna., U.S.A.

ects.

# ENTOMOLOGICAL NEWS

**JULY 1961**

Vol. LXXII

No. 7

---

**CONTENTS**

Gillaspy—A new <i>Stictiella</i> from Mexico .....	169
McDermott—A new genus of firefly .....	174
Crabill—Concerning <i>Neogeophilidae</i> (cont.) .....	177
Selander—Meloid beetles from the West Indies .....	190
Judd— <i>Melanagromyza</i> from linden galls .....	192
Throne— <i>Psectra</i> diptera in Wisconsin .....	193
Review—A manual of common beetles .....	194
Rapp— <i>Corrodentia</i> in cliff swallow nests .....	195

---

PUBLISHED MONTHLY, EXCEPT AUGUST AND SEPTEMBER, BY  
THE AMERICAN ENTOMOLOGICAL SOCIETY  
PRINCE AND LEMON STS., LANCASTER, PA.  
AND  
1900 RACE STREET, PHILADELPHIA 3, PA.

---

Subscription, per yearly volume of ten numbers: \$5.00 domestic; \$5.30 foreign; \$5.15 Canada.  
Second-class postage paid at Lancaster, Pa.

NEW YORK  
JULY 1961

# ENTOMOLOGICAL NEWS

---

**ENTOMOLOGICAL NEWS** is published monthly, excepting August and September, by The American Entomological Society at Prince and Lemon Sts., Lancaster, Pa., and the Academy of Natural Sciences, 1900 Race Street, Philadelphia 3, Pa., U. S. A.

**PHILIP P. CALVERT**, Editor Emeritus. **R. G. SCHMIEDER**, Editor. Editorial Staff: **H. J. GRANT, JR.**, **E. J. F. MARX**, **M. E. PHILLIPS**, and **J. A. G. REHN**.

**SUBSCRIPTIONS:** Communications and remittances to be addressed to **Entomological News, 1900 Race Street, Philadelphia 3, Pa.**

Prices per yearly volume of 10 numbers.

Private subscriptions, for personal use: in the United States, \$5.00; Canada, \$5.15; other countries, \$5.30.

Institutional subscriptions, for libraries, laboratories, etc.: in the United States, \$6.00; Canada, \$6.15; other countries, \$6.30.

**ADVERTISEMENTS:** Rate schedules available from the editor.

**MANUSCRIPTS** and all communications concerning same should be addressed to **R. G. Schmieder, Zoological Laboratory, University of Pennsylvania, Philadelphia 4, Pa.**

The receipt of all papers will be acknowledged and, if accepted, they will be published as soon as possible. Articles longer than eight printed pages may be published in two or more installments, unless the author is willing to pay the cost of a sufficient number of additional pages in any one issue to enable such an article to appear without division.

**ILLUSTRATIONS:** Authors will be charged as follows: For text-figures, the cost of engraving; for insert plates (on glossy stock), the cost of engraving plus printing. Size limit, when printed, 4 × 6 inches. All blocks will be sent to authors after printing.

**TABLES:** The cost of setting tables will be charged to authors.

**SEPARATA:** Members of the American Entomological Society may elect to receive, gratis, 25 offprints of their contributions. These will be "run-off-form," without removal of extraneous matter.

Those members desiring more than 25 separates, and all non-members, will receive no gratis copies. They must obtain all their separates (as reprints, with extraneous matter removed) from the printer at the prices quoted below. Authors must place their order for such separates with the editor at the time of submitting manuscripts, or when returning proof.

Copies	1-4 pp.	5-8 pp.	9-12 pp.	Covers
50	\$4.35	\$6.96	\$10.88	\$4.74
100	5.21	8.26	13.05	6.48
Add'l 100	1.74	2.60	4.33	3.48

Plates printed one side: First 50, \$3.47; Additional 100's, \$2.61.

Transportation charges will be extra.

# ENTOMOLOGICAL NEWS

VOL. LXXII

JULY, 1961

No. 7

## A New Species of *Stictiella* from Mexico (Sphecidae: Bembicini)

JAMES E. GILLASPY, Sul Ross State College, Alpine, Texas

This description is presented to make the name available for publication of behavioral data by the collector, Dr. Howard E. Evans, for whom the species is named.

*Stictiella evansi*, n. sp.

*Holotype Female*.—Length 15 mm. Color pattern triphasal black, yellow, and clear (or hyaline), the latter limited principally to margins of metasomal sclerites. Black areas represent melanic infusion of the integument, which is otherwise clear. Yellow is developed beneath and is seen through the transparent integument. Yellow areas are as follows: pedicel and scape below; clypeus except pair of "nasal" spots; intersocketal area, not attenuated above or enclosing sockets; broad anterior orbits narrowing abruptly above; complete V above frontal pit receiving anterior ocellus; posterior orbits exceeding inner angles of compound eyes, continuous across vertex except for narrow median and lateral interruptions, not attaining the occipital suture posteriorly, and no yellow being found posterior to the occipital suture; pronotum except transverse band extending to base of each lateral lobe; mesonotum in form of nested U's, outer U based on scutellum, extending anteriorly almost to anterior margin of scutum and bordering scutum except anterior to tegulae, inner U lyre-shaped, interrupted medially; tegulae anteriorly; postscutellum except narrow anterior crescent; propodeal triangle except basal crescent and apex; postero-

lateral angles and anterior border of propodeum including spiracles; mesepisterna and metepisterna broadly above, except black along sulci; discal spot of hypopleural areas; coxae and trochanters apically to some extent; femora except above; tibiae except spot below on middle tibiae and except hind tibiae above; anterior tarsi; middle tarsi except distitarsi above; hind tarsi except nebulous areas above; first tergite except anterior face, invading subsutural areas basally and extending posteriorly as a broad median tongue, triradiate, narrowly connected to apical black at midline, leaving elliptic-ovate postgradular spots joined to lateral maculation; remaining tergites with elements of this pattern, but antero-median black tongue broadening on tergites 2-4 (proportionately broader on 5-6) and not connected to apical black except on tergite 5; tergite 6 without apical black; sternite 1 medially and apically; sternites 2-6 with progressively smaller lateral spots, separated by progressively broader, apically narrowing, medial black.

Vestiture inconspicuous, not concealing integumental surface, that of clypeus and anterior orbits fine, appressed, giving silvery sheen.

Head wider than thorax at posterior lobes of pronotum (1.06:1). Scape moderately stout, length about three times greatest width. Maxillae apical of palpal base in length more than half of head width (1:1.77); maxillary palpi with six segments, labial palpi with four. Labrum longer than basal width (1.2:1). Clypeus width less than half of head width (1:2.27), narrower than distance between compound eyes at vertex (1:1.04), distinctly less than interocular distance at vertex (1:1.10); surface of clypeus slightly protuberant in lateral view, exceeding intersocketal carina; basal part of clypeus without a distinctly planate area; epistomal suture at closest point distant from antennal sockets by about one-fifth intersocketal distance (1:4.8), this at subantennal angles, between which it is slightly bowed downward; outwardly from subantennal angles sloping distinctly to tentorial angles, thence almost rectilinearly to compound eyes, where it is angulated and again almost rectilinear to lateral angles. Intersocketal carina obsolete above clypeus,



highest at midpoint of sockets, not exceeding sockets above except as weakly raised frontal line to frontal fovea, above which it is weakly impressed to anterior ocellar basin. Anterior ocellar mound circular in form, both a crest and peripherally, shallowly interrupted on midline below, deeply interrupted to lens level on midline above. Anterior ocellus a glabrous, light-pervious surface occupying the floor of the basin formed by the anterior ocellar mounds, surface delimited above by an arch-shaped sulcus, thence sloping, crescentwise, to deepest point immediately outside (below) arms of arch; arch slightly wider than long (1.14:1).

Mesosoma with punctuation of mesoscutum and scutellum uniformly fine and dense. Propodeal triangle formed of rectilinear sutures, converging on posterior face of propodeum at about a  $90^\circ$  angle. Legs of medium build; distitarsi with scattered bristles ventrally; arolium and other median pretarsal structures not at all bulbous but padlike and scarcely evident, the claws capable of close apposition; claws all similar, uniform in curvature, outer claw of each pair very little longer. Wings beyond humeral plate two and one-half times thorax width, measured at posterior lobes (2.51:1); second cubital cell slightly narrowed above, slightly wider than high.

Metasoma with tergite 2 having smallest lateral punctures, exclusive of those in unpigmented marginal area, similar to subsutural punctuation of tergite 1, tergites 3-6 with punctures progressively coarser and more sparse.

*Allotype Male*.—Length 16 mm. General appearance and pattern of markings fairly similar to female except more slender and maculation less extensive.

Antennae with tyloides evident on segments 4-13 (apical only on 4) as longitudinal, broadly raised or subcarinate glabrous areas; segments 2-12 distinctly excised distally on side inward to curvature of antennae; penultimate segment without inner apical process.

Legs slender; distitarsi slender, widening apically, length more than three times greatest width, all approximately similar in form and size; anterior femora slender, only moderately thin

dorso-ventrally; anterior tarsal segments 2-4 not distinctly lobed or flattened; middle femora slender, anterior and posterior surfaces longitudinally rectilinear, parallel, posterior surface carinate-serrate, teeth relatively weak, unevenly spaced, increasing in size apically, from posterior aspect the carina and serrations rectilinear and uniformly medial with respect to dorsal and ventral surfaces except two apical teeth widely spaced, deeply divided, and diverging from line in an anterior direction; middle tibiae moderately slender, slightly exceeding femora in length when apposed; calcar of middle tibiae apically curved inward, blunt, thumblike, slender, brownish; middle basitarsi straight, slightly thickened apically, ventral surface beset with several (about 6) bristles along its length, without apical process; second and third mesotarsal segments not apically produced; posterior basitarsi unmodified.

Metasoma with seventh tergite narrowed at apex, indistinctly bilobed, dorsomedian preapical surface with well-defined, almost completely impunctate glabrous area; lateral margins above spiracular lobes inflected, groovelike, receiving dorsal margin of spiracular lobes, grooved surface bare but adjacent dorsal surface weakly produced at apex of spiracular lobes and densely set with stout, spinelike bristles; spiracular lobes moderately inflected, broadly bladelike, length only twice width, separated across venter by about one-half width of either, and with 7th sternite forming a downward arching floor to the 7th segment, opaque except very narrow membranous inner margin, at apex with broad dorsal point; surface of spiracular lobes finely lined, meshlike, glabrous except group of punctures (about 5) each with a single long hair, ventrad to spiracle; latter at upper third, slightly apicad of middle, on edge of strongly developed post-spiracular pit. Sternite 2 with paired processes, sternite 6 bowed downward in apical half, somewhat keel-like anteriorly, apical margin produced to median point; eighth sternite with three terminal processes, median process turned angulately downward, thus comprising slightly less than half the measured total length of sternite, angulately margined at middle on each side; discal process not present.

Genitalia with parameres slender, ventral surface uniformly sclerotized, outwardly set with long hairs; volsellae with cusps slender, distinctly shorter than digitus; digitus stoutly bird-head-shaped; aedeagus head slender, elongate.

This species displays various *S. pulchella* (Cresson) Group (Gillasp, 1959) characteristics. It stands close to *S. tuberculata* (Fox) in the nature of the middle femora of the male, but has paired processes of the second sternite. The males key according to Parker (1929) to *pulchella* with only some difficulty occasioned by the weakly developed characters of the basitarsi, which are straight and only weakly emarginated throughout their length on the inner surface. In *pulchella* the basitarsi are strongly curved as well as inwardly emarginated lengthwise, and the posterior serrate carina of the mesofemora deviates dorsad almost from its origin, rather than traversing the postero-medial aspect of the femora. The female runs to Parker's couplet 37, differing from both options in having the discal marks of the scutum well developed, the mesopleura with yellow almost coextensive with black, and the sternites likewise all with both yellow and black.

*Holotype* female from Mazatlan, Sinaloa, MEXICO, July 18, 1959; *allotype* male from San Blas, Nayarit, Mexico, July 20, 1951, collected on sand; two *paratype* males with same data as allotype except one does not bear a "collected on sand" label; all collected by H. E. Evans. The holotype and allotype are deposited in the United States National Museum, Washington, D. C. The paratypes are in the collections of Cornell University and the author.

#### REFERENCES CITED

- GILLASPY, J. E. 1959. A new bembicine wasp related to *Stictiella tenuicornis* (Fox), with certain phylogenetic considerations. Pan-Pac. Ent. 35: 187-194.
- PARKER, J. B. 1929. A generic revision of the fossorial wasps of the tribes Stizini and Bembicini with notes and descriptions of new species. Proc. U. S. Nat. Mus. 75(5): 1-203, 15 pls.

## A New Genus and Species of Firefly: *Photoctus boliviae* (Coleoptera; Lampyridae)

FRANK A. McDERMOTT, Wilmington, Delaware

Occasionally one encounters a specimen which just does not fit in with accepted character combinations for classification. Such is the case with three male specimens of a lampyrid sent me from Bolivia by Sr. Luis E. Peña, of Santiago, Chile. The remarkable characters of this insect are the much reduced epipleura and an enlarged and quite certainly luminous 8th ventral segment. For this species I propose the new generic name *Photoctus*, a condensation implying the luminous 8th ventral, and the specific name *boliviae*, indicating the country of origin.

### PHOTOCTUS gen. nov.

This genus is differentiated from previously described lampyrid genera by the following combination of characters:

Antennae uniramous, the rami long, flattened, contorted, hairy; antennal sockets prominent, projecting beyond the eyes.

Mandibles apically slender.

Gula membranous in forward portion.

Epipleura reduced to basal traces; no explanate, elytral margins; forward edges deflexed vertically at the humeral angles, becoming level with the disk at about midlength.

Tergites with acute lobes, directed posteriorly.

Eighth ventral segment long and broadly expanded, slightly emarginate at apex; apparently luminous.

### *Photoctus boliviae* sp. nov.

Description of holotype:

Type locality El Palmar, Chopare, Bolivia. Collector Luis E. Peña, September 8, 1956.

Dimensions *ca.* 5.8 mm long by 2.05 mm broad; outline parallel.

Pronotum *ca.* 0.9 mm long by 1.6 mm broad at angles; nearly evenly semicircular; posterior angles acute and projecting be-

hind the middle of the sinuate base. Anterior half of margin internally deflexed, deeply so at sides of eyes; posterior half nearly flat; coarsely and densely punctate; pubescence short and scanty, principally on edges; color transparent brown. Disk convex, smooth, and shining, with scattered hairs; basal half of convex area consists of a trapezoidal brown spot not quite reaching base, with a median longitudinal channel; convexity extends forward over eyes, with a short median carina.

Scutellum dark brown, coarsely punctate, apex broadly rounded. Mesonotal plates dull dark yellow.

Elytra 4.85 mm long by 1.02 mm broad; parallel (actually somewhat spread in holotype), brown, densely rugose-punctate and markedly tricostate, the costae almost reaching the apices; no explanate margins and only basal traces of epipleura; the outer edges deflected vertically at the humeral angles and gradually becoming level with the disk at about midlength. Fairly dense, short, oblique pubescence; no secondary pubescence observable.

Tergites all very dark brown, 4th to 7th with posteriorly directed acute lobes. Pygidium black, trilobed, wider and longer than the 8th ventral.

Prosternum dull yellow, mesosternum yellowish brown, metasternum cloudy reddish brown.

Ventral segments 2 to 5 dark brown, 6th with posterior edge pale, and 7th almost entirely so, both broadly emarginate; pubescence short and appressed. 8th ventral as long as 6th and 7th combined, broadly expanded, nearly as wide as 7th and narrowly emarginate in middle of posterior edge; median longitudinal sulcus; pale salmon color.

Legs short; fore and intermediate light brown, posterior darker; tibial spurs absent. First posterior tarsal article as long as the next three combined; 4th with very small pulvilli; 5th nearly as long as first. Claws small, sharp, simple.

Head deeply set in "collar" of the prothorax; frons concave, very dark brown, rugose; interocular margins not divergent; 0.9 mm across eyes and 0.5 mm between them above antennal sockets; eyes large and contiguous below.

Mandibles very small, pale; distal portion slender and very sharp, approaching Green's modified type. Terminal article of maxillary palpi conical and but little thicker than the first three articles; labial palpi very small, terminal crescentic.

Gula membranous in the small forward portion which is visible.

Antennae 2.3 mm long, articles 3 to 10 dark brown, subequal in length, and each bearing a single pale, flattened, hairy ramus 3 to 5 times as long as the article from which it arises, narrowly reniform; rami contorted, not folded fanwise. 11th article similar to the ramus on the 10th. Antennal sockets and mouth parts project forward beyond the eyes.

Abdominal spiracles not discernible; presumably in the pleural fold.

Aedeagus not extracted, but protruded in one paratype, showing a compact conical form with the median lobe visible between the lateral lobes and curved upwards, the tips of all three approximate; two small lateral knobs.

Female unknown.

*Holotype* is being deposited in the U. S. National Museum as No. 65674; one *paratype* in the California Academy of Sciences, and one in my collection. The paratypes are slightly smaller than the holotype, and one is somewhat less strongly pigmented; the 6th ventral may be entirely brown.

It would be very interesting to find the female of this species; probably larviform and brightly luminous. The luminous conduct of the male was not reported.

## Concerning the Neogeophilidae, with Proposal of a New Genus.<sup>1</sup> (Chilopoda: Geophilomorpha: Neogeophilidae)

By R. E. CRABILL, JR., U. S. National Museum, Smithsonian Institution, Washington, D. C.

(Continued from p. 159)

### *Cryptostrigla silvestri*, new species

Holotype: ♀. GUATEMALA: Department of Alta Verapaz, Semococh (according to O. F. Cook's note, about 48 km. south-east of Coban). G. P. Goll, leg. U. S. National Museum catalogue of myriapod types: 2606; chilopod type C-147; see slides StC: 76 and 77.

INTRODUCTORY. Length, about 32 mm. Pedal segments, 69. Body shape: Essentially of uniform width, the final 4-5 segments slightly attenuate. Color: Considerably discolored from long immersion in alcohol, hence uniformly sordid light brown.

ANTENNAE. Each is broken; left with 5 articles, right with 4 articles. Each basal article much wider than long, the remaining articles approximately as long as greatest width. Vestiture evidently becoming suddenly denser on the fifth article. CEPHALIC PLATE. Greatest length, 0.544 mm; greatest width, 0.579 mm, thus somewhat wider than long. Shape: Anteriorly broadly pointed, the two sides meeting to form an obtuse angle; laterally strongly, evenly excurved; posterior margin essentially straight. Areolation coarse. Without frontal or other sutures or sulci. Setae short and sparsely disposed. A narrow, central portion of the prebasal plate is exposed. CLYPEUS (Fig. 6). Paraclypeal sutures nearly straight; complete (not curving postero-laterally as in *Silvestri's* figure of *primus*). Setae, few, as shown; prelabral setal pair absent. Clypeal areas and plagulae absent; areolation coarse and essentially uniform. Each bucca well-defined by strong sutures; each with a weak trans-buccal suture; anteriorly with a few small setae. LABRUM (Fig. 6). Consisting of one obscure, weak, hyaline, undivided piece

that projects posteriorly in a gentle convex arc; labral teeth very short and delicate, hyaline. Labrum continuous on each side with a delicately sclerotized bar (part of the clypeus) that meets each labral fultura. MANDIBLE (Fig. 1). Shaft relatively short; body of the mandible relatively long and massive; distally with a row of simple hyaline teeth, these very long and flat, rather blunt. FIRST MAXILLAE (Fig. 2). Coxosternum completely divided medially into right and left halves; lappets absent. Each coxosternal half surmounted by a broad, lobelike structure (which may represent a highly modified telopodite); each lobelike structure apically with an indistinct membranous area but otherwise without sutures, divisions, etc.; lappets absent. SECOND MAXILLAE (Fig. 2). Coxosternum medially rather narrow, neither divided nor suturate midlongitudinally; postero-laterally somewhat extended; entire posterior margin weakly areolate and regionally membranous; metameric pore openings conspicuous. Telopodite consisting of three distinct articles; basal article entirely without dorsal and ventral condyles; third article rather ovate in outline; apical claw short and broad, pointed, not excavate, anterior edge smooth but posterior edge with about 3 sharp teeth, thus giving claw superficially a bifid appearance (Fig. 8).

PROSTERNUM (Fig. 3). Very broad. Pleuroprosternal sutures complete, terminating dorsolaterally. Abortive subcondylic sclerotic lines present, these continuous with the pleuroprosternal sutures posteriorly but not passing to or toward their respective prehensorial condyles. Anterocentrally with a pair of obscure but well-sclerotized and rounded denticles. PREHENSORS (Fig. 3). When flexed, falling far short of anterior cephalic margin. Denticles absent on all articles. Ungula long and extraordinarily straight, falciform; dorso-ventrally very flat, bladelike; posterior edge finely dissected to form about 6 tiny, irregular serrations. Poison calyx located at upper end of trochanteroprefemur, cordiform in shape; its duct passing along anterior edge of ungula to open far short of apex. Poison gland very long, passing out of trochanteroprefemur, apparently extending posteriorly nearly as far as 1st pedal segment.



**TERGITES.** Basal plate anteriorly weakly concave to reveal a small portion of prebasal plate centrally. Remaining tergites coarsely areolate, very sparsely setose; without sulci. **PLEURITES.** Agreeing closely with those of *E. mexicanus* (Silvestri's Figs. 1-5, p. 357). Paratergites absent. Spiracles on anterior third of body weakly horizontally elliptical, thereafter becoming rounder. **LEGS** (except ultimates). First legs only slightly shorter and thinner than those following. All legs short and notably robust, not becoming longer or less robust posteriorly on body. Setae short and sparse but more numerous than on tergites and sternites. Pretarsi (Fig. 4): Each fundamentally consisting of a rather bulbous base and a prominent claw proper;

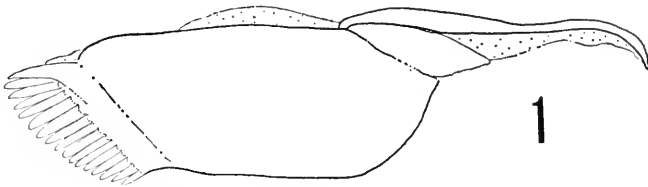

*Cryptostrigla silvestri*, new species, holotype.

1. Left mandible (inner surface).

claws proper from the 1st through the 33rd each with a conspicuous antero-ventral, ventrally directed tooth, tooth of 1st pretarsus small, thereafter ventral teeth increasing in size, becoming smaller again on the 31st and 32nd pretarsi; each tooth-bearing pretarsus with minute serrations on the ventral edge of claw proper; each pretarsus (1-68) with two basal accessory spines, the posterior always minute, the anterior very robust and long on those pretarsi with ventral teeth (on 1 through 33), thereafter becoming smaller and thinner. **STERNITES.** Sulci, sutures, carpophagus-structures, porefields, depressions, metasternite projections all absent. Setae short and sparse. Areolation weak. On anterior third of body the intersternites are weakly divided midlongitudinally; on posterior two-thirds of

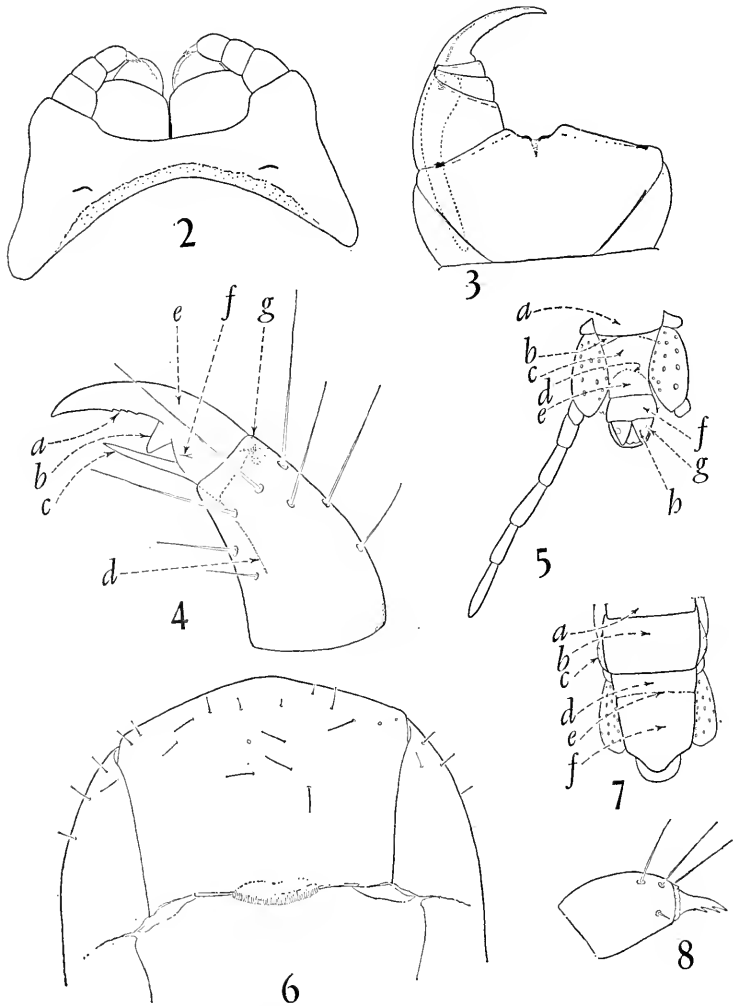

## EXPLANATION OF FIGURES

*Cryptostrigla silvestri*, new species, holotype.

2. First and second maxillae (ventral aspect, setae deleted).
3. Prosternum and right prehensor (ventral aspect).
4. Pretarsus and tarsus of 14th left leg (posterior surface, all setae shown). a, minute serrulations on plantar edge of claw proper. b, ventral tooth of claw proper. c, hypertrophic anterior accessory spine. d,

body intersternites become wider anteroposteriorly, more band-like; undivided centrally.

ULTIMAE PEDAL SEGMENT (Figs. 5, 7). Pretergite intimately fused with tergite proper; the suture separating them is persistent but vestigial and weak; pretergite evidently without pleurites. Tergite: Greatest length exceeds greatest width; sides nearly parallel, weakly convergent; posterior margin medially extended to form a blunt point, the two sides (of the rear margin) thus forming an obtuse angle. Presternite intimately fused with sternite, the vestigial suture separating them is present but discernible with difficulty. Sternite: Sides weakly convergent; the *true* posterior margin medially very deeply excavate, the two corners extended posteriorly in long sharp points; the sternite intimately fused with the pregenital sternite, the intervening suture barely discernible but persistent. Coxopleuron: Moderately inflated; dorsally, laterally and ventrally with small, irregularly disposed freely-opening pores; without porepits of parasternal fossae; setae short and very sparse. Leg: Notably longer and thinner than penult leg; with 6 articles distal to coxopleuron; setae short and somewhat more numerous than on other legs; tarsus consisting of two articles, the distotarsus slightly longer than the proximotarsus; pretarsus represented by a minute sclerotic point (seen only at  $6.5\times$ ), hence an unguiform or tuberculate pretarsus is absent.

---

(in dashes) depressor tendon of the pretarsus. e, claw proper of the pretarsus. f, minute, atrophied posterior accessory spine. g, (in dashes) condyle of pretarsus.

5. Ultimate pedal segment and postpedal segments (ventral, setae deleted). a, penultimate pedal sternite. b, presternite of ultimate pedal segment. c, ultimate pedal sternite. d, vestigial, extremely obscure but persistent suture separating the true ultimate pedal sternite (c) and the pregenital sternite (e). e, pregenital sternite. f, genital sternite. g, (in dashes) concealed terminal pore. h, gonopod.

6. Clypeus, labrum, and right and left buccae (ventral aspect, all setae shown).

7. Rear body segments (dorsal aspect, setae deleted). a, pretergite of penultimate pedal segment. b, tergite of penultimate pedal segment. c, last spiracle of left side. d, pretergite of ultimate pedal segment. e, obscure transverse suture separating pretergite (d) and tergite (f). f, tergite of ultimate pedal segment.

8. Third article and claw of 2nd maxillary right telopodite (ventral aspect, all setae shown).

POSTPEDAL SEGMENTS (Fig. 5). Pregenital sternite antero-posteriorly very long, passing forward to and fusing intimately with the ultimate pedal sternite from which it is separated by a vestigial, obscure suture, thereby causing the last pedal sternite to appear much longer than it actually is. Each gonopod is conical, long; entirely without a discernible interarticular suture or other indication of division, hence is secondarily unarticulate. Terminal pores present, small, concealed.

On the Rank and Possible Affinities of the Neogeophilidae.—The real importance of the discovery of this specimen derives from the unusual opportunity it affords for the direct examination of a member of this peculiar and systematically unsettled group. Careful examination of the animal testifies to the thoroughness of Silvestri's morphological diagnosis; as we have seen, the accuracy of his report is questioned pertinent only to four points, none of which would alter Silvestri's original contention that the group is suprageneric in rank. However, my examination of the single specimen, together with a careful reconsideration of Silvestri's published data, at this time do not permit any other *confident* conclusion than his own, that the rank of the group is probably suprageneric. For reasons explained below it seems preferable for the time-being to regard the neogeophilids as members of a distinct, aberrant family within what I shall call the geophilid-sogonid-gonibregmatid complex of families.

It seems clear that, while belonging to this family complex, the neogeophilids appear to be referable to no one of these families, at least as they are currently defined. At the same time, many of the neogeophilid structures *individually* are reminiscent often of closely similar counterparts that are discernible within this great suprafamilial section of the Geophilomorpha.

The problem of determining the rank and affinities of the Neogeophilidae is by no means reducible merely to one of deciding which is the best and most reasonable of several alternatives in the light body of well-understood and digested morphological information whose details are familiar to everyone. On the contrary, the interpretive problem is necessarily super-

imposed and dependent upon a much more formidable one in this case: many of the most critical facts upon which our inductions must depend are actually representative of a persistent legacy of deficient information which is further complicated by frequent breakdowns in interpersonal understanding. First, there are huge gaps in our knowledge of the full spectrum of the Geophilomorpha: certainly, many groups and species still await discovery. Secondly, in the case of the majority of recognized groups and species we must remain ignorant of the nature, or even of the existence, of many critical diagnostic features if, as is often unavoidable, we must depend for full, precise information upon published descriptions. Finally, it is not infrequently true that even when critical features are treated, their explication is so loose and imprecise, so subjective and cryptic, or even so faulty as to preclude the reader's gaining an accurate or sufficiently detailed understanding of them.

These several difficulties create a particular problem for the categorical assessment and group assignment of the neogeophilids whose conceivable closest relatives as groups are themselves often systematically unsettled, descriptively obscure, and evidently poorly known in terms of the species and supraspecific groups that exist but are undiscovered. The particular problem that is posed is how to interpret the structures about which we believe we have reasonably accurate, meaningful information under these circumstances. Specifically, are these presumably homeomorphic structures evolutionarily conservative, being derivative from a single and immediate preexisting source, or are some or all of them convergent and polyphyletic, having been derived independently, compelled alike by adaptive pressures in separately evolving, remotely-related lines?

Under the circumstances, and with reference to the Neogeophilidae, it seems impossible to settle this question now. We do not know enough about a sufficient number of structures and structural complexes. We do not know enough about the geophilidiform centipedes to be able to distinguish between convergencies and immediately derived structures and forms. At the same time, it is desirable to make mention of some homeo-

morphic characters that eventually may or may not prove to signify close phylogenetic linkages between the neogeophilids and certain other geophilidiform groups.

In general body habitus the Neogeophilidae bear an undeniable resemblance to the Sogonidae and some resemblance to the Dignathodontidae, although their overall similarity, e.g., in head and body shape, to the latter may well be only superficial and adaptively convergent.

A rather homogeneous, poorly-known assemblage of geophilid-like centipedes, the sogonids, apparently are restricted to the more northern New World tropics and to adjacent parts of North America where they are evidently incursive from the south. Established as a family and almost entirely described by Professor Chamberlin, the Sogonidae are clearly abundant in the neotropics where many new groups and species probably await discovery. Like the neogeophilids, they are all small, delicate creatures. Tiny short heads, delicate prehensors, simple and apparently vestigial labra,<sup>2</sup> simple mandibles and, reportedly in some sogonids, aberrant maxillary configurations suggest a general similarity whose explanation on the grounds of immediate evolutionary derivation, however, can hardly be very convincing in our present state of knowledge. Nonetheless, while differing in several critical features, the two groups, as

<sup>2</sup>The sogonid labrum has been inaccurately described repeatedly. Originally Chamberlin described it as being ". . . of a single piece apparently free laterally but fused in the middle; . . ." (1912, p. 432). Completely misinterpreting Professor Chamberlin's statement, Attems wrote the following in his key to families (1929, p. 27): "Oberlippe aus einem ungeteilten Stück bestehend." The first description is cryptic, the second erroneous. On the one hand, they are suggestive of the single, or unipartite, type of labrum, such as that labral type that is characteristic of the schendylids or himantariids. On the other hand, they fail to stress what is really significant, that the sogonid labrum is fundamentally of the tripartite geophilid type, departing from it in the apparent direction of degeneracy. In *Sogona minima* there are two prominent sidepieces which are relatively well-developed, discrete, and widely-separated. Most importantly, the midpiece has either atrophied entirely, or else it has fused imperceptibly with the broadly intruded midclypeal extension. In summary: We can only describe the sogonid labrum as being fundamentally tripartite and lacking a *distinguishable* midpiece.

we know them of course, do appear superficially to be rather similar. It is difficult to ignore the possibility, however remote, that the neogeophilids and sogonids may represent closely-related, aberrant evolutionary experiments that were fragmented together from some ancient geophilid stock. Similarly, the dignathodontids and aphilodontine geophilids perhaps represent separate and now nominate variations upon an original, basic geophilid theme.

The first maxillary coxosternum of the neogeophilids, being totally divided into right and left halves, is curiously suggestive of its homologue in *Himantosoma*, a genus that Attems placed in Gonibregmatidae but which Verhoeff regarded as the basis of a separate family. Again, whether these divided coxosterna are merely convergent or are evolutionarily derivative from a common precursor is impossible to determine now. It may, however, be significant that *Himantosoma* lacks the bizarre anterior maxillary lobes that signalize all known neogeophilids.

As I have noted above, the neogeophilid labrum appears by direct inspection to be simple and degenerate and reminiscent of that of the sogonids, inasmuch as that is also evidently hypertrophied. This is not to imply that they resemble each other very closely; they do not. At the same time, essentially the neogeophilid type of labrum may be seen in certain Gonibregmatidae. For that matter, the same labral type is found in certain ballophiline Schendylidae, which do not seem very closely related to the whole section of the Geophilomorpha here under discussion. Without much doubt, quite similar, if not occasionally identical, labra have arisen *independently* at least in some unrelated geophilomorphs.

The neogeophilid mandible, equipped only with a simple row of delicate hyaline and homogeneous teeth, apparently can tell us little, except that the neogeophilids *may be* more closely related to the geophilid-dignathodontid-gonibregmatid-sogonid complex than to any other. But even in this regard we are hardly entitled to conclude with an emphatic finality that this simple type of mandible *in every instance* can only be indicative of monophyletic origins. It is by no means impossi-

ble that, let us say, through convergency, or by whatever mechanism, the simple geophilidiform mandibles was developed independently in remotely related geophilomorphs. If we ignore the venerable mandibular criterion momentarily, then several rather striking structural similarities existing between the neogeophilids and oryids could possibly take on new significance.<sup>3</sup>

The neogeophilid pretarsi are evidently unique. The extraordinary ventral teeth, hypertrophic anterior accessory spines, and serrulate plantar edges must function as a unit to facilitate traction upon or adherence to the surfaces over which their possessors move. Analogous, though evidently not wholly homologous, adaptive devices are known to occur in some other geophilomorphs. For instance, the gonibregmatid genus *Eucratonyx*, while lacking a ventral pretarsal tooth, has a conspicuously introrse claw proper which, in conjunction with a hypertrophic anterior accessory spine, probably affords a firmer foothold for locomotion over rough surfaces or for stationary clinging. Again, massive development of the claw proper and of one or both of its accessory spines has been noted in certain schendylids (e.g., *Pectiniunguis*). It seems quite likely that cryptophiles such as these geophilomorphs would be inclined to evolve efficient hold-fast devices independently: their existence depends upon adaptation to a variety of crevice-cranny habitats wherein, one would think, adaptive pressures would place a premium upon the ability to squeeze through tight, narrow confines and to anchor firmly against forceful removal by predators.

Summing up: The structures that signalize the known Neogeophilidae tell us little conclusively about their interfamilial affinities. Many of these structures could very well represent adaptive convergencies that obscure rather than illuminate the ranks and affinities of groups. While most individual neogeophilid features have often quite similar counterparts in various other geophilomorph groups, in no case is there a concordance of structural identities that could justify an unequivocal statement

<sup>3</sup> By the same token, if we ignore the mandibular criterion, a number of features in certain oryids suggest possibilities that have not received serious consideration.



of close phylogenetic affinity at this time. It is conceivable that the neogeophilids and sogonids could reflect a community of descent, although, admittedly, this is a highly speculative suggestion for which present evidence is limited and frankly unconvincing.

#### A REVIEW OF THE NEOGEOPHILIDAE

##### Neogeophilidae

Neogeophilinae, Silvestri, 1918, p. 352.

Neogeophilidae, Attems, 1926, p. 365.

**Distinguishing Criteria.**—1st maxillary coxosternum completely divided into right and left halves, each half surmounted by a large, uniarticulate lobe. Pretarsi of the more anterior legs each ventrally with a prominent tooth that is continuous with the claw proper. First article of second maxillary telopodite basally without condyles.

**Extended Characterization.**—Antennae slightly attenuate distally. Cephalic plate very slightly wider than long to slightly longer than wide; frontal suture absent. Prebasal plate at least slightly exposed. Clypeus with complete paraclypeal sutures; without clypeal areas or plagulae. Labrum comprising a delicate undivided bar, wholly amalgamated with postero-central clypeus, with delicate hyaline teeth, these long, flat, rather blunt; proximal shaft relatively short when compared with the longer, heavier distal dentigerous portion. First maxillae: Coxosternum medially completely divided, the right and left sides thus entirely discrete; each coxosternal half with a large lobate structure in place of the usual structures; lappets absent. Second maxillae: Coxosternum medially undivided, not sutured; telopodite basal articles without discernible condyles; apical claw with a few delicate spiniform projections arising from posterior edge. Prosternum with complete pleuroprosternal sutures; with or without complete subcondylic sclerotic lines. Prehensors: When closed falling far short of anterior cephalic margin; articles without denticles; unguulae long and falcate, flattened dorso-ventrally, posterior edge finely, irregularly serrulate.

Tergites not sulcate. Paratergites absent. Legs robust and short. Pretarsi of the more anterior legs each with a conspicuous ventral tooth and equally conspicuous hypertrophic anterior accessory spine. Sternites not sulcate; without porefields or carpophagus-structures; the more posterior intersternites broadly bandlike and not suturate midlongitudinally. Ultimate pedal segment: Pretergite either separated from its tergite by a distinct transverse suture, or, if fused intimately with tergite, separated from it by an obscure suture or else apparently without an intervening suture. Coxopleuron with freely opening pores, without dorsal or ventral porepits or porigerous fossae; moderately inflated. Sternite either distinguishable from or intimately fused with the pregenital sternite; ultimate tarsus uniaarticulate in the males, biarticulate in the females; pretarsus essentially absent. Terminal pores present but concealed. Each gonopod biarticulate (with persistent intervening suture), or uniaarticulate (without intervening suture).

Range: Known only from Mexico and Guatemala.

Known from three monotypic genera, as follows.

#### NEOGEOPHILUS Silvestri

*Neogeophilus* Silvestri, 1917, p. 352.

Type-species: *Neogeophilus primus* Silvestri, 1917. (Original designation and monotypic.)

Diagnosis.—With the characters of the family, of which the following signal characters are distinctive. (1) Head slightly longer than wide. (2) Paraclypeal sutures apparently arching outward, apparently not terminating on the rear clypeal margin (see discussion under foregoing Notes). (3) Prosternal denticles absent. (4) Prosternal subcondylic sclerotic lines passing to and essentially meeting their respective condyles. (5) Ultimate pedal pretergite and tergite, and sternite and pregenital sternite separated by distinct sutures. (6) Female gonopods biarticulate.

Inclusive species: Known only from *N. primus* Silvestri: with the characters of the genus, in addition ♂ with 81 pedal

segments, 34 mm. long; only known and type locality, Cuernava, State of Morelos, Mexico.

### IVALLOGEOPHILUS Silvestri

*Evallogophilus* Silvestri, 1917, p. 355.

Type-species: *Evallogophilus mexicanus* Silvestri, 1917. (Original designation and monotypic.)

Diagnosis.—With the characters of the family, of which the following signal characters are distinctive. (1) Head considerably longer than wide. (2) Paraclypeal sutures terminating posteriorly on the rear clypeal margin. (3) Prosternal denticles present. (4) Prosternal subcondylic sclerotic lines passing to and essentially meeting their respective condyles. (5) Ultimate pretergite and tergite, and sternite and pregenital sternite intimately fused, apparently without intervening sutures. (6) Female gonopods biarticulate.

Inclusive species: Known only from *E. mexicanus* Silvestri: with the characters of the genus, in addition ♂ with 63, ♀ with 67 pedal segments; to 30 mm. long; only known and type locality, "Jalapa" (in full, Jalapa Enriquez), State of Veracruz, Mexico.

### CRYPTOSTRIGLA, new genus

Type-species: *Cryptostrigla silvestri*, new species. (Present designation and monotypic.)

Diagnosis.—With the characters of the family, of which the following signal characters are distinctive. (1) Head somewhat wider than long. (2) Paraclypeal sutures terminating on clypeal margin. (3) Prosternal denticles present. (4) Prosternal subcondylic sclerotic lines abortive, not passing across prosternal corner to or toward their respective condyles. (5) Ultimate pretergite and tergite, and sternite and pregenital sternite intimately fused, the intervening sutures still discernible. (6) Each female gonopod single, the two articles having fused without trace of intervening suture.

Inclusive species: Known only from *C. silvestri*, new species:

with the characters of the genus; in addition ♀ with 69 pedal segments, 32 mm. long.; only known and type locality, Semo-coch, Department of Alta Verapaz, Guatemala.

## REFERENCES

- ATTEMS, C. GRAF VON. 1926. Kükenthal-Krumbachs Handbuch der Zoologie 4 (3 + 4): 241-402. 1929. Geophilomorpha, in Das Tierreich, Lief. 52: 1-388.
- CHAMBERLIN, R. V. 1912. The Geophiloidea of the South-eastern States. Bull. Mus. Comp. Zool. Harvard 54: 405-436.
- SILVESTRI, F. 1918. Descrizione di due nuovi generi di Geophilidae (Chilopoda) del Messico. Boll. Laborat. Zool. Gener. Agrar. Portici 12: 352-360.

---

## Supplementary Records of Meloid Beetles (Coleoptera) of the West Indies

By RICHARD B. SELANDER and JOHN K. BOUSEMAN,  
Department of Entomology, University of  
Illinois, Urbana

Since the completion of our report on the Meloidae of the West Indies (Selander and Bouseman, 1960, Proc. U. S. Nat. Mus., vol. 111, pp. 197-226), we have received from Patricia and Charles Vaurie, American Museum of Natural History (AMNH), a series of specimens collected by them in 1960 on the islands of Guadeloupe, Jamaica, and Martinique and from M. W. Sanderson, Illinois Natural History Survey (INHS), a series of specimens collected by him in 1959 on Cuba. A few other specimens of West Indian meloids have also come to our attention. In publishing the records of this supplementary material, we again take pleasure in acknowledging the co-operation of our colleagues.

In order to avoid repetition, we will list here the localities and dates for the Vaurie material. Guadeloupe: Domaine Duclos, 600 ft., June 24-28 and July 7; Les Saintes, Terre de Haut,

July 2-5; and Matouba, 1900 ft., June 29. JAMAICA: Hardware Gap, 4800 ft., July 13-15. MARTINIQUE: Absalon, rain forest, June 16; Diamant, June 17; and Morne Rouge, June 13.

**Cissites maculata** (Swederus). GUADELOUPE: Domaine Duclos, AMNH, 2; Les Saintes, Terre de Haut, AMNH, 1. HISPANIOLA: Sánchez, Dominican Republic, June 3-12, 1915 and February 1916, AMNH, 3.

**Pseudozonitis marginata** (Fabricius). GUADELOUPE: Domaine Duclos, AMNH, 64; Matouba, AMNH, 3. JAMAICA: Hardware Gap, AMNH, 1. MARTINIQUE: Absalon, AMNH, 5; Diamant, AMNH, 3; Morne Rouge, AMNH, 3. PUERTO RICO: Mayagüez, May 1924, Cornell University, 1.

The specimens from Guadeloupe are assignable to our color class 0 and those from Jamaica and Puerto Rico to class 2. In the series from Martinique, two specimens are representative of class 0, one of class 2, two of class 3, and six of class 4. One of the specimens of the last class has the pale elytral vitta reduced to half its usual width. In a few of the specimens from Guadeloupe and in one from Martinique the head is fuscous. Females outnumber males in the new material four to one.

**Pseudozonitis obscuricornis** (Chevrolat). GUADELOUPE: Domaine Duclos, AMNH, 12; Matouba, AMNH, 1. JAMAICA: Kingston, 1958, M. Locke, Selander collection, 1.

The specimen from Jamaica is heavily marked. Those from Guadeloupe have the elytral vitta either poorly developed or absent.

**Nemognatha punctulata** LeConte. CUBA: Lower slopes of Loma (Pico) del Gato, Sierra Maestra, Oriente Province, May 26, 1959, on *Compositae*, M. W. Sanderson, INHS, 9; between Santa Lucía and Nuevitas, Camaguey Province, June 8, 1959. M. W. Sanderson, INHS, 1.

An annotation should be made to couplet 6 of our key indicating that the color of antennal segment I is variable in this species. In all the specimens that we studied earlier this segment is yellow. However, in three of the specimens recorded above it is piceous and in four it is completely black.

**Melanagromyza tiliae (Coud.) (Diptera: Agromyzidae) Reared from Linden Bark Galls at London, Ontario**

By W. W. JUDD, Department of Zoology, University of Western Ontario, London, Ontario

On March 18, 1957, six twig galls were collected from basswood trees, *Tilia americana*, on the campus of the University of Western Ontario at London, Ontario. They were identified as Linden Bark Galls by using keys and descriptions in Felt (1940). Each gall was a smooth swelling along the side of the twig and was one-half an inch long, three-sixteenths of an inch wide and bulged one-eighth of an inch above the surface of the twig. The bark covering a gall was as smooth as the bark on the surrounding twig and was of the same color. One gall was dissected and was found to be composed internally of soft wood. The remaining galls were kept in the laboratory in a corked vial. On April 9 a fly emerged from one of the galls through a circular hole 1.5 mm. in diameter. On April 10 the other four galls were dissected and yielded one brown puparium each. The fly was identified as *Melanagromyza tiliae* (Coud.) by Mr. G. E. Shewell, Entomology Research Institute, Department of Agriculture, Ottawa. This species was described by Couden (1908) from specimens reared from twigs of basswood and its taxonomic relationships have recently been discussed by Shewell (1953) and Frick (1957).

On September 7, 1957, seven more galls were collected from basswood on the university campus and a few days later three more adult *M. tiliae* emerged from them. The four specimens reared at London are deposited in the collection of the Department of Zoology, University of Western Ontario. Felt (1940) records that this fly produces its gall in summer. The specimens from which the species was described by Couden were reared from galls in Missouri in April (Couden, 1908; Frick, 1957), and the first fly reared at London emerged in the laboratory in this month. It is thus evident that this insect habitually overwinters in the gall on the twig.

## REFERENCES

- COUDEN, F. D. 1908. Proc. Entomol. Soc. Washington 9: 34-36.  
FELT, E. P. 1940. Plant galls and gall makers. Comstock Publ. Co. Ithaca.  
FRICK, K. E. 1957. Ann. Entomol. Soc. Amer. 50: 198-205.  
SHEWELL, G. E. 1953. Can. Entomol. 85: 462-470.
- 

## ***Psectra diptera* (Burmeister) in Wisconsin (Neuroptera: Hemerobiidae)**

By ALVIN L. THRONE, University of Wisconsin, Milwaukee

*Psectra diptera* (Burmeister) has been recorded from Austria, Denmark, England, Finland, Germany, Holland, Ireland, Italy, Scotland, Siberia, Sweden, Switzerland and the Ukraine (Killington, 1936). It has been recorded from the northeastern United States, as far west as Michigan and as far south as Virginia and West Virginia, and from Ontario (Carpenter, 1940). It has also been recorded, as *Hemerobius delicatulus* Fitch, from Illinois (Hagen, 1861). Banks, 1905, refers to specimens from Ithaca, New York, the Agricultural College, Michigan, and Franconia, New Hampshire. He also mentions Fitch's specimens collected in northern Illinois in October. Recently new records have been reported from Connecticut, Maryland and Virginia (MacLeod, 1960).

In my extensive collecting of Neuroptera in Wisconsin, supported by the Research Committee of the University of Wisconsin on funds from the Wisconsin Alumni Research Foundation, I have obtained four specimens of *Psectra diptera*. All of the specimens I collected are macropterous. They were all taken in my backyard in Shorewood, a residential suburb of Milwaukee.

It is interesting to note that all four of my specimens were taken in a light trap. The trap was hung from a clothes line with the top of the funnel approximately three and a half feet from the ground. Killington suggests that both micropterous

and macropterous forms are most likely unable to fly. Mac Leod gives evidence that perhaps some individuals are able to fly. The position of my trap with reference to the ground, building and taller plants and the nature of the trap itself strongly suggest that macropterous individuals can fly.

Carpenter (*op. cit.*) gives the average wing length as 6 millimeters. Killington (*op. cit.*) gives total wing expanse as about 7 mm. and reports Banks as giving a wing expanse of 5-6 mm. Mac Leod (*op. cit.*) in measuring ten Nearctic specimens found the average length of forewing as  $3.82 \pm 0.25$  mm. and total wing expanse as  $8.57 \pm 0.54$  mm.

The following wing measurements of the specimens I collected were made with an ocular micrometer.

Date Collected	9-VIII-1957	9-VIII-1957	27-VIII-1958	2-VIII-1959
Length of forewing	5.08 mm.	3.85 mm.	4.00 mm.	4.61 mm.
Body width at mesothorax	1.08	0.77	0.77	0.92
Total wing expanse	11.24	8.47	8.77	10.14

#### LITERATURE CITED

- BANKS, N. 1905. Trans. Am. Ent. Soc. 32: 21-51.  
 CARPENTER, F. M. 1940. Proc. Amer. Acad. Arts Sci. 74: 193-280.  
 HAGEN, H. 1861. Smithsonian Inst. Miscell. Coll.: Washington, D. C.  
 KILLINGTON, F. J. 1936. A monograph of the British Neuroptera. Volume I. Ray Soc.: London.  
 MAC LEOD, E. G. 1960. Entom. News 71: 231-236.

### Review

A MANUAL OF COMMON BEETLES OF EASTERN NORTH AMERICA. By Dillon, E. S., and L. S. Dillon. Pp. viii + 884; 554 text figures and 85 plates (4 colored). Row, Peterson and Co., Evanston, Illinois, 1961. Price, \$9.25.

Here, at long last, is a really workable manual of beetles, and one that seems to have just about every imaginable virtue.



Heretofore Blatchley's was the standby, but, using it, the inexperienced often ended with more incorrect than correct determinations. In this book, the Dillons have selected the 1200 commonest beetles in 64 families, and keyed them carefully to families, genera, and species. The diagnostic features are illustrated by 554 text figures, and there is a habitus picture and a description of each species. The species selected, it is believed, include about 90% of all beetles commonly taken in the region; for most of the remainder the bibliography, arranged by families, will lead one to recent revisions and synopses.

The very form and appearance of this manual add to the pleasure of using it. It is not too bulky (page size,  $5\frac{1}{2}'' \times 8\frac{1}{4}''$ ) and is neatly bound in semi-flexible cloth with rounded corners. It should make many new friends for the Coleoptera, including also hobbyists who will find delight in collecting beetles and seeking out their names.—R. G. SCHMIEDER.

---

### Corrodentia in Cliff Swallow Nests

By WILLIAM F. RAPP, JR., Nebraska State Department of Health, Lincoln, Nebraska

A number of Corrodentia were obtained recently from cliff swallow nests (*Petrochelidon pyrrhonota pyrrhonota*) by means of a Berlese funnel. These nests had been collected from the Nebraska end of the Yankton bridge (South Yankton, Cedar County, Nebraska) on August 11, 1955.

The specimens were submitted to Dr. Kathryn B. Sommerman who determined them as belonging to the *Liposcelis bostrychophilus* complex, family Liposcelidae.

It is interesting to note that Hicks (1959)<sup>1</sup> does not list *L. bostrychophilus* as occurring in the nests of the cliff swallow. However, *L. divinatorius* has been reported as occurring in the nests of other swallows of the Family Hirundinidae.

<sup>1</sup>HICKS, E. A. 1959. Occurrence of insects in birds' nests. Iowa State College Press.

# Entomologist's Market Place

## ADVERTISEMENTS AND EXCHANGES

Advertisements of goods or services for sale are accepted at \$1.00 per line, payable in advance to the editor.

Notices of wants and exchanges not exceeding three lines are free to subscribers.

All insertions are continued from month to month, the new ones are added at the end of the column, and, when necessary, the older ones at the top are discontinued.

---

**Butterflies.** Wish to exchange specimens for Japanese species. Please write to Ichiro Nakamura (Boy, age 16), 26 Aza-Nichiyama Obayashi Takarazuka-shi, Hyogo-Ken, Japan.

**Phasmidae** of nearctic area desired alive. Purchase or trade, drawing on large stock of major orders, worldwide. Domminck J. Pirone, Dept. Entomology, Cornell University, Ithaca, N. Y.

**Nitidulidae** and **Rhizophagidae** wanted in exchange for European beetles of all families. O. Marek, Zámberk 797, Czechoslovakia.

**Wanted and Needed.** We are compiling a history of entomology, and particularly, at present, of the amateur insect clubs that flourished 50 to 75 years ago. Will you who have knowledge of such early clubs or societies advise me, giving facts on the time of existence, members, etc., which you may have. J. J. Davis, Dept. of Entomology, Purdue University, Lafayette, Indiana.

**Cockroaches (Blattoidea)** of Japan, Okinawa, Formosa (Taiwan), and the Philippines are being studied in cooperation with Dr. K. Princis. Loans of specimens from that area are desired. A. B. Gurney, U. S. National Museum, Washington 25, D. C.

**Orthoptera. Gryllinae** (except domestic sp.) and **Pyrgomorphinae** of the world wanted in any quantity for work in morphology, taxonomy, cytology, and experimental biology; dry, or in fluid, or living. Write D. K. Kevan and R. S. Bigelow, Dept. of Entomology, McGill University, Macdonald College, Quebec, Canada.

**Beetles** of the world wanted, all species in exchange for American beetles, moths and butterflies. James K. Lawton (age 18), 7118 Grand Parkway, Wauwatosa 13, Wisconsin.

**Used genuine Schmidt boxes**, excellent condition, at less than half price. H. W. Allen, Box 150, Moorestown, N. J.

# Important Mosquito Works

**MOSQUITO ATLAS. Part I.** The Nearctic Anopheles, important malarial vectors of the Americas, and *Aedes aegypti* and *Culex quinquefasciata*

**MOSQUITO ATLAS. Part II.** The more important malaria vectors of the Old World: Europe, Asia, Africa and South Pacific region

By Edward S. Ross and H. Radclyffe Roberts

Price, 60 cents each (U. S. Currency) with order, postpaid within the United States; 65 cents, foreign.

---

## KEYS TO THE ANOPHELINE MOSQUITOES OF THE WORLD

With notes on their Identification, Distribution, Biology and Relation to Malaria. By Paul F. Russell, Lloyd E. Rozeboom and Alan Stone

Mailed on receipt of price, \$2.00 U. S. Currency. Foreign Delivery \$2.10.

---

For sale by the American Entomological Society, 1900 Race Street, Philadelphia 3, Pa., U. S. A.

---

## Just Published New Classified Price Lists

Available separates from the TRANSACTIONS OF THE AMERICAN ENTOMOLOGICAL SOCIETY and ENTOMOLOGICAL NEWS, and all titles of the Society's MEMOIRS have been catalogued by author in twelve special price lists in the following categories:

Coleoptera  
Diptera  
Hemiptera  
Hymenoptera  
Lepidoptera  
Memoirs

Neuroptera and Smaller Orders  
Odonata  
Orthoptera-Dermoptera  
Arachnida and Other Classes  
Bibliography-Biography  
General

Lists will be mailed free upon request. Please state specifically which list or lists you require.

**The American Entomological Society**  
1900 RACE STREET  
PHILADELPHIA 3, PENNSYLVANIA

Just Published

**MEMOIRS OF THE AMERICAN  
ENTOMOLOGICAL SOCIETY**

Number 17

**A TAXONOMIC STUDY OF THE  
MILLIPED FAMILY SPIROBOLIDAE  
(DIPLOPODA: SPIROBOLIDA)**

By William T. Keeton

147 pages of text, 37 tables, 2 maps, 18 plates,  
table of contents and index

Spirobold millipeds are probably the most widely known Diplopoda in the United States, being used in many college courses; yet the family has been little studied. This monograph brings together existing knowledge of the group for the first time, and adds much new information gained from critical study of series. The taxonomic history of the family is outlined. External morphology is briefly treated, with emphasis on characters utilized in classification. A summary of current knowledge of life histories is included. The family is redefined, and each genus and species is treated in detail. Particular attention is given to variation and distribution, both of which become more meaningful biologically as a result of synonymizing many species names. Possible phylogenetic relationships of the genera are discussed, and keys to all taxa are provided, with most diagnostic characters illustrated in 18 plates or summarized in 37 tables.

Price \$5.50

---

**THE AMERICAN ENTOMOLOGICAL  
SOCIETY**

1900 Race Street, Philadelphia 3, Penna., U.S.A.

# ENTOMOLOGICAL NEWS

OCTOBER 1961

Vol. LXXII

No. 8

---

## CONTENTS

Froeschner—Revision of <i>Dearcla Signoret</i> .....	197
Stahnke—A new species of scorpion .....	206
Arnett—Onychophora of Jamaica .....	213
Nomenclature Notice .....	220
Book Reviews: .....	221
Facts and theories concerning the insect head Cicindelidae of Canada Western Butterflies	

---

PUBLISHED MONTHLY, EXCEPT AUGUST AND SEPTEMBER, BY  
THE AMERICAN ENTOMOLOGICAL SOCIETY  
PRINCE AND LEMON STS., LANCASTER, PA.  
AND  
1900 RACE STREET, PHILADELPHIA 3, PA.

---

Subscription, per yearly volume of ten numbers: \$5.00 domestic; \$5.30 foreign; \$5.15 Canada.  
Second-class postage paid at Lancaster, Pa.

DIV. INS.  
U.S. NATL. MUSEUM

# ENTOMOLOGICAL NEWS

---

**ENTOMOLOGICAL NEWS** is published monthly, excepting August and September, by The American Entomological Society at Prince and Lemon Sts., Lancaster, Pa., and the Academy of Natural Sciences, 1900 Race Street, Philadelphia 3, Pa., U. S. A.

**PHILIP P. CALVERT**, Editor Emeritus. **R. G. SCHMIEDER**, Editor. Editorial Staff: **H. J. GRANT, JR.**, **E. J. F. MARX**, **M. E. PHILLIPS**, and **J. A. G. REHN**.

**SUBSCRIPTIONS:** Communications and remittances to be addressed to **Entomological News, 1900 Race Street, Philadelphia 3, Pa.**

Prices per yearly volume of 10 numbers.

**Private subscriptions**, for personal use: in the United States, \$5.00; Canada, \$5.15; other countries, \$5.30.

**Institutional subscriptions**, for libraries, laboratories, etc.: in the United States, \$6.00; Canada, \$6.15; other countries, \$6.30.

**ADVERTISEMENTS:** Rate schedules available from the editor.

**MANUSCRIPTS** and all communications concerning same should be addressed to **R. G. Schmieder, Zoological Laboratory, University of Pennsylvania, Philadelphia 4, Pa.**

The receipt of all papers will be acknowledged and, if accepted, they will be published as soon as possible. Articles longer than eight printed pages may be published in two or more installments, unless the author is willing to pay the cost of a sufficient number of additional pages in any one issue to enable such an article to appear without division.

**ILLUSTRATIONS:** Authors will be charged as follows: For text-figures, the cost of engraving; for insert plates (on glossy stock), the cost of engraving plus printing. Size limit, when printed, 4 × 6 inches. All blocks will be sent to authors after printing.

**TABLES:** The cost of setting tables will be charged to authors.

**SEPARATA:** Members of the American Entomological Society may elect to receive, gratis, 25 offprints of their contributions. These will be "run-off-matter," without removal of extraneous matter.

Those members desiring more than 25 separates, and all non-members, will receive no gratis copies. They must obtain all their separates (as reprints, with extraneous matter removed) from the printer at the prices quoted below. Authors must place their order for such separates with the editor at the time of submitting manuscripts, or when returning proof.

Copies	1-4 pp.	5-8 pp.	9-12 pp.	Covers
50	\$4.35	\$6.96	\$10.88	\$4.74
100	5.21	8.26	13.05	6.48
Add'l 100	1.74	2.60	4.33	3.48

Plates printed one side: First 50, \$3.47; Additional 100's, \$2.61.

Transportation charges will be extra.



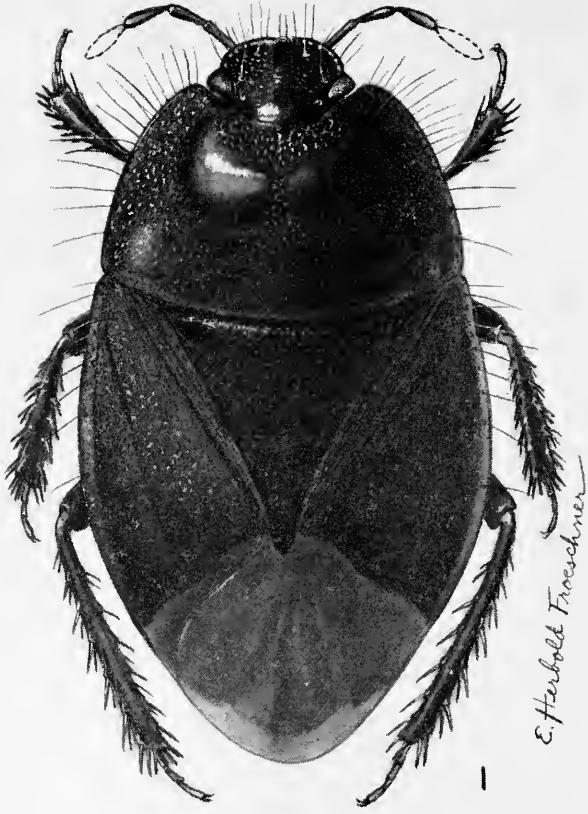

Fig. 1. *Dearcla opercularis* Signoret



# ENTOMOLOGICAL NEWS

---

VOL. LXXII

OCTOBER, 1961

No. 8

---

## Revision of the South African Genus *Dearcla* Signoret with Descriptions of Three New Species (Hemiptera: Cydnidae)<sup>1</sup>

RICHARD C. FROESCHNER<sup>2</sup>

Signoret erected *Dearcla* for his new species *opercularis* from "Simon's Bay" south of Cape Town in Cape Province, Union of South Africa. No additional specimen records of the genus have appeared. This is not too surprising as Signoret's illustration is quite misleading in conveying a picture of the type specimen. When comparison with the type was made the sketch was found to be erroneous in the following particulars which are shown correctly on the plates in the present paper: shape of the meso- and metaevaporatoria; the apical peritreme; the extent of the pronotal calli; the shape of the costa and the outline of the narrowed scutellar apex.

The present paper is offered to correct these errors with a series of carefully executed drawings by my wife, Elsie Froeschner; to bring the literature status of this genus in line with the modern approach to the Cydnidae (as established in my monograph of the Cydnidae of the Western Hemisphere—Proc. U. S. Nat. Mus., 111: 337–680); and to describe three more species

<sup>1</sup> National Science Foundation Grant (NSF G7118) made possible personal examination of type specimens of Cydnidae in European museums and in other ways aided in preparation of this paper.

<sup>2</sup> Dept. Zoology and Entomology, Montana State College, Bozeman, Montana. Contribution from Montana State College Agricultural Experiment Station, M. S. 38, paper No. 528 Journal Series.

PRESENT ADDRESS: Entomology Research Division, Agr. Res. Serv., U.S.D.A., Washington, D. C.

kindly made available to me by Dr. W. E. China of the British Museum of Natural History.

The sublateral setigerous punctures, shape of tarsal segments and trichobothrial arrangements clearly assign this genus to the subfamily Cydninae in the restricted sense as established in the above-mentioned monograph.

#### DEARCLA Signoret

1883 *Dearcla* Signoret, Ann. Soc. Ent. France, (6) 3: 363.

DIAGNOSIS: Among those Cydninae with the shining, elongate, apical peritreme and no impressed subapical pronotal line, this one may be recognized by the long, pointed scutellum whose length is greater than the median length of the pronotum.

DESCRIPTION: Broadly oval. HEAD: Anterior outline a slightly to distinctly flattened semicircle; clypeus and juga equal in length; jugal margins weakly to distinctly but narrowly carinate dorsally; three primary setigerous punctures present; antennae five-segmented; labium reaching between middle coxae, segment II very weakly compressed, not foliaceous. PRONOTUM: Median length about half of basal width; anterior margin broadly and rather shallowly emarginate; transverse impression obsolete; laterally with a single, submarginal row of a variable number (seven to thirty) setigerous punctures. SCUTELLUM: Width slightly or distinctly greater than length, apex acutely prolonged. HEMELYTRON: Areas distinctly defined; membrane occupying about one-third hemelytral length, its length greater than its basal width, reaching to apex of abdomen; costa and exocorium flattened, latter weakly reflexed in basal half; subcostal setigerous punctures two to thirteen; membranal suture weakly bisinuate, lateral angle broadly acute. PROPLEURON: Shining, strongly punctured in depression and on anterior half of front convexity; prosternal carinae virtually absent, the space between them weakly depressed. MESOPLEURON: As in Fig. 7, evaporatorium extends to lateral margin of sclerite along posterior margin. METAPLEURON: As in Fig. 7, evaporatorium reaching more than three-fourths across sclerite, lateral margin nearly

straight; lateral polished area impunctate; osteole opening ventrally at the base of an elongate, polished, apical peritrema. LEGS: Anterior tibia (Fig. 5) moderately flattened, with seven or eight coarse spines dorsally, with tarsus arising at its apex; not generically modified. STERNITES: Not generically modified. TERMINALIA: Male genital capsule opening dorsally, gonostylus quite similar in the males of the three species for which that sex is known (Fig. 2); female plates of the usual pentatomoid type.

TYPE OF GENUS: *Dearcla opercularis* Signoret, monobasic.

DISTRIBUTION: The four species now known occur near the southern tip of Africa: Signoret's species and one new one from the vicinity of Cape Town; the other two from Natal.

DISCUSSION: Each of the four species is known only from one sex. Collections of pairs are needed, especially to determine the relation of the two new species *capensis* and *natalensis*.

Grouping of the species within the genus may be made in two ways with separate characters. Probably the strongest separation of groups is made by the almost complete absence of submarginal setigerous punctures on the head (only the preocular primary one being present submarginally) on *paucivillosa* new species; this is in contrast to the other three species which have such punctures on both juga and subapically on the clypeus. Evaluation of the other feature worthy of note must await further study in certain genera, but it can be pointed out here: in all but *opercularis* there is a weak but evident branch which arises near the middle of vein M and reaches to the apex of the corium.

#### Key to the Known Species of *Dearcla*

1. Juga with submarginal row of setigerous punctures; clypeus with two subapical setigerous punctures.....2  
     Juga without a row of setigerous punctures; clypeus without subapical setigerous punctures. . . . . *paucivillosa* NEW SPECIES
2. Posterior pronotal lobe much duller than polished calli and with fine but distinct punctures all the way to the hind margin; mesocorium with no evidence of a branch of vein M.....*opercularis* Signoret

- Posterior pronotal lobe nearly as shining as polished calli and with widely spaced punctures almost obsolete toward hind margin of pronotum; mesocorium with a weak but evident branch arising near middle of vein M. . . . . 3
3. Pronotum with twenty-five to thirty setigerous punctures in lateral, submarginal row; costa with about fourteen setigerous punctures. . . . . **capensis** NEW SPECIES
- Pronotum with twelve to fifteen setigerous punctures in lateral, submarginal row; costa with seven to nine setigerous punctures. . . . . **natalensis** NEW SPECIES

### **Dearcla capensis** new species

**DIAGNOSIS:** The more than twenty-five submarginal setigerous punctures laterally on the pronotum will separate this species from all others in the genus—none of which have more than fifteen.

**DESCRIPTION** (based on two females). **FEMALE.**—**HEAD:** Length about two thirds width, 1.00 (0.98–1.03) : 1.40 (1.40–1.41); interocular width 0.85 (0.85–0.86); surface with numerous crowded, moderately coarse punctures on juga and anteriorly on vertex; jugum with eight or nine submarginal setigerous punctures; clypeus flattened, with few fine punctures and two subapical setigerous punctures; bucculae punctate, about as high as labial II; antennals, I, 0.26 (0.26–0.26) : II, 0.34 (0.33–0.36) : III, 0.34 (0.33–0.36) : IV, 0.37 (0.36–0.39) : V, 0.40 (0.40–xx); labials, I, 0.46 (0.46–0.46) : II, 0.57 (0.55–0.60) : III, 0.54 (0.54–0.55) : IV, 0.39 (0.38–0.40). **PRONOTUM:** Length: width :: 1.71 (1.70–1.72) : 4.46 (4.45–4.47); surface, especially L-shaped calli, shining; site of transverse impression and anterior half of posterior lobe with numerous, moderately coarse and fine punctures intermixed, these becoming obsolete toward posterior margin; anterior lobe with a subapical, transverse patch of crowded fine and a few coarse punctures, laterally with many crowded fine punctures; lateral submarginal setigerous punctures twenty-eight to thirty in number, their row very irregular anteriorly. **SCUTELLUM:** Length: width :: 2.13 (2.11–2.16) : 2.01 (2.01–2.02); surface shining, punctures coarser, deeper and slightly more dense than on mesocorium; apex acute with fine punctures. **HEMELYTRON:** Exclusive of membrane,

finely but distinctly alutaceous; costa with twelve or thirteen setigerous punctures; exocorium with numerous, very crowded, moderately coarse punctures; mesocorium more sparsely and irregularly punctate than exocorium, with two complete rows paralleling claval suture; with a faint but evident branching near middle of vein M; clavus with two complete and one interrupted row of punctures; membrane dirty milky white, extensively mottled with fuscous. MESO- and METAPLEURA: Quite similar to Figure 7. STERNITES: Weakly alutaceous, with numerous irregularly spaced aciculate punctures except along broad midline. LENGTH of body 6.11 (6.00-6.23).

TYPE DATA: The holotype female and a paratype of the same sex are in the British Museum and bear the label "C. T., 1.87, Distant Coll., 1911-383." The initials quite probably stand for Cape Town, SOUTH AFRICA, which is in the general region of occurrence of the other species of the genus.

DISCUSSION: The subapical pair of setigerous punctures on the clypeus coupled with the obsoletely punctate posterior half of hind pronotal lobe definitely allies this form to *natalensis* n. sp., of which this may be the female; however, since such strong divergence in vestiture of the two sexes of one species is not known in this part of the family, they are here considered to represent separate species.

The species name is given in reference to the type locality.

#### *Dearcla natalensis* new species

DIAGNOSIS: The presence of a submarginal row of setigerous punctures on each jugum coupled with the punctation of the scutellum being less dense than that of the mesocorium will separate the present species from the other two in the genus.

DESCRIPTION (based on lone male type). MALE.—HEAD: Length: width:: 1.14: 1.60; interocular width 0.94; surface with numerous moderately coarse, crowded punctures on jugs, with finer more scattered punctures on vertex and clypeus; jugum with six submarginal setigerous punctures; bucculae punctate, higher than labial II; antennae, I, 0.36, II, 0.45; III, 0.50; IV, 0.61; V, 0.66; labials, I, 0.56; II, 0.83; III, 0.70;

IV, 0.56. PRONOTUM: Length: width:: 2.00: 4.43; surface, especially L-shaped calli, shining, both lobes with numerous moderately coarse, crowded punctures; anterior lobe with subapical transverse patch of coarse and fine punctures intermixed and a few fine ones on midline between calli; site of transverse impression and anterior half of posterior lobe with numerous moderately coarse and fine punctures intermixed, these becoming much sparser posteriorly; lateral submarginal row of ten or eleven setigerous punctures. SCUTELLUM: Length: width:: 2.47: 2.15; surface shining, punctures coarser, deeper and distinctly sparser than those of mesorium: acute apex with crowded fine punctures. HEMELYTRON: Except for membrane, finely but distinctly alutaceous; with seven subcostal setigerous punctures; exocorium uniformly covered with moderately coarse, very crowded punctures; mesorium more sparsely and irregularly punctate than exocorium, with two complete rows of punctures paralleling claval suture, with a faint but evident branch arising near middle of vein M; clavus with two distinct rows and an irregular third row of punctures; membrane golden brown, extensively mottled with large fuscous blotches. MESO- and METAPLEURA: Quite similar to Fig. 7. STERNITES: Weakly alutaceous, with abundant aciculate punctures except along mid-ventral line. TERMINALIA: Male genital capsule with crowded fine, aciculate punctures; apical margin nearly straight; gonostylus very similar to that of *opercularis*. LENGTH of body: 7.12.

TYPE DATA: The holotype male in the British Museum of Natural History bears the label "NATAL, Weenen, X-XI, 1924, H. P. Thomasset."

DISCUSSION: See comments under preceding species.

#### *Dearcla opercularis* Signoret (Figs. 1-7)

1883 *Dearcla opercularis* Signoret, Ann. Soc. Ent. France, (6) 3: 364, pl. 9, fig. 190.

DIAGNOSIS: This species is recognizable within the genus by having the scutellar punctures distinctly denser than those of the mesorium.

DESCRIPTION (based on male type). MALE.—HEAD: Length:

width::0.86:1.36; interocular width, 0.90; surface with numerous, moderately coarse, crowded punctures on juga, with finer, more scattered punctures on clypeus and vertex; jugum with six or seven submarginal setigerous punctures; bucculae punctured, higher than labial II; antennals, I, 0.26; II, 0.40; III, 0.36; IV, 0.43; V, missing; labials, I, 0.46; II, 0.73; III, 0.60; IV, 0.46. PRONOTUM: Length:width::1.75:3.42; surface alutaceous, with numerous punctures crowded laterally; anterior lobe with subapical transverse patch of coarse and fine punctures intermixed and a few finer ones on midline between calli; hind lobe with numerous moderately coarse punctures and fine ones intermixed, these extending to the hind margin. SCUTELLUM: Length:width::2.00:1.95; surface weakly alutaceous, with numerous crowded punctures becoming finer apically. HEMELYTRON: Strongly alutaceous with not more than ten subcostal setigerous punctures (setae all missing and punctures confused); exocorium with densely crowded punctures becoming coarser basally; mesocorium less densely punctured than exocorium, with two complete rows of punctures paralleling the claval suture but no evidence of branching of vein M; clavus with three more or less complete rows of punctures; membranal suture weakly bisinuate, weakly produced laterally; membrane strongly embrowned. MESOPLEURON: (Fig. 7) evaporatorium extending to lateral margin along posterior edge; polished anterior part with several coarse punctures. METAPLEURON: Illustrated, Fig. 7. STERNITES: Strongly alutaceous, with coarsely aciculate punctures except along broad midventral line. TERMINALIA: Genital capsule alutaceous, its aciculate punctures not as dense as those towards sides of sternites, apical margin broadly and shallowly but distinctly concave; gonostylus as illustrated (Fig. 2). LENGTH of body 6.28.

TYPE DATA: Signoret's type male from "Simons Bay" in the west shore of False Bay south of Cape Town, Cape Province, Union of South Africa, is in the Naturhistorisches Museum, Vienna, Austria.

DISCUSSION: Study of the male type at the Naturhistorische Museum was made possible through the kindness of Dr. Max Beier to whom I am sincerely grateful.

***Dearcla paucivillosa* new species**

DIAGNOSIS: The lack of submarginal setigerous punctures on the head will separate *paucivillosa* from the other three species in the genus.

DESCRIPTION (based on single male type). MALE.—HEAD: Length: width: : 1.46: 2.07; interocular width, 1.25; surface shining, juga and vertex with numerous subcontiguous, moderately coarse punctures; jugum with but one submarginal setigerous puncture (the preocular); clypeus with scattered fine punctures and a few transverse rugae; bucculae punctate, about as high as labial II; antennals, I, 0.46; II, 0.63; III, 0.63; IV, 0.76; V, 0.86; labials, I, 0.91; II, 1.33; III, 1.26; IV, 0.78. PRONOTUM: Length: width: : 2.63: 4.62; surface, especially large L-shaped calli, shining; anterior lobe subapically with numerous moderately coarse and fine punctures intermixed; both lobes laterad of lateral limits of calli with numerous closely crowded moderate punctures; transverse impression and posterior lobe discally with numerous scattered, moderately coarse punctures interspersed with many minute punctures; lateral submarginal row of seven setigerous punctures (setae missing). SCUTELLUM (deformed by a transverse wrinkling which reduces its length, however, the longitudinal measurement is estimated on the base of where the tip might have been in relation to certain hemelytral developments): Length: width: : 3.27(?): 2.60; discally with numerous scattered, moderately coarse punctures interspersed with abundant minute punctures which are finer toward impunctate tip. HEMELYTRON: Corium alutaceous; costa straight and subparallel on basal half, with two or three submarginal setigerous punctures (setae mostly missing); exocorium from base to apex with closely crowded punctures; mesocorium discally with numerous punctures, these more widely spaced than those of exocorium, and with two complete rows of punctures paralleling claval suture, with a weak but evident branch arising near middle of vein M; clavus with three nearly complete rows of punctures; membranal suture bisinuate, lateral angle broadly prolonged; membrane longer than basal width,



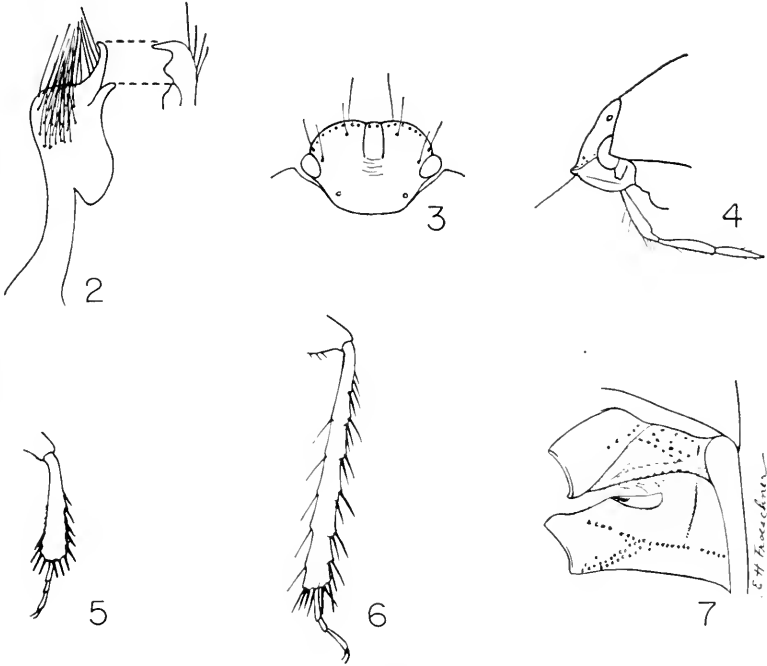

FIGS. 2-9. *Dearcla opercularis* Signoret.

golden tan with two fuscous blotches at base (outer one prolonged obliquely meso-posteriorly). MESO- and METAPLEURA: Similar to Figure 7. STERNITES: Strongly alutaceous, with closely aciculate punctures occupying all but broad midventral line. TERMINALIA: Genital capsule alutaceous, with numerous crowded punctures; midline transversely impressed at basal third; apical margin with shallow, broadly U-shaped median emargination and somewhat concave laterally; gonostylus quite similar to that of *opercularis*. LENGTH of body, 9.00.

TYPE DATA: The *holotype* male labelled "NATAL, Weenen, Mkolombe[?], N. C., 22.iii.1926, 5000 ft. H. P. Thomasset" is in the British Museum of Natural History, London.

## A New Species of Scorpion of the Vejovidae: *Paruroctonus vachoni*<sup>1</sup>

HERBERT L. STAHNKE,<sup>2</sup> Poisonous Animals Laboratory,  
Arizona State University, Tempe, Arizona

In its natural habitat, *Paruroctonus vachoni*, at first glance, may be mistaken for *Hadrurus arizonensis* (Ewing). This is largely due to the rather dark brown appearance of the mesosoma (preabdomen) and a carapace that has a somewhat light yellow interocular triangle followed by a darker posterior portion. Closer examination reveals a scorpion not nearly as hirsute, much more slender and with more prominently keeled pedipalp chela.

**HOLOTYPE.** An adult female, A.S. No. 61-1, taken December 4, 1960, by R. L. Swett, under a box in a tool shed at Sheep Creek Springs, elevation 1,800 ft, 37 miles north of Baker, California.

**ALLOTYPE:** An adult male, A.S. No. 60-488, collected November 21, 1960, in a kitchen sink at the same locality.

**PARATYPE:** A female, slightly shorter than holotype, A.S. No. 1663, collected by O. L. Wallace, September 9, 1955, in residence at Boulder City, Nevada. A large female, A.S. No. 1468.3, collected September 16, 1954, Trona, California, by Warren C. Vogt. Two large females, A.S. Nos. 894.3 and 1107.0, collected by Ann Pipkin, October 1948, in Wildrose Canyon, elevation 3,500 ft, Death Valley National Monument, California.

**DIAGNOSIS:** *P. vachoni* and *P. gracilior* are similar in coloration but the former shows more redness on pedipalp fingers. Since *P. mesaensis* lacks the brown coloration, the difference in this respect is quite distinctive. The telson vesicle of *P. vachoni* is more globular than that of either of the other two.

<sup>1</sup> Dr. Max Vachon, Director Laboratoire de Zoologie, Museum National d'Histoire Naturelle, Paris, France, has made very extensive contributions to the fields of scorpiology.

<sup>2</sup> Partially supported by the National Science Foundation.

The entire margin of the carapace of *P. vachoni* and *P. mesaensis* is straight while that of *P. gracilior* protrudes farthest at the mid-point. The following table will show other distinctive similarities and differences. Unfortunately, females of *P. gracilior* were not available; the data for the males are taken directly from the types of Hoffman.

TABLE 1.—Comparison of ratios in *P. vachoni*, *P. gracilior*, and *P. mesaensis*

	Pectinal Teeth	VEW/IW	HdW/HdTh	IL/IW
Males:				
<i>P. vachoni</i>	35/35	1.03	1.37	1.64
<i>P. gracilior</i>	26/26, 28/28	0.63-0.66	1.26-1.32	1.04-1.14
<i>P. mesaensis</i>	32/32, 38/39	0.69-0.74	1.24-1.32	1.37-1.42
Females:				
<i>P. vachoni</i>	24/24-27/27	0.76-0.96	1.25-1.47	1.29-1.41
<i>P. gracilior</i>	(not available)			
<i>P. mesaensis</i>	23/23-24/25	0.71-0.73	1.27-1.33	1.21-1.27

Abbreviations:

- VEW, Telson vesicle width  
 IW, Width caudal segment I  
 HdW, Chela hand width  
 HdTh, Chela hand thickness  
 IL, Length caudal segment I

DESCRIPTION OF THE HOLOTYPE:

*Carapace*: Background color light yellow with diffuse, brown pigment throughout. Anterior two-thirds of interocular triangle only lightly diffuse with dark pigment. Irregularly margined patches of brown lateral to the rather prominent blackish ocular tubercle. Sub-triangular brown spots posterior-median and posterior-lateral corners. Anterior margin straight, bearing about 6 bristles and forming pocket with anterior portion of the distinct median furrow which continues over the median ocular tubercle to form definite superciliary ridges. Very shallow immediately posterior to the tubercle but rapidly increases in depth until, half the distance to the well developed posterior furrow, it forms a deep, narrow furrow. Posterior lateral furrows very broad and shallow. Entire carapace with fine gran-

TABLE 2.—Dimensions in millimeters

	♀ Holotype	♂ Allotype
Pectinal teeth	24/24	35/35
Lengths:		
Total	71.1	85.5
Trunk	28.5	28.1
Cauda	42.6	57.4
Carapace	8.6	9.4
Preabdomen	20.3	18.7
Pedipalp*	29.2	35.7
Tibia	14.4	17.7
Patella	7.5	8.8
Femur	7.3	9.2
Leg IV		
Femur	9.5	11.4
Patella	6.8	7.4
Tarsomere I plus tibia	7.9	10.0
Widths:		
Cauda I	4.9	3.9
Cauda V	2.8	3.1
Telson vesicle	2.9	4.0
Carapace-posterior	8.0	8.3
Preabdomen IV	9.0	9.0

\* Minus coxa and trochanter.

ules interspaced freely with much larger granules. Three lateral eyes decreasing in size posteriorly; the smallest out of line with the other two. Frontal lobes moderately prominent.

MESOSOMA (*Preabdomen*). First six tergites entirely brown except for somewhat reticulated light areas laterad and two median ovoid light spots on each tergite. VII light yellow except for anterior median deposit of tan. All tergites densely covered with very fine granules and some larger ones, which increase progressively somewhat in size and number posteriad. Median keels vestigial on all segments but more so on anterior ones. VII also with two pair of lateral keels bearing large cone-shaped granules with similar granules in intercarinal spaces. Sternites I–VI agranular, sparsely hirsute, bearing elongate stigmata. VII with one pair lateral, granular keels and small granules in

intercarinal spaces. Pectines long and exceptionally slender; first teeth located one-third pectinal length; basal piece somewhat butterfly-shaped; anterior median notch extends approximately one-half-length. Genital plate not divided; broader than long; no genital papillae.

*METASOMA (Cauda)*: Very slender. All segments longer than wide. Vesicle not as wide as segments I-III.

1. Postabdomen: Uniform color, moderately hirsute.

*Dorsal keels* on I-IV well developed and bearing coarse, more or less uniform granules; on V weakly developed but bearing irregularly aligned granules that get increasingly smaller distad.

*Superior lateral keels*. Like dorsal keels but incomplete on V. Present on only 0.4 of proximal portion of segment bearing granules of moderate size.

*Median lateral keels*. Well developed and coarsely granular on I; vestiges on distal end of II and III; lacking on IV and V.

*Inferior lateral keels*. Well developed on all segments. Granules indistinct on II-V, getting progressively larger distad so that on V they are quite large and irregularly serrate.

*Inferior median keels*. Not prominent and with a few moderately large granules on I; greater keel development and larger granules progressively distad on remaining segments. V with one median keel bearing large cone-shaped granules.

*Anal arch*. Proximal ridge with irregularly placed large granules. Distal ridge agranular except for one large granule on extreme lateral end. A row of widely spaced long, coarse bristles in intermediate area.

*Intercarinal spaces*. All covered with very fine granules; on dorsal and dorso-lateral of segments I-III interspersed with few large granules which are lacking on IV and only sparsely found on V. Large granules almost entirely absent on ventral surface; a few large, distinct granules on V.

2. Telson. Elongate, smooth, bearing some inconspicuous broad granules and slightly hirsute. Two large bristles ventrally and medially at base of aculeus which bears its curvature in distal one-half. Lighter in color than rest of cauda.

*Appendages.* Of lighter color generally than rest of scorpion.

1. Chelicerae. Inferior border of movable finger with three or more truncated teeth of variable size and shape. Inferior border of fixed finger with three reddish tubercle-like protuberances. Movable finger bifurcate. Superior margins with four teeth; most distal two uniform size, about one-third length of third, fourth about same size as distal two.

2. Pedipalps. Uniform yellow color, fingers slightly reddish. Sparcely hirsute.

*Chelae.* Small granules on cutting edge of movable fingers non-serrate, arranged in longitudinal row and divided into six groups by six large denticulate granules; flanked internally by five large denticulate granules plus two terminal ones. Fixed finger with a total of six internal flanking granules. On both fingers, but more noticeable on movable fingers, a large bristle immediately posterior to each flanking granules except the two most distal ones. Cutting edges not noticeably scalloped. Hand keels well developed and granular. Lateral keels with larger, reddish granules. Inferior and superior intercarinal spaces largely agranular.

*PATELLA (Brachium):* All keels distinct and granular. Twenty trichobothria arranged as follows on posterior surface:

Most distal group	2
Diagonal distal group	4
Irregular medial group	8
Sub proximal group	4
Proximal group	2

A few large granules on proximal margin of anterior surface otherwise intercarinal spaces bear only minute granules.

*FEMUR (Humerus):* Superior keels well developed and bearing large granules. Intercarinal surface well covered with small granules. Inferio-anterior keels well developed and bearing large granules. Inferio-posterior keels vestigial and partially represented by moderately large granules.

3. Walking legs. Tarsal claws long; well developed median claw (unguicular spine); exterior and interior pedal spurs. Tibia and tarsomeres bear long, heavy bristles; longest and

greatest concentration on legs I to III and on tarsomeres I of these legs. Other leg joints sparsely hirsute. Median tarsal lobe triangular with one large bristle on apex and one on each corner of the base. Two bristles on distal edge of lateral lobes. Single row of short, thick spines on sole of tarsomere with two large bristles forming V distad and a cluster of small bristles proximad.

DESCRIPTION OF ALLOTYPE. Relatively shorter trunk; more coarsely granular and more elongate.

*Carapace.* Differs from female in that granules are larger and denser; not as much dark pigment which is confined largely to immediate lateral areas of ocular tubercle. Anterior margin, furrows and lateral eyes like female. Frontal lobes not as prominent but bear definitely larger granules.

MESOSOMA (*Preabdomen*): Reticulated light spots on first six tergites much larger than in female; the two median light ovoid spots lacking. Granulation similar to female but larger granules considerably more numerous on posterior portion of tergites. Median keels more developed than on female. Second pair of lateral keels on VII represented poorly. Sternites moderately hirsute bearing coarse bristles and densely covered with minute granules. VII with larger keels and granules than female. Pectines large, strongly hirsute with free margin of proximal middle lamella making a  $45^\circ$  angle with fulcral margin. Basal piece similar to female. Genital operculum divided; two conspicuous genital papillae.

METASOMA (*Cauda*): All segments more elongate than on female with vesicle noticeably broader and much lighter in color than segments.

1. Postabdomen. More hirsute than female, bearing coarse bristles.

*Dorsal keels.* Same as female.

*Superior lateral keels.* Like female except that on V it is present on proximal half of segment.

*Median lateral keels.* Same as female.

*Inferior lateral keels.* Prominent and definitely granular on all segments.

*Inferior median keels.* Bear small granules on I, agranular on II, somewhat granular on III; IV bearing irregularly aligned large granules and V with one well developed keel bearing serrate granules.

*Anal arch.* Same as female.

*Intercarinal spaces.* Same as female.

2. Telson. More globular and proportionately larger than on female. Otherwise similar.

*Appendages.* Light yellow except reddish tinge to fingers of chelicerae and pedipalps, and on the latter, the large granules of keels.

1. Chelicerae. Same as on female but tubercle-like protuberances on ventral surface of fixed finger may consist of one tooth-like protuberance flanked by clusters of smaller ones.

2. Pedipalps. Finger, redder and more hirsute than on female.

*Chelae.* Small and large granules of cutting edges like female but both fingers bear large lobes that fit into receiving depressions of opposing finger. The remaining distal portion of each finger mildly scalloped. Hand configuration like female except more strongly developed.

*Patella (brachium), femur (humerus) and walking legs* similar to female.

VARIATIONS. From the table of ratios it is obvious that females vary in pectinal tooth count from 24 to 27; that some females have pedipalp chelae as stout as those of the male is obvious. Also some females have a proportionately broader telson but none approach that of the male. Some females are more coarsely granular, have scalloped pedipalp finger cutting edges, have a varying amount of dark pigment from that of the holotype; but again, for these qualities they differ from the male. Unfortunately, no other males were available.

#### LITERATURE

- HOFFMAN, C. 1931. The Scorpiones de Mexico. *Anales del Inst. de Biol.* 2: 406-408.
- STAHNKE, H. L. 1957. A New Species of Scorpion of the Vejovidae: *Paruroctonus mesaenis*. *Ent. News* 68: 253-259.



## The Onychophora of Jamaica

ROSS H. ARNETT, JR., Department of Biology, The Catholic University of America, Washington, D. C.

The author has been privileged to study a fine lot of Onychophora from the island of Jamaica, representing several years of concentrated collecting by biologists associated with the Institute of Jamaica in Kingston. The results of this study are incorporated below. I wish to express my sincere appreciation to C. Bernard Lewis, Director of the Institute of Jamaica and Curator of the Science Museum, for giving me the opportunity to study this material. Mr. Lewis has collected much of this material himself, including the first specimens of the new species described below and which is dedicated to him. Grateful acknowledgment is also made of the notes and specimens furnished by Mr. R. P. Bengry, Assistant Curator at the Science Museum, and for his kind assistance in checking the manuscript and other details.

This group of animals, variously designated as a class of arthropods or lately, by an increasing number of zoologists, as a separate phylum, is of particular interest because of the zoogeographical implications it presents. The island of Jamaica now has four representatives, three species and one subspecies, as described below. Interestingly enough, each of these forms represents a different genus, of which one, *Plicatoperipatus*, is unique to the island. The other three genera are widely distributed throughout the West Indies, Central America, and northern South America. However, all of the forms herein reported are known only from Jamaica. The zoogeography of Onychophora has been discussed in numerous papers. These notes serve only as a supplement to those studies.

The colour of alcoholic specimens usually is destroyed or changed in such a way that it is difficult to use colour for identification. From notes furnished by Mr. Lewis and Mr. R. P. Bengry, it appears that in life the colour is relatively constant and is a help in recognizing species. These notes have been appended to the species descriptions that follow.

The key, illustrations, and descriptions will serve to identify the species known from Jamaica. The work of Bouvier (1905-7) and of Clark (1913) should be consulted for the definition of genera.

*Key to the Genera and Species of Onychophora of Jamaica*

1. 24 transverse dorsal folds to each segment, somewhat indistinct because of numerous anastomosing and irregularities in the grooves which separate them; 37-41 pairs of legs; papillae with acute apices and sub-apices, appearing serrate (Fig. 1); adults 40-55 mm long. . . . .  
*Plicatoperipatus jamaicensis* Grabh. & Ckll.
- 12 transverse dorsal folds to each segment, usually distinct; papillae various, but without the serrate appearance. . . . . 2
2. Primary papillae on the dorsal surface of the body each with a quadrangular base separated by straight grooves parallel with the axis of the body; accessory papillae ordinarily small and few in number; apices of primary papillae surmounted by a high and prominent truncated cone or slightly tapering cylinder (Fig. 2); 34-36 pairs of legs; adults 63-66 mm long. . . . .  
*Macroperipatus insularis clarki* subsp. nov.  
 Primary papillae of dorsal surface each with a more or less rounded base; accessory papillae exhibiting diverse stages of development . . . . . 3
3. Primary papillae of dorsal surface exhibiting great difference of size at all ages, generally arranged with three accessory papillae between two primary papillae; 29-33 pairs of legs; adults 43± mm long. . . . .  
*Peripatus swainsonae* Ckll.  
 Primary papillae of dorsal surface all of one type but of various sizes, with rounded or oval bases; primary papillae tall, with long, narrow, slightly tapering, cylindrical cones (Fig. 5); 34-36 pairs of legs; adults 71-79 mm (rarely 127 mm) long. . . . .  
*Epi-peripatus lewisi* sp. nov.

Genus **PLICATOPERIPATUS** Clark, 1913

*Plicatoperipatus jamaicensis* (Grabham and Cockerell, 1892).  
*Peripatus jamaicensis* Grabham and Cockerell, 1892, Nature 46: 514.

*Type locality*.—Jamaica, Beacon Hill, near Bath, 3 specimens.

This well-known species can be readily separated from all others by the unique arrangement of the dorsal folds of each

segment, there being 24 per segment instead of the usual 12. The papillae in lateral view are much more serrate than in other species and the apex lacks a noticeable cone (Fig. 1). This species is reported to be reddish brown in life, varying from maroon to vinous red. Most specimens have white-tipped antennae, but some are reported to be without this marking.

*Material studied.*—Portland, 5 miles southwest of Priestman's River (ca. 1,500 ft), Feb. 6, 1953, W. G. Lynn, collector, 3 specimens as follows: 37 pairs of legs, 55 mm long, 3 mm wide, 2.5 mm high; 38 pairs of legs, 18 mm long (young); 39 pairs of legs, 37 mm long, 4 mm wide, 2.5 mm high. About 1 mile W.S.W. of Ecclesdown (ca. 1,200 ft), March 30, 1958, R. P. Bengry, collector; 31 pairs of legs, 25 mm long, 3 mm wide, 2 mm high. Manchester. Summit of Heron's Hill (3,100 ft), March 3-8, 1952, from rotten log. G. R. Proctor, collector; 40 pairs of legs, 42 mm long. St. Thomas, 20 yards north of 6th milepost between Barrett's Gap and Corn Puss Gap (ca. 800 ft), July 25, 1952, under completely decayed tree-fern trunk, R. P. Bengry, collector; 40 pairs of legs, 40 mm long, 5 mm wide, 4 mm high. Morce's Gap (5,000 ft), July 21, 1936, W. G. Lynn, collector; 38 pairs of legs, 46 mm long, 2.5 mm wide, 2 mm high (deposited in the United States National Museum collection by the collector). Trelawny. Windsor (400 ft), Aug. 20, 1956, under stone, R. P. Bengry, collector; 38 pairs of legs, 60 mm long, 6 mm wide, 4 mm high. St. Ann. 2½ miles northwest of Hollymount (2,200 ft), May 24, 1957, under stone, R. P. Bengry, collector; 40 pairs of legs, 50 mm long, 5 mm wide, 4 mm high; 4.8 miles south of Moneague (2,750 ft), July 5, 1957, P. Drummond, collector; 36 pairs of legs, 35 mm long, 4 mm wide, 3 mm high. Mosely Hall Cave, near Blackstonedged (ca. 2,000 ft), Dec. 14, 1952, J. M. Valentine, collector; 37 pairs of legs, 28 mm long.

#### Genus **MACROPERIPATUS** Clark, 1913

##### **Macroperipatus insularis clarki**, subsp. nov.

*Type locality.*—Jamaica, Portland, 5 miles southwest of Priestman's River (ca. 1,500 ft).

The characteristics of *M. i. clarki* agree with Clark's description of the genus and of the typical *insularis* except that the cone of the primary papillae is narrower and more nearly cylindrical (Figs. 2 & 3) than in the type of the species (Fig. 3). In addition, *M. i. clarki* is larger (63–66 mm) and has more pairs of legs (34–36). *M. i. insularis* Clark is approximately 55 mm long with 30 pairs of legs. The colour of *M. i. clarki* is grey in life.

Four specimens are known, all from the same locality in Portland, 5 miles southwest of Priestman's River, ca. 1,500 ft. *Holotype*: Feb. 6, 1953, C. B. Lewis, collector; 36 pairs of legs, 65 mm long, 4.5 mm wide, 3 mm high. *Paratype*: Feb. 6, 1953, C. B. Lewis, collector; 34 pairs of legs, 63 mm long, 5 mm wide, 3.5 mm high. *Paratype*: March 11, 1953, W. G. Lynn, collector; 35 pairs of legs, 66 mm long, 4 mm wide, 3 mm high. *Paratype*: March 11, 1953, W. G. Lynn, collector; 36 pairs of legs, 63 mm long, 4 mm wide, 2.5 mm high.

It is interesting to note that the nearest relative of this species is from Veracruz, Mexico (*Macroperipatus parrieri* Bouvier); no Onychophora are yet known from Cuba. *M. i. insularis* Clark, the type of the species, was collected between Jacmel and Tronim, Haiti.

### Genus PERIPATUS Guilding, 1826

*Peripatus swainsonae* Cockerell, 1893.

*Peripatus juliformis* var. *swainsonae* Cockerell, 1893, Zoologische Anzeiger, 16: 341.

*Type locality*.—"Jamaica."

This species may be recognized on the basis of its generic characteristics alone, principally by the arrangement of the primary and accessory papillae as given in the key. It is the smallest of the four species and has the least number of legs. The shape of the papillae distinguishes it from all other species on the island: It has a broad base which tapers gradually to a broad summit; the cone is short and broad (Fig. 4). This species is reported to be olive-green in life.

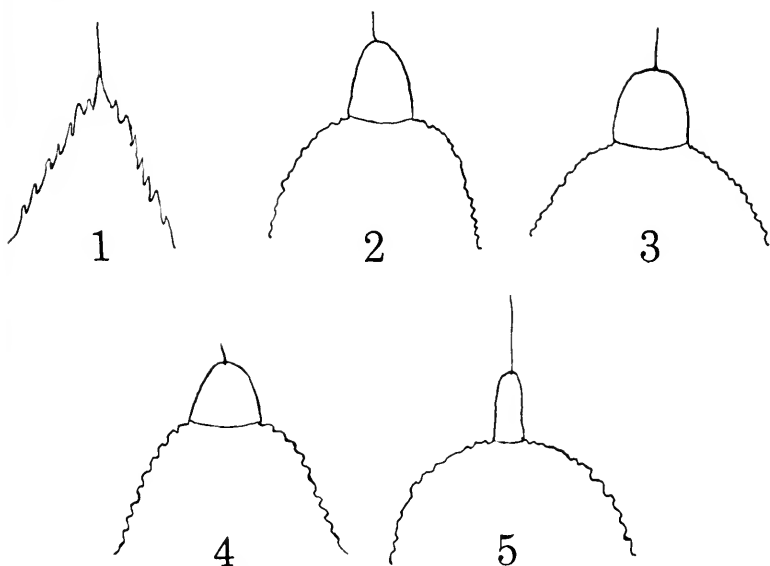

Lateral view of the primary papillae of adults.

- FIG. 1. *Plicatoperipatus jamaicensis* Grabham and Cockerell.  
 FIG. 2. *Macroperipatus insularis* subspecies *clarki*, new subsp.  
 FIG. 3. *Macroperipatus insularis* subspecies *insularis* Clark.  
 FIG. 4. *Peripatus swainsoni* Cockerell.  
 FIG. 5. *Epiperipatus lewisi*, new species.

*Material studied.*—Hanover. Lances Bay, September 13, 1952, collected under stone, on limestone, 2½ inches of rain on previous day, W. G. Lynn, collector; 30 pairs of legs, 43 mm long, 4 mm wide, 3 mm high. Portland. 5 miles southwest of Priestman's River, ca. 1,500 ft, March 11, 1953, W. G. Lynn, collector; 31 pairs of legs, 22 mm long. Trelawny. Windsor (400 ft), Aug. 20, 1956, under stone, R. P. Bengry, collector; 28 pairs of legs, 22 mm long, 4 mm wide, 3 mm high.

There are also five young specimens, born in the laboratory, which appear to belong to this species. However, it is not apparent to the author which specimens were the parents of these immatures. The plication and papillae are not sufficiently developed at birth to make certain of the identification. The

number of legs on these young specimens seems to indicate that they belong to this species.

Genus **EPIPERIPATUS** Clark, 1913

**Epiperipatus lewisi** sp. nov.

*Type locality*.—Jamaica, Portland, John Crow Mountains, ca. 10 miles southwest Priestman's River.

This is the largest species known on the island, the average length being about 75 mm. In addition to the characteristics for the genus, the following features are noted. The primary papillae are irregular in size with numerous accessory papillae. The cone of the papilla is long, narrow, slightly tapering, cylindrical (Fig. 5). The urinary papillae are located on the fourth and fifth pair of legs. The fourth arc is arched beneath the urinary papilla, but not divided into segments; the urinary papilla is attached to the third arc by a broad band. The legs vary from 34 to 36 pairs. In life, this species is grey to rich dark reddish-brown.

Three specimens of this new species were recently collected by Mr. R. P. Bengry, who supplies the following interesting notes: The specimens were collected in a rotten log on a rocky slope. The largest specimen (which is probably the largest *Peripatus* known, measuring 127 mm in life) was collected first. "Careful examination of the well-decayed log debris, torn apart largely by hand, revealed another two of the same kind (*E. lewisi*) and a small different one, (*P. jamaicensis*). I am of the distinct opinion that the first found specimen was very light reddish (almost pink flesh coloured) but I did not see it change colour (if it did) and the other two were not so light coloured when found. . . . The colour as we observed them is in our opinion: rich, dark reddish-brown with a soft (not shiny) velvety appearance. We noted that they walk in reverse with just as much ease as forwards and also that when poked with a finger wriggle 3 or 4 times in the manner of an earthworm. We searched in logs, under stones and leaf mould for more but found none. It is interesting to note that there were few, if any, tree-ferns where we were working."

The closest relative of this species is *E. edwardsii* (Blanchard) from Panama. It may be readily separated from that species by the large size, the broad connection of the urinary papillae with the third arc, and the long, narrow cones of the papillae, as contrasted to the short, broad cones of *E. edwardsii*.

The following six specimens are designated as holotype and paratypes. *Holotype*: Portland, John Crow Mountains, ca. 10 miles southwest of Priestman's River, Jan. 9, 1951, C. B. Lewis, collector; 35 pairs of legs, 75 mm long, 6 mm wide, 4 mm high, deposited in the United States National Museum collection. *Paratypes*: same locality and date as holotype, C. B. Lewis, collector; two paratypes as follows: 34 pairs of legs, 75 mm long, 6 mm wide, 3.5 mm high; 36 pairs of legs, 71 mm long, 6 mm wide, 3.5 mm high. Portland. 5 miles southwest of Priestman's River (ca. 1,500 ft), Feb. 6, 1953, W. G. Lynn and C. B. Lewis, collectors, three paratypes as follows: 35 pairs of legs, 55 mm long, 5 mm wide, 3 mm high (killed March 4, 1953, and oviducts removed for sectioning); 35 pairs of legs, 72 mm long, 6 mm wide, 5 mm high; 35 pairs of legs, 79 mm long, 6 mm wide, 5 mm high.

Additional material examined. Portland. ca. 1 mile W.S.W. of Ecclesdown, March 30, 1958, R. P. Bengry, collector, three specimens as follows: 36 pairs of legs, 127 (living specimens), 112 (preserved specimens) mm long, 10 mm wide, 7 mm high; 35 pairs of legs, 78 mm long, 7 mm wide, 5 mm high; 36 pairs of legs, 76 mm long, 7 mm wide, 5 mm high.

No other species of *Epiperipatus* is known from the West Indies proper, except for *E. barbouri* Brues from Grenada. *E. trinidadensis* (Stuhlmann) is known from Trinidad and *E. t.* var. *broadwayi* Clark is described from Tobago. I have recently identified *E. edwardsii* from Trinidad.

#### BIBLIOGRAPHY

- ANDREWS, E. A. 1911. Johns Hopkins Univ. Circ., Feb. 1911, pp. 1-4.  
— 1933. Quart. Rev. Biol. 8: 155-163.  
BARBOUR, T. 1910. Bull. Mus. Comp. Zool. 52: 271-301.  
BENGRY, R. P. 1953. Nat. Hist. Notes, Nat. Hist. Soc. Jamaica 5(58): 167.

- BOUVIER, M. E. L. 1905. *Ann. Sci. Nat. Zool.* ser. 9, 2: 1-383.  
— . 1907. *Loc. cit.* 5: 61-318.  
BRUES, C. T. 1911. *Bull. Mus. Comp. Zool.* 54(8): 305-318.  
CLARK, A. H. 1913. *Proc. Biol. Soc. Washington* 26: 15-20.  
COCKERELL, T. D. A. 1893. *Zool. Anz.* 16: 341-343.  
— . 1901. *Nature* 63: 325-326.  
DUERDEN, J. E. 1901. *Nature* 63: 440-441.  
GOSSE, P. H. 1851. *A Naturalist's Sojourn in Jamaica.* London.  
GRABHAM, M. and T. D. A. COCKERELL. 1892. *Nature* 46: 514.  
GRABHAM, M. 1893. *Journ. Inst. Jamaica* 1: 217-220.  
GUILDING, L. 1826. *Zoological Journal* 2: 443.  
LYNN, W. G. 1944. *Nat. Hist. Notes, Nat. Hist. Soc. Jamaica* 2(19): 113-114.  
— . 1946. *Glimpses of Jamaican Natural History* 2: 21-23.  
SEDWICK, A. 1888. *Quart. Journ. Micro. Soc.* 28: 431-493.  
WALTER, M. 1943. *Nat. Hist. Notes, Nat. Hist. Soc. Jamaica* 1(9): 10-11.
- 

## Nomenclature Notice

All comments relating to the following should be marked with the Commission's File Number and sent in duplicate, before December 16th, to the Secretary, International Commission on Zoological Nomenclature, c/o British Museum (Natural History), Cromwell Road, London, S.W. 7, England.

- Validation of the generic name **Cicadella** Latreille, 1817 (Order Hemiptera). Z.N. (S.) 457.  
Designation of a type-species for **Conomelus** Fieber, 1866 (Order Hemiptera). Z.N. (S.) 468.  
Designation of a type-species for **Aphis** Linnaeus, 1758 (Order Hemiptera). Z.N. (S.) 881.  
Designation of a type-species for **Dasiops** Rodani, 1856 (Order Diptera). Z.N. (S.) 1240.  
Designation of a type-species for **Harrisoniella** Bedford, 1928 (Order Mallophaga). Z.N. (S.) 1282.  
Designation of a type-species for **Lestis** Lapeletier & Serville, 1828 (Order Hymenoptera). Z.N. (S.) 1383.

For details see *Bull. Zool. Nomencl.* Vol. 18, Part 3.



## Reviews

FACTS AND THEORIES CONCERNING THE INSECT HEAD. By R. E. Snodgrass. Smithsonian Miscellaneous Collections, Vol. 142, No. 1. Pp. 1-56. Smithsonian Institution, Washington, D. C., 1961.

This compendious little booklet, like all of Dr. Snodgrass's work, is characterized by its succinct yet smooth and lucid language; each idea is approached most directly and set forth clearly without an excess word or phrase. The discussions of complex anatomical details are easily followed, and as for the theoretical part, this is even delectable, for theories are often more fun than facts.

Dr. Snodgrass likes to relate his thinking to the broadest fundamental concepts, and so, on page one along with a statement of the scope of the book there is this precis on morphology and its relation to anatomy and ontogeny:

"Morphology is an attempt to understand the significance of anatomical facts in relation to one another, and to reconstruct from the known facts the evolutionary development by which the animal has come to be what it is today. Consequently as new facts come to light our morphology has to be revised to fit them, though it sometimes seems as if some morphologists find it easier to make the facts fit their theories. Ontogeny and anatomy are visible facts not always correctly observed; morphology and phylogeny are mental concepts that cannot be demonstrated."

Chapter I (8 pages) treats of the development and evolution of the head capsule and its appendages. The chief conclusion is that the head is constituted of a preoral region (head lobes or blastocephalon of the embryo) that bears the eyes and antennae, and of a postoral region of four undoubted segments,

the premandibular (tritocerebral) and the three appendage-bearing segments. This idea is already set forth in Snodgrass's *Principles of Morphology* (1935) but is here more perfectly developed.

Chapters II-VI (28 pages) deal with the morphology of the head capsule and its appendages. The emphasis is on understanding its component structures in arthropods and their evolution in the Insecta. Almost 100 drawings illustrate this section.

Chapter VII, entitled "Theoretical Considerations," takes up the various theories of the segmental origin of the insect head, the old ones that are still actively supported as well as some novel ones of recent origin. Curiously, the same "facts" are often used to support very different ideas, and as Snodgrass remarks: ". . . the facts often seem less important than the theoretical discussions about them." Mostly it is claimed that the preoral part of the head is made up of three segments, or even four, but not necessarily in the same order. Thus, one theory states that the labrum represents Segment I, another that it is really what is usually numbered Segment III (tritocerebral), and both base their conclusions on the same "facts" of innervation! Dr. Snodgrass gives an amazingly compact yet perspicuous account of the crucial observational data and the reasoning upon which the alternative theories are based. Many misinterpretations of facts are exposed and fallacious reasoning is confuted from his own more thorough knowledge of arthropod morphology. Always concerned primarily with investigating anatomical facts and developing a sound morphology, he now also brings in the theory that he himself has favored, albeit with a characteristic fine restraint. He suggests that as long as there is no real evidence that the preoral head region was ever segmented we

"may as well in the meantime be content with the facts as they are known. If we must have a theory, that of the prostomial nature of the embryonic blastocephalon is the simplest and easiest to visualize.

And he goes on to remark:

“And really, it would be too bad if the question of head segmentation ever should be finally settled; it has been for so long such fertile ground for theorizing that arthropodists would miss it as a field for mental exercise.

R. G. SCHMIEDER

CICINDELIDAE OF CANADA by J. B. Wallis. Pp. xiv + 74, 5 plates (4 colored), 16 maps. University of Toronto Press, 1961. Price, bd., \$5.00.

This study includes two species of *Omus* and 26 of *Cicindela*, and a total, if subspecies are counted, of 49 named forms. A brief account of the life history and habits of tiger-beetles is followed by keys and the data on individual species and subspecies. The color plates show 106 beetles, including all the named forms and many of the color variants.—R. G. SCHMIEDER.

WESTERN BUTTERFLIES by Arthur C. Smith. Illustrated by Gene M. Christman. A Sunset Junior Book. Pp. 65, 8" × 9". Lane Book Co., Menlo Park, California, 1961. Price, bd., \$2.95.

This is a bright and handsome book with about three-quarters of the 127 species illustrated, mostly by paintings in color on habitat backgrounds. Often both sexes are shown and both wing surfaces. Interestingly written in simple language not too difficult for a ten year old, it tells about butterflies—their lives, habits, kinds—and gives suggestions on butterfly hobbies (collecting and rearing). The species are described under eleven different habitats from city yards to mountain tops. There is also a list which, under family headings, gives the common and scientific names, ranges, food plants, and page references.—R. G. SCHMIEDER.

# Entomologist's Market Place

## ADVERTISEMENTS AND EXCHANGES

Advertisements of goods or services for sale are accepted at \$1.00 per line, payable in advance to the editor.

Notices of wants and exchanges not exceeding three lines are free to subscribers.

All insertions are continued from month to month, the new ones are added at the end of the column, and, when necessary, the older ones at the top are discontinued.

---

**Butterflies.** Wish to exchange specimens for Japanese species. Please write to Ichiro Nakamura (Boy, age 16), 26 Aza-Nichiyama Obayashi Takarazuka-shi, Hyogo-Ken, Japan.

**Phasmidae** of nearctic area desired alive. Purchase or trade, drawing on large stock of major orders, worldwide. Domminck J. Pirone, Dept. Entomology, Cornell University, Ithaca, N. Y.

**Nitidulidae and Rhizophagidae** wanted in exchange for European beetles of all families. O. Marek, Zámberk 797, Czechoslovakia.

**Wanted and Needed.** We are compiling a history of entomology, and particularly, at present, of the amateur insect clubs that flourished 50 to 75 years ago. Will you who have knowledge of such early clubs or societies advise me, giving facts on the time of existence, members, etc., which you may have. J. J. Davis, Dept. of Entomology, Purdue University, Lafayette, Indiana.

**Cockroaches (Blattoidea)** of Japan, Okinawa, Formosa (Taiwan), and the Philippines are being studied in cooperation with Dr. K. Princis. Loans of specimens from that area are desired. A. B. Gurney, U. S. National Museum, Washington 25, D. C.

**Orthoptera. Gryllinae** (except domestic sp.) and **Pyrgomorphinae** of the world wanted in any quantity for work in morphology, taxonomy, cytology, and experimental biology; dry, or in fluid, or living. Write D. K. Kevan and R. S. Bigelow, Dept. of Entomology, McGill University, Macdonald College, Quebec, Canada.

**Beetles** of the world wanted, all species in exchange for American beetles, moths and butterflies. James K. Lawton (age 18), 7118 Grand Parkway, Wauwatosa 13, Wisconsin.

**Used genuine Schmidt boxes**, excellent condition, at less than half price. H. W. Allen, Box 150, Moorestown, N. J.

# Important Mosquito Works

**MOSQUITO ATLAS. Part I. The Nearctic Anopheles, important malarial vectors of the Americas, and *Aedes aegypti* and *Culex quinquefasciata***

**MOSQUITO ATLAS. Part II. The more important malaria vectors of the Old World: Europe, Asia, Africa and South Pacific region**

By Edward S. Ross and H. Radclyffe Roberts

Price, 60 cents each (U. S. Currency) with order, postpaid within the United States; 65 cents, foreign.

---

## KEYS TO THE ANOPHELINE MOSQUITOES OF THE WORLD

With notes on their Identification, Distribution, Biology and Relation to Malaria. By Paul F. Russell, Lloyd E. Rozeboom and Alan Stone

Mailed on receipt of price, \$2.00 U. S. Currency. Foreign Delivery \$2.10.

---

For sale by the American Entomological Society, 1900 Race Street, Philadelphia 3, Pa., U. S. A.

---

## Just Published

### New Classified Price Lists

Available separates from the TRANSACTIONS OF THE AMERICAN ENTOMOLOGICAL SOCIETY and ENTOMOLOGICAL NEWS, and all titles of the Society's MEMOIRS have been catalogued by author in twelve special price lists in the following categories:

Coleoptera  
Diptera  
Hemiptera  
Hymenoptera  
Lepidoptera  
Memoirs

Neuroptera and Smaller Orders  
Odonata  
Orthoptera-Dermaptera  
Arachnida and Other Classes  
Bibliography-Biography  
General

Lists will be mailed free upon request. Please state specifically which list or lists you require.

**The American Entomological Society**

1900 RACE STREET

PHILADELPHIA 3, PENNSYLVANIA

Just Published

**MEMOIRS OF THE AMERICAN  
ENTOMOLOGICAL SOCIETY**

Number 17

**A TAXONOMIC STUDY OF THE  
MILLIPED FAMILY SPIROBOLIDAE  
(DIPLOPODA: SPIROBOLIDA)**

By William T. Keeton

147 pages of text, 37 tables, 2 maps, 18 plates,  
table of contents and index

Spirobolid millipeds are probably the most widely known Diplopoda in the United States, being used in many college courses; yet the family has been little studied. This monograph brings together existing knowledge of the group for the first time, and adds much new information gained from critical study of series. The taxonomic history of the family is outlined. External morphology is briefly treated, with emphasis on characters utilized in classification. A summary of current knowledge of life histories is included. The family is redefined, and each genus and species is treated in detail. Particular attention is given to variation and distribution, both of which become more meaningful biologically as a result of synonymizing many species names. Possible phylogenetic relationships of the genera are discussed, and keys to all taxa are provided, with most diagnostic characters illustrated in 18 plates or summarized in 37 tables.

Price \$5.50

---

**THE AMERICAN ENTOMOLOGICAL  
SOCIETY**

1900 Race Street, Philadelphia 3, Penna., U.S.A.

Insects.

Subscriptions for 1962 Are Now Due

*Subscription Blank Enclosed*

# ENTOMOLOGICAL NEWS

**NOVEMBER 1961**

Vol. LXXII

No. 9

---

**CONTENTS**

Evans—Nesting behavior of <i>Plenoculus davisii</i> .....	225
Sabrosky—Three new nearctic acalyptrate Diptera.....	229
Alexander—New exotic crane-flies. Part IV.....	235
Scott—Genitalic key to U. S. genera of mosquitoes.....	243
Coppel—Unusual habitat for <i>Ancistrocerus tigris</i> .....	246
Wray and Knowlton—Collembola from rodent nests.....	248
Obituary .....	251

---

PUBLISHED MONTHLY, EXCEPT AUGUST AND SEPTEMBER, BY  
THE AMERICAN ENTOMOLOGICAL SOCIETY  
PRINCE AND LEMON STS., LANCASTER, PA.  
AND  
1900 RACE STREET, PHILADELPHIA 3, PA.

---

Subscription, per yearly volume of ten numbers: \$5.00 domestic; \$5.30 foreign; \$5.15 Canada.  
Second-class postage paid at Lancaster, Pa.

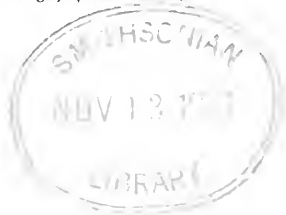

ENT. NEWS  
S.S. MAIL

# ENTOMOLOGICAL NEWS

---

**ENTOMOLOGICAL NEWS** is published monthly, excepting August and September, by The American Entomological Society at Prince and Lemon Sts., Lancaster, Pa., and the Academy of Natural Sciences, 1900 Race Street, Philadelphia 3, Pa., U. S. A.

**PHILIP P. CALVERT**, Editor Emeritus. **R. G. SCHMIEDER**, Editor. Editorial Staff: **H. J. GRANT, JR.**, **E. J. F. MARX**, **M. E. PHILLIPS**, and **J. A. G. REHN**.

**SUBSCRIPTIONS:** Communications and remittances to be addressed to **Entomological News, 1900 Race Street, Philadelphia 3, Pa.**

Prices per yearly volume of 10 numbers.

Private subscriptions, for personal use: in the United States, \$5.00; Canada, \$5.15; other countries, \$5.30.

Institutional subscriptions, for libraries, laboratories, etc.: in the United States, \$6.00; Canada, \$6.15; other countries, \$6.30.

**ADVERTISEMENTS:** Rate schedules available from the editor.

**MANUSCRIPTS** and all communications concerning same should be addressed to **R. G. Schmieder, Zoological Laboratory, University of Pennsylvania, Philadelphia 4, Pa.**

The receipt of all papers will be acknowledged and, if accepted, they will be published as soon as possible. Articles longer than eight printed pages may be published in two or more installments, unless the author is willing to pay the cost of a sufficient number of additional pages in any one issue to enable such an article to appear without division.

**ILLUSTRATIONS:** Authors will be charged as follows: For text-figures, the cost of engraving; for insert plates (on glossy stock), the cost of engraving plus printing. Size limit, when printed, 4×6 inches. All blocks will be sent to authors after printing.

**TABLES:** The cost of setting tables will be charged to authors.

**SEPARATA:** Members of the American Entomological Society may elect to receive, gratis, 25 offprints of their contributions. These will be "run-off-form," without removal of extraneous matter.

Those members desiring more than 25 separates, and all non-members, will receive no gratis copies. They must obtain all their separates (as reprints, with extraneous matter removed) from the printer at the prices quoted below. Authors must place their order for such separates with the editor at the time of submitting manuscripts, or when returning proof.

Copies	1-4 pp.	5-8 pp.	9-12 pp.	Covers
50	\$4.35	\$6.96	\$10.88	\$4.74
100	5.21	8.26	13.05	6.48
Add'l 100	1.74	2.60	4.33	3.48

Plates printed one side: First 50, \$3.47; Additional 100's, \$2.61.

Transportation charges will be extra.



N.B.—Subscriptions are due in advance. The January 1962 and following numbers will not be mailed to you unless your 1962 subscription has been paid.

## SUBSCRIPTION BLANK 1962

Enclosed please find a remittance of \$..... for the ENTOMOLOGICAL NEWS for one year, beginning with the issue of January 1962.

Name .....

Address .....

### PRIVATE SUBSCRIPTIONS, FOR PERSONAL USE

Subscription price per year of 10 numbers postpaid throughout the World.....\$6.00

To paid up resident members of The American Entomological Society.....\$3.00

### INSTITUTIONAL SUBSCRIPTIONS, FOR LIBRARIES, LABORATORIES, ETC.

Subscription price per year of 10 numbers postpaid throughout the World.....\$9.00

Subscriptions begin with January issue

Please make all remittances payable to ENTOMOLOGICAL NEWS in U. S. Dollars, by Currency (at sender's risk), checks on domestic (U. S.) banks, drafts on New York or Philadelphia, U. S. Postal, American Express or International Postal Money-orders.

Address:

THE AMERICAN ENTOMOLOGICAL SOCIETY  
1900 RACE ST., PHILADELPHIA 3, PA.



# ENTOMOLOGICAL NEWS

---

---

VOL. LXXII

NOVEMBER, 1961

No. 9

---

---

## Notes on the Nesting Behavior of *Plenoculus davisii* Fox (Hymenoptera: Sphecidae)

HOWARD E. EVANS, Museum of Comparative Zoology,  
Cambridge, Mass.

The genus *Plenoculus* includes some of our smallest digger wasps, females usually measuring about five or six millimeters in length. In a recent revision of the genus, Williams (1960) has reviewed what is known of the biology of members of the genus. Of the fifteen North American species, two are known to prey upon Hemiptera (*davisii*, *stygius*), while a third (*cockerellii*) apparently preys upon pyralid caterpillars. Nothing is known regarding the other twelve species. Williams' (1914) report on *apicalis* (= *d. davisii*) contains the only available information on nest structure and provisioning behavior, but this report leaves several questions unanswered.

My acquaintance with this genus is limited to the most common and widely distributed form, *d. davisii* Fox. A few years ago I attempted to collect larvae of this form for inclusion in a survey of the structure of sphecid larvae. After several failures, I finally obtained one full-grown larva which has since been described (Evans 1959). The notes gathered in the course of these studies appear to add several details to what is known of the behavior of the species and are therefore summarized here. One field note was made in Grant Co., Kansas, in August 1952, two at Ithaca, N. Y., July and August 1953 and 1957, and six others at Granby Center, Oswego Co., N. Y., June-August 1955-58. I am indebted to F. X. Williams for identifying the *Plenoculus* and to D. M. Weisman for determining the hemipterous prey.

*Plenoculus d. davisi* nests in small sand pits, blow-outs, washes, and other places where there is flat or slightly sloping open sand or sandy gravel. Usually I have found only one or two at a time, but at Granby Center there were many females nesting, though the nests were widely scattered over the available sand. Nests are ordinarily dug in the morning, provisioned throughout the day, then closed in the late afternoon. About two hours of intermittent digging are required to complete a nest. The female kicks sand vigorously with the front legs while the abdomen moves up and down rapidly in synchrony with the front legs. Once finished, the nest is left open at all times until provisioning is complete. The small mound of sand that accumulates at the entrance remains intact until time of the final closure.

Several nests dug out at Granby Center, N. Y., entered the ground at about a 30–45 degree angle with the surface, then after 1–2 cm became vertical or nearly so, terminating in a cell at a depth of 4–7 cm. In the one nest dug out at Ithaca, the burrow was straight, forming about a 60 degree angle with the surface; the burrow was 7 cm long and terminated in a cell at a vertical depth of 5.5 cm. All of these nests had but a single cell. However, my studies were not sufficiently detailed so that I could be sure that unicellular nests are always the rule in these areas. All successful excavations were made before the nests had received the final closure, as it proved very difficult to dig out these very small nests once the burrow had been filled with sand. The diameter of the burrow was only about 1.5 mm, the cells only about 4 mm in diameter.

The one nest dug out in Grant Co., Kansas, had an oblique burrow which formed about a 45 degree angle with the surface; it was about 5 cm long, at a depth of 3.5 cm terminating in a cell. Beyond this cell I found three additional cells in more or less a straight line, all about 5 cm below the surface and from 1 to 2.5 cm apart. The burrow connecting these cells had been filled, but the burrow leading from the surface to the newest cell was still open. The female had been seen digging this nest in the morning; when it was dug out at 5 P.M. the three

completed cells each contained an egg. Williams (1914) found several cells per nest in Phillips Co., Kansas. In this case some of the cells contained partially grown larvae, indicating that the wasp had remained with the same nest over a period of several days.

TABLE 1.—Contents of nests of *Plenoculus d. davisi*

Nest no.	Locality	<i>Lygus lineolaris</i> nymphs	<i>Lygus lineolaris</i> adults	<i>Chlamydatus associatus</i> adults	<i>Trigonotylus ruficornis</i> adults
107, cell 1	Grant Co., Kansas	3			
107, cell 2		5			
107, cell 3		3			
107, cell 4		4			
592	Ithaca, N. Y.	2	1		
1552	Oswego Co., N. Y.	1	2		
1580A	Oswego Co., N. Y.	5		2	
1580B	Oswego Co., N. Y.	3	2		
1580C	Oswego Co., N. Y.				8

Williams found the nests to be provisioned with a single species of Miridae (probably *Psallus seriatus* Reuter), both adults and immatures. However, he cites one record of a burrow provisioned with immature aphids (Williams 1960). In the three localities in which I studied this wasp, Miridae were used exclusively, both adults and immatures. Any one nest tended to be provisioned with only one species, but there were some exceptions. In all, four quite different-looking mirids were employed. These were: *Lygus lineolaris* (P. de B.), *Phytocoris quercicola* Knight, *Trigonotylus ruficornis* (Goeffroy), and *Chlamydatus associatus* (Uhler). From three to eight bugs were used per cell (see accompanying table). In addition to those bugs taken from cells and recorded in the table, several more specimens of *Lygus lineolaris* and one specimen of *Phytocoris quercicola* were taken from wasps captured on the wing.

The bugs are carried to the nest in flight, the wasp grasping the beak of the bug very firmly in the mandibles (the wasps often retain their grasp on the bug even after being killed in cyanide). In flight, the bug is also embraced by the legs of the wasp; the bug is always venter-up. The wasp may land one

or more times on the sand with the prey before arriving at the open nest entrance and plunging quickly in. Bugs may be brought in rather rapidly, one every few minutes, or at much more widely spaced intervals; in any case the wasp usually remains inside the nest only a few seconds.

In the cell, the bugs are placed venter-up, head-in. Oviposition does not occur until the last bug is in place. The egg is whitish, about 1.5 mm long, curved only slightly. It is laid on the venter of the top bug, one end glued to the body just in front of one of the middle coxae, the rest of the egg extending free, off to one side at a right angle to the long axis of the bug. The egg hatches in two days and the larva begins feeding through the coxal cavity, its body at first remaining more or less perpendicular to that of the bug. Williams (1914, fig. 120) figures the small larva feeding, and my observations confirm his on this point. The one larva that was brought to maturity in a rearing tin required seven days from the time of hatching.

Collecting and nesting records from both New York and Kansas indicate that this wasp has at least two generations a year in both areas. There remain several unsatisfactorily resolved problems regarding this species. In particular, more information is needed on the number of cells per nest and whether or not the female makes a new nest every day or may add cells to an old one. Since Williams experienced some difficulty in excavating his nests, it is not absolutely certain that the cell which he found containing a feeding larva actually belonged to the nest he was digging. *Plenoculus davisii* is a difficult wasp to work with, chiefly because of its small size and the ease with which the inconspicuous nests can be accidentally destroyed.

#### REFERENCES CITED

- EVANS, H. E. 1959. Trans. Amer. Ent. Soc. 85: 166-167, pl. XXIII.  
WILLIAMS, F. X. 1914. Kansas Univ. Sci. Bull. 8: 207-208.  
———. 1960. Proc. Calif. Acad. Sci. 31: 1-49.

### Three New Nearctic Acalypterate Diptera

CURTIS W. SABROSKY, Entomology Research Division, Agricultural Research Service, United States Department of Agriculture, Washington, D. C.

Frequently, a revision of a genus of insects is hardly published before undescribed species are discovered. Three such species are described here, with notes placing them in the recently published keys. Two are in the family Milichiidae, and one in Trixoscelidae.

#### MILICHIIDAE

##### **Meoneura californica**, new species

Highly polished black, with yellow halter knob, lightly browned wing, and two pairs of dorsocentral bristles.

Male.—Predominantly black; anterior half of front reddish yellow, parafacial and cheek anteriorly reddish brown; knob of halter lemon-yellow, the stalk brown; veins brown, the wing membrane lightly brown tinted.

Front shining, the frontal triangle poorly distinguished, especially toward apex, not smooth and polished as in *M. polita* Sabrosky, half as long as the front and with similar minute wrinkling; ocellar tubercle obscurely gray pollinose, subshining; eye large, rounded; cheek shining but not smooth, minutely wrinkled both above and below the diagonal ridge, rather broad, height at the middle 0.44 times that of an eye; middle bristle of the three on the vibrissal angle slightly shorter than the others; chaetotaxy of head as usual in the genus, the bristles moderately strong; postvertical bristles slightly divergent; one pair of anterior interfrontal bristles fairly strong and distinct, directed forward above the lunule.

Mesonotum, scutellum, and part of pleuron (pro-, meso-, and sternopleuron) polished; notal hairs sparse, as in *polita*, but not as long and conspicuous as in that species; two pairs of dorsocentral bristles, the posterior pair long and well developed, the presutural pair only about half as long, but clearly standing out

from the mesonotal hairs, especially as seen in profile; pteropleuron without bristles.

Abdomen shining, the dorsum finely shagreened, terga with minute hairs, appearing bare except under high magnification; terminalia (Fig. 1) with both forceps and lamella well developed, the latter with numerous long bristles.

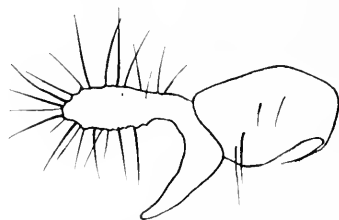

FIG. 1. Male terminalia of *Meconcrea californica*.

Legs short, the basitarsi moderately short; fore femur with a strong preapical posteroventral bristle on distal fourth, followed by short hairs.

Venation as usual for the genus; costa beyond first vein with the usual short, regular setae; costa, third, and fifth veins strong, second vein slender but distinct, the fourth pale and weak; second vein bisinuate, shorter than in *polita*, the second costal sector (between apices of veins 1 and 2) 3.7 times the length of third sector, the third subequal to or barely longer than (1.05) the fourth sector; fourth vein weakly sinuate.

Female.—As described for male, except for terminalia.

Length of body, 1.5 mm; of wing, 1.25 mm.

*Holotype* male, *allotype*, and one male, five female paratypes, Borrego Valley, San Diego Co., CALIF., June 20, 1960, and one female paratype, Borrego Springs, Calif., January, 1961 (Bryan T. Whitworth), taken in Tinkham trap with rotten egg bait. Type No. 65670 in the U. S. National Museum, paratypes returned to the Bureau of Vector Control, California Department of Public Health. Also two female paratypes, Coachella Valley, Calif., Dec. 18, 1929 and Dec. 9, 1930 (R. W. Burgess), previously included as paratypes of *M. polita* Sabrosky [U. S. Nat. Mus.].



The genus *Meoneura* was revised by Sabrosky (1959, Ann. Ent. Soc. Amer. 52: 17-26), with a key to 12 species. The present new species closely resembles *M. polita* Sabrosky and will key to that species, but differs as shown in the following couplet:

- Frontal triangle distinct, smooth and polished,  $\frac{3}{4}$  or more the length of front; second costal sector 2.4-2.7 times the length of third sector, the latter longer than fourth (1.1-1.27 times); veins yellowish and wing membrane whitish; male terminalia simple, the lamella undeveloped (Sabrosky, 1959, Fig. 3) . . . . . *M. polita* Sabr.
- Frontal triangle poorly distinguished, subshining, minutely wrinkled, half as long as front; second costal sector distinctly longer than in *polita*, 3.7 times the length of third sector, the third and fourth subequal; veins brown and wing membrane brown tinted; male terminalia with lamella well developed (Fig. 1, herewith) . . . . . *M. californica*, n. sp.

#### **Pholeomyia vockerothi**, new species

Large species with four pairs of dorsocentral bristles, no outer verticals, a row of 3 mesopleural bristles, and silvery dorsum of abdomen.

Male.—Black to black-brown, dull, brownish-gray pollinose except for the brilliant silvery dorsum of abdominal segments 2 through 5; wing hyaline, veins pale brown and membrane light brown tinted; calypteres brown with brown fringe.

Front slightly wider than that of *indecora* (Loew), at the vertex subequal to eye width and 0.38 times the width of head, sides slightly converging anteriorly, at the lunule the front 0.26 times the head width; postvertical bristles almost parallel, weakly divergent; outer vertical bristles absent; lunular bristles weak; face weakly concave, gray pollinose but subshining; parafacial linear; cheek very narrow, sublinear directly below eye, slightly widening anteriorly to vibrissa; proboscis short.

Mesonotum with four pairs of dorsocentral bristles, the anterior bristle in each row, close to the mesonotal suture, only half the length of the following bristle; two pairs of well-developed postsutural acrosticals, on posterior slope of mesonotum, the

presuturals especially well developed; mesopleuron with three strong bristles in a single row. Abdomen broad and flat, twice the width of thorax, abdominal terga 2 through 4 each with one row of short, fine, black hairs near posterior margin; abdominal sterna narrow, the fourth and fifth sparsely beset with hairs; sternum 4 narrow as in *expansa* Aldrich; sternum 5 subtriangular, broadened distally.

Wing venation approximately as in *indecora*; costal excision only moderately deep, intermediate between *indecora* and *expansa*, 1.7 times the length of small crossvein.

Length of body, 5 mm; of wing, 4 mm.

*Holotype* male, Highlands, N. C., 3,800 ft, June 24, 1957 (J. R. Vockeroth), "at light during heavy rain." Type in the Canadian National Collection, Ottawa.

*Pholeomyia vockerothi* is characterized by an interesting combination of characters. As may be seen in my recent revision of the genus (Sabrosky, 1959, Ann. Ent. Soc. Amer. 52: 316-331), the new species belongs with the few species (*longiseta* Becker, *latifrons* Sabrosky, *indecora* (Loew), and *expansa* Aldrich) in which there are three to four pairs of dorsocentral bristles and parallel or subparallel postverticals. Three of the four species have the thorax and abdomen concolorous in both sexes, gray to brown-gray pollinose. The striking silvery abdomen of *vockerothi* obviously resembles that of the fourth species, *P. expansa*, known only from California. However, several characters of the new species correspond to those of the common and widespread *P. indecora*, notably the presence of only three mesopleural bristles, absence of outer verticals, and brown wing. In the depth of the costal excision, *vockerothi* is intermediate between *indecora* and *expansa*, and in width of cheek it is narrower than either.

The range of *vockerothi* may be extremely limited. It was collected in the area in western North Carolina that has a localized fauna with striking relationships to the distant fauna of the far western states (e.g., the acrocerid genus *Eulonchus*), and its apparent relationship to the Californian species *expansa* suggests that it may be one of these localized species.

The new species will pass to couplet 4 in the key by Sabrosky (1959), which can be modified as follows, using first those characters that are known to apply to both sexes in this genus, although females of both *expansa* and *vockerothi* are still unknown:

4. Mesopleuron with three bristles in a single row along posterior margin; wing brown tinted; male lacking outer verticals.....4a.  
 — Mesopleuron more heavily bristled, typically with seven bristles in two rows; wing whitish; male with long, strong outer verticals (Calif.).....*P. expansa* Ald.  
 4a. Cheek narrow, sublinear below eye; dorsum of male abdomen silvery except for narrow first tergum (N.C.)....  
 .....*P. vockerothi*, n. sp.  
 — Cheek broad for the genus, slightly less than breadth of third antennal segment; thorax and abdomen concolorous in both sexes, gray to brown-gray pollinose (widespread, U. S. and Canada).....*P. indecora* (Loew).

#### TRIXOSCELIDAE

##### *Spilochroa geminata*, new species

Wing with numerous hyaline spots, and abdomen polished black.

Male, female.—Color, pollinosity, and habitus as in the common *ornata* (Johnson). Dull, gray to grayish brown; front yellow, especially anteriorly, the parafrontal, face, and cheek whitish and frontal triangle gray-brown; antenna yellow above, third segment black to brown below, especially on outer surface. Thorax gray with some inconspicuous brown markings; small brown spots about the bases of bristles and hairs. Abdomen polished black except for dull, brownish basal segment, and, in the male, the large, dull, finely brown pollinose terminalia. Legs yellow, fore femur slightly infuscated on outer side. Wing, except at base, brown with numerous hyaline spots; subcostal cell hyaline with central brown spot. Hairs and bristles black.

Anatomy and chaetotaxy as in *S. ornata*, the type-species. Wing venation as figured for *ornata* (Williston, 1908, Manual N. Amer. Diptera, ed. 3, p. 297); wing with pattern of hyaline

spots similar to *ornata*, but marginal cell with three large, evenly distributed, subquadrate spots, the median larger than either of others; submarginal and first posterior cells each with two spots close together, directly behind the large median spot in marginal cell, and discal cell with two large spots beyond level of small crossvein; spotting in other areas much like that of *ornata*.

Length of body and of wing, 2.5–3 mm.

*Holotype* male, and *allotype*, Buckeye, Maricopa Co., ARIZ., Jan. 18, 1961 (A. N. Villa). Type No. 65671 in the U. S. National Museum. Paratypes: 2 males, 6 females, same data as holotype; 2 females, same locality, Dec. 9, 1960 and Jan. 11, 1961; male, 3 miles s. of Cave Creek Postoffice, Maricopa Co., Ariz., June 1952, at light (H. K. Gloyd); male, 2 females, Avondale, Ariz., Dec. 6, 1960; 2 males, Tucson, Ariz., June 17, 1917 (J. M. Aldrich); male, Imuris, Sonora, Mexico, Apr. 16, 1952 (R. E. Ryckman). The 1960–61 specimens were collected in Steiner fruit fly traps.

A key to the four Nearctic species of *Spilochroa* was published by Wheeler (1955, *Wasmann Jour. Biol.* 13: 111–112). The new species will key to *S. polita* Malloch, both having a subcostal cell with dark spot centrally, and abdomen polished black. The new species has a more thickly spotted wing, with pairs of subquadrate spots as noted, in the submarginal, first posterior, and discal cells, whereas in *polita* there is only a single, small, rounded hyaline spot at each of the points mentioned and the wing thus appears predominantly brown. No males of *polita* are available for comparisons of the male terminalia.

A geographical separation from *polita* is possible, but present material is too limited to be sure. All known specimens of *polita* were collected in New Mexico and Texas, and those of the new species in Arizona and Sonora.

## New Exotic Crane-Flies (Tipulidae: Diptera). Part IV

CHARLES P. ALEXANDER, Amherst, Massachusetts<sup>1</sup>

The preceding part under this general title was published in ENTOMOLOGICAL NEWS, 72: 113-121; 1961. At this time I am considering species of the genus *Hexatoma*, chiefly from various parts of India where they were taken by Dr. Fernand Schmid, and including two from the Philippines, where they were taken by Mr. Charles F. Clagg and Dr. Edward S. Ross. Except where indicated to the contrary, the types of the novelties are preserved in my personal collection of these flies.

### *Hexatoma (Eriocera) prolixa* new species

Belongs to the *longicornis* group; size medium (wing under 10 mm); antennae of male elongate, approximately twice the length of the wing; general coloration gray, praescutum with three darker stripes; wings with  $R_{1+2}$  slightly longer than either  $R_2$  or  $R_{2+3}$ .

♂. Length about 6-6.5 mm; wing 7.5-8 mm; antenna about 12-16 mm.

♀. Length about 7-8 mm; wing 7.5-9 mm; antenna about 1.3-1.5 mm.

Rostrum short, light brown, sparsely pruinose; palpi with proximal segments brown, terminal segment black. Antennae of male 6-segmented, elongate, approximately twice the length of the wing, dark brown; flagellar segments greatly lengthened, especially the terminal one; segments with a dense erect white pubescence, with very sparse larger emergence bristles that are very small on the basal segment, becoming longer and more delicate on the terminal one; antennae of female short, apparently 9-segmented, the segments gradually decreasing in length outwardly. Head gray, clearer laterally behind; vertical tubercle

<sup>1</sup> Contribution from the Entomological Laboratory, University of Massachusetts.

of male large, rounded, with an impressed line on either side; tubercle in female very reduced.

Pronotum dark brown. Mesonotum gray, praescutum with three brown stripes, the median one narrowed behind, in front vaguely divided by a darker capillary vitta; vestiture sparse, pale. Halteres with stem brownish yellow, knob dark brown. Legs with coxae dark brown; trochanters more yellowed, especially beneath; remainder of legs brownish black, femoral bases obscure yellow, more extensively so on the posterior legs. Wings weakly darkened; stigma oval, very slightly indicated; veins brown, the outer medial branches paler. Veins chiefly glabrous, beyond cord with abundant trichia on  $R$ ,  $R_1$ ,  $R_3$ ,  $R_4$  and a complete series on distal section of  $R_5$ ; a few trichia on distal section of  $M_{1+2}$  in some cases; basal veins glabrous, including  $Sc$ . Venation:  $Sc$  long,  $Sc_1$  ending opposite fork of  $R_s$  to shortly before level of  $r-m$ ;  $R_2$  subequal to  $R_{2+3}$ , both shorter than  $R_{1+2}$ ;  $m-cu$  shortly beyond fork of  $M$ .

Abdomen chiefly blackened, sparsely pruinose to appear plumbeous. Ovipositor with fleshy valves, as in the group.

*Habitat.* INDIA (Kumaon). *Holotype*: ♂, Koti, Pauri Garhwal, 4,200 feet, August 30, 1958 (Fernand Schmid). *Allotopotype*: ♀, pinned with type. *Paratypes*: 1 ♂, Lingari, Pauri Garhwal, 4,400 feet, September 1, 1958; 1 ♀, Lohajang, Pauri Garhwal, 6,070 feet, August 21, 1958; 3 ♂♀, Maupata, Pauri Garhwal, 4,500 feet, September 2, 1958; 1 ♂, Wan, Pauri Garhwal, 7,880 feet, August 20, 1958; 1 ♂, Bilap, Almora, 5,500 feet, September 6, 1958 (Fernand Schmid).

*Hexatoma (Eriocera) prolixa* is distinguished from other regional members of the *longicornis* group by its small size and comparative shortness of the male antennae, which are only about twice the wing length.

### *Hexatoma (Eriocera) serena* new species

Size medium (wing of female 10 mm); general coloration black, surface subnitidous; legs black, femoral bases broadly yellow; wings strongly darkened, base conspicuously light yel-

low; veins with abundant macrotrichia;  $R_{2+3+4}$  and  $R_{1+2}$  subequal,  $R_2$  and  $R_{2+3}$  short, nearly equal,  $m-cu$  at or beyond midlength of  $M_{3+4}$ ; abdomen black, genital segment orange, ovipositor with cerci very long and slender.

♀. Length about 12 mm; wing 10 mm; antenna about 1.2 mm.

Rostrum and palpi black. Antennae of female short, 7-segmented; first segment of flagellum enlarged at base, narrowed outwardly, with a few long setae, the longest exceeding one-half the length of segment; succeeding three segments progressively shorter, terminal segment long, more than twice the length of the penultimate. Head black.

Thorax uniformly black, surface subnitidous; praescutal and scutal setae long, black. Halteres blackish, base of stem orange. Legs with coxae black, trochanters brown, remainder of legs black, the femoral bases broadly yellow, slightly more extensively so on posterior legs where nearly the proximal half is included. Wings strongly darkened, especially along the veins, centers of the cells slightly paler; prearcular field conspicuously light yellow, proximal ends of cells  $C$  and  $Sc$  less evidently brightened; veins brown, paler in the yellow areas. Veins of outer two-thirds of wing with abundant macrotrichia, including also all of veins  $Sc$ ,  $R$  and  $M$  and outer half of  $Cu_1$  and  $1st A$ ; a few trichia at extreme outer end of vein  $2nd A$ . Venation:  $Sc_1$  nearly opposite fork of the long  $Rs$ ;  $R_{2+3+4}$  and  $R_{1+2}$  subequal or the former a trifle longer;  $R_2$  and  $R_{2+3}$  short, nearly equal; basal section of  $R_5$  about one-half  $R_{2+3+4}$ ; cell  $1st M_2$  a little shorter than  $M_4$ ;  $m-cu$  at or just beyond midlength of  $M_{3+4}$ ; distal section of  $Cu_1$  in longitudinal alignment with the basal section. Surface of wing of type showing loose hairs lying on but detached from the membrane.

Abdomen brownish black, without differentiated basal rings; genital shield orange. Ovipositor with long, very slender cerci.

*Habitat.* INDIA (Kerala). *Holotype:* ♀, Periyakanal, 5,000–5,500 feet, December 17, 1958 (Fernand Schmid).

From other generally similar medium-sized regional species of the subgenus the present fly is readily told by the body coloration, and by the pattern, venation and trichiation of the wings. Such species include *Hexatoma (Eriocera) anamalaiana* Alexander, *H. (E.) tacita* Alexander, and *H. (E.) politovertex* Alexander.

### **Hexatoma (Eriocera) phaeton** new species

Size medium (wing of male 9.5 mm); general coloration of thorax polished black; legs black, femoral bases narrowly yellowed; wings strongly darkened, unpatterned;  $Sc_1$  ending opposite fork of  $Rs$ ,  $R_{2+3}$  about twice  $R_2$ , cell  $1st M_2$  long-rectangular, cell  $2nd A$  narrow; abdomen black, the basal segments obscure yellow.

♂. Length about 9 mm; wing 9.5 mm; antenna about 1.7 mm.

Rostrum very short, brownish black; palpi black. Antennae of male 7-segmented, black throughout; first flagellar segment nearly as long as the succeeding two combined, stouter, with relatively sparse coarse setae; antepenultimate segment subequal to the terminal one, both shorter than the penultimate. Head black, more or less pruinose above.

Pronotum brownish black. Mesonotum shiny black; praescutal setae small and very sparse. Pleura black, posterior sclerites and pleurotergite a trifle paler. Halteres light brown, apex of knob darker brown. Legs with coxae black; trochanters brownish yellow beneath, darker above; remainder of legs black, femoral bases narrowly yellowed. Wings strongly darkened, unpatterned, with no trace of stigmal darkening; a whitish streak in basal half of cell  $1st A$  adjoining the vein; veins brown,  $Sc$  and  $R$  more yellowed. Strong macrotrichia on most veins beyond cord, sparse on  $M_3$ , lacking on  $M_1$ ,  $Cu_1$  and both Anals; on  $Sc$  well distributed over the entire length;  $R$  with numerous microscopic setigerous punctures before the arculus, very small but more abundant near extreme base.



Venation:  $Sc$  moderately long,  $Sc_1$  ending opposite fork of  $Rs$ ;  $R_{2+3+4}$  and  $R_{1+2}$  subequal or the latter slightly longer, shorter than  $R_{2+3}$ , the latter about twice  $R_2$ ; cell *1st*  $M_2$  long-rectangular, slightly shorter than the distal section of  $M_{1+2}$ ;  $m-cu$  about one-third its length beyond the fork of  $M$ , longer than the distal section of  $Cu_1$ , which is not bent markedly basad; cell *2nd*  $A$  narrow.

Abdomen black, sides of basal tergite and proximal third of the second obscure yellow, posterior borders of segments very narrowly pale; no differentiated basal rings; outer segments with conspicuous setae, long and yellow on the sternites, black and much shorter on the tergites.

*Habitat.* INDIA (Madras). *Holotype:* ♂, Kumili, 2,000–2,500 feet, November 28, 1958 (Fernand Schmid).

The most similar regional members of the subgenus include *Hexatoma (Eriocera) serena* new species and *H. (E.) rama* Alexander, all readily told among themselves by the body and wing coloration and by the venation and trichiation of the wings.

#### **Hexatoma (Eriocera) furtiva** new species

Size medium (wing of male about 12 mm); head and thorax black, pruinose; praescutum dark gray with four opaque black stripes that are narrowly bordered by more intense black; legs black; wings strongly tinged with brown, the prearcular and costal fields strongly so; outer radial veins with abundant macrotrichia;  $R_{1+2}$  long, cell  $M_1$  present; abdomen black, segments two to four orange yellow.

♂. Length about 15 mm; wing 12.3 mm; antenna about 3 mm.

Rostrum and palpi black. Antennae of male 8-segmented, black; first flagellar segment shorter than the succeeding two combined; all flagellar segments with long setae, stouter on the more proximal segments. Head black, gray pruinose, with long coarse proclinate bristles; vertical tubercle porrect.

Pronotum black, sparsely pruinose. Mesonotal praescutum dark gray, with four opaque black stripes that are narrowly bordered by more intense black, including a central vitta; posterior sclerites black, subopaque; praescutum with abundant short black setae. Pleura dull black, pruinose. Halteres short, black. Legs with coxae and trochanters black, the former opaque, fore pair with abundant long setae; remainder of legs black; segments without scales. Wings strongly tinged with brown, the prearcular and costal fields strongly so, stigma not further differentiated; veins brown, outer veins behind the radial field paler and more delicate. Outer radial veins with abundant trichia, sparse or lacking on  $R_{2+3+4}$  and  $R_{2+3}$  present on both sections of  $R_5$ ; scattered trichia on  $M_1$ , very sparse on  $M_2$  and  $M_3$ . Venation:  $Sc$  long,  $Sc_1$  ending opposite  $R_2$ ,  $Sc_1$  long, exceeding  $R_{2+3}$ ;  $R_{1+2}$  very long, about four times  $R_2$ ; cell  $M_1$  present, subequal in length to its petiole;  $m-cu$  at near midlength of  $M_{3+4}$ ; vein  $2nd A$  long and sinuous.

First abdominal segment dull black, segments two to four, inclusive, orange yellow, unpatterned except for vague lateral darkenings on segments three and four; basal rings not differentiated; segments five to nine, including hypopygium, intensely black, subnitidous.

*Habitat.* INDIA (Kumaon). *Holotype:* ♂, Rishikesh, Dehra Dun, 1,200 feet, March 25, 1958 (Fernand Schmid).

The most similar regional species is *Hexatoma (Eriocera) semilimpida* (Brunetti) which differs conspicuously in the pattern of the body and wings.

### **Hexatoma (Eriocera) apoensis** new species

Belongs to the *rubrescens* group; mesonotum obscure orange, with two small brown lateral spots, pleura more yellowed with two further darkened areas; legs obscure yellow; wings brownish yellow, unpatterned except for the very small brown stigma; basal section of  $R_5$  very reduced, cell  $M_1$  present, subequal in length to its petiole, cell  $1st M_2$  rectangular, with  $m-cu$  at near midlength; basal abdominal segments orange, the outer ones orange, hypopygium brownish yellow.

♂. Length about 8 mm; wing 11 mm; antenna about 1.8 mm.

Rostrum and palpi black. Antennae of male 8-segmented; scape and pedicel brownish yellow, flagellum light brown; first flagellar segment stout basally, narrowed on outer half, a little shorter than the succeeding two combined; segments two and three subequal, the former with very long verticils, the longest only a little shorter than the segments; outer three segments gradually decreasing in length. Head light gray, center of disk extensively infuscated; vertical tubercle low.

Pronotum orange, pretergites yellow. Mesonotal praescutum chiefly obscure orange, produced by four confluent stripes, humeral and lateral regions paler; a distinct brown spot on side of praescutum behind the pseudosutural foveae; posterior interspaces vaguely darkened; scutum obscure orange, with a darkened median area just behind the suture and a pair at ends of the latter; scutellum and postnotum paler brownish yellow; vestiture of notum exceedingly reduced. Pleura obscure yellow, with small darkened areas on anepisternum and before the wing root. Halteres infuscated. Legs with coxae and trochanters testaceous yellow; remainder of legs obscure yellow, outer tarsal segments weakly more darkened; legs with abundant linear scales, paler in color than the larger setae. Wings brownish yellow, unpatterned except for the very small darker brown stigma; veins brown. Veins delicate, with macrotrichia beyond cord and on outer two-thirds of  $R_s$ . Venation:  $R_s$  long, in longitudinal alignment with  $R_5$ , basal section of the latter very reduced;  $R_{2+3+4}$  a trifle longer than  $R_{1+2}$  or  $R_2$ ; cell  $M_1$  present, subequal in length to its petiole; cell 1st  $M_2$  rectangular, with  $m-cu$  at near midlength; cell 2nd  $A$  relatively narrow.

Abdomen with basal three or four segments orange, outer segments brown, darker before the brownish hypopygium.

*Habitat.* PHILIPPINES (Mindanao). *Holotype:* ♂, Mount Apo, 6,000 feet, September 10, 1930 (C. F. Clagg).

*Hexatoma (Eriocera) apoensis* is most nearly related to *H. (E.) angustipennis* (Enderlein), of Sumatra, and *H. (E.) rubrescens* (Walker), of Borneo, differing in the coloration,

especially of the thorax. The elongate scales on the legs are found in all members of the *rubrescens* group that are known to me.

### **Hexatoma (Eriocera) rossiana** new species

Size small (length, wing and antennae all about 8 mm); general coloration black, outer two abdominal segments orange; antennae of male 5-segmented, flagellar segments progressively shorter outwardly, provided with an abundant pale pubescence but without bristles; knobs of halteres whitened; wings strongly infuscated, veins beyond cord with abundant trichia; cell  $M_1$  present, very deep; *m-cu* at near four-fifths the length of cell 1st  $M_2$ .

♂. Length about 8 mm; wing 8 mm; antennae about 8.2 mm.

Rostrum relatively small, light brown; palpi brownish black. Antennae of male elongate, subequal to body or wing; scape ferruginous, remainder dark brown to brownish black; 5-segmented, there being only three very long flagellar segments that decrease gradually in length and diameter from the basal one outwardly; segments with a very abundant erect pale pubescence but without emergence bristles, as are common in most species of the genus having elongate antennae in the male sex. Head dull black, slightly patterned with paler on the inconspicuous slightly bifid vertical tubercle; sides of vertex and genae adjoining the eyes slightly pruinose.

Pronotal scutum dark brown, obscure yellow medially, scutellum similarly brightened. Mesonotal praescutum with the ground dull black, with four poorly indicated plumbeous stripes, the intermediate pair narrowly separated by a distance nearly equal to their own width; remainder of notum dull black, posterior border of mediotergite more pruinose; mesonotum unusually glabrous, the vestiture reduced to sparse erect scattered setae on the scutellum and praescutal interspaces. Pleura dull plumbeous black; membrane darkened. Halteres with stem dusky, base restrictedly obscure yellow, knob whitened. Legs black throughout, vestiture short and appressed. Wings very

strongly infuscated, somewhat more so on anterior half, stigma not differentiated; a whitened streak behind basal third of vein *1st A*; veins brown. Veins beyond cord with numerous macrotrichia, on *M* continued basad to about opposite origin of *Rs*. Venation: *Sc* long, *Sc*<sub>1</sub> ending beyond fork of *R*<sub>2+3+4</sub>, *Sc*<sub>2</sub> far retracted; *Rs* long, slightly exceeding *R*<sub>4</sub>; *R*<sub>2+3</sub> a little shorter than *R*<sub>1+2</sub>; cell *M*<sub>1</sub> present, about three times its petiole; cell *1st M*<sub>2</sub> elongate, with *m-cu* at near four-fifths its length.

Abdomen black, eighth and ninth segments orange; hypopygium very small and inconspicuous, provided with long pale setae.

*Habitat.* PHILIPPINES (Mindoro). *Holotype:* San Jose, April 5, 1945 (E. S. Ross); California Academy of Sciences.

This very distinct fly is named for its collector, Dr. Edward S. Ross, authority on the Embioptera and other groups of insects. In the very long *Rs*, which is about twice as long as *R*, the fly differs from all other described regional species. The reduction in number of antennal segments to five likewise is noteworthy. By Edwards's key to the Old World species of *Eriocera* (1921) the fly runs to couplet 35, disagreeing with all species beyond this point.

---

## Mosquitoes: Key to United States Genera Based on Male Genitalia (Diptera, Culicidae)

HAROLD GEORGE SCOTT<sup>1</sup>

With the sustained interest in identification of Diptera via characteristics of the male genitalia (Fig. 1), simple keys to the various groups have become essential to efficient entomological instruction. The following key, devised for CDC training courses, has proven valuable in introducing this taxonomic method.

<sup>1</sup> Training Branch, Communicable Disease Center, Public Health Service, U. S. Department of Health, Education, and Welfare, Atlanta, Georgia.

The failure of *Aedes aegypti* to key out with other members of the genus (steps 2 and 12 of key), lends credence to the concept that this is an African species, only distantly related to Nearctic aedines.

1. Basistyle with 1-2 stout spines near base; phallosome 4 or more times as long as wide, often with leaflets at tip. . . . .  
     . . . . . **Anopheles**  
     Basistyle without basal spines; phallosome less than 4 times as long as wide, without leaflets at tip. . . . . 2
2. Claspettes present (absent in *Aedes aegypti*). . . . . 3  
     Claspettes absent. . . . . 5
3. Dististyle strongly swollen (rarely lobate); *or* dististyle bowed inward; *or* both. . . . . **Psorophora**  
     Dististyle not strongly swollen; straight, or bowed outward. . . . . 4
4. Large leaf-like scales on distal lobe of basistyle. . . . .  
     . . . . . **Haemogogus**  
     Without large leaf-like scales on distal lobe of basistyle. . . . .  
     . . . . . **Aedes**
5. Tenth sternite with comb of teeth or crowned with tuft of spines. . . . . 6  
     Tenth sternite simple or with a few apical teeth. . . . . 7
6. Lobe of ninth tergite less than one-half as long as basistyle. . . . . **Culex**  
     Lobe of ninth tergite at least one-half as long as basistyle. . . . . **Deinocerites**
7. Dististyle with 3 or more branches. . . . . **Wyeomyia**  
     Dististyle simple or with a single lobe near base. . . . . 8
8. Phallosome plate-like, with 1 or more large teeth on each side. . . . . **Uranotaenia**  
     Phallosome sub-conical, often with small teeth near tip. . . . 9
9. Basal lobe of basistyle with 1-2 rods at apex, few or no setae. . . . . **Mansonia**  
     Basal lobe of basistyle with spines, numerous small setae. . 10
10. Claw of dististyle comb-like. . . . . **Orthopodomyia**  
     Claw of dististyle spine-like. . . . . 11
11. Outer edge of basistyle with large scales. . . . . 12  
     Outer edge of basistyle without large scales. . . . . **Culiseta**
12. Dististyle cylindrical, with subapical spine. . **Toxorhynchites**  
     Dististyle tapering, with apical spine. . . . . **Aedes aegypti**

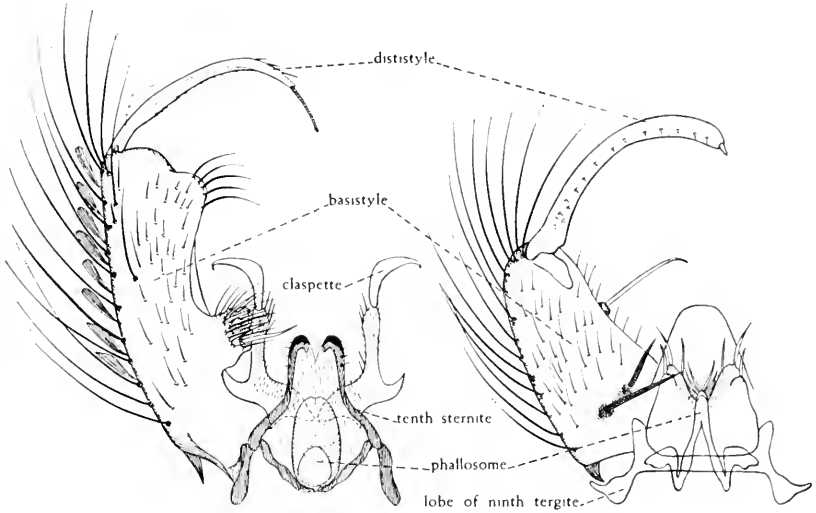

*Aedes dorsalis*

*Anopheles punctipennis*

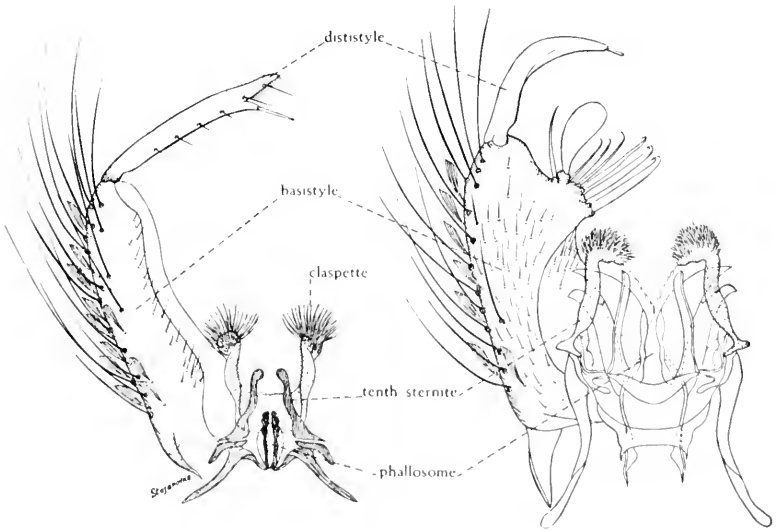

*Aedes vexans*

*Culex quinquefasciatus*

Fig. 1. MALE GENITALIA OF MOSQUITOES

## An Unusual Habitat Niche for *Ancistrocerus tigris tigris* (Saussure) (Hymenoptera: Vespidae)<sup>1</sup>

HARRY C. COPPEL<sup>2</sup>

Field investigations on the introduced pine sawfly, *Diprion similis* (Htg.), in 1959 showed that approximately 10% of the cocoons from which adult sawflies had emerged were inhabited by various arthropods (Coppel, 1960). First generation cocoons are usually spun on the needles and branches of white pine trees. Though most of the inhabited cocoons were used by spiders, approximately 8% were observed with mud plugs covering the sawfly emergence holes (Fig. 1). These were placed singly in vials and incubated until emergence was complete. The adult wasps, all males, were determined as *Ancistrocerus tigris tigris* (Saussure) by K. V. Krombein of the U. S. National Museum, Washington, D. C. This species is indigenous to North America and is widespread in the United States and Southern Canada where it has been bred from twigs, oak galls, goldenrod galls, old wasp nests etc. Apparently, empty sawfly cocoons have not been observed as habitat niches previously, and females of the genus *Ancistrocerus*, in general, construct and provision a linear series of cells.

In 1960, a simple sandwich-type artificial nest was constructed (Fig. 2) to see whether females of *A. t. tigris* could be attracted to single cocoons in parallel. It consisted of two rows of cocoons, the upper one containing empty cocoons from which female sawflies had emerged and the lower one empty cocoons from which males had emerged. These were backed with cocoons in similar rows but in reverse placement (male cocoons above female cocoons), and were suspended approximately 6 feet above the ground, from branches of white pine trees. Though most of the nests were destroyed by vandals one remained which had been utilized by the wasp. Of its eleven

<sup>1</sup> Approved for publication by the Director of the Wisconsin Agricultural Experiment Station. This work was supported in part by the Wisconsin Conservation Department.

<sup>2</sup> Associate Professor, Department of Entomology, University of Wisconsin, Madison 6, Wisconsin.



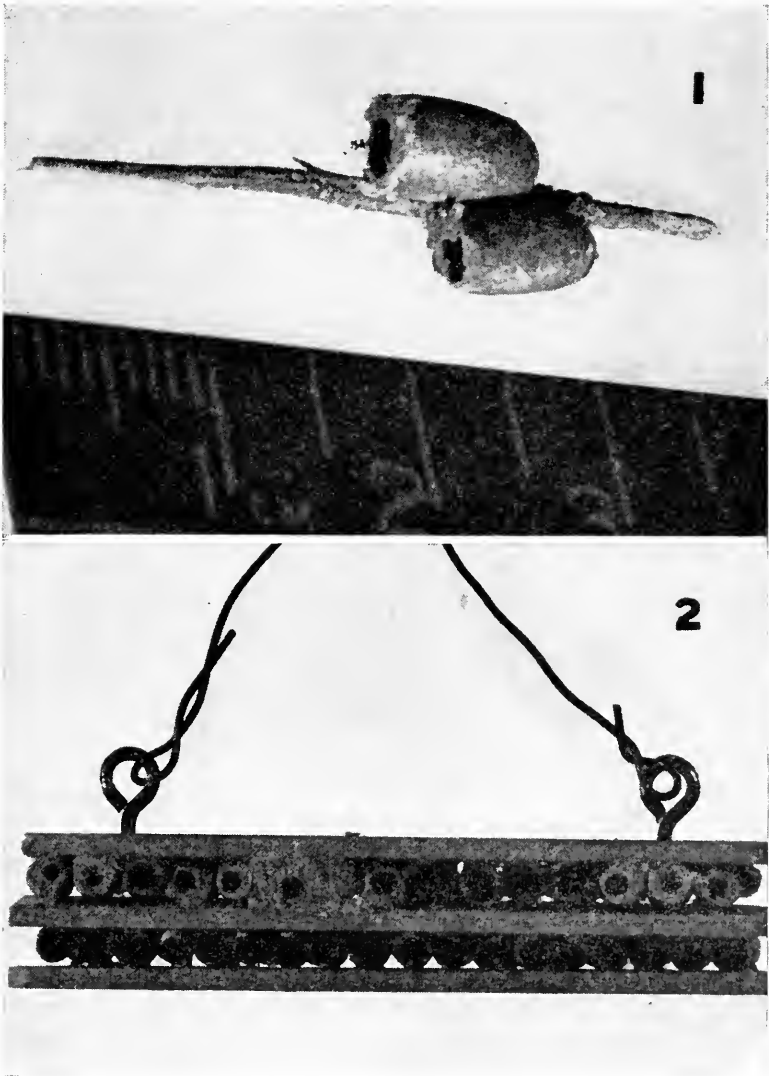

FIG. 1. Cocoons of *Diprion similis* (Htg.) on white pine twig, showing emergence holes of *Ancistrocerus tigris tigris* (Saussure) through mud plugs.

FIG. 2. Artificial nest used to attract *Ancistrocerus tigris tigris* (Saussure), showing preference for upper row of larger female sawfly cocoons.

mud-plugged cocoons ten produced adult wasps, of which four were males, four females, and two escaped. The only cocoons utilized were those from which female sawflies had emerged and whose emergence holes ranged from 3.2 to 3.6 mm in diameter.

Some wasp larvae in the cocoons were parasitized by insects in 1959. *Monodontomerus dentipes* (Dalm.) (Hymenoptera: Torymidae), an European parasite of *D. similis* larvae in cocoons was obtained as were two native ichneumonid parasites determined by Miss L. Walkley, U. S. National Museum, Washington, D. C., as *Agrothereutes lophyri* subsp. n., and *Ephialtes* sp. Apparently, the sawfly parasites *M. dentipes* and *A. lophyri*, which normally parasitize *D. similis* larvae in cocoons, also parasitize later occupants of the *Diprion* cocoons without discrimination.

#### REFERENCE

COPPEL, H. C. 1960. Ann. Ent. Soc. America 53: 847-849.

---

## Collembola from Rodent Nests

D. L. WRAY<sup>1</sup> and G. F. KNOWLTON<sup>2</sup>

Springtail insects or Collembola are found in a large number of diverse habitats and probably in more unique places than any other animal group. The objective of this paper is to report on those species found in the course of studying several kinds of rodent nests. Materials from these nests were collected and run through Berlese funnels by G. F. Knowlton and his associates. The determinations and systematic arrangement were made by D. L. Wray.

### 1. POCKET GOPHER NESTS (*Thomomys talpoides*).

These were collected at Monte Cristo, Utah on July 18, 1951 by G. F. Knowlton and T. T. Tibbetts. The following five species were found in the nests:

<sup>1</sup> Entomologist, Div. of Entomology, Dept. of Agriculture, Raleigh, N. C.

<sup>2</sup> Utah State University, Logan, Utah.

*Hypogastrura nivicola* Fitch, 1 specimen; *Isotoma olivacea* Tullberg, numbering in the thousands; *Isotoma brucealla* Wray, 24; *Isotoma nigrifrons* Folsom, 20; and *Entomobrya purpurascens* Packard, 1.

## 2. ABANDONED MOUSE NEST.

Materials from this nest were collected at American Falls, Idaho, April 9, 1952 by G. F. Knowlton and J. V. Bruce.

The following seven species were found:

*Hypogastrura armata* Nicolet, in considerable numbers; *Hypogastrura promatro* Wray, few; *Folsomia guthriei* Linnaemi, few; *Isotoma eunotabilis* Folsom, few; *Entomobrya nivialis* Linnaeus, few; *Lepidocyrtus cyaneus* Tullberg, f.p., few; *Pseudosinella octopunctata* Boerner, few.

## 3. MOUSE NEST (*Microtus* sp.).

This nest was obtained at Hyde Park, Utah, June 29, 1950 by G. F. Knowlton and J. V. Bruce.

The following eight species were found, most in small numbers unless otherwise indicated:

*Hypogastrura matura* Folsom, considerable numbers; *Proisotoma aquae* Bacon, large numbers; *Isotoma minor* Schaeffer; *Isotoma eunotabilis* Folsom; *Lepidocyrtus cyaneus* Tullberg; *Pseudosinella sexoculata* Schött; *Pseudosinella alba* Packard; *Pseudosinella candida* Folsom.

## 4. PACK RAT NESTS (*Neotoma cinerea*).

(A). Nests collected at Logan Cave, Logan Canyon, Utah on October 19, 1951 by G. F. Knowlton and W. H. Wilde yielded the following two species:

*Agrenia bidenticulata* Tullberg, fifteen specimens; and *Entomobrya marginata* Tullberg, two specimens with blunt ending mucro. Also found were a few mites, small beetles, dipterous larvae, and a small adult diptera.

(B). Nests collected at Logan Cave, Logan Canyon, Utah on November 18, 1951 by G. F. Knowlton yielded the following three species:

*Folsomia fimetaria* Linn., few; *Entomobrya nivalis* Linn., small numbers; and *Lepidocyrtus pusillus* Linn., small number.

(C). Nests collected at Logan Cave, Logan Canyon, Utah on November 17, 1951 by G. F. Knowlton and B. K. Collmar produced the following six species:

*Tullbergia granulata* Mills, 1 specimen; *Folsomia fimetaria* Linn., few; *Isotoma eunotabilis* Folsom, few; *Entomobrya marginata* Tullberg, few; *Entomobrya nivalis* Linn., few; and *Lepidocyrtus pusillus* Linn., few.

#### SUMMARY

A summary of the number of species in each family that were found in rodent nests would be as follows:

#### Poduridae

*Hypogastrura armata* Nicolet, *H. nivicola* Fitch, *H. matura* Folsom, *H. promatro* Wray, *Tullbergia granulata* Mills.

#### Isotomidae

*Poisotoma aquae* Bacon, *Agrenia bidenticulata* Tullberg, *Folsomia guthriei* Linnaniemi, *F. fimetaria* Linnaeus, *Isotoma brucealla* Wray, *I. nigrifrons* Folsom, *I. eunotabilis* Folsom, *I. minor* Schaeffer, *I. olivacea* Tullberg.

#### Entomobryidae

*Entomobrya purpurascens* Packard, *E. nivalis* Linnaeus, *E. marginata* Tullberg, *Lepidocyrtus cyaneus* Tullberg, f.p., *L. pusillus* Linnaeus, *Pseudosinella sexoculata* Schött, *P. alba* Packard, *P. octopunctata* Boerner, *P. candida* Folsom.

Species belonging to the family Isotomidae were found more numerous than any in the other families. A total of 23 species belonging to 9 genera were found in the rodent nests examined.

Evidently the moisture condition was such as to be conducive for this wide range of species to live.

#### LITERATURE CITED

- WRAY, D. L. 1953. Bull. Brooklyn Ent. Soc. 48: 54-56.  
WRAY, D. L. and G. F. KNOWLTON. 1950. Bull. Brooklyn Ent. Soc. 45: 60-64.  
———. 1956. The Great Basin Naturalist 16: 1-6.
- 

### Obituary

It is with deep regret that we here record the death, on August 23rd, of Dr. **Philip P. Calvert**, Professor Emeritus of the University of Pennsylvania and Editor Emeritus of ENTOMOLOGICAL NEWS. At the time the NEWS was founded he was on its advisory committee, then became Associate Editor in 1893, and was Editor from 1911 until 1944. It is hardly conceivable that the NEWS could have survived the vicissitudes of its 72 years without the steadfast guidance and devoted service of Dr. Calvert. A biographical memorial will appear in a later issue of this publication.

# Entomologist's Market Place

## ADVERTISEMENTS AND EXCHANGES

Advertisements of goods or services for sale are accepted at \$1.00 per line, payable in advance to the editor.

Notices of wants and exchanges not exceeding three lines are free to subscribers.

All insertions are continued from month to month, the new ones are added at the end of the column, and, when necessary, the older ones at the top are discontinued.

---

**Butterflies.** Wish to exchange specimens for Japanese species. Please write to Ichiro Nakamura (Boy, age 16), 26 Aza-Nichiyama Obayashi Takarazuka-shi, Hyogo-Ken, Japan.

**Phasmidae** of nearctic area desired alive. Purchase or trade, drawing on large stock of major orders, worldwide. Domminck J. Pirone, Dept. Entomology, Cornell University, Ithaca, N. Y.

**Nitidulidae and Rhizophagidae** wanted in exchange for European beetles of all families. O. Marek, Zámberk 797, Czechoslovakia.

**Wanted and Needed.** We are compiling a history of entomology, and particularly, at present, of the amateur insect clubs that flourished 50 to 75 years ago. Will you who have knowledge of such early clubs or societies advise me, giving facts on the time of existence, members, etc., which you may have. J. J. Davis, Dept. of Entomology, Purdue University, Lafayette, Indiana.

**Cockroaches (Blattoidea)** of Japan, Okinawa, Formosa (Taiwan), and the Philippines are being studied in cooperation with Dr. K. Princis. Loans of specimens from that area are desired. A. B. Gurney, U. S. National Museum, Washington 25, D. C.

**Orthoptera. Gryllinae** (except domestic sp.) and **Pyrgomorphinae** of the world wanted in any quantity for work in morphology, taxonomy, cytology, and experimental biology; dry, or in fluid, or living. Write D. K. Kevan and R. S. Bigelow, Dept. of Entomology, McGill University, Macdonald College, Quebec, Canada.

**Beetles** of the world wanted, all species in exchange for American beetles, moths and butterflies. James K. Lawton (age 18), 7118 Grand Parkway, Wauwatosa 13, Wisconsin.

## Pacific Insects

A quarterly journal on the systematic entomology and zoogeography of the Pacific, East Asia, Australia and Antarctica.

Vols. 1-3 (over 500 pages per volume) each \$5.00  
Vol. 4 (1962) (over 700 pages) \$7.00

## Pacific Insects Monographs

Adjunct series appearing irregularly and not included in subscription. To be ordered separately or standing order placed.

- 1A. **The Chrysomelidae (Coleop.) of China and Korea.** Part I. By Gressitt and Kimoto. 299 pp., 75 figs. \$4.00
2. **Problems in the Zoogeography of Pacific and Antarctic Insects.** By Gressitt, with appendices by Maa, Mackerras, Nakata, and Quate. 128 pp., 40 figs. (incl. 2 color pls.). Bound, \$2.50. Paper, \$2.00

---

## Important Mosquito Works

**MOSQUITO ATLAS. Part I. The Nearctic Anopheles, important malarial vectors of the Americas, and Aedes aegypti and Culex quinquefasciata**

**MOSQUITO ATLAS. Part II. The more important malaria vectors of the Old World: Europe, Asia, Africa and South Pacific region**

By Edward S. Ross and H. Radclyffe Roberts

Price, 60 cents each (U. S. Currency) with order, postpaid within the United States; 65 cents, foreign.

---

### KEYS TO THE ANOPHELINE MOSQUITOES OF THE WORLD

With notes on their Identification, Distribution, Biology and Relation to Malaria. By Paul F. Russell, Lloyd E. Rozeboom and Alan Stone

Mailed on receipt of price, \$2.00 U. S. Currency. Foreign Delivery \$2.10.

---

For sale by the American Entomological Society, 1900 Race Street, Philadelphia 3, Pa., U. S. A.

Just Published

**MEMOIRS OF THE AMERICAN  
ENTOMOLOGICAL SOCIETY**

Number 17

**A TAXONOMIC STUDY OF THE  
MILLIPED FAMILY SPIROBOLIDAE  
(DIPLOPODA: SPIROBOLIDA)**

By William T. Keeton

147 pages of text, 37 tables, 2 maps, 18 plates,  
table of contents and index

Spirobolid millipeds are probably the most widely known Diplopoda in the United States, being used in many college courses; yet the family has been little studied. This monograph brings together existing knowledge of the group for the first time, and adds much new information gained from critical study of series. The taxonomic history of the family is outlined. External morphology is briefly treated, with emphasis on characters utilized in classification. A summary of current knowledge of life histories is included. The family is redefined, and each genus and species is treated in detail. Particular attention is given to variation and distribution, both of which become more meaningful biologically as a result of synonymizing many species names. Possible phylogenetic relationships of the genera are discussed, and keys to all taxa are provided, with most diagnostic characters illustrated in 18 plates or summarized in 37 tables.

Price \$5.50

---

**THE AMERICAN ENTOMOLOGICAL  
SOCIETY**

1900 Race Street, Philadelphia 3, Penna., U.S.A.



sects

Have you paid your subscription?

January and subsequent issues for 1962 positively  
not mailed unless subscription has been paid.

# ENTOMOLOGICAL NEWS

## DECEMBER 1961

Vol. LXXII

No. 10

---

### CONTENTS

Burks—The species of <i>Pseudometagea</i> Ashmead .....	253
Krombein— <i>Passaloecus turionum</i> in the U. S. ....	258
Balduf—A large population of <i>Polistes</i> .....	259
Scott—Collembola of New Mexico, V. ....	261
Porter— <i>Coccygomimus maurus</i> (Cresson) in N. J. ....	267
Notes and News in Entomology	
Revised International Code now ready .....	268
Nomenclature Notice .....	269

---

PUBLISHED MONTHLY, EXCEPT AUGUST AND SEPTEMBER, BY  
THE AMERICAN ENTOMOLOGICAL SOCIETY  
PRINCE AND LEMON STS., LANCASTER, PA.  
AND  
1900 RACE STREET, PHILADELPHIA 3, PA.

---

Subscription, per yearly volume of ten numbers: \$5.00 domestic; \$5.30 foreign; \$5.15 Canada.  
Second-class postage paid at Lancaster, Pa.



# ENTOMOLOGICAL NEWS

---

ENTOMOLOGICAL NEWS is published monthly, excepting August and September, by The American Entomological Society at Prince and Lemon Sts., Lancaster, Pa., and the Academy of Natural Sciences, 1900 Race Street, Philadelphia 3, Pa., U. S. A.

PHILIP P. CALVERT, Editor Emeritus. R. G. SCHMIEDER, Editor. Editorial Staff: H. J. GRANT, JR., E. J. F. MARX, M. E. PHILLIPS, and J. A. G. REHN.

**SUBSCRIPTIONS:** Communications and remittances to be addressed to Entomological News, 1900 Race Street, Philadelphia 3, Pa.

Prices per yearly volume of 10 numbers.

Private subscriptions, for personal use: in the United States, \$5.00; Canada, \$5.15; other countries, \$5.30.

Institutional subscriptions, for libraries, laboratories, etc.: in the United States, \$6.00; Canada, \$6.15; other countries, \$6.30.

**ADVERTISEMENTS:** Rate schedules available from the editor.

**MANUSCRIPTS** and all communications concerning same should be addressed to R. G. Schmieder, Zoological Laboratory, University of Pennsylvania, Philadelphia 4, Pa.

The receipt of all papers will be acknowledged and, if accepted, they will be published as soon as possible. Articles longer than eight printed pages may be published in two or more installments, unless the author is willing to pay the cost of a sufficient number of additional pages in any one issue to enable such an article to appear without division.

**ILLUSTRATIONS:** Authors will be charged as follows: For text-figures, the cost of engraving; for insert plates (on glossy stock), the cost of engraving plus printing. Size limit, when printed, 4×6 inches. All blocks will be sent to authors after printing.

**TABLES:** The cost of setting tables will be charged to authors.

**SEPARATA:** Members of the American Entomological Society may elect to receive, gratis, 25 offprints of their contributions. These will be "run-off-form," without removal of extraneous matter.

Those members desiring more than 25 separates, and all non-members, will receive no gratis copies. They must obtain all their separates (as reprints, with extraneous matter removed) from the printer at the prices quoted below. Authors must place their order for such separates with the editor at the time of submitting manuscripts, or when returning proof.

Copies	1-4 pp.	5-8 pp.	9-12 pp.	Covers
50	\$4.35	\$6.96	\$10.88	\$4.74
100	5.21	8.26	13.05	6.48
Add'l 100	1.74	2.60	4.33	3.48

Plates printed one side: First 50, \$3.47; Additional 100's, \$2.61.

Transportation charges will be extra.

# ENTOMOLOGICAL NEWS

VOL. LXXII

DECEMBER, 1961

No. 10

## The Species of *Pseudometagea* Ashmead (Hymenoptera, Eucharitidae)

B. D. BURKS, Entomology Research Division, United States Department of Agriculture

*Pseudometagea* Ashmead is a small genus of minute eucharitid chalcids occurring only in North America. Specimens of *Pseudometagea* look very much like ants, and they often are collected in sweeping vegetation. No specimens have yet been reared, but Ashmead once stated that his specimens of *P. schwarzii* (Ashmead) had come from ant nests.<sup>1</sup> It is likely that, in agreement with other members of the Eucharitidae for which the habits are known, the species of *Pseudometagea* parasitize ants, and their eggs are imbedded in the tissues of vegetation growing near the nests of their hosts. The planidiform larvae, when found, certainly will be extremely minute.

*P. schwarzii* has long been known from the eastern and mid-western states, but I recently received for identification a specimen of *Pseudometagea* from Wyoming that was clearly different from *schwarzii*. This prompted a search through the U. S. National Museum collection for other specimens of the western form. A long series of it that had been collected 66 years ago in Colorado was found. In this paper I describe the western species, redescribe *schwarzii*, and give one new synonym of *schwarzii*.

### Genus PSEUDOMETAGEA Ashmead

*Pseudometagea* Ashmead, 1897, Proc. Ent. Soc. Wash., 4: 239 [no species included]; Ashmead, 1904, Mem. Carnegie Mus.,

<sup>1</sup> Wheeler, 1907, *Bul. Amer. Mus. Nat. Hist.* v. 23, p. 17.

1: 267, 386 [*Metagea schwarzii* Ashmead designated type]; Peck in Muesebeck *et al.*, 1951, U. S. Dept. Agr. Monog. 2, p. 515; Burks in Krombein *et al.*, 1958, U. S. Dept. Agr. Monog. 2, Suppl., p. 72.

Generic diagnosis.—Mandibles sickle-shaped, left mandible with 2 teeth, right with 3. Antennae inserted at level of ventral margins of compound eyes; scape short, shorter than pedicel, much shorter than first funicle segment, the latter always the longest segment in antenna; no ring segments present; flagellum filiform in both sexes; funiculus with 6 or 7 segments in female, 7 segments in male; club unsegmented, not broader than funiculus,  $1\frac{1}{2}$  times as long in male as in female; apical 2 funicle segments and club in female may be partly fused, and the variation in number of funicle segments in the female may occur in the same individual. Vertex depressed between posterior ocelli.

Parapsidal furrows varying from complete and deep to almost or quite wanting. Fore wing with submarginal vein well developed, but marginal, stigmal, and postmarginal veins vague, hardly discernible. Mid and hind tibia each with one slender, apical spur; each basal tarsal segment twice as long as second segment.

Petiole enlarged and nodose in the middle, anterior two-thirds of petiole sculptured, posterior third smooth; gaster compressed, first gastral tergum occupying most or all of the dorsal extent of the gaster.

Ashmead originally described *schwarzii* in the Australian genus *Metagea* Kirby, but subsequently he decided that it was sufficiently distinct to require a different generic name. As a matter of fact, *Metagea* and *Pseudometagea* are not closely related. *Metagea* is a genus of moderate to large-sized species having the scape longer than the first funicle segment, the first tarsal segment as long as the following 4 segments combined, and the petiole not enlarged and nodose in the middle.

#### KEY TO SPECIES

- Scutellum with a longitudinal, median furrow . . . . .  
 . . . . . *schwarzii* (Ashmead)  
 Scutellum with several longitudinal carinae . . *bakeri*, new species

***Pseudometagea schwarzii* (Ashmead)**

*Metagea schwarzii* Ashmead, 1892, Proc. Ent. Soc. Wash. 2: 356.

*Pseudometagia schwarzi* (!) (Ashmead), Wheeler, 1907, Bul. Amer. Mus. Nat. Hist. 23: 17.

*Pseudometagea schwarzii* (Ashmead), Peck in Muesebeck *et al.*, 1951, U. S. Dept. Agr. Monog. 2, p. 515; Burks in Krombein *et al.*, 1958, U. S. Dept. Agr. Monog. 2, Suppl. p. 72.

*Pseudometagea hillmeadia* Girault, 1916, Bul. Brooklyn Ent. Soc. 11: 113; Peck in Muesebeck *et al.* 1951, U. S. Dept. Agr. Monog. 2, p. 515. New synonymy.

Female.—Length 1.8–2.2 mm. Dark chestnut-brown to black, with faint metallic blue or green sheen sometimes visible on head and thorax; antennae, apices of femora, tibiae, and tarsi tan to light-brown; fore wing with faint brown shading along paths of obsolete veins Cu and M, this shading also extending as a vague cloud across wing from stigmal vein.

Clypeus, para- and supra-clypeal areas, and space adjacent to anterior margin of compound eye smooth and shining; genae, parascrobal spaces, and vertex with irregular, rugose sculpture; length of malar space and height of compound eye equal; width of ocellular space twice as great as diameter of lateral ocellus. Antennal scape  $\frac{3}{4}$  as long as pedicel, first funicle segment  $1\frac{1}{2}$  times as long as pedicel.

Mesoscutum with alveolate sculpture anteriorly, smooth and shining posteriorly; parapsidal furrows usually complete, occasionally wanting; axillae smooth; scutellum smooth, with a median, longitudinal groove, this sometimes obscure near posterior margin; apex of scutellum produced as a minute, flat shelf; meso- and metapleura with closely set, parallel, longitudinal rugae; hind coxa shagreened, hind femur shining except at base, where it is shagreened. Hind wing with venation distinct, usually 4 hamuli present, sometimes with only 3.

Propodeum with large-alveolate sculpture; petiole slightly shorter than hind coxa, enlarged in middle to  $1\frac{1}{2}$  times width of hind coxa. Gaster smooth; first tergum usually occupying entire dorsal length of gaster, following terga vertical; each cercus bearing 5 bristles; apex of first gastral sternum a slightly

upturned point that bear 6-8 long bristles; apex of ovipositor normally not quite reaching apex of abdomen, but specimens collected apparently in the act of ovipositing have the ovipositor exerted a distance  $\frac{1}{3}$  the length of the gaster.

Male.—Length 1.8-2.0 mm. Height of compound eye  $\frac{9}{10}$  as great as length of malar space. Petiole twice as long as hind coxa, slender basal portion with a dorsal, longitudinal groove, enlarged portion twice as wide as hind coxa. First gastral tergum occupying entire dorsal extent of gaster, following terga normally telescoped beneath it, so that genitalia usually are extruded at about the middle of gaster; posterior margin of apical gastral sternum  $\cap$ -shaped, finely and minutely hirsute.

*Types*.—U. S. N. M. No. 2140. Described originally from 4 ♀, 2 ♂ cotypes from Washington, D. C., Oakland, Md., and Frederickstown, Md. Lectotype ♀, Washington, D. C., specimen labeled "♀ Type" by Ashmead.

*Distribution*.—Quebec, south to Maryland and District of Columbia, west to Wisconsin, Iowa, and Nebraska. Often collected in cultivated fields of forage crops.

### ***Pseudometagea bakeri*, new species**

Female.—Length 2.0-2.2 mm. Dark brown to black, head and thorax often with faint metallic blue or green sheen; antennae, apices of femora, tibiae, and tarsi tan to brown; fore wing usually with faint brown shading along paths of obsolete veins Cu and M, this shading also extending as a vague cloud across wing from stigmal vein, but occasional specimens with wings entirely hyaline.

Clypeus smooth, shining, para- and supraclypeal areas smooth; genae, postocular area, and vertex with irregular, alveolate sculpture; length of malar space  $1\frac{1}{3}$  times as great as height of compound eye; width of ocellocular space  $1\frac{1}{2}$  times as great as diameter of lateral ocellus. Antennal scape  $\frac{9}{10}$  as long as pedicel, first funicle segment  $1\frac{1}{3}$  times as long as scape.

Mesoscutum strongly sculptured anteriorly, weakly so posteriorly; parapsidal furrows usually vaguely impressed anteriorly and wanting posteriorly, sometimes complete; axillae faintly

sculptured, almost smooth; scutellum with strong, parallel, longitudinal ridges, apex of scutellum produced as a minute shelf with its posterior edge slightly upturned; meso- and metapleura with closely set, parallel, longitudinal rugae; hind coxa with minute, alveolate sculpture, all femora minutely shagreened and dull. Hind wing virtually without venation, but vestigial submarginal vein faintly visible; 3 hamuli present.

Propodeum with irregular, large-alveolate sculpture. Petiole as long as hind coxa, enlarged in middle to twice width of hind coxa. Gaster smooth, first tergum normally occupying  $\frac{1}{3}$  of dorsal length of gaster, terga 2-6 almost vertical, projecting slightly farther posteriorly than seventh tergum; each cercus bearing 5 bristles; apex of first gastral sternum produced on meson as a small, hirsute point; apex of ovipositor normally projecting slightly beyond level of sixth tergum.

Male.—Length 1.9-2.1 mm. Length of malar space and height of compound eye equal. Petiole twice as long as hind coxa. First gastral tergum occupying entire dorsal length of gaster, second and third terga normally hidden beneath first, terga 4-7 not projecting so far posteriorly as apex of first tergum; posterior margin of apical gastral sternum forming a blunt, glabrous point that closes the genital aperture when the genitalia are retracted.

Type locality.—Ft. Collins, Colo.

Types.—U. S. N. M. No. 65750.

Described from 12 ♀ and 37 ♂ specimens, as follows: *Type*, ♀, *allotype*, ♂, Ft. Collins, Colo., sweeping, June 13, 1895, C. F. Baker. *Paratypes*: 7 ♀, 15 ♂, same data as the type; 4 ♂, same data, but sweeping *Carex*, June 20, 1895; 4 ♂, June 28, 1895; 2 ♀, 4 ♂, July 3, 1895; 1 ♂, Aug. 1, 1895; 5 ♂, Aug. 4, 1895; 1 ♀, Campton's, Colo., July 21, 1895, C. F. Baker; 1 ♂, Centennial, Wyo., July 12, 1960, R. J. Lavigne. A single male labeled Iowa, July 1895, and another from Chamber's Lake, Colo., sweeping, July 18, 1895, C. F. Baker, are in poor condition and are not included in the type series.

**Passaloecus turionum Dahlbom, an Adventive  
European Wasp in the United States  
(Hymenoptera, Sphecidae)**

KARL V. KROMBEIN, Entomology Research Division,  
Agr. Res. Serv., U. S. D. A.

Earlier this year I received for identification two *Passaloecus* males reared from a twig in Macomb Co., Michigan, by S. J. Thomas on March 19, 1961. I was unable to identify these positively, though they appeared to be very close to European specimens standing under the name *brevicornis* Morawitz in the U. S. National Museum collection. I sent one specimen to Dr. J. de Beaumont, Musée Zoologique, Lausanne, Switzerland, who reported that it was *turionum* Dahlbom, of which he considers *brevicornis* a synonym. The U. S. specimen differed from Swiss material only in having the tibiae entirely infuscated instead of pale basally. The species seems variable in this regard in the U. S., because some specimens discovered subsequently among unidentified material in the U. S. N. M. do have the tibiae pale at the base.

So far the species is known here from only a few specimens as follows: 2 ♂♂, Macomb Co., Mich., emerged March 19, 1961 (S. J. Thomas); 1 ♂, Rutland, Ohio, July 1953 (W. E. Miller); 1 ♀, near Rockville, Md., October 4, 1947 (H. and M. Townes); 1 ♂ (teneral), Vienna, Va., July 19, 1941 (J. C. Bridwell); and 1 ♀, 1 ♂, Durham, N. C., emerged March 23, 1942, from *Pinus taeda*\* (W. Haliburton, #1837). A native chrysidid, *Omalus iridescens* (Norton) bears the same label data as the last specimen except that it emerged April 1, 1942, and is numbered 1837a; presumably it was reared from a cell of the *Passaloecus*. It is noteworthy that all U. S. specimens of *turionum* were captured during the last 20 years. I was unable to find the species in the extensive older collections of Hymenoptera in the Academy of Natural Sciences of Philadelphia.

*P. turionum* runs to *relativus* Fox in my key to eastern *Passaloecus* (*Bull. Brooklyn Ent. Soc.* 33: 122-123, 1938). It

\* Presumably reared from borings in the bark.



is distinguished from *relativus* by having the mesopleural disk margined anteriorly by a sharp carina and series of foveolae, and by having the male flagellar segments strongly rounded out below except the last two, rather than being weakly rounded out below except for the last three.

---

## A Large Population of *Polistes annularis* (Linn.) (Vespidae, Hymenoptera)

W. V. BALDUF, University of Illinois, Urbana

On October 17, 1950, my attention was attracted by an unusual number of *Polistes annularis* (Linneus) near Oakwood, Champaign County, Illinois. This occurred in the valley of the Salt Fork river in an area that was stripped of its coal about 40 years ago. Separating the river bottom, with its characteristic spoil banks and narrow artificial lakes, from the upland, with its remnant of oak-hickory forest, is an almost sheer cliff approximately 50 feet high, that marks the limit of the stripping operation. In the subsequent years, soil eroding from the cliff wall has accumulated at its base, forming a considerable shoulder on which now grow willow and a few other woody plants typical of shady wet habitats.

On the warm, quiet afternoon of October 17, the sun shone directly upon the face of the sector of the cliff concerned here, and many *P. annularis* flew lazily along the sheer upper three-fourths of the precipice. A smaller number performed likewise along the eastward extension and also to the north of this sector. From my position at the top of the bank, I was able to net a sample consisting of 65 females and 8 males as an occasional one leisurely rose to the rim of the cliff. Thus, the cliff wall was continuously alive with circling, rising, and descending wasps.

The probable source of this local flight was reported to me later by reliable acquaintances, who rowed along the lake at the foot of the cliff. In a distance of about one-half mile, they counted 50 nests of *Polistes* suspended from the then bare small

trees growing on the shoulder of soil a few feet above the water surface. Few nests hung from the oaks and hickories standing on the upland near the rim of the stripped area.

It may be conjectured that the unhurried mass movements of wasps on that sunny afternoon may have been activated by up-drafts of air from the lake to the upland. The destiny of the numerically predominant females was not determined. A suggestion as to the significance of this flight may be taken from the observations of Rau (1941), who identified two types of swarming of *Polistes* wasps in temperate regions—(1) the movements in spring of sometimes large numbers of queens from hibernation to their nesting sites, and (2) flights at the end of summer, when the young queens, recently emerged from the brood nests, swarm into hibernation by slow stages rather than go into it directly. By analogy the flights of *P. annularis* at Oakwood may have represented an early stage of movement toward hibernation.

Since *P. annularis* appears to be selective in its choice of winter sites, a second article from Rau (1930) affords a clue as to the possible destination of the Oakwood wasps. At Cliff Cave, along the Mississippi river, 20 miles south of St. Louis, Rau found this species year after year, hibernating among crevices of the rocky bluffs west of the river, whereas it appeared to nest only among the vegetation in the lowlands east of the river. Again by analogy, the flying young queens of *annularis* observed at Oakwood were possibly on the way to hibernate either in the vegetated spoil banks in the river bottom, or, more likely, in the crevices of the shady cliff walls up and down the river itself.

#### SUMMARY

A large flight of *P. annularis* occurred near Oakwood, Illinois. The wasps originated in nests on trees at the base of a cliff at the edge of a stripmine, and may have been on the way to hibernating sites.

#### REFERENCES CITED

- RAU, PHIL. 1930. *Ann. Ent. Soc. Amer.* 23: 461-466.  
— . 1941. *Ann. Ent. Soc. Amer.* 34: 580-584.

## The Collembola of New Mexico. V. Isotominae: Anurophorus, Isotomodes, Folsomia<sup>1,2</sup>

HAROLD GEORGE SCOTT<sup>3</sup>

Ten species of springtail insects are recorded in this part. All are new records for the state. Specimens will be deposited with the Academy of Natural Sciences, Philadelphia, Pennsylvania.

Family ENTOMOBRYIDAE Tomosvary, 1882

Body elongate, segmented; pronotum reduced, usually membranous and devoid of setae.

Subfamily ISOTOMINAE Schaffer, 1896

Distal antennal segments never annulate; Abd III and IV subequal or terminal abdominal segments ankylosed.

### KEY TO GENERA OF NEARCTIC ISOTOMINAE

- |   |  |
|---|--|
| 1. Anal spines present.....             | 2                                      |
| Anal spines absent.....                 | 6                                      |
| 2. Anal spines 8.....                   | <b>Weberacantha</b> Christiansen, 1951 |
| Anal spines 2 or 4.....                 | 3                                      |
| 3. Anal spines 2.....                   | 4                                      |
| Anal spines 4.....                      | 5                                      |
| 4. Unguiculus present.....              | <b>Biacanthella</b> Scott, 1961        |
| Unguiculus absent.....                  | <b>Uzelia</b> Absolon, 1901            |
| 5. Furcula short, reaching Abd III..... |  |
| .....                                   | <b>Tetracanthella</b> Schott, 1891     |
| Furcula long, reaching Abd I....        | <b>Spinisotoma</b> Stach, 1926         |
| 6. Furcula absent.....                  | <b>Anurophorus</b> Nicolet, 1841       |
| Furcula present.....                    | 7                                      |
| 7. Bothriotricha present.....           | 8                                      |
| Bothriotricha absent.....               | 10                                     |

<sup>1</sup> A portion of a dissertation submitted to the Graduate Faculty of the University of New Mexico, Albuquerque, in partial fulfillment of the requirements for the Degree of Doctor of Philosophy.

<sup>2</sup> Part IV appeared in ENT. NEWS 72: 93-96.

<sup>3</sup> Training Branch, Communicable Disease Center, Public Health Service, U. S. Department of Health, Education, and Welfare, Atlanta, Georgia.

8. Abd V and VI ankylosed... **Archistoma** Linnaniemi, 1912  
 Abd V and VI not ankylosed.....9
9. Mucro with 3-4 teeth..... **Isotomurus** Borner, 1903  
 Mucro with 5 teeth..... **Axelsonia** Borner, 1907
10. Postantennal organ absent..... **Folsomina** Denis, 1931  
 Postantennal organ present.....11
11. Anus ventro-terminal.....12  
 Anus terminal.....13
12. Manubrium with medial hooks.....  
 ..... **Isotomodes** Linnaniemi, 1907  
 Manubrium without medial hooks.. **Folsomia** Willem, 1902
13. Abd IV longer than III.....14  
 Abd IV subequal to or shorter than III.....15
14. Mucro with 0-3 teeth..... **Proisotoma** Borner, 1901  
 Mucro with 4 teeth..... **Metisotoma** Maynard, 1951
15. Mucro with 2 teeth.....16  
 Mucro with 3-4 teeth.....19
16. Eyes absent..... **Micrisotoma** Bellinger, 1952  
 Eyes present.....17
17. Eyes 2 and 2 to 4 and 4..... **Folsomides** Stach, 1922  
 Eyes 8 and 8.....18
18. Body segments bulging with deep intersegmental constrictions..... **Guthriella** Borner, 1906  
 Body segments not bulging; without deep intersegmental constrictions..... **Isotomina** Borner, 1902
19. Unguis tunicate..... **Agrenia** Borner, 1906  
 Unguis not tunicate.....20
20. Dens without spines..... **Isotoma** Bourlet, 1839  
 Dens with spines.....21
21. Mucro with 3 teeth..... **Semicerura** Maynard, 1951  
 Mucro with 4 teeth..... **Tomocerura** Wahlgren, 1900

Genus **ANUROPHORUS** Nicolet, 1841

**Anurophorus laricis** Nicolet, 1841.

This is the only species of *Anurophorus* recorded from North America.

NEW MEXICO RECORDS. Ten collections, 1 under rocks and 9 Berlese samples (from rotten coniferous logs; spruce, fir, yellow pine, and Gambel oak litter, and grass clumps); 7,500 to 13,100 ft, Santa Fe, Mora, San Miguel, Valencia, Torrance, and Lincoln Co.; Jun.-Sept., 1951-1954.

DISTRIBUTION. Colo., Iowa, Minn., N. M., N. Y., Ontario (Canada), Europe, Asia.

Genus *Isotomodes* Linnaniemi, 1907

*Isotomodes tenuis* Folsom, 1937.

This is the only *Isotomodes* recorded from North America.

NEW MEXICO RECORD. From flower pot, apartment, 5,100 ft, Albuquerque, Bernalillo Co., 25-iii-1955.

DISTRIBUTION. Iowa, Mass., N. M.

Genus *FOLSOMIA* Willem, 1902

KEY TO SPECIES OF NEARCTIC *FOLSOMIA*

NOTE. Undue emphasis should not be placed upon the taxonomic significance of eye number. However, this characteristic is used for convenience in the following key, and has been found to be reliable.

1. Mucro 2-toothed.....*guthriei* (Linnaniemi, 1912)
- Mucro 1-toothed.....2
2. Eyes absent.....*candida* Willem, 1902
- Eyes present.....3
3. Eyes 8 and 8.....4
- Eyes fewer than 8 and 8.....6
4. Unguis without teeth.....*elongata* (MacGillivray, 1896)
- Unguis with teeth.....5
5. Manubrium with 1 pair of ventral setae...*prima* Mills, 1931
- Manubrium with many ventral setae...*silvestri* Folsom, 1937
6. Eyes 6 and 6.....*alpina* Kseneman, 1936
- Eyes 5 and 5.....*hoffi* sp. nov.
- Eyes 3 and 3.....*sexoculata* (Tullberg, 1871)
- Eyes 2 and 2.....*quadrioculata* (Tullberg, 1871)
- Eyes 1 and 1.....*diplophthalma* (Axelson, 1902)

*Folsomia alpina* Kseneman, 1936.

NEW MEXICO RECORDS. Three Berlese samples of aspen and fir litter, 8,300 to 10,600 ft, Sept., 1951, Sandia Mts., Bernalillo Co.

DISTRIBUTION: N. M., Europe.

**Folsomia hoffi**, sp. nov. Fig. 1.

TYPE LOCALITY. *Holotype* and 4 *paratypes* from Alpine Zone, Santa Fe Baldy, Santa Fe Co., NEW MEXICO. The type specimens were taken from a Berlese sample of clumps of vegetation, 12,400 ft., 14-vii-1954. Specimens will be deposited with the Academy of Natural Sciences, Philadelphia, Pennsylvania.

DESCRIPTION. Body elongate, not subglobose; segmentation distinct; last 3 abdominal segments ankylosed; integument smooth; light yellow with brown markings; intersegmental areas pale; clothed by short setae, with a few longer setae on the abdomen; head prognathous; ratio of antenna to head 11:13; ratio of antennal segments 4:7:6:12; postantennal organ present, of the simple isotomine types; eyes 5 and 5, each eye on its own dark spot; mouthparts chewing; ratio of body segments 4:16:15/11:12:12:24; distal segment on tibiotarsus present; claws not tunicate; ratio of unguiculus to unguis 1:5; tenent hairs absent; unguis and unguiculus without teeth; furcula without ankylosis; furcula extending to Abd II; ratio of manubrium to dens to mucro as 13:12:2; dental spines absent; dentes dorsally crenulate; mucro with 1 tooth; mucro not lamellate; anus ventro-terminal; anal spines absent; length 1.1 mm.

NOTE: This species is named for Dr. C. Clayton Hoff, Professor of Biology, University of New Mexico, whose diligent collecting made this study possible.

NEW MEXICO RECORDS. Type collection plus Berlese sample of sod, Alpine Zone, 12,000 ft, Lake Peak, Santa Fe Co., 26-vi-1954; and Berlese sample of aspen litter, 8,200 ft, Hyde Park, northeast of Santa Fe, Santa Fe Co., 28-viii-1952.

DISTRIBUTION: N. M.

**Folsomia elongata** (MacGillivray, 1896).

NEW MEXICO RECORDS. Eleven Berlese samples of Alpine vegetation, litter (aspen, aspen-fir, oak, oak-pinon, pinon-juniper, juniper), and rotten conifer logs; 6,400 to 12,000 ft, Santa Fe, Bernalillo, Rio Arriba, and Sandoval Co.; Jan.-Nov., 1950-1953.

DISTRIBUTION. Colo., Ill., Iowa, Kansas, Maine, Minn., N. M.

**Folsomia guthriei** (Linnaniemi, 1912).

NEW MEXICO RECORDS. Two Berlese samples of yellow pine and aspen-fir litter, 7,600 to 9,700 ft, Lincoln and Rio Arriba, Co., Jul.-Aug., 1951-1953.

DISTRIBUTION. Minn., N. M., Europe.

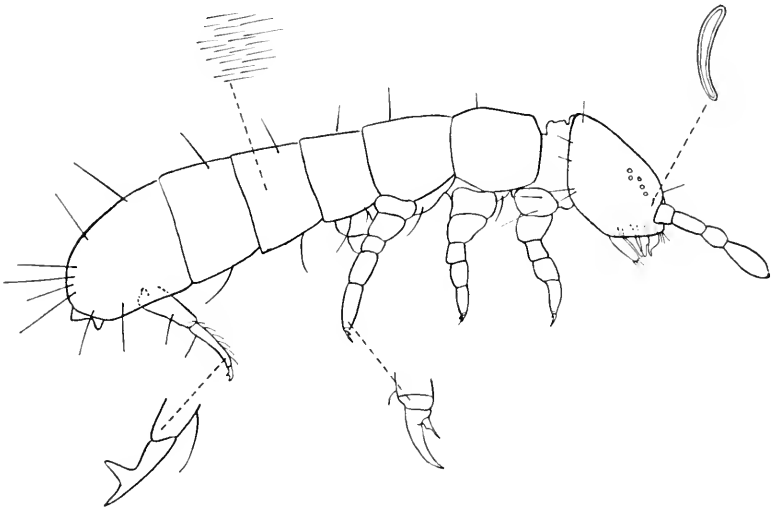

FIG. 1. *Folsomia hoffi* sp. nov., holotype.

**Folsomia nivalis** (Packard, 1873).

NEW MEXICO RECORDS. Four samples (with ants beneath rocks, from rotten log near stream, Berlese samples of aspen-spruce-fir-litter, and of rotten coniferous log), 8,300 to 9,300 ft, Taos, Mora, San Miguel and Bernalillo Co., Jul.-Nov., 1950-1954.

DISTRIBUTION. Maine, N. M., N. Y.

**Folsomia quadrioculata** (Tullberg, 1871).

NEW MEXICO RECORD. Berlese sample of aspen soil and litter, 9,500 ft, Sandia Mts., Bernalillo Co., 16-vi-1951.

DISTRIBUTION. Ill., Minn., N. M., N. Y., Canada, Greenland, Europe, Asia.

**Folsomia sexoculata** (Tullberg, 1871).

NEW MEXICO RECORD. From Berlese sample of aspen soil and litter, 10,000 ft, near Santa Fe Swi Area, northeast of Santa Fe, Santa Fe Co., 12-x-1952.

DISTRIBUTION. N. M., Europe.

**Folsomia silvestri** Folsom, 1937.

NEW MEXICO RECORDS. Two Berlese samples of fir and aspen-fir litter, 9,200 and 10,000 ft, Sandia Mts. Bernalillo Co., July, 1950-1951.

DISTRIBUTION. N. M., N. Y.

## SUMMARY

Record is made of 10 species of isotomine Collembola from New Mexico: *Amurophorus laricis*, *Isotomodes tenuis*, and eight species of *Folsomia* including *F. hoffi* sp. nov. Keys are presented to genera of Nearctic Isotominae and to species of Nearctic *Folsomia*.

## REFERENCES CITED

- ABSOLON, K. 1901. Zool. Anz. 24: 209-216.  
AXELSON, W. M. 1902. Med. Soc. Fauna Flora Fennica 28: 101-111.  
BELLINGER, P. F. 1952. Psyche 59(1): 20-23.  
BORNER, C. 1901. Abh. naturw. Ver. Bremen 17: 1-141.  
———. 1902. Zool. Anz. 25: 605-607.  
———. 1903. Sitz. Ges. naturf. Freunde Berlin, Vol. of 1903: 129-182.  
———. 1906. Mitt. naturh. Mus. Hamburg 23: 147-188.  
BOURLET, A. 1839. Mem. Soc. Sci. Agr. Lille, Part 1: 377-417.  
CHRISTIANSEN, K. A. 1951. Psyche, 58: 24-31.  
DENIS, J. R. 1931. Boll. Lab. Zool. Gen. Agr. Portici 25: 69-170.  
FOLSOM, J. W. 1937. U. S. Natl. Mus. Bull. 168, iii + 144 pp.



- KSENEMAN, N. 1936. Ann. Tschechoslowak Akad., Landw. 11: 210.
- LINNANIEMI, W. M. 1907. Akad. Abhandlung, Helsingfors, 146 pp.
- . 1912. Acta Soc. Sci. Fennicae 40: 1-361.
- MACGILLIVRAY, A. D. 1896. Can. Ent. 28: 47-58.
- MAYNARD, E. A. 1951. The Collembola of New York. Ithaca: Comstock Publ. Co., xxiv + 339 pp.
- MILLS, H. B. 1931. American Mus. Novitates No. 464: 1-11.
- NICOLET, H. 1841. Nouv. Mem. Soc. Helv. Sci. Nat. 6: 1-88.
- PACKARD, A. S. 1873. 5th Ann. Rept. Trust., Peabody Acad. Sci. pp. 23-51.
- SCHAFFER, C. 1896. Mitt. naturh. Mus. Hamburg 13: 147-216.
- SCOTT, H. 1891. Bih. K. Svenska Vet.-Akad. Handl. 17: 1-25.
- SCOTT, H. G. 1961. Ent. News 72: 93-96.
- STACH, J. 1922. Ann. Mus. Nat. Hungarici 19: 1-75.
- . 1926. Bull. Acad. Polonaise Sci. Lett. (B): 579-588.
- TOMOSVARY, O. 1882. Math. Term. Kozlem. Magyar Akad. 18: 119-130.
- WAHLGREN, E. 1900. Ent. Tidskrift 21: 265-270.
- WILLEM, V. 1902. Ann. Soc. Ent. Belgique 46: 275-283.

---

## Coccygomimus maurus (Cresson) in New Jersey (Hymenoptera: Ichneumonidae)

CHARLES C. PORTER, Metuchen, New Jersey

On July 15, 1961, I collected at the Glassworks in Lebanon State Forest, New Jersey, a large and perfect female of *C. maurus*, which was investigating a sapling of *Pinus rigida*. As Townes in his recent monograph of the Ephialtinae (*Bulletin of the United States National Museum* No. 216, Part 2, pp. 321-322) records the species only from Florida, Texas, southeastern North Carolina, and Fairfield County, Ohio, the present capture represents a large, if not entirely unexpected, addition to the species' range, adding another to the list of primarily Lower Austral insects which reach the Pine Barrens of southern New Jersey.

## Notes and News in Entomology

Under this heading we present, from time to time, notes, news, and comments. Contributions from readers are earnestly solicited and will be acknowledged when used.

### Revised International Code Now Ready

It will interest your readers to know that the long-awaited newly revised International Code of Zoological Nomenclature is scheduled for publication the first week of November, 1961, and may be obtained, post free, for one pound sterling upon application to the Publication Office, The International Trust for Zoological Nomenclature, 19 Belgrave Square, London, S.W. 1.

This new revision was commenced at the Paris Congress in 1948, and has since then had incorporated in it the principles laid down in the Opinions of the International Commission on Zoological Nomenclature during the preceding half century, which had come to comprise a formidable body of case-law. It was the subject of close scrutiny by the First International Colloquium on Zoological Nomenclature in Copenhagen, which sat continuously from the 29th of July to the 4th of August, 1953, and was attended by 51 zoologists from some twelve countries. Based on the old code and all the revisionary decisions reached up to that period a new tentative draft code was then prepared and published, as was also an extended bulk of subsequent comment emanating from world-wide sources. All this material came before the Second International Colloquium on Zoological Nomenclature which was held at London in July, 1958, with a membership of approximately 200 zoologists. The ensuing Fifteenth International Congress of Zoology empowered its Commission on Nomenclature to adopt and publish the final wording of a fully revised code, based entirely on the decisions reached by the Colloquium and Congress, except that it was given power to decide a few details which time had prevented from being considered at London. The final wording with editing of the new code was placed in the

hands of a committee of two French, two British and two American zoologists. Their work, the results of which have been adopted by the Commission, has proven most arduous, and has taken many months and even years to accomplish. It included a week's session in London in the spring of 1959.

The Code, in its new guise, forms a volume of almost exactly 200 pages and consists of equivalent English and French texts on facing pages, English and French glossaries, Index, Introduction by Dr. Norman R. Stoll, and a Preface.

J. CHESTER BRADLEY,  
President of the International  
Commission on Zoological Nomenclature

#### Nomenclature Notice

All comments relating to the following should be marked with the Commission's File Number and sent in duplicate, before February 11th, to the Secretary, International Commission on Zoological Nomenclature, c/o British Museum (Natural History, Cromwell Road, London, S.W. 7, England.

Designation of a type-species for **Lygus** Hahn, 1833 (Order Hemiptera). Z.N.(S.) 1062.

Designation of a type-species for **Myodocha** Latreille, 1807 (Order Hemiptera). Z.N.(S.) 1431.

For details see Bull. Zool. Nomencl. Vol. 18, Part 4.

# Entomologist's Market Place

## ADVERTISEMENTS AND EXCHANGES

Advertisements of goods or services for sale are accepted at \$1.00 per line, payable in advance to the editor.

Notices of wants and exchanges not exceeding three lines are free to subscribers.

All insertions are continued from month to month, the new ones are added at the end of the column, and, when necessary, the older ones at the top are discontinued.

---

**Butterflies.** Wish to exchange specimens for Japanese species. Please write to Ichiro Nakamura (Boy, age 16), 26 Aza-Nichiyama Obayashi Takarazuka-shi, Hyogo-Ken, Japan.

**Phasmidae** of nearctic area desired alive. Purchase or trade, drawing on large stock of major orders, worldwide. Domminck J. Pirone, Dept. Entomology, Cornell University, Ithaca, N. Y.

**Nitidulidae and Rhizophagidae** wanted in exchange for European beetles of all families. O. Marek, Zámberk 797, Czechoslovakia.

**Wanted and Needed.** We are compiling a history of entomology, and particularly, at present, of the amateur insect clubs that flourished 50 to 75 years ago. Will you who have knowledge of such early clubs or societies advise me, giving facts on the time of existence, members, etc., which you may have. J. J. Davis, Dept. of Entomology, Purdue University, Lafayette, Indiana.

**Cockroaches (Blattoidea)** of Japan, Okinawa, Formosa (Taiwan), and the Philippines are being studied in cooperation with Dr. K. Princis. Loans of specimens from that area are desired. A. B. Gurney, U. S. National Museum, Washington 25, D. C.

**Orthoptera. Gryllinae** (except domestic sp.) and **Pyrgomorphinae** of the world wanted in any quantity for work in morphology, taxonomy, cytology, and experimental biology; dry, or in fluid, or living. Write D. K. Kevan and R. S. Bigelow, Dept. of Entomology, McGill University, Macdonald College, Quebec, Canada.

**Beetles** of the world wanted, all species in exchange for American beetles, moths and butterflies. James K. Lawton (age 18), 7118 Grand Parkway, Wauwatosa 13, Wisconsin.

## INDEX TO VOLUME LXXII

(\* Indicates new genera, names, etc.)

ALEXANDER, C. P. New exotic crane-flies (Diptera: Tipulidae) Part III .....	113
Part IV .....	235
ALEXANDER, G. The type locality of Gomphocerus Thomas (Orthoptera: Acrididae) .....	107
ARNETT, R. H. The Onychophora of Jamaica .....	213
BALDUF, W. V. A large population of <i>Polistes annularis</i> (Linn.) (Vespidae: Hymenoptera) .....	259
BRADLEY, J. C. The revised International Code of Zoological Nomenclature .....	268
The Vienna Congress .....	46
BURKS, B. D. The species of <i>Pseudometaga</i> Ashmead (Hymenoptera, Eucharitidae) .....	253
CHAMBERLIN, R. V. Notes on the geophilid chilopods of Utah .....	96
COOK, E. F. (See under Meade, A. B.)	
COOPER, K. W. Occurrence of the European pselaphid beetle <i>Trichonyx sulcicollis</i> (Reichenbach) in New York State .....	90
COPPEL, H. C. An unusual habitat niche for <i>Ancistrocerus tigris tigris</i> (Saussure) (Hymenoptera: Vespidae) .....	246
CRABILL, R. E., JR. A catalogue of the Schendylinae of North America including Mexico, with a generic key and proposal of a new <i>Simoporus</i> (Chilopoda: Geophilomorpha: Schendylinae) .....	29, 67
Concerning the Neogeophilidae, with proposal of a new genus. (Chilopoda: Geophilomorpha: Neogeophilidae) .....	155, 177
DENNIS, C. J. An observation of the behavior of <i>Telamona compacta</i> Ball preceding and during oviposition, (Homoptera, Membracidae) .....	152

EADS, D. C. The terminology of phallic structures in the Cyrtacanthacridinae (Orthoptera, Acrididae) .....	141
ELBEL, R. E. (See under Emerson, R. E.)	
EMERSON, K. C. and R. E. ELBEL. A new species of <i>Rallio-</i> <i>cola</i> (Mallophaga) from southeast Asia .....	130
EVANS, H. E. Notes on the nesting behavior of <i>Plenoculus</i> <i>davisi</i> Fox (Hymenoptera: Sphecidae) .....	225
FORD, H. G. (See under Hyland, K. E.)	
FROESCHNER, R. C. Revision of the south African genus <i>Dearcla</i> Signoret with descriptions of three new species (Hemiptera: Cydnidae) .....	197
GERTSCH, W. J. Herbert Ferlando Schwarz, 1883-1960	85
GILLASPY, J. E. A new species of <i>Stictiella</i> from Mexico (Sphecidae: Bembicini) .....	169
HAYS, K. L. <i>Tabanus aranti</i> sp. nov. (Diptera: Tabani- dae) from Alabama .....	127
HUBBARD, C. A. Fleas from the kangaroo rats of northern California .....	133
Host specificity of fleas from kangaroo rats .....	25
HULL, F. M. The genus <i>Psilocurus</i> Loew .....	101
HYLAND, K. E. and H. G. FORD The occurrence of the nasal mite <i>Speleognathopsis bastini</i> Fain (Speleognathi- dae) from the big brown bat, <i>Eptesicus fuscus</i> (Beau- vois) .....	6
JUDD, W. W. <i>Melanagromyza tiliae</i> (Coud.) (Diptera: Agromyzidae) reared from linden bark galls at London, Ontario .....	192
KNOWLTON, G. F. (See under Wray, D. L.)	
KRAMER, J. P. <i>Herpetomonas muscarum</i> (Leidy) in the haemocoel of larval <i>Musca domestica</i> L. ....	165
KROMBEIN, K. V. <i>Passaloecus turionum</i> Dahlbom, an adventive European wasp in the United States (Hymen- optera: Sphecidae) .....	258
Some insect visitors of mat <i>Euphorbia</i> in southeastern Arizona .....	80
V. S. L. Pate, 1903-1958 .....	1

KURCZEWSKI, F. E. New North American records of Pepsinae and Ceropalinae (Hymenoptera: Pompilidae)	24
LINSLEY, E. G. A new rhinotragine cerambycid from Arizona and Sonora (Coleoptera)	163
McDERMOTT, F. A. A new genus and species of firefly: <i>Photocus boliviae</i> (Coleoptera: Lampyridae)	174
McFADDEN, M. W. An improved technique for using the Berlese funnel	150
MEADE, A. B. and E. F. COOK Notes on the biology of <i>Scatopse fuscipes</i> (Meigen) (Diptera: Scatopsidae)	13
MUSSER, R. J. Some noteworthy dragonfly records from Utah (Odonata: Anisoptera)	53
PHILIP, C. B. New North American Tabanidae XIII. Change of name for a well-known species of <i>Chrysops</i>	160
RAPP, W. F. Corrodentia in cliff swallow nests	195
PORTER, C. C. <i>Coccygomimus maurus</i> (Cresson) in New Jersey (Hymenoptera: Ichneumonidae)	267
SABROSKY, C. W. A new Nearctic species of <i>Stenoscinis</i> , with key to the species of the Western Hemisphere (Dip- tera: Chloropidae)	19
Three new nearctic acalyprate Diptera	229
SCHLINGER, E. I. New species of <i>Acrocera</i> from Arizona and <i>Ocnaea</i> from California, with synonymical notes on the genus <i>Ocnaea</i> (Diptera: Acroceridae)	7
SCHMIEDER, R. G. Review: A manual of common beetles of North America	194
Review: Cicindelidae of Canada	223
Review: Facts and theories concerning the insect head	221
Review: Forest and shade tree entomology	55
Review: Western butterflies	223
SCOTT, H. G. Collembola from Japan. Hypogastrurinae and Neanurinae	121
The Collembola of New Mexico. III. Onychiurinae	57
IV. A new genus of Isotominae (Entomobryidae)	93
V. Isotominae: <i>Anurophorus</i> , <i>Isotomodes</i> , <i>Folsomia</i>	261
Mosquitoes: Key to United States genera based on male genitalia (Diptera: Culicidae)	243

SELANDER, R. B. Supplementary records of meloid beetles (Coleoptera) of the West Indies .....	190
SPILMAN, J. T. On the immature stages of the Ptilodactylidae (Coleoptera) .....	105
STAHNKE, H. L. A new species of scorpion of the Vejovidae: <i>Paruroctonus vachoni</i> .....	206
SVIHLA, A. Another record of the larva of <i>Epiophlebia laidlawi</i> Tillyard, (Odonata: Anisozygoptera) .....	66
THRONE, A. L. Psectra diptera (Burmeister) in Wisconsin (Neuroptera: Hermerobiidae) .....	193
TILDEN, J. W. Studies in the genus <i>Ochlodes</i> Scudder. II. The type material of the North American species (Lepidoptera: Hesperiiidae) .....	37
WRAY, D. L. and G. F. KNOWLTON Collembola from rodent nests .....	248



## GENERAL SUBJECTS

Behavior of <i>Telamona</i> .....	152
Berlese funnel method .....	150
Biology of <i>Scatopse fuscipes</i> .	13
Host specificity in fleas ....	25
Insect visitors on mat <i>Euphorbia</i> .....	80
International Code .....	268
International Congress .....	46
International Congress U.I.E.-I.S. ....	27
Mosquito, key to U. S. males .	243
Nesting behavior of <i>Plenoculus</i> .....	225
Nomenclature notices 36, 220,	269
Onychophora of Jamaica ....	213
Phallic structures, terminology of .....	141
Polistes, large population of ..	259
Subscription rates, new ....	166
Symposium announced .....	166

## OBITUARIES

Bischoff, H. ....	132
Calvert, P. P. ....	251
Fulton, B. B. ....	139
Fate, V. S. L. ....	1
Schwarz, H. F. ....	85

## REVIEWS

Books received (Col., Dipt.)	100
Cicindelidae of Canada .....	223
Manual of common beetles ..	194
Snodgrass: Facts and theories of insect head .....	221
Western butterflies .....	223

## GEOGRAPHICAL DISTRIBUTION

Africa: Hemip. ....	197
Alabama: Dipt. ....	127

Arizona: Col. 163; Dipt. 7, 234, Hym. ....	23
Arkansas: Chilop. ....	32
Bolivia: Col. ....	174
California: Dipt. ....	10, 230
Colorado: Hym. ....	257
Guatemala: Chilop. ....	177
India: Dipt. ....	113-121, 235-240
Jamaica: (Onyccoph.) ....	213
Japan: Collembola .....	121
Mexico: Hymn .....	169
Mississippi: Dipt. ....	104
New Mexico: Collembola 62, 64, 264	
North Carolina: Dipt. ....	232
Philippines: Dipt. ....	241-43
Texas: Dipt. ....	102, 103
Thailand: Malloph. ....	131

## COLEOPTERA

<i>aurocineta arizonensis</i> ,* <i>Odonotocera</i> .....	163
<i>boliviae</i> ,* <i>Photocus</i> .....	174
Cicindelidae, of Canada (book)	223
<i>Lytta</i> , monograph .....	100
<i>maculata</i> , <i>Cissites</i> .....	190
Manual of Col. (review) ..	194
<i>marginata</i> , <i>Pseudozonitis</i> ....	191
Meloidae of W. Indies .....	190
<i>Mycophilus</i> .....	36
<i>obscuricornis</i> , <i>Pseudozonitis</i> ..	191
<i>Photocus</i> * .....	174
Ptilodactylidae, immature stages .....	105
<i>punctulata</i> , <i>Nemognatha</i> ....	191
<i>serricollis</i> , <i>Pterodactyla</i> ....	105
<i>sulcicollis</i> , <i>Trichonyx</i> .....	90
<i>vexans</i> , <i>Aedes</i> , <i>illus.</i> .....	245

## DIPTERA

<i>adachiae</i> ,* <i>Stenoscinis</i> .....	22
<i>apoensis</i> ,* <i>Hexatoma</i> .....	240
<i>aranti</i> ,* <i>Tabanus</i> .....	127

<i>artifex</i> ,* <i>Hexatoma</i> .....	118
Biology of <i>Scatopse</i> .....	13
<i>birdi pallustris</i> ,* <i>Psilocurus</i> ..	104
<i>birdi</i> , <i>Psilocurus</i> .....	103
<i>californica</i> ,* <i>Meoneura</i> .....	229
Culicidae, key to U. S. males	243
<i>Dasiops</i> .....	220
Diptera on mat <i>Euphorbia</i> in Arizona .....	83
<i>domestica</i> , <i>Musca</i> , <i>Herpeto-</i> <i>monas</i> in .....	165
<i>dorsalis</i> , <i>Aedes</i> , illus. ....	245
<i>fascipennis</i> , <i>Chrysops</i> .....	160
<i>furtiva</i> ,* <i>Hexatoma</i> .....	239
<i>fuscipes</i> , <i>Scatopse</i> , biology ..	13
<i>geminata</i> ,* <i>Spilochroa</i> .....	233
<i>gnava</i> ,* <i>Hexatoma</i> .....	117
<i>macquarti</i> ,* <i>Chrysops</i> .....	161
<i>madrasensis</i> ,* <i>Hexatoma</i> ....	113
Meigen names, suppression of	36
<i>melanogaster</i> ,* <i>Aerocera</i> ....	10
<i>modestus</i> , <i>Psilocurus</i> .....	104
<i>nudiusculus</i> , <i>Psilocurus</i> .....	104
<i>Ocnaea</i> , notes .....	7
<i>perlongata</i> ,* <i>Hexatoma</i> .....	114
<i>phaeton</i> ,* <i>Hexatoma</i> .....	238
<i>prolixa</i> ,* <i>Hexatoma</i> .....	235
Psychodidae .....	100
Psychodidae of Connecticut ..	100*
<i>punctipennis</i> , <i>Anopheles</i> , illus.	245
<i>pygmaeus</i> ,* <i>Psilocurus</i> .....	101
<i>quinquefasciatus</i> , <i>Culex</i> .....	245
<i>reinhardi</i> , <i>Psilocurus</i> .....	104
<i>rossiana</i> ,* <i>Hexatoma</i> .....	242
<i>serena</i> ,* <i>Hexatoma</i> .....	236
<i>Stenoscinis</i> , key to .....	21
<i>tibialis</i> ,* <i>Psilocurus</i> .....	102
<i>tiliac</i> , <i>Melanagromyza</i> .....	192
<i>unicittatus</i> , <i>Chrysops</i> .....	160
<i>vamana</i> ,* <i>Hexatoma</i> .....	116
<i>voekerothi</i> ,* <i>Pholeomyia</i> ....	231
<i>vulpes</i> ,* <i>Hexatoma</i> .....	119
<i>wiedemanni</i> , <i>Chrysops</i> .....	161
<i>xuthogaster</i> ,* <i>Ocnaea</i> .....	8

## HEMIPTERA

<i>associatus</i> <i>Chlamydatus</i> .....	227
<i>capensis</i> ,* <i>Dearcla</i> .....	200
<i>Dearcla</i> , revision of .....	197
<i>Euceraphis</i> .....	36
<i>lineolaris</i> , <i>Lygus</i> .....	227
<i>Lygus</i> .....	269
<i>Myodocha</i> .....	269
<i>natalensis</i> ,* <i>Dearcla</i> .....	201
<i>opercularis</i> , <i>Dearcla</i> .....	202
<i>paucivillosa</i> , <i>Dearcla</i> .....	204
<i>quercicola</i> , <i>Phytocoris</i> .....	227
<i>ruficornis</i> , <i>Trigonotylus</i> .....	227

## HOMOPTERA

<i>Aphis</i> .....	220
Behavior of <i>Telamona</i> .....	152
<i>Cicadella</i> .....	220
<i>compacta</i> , <i>Telamona</i> .....	152

## HYMENOPTERA

<i>annularis</i> , <i>Polistes</i> .....	259
<i>bakeri</i> ,* <i>Pseudometaga</i> .....	256
<i>coarctata</i> , <i>Ponera</i> .....	91
<i>davisi</i> , <i>Plenoculus</i> , nesting be- havior .....	225
<i>dentipes</i> , <i>Monodontomerus</i> ..	248
<i>evansi</i> ,* <i>Sticticlla</i> .....	169
<i>Lestis</i> .....	220
List of visitors on mat <i>Eu-</i> <i>phorbia</i> in Arizona .....	80
<i>lophyri</i> , <i>Agrothercutes</i> .....	248
<i>maurus</i> , <i>Coccygomimus</i> .....	267
Pompilidae, new records ....	24
<i>Pseudometaga</i> , rev. of .....	253
<i>sehvarzii</i> , <i>Pseudometaga</i> ....	255
<i>similis</i> , <i>Diprion</i> , cocoon use by <i>Ancistrocerus</i> .....	246
<i>tigris</i> , <i>Ancistrocerus</i> , habitat niche .....	246
<i>turionum</i> , <i>Passalococcus</i> .....	258

**LEPIDOPTERA**

- Ochlodes*, type material of *N.*  
 Amer. species ..... 37  
 Western butterflies (book) .. 223

**ORTHOPTERA**

- clavatus*, *Aeropedellus* ..... 107  
*clavatus*, *Gomphocerus*, type  
 locality of ..... 107  
 Terminology of phallic struc-  
 tures ..... 141

**ODONATA**

- armata*, *Oploaeschna* ..... 53  
*laidlawi*, *Epiophlebia* ..... 5, 66  
*Larva* of *Epiophlebia* ..... 66  
*mendax*, *Brechmorhoga* ..... 53  
 Records from Utah ..... 53

**SMALLER ORDERS**

- armata*, *Hypogastrura* (Col-  
 lem.) ..... 121  
*atopus*, *Arctogeophilus* (Col-  
 lem.) ..... 96  
*bostrychophilus*, *Liposcelis*  
 (Corrod.) ..... 195  
 Collembola from Japan .... 121  
 Collembola of New Mexico  
     57, 93, 261  
 Collembola from rodent nests 248  
 Corrodentia ..... 195  
*cunningi*, *Meringis* (Siph.)  
     27, 133  
*dipodomys*, *Meringis* (Si-  
 phon.) ..... 27  
*dipodomys*, *Meringis* (Siph.) 134  
*diptera*, *Psectra*. (Neurop.) .. 193  
*Folsomia* (Collem.) key .... 263  
*glyptus*, *Brachygeophilus* (Col-  
 lem.) ..... 97  
*Harrisoniella* (Malloph.) .... 220  
*hesperus*, *Stenophilus* (Col-  
 lem.) ..... 99

- hoffi*,\* *Folsomia* (Collem.) .. 264  
*hoffmani*, *Thrassis* (Siph.) .. 133  
*indicus*,\* *Rallicola* (Malloph.) 130  
 Isotominae (Collem.) key .. 261  
*japonica*,\* *Hypogastrura* (Col-  
 lem.) ..... 122  
*microps*, *Dipodomys* (Siph.) . 133  
*neomexicana*,\* *Biacanthella*\*  
 (Collem.) ..... 94  
*neomexicana*,\* *Tullbergia*  
 (Collem.) ..... 64  
 Onychiurinae (Collem.), key ... 57  
*Onychiurus* (Collem.) keys,  
 records ..... 58, 60  
*ornata*, *Neamura* (Collem.) .. 124  
*parkeri*, *Meringis* (Siph.) .. 133  
*Perla* (Plecop.) ..... 36  
*pseudornata*,\* *Neamura* (Col-  
 lem.) ..... 124  
*robusta*,\* *Hoffia*\* (Collem.) .. 62  
 Siphonaptera host specificity . 25  
*Tullbergia* (Collem.), key .. 63  
*unguiculatus*, *Rallicola* ..... 132

**NON-HEXAPODA****ACARINA**

- bastini*, *Speleognathopsis* .... 6

**SCORPIONIDA**

- vachoni*,\* *Paruroctonus* ..... 206

**CHILOPODA**

- arcanus*,\* *Simoporus* ..... 32  
*Cryptostrigla* ..... 156, 189  
*dampfi*, *Nyctunguis*, notes on 76  
*ethopus*, *Escaryus* ..... 69  
*Evalllogeophilus* ..... 189  
 Geophilids from Utah ..... 96  
*Holitys*, notes on ..... 71  
 Neogeophilidae ..... 155  
 Neogeophilidae, review of ... 187  
*Neogeophilus* ..... 189

Schendylinae, catalogue and key to genera .....	29, 67
<i>silvestri</i> ,* <i>Cryptostrigla</i> *	157, 177
<i>Simoporus</i> , key to .....	31

**ONYCOPHORA**

Onychophora of Jamaica .....	213
<i>insularis clarki</i> ,* <i>Epiperipatus</i>	215
<i>lewisi</i> ,* <i>Epiperipatus</i> .....	218
Onychophora, keys to .....	214

**NON-ARTHROPODA**

Birds ( <i>Petrochelidon</i> ) .....	195
Plants ( <i>Euphorbia</i> ), insects on	80
Protoza ( <i>Herpetomonas mus-</i> <i>carum</i> ) .....	165
Rodents ( <i>Microtus</i> , <i>Neotoma</i> , <i>Thomomys</i> ), Collembola from nests .....	249
( <i>Dipodomys</i> ), fleas from	25, 133
( <i>Eptesicus</i> ), mite from ....	6

## Pacific Insects

A quarterly journal on the systematic entomology and zoogeography of the Pacific, East Asia, Australia and Antarctica.

Vols. 1-3 (over 500 pages per volume) each \$5.00  
Vol. 4 (1962) (over 700 pages) \$7.00

## Pacific Insects Monographs

Adjunct series appearing irregularly and not included in subscription. To be ordered separately or standing order placed.

- 1A. **The Chrysomelidae (Coleop.) of China and Korea.** Part I. By Gressitt and Kimoto. 299 pp., 75 figs. \$4.00
2. **Problems in the Zoogeography of Pacific and Antarctic Insects.** By Gressitt, with appendices by Maa, Mackerras, Nakata, and Quate. 128 pp., 40 figs. (incl. 2 color pls.). Bound, \$2.50. Paper, \$2.00

---

## Important Mosquito Works

**MOSQUITO ATLAS.** Part I. The Nearctic Anopheles, important malarial vectors of the Americas, and *Aedes aegypti* and *Culex quinquefasciata*

**MOSQUITO ATLAS.** Part II. The more important malaria vectors of the Old World: Europe, Asia, Africa and South Pacific region

By Edward S. Ross and H. Radclyffe Roberts

Price, 60 cents each (U. S. Currency) with order, postpaid within the United States; 65 cents, foreign.

---

### KEYS TO THE ANOPHELINE MOSQUITOES OF THE WORLD

With notes on their Identification, Distribution, Biology and Relation to Malaria. By Paul F. Russell, Lloyd E. Rozeboom and Alan Stone

Mailed on receipt of price, \$2.00 U. S. Currency. Foreign Delivery \$2.10.

---

For sale by the American Entomological Society, 1900 Race Street, Philadelphia 3, Pa., U. S. A.

Just Published

**MEMOIRS OF THE AMERICAN  
ENTOMOLOGICAL SOCIETY**

Number 17

**A TAXONOMIC STUDY OF THE  
MILLIPED FAMILY SPIROBOLIDAE  
(DIPLOPODA: SPIROBOLIDA)**

By William T. Keeton

147 pages of text, 37 tables, 2 maps, 18 plates,  
table of contents and index

Spirobolid millipeds are probably the most widely known Diplopoda in the United States, being used in many college courses; yet the family has been little studied. This monograph brings together existing knowledge of the group for the first time, and adds much new information gained from critical study of series. The taxonomic history of the family is outlined. External morphology is briefly treated, with emphasis on characters utilized in classification. A summary of current knowledge of life histories is included. The family is redefined, and each genus and species is treated in detail. Particular attention is given to variation and distribution, both of which become more meaningful biologically as a result of synonymizing many species names. Possible phylogenetic relationships of the genera are discussed, and keys to all taxa are provided, with most diagnostic characters illustrated in 18 plates or summarized in 37 tables.

Price \$5.50

---

**THE AMERICAN ENTOMOLOGICAL  
SOCIETY**

1900 Race Street, Philadelphia 3, Penna., U.S.A.









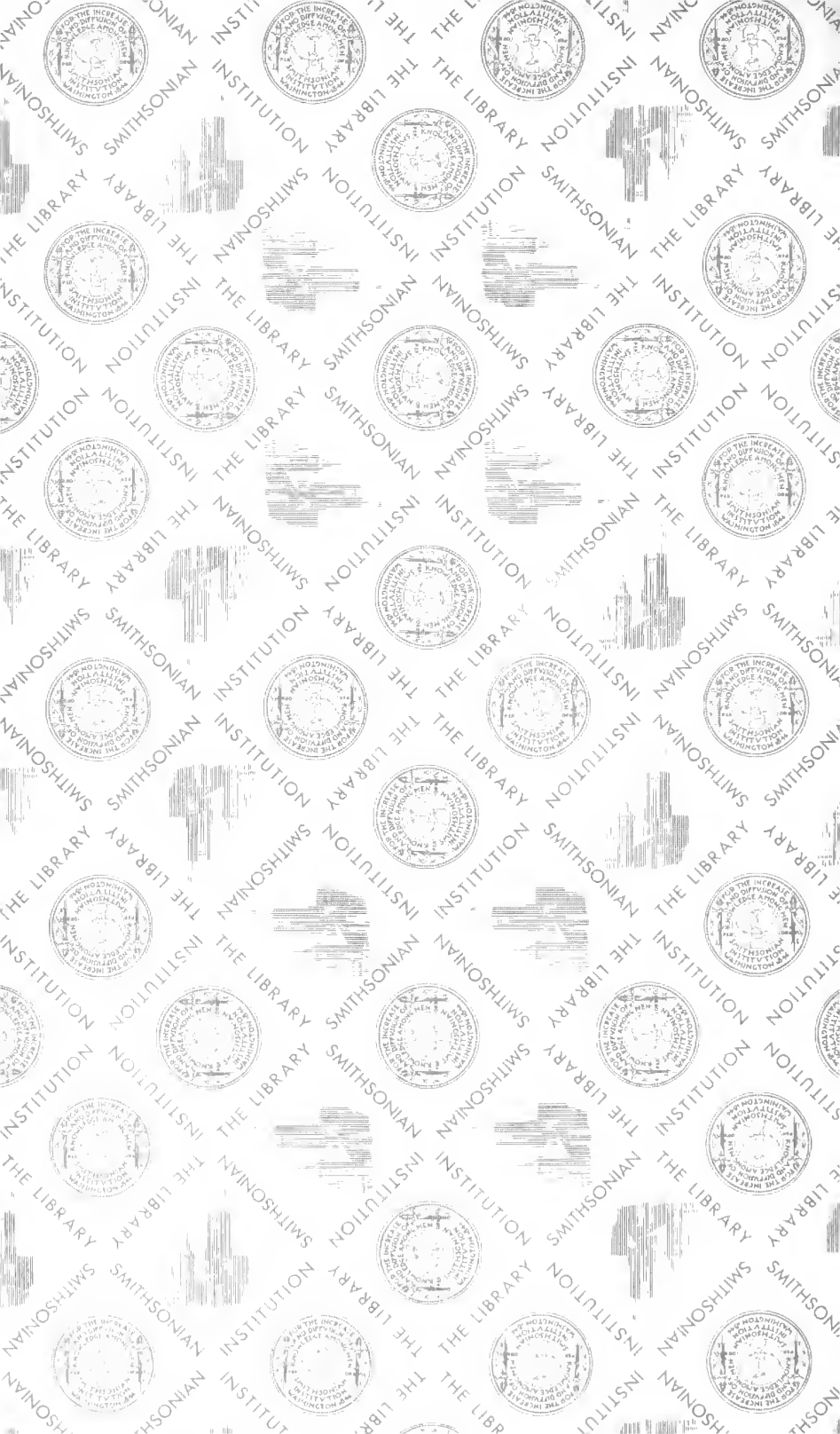

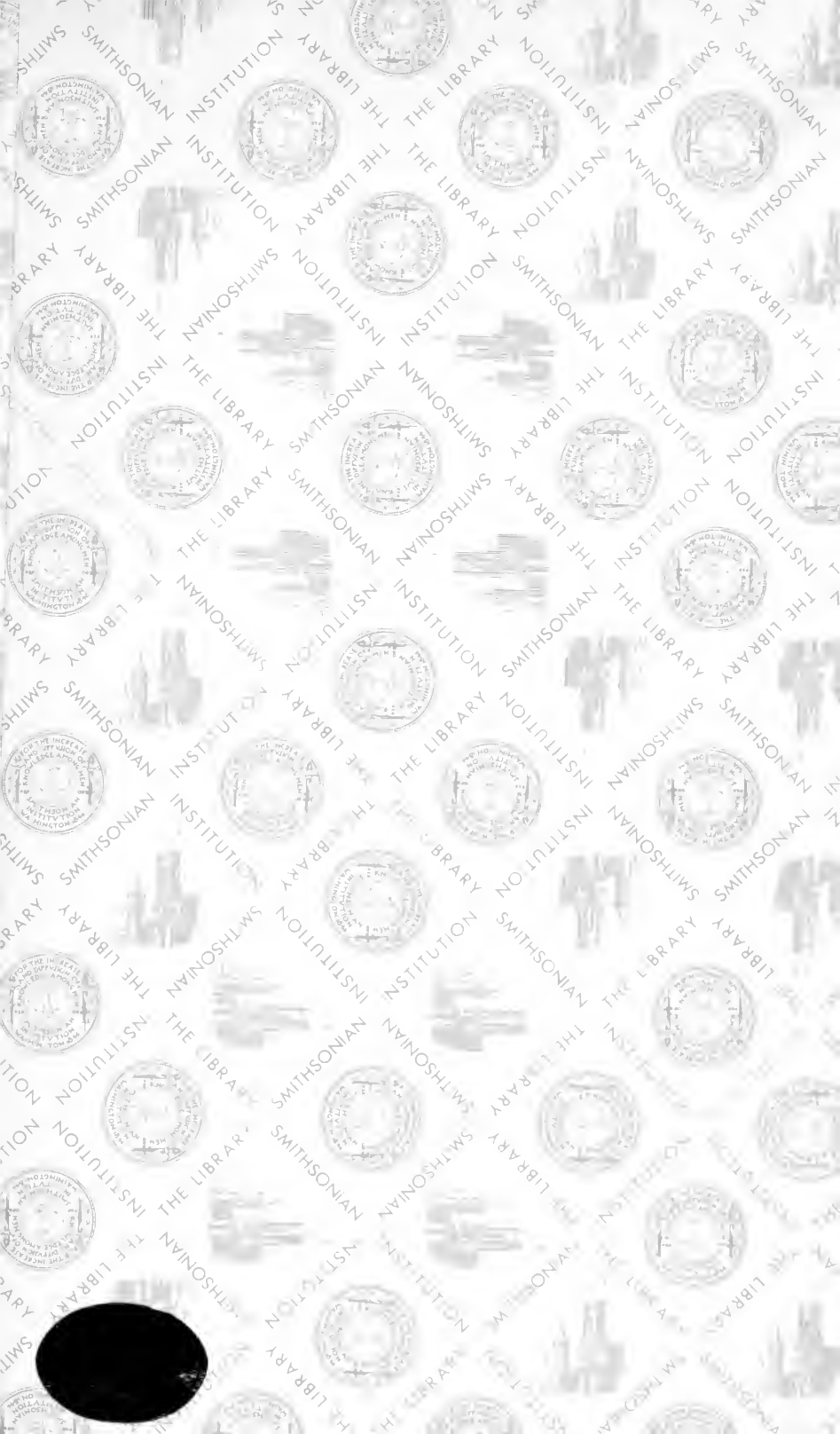

SMITHSONIAN INSTITUTION LIBRARIES



3 9088 00844 5587