



Class S 411

Book F 2

COPYRIGHT DEPOSIT



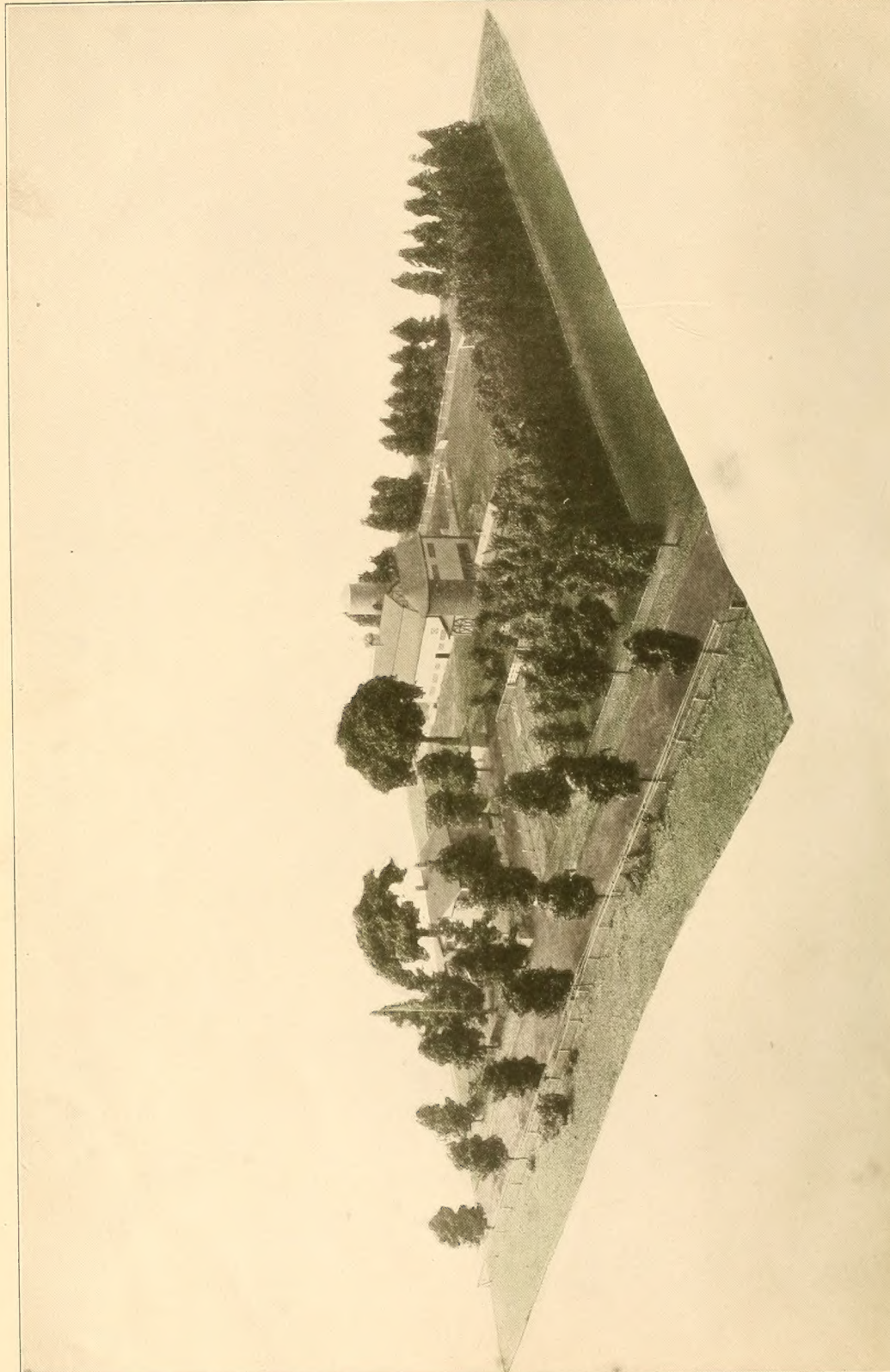

FARM ECONOMY

A Cyclopedia of
Agriculture for the Practical
Farmer and His Family

INCLUDING

*Seed Selection, Soils and Soil Fertility, The Garden and
the Orchard, Concrete on the Farm, Drainage, Dry
Farming, Irrigation, Farm Building Plans,
Weeds, Insects, Pests and Diseases, Farm
Mechanics, Business Methods and
Co-operation*

WITH

A Special Department on Labor Saving
Methods for the Housewife

SPECIAL EDITION

Volumes I, II, III, IV, V, VI, VII, VIII, IX, X, XI Combined in One

EDITORIAL STAFF

SEED SELECTION AND STORAGE,

SPECIAL POINTERS ON CROPS,

R. A. Moore, Professor of Agronomy, Wisconsin

SOILS AND SOIL FERTILITY,

H. L. Walster, M. A., Assistant Professor of
Soils, Wisconsin

THE GARDEN AND THE ORCHARD,

J. G. Moore, M. S., M. H., Professor of Horti-
culture, Wisconsin

CONCRETE CONSTRUCTION,

A. M. Bull, Assistant Professor of Farm Struc-
tures, Minnesota

FARM DRAINAGE, DRY FARMING AND IRRI- GATION,

E. R. Jones, M. S., Associate Professor of
Soils, Wisconsin and E. C. Parker, B. S.
Agr., formerly Agricultural Expert for Govern-
ment of Manchuria.

FARM BUILDINGS,

J. B. Davidson, B. S., M. S. A., Professor of
Agricultural Engineering, Iowa

WEEDS,

H. L. Bolley, Plant Pathologist, North Dakota

INSECT PESTS AND PLANT DISEASES,

C. W. Howard, B. A., M. S., Division of Ento-
mology and E. C. Stakman, Ph. D., Assistant
Plant Pathologist, Minnesota

FARM MECHANICS,

Raymond Olney, Editor of "Farm Engineering"

BUSINESS SIDE OF FARMING,

L. D. H. Weld, Ph. D., Professor of Business
Administration, Yale University.

LABOR-SAVING DEVICES FOR THE HOUSE- WIFE,

Edna R. Richards.

Fully Illustrated with Colored Plates, Engravings, Plans and Charts

Published by

H. L. BALDWIN PUBLISHING COMPANY

MINNEAPOLIS, MINN.

1915

FARM ECONOMY

S411
F21

COPYRIGHT, 1915
BY
H. L. BALDWIN PUBLISHING COMPANY

~~\$6.00~~

JUL -6 1915
©ClA406974
no,

4462
6197

INTRODUCTION

The once common expression, "anybody can farm," which carried with it the idea that farming is muscular activity only, is being used less and less each year. The great majority of farmers now believe that knowledge is power.

"There are three classes of farmers," says Dean Davenport of the Illinois State College of Agriculture, "one class studies experiments, originates; another class emulates the success of the originator, imitates his methods, and in time learns to go to first sources for information; a third class has little faith in 'book learning,' and misunderstanding success, will neither imitate nor learn. The whole tendency of modern times is to make farming so difficult a calling and to so raise the standard of competition, that the third class will be crowded to the wall and be forced into the poorest lands."

It is for the class that puts brain into the management of the farm that FARM ECONOMY has been published. We appreciate the fact that the farmer is a busy man and has not the time to read all the theories connected with the many subjects in which he is interested. 20

Therefore, we have endeavored to give the reader in a concise form the results of scientific research. We will suppose for illustration the case of a farmer who has heard of the germination test for seed corn and who would like to try it but who has no one to show him how to go about it. Naturally he spends a great deal of time devising a method and at the end his results are not dependable. He decides that testing seed corn is a foolish waste of time and never tries it again. If this farmer had a reference book giving him a few simple instructions illustrated by photographs, the test would become an easy task with accurate, reliable results. The weak, infertile ears would be discarded, the corn yield increased, and the farmer become a convert to modern methods.

There are many other things the farmer wants to do. He wants to treat his seed grain for smut, increase the fertility of his soil, conserve the barnyard manure, sweeten his sour land, drain some part of his farm, get rid of the insect pests and weeds in his orchards and fields, arrange his barns conveniently for chores, be able to run a gas engine, splice a hay rope, test milk and cream, keep his books and mix concrete. The farmer's wife would like to know a great many things also; how to lighten household labors, how to can fruit on a large scale to sell, how to plan a pretty flower garden. All these questions and more are keenly interesting to the farmer and his wife.

It is to answer these needs that FARM ECONOMY has been written. FARM ECONOMY not only tells how but accompanies all instructions with illustrating photographs that make the directions easy. The farmer will no longer need to leave undone the many things he knows should be done for want of knowing how.

The title FARM ECONOMY is the keynote of every page of the book. When the American farmer loses over \$825,000,000 through careless handling of farm manure, when weeds alone do damage to the amount of \$100,000,000 (enough to pay all our taxes), when insects destroy \$1,000,000,000 worth of crops each year, when each ear of seed corn that fails to grow means a loss of from five to seven dollars, then it is time that the farmer inform himself on how to prevent these losses. To help the farmer save and make money is the honest purpose of this book.

We are largely indebted to the agricultural colleges and experiment stations throughout the United States for their hearty co-operation and assistance in the preparation of this volume. We wish to express our sincere thanks and appreciation to the following universities for their courtesy in loaning us photographs, half-tones, electrotypes, sketches, and plans: Minnesota, Wisconsin, North Dakota, Iowa, Ohio, Illinois, New York, Montana, Michigan, Maine, Rhode Island, Kentucky, and Nebraska. We are also indebted to the assistance of the Experiment Stations of Missouri, New Hampshire, Louisiana, Kansas, Utah and Texas.

The Departments of Agriculture of the United States and of the Dominion of Canada have aided us by permitting the use of certain of their illustrations and colored plates.

We are indebted to the courtesy of John Wiley & Sons for furnishing electrotypes.

We wish to express our thanks to the Minnesota State Art Society for plans furnished us for "The Farmhouse."

Grateful acknowledgement is also made to the International Harvester Company, to the Universal Portland Cement, The Atlas Portland Cement, The Lehigh Portland Cement Companies and the Association of American Cement Manufacturers for cuts and plans so courteously given to us.

To the American farmer, the backbone of the Nation, the one man without whom our country could not survive, whose labors are long and unceasing, whose dollars are honestly earned, this book is respectfully dedicated, in the hope that it may lighten his labors, increase his profits and awaken new pride in his calling.

THE PUBLISHERS.

TABLE OF CONTENTS.

BOOK I—SEED SELECTION AND STORAGE

CHAPTER I

THE REMOVAL OF WEED-SEED, CHAFF AND LIGHT-WEIGHT GRAIN

- I—Introduction. II—Why Light-Weight Seed Should Be Removed. III—Why Weed Seeds Should Be Removed. IV—Why Chaff Should Be Removed. V—Some Methods of Removal—The Fanning Mill—The Adherence Method—Screening—Hand Screening. VI—Conclusion..... 27

CHAPTER II

THE SELECTION OF SEED

- I—Introduction. II—Danger Signals—Discoloration—Light Weight—Damage. III—Mixtures. IV—Conclusion..... 32

CHAPTER III

THE TREATMENT OF SEEDS FOR SMUT

- I—Nature of Smut. II—Prevention—Crop Rotation—Chemical Treatment of Seed Before Planting. III—Stinking Smut of Wheat—Treatment by Hand—Smut Machines. IV—Oat Smut. V—Loose Smut of Wheat—Treatment. VI—Barley Smut. VII—Corn Smut..... 34

CHAPTER IV

ROTATION AS A MEANS OF BLIGHT-CONTROL

- I—Introduction. II—Principle of Rotation. III—Some Profitable Rotations. IV.—Precautions in the Use of Straw-Manures..... 41

CHAPTER V

TREATMENT TO EXTERMINATE INSECTS FROM GRAIN

- I—Why Grain Insects Should Be Exterminated. II—How Grain Becomes Infested With Insects. III—Preventive Measures. IV.—Treatment to Destroy Insects—Moth Trap—Fumigation—Sulphur—Hydrocyanic Acid Gas—Carbon Bisulphide. 45

CHAPTER VI

STORING GRAIN

- I—The Principles of Grain Storage. II—Construction of the Bins. III—Location of the Bins. IV—Time to Store Grain. V—Some Precautions in Storing Grain. 50

CHAPTER VII

TESTING SEEDS FOR GERMINATION

- I—Why Test for Germination. II—The Principles Underlying the Germination Test. III—Home Germination Tests—Seed-Table for Germinating Tests—Blotting Paper Test—Number of Seeds to Test—Cotton Flannel Test—Table for Time of Tests—Interpreting the Test. IV—The Box-Tester. V—Value of Comparative Tests. VI—Conclusion..... 53

BOOK II—SPECIAL POINTERS ON CROPS

CHAPTER I

CORN

- Part I—The Selection of Seed-Corn. I—The Judging of Corn—Signs of Poor Germination—Signs of Immaturity—Marks of Weakness. II—Curing and Storing—Ways of Stringing—The Corn-Tree. III—Testing Seed Corn—The Sawdust Box Test—"Rag Doll." Part II—Cultivation of Corn. I—Plowing. II—Depth to Plow. III—Planting. IV—Depth to Plant. V—Checking. VI—Cultivation. VII—Harvesting. VIII—Rotations..... 61

CHAPTER II

WHEAT

- I—Soils. II—Preparing the Seed-Bed—Plowing—Fallowing—Treatment After Plowing. III—Seed. IV—Planting—Time—Depth—Amount of Seed to Sow—Method of Sowing. V—Spring Culture. VI—Harvesting—Time—Shocking—Threshing. VII—Fertilizers. VIII—Rotation..... 79

CHAPTER III

OATS

- I—Seed Selecting. II—Preparation of the Seed-Bed. III—Planting—Method—Rate of Seeding—Depth—Time. IV—Cultivation. V—Harvesting. VI—Rotation. 86

CHAPTER IV

BARLEY

- I—The Soil. II—Preparation of Seed-Bed. III—Rotation. IV—Testing and Sowing Seed. V—Cultivation. VI—Harvesting—Sweating..... 89

CHAPTER V

RYE

- I—Soils. II—Preparation of Seed-Bed. III—Sowing the Seed. IV—Cultivation and Care. V—Harvesting. VI—Rotation..... 92

CHAPTER VI

SORGHUM

- I—The Soil. II—The Site. III—Preparation of the Seed-Bed. IV—Planting—Depth—Amount of Seed—Time. V—Cultivation. VI—Harvesting..... 94

CHAPTER VII

SUGAR CANE

- I—Soils. II—Fertilizers. III—Seed-Cane—Storing. IV—Soil Preparation. V—Planting. VI—Cultivation. VII—Harvesting..... 97

CHAPTER VIII

COTTON

- I—Soils. II—Preparation of Seed-Bed—Depth to Plow—Fertilizers. III—Planting—Time—Methods—Depth. IV—Cultivation. V—Picking. VI—Grading and Marketing. VII—The Selection of Seed—The Late Cotton Plant—The Early Cotton Plant. VIII—The Improvement of Cotton—Structure of Flower—Cross Fertilizing the Cotton Flower..... 101

CHAPTER IX

CLOVER

- I—Soil. II—Preparation of the Seed-Bed—Inoculation. III—Planting—Depth—Time—Amount of Seed to Sow. IV—Testing Clover Seed. V—Cutting—for Hay—for Seed. VI—Harvesting Seed. VII—Storing Clover. VIII—Rotation. 110

CHAPTER X

ALFALFA

- I—Seed Selection—Germination. II—Selection of the Field. III—Correcting Acid Soils. IV—Inoculation. V—The Seed-Bed. VI—Planting—Depth to Plant—Method of Planting—Time of Planting. VII—Fallowing. VIII—Cultivation. IX—Storage..... 115

CHAPTER XI

POTATOES

- I—Soil. II—Rotation. III—Manuring. IV—Commercial Fertilizers. V—Fertilizer Tests. VI—Preparation of the Seed-Bed. VII—Planting—Time—Depth—Amount of Seed. VIII—Cultivation. IX—Harvesting. X—Storage. XI—The Selection of Seed Potatoes..... 123

CHAPTER XII

SUGAR BEETS

- I—The Soil. II—Preparation of the Seed-Bed. III—Manuring. IV—Planting—Amount of Seed—Depth—Time—Treatment of Seeds After Planting. V—Cultivation—Thinning—Late Cultivation. VI—Harvesting. VII—Selection of Beets for Seed..... 132

CHAPTER XIII

THE SOY BEAN

- I—The Seed. II—Preparation of Seed-Bed. III—Inoculation. IV—Planting—Time—Method—Spacing—Amount of Seed. V—Cultivation. VI—Harvesting. VII—Storage. VIII—Rotation..... 136

CHAPTER XIV

TIMOTHY

- I—The Soil. II—Preparation of Seed-Bed. III—Seed Selection. IV—Planting—Depth—Amount of Seed. V—Sowing Mixtures. VI—Manures—Barnyard—Lime—Commercial Fertilizers. VII—Cultivation. VIII—Time to Cut. IX—Harvesting. X—Improvement of Timothy—The Clonal Test Plat..... 142

CHAPTER XV

CANADIAN FIELD PEAS

- I—Soil and Climate. II—Fertilizing and Rotation. III—Preparing the Soil. IV—Sowing the Seed. V—Harvesting the Seed Crop—Storing—Threshing. VI—Harvesting the Hay Crop. VII—Varieties. VIII—Diseases and Pests. IX—Uses of the Field Pea..... 147

CHAPTER XVI

FLAX

- I—Soils and Fertility. II—Climate Conditions. III—Diseases and Pests. IV—Seed Selection and Treatment. V—Crop Rotation. VI—Preparation of Seed-Bed. VII—Seeding. VIII—Irrigating Flax. IX—Harvesting—Threshing. X—Uses—Flax on New Land..... 151

BOOK III—SOILS AND SOIL FERTILITY

CHAPTER I

COMPOSITION OF SOILS

- I—Introduction. II—The Fertility of Soils—Necessary Elements for Plant Growth. III—How to Determine Special Elements Required—Soil Analysis—Field Observation. IV—Deficient Elements—Nitrogen—Phosphorus—Potassium. V—Effect of Character of Previous Crops—Tables No. 1 and 2 for Plant Food Removed by Crops. VI—Texture of Structure of Soils—Clay—Sandy—Peat—Loam. VII—Tests by Fertilizer. VIII—Practical Methods of Testing Soils for Acidity and Alkalinity—Litmus Paper Test—The Ammonia Test—Lime Test..... 161

CHAPTER II

THE TREATMENT OF SOILS FOR ACIDITY AND ALKALINITY

- Part I—Practical Treatment of Alkali Soils. Part II—Treatment of Acid Soils. I—Effect of Lime Upon the Soil—Corrects Acidity—Makes Phosphorus and Potassium Available—Improves Physical Condition—Favorable to Bacterial Activity. II—Harmful Effects of Liming. III—Time and Frequency of Application. IV—Lime Compounds—Which Forms to Use—Cost—Table No. 3 Showing Comparative Prices—Amount to Apply—Kind to Use for Different Crops—Rapidity of Action—Fineness of Division—Convenience of Handling and Spreading. V—Crops Benefited by Liming..... 171

CHAPTER III

APPLICATION OF FARM MANURES

- I—Composition of Barnyard Manures—Table No. 4—Showing Percentage of Plant Food Constituents in Fresh Animal Excretions—Table No. 5—Showing Composition of Dried or Free From Water Excrements. II—Importance of Good Care of Manure to Preserve its Value—Nitrogen Losses from Leaching—Table No. 6—Losses of Fertilizing Elements in Horse and Cow Manures—Table No. 7—Losses in Manure from Leaching—Importance of Nitrogen—Bedding as a Means of Conserving Plant Food—Composting as a Means of Conserving Plant Food—Commercial Fertilizers for Conserving Plant Food. III—Methods of Use and Value of Farm Manures—Table No. 8—Approximate Value of Plant Food—Table No. 9—Plant Food Constituents Produced Annually in Excrements of Farm Animals—Organic Matter Is Increased—Plant Food Is Made Available—Effect Is Long Continued—Table No. 10—Gain in Yield of a Manured Plot over Unmanured—Manure in Relation to Different Crops—Manure in Relation to Different Soils. IV—Amount, Time and Frequency of Manure Application—Table No. 11—Plant Food Removed in Three Years' Rotation. V—Relation of Farming and Soil Fertility—Table No. 12—Replacing Fertility by Feeding Wheat Bran—Table No. 13—Effect of Style of Farming on Fertility..... 179

CHAPTER IV

THE VALUE OF GREEN MANURING

- I—Effects of Green Manuring—Organic Matter is Added—Nitrogen is Added. II—Green Manure Crops—Leguminous—Red Clover—Mammoth Clover—Alsike Clover—Field Peas—Sweet Clover—Hairy Vetch—Non-Leguminous—Useful in Orchards. III—The Use of Green Manures—Soils Must be Limed—Relation to Different Soils and Climate—Effect on Succeeding Crops..... 193

CHAPTER V

COMMERCIAL FERTILIZERS

- I—When They Should Be Used. II—Selection of Fertilizers—Table No. 14—Cost of Nitrogen in Different Materials—Table No. 15—Cost of Phosphorus in Different Materials—Table No. 16—Cost of Potassium in Different Materials—Table No. 17. III—Determining Need of Fertilizers by Experiments. IV—The Use of Commercial Fertilizers as Preservatives—Table No. 18—Gain per Ton by Reinforcing Manure with Commercial Fertilizers..... 201

CHAPTER VI

CONTROL OF GENERAL SOIL CONDITIONS

- I—Conserving Moisture of Soils—Value of Organic Matter—Table No. 19—Power of Soils to Hold Water—Table No. 20—Snyder's Experiment—Effect of Cultivation in Moisture Conservation—Table No. 21—Effectiveness of Different Depths of Cultivation. II—Control of Soil Blowing. III—Washing of Soils..... 205

BOOK IV—THE GARDEN AND THE ORCHARD

CHAPTER I

THE FARM VEGETABLE GARDEN

- I—Location. II—Soil. III—Cultivation and Tools. IV—The Hotbed. V—Planning

The Garden. VI—Selection of Varieties. VII—Sowing Seed. VIII—Controlling Weeds. IX—Storing. X—Canning Vegetables. XI—Insects and Fungous Enemies. XII—Classification of Crops—Root Crops—Cole Crops—Foliage Crops—Solanaceous Crops—The Legumes—Vine Crops—Perennial Vegetables. XIII—Quantity of Seed Required..... 211

CHAPTER II

THE FLOWER GARDEN

I—Introduction. II—Uses of Flowers—In House Borders—In Shrub Borders—On the Lawn—As Separate Gardens. III—Care of Flowering Plants—Soil—Preparation of Soil—Planting and Sowing Seed—Starting Annuals—Care of Flowers. IV—Kinds of Plants—Herbaceous Perennials—Annuals—Bulbs—Dahlia—Canna—Annual Vines—Shrubs..... 228

CHAPTER III

PLANTING THE COMMERCIAL ORCHARD

I—Selecting the Site—Soil—Subsoil—Elevation—Exposure. II—Planting the Orchard—Square System—Quinquex—Alternate—Hexagonal. III—Distance of Planting—Table for Number of Trees per Acre—Use of Fillers. IV—Laying Out the Orchard—Wire Methods—Lining-in Method—Marking With the Plow—Staking for Hexagonal System—Method of Locating Trees. V—Selecting Trees for Planting—Ages of Trees—How to Determine Age of Trees—Height of Head—Distribution and Number of Branches. VI—Pointers in Ordering Nursery Stock—Direct Dealing with Nurserymen—State Character of Trees Desired—Keep Copy of Order—Pay a Good Price. VII—Care of Trees on Arrival. VIII—Time for Planting. IX—Setting the Trees—Size of Hole—Root Pruning—Root Distribution—Slant of Tree in Planting—Filling the Hole—Fertilizing—Watering—Mulching. X—Top-Pruning Young Trees—Cutting Back the Top. 243

CHAPTER IV

THE MANAGEMENT OF A BEARING ORCHARD

I—Handling the Orchard Soil. II—Soil Management of Bearing Orchards—As a Pasture—As a Hay or Grain Field—The Sod Mulch—The Half-Sod Mulch—The Clean-Culture-Cover-Crop System—When to Sow Cover Crops—Cover Crops as Plant Food Suppliers—Hardy and Non-Hardy Cover Crops—Amount of Seed for Cover Crops. III—Soil Care in the Young Orchard. IV—Fertilization of the Orchard. V—Pruning the Bearing Orchard—The Time to Prune—Second Season's Pruning—Third Year Pruning. VI—Pruning Neglected Trees—Spasmodic Pruning. VII—Wounds, Their Making and Treatment. VIII—Spraying..... 266

CHAPTER V

STRAWBERRIES AND BUSH FRUITS

I—*Strawberries*—Plants—Location—Soil—Preparation of Land—Time to Plant—Planting—Winter Protection—Renewing Bed—Picking and Marketing—Staminate and Pistillate Flowers—Varieties. II—Bush Fruits—*Raspberries*—Types—Soil and Location—Preparation and Fertilization of Soil—Time to Plant—Getting Plants—Planting—Cultivation—Pruning and Thinning—Tying, Staking, Trellising—Winter Protection—Harvesting and Marketing—Varieties—Pests—*Blackberries* and *Dewberries*—Treatment—Varieties—*Currants*—Plants—Planting—Cultivation—Pruning and Thinning—Harvesting and Marketing—Varieties—*Gooseberries*—Treatment—Varieties—Pests..... 286

BOOK V— CONCRETE CONSTRUCTION

CHAPTER I

CONCRETE AND ITS CONSTITUENTS

I—Advantages of Concrete. II—Portland Cement. III—Aggregates—Sand—Washing Sand—Gravel. IV—Natural Mixture of Bank Sand and Gravel. V—Water..... 305

CHAPTER II

GENERAL INSTRUCTIONS FOR MIXING AND PLACING CONCRETE

- I—Proportioning the Mixture—Rich Mixture—Standard Mixture—Medium Mixture—Ordinary Mixture. II—Measuring the Proportions—Table—The Measuring Box. III—How to Mix Concrete by Hand—First Method—Second Method. IV—Consistency of Mixture. V—Coloring—Tables of Colors. VI—Placing and Protection of Concrete. VII—Reinforcing..... 311

CHAPTER III

MAKING THE FORMS

- I—Materials. II—Requirements of a Good Form. III—Plans for Forms. IV—Selection of Lumber. V—How to Clean and Prevent Concrete from Sticking. VI—Tools and Other Apparatus..... 324

CHAPTER IV

THE CONSTRUCTION OF CONCRETE FLOORS, WALLS AND OTHER PAVEMENTS

- I—Uses of Concrete on the Farm. II—Advantages of Concrete for Floors, Walls, etc. III—Preventing Upheaval and Scaling. IV—Sidewalk Construction—One-Course Work—Two-Course Work—Excavation and Preparation of Subgrade—The Sub-Foundation—Details of Construction—Placing. V—The "Alternate Slab" Method VI—Allowing for Expansion. VII—Table of Materials for 100 Square Feet of Concrete. VIII—Floors and Other Pavement—Preventing Slipperiness. 328

CHAPTER V

THE CONSTRUCTION OF PIERS, FOUNDATIONS AND WALLS

- I—Foundations—Concrete Block and Poured Concrete—Forms—Concrete Mixture. II—Piers. III—Table for Basement Wall Construction. IV—Walls—Bolts in Foundation—Improving Appearance of Wall..... 336

CHAPTER VI

THE CONSTRUCTION OF TANKS, TROUGHS AND CISTERNS

- I—Watering Tanks or Troughs—Construction of a Circular Tank—Construction of an Oblong Tank. II—Hog Troughs. III—Milk and Cream Vat. IV—Manure Pits—Shallow and Deep Pits—The Sink Hole—Side Hill Construction. V—Cisterns—Thickness of the Walls. VI—Septic Tanks—Sewage Dangers—Construction of Septic Tank..... 342

CHAPTER VII

THE CONSTRUCTION OF STEPS AND CELLARWAYS

- I—Casting Steps in Separate Moulds. II—Monolithic Construction. III—Wall and Stair Forms Built Together..... 353

CHAPTER VIII

FENCE POSTS AND STUCCO WORK

- I—Concrete Fence Posts. II—Table for Materials in Making Six-Post Batch. III—Stucco—Uses for—Application—Coloring..... 356

 BOOK VI—FARM DRAINAGE, DRY FARMING
AND IRRIGATION

PART I—FARM DRAINAGE

CHAPTER I

PLANNING A DRAINAGE SYSTEM

- I—Introduction. II—Benefits of Drainage—Excessive Water Is Injurious—Drainage Increases Land Values. III—Planning Drainage System—To Determine the Grade—Farmers Can Do Their Own Surveying—Method of Survey.... 363

CHAPTER II

SUB-SURFACE DRAINAGE

I—Methods of Drainage. II—Location of Drains. III—Outlets. IV—Amount of Drainage Needed—Depth of Tile—Diameter of Tile and Gradient Slope—Table for Capacity of Drains—Distance Between the Laterals. V—Digging the Trench and Grading. VI—The Tile and Its Laying. VII—Filling the Trenches. 370

CHAPTER III

COST AND PROFIT OF TILE DRAINAGE

I—Will It Pay?—Table for Price of Tile—Table for Cost of Digging and Laying. II—Drainage Projects..... 379

CHAPTER IV

SURFACE DRAINAGE

I—Ease and Cheapness of Construction. II—Methods of Construction. III—Surface Runs in Conjunction With Sub-Drains. IV—Cost of Maintenance. V—The Farmer as a Drainage Engineer..... 384

PART II—DRY FARMING

CHAPTER I

SOIL MOISTURE FOR DRY FARMING

I—Introduction—Extent of Dry Farming Regions—Definition and Limitations—Early Experimental Evidence. II—Soil Moisture—Conservation Essential—Sources of Water—In the Soil—Amount of Capillary Water—Movement of Capillary Water—Losses of Water—Amount Required for Crops—Table No. 1—Table No. 2—Table No. 3—Widtsøe's Rules..... 388

CHAPTER II

TILLAGE OPERATIONS

I—Theory of the Dirt Mulch. II—Packing the Soil. III—Importance of Plowing. IV—Time of Plowing. V—Depth of Plowing. VI—Disk Plowing. VII—Subsoiling or Deep Tillage. VIII—Disking Stubble Ground Before Plowing. IX—Tillage After Plowing. X—Value of a Compact Seed-Bed. XI—Inter-Tillage..... 394

CHAPTER III

MANAGEMENT OF DRY FARMING CROPS

I—Field Crops—General Nature—Wheat—Oats and Barley—Rye, Emmer or Speltz—Corn—Sorghums—Flax—Potatoes—Millet—Alfalfa—Sweet Clover—Brome Grass—Sudan Grass—Dakota Vetch. II—Principles of Crop Rotation. III—Live Stock. IV—The Summer Fallow. V—Trees and Shrubs..... 407

CHAPTER IV

DRY FARMING MACHINERY

I—Plows. II—Harrows. III—Weeders. IV—Cultivators. V—Packers. VI—Seeders—Table No. 4—Amount and Depth of Seeding for Dry Land Crops. VII—Harvesters..... 417

CHAPTER V

HINTS TO THE DRY LAND FARMER

I—Amount of Rainfall—Type of Soils—Size of Farm. II—Ten Commandments of Dry Farming..... 424

PART III—IRRIGATION

CHAPTER I

INTRODUCTION

I—The Carey Act. II—The Reclamation Act. III—Water Rights. IV—Value of Water..... 427

CHAPTER II

SOURCES OF IRRIGATION WATER

- I—Streams. II—Springs. III—Storage Reservoirs. IV—Pumping Plant. V—Pumping from Wells. VI—Motive Power..... 430

CHAPTER III

LOSSES OF IRRIGATION WATER

- I—Loss in Storage Reservoirs. II—Loss in Canals. III—Effect of Different Linings or Seepage. IV—Advantages of Concrete Lining. V—Loss in Dead Ditches and Laterals. VI—Loss in the Field. VII—Percentage Losses of Water Diverted. 434

CHAPTER IV

MEASUREMENT OF WATER

- I—Standards of Measurement. II—The Cippoletti Weir. III—The Weir Box or Flume—Table No. 1—Weir Dimensions. IV—Permanent Construction of Measuring Devices. V—Rules for Setting Weirs. VI—Causes Affecting Accuracy of Measurement. VII—Formula for Computing Water Flow—Table No. 2. 439

CHAPTER V

SELECTION AND PREPARATION OF LAND FOR IRRIGATION

- I—Choice of Land. II—Clearing the Land. III—Preparing the Seed-Bed. IV—Ditch Construction. V—Structures for Water Distribution—Siphons—Flumes. VI—Head Ditches. VII—Waste Ditches..... 449

CHAPTER VI

METHODS OF WATER DISTRIBUTION

- I—Overhead Sprays. II—Sub-Irrigation. III—Irrigation by Flooding. IV—Flooding by Flowing Sheet of Water. V—Flooding Diked Land with Standing Water. VI—Border Irrigation. VII—Furrow Irrigation—Irrigation of Potatoes by Furrow Method. VII—Details of Irrigation—Conclusion..... 455

BOOK VII—FARM BUILDINGS

CHAPTER I

THE FARMSTEAD

- I—The Site. II—Arrangement of Buildings—Rectangular System. III—Placing Individual Buildings. VI—Conclusion..... 467

CHAPTER II

THE FARM HOUSE

- I—Introduction. II—Location. III—Style of Architecture. IV—Exterior Finish. V—Interior Arrangement. VI—Plans. VII—Construction..... 470

CHAPTER III

THE DAIRY BARN

- I—Introduction. II—Barn Plans—Well Arranged Barn—Inconvenient Barn—Convenient, Sanitary Barn. III—Details of Construction—Floors—Ceilings—Ventilation—Lighting—Stalls—Bull Pen—Water Supply—Manure Pits. IV—The Round Dairy Barn—Advantages of—Details of Construction—Explanatory Plates—Floors—Ventilation—Lighting—Stalls 481

CHAPTER IV

SILOS

- I—Introduction. II—Location. III—Size. IV—Hoop Silo—Roofs. V—Stave Silo—Difficulties of Building—Methods of Erection—Doors—Reinforcing—The Roof—Guy Wires. VI—Vitrified Block Silos—Selection of Blocks—Devices of Construction—Foundation—Doors—Reinforcement—The Roof—Washing. VII—The

Cement Block Silo. VIII—Solid Cement Silo—The Mixture—Foundation—Reinforcing the Roof. IX—The Pit Silo—Location—Construction—Removing Silage. X—Tables for Silo Construction..... 508

CHAPTER V

THE BEEF CATTLE FARM

I—Plans—No. 1—With Central Feeding Alley—No. 2, No. 3—With Open Shed. II—Requirements of Good Barns..... 536

CHAPTER VI

THE HORSE BARN

I—Introduction. II—Arrangement—Plan No. 1. III—Details of Construction—Floors—Ceilings—Lighting—Ventilation—Walls—Stalls 540

CHAPTER VII

THE COMBINATION BARN

I—Requirements. II—Plans—No. 1, No. 2, No. 3..... 543

CHAPTER VIII

THE HOG HOUSE

I—Permanent Hog House—Site—Arrangement—Plan No. 1—Plan No. 2—Details of Construction—Floor—Overlay—Pens—Farrowing Pen—Windows—Doors—Walls—Roofs—Yard. II—Movable Hog House—The "A Shaped"—"Shed-Roof"—Troughs—Conclusion 547

CHAPTER IX

THE POULTRY HOUSE

I—The Site. II—Permanent Poultry House—Plan—Details of Construction—Floors—Walls—Roof—Lighting—Ventilation—Lofts—Partitions—Roosts—Dropping Boards—Nests—Feeding Devices—Drinking Devices—Dust-Bath—Long House—Yards. III—Movable Poultry House—Small Flock Laying House—Brooder House Incubators 560

CHAPTER X

THE SHEEP BARN

I—Essentials. II—Location. III—Plain. IV—Details of Construction—Partitions—Doors—Feeding Racks—Pens..... 575

CHAPTER XI

THE GRANARY

I—Location. II—Types—Two Story—Metal—Elevator—Plan for Elevator—Elevator—Construction—Cost—Advantages of Elevator..... 578

CHAPTER XII

THE POTATO WAREHOUSE

I—Requirements. II—Types. III—Plans—No. 1—Basement Type—Specifications—Elevating System—No. 2—For Storage on a Large Scale—Specifications—Hot Air Furnace. VI—Co-operative Potato Warehouse..... 581

CHAPTER XIII

THE ROOT CELLAR

I—Materials. II—Site. III—Temperature. IV—Ventilation. V—Drainage. VI—Handling Contents. VII—Plans—No. 1, No. 2, No. 3..... 589

CHAPTER XIV

THE MACHINE SHED

I—Importance of Caring for Farm Machinery. II—Location of Shed. III—Interior Arrangement 592

CHAPTER XV

PROTECTION FROM LIGHTNING

- I—Principle of Protection. II—Parts of Protection System—Points—Rods—Ground.
 III—Construction of System..... 595

CHAPTER XVI

PAINTS AND PAINTING

- I—Composition of Paints. II—Drying of Paint. III—Utensils for Painting. IV—
 Mixing. V—Painting—Painting Iron—Repainting. VI—Care of Brushes. VII
 Precautions. VIII—Costs. IX—Conclusion..... 598

BOOK VIII—WEEDS

CHAPTER I

NATURE AND KINDS OF WEEDS

- I—Introduction. II—Classification. III—Annuals—Biennials—Perennials. IV—
 Methods of Reproducing and Spreading..... 603

CHAPTER II

METHODS OF ERADICATING ANNUAL AND BIENNIAL WEEDS

- I—Introduction. II—Treatment for Small Areas—Use of Tar Paper—Pulling Stray
 Plants—Cutting Plants With "Spud" or Hoe. III—Methods for Large Patches
 Spraying—Iron Sulphate—Salt Solution—Cultivation—Rotation of Crops—
 Destroy Weeds in Waste Places..... 606

CHAPTER III

THE MOST TROUBLESOME ANNUAL AND BIENNIAL WEEDS AND METHODS FOR THEIR
 ERADICATION

- I—French Weed—Description—Eradication. II—Wild Oats—Description—Eradica-
 tion. III—Wild Mustard—Description—Eradication. IV—Russian Thistle—De-
 scription—Eradication. V—Chess. VI—Annual Sow Thistle..... 613

CHAPTER IV

GENERAL METHODS OF ERADICATING PERENNIAL WEEDS

- I—Introduction. II—Digging and Removing Roots, Bulbs, etc. III—Treatment With
 Salt, Acids and Other Chemicals. IV—Root Starvation. V—Exposure to Action
 of Sun, Wind and Frost. VI—Smothering Weeds by Crop Growth. VII—Per-
 sistent Work Essential..... 620

CHAPTER V

THE MOST NOXIOUS PERENNIAL WEEDS AND METHODS FOR THEIR ERADICATION

- I—Quack Grass—Description—Eradication—Pure Seed Laboratories. II—Canada
 Thistle—Description—Eradication—Eradication in Small Patches. III—Peren-
 nial Sow Thistle or Milkweed—Description—Eradication. IV—Ox-Eye
 Daisy. V—Wild Barley. VI—Conclusion..... 625

CHAPTER VI

CONDITIONS WHICH TEND TO BRING ABOUT WEEDY CONDITIONS OF LAND

- I—Introduction. II—Winter Drifting of Seed. III—Effect of Drainage. IV—Seed
 Contamination—Seed Adulteration. V—Distribution of Seed and Forage Stuff.
 VI—Buried Weed Seed. VII—Barnyard Manures, Compost Heaps as Sources
 of Weed Distribution. VIII—Parasitic Disease—Fungous Diseases. IX—Sum-
 mary of Information for Recognition of Weeds..... 636

BOOK IX — INSECT PESTS AND PLANT DISEASES

PART I — INSECT PESTS

CHAPTER I

THE INSECT DANGER AND GENERAL MEANS OF CONTROL

- I—Insect Injury to Crops. II—Results from Insect Control. III—Value of the Knowledge of Insects. IV—Natural Enemies of Insects. V—Farm Methods of Control. VI—Insecticides—Poisons—Contact Insecticides—Fumigants—Repellents. . . . 651

CHAPTER II

INSECTS WHICH INJURE GRAIN AND GRASS CROPS

- I—White Grubs. II—Wireworms. III—Cutworms. IV—Army Worm. V—Fall Army Worm. VI—Chinch-Bug. VII—Grasshoppers and Locusts. VIII—Hessian Fly. IX—Wheat Joint-Worm. $\frac{1}{8}$ —English Grain-Louse. 657

CHAPTER III

INSECTS INJURIOUS TO CORN

- I—Corn-Root Aphid. II—Western Corn Root-Worm. III—Seed-Corn Maggot. IV—The Corn Ear-Worm. 674

CHAPTER IV

INSECTS INJURIOUS TO STORED GRAINS

- I—Grain Weevils. II—Grain Beetles. III—Flour and Meal Moth. IV—Angoumois Grain Moth. 679

CHAPTER V

INSECTS INJURIOUS TO CLOVER

- I—The Clover Root-Borer. II—The Clover Leaf Weevil. III—The Clover-Seed Midge. VI—The Clover-Seed Chalcid. 682

CHAPTER VI

INSECTS INJURIOUS TO POTATOES AND TOMATOES

- I—Potato Stock-Borer. II—The Stock Borer. III—Colorado Potato Beetle. IV—Blister Beetles. 685

CHAPTER VII

INSECTS INJURIOUS TO BEANS AND PEAS

- I—The Pea Weevil. II—The Common Bean Weevil. III—Blister Beetles. IV—The Pea-Aphid. 690

CHAPTER VIII

INSECTS INJURIOUS TO BEETS AND SPINACH AND CABBAGE

- I—The Sugar Beet Web-Worm. II—Blister Beetles. III—The Cabbage Maggot. IV—The Imported Cabbage Worm. 693

CHAPTER IX

INSECTS INJURIOUS TO MELONS, CUCUMBERS, SQUASH, ETC.

- I—The Striped Cucumber Beetles. II—The Squash-Bug. 697

CHAPTER X

INSECTS INJURIOUS TO MISCELLANEOUS GARDEN CROPS

- I—The Pale-Striped Flea-Beetle. II—The Tarnished Plant-Bug. III—The Celery or Greenhouse Leaf-Tyer. IV—The Celery Caterpillar. V—The Imported Onion Maggot. VI—The Asparagus-Beetle. 701

CHAPTER XI

INSECTS INJURIOUS TO THE STRAWBERRY

- I—The Strawberry Root-Louse. II—The Strawberry Crown-Borer. III—The Strawberry Leaf Roller. VI—The Strawberry Weevil. 705

CHAPTER XII

INSECTS INJURIOUS TO RASPBERRIES, BLACKBERRIES, CURRANTS AND GOOSEBERRIES

- I—The Raspberry Root-Borer. II—The Raspberry Cane-Borer. III—The Snowy Tree-Cricket. IV—The Raspberry Sawfly. V—The Raspberry Byturus. VI—The Imported Currant-Borer. VII—The Flour-Lined Leaf-Bug. VIII—The Currant Aphis. IX—The Imported Currant Worm. X—The Native Currant Worm 710

CHAPTER XIII

INSECTS INJURIOUS TO GRAPES

- I—The Grape Cane-Borer. II—The Grapevine Flea-Beetle. III—The Rose-Chafer. IV—Hawk Moth Larvæ. V—The Grape-Berry Moth. VI—The Grape Curculio. 715

CHAPTER XIV

SOME INSECTS INJURIOUS TO ORCHARD FRUITS

- I—San José Scale. II—The Buffalo Tree-Hopper. III—The Periodical Cicada. IV—The Fall Webworm. V—The Brown-Tail Moth. VI—The Gypsy Moth. VII—The Canker Worms—VIII—The Plum Curculio. IX—The Plum Gonger. 719

CHAPTER XV

INSECTS INJURIOUS TO APPLE AND PEAR

- I—The Woolly Apple-Aphis. II—The Round-Headed Apple-Tree Borer. III—The Flat-Headed Apple-Borer. VI—The Oyster-Shell Scale. V—The Scurvy Scale. VI—Apple Plant-Lice. VII—The Tent Caterpillar. VIII—The Yellow-Necked Apple Caterpillar. IX—The Red-Humped Apple Caterpillar. X—The Apple Leaf-Miner. XI—The Pistol Case-Bearer and the Cigar Case-Bearer. XII—The Bud Moth. XIII—The Codling Moth. XIV—The Apple Maggot or "Railroad Worm." XV—The Pear Slug..... 730

CHAPTER XVI

INSECTS INJURIOUS TO COTTON AND TOBACCO

- I—Hornworms or Tobacco-Worms. II—The Mexican Cotton Boll Weevil. 741

CHAPTER XVII

CONTROL OF FLIES IN RURAL DISTRICTS

- I—The Fly as a Disease Carrier. II—Disposal of Manure. III—Care of Garbage. IV—Outhouses. V—Screening..... 744

CHAPTER XVIII

BIRDS AS INSECT DESTROYERS

- I—Economic Value of Birds to the Farmer—Estimate of Insects Consumed by Birds Daily in Massachusetts. II—Insect-Destroying Capacity of Birds—Amount of Food Required by Young Birds—By Adult Birds. III—Good Services of Birds—Trees and Crops Saved From Destruction by Birds—Increase of Insects Following Destruction of Birds—Birds as Destroyers of Hairy Caterpillars and Lice—Services of Birds in the Orchard—Weed Seeds Consumed by Birds—Birds as Rodent Killers—Birds as a Sanitary Force. IV—The Enemies of Birds. V—Birds as Pests. VI—How to Attract Birds—Winter—Spring—Summer—Fall—Table No. 1—Birds to Attract for Policing Different Vegetations—Table No. 2—Guide for Placing Nesting Places..... 748

PART II—PLANT DISEASES

CHAPTER I

DISEASES OF CEREAL CROPS

- I—Wheat—Rust—Smut—Treatment for Bunt—Treatment for Loose Smuts—Seedling Diseases—Scab. II—Oats—Rust—Smut—Blade Blight or Blast—Seedling Diseases. III—Barley—Rust—Smut—Stripe Diseases—Rye—Rust—Smut—Ergot. IV—Corn—Smut. V—Flax—Rust—Wilt..... 762

CHAPTER II

DISEASES OF THE POTATO, ALFALFA AND CLOVER

- I—Potato—Early Blight—Late Blight—Tip Burn—Fusarium Wilt—Rosette, Rhizoctonia—Blackleg—Scab—Rots—General Suggestions for the Prevention of Potato Diseases. II—Alfalfa—Leaf Spots—Wilt—Anthracnose—Pseudomonose. III—Clover—Rust—Anthracnose—Black Mould—Wilt—Leaf Spots..... 777

CHAPTER III

DISEASES OF ORCHARD AND GARDEN CROPS

- I—Orchard Crops—General Statement—Preparation of Bordeaux Mixture—Lime Sulphur—Precaution in Spraying *Apple*—Scab—Black Rot—Bitter Rot—Rust—Fire Blight—Cankers. *Plum* and *Cherry*—Brown Rot—Plum Pockets—Shot Hole. II—Small Fruits. *Raspberry*—Anthracnose—Cane Blight—Crown Gall—Yellows—Rust—Leaf Spot. *Blackberry*, *Strawberry*—Leaf Spot. *Gooseberry*—Powdery Mildew—Leaf Spot. *Currant*—Leaf Spot. *Grapes*—Downy Mildew—Black Rot—Powdery Mildew. III—Garden and Truck Crops. *Bean*—Anthracnose—Blight—Powdery Mildew—Stem Rot. *Tomato*—Black Rot—Point Rot—Leaf Spot. *Cucumbers*—Wilt—Nubbin. *Cabbage*—Black Rot—Club Root—Yellows. *Pea*—Leaf Spots—Powdery Mildew—Soft Rot of Vegetables..... 788

BOOK X — FARM MECHANICS

PART I—THE FARM GAS ENGINE

CHAPTER I

ITS MANAGEMENT AND APPLICATION FOR FARM POWER PURPOSES

- I—Introduction—Power on the Farm—Power Machinery Increases Man's Production Capacity—Farmer Uses Most Gas Engine Horse-Power. II—Uses for Gas Engine—How It Was First Used—In the Dairy—The Farmwife's Helper—Using a Line Shaft—Portable Power Plant. III—Farm Machines That a Gas Engine Will Run 805

CHAPTER II

WHAT IS A GAS ENGINE?

- I—Why Called Internal-Combustion Engine—Two Misconceptions of Term "Gas Engine." II—Chemical Process of Burning—Need of Electric Spark. III—Parts of Engine and Their Relation to Its Operation—How Energy Is Stored Up in Flywheel—Accessories to the Engine Proper..... 812

CHAPTER III

PRINCIPLES OF GAS ENGINE OPERATION

- Difference Between Four-Cycle and Two-Cycle Engines. I—How the Four-Cycle Engine Operates. II—Suction, Compression, Expansion and Exhaust Events. III—How the Two-Cycle Engine Operates—Two-Port Engine—Three-Port Engine. IV—Difference Between Two-Cycle and Four-Cycle Engines. 815

CHAPTER IV

HOW POWER IS PRODUCED IN THE GAS ENGINE

PART I—CARBURETION

- I—How Mechanical Power Is Developed—Expansive Force of Burning Fuel—Losses of Heat—Amount of Heat Energy Converted Into Useful Work. II—Carburetion—Requirements—Carbureting Process—Getting the Proper Mixture. III—Lean and Rich Mixtures—Cause—Symptoms—Remedies. IV—Carburetors vs. Mixing Valves 822

PART II—COMBUSTION

- I—Combustion Defined. II—Composition of Fuels. III—Process of Combustion. IV—What Takes Place in the Cylinder. V—Reason for Time of Ignition. VI—Rapidly of Combustion. VII—Cooling and Pre-Ignition 825

CHAPTER V

FUELS FOR FARM GAS ENGINES

- I—Requirements of a Good Fuel. II—Kinds of Fuel—How They Are Obtained—Differences. III—Composition of Crude Oils. IV—How Petroleum Fuels Are Produced—Commercial Gasoline—Kerosene. V—Classification of Petroleum—Fuels by Weight—Comparative Table—Baume Scale. VI—Changes in Gravities of Petroleum Fuels. VII—Heating Value—Gasoline Compared to Kerosene
 828

CHAPTER VI

POWER OF THE GAS ENGINE

- I—Horse-Power Defined—Force—Work—Power. II—Brake and Drawbar Horse-Power. III—Determining Horse-Power—By Formula—By Brake Test. IV—How to Run a Brake Test—Description of Brake—Method of Test—Taking Readings—Figuring the Power Developed. V—When to Use the Brake Test. VI—Test for Fuel Economy..... 833

CHAPTER VII

THE FARM POWER HOUSE

- I—Means of Getting More Work Out of the Engine. II—Convenience of Power House. III—Makes Better Care of Machinery Possible. IV—Location of Power House. V—Arrangement—Separation of Different Classes of Work. VI—Location of Engine—Setting Fuel Tanks. VII—Power House Equipment—Shafting—Pulleys—Belts—Hangers. VIII—Position of Machines with Respect to Line Shaft and Power. IX—Planning of Work. X—Pulley Speeds and Sizes, Rules and Formula for Finding..... 839

CHAPTER VIII

GAS ENGINE TROUBLES

- I—Troubles That Prevent Starting. II—Faulty Ignition. III—Dead Engine. IV—Miscellaneous Troubles—Cylinder Troubles. V—Parts That May Need Adjustment. VI—Worn Valves. VII—Smoke. VIII—Fuel Supply. IX—Bound or Hot Boxes. X—Leaky Gaskets. XI—Deposits in Compression Chamber and Water Jacket. XII—Cracked Water Jacket. XIII—Use of Poor Lubricating Oil. XIV—Care of an Engine. XV—Starting an Engine. XVI—Stopping an Engine. XVII—Magneto Troubles..... 847

CHAPTER IX

CARE OF THE ENGINE

- I—Cleanliness Most Important—Wiping the Engine. II—Overhauling—Removing the Parts—Cleaning Parts—Piston and Cylinder—Cleaning Water Jacket. III—Care of Ignition System—Wiring—Battery Box—Vibrator Adjustment. IV—Removing Carbon Deposits—Kerosene and Denatured Alcohol. V—Housing the Engine 868

CHAPTER X

SELECTING A GAS ENGINE

- I—Essentials in Selecting a Gas Engine—Capacity—Reliability—Cost. II—Purchasers Buy Engines Too Small—Should Have Sufficient Capacity. III—Two Engines Desirable. IV—Power for Various Machines. V—Reliability. VI—Cheap Engines—Most Expensive in the Long Run..... 873

CHAPTER XI

CARE OF THE AUTOMOBILE

- I—Should Begin Before Machine Is Purchased—Study Books of Instruction. II—Driving the Car—Go Slowly Over Rough Roads—Throwing in Clutch. III—Shifting Gears. IV—Steering the Car—Avoid Ruts—Turning Corners. V—Making Repairs. VI—Overhauling..... 877

PART II—THE REPAIR OF FARM EQUIPMENT

- I—Introduction. II—Tools Adapted to Repair Work on the Farm—Wood-Working Tools—Tools and Equipment for Working Iron—Miscellaneous Tools—Harness-

Repair Outfit—Special Conveniences—Combination Tool Outfit—Iron-Working and Shop Equipment. III—Shop Facilities for Repair Work. IV—Materials Required for General Repair Work—Wood Materials for Repairing Farm Equipment—Metal Materials for Repairing Farm Equipment—Supplies for Repair of Harness, Carriage Tops, Etc.—Paints, Oils and Miscellaneous Supplies. V—Suggestions 880

PART III—ROPE AND ITS USE ON THE FARM

I—Introduction. II—General Information—Construction of Rope—Sources of Fiber—Strength of Rope—Table of Information About Three-Strand Rope. III—Preventing the Ends of Rope From Untwisting. IV—Hitches—Sheep Shank—Half Hitch—Timber Hitch—Well Pipe Hitch. V—Halters and Halter Ties—Non-Adjustable Halter—Adjustable Halter. VI—Splices—Short Splices—Long Splices 909

PART IV—PRESERVATION AND TREATMENT OF FENCE POSTS

I—Introduction—Life of Untreated Posts—Substitutes—Costs. II—Cause of Decay—Factors Affecting Durability. III—Prevention of Rot—Old Methods—Other Treatments. IV—The Oil Treatment—Non-Pressure Process—The Plant—The Process—Single Tank—Results. V—Summary 937

PART V—HOUSEHOLD LABOR-SAVING DEVICES

CHAPTER I

THE KITCHEN AND CULINARY HINTS

I—Introduction. II—The Kitchen. III—Culinary Hints—Weights and Measures—Approximate Measures of One Pound—Of One Ounce—General Measures—Proportions for Thickening Agents—For Leavening Agents—For Shortening—To Set a Table—Meat—Bread—Cereals—Cakes and Cookies—Pastry—Jelly Making—Canning Fruits—Canning Vegetables—Miscellaneous Suggestions 952

CHAPTER II

LABOR-SAVING DEVICES

Fireless Cookers—Vacuum Cleaners—Dishwashing Machines—Kitchen Cabinet—Bread Mixer—Cake Mixer—Steam Cooker—Food Chopper—Casserole—Gasoline and Oil Stoves—Double Cookers—Apple Corers and Parers—Strawberry Hullers—Hot Pan Lifter—Cookie Cutter—Coffee Percolators—Slicers—Stoners—Strainer—Holder—Pastry Fork—Fruit Press—Clothes-Horse—Chairs and Benches—Mops and Dusters—Miscellaneous Devices and Methods 971

CHAPTER III

LAUNDRY-SAVING DEVICES

Gasoline Engine—Power Washing Machines—Hand Washers—Boilers—Flatirons—Mangles—Ironing Boards—Home-Made Soap—Special Instructions for Removing Stains—Laundry Helps 985

BOOK XI—THE BUSINESS SIDE OF FARMING

CHAPTER I

FARM RECORDS AND ACCOUNTS

I—Introduction—What Records to Keep. II—Farm Inventories. III—Placing Values on Property—Real Estate—Live Stock—Machinery and Tools—Feeds and Supplies—Bills Others Owe Me—Cash on Hand in Bank—Bills Payable. IV—Cash Accounts. V—Production Records—Milk Record—Egg Record—Breeding Record. VI—The Farm Map. VII—Supplementary Records—Labor Records—Feed-

ing Records—Household Records—Seeding Record. VIII—Summarizing the Year's Record—Financial Report. IX—What Constitutes Farm Profit—How to Determine. X—Some Results of Cost Investigations—Annual Cost of Maintaining a Work Horse—Cost of Producing Farm Crops— Cost of Dairy Cow. XI—Summary 997

CHAPTER II

REPLANNING A FARM FOR PROFIT

I—Introduction. II—How Farms are Replanned by the Office of Farm Management—General Considerations—Fundamental Points—Plan 1—A Grain and Hay Farm—Plan 2—A Grain and Clover-Seed Farm—Plan 3—A Grain and Clover Farm—Plan 4—A Sheep Farm—Plan 5—A Hog Farm—Plan 6—A Dairy Farm. III—Summary of Returns From Different Types of Farming—Plans Given Not Model. IV—Field Management—Natural Field Divisions—Fencing.....1027

CHAPTER III

THE MARKETING OF FARM PRODUCTS

I—Interest in Marketing. II—Marketing a Part of Production. III—Cost of Marketing—Reasons for Variation. IV—Specialization in Marketing. V—Organization of Marketing—Middlemen—At Country Points—Need of Local Shippers—Wholesale Trade—Brokers—Auction Companies—Retail Stores—Chain Stores. VI—Methods of Sale—Basis—Kinds of Sale—by Consignment—Delivered at Destination—Track Sales—Contract Sales. VII—Price Quotations. VIII—Defects in the Present System of Marketing.....1057

CHAPTER IV

THE MARKETING OF GRAINS

I—Marketing at Country Points. II—The Price of Wheat. III—Marketing at Minneapolis—Functions of a Grain Exchange. IV—Future Trading—Contract Grade—Short Selling—Hedging—Pure Speculation—Evils of Speculation.....1073

CHAPTER V

CO-OPERATION

I—Fundamentals of Co-operation—One-Man-One-Vote—Limitation of Shares—Patronage Dividend. II—Conditions Necessary for Successful Co-operation—Specific Object—Management and Accounting—Sufficient Business—Sufficient Capital—Loyalty. III—Co-operation in Minnesota—Summary—Co-operative Creameries—Farmers' Elevators—Co-operative Stores—Live Stock Shipping Association—Insurance Companies—Telephone Companies—Conclusion.1082

CHAPTER VI

CO-OPERATIVE CREAMERIES AND CHEESE FACTORIES

I—Introduction. II—The First Meeting—Questions to be Discussed—Organization Agreement. III—Getting Subscribers. IV—Second Meeting. V—The Building. VI—Hiring the Butter or Cheese Maker. VII—Things Worth Remembering. VIII—Articles of Incorporation—By-Laws.....1094

CHAPTER VII

FARMERS' CLUBS

I—Introduction—What a Club Is. II—Advantages—Social—Educational—Outside Talent—Community Problems—Financial Advantages. III—Co-operation or Peasantry—Economy in Co-operation—Club Promotes Co-operation. IV—How to Organize a Club—Meetings—Suggested Constitution and By-Laws—Form of Program and Order of Business. V—Work to Do—Pace Makers. VI—Co-operative Effort Fostered. VII—Results Accomplished by Farmer's Clubs....1107

CHAPTER VIII

THE SCIENCE OF DAIRYING

I—Why the Babcock Test Is Used. II—Steps in the Babcock Test—Mixing and Sampling—Preserving Samples—Filling the Pipette—Filling the Test Bottle—Adding the Acid—Mixing the Acid and Milk—Whirling the Bottles—Reading the Per Cent of Fat—Cleaning the Bottles. III—Calculating Weight of Fat in Milk. IV—Sampling and Testing the Milk of Different Cows. V—Monthly or Daily

Weighing of the Milk—Sampling Milk at the Barn for the Fat Test. VI—Testing Skim Milk by the Babcock Test. VII—Testing Cream on the Farm. VIII—Reading Cream Tests. IX—Testing the Accuracy of Babcock Test Bottles. X—How Composite Samples Are Made. XI—The Overrun—Factors Influencing Overrun—Overrun From Cream—Overrun Table—Butter—Cheese—Condensed Milk. XII—Calculating Dividends by the Fat Test.....1118

CHAPTER IX

DRESSING AND CURING MEAT

I—Selection of Animals. II—Care Before Killing—Tools Necessary. III—Killing and Dressing Hogs. IV—Cutting Up Hogs—Dressed Hogs for Market. V—Killing and Dressing Cattle. VI—Cutting Up Beef—How to Carry a Quarter. VII—Killing and Dressing Veal—Dressed Veal for Market. VIII—Dressing Sheep—Cutting Mutton. IX—Killing and Dressing Poultry—Dressed Poultry for Market. X—Curing Meat—Recipes. XI—Smoking Meat. XII—Rendering Lard. XIII—Sausage. XV—Fresh Meat—Beef Clubs.....1145

COLORED PLATES

- FRONTISPIECE — A MODEL FARMSTEAD.
- II CORN STALKS FOR SEED SELECTION.
- III A CHAMPION EAR OF CORN.
- IV A MINNESOTA WHEAT FIELD.
- V WORLD CHAMPION APPLE TREE.
- VI BLUE PRINT — MODEL FARM HOUSE — THREE PLANS.
- VII BLUE PRINT — COMBINATION BARN.
- VIII BLUE PRINT — HOG HOUSE.
- IX BLUE PRINT — A-SHAPED HOG HOUSE.
- X BLUE PRINT — TWO-PEN HEN HOUSE.
- XI BLUE PRINT — MACHINERY SHED.
- XII BLUE PRINT — END ELEVATION MACHINERY SHED.
- XIII WILD OATS.
- XIV WILD MUSTARD.
- XV RUSSIAN THISTLE.
- XVI CHESS.
- XVII SOW THISTLE.
- XVIII QUACK GRASS.
- XIX CANADA THISTLE.
- XX OX EYE DAISY.
- XXI WILD BARLEY.
- XXII WHITE GRUBS.
- XXIII CORN WIRE WORM — CLICK BEETLES.
- XXIV ARMY WORM.
- XXV CHINCH BUGS.
- XXVI CORN ROOT LOUSE.
- XXVII CORN ROOT WORMS.
- XXVIII SEED CORN MAGGOT.
- XXIX CORN BILL BUGS.
- XXX THE CORN WORM.
- XXXI COMMON GRAIN WEEVILS AND LARVÆ.
- XXXII ANGOUMOIS GRAIN MOTH.
- XXXIII DISEASES OF THE POTATO.

BOOK I
SEED SELECTION AND STORAGE

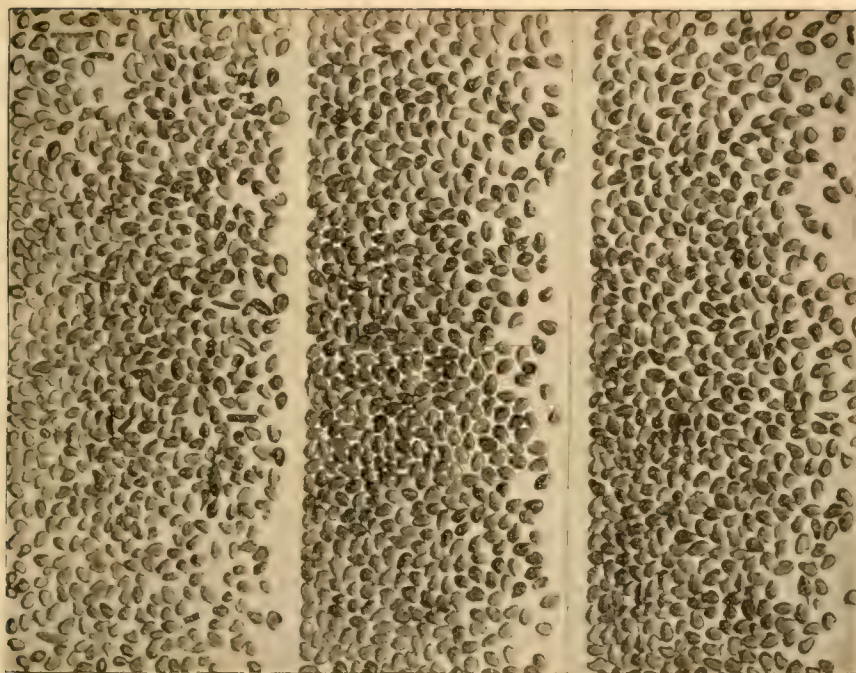

Three Grades of Red Clover Seed; the first shows seed mixed with weed seed and chaff; the second, pure seed; the third, the ordinary grade. Always plant pure seed.

Courtesy of Northrup, King & Co.

SEED SELECTION AND STORAGE

CHAPTER I

Removal of Weed Seed, Chaff and Lightweight Grain

- I. INTRODUCTION. II. WHY LIGHT-WEIGHT SEED SHOULD BE REMOVED. III. WHY WEED SEEDS SHOULD BE REMOVED. IV. WHY CHAFF SHOULD BE REMOVED. V. SOME METHODS OF REMOVAL—THE FANNING MILL—THE ADHERENCE METHOD—SCREENING—HAND SCREENING. VI. CONCLUSION.

Introduction — From actual experience farmers have found that to make progress in breeding animals only the best foundation stock should be used. Farmers no longer look for progress in their herds by using scrub sires, and they have learned to use the Babcock test to weed out all cows that do not bring in sufficient to pay for their keep and leave a margin of profit. The question of farm seeds for the season's crop is of even more importance when we consider that the field crops are the foundation upon which all prosperous agriculture rests. The valuation of our farm crops can be increased one-fourth by careful selection of seeds, all other things equal.

During the winter months before the rush of spring work, the farmer

should clean and grade his seed grain, test all seeds as to their vitality and viability. Where clover or alfalfa seed is to be purchased, it is well to send early to some of the leading seed firms for samples and test, or better send to the state experiment station for a purity and germination test, before placing the order. Many times the success or failure of clover and alfalfa fields are determined by the vitality and purity of the seed. Inferior seed is the frequent means of crop failure. Good alfalfa and clover seed should test 90 per cent germination power or above; no seed except some of the varieties of grass should be sown that does not test at least 80 per cent. Where the viability of seed is low we can rest assured that practically all the seeds are deficient in energy even though a portion germinated.

Why Light-Weight Seed Should Be Removed—Light-weight in seed grain indicates lack of vitality and germinating power. It may be due to lack of water, immaturity, disease, or running out and lack of inherited vitality. However good grain may look, if it is not up to standard in weight we can be sure that it is not up to standard in germination and energy.

Many farmers are apt to confuse size with weight in choosing their seed grains. The size of the grain has little to do with it. Weight is the greatest factor. Of course immaturity and lack of nourishment produce stunted growth, but in this case it is always accompanied by low weight. Then, well matured grain should be large in size, but here again the true test for good grain is its weight, for large grain of poor quality is mostly hull and chaff.

Plump, heavy seed indicates maturity, and, barring carelessness in handling, is sure to germinate well. We cannot afford to take any chances with light-weight undeveloped seed grain. It should always be removed before planting.

Why Weed Seeds Should Be Removed—Weed seeds should be removed because they spread the weeds into other fields. In particular this applies to the so-called noxious weeds, which, when once established in a field, are almost impossible to eradicate. Noxious weeds can be held in check if confined to a corner of one field, and in time eradicated. But for the farmer who scatters noxious weed seed with his grain there is no hope. He will reap the reward of his carelessness.

But, aside from the noxious weed phase of the question, the farmer will have plenty of trouble handling the weeds which come from the ground without adding those which he sows with his impure seed. It is always a good practice to remove weed seed because it lessens the labor required to cultivate. It is also a necessary precaution against the introduction and spreading of noxious weeds.

Many states now have seed inspection laws which fix a penalty for selling or offering for sale seeds that are contaminated with noxious weed seeds.

Why Chaff Should Be Removed—Chaff offers a refuge to insects and moulds, and takes up space that could better be filled with grain. Chaff lessens the weight of grain and makes an error in seed selection by weight. It dries out more slowly than the grain after smut treatments, and gives bacteria and moulds the moisture they require to make a start. At best, it is a nuisance which can easily be avoided by the use of a fanning mill.

Some Methods of Removal—The processes of removing light-weight grain, chaff, and weed seed are based on three differences; difference in size and shape, difference in weight, and difference in the nature of the seed-coat. The simplest process of separation is with the fanning mill, which takes advantage of the first two differences, and is remarkably

SIDE SHAKE FANNING MILL

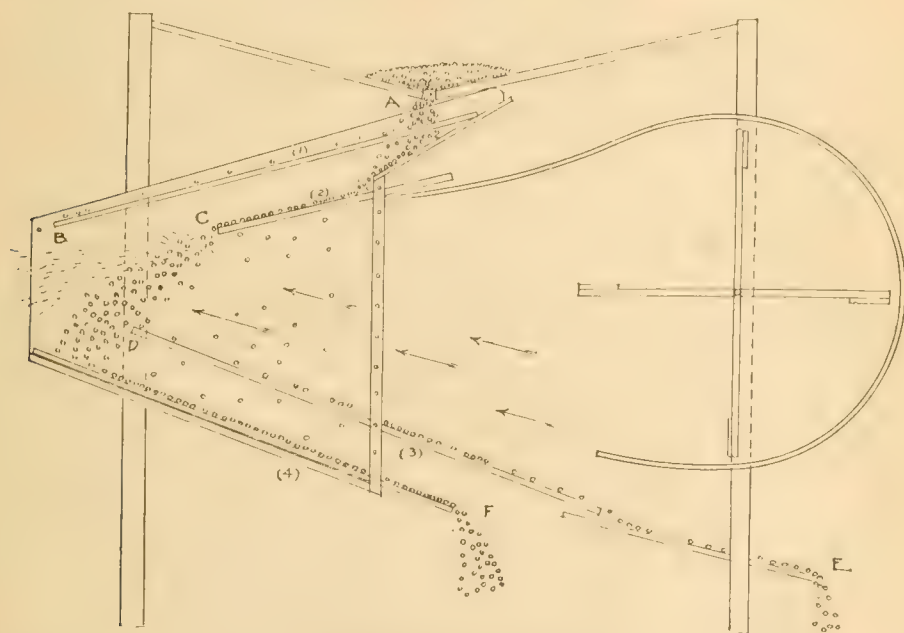

Fig. 1.—Diagram of a Fanning Mill.

effective. The other processes, screening, removing light-weight seeds by gravity, and the adherence method, are to be used in connection with the fanning mill for the removal of seeds and weed seeds which slip through the mill and must subsequently be removed.

As a rule, any process that will remove light-weight grain will also remove weed seeds, because they are both light of weight. It does not follow, however, that any process which removes weed seeds must remove light-weight grain, because light-weight grain cannot be screened out, while most weed seeds can. Because the chaff, light-weight grain, and weed seed are all removed in one process, it is advisable to consider the three processes together in each method.

The Fanning Mill — Figure 1 is a diagram of a fanning mill of the side-shake type. There are other types on the market but the same principle holds true in all. The grain, mixed with seeds of various weeds and chaff, is poured into the hopper at A. The screens vary in size: No. 1 is of a large mesh, No. 2 of a smaller mesh, and No. 3 of a still smaller mesh. When the grain falls through these screens it is met with a blast of air from the fans which blows the chaff, light-weight grain and many of the weed seeds out at B. The grain to be saved for seed is shaken down screen No. 3 which is too small a mesh to let the plump seed through, and deposited at E. The weed seed and broken kernels that escaped the blast of wind pass through screen No. 3 and are collected at F.

Gravity Methods — Barley that is heavy enough for seed purposes will always sink in water. Light-weight barley will not, nor will many weed seeds that infest barley.

A large wooden tub is all the apparatus necessary for removing light-weight barley. A hole is cut near the bottom of the tub, and stopped with a wooden plug. The tub is then set upon two saw-horses and filled two-thirds full of water. The grain is poured into the tub a bushel at a time, and stirred slowly.

The light-weight barley and most of the weed seeds rise to the surface and are skimmed off, while the good seed remains at the bottom of the tub. After the weed and other seeds have all been skimmed off, the plug is removed, the tub drained, and the cleaned grain removed and spread out on a clean floor to dry. Then the hole is plugged, water poured in the tub and the whole process repeated with another bushel.

The seed should be treated for smut at the same time by adding formalin to the water in the tub at the rate of one pound (pint) of formalin to 36 gallons of water.

The Adherence Method — When weed seeds are of the same size and about the same weight as the grain, and so go through the fanning mill with the grain seed, some method must be followed to get them out later.

Some seeds, particularly the buckhorn seeds in clover and alfalfa, are sticky in nature when moist. This gives us another method of removal, known as the adherence method. The contaminated clover or alfalfa seed is allowed to stand in water at 65° F. for five minutes. Then the water is carefully drained off, and the moist seeds are scattered and mixed in dry sawdust until all the clusters are broken up. About five parts of sawdust are required to one part of seed, and the mixing should be done by hand on a clean barn floor.

The sticky buckhorn seeds become coated with sawdust, while the other seeds do not.

Two screens are then arranged, one above the other, as shown in the fanning mill diagram. For clover or alfalfa seed the upper one should be a piece of zinc with many one-fifteenth inch perforations. The lower

one should be No. 22 wire mesh cloth. The size of the perforations in the piece of zinc varies of course with the kind of seed treated. The sawdust containing the clover seed is poured down upon the upper screen. Care must be taken not to put too much on it at a time lest the sawdust be rubbed off the weed seeds. The clover seeds, being free from sawdust, pass readily through the perforations in the plate. But the buckhorn seeds, being glued to a number of sawdust particles, cannot get through and are thus sifted out. This method has a general application for all weed seeds of a sticky nature, which cannot be separated out by the fanning mill. It must be remembered, however, that only undesirable seed which becomes sticky on wetting can be removed by this method.

Screening—Weed seeds are nearly all larger or smaller than grain seed, and can be removed by sifting the grain through a large meshed screen and then through a small meshed one. This is done with the fanning mill, but there are some machines on the market for screening alone. The size of the two meshes depends upon the size of the grain of course, as one must be larger and the other smaller than the grain. Screening is not to be recommended where the fanning mill can be obtained, but it is an efficient way of getting rid of weed seeds and will probably remain in use for some time.

Hand Screening—When great care is to be taken with grain, as in preparing it for exhibits or in fighting noxious weeds, the seed grain should be gone over by hand, and carefully examined with a small hand lens. In this way many weed seeds which have escaped the fanning mill may be removed. It is a slow and laborious process, and should be used only in preparing exhibits.

Conclusion—Use the best fanning mill that can be obtained, and if necessary supplement it with some of the methods just discussed. Every bushel of grain planted must be fanned and fanned heavily. To plant light-weight grain is to get a poor stand and a worse yield. To plant noxious weeds is to deliver your fields into the hand of an aggressive, destructive enemy.

CHAPTER II.

THE SELECTION OF SEED

1. INTRODUCTION. II. DANGER SIGNALS—DISCOLORATION—LIGHT-WEIGHT—DAMAGE.
III. MIXTURES. IV. CONCLUSION.

Introduction— Grain that has been injured by careless handling, that lacks vitality, that is slow in germinating will produce a weak and inferior stand. Against the thousands of mould and disease organisms that infest the fields, these weakened plants stand little show. They are attacked by fungi, by moulds, and by insect pests. They wilt in the slightest drought, and are easily destroyed by disease. If, by chance, they live to reach maturity, their seed will lack vitality, and is too inferior to be used at home or placed on the market for seeding purposes. If, on the other hand, only the best seed is sown and the crops properly grown, harvested and stored, we must just as surely get seed that will produce hardy, thrifty plants, well able to withstand unfavorable conditions and to produce record yields. There is no chance about it. It is a natural law, as invariable and relentless as the law of gravity.

Many farmers seem to believe that wheat which is too poor to be placed on the market may yet be used for seed with safety. They often pay dearly for this notion, for in a few years they may have no grain good enough for the market. To make a success of any cultivated crop one must, year by year, persist in the selection and use of the best possible seed.

The first and greatest question is: Will the seed grow? There is only one way to be sure, and that is to make the germination test. The best looking grain may have been frozen, or killed with chemicals in disinfecting, or binburned. To be sure, most of these mishaps leave certain marks on the seeds by which they can be recognized. Frozen grain is apt to be light-colored and lacking in luster. It looks and is dead. Grains that have been killed with chemicals are very likely to be bleached or stained. Binburned grain is nearly always discolored. But there are always exceptions, and no grain should ever be planted that has not first been through the germination test described in Chapter VII.

The second question is: Will the seed grow well? Will it produce large, thrifty plants? Is it the kind of seed that will produce a bountiful harvest? Guess-work doesn't pay. Every disease, every injury, every inherited weakness leaves an indication on the grain. One has only to observe closely and the indications will stand out like the danger sign at a railroad crossing. The farmer who selects his grain with open eyes, carefully watching for diseased and weak kernels, is the farmer who is going to make grain raising pay. What, then, are some of the danger signals?

Discoloration — The first and greatest indication of poor grain is discoloration. The color of all grain should be bright and rich. White oats should be white; yellow oats, a bright yellow; black oats, a glistening black. Six-row barley should be a light straw color, without a tint of brown. Two-row barley should be nearly dead white. Each seed should have the variety coloring, and any departure from it indicates something wrong. Discoloration due to damage, weathering, or bin-burning always indicates poor quality and low vitality. Bleaching often indicates chemical injury. Blackening indicates injury and the death of the germ. Lack of luster almost invariably is the sign of inherited weakness and low germinating power.

All grain that is badly off color and shows a weak germination should be discarded for seeding purposes, as it is usually injured and lacks vitality. Only bright, lustrous seed is in really good condition.

Light Weight — High weight per bushel always indicates plump, well-filled grain, that should develop into hardy plants. In oats, especially, high weight indicates a good filling of the berry, which might often be overlooked. Low weight, on the other hand, indicates one of two things: either the grain is immature, or it is of very poor quality. Immature grain has a low germinating power. Poor quality may be due to running out, or to the planting of low grade seed. In either case, we do not want it.

Damaged or Diseased Kernels — Where smut is present in large quantities the grain should be treated before planting. (See following chapter for methods of treatment.) It is best to plant unsmutted seed, however, even if it is a little inferior, because of the labor involved in treatment. Where the grain is badly eaten by insects or contains a large number of broken kernels, it should be discarded, for the damaged kernels will not grow. It is safe to say that such grain has been carelessly handled and stored.

Mixtures — No grain should be planted which is mixed with other varieties or other grain. A mixture of varieties causes an uneven stand. A mixture of grain cannot be sold to the best advantage. The seed must be all of one variety, or it is not worth planting.

Conclusion — Care should be taken to get all seed grain for the season's crops properly prepared for sowing and planting before the opening of spring.

Select seed grain of a bright color and a pure luster. Select grain that is not binburned or shrunken, or smutty or diseased. Select grain that is uniform in variety and size. Select grain that is above standard weight. And if you plant and cultivate it as carefully as you have selected it, you cannot fail to have a "bumper crop."

Like begets like, and the careful selection of seed is the first law of grain farming.

CHAPTER III.
THE TREATMENT OF SEEDS FOR SMUT

I. NATURE OF SMUT. II. PREVENTION—CROP ROTATION—CHEMICAL TREATMENT OF SEED BEFORE PLANTING. III. STINKING SMUT OF WHEAT—TREATMENT BY HAND—SMUT MACHINES. IV. OAT SMUT. V. LOOSE SMUT OF WHEAT—TREATMENT. VI. BARLEY SMUT. VII. CORN SMUT.

The Nature of Smut and Its Prevention—Smuts are miniature plants. Unlike most plants, however, they cannot live by their own efforts, but are true parasites. Usually the smut cannot live except upon some particular plant to which it has become adapted and which is known as its host.

Like plants, smuts exist in two widely different forms: as a slender filament, the mycelium, growing deep within the tissues of its host, and as countless minute seeds, the spores, which occur either within or outside of the heads of grain, and are eventually set free and blown about by the wind to infect other grain heads. This complete dual existence of a smut is known as its life history. Only the knowledge of the life history of a smut will give the clue to successful prevention.

Smut cannot be cured, for the mycelium within the stems cannot be reached without fatal injury to the host. We can only prevent it by getting rid of the spores before they have time to germinate and enter the young plants.

There are two ways of getting rid of the spores. As they cannot live except in conjunction with their particular hosts, we can put in some other crop on infected land so that when the spores germinate in the spring they will be literally starved to death. This is one of the greatest reasons for rotation of crops. The greatest infection however, comes, not from the ground, but from the seed. Smut spores are blown from the infected plants and find lodgement within the hull of the berry of the healthy plants. These spores then remain dormant until such grain is planted when they begin to grow at the same time as the little plantlet. If the seed can be treated with some chemical just before planting that will be harmless to the seed and kill the adhering spores, the smut can be very easily controlled. And this is exactly the way in which we do control it.

But in order to treat smut, we must be able to identify it and know its life history, for if we do not know which smut it is we may treat it in a manner which is useless.

Stinking Smut of Wheat—Stinking smut of wheat is identified by blackened and crumbling heads which have a peculiar odor. Upon close

examination it will be found that the wheat grains are but hollow shells, their interiors having been destroyed and replaced with a mass of minute black spores.

The heads and seeds are very much diminished in size.

Stinking smut of wheat forms a dark colored spore which falls to the ground, lives in a dormant stage through the winter, and sends out a tube, the promycelium, in the spring. Now, this promycelium sprouts too early for the grain plant. It cannot enter the plant until the first leaves have appeared at the age of three or four days. So the promycelium



Fig. 1.—The above cut shows the effect of stinking smut of wheat. At the left are three sound heads and a number of sound kernels. At the right there are three smutted heads and a number of smutted kernels. In both the sound and smutted heads a few of the glumes are removed in order that some of the kernels may be seen.

divides up into two or three secondary spores which wait until conditions are favorable and then germinate, sending out a tube which is the true mycelium, or filament, of the smut. When the spores lie close to the wheat plant, they penetrate the stem at a point below the ground line. The true mycelium does not grow very far and if it does not find the plant at the end of four days, the plant is usually safe from infection. As the young, infected plant develops to maturity, the filaments of the smut penetrate deeper and deeper into the various tissues, extending upward until at the blossoming period of the wheat they pass into the young seeds. By the time the wheat is ripe, the smut has eaten away all

the interior of the infected grain, leaving only the hull and forming the characteristic black, peculiarly smelling spore mass within, from which it gets its name.

The spores from the broken grains and broken smut balls produce infection. At harvest time these smut balls are saved in the reaper bundles, and at threshing time they are scattered far and wide into the threshed grain and straw, so that, if proper precautions are not taken, the next crop is certain to be infected. Very little infection comes from the ground. It comes from untreated seed.



Fig. 2. A Machine for Treating Seed for Smut.

Treatment—Obviously this smut cannot be attacked in the ground, for it cannot be reached. It cannot be combated in the mycelial stage, because that would kill the grain. The only place it can be successfully attacked is in the seed, and the best treatment is formaldehyde. Hot water is less than useless. Vapor treatments are ineffective and chemicals generally injure the grain.

Add one pound (pint) of formaldehyde to thirty-six gallons of water. Formaldehyde costs from forty to sixty cents a pound at retail. One gallon of this mixture will treat about two bushels of grain.



Loose Smut of Wheat, Various Stages.

Spread the wheat in a thin layer on a smooth, clean floor or canvas. Sprinkle it with the formaldehyde mixture until it is thoroughly and evenly wet through. A common spray pump is convenient for this work. Shovel the grain over carefully while spraying to be sure that it is all wet. Formaldehyde gas thus diluted is not dangerous and only slightly irritating, although the solution will harden the hands.

Where large quantities of seed grain are to be thus treated some mechanical device for wetting the grain is advisable. After the grain has been thoroughly wet, heap it up again on the floor or canvas, cover it with a tarpaulin or bags, and let it stand for twelve hours. This gives the formaldehyde gas time to penetrate all the infested grains and kill the spores. The grain should then be spread out evenly and allowed to dry. It should be thoroughly dry before being returned to the bins, for the formaldehyde gas soon diffuses and the damp grain in the bins is especially subject to attack by bacteria and moulds.

If the seed grain is treated for prevention of smut just before sowing, the modern force-feed drill will handle it to advantage when quite moist. If the kernels are swollen, the drill should be set to sow a little more than the usual amount.

Oat Smut—Oat smut requires the same kind of treatment, as it has a similar history. It is the spores which get in under the hulls that do the damage here, and formaldehyde is an effective agent against them.

Loose Smut of Wheat—Loose smut is far more destructive than stinking smut of wheat, often causing a loss of half the harvest in badly infested regions.

It may readily be distinguished from stinking smut. The whole head is attacked, turns into a powdery mass (the spores) and blows away, leaving the naked stalk of the rachis.

The smutted head ripens before most of the wheat plants are in bloom, and grows higher than the average heads. The spores are blown about by the wind and fall upon the young flowers.

The spores germinate, sending their filaments through the grain as it develops. These filaments are dormant in the grain through the winter. In the spring the mycelium commences to grow, keeping pace with the wheat plant until it reaches the base of the young wheat seeds. It destroys them and produces vast numbers of spores, which are blown to the other wheat heads and infect them.

Treatment—Formaldehyde is useless in preventing loose smut, because it is not the spore that does the mischief at this time, but the mycelium in the seed, which cannot be reached by the gas. Formaldehyde can kill the spore on the seed, but it cannot injure the mycelium within the seed-coat.

The only effective way to treat loose smut is by the hot water method. First the seed is placed in half-peck bags and soaked for five hours in



Loose Smut of Barley, Various Stages.

water at the ordinary temperature. Then two galvanized iron tubs, each holding perhaps twenty gallons of water, are heated to 129° F. and kept at exactly that temperature. A good standard thermometer should be obtained, and the readings taken very carefully, as the seeds are injured at slightly higher temperatures. It is best to use a couple of gas-line stoves for heating rather than a wood stove, as the temperature can be more easily controlled. It is unsafe to run above 129° F. at any time. The half-peck bags are drained from the cold water and plunged, one at a time, into the first tub of hot water. Each bag is held there for one minute to bring the grain up to the required temperature of 129° F. The bag of grain is then placed in the second tub for ten minutes, stirring the grain to keep it thoroughly exposed to the hot water. Two men, working together, can treat a bushel an hour, or enough in a day to sow a seed plot of from six to ten acres. Spread the grain out on a clean floor or canvas and allow it to dry thoroughly before storing. It may be planted at once by adjusting the planter to allow for the swollen grain. Some allowance should be made for injured germination, and a trifle more grain sown to the acre than is usual.

Barley Smut — Loose smut of barley is a close relative to loose smut of wheat, and follows much the same life history. The hot water method of control is identical with that used for wheat.

Corn Smut — Corn smut does not spread in the same way as the grain smuts. The spores do not infect the grain, but are thought to be blown by the wind from stalk to stalk, and enter the corn plant through soft places in the stalk. The best method of control is to cut out the spore masses when they are young and burn them. Under proper rotation the loss from corn smut is not very great.

CHAPTER IV.

ROTATION AS A MEANS OF BLIGHT CONTROL

- I. INTRODUCTION. II. PRINCIPLE OF ROTATION. III. SOME PROFITABLE ROTATIONS.
IV. PRECAUTIONS IN THE USE OF STRAW-MANURES.

Introduction — Every farmer knows that when a crop is grown on the same field year after year, it becomes inferior in quality and the yield steadily diminishes. For many years this was attributed to soil exhaustion—to the actual using up of the elements of fertility in the soil. We now know that this deterioration is not due to soil depletion alone, but to the attacks of fungi and moulds also.

Potatoes grown continuously on the same soil become infected with potato scab and all the various kinds of rots. These rots and scab organisms live through the winter in the soil and multiply with every crop until at length the field must be given up. So wheat and barley and oats transmit many similar moulds and fungi to the soil, where they live and multiply with each succeeding crop.

Some fungi rot away the roots of the grain plant so that when the hot winds come in heading time, there are no roots left to carry water to the grain heads. These heads cannot then fill out properly, the tip becoming shriveled and shrunken. In the first wind storm, the straw, having no anchoring roots left, crinkles over to the ground. These fungi are the true cause of blights.

Other fungi content themselves with entering the plant and robbing it of the food which it has stored up for itself. The plant, thus deprived of its proper nourishment, cannot grow to its full size, or reach full maturity. The fungi which produce this stunted growth are called canker fungi, and a plant attacked by them is "cankered."

In time the field becomes infested with thousands of these different fungi which lie, literally, in ambush in the old stubble and attack the young grain plants as soon as they emerge from their protecting seed-coats.

The Principle of Rotation — Where the fields are only moderately infected with fungi, moulds, and rusts, the best method of combating them is by crop rotation.

Fortunately for the farmer a given fungus can live only on its host, the plant upon which it is accustomed to feed. Very few fungi can attack more than one kind of a plant, and those which can are confined to close relationship with the host plant. Potato scab fungi cannot affect wheat; wheat fungi cannot affect corn; corn rot fungi cannot affect cotton. It



FIG. 1. CORN ON A PLAT GROWING CORN CONTINUOUSLY.
Courtesy of the United States Department of Agriculture



FIG. 2. SHOVELFUL OF SOIL FROM THE ABOVE PLAT,
Courtesy of the United States Department of Agriculture.



FIG. 3. CORN ON A FIVE-YEAR ROTATION PLAT.

Courtesy of the United States Department of Agriculture.



FIG. 4. SHOVELFUL OF SOIL FROM THE ABOVE PLAT.

Courtesy of the United States Department of Agriculture

is possible for some fungi to attack both wheat and barley, because they are rather closely related and their growth habits are similar. This knowledge gives us a good method for controlling diseases.

We have only to starve the fungi out by planting in succession a number of totally different crops. Very few fungi can live more than a year without their host, and if we keep their particular host plant off the field for two or three years by substituting other crops for it, their destruction is certain. Of course these other crops bring in their particular fungi, but these are starved out in the same manner.

Thus, if we plant corn on a field which has been devoted to clover, the clover fungi cannot live on the corn plants and so die. If we follow corn with a crop of wheat, the corn fungi cannot live on the wheat and so must die. If now we return to clover, the wheat fungi cannot live. The interval of three years between each successive crop insures in most cases the death of all its particular moulds and fungi. The greater the number of different crops in a rotation, the more completely are the fungi destroyed.

Profitable Rotations — Rotations, however, must be composed of profitable crops for the locality. Otherwise the prevention is rendered useless. As a general rule a complete rotation should consist of a year of pasture, a year in legumes of some sort to improve the soil, a year in cultivated crops to get rid of weeds and insects, and a year in grain. On heavy soils, the rotation should include a forage crop to be plowed under in the fall. On sandy soils, clovers, alfalfa, soy beans, vetch, or some similar legume should be given precedence in building up the soil. Cultivated crops can usually be grown for two successive years where profitable, because cultivation holds the fungi in check for a time and cleans the land of weeds. A four or five-year rotation of profitable crops, carefully handled, will improve the quality of all. More than this, if a legume is included, the crop fed on the farm, and the manure carefully handled, the soil will be built up rather than depleted, and the use of commercial fertilizer rendered almost unnecessary.

One of the most common ways of making rotation useless is by being careless about the straw used in manure. We cannot expect to rid our fields of wheat fungi if we spread wheat straw manures over the rest of the rotation. The same is true for all our grains. Do not put manure made from a certain kind of straw upon a field that is to produce that same crop, but put the manure on a field that is to grow some entirely different crop.

CHAPTER V.

TREATMENT TO EXTERMINATE INSECTS FROM GRAIN

- I. WHY GRAIN INSECTS SHOULD BE EXTERMINATED. II. HOW GRAIN BECOMES INFESTED WITH INSECTS. III. PREVENTIVE MEASURES. IV. TREATMENT TO DESTROY INSECTS—MOTH TRAP—FUMIGATION—SULPHUR—HYDROCYANIC ACID GAS—CARBON BISULPHIDE. V. CONCLUSION.

Why Grain Insects Should Be Exterminated — Many insects, working under the common name of grain weevil, attack stored grain. The grain bin furnishes an ample supply of food, it is always dry, it is not open to attack from birds and parasites, and it is rarely disturbed. In short, the grain bin forms an ideal home for insects to live and multiply in.

There are two classes of insects which are particularly destructive in grain: the true grain weevils, which are represented by the granary weevil and the rice weevil, and the grain moths, of which the Angoumois grain moth, or fly weevil, is the most common. The adult beetles eat into the grain kernels for food and shelter, and the larvæ live, feed, and mature within the kernels. The grain moths themselves do not injure grain, but their larvæ pass most of their lives within the grain kernels. Unlike the grain beetles, these larvæ are not content to pass their lives within the narrow walls of a single kernel. They eat their way from kernel to kernel, spinning silken tubes as they go, and feeding from the end of the tubes. When they reach maturity they build their cocoons at the end of these tubes and emerge as full-fledged moths to fly into other bins and infest them.

The damage would not be so great if the moths and beetles did not multiply with such fearful rapidity. It has been estimated that one pair of grain weevils will, in the course of a year, produce over 6,000 descendants; this in a small grain, where food is furnished for only a single larva in each kernel. In corn three or four larvæ may mature in each.

Where the grain is filled with these silken webs or tubes it is worthless.

It cannot be made into flour or fed to live-stock. The tubes cannot be removed. They break up into a webbed mass that is worse than the tubes. The grain will not do for seed, because so many of the kernels have been destroyed. Grain that contains the larvae and adults of grain beetles is obviously unfit for human consumption. It is just about as worthless as that infested with the moths. Usually if the grain is badly affected, both the beetles and moths are present, and the destruction is very great indeed.

How Grain Becomes Infested With Insects—Some insects, like the Angoumois moth, the rice weevil, and the sawtooth beetle are usually found in the ripening grain, particularly in corn, where they have entered from the field. As a general rule, the grain is partially matured, or at least nearly grown before it is attacked by the insects, and it is probable that they come from some place where grain has been stored through the winter. As we cannot hope to kill all the insects in stored grain and thus prevent their wandering out into the fields, the logical thing to do is to prevent their getting back into the bins again. But by far the greater amount of infection comes from the insects which remain in the bins from year to year.

Farmers will often say that their bins and cribs are never empty. They place new corn on top of a few bushels of old corn literally overrun with beetles, and place new wheat in the bin on top of old wheat which is being devoured by insects. No wonder their grain is destroyed by pests.

Preventive Measures—Small cereals like wheat and rye should be threshed as soon as dry enough, as threshing destroys many of the insects and dislodges their eggs. The adult Angoumois grain moth is easily crushed, and is usually destroyed in handling and threshing.

After it is threshed the grain should be stored in tight bins or in sacks, the latter being preferable, because the moths that mature will die without escaping. Grain should not be cut and stacked in the field for several months. Such practice allows the insects to infest the grain more readily than if it were stored in large quantities, for here they can go all through the grain, while in storage only the surface layers are exposed.

Corn should not be husked where there is much danger of infestation, but should be stored in the husk. A husk which fits tightly over the end of the corn is an armor plate against attack by the ordinary granary insects. The corn should, however, be housed early, because the corn ear-worm, in making its entrance, and exit, leaves holes through which the grain weevils can pass into the ears.

The most important preventive measure is to keep the bins clean. If the old grain has not been used up before harvest time it should be taken out before the fresh grain is put in. If the old grain is badly infested, it should be burned, for the insects will leave it for the standing grain if it is simply thrown out on the ground. After the old grain has been removed, the bins should be thoroughly scrubbed with a solution of carbon bisulphide, to kill any eggs or insects which may remain. It is not sufficient to go over them hastily with a spray pump. The disinfectant must be driven into every crack and knot hole which can contain an insect. Carbon bisulphide is explosive. Keep fire away.

TREATMENT TO DESTROY INSECTS

The Moth Trap—Where one has only the grain moths to deal with, their destruction is a simple matter. All of the grain moths are nocturnal

in their habits, and may be attracted by lights. Fill several large shallow pans with kerosene and place them in different parts of the granary. Suspend a lighted lantern over each pan. The moths will fly towards the light, strike against the glass of the lantern, and fall into the kerosene in the pan beneath. If the moths do not drown in the pans, the kerosene will eventually kill them.

These traps may be used in the spring when the Angoumois moths emerge, or at any time when the moths become abundant. Great care should be taken in setting the lantern, for should it fall or be displaced, the kerosene would probably catch fire and endanger the building. By placing the kerosene pan within another larger pan, this danger is diminished, since the fire cannot spread to the wood.

Fumigation—Fumigation is the best method of treating seeds for insects, because the gas fills the space between the kernels more thoroughly and gets into the damaged grain better than a liquid. Then, liquid disinfectants might injure the seed or start germination which a gas cannot do.

Sulphur—When sulphur is burned, a poisonous gas known as sulphur dioxide is given off. This gas will kill all grain insects, not only in the adult forms, but in the larvæ and pupæ stages as well.

First compute the number of cubic feet in the bin (by multiplying its length, breadth and depth together). Sulphur should never be burned in stronger concentration than two and a half pounds to 1,000 cubic feet of space. Even at this concentration it weakens the germinating power of the grain. Seal all cracks with strips of tough wrapping paper. Then place the requisite amount of sulphur in a metal dish—a pie tin will do—and set this in the bin. Wet one side of the piece of sulphur with alcohol. Do not hold the alcohol bottle in the other hand while you are striking the match. Set it down away from the bin where it cannot make trouble.

After the sulphur is burning well, shut the bin door or cover, and seal it, too, with strips of paper. Leave the bin untouched for twenty-four hours, and then open it and allow it to air out.

There are two very serious objections to sulphur as a fumigator. The first is that it is too powerful. It not only kills the insects, but it weakens and destroys the germinating power of the seed, so that it soon spoils, and is rendered unfit for planting purposes. The second is that sulphur dioxide bleaches the grain in a moist bin, injuring the color and lowering its quality.

While sulphur dioxide is not well adapted for grain fumigation, yet it can be used successfully in cleaning up the bins to prepare them for new grain after the old grain has been removed.

Hydrocyanic Acid Gas—Hydrocyanic acid gas kills all insects very effectively. It is a deadly poison, however, far too dangerous to be used on the farm. One breath of the gas is sufficient to kill a man. It should be used only by experts, and then only for diseases and pests which cannot be controlled any other way.

Carbon Bisulphide— Carbon bisulphide is a heavy, clear, foul-smelling liquid, which evaporates rapidly when exposed in shallow dishes. The vapor is a deadly poison when confined in a sufficient quantity, killing all granary insects in every stage of growth. It is heavier than air, and settles rapidly through the grain to the bottom of the bin. Unlike sulphur dioxide, it does not weaken the germinating power of the grain.

Carbon bisulphide diffuses very rapidly, however. It is not sufficient to cover the top of the bin with bags under the supposition that because the carbon bisulphide is heavier than air it will remain in the bin. The gas filters out through the cracks and crevices with amazing rapidity, and if the top of the bin is not sealed down, the insects will not be killed at all, because the gas has diffused into the outer air so fast that it has never reached them. Indeed, the way most farmers treat their grain only makes the insects sick for a little while, and does not kill them at all. To be effective, the bins must be airtight, or as nearly airtight as it is possible to make them. This prevents abnormal diffusion, and keeps the carbon bisulphide in the bin until it has had time to penetrate into the grain and kill the insects. It also keeps the gas from becoming too weak to be effective.

All sorts of promises have been made for carbon bisulphide. One writer has even gone so far as to claim that "one pound of carbon bisulphide poured over one hundred bushels of corn will kill all the insects, even in open cribs." Nothing could be more ridiculous. In the open crib the carbon bisulphide would all diffuse into the open air. There would not be any left to kill the insects.

Seal the bins up as tightly as possible with paper. Compute the cubic volume of the bin and measure out the carbon bisulphide accordingly. From five to ten pounds of carbon bisulphide will be needed to each thousand cubic feet of space, depending upon how tightly the bins can be sealed. Place the proper amount of the bisulphide in a tin pan, set this down in the grain bin, and shut the door, sealing it with paper the same as for the sulphur dioxide fumigation. The bins should be left sealed for twenty-four hours at least.

Small quantities of infested grain can be fumigated best in absolutely tight boxes or barrels by using one ounce of carbon bisulphide to three bushels of grain.

Caution— The vapor of carbon bisulphide is not only inflammable, but explosive. There must be no lighted lantern or fire of any kind brought around while the fumigation is being made. Any supply on hand should be kept securely sealed and placed in a ventilated room. As a further precaution, it should be plainly labeled "Inflammable."

The retail price of carbon bisulphide is about thirty to thirty-five cents a pound from retail druggists, but can be obtained for as low as eight or ten cents per pound from the manufacturers, who make a special fumigating grade.

Conclusion — The greatest step in the extermination of insects from grain is preventing them from getting into the new grain each year. Clean the old grain and the old corn out of your bins. If it is badly infested burn it up. There will not be much left anyhow. Fumigate the cleaned out bins with sulphur dioxide in the manner discussed. It is cheaper than carbon bisulphide, and at this time there is nothing that it can injure.

Don't leave your grain in shocks, or stacked up in the fields, where the insects can get into it when they leave the bins. Stack it in the barn or near it, so that the insects cannot get into it very deep.

Fumigate the grain in the bins if the insects get into it. Don't wait until the grain is ruined. Get after them at once with the carbon bisulphide, before they have had time to do very much damage.

There are two great rules in exterminating grain insects, and the farmer should learn them by heart. (1) Clean up the bins before you put any fresh grain in. (2) Seal everything air-tight when you fumigate. If you follow them, the grain insects can be exterminated and kept exterminated as long as you wish.

CHAPTER VI.

STORING GRAIN

I. THE PRINCIPLES OF GRAIN STORAGE. II. CONSTRUCTION OF THE BINS. III. LOCATION OF THE BINS. IV. TIME TO STORE GRAIN. V. SOME PRECAUTIONS IN STORING GRAIN.

The Principles of Grain Storage — Grain is stored for two reasons, convenience in handling, and protection from weathering, insects and rodents.

The bins must be in a convenient place. If the farm is a grain farm, the granary must be centrally located, so as to avoid excessive haulage. If it is a dairy or stock farm, the bins must be near the mixing rooms and feed boxes, so that labor and time may not be wasted in feeding.

The bins must be tight enough to keep out all insects and other pests that feed upon the grain and render it worthless for man or stock. Especially is this true in regard to rats and mice, which destroy great quantities of grain when they have free access to it.

The bins must be water-tight. Not only must the roof above them be tight, but the walls also, since the slightest moisture in the grain causes the growth of thousands of destructive moulds and fungi. These ruin the grain when present in any considerable number.

The bins must have air circulation through them, not a great deal, to be sure, but still a pronounced circulation. Because the seed does not move or show any evidence of life, we are too apt to regard it as inanimate, much as we regard stones and sand. Seeds are not dead, and should not be treated as if they were. Seeds are living and breathing plants, just as much so as the lily bulbs in our gardens or the trees which grow in our front yards. They must have oxygen during their period of storage, and to get this, they must have air. If they cannot get the small amount of fresh air which they require, they die, and the grain is spoiled for seeding or feeding purposes.

Seeds are peculiar in their methods of securing the necessary oxygen. When the supply is cut off from without, the seed does not die as an animal would, at once. It sets out to secure the necessary oxygen by re-arranging its own tissues, and in so doing, the whole character of the grain is changed, fermented, we call it, so that it loses its value as a foodstuff. But if the oxygen is cut off too long, even this re-arrangement cannot save the seed, and it suffocates and dies.

As soon as the fermentative changes begin, the seed loses its power to resist bacterial action, and it may become infected with various rots and

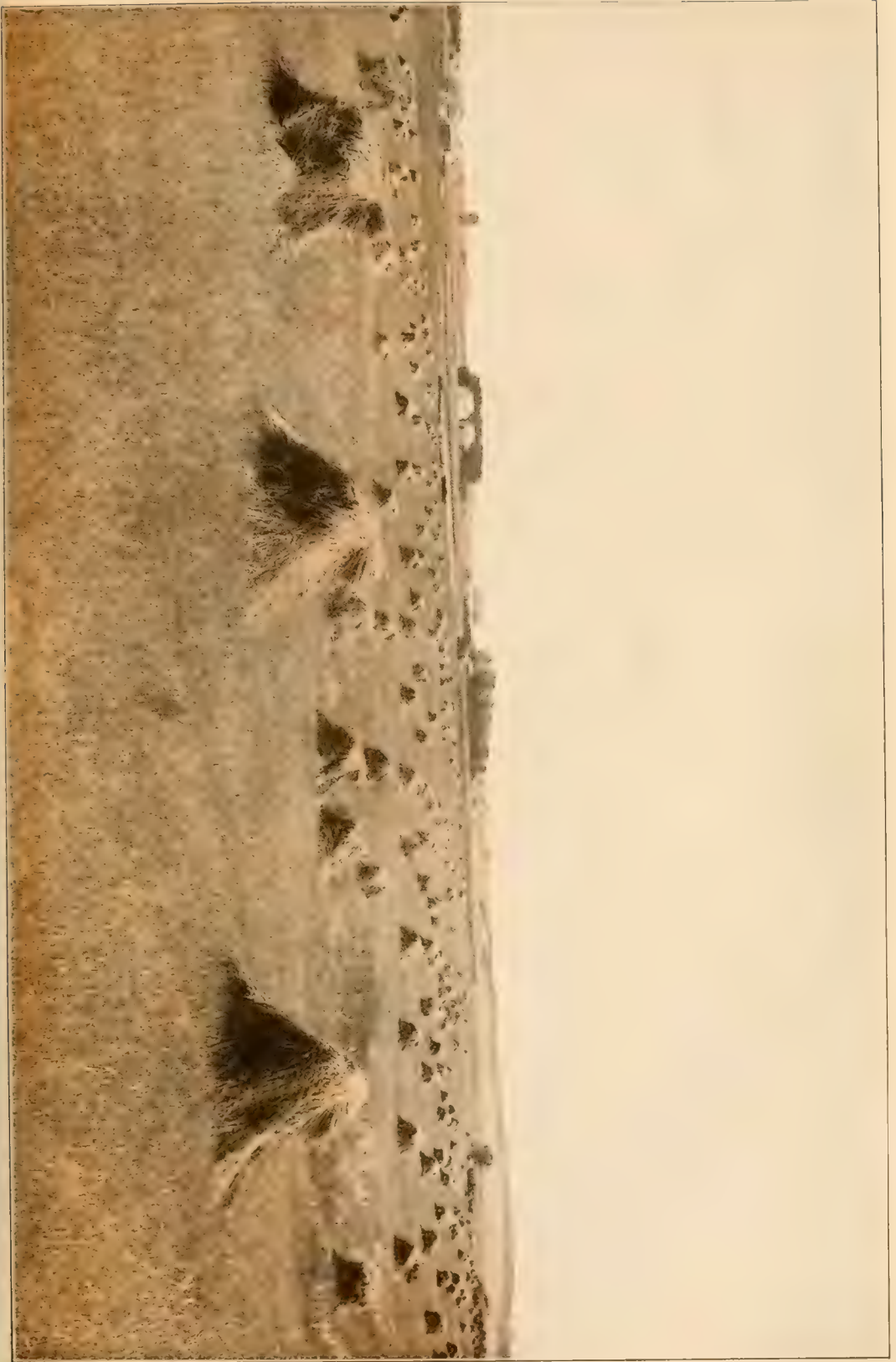

infections. Later, when the fermentation has progressed to some extent, the mass becomes too acid for bacterial life. Then the moulds, which thrive in an acid element, step in and in a short time the grain is ruined.

It is essential, then, that the grain bins be so constructed that air can circulate slowly through them, to give the seeds a sufficient amount of oxygen.

The Construction of the Bins — Bearing all these general principles in mind, let us see which construction is best for the grain bin or granary. Obviously a bin built entirely of cement would be both vermin-proof and water-proof. It would be inexpensive and could be easily cleaned. But how about the circulation of air? Alas, there cannot be any circulation of air, for cement is not only water-proof but air-proof as well. Grain which is stored in cement bins for any length of time will ferment and mould. This is the trouble that grain dealers are having with the big cement grain elevators in Chicago and elsewhere. They cannot store grain in them longer than six months without having it ferment and spoil on their hands. They must either get rid of it, shift it from place to place, or sell it before it ferments. A solid cement grain bin should never be used.

A wooden grain bin will permit air circulation readily enough, but rodents can gnaw into it without any trouble. Mice usually gnaw into the bin through the floor and at the corners. Where it is possible, the grain bins should be constructed with a cement floor, and with a cement ledge six inches high around it upon which the wooden walls of the bin rest. This prevents rodents from gnawing into the bins, and at the same time allows air circulation.

When bins are placed in the second story, as they should be on a stock farm, cement floors cannot be used very well. In this case rodents may be kept out by carefully fitting and tacking strips of tin along the junctions of the floors and walls, paying especial attention to corners.

Location of the Bins — Grain bins, whether in the granary or in the barn, can be most conveniently arranged on the second floor, above the mixing rooms. This permits the farmer to spout his grain down into the mixing room, and avail himself of the cheapest of all power—gravity. It is cheaper in the end to elevate, haul or carry the grain upstairs once, than to shovel grain three hundred and sixty-five mornings and evenings.

A full discussion of the granary will be found under Book VII, Chapter XI, entitled, "The Granary."

Some Precautions in Storing Grain — Grain should be stored as soon as it is threshed if it is dry and has sweated in the stack. When grain is threshed direct from the shocks, in the field, or when it has not been stacked long enough to have thoroughly sweated, it should never be stored immediately. Under these conditions, the grain would sweat in the bin, and a high temperature with a discoloration and loss of vitality would ensue. When the grain is threshed direct from the field it should

be spread out on the floor and allowed to sweat and become thoroughly dry before storing it in bins.

Grain should always be thoroughly dry before it is stored. When it is stored damp, or wet, it does not dry out for some time. Damp grain, moreover, always has the spores of various moulds and rots adhering to it. When the grain is stored, these spores germinate and spread rapidly through the grain, eating their way into the hearts of many seeds, and utterly ruining them. Because the grain cannot dry out quickly, these rot and mould filaments have ample time to spread throughout the entire bin and infect practically all the grain. For this reason, grain must not be stored when wet, or even slightly damp. Moreover, spores do not cling so tenaciously to grain which is dry. When the bins are properly protected from rain, the spores cannot germinate, because, like seeds, they cannot grow without the requisite amount of moisture.

Another reason for storing grain dry is this. The grain bin is nearly always warm enough to permit germination. The reason that the seeds do not germinate is because there is not sufficient moisture. If the seed is stored wet, germination will follow, and even if the seeds only start to germinate, they will not grow when planted, and are especially subject to fermentation.

CHAPTER VII.

TESTING SEEDS FOR GERMINATION

- I. WHY TEST FOR GERMINATION. II. THE PRINCIPLES UNDERLYING THE GERMINATION TESTS. III. HOME GERMINATION TESTS—SEED-TABLE FOR GERMINATING TESTS—BLOTTING PAPER TEST—NUMBER OF SEEDS TO TEST—COTTON FLANNEL TEST—TABLE FOR TIME OF TESTS—INTERPRETING THE TEST. IV. THE BOX-TESTER. V. VALUE OF COMPARATIVE TESTS. VI. CONCLUSION.

Why Test for Germination?—Every dead kernel of wheat planted means a missing wheat plant. Every dead pod or seed ball of beets planted means three or four missing beets. Every dead ear of corn means about nine hundred missing hills. The farmer who thinks germination tests are newfangled and useless should use his arithmetic a little.

One cannot tell simply by looking at seeds whether they will grow or not. They may be very good seeds as far as looks are concerned and very poor when it comes to germination. It is merely a guess—how good a guess will depend upon the expertness of the farmer. It is not safe to plant any seed without first knowing its germinative power.

The Principles Underlying the Germination Tests—Two things are essential to germination, the right amount of heat, and the right amount of moisture. Whenever these conditions occur, the seed will germinate.

When weed seed drops to the ground in the fall and is covered by snow, it doubtless has enough moisture for germination. But it has not the right temperature, and so remains dormant throughout the winter. When seed grain is stored in the granary, it often has the requisite temperature for germination, but there is no moisture, and it cannot germinate without moisture. Thus we see that the heat and moisture must act at the same time to start the plant.

The time of germination is immaterial. Most seeds will germinate at any time when the requisite conditions of temperature and moisture are fulfilled. This is often the case when grain is stored away moist, or becomes wet in the granary, and sprouts. This is true germination, and if sprouted grain is planted, it will not grow with its usual vigor.

Grain happens to sprout in the spring because temperature and moisture are just right, not through any choice of its own.

The success of our germination tests depends on how well we can fool the plant into thinking spring is at hand. The seed must be kept warm while germinating, and must be given all the water it needs. It will then germinate automatically. Since we are going to grow our seed in the

field, it is always well to approach field conditions as nearly as possible in making the tests. We can then tell more closely how the seed is going to act.

But the main thing in germination tests is to find out how many dead seeds there are in a given sample, and the more careful work in imitating field conditions can be left to the botanist and plant pathologist. That is their business.

Home Germination Tests—In order to germinate, a seed needs proper conditions of heat, air and moisture. The different seeds require different conditions for the best results of germination. For instance, large seeds germinate best between folds of cotton flannel, kept wet, but not dripping. However, in testing corn the sawdust germination box is generally used. Smaller seeds grow best between folds of moist blotting paper, and very small seeds germinate most successfully on top of moist folds of blotting paper. The reasons for these differences are found in the fact that large seeds would not get sufficient moisture between or on top of blotting paper, while the smaller seeds would get entirely too much moisture if placed between moist folds of cotton flannel. From these facts the following table has been work out:

Seeds to be germinated between folds of moist cotton flannel.....	}	Corn
		Peas
		Beans
		Pumpkin
		Squash
		Watermelon
		Brome grass
		Buckwheat
		Hemp
		Millet
		Muskmelon
		Onion
		Seeds to be germinated between folds of moist blotting paper.....
Beets		
Alfalfa		
Red clover		
Mammoth clover		
Wheat		
Rye		
Barley		
Rape		
Timothy		
Flax		
Seeds to be germinated on top of blotting paper. . .	}	Alsike clover
		White clover
		Red top

In each case, whether blotters or cloths are used, they should be wet, but not dripping.

It has been found that some seeds germinate best when a variable temperature is used; but for ordinary home test good results can be obtained when a temperature of 68 to 70° F. is used. This is the ordinary living-room temperature.

The Blotting Paper Test—Procure a number of plates and some blotting paper. Place one square of blotting paper on the bottom of the

plate and pour water on it until the blotter has absorbed all the water it will hold. Take just 100 seeds from the sample to be tested, and scatter them rather evenly upon the wet blotter. Then cover them carefully with a second piece of blotter. The first blotter should still be wet enough to thoroughly dampen the upper one. If it is not, a little more water should be added, as the right amount of moisture is the important part of the test.

Drain off all the surplus water, or the seeds will not be able to get air and will drown. Then cover with a second plate a little smaller, and set away on a window sill or near the stove, where there will be sufficient warmth. The seeds should be kept at a temperature of 70° F. The upper plate will check evaporation, but the blotters will probably require a little water every day. This is important, because if the water evaporates even for a short time the seeds dry up, and the whole test is ruined.



Fig. 1.—Germination test of wheat, at end of third day; between folds of moist blotting-paper.

Courtesy of the Minnesota Experiment Station.

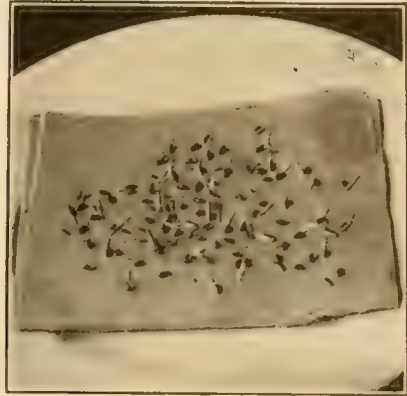

Fig. 2.—Germination test of flax, at end of third day; on top of moist blotting-paper.

Courtesy of the Minnesota Experiment Station.

In from four to six days germination should be complete. Remove the top piece of blotter carefully. Divide the seeds into three classes: those that do not germinate at all, those that germinate feebly, and those that germinate well. Count the number in each class and record carefully, together with the number of the bin from which the seeds were taken.

If there are more than fifteen dead seeds, or more than twenty-five poorly germinated ones, the seed should not be used. The risk of losing the crop is too great. The smallest seeds like timothy or clover should be placed for germination on top of the blotting paper, and tested under the same conditions as the larger seeds.

The Number of Seeds to Test—Germination is always reckoned in per cent. Thus a germination power of 85 per cent, means that eighty-five seeds out of one hundred germinated, and a germination

power of 80 per cent means that only eighty seeds in a hundred germinated. If ten seeds germinate out of one hundred tested, we may be fairly certain that if we tested a thousand seeds only one hundred would be alive. This may not be strictly true, but it is near enough so for all practical purposes.

In testing seed, then, we should always test ten seeds, or a multiple of ten, because that gives the per cent of germination direct, without any

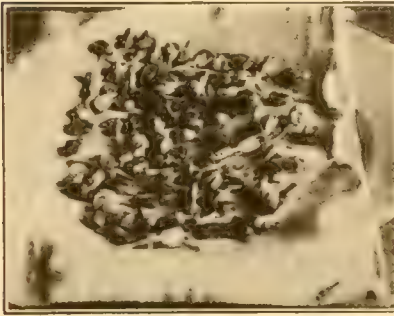

Fig. 3.—Germination test at end of third day; between folds of moist cotton flannel.

Courtesy of the Minnesota Experiment Station.

extra figuring beyond moving the decimal point. Of course, the more seeds that we use, the more accurate are our results. One hundred seeds will be more accurate than ten, and one thousand seeds will give a more accurate test than one hundred. The best method, however, is to test either ten or one hundred seeds according to the size and importance of the seed.

The Cotton Flannel Test—

Where large seeds, such as bean seeds, and cotton seeds are used, the cotton flannel should be substituted

for the blotter. The following table will be helpful in knowing how many days after placing the seed the tests should run, and when the counts should be made:

Kind of Seed	Seed-bed	First count of sprouts	Final count of sprouts
Beans.....	between cloth	3 days	6 days
Corn.....	between cloth	3 days	5 days
Pumpkin.....	between cloth	3 days	6 days
Squash.....	between cloth	3 days	6 days
Watermelon.....	between cloth	3 days	6 days
Beets.....	between blotting paper	4 days	10 days
Cucumber.....	between blotting paper	4 days	10 days
Hemp.....	between blotting paper	3 days	6 days
Oats.....	between blotting paper	3 days	6 days
Wheat.....	between blotting paper	3 days	5 days
Barley.....	between blotting paper	3 days	5 days
Rye.....	between blotting paper	3 days	6 days
Rape.....	between blotting paper	3 days	5 days
Alfalfa.....	between blotting paper	3 days	6 days
Red clover.....	between blotting paper	3 days	5 days
Mammoth clover.....	between blotting paper	3 days	5 days
Timothy.....	on top of blotting paper	3 days	6 days
Red top.....	on top of blotting paper	5 days	10 days
White clover.....	on top of blotting paper	3 days	5 days
Alsike clover.....	on top of blotting paper	3 days	5 days
Flax.....	on top of blotting paper	3 days	5 days

Interpreting the Test—When the seeds have germinated, divide into three classes, the dead, poorly developed, and good plants. A higher germinating power is demanded of larger seed than of small seed like clover or wheat, because we sow so much less seed to the acre, and the loss of a single plant leaves a larger gap.

No seed should be planted where the test shows more than one dead

seed and more than two poorly developed ones out of ten. A germinating power of ninety is demanded of almost all of the larger seeds.

The box tester is used with corn almost exclusively. Make a wooden box, sixteen by twenty inches and about four inches deep. Fill this box about half full of moist sawdust, and cut a square of muslin to fit the box. Mark this off with an ordinary lead pencil (ink will blur) into two-inch squares, and number each in regular order. Fit this muslin, numbered side up, over the sawdust, and tack it to the sides of the box. Cut another piece of muslin to fit as a cover, and make a bag to be filled with sawdust and fitted over the seeds when they are in position. Now we are ready to set up the test.

Number each ear of corn to be tested, remove six kernels from opposite sides of the ear, being careful not to select butt or tip kernels, and place them in the square which bears the number of the ear. When the box is full, cover with the second piece of muslin, fill the bag with sawdust, and fit it over the box carefully.

At the end of four or five days, the box can be opened and the germination noted. As each square represents a certain ear of corn, those ears which correspond to dead or poorly germinated squares can be at once discarded. Before the final shelling of seed corn, the "butt" and "tip" kernels should be removed. No farmer can plant uniformly when the kernels are irregular in size.

Full and detailed particulars of corn testing are given in Chapter I, Book II, under "The Selection of Seed Corn."

The Value of Comparative Tests — Where two or three bins of grain or other seed may be used for seed purposes, it is always wise to test all the bins at the same time, using a number of plates or pans to do it. In this way, one can get a clear idea as to which bin of seed germinates the best, and should be used for seed. One should never forget which bin the seed came from, as this renders the whole test useless. A good plan is to number each bin with a piece of chalk, and copy the number of the bin on the pan with chalk as soon as the test is set up. Care should be taken in reading the test to record not only the per cent of germination and per cent of weak germination, but also the number of the sack or bin from which the seed was taken.

Conclusion — The germination test is one of the essential points to be observed in farming. The time is past when the farmer can guess that his seed is good, and trust to Providence to pull him through the year. He must know what he is planting, know that it will grow and grow well. Chances are dangerous things when backed by the present economic pressure, and only millionaires can afford to indulge in them. The farmer must make sure of his ground by testing his seed for germination. If his seed grain gives a low germination test it will pay him to purchase new seed and use his for feeding purposes, rather than run the risk of planting it.

BOOK II
SPECIAL POINTERS ON CROPS



SHANK TOO LONG

JUST RIGHT
POSITION OF EAR

SHANK TOO SHORT



Fig. 1.—World's Champion Corn. First Prize Exhibit at the National Corn Exposition. Courtesy of the Wisconsin Experiment Station.

SPECIAL POINTERS ON CROPS

CHAPTER I.

CORN

Part I—The Selection of Seed Corn

- I. THE JUDGING OF CORN—SIGNS OF POOR GERMINATION—SIGNS OF IMMATURITY—MARKS OF WEAKNESS. II. CURING AND STORING—WAYS OF STRINGING—THE CORN TREE. III. TESTING SEED CORN—SAWDUST BOX TEST—"RAG DOLL."

Part II—Cultivation of Corn

- I. PLOWING—DEPTH TO PLOW. II. PLANTING—DEPTH TO PLANT—CHECKING. III. CULTIVATION. IV. HARVESTING. V. ROTATIONS.

THE SELECTION OF SEED CORN

To plant a weak or a dead ear means from 600 to 900 poor or missing stalks. Poor stalks and missing hills mean wasted land and wasted labor. There is only one sure way to secure a good stand of corn, and that is to plant live, thrifty, high-yielding seed.

The best way to improve corn is to select the ears directly from the special seed plat, from definite stalks. While the corn is still in the milk stage, the farmer should go through the seed field and mark the most promising plants by tying a colored string around their stalks. These plants should be medium sized and leafy, and the ear should be borne about three feet from the ground. Only those plants which bear a single ear should be selected, and that ear should be of the best size and quality. Plants that are selected to grow one ear to the stalk will give a much higher percentage of high-priced seed corn than plants that have two or more ears. In choosing, the farmer should be careful to distinguish

between plants whose growth is due to favorable conditions of soil and moisture and those plants which are naturally thrifty. It is better to select the best plants from a poor part of the field than to select isolated plants which may have been located over a former compost heap or have been otherwise favored. The former are really thrifty, and will transmit their thriftiness to their offspring. The latter have been lucky — nothing more.

Before cutting time, when the husks have turned yellow, the farmer should go into the field and pick the best ears from the marked stalks.

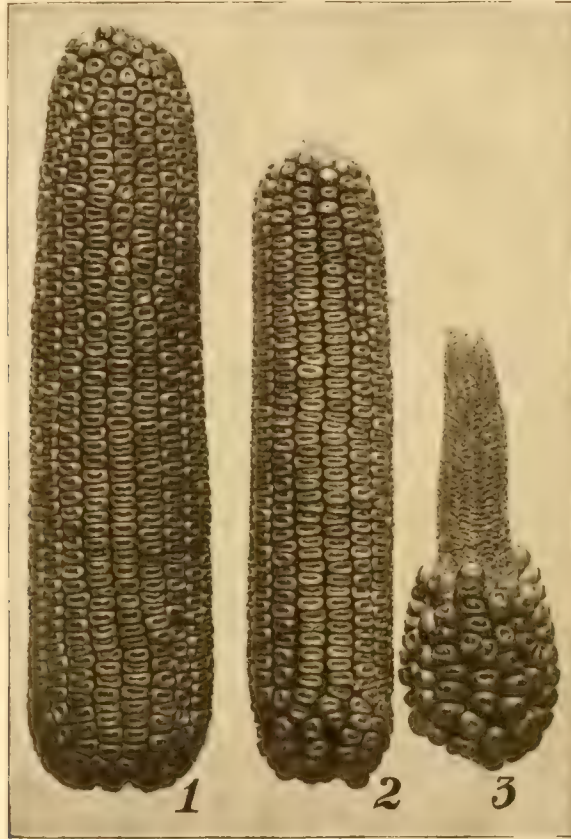
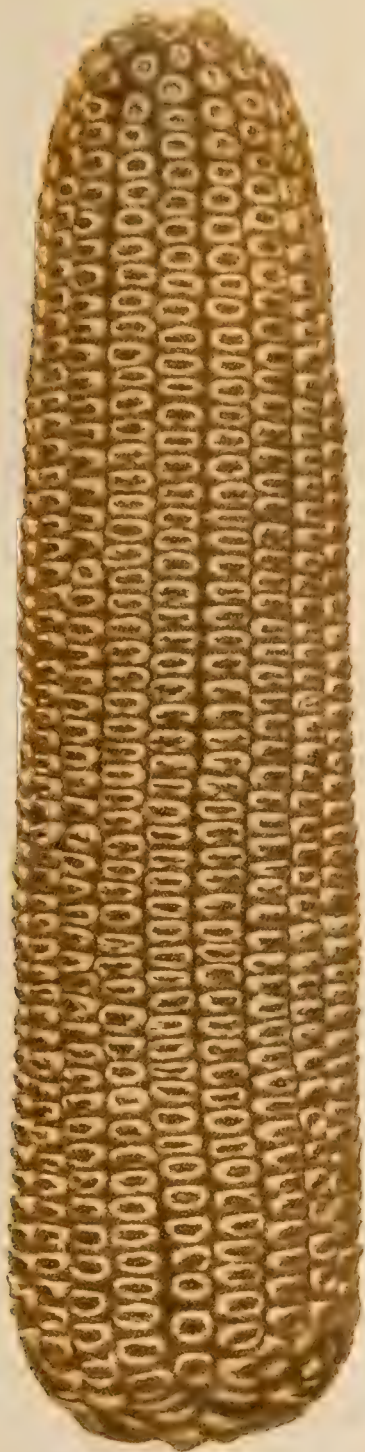

Fig. 2.—Product of a single hill. If we could locate all the stalks in the field which spring from the brothers of the kernel that produced No. 1 we should find that the great majority of them were ears, on an average, as good as it is. The same thing would hold true in the case of the parents of Nos. 2 and 3. This would lead us to the conclusion that the difference in these three ears is due to the difference in the producing power of their parents.

It is a common practice to pick the earliest maturing ears, taking them as soon as the husks begin to turn yellow. Earliness thus secured is at the expense of vitality. The corn should be left in the field until the husks are yellow and the kernels of corn are dented and glazed to insure its maximum vitality.



IDEAL EAR OF CORN

After the seed corn is husked, many ears will be found imperfect, and must be discarded. Only those ears should be retained for seed that are of good form. The corn after picking should not be dumped on the threshing floor nor in some room to remain in the husk for several days. It should be husked the same day it is brought from the field and put in a curing room where there is a free circulation of air.

The general method of field selection, and the one most commonly followed, is to take the best ears from the corn at husking time. While it is perfectly possible to select the best formed ears at this time, nothing can be known about the plants from which they came. It is therefore advisable for the farmer to have a few acres where he can select in accordance with the method advocated at the beginning of the chapter, so as to gradually improve his corn. A method of seed selection commonly practiced by farmers is to go into the field in advance of the binder and select most promising ears and save them for seed. This does not admit of the careful study of the plant but is a good method of large field selection.

A method which is yet quite general is to select the ears from the corn-crib. This cannot be too much condemned. Not only are all the faults of selecting from the harvest multiplied, but added to these is the danger of planting frozen and damaged corn. Indeed, corn that has been in the crib through a severe freeze is never worth planting. Many ears are completely dead and the remainder have lost much of their vitality.

Never select corn from the crib. The intelligent way to select corn is to go out into the field and pick it from the most promising plants. A little carefulness on the part of the farmer will give large yields.

The Judging of Corn—The first question which the farmer should ask himself is: Will this ear of corn grow? Has it life?

There is only one way to know, and that is to germinate a few kernels by the method described under "Testing Seed Corn." We can trust our eyes to some extent, but the final test is the germination box. Remove several kernels from various parts of the ear. Poor germination is indicated by a dark colored, salvy or cheesy germ, or by a wrinkled or shrunken germ. Kernels with starchy, blistered backs, and shrunken, pointed tips, will not germinate well. Kernels which are of a dead, starchy appearance, with chaff adhering to them, or moulds, will probably not germinate at all. But one should always back up his judgment with the germination test.

The second question is: Will the corn mature? Will it ripen in the vicinity before frost?

Corn which is immature grades low on the market. It generally moulds more or less, and during March and April, when the corn thaws out, the germ of the kernels, which is the most valuable portion of the grain, turns black and thus reduces the feeding value. Late maturing

corn often does not have time to dry out before the severe freezes of November and December, and its vitality is injured. The indications of immaturity are: chaffiness and looseness on the cob, dull, starchy kernels with the chaff adhering to them, and shriveled or wrinkled tips. The germ of the kernels is doughy and of a cheesy color. Often the tip caps of the kernels break off upon the removal of the grain from the cob, leaving the germ exposed.

The third question is: Has the corn vigor and strength? Is it thrifty?

Ears having compressed butts with very small shank attachments, and ears with small pointed tips partly covered with small yellow or flinty kernels are constitutionally weak. Ears with a dull and starchy appearance, small germs and weak pointed tips are weak and will not



Fig. 4.—Kernels showing large and small germs, taken from different ears of corn. The two right kernels on the upper row show big germs and strong vitality. This is also true of kernels 13 and 14 of the lower row. The ears from which the other kernels came should be discarded.

endure unfavorable conditions. A large germ or heart in the kernels indicates not only strength and vigor, but also a high oil content.

The best indication of strength, however, is the way in which the kernels sprout in the germination box.

And lastly, the farmer should ask himself: Will this ear produce other ears like it and better? Is it true to type?

The ears to be selected for seed should be uniform in size, shape, and color. Any marked differences in the ears, such as a red cob in white corn, or a mixture of red and white, or blue and white kernels indicates cross breeding. Now, cross breeding with a definite purpose is a good practice. Most of our best corn varieties have been developed by this method. But in the case of random crossing, the corn tends to revert to older strains than either of its parents, and deteriorates by so

doing. Again, varieties differ in the time of maturing, so in mixed strains we find many stalks silking before the pollen is shed and others after it has disappeared. Even in the individual ear, when crossed by a different variety, we find kernels which mature later than others. These usually freeze and fail to grow when planted. There is a lack of uniformity in size and shape as well, which makes it impossible to secure an even dropping of seed by the planter. This means a poor stand and a reduced yield.

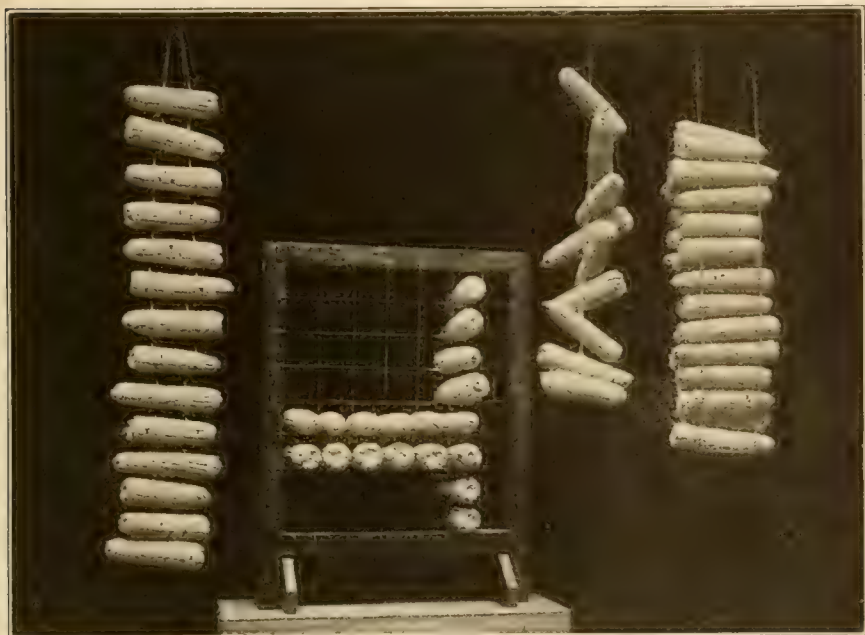

Fig. 5.—Four devices for curing seed corn. At the left the double cord is shown. The rack in the center consists of a square frame of 2x4-inch strips on each side of which wires have been stapled two inches apart each way. The ears of corn are laid upon these two sets of wires. Next is shown the single cord method of tying and at the right hangs a rack made of heavy wire in which the ears are laid.

Only that corn should be saved for seed which has a bright color and is free from chaff, moulds and blackened germs. Pointed tips and narrow germs should be avoided. Ears which display cross breeding in either form or color should be at once discarded.

Late varieties of corn should not be planted if it is known that they will not mature within the season common to the district in which planted. No seed should be planted which has not constitution and producing power. No seed should be planted which has not a creditable history of selection and improvement back of it. Breeding shows. We have only to use our eyes intelligently and judge carefully to take advantage of it.

Curing and Storage—After the best ears have been selected for

seed and set aside they must be cured or dried. Corn, when husked, contains considerable water which might freeze during the winter and kill the embryo. This is best removed by drying slowly in corn house or attic for several days where there is heat from a stove or furnace and free circulation of air. If all seed corn was properly cured there would be much less necessity for the use of the germinating test.

A common mistake is to place the seed corn in the sun against the south side of the house or barn, under the impression that it will dry more quickly. The rays of the sun will soon kill the germs in the kernels on the side exposed.

Corn can be cured by hanging for a time under a porch or cornerrib roof. It must always be brought in, however, before freezing sets in. The best and most common way to cure it is to hang it in the attic.

Figure 5 shows a few of the devices for storing and curing the corn. Another convenient method of storing and curing corn is by means of the corn tree. This can be placed in some corner of the attic or in one of the spare rooms of the house where there is a free circulation of air.

The corn should be protected from the ravages of rats and mice while curing and when in storage.

The chief advantage possessed by the corn tree is that every ear is separated from the adjoining ears and admits of better circulation of air than most other devices.

One of the best methods of storing seed corn is to string the ears as shown in Fig. 7. This keeps the corn from the reach of mice and rats, does not take up much space, and permits the circulation of air so necessary in drying.



Fig. 6.—This corn tree holds sufficient corn to plant 15 acres on the check row system. A smooth pole six feet long and eight inches in diameter is fitted with a base to hold it upright. Rows of long, headless finishing nails are driven into the post $2\frac{1}{2}$ to 3 inches apart. The ears of corn are thrust upon these nails and stand apart for curing.

Courtesy of the Wisconsin Experiment Station.

When seed corn is to be stored and cured in the attic or seed house, there should be a small stove in use

for the first week or two to furnish heat to dry out the corn. No one thing injures our seed so much as freezing, but by the use of maturing varieties, and by careful drying and storing in the attic, we can largely prevent the loss of vitality of our seed corn.

Testing Seed Corn—There is only one way to be sure that seed corn will grow, where it is not fire-dried and that is to ear-test it. Testing takes only a little work at a time when other labor is not pressing; and it often means the difference between success and failure

In the corn belt the time to test is between February 20 and March 20. In the South testing should be done somewhat earlier.



Fig. 7.—Tying Up Seed-Corn.

The actual process of testing is very simple. First the ears are laid out in long rows on the attic floor, or, better, on a long table. The ears which are mouldy and damaged by insects or which are too obviously worthless are then discarded, and the ranks filled up with better ears.

The rows are held in place by spikes driven in at the ends as shown in Fig. 8.

When the ears are in place they must be numbered. It is unnecessary to number each ear. Above every tenth ear a number is stenciled or chalked on the table or floor. Thus, 1 is placed above the first ear, 11 above the eleventh, 21 above the twenty-first, etc. Figure 9 shows this clearly.

The ears are now all turned tips in the same direction. From each ear six kernels are taken, one from the butt, tip and middle on each side. These are placed below each respective ear.

We are now ready for the actual test.



Fig. 8.—Taking the Kernels.

One of the best tests is obtained with the sawdust testing box. Build a shallow box twenty by forty inches by six inches deep. Place some sawdust in a sack and boil it in water to kill all germs and insects which



Fig. 9.—System of Numbering the Ears.

might interfere with the test. Let it soak over night in the hot water.

Too much water will make the sawdust cold and soggy, which will retard germination. Therefore the water should be drained off as shown in Fig. 10.

Fill the box half full of the moist sawdust and pack it down rather solidly with a brick. Then cut a piece of muslin to fit the box and mark it into two-inch squares with a lead pencil. Number each square to correspond to the numbers on the ears. Thus, if the ears run from



Sawdust Soaking.



Fig. 10. Draining Off Surplus Water.

1 to 21, number the squares from 1 to 21 also. Pull the cloth tightly over the packed sawdust and tack it to the sides of the box.

Take the six kernels extracted from ear No. 1 and put them into space No. 1 of the box. Do the same for ear No. 2 and No. 3 and so



Packing the Sawdust.



Fig. 11.

Tacking the Muslin.

on until the box is full. If there is more than enough corn for one box, make another, and number the squares accordingly.

When the testing box is full, turn all the kernels with their tips pointing toward one side of the box, cover them with another piece of muslin, and fill the box with sawdust. A muslin bag made to fit the box and filled with the moist sawdust is better.

Now tilt the box a little by putting a couple of bricks under it,

as shown in Fig. 13. Remember in which direction the tips were pointing, and let this side be the lowest. This secures drainage if the box is too wet, and the kernels, following the laws of nature, will send all their stems toward the upper edge of the box and their roots toward

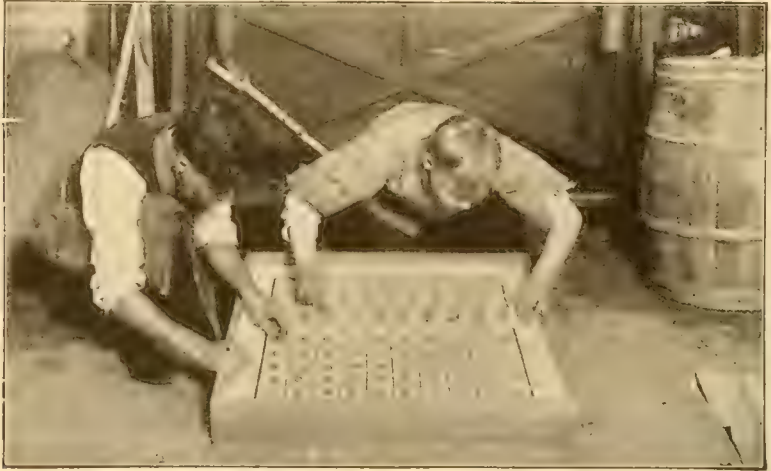

Fig. 12.—Placing the Kernels In the Germination Box.

the lower edge. This makes the test easier to read, since there is not the customary tangle of roots and stems which occurs in the ordinary box test.

The germination box may then be set aside, for three or four days.

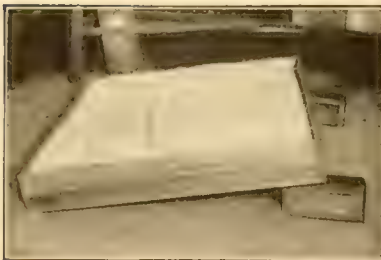

Fig. 13.—The Box In Position.

In the meantime the rows of ears left on the table must not be disturbed, as any change of position now would render the test worthless. The best way to hold the ears in place is to lay planks over them as shown in Figure 14.

How to Read the Test— In four or five days, when the sprouts from the most vigorous kernels are two or three inches long, the covering may



Fig. 14.—Planks Hold the Ears in Place.

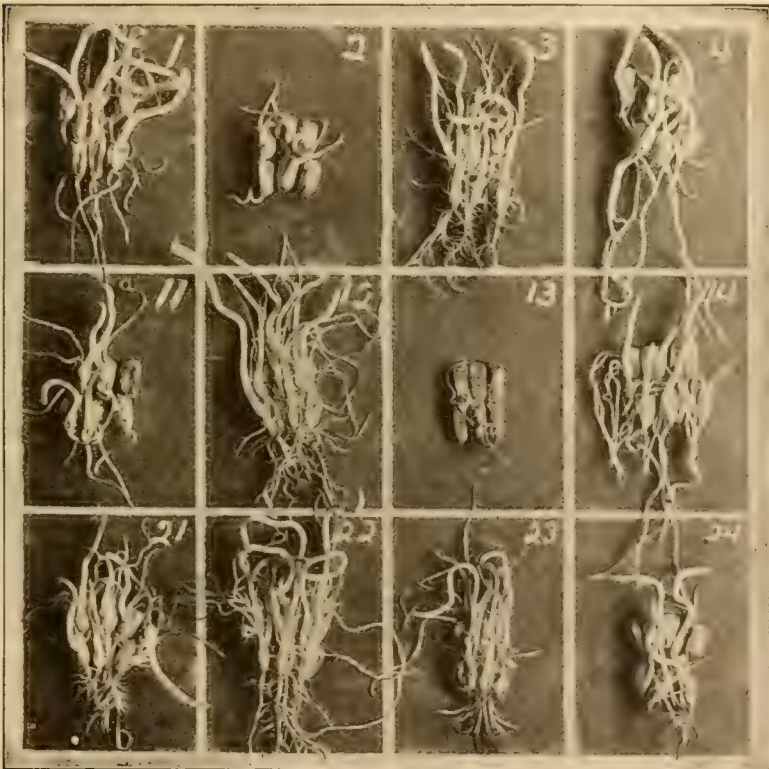

Fig. 15.—A Section of a Germination Box.

be carefully removed and the kernels examined. Ears 2, 11, 13 and 24 in Fig. 15 should be immediately removed and carried to the feed bin, for fear they might get mixed with the others by mistake. Ear 2 is



Fig. 16.—Discarding Weak Ears.

weak. One kernel has not sprouted at all, only swollen a little. Ear 11 shows one dead and one weak. Ear 13, six dead kernels. Ear 24, three dead kernels. Ears 21 and 23 are weak and slow and should be put to



Fig. 17.—The "Rag-Doll."

one side and not used unless absolutely necessary. Ears 1, 3, 4, 12, 14 and 22 show up strong and are now ready for butting and tipping. Ears like 2, which show some life, if planted will be behind all summer and probably produce little or no grain. The plants will produce pollen

and the tendency will be to reproduce its kind, causing the corn to deteriorate instead of improving. Wherever any kernels failed to sprout or produced only a weak growth, the number of that square should be noted and the ear bearing the corresponding number should be shoved out of line as shown in Fig. 16.

After the whole box has been examined these ears that have been shoved out of line should be promptly run through the corn mill and fed to the stock, to be sure that they do not get mixed with the good ears. It does not pay to plant kernels from dead or weakened ears.

While the dead and weakened ears are being noted and marked the farmer should also watch for the kernels having a markedly superior growth. Whenever good growth or germination coincides with very good shape and color of the ear, that ear should be saved for the seed plot.

It will be remembered that all the ears were turned with their tips in the same direction. Now, when one of these seed ears is met with, reverse its position, so that its butt end rests where its tip did before. Do not shove it out of line, or it will be taken up and discarded with the undesirable ears. Later, when the poor ears have been discarded, one can go over the rows and pick out the best ears as marked.

Another method of testing is with the "Rag Doll" tester. The "Rag Doll" is a piece of muslin nine inches wide and sixty inches long, marked off into two and one-half inch squares with indelible ink. Each square is numbered in the same manner as the squares in the sawdust box tester. The six kernels removed from ear No. 1 are placed in square No. 1, etc., until each square of the "Rag Doll" is filled. Six kernels are taken from each ear the same as for the sawdust test. These are all turned in the same direction, and the "Rag Doll" is carefully rolled up and tied with a string around the middle. It is then placed in a pail, with the points of the kernels pointing downward. When ten "dolls" have been placed in a pail, it is filled with lukewarm water, wrapped up carefully to conserve the heat and set aside to soak for six hours. The water is then drained off and the pail is covered with a damp cloth and allowed to stand for a couple of days. At the end of two days refill the pail with warm water and let it stand for five or ten minutes. Then drain the pail and set it away in a warm room for five or six days longer. The remainder of the test is the same as with the box tester.

There are a number of patent testers manufactured, but they do not have any material advantages over these two home-made testers.

Shelling and Grading—Each ear of seed corn should be shelled by itself and carefully examined before being mixed with the other seed corn. If it does not come up to standard it should be discarded. The butt and tip kernels must always be discarded, as their small size makes planting irregular and reduces the stand. A shallow box, or better, a screen which will allow the top and butt kernels to fall through should be used in examining.

All damaged and diseased kernels can thus be found and removed. At the same time the corn can be graded into four classes: large size,



Fig. 18.—Grading the Kernels

first and second grade according to quality, and small size, first and second grade. This can be done either by hand or by screen, but the



Fig. 19.—Testing the Planter.

screen makes only two distinctions, large and small sizes, and it will be necessary to regrade by hand according to quality. The best quality large-size grains takes precedence over all the other classes of course.

When this is used up the planter should be regulated and the best quality small-sized kernels planted.

After some fifteen ears of corn have been shelled, test out the planter, using the different plates and different grades until the planter is dropping the required number of seeds per hill and dropping them regularly.

Then grade the corn so that the kernels are the best size for the planter, regrading if necessary. It does not take more than a couple of hours to test out the planter and a much better yield is insured.

When a seed plat is run in connection with the corn field, it is best to save the kernels from the one hundred best ears for use on the plat. These can be stored in white bags, as shown in Fig. 20, while the rest of the seed corn is stored in ordinary gunny sacking. This keeps the seed from getting mixed at planting time.



Fig. 20.—Ready for planting time.

THE CULTIVATION OF CORN

Plowing — Fall plowing produces the best results if followed by proper cultivation in the spring. It is a mistake to leave the fall plowed ground in the spring without disking until planting time, because much of the moisture is lost from the soil, and the corn is in danger of "firing" in August when the dry weather comes on. Fall plowed ground should always be disked or harrowed as soon as the ground works well in the spring. If the ground is left to bake it not only loses moisture but will be in a condition where good tilth cannot be acquired.

Fall plowing has several advantages. Having the ground already plowed in the spring gives us more time to cultivate properly. If done early in the fall, it prevents most weeds from seeding and brings the weed seeds lying dormant in the ground to the surface where they will sprout and be killed by fall freezing.

Stubble ground should be plowed early in the fall to kill the weeds. Sod ground, on the other hand, should be plowed late. This gives the benefit of a late summer pasture, and in the case of clover a second crop for seed. By plowing the sod land late, we can put manure on the sod in August and September without danger of loss from leaching. Grub worms that inhabit sod land are readily killed if the plowing is done in the fall. It breaks their cells and exposes them to the weather. Hogs will gorge themselves on white grubs, and should be turned into the plowed field.

Ground that is very rolling and likely to wash should not be plowed in the fall. With spring plowing one should never leave the field at night without harrowing the ground that has been plowed during the day. This prevents baking and drying out.

Depth to Plow—Deep plowing is not advisable in the corn belt, although loose soils and bottom lands may be plowed much deeper than black prairie soil. Plowing should not be deeper than 8 inches either in the spring or fall. On heavy soils that are not well drained the bad results of too deep plowing are apparent for several years from the effects of puddled soils and diminished yields. On well drained heavy clay soils, deep plowing is to be preferred where it can be done in the fall and the land left in the rough over winter.

Early Cultivation—The fall-plowed land and unplowed corn stubble should be disked and harrowed as early in the spring as possible. This forms a fine dust mulch which conserves the moisture. The most important result of early cultivation is the conservation of moisture which will be needed later on, the lack of which will mean fired corn in August. A half-prepared seed-bed means a poor stand of corn and an uneven growth.

Planting—One of the secrets of success in corn growing is readiness when spring comes. Where the ground has been plowed in the fall and cultivated as soon as possible in the spring, the farmer is ready to plant at the first opportunity. Many farmers who prepare their land in the spring are unexpectedly delayed by sick horses, or lack of help, or bad weather, or a combination of all three. The result is that they cannot get their corn in until too late. The ground has become hard and out of condition and the weeds have drawn heavily upon the moisture and fertility of the soil. The corn comes to the dry season in a critical stage, and the result is a partial or total failure of the crop. The grower who expects to make a success with corn must get it in at the right time.

Depth to Plant—When the ground is not well prepared, or is very mellow the planter wheels frequently sink into the earth a couple of inches. The corn is then planted 4 inches instead of the regulation 2 inches. When the field is harrowed, another inch is added to the covering of the seed. The corn cannot grow when covered to such a depth.

It sprouts, but dies long before it reaches the surface. Whenever a mellow soil is to be planted, the farmer should watch his depth, and reduce the drills to an inch or even less if necessary, for harrowing will fill the wheel tracks and put the corn plenty deep enough.

On the other hand, when the ground is dry and lumpy or mealy, as is often the case when spring plowing is not immediately followed by harrowing, the corn should be planted 4 inches deep. At 2 inches there is not enough moisture for proper germination. The seed soaks up slowly, much of it sours or rots, much more of it dries up, and the remainder comes up unevenly with a large number of weak and sickly plants.

Great care should be taken not to plant too deep on cold, wet, or heavy soils. Two inches is the limit for corn if the soil is heavy, or if the spring is cold and backward so as to slow up the process of germination. On loose soils a plunker or roller should be used to put the ground in better condition to plant at a uniform depth.

Checking — Checking corn is to aid cultivation by permitting the cultivator to be run both ways through the field. If the planter has been handled carelessly, the checking will be uneven, and much trouble will follow in cultivation. Uneven checking is due to several causes. On short fields the wire may be drawn too tight, when the planter will check too quick both ways. On long fields, too much slack is usually given the wire, and the planter checks ahead of itself. Where fields are irregular, a jog appears every four rows. Carelessness in setting the anchor and tightening the wire are the two chief causes of irregular checking. A little care in checking, the farmer should remember, will save a great deal of trouble in cultivation afterwards. When the field is once checked unevenly it cannot be remedied.

Cultivation — A few days after planting the field should be harrowed and if it is weedy it should be harrowed again before the corn appears above ground. There is little danger of uprooting the seeds that have already sprouted if the teeth of the harrow are given the proper slant.

It is best to cultivate once each week or every ten days while the plants are small, thus making a fine dirt mulch and keeping the weeds from getting a start. The first cultivations should be deep and as close to the hills of corn as possible. When the corn gets to be a foot high the cultivator must be set out from the hill about six inches on each side and not set deeper than two to three inches. If this precaution is not taken the roots will be torn off and more damage than good will result. However in a dry climate the roots go somewhat deeper and the cultivator can be set from three to four inches without danger to the roots. When the plants get so large that the two-horse cultivator cannot be used, cultivation can be suspended altogether. At this period a great deal of moisture is conserved by the shade that the corn plants cast and there is considerable danger of severe root pruning if cultiva-

tion is continued. Even if the weeds should get a start, they will do less damage than the root pruning of the cultivator.

Harvesting—Harvesting should be done when the lower leaves of the corn plants have begun to turn brown and the corn is well dented and glazed. The corn horse is a handy device for shocking. It consists of a pole about fourteen feet long supported by two 6-inch boards nailed to one end of it, braced by a cross-piece. About two feet from the supported end a hole is bored through the pole, in which a broom handle is fitted loosely. The device stands about three and a half feet high.

In shocking, the plants are set up in the four corners made by the broomstick and pole. After tying the shock, the broom handle cross-piece is removed, and the horse is drawn out and set in position for the next shock. This minimizes the effort used in placing and tying the shocks and is a very convenient device for use in the field. The corn harvester is now used quite generally, and corn is bound at the time of cutting. This machine is a great labor saver.

Rotations—Where the same field is cropped to corn year after year, the yield becomes less and less until it ceases to become a paying crop. The only way to prevent this is by applying manure or other fertilizers, or by planting other crops in the field, growing corn only once in two or three years.

Corn is a cultivated crop relatively free from diseases, and so it should follow crops which are liable to leave the soil infested with diseases. The usual rotation is corn after pasture or hay. Corn requires rather rich land and if it follows pasture, manure can be supplied it by manuring the pasture in the fall. Corn following clover pasture or a mixed hay crop is preferable. The clover crop aids in destroying the cutworm and weeds which might do considerable damage to a grain crop. Clover should be grown at least one year in four.

A three-year rotation of corn, wheat, barley or oats, and clover is a good one in the corn belt. Where there is much trouble with weeds, sugar beets, potatoes, or some other cultivated crop may be added. In the South a common rotation is pasture, corn, cowpeas, and cotton. In general, corn should follow a pasture or a leguminous crop, and because it leaves the soil in good shape, it should be followed by a grain crop.

CHAPTER II.

WHEAT

I. SOILS. II. PREPARING THE SEED-BED—PLOWING—FALLOWING—TREATMENT AFTER PLOWING. III. SEED. IV. PLANTING—TIME—DEPTH—AMOUNT OF SEED TO SOW—METHOD OF SOWING. V. SPRING CULTURE. VI. HARVESTING—TIME—SHOCKING—THRESHING. VII. FERTILIZERS. VIII. ROTATIONS.

Soils—The character of the soil affects the yield of wheat as much as the quality of the seed. An ideal wheat soil is one of good drainage, medium to fine texture, and high fertility. Wheat does best on heavy loam and clay soils. This is due to its well developed root system, which enables it to secure plant food under adverse conditions. It is on wet heavy soils that "heaving" and winter killing do the most damage. For this reason it is always best to plant on moderately high and dry land.

Preparing the Seed-Bed—Land for winter wheat should be plowed as soon as the previous crop has been taken out. Late plowing, especially when the land is dry, or when a large amount of organic matter must be turned under, should always be avoided. Early plowing gives the soil time to settle, and in dry climates gives a fallow for six weeks in which to kill the weeds and conserve the soil moisture by harrowing. The old adage that "July plowing is best for winter wheat" can, as a rule, be safely followed.

Excessively deep plowing for winter wheat, such as eight or ten inches, is not advisable, even when done early. Six or seven inches is sufficient depth for most soils. Where wheat follows corn on mellow soils it often does not pay to plow at all. Cultivation with a disk harrow is all that is necessary.

Fallowing—In Kansas, and throughout the semi-arid belt as far as northern Manitoba, summer fallowing is practised. The land is harrowed after each shower, and plowing is done in the spring rather than in the fall. This conserves the moisture and puts the land in excellent condition for winter wheat. Care must be used to divide the land into long narrow fields running at right angles to the prevailing winds and protected by hedge windbreaks between the fields. This prevents the soil from drifting out of one bed and covering the next. (See Dry Farming).

Treatment of Seed-Bed After Plowing—It should be borne in mind that wheat requires a loose seed-bed at the surface, but a compact and well-settled one beneath the surface. On loosely packed soils the soil particles are more or less widely separated and the soil water cannot

be raised to the surface by capillary attraction. Although there may be a good supply of water in the ground, it cannot reach the germinating seeds which may dry up, producing an uneven stand. If the soil is compact, on the other hand, and the surface is not loose or mulched, most of the soil water will be lost by evaporation and the wheat will come to the dry period without a sufficient water supply. To secure this loose surface, wheat land in the semi-arid regions should be disked immediately after plowing. Heavy rains after plowing will usually compact the soil sufficiently, and a few weeks should intervene between plowing and seeding to give the ground time to settle. After each rain, a harrow should be run over the field to break up any crust that forms and check evaporation. If the weather is very dry, it may become necessary to roll the field to secure the proper compactness, especially if a large amount of vegetation has been turned under. The harrow should always follow the roller, thus forming a mulch to prevent evaporation.

Lumps are not desirable in a spring wheat field, as they are apt to interfere with the drill or seeder and cause an uneven stand. They are not so objectionable, however, on a winter wheat field, as they help to hold a covering of snow, thus preventing freezing and thawing of the soil, and at any rate they are split up and pulverized by frost and weathering.

The Seed—Good seed is essential. Only seed which is plump and uniform in size should be planted. It should be carefully fanned to remove shrunken and immature grains, for these cause a material loss in the crop. Many farmers believe that wheat seed “runs out” and that the seed must be replaced from time to time. This idea is wrong. Wheat seed does not run out unless the farmer becomes careless in selecting his seed, and plants seed which he cannot sell profitably. There is small hope for a good crop from poorly selected seed. Nevertheless, the seed must not be judged as poor because the crop is inferior in certain years. The failure may be due to unfavorable climatic conditions or to the ravages of disease and to no fault of the seed. Another year this same seed might yield a bumper crop.

Therefore, the farmer should think carefully before discarding his own seed for new and untried varieties. The first few yields of any new variety, not adapted to the section, are bound to be below the average; because the plants must adjust themselves to their new environment. And there is always the chance that the new variety may not become adapted at all. Careful fanning and selection of the plumpest and most mature seed will do more towards preventing the so-called running out than all the seed importations put together. Plant only the best seed from your fields. If you have seed which cannot be sold at a profit, feed it to the stock, but don't sow it.

Sowing—Early sowing of wheat is usually to be preferred. The more fertile the soil is, the later the seeding may be done safely, as rich

soil produces the growth in a shorter time. When fall wheat is sown too late, the wheat plants have not enough vitality to withstand cold weather.

In some localities, fall sown wheat is subject to attack by the Hessian fly. Where these pests exist, the seed-bed should be put in the best condition, and the wheat planted the moment they disappear. This time varies in different localities, and inquiry should be made of the State Entomologist. Winter wheat can be planted too early in the fall. If the plants grow large and are about ready to "shoot" before winter sets in, severe freezing weather will probably kill them. Enough growth should be made so that the leaves will serve as a mulch to the roots, and the root development should be strong enough to prevent heaving.

Spring wheat should be sown as early as the season permits. When the heavy spring rains have destroyed the mellowness caused by frost action, heavy soils are apt to puddle and spoil the stand. If it is possible to get on the land before it has been settled by the spring rains, much less work will be required to get it into condition for seeding, and the seed may be sown as soon as the ground is dry enough to work well.

Time of Planting — Spring wheat should be planted from the middle of April in the north central states, to the middle of May in Ontario and Quebec. Winter wheat should be planted from the middle of August to the middle of September.

Depth to Plant — The depth at which the seed should be sown varies with the moisture content and the firmness of the seed-bed. Wheat should be sown deeper in dry soil than in wet, and in warm sandy soil than in the colder clay. One to three inches represent the extremes in sowing, and it is never safe to go beyond them. Deep planting is not proof against winter killing. Where the seed is planted more than two inches deep it delays the growth of the upward shoot. The root system should be thrown out from this shoot at a point something less than two inches beneath the soil surface, and on top of the moist soil beneath the mulch. The best depth to plant, then, is at about two inches.

The Amount of Seed to Sow — The amount of seed to sow is about 5 to 6 pecks per acre. For late seeding, 7 pecks is better. In late seeding, there is bound to be some loss from drought and this loss must be made good by sowing slightly more seed than would normally have been used. It should always be remembered that the size of the kernels partly determines the rate at which grain must be sown. For varieties having large kernels, the gauge should be opened wider than for varieties having small kernels to secure the same stand.

Methods of Sowing — As a rule, winter wheat sown in drills will out yield that sown broadcast. This is explained by the fact that many of the broadcasted plants are sown too shallow. Their roots lie too

near the surface, and when the snow blows off, they are at once frozen and killed, or if they do live they are not properly nourished.

For broadcasting, seeders are the best to use. But sowing with the drill is to be preferred on well tilled land for several reasons. In the first place, less seed is required to secure a good stand, and in the second place the drill puts the seed down to a more uniform depth, thus securing a more uniform stand.

It is a common practice on the Mississippi valley loams to drill winter wheat without plowing. A harrow is dragged between the corn

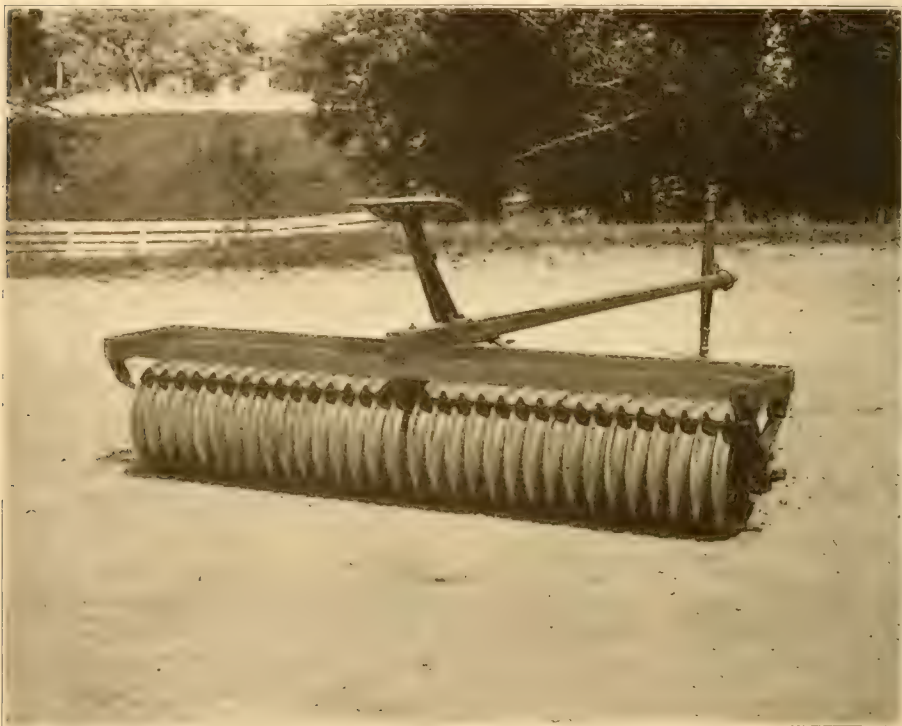

Fig. 1.—The Corrugated Roller Gives Better Results Than the Old Flat Type
Courtesy of the Iowa Experiment Station.

rows to destroy the weeds. Then the wheat is sown between the rows by means of a five-hoe grain drill. Afterwards, at the proper time, the corn is husked, and in the winter, when the ground is frozen, the corn-stalks are broken off with a heavy drag or planker.

In sowing clover, alfalfa, or grasses with spring wheat, it is better to let the grass seeder attachment sow broadcast, than to run these small seeds through the grain spouts. Otherwise the small seed may be covered so deeply that it will not come up well.

Spring Culture — Where the ground is compact and hard from the

beating rains of early spring, followed by rather dry weather, the harrowing of wheat is a good practice, especially if the plan is to put in grass seeding in the spring with fall-sown wheat. Where moisture is the limiting factor in production, it is well to go through the wheat with a weeder or harrow to establish a dirt mulch.

Where wheat is badly heaved the use of a heavy roller in early spring is advantageous.

The roller should never be used on heavy soils, or on wet soils. It will produce puddling.

Harvesting — To secure bright, sound, high grade wheat it is necessary to harvest the crop as soon as it is ripe. It is better to cut the grain before it is quite ripe than to wait until it is fully ripened. This is particularly true of the spring varieties.

The wheat should be shocked and capped at once after harvesting. The capping of a shock is a most important process, since this keeps out the rain and prevents moulding. One way to build a shock is to place three pairs of bundles in a row, and two bundles on each side. One bundle is laid on top, another bundle is broken, the ends are spread out fan-wise, and it is laid across the top bundle. This keeps out the rain and prevents the spread of fungus diseases through the shock.

Wheat should not be threshed directly from the shock. As soon as the grain is dry it should be stacked, or better, stored in a barn or shed. When wheat is allowed to sweat in the stack or barn for five or six weeks, its color and quality are both much improved. If threshing must be done shortly after stacking, or directly from the shocks, the threshed grain should be spread out in a thin layer over the barn or granary floor, and allowed to sweat there a few days before it is stored in bins. This will prevent heating in the bins or binburning.

Fertilizers — Wheat responds at once to the use of commercial fertilizers. This is most striking in the cases of nitrogen and phosphorus fertilizers. It does not seem to require special potash fertilizers. On soils derived from limestone steamed bone meal, applied at the rate of 150 pounds to the acre is good. On light sandy lands, 150 pounds of a complete fertilizer, say four per cent nitrogen, ten per cent available phosphoric acid, and four per cent potash will produce good results. The farmer must choose his fertilizer according to the needs of his fields. These fertilizers have been selected for immediate returns. It must be remembered, however, that the use of commercial fertilizers alone will not maintain soil productivity. They should be used only in connection with a system of crop rotation which includes the growing of alfalfa, clovers, cowpeas, vetches, or soy beans, and the application of manure to maintain the organic matter in the soil. In this case, either rock phosphate, applied at the rate of 600 to 1,000 pounds per acre before corn every five years, or acid phosphate, applied with wheat at the rate of 200 pounds per acre is to be recommended. On land of poor or average

fertility, fall wheat should be top dressed with manure in late winter or early spring, at the rate of from four to five tons per acre.

Rotations — Wheat is the exhaustive crop of most rotations. It usually follows corn or root crops and is the ready money crop.

A good rotation for heavy soils is as follows:

First year — Spring wheat seeded to clover and timothy.

Second year — Clover hay.

Third year — Mixed hay.

Fourth year — Cultivated crop (corn, beets, or potatoes).

Manure is applied on the sod either before or after plowing. Corn or some other cultivated crop is then planted, and the following year the land is sown to wheat. This rotation is not suitable for winter varieties of wheat, because the cultivated crops are not harvested early enough to permit of fall sowing unless the wheat is sown between the rows before the corn is harvested.

A good rotation for winter wheat is:

First year — Winter wheat, seeded to clover in the spring.

Second year — Clover.

Third year — Cultivated crop.

Fourth year — Peas.

On new land the following rotation is good:

First year — Winter wheat, seeded to clover in the spring.

Second year — Clover.

Third year — Mixed hay.

Another one is:

First year — Corn.

Second year — Barley or oats.

Third year — Clover hay.

Fourth year — Hay or pasture.

Fifth year — Winter wheat. (Manure the wheat stubble.)

The advantages of this rotation are that the winter wheat is grown on good rich soil, and that it does not have to follow another small grain. It has the disadvantage of compelling the farmer to plow his pasture early, thus losing a second crop of hay and a fall pasture.

Here is a rotation designed for farms given over to grain production almost entirely:

First year — Corn.

Second year — Oats or barley, seeded to clover.

Third year — Clover.

Fourth year — Winter wheat, seeded to clover.

Fifth year — Clover. (Manured.)

Clover, coming twice in a five-year rotation and supplemented by proper applications of manure, will properly maintain the fertility of the soil.

In case one should choose the following rotation, it is advisable to

fertilize the ground before plowing, or to add top dressing to the winter wheat. Such a rotation is not to be recommended unless the soil is in good productive condition.

First year — Corn.

Second year — Oats or barley. (Manure applied on stubble.)

Third year — Winter wheat. (Seeded to timothy and clover.)

Fourth year — Clover.

Fifth year — Hay or pasture.

For the corn belt the following rotation is recommended:

First year — Corn.

Second year — Corn. (Disked in the spring.)

Third year — Wheat, oats, or barley, with clover seeding.

Fourth year — Clover. (Manure and plow in the fall.)

CHAPTER III.

OATS

- I. SEED SELECTION. II. PREPARATION OF THE SEED-BED. III. PLANTING—METHOD—RATE OF SEEDING—DEPTH—TIME. IV. CULTIVATION. V. HARVESTING. VI. ROTATION.

Seed Selection—Many farmers put off oat selection until spring, and then simply go to the bin and shovel out the oats as they come, sowing both good and bad. This is a poor practice. All seed oats should be heavily fanned before planting to remove weed seeds and light-weight grain. Grain that is light of weight is usually run out, and is distinguished by pointed grains and by a lack of lustre and color. Black oats do not retain their glossy coal-black, but become reddish brown in color. White oats usually take on a greyish tinge when run out.

When a strain of oats has run out, as is usually indicated by light weight, it should be replaced by another and different strain. In the South it is customary to replace run out strains about once every four years with northern grown strains. In the North there should not be so much trouble from running out, but whenever oats show much light weight, they should be at once replaced.

The selection of large, bright colored, plump, well-filled seed oats year after year will prevent running out and bring a steady increase in both yield and quality. Heavy fanning is the quickest and best way to secure a good grade.

Preparation of the Seed-Bed—Oat ground should be plowed in the fall and disked and harrowed as soon as the land becomes workable in the spring. Land plowed in the fall makes a more compact seed-bed and is not dried out as readily as spring plowed land. Where oats follow the corn crop in the rotation, and the corn has been kept free from weeds and the soil is mellow, a good double disking in the fall of the year and again in the spring should be sufficient without a plowing.

Method of Sowing—Oats may be broadcasted or drilled. Larger yields can be obtained by drilling. This is probably due to better germination conditions, the roots growing at once into moist, fine soil and producing strong, thrifty plants. A disk drill should be used in planting, if possible, because it acts as a cultivator and will cover the seed, especially when running through corn stalks.

When drought occurs before or just at seeding time, drilling is preferable. At such a time broadcasting fails to allow sufficient covering.

and does not put the seed in reach of water. The result is that many of them dry up, and the stand is uneven. Under the ordinary conditions, broadcasting is cheaper and easier than drilling. But drilling produces the best yields. It is a matter of comparative costs and returns which the farmer must decide for himself.

Rate of Seeding — The rate of seeding depends upon the character of the soil. There is no definite rule as to how many pecks should be sown per acre, but 8 to 10 pecks is a good amount to sow.

Depth of Seeding — Oats should be covered from 1 to 3 inches deep, depending upon the character of the soil. When the soil is heavy, 1 inch is sufficient, but on light, dry and friable soils, where the soil moisture lies some distance beneath the surface, oats should be covered from 2 to 3 inches. Dry soils require deeper seeding than moist soils.

Time of Seeding — Since oats require much moisture and a cool climate for their best development, they should be sown as early in the spring as possible. They do not do well when the weather becomes hot. Commencing in Missouri in the last week of February, sowing becomes later and later as we go North and East. In Kansas, oats should be sown in the second week in March; in Illinois, in the last week in March; in Pennsylvania, the second week in April; in Manitoba, the first week in May; and in British Columbia, the third week in May.

Cultivation After Sowing — Cultivation after the oats are up cannot be considered a good practice except where the land is badly crusted after a rain. Cultivation to kill weeds is permissible in badly infested fields before the oat plants have appeared above ground. Thereafter they will crowd out most weeds that may come up.

In case the land is loose as land plowed in the spring is sure to be, rolling is very beneficial as it insures a firm seed-bed which is essential with small grain. The corrugated roller is best to use, if it is heavy enough to do its work. (See Dry Farming).

If the land is wet, it should not be rolled, as rolling would pack it too hard and prevent air circulation, and so hinder the growth of young plants.

Harvesting — Oats may be cut in the hard dough stage, and cured in round shocks. The sheaves should be shocked immediately, and capped, to permit slow ripening and sweating. Oats may be cut when half the leaves are still green, and the grain is in the early dough. When used for hay, oats should be cut in the milk stage with a mowing machine, and treated as any other hay crop. It is somewhat hard to cure oat hay.

Rotations — Oats fill in the gaps in rotations. They are sown early and are out of the way when other crops must be sown. They require no attention during the growing period, when the farmer is busy with his corn, cotton, or tobacco. And they are harvested before these other crops demand attention. Oats are a very nutritious feed for horses and

young stock. Oats is not as good a crop for seeding down meadows as wheat, rye, and barley, but it is used successfully as a nurse crop in favorable seasons.

Some good rotations are:

For winter wheat sections —

First year — Maize (Corn).

Second year — Oats.

Third year — Wheat.

Fourth and fifth years — Clover and timothy.

For maize sections —

First year — Maize.

Second year — Maize.

Third year — Oats with clover and timothy seeding.

Fourth year — Red clover hay. May be extended to fifth year and run to pasture if much livestock is kept.

For southern states —

First year — Maize and cowpeas.

Second year — Oats, followed by cowpeas.

Third year — Cotton.

Fourth year — Cotton.

CHAPTER IV.

BARLEY

I. THE SOIL. II. PREPARATION OF SEED-BED. III. ROTATION. IV. TESTING AND SOWING SEED. V. CULTIVATION. VI. HARVESTING—SWEATING.

The Soil—It is useless to try to grow barley upon poor sandy lands or worn out soils. It does not do well when the soil is in poor tilth or badly drained. Neither does it grow well on newly cleared land. Barley requires a rich soil, mellow and well subdued, with the fertility near the surface. For this reason, barley should be grown on land that has been in a high state of cultivation for a number of years, and that is in a high state of fertility.

Preparation of the Seed-Bed—Barley is a shallow feeder, its roots growing near the surface of the soil. Deep plowing is advisable on clay soils if done in the fall. If the plowing is done in the spring it should not be any deeper than the ground has been previously plowed.

The soil should be gone over several times with a disk and fine-tooth harrow before sowing, to prepare a mellow and smooth seed-bed. It is also necessary to prepare a dirt mulch when the season promises to be dry, as barley roots are shallow, and consequently the plant suffers severely in drought.

Rotation—In rotation barley follows corn, peas, potatoes, or root crops to good advantage. It is one of the best of nurse crops with which to seed down clovers or mixed grasses, because it uses less water than oats or wheat, its shallow root system does not draw heavily on soil fertility, and it is removed from the land early.

Testing and Sowing Seed—All barley seed should be tested by the method discussed in Chapter VII, Book I. The vitality of barley is quite easily injured by heating in the stack or storage bin, and it is never safe to use without first testing. If the seeds do not test as high as 90 per cent germination, they should be regarded as inferior and should not be used as seed.

Barley should be seeded later than either oats or spring wheat, as it is more readily injured by late frosts than the other small grains. A drill or broadcast seeder is commonly used and the barley is sown at the rate of from one to two bushels to the acre. When it is desired to seed the land down to clover or to timothy, only from one to one and one-half bushels are used.

Cultivation—Barley is seldom tilled. It grows so thick and fast that the weeds are crowded out, so cultivation is unnecessary. This accounts for the response which barley makes to thorough preparation of the seed-bed. Carelessness in preparing the seed-bed allows the moisture to escape by evaporation. It cannot be retained by cultivation after the crop has once been sown. So if the soil moisture has once escaped, the growth is stunted, and the crop damaged.

Harvesting—Barley should be cut with the harvester when it is well ripened, and the straw and heads are of a golden yellow color. The kernels should be in the hard dough stage. If the barley is cut when the straw is yet green the kernels will shrink and turn ash colored, which is undesirable.

A harvester with the bundle attachment is to be preferred, because barley shells easily with much handling, and it is desirable to harvest it with as little handling as possible.

Shocking should be done on the day of harvesting. If barley is exposed to rain, sunlight, and dew, its color and vitality are damaged, and its market value, therefore, decreased. Put up shocks, using eight bundles to a shock and two more bundles for caps. This form of shock has been shown by experiments to protect the barley most from weathering.

The length of time that barley is to be left in the shock depends upon the weather, the ripeness of the crop when cut, and the weeds which may be bound up with the barley. It should remain in the shock long enough to dry pretty thoroughly, and may be covered with hay caps in wet weather as a protection against rotting and moulding.

Sweating—Lack of sufficient help at harvest time has caused many farmers to thresh directly from the shock. This practice does not permit the barley to go through certain processes known as sweating while on the straw. It will then sweat in the bin, and the temperature may rise sufficiently high to injure the quality of the grain. This deterioration can never be overcome, and lowers its market value.

After the barley has been left in the shock until it has sweated and become thoroughly dry, it may be safely threshed, but the grain should be spread out about a foot deep on the floor of the grain bin and shoveled over occasionally until the sweating process has completely ceased. This prevents the grain from heating as it would do in the bin. After several days, or perhaps a week, the barley may be removed from the floor and safely binned. A little care in handling will more than repay the farmer for his trouble.

The best method, however, is to leave the shocks in the field until thoroughly cured, and then haul them into the barn, or stack them. The grain should be left in the stack a month before threshing. There will then be no danger from sweating in the bin.

In stacking the bundles, the cap sheaves should always be removed

while hauling and placed in a separate stack. They should be threshed separately, because many of the heads have become weathered and discolored, and their mixture with the rest of the grain would be sure to lower its selling value.

CHAPTER V

RYE

I. SOILS. II. PREPARATION OF SEED-BED. III. SOWING THE SEED. IV. CULTIVATION AND CARE. V. HARVESTING. VI. ROTATIONS.

Soils—Rye has sometimes been called the “grain of poverty,” because it is better adapted to poor soils and unfavorable climates than any other cereal. While rye will thrive on poor soil, and on light, sandy land, it should not be assumed that it does best on that kind of soil. Rye will respond as readily to good tillage and good soil as any of the grain crops. A black loam, or a clay or sandy loam is particularly favorable to the crop. For economic reasons, however, it is advisable to plant rye on land which cannot be used so well for anything else.

Rye requires good drainage for its successful cultivation. It should never be planted on river bottoms or lowlands without providing proper drainage.

Preparation of the Seed-Bed — The seed-bed should be prepared by plowing the land as early in the summer as the previous crop can be removed. The first of August is not too early in the northern states. The plowed land should be compacted and reduced to a fine tilth before it has had time to dry out. For this reason the land should be gone over with a disk or harrow the same day it is plowed. The soil should be harrowed once a week and after rains until planting, to prevent the growth of weeds and conserve the soil moisture.

Sowing the Seed — Rye seed may be sown either with a seeder or drill. The broadcast seeder is the best to use on stumpy rough land. The seed should be sown from 2 to 2½ inches deep.

Amount of Seed to Sow — For a grain crop 13½ bushels should be sown per acre. The amount varies with the size of the seed. Where the crop is desired for fall pasture, from 1½ to 2 bushels per acre should be sown.

Time of Sowing — Fall rye may be sown at any time between August 20 and September 25, depending upon the location and use of the crop. For fall pasture, it should be sown between August 20 and September 10, the earlier seeding being preferable. For grain only, from September 1 to 15 is the best time to sow. The sowing of the crop should never be delayed beyond September 25. Spring rye is sown in the early spring. The ground is prepared and the seed sown like barley, wheat, or oats. Spring rye has not become very popular because of its low yields, and the fact that it competes for the farmer's time with more profitable crops that can be sown in the spring.

Cultivation and Care — On land that is likely to be dry, it is a good

practice to harrow the land immediately after it is plowed, forming a dust mulch. This conserves the soil moisture, saving it until the dry weather when the plants need it badly.

If the crop has been sown early for pasturage in the fall and is to be left as a grain crop, it should not be allowed to form heads in fall growth. This can be prevented by close pasturage.

After sowing, rye will need but little care until harvest time. If sown thickly it makes a rapid growth which is dense enough to crowd out any weed which may appear.

Harvesting — Fall rye ripens slightly earlier than wheat or barley, in the northern states usually between the 10th and 25th of July. It should be handled with the self-binder the same as the other small grains, and shocked in good sized round shocks. To prevent weathering and discoloration, these shocks may be covered with canvas caps, especially in wet weather, when they are liable to mould.

Ordinarily the grain is threshed out the same as other grain crops. But where there is a demand for straight rye straw, special threshing machines have been devised which keep the straw straight during threshing, and do not break it badly.

Rotation — Ordinarily, rye takes the place of wheat, oats, or barley in a rotation. It is a grain crop and makes demands for the same class of elements as the other grain crops, with the same effect upon the soil. It is one of the best crops with which to seed down land to grass or clover in the spring, because it is removed very early in the season.

CHAPTER VI

SORGHUM

I. THE SOIL. II. THE SITE. III. PREPARATION OF THE SEED-BED. IV. PLANTING—
DEPTH—AMOUNT OF SEED—TIME. V. CULTIVATION. VI. HARVESTING.

The Soil — As a rule land that will produce a good crop of corn will also produce sorghum. Soils that are stiff, and that have a tendency to bake should, however, be avoided. Clay loams or sandy soils are good, and better if they contain a fair amount of lime. Upland soils with a limestone subsoil produce very well. Sorghum may be planted on new land, but does better on land having a few years' cultivation. The essential thing is that the soil be deep, porous, and well-drained.

The Site — Fields that are to be planted to sorghum should be in a rolling country to insure good drainage. Poor drainage means an abnormal growth of suckers, and a consequent loss in value. A southern or a southeastern exposure should be selected where possible to give the plants the benefit of sunlight and protection from the cold, northerly winds. Sorghum suffers badly in windstorms. Its feeding roots are not long enough or strong enough to anchor it well, and it lodges badly. In places where there is much wind it is a good plan to plant a windbreak of corn or trees (if a permanent one is needed) between the field and the prevailing winds.

Preparation of the Seed-bed — A good seed-bed may be secured by fall plowing. This should be deep and thorough, and the bed should be leveled off with a harrow in the early spring to prevent evaporation before sowing.

Manuring — If manure is to be applied, it should never be fresh. The young plants are small and delicate, and will be injured by fresh manure. Compost all manure for a year before applying it to the sorghum bed. An excellent method is to compost the manure with raw phosphate rock at the rate of 200 pounds of crushed phosphate to the ton. This serves the double purpose of hastening the rotting of the manure and transforming the crude phosphate rock into its more available forms.

Planting — Sorghum is planted in rows, spaced at from three to four feet according to the richness of the soil. The plants in the row should be spaced at from 6 inches to 2½ feet, depending upon the character of the soil. Rich soil should be more closely spaced than poorer soil, because it can produce more. Sorghum is usually spaced from 12 to 15 inches in the drill row on medium land.

When sorghum is planted in hills, it should be checked, 3 feet by 3 feet, with 6 or 8 plants to the hill. Checking is more open than drilling,

hence can be more easily cultivated. It also permits cross cultivation, which is impossible in the drilled field.

Depth to Plant — Sorghum seed should not be planted more than an inch or an inch and a half deep except in the driest weather. When the seed is planted too shallow in dry weather it cannot get enough moisture to germinate well, and the plants are stunted at the outset.

The Amount of Seed to Plant — Enough seed should be planted the first time to make replanting unnecessary. When seed does not come up as well as was expected, some farmers go over the fields again and replant in the missing spaces. The plants which are planted late never catch up with the first planting, but lag behind making an uneven stand. At harvest time some of the sorghum is too mature to cut and some of it is not yet ready to be cut. The result is a loss of a good part of the crop. Always sow from 3 to 4 pounds of seed to the acre. This will insure a good stand without missing hills. If only a few hills are missing, it does not pay to patch up the field with late planting.

The Time to Plant — It is highly important that syrup-making should come at a time when there is least farm work to be done. Cane and sorghum will not keep after it has been cut, but begins to ferment after a few days, and must be attended to right away. In the districts suitable for sorghum growth, the slack time comes in August and the first of September. Hence, the sorghum should be planted as early as possible to bring the harvest time into these two months. After the ground has lost its winter chill and as soon as the danger from frost is past, the sorghum should be planted.

Cultivation — Cultivation should begin as soon as the plants appear and should be frequent and thorough. It must be shallow. Deep cultivation after the plants are six or eight inches high is injurious. It cuts off the feeding roots which run in large numbers just beneath the surface of the soil, and checks the growth of the plant until it can throw out a new supply. It will be readily seen that continuous deep cultivation will prevent any growth at all and eventually kill the plant.

In addition to the horse cultivator, the hoe should be used between the plants in the rows.

Sorghum should be cultivated after each rain. This forms a dirt mulch over the ground, and kills all weeds before they can do any harm. When the plants are two or three feet high they are generally able to take care of themselves. But if the weeds become very bad, one or two very shallow furrows may be run between the rows with a heel-sweep, and the weeds further killed with a hoe.

In wet weather "suckers" should be watched for and removed with a sharp knife as soon as they appear. They seldom make their appearance except on undrained soils, however, and if the site has been carefully selected, there is little danger from them.

Harvesting — Sorghum should be harvested and ground as soon after

the seed is well in the dough as possible, and before it becomes mature and hard. When sorghum commences to mature, it is well to make a trip to the field every day or so, and test the seed. When it changes from a soft doughy texture to brittleness, that is the time to cut.

After the sorghum has been cut, the seed heads from the best plants or rows should be cut off at once and dried for next year's planting. Before cutting, the leaves should be stripped either by hand or with a flattened stick. The leaves contain chemical substances which hinder the crystallization of cane sugar and injure the flavor of the cane syrup. They should never be ground up with the stalks.

The stalks should be ground a day or two after cutting as evaporation immediately takes place, and fermentation changes take place which spoil the sorghum. Where a large area of sorghum must be handled, dump carts should be used to haul to the mill, as they are more easily and quickly operated.

CHAPTER VII

SUGAR CANE

I. SOILS. II. FERTILIZERS. III. SEED-CANE—STORING. IV. SOIL PREPARATION.
V. PLANTING. VI. CULTIVATION. VII. HARVESTING.

Soils — Sugar cane is a gross feeder and requires a great quantity of water during its growing period. A yield of forty-five tons of cane to the acre will require over fifty-six inches of rainfall. Canes, therefore, should be planted only in regions of abundant rainfall and on soils well fitted for holding water. As cane occupies the same piece of ground two and often three years in succession and as there is no way of restoring the food elements while the cane is in the ground, it should be grown only on soil that is rich in humus and well supplied either naturally or artificially with plant-food elements. Cane is a great nitrogen consumer, and it should never be planted on land that has not the preceding year been sown to clover, cowpeas, velvet beans, or some other leguminous crop.

Fertilizers — Where no legumes have been grown, the fertilizer should consist of about equal parts of acid phosphate and cotton-seed meal. In case the cane does follow a leguminous crop, the fertilizer should consist of two parts of acid phosphate to one of cotton-seed meal. The crop does not respond to potash fertilizers, and they need not be applied.

The fertilizer should be applied to both plant and stubble cane in the spring after the stand is complete and the dirt ready to be thrown back to the cane rows. Seed cane should also have a light application of fertilizer at the time of planting, because the roots which are put out around each joint should be promptly fed to insure a vigorous start.

Seed Cane — Sugar cane does not grow from seed in this country, although it does in the countries farther south. Indeed, it rarely comes to seed even in our most southern states. For this reason sugar cane must be grown from sprouts, secured by cutting and planting the cane so that the roots and plants can spring from the joints.

Seed-cane should be allowed to grow as late in the fall as is possible without danger of frost. When cane is cut very long before frost, it sprouts and these sprouts always get killed during the winter, injuring the crop for the following year. The oldest stubble cane should be used for seed. If immature and poorly developed canes are planted, the stand is sure to be uneven. The poorer canes will have many immature eyes which will not germinate at all, and many more that will germinate slowly so that in the next year's crop there will be many blank spaces and small short-jointed canes. Great care should be taken not to put diseased

canes in the bed. This may injure the growing powers of the best canes, or cause the entire seed crop to rot.

Seed-canes should have well matured buds and joints of medium length. They should be free from all moulds and disease.

Storing Seed-Cane — When cane is to be planted in the spring it should be bedded through the winter. Bedding should be done after a rain where possible. The rows are cut in the fall and are promptly piled, shingle fashion, between the old rows of cane. These windrows are to be covered immediately by running furrows with a turn plow on either side, throwing the dirt on the cane, and covering it carefully with the hoe. Prompt covering with dirt keeps out the air, prevents drying out or freezing, and checks dry rot. The bed should be located on a slope when possible, and furrows turned to drain water away, for should the bed become flooded in winter and the water stand there even for a short time the canes would probably ferment and the buds be destroyed.

If stubble is to be bedded for seed, it should be dug up and bedded with the root attached. Stubble cane used for seed is called ratoon cane. Ratoons should be cut very low. If they are cut high, fermentation and decay set in and injure them severely. The best way to bed ratoons is to run a light furrow along one side of the cane, dig the ratoons out and place them upside down in this furrow, and then cover them with another light furrow. It is not a good plan, however, to use ratoons for more than two years in succession. The yield gradually runs down.

Soil Preparation — Soil intended for sugar cane should be prepared as long in advance of planting time as the previous crop will permit. The deeper the land can be plowed the better for the cane, because of its extensive root system and the length of time it occupies the field. Fields that have been in cultivation for a number of years will be benefited by subsoiling to a depth of 18 or 20 inches. This gives a large storage area for water, and sufficient moisture is the controlling element in the production of sugar cane. After the vegetable matter has been plowed under, the surface should be harrowed deeply and worked back into condition by pulverizing several times before planting. To conserve the moisture the soil should be cultivated at least once a week until the cane is planted.

Planting — Lay off the planting furrows 6 inches deep and 6 feet apart. Into these furrows spread a small amount of fertilizer to feed the roots when they first spring out from the joints. This insures a good start.

The roots of the sugar cane spring from the joints in the stem, or stalk. Each joint in the cane has a small bud or eye from which the stem springs after the roots have sprouted. Each of the buds is independent of the others and will grow into a separate plant while the stem between the joints decay. It is, therefore, unnecessary to cut the cane at all when planting and is often injurious, because the injury to the cane in cutting causes fermentation and decay. The stalks of cane are rarely straight,

and must be cut in two or more pieces to fit the furrow. They should be cut as little as possible, however, and when straight, should not be cut at all.

The canes should be laid in the furrows, lapping them a few inches at the ends. Then they should be covered with three or four inches of soil. If planted too deeply in mid-winter the eyes will be slow in sprouting, and will not make a good vigorous growth.

Where natural drainage is good, dry rot is the greatest destroyer of seed. If the weather is dry at planting, a heavy roller should follow the planting of the cane to bring moisture to it and to prevent this disease. In poorly drained fields wet rot will prove equally destructive. Under such conditions beds nine or ten feet wide should be thrown up and two rows planted in each bed.

Cultivation—After the cane is well up, the furrow may be filled in to the level. This places the roots well below the surface and helps to prevent the plant from blowing over. Canes that are planted very shallow will often blow over and tangle during heavy wind-storms. The canes then grow into all sorts of shapes, which makes harvesting and grinding difficult. At this time, just before throwing back the furrow, the bulk of the commercial fertilizer is applied. It is not wise to combine this with manure. While manure applied in the spring beneath the crop produces an enormous growth, the cane is given a peculiar salty flavor which injures it and lowers its value for syrup or sugar.

Cultivation should begin soon after the canes are planted, mainly to prevent the loss from evaporation that will occur during the spring months unless the surface soil is mulched. The first two or three cultivations should be done with a weeder or harrow, which may be run in any direction over the rows. After the canes are too high for this, the one or two-horse cultivator, set shallow should be used. This must be run following the rows. Cultivation should be shallow, as the feeding roots of the cane run just below the soil surface. Cultivation should be kept up just as long as it is possible to run the cultivator between the canes, and as often as necessary. During the early part of the season the cane suffers severely if moisture is not supplied it. In the dry season cultivation should be frequent to conserve the moisture. In the rainy season cultivation should be just as frequent to hold the weeds in check. Cane should be cultivated until the cultivator cannot be dragged through the patch.

Harvesting—The first operation in harvesting is stripping the canes. The leaves contain substances which hinder the process of crystallization in sugar-making and injure the flavor of the syrup. For this reason they must be removed before the canes go to the mill. As there is a large amount of work involved in handling a crop of sugar cane, this stripping should be done early so that there will be no delay when the grinding season begins. The dead leaves are removed by hand

from the standing stalks. This can be most easily done by two downward strokes with the back of a knife. A third stroke removes the top of the cane, and a fourth severs the cane at the bottom.

Where the season is long enough the dead leaves may be removed and the stalks left standing for a week or so. This exposes the stalks to the sunlight and hastens the ripening of the cane. It may then be topped and cut at the proper time. The longer the cane can stand without danger of frost, the better will be the quality of the syrup. Immature cane makes inferior syrup. It is, however, recommended to cut one immature joint to every eight mature joints, because the glucose contained in the immature joints prevents the too rapid crystallization of the juice in evaporation.

After the cane has been topped, it should be cut as low as possible and put into rows ready for hauling. In case of an approaching freeze it is well to cut all the canes at once and cover them up with the tops to protect them. A white frost does not injure sugar cane, but checks its growth and hastens maturity. A freeze, on the other hand, will kill the buds and injure them for seed, and may induce fermentation and loss for sugar making.

Sugar cane is an extremely heavy crop, and because of the crookedness of the canes, a very difficult crop to handle. Dump carts are the best for conveying cane because they are quick in action and involve no labor in unloading. An ordinary hay rack with side boards one foot high is also a good wagon for moving sugar cane.



CHAPTER VIII

COTTON

I. SOILS. II. PREPARATION OF SEED-BED—DEPTH TO PLOW—FERTILIZERS. III. PLANTING—TIME—METHODS—DEPTH. IV. CULTIVATION. V. PICKING. VI. GRADING AND MARKETING. VII. THE SELECTION OF SEED—THE LATE COTTON PLANT—THE EARLY COTTON PLANT. VIII. THE IMPROVEMENT OF COTTON—STRUCTURE OF FLOWER—CROSS FERTILIZING THE COTTON FLOWER.

Soils—Cotton does best on sandy loam. A rich sandy loam, with a clay subsoil will always raise a good crop of cotton if properly prepared. Next to the sandy loam a clay loam is best. Red clays indicate the presence of iron, and these soils are naturally richer than ordinary clay soils. Chocolate clay is good.

A sandy soil warms earlier in the spring than a clay, and is therefore preferable for the northern belt cotton. Sandy soils are also much more easily cultivated and a better seed-bed can be prepared.

Preparation of Seed-Bed—When oats or some similar grain crop precedes cotton, the soil should be plowed as soon as the crop has been harvested. The chief objection to this is that a heavy growth of weeds will spring up late in the summer, using up a large amount of moisture and making it necessary to re-till in the fall or winter. Where the land is apt to become foul the soil should remain without plowing until most of the weed seeds have germinated.

Soil which is not broken during the summer should be plowed in

the fall or winter. If the crop is preceded by corn or cotton, the stalks should be cut as soon as the harvest is over and the ground plowed as soon as possible. On heavy loam soils all plowing should be done before the first of January.

Light sandy soils, however, should not be left exposed to the winter winds. With them, early plowing is not of so much importance as the early plowing of heavier soils. But no matter what kind of soil the cotton is planted on it should be plowed early enough to secure a firm seed-bed.

Depth to Plow—Cotton soil should not be plowed more than 8 inches deep. Where plowing has always been shallow, the increase should not be made at one plowing, but the depth should be increased an inch with each successive cultivation until 6 or 8 inches are reached. Plowing should always be from 6 to 8 inches deep except on light or sandy soils. Spring plowing is a bad practice, because it is difficult to get the seed-bed into shape late in the season. But if spring plowing is resorted to, it should never be so deep as fall and winter plowing.

Fall plowing should not be followed by harrowing. This is particularly true for sticky clay upland soils found so often in the cotton belt. Such soils run together after harrowing, and become too compact. In the spring the fall or winter plowed land should be thoroughly disked as soon as the weeds begin to appear. When the spring is backward, the field should be disked again to destroy the second crop of weeds. This diskng puts the soil into good tilth and conserves the soil moisture.

Fertilizers—The best fertilizer for cotton is manure. The cotton stalks should be cut into short pieces and composted on the field with manure. This insures the rotting of the manure and returns organic matter to the soil. Fifteen to twenty tons of manure to the acre, composted with the stalks in this manner are sufficient for most soils. Clay loams, while usually containing sufficient nitrogen and potash, are often deficient in phosphorus. When this is the case the stalks and manure should be composted as before, but phosphorus in the form of rock phosphate should be added to the compost. The acids of the manure act upon the phosphate and render it more available. About three hundred pounds of phosphate rock should be added to a ton of manure in the compost.

When a commercial fertilizer is spread direct upon the land, the requirements are as follows:

80 to 120 pounds cotton seed meal per acre.

160 to 240 pounds of acid phosphate per acre.

On sandy soils a complete fertilizer must often be applied. This is supplied by adding:

80 to 120 pounds of cotton seed meal per acre.

40 to 60 pounds of kainit per acre.

160 to 240 pounds of acid phosphate per acre.

The farmer must of course study his soils and determine in just what proportions the cotton seed meal, kaimit, and phosphate should be mixed. Each field has its own requirements, and the fertilizer must be adjusted to each and every field.

Time of Planting—Planting should be done as soon as the soil becomes sufficiently warm for the seed to germinate readily. No definite time can be set for planting, it depends altogether upon the climatic conditions. It is usual to plant between the first of April and the middle of May.

Methods of Planting—There are two methods of planting, level seeding and bedding. On good soils there does not seem to be much difference in the yields. On sandy soils level seeding should be practised as a rule, as bedding, which consists in throwing two ridges together to form a low hill, tends to intensify the effects of drought. On the other hand, bedding should be practised on heavy, cold soils, as it affords better circulation of air through the soil, and prevents flooding in wet weather.

Cotton is usually drilled and afterward chopped to a stand. The thinning is usually done by hand with a hoe when the first true leaf appears. The width of the rows should be from $3\frac{1}{2}$ to 4 feet, and large varieties may be left 14 to 16 inches in the drill, leaving from one to two stalks, but no more. Small varieties may be left closer together.

Depth to Plant—Cotton seed should not be covered very deep, especially if planted early. It may be planted deeper later in the season when the ground is warm and there is not so much danger from heavy rains. When planted early the seed should barely be covered, but when planted late the seed should be put into moist soils and this means planting from 1 to $2\frac{1}{2}$ inches deep. Planting should never be deeper than $2\frac{1}{2}$ inches or else the young plants will not be able to reach the surface of the ground.

Half a bushel to the acre is the proper rate to plant cotton. More than this necessitates excessive thinning later on, and less will not bring the land to its full producing capacity. Slightly more than one-half bushel may be used on very good land, and slightly less must be used on poor land.

Cultivation—If a crust forms on the surface after the cotton is seeded, it should be broken up by light harrowing. The first cultivation should be given as soon as the plants are up, and if the field is inclined to be weedy, it should be cultivated before the plants are up. The plants are very small, and the first cultivation must be shallow to prevent covering them up. The first two or three cultivations should be as deep as can be made without throwing too much soil upon the plants, from 1 to 5 inches where possible. This brings the soil into good condition. As the plants

grow, cultivation must become more and more shallow to prevent injury to the feeding roots, until finally the surface soil is merely pulverized.

The early cultivations should be made frequently enough to keep the weeds in check until the cotton has leaves enough to shade the ground. This will probably mean one cultivation a week for the first three or four weeks. The later cultivations should be made after rains to hold the weeds in check, break up the crust, and prevent evaporation.

The one-row, six-shovel cultivator does better work than the four-shovel. After the cotton begins to set fruit, a two-horse cultivator will injure the plants by knocking off the bolls. A one-horse five-shovel cultivator should then be used on the crop. In dry seasons, when the purpose of cultivating is chiefly to conserve the soil moisture, it is effective to drag a one-horse "A" harrow between the rows.

Picking—Cotton growers divide their pickings into three divisions, known as crops. The first bolls to open are known as the bottom crop; the second, the middle crop; and the third, the top crop. The bottom and middle crops are choice staple, the top crop is frequently immature. The top crop should be ginned separately, as its immaturity lowers the value of the whole crop, if it is mixed with the other two.

Cotton that has been picked before the bolls are wide open, and cotton whose bolls do not open before frost, is sure to contain unripe fibers, which lower its market value.

Grading and Marketing—In grading cotton the grader pulls a sample between the thumb and fingers until there are no uneven fibers. In doing this he notes how much is pulled out, which indicates its unevenness. Then he measures the fibers with a rule. Cotton mill machinery must be set to a certain length of fiber. If the cotton is too short, a fuzzy looking yarn and great waste results. If long and short fibers are mixed, and the machine set for short, the long ones are broken, which makes weak yarn. Cotton fibers must be uniform in length to bring the best market price.

The price of the cotton also depends upon its length. The long fibered cotton, like the sea-island, is used in the best cotton cloth manufacture, and brings the highest price. The medium lengths bring only the average price per bale, while the shortest fibered cotton is not worth growing. The farmer should always strive to get long fibered cotton.

To bring the best market price for its variety the cotton must not be off color. It must be white, not tinged with pink, green, or yellow. Cotton that has tufts of various colored cotton in it is called "tinged." Cotton that is colored deeply through, is classed as "stained." Both conditions arise from immature bolls, juices from crushed seed, water, or sweated and mildewed cotton. Both conditions cause the cotton to grade low and bring a correspondingly low price.

Cotton should be free from leaves, bolls, husks, stalks, seed, sand,

and other impurities. Their presence makes re-picking necessary at the factory, and lowers the value. These can be reduced to a minimum by proper care in picking and handling. Cotton should be carefully picked, and brought in from the fields free from sand and trash. It should not be subjected to pressure until baling time, for pressure will crush the seeds and stain the cotton.

Ginning and baling are done at the same time at public gins and presses. The ginning of the lower and middle crops should always be separate from the top crop, so that the cotton may not grade low because of the immature top cotton. Bales vary greatly in size. The most common dimensions are 54 by 36 by 27 inches, with a density of 16½ pounds to the cubic foot. This does very well for ordinary inland traffic, but when cotton is shipped long distances or abroad, it should be subjected to still greater pressure by means of the compress. This changes the dimensions to 54 by 20 by 27 inches, with a density of 30 pounds per cubic foot. Cotton thus pressed can stand much traffic, and is in the most convenient form for handling.

The Selection of Seed—The single stalk method is the best for selecting cotton seed. There are always some stalks in the field which are larger and more vigorous than the others. Their bolls are larger, and mature earlier than the average plant. The plants are the most desirable in the field from every point of view. Such plants are particularly well adapted to the region, and are of good permanent stock that will reproduce itself from year to year and will improve with careful selection. The farmer should mark these stalks early in the season by tagging or tying a piece of cloth about the stem.

In selecting the seed, two things should always be borne in mind: the plant must be thrifty, and it must mature early. This early maturing is of the utmost importance in controlling the boll weevil. The first two crops, bottom and middle, must be obtained as early as possible to get the top crop in without encountering the weevil, but, as this crop is not of much value anyway, the farmer need not worry. If he can get plants early enough to insure the first two crops, the weevil cannot do much damage to his crop.

It is not enough that the plants come up and blossom early. They must fruit early and mature early. Late varieties of cotton bear the middle crop at just the right time for the weevils, and nothing can save it. The top crop may come after the weevils have gone, but the main part of the crop, the middle crop, is destroyed, and with it are destroyed all the profits.

The farmer should learn to know the early cotton plant at sight, for it is his only salvation from the boll weevil.

Figure 1 shows a late, or ordinary variety of cotton plant. The growth is open, and the joints between the leaves long. The stems

are slender and rather long. The bolls are borne high up on the plant and are some distance apart. The first fruit limbs are high from the ground. Such a plant may be recognized anywhere by its open appearance.

Figure 2 shows an early cotton plant. The general appearance is bunchy and thick set. The stems are thick. The joints between the



FIG. 1. A LATE COTTON PLANT

Long joints and first fruit limbs are high up from ground. Plants of this type or structure fruit late and fruit slowly, and are not adapted to boll weevil conditions.

leaves and bolls are very short. The first bearing stems spring close from the ground, and the bolls are bunched close around the low bearing stems. This gives a large first crop which is sure to be ahead of the weevils.

First, then, the farmer should select and mark the best of his early plants. Then he should pick and gin the cotton from these plants sepa-

rately, saving the seed, and measuring the cotton to see if it is up to standard.

The seed from these plants should be spread out on a clean table, and all the small, lop-sided and otherwise inferior seed removed by hand.



FIG. 2. AN EARLY COTTON PLANT

Short jointed and low fruit limbs. Plants of this structure fruit early, rapidly, and are well adapted to boll weevil conditions.

This seems like a great deal of trouble, but it will pay in the end. The seeds may be dampened and rolled in ashes. This makes it easier to remove the small seed.

Always select the lowest and earliest maturing bolls if they are well developed. If these are injured or inferior, select the best of the middle bolls, but never save the top bolls. The vitality of the plant has been exhausted by the two preceding crops, and therefore the seed will be low in vitality. Seed from the top bolls is likely to result in a poor stand of weak and diseased plants, and a poor grade of fiber.

Never select your seed at random from the gin. There is no knowing from what kind of plants it came. It is more than likely to be from late varieties and from the top crops. Selection from the field is the only intelligent way to get good seed.

Do not buy seed from other localities if you can possibly raise your own seed. It takes some time for cotton to become adapted to changed conditions, and while it is adapting itself the yields will be low. Many imported varieties linger along for a few years and then turn out to be total failures. Go out into the field and select your own seed from the best of your own plants. It pays royally in the end.

THE IMPROVEMENT OF COTTON

Cotton may easily be improved by the careful selection of seed and by proper cultivation. But this is a slow process, extending over three or four years at the best. The shortest and simplest way to improve cotton is to cross one variety with another. The large size of the flower, and the fact that cotton is naturally cross-fertilized enables us to do this with ease.

Structure of Flower — First let us examine the flower. There is a cup-shaped corolla of five large yellow petals, each backed by a leafy bract. From the center of these the pistil rises, a slender column with a flattened, club-like end, the stigma. This pistil is the female part of the flower, which, when pollen falls upon it, produces seeds. Springing from the base of the pistil are numerous slender stems, each bearing a little yellow bag at the end. These are the filaments, and the little bags contain pollen with which to fertilize the pistil. The filament with its pollen sack is called the stamen, and is the male part of the plant.

The cotton is to a certain extent self-fertilized, since the stamens are above the stigma, and the pollen falls down upon it. But bees, wasps, flies, and numerous other insects, in gathering honey and pollen, leave pollen from other flowers and other plants upon the stigmas which they touch. The result is a cross. Some valuable crosses have been obtained in this accidental way, but most of such crosses are at random, and result in mongrel varieties.

Now, man can transfer the pollen from one plant to another and produce excellent results. All that is necessary is good judgment in selecting the plants to cross and a little care in transferring the pollen.

Cross-Fertilizing the Cotton Flower — First, the plants selected should be strong and vigorous and possess as nearly as possible the

character of the ideal plant you wish to produce. If you want an early variety that will have large yields, select the best early plant you can find in your field and cross it with the one having the heaviest yield. If you want a long staple variety on a small bush or on an upland plant, select the plants having the best staple and the best upland characteristics and cross them. This illustrates the fundamental rules in selection. Get the better of the two varieties you want to combine and cross them. If you can select from strains which have been improved from seed selection as well, so much the better. That makes successful crossing more certain.

Second, remove all flowers or buds from the mother plant except the few best flowers which you save to cross. Then, just before the flower opens, cut away the yellow petals with a pair of scissors and remove the stamens with their little pollen sacks in the same way, being careful not to injure the pistil. This prevents self-pollinization, which would render the crossing ineffective, or only partly effective. Half a dozen flowers are enough to cross on one plant. If buds form during the operation they should be cut away so that their pollen may not interfere. The plant should then be covered with a piece of mosquito netting to keep out insects which might carry pollen to the flowers.

Third, gather the flowers from which you expect pollen and put them in a shady place free from insects, where they will open in a few hours. As soon as the pollen sacks burst, clip the yellow petals off for convenience, and apply the pollen by brushing it gently over the pistil of the mother plant until it is thoroughly covered with it. Continue this until all the flowers have been treated, or pollinated. Then replace the mosquito netting for a few days until the field is out of flower. A convenient method of covering and protecting from insects is to tie a small paper sack over the flower before and after the cross-pollinization.

The seeds resulting from the crossing should be carefully saved by hand and planted next year, marking them in some manner, and observing the same rules as have been laid down for selection and cultivation.

Careful selection for early varieties, a careful crossing for long staple varieties, careful preparation of the seed-bed, and cultivation for record yields will make cotton a success in spite of the boll weevil.

CHAPTER IX

CLOVER

I. SOIL. II. PREPARATION OF SEED-BED—INOCULATION. III. PLANTING—DEPTH—TIME—AMOUNT OF SEED TO SOW. IV. TESTING CLOVER SEED. V. CUTTING—FOR HAY—FOR SEED. VI. HARVESTING SEED. VII. STORING CLOVER. VIII. ROTATIONS.

The Soil—Clover can grow on almost any kind of soil, from light sand to heavy clay. Many varieties grow wild on abandoned fields and pastures, reseeding themselves each year, and requiring no attention whatever. However, clover cannot make its best growth on heavy, acid soils. Heavy soils exclude the air, and the nitrogen-fixing bacteria which make their home in the root-nodules of the clover plant are forced to slow down their work for lack of free nitrogen. They cannot use any other form of nitrogen, and the clover plant cannot get enough for its needs from the soil, and so growth takes place very slowly. A porous, open soil, in which the air can circulate freely is the first requisite for a good clover crop.

Acidity also checks the growth of clover. The nitrogen-fixing bacteria, like most bacteria, are inhibited in their growth by acids. That is, the acid poisons them, and they cannot grow and develop normally. Even the slight amount of acid present in an acid soil checks their growth, and when they cannot store up nitrogen for the clover, the clover ceases to grow well. So the second requisite for a good clover crop is a soil that is not acid:

Soil that is not well-drained fills up with water during the wet season. This water of course drives out the air, stiffens the soil, and permits acids to accumulate. Thus the third requisite of good clover land is that it be well-drained. An ideal clover soil is a well-drained, rich and porous clay loam, covering a limestone formation.

Preparation of Seed-Bed—Clover requires very little land preparation on light soils. It does not require as much manure as the grass crops, because it is itself a gatherer of nitrogen and a builder of soil fertility. On heavy soils, deep plowing should be practiced, as it aids in breaking up the soil and in establishing a good supply of air. Wet and marshy soils should always be well-drained with ditches or tile before attempting to grow clover.

Inoculation—One of the important things in preparing the seed-bed is proper inoculation. Clover simply will not make a large crop

if deprived of its tenant bacteria. It has become so accustomed to having their store of nitrogen to fall back on in hard times, that it cannot do well without it. It will grow without inoculation on very rich soils, where no difficulty is encountered in finding nitrogen. As the chief value of clover, or any leguminous crop, for that matter, lies in the nitrogen which it takes from the air and stores in the soil, we consider a stand of clover which fails to develop nodules on its roots as not fulfilling its true purpose.

Soils may be naturally inoculated. Wild varieties of clover may have trespassed into them from the roadside, and left their bacteria in the field ready for work. This may be found out by growing clover there and noting the stand. If the stand is very poor, and no nodules develop on the roots of the plants the soil needs inoculation.

One successful way to inoculate a field is to scatter earth from some good clover field over it. The best way to inoculate is to scatter from 200 to 500 pounds of earth broadcast to the acre just before planting, or to mix the seed with the earth and apply with broadcaster of some sort. Where the soil needs to be carried some distance, or the cost of labor is great, the amount of soil may be reduced to 200 or 300 pounds, and only one corner of the field inoculated. If a good catch is obtained, the earth from this corner will be enough to inoculate the entire field the next year. An application of well rotted manure will aid in securing a good first year's stand.

Fields will become infected with the proper bacteria without artificial inoculation, if clover is grown on the same field through a succession of years. The red clovers of the north very seldom if ever need artificial inoculation. The same is true of alsike and white clovers.

Sowing—Clover may be sown with wheat, rye, oats, or on corn stubble with equal success. It may be sown either with or without a nurse crop. Winter wheat and rye are good crops to seed down with on clays and loams. These grains should be planted in the fall as usual, and the clover sown very early in the spring, on a frosty morning before the ground has thawed enough to make walking difficult. The seed may also be sown after the ground has dried up sufficiently so that it may be harrowed in with a spike harrow. If care is taken to set the teeth of the harrow at a sufficient slant, little damage will be done to the grain.

When clover is sown with spring grain, the seed should be broadcasted in front of the seeder or drill with a clover or grass-seeding attachment. For small fields it may be sown with a barrow or some other hand seeder and covered lightly with the harrow afterwards.

On light sandy soils it is better to sow the clover without a nurse crop and cover more deeply than when a nurse crop is used.

Depth to Plant—When planted with a nurse crop, clover should be put in half an inch deep. When planted by itself, clover should

always be planted deeper. Three-quarters of an inch to one inch is the proper depth to plant.

Time to Plant—In the northern tier of states, clover is generally sown in the spring, as early as convenient, while the ground is yet moist. Farther south, where the clover is not liable to be winter killed, there are two general times for sowing. The clover may be sown on prepared ground in April or May, and cut for hay before fall, or it may be sown about the last of August, and pastured in the fall. The latter course is pursued where early crops like peas or potatoes have been raised, and the farmer does not wish his land to lie fallow through the fall and winter. In the extreme south burr clover is used almost altogether as a catch crop, being broadcasted over the field in August or September. The reason for this is the leaching of southern soils if left fallow through the winter. A crop of burr clover will grow all winter in Alabama or Georgia, preventing leaching, covering the ground with a growth of foliage and roots that prevent gulying, and adding to the fertility of the soil by bringing in a supply of nitrogen.

Amount of Seed to Sow—On new land, or land which has not grown clover to any extent, use 12 pounds of high testing seed per acre for medium red, mammoth, alsike, or sweet clover. Burr clover should be used at the rate of from 1 to 2 bushels per acre.

Testing Clover Seed—Clover seed should always be tested for germination. It is not unusual to find seed on the market which tests only from 25 to 30 per cent germination. It is difficult enough to get a good stand of clover anyway, without adding the handicap of dead seed. The method discussed in Chapter VII, Book I, serves very well for making this test. As a rule no clover seed should be planted which does not test at least 85 per cent germination power. It involves too much loss from missing plants.

Cutting—Medium red clover and sweet clover furnish two crops a season, but in order to secure seed, the first crop should be cut early, about the middle of June. If the crop is heavy at the first cutting it should be made into hay, but if it is light, and the soil is not in fertile condition, it is best to clip it when about six inches high and let the clippings rot on the ground. Sometimes, when the crop is too heavy, it is advisable to check the growth early in the season by pasturing. Care should be taken not to turn stock into a rank growth of clover while it is wet with dew or rain because of the danger of bloat.

If clover is cut for hay, it should be done when the heads begin to turn brown. If delayed too long the stems become woody, and the leaves, containing most of the protein which makes clover valuable for hay, will drop in curing. It is always well to visit the field at this time and to decide whether the crop is worth saving for seed. With a good stand of clover there should be about twenty-five good seeds to the head to make it worth while as seed. If this standard is not

reached, the clover should be cut at once with an ordinary mower, and put up when partially dry in small cocks to cure.

If the farmer decides that the clover is good enough for seed, he should wait until most of the seed heads are ripe, but the seed not all colored. The clover should then be cut with a mower having a windrow or bunching attachment, so that the crop need not receive excessive handling. The seed heads are brittle when partially dried, and care must be taken not to break them off. Seed clover should be dried before storing. It should not be allowed to stay in the field until the straw is rotted, as this injures the seed by excessive weathering and makes the straw worthless for feed.

Harvesting Seed — If only enough seed is desired to re-seed a field,

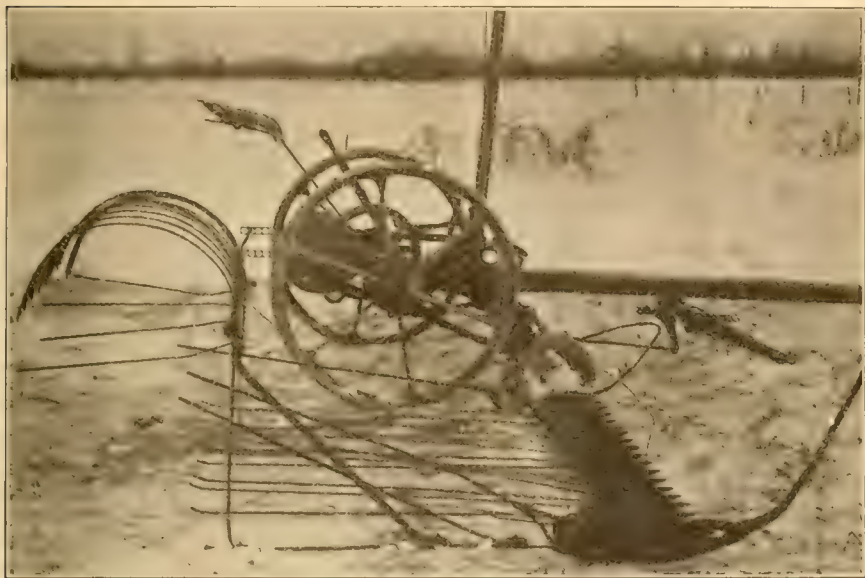

Fig. 1.—Bunching Attachment with Rake Raised.

Courtesy of the Wisconsin Experiment Station.

enough can be obtained by using the flail after the plants are quite dry. But where seed is raised for sale such primitive methods will not do. Clover seed should be threshed out the same as grain, in a specially equipped machine. Many threshers now carry special concaves and attachments for threshing clover, but special clover-seed hullers, with a re-cleaning attachment are much to be preferred to the hulling attachments found on threshers. They do their work more thoroughly.

Storing Clover — Clover hay should never be stored in open stacks, unless they can be covered with a roof or tarpaulin. Clover spoils very quickly when it becomes water soaked, and much of the hay in an open

stack is sure to be lost even under the most favorable conditions. Always store clover hay in the mow of a barn where it is sure to remain dry.

Clover seed should be bagged direct from the thresher, and stored in a safe place.

Rotation — Clover has two functions in rotation; to store nitrogen in the soil, and to act as a forage crop. On heavy and moderately heavy soils, the following rotation is good:

First year — Alsike clover, to be cut for seed.

Second year — Mixed hay.

Third year — Peas.

Fourth year — Small grains seeded to clover.

This rotation is good for new farms in a clay country. It is well adapted for combination with sheep raising.

Another rotation, good for combination with dairy farming, is:

First year — Medium red clover, first cutting for hay and second for seed.

Second year — Mixed hay.

Third year — Corn or any cultivated crops.

Fourth year — Grain seeded to clover and grass mixture.

Having one year in cultivated crops holds the weeds in check.

For light soils, the rotations are somewhat different:

First year — Clover sown alone, to be clipped in the fall or pastured.

Second year — Clover cut for seed or hay, second crop plowed under.

Repeat.

This is simply a method of bringing a poor soil up to standard. It requires more land under cultivation, as nothing but light pasturage can be expected the first year of rotation.

Another rotation is:

First year — Clover sown alone and pastured in fall.

Second year — Clover, to be cut for seed.

Third year — Corn for silage, or potatoes.

CHAPTER X.

ALFALFA

I. SEED SELECTION—GERMINATION. II. SELECTION OF THE FIELD. III. CORRECTING ACID SOILS. IV. INOCULATION. V. THE SEED-BED. VI. PLANTING—DEPTH TO PLANT—METHOD OF PLANTING—TIME OF PLANTING. VII. FALLOWING. VIII. CULTIVATION. IX. STORAGE.

Seed Selection—Alfalfa seed is somewhat like clover seed, only a little larger and perhaps not so plump. It should be yellow or olive green in color. It should always be carefully screened to remove weed seeds.



Fig. 1.—Results From Alfalfa Feeding.

drained land should be selected. A rich clay loam on top of gravel or

Germination—Germination tests should be made with alfalfa seed by the method described in Chapter VII, Book I. Care should be taken to moisten the blotter paper as often as needed, but not to flood the small seeds. The test should be completed on about the fifth day, and if more than 15 per cent of the seeds have failed to germinate, the alfalfa will not do for seed. This gives a minimum germination of 85 per cent.

Selection of the Field—In introducing alfalfa on a farm some care should be taken as to its location. In general any soil that will grow clover or corn is suited to alfalfa, but on its first trials, high, well-

limestone is ideal. Bottom lands that are subject to overflow and level lands where the water can stand and form ice in freezing weather should be avoided, for alfalfa plants suffocate and die within a few hours when submerged. Ice smothers the plants at once. Land that has a water table only two or three feet from the ground surface should also be avoided, as it is essential that the alfalfa roots penetrate deeply into the soil.

Correcting Acid Soils for Alfalfa—The natural home of the alfalfa plant is on limestone soils. No matter how favorable other conditions



Fig. 2.—Roots of Alfalfa One Year Old.

Courtesy of the Wisconsin Experiment Station.

may be, if the soil is acid and sour, alfalfa cannot be grown on it successfully.

Acid land can sometimes be determined by certain plants which thrive on it, as sheep sorrel and mare's-tail. It can always be determined by means of litmus paper, which turns from blue to red in contact with acid. Secure some slips of blue litmus paper from the druggist. Do not handle it much, for the perspiration from your hands may show an acid reaction. Be sure that your knife blade is clean before you start out. Stick the blade of your knife into the soil, and drop a piece of the litmus paper down in the slit, pressing the earth around it firmly.

Mark the place with a twig or stick, and leave it there for ten minutes while you make some more tests. At the end of ten minutes return to your first paper and pull it out. If it is blue or purple in color well and good. But if it is red, the soil is acid and must be treated before alfalfa can be grown on it.

Heavy applications of manure generally insure a good catch of alfalfa. But on acid soils the acid must be counteracted or neutralized, by the application of dry marl or crushed limestone, at the rate of one to four tons to the acre.

Inoculation — Alfalfa, being a legume, requires the aid of certain bacteria for successful growth. These bacteria enter the roots from the soil, and establish factories in the nodules where they store up nitrogen for the plant. They pay rent to the plant in nitrogen for the use of

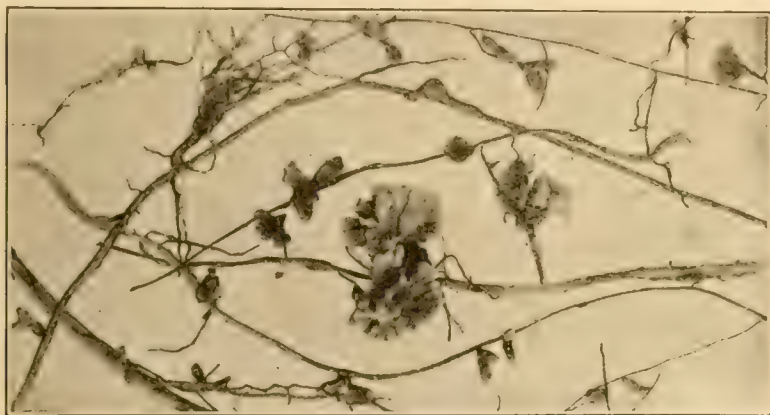

Fig. 3.—Alfalfa roots showing nodules. The bacteria in these gather about 200 pounds of nitrogen per acre from the air in one season. At 15 cents per pound, the value of this nitrogen would be \$30. One hundred and fifteen pounds of this nitrogen is removed with the hay crop, and 85 pounds remain in the roots.

Courtesy of the Nebraska Experiment Station.

its roots to live in. They get their nitrogen from the air and not from the soil, so that any plant which harbors them is largely independent of the nitrogen in the soil and can live perfectly well with only a limited supply.

Methods of Introducing Bacteria — Soil taken to a depth of six inches to a foot from an alfalfa or sweet clover field where the plants are known to be inoculated may be used at the rate of about two to five hundred pounds per acre. It is well to avoid exposing the soil to the sunlight for any considerable length of time. Part of this soil may be sifted and from ten to twenty pounds mixed thoroughly with the seed for each acre. The seed should be slightly moistened before mixing and the mixture shoveled over frequently until dry enough to sow. The fine soil particles and the bacteria cling to the seeds and are ready to begin work as soon as the plants start growth. The remaining soil

may be scattered broadcast at seeding-time and harrowed in immediately. Care must be exercised to secure the soil from clean fields so that the roots and seeds of noxious weeds and alfalfa diseases will not be introduced. In order to secure a thorough inoculation of the alfalfa plants the first year, it is important that the soil containing the bacteria be mixed thoroughly with the soil in the field. This can be done best with the disk or harrow just before the seed is sown. Feeding alfalfa hay and spreading the manure on the field to be sown probably introduces some bacteria.

By sowing alfalfa on a field and leaving it for several years, or if a poor stand is secured, by plowing it up and sowing alfalfa again, a larger percentage of the plants may be found inoculated each succeeding season. Some bacteria are probably introduced on the alfalfa seed. In attempting to secure gradual inoculation, a small amount of alfalfa seed may be sown with the grain or in the corn at the last cultivation each year for several years previous to seeding the field to alfalfa. The uncertainty of securing thorough inoculation by this method makes it the least desirable to follow.

Pure cultures of bacteria for use in treating seed are furnished without charge by the United States Department of Agriculture, Washington, D. C., with directions for use. Soil from sweet clover patches along the roadside may be used with fair success, but the inoculation of the plants usually will not be so general the first season as if soil is used from a well-inoculated alfalfa field.

The large roots and crowns of the alfalfa plants make a substantial addition to the organic content of the soil. The roots and crowns decay quickly, leaving the soil mellow and highly productive.

Introduction of Bacteria Advisable—After the bacteria are present in a soil, they will continue there for several years, even though the field is used for other crops. When alfalfa is grown more widely and is worked into the rotations, the introduction of bacteria will not be necessary except on new fields. Until then it is not good business practice to sow alfalfa without being sure that the proper bacteria are there. Because the alfalfa plants in one field in a community are found to be inoculated without the artificial introduction of bacteria, it does not necessarily follow that the same result may be expected on nearby fields. By sowing a square rod of land to alfalfa this spring and introducing the proper bacteria, sufficient soil will be right at hand next year to introduce the bacteria into a 50-acre field.

The Seed-Bed—No plant responds more readily to good treatment than alfalfa. The field should be fall plowed 8 to 10 inches deep so as to have a deep, mellow seed-bed. In the early spring a disk harrow should be run over the land, and it should be followed by a fine-tooth harrow at weekly intervals until about June 1st so that the weeds may sprout and be killed. When weeds are troublesome continue until July.



Courtesy of Rhode Island Experiment Station.

FIG. 3.—Alfalfa. Results of Inoculation



Fig. 4.—Unmuculated Alfalfa.

Courtesy of Rhode Island Experiment Station.

Sowing — The alfalfa should then be seeded without a nurse crop, using from 15 to 20 pounds of seed to the acre. It may be sown with a hand-seeder, or with a grass-seeder attachment. When sown by hand or broadcasted with a seeder attachment, a slant-tooth harrow should be run over the field to cover it lightly.

Depth to Plant — Alfalfa should be sown from three-fourths of an inch to an inch deep, depending upon the condition of the soil. It should never be sown more than an inch deep, however, as the young plants will never reach the surface if planted too deeply.

Seeding With a Nurse Crop — The seeding with a nurse crop can be done in one operation, provided a drill or seeder with a grass-seeder attachment is used. The alfalfa seed is broadcasted by the attachment and is covered as before with a spike-tooth harrow.

Time of Planting — The time of seeding is governed by the best time for seeding the nurse crop used. This is sown thin, using only about half as much seed as the cereal would require by itself. On rich soils barley is one of the best nurse crops for alfalfa; spring and winter wheat are also good.

Fallowing — Where land is very weedy, it is advisable to summer fallow and sow to alfalfa from the middle of July to the first week in August. The moisture conserved in the soil by fallowing gives it a good start. It should reach a height of at least six inches before winter, otherwise it will winter-kill. Often where early peas or potatoes have been harvested, the land can be properly fitted and put into alfalfa. When sown with a nurse crop, if the season is extremely dry, it is best to cut the nurse crop for hay, and give the alfalfa a chance to grow. Under ordinary conditions, however, the nurse crop should be allowed to ripen.

Cultivation — The alfalfa crop is often benefited by a light coating of well rotted manure. This should be put on during a dry spell or after the ground is frozen in the fall, so as not to injure the plants by driving over them. An old alfalfa field is benefited by harrowing it in the spring.

Harvesting — Alfalfa should be cut when in the advanced bud stage, and when only a few of the plants are in blossom. Sometimes the alfalfa will come into bud and then hesitate to blossom. Sprouts will immediately start at the base of the plants, and if these appear the crop should be cut at once.

Cut when the weather is fair; rake and put it into small cocks in the afternoon of the same day. The cocks should not be left standing in the field more than two or three days during rainy weather. The alfalfa will heat and smother the plants under the cocks. In favorable weather, however, alfalfa cures much the same as heavy growths of clover.

Like clover, alfalfa should receive the least possible handling, because

the leaves, which are richest in protein, drop off readily when dried. A much better grade of hay will be secured if the alfalfa is cured under hay caps rather than in open cocks or windrows.

Storage— Alfalfa should never be stored in open stacks. It spoils readily when wet, and if stored outside, it should be covered with a tarpaulin or an outside roof. The best place for storage is in the mow of a barn.

Rotation— Except where alfalfa has become thoroughly established upon the farm, no attempt should be made to fit it into a rotation. On account of the special care given to the selection and fitting of a field for alfalfa, it is wise to leave the alfalfa on the field as long as it produces well. When the land becomes weedy, or the field becomes patchy it is well to plant corn or some inter-tilled crop. This two-plant rotation is the most common for alfalfa, three years in alfalfa and then one year in corn. When alfalfa is used as a soil builder in a more complicated rotation, it is used as a substitute for clover, and is put to pasture before corn.

CHAPTER XI

POTATOES

I. SOIL. II. ROTATION. III. MANURING. IV. COMMERCIAL FERTILIZERS. V. FERTILIZER TESTS. VI. PREPARATION OF THE SEED-BED. VII. PLANTING—TIME—DEPTH—AMOUNT OF SEED. VIII. CULTIVATION. IX. HARVESTING. X. STORAGE. XI. THE SELECTION OF SEED POTATOES.

The Soil — The ideal potato soil is a sandy loam underlaid by a more or less clayey subsoil. Very sandy soils are excellent for potatoes as long as their fertility lasts, but they soon run down and require commercial fertilizers or heavy applications of barnyard manure. A sandy or gravelly subsoil is undesirable because it fails to supply water to the potato in dry seasons. A heavy soil is not mellow enough, and the potatoes cannot grow evenly or large in it. A sandy loam permits the potato to spread to its full size, and a clay subsoil under it will hold sufficient water in the soil at all times.

Potatoes should never be grown on lowlands or where the drainage is poor. When the potato is submerged in water for part of the season, it invariably is attacked by rots. The result is usually a complete loss of the crop.

The potato should always be put on good soil in regard to both fertility and drainage, since it is fully as exacting in its demands as any other crop.

Rotations — The success of the potato is largely dependent upon the crop preceding it in rotation. Clover, cowpeas, or some legume should precede potatoes when the soil needs organic matter. The legume is plowed under and leaves the soil in the best possible condition. Rye is sometimes sown in the fall and plowed under to improve heavy soils. Corn after sod frequently precedes potatoes, and this is generally regarded as a good rotation.

It is much easier to control underground diseases such as scab and brown rot if a rather long rotation is used. One or two years at the most is as long as a field should be devoted to continuous potato culture. It taxes the soil fertility too heavily and involves considerable injury from fungous diseases.

A good rotation is:

First year — Winter wheat, in which clover is seeded in the spring.

Second year — Clover, plowed under in the fall.

Third year — Potatoes.

Another good rotation is:

First two years — Corn and small grain.

Second two years — Hay.

Fifth year — Potatoes.

In this way potatoes are grown only once in five years, and the scabs and rots are more effectively controlled.

A general rule to follow in potato rotation is that grain should be followed by a legume, and the legume in turn by potatoes.

Manuring — From 8 to 10 tons of manure should be applied to the acre. Fresh manure may be applied after the first crop of hay without much danger to the next year's potato crop. When potatoes follow clover the manure should be applied in the fall. Fresh manure should never be applied directly to the potato crop. If it is applied in the spring make sure that it is well rotted.

Barnyard manure is the best to apply, because it furnishes nitrogen, phosphorus, and potash and at the same time leaves the soil in better physical condition. Horse manure is favorable to scab and should be avoided for potatoes.

Commercial Fertilizers — On sandy or somewhat run down soils, commercial fertilizers should be used to get quick results. It must be remembered that nitrogen can be readily secured through the use of legumes, hence it does not usually pay in the end to buy nitrogenous fertilizers. Numerous special potato fertilizers are on the market, their peculiarity consisting in a higher percentage of potash than is contained in the ordinary fertilizers. The reader is advised not to buy them. It is cheaper to buy the fertilizing ingredients direct from the factory and to mix one's own fertilizers at home. All that is necessary is a screen and a hoe and a little common sense as to the needs of the field. In buying direct one can save filling and mixing charges, and secure better quality. Cheap fertilizers do not pay. The chemicals are of poor quality, the filler is often of the poorest dirt, and the efficiency is low.

High grade fertilizers cost money, but they produce results. Low grade fertilizers are cheap and do not produce results. The farmer who buys his own super-phosphate from the factory gets what he orders. His material is of the highest quality. He does not pay freight on tons of worthless sand used as a filler. He can mix his fertilizers to suit the needs of his individual fields. He saves money.

Fertilizer Tests — If the farmer mixes his own fertilizer, as he should, he must lay out a number of test plats to see what amounts are best for his lands. Eight rows half a mile long, or sixteen rows eighty rods long constitute a plat. The first plat should not be nearer than twelve rows to the fence. Each plat is numbered and marked with a stake. Plat No. 1 is left untreated, and is called a check. No. 2 should have a treatment of sulphate of potash at the rate of 100 pounds per

acre. No. 3 should be treated with 11 or 16% acid phosphate at the rate of 300 pounds per acre. No. 4 is a check plot again.

In the fall the potatoes from every plot should be dug and weighed separately, and the results carefully recorded. The yield per acre should then be computed. When the condition of the soil and the rainfall and the amount of manure applied have been considered, the yields thus obtained show pretty accurately the amount and kind of fertilizer to use on a given field. The farmer can do his buying and mixing accordingly.

Preparation of the Seed-Bed—Plowing can scarcely be too deep provided that too much subsoil is not brought to the surface at once.



Fig. 1.—Planting Potatoes.

The best method is to plow about 5 inches deep when the land is first broken, increasing the depth a couple of inches with each successive potato crop until a depth of 12 inches has been obtained. Though the tubers usually lie about 6 inches from the surface, the roots go down much deeper, from 12 to 36 inches. Fall plowing is usually to be preferred. But in a mild climate fall plowing permits leaching, especially on light land. When a field is badly infested with insects, fall plowing becomes necessary to hold them in check. Sod land should be double-disked and then gone over twice with the disk harrow. Stubble land often needs only a couple of diskings.

Planting—The rows should be placed as close together as is prac-

licable without interfering with horse cultivation. The distance depends upon the kind of a cultivator that is used. For the ordinary six-shovel riding corn cultivator the rows should be three and a half feet apart. For a walking cultivator or a narrow-gauge riding cultivator a distance of three feet between the rows is sufficient.

Hill planting is best adapted to soils lacking in fertility, as it gives each hill plenty of room. It is well adapted to weedy land as it permits cross cultivation. Hill planting should always be done in checks, with the hills thirty inches apart one way, by thirty-six inches apart the other.

The distance between the hills in a row varies with the variety of potato and the richness of the soil. On medium soil early varieties should be planted from twelve to sixteen inches apart. Late varieties require from seventeen to twenty inches. Of course the distance may be shortened on rich soil, and must be lengthened on poor soil.

Planting should always be done with a planter, as it saves considerable labor, and enables the farmer to take advantage of a brief period of favorable weather at planting time.

One of the best tools to use in potato planting is the wing-shovel plow. There should always be a steadying gauge wheel near the front end of the beam. The advantage of such a plow is that it makes a furrow which is narrow at the bottom, and the seed pieces can be planted in a straight row without much difficulty.

Time to Plant—Potatoes should be planted at such a date as to bring the growing stage of the tubers at a time when there is a sufficient amount of moisture to supply them. The month in which dry weather is most certain varies with the locality, and each potato grower must time his crop so as to be least affected by the prevailing drought.

When potatoes are grown for the early market they should be planted as early as possible without subjecting the young plants to severe cold. Late varieties should be planted early enough to avoid frost. Where the season is long, the crop that is to be stored over winter should be planted late.

Potatoes may be planted from the middle of April to the first of June through the middle and northern states with good results.

Depth to Plant—The roots of a young potato plant do not grow directly from the seed piece, but from the underground joints or nodes of the main stem. From these nodes also grow the short stems which bear the tubers. Hence the pieces should be placed deep enough in the soil to permit several of these joints forming below the surface. This affords room for an ample supply of roots and tuber stems.

Early varieties of potatoes should not be planted as deep as the late ones. On light soils early varieties may be planted 3 or 4 inches deep, and late varieties 4 or 5 inches deep. On heavy soils the depth should be about one inch less in each case.

When the soil is cold and wet, the potatoes should be planted even more shallow.

Amount of Seed to Plant — The amount of seed to plant varies from 10 to 20 bushels to the acre according to the size of the seed pieces. The following table gives the amount of seed to plant very concisely:

Bushels of Seed Per Acre. Sizes of Seed Pieces and Distance Apart. Rows Three Feet Apart

Weight	Inches between hills	
	15	13
Oz.	Bu.	Bu.
.75	9	7.5
1.00	12	10.0
1.25	15	12.5
1.50	18	15.0
2.00	24	20.0

Cutting Seed — The cut seed should be as uniform in size and as blocky in shape as possible. Long thin pieces plant unevenly and are



Fig. 2.—Hopper for cutting potatoes. Note the stationary knife against which the potatoes are cut.

Courtesy of the Minnesota Experiment Station

likely to rot in the ground. Cutting machines save some time, but they usually cut too many small worthless pieces, and do not cut uniformly. The best way is to cut by hand.

The quickest way to cut by hand is with the stationary knife. A bench is made some two feet high by twelve inches wide, and braced, with an opening in one end just large enough to receive the blade of a thin, sharp, case knife. A basket of uncut potatoes at one side, and a basket into which the cut potatoes may be dropped, complete the equipment. Cotton flannel gloves may be worn to protect the hands. The potatoes are halved or quartered lengthwise, and are then cut cross-

wise as many times as may be necessary to get pieces of the desired shape and size.

Another convenient bit of apparatus is the hopper, shown in Fig. 2. The potatoes roll out through the hopper as fast as they are cut. The knife can be plainly seen fastened upright before the mouth of the hopper.

Where many acres are to be planted, it is well to begin cutting several days early. The cut pieces must evaporate a little, or moulds and rot will readily attack them on the moist surface. On the other hand, they must not be allowed to evaporate too much or they will dry up. As fast as the tubers are cut they should be placed in sacks, not more than half a bushel in a sack, and set on the floor in a cool potato cellar, leaving a space around each sack for the air to circulate.

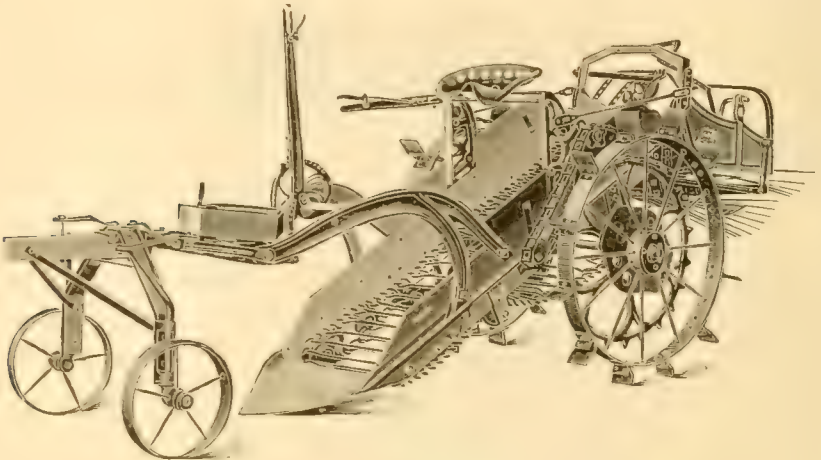

Fig. 3.—Potato Digger with Agitating Rear Rack and Vine Separator.

Never spread them out in the sun to dry. Never crowd the bags together or pile them on top of each other. Never place them where the ventilation is poor. Always keep them cool and the moisture normal. Good seed potatoes, carefully cut and handled, will keep ten days.

Cultivation — Soon after planting and again just as the young plants are beginning to show above ground, the field should be harrowed. Some injury may be done to the young plants after they are up, but it is absolutely essential that the weeds be held in check at this time. If the teeth of the harrow are tilted backward, the danger to the potato plants is minimized. The first few cultivations should be deep, because it is the last chance for deep thorough loosening of the soil. After the first week of growth, deep cultivation tears the roots and injures the plants.

Potatoes should be cultivated once a week for six weeks after they

are up to form a dry mulch and conserve the moisture. Cultivation should not be more than two or three inches deep. Occasionally new crops of weeds spring up after heavy rains. These may be destroyed by removing the two inside shovels from the cultivator, using only two on each side of the row instead of three. A weeder can be used to good advantage until the plants are 10 to 12 inches high. It has long flexible teeth, and cultivates several rows at a time. Besides destroying the weeds, it leaves the soil finely pulverized, and does not injure the root systems.

Flat or nearly flat cultivation should be practised, as hilling breaks many of the feeding roots and intensifies the injurious effects of dry weather, making it more difficult for the plants to obtain water. Only in wet soils should hilling be practised at all.

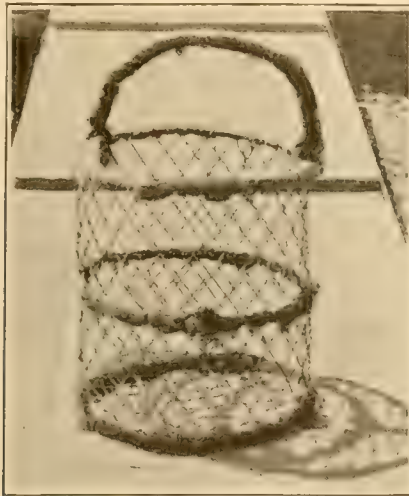

Fig. 4.—Reinforced and wrapped wire basket. Holds a liberal half-bushel.

Courtesy of the Minnesota Experiment Station.

Harvesting—Digging potatoes by hand with a six-tined fork is slow and laborious. Digging with an ordinary plow and raking them out with potato hooks is wasteful and injurious to the potatoes. The best method, where large areas are to be handled, is to buy a regular potato digger of the shaker type.

This gets the potatoes out in good shape, and separates them from dirt and vines. Care must be taken not to purchase a digger which has a basket attachment. These work only on light soils, free from weeds, and even then there is considerable waste.

The potato digger drops the potatoes as fast as it digs them and these must be picked up by hand. Secure a couple of wire baskets like that shown in Fig. 4. Each holds a good half bushel, and should

be wound with rags to prevent injury to the pickers. Set two men to follow the digger, filling these baskets as they go. Ten or fifteen bushel potato sacks can be strapped around the waists of the two pickers and carried easily. When the baskets are both full, one of the men jerks a sack from the strap and both empty their baskets into it. The sack is thus filled and is ready to be hauled to the cellar. The two men start picking up again and the process is repeated. This is all done with a minimum of time and effort, and is a very good method of following up the digger.

Fig. 5 shows two men picking up by this method.

The sacks need not be tied, if they are turned open end in when lying on the wagon.

All sorters should be made so that the potatoes can be run directly into the sack, as this saves a great deal of labor. Nothing less than the equivalent of a mesh an inch and three-quarters square should be



Fig. 5 —Two men working together, picking up potatoes in wire baskets.

Courtesy of the Minnesota Experiment Station.

used in any kind of potato sorting, and with the late round varieties a two-inch mesh should be used. While the potatoes are going over the sorter, there should be a man stationed to pick out knobby, scabby and injured tubers. Good, clean, reliable potatoes are sure to bring a better price from the dealer.

Storage—Potatoes should be kept at a temperature not higher than 35° nor less than 32° F. For this reason they are best kept in storage cellars such as are described in Book VII under "Farm Buildings." Low temperatures keep out moulds and rots, and prevent sprouting. A further discussion of the importance of temperature and ventilation in storage will be found in Chapter XII of Book VII, "The Potato Warehouse."

The Selection of Seed Potatoes—Potatoes are perhaps the most easily improved of all our cultivated crops. They practically improve themselves, if a little care is given to their selection.

Dig a few hundred hills by hand from the most thrifty-appearing part of the field before harvesting. Let each hill lie by itself when dug,

and examine the potatoes from them carefully. Do not select the largest tubers from hills having only one large one and several small ones. The chances are that only small potatoes would spring from the seed. Take only those tubers which come from hills containing eight or ten potatoes, each one of which is slightly above medium size and of good shape. Select potatoes from only those hills which come up to the standard you have set, no matter how small the percentage of such hills is. Store these away carefully in the root cellar, and the next spring plant them in marked rows. Next harvest time repeat the sorting process with these rows alone. The selected hills should be planted the second year in a special seed plot, and the rest used in the field. Care should be taken that the seed plot is not on very rich soil, but on the same kind of soils as the potato fields. Otherwise, the improvement may be due mostly to better soil, and the result of the work may be disappointing. The process of selecting the best seed from the seed plot for replanting, and planting the rest in the field can be kept up indefinitely, with surprisingly good results. It should be remembered that the seed plats fall under the laws of rotation, too, and enough plats be supplied to keep a good rotation and at the same time have a seed plat for every year.

If this selection and planting is kept up patiently year after year, it will produce record yields of high-grade potatoes. It is worth trying.

CHAPTER XII

SUGAR BEETS

- I. THE SOIL. II. PREPARATION OF THE SEED-BED. III. MANURING. IV. PLANTING—AMOUNT OF SEED—DEPTH—TIME—TREATMENT OF SEEDS AFTER PLANTING. V. CULTIVATION—THINNING—LATE CULTIVATION. VI. HARVESTING. VII. SELECTION OF BEETS FOR SEED.

The Soil—The best soil for sugar beets is a light clay loam. Where the soils are of a heavy character and the subsoil a stiff clay, subsoiling will increase the yields considerably. Soil that has been in cultivation for some time is better for beet raising than new ground. In general, it may be said that any soil which will produce corn, wheat, or oats to advantage will produce a paying crop of sugar beets.

Preparation of the Seed-Bed—In order to lessen the cost of cultivation, a clean piece of land should be selected for planting. Beets on weedy land are very expensive, because of the excessive amount of cultivation they require.

The soil for sugar beets needs careful preparation. It should be plowed at least 10 inches deep, and in the case of compact soils of heavy clay, a subsoil plow can be used to advantage, loosening the soil to a depth of 15 inches. It is a good practice not to bring all the subsoil into use the first season, because it lacks organic matter (humus). The depth of plowing should be increased a few inches each season. This will in time give a deep seed-bed and at the same time insure enough humus for each crop.

At all times a fine, deep, mellow seed-bed should be prepared by frequent harrowing before the seed is planted. The reason for a deep seed-bed is that unless the beet can readily penetrate the soil, it will grow above the surface. All that part of the beet which projects above the ground is useless for sugar making, for it contains substances which prevent the crystallization of sugar. Another reason, perhaps not so important, is that deep cultivation enables the tap-root to grow down to the water table. This tap-root grows to a surprising length in open soils, and supplies an ample amount of water at all times to the growing beet.

Method of Seeding—Beets should be planted by drill, in rows 30 inches apart to allow the use of the horse cultivator: Larger yields can be obtained by setting the rows 18 inches apart, at an increased expense of cultivation. If a regular beet drill is not available, a cotton or corn drill can be used by regulating the seed drop. If one has a wheat

drill, it can be used as well as the regular beet drill and the expense of a new machine saved. Beet seed should be drilled thickly, a seed pod to every inch is not too thick.

Amount of Seed Required—Drill planting requires from 8 to 10 pounds per acre with 30-inch rows. In hand planting 6 to 8 pounds of seed are sufficient.

Depth to Plant—Beet seeds should go into moist soils, and to obtain this condition, they should be covered to a depth of one and one-half inches. In heavy soils planting less than an inch deep is preferable.

Time to Plant—Early planting is always to be preferred with beets, so as to enable them to get a good growth and develop long tap-roots before the dry season sets in.

Treatment of Seeds for Planting—Beet seeds germinate very slowly, and the process can be hastened, if the land lacks moisture, by soaking the seed in water for twenty-four hours just before seeding. After soaking, they should be drained and then spread out in the wind on a tarpaulin and stirred carefully until they are externally dry. This is a precaution against moulds and fungi which might find their way into the seed if the seed coats were wet. If anything happens to interfere with planting all the seed at once after it has been soaked, it should be covered up with sacks, and it will keep in condition for several days. Most of the seed is planted without soaking.

Cultivation—When the plant first comes up, and during the first few weeks of growth are the critical periods with sugar beets. Where much rain has fallen at or after seeding time and a crust has formed, it must be broken up with a horse weeder. The young plants cannot penetrate this crust, and must be given a chance to get through, or they will die. The plants are very small, and grow slowly at first, so the soil must be stirred with a cultivator as soon as the beets are up and before the usual time for cultivation. It is well to harrow lightly about a week after the plants are up, and to keep the weeds out by regular cultivation.

Thinning—When the young plants show four leaves, they should be thinned, otherwise the beets will never reach full size. If the plants are in 18-inch rows, one vigorous plant should be left every 8 or 10 inches. When the rows are 30 inches apart, the beets may be left closer together, say 6 inches apart. It is better to save vigorous plants, even if the distances are not exactly kept, but no space longer than 12 inches should be left in the rows. Careful selection should be made, and all puny plants destroyed.

Much of the thinning can be done with a narrow hoe; and a hand hoeing at this time is beneficial to the beets. Where the plants are very close together, the work must, of course, be done by hand. When thinning by hand, it is well to save the most vigorous of the discarded

plants to fill in gaps in the rows. If care is taken not to injure the tap-root, they can be transplanted very easily at this stage of their growth.

Late Cultivation—After thinning, the beets should be cultivated once a week for a period of six or eight weeks. If the season is very dry, they should be cultivated even more frequently. This keeps down the weeds, secures a good tilth, and conserves the soil moisture. During cultivation, care should be taken not to injure the leaves or roots, and when the leaves begin to cover the ground pretty well so that no weeds can grow, cultivation may be suspended. The final cultivation should leave the ground practically level.

Here is a point so important that it must not be neglected. In August, when the roots have attained considerable size, the earth should be well ridged up along the rows so that the upper part of the beet shall be well covered.

Harvesting—Harvesting should be done as late as possible, provided that there is no danger of a second growth. The leaves of the beet change from a rich to a yellowish green, and the lower ones die, forming a ring around the beet. This is the signal for harvesting.

Special machinery is necessary for harvesting beets. The most important tool is the loosener. The teeth of the loosener are set at an angle to catch the beet at about its middle part, and break the tap-root. The beet then slips upward and over the prongs, which catch another beet further on. After the harvester passes down the row, the beets may be lifted from their bed by the tops and topped. This consists in cutting away the tops with a large knife, and must be done by hand.

After topping the beets should be thrown in piles and covered with their tops to prevent freezing. They should be taken to the station in dump carts, as they are more easily handled in these than in wagons.

Selection of Beets for Seed—At harvest time those beets which are of the best size and shape should be saved for seed. They should be selected from fields that have shown a high yield and high sugar content, and should weigh about twenty-four ounces. Smaller beets would show a higher sugar content, but it is undesirable to breed a race of small beets. These beets are called "mother" beets, and should be stored carefully in a silo or root cellar. They are not topped, but each leaf is cut off separately close to the base. In the spring they are removed, and the sugar tests made.

This sugar test is usually made free at a local experiment station, or at some sugar factory. It involves expensive apparatus and the technical knowledge of an expert chemist. However, the sugar factories are willing to give their tests free, because better beets mean better business to them. The beets are first numbered on their arrival at the chemist's office. These numerals are cut deep into the side of each beet, so they will last through the season. Then a conical piece

is cut from each beet, and the number of the beet carefully recorded. First the juice is extracted, and a silver button weighed in it to determine its specific gravity. Then some of the juice is placed in a glass cylinder and examined with a polariscope to determine the amount of sugar it contains. The per cent of sugar divided by the specific gravity of the juice gives us the so-called coefficient of purity. The coefficient of purity should be 85 and the per cent of sugar 18, if the beet is to be used for seed.

After the test is completed the beets are returned to the farmer with a record of the sugar content and purity of each beet. He should then plant the "mothers" that rank highest in a special seed plot, and save the seed for his crop next year. A record of the seed of each numbered beet can be kept for a number of years and the quality of the beets bettered indefinitely by careful selection.

It is only fair to say that most of the beet selection is being done by the experiment stations. The larger portions of the seed used in America for the growing of sugar beets comes from Europe but persistent efforts are now in progress to grow the seed in this country. The American beet grower is usually furnished seed for the season's crop by the factory that contracts for his beets, and it is to the interest of the factory that the best seed obtainable is supplied to the grower.



Fig. 1.—Inoculation Increased Yield. The Treated Soil Produced 438 Pounds of Seed An Acre, While the Untreated Portion Produced But 234 Pounds.

Courtesy of the Wisconsin Experiment Station.

CHAPTER XIII.

THE SOY BEAN

- I. THE SEED. II. PREPARATION OF SEED-BED. III. INOCULATION. IV. PLANTING—TIME—METHOD—SPACING—AMOUNT OF SEED. V. CULTIVATION. VI. HARVESTING. VII. STORAGE. VIII. ROTATION.

Of all the legumes grown on extremely sandy soils none is more valuable as a forage for live stock or as an improver of worn out soils than the soy bean.

The Seed—Great care must be taken in the selecting of soy bean seed. It loses its germinating power very rapidly, retaining it only a couple of years under the best conditions and losing it at once upon binburning and heating in the bins. For this reason it must always be tested for germination before planting by growing 10 or 100 of the seeds between blotting papers as described in Chapter I, Book II.

Preparation of Seed-Bed—Soy beans grow best on sandy soils. They will endure acidity in the soil much better than most legumes. Indeed, it is only on poor soils that they become active legumes and restore nitrogen to the soil. On rich soil when not inoculated they simply live like other plants on the soil elements.

Fall plowing is preferable when the soy beans are to be put on clay or clay-loam soils. If planted on loose sandy soils it is preferable to plow in the spring and compact the soil with the roller or plunker after plowing. Always finish the bed by running over it with the smoothing harrow.

Inoculation — The soy bean, in common with all legumes, gets its power of storing nitrogen from certain germs, the nitrogen-fixing bacteria. These enter the roots of the plants from the soil and establish themselves in nodules, where they store up the nitrogen which they take from the air. Unless these bacteria happen to have been left in the soil by some previous crop of soy beans, the beans will not have enough nitrogen to meet their needs except in very rich soils. It is necessary, then, to supply the bacteria, and the method by which it is done is called inoculation.

Patent cultures now on the market have not been very successful.

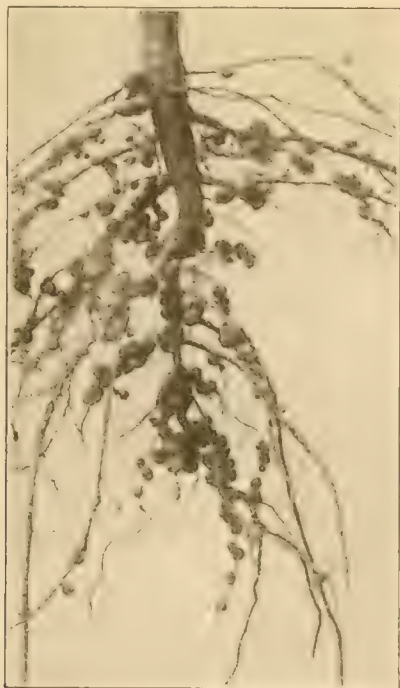

Fig. 2.—A SOY BEAN NITROGEN FACTORY.
Roots of this soil-restoring plant showing nodule development.

Courtesy of the Wisconsin Experiment Station.

Inoculation with soil is much more certain. The safe way to inoculate is to haul earth from some field where soy beans have been grown successfully and broadcast it over your field at the rate of from 200 to 500 pounds to the acre. A smaller amount of soil can be used if mixed and planted with the seed. When used in this way the soil should be run through a sieve to remove all coarse particles and equal parts of seed and soil are then used.

The nitrogen-fixing bacteria are killed readily in direct sunlight. It is, therefore, highly important that the inoculation be made on a

cloudy day or in the evening, and a smoothing harrow run over the field shortly after spreading the inoculating soil.

Planting—As a rule, soy beans should be planted immediately after corn planting time, although the time varies with the condition of the soil and the length of the growing season. When used as a catch crop, they may be planted as late as the middle of June and a good crop of hay secured. When intended for seed, planting should be done immediately after corn planting, while for hay they can be put in later if it is more convenient for the farmer.

Method of Planting—Soy beans grown for their seed should be planted in drills to allow intertillage. On small fields they may be planted with an ordinary garden drill, adjusting the drop properly. On level and carefully prepared land, a corn planter may be used very effectively by substituting blank dropping plates or dropping plates especially prepared for use with the corn planter. Many companies are now supplying such plates. The ordinary grain drill may be adjusted for soy beans by stopping up some of the spouts and allowing the beans to run out only at the desired distances. Solid drills, however,

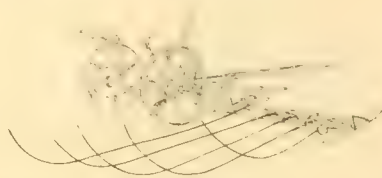

Fig. 3.—Common Mower with Windrowing Attachment.

are not advisable where the desire is to grow the soy beans for seed as it does not allow proper cultivation. No new machinery for planting need be purchased for soy beans. A few adjustments of the corn planter or garden drill or grain drill are all that is necessary.

Spacing—The distance of planting varies with the intended use of the crop. For seed there should be a distance of 30 inches between the rows, with the plants placed in the drill row 2 or 3 inches apart. For hay the rows and plants should be as close together as the grain drill will plant them. Broadcasting is not so desirable with soy beans, as much of the seed is not properly covered.

Amount of Seed—The amount of seed required per acre, when planted for seed, will vary from a third to one-half a bushel. For hay, if broadcasted from 1 to 1½ bushels will be needed, while for solid drills a bushel or more must be used.

Cultivation—Cultivation should begin as soon as the plants are up, and continue at intervals of a week or ten days until they begin to blossom. It should always be shallow, as the soy bean roots feed close to the surface of the ground and are cut off by deep plowing or har-

rowing. Soy beans should never be cultivated when wet with dew or rain. The spores of fungous diseases are spread by such practice and the crop injured to a considerable extent.

When the crop is intended for hay, it is preferable to go through a thorough weed-killing process before planting, providing the beans are to be sown broadcast or drilled as closely as the ordinary grain drill plants.



FIG. 4.—SPECIAL TYPE OF BEAN HARVESTER.

This machine with windrowing attachment, which is often used where the crop is harvested for seed, will cut two rows at once.

Courtesy of the Wisconsin Experiment Station.

Harvesting—Soy beans grown for hay should be cut when the pods are forming and before the plant begins to drop its leaves. If delayed too long the leaves will drop off in drying and most of the valuable part of the crop will be lost.

The crop may be cut with an ordinary mower. A windrow attachment as shown in Fig. 3 aids in the work.

The beans should be cut early in the morning after the dew is off

or late in the afternoon. If cut in the morning they should be put up in small cocks in the afternoon which can be left to cure for several days. When the weather is unfavorable, several cocks may be bunched together and covered with a hay cap. Soy beans, like alfalfa and clover, should not be put up in unprotected stacks. They should be stored in a mow or barn.

Soy beans that are intended for seed should not be allowed to over-ripen but should be cut while some of the pods are slightly green. If fully ripe they will shatter badly in harvesting and during subsequent handling. The crop may be harvested with a grain harvester, with a



FIG. 5.—CORN AND SOY BEANS FOR SILAGE.

When cut and put in the silo with corn (one ton of soy beans to three tons of corn), no objection can be raised to soy beans as a feed for dairy cows.

Courtesy of the Wisconsin Experiment Station.

mower, a bean harvester, or cut by hand with a scythe. Where the mower is used the beans should be moved where they will not be trampled upon.

The bean harvester is the best machine to use for the work on clay-loam soils that are free of stones. It has knives that run just beneath the surface of the ground cutting two rows of beans at a time and placing them in a windrow for curing. These knives should always be kept sharp so as not to pull up the plants and scatter the bean pods.

Soy beans may be threshed without injury by an ordinary thresh-

ing machine if the regular grain concaves are removed and blank concaves used in their place. The threshing cylinder should be run at low speed while the separator should be kept at the same speed as for threshing grain. To accomplish this a larger drive belt pulley is used and a correspondingly larger pulley on the opposite end of the cylinder.

Storage—If soy beans are stored immediately after threshing they are more apt to heat and mould. They should be stored for awhile in barrels or shallow bins, or spread out on the threshing floor where, from time to time, they may be shoveled over until they are thoroughly dry and hard. Later they may be stored safely and more compactly in their regular bins.

Rotations—Soy beans, as legumes, are used primarily for feed and to build up sandy and worn out soils. Unlike clover or alfalfa, they are largely a cultivated crop, thus combining two essential features of a rotational crop. They add nitrogen to the soil, and their tillage destroys many weeds, soil fungi, and moulds which might otherwise remain dormant through several years. In general, soy beans are used like clover, but do not require so long a rotation to be effective, being well adapted to three and four-year rotations. As a rule, they precede the grain crop in the rotation, and leave a seed-bed quite free from disease spores.

A common practice is to plant corn and soy beans together for a silage crop. Some of the best rotations are:

First year—Corn.

Second year—Soy beans.

Third year—Oats with clover seeding

First year—Red clover.

Second year—Corn.

Third year—Corn.

Fourth year—Soy beans.

Fifth year—Wheat.

Another good rotation is:

First year—Corn.

Second year—Potatoes, followed by soy beans.

Third year—Wheat or oats.

Fourth year—Red clover.

This makes use of the soy bean in its capacity of catch crop. Indeed, in almost all cases of crop failure the soy bean can be used as a catch crop and to produce a good stand of hay.

CHAPTER XIV

TIMOTHY

- I. THE SOIL. II. PREPARATION OF SEED-BED. III. SEED SELECTION. IV. PLANTING AMOUNT OF SEED. V. SOWING MIXTURES. VI. MANURE. VII. CULTIVATION. VIII. TIME TO CUT. IX. HARVESTING. X. IMPROVEMENT OF TIMOTHY—THE CLONAL TEST PLAT.

The Soil—Timothy land should not be plowed deep. Timothy requires a good, firm soil to root well, and land which has been plowed eight or ten inches deep is neither rich in humus nor firm in texture. Four to six inches is a sufficient depth to plow.

Preparation of the Seed-Bed—Timothy seed is very fine, with almost microscopic roots. No crop suffers so much from a lumpy soil as timothy, because the seeds which fall between the lumps of earth cannot get water, and they dry up before they become well rooted. A fine tilth should be prepared to a depth of four or more inches to break up the lumps and allow free movements of the grass roots. The soil should be harrowed after plowing, and then cultivated deeply once or twice. The surface of the soil should be left smooth and level before planting.

Timothy seed is so small that it cannot get down to the soil water in time to prevent its drying up after planting. It is absolutely essential that the water should rise by capillary action to the surface of the timothy field, to keep the seed moist enough for germination. The closer the soil is packed, the greater is the capillary action, and the more moisture is supplied for germination and early growth. Therefore, timothy land that is not naturally rather compact should be rolled, to bring the soil particles closer together and increase the capillarity of the soil water. The field should be rolled just before or after the seed has been planted and then finished by running over it with a fine-tooth harrow.

Seed Selection—Timothy seed should be carefully fanned or otherwise selected before planting. A purity and germination test should be made at an experiment station or by the farmer before sowing the seed.

Sowing—Timothy may be sown either with a broadcaster or a drill. Under ordinary conditions, it is best to broadcast the timothy, covering it with a slant-tooth harrow to a depth of half or three-quarters of an inch. This is preferable to drilling, and gives a heavier stand. Moreover, a good grass crop should be a close one, with two or three

plants to the square inch. On dry soils, when even rolling fails to bring sufficient moisture to shallow-planted seeds, timothy can be drilled. Timothy should never be drilled more than an inch deep on any kind of soil. Each seed has enough food material stored up to give the plant a fair start. It can send out its roots and stem so far on its stored up food, but no further. If this store is exhausted before the roots reach water, or before the stem reaches the light, the plant dies, because it must then depend upon its own resources, and it cannot make food for itself without both light and water. The timothy seed, being small, has not a great deal of food material stored away. It cannot send its roots down very deep, or its stem up very far, before the food supply is exhausted. If it is planted even an inch deep, the food is gone before the tiny stem can reach the light, and so the plant must die.

Timothy, then, should never be covered too deep; usually half an inch deep is sufficient.

The Amount of Seed to Sow—When timothy seed is sown too thin, the stems are large and coarse, and the crop is light. A large amount of seed gives a closely matted sward, finer stems, and a larger yield. Where timothy is seeded without clover and other grass mixture, approximately 6 quarts of seed per acre should be used.

Sowing Mixtures—Timothy is frequently sown in mixtures with other grasses and legumes. On the irrigated land of the West, timothy is often seeded with medium red clover. A mixture of clover and timothy, or of alfalfa and timothy will yield more hay than timothy alone, and the legumes tend to replace the nitrogen which the grass removes from the soil. This combination can be used for pasture better than timothy alone, because too close cropping injures the timothy.

Usually, however, timothy is sown in a mixture with other grasses as well as clovers. Not only is the yield higher, but the quality of the hay is also improved.

Alfalfa and clover hays which are rich in protein can be used in the following mixtures:

The Timothy Mixture

Per acre.	Timothy	8 pounds.
	Redtop	8 pounds.
	Mammoth clover	5 pounds.
	Alsike clover	4 pounds.

Another Timothy Mixture

Per acre.	Timothy	10 pounds.
	June grass	8 pounds.
	Alsike clover	5 pounds.
	White clover	2 pounds.

The Pasture Mixture

Per acre. Timothy	6 pounds.
Redtop	8 pounds.
Kentucky bluegrass	8 pounds.
White clover	2 pounds.
Red clover	3 pounds.
Alsike clover	2 pounds.

Cut for hay two years and then leave for pasture.

Manures — Timothy draws heavily on the soil elements. For this reason, it frequently runs out when left for four or five years on the same field, gradually becoming an unprofitable crop. The elements which the timothy takes out of the soil must be returned, or the field will be in very poor shape when another crop is planted.

Timothy uses up nitrogen chiefly. The quickest and best way of returning this element to the soil is by the use of leguminous crops, as clover or alfalfa, in the hay mixture, and following the timothy crop. It also uses up humus, and the best way of returning humus to the soil is by manuring or turning under a clover crop.

From 8 to 10 tons of barnyard manure should be applied to the acre every year. This can best be done by spreading the manure over the stubble with a manure spreader in the fall. There will be no injury to the next year's timothy crop from this practice, since the manure is well rotted before the winter is over and the timothy starts to grow. If coarse manure is used it is well to run over the meadow with the hay rake, gathering straw and other coarse litter which can be put in the compost heap. If a fine-tooth harrow is then run over the ground it will break up the lumps of manure and leave the meadow in good shape for the mower.

Cultivation — Timothy is sown too closely to permit of cultivation. It grows so thick, however, especially when combined with other grasses and legumes, that it kills out the weeds and does not need it.

The Proper Time to Cut Timothy — For cattle, timothy hay should be cut when in full bloom as it contains the greatest amount of digestible nutrients at this time. The correct stage to cut timothy for horse-hay is immediately after the pollen has blown off and no dust remains. While the hay will be lower in digestible nutrients the difference between the stages is not very great.

Just at the surface of the ground on a mature timothy plant will be found a number of small, pointed, solid bulbs. If these be cut off, or if the first two or three short joints are injured, the timothy will be seriously weakened. For this reason, care should be taken not to mow too closely nor to allow close pasturing.

Harvesting — Timothy can be cured more easily for hay than most of the grasses and sheds water quite readily when put in the cock. It

should be cut on a sunny day after the dew is off and left in the swath until the next day. The tedder should then be run over it as soon as the dew is off in the morning, and in the afternoon it can be raked up and cocked. In very good hay weather it can be raked into windrows the second day after cutting, loaded with the hay loader, and taken directly to the barn. If put in cocks it is well to leave it to cure out in the cocks for a day or two. Timothy hay stacks will shed water better than clover, beans, peas, etc. So it may be stacked outside, if barn room is scarce. The tops of the stacks should, nevertheless, be covered with wire grass or blue grass, for the latter, especially wire grass, shed water almost as well as a roof.

THE IMPROVEMENT OF TIMOTHY

When the field is ripening, go over it carefully and choose a number of good ripe seed heads from the tall robust culms of healthy plants. Thresh these separately. Make some small boxes, about 2 feet long by 1 foot 6 inches wide and 4 inches deep. Fill these with good soil from some field on which there has been no timothy for some time. Pack the soil down in the box lightly and smooth off the top, removing all lumps. Now plant the seed from the different heads in these boxes, spacing the rows about two inches apart. Be careful to keep the seed from each head separate, and label it. Sow the seed thickly one-fourth of an inch deep; the plants can be thinned out later so that they stand one inch apart. After the seed is sown, water the boxes with a fine spray in order not to wash out the seeds. Keep the boxes covered with paper until the plants are well up, and keep them well watered.

About September 15, the plants should be transplanted. Select a good field where the plants can remain undisturbed for two years, and set them 2 feet apart in rows 4 feet apart. Plant each row from a single box, or head of grain, so that each row is the progeny of a single selected grain head. In transplanting the seedlings from the boxes, a time must be chosen shortly after a good rain, when the soil is wet. In the early spring the seedlings should be well cultivated and hoed thereafter to keep out the weeds. A few culms will be produced the following summer, and these should be cut early in order that the strength may go into the general growth. When the plants reach the stage for cutting in the second summer, that is, when they are in full bloom, select several of the best plants and mark them by driving stakes down beside them. Also select the best plant in each of the other rows, and mark in the same way. Now cut the crop on all the plants in order to let the fall growth start early.

Between the 5th and 20th of September, choose another uniform plat of rather good soil, located at least 300 feet from a timothy field. Following a rain, dig up each selected plant in turn, separate the bulbs

or slips, and use these in planting a row from each of the marked plants. As before, plant the rows 4 feet apart and the plants 2 feet apart. Transplant about thirty plants for slips from each of the selected plants, so that there will be a single sixty-foot row from each, and cultivate as before. This is the "clonal" test plat.

A good plant from the seeded plat does not mean anything in the selection of timothy. It may be caused by favorable conditions or it may be a plant which will revert to poor quality the next season. But plants which grow from the slips, if they are superior in quality, are improved permanently, and will produce superior offspring.

As in the seeding plat, the clonal test plat cannot be judged until the second season after planting. When the plants are well headed in the second season, go over each row carefully, and examine it for yield and desirability of type, particularly for early and late maturing varieties. Mark two or three of the best rows by stakes, and cut the crop in the discarded rows immediately so that the pollen from these inferior strains may not contaminate the selected rows by cross-pollination.

The seed on the selected rows should be allowed to ripen, and should be sown in the early fall on broadcast plats as large as the amount of seed will permit. There should be enough seed from each row to plant an eighth of an acre. From these multiplication plats, seed can be sown to larger and larger areas until all of the timothy fields have been improved. In the meantime, with the proper care, the clonal plots will live and produce from three to five years, furnishing seed for the multiplication plat. This method of improving timothy can be kept up indefinitely. It is of especial interest to the plant improver but is seldom made use of by the general farmer.

CHAPTER XV

CANADIAN FIELD PEAS

- I. SOIL AND CLIMATE. II. FERTILIZING AND ROTATION. III. PREPARING THE SOIL.
IV. SOWING THE SEED. V. HARVESTING THE SEED CROP.—STORING—THRESHING.
VI. HARVESTING THE HAY CROP. VII. VARIETIES. VIII. DISEASES AND PESTS.
IX. USES OF THE FIELD PEA.

Few farmers know just what Canadian field peas are. They are a large class of peas which includes nearly one hundred varieties. The pea crop is one of the most important in Canada, the annual production being about 14,000,000 bushels. The fact that most of our seed comes from there has probably led to the use of the name, "Canada peas."

Soil and Climate—Peas do best on a clay loam soil, but good crops can be raised on even the stiffest clays. The potash in the latter is probably responsible for this. Non-acid soils with a sufficiency of lime are essential to a profitable crop. Sands do not have the moisture to produce enough growth of vine except in very humid regions, while soils rich in humus produce too much. Poorly drained soils are unfit for pea growing.

Peas will do well in both humid and semi-arid regions, but a region of moderate rainfall with a cool climate is best. Peas cannot endure hot weather, and this is why they are not grown south of the northern tier of states. But since they survive quite heavy frosts and mature for hay in only sixty to one hundred days, and for seed in only eighty to one hundred and twenty days, they are grown successfully in Canada (Ontario especially), Wisconsin, Michigan, Minnesota, the Dakotas, Montana, and the New England States. South of this the cowpea, a sort of bean, takes the place of the field pea.

Fertilizing and Rotation—The Canadian pea is a legume, and can get its nitrogen from the air. On this account it is more economical to apply the manure to some other crop which must get its nitrogen from the soil. Sod land is rich in nitrogen, and so it is advisable to sow some non-leguminous crop on the sod land in preference to peas. Although, peas have been found an excellent crop for subduing a tough sod, it probably will pay better to sow flax or wheat on sod. Because the peas gather nitrogen from the air and store it in the soil, it is better practice to have a grain crop, which needs much nitrogen, follow the pea crop. However, any place in the rotation is suitable for the pea crop, and since diseases of the pea are not doing much damage, the rotation may be short or long, as is convenient.

Preparing the Soil—The land should be plowed in the fall, even

though, relatively speaking, peas will do better on spring plowing than the small grains will. Fine pulverization of the soil is good practice, but is not essential, for the pea has a strong sprout and is a hardy, vigorous grower.

Sowing the Seed—Seed should be sown as early as danger from heavy frost is past. In southern states it is sometimes possible to sow when the cool weather starts and harvest a hay crop before winter. Fall plowing makes early sowing in the spring possible. Early seedings usually yield higher than late seedings. Peas are sown at the rate of $1\frac{1}{2}$ to 3 bushels per acre, depending on the size of seed of the different varieties.

The depth of seeding may vary from 2 to 5 inches. The shallower seeding is better on heavy clays, and the deeper one on light soils or in dry regions. The seed may be broadcasted or drilled. Drilling puts all the seed at the same depth, securing more uniform germination, and experimental tests show slightly larger yields than when the seed is broadcasted. The broadcasted seed may be plowed under, but this puts the seed too deep; it may be harrowed in but this does not put it deep enough. Another method is to broadcast the seed on fall plowed land and then work down the projections with a harrow to cover the seed.

In order to control weeds, the ground should be harrowed just before the peas come up.

Harvesting the Seed Crop—Until recent years the pea crop was harvested with the scythe or with the old-fashioned revolving hayrake. The first method is slow; the second shells out many of the peas, and it so covers the vines with soil as to render the straw practically unfit for use. Happily, a pea harvester has been introduced, by the aid of which the crop may be harvested speedily and in excellent condition on level soils. It is simply an attachment to an ordinary field mower.

The guards in front lift up the peas so that the knife can cut them cleanly. The cut peas fall behind the mower in a string-like row, or swath, and two men with forks bunch them and lay them aside out of the way of the horses. Three men and a span of horses may thus harvest ten acres in a day.

On rear-cut mowers a platform is sometimes used. With this attachment, one man walks behind and with a fork throws the peas off in bunches. But the platform is of doubtful advantage unless the crop is evenly ripened, not too heavy, and free from standing weeds of strong growth. Where the land has been plowed in ridges, with furrows more or less deep between them, the working of the machine will be seriously interfered with.

Storing the Crop—It is usual to turn the bunches over once to hasten drying while they lie on the ground. They require hand loading. The crop may be stored under cover or put into stacks, as with other grain, but it should be borne in mind that peas when in the stack do not readily shed rain, and therefore, the stacks should be carefully topped out with some substance, such as bluegrass or native prairie hay. When the threshed straw is preserved in stacks the same precautions are necessary.

Threshing the Crop—Where only a small quantity is grown annually, and this with the object of providing seed to sow for pasture, soiling, or fodder uses, there is no better way of threshing the peas than by using a flail or by treading them out with horses. The seed is not broken by this method. Where a large acreage is grown it is necessary to thresh peas with a threshing machine, and the best work is done by using the "bar concave."

From this concave all the teeth should be removed except four. These hold the straw in check long enough to enable the cylinder teeth to beat out all the peas. The machine should not run at a high rate of speed. More or less of the seed is likely to be broken. The broken grains, however, may be nearly all removed when preparing the crop for seed or for market, by using fanning mills suitably equipped with sieves. When the crop is wanted for feeding uses, the breaking of the peas does not, of course, lessen its value.

Harvesting the Hay Crop—The peas should be cut when the first pods are full-grown but not yet filled, but it may be put off until the leaves begin to turn yellow. On account of the fact that peas alone average only about one ton of hay per acre, oats and peas are usually sown together at the rate of two bushels of peas and one bushel of oats per acre. The average yield of this mixture is about three tons. This mixed crop is cut when the oats are in the dough stage. The oats will support the peas and make the harvesting of the entire crop easier. The crop may even be allowed to ripen, and the oats and peas be fed together as grain or they may be separated after threshing. The oat and pea hay cannot be stacked outside unless it is covered up with some grass that sheds water well, preferably wire grass or June grass.

Varieties—Some of the more common varieties with their characteristics are given below:

Arthur—Round, yellow, medium-sized seeds; early; productive.

Golden Vine (French June.)—White flower; small, round, cream-colored seeds; medium early; good yields of both forage and seed.

Marrowfat—White flower; cream colored seed; medium to late; large yields of forage and fair seed yields.

Canadian Beauty—Early variety; large vine and fair seed yield.

Prussian Blue—Round, smooth, bluish-green seeds; white flower; late; good yields of both forage and seed.

Diseases and Pests—Diseases of the pea crop are not very destructive. Weeds are kept down by harrowing as directed and by other tillage operations.

One insect, the pea weevil, is a bad enemy of the pea. The eggs are laid in the young pea pod and the larvæ, when they hatch out, burrow into the seeds, where they winter. The next spring the adult beetle emerges. There is only one generation a year and so the adults can be caught by holding the seed over one year, and catching the beetles in a canvas sack as they emerge from the seed. In this way the weevil can be gotten rid

of to a large extent. The pea seed is not harmed by keeping it for two years. It retains its vitality well for five years, but after that it rapidly loses its germinating power.

Uses of the Field Pea Crop—No other grain crop, except perhaps oats, can be devoted to so great a variety of uses. The grain is of high feeding value, and the same is true of the straw. As a pasture for certain kinds of live stock, peas may be made to serve an excellent purpose. The value of the crop for soiling and fodder uses is very great and as a fertilizing crop peas are probably excelled only by clover.

There is no kind of live stock on the farm to which peas can not be fed with positive advantage, when they are to be had at prices not too high. They are not commonly fed to horses, since they can seldom be spared for such a use, but they make a good food for horses at work, and for colts during the period of development, if given as a part of the grain food. As a food for fattening cattle, peas are probably unexcelled. Much of the success which Canadian feeders have achieved in preparing cattle for the block has arisen from the free use of peas in the diet. During the first part of the finishing period they will be found peculiarly helpful in making beef, owing to their relative richness in protein, but they are also a satisfactory food at any stage of the fattening process. During the first half of the finishing period peas will be found superior to corn, but toward the close of the same, corn could probably be fed with greater relative advantage. Peas with oats or wheat bran make an excellent grain food for cattle that are being fattened. Speaking in a general way, peas should form about one-third, by weight, of the meal fed, but, as every feeder knows, the relative proportions of the meal used should vary somewhat as the season of fattening progresses. Peas are fed whole to sheep and poultry and brood sows in the winter. For other stock it is best to grind them. Hogs are often fed soaked peas. The straw is a good roughage for horses, cattle and sheep, but if intended for such use should be cut and cared for accordingly.

As a pasture crop, peas are useful only for hogs and sheep, because cattle trample the ground too much. The one objection to peas as a pasture crop is that it comes too early in the season.

As a soiling crop sown with oats, we may expect from ten to twenty tons per acre at about the time when the spring grasses fail. It has high nutritive value and may be followed by a crop of rape, thus eradicating weeds. The pea is a legume and gathers nitrogen from the air, and in consequence, it is one of the best crops to plow under in order to increase the humus content of the soil and maintain its nitrogen supply.

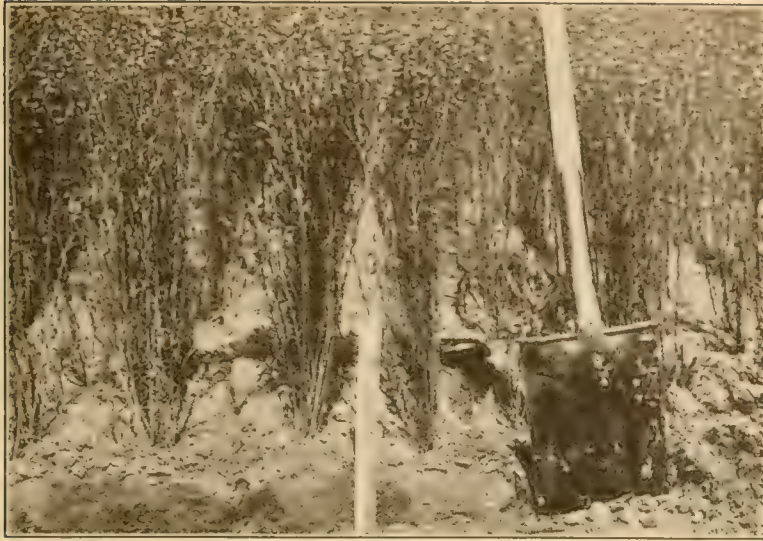

Fig. 1.—A firm seed bed is essential in flax culture. Notice how firm the cross-section of this land is. Flax is best sown in drills.

Courtesy of the Montana and North Dakota Experiment Stations.

CHAPTER XVI

FLAX

I. SOILS AND FERTILITY. II. CLIMATE CONDITIONS. III. DISEASES AND PESTS. IV. SEED SELECTION AND TREATMENT. V. CROP ROTATION. VI. PREPARATION OF SEED-BED. VII. SEEDING. VIII. IRRIGATING FLAX. IX. HARVESTING—THRESHING. X. USES—FLAX ON NEW LAND.

Flax is grown for two purposes; its seed, which is used principally for making linseed oil and stock food, and its straw, which through a special process is changed into fiber and used for the manufacture of tow and linen. The growing of flax for fiber is not common in America largely on account of economic factors. In America the crop is used very frequently to subdue new land.

Soils and Fertility—Flax does not require a very fertile soil. In Russia flax is successfully grown on soils that have become so poor from the long continued “three-year” rotation that they will no longer produce a crop of oats or rye. But it does require a clean soil, that is, one that is free from the spores that produce flax wilt or canker. It will grow on sandy or clayey soils, if they have some humus in them. When manures are applied or green crops plowed under, it should be done for the crop preceding flax, because too much manure causes flax to make too rank a growth at the expense of the seed crop. If applied directly for flax, the applications of manure should be light. Flax is not hard

upon the soil, as is shown by the fact that better crops of wheat can be raised after flax than after wheat and also by the following table.

ACRE YIELDS AND FERTILITY LOSS

	GRAIN				STRAW				TOTAL		
	Yield Bu.	Nitrogen lbs.	Phosphoric Acid lbs.	Potash lbs.	Yield Ton	Nitrogen lbs.	Phosphoric Acid lbs.	Potash lbs.	Nitrogen lbs.	Phosphoric Acid lbs.	Potash lbs.
Corn.....	65	40	18	15	2	46	4	60	86	22	75
Wheat.....	20	25	12.5	7	1	10	7.5	28	35	20	35
Oats.....	50	35	12	10	1½	15	6	35	50	18	45
Flax.....	15	38	15	8	1	17	3.3	21	55	18.3	29

The one essential plant food element upon which the flax plant makes heavy draft, as compared to wheat and oats, is nitrogen. Good farmers know that the nitrogen content of their soil can be maintained by plowing under a legume crop occasionally. Since flax does not remove as much phosphorus and potash as the other crops, it can hardly be said to exhaust a soil very rapidly.

Climatic Conditions—So far as flax is concerned, soil quality is not as important as climate, strains of seed and flax diseases. Flax for seed will mature in from ten to twelve weeks. For the production of a good quality of fiber, the flax plant must have an even, slow development to maturity. A cloudy sky and cool, humid air with a steady but not too great supply of soil moisture are features of all fiber districts. If it is supplied with subsoil moisture, the flax plant will stand very severe conditions of atmospheric heat and drouth.

Diseases and Pests—There are few crops that have as few insect and animal pests as the flax crop. Weeds must not be tolerated in the flax crop. If the flax is to be used for fiber, all the weeds must be picked out by hand before retting. But even in the seed crop, weeds are very injurious because they produce an uneven stand, shade the crop, and their seeds are separated from the flax seed with great difficulty. Pernicious weed seeds commonly found in flax seed are flax dodder, cornflower, mustards, false flax, penny-cress, wild buckwheat, pigeon grass, barnyard grass, and Russian thistle. The farmer should be careful as to what kind of weeds are present in the flax seed he buys.

The only troublesome disease that affects the plant is flax wilt which is caused by a fungus that lives year after year in the soil. Land once infested by this fungus remains infested for many years. The fungus is introduced to new lands chiefly by means of scaly, chaffy, diseased seeds. The disease may be carried to new land by dust, blown or washed from other diseased fields, dragged in by farm implements, or introduced by manure made from diseased flax straw. For this reason all flax straw manure should be well composted before using, and should be applied after the flax crop has occurred in the rotation in preference to applying it before.

Seed treatment, properly done, gives a greatly increased crop whether

the flax wilt fungus is present on the seed or not. Practically all flax seed contains the spores of the fungus and should be treated before sowing.

Seed Selection and Treatment — Flax grown upon flax-sick soil tends to become more resistant each year, provided one saves the seed which each year matures from this crop. Flax seed, so taken from a very badly diseased crop and cleaned in the fanning mill until most light weight seeds have been blown out, is found to be much more resistant than ordinary flax. If this process is followed for three or four seasons on flax-sick soil, almost entirely immune flax seed results. Thus, any farmer who has flax-sick soil can get resistant seed from any of the standard types of flax seed, if this process is followed.

In most cases, seed of highly resistant powers will show some plants which wilt each year. Weak plants, though sick, may produce some light, scaly seeds. Such seeds must be removed by the fanning mill each season or the general crop will tend to lose the resistant powers obtained in the first selection. After the seed has been graded to bright, plump seeds, it is ready for the formaldehyde treatment, to destroy the spores of the fungi in the seeds.

Use the standard strength formaldehyde and use 16 ounces (Avoirdupois) to 40 gallons of water. Wet the flax seed thoroughly in any manner which will do the work and yet not mat the seeds together.

It is easier to treat flax seed for sowing purposes than it is to disinfect any other type of seed grain. Remember that the grains must be evenly wet over the entire surface so that each grain has received the moisture. This can be accomplished if the grain is raked, shoveled or stirred, while a fine forceful spray is being thrown upon it. The grain is most easily treated in a shallow box of convenient size with handles. The treatment should be given outdoors in the field at the time of seeding. Best results have been obtained by sowing the seed while it is yet damp. The grain can be left in the box for a time covered by blankets or canvas, and the seed will take up the excess moisture. Treating the seed once, allowing it to become nearly dry, then treating it again makes success doubly sure.

Crop Rotation — It is on account of this disease and not because of soil exhaustion that flax must be put into a five to seven year rotation. It is either the exclusion or the checking of this disease that influences flax growing at all stages in its cultivation and harvesting, but the farmer's most effective weapons against it are seed treatment and crop rotation.

SUGGESTED ROTATION FOR FLAX

Year	5 Year Rotation	6 Year Rotation	7 Year Rotation
First	Corn	Corn	Corn
Second	Grain	Grain	Grain
Third	Meadow	Grain	Grain
Fourth	Pasture	Meadow	Meadow
Fifth	Flax	Pasture	Pasture
Sixth		Flax	Flax
Seventh			Wheat

All flax straw manures are applied after the flax crop is removed. This gives the corn first chance at the manure and keeps flax off the land as long afterward as possible. Manures free from flax-wilt spores may be applied for the flax crop as a top dressing on the pasture. Such manure must have had no contamination with flax in any way. Wherever grain occurs in the rotation, any small grain may be sown, but the farmer must remember that oats and barley are not as good as wheat and rye for nurse crops for meadow seeding. Meadows are sowed down at the rate of 8 pounds of timothy and 6 pounds red clover per acre. In the seven year rotation, wheat follows flax, because it does better there than after another grain crop, and because any "volunteer" flax that may be in the field ripens with the wheat crop and can be readily separated from it after threshing.

Preparation of Seed-Bed—The one thing flax cannot endure is a loose, friable seed-bed. There are two reasons for this: (1) Flax is a shallow-rooted crop and so must have a compact seed-bed to conduct moisture from the subsoil to the young plant. (2) The organisms that cause the flax diseases thrive best where there is abundant air. A compact seed-bed is injurious to their growth. All cultural operations must have this for their object, and, where dry farming must be practiced, a dust mulch also must be maintained. (See "Dry Farming" in Book VI).

Plowing should be as deep as is possible and still turn the furrow slice completely over so that it lies flat with the sod side down. Subsequent tillage should not disturb this sod but should work it still flatter. The disk harrow is the most useful tool for this purpose. Plowing in the fall is preferable to spring plowing. Whether it is necessary to fallow or not must be determined by the man "on the job." The question is not whether there has been a rainfall of fifteen or sixteen inches during the year, but whether the subsoil does or does not contain moisture enough to carry the crop to maturity. In humid regions the principal object of tillage is a mellow but firm seed-bed.

Seeding—In humid regions flax is sown at the rate of one-half bushel per acre; in arid regions one-third bushel or perhaps only 12 or 14 pounds per acre should be sown if the seed-bed has been well prepared. He who sows on an unprepared seed-bed had better stay by the old rule of sowing about one-half bushel per acre. Every farmer should know just how much his drill is sowing per acre.

Flax seed should be sown about 1 inch deep except in a dry, loose soil where it may be sown as much as 2 inches deep. In some localities the seed is broadcasted and harrowed in. This does not insure an even depth, which is necessary, for the flax crop must grow and mature uniformly. Drilling gives the better results; the seeds all come up at the same time and develop uniformly over the field.

The seeding should be done as soon as the danger from frost is past. Yet if the growing season is short, the farmer should remember that the flax crop, when it is in blossom or when the seeds are not perfectly formed, is very badly injured even by a light freeze. A freeze in the spring means

only lost seed and labor. This is not all loss, for more labor will make a better seed-bed and after all, the entire cost of raising and harvesting flax is only about \$7.00 per acre. Even though frost does not come in the fall in time to prevent maturing of the crop, fall rains and cool nights tend to keep the crop green, and a lot of new seed pods will form and spoil all chances of harvesting an evenly matured crop. So the best rule is to *sow early*.

Irrigating Flax—Flax cannot thrive if water stands on the surface for any length of time, especially during hot weather. It will continue to blossom as long as the moisture supply is high, especially in cool weather. So it is probable that the best results will be obtained by one thorough soaking of the soil either just preceding seeding time or immediately following the stage when the flax is three or four inches high. The wilt disease is most destructive under moist conditions, so for irrigated flax the greatest care should be taken to select clean, healthy seed.

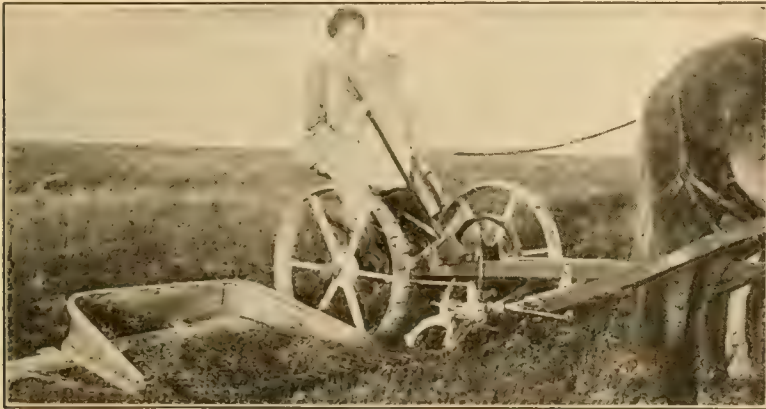

Fig. 2.—The first crop under rough conditions. A buncher attached to the mower is sometimes used on very short flax, but cannot do good work under such ground conditions as here shown.

Courtesy of the Montana and North Dakota Experiment Stations.

Harvesting—The manner of cutting will depend a good deal upon the machinery a man has at his command. The self-rake reaper is at present the best machine for cutting, as it leaves the bundle in handy form and loose. In the bundle it may easily be turned to facilitate drying. The less the crop has to be handled between cutting and threshing the better, especially after it has once received a rain. The binder adds to the cost of production and is likely to cause loss through shattering. If cut with the binder, the bundles should at once be set up in long two-by-two shocks. If wet by rain when in the bundles, there is some danger of loss by mould. Cutting with a mower or scythe is never advisable. Every flax grower should have a seed plot and this should be that which ripens earliest, other things being the same. It is cut as soon as the straw gets dry. It

is allowed to dry in the field for a few days and should then be put under open sheds.

Never allow flax which is to be used for seed to become wet at harvest time, if it can possibly be helped; for, the spores of disease germinate and, like mould filaments, grow into the seed coats, and seed treatment will fail to destroy this internal fungus. The young plants from such seed must eventually sicken or die, and will introduce the disease into the soil wherever they fall.

Threshing—Flax is usually considered a hard grain to thresh. This is often the case but is not particularly a fault of the crop. The trouble usually rests in the methods of handling. Dry, well-cured flax does not necessarily thresh hard or give trouble. No attempt should be made to thresh damp or tough flax. The grain which comes from such damp straw can hardly be saved without considerable loss unless much care is taken to dry the seed after it is threshed. This is an expensive process.

Particular care should be directed to the speed of the separator, the work of the cylinder and the sieves. There should be no end-play in the cylinder.

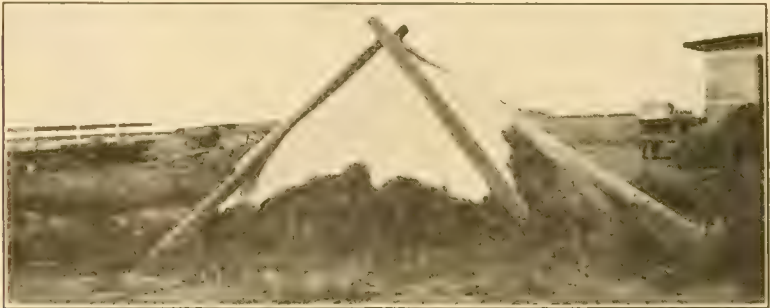

Fig. 3.—Rain spoils flax seed for sowing purposes. The straw should be dry ripe when cut, stacked at once, and covered. See how this homesteader did it.

Courtesy of the Montana and North Dakota Experiment Stations.

End-play there causes cracking or chipping of seed. The loss in dockage, due to cracking, is often 10 to 15 per cent. Cracked or partially cracked seed is often greatly injured for use as seed. The separator should not be run at too high speed. There should be only enough teeth in the concaves to knock out the seed. It is essential to avoid breaking up the straw as much as possible; for, large masses of shives, leaves and chaff clog the concaves and interfere with the work of the sieves. They do not pass over the chaffer but drop through onto the sieves. These become overworked and much seed goes over with the chaff or is thrown into the return elevator and receives a further cracking and injury. In a twelve bar cylinder, the speed should run at approximately 980 to 1,000 revolutions per minute. Most separators are now equipped with the adjustable sieve. In case this is used, a regular flax screen should be placed under it.

Storage, Handling and Shipping—If, at threshing time, the seed

and straw is dry, flax is not more difficult to store or ship than other grain. If not dry, it is very difficult to handle. A small amount of dampness is sufficient to cause heating in bins or bags, and when it begins to heat it quickly mats together and becomes comparatively worthless.

Uses of Flax—The flax seed is used mainly for the manufacture of linseed oil and the residue from this process is oil meal, a much valued stock food on account of its high protein content. Linseed oil is used in the mixing of paints and varnishes and as a laxative in veterinary medicine.

The chaff and screenings are ground up with some other material, perhaps mixed with cheap molasses, and made into commercial stock foods. These often contain as high as 20 per cent of unground weed seeds. There is danger of seeding down the farm to weeds, if any of these feeds are used. They have a high feeding value, as a rule, but the price is set at such a fancy figure that it is probably advisable to purchase the oil meal and be sure of what one is getting.

Flax straw is much richer in protein than other straws. This is a good reason why cattle should like it, if it is not too coarse and is well preserved. If too coarse straw is fed, or if any kind is fed in too large amounts, it seems that there is danger of poisoning, due to some prussic acid in the plant. This is present in all parts of the plant at all times, but in rather small amounts. It varies with the stage of maturity of the plant, the part of the plant, the species of the flax, and also with some external conditions such as weathering.

The other use of flax straw is for fibre. In the United States this industry has not developed, but there are a few tow factories in the Northwest that have a daily capacity of about fifteen to twenty tons of the straw.

Flax on New Land—Flax is one of the best crops to subdue new land and it can be grown continuously, if the flax wilt fungus is excluded. However, it is not advisable to grow flax without rotation even though the soil is able to endure it. Nevertheless, this is the reason why the plant has secured a foothold in the West. It is the cash crop of the pioneer farmer. To keep the new lands from becoming flax-sick, the farmer should cut his crop when it is dry, thresh it when it is dry and never allow the seed to become mouldy or damp if it can possibly be helped.

Since the nation's need for linseed oil will continue, it would certainly be well if flax growing were put on a permanent basis, and it is true, that, when wisely handled in proper rotation, flax can be grown successfully on old land. Flax is a valuable and profitable crop to complete a rotation for small grains. Therefore, it should be a part of farm policy, in the districts where flax is now being grown, to take all of the steps necessary to establish the flax crop on a firm footing in the new agriculture of those regions.

BOOK III
SOILS AND SOIL FERTILITY



FIG. 1. SPREADING PROFITS ON THE FIELDS

Courtesy of the Wisconsin Experiment Station.

SOILS AND SOIL FERTILITY

CHAPTER I.

COMPOSITION OF SOILS

- I. INTRODUCTION. II. THE FERTILITY OF SOILS—NECESSARY ELEMENTS FOR PLANT GROWTH. III. HOW TO DETERMINE SPECIAL ELEMENTS REQUIRED—SOIL ANALYSIS—FIELD OBSERVATION. IV. DEFICIENT ELEMENTS—NITROGEN—PHOSPHORUS—POTASSIUM. V. EFFECT OF CHARACTER OF PREVIOUS CROPS—TABLES NO. 1 AND 2 PLANT FOOD REMOVED BY CROPS. VI. TEXTURE AND STRUCTURE OF SOILS—CLAY SAND—PEAT—LOAM. VII. TESTS BY FERTILIZERS. VIII. PRACTICAL METHODS OF TESTING SOILS FOR ACIDITY AND ALKALINITY—LITMUS PAPER TEST—AMMONIA TEST—LIME TEST.

Introduction—The conservation of soils and their fertility is a problem that deserves more attention than any other connected with our natural resources; for it is on the productivity of the soil that the wealth and prosperity of our nation depends.

There are several factors which determine the productivity of soil among which are light, heat, moisture, air, and plant food. We have more or less control over all of these, least, probably of the first, namely, light. We can control the heat to a certain extent by applying material to the soil which decays and liberates heat, and by adding organic matter or humus to the soil, thereby making it darker and more able to absorb heat from the sun.

We can control the moisture content of most soils either by irrigation of dry land, as is extensively practised in the West, or by drainage of wet lands, as is done in many parts of the country. By drainage of land, by cultivation, by incorporating organic matter in the soil, by keeping the soil porous and open, the soil can be properly supplied with air. One of the most important factors in soil productivity and one often neglected or ignored in some parts of the country is the supply of plant food. This then will form the basis of the discussion and the other points will be discussed in so far as they affect the supply, availability and proper assimilation of food for the plant or crop.

The Fertility of Soils—In regions where the virgin soil is rich in fertility and where other conditions, such as rainfall, absence of poisonous or toxic substances, and proper drainage are favorable, the soil will produce abundant crops. But without the application of fertilizers, direct or indirect, the soil will sooner or later be exhausted, and the farmer must resort to some method to determine the special constituents needed and to estimate the kind and amount of fertilizers.

Necessary Elements for Plant Growth—It should be borne in mind that a plant cannot grow properly and mature seed unless the ten so-called essential elements are supplied. They are:

- | | |
|----------------|---------------|
| 1. Nitrogen. | 6. Magnesium. |
| 2. Phosphorus. | 7. Sulphur. |
| 3. Potassium. | 8. Carbon. |
| 4. Calcium. | 9. Hydrogen. |
| 5. Iron. | 10. Oxygen. |

These may be grouped as follows:

A. Nitrogen, phosphorus and potassium, one or more of which may be lacking in soils that have been under cultivation for a long period of time without fertilization.

B. Carbon, hydrogen and oxygen, obtained from air and water.

C. Magnesium, iron and sulphur, usually abundant in all soils.

D. Calcium, usually existing in sufficient quantities as far as plant food demands are concerned, but sometimes needed in the form of lime carbonate to neutralize sour soils or to improve the physical condition of heavy clay soils.

In speaking of the elements phosphorus and potassium, we often use the terms phosphoric acid for phosphorus and potash for potassium. Phosphoric acid contains only 43.6 per cent of phosphorus, the other 56.4 per cent being oxygen. Potash contains 83.0 per cent of potassium and 17.0 per cent of oxygen.

Lime is a term applied to certain of the calcium compounds, including ground limestone, quicklime, air-slacked lime and water-slacked lime, which are used to neutralize sour soils or improve the physical condition of heavy clay soils. The application of such substances to the soil is called liming. Gypsum, or land plaster, is a calcium compound, but is not called lime.

Gypsum does not correct the acidity of sour soils or make stiff clays more easily tilled. It is used as an indirect fertilizer to liberate plant food that would otherwise be unavailable.

How to Determine Special Elements Required — Several methods have been employed by soil chemists, and other investigators which have been helpful in determining the amount and availability of plant food in the soil, and the amounts utilized by various field crops. They are:

1. Soil analysis.
2. Field observation.
3. Knowledge of character of crops previously grown.
4. Knowledge of texture and structure of soil.
5. Fertilizing tests.

Soil Analysis — The actual value of soil analysis, to determine positively and definitely the actual need of plant food in soils for maximum crop production, has been and still is a matter of dispute. It was formerly thought that the chemist, by means of a chemical analysis, could determine the total amounts of the essential elements present and their distribution in the soil; that he could tell which elements were lacking and to what extent; and also indicate the kind and amount of fertilizers needed for crop production. Such claims are no longer made by reputable chemists, but many uninformed people still adhere to this belief.

The chemist can determine the total amount of plant food in the soil, thus showing what the future crops have to feed on, but his analysis furnishes little information regarding the amount of plant food available from year to year to supply the needs of crops. During recent years chemists have attempted to use such solvents for their tests as would give results that compare favorably with those obtained by actual field tests. For this purpose dilute hydrochloric, nitric, carbonic, and citric acids have been used. The results thus obtained have been compared with crop growth on the fields from which the soil was taken. In some instances the results have been of great assistance in determining the special needs of the soil, but considerable additional information must be used in conjunction with the chemical analysis before it can be interpreted correctly. Chemical analysis alone, therefore, should not be in itself an end, but a means towards an end.

Field Observation — A close and experienced observer can, by watching the development of the crop, learn much regarding the needs of the soil without the aid of a chemical analysis. It must be remembered, however, that the thrift, vigor and color of plants are affected by conditions, other than the supply of available plant food in the soil. A drought would prevent the proper assimilation of plant food even though it may be stored up in the soil in abundance; the plant may suffer from insect pests or fungous diseases; or the soil may be too cold and wet for the bacteria to change plant food into available forms. These factors, therefore, must be considered before the improper growth and maturity of the crop can be attributed to absence of the essential elements.

Deficient Elements—The three elements, one or more of which is often deficient in the soil, are nitrogen, phosphorus and potassium. Their absence affects plant growth in many ways. The appearance of the crop will indicate to a certain limited extent the element which is needed, but too much reliance must not be placed upon the appearance of plants.

Nitrogen—The lack of available nitrogen in a soil is often indicated by a slow growth of the stems and leaves and by a pale green or yellowish color. Such a condition may be due to the fact that there is an insufficient supply of nitrogen in the soil, or it may be caused by cold, wet weather which hinders the development of nitrifying bacteria, thus keeping the nitrogen in the humus from being changed into nitrates which the plant can use. It is usually not difficult to decide which of the two conditions is the cause of the nitrogen hunger. A low total nitrogen content always accompanies a low humus supply and, likewise, a plentiful supply of humus is always accompanied by a large amount of nitrogen. Therefore, if a soil has a good black color, indicating plenty of humus, while the crops are backward and have a poor color, it is very likely that the nitrogen is in an unavailable form and soil conditions must be improved so as to make the nitrogen available. This is especially true if the soil is poorly drained or if the unfavorable conditions are noticeable only during cool wet weather. On the other hand, if the soil is warm and well drained, but lighter in color than similar, uncultivated soil, the absence of a sufficient amount of humus is indicated with an accompanying lack of nitrogen.

Phosphorus—The way a crop matures is an index to the ability of a soil to supply phosphorus to the crop. An early maturing grain crop with plump, smooth and heavy kernels shows a plentiful supply of available phosphorus. If, however, the grain or kernel develops slowly or poorly, and is small, shrunken or withered, the lack of phosphorus is indicated. Some experiments have indicated that a lack of phosphorus is one of the causes of the lodging of grain.

Potassium—Whereas the presence of nitrogen and phosphorus is most easily seen in the condition of grain crops, particularly wheat and oats, the presence of potassium is more noticeable in grass, legume and root crops such as timothy, clover or potatoes. Plenty of potassium is shown by abundant growth of stalk and leaves, as seen in thrifty, vigorous clover, alfalfa, corn, potatoes, or cabbages. The lack of this material in the soil is seen in the small grains when their stems and leaves are weak and brittle. Crops that produce large quantities of starch, such as potatoes and the root crops, generally fail to build a normal amount of starch in the absence of sufficient potassium. This is particularly noticeable in many marsh soils, peats and mucks, which are likely to have a low potassium content.

Effect of Character of Previous Crops—The continuous growing of the same kind of crop may exhaust one or more of the plant food elements more rapidly than another. The continuous growth of clover, for instance, takes only a small amount of phosphorus as compared with potassium;

while grain, such as wheat or barley, exhausts the nitrogen and phosphorus supply more rapidly. Potassium is present, however, in most soils in such large quantities, averaging for the plowed layer of soil from 30,000 to 40,000 pounds per acre, that its easy exhaustion is improbable. Phosphorus averages less than 1,000 pounds in the same layer of soil, and nitrogen averages about 2,000 to 3,500 pounds depending upon the kind of soil. Analysis of soils have demonstrated that 50 to 60 years of exhaustive grain cropping has reduced the phosphorus of the surface layer nearly one-third.

Tables No. 1 and 2, taken from Thorne's "Farm Manures," show clearly how a knowledge of the crops previously grown on a field will aid one in determining the rate at which plant food is being removed from the field. Note that the larger the yield of any given crop the greater the amount of plant food removed.

TABLE No. 1
PLANT FOOD REMOVED BY VARIOUS CROPS

Plant food removed from crops grown on unfertilized land at Pennsylvania State College Experiment Station—25-year average.

Crop and Yield per Acre	Pounds Per Acre			
	Nitrogen	Phosphorus	Potassium	Calcium
Corn 42.1 bushels grain, 1,955 pounds stover...	53.9	10.8	32.6	8.2
Oats 32.3 bushels grain, 1,403 pounds straw....	26.9	5.4	24.7	5.8
Wheat 13.6 bushels grain, 1,403 pounds straw...	21.8	3.2	12.5	2.7
Clover 2,783 pounds hay,	54.8	6.7	43.1	39.8

TABLE No. 2

Plant food removed by crops on partly fertilized land at Ohio Experiment Station—17-year average.

Crop and Yield per Acre	Pounds Per Acre			
	Nitrogen	Phosphorus	Potassium	Calcium
Corn 33.3 bushels grain, 1,811 pounds stover...	43.6	9.0	27.4	7.4
Oats 33.2 bushels grain, 1,386 pounds straw...	27.3	5.5	24.6	5.9
Wheat 24.4 bushels grain, 2,536 pounds straw...	40.5	6.0	23.7	5.4
Clover 2,638 pounds hay	52.0	6.4	40.9	37.7
Timothy 2,990 pounds hay	28.1	4.3	35.3	9.6

Texture and Structure of Soils—There are four general classes of soils:

1. Clay, including the heavy, sticky red clays.
2. Sand, including coarse sands to sandy loams.
3. Loam, including silt loams and clay loams.
4. Peat.

Clay Soils—Clay soils are, as a rule, well supplied with potassium; the nitrogen content is variable; while the phosphorus and lime compounds may be deficient. The application of phosphorus compounds has generally been accompanied by a marked increase of crop yield and frequently the application of lime has been found to be beneficial.

Sandy Soils—Sandy soils are frequently low in both phosphorus and potassium, and if cultivated for some time, are usually low in their nitrogen and humus content. Such soils respond quickly to applications of nitrogen and potassium compounds. Most sandy soils, especially after a few years of cropping, will need lime carbonate.

Loam Soils—Loams are intermediate in texture and composition. This great group of soils, in extent the most important of all, varies widely in its chemical composition depending upon the origin and the kind of management they have received. Lime, nitrogen, and phosphorus are apt to be deficient.

Peat Soils—These soils are generally deficient in phosphorus and potassium and may be deficient in lime also. The application of lime only on acid peat soils has often been accompanied with a marked increase in yield. A partial neutralization of the acid seems to be helpful and fortunately so, since many of these soils are so highly acid that the cost of completely correcting acidity would be prohibitive. Peat soils are well supplied with nitrogen, but when lime is lacking the nitrogen is combined in an insoluble form not readily available to plants. Drainage promotes the growth of bacteria which break down insoluble nitrogenous compounds and render them available for plant growth. Mucks are more thoroughly decomposed than the peats. Field tests should be used to determine the fertilizer requirements of peats and mucks.

Tests by Fertilizers—During recent years the most common method, employed by investigators to determine the kind and amount of fertilizers needed, has been to apply fertilizers of known composition to different portions of the field. Such experiments, if useful results are to be obtained, must be carried on for a number of years for the purpose of equalizing errors due to abnormal weather conditions. The work must be under the supervision of skilled investigators, men who understand the work thoroughly, and who are willing to give to it a reasonable amount of attention. The state experiment stations will usually furnish practical farmers with full information concerning the details of trial tests of fertilizers on a particular farm.

PRACTICAL METHODS FOR TESTING SOILS FOR "SOURNESS" OR ACIDITY AND ALKALINITY

Litmus Paper Test—(Litmus paper of good quality can be secured at any drug store. Five or ten cents' worth will be sufficient.) Place two strips, one blue and one red, of high grade litmus paper in the bottom of an ordinary flat bottomed glass tumbler. Put about a half-inch layer of soil over the test papers, and then add just enough pure water to make the soil moist. Press the damp soil down onto test papers slightly. To obtain pure water collect some rain water in a clean dish placed out in the open air, collecting the water to be used after it has been raining about a half hour. If the soil is moist when sample is taken no more water need be applied. Prepare another tumbler just the same way and add water but no soil; this serves merely as a check on the tumbler containing the soil. Let them both stand for at least one hour. The color of the litmus paper against the clear white back-



FIG. 2—COMMON WEEDS WHICH INDICATE SOIL ACIDITY

Horse-tail Rush, two forms, on right; Sheep Sorrel on left. Fields infested with these weeds are very likely to be acid. (One-half natural size.)

Courtesy of the Wisconsin Experiment Station



FIG. 3.—OTHER WEEDS WHICH USUALLY INDICATE SOIL ACIDITY
Corn Spurry (on left) and Wood Horse-tail. (One-half natural size.)

Courtesy of the Wisconsin Experiment Station.

ground can be examined through the bottom of the tumbler without disturbing the contents. Examine first the tumbler containing no soil. If the color of the litmus paper has changed, then the water contains an acid or an alkali, and the experiment must be discarded. But if the color has remained unchanged, then examine the tumbler containing the soil. If the blue litmus has changed to red, the soil is acid; while if the red litmus has changed to a neutral tint or to blue, the soil is alkaline. The rapidity of the change in either case is some indication of the amount of acid or alkali in the soil.

The Ammonia Test — Put one-fourth of a tumblerful of soil just as it comes from the field into a small fruit jar or tumbler, add three-fourths of a tumblerful of water and two teaspoonfuls of strong ammonia. Stir and let stand several hours. If the liquid becomes dark brown or almost black, the soil is acid; but if the soil contains calcium carbonate or lime, the liquid



Fig. 4.—Liming acid soils for growing alfalfa and clover is very profitable. Courtesy of the Wisconsin Experiment Station.

remains unchanged; or only slightly. This test is of little value when applied to soils lacking in humus or vegetable matter.

Lime Test in Soils — If the foregoing simple tests indicate the need of lime, another test which requires more time and care but which gives the more reliable result should be made by applying lime directly to crops which respond favorably to it. Such crops as clover or beets are grown on small adjoining patches, given the same care and cultivation, and lime is applied to a portion of each patch. Clover may make rapid growth in spring but lacking lime will later cease growing. Beets or other root crops make poor growth if there is lack of lime in the soil. By watching these patches the farmer can determine whether or not it is profitable to apply lime.

Assume that on one of your fields you have observed that crops, say clover or alfalfa, have not made as rapid and heavy growth as you had

expected; you have given the field good drainage, have practised a system of rotation, and have applied fertilizers, in other words, made conditions favorable for maximum crop growth. Yet the soil does not seem to respond to your efforts. Then you should determine whether lime is the material that hinders or prevents proper plant growth.

It is so easy to find out if lime is needed that it should be tested for before any money is spent on fertilizers.

Assume also that the area of your field is ten or more acres and you wish to seed it to oats and clover. It would be unwise to spread lime over the entire field. The following method is better. Apply lime to an acre or two in a narrow strip running through the middle of the field just after the first harrowing in spring. See that it is worked well into the soil by subsequent cultivation. The amount of lime to use and how to apply it is described under "The Treatment of Acid Soils" in Chapter II.

Observe during the summer whether the limed portion of the field is more favorable to crop growth than the unlimed area. The limed and unlimed portions of the field may be harvested and threshed separately and the crop yield per area calculated to determine the exact increase in yield due to lime.

If the limed portion produces enough more oats and clover to pay for the lime and labor involved in application, then its use is warranted. Remember though, that the beneficial effects of lime are shown for several years, so that an increase in the yield on the limed portion the second, third, fourth, and even the fifth year, must be credited to that one application of lime.

CHAPTER II

THE TREATMENT OF SOILS FOR ALKALINITY AND ACIDITY

PART I. TREATMENT OF ALKALI SOILS. PART II. TREATMENT OF ACID SOILS. I. HOW LIME AFFECTS THE SOIL—CORRECTS ACIDITY—MAKES PHOSPHORUS AND POTASSIUM AVAILABLE—IMPROVES PHYSICAL CONDITION—FAVORABLE TO BACTERIAL ACTIVITY—HARMFUL EFFECTS OF LIMING. II. TIME AND FREQUENCY OF APPLICATION. III. LIME COMPOUNDS—WHICH FORMS TO USE—COST—TABLE NO. 3—COMPARATIVE PRICES—AMOUNT TO APPLY—KIND TO USE FOR DIFFERENT CROPS—RAPIDITY OF ACTION—FINENESS OF DIVISION—CONVENIENCE OF HANDLING AND SPREADING. IV. CROPS BENEFITED BY LIMING.

TREATMENT OF ALKALI SOILS

In the north central states and in Canada, areas are limited, where soils are unproductive due to excess of alkali. Nevertheless, farmers occasionally find patches in their fields that are unproductive and tests reveal the presence of toxic or poisonous alkalis. There are only three forms of so called "alkalis" in soils that exist in sufficient quantities to require treatment. They are sodium carbonate, sodium sulphate and sodium chloride. Sodium carbonate is truly toxic in its action, the other two are harmful because the accumulation of such large quantities of salts in a soil prevents water from entering seeds or roots—it is therefore the high concentration of these salts that is harmful. These are all more or less soluble in water and are found in heavy soils, especially where the land is level and drainage is not properly provided for, and where the subsoil is impervious to the passage of water. By growing deep-rooted crops, such as alfalfa, so that the subsoil will become open when the fine roots decay, or otherwise incorporating the soil with organic matter making it more loose and open, the alkalis, during the heavy rains, will be dissolved and carried down into the subsoil beyond the reach of the plants.

When preparing a mildly alkali spot for a crop, deep plowing should be practised, so as to open up the soil and remove the excess of alkali from the surface. Such spots will usually repay in crop production all the labor which is expended upon them, and when brought under cultivation are frequently very fertile.

Where manure, particularly horse manure, can be obtained these alkali areas should be manured very heavily. The advantage of applying manure is that rapid surface evaporation is prevented.

Thorough drainage, if continued long enough, will effect a permanent cure of alkaline soils. When the places are small and located so that they can be under-drained at comparatively little expense, this should be done

as it will prove the best and most permanent way of removing the alkali. Good surface drainage should also be provided. Quite frequently a quarter or more of the total alkali in the soil will, in a dry time, be found near or on the surface. In such cases, and if the spots are small, a large amount of the alkali can be removed by scraping the surfaces and dumping them where they can do no damage.

Oats are about the safest grain crop to seed on an alkali spot because the oat plant is capable of thriving in an alkaline soil where many other grain crops fail.

THE TREATMENT OF ACID SOILS

The use of lime on the soil of some of the northern and central states and in certain parts of Canada, where the soil is acid in character and does not permit proper growth of such valuable crops as clover and alfalfa, has in recent years been of great interest and importance. It has been found by analysis that extensive areas in the northern states, including practically all physical types of soil, are deficient in, and often lack, this valuable ingredient, lime. The unproductiveness of these districts is largely attributed to the insufficiency of lime. It is therefore essential that we consider the subject of liming. We shall treat the subject briefly under the following heads: First, the effect of lime upon the soil; second, the practical use of lime.

How Lime Affects the Soil—It must be borne in mind that lime, when applied to acid soils judiciously is beneficial and materially increases the yield; but when applied in large amounts, in a caustic form, it may prove very harmful and cause a direct loss to the farmer.

Corrects Acidity—Soils that are acid or "sour" are neutralized or made alkaline by the application of lime. Soils that are low in lime content are benefited by its application, because their power of crop production is increased.

Makes Phosphorus and Potassium Available—Phosphorus and potassium, which as we know are among the most valuable elements for plant growth, are often locked up in compounds quite unavailable for plant use. It has been demonstrated that where lime is abundant in the soil these elements are held in a form which the plants can readily utilize. The application of lime helps to set the potassium and phosphorus free, and the crops behave as though these elements were actually applied to the soil.

Improves the Physical Condition—The physical effect of lime when applied to soils is marked. Clay soil is especially benefited in that it is made less sticky, becomes more open and more easily crumbled, making it more tillable and more easily cultivated. Quicklime in particular, tends to improve the physical condition of heavy clay soils.

Favorable to Bacterial Activity—Few beneficial bacteria can thrive or even live in an acid soil. By applying lime, the soil can be made to produce

such crops as clover and alfalfa. Bacteria living on the roots of these plants and other legumes gather nitrogen from the air which is stored in the plant roots and ultimately used by the entire plant. This, of course, greatly increases the nitrogen supply of the soil. There are other bacteria living in the soil which are also constantly oxidizing the organic matter of the soil, and thus unlocking the stores of mineral matter that are tied up in the organic matter, or setting it free, so that it can be utilized by another generation of plants. Whether the beneficial bacteria are living on plant roots or in the soil, they will not thrive in acid soil, so, to promote the bacterial activity in an acid soil, lime should be applied.

Harmful Effects of Liming — As was stated, care must be exercised if liming is to be successful. If too much quicklime is applied, organic matter in the soil is rapidly burned up and the mineral plant food tied up in the organic matter, set free too fast, so that some is leached away. Sandy and gravelly soils need organic matter to increase their water-holding power hence, nothing should be done to hasten the loss of their vegetable matter. For this reason, ground limestone, or some other form of carbonate lime should be used on coarse open soils.

Caution must be exercised in applying lime to a potato field. It has been shown by experiment that although lime tends to produce larger and more uniform tubers, yet it is not desirable to lime the potato crop, because lime favors the production of potato scab. If the field lacks lime, then apply the lime in the crop rotation as far away from the potatoes as possible. Undoubtedly the best time to apply it is when the clover crop is sown. Clover responds favorably to lime, and the bad effect of lime on the potatoes will generally be done away with if the potato crop follows clover. Quicklime must not be applied together with manure. Experiments have demonstrated that if lime and manure are applied together, or if one closely follows the other, there is considerable liberation and loss of nitrogenous compounds.

Time and Frequency of Application — The best time to apply lime is in the spring. If it is applied directly onto the plowed field, it will be thoroughly mixed with the soil in preparing the seed-bed for the crop.

If the farmer finds that he has more time for liming in the fall, and if he practises a system of rotation in which he uses such crops as winter rye or winter wheat and clover, he can apply the lime in the fall just after plowing. The lime should be thoroughly mixed with the soil in preparing the seed-bed for the winter grain. The clover, then, which can be seeded in the spring, and which responds favorably to liming is given the direct benefit of the lime.

Whenever lime is applied to the soil, and whatever system of cropping or rotation is practised, the farmer should apply the lime to crops that respond most favorably to its application. Some of the leguminous and root crops as mentioned elsewhere in this discussion are benefited to the greatest extent. (See "Crops Benefited by Liming.")

In rotations lasting five or six years, one liming will suffice under usual conditions. It is best done at the time when the largest amount of organic matter is in the soil, for example when a green manure crop or sod is plowed under.

We cannot emphasize too strongly the importance of supplying the soil with abundance of vegetable matter along with use of lime.

Lime Compounds—There are various kinds of lime compounds on the market for agricultural purposes. The principal ones are:

1. Quicklime.
2. Slaked lime.
3. Carbonate of lime (ground limestone).



FIG. 5.—AN ALFALFA FIELD TO BE PROUD OF
Alfalfa fields such as this are commonly seen in sections where the soils are well supplied with lime.

Courtesy of the Wisconsin Experiment Station

Which Form of Lime Compound to Use—The particular lime compound that should be used must be determined by each farmer according to his own conditions. These considerations are important:

1. The cost of the lime.
2. The character of the soil and the amounts to apply.
3. The kind of crop.
4. The rapidity of action desired.
5. The fineness of division.
6. Convenience of handling and spreading.

Cost—When the material has to be freighted or drawn a long distance, quicklime in the form of commercial stone-lime, or lump-lime, is found to be cheapest, since it is the most concentrated. In the following table, we show at what price one should be able to purchase good quality

of slaked lime and carbonate or ground limestone, when quicklime of good quality can be purchased at the prices given in the first column. The prices given assume a high grade of purity and equal fineness of division which is not the actual case in the carbonate or limestone.

TABLE NO. 3
TABLE SHOWING COMPARATIVE PRICES FOR DIFFERENT LIME
COMPOUNDS (From Van Slyke's "Fertilizers and Crops")

Cost of 1 ton of quicklime	Equivalent prices for 1 ton of	
	Slaked lime	Carbonate or limestone
\$8.00	\$6.05	\$4.50
7.00	5.30	3.95
6.00	4.55	3.40
5.00	3.80	2.80
4.00	3.05	2.25
3.00	2.30	1.70

Quicklime of high grade can in most cases be purchased for about \$5.00 a ton. To pay for the other compounds according to their neutralizing power, carbonate or ground limestone should cost \$2.80 and slaked lime \$3.80 per ton.

Have your dealer quote you prices on the various lime compounds. Before you buy compare these quotations with the above table and thus determine for yourself which one is the most economical to buy, but always have in mind the kind of soil to which you expect to apply the lime. (See below.)

There are on the market, lime-containing materials sold under various names, such as "agricultural lime," "prepared lime," and "hydrated lime." Some of these are slaked lime, some carbonates or ground limestones and some mixtures of the two. Often their coarseness reduces their efficiency. They are usually sold at prices ranging from \$8 to \$10 a ton, much higher than the best grade of quicklime, pure ground limestone, or slaked lime. Farmers should demand a certified analysis before purchasing any large quantity of lime, or limestone, and should expect to pay for it according to its neutralizing power.

Amount to Apply — On light, sandy or very porous soils and on any soils low in organic matter, applications of quicklime or slaked lime tend to hasten the decomposition of organic matter, unless used in amounts of less than 1,000 pounds to an acre. On such soils it is safer to use ground limestone, which can be applied in large amounts without risk or injury.

On heavy, clay soils and on soils rich in organic matter, quicklime or slaked lime can be used in large amounts, (one or two tons of quicklime and from one and one-half to two and one-half tons of slaked lime per acre) without danger of decomposing organic matter too rapidly.

The rapid decomposing effect that quicklime and slaked lime have on organic matter should always be met by keeping an abundant supply of organic matter or humus in the soil by means either of farm manure or of green crop manuring.

Kind to Use for Different Crops — For crops which are so sensitive to an alkaline condition of the soil as to be injured by it, the use of ground limestone is preferable.

For crops that flourish best in neutral or slightly alkaline soil, quicklime or slaked lime can be used if the application of large amounts is avoided. (See "Crops Benefited by Liming.")

Rapidity of Action Quicklime is changed into slaked lime before it becomes chemically active under ordinary soil conditions. Properly slaked, quicklime forms a finer powder than it is possible to obtain with the ground limestone. It can, therefore, be more thoroughly and uniformly distributed through the soil, enabling it to give quick action. Moreover, quicklime and slaked lime are more soluble in water than ground limestone and thus give a quicker action.



Fig. 6.—Beets grown on acid soil. The lot to the left on a plot to which lime was added, while that on the right was unlimed.

Courtesy of Rhode Island Experiment Station

This solubility is an important factor when a freshly limed soil receives an abundance of rain. A considerable amount of quicklime and slaked lime is readily dissolved and on this account is more quickly and uniformly distributed through the soil.

Both quicklime and slaked lime change completely, sooner or later, to limestone (or carbonate); but some weeks are required to complete the change even under favorable conditions, and while this change is taking place the quicklime and slaked lime must be regarded as more active chemically than limestone.

Fineness of Division — This has been referred to in the preceding paragraph. Quicklime in the form of commercial lump-lime or stone-lime must be slaked in order to permit even distribution in the soil. In properly slaked lime, we have as fine a powder as it is possible to get. Ground limestone is not nearly so fine as well slaked lime. For a more prompt action of ground limestone, not less than 75 per cent should pass through a sieve with one hundred meshes to the linear inch. Where quick action is not desired, some have used with apparent success coarser limestone, 60 per cent passing through a fifty-mesh sieve, but nothing coarser than one-tenth of an inch in diameter. When it will answer the purpose, limestone coarsely ground, has the advantage of costing less than that finely ground.



Fig. 7.—Distributing Lime with a Manure Spreader. Note the lime hood used.

Convenience of Handling and Spreading— The slaking of lump-lime and the distribution of the slaked lime causes some inconvenience and unpleasantness in handling. This disagreeable feature can be avoided by mixing the slaked lime with earth before distributing, or by using ground-burned lime, which is used for building purposes. It is sold in granular condition and the price is reasonable.

This can be handled with comparatively little trouble, because it is usually put up in tight bags and does not require slaking before application. Much of the disagreeableness of distributing fine slaked lime can



Fig. 8.—Limed and Unlimed Alfalfa, Kentucky Experiment Station Farm.
Courtesy of the Kentucky Experiment Station

be avoided by using a lime spreader. Ground limestone is also inconvenient to handle but is less disagreeable than slaked lime. There are on the market drills that are especially made for the distribution of lime compounds.

For small areas, an ordinary shovel is a convenient tool to use. Whatever method is used, liming is attended with good results only when the lime is evenly spread and thoroughly mixed with the soil.

Crops Mostly Benefited by Liming— While some crops are little benefited by liming and thrive only when soils contain it within certain limits, and while some crops thrive best in a distinctly acid medium, yet most of them respond favorably to lime. Among these are leguminous crops such as clover, alfalfa, peas and beans. Also the root crops such as beets and carrots respond most favorably to liberal application of lime. The crops which do not respond to liming are such crops as flax, potatoes, radishes, blackberries, raspberries, and cranberries.



Fig. 12.—Applying Top Dressing on Plowed Ground.

Courtesy of the Wisconsin Experiment Station

CHAPTER III

APPLICATION OF FARM MANURES

- I. COMPOSITION OF BARNYARD MANURES—TABLE NO. 4 SHOWING PERCENTAGE OF PLANT FOOD CONSTITUENTS IN FRESH ANIMAL EXCRETIONS—TABLE NO. 5 SHOWING COMPOSITION OF DRIED OR FREE-FROM-WATER EXCREMENTS. II. IMPORTANCE OF GOOD CARE OF MANURE TO PRESERVE ITS VALUE—NITROGEN LOSSES FROM LEACHING—TABLE NO. 6 LOSS IN HORSE AND COW MANURE—TABLE NO. 7 LOSSES FROM LEACHING—IMPORTANCE OF NITROGEN—BEDDING AS A MEANS OF CONSERVING PLANT FOOD—COMPOSTING AS A MEANS OF CONSERVING PLANT FOOD—COMMERCIAL FERTILIZERS FOR CONSERVING PLANT FOOD. III. METHODS OF USE AND VALUE OF FARM MANURES—TABLE NO. 8 APPROXIMATE VALUE OF PLANT FOOD—TABLE NO. 9 PLANT FOOD CONSTITUENTS PRODUCED ANNUALLY IN EXCREMENTS OF FARM ANIMALS—ORGANIC MATTER IS INCREASED—PLANT FOOD IS MADE AVAILABLE—EFFECT IS LONG CONTINUED—TABLE NO. 10 GAIN IN YIELD OF A MANURED PLOT OVER UNMANURED—MANURE IN RELATION TO DIFFERENT CROPS—MANURE IN RELATION TO DIFFERENT SOILS. IV. AMOUNT, TIME AND FREQUENCY OF MANURE APPLICATION—TABLE NO. 11 PLANT FOOD REMOVED IN THREE YEARS' ROTATION. V. RELATION OF FARMING TO SOIL FERTILITY—TABLE NO. 12 REPLACING FERTILITY BY FEEDING WHEAT BRAN—TABLE NO. 13 EFFECT OF STYLE OF FARMING ON FERTILITY.

Cheapest and Most Convenient Method of Furnishing the Materials a Field May Need—After having determined what elements are deficient in a soil we must supply the needs of the plant in one or more of the following forms:

1. Barnyard manure.
2. Green manures.
3. Commercial fertilizers.

During the past the most common method of furnishing plant food has been the application of barnyard manures. And, wherever available, it is cheaper and more beneficial to the soil than green manures or commercial fertilizers.

COMPOSITION OF BARNYARD MANURE

There are a great many factors which determine the composition

of farm manures. Among them are the age of the animal, amount and kind of food given, amount and kind of bedding used, the extent of plant food lost by exposure, so that a definite composition cannot be given. The following table, however, shows in a general way the composition of manures from the different farm animals. Note the great variations in composition of plant food constituents in the excretions of the various animals.

TABLE No. 4.
PERCENTAGE OF PLANT FOOD CONSTITUENTS IN FRESH ANIMAL
EXCRETIONS (Van Slyke)

Animal	Por on	P cent Excrement	Per cent Water	Per cent Nitrogen	Per cent Phosphorus	Per cent Potassium
Horse	Solid.....	80	75	.55	.13	0.33
	Liquid.....	20	90	1.35	1.04
	Mixed.....	..	78	.70	.11	.45
Cow	Solid.....	70	85	.40	.09	.08
	Liquid.....	30	92	1.00	1.12
	Mixed.....	..	86	.60	.07	.37
Pig	Solid.....	60	80	.55	.22	.33
	Liquid.....	40	97	.40	.04	.37
	Mixed.....	..	87	.50	.15	.33
Sheep	Solid.....	67	60	.75	.22	.37
	Liquid.....	33	85	.35	.02	1.74
	Mixed.....	..	68	.95	.15	.83
Hen	Mixed.....	..	55	1.00	.35	.33

The composition can be expressed more clearly if compared on a water-free basis as illustrated in the following table, taken from Van Slyke. If either the solid or the liquid excrement were dried in an oven all the water they contain would evaporate. What remains would be called "water-free manure." This table will serve to illustrate the importance of using bedding to absorb the liquid portion of the manure.

TABLE No. 5.
COMPOSITION OF DRIED OR FREE-FROM WATER EXCREMENTS (Van Slyke)

Animal	Portion of Excrement	Per cent Nitrogen	Per cent Phosphorus	Per cent Potassium
Horse	Solid portion or bowel discharge.....	2.20	0.53	1.33
	Liquid portion or urinary excrement.....	13.50	10.40
Cow	Solid portion or bowel discharge.....	2.65	0.60	0.54
	Liquid portion or urinary excrement.....	12.50	14.10
Pig	Solid portion or bowel discharge.....	2.75	1.10	1.65
	Liquid portion or urinary excrement.....	13.00	1.75	12.45
Sheep	Solid portion or bowel discharge.....	1.90	0.55	0.95
	Liquid portion or urinary excrement.....	9.00	0.15	11.60

In comparing the above table, observe that composition varies greatly with the different animals and that most of the nitrogen and potassium is contained in the portion coming from the urinary organs while most of the phosphorus is contained in the bowel discharges. The pig furnishes an exception, especially in phosphorus, the greater percentage of which is found in the urinary excrement.

Generally speaking, the average value per year of mixed farm manure is \$30 per 1,000 pounds live weight of animals. A ton of mixed manure contains about 10 pounds of nitrogen at 15 cents per pound; 2 pounds phosphorus at 12 cents, and 8 pounds potassium at 6 cents per pound, making it commercially worth \$2.22.

CARE OF MANURE

It is a common experience for farmers to observe that manure, especially during the warm summer weather, undergoes characteristic changes, such as: formation of distinct odors, rise in temperature, shrinkage in bulk, and a gradual darkening of color. It is of vast importance, therefore, to consider some of the more important changes that occur, and what elements are altered or lost from the manure. During this process of decay, we are especially interested in knowing what changes occur in the three main substances to which manures owe their value, namely, nitrogen, phosphorus, and potassium compounds.

Nitrogen Losses From Leaching—In all fertilizers nitrogen is said to have a manurial value of 15 cents per pound, because it costs that much in the form of nitrate of soda. The fact that nitrogen is so valuable and that it is so easily lost when manure is carelessly handled, more than justifies the use of any rational means of preventing such loss. The greatest source of nitrogen loss in farm manure is by leaching. Extensive experiments carried on show that horse manure, subjected to weathering and leaching for a period of six months, lost 60 per cent of its nitrogen content, while cow manure, due to its more compact form, lost during the same period of time 11 per cent of its nitrogen content.

The following table shows time of exposure and loss of compounds in horse and cow manure:

TABLE No. 6.
LOSSES OF FERTILIZING ELEMENTS IN HORSE AND COW MANURES (Roberts)
LOSS IN HORSE MANURE

	April 25th, pounds	September 28th, pounds	Loss per cent
Gross weight.....	4,000	1,330	57
Nitrogen.....	19.50	7.79	60
Phosphorus.....	6.45	2.96	47
Potassium.....	29.88	7.18	76
Value, per ton.....	\$2.80	\$1.16	

LOSS IN COW MANURE

	April 25th, pounds	September 28th, pounds	Loss per cent
Gross weight.....	10,000	5,125	49
Nitrogen.....	47.00	28.00	41
Phosphorus.....	13.95	11.34	19
Potassium.....	39.84	36.52	8
Value, per ton.....	\$2.29	\$1.60	

At the New Jersey Experiment Station, four samples of manures were exposed to the weather for varying lengths of time and losses determined. The loss amounted to more than 50 per cent.

The aggregate loss over the country due to exposure is appalling. It is estimated, according to the United States census reports, that the



FIG. 9.—COMMON WAY OF LOSING MONEY

Large losses of plant food are sure to occur from these piles of manure. The first rain will take its toll to the creek.

Courtesy of the Wisconsin Experiment Station

annual loss due to the careless handling of manures reaches the enormous sum of \$830,000,000.

TABLE No. 7.
LOSSES IN MANURE FROM LEACHING (New Jersey Experiment Station)

Days exposed	Per cent Nitrogen	Per cent Phosphorus	Per cent Potassium
131	57.0	27.00	59.72
70	44.0	6.98	23.24
76	39.0	27.48	46.48
50	69.0	25.72	59.76

These figures merely show to what extent losses may occur. Ordinarily when manures are left exposed only a comparatively short time losses are not so great.

These losses are caused not only by leaching but the nitrogen especially is apt to be lost by the changes in composition brought about by the action of bacteria and moulds. Such organisms do not affect

the potassium and phosphorus compounds, except to make them more soluble, and therefore more likely to be leached out, but the nitrogen compounds are often so changed in composition that plants are unable to use them as food.

From Table No. 5 giving the composition of barnyard manures, it is seen that on the dry basis, the liquid excrements contain the most valuable portion of manure. This is the portion that is most apt to be lost through decomposition and leaching, because the urine contains those portions of plant food that have been digested by the animal and are, therefore, in a very unstable form and are readily lost. Thus it can be understood that the application of leached or exposed manures shows greatly decreased effect on all farm crops as compared with unleached manures.

The losses of plant food by leaching and decomposition are not confined to the liquid portion, but the solid portion will also, in the course of a few months, decompose, leach and be ultimately lost. Van Slyke in this connection says: "Taking into consideration both the amount and availability of the plant food leached from stable manure, it is not an exaggeration to say that two-thirds of the plant food value is leached from much of the stable manure used on American farms, which means an average loss of \$1.25 a ton at least."

Bedding as a Means of Conserving Plant Food in Manures—The common bedding used on farms is straw, usually from wheat or oats. Other forms of bedding such as shavings and peat moss are used where straw is not so available.

Ordinarily, bedding is low in plant food constituents. It owes its value to its ability of absorbing the liquid portion which would otherwise be readily leached away. Common straw will absorb two-thirds its weight of liquid excrement. The absorptive power of shavings is variable, depending on the kind of wood. The average is from about six to eight times its weight. Peat moss where obtainable is very valuable for absorbing large amounts of liquid excrement. Peat will absorb about ten times its weight. It is also valuable for its ability to absorb disagreeable odors in barns such as ammonia gas, which can later be made into available plant food when applied to the soil. Too much bedding is not desirable. It decreases the percentage of plant food in the manure. The bulk of manure is also increased making the cost of handling too high for all practical purposes although it does not add to the amount of organic matter in the soil.

Composting as a Means of Conserving Plant Food in Manures—When the manure cannot be applied to the field directly and at once incorporated with the soil, the manure should be composted. This consists in making a heap or pile of alternate layers of fresh manure and absorbents (well rotted manure or earth). Care must be exercised to prevent too rapid fermentation of the heap, by applying sufficient

moisture at the time of formation, and occasionally afterwards if the weather is dry. The heap must also be compacted to prevent the action of destructive bacteria. The purpose of the absorbent is to take up ammonia and nitrogen gas escaping from the manure. It also serves as a reservoir for the water in the heap, thus preventing rapid fermentation, holding at the same time any phosphorus and potassium which is in a water-soluble condition. Composting is especially recommended for manures low in water content such as horse and sheep manures, and where much bedding is used. Composting is also recommended for



FIG. 10.—A GOOD MANURE RICK

A cheap and proper way to store manure. This pile is depressed in the center.

Courtesy of the Wisconsin Experiment Station

manure containing noxious weed seeds and plant disease germs whose virulence is thus destroyed.

Commercial Fertilizers Used for Conserving Plant Food in Manures—Land plaster, ground rock phosphate, acid phosphate and kainit are often used to advantage as absorbents in connection with manures. Their value as such will be discussed under Chapter V, "Commercial Fertilizers."

METHODS OF USE AND VALUE OF FARM MANURES

The long continued use of farm manures as a source of plant food to the soil has been well justified. Extensive experiments have been

carried on at the various experiment stations, comparing farm manures and commercial fertilizers. It has been clearly demonstrated that in the long run the main crop growing constituents, nitrogen, phosphorus, and potassium in manures are fully as valuable, pound for pound, as those contained in commercial fertilizers. Aside from this, manure has a large amount of valuable organic matter which commercial fertilizers do not possess. It is difficult to assign a definite value to the different farm manures due to the different kinds of soil and crops to which they are applied, the varying digestibility of different kinds of animal feed, and the extent of leaching.

The following tables show a fair estimate of manure value from different classes of stock:

TABLE NO. 8.
APPROXIMATE VALUE OF PLANT FOOD IN ONE TON OF AVERAGE MANURES (Van Slyke)

Horse	\$2.50
Cow	2.20
Pig	2.00
Sheep	3.20
Steer	2.35
Hen	4.40

The following table is especially practical because the farmer can make a close approximation of the value of his manure heap if properly cared for:

TABLE No. 9.
PLANT FOOD CONSTITUENTS PRODUCED ANNUALLY IN EXCREMENTS OF FARM ANIMALS (Van Slyke)

Animal	Weight.	Nitrogen	Phosphorus	Potassium	Value of plant food constituents for one year
Horse	900 Lbs.	115 Lbs.	17 Lbs.	77 Lbs.	\$21.25
	1100 Lbs.	140 Lbs.	21 Lbs.	94 Lbs.	26.00
	1200 Lbs.	154 Lbs.	23 Lbs.	103 Lbs.	28.30
Cow	800 Lbs.	125 Lbs.	13 Lbs.	85 Lbs.	23.70
	900 Lbs.	140 Lbs.	15 Lbs.	95 Lbs.	26.65
	1100 Lbs.	172 Lbs.	19 Lbs.	116 Lbs.	32.55
Pig	100 Lbs.	15 Lbs.	5 Lbs.	11 Lbs.	3.00
	150 Lbs.	23 Lbs.	7 Lbs.	16 Lbs.	4.50
	200 Lbs.	30 Lbs.	9 Lbs.	21 Lbs.	6.00
Sheep	100 Lbs.	12 Lbs.	2 Lbs.	11 Lbs.	2.40
	150 Lbs.	18 Lbs.	3 Lbs.	16 Lbs.	3.60
Hen (100)	400 Lbs.	34 Lbs.	12 Lbs.	11 Lbs.	7.45
	500 Lbs.	43 Lbs.	15 Lbs.	13 Lbs.	9.30

Commercial fertilizer manufacturers in comparing the fertilizing value of their products to farm manures, often consider the main constituents, nitrogen, phosphorus, and potassium only. Farm manures have special value in crop growth besides furnishing the nitrogen, phosphorus, and potassium compounds. We shall now consider briefly, the various ways soils are benefited by farm manures other than furnishing these nutrients.

Organic Matter is Increased — The fact that all farm manures contain large amounts of organic matter with all its capacity to improve the physical condition of the soil, gives it an added value equally as important as the nutrients which are furnished. It is a well known fact that soils with a generous supply of organic matter are decidedly more resistant to droughts than soils lacking this constituent. Rains are taken into the soil and held until utilized by plants. Clay soils become more open, enabling roots to easily penetrate deep into the soil gathering plant food and absorbing moisture in dry seasons. Clay soils also become less sticky and consequently easier to work when manure is applied. In sandy soils the particles are bound together, reducing leaching, evaporation and plant food loss to a minimum. Soils supplied with humus become darker in color and warm up earlier in the spring, thus lengthening the growing season. This is especially important in the northern states where it is necessary to secure early maturity of crops to escape the early frosts in the fall.

Plant Food is Made Available — During the decomposition of organic matter in the soil, acid compounds are formed which dissolve mineral constituents, such as phosphorus and potassium, and render them available for plant growth. Organic matter in the soil furnishes a good medium for the micro-organisms or bacteria that change the insoluble nitrogen compounds into forms that can be taken up and utilized by the plant.

Effect is Long Continued — That the beneficial effects of applying barnyard manures are of long duration has been clearly demonstrated by Hall at the Rothamsted Experiment Station. During a period of seven years, fourteen tons per acre of barnyard manure were annually applied. The land was then left unmanured for a period of forty years. During this time crops grown on the manured plots were compared with those of similar plots to which no manure or commercial fertilizer had been applied. The greatest gain in yield over the unmanured area was two years after the last application of manure. The gain was 120 per cent.

TABLE No. 10.
GAIN IN YIELD FOR A PERIOD OF 40 YEARS OF A MANURED PLOT OVER ONE TO WHICH NO MANURE WAS ADDED

Period	Increase of yield
	Per cent
First 10-year period after applying manure.....	57
Second 10-year period after applying manure.....	24
Third 10-year period after applying manure.....	6
Fourth 10-year period after applying manure.....	15

Similar experiments with barley were conducted at the Rothamsted Station. Fourteen tons of farm manure were applied annually to a field for a period of twenty years (1852-1871) and then it was left

unmanured. This plot was compared with one that never had received manure. The yields on the previously manured plot are still more than double those of the unmanured field.

Relations to Different Crops—Most crops respond favorably to a liberal application of manure. Yet the farmer must exercise due caution if maximum returns are to be obtained, for all crops are not equally benefited by its application.

We shall now briefly consider some of the crops that are especially benefited by a large application, together with those that are more sensitive and which are apt to be injured if manure is not judiciously applied.

The following brief suggestions adapted from Van Slyke, will serve as practical guides:

1. Grass lands are generally much benefited by top dressing with farm manure either fresh or fermented. The manure serves in addition to furnishing plant food, to form a mulch often favoring somewhat earlier growth.

2. Root crops usually respond most satisfactorily to generous applications of farm manure. However, some precautions in its use must be observed in the case of sugar beets and potatoes. The use of excessive amounts of fresh farm manure, especially on light soils and loams, may cause beets to grow very large but with a low per cent of sugar. On clay soils fairly large amounts, twenty tons per acre of partly rotted manure, may be used directly without harm. In case of potatoes, direct use of stable manure causes scab, and excessive amounts of fresh manure produce over-growth of top at the expense of the yield of the tubers. Green manuring with clover is particularly valuable for potatoes.

3. Corn, millet and leafy crops in general, which produce large amounts of leaves and stems, utilize to advantage generous amounts of stable manure when directly applied, whether fresh or rotted.

4. Cereals are injured by large direct applications of fresh manure. The straw grows very large at the expense of the grain and lodges easily. Wheat and barley are particularly sensitive in this respect.

5. Tobacco, when directly treated with large amounts of stable manure produces large leaves of coarse texture and poor quality for use for certain purposes. Growers of "binder" tobacco have used manure in large quantities to great advantage. The tendency, however in tobacco growing has been to over-manure and not to grow enough clover.

6. Flax may also be unfavorably affected in quality by direct application of too much farm manure.

7. Garden crops in general respond very satisfactorily to generous application of manure.

8. Young trees, shrubbery, rose bushes, etc., are greatly benefited by application of stable manure; moderate in case of fresh manure, generous in case of well rotted.

9. As a mulch in connection with any growing plant, good stable manure is extremely effective and useful. Rotted manure is, of course, superior to fresh manure for mulching purposes on account of its greater water-holding power.



FIG. 11.—THE CARRIER DOES NOT ALWAYS SAVE THE MANURE
Where carriers are used and the manure dumped into a loose pile, great losses may result.
Courtesy of the Wisconsin Experiment Station

Manure in Relation to Different Soils—While it is known that all soils when deficient in organic matter are benefited more or less by the application of barnyard manure, yet there are instances when the farmer must be cautious and apply manure in only limited amounts. If for instance, large amounts of fresh manure are applied to a light sandy soil during a hot dry summer it will decay so slowly that the plants will suffer from food starvation. This would occur especially when

coarse-textured manure is applied, making the soil porous, thus admitting an excessive amount of air to take up the moisture in the upper layers of the soil. The soil also becomes too porous for the capillary movement of water from the subsoil. On the other hand, if the season should be a wet one, the plant could not assimilate the plant food as fast as the manure-decomposing bacteria made it available. The nitrogen then would either be lost by leaching through the subsoil, or by passing off at the surface in the form of nitrogen and ammonia gas. The best practice, therefore, on sandy soils is to apply manure more often and in more limited quantities. For open soils, partly decomposed manure is better than fresh. It can be easily incorporated with the soil, making it retentive of plant food, and preventing the plant food from being carried down below the reach of plants. It also acts as a reservoir or sponge, for holding water and decreases evaporation of water at the surface and leaching into the subsoil. Generally



FIG. 13.—BAD WAY TO USE GOOD MANURE

This is common practice, but costs too much in labor and time. It may also give a spotted field.

Courtesy of the Wisconsin Experiment Station.

speaking, on heavy soils, clay and loam, generous applications of barnyard manure whether fresh or decomposed are highly beneficial. Peat soils are usually benefited by the application of farm manure, but since the organic matter in manure is wasted on such soil, commercial fertilizers are the most economical to apply.

AMOUNT, TIME AND FREQUENCY OF MANURE APPLICATION

No definite fixed amount of manure to apply to the growing crop can be given. It will depend on the frequency of application, the quality of the manure, the nature of the crop grown, the fertility of the soil, and the kind of soil. On the average farm not enough manure is produced annually to cover the entire farm. The best method then, is to apply the manure every three, or four, or five years in the rotation. It has been demonstrated that the greatest conservation of manure has been effected by applying it broadcast when fresh to meadows, preceding

cultivated crops such as corn or potatoes and incorporating it with the soil at once, to prevent surface decomposition and loss of nitrogen compounds.

Another effective method is to apply the manure to the plowed land in the late fall or early spring before the cultivated crop, and drag or harrow immediately; thus incorporating the manure with the soil before nitrogen loss occurs. The disadvantage of the latter method is that plowed land, due to its loose condition, makes spreading heavy.

The practice of hauling manure to the field and throwing it into heaps has several serious objections. A large part of the nitrogen compounds is lost by decomposition due to its exposed condition, and then too, most of the soluble compounds are, during heavy rains, leached



FIG. 14.—THE RESULT OF PILING MANURE IN THE FIELD

A meadow, with uneven growth of grass. This is due to localized fertility. The manure should be spread when hauled.

Courtesy of the Wisconsin Experiment Station.

into the soil directly under and around the heap. The following crop in such places makes rank growth with a tendency to lodge. The crop also matures very unevenly, as shown in Fig. 14.

As was stated, a definite amount of manure to apply can not be given. In general, five or six tons per acre is considered low, twenty tons high, and from ten to fifteen tons about right for most farm crops. Large amounts can be better utilized if the soil is well supplied with calcium carbonate or lime, as it is usually called. Generally, however, the most economical method is to apply moderate amounts frequently rather than large amounts occasionally. The following table will suggest, in a general way, the amounts of manure needed in an ordinary system of crop rotation:

The table shows that about fifteen tons of manure would be required every three years to replace plant food removed by the crop in the rotation. Note that no account is taken of the gain in nitrogen in the soil obtained from the air by bacteria on the clover-plant roots.

TABLE No. 11.
PLANT FOOD REMOVED IN THREE-YEAR ROTATION AND APPROXIMATE AMOUNT OF
MANURE NEEDED (Adapted from Wis. Bul. 221.)

Crops	Pounds dry matter	Pounds nitrogen	Pounds phosphorus	Pounds potassium
Corn grain, 30 bu.....	1500	28	4.36	5.4
Corn stalk.....	1877	15	3.49	24.7
Barley grain, 40 bu.....	1747	35	6.98	8.1
Barley straw.....	2080	14	2.05	21.5
Red clover, 2 tons.....	3763	98	10.86	69.2
Total removed.....		190	27.7	129.
Manure, 10 tons.....		100	21.8	83.
Manure, 15 tons.....		150	32.7	124.5

RELATION OF FARMING TO SOIL FERTILITY

Many authorities in agriculture are of the opinion that under a system of animal husbandry, where only animals and their products are sold from the farm and where the fertilizers are well preserved and returned to the soil, the productivity of the soil can be indefinitely maintained. This, however, is not possible. Only about 80 per cent of the nutrients in the feed is returned to the soil in the form of fertilizers. The other 20 per cent goes to the production of beef, milk, etc. However, if mill feed, such as oil meal, bran and shorts is purchased and used on the farm, the productivity under good management can be maintained or even increased. The following table serves to illustrate how this can be accomplished.

The calculations are based on a farm of from 160 to 200 acres. Only potassium and phosphorus are considered. Nitrogen for plant production can be maintained through the growth of leguminous crops.

TABLE No. 12
REPLACING FERTILITY BY FEEDING WHEAT BRAN (Adapted from Wis. Bul. 221)

	Pounds	Pounds potassium	Pounds phosphorus
Live-stock sold.....	20,000	33.20	130.80
Milk sold.....	146,000	207.50	114.23
Total sold.....	166,000	240.70	245.03
Bran purchased.....	18,000	253.98	274.68

It will be seen that the purchase of only nine tons of bran would sustain the loss incurred by sale of beef and other farm products. The Minnesota Experiment Station shows how the different types of farming carried on in the state affect the permanence of fertility in soils. Four

farms each containing 160 acres and producing average yields of Minnesota grown crops were assumed. On the first, grain only was produced and sold. The second was about equally divided between stock and grain farming. The third and fourth were devoted to stock-raising and dairying respectively. It is assumed that only a small amount of mill feed was purchased for feeding. The figures represent pounds of loss or gain of material in one year.

TABLE No. 13.
EFFECT OF STYLE OF FARMING ON FERTILITY (Adapted from Minn. Bul. 41.)

Kind of farming	Gain or Loss of Fertility		
	Pounds nitrogen	Pounds phosphorus	Pounds potassium
All grain.....	5600 loss	1090 loss	3509 loss
Mixed.....	1100 loss	436 loss	830 loss
Stock.....	1100 loss	21.8 gain	49.8 gain
Dairy.....	1200 gain	32.7 gain	70.55 gain

Under conditions assumed there would be a slight loss of potassium, a slight gain of phosphorus, a decided gain of nitrogen. The great increase of nitrogen is due to the growth of leguminous crops, such as clover, alfalfa or peas.

By the proper handling of barnyard manure, by growing legumes and feeding them to stock on the farm, and by the purchase of mill feeds, the fertility of soils can be permanently maintained.



FIG. 15. ADD HUMUS BY PLOWING UNDER CLOVER

The advantage of plowing under a crop of red clover on sandy soils is shown by this corn, the yield being increased nearly 50 per cent where a clover sod was turned under the previous year for green manure.

Courtesy of the Wisconsin Experiment Station.

CHAPTER IV.

THE VALUE OF GREEN MANURING

- I. EFFECTS OF GREEN MANURING—ORGANIC MATTER IS ADDED—NITROGEN IS ADDED.
- II. GREEN MANURE CROPS—LEGUMINOUS—RED CLOVER—MAMMOTH CLOVER—ALSIKE CLOVER—FIELD PEAS—SWEET CLOVER—HAIRY VETCH—NON-LEGUMINOUS—USEFUL IN ORCHARDS.
- III. THE USE OF GREEN MANURES—SOILS MUST BE LIMED—TREATMENT OF ACID SOILS—EFFECT ON SUCCEEDING CROPS.

Green manures are crops grown for the purpose of being plowed under to add plant food and to improve the physical condition of the soil for the benefit of succeeding crops. The effect of green manuring varies with the character of the soil. Loamy soils with normal supply of plant food show but slight gain by green manuring. Sandy soils, due to the added organic matter become darker in color and cohesive.

This organic matter lessens washing and blowing and acts as a reservoir for water in the soil. Clay soils become more loose and open, making the soils less liable to bake or puddle, and making conditions favorable for the action of beneficial bacteria in the soil.

EFFECTS OF GREEN MANURING

Organic Matter Added—The most important object achieved by green manuring is the addition of organic matter to the soils with all its attendant beneficial effects as discussed in Chapter III. The amount of organic matter formed varies, depending on the kind and extent of growth of the crop. Van Slyke estimates the organic matter at from five to ten tons per acre, roots included, of green material, or from one to two tons of dry matter per year. Hopkins of the Illinois Agricultural College estimates the manurial value of a good crop of green manure equivalent to from twenty to twenty-five tons of farm manure as it is ordinarily applied. It is assumed, of course, that the farm manure has been exposed more or less to leaching rains and fermentation.

Nitrogen Taken from Air Is Added—It is a well established and generally known fact that nitrogen makes up about three-fourths of the total atmosphere, and that certain organisms living in nodules on the roots of leguminous plants have the power to take this free nitrogen of the air and fix it in a form suitable for plant growth. These bacteria draw on the inexhaustible supply in the air and store it in a form that is available to other farm crops.

It is because of this nitrogen and the added organic matter that, where a good growth of such legumes as red clover, white clover, alfalfa or vetch is secured on soils more or less run down, the yield is often increased by one-half for at least two seasons. Marked increases of yield are generally noticed for several succeeding years.

Several experiment stations have carried on experiments to determine the amount of nitrogen actually fixed by bacteria. At the Illinois station a number of experiments have been conducted which show how bacteria are instrumental in adding to the supply of nitrogen in the soil. Both pot and field experiments were conducted, the latter being, of course, more valuable because they are under natural field conditions.

In the field experiment, the "gathered" nitrogen due to bacteria on alfalfa in one plot during one season was 17½ pounds. This valued at fifteen cents a pound amounts to \$25.80. In another plot in the same experiment 25½ pounds of nitrogen from the air were added which at fifteen cents a pound is worth \$37.80. Sixty-five to seventy per cent of the total nitrogen content of alfalfa is taken from the air. The rest is taken from the nitrogen already in the soil. The Illinois station conducted also a series of pot cultures. These are less reliable as a means of determining nitrogen added, but the results obtained compared favorably with the field experiment.

The Dominion of Canada Experiment Station (Reports of 1905) shows that the nitrogen increase of the soil to a depth of nine inches by growing clover two successive seasons, was 179 pounds per acre. Cuttings and residues being returned to the soil, the nitrogen content in the upper four inches of soil was increased 175 pounds. Attention, however, is called to the fact that the nitrogen content of the soils in both of these experiments was low at the beginning. The percentage of total nitrogen taken from the air in this experiment was approximately sixty-five per cent.



FIG. 16.—WHEN NEEDED, LEGUMES ADD NITROGEN TO SOIL

The effect of nitrogen fertilization on the formation of nodules on soy beans is shown above. The plants on the left received no fertilization and produced numerous nodules, while those on the right were fertilized with ammonium sulphate and produced no nodules. This indicates that legumes will draw nitrogen from the air only when there is a lack of it in the soil.

Courtesy of the Wisconsin Experiment Station.

At the Pennsylvania Experiment Station it was found that clover secured about the same percentage of its nitrogen from the air.

It will be seen then that the amount of nitrogen obtained by the growth of legumes varies. But the nitrogen-fixing power of all is sufficiently high to warrant their growth when soils are low in organic or vegetable content. Bacteria on clover, alfalfa and other legumes, take nitrogen from the soil in preference to taking it from the air, so that soils well supplied with organic matter and nitrogen show slight gain from the use of green manures. In rich soils there is but little development of root tubercles and the fixation of atmospheric nitrogen

is slight. The growing of legumes, therefore, enriches the soil in proportion to its poverty.

From the experimental data here presented and from many other experiments similarly conducted, it may be said that on normally productive soils about two-thirds of the total nitrogen content of the legume plant is taken from the air and only one-third from the soil; so that if one-third of the nitrogen of the entire plant is in the roots and stubble, and two-thirds in the crop harvested, the soil would neither gain nor lose in nitrogen from the legume crop. The soil has furnished as much nitrogen to the plant as remains in the roots and stubble.

GREEN MANURE CROPS

The value of green manure crops depends upon their adaptability in growth and upon their ability to gather and store atmospheric nitrogen.

There are various kinds of green manure crops, but they may be divided into two groups:

1. Legumes, which add to the nitrogen supply of the soil such as clover and alfalfa.

2. Non-legumes, such as rye and buckwheat, which do not add to the nitrogen supply, but merely store the nitrogen already existing in available form in the soil, thus preventing the direct loss of nitrogen and preserving it for succeeding crops.

Nitrogen-Gathering or Leguminous — The value of a green manure crop, as just stated, depends largely on its adaptability. There are several green manure crops grown successfully and with profit in the southern and eastern states that are not adapted to the north central states, and Canada. We shall consider only those that are sufficiently well established and practical for northern conditions. They are red clover, mammoth clover, alsike clover, field peas, sweet clover and hairy vetch.

The following statements largely adapted from Van Slyke concerning the management of leguminous crops will serve as practical guides:

Red clover as a green crop manure is probably the most widely grown of any legume. Even the stubble and roots alone are often effective when plowed under. From thirty-three to forty per cent of the entire plant-food value is contained in the roots and stubble. While adapted to a great variety of soils, red clover thrives best on well drained, moderately heavy loam, somewhat moist but not wet, well supplied with organic matter and lime. Even on light soils, it gives large yields when water and plant food are abundant, but runs out sooner than on heavier soils. Red clover is most commonly seeded on winter wheat or rye in the spring, after danger of heavy frost is past and while the ground is moist. Another common method is to seed it with annual crops such as wheat, flax or barley. But for quick

growth, which is desirable in green manuring, it is usually best to seed it alone. When put in as green manure crop from 12 to 15 pounds of seed per acre is used, the amount varying with climatic conditions and kind of soil. Red clover is a vigorous nitrogen-gatherer, an entire crop including roots and tops, often contains per acre 100 pounds of nitrogen and 83 pounds of potassium, and from 18 to 22 pounds of phosphorus.

Clover responds very favorably, especially on light soils to applications of commercial fertilizers containing phosphoric acid and potash. Nitrogen need not be supplied because the plant secures its nitrogen supply from air through the action of nitrogen-fixing bacteria on the roots.

Mammoth red clover closely resembles red clover but is coarser in growth and requires from two to three weeks longer to mature. It can be grown on wet land better than the common red. It is a vigorous grower and a good collector of plant food in the subsoil. The yield is usually larger than the common red.

It is for the latter reason that mammoth clover is especially adapted for green manuring. The culture is essentially the same as for common red.

Alsike clover is especially adapted to low, level, moist clay land that is not particularly well drained. It will thrive when mammoth and red clover are killed by excessive moisture. Alsike clover is not so rank as mammoth clover nor is the root system so deep and extensive. As a green-manure crop it may be seeded directly after the preceding crop is harvested and can be plowed under the following spring, so that the land can be cropped every year.

Canadian field peas of some variety are usually grown for green manuring. They grow well even on the heaviest clays but do best on clay loams. On light soils deficient in moisture, they do not thrive. The crop grows best only in moist, cool weather, such as is common in northern climates during early spring and late fall and is, therefore, largely confined to the northern states. For green manuring the best method is to plant in the fall after the regular crop has been removed. The peas will make good growth in the fall and can be plowed under later the following spring, thus the regular cropping is not interfered with. Van Slyke says: "It has been shown that in two months it is possible to grow a crop of thirteen tons an acre with 120 pounds of nitrogen, 15 pounds of phosphorus and 100 pounds of potassium." Peas respond favorably to applications of phosphorus if the soil is in a rather run down condition. About three bushels per acre of seed is required.

Sweet clover is a biennial plant of rank growth and extensive root development. It grows on almost any kind of soil. It is hardy and

will grow and produce good crops where other legumes fail to produce a paying crop. It is for these reasons that sweet clover is especially adapted for building up soils that are "run down" in fertility. Not only does it gather and store large amounts of nitrogen from the air and leave the soil rich in organic matter through the decay of its extensive roots, but it is also valuable in that the soil by its growth will be inoculated with the same kind of bacteria that are required for alfalfa, making possible the successful growth of this valuable crop. Alfalfa today is grown successfully even in northern Minnesota, North Dakota and Canada where the soil is inoculated and other conditions favorable for its growth. Aside from its manurial value, therefore, sweet clover is very valuable as a forerunner for alfalfa.

Sweet clover is not valuable as a forage crop because of its bitter taste and rank coarse growth, unless it is cut when young and tender. For green manuring it should be seeded in the spring with rye or with an annual crop such as wheat. The crop is plowed under the following spring and the land used for a cultivated crop. Thus the soil is supplied with organic matter and nitrogen, and the regular crops are not interfered with. The growing of sweet clover is receiving much attention during recent years, particularly at the Ohio Experiment Station at Wooster.

Hairy vetch is considered by some authorities more hardy at low temperatures than any other leguminous crop used as green manure. As far north as New York it remains green all winter and resumes growth in the spring. Its hardiness makes it valuable for the north central states and Canada. It will not grow well unless the soil is previously inoculated with the species of bacteria living on its roots. It is not so deep rooted nor so vigorous of growth as some of the other legumes, and for these reasons it is not popular in the Northwest. It is seeded either in the spring with grain or in the fall during the latter part of August or September. Vetch responds favorably to applications of phosphorus and potassium.

Non-Leguminous Crops — The value of these as compared with the leguminous crops is so slight that they shall barely receive mention. As was previously stated, they do not gather nitrogen from the air. They are useful in late summer and fall where fields are left barren, to take up the plant food that is always being formed during warm weather. If there is not vegetation on such land during warm weather, the nitrogen will be lost by the leaching away of nitrates. Such quick-growing crops as buckwheat and rye take up these soluble compounds as they are formed and store them in the tissues of the plant. When plowed under the following spring, the plants are gradually decomposed and their nitrogen set free for the use of the crop planted that spring.

Useful in Orchards — Such crops when planted in orchards compete with the trees for plant food and moisture. It is a common occurrence in orchards to find that some trees make prolonged succulent growth of soft sappy wood together with undeveloped buds in the fall. Such trees are very sensitive to severe freezing, and to alternate thawing and freezing. The growth of green manure crops tends to induce growth of wood and earlier maturity because the crop uses up water and plant food that would otherwise tend to keep up the growth of the trees.

THE USE OF GREEN MANURES

While it is true that green manuring is instrumental in building up poor soils and that the physical condition is improved by the organic matter which is left in the soil, other methods can be followed to effect the same useful purpose. When conditions as have been indicated call for green manuring it is almost indispensable, but in live-stock farming other methods are more profitable. On farms where live stock is kept, and where legumes can be grown in the rotation to be fed to the stock and the manure returned to the soil, green manuring is not to be recommended. It is stated by several authorities that 80 per cent of all fertilizing constituents of materials fed to animals is voided by the animal in the form of solid and liquid excretions. We can readily understand that it is decidedly more profitable to feed the crops, otherwise intended for green manuring, to animals and get returns in the form of beef, milk and other animal products. It is only in sections where grain farming predominates, and where only a small amount of live stock is kept that green manuring is to be recommended as to the sole method of maintaining nitrogen and organic matter.

Soils Must be Limed — When a soil is well supplied with lime carbonate, the decay of organic matter and the manufacture of soluble plant food from it proceed more rapidly than under acid conditions. Since a rapid production of plant food during the growing season is desirable, the largest benefit from green manuring can only be expected when the soil is well limed.

The Treatment of Acid Soils — The sandy soils of the north central states are not well supplied with organic matter, hence green manuring is particularly profitable in such soils. Large areas of such soils are not so well adapted to live-stock farming on a large scale, hence the amounts of farm manure on hand is limited. Therefore, both for increasing the water-holding power, and for increasing the storing of nitrogen, green manuring with legumes is to be recommended. Such crops should be plowed under early enough so that good capillary connection can be established between the surface soil and the subsoil, and thus cutting off the supply of capillary water is avoided. Increasing the amount of organic matter in these coarse grained soils is a

much slower process than in the finer grained clay soils, but green manuring is, nevertheless, about the only method we have to follow. Farm manures are useful but their supply is limited, and then too, they suffer very rapid burning. The farmer on sandy soil must consider that the problem of supplying organic matter is an ever present one, for the rate of loss in such soils is much more rapid than in the finer grained soils.

Effects on Succeeding Crop—Extensive experiments have been carried on in different types of soil and under varying conditions to show the value of green manuring. Beneficial results have been very marked in many instances. Cultivated crops such as potatoes, corn and root crops are mostly benefited.

As to results from green manuring, Van Slyke has the following to say:

Red clover increased the yield of corn 20 bushels an acre, of oats 10 bushels or more, of potatoes 30 bushels; cowpeas, stubble and roots, increased the yield of sorghum 2 tons per acre and wheat 2 bushels for 4 years in succession; crimson clover increased the yield of potatoes 20 bushels an acre the first year and 27 bushels the second year. It is noticeable that the effect of legume green crop manures lasts through several seasons. Crops directly following green manures may sometimes be unfavorably affected. This will occur in a season when hot moist weather is prevalent and decomposition takes place rapidly. Then there will be large amounts of nitrogen liberated with the result of excessive growth of straw and unfilled grain with a tendency to lodge. The benefit to be expected from green manuring, will, of course, always depend upon the relative lack of nitrogen and humus in the soils where such crops are grown.

CHAPTER V.

COMMERCIAL FERTILIZERS

- I. WHEN THEY SHOULD BE USED. II. SELECTION OF FERTILIZERS—TABLE No. 14 COST OF NITROGEN IN DIFFERENT MATERIALS—TABLE No. 15 COST OF PHOSPHORUS IN DIFFERENT MATERIALS—TABLE No. 16 COST OF POTASSIUM IN DIFFERENT MATERIALS—TABLE No. 17 PRICES OF FERTILIZERS. III. DETERMINING NEED OF FERTILIZERS BY EXPERIMENTS. IV. THE USE OF COMMERCIAL FERTILIZERS AS PRESERVATIVES—TABLE No. 18 GAIN PER TON BY REINFORCING MANURE WITH COMMERCIAL FERTILIZERS.

WHEN THEY SHOULD BE USED

Under a good system of farming where live-stock is kept, and where an intelligent system of rotation is practised, where the products of the farm can be marketed in the form of beef or dairy products, and where some mill feeds are purchased and fed, the fertility of the soil can be maintained indefinitely; and the use of commercial fertilizers need or should not be resorted to.

Numerous experiments in various states have been conducted to ascertain how profitable commercial fertilizers are, in maintaining soil fertility. The results have been variable, depending, among other things, on the kind of crops and the fertility of the soil to which the fertilizers were applied.

In communities where conditions are favorable for intensive cultivation, and where sufficient nitrogen, phosphorus and potassium cannot be secured from farm manure or by green manuring, or in communities where special crop farming is practised, such as the growing of potatoes, mangels or beets, large amounts of certain elements are utilized by the crop which is sold from the farm. In such cases, intelligent use of commercial fertilizers to replace the exhausted element is indeed often profitable.

The farmer intending to buy fertilizers must first of all satisfy himself that the nitrogen, phosphorus and potassium cannot be supplied through the manurial resources of the farm. He must know what elements are deficient in the soil. These he can determine by observing the behavior of crop growth on the land, by having a knowledge of crops previously grown, and by trying out the various fertilizers in small plots on the farm. If the increased yield is sufficient to cover initial cost of fertilizers, cost of hauling to the farm, spreading, and interest on investment, then commercial fertilizers can be used to advantage. He must select

his fertilizer according to the needs of his soil and the crop he wishes to raise. Then the question arises — what fertilizer is the most profitable to use?

SELECTION OF FERTILIZERS

It is a deplorable fact that farmers often purchase fertilizers blindly not knowing the efficiency of the fertilizer nor even knowing if one is needed at all. Millions of dollars have thus been spent by American farmers without any adequate return.

There are on the market today numerous brands and mixtures of commercial fertilizers. These are the most expensive forms in which to purchase plant food. Results of an investigation by Van Slyke of the New York Experiment Station show that "when nitrogen could be purchased by farmers at 14 cents a pound, the nitrogen in mixed fertilizers was costing over 20 cents a pound on an average, and in the grades of fertilizers finding most extensive sale, the cost varied between 18 and 36 cents. Similar disproportions were found in the case of phosphorus and potassium."

The most economical method of securing the necessary plant food is to buy the individual constituents which make up the "compound fertilizers" and apply them according to the needs of the crops and soil.

TABLE No. 14
RETAIL COST OF NITROGEN IN DIFFERENT MATERIALS

Material (commercial product)	Retail price per ton	Percentage of nitrogen	Pounds of nitrogen in 1 ton	Cost of 1 pound of nitrogen
Sodium nitrate*.....	\$54.25	15.20	304	17.8 cents
Ammonium sulphate.....	66.00	20.60	412	14.6 cents
Dried blood*.....	50.78	10.75	215	21.6 cents
Calcium cyanamide.....	53.00	18.00	360	14.7 cents

*Bulletin 392—N. Y. Experiment Station (Geneva).

TABLE No. 15
COST OF PHOSPHORUS IN DIFFERENT MATERIALS

Materials	Retail price per ton	Per cent. of phosphorus	Pounds phos- phorus in 1 ton	Cost of 1 pound of phosphorus
Acid-phosphate.....	\$14.50	5.03	101.6	14.2 cents
Bone meal.....	36.60	10.17	203.4	18.0 cents
Basic slag.....	18.50	7.80	156.0	11.8 cents
Ground rock phosphate.....	8.50	13.74	274.8	3.1 cents

The acid phosphate is in an easily available form. Bone meal and basic slag are less soluble, but both readily become available under soil conditions. Ground rock phosphate is the cheapest source of phosphorus as will be noted from a consideration of the last column in the above table, but it is only slowly available. Where it can be incorporated with a green manure crop, or with farm manure, the decay of the organic matter helps make the rock phosphate available. Where quick

returns are desired the more soluble phosphates should be purchased, such as acid phosphate. The prices quoted above for the first three forms of phosphorus fertilizers are average selling prices in the state of New York in 1914. The rock phosphate costs \$13.00 per ton in New York but is being sold in the north central states as low as \$6.25 per ton in bulk in carload lots, this price including the freight.

TABLE No. 16
COST OF POTASSIUM IN DIFFERENT MATERIALS

Materials	Retail price per ton	Percentage of potassium	Pounds of potassium in 1 ton	Cost of 1 pound of potassium
Muriate potash.....	\$46.95	49.80	996.0	4.7 cents
Potassium sulphate.....	56.50	50.17	1003.0	5.6 cents
Kainit.....	13.93	13.00	260.0	5.3 cents
Wood ashes.....	27.00	3.27	65.4	41.3 cents

The prices quoted above are the average prices for 27 samples of muriate, 5 samples of sulphate, and 11 samples of kainit as offered for sale to the farmers of New York during the year 1914. The prices quoted for wood ashes are so high that it is the most expensive form of potassium. If, however, wood ashes containing about 5% potassium can be bought for about \$10.00 per ton, making the cost per pound of potassium about 10 cents, then wood ashes become a profitable fertilizing material. Wood ashes also contain a large amount of lime carbonate so that they are useful material for correcting soil acidity. Leached ashes are still higher in lime carbonate for the potassium carbonate has largely been leached away.

TABLE No. 17
PRICES F. O. B. OF COMMON FERTILIZERS IN THE WEST

For what purchased	Fertilizer	Percentage of plant food	Price, per ton
Nitrogen.....	Sodium nitrate	15.25 nitrogen	\$65.00
Phosphorus.....	Acid phosphate	7.3 phosphorus	16.00
Potassium.....	Potassium chloride	41.5 potassium	50.00

It will be seen by comparing that these are considerably above New York prices. Co-operation in buying so that large quantities may be ordered, will lead to lower prices to the farmer.

DETERMINING NEED OF FERTILIZERS BY EXPERIMENT

At one time the Northern Pacific Railroad Company conducted a number of plot experimental farms all along their lines in Minnesota and eastern North Dakota, in order to ascertain if nitrogen, phosphorus or potassium were lacking in soils of these districts and if so, could it be profitably supplied in the form of commercial fertilizers. To supply nitrogen, sodium nitrate was bought; for phosphorus, acid phosphate, and for potassium, potassium chloride. The plots were established on the

average soil of the district and the experiments were conducted in co-operation with the progressive farmers in the neighborhood.

What the Experiment Showed — Although larger yields were secured in most cases they found that the nitrogen fertilizers at the price could not be profitably supplied, and that many of the soils contained an abundance of nitrogen but not in available form.

Assuming that not all of the phosphorus was utilized by the crop and that some of the succeeding crop would be benefited by what remained, the increase in yield was slightly more than the cost of fertilizers for that element.

Potassium was found abundant in most places except in some sand and peat soil and its application was not generally profitable.

Use as Preservatives — From the tables of composition and from the text in Chapter III, "The Application of Farm Manure," it will be remembered that the liquid contains the most soluble and valuable portion of the manure.

Experiments at the Ohio Station covering several years have shown that for their type of soil, at least, a profitable increase in crop yield is secured by reinforcing the manure with rock phosphate, acid phosphate, gypsum and kainit, at the rate of 40 pounds per ton of manure.

In these experiments acid phosphate gave the greatest net return. Ground rock phosphate gave nearly as high returns while at the same time it enriched the soil with more phosphorus than acid phosphate. The net increase per ton of manure and absorbents was as follows:

TABLE No. 18
GAIN PER TON BY REINFORCING MANURE WITH COMMERCIAL FERTILIZERS

Acid-phosphate	Ground rock phosphate	Gypsum	Kainit	Stable manure (clean)
\$4.82	\$4.49	\$3.56	\$3.71	\$3.31

We do not wish to condemn commercial fertilizers. On some soils and under certain conditions their use has been rewarded with gratifying results. It must be remembered, however, that by the constant use of commercial fertilizers alone the organic matter of the soil is depleted. We must raise live stock, feed the grain and forage to the stock, plow under an occasional crop of green manure, and probably supplement from time to time with some form of phosphate if the permanent productivity of our soil is to be maintained.

CHAPTER VI

CONTROL OF GENERAL SOIL CONDITIONS

I. CONSERVING MOISTURE OF SOILS—VALUE OF ORGANIC MATTER—TABLE NO. 19 POWER OF SOILS TO HOLD WATER—TABLE NO. 20 SNYDER'S EXPERIMENT—EFFECT OF CULTIVATION ON MOISTURE CONSERVATION—TABLE NO. 21 EFFECTIVENESS OF DIFFERENT DEPTHS OF CULTIVATION. II. CONTROL OF SOIL BLOWING. III. WASHING OF SOILS.

CONSERVING MOISTURE OF SOILS

Moisture is perhaps the most variable factor in crop production. Even in sections of the country where there is sufficient rainfall for maximum crop production, fields often fail to produce a normal crop, due to improper handling and conserving of the moisture which exists in the soil. It is essential, therefore, that we consider some of the simple and practical ways whereby this important factor in crop production can best be conserved and utilized.

Proper cultivation is one way of reducing the loss of soil moisture. Cultivation furnishes a "dust blanket," as it is sometimes called, which is a loose top layer of surface soil. This serves two purposes: it enables the soil to hold moisture from rains more effectively and in greater amounts and it prevents evaporation after reaching the soil. The fact is well established and generally known that if the surface soil is left undisturbed, the soil particles are in such close contact that moisture from the subsoil passes directly to the surface and is lost by evaporation. If on the other hand a loose mulch is kept on the surface, the subsoil moisture ceases to rise when the loose earth is reached, remaining at that point ready for the direct use of the plants.

Value of Organic Matter — Extensive experiments at various experiment stations have demonstrated that humus or organic matter in the soil is of great value in protecting the crop from drying up during the summer ("summer fring"). Of two adjoining fields, one was well supplied with plant food but left with a low percentage of humus; the other well supplied with humus through applications of farm manure, peat or green manures. The crop growing on the soil containing the organic matter showed no ill effects during hot windy days of summer or during periods of drought; while on the other soil, corn, especially, was noticeably "fired" and failed to develop a normal crop.

Soils vary greatly in their powers to absorb and hold moisture; this has been demonstrated by laboratory experiments at the Michigan Experiment Station.

TABLE No. 19
POWER OF SOILS TO HOLD MOISTURE

Soil	Percentage of water retained
Clay.....	56
Loam.....	49
Sandy Soil.....	36
Air-dry Peat.....	170

Snyder's Experiment—The following by Snyder shows the same general water-holding power. The new soil contains 265 tons of water per acre-foot of soil, while that of the old soil contains only 180 tons per acre-foot.

TABLE No. 20
EFFECT OF EXHAUSTIVE CROPPING ON WATER-HOLDING POWER OF SOILS

	New soil cultivated 2 years	Old soil cultivated 22 years
Humus.....	3.75 per cent	2.50 per cent
Water.....	16.48 per cent	12.14 per cent

The value of organic matter in the retention of soil moisture can therefore not be over-emphasized. The organic matter not only holds the rain which falls, thus preserving it for future plant growth, but it also lessens the rate of loss by evaporation at the surface.

Effect of Cultivation on Moisture Conservation—It is generally concluded that soils containing a large amount of humus show less marked benefit by frequent and thorough cultivation than soils low in this constituent. Ordinarily the moisture retained by cultivation, especially after heavy rains, is sufficient to justify frequent cultivation. The depth of cultivation influences the moisture content of soil as is shown by the following from the Michigan Experiment Station.

TABLE No. 21
EFFECTIVENESS OF DIFFERENT DEPTHS OF A SINGLE CULTIVATION
DURING A PERIOD OF 21 DAYS

Depth of cultivation	Loss of water in tons per acre per day	Loss in inches	Per cent moisture saved
0 inches	10.4	1 inch 10 days	0.00
1 inch	5.19	1 inch 21 days	0.6
2 inches	3.36	1 inch 33 days	67.7
3 inches	3.16	1 inch 35 days	69.6
4 inches	2.86	1 inch 39 days	72.5

Another common and very effective method of adding moisture to the soil is by fall plowing. This is especially beneficial in regions of scanty rainfall. The fall rains are thus held in the soil. The rough, uneven surface of the plowed field catches the snow and holds it, and this when melted adds considerable to the moisture supply of the soil.

CONTROL OF SOIL BLOWING

There are in general, two distinct damages done by the blowing of soils: first, the injury to crops growing on such soils, and second, to the soil itself. It is a common occurrence in arid or semi-arid districts, and even in the northern states for farmers to lose a large portion of their crops after a period of drought or during prevailing high winds. This is due to the erosion or grinding of the grains of sand carried by the wind. The seed is often exposed and blown away; the plants are materially injured by the moving soils; and large portions of the fields are buried under several inches of soil through which the plants cannot penetrate. The upper portion of the soil contains most of the soluble forms of plant food. This is the portion carried away by high winds leaving the soil unfit for plant growth and consequently barren. The extent of blowing depends on the kind of soil, its organic and moisture content, the degree of exposure and the velocity of wind. Sandy soils are especially liable to be damaged by blowing. This is due principally to the fact that sand is less cohesive than other soils, and to a deficiency or lack of moisture. On such soils one of the best methods of control is the laying out of narrow "plow lands" at right angles to the direction of the prevailing winds, and having cultivated crops and grain or grass crops on alternate strips. Clay soils are less subject to erosion because they are adhesive in character.

Blowing can be largely checked by the addition of organic matter. As has been previously stated, humus makes the soil more cohesive and holds moisture in the soil. The value, therefore, of adding organic matter to soils subject to blowing cannot be too greatly emphasized. It is a well known fact that soils subject to erosion can be largely controlled by vegetation. A good growth of grass prevents the wind from coming in direct contact with the soil. For this reason it has become a common and successful practice to seed down land subject to blowing, to permanent pastures or meadows, and to devote such areas to grazing rather than grain farming.

However, on many farms only portions of the fields are subject to blowing. The blowing can be largely controlled on such areas by leaving the stubble of the last crop standing until the land is prepared for a crop the spring following. The damage by plowing will be slight if the crop is put in early while the soil is in a moist condition. If the soil is reasonably fertile the crop will soon become well established and the blowing consequently checked.

If for the purpose of eradicating weeds, or for some other reason, the soil is cultivated, the surface should be roughened. This keeps the particles from blowing because the depressions in the soil protect them from exposure.

On small areas, straw is sometimes spread over the field to prevent

blowing. The straw checks the velocity of the wind on the surface of the ground. Straw also catches and holds moving soil particles.

WASHING OF SOILS

It is not uncommon on rolling land after very prolonged or heavy rainfall, to see large tracts of hillside that are badly injured or ruined by surface washing. The water in obedience to the force of gravity, tends to flow in the "draws." This accumulation of water gives it great volume. The resistance is slight, giving the water great velocity. Large amounts of soil particles in suspension and particles moving on the bottom, together with the velocity and the volume of the water, will in a comparatively short time form deep gullies, which are enlarged by each subsequent rainfall and soon are beyond repair.

The presence of organic matter is beneficial in two ways; it binds the soil particles together, and makes the soil more porous, often thus holding a large amount of the water that would otherwise be carried away.

A blanket of vegetation is the surest check to washing. A good growth of grass will utilize a large amount of water; roots will form a perfect network in the soil and thus hold the soil particles; and the vegetation, or growth at the surface, tends to check the movement of water and soil particles at the surface. Seeding down hilly districts, especially the gullies and ravines, to permanent pastures, rather than cultivating them, is therefore recommended by most authorities.

The government has reclaimed large portions of hilly lands that have proved useless for cultivation, grazing or for meadows, by planting forest trees. Such regions, having had a heavy growth of forest, have become absolutely worthless when cleared for agricultural purposes.

Stones, brush or straw thrown into water channels check the velocity of the water and thus largely reduce erosion. Plowing at right angles to the slope of the land is recommended by some authorities. This is practical and effective on land where the general slope is only in one direction. Although this method of preventing washing may be impracticable where land is hilly and the contour irregular, yet when it is the only means of preventing erosion, we find it is becoming a highly recommended practice, especially in the southern states. Many farms in the hilly regions of the north central states might well have their whole system of fields replanned so as to make possible this contour plowing.

BOOK IV

THE GARDEN AND THE ORCHARD

THE GARDEN AND THE ORCHARD

CHAPTER I.

THE FARM VEGETABLE GARDEN

- I. LOCATION. II. SOIL. III. CULTIVATION AND TOOLS. IV. THE HOTBED. V. PLANNING THE GARDEN. VI. SELECTION OF VARIETIES. VII. SOWING SEED. VIII. CONTROLLING WEEDS. IX. STORING. X. CANNING VEGETABLES. XI. INSECTS AND FUNGUS ENEMIES. XII. CLASSIFICATION OF CROPS—ROOT CROPS—COLE CROPS—FOLIAGE CROPS—SOLANACEOUS CROPS—THE LEGUMES—VINE CROPS—PERENNIAL VEGETABLES. XIII. QUANTITY OF SEED REQUIRED.

The garden although greatly neglected in the past is one of the most valuable assets of the farm. In it may be grown a wide variety of vegetables, herbs and small fruits. These crops provide a supply of fresh food of highest quality which is much appreciated by the family. Then, too, the monetary value of the garden is high. A half acre devoted to vegetables will easily yield an amount of food equivalent to one hundred dollars worth or more of vegetables and meat bought on the market. In planting the garden one should aim to have a constant and uniform supply of the vegetables preferred by the family. They should be of the highest quality and should be so grown as to require little hand labor.

The Location—The garden should be located close to the house. This is desirable because most of the harvesting is done by the housewife and because care of the garden has to be given generally in odd hours. A garden located some distance from the house is therefore much more likely to be neglected.

A southern or southeastern exposure is preferable because the soil is ready for planting earlier in the spring. A windbreak of boards or trees on the northern or western side will often cause the soil to warm up much earlier in the spring than when it is left exposed to the cold winds. The shade of trees or buildings should be avoided as much as possible.

The land should have good natural drainage but be retentive of moisture. A supply of water close at hand is often of great value in transplanting and in watering crops during dry periods. If enough land is available it is advisable to change the location of the garden every year or two as continued cropping is likely to exhaust the plant food and greatly increase the danger of injury from insects and plant diseases. If this is not possible then the plan of the garden should be changed from year to year so that the crops will be grown in different locations.

The Soil—The ideal soil is a sandy loam which contains a large amount of decaying vegetable matter. A clay or clay loam soil is too heavy for best results. If it is the only soil available it can be greatly improved by the addition of a large amount of well rotted manure. The soil should preferably have produced a cultivated crop the season previous to being used for garden purposes. It may be plowed either in the spring or fall. If a clover or timothy sod is used, it should be plowed in the fall so that the sod may decay before planting time.

Manure is the most important fertilizer for the garden and is extensively used on all kinds of garden soil. A large supply of humus in the soil is absolutely necessary for the production of garden crops and manure is the best source of this material. Manure increases the water-holding capacity and loosens and aerates the soil, thus improving its texture and lessening the labor of cultivation. It is superior to green manures because it decays much faster and does not sour the soil to so great an extent. It is an excellent source of plant food, particularly nitrogen, which is required in large amounts by vegetables. The commercial value of the plant food contained in manure varies from about \$2.00 per ton for cow manure to \$7.00 for that from the chicken house. The methods of storing the manure will also affect its value, leached or fire-fanged manure being much less valuable than when it is properly preserved. Manure may be applied to garden soils at the rate of twenty-five to thirty tons per acre. It should preferably be plowed under unless well rotted, when it may be used as a top dressing and disked into the soil.

Commercial fertilizers may be used to supply a known deficiency of a certain element. Thus on muck soils which are very deficient in potash, a potash supplying fertilizer should be used to supplement the manure. Manure is an unbalanced ration containing too large a proportion of nitrogen to be most economical when used alone. Commercial fertilizers rich in phosphoric acid and potash may be used to balance the excess of nitrogen. Some commercial fertilizers are much more quickly available for the use of the plants than is manure. As high quality in vegetables is usually obtained by rapid, succulent growth, especially with such crops as cabbage, lettuce and radishes, the gardener can often obtain much better results if he uses liberal amounts of readily available commercial fertilizers.

Of the different fertilizing elements nitrogen is most important in vegetative production and is therefore used extensively with crops which are not grown for seeds or fruits, as cabbage, lettuce, chard or celery. Nitrate of soda and dried blood are the most common forms of commercial fertilizers used for supplying this element. The former is more readily available. It may be applied at the rate of 150 pounds per acre sown broadcast or distributed along the rows. Phosphoric

acid hastens maturity in vegetable crops. It is sold as rock phosphate or acid phosphate. Potash increases the growth of root crops and is particularly important on muck or sandy soils. Continued use of commercial fertilizers or the turning under of green manuring crops is likely to make the soil acid. Lime may be used to correct soil acidity. An application of 500 pounds per acre of hydrated lime once in four years should keep the average soil in good condition as regards acidity.

Tools and Cultivation—One of the most important operations in the garden is proper tillage. Cultivation loosens the soil, aerates it, conserves the moisture and kills weeds. Successful cultivation depends upon timeliness and thoroughness. Good plowing and thorough harrowing and disking will save many weary hours of hand labor later on.

The depth of plowing will depend somewhat on the crops to be grown. For root crops the soil will need to be broken up deeper than for those crops with shallow root system. The character of the soil is also a controlling factor in depth of plowing, heavy soils requiring deeper plowing for good results than those which are more porous and open. With small gardens spading will take the place of plowing.

After plowing comes disking. With the heavier types of soil it is usually advisable to disk at least three times and then follow with the smoothing harrow. Cultivation should continue until the soil is fine and friable, as it is only when it is in this condition that satisfactory results are to be expected.

The crop should be cultivated after each rain and at least once every ten days until it gets so large that cultivation is impossible. Thorough cultivation is necessary to conserve the soil moisture and to make enough plant food available for the steady growth of the crop.

The tools necessary for garden cultivation depends upon the size of the garden and whether cultivation is to be done mostly by hand or by horse power. In the larger garden the following are among the most important tools: plow, disk harrow, smoothing harrow, horse cultivator, hand wheel cultivator, row marker, hand seed-drill, hoes, trowels, dibbers and spades.

The Hotbed—The early or long season crops such as head lettuce, early cabbage, early celery, tomatoes, peppers and egg plant should be started under glass. The hotbed and cold-frame are the most important structures used for this purpose. Kitchen windows are often utilized to start plants for a small garden, but are rather unsatisfactory because the plants are usually spindling and tender and are not properly hardened off before they are set in the field. As a result such plants rarely do well. The kitchen window or the hotbed may be used to grow the plants for four or five weeks after which they may be set in the cold-frame to harden off before being set in the field.

The difference between the hotbed and the cold-frame is that the

hotbed is supplied with artificial heat, usually secured from fermenting manure, while the cold-frame gets all its heat from the sun. The hotbed should be located on the southeastern side of a building or a southern exposure so as to get the full benefit of the sun's rays and should be protected from the north and west winds. The site should be well drained and near a supply of water. The frames are usually made to accommodate either three or four sash, the common size being 6x12 feet which would require four sash. They should be made of durable wood and if to be used for several seasons should be so constructed as to be easily taken down and set up. A convenient method of holding the pieces of the frame together while in use is to attach two wagon-box irons to each end of the side pieces, having holes in the end pieces so located as to fit over the ends of the wagon-box irons. The frame should extend 12 inches above the surface of the soil on the north side and 6 inches on the south side. A 2x3 inch cross-piece should be mortised into the side pieces at the point where the two sash come together to help support the sash and keep them from warping. These cross-pieces are also convenient when cultivating or weeding the bed.

There are two types of hotbeds: the pit and the surface. The latter is set on top of the ground and requires much more heating material and is usually less satisfactory. For a pit hotbed the pit should be about 24 inches deep. It should be dug in the fall before the ground freezes and should be lined with boards or, if it is to be permanent, with cement. It is a good plan to fill the pit with loose litter, but if there is not enough available to fill it, the bottom should at least be covered to keep out the frost.

The time for starting the hotbed will depend upon the region and the plants to be grown. The best material for filling the pit is fresh horse manure from grain-fed animals. It should contain from one fourth to one third litter and should have been kept from leaching or fire-fanging. Manure containing shavings is unsatisfactory as a rule, it heats too rapidly and does not retain its heating qualities long enough. To start heating, the manure should be placed in a pile about five feet high, with straight sides. In about four days, if conditions are favorable, heating will have started and the interior of the pile become quite hot. It should then be turned, the outside of the pile being thrown into the interior, and the whole mass packed down fairly firm. If it is slow to start heating, sprinkle the pile with hot water which will usually hasten the fermentation.

When heating evenly the manure is ready for the pit. It should be packed firmly as it is put in, special care being taken to have the edges somewhat firmer than the center. After the desired amount of manure has been put in, about four inches of good garden soil should be put on when plants are to be grown for transplanting. The temper-

ature of the soil will rise considerably above that which is desirable for germination, it is therefore best to wait a few days until the temperature has fallen to 85 or 90 degrees F. before sowing seed. Under ordinary conditions it takes from twelve to fifteen days from the time the manure is secured until the bed is ready for sowing.

The soil to be used in the hotbed should be secured in the fall and stored so as to prevent freezing. If the soil is a heavy loam or a clay loam, it is improved for hotbed purposes by the addition of sand or mixing in some well-rotted manure. A very satisfactory formula for this type of soil is two parts garden soil, two parts rotted manure, one part sand. The soil should be thoroughly mixed and it is a good plan to run it through a screen before putting it in the bed. It should be fairly moist when put in the bed. Squeeze the soil in the hand and if it retains the imprint of the fingers without crumbling, but breaks up easily when jarred, then the water content is practically ideal.

The seed is usually sown in drills about two inches apart, and about eight to ten seeds to the inch. After the plants get their first true leaves they are transplanted. Cabbage and lettuce are set one and one-half by one and one-half inches, while tomatoes and egg plants are set two by two inches. The hotbed should be watered when the plants require it, but only on bright mornings when the temperature is rising so that the surface of the soil and the leaves of the plant may become dry before night. Water thoroughly. This will mean putting on enough water to saturate most of the soil, and then waiting until the lighter color of the soil indicates that water is needed again. Watering which merely wets the surface of the soil is frequently more injurious than beneficial.

Ventilation is absolutely necessary — It is accomplished by raising the tops of alternate sash an inch or two. Careful watering and daily ventilation keeps the plants from getting spindly and tends to prevent the development of damping-off fungus which is the most serious trouble of the hotbed. On cold nights and wet, snowy days the hotbeds should be covered with mats, made of rye straw or burlap, to conserve the heat. When mats are not available old comforts or pieces of carpet will serve the purpose quite as well.

Planning the Garden — Many failures in the home garden result from poorly thought-out plans. The plan should be carefully studied, drawn out, if possible, to scale and then strictly followed. Plans of gardens will vary with the individual's tastes and the conditions under which he works. On a city lot the garden must assume the shape of the available ground, but the farmer will have greater freedom and may plan his garden so as to reduce the amount of hand labor necessary to care for it. Where sufficient land is obtainable the rows should be placed about thirty inches apart so as to permit horse cultivation. They should preferably run the long way of the field with the perennial vegetable

as rhubarb, asparagus and horseradish located at one side of the garden where they will not interfere with the cultivation. The long season crops and the short season crops should be grouped separately so as to facilitate planting and cultivation and to give a chance for succession cropping.

Selection of Varieties — The seed used in the garden should be of the best and of a variety

which is adapted to the soil and climate of the place where the garden is to be located. Seed may be saved at home, but it is usually just as cheap and more satisfactory to buy it of a reliable seed firm. It is better to select standard varieties of known quality and productiveness than novelties which the seed man booms but whose value has not been proved.

In selecting varieties we should always choose those of highest quality rather than those of greatest productivity. Golden Bantam sweet corn, for example, is so far superior to ordinary kinds that it should be the principal variety planted in the farmer's garden, although it may not yield so much as some of the coarser kinds. The varieties should also be selected with the object of cover-

	HOTBED
	COLD FRAME
LETTUCE PROVED UP ON GNS.	
CARROT SEEDS SOWN AT 12 CHORS	
THAT HAVE GROWN IN PINCH HOWS.	
	WALK
EARLY PEAS AND BEANS (FOLLOWED BY CELERY)	
EARLY PEAS AND BEANS (FOLLOWED BY CELERY)	
PEAS (FOLLOWED BY SPINACH).	
PEAS (FOLLOWED BY SPINACH)	
EARLY CABBAGE (FOLLOWED BY LATE PEAS)	
EARLY CABBAGE (FOLLOWED BY LATE PEAS)	
TOMATOES	
TOMATOES	
TOMATOES	
CUCUMBERS	
CUCUMBERS	
CUCUMBERS	
MUSKMELONS	
MUSKMELONS	
EARLY POTATOES (FOLLOWED BY LATE CABBAGE)	
EARLY POTATOES (FOLLOWED BY LATE CABBAGE)	
EARLY CORN (FOLLOWED BY TURNIPS)	
EARLY CORN (FOLLOWED BY TURNIPS)	
EARLY CORN (FOLLOWED BY TURNIPS)	
EARLY CORN (FOLLOWED BY TURNIPS)	
	RHUBARB AND HERBS.

Fig. 1.—Garden Plot 50x90 Feet.
 Courtesy of the United States Department of Agriculture

ing the entire season or as much of it as possible. This is especially true of tomatoes, cabbage, beans, peas and radishes. Some varieties which are entirely worthless from the commercial point of view, as red currant and yellow pear tomatoes, may be very desirable in the home garden.

Sowing Seeds — The germination of viable seed is dependent upon

proper conditions of moisture, heat and air. These are directly dependent upon the condition of the soil and may be materially influenced by its preparation. Frequently on heavy soils which lack humus or are poorly drained, sufficient air is not available for germination and a poor stand of plants results. Large clods or lumps of earth cause the soil to dry out rapidly and the seed, having poor contact with the soil, is unable to absorb sufficient moisture to enable it to start growth. A fine soil which has been made loose and friable by thorough tillage and the liberal use of well-rotted manure is necessary for best results. In such a soil practically the entire surface of the seed is in contact with the earth, which enables the seed to get sufficient moisture, and, if other conditions are favorable, insures satisfactory germination.

The time of planting depends upon the hardiness of the crop grown, and the time at which it is to mature. Lettuce, onions, beets, cabbage, cauliflower, peas, and radishes may be sown as early in the spring as the ground is fit to work, because the seed will germinate at a relatively low temperature and the crops are not injured by frost as readily as some of the other vegetables. Tomatoes, egg plant, pepper, beans, muskmelons, and cucumbers require a much higher temperature. The seed will rot in cold, damp soil and the plants cannot stand low temperature and must not be planted until danger of frost is past. A succession of such crops as cabbage, lettuce, peas, beans, and radishes may be obtained by making plantings at intervals of two to three weeks.

The depth of planting varies with the type of soil and with the requirements of the crop. Seeds may always be planted deeper in a light soil than in a heavy one. Such seeds as peas and corn will push their way through an amount of soil which would prevent the germination of parsnips or celery. Plants with fibrous root systems are easily transplanted, no difficulty will be encountered in transplanting cabbage, tomatoes, lettuce, egg plant and many other vegetables. On the other hand, peas, beans, corn, radishes, turnips and also the cucurbits (cucumbers, melons, squash, etc.), are not easily transplanted because few fibrous roots remain on the plant after it has been removed from the soil. Cucumbers, melons and other plants which often do much better



Fig. 2.—The Garden Drill.

Courtesy of the Minnesota Experiment Station

by being started before they can be planted in their permanent location, should be planted in berry boxes, paper pots or other receptacles from which they may be removed and transplanted without disturbing the root system seriously. Even tomatoes and cabbage which transplant readily are best handled in this way when grown for an early crop because they receive practically no check when transplanted.

The seed-bed should be well watered before pulling the plants for transplanting and a large lump of earth should be left clinging to the roots. Transplanting is best done on a dark, cloudy day, in late afternoon, or just before or after a rather light shower. Usually so large a portion of the root system is destroyed in pulling the plant, that those remaining cannot supply enough moisture to keep the plant from wilting, unless the transpiring area is reduced. In most cases it is, therefore, necessary to remove at least half of the leaves to reduce transpiration. This is especially important in dry or sunshiny weather. Plants should be set a little deeper than they were in the seed-bed. Leggy or spindling plants should be placed in the soil up to the first leaves and in the case of tomatoes to within three inches of the top of the plant. Setting the plants deep is often an advantage because it permits the development of a larger root system.

Usually crops grown from seed without transplanting must be thinned. This is particularly true of root crops—radishes, onions, beets, carrots, etc., and to a lesser degree of lettuce, beans, peas, cucumbers, corn and spinach. The individual plant must have enough room to develop properly. The distance to which they are thinned varies with the individual crop and with root crops depends on whether they are to be grown to maturity or not. The distances range from two inches in the case of radish to eight or ten inches with sweet corn. Thinning is a process of selection, the weakest plants should be pulled out and only the strongest allowed to mature.

Controlling Weeds—Perhaps the greatest drawback to the old-fashioned enclosed garden was the problem of weed control. The weed problem is the greatest argument in favor of the horse-cultivated garden. The following methods will be found helpful in controlling weeds:

1. Crop rotation. Many weeds which thrive year after year on cultivated fields will be crowded out if the field is sown to clover.

2. Thorough preparation of the soil. Weed seeds and the roots of biennial or perennial plants will be smothered much quicker when the plowing and harrowing have been done thoroughly.

3. Cultivation. Cultivation when the weed seeds are germinating and before the weeds have developed large root systems is much more efficient than cultivation done after the plant has become well established. When slow germinating vegetables, as carrots and parsnips are grown, cultivation can be begun much sooner if a few quick germinating seeds like radish seed are scattered in the row.

Storing—By proper methods of storage the season in which fresh vegetables may be had can be prolonged until those of the following season

are available. A vegetable cellar or storage pit is one of the most important adjuncts of the farmer's garden. Low temperature, moist atmosphere and ventilation are the essentials for the successful storage of most vegetables. Cold storage is usually not necessary and often undesirable for keeping vegetables over winter. The requirements of light, temperature, moisture and ventilation vary for the different vegetables, but a temperature of 35 to 40 degrees F., accompanied by a moist atmosphere, gives the right combination for a majority of the crops which are likely to be stored. Such conditions may be had in a dark cellar with a dirt or concrete floor, shut off from the heating system of the house. If the vegetables are not put into storage too early the temperature can be controlled with comparative ease. Maintaining the proper atmospheric moisture is somewhat more difficult. Placing pails of water in the cellar, or sprinkling the floor if necessary, will assist in keeping the moisture right.

Beets, carrots and other root crops are often stored in pits. A well-drained spot is selected and the vegetables placed in a conical pile and then covered with clean, dry straw and five or six inches of soil. If desired, additional protection may be given when severe freezing takes place. Salsify and parsnips may be left in the garden over winter. Freezing improves the flavor of these vegetables and contrary to popular opinion they are not poisonous the second season.

Leaf crops such as cabbage and celery should be kept at a low temperature, 32 to 36 degrees, in a fairly moist but well-ventilated atmosphere. If ventilation is neglected decay will set in and cause considerable loss. These crops should not be allowed to freeze and thaw, as alternate freezing and thawing breaks down the tissues and causes decay.

Pumpkins, squashes and sweet potatoes should be stored in a dry, well-ventilated atmosphere, at a temperature of 50 to 60 degrees. Sweet potatoes are allowed to go through a sweating process for two or three weeks after harvest and are then placed in dark, frost-proof bins. Onions require a dry atmosphere and low temperature, but the presence or absence of light makes no difference. They may be stored in a frozen condition, but must be used as soon as they are thawed, as they go down very quickly after thawing. Alternate freezing and thawing must be prevented.

Some crops may be improved by growing in storage. Among them may be mentioned unblanched celery, leeks, Brussels sprouts and parsley. The conditions under which such crops are kept are as follows:

1. Plant the roots in soil or sand.
2. Keep the roots moist and the tops dry.
3. Keep the temperature low.
4. Keep the air circulating freely about the tops to prevent decay.

The bitter taste of unblanched celery or leeks may be removed by the above methods. Celery blanched in storage keeps from one to two months longer than when blanched before putting in storage.

Vegetables intended for winter use should reach the proper stage of maturity at the time they are to be put in storage. For most vegetables this

is shortly before they have attained their maximum size. Many vegetables are spoiled if they are allowed to develop too much. Cabbage if planted too early will get over-ripe and very often the heads will burst. Turnips rutabagas or beets will become woody and unsuited for food if allowed to develop fully.

Canning Vegetables — Some vegetables are preserved for winter use by canning. Those commonly preserved by this method are rhubarb, tomatoes, corn, peas and string beans. The operations of canning are not particularly difficult. The first requisite of successful canning is sterilized receptacles which may be sealed air-tight. The second requisite is thorough sterilization of the vegetable. The ease with which this may be done differs with different vegetables. In some instances it is a simple process, but with others it may be necessary to bring the vegetable to the boiling point several times covering a period of several days before thorough sterilization is accomplished. Beans and peas are among those most difficult to can successfully.

Insects and Fungous Enemies — The garden will always be attacked by various insects and diseases. It is better to prevent these pests getting a foothold than to try to eradicate them after they have become established. This is particularly true of diseases. Methods of fighting diseases are, therefore, largely methods of sanitation and prevention. In the control of fungous diseases the following principles should be kept in mind: (1) Keep the seed-bed free from disease. Many diseases as club-root and black rot of cabbage and damping-off of young plants attack the plants in the seed-bed. In selecting the site for a seed-bed care should be exercised to secure one which is free from these troubles or to sterilize the soil either with steam or formalin before sowing seed. (2) Disinfect all seed likely to contain disease germs. Potatoes should be treated with corrosive sublimate or formalin for scab as should cabbage seed for black rot. (3) Rotate crops. Potato scab, lettuce drop, club-root of cabbage and many other diseases live in the soil for several years after infestation. They can usually be eliminated by growing crops of a different nature on the soil for two or three years. (4) Select disease-free seed. Anthracnose of beans, scab and late blight of potatoes as well as many other diseases are carried over on the seed. (5) Spray the plant with the proper standard fungicide or insecticide if pests are present or conditions favor their development. Early blight of potato, musk melon blight and other leaf-attacking fungi may be prevented from gaining a foothold by proper spraying before they appear. (6) Destroy the affected plant. This is necessary only with certain pests. The grower must familiarize himself with the common maladies of his plants if he is to be able to apply the proper treatment.

The control of insects is based upon their habits and the changes which they undergo in their development. Some knowledge of the insect's development is therefore necessary if control measures are to be used effectively and intelligently. Insects are vulnerable at some period in their develop-

ment and it is at this point that control measures must be applied. These measures may be classified under three heads: mechanical methods, farm practices, destruction of the insect by spraying. Some of the more important mechanical methods are: (1) Hand picking. Most often practiced with cutworms, tomato worms and potato beetles. (2) Brushing methods. Slug-gish larvæ, as those of the asparagus beetle, may be brushed on hot soil. They die before they can return to the plant. (3) Covering with cloth or netting. This method is often used on vine crops while the plants are small, to keep off the squash bug and cucumber beetle. (4) Destroying affected plants or parts of plants. Light attacks of plant lice are sometimes treated in this way. (5) Covering the stem of the plant with paper to protect it against the attacks of stem-destroying insects. This is frequently used to prevent damage by cutworms to cabbage and tomato plants, and also against the cabbage maggot. (6) The use of repellents. The flea beetle and some other insects avoid plants which have been heavily sprayed with Bordeaux mixture. The striped cucumber beetle may be driven from melons and cucumbers by dusting the plants with fine air-slaked lime.

By farm practices is meant such sanitation measures as removing all rubbish and leaves after the crop has been harvested, cleaning out fence rows, rotating crops, fall plowing, using trap plants, and growing vigorous plants. Many insects pass the winter by hibernating either as adults or in the egg stage on the remains of the previous season's crop or on other rubbish which may be near at hand.

After the insect has invaded the crop it may often be killed by spraying. Practically all chewing insects may be killed by the use of stomach poisons. Paris green and arsenate of lead are the ones in most common use. The former is used at the rate of 1 to 1½ pounds to 100 gallons of water and the latter in the paste form at 4 to 6 pounds per 100 gallons of water, and 2 to 3 pounds to the same amount of water if powdered arsenate is used. Potato beetles, asparagus beetles, cabbage and tomato worms may be controlled at least in part by this method. Insects which suck the juices of the plant as the plant lice or aphids can only be controlled by the use of contact insecticides. Kerosene emulsion, nicotine preparations, tobacco decoctions and various sulphur sprays are the most common contact insecticides.

Classification of Crops—Vegetables may be grouped into two classes as to their temperature requirements: (1) Hardy plants, or those which are not injured by light frosts, and which germinate and thrive at comparatively low temperatures, and (2) tender plants, those which are injured or killed by frost and which require a temperature of at least 60 degrees for their successful culture. The hardy crops include beets, parsnips, carrots, spinach, radishes, celery, lettuce, cabbage, rhubarb, cress, peas, asparagus and cauliflower; while the most important tender crops are egg plant, pepper, beans, vine crops, tomatoes, sweet corn and sweet potatoes. According to their cultural requirements we may divide vegetables into seven classes, namely: (1) root crops, (2) cole crops, (3) foliage crops, (4) solanaceous

crops, (5) legumes, (6) cucurbits or vine crops, and (7) perennials. The culture of the more important vegetables under each of these groups is briefly given below.

Root Crops—The root crops include beets, carrots, parsnips, radishes, turnips, salsify and onions. In general, these crops make their best growth early in the spring at a comparatively low temperature, and they can be planted as early as the ground can be worked. They do best on a sandy loam soil because here they find the proper conditions for the development of a symmetrical root with few side roots. Heavy clay soils or shallow soils are to be avoided as much as possible for root crops. A muck soil is particularly good for onions and beets. The seed for these crops is sown in drills 24 to 36 inches apart. Cultivation should begin just as soon as the plants appear above the ground. When the crop is well established, the plants should be thinned to a distance of 2 to 5 inches, depending upon the crop. Radishes and early turnips must be harvested and used as soon as they mature. Onions should be harvested as soon as the tops fall over. They are cured in the field for a week and then the tops and roots are cut off, and the bulbs stored in a dry, well-ventilated place. They should not be piled upon each other to a greater depth than six inches. Carrots, beets, turnips, and rutabagas may be left in the field until after frost, while salsify and parsnips may be left in the ground all winter.

Cole Crops—The principal cole crops are cabbage, cauliflower, Brussels sprouts, kale and kohlrabi. They are all hardy crops which require a cool climate and abundant moisture for their best development. For early crops the seed should be started under glass in March. The plants are large enough to set in the field in from six to eight weeks. They should be transplanted at least once and hardened-off before they are set in the field. If properly hardened they may be set out as early in the season as the soil can be brought into condition for planting. A rich, moist soil is preferable for these crops. The fertility of the soil and its water-holding capacity can be increased by the use of large amounts of manure. Cabbage growers make exceedingly heavy applications of this fertilizer and some claim that it is practically impossible to get a cabbage soil too rich. To get a succession of cabbage and cauliflower, plant early and late varieties or plant early varieties at different times. The crop to be stored may be planted as late as July 1, but it should be planted early enough to be ready for storage before freezing weather, as cabbage should not be allowed to freeze before putting it in storage. The best varieties of early cabbage are Jersey Wakefield and Copenhagen Market; of midseason cabbage, Succession and Surehead; and of late cabbage, Volga or Danish Ballhead. The two latter are the best varieties for storage.

Foliage Crops—The foliage crops include lettuce, celery, Swiss chard, dandelion, spinach, cress, endive and parsley. Two of the most important, lettuce and spinach, are cool season crops which cannot endure the heat of summer. They should therefore be planted early in the spring

so that they will be mature by July 1. A muck or sandy loam soil which is rich in organic matter is best for this group. They use a great deal of nitrogen in their growth and nitrate of soda can be applied very profitably. Early leaf lettuce, head lettuce, celery, Swiss chard and endive are usually transplanted once before setting in the field and all except endive are started in the hotbed. The other crops of this group are planted in drills.

Lettuce, dandelion, spinach and cress are used to furnish a supply of green vegetables early in the spring and late in the fall, while Swiss chard and endive are used during the hot summer months. Perhaps the most important vegetable of this group is celery. A deep rich soil is necessary for its best development. The early crop is set out in May, while the crop for storing and late fall use is not planted until the last week of July. A large amount of moisture is necessary for a quick growth, and to secure this the soil may be mulched with well-rotted manure when the plants are about six inches high. Celery is blanched by excluding light from the stalks. It may be done by heaping soil around the plants or by placing boards along the sides of the row. There are two types of celery as regards blanching, the self-blanching and the green type. The former is used for summer and fall use and the latter for storing. A self-blanching celery can be blanched in about two to three weeks. The green celery for storing should not be blanched before it is harvested, as it keeps much longer when put into storage only partly blanched. Golden Self-Blanched and Winter Queen are standard varieties of their respective types. The latter is much better in quality.

The Solanaceous Crops—Among the solanaceous crops are found tomatoes, egg plant, pepper and potatoes, all of which are hot weather, long-season crops. The first three particularly delight in bright sunshine, hot weather, and a soil which has a large supply of moisture. These crops do best on a loam soil which contains a fair amount of humus. A clover sod is preferable for tomatoes and potatoes. A well-balanced ration is necessary for these crops; too much nitrogen will cause them to run to vegetative growth, while too much potash will make the fruit bitter. A fertilizer containing 2 per cent of nitrogen, 8 per cent of phosphoric acid, and 10 per cent of potash will help materially in increasing the tomato or potato crop. About 800 lbs. per acre should be applied. The seed for tomatoes, pepper, and egg plant should be sown in the hotbed at the same time that the early cabbage seed is started. The plants should be transplanted at least twice before they are set outdoors. They should not be planted in the field until the soil is warm and all danger of frost is past. Planting distances for the tomato are 4 by 4 feet and for egg plant and pepper, 18 by 30 inches. The best varieties of early tomatoes are Earliana and Bonny Best, and of late tomatoes, Stone and Matchless. Ruby King is the standard sweet pepper and Cayenne the best hot pepper. Black Beauty is the most popular variety of egg plant.

The Legumes—Only two legumes are commonly grown as vegetables; the bean and the pea. The temperature and soil requirements are different for the two crops. The bean is a tender, hot-weather plant, while the pea does best when the nights are cool. Peas are among the earliest crops sown in the garden. A succession of these delicious vegetables may be obtained by making plantings every two or three weeks until June 1. The Lima bean is a long-season crop and should be started in pots or berry boxes in the hotbed where the season is short. Peas and beans are planted in drills and should be thinned to four inches between plants. A loam soil only moderately rich in nitrogen is best suited for these crops. There are many varieties of peas and beans suited to many different conditions.

Vine Crops—The vine crops include cucumber, muskmelon, watermelon, pumpkin and squash. These are tender, long-season plants which thrive best during the hot summer months. They prefer sandy loam soil which is fairly rich in nitrogen and retentive of moisture. The planting distance for cucumber and muskmelon is about 5 x 5 feet; pumpkins and common squash should be planted 7 feet each way; summer or bush squash may be planted about 4 to 5 feet apart. In the North, muskmelons and watermelons planted directly in the field do not mature properly because of the short growing season. It is therefore a common practice to plant the seeds on inverted sods, in berry boxes or other receptacles in the hotbed about five weeks before time for planting them in the field. Four seeds are put in each box or on each section of sod. In setting the plants in the field do not disturb the root system more than necessary. Cucumbers are seldom started under glass.

The cucumber beetle is likely to attack the plants when quite small and unless attended to will soon destroy them. The beetles may be checked by covering the foliage of the plants with air-slaked lime or by putting a gauze or wire netting over the plant. Different varieties of cucumbers will cross readily among themselves, but the cucumber will not "mix" with melons or other cucurbit plants. The same is true of the other members of this group. The poor flavor found in melons at times is not due to mixture with other plants as is frequently supposed, but is the result of poor seed, poor soil, premature ripening, or to a diseased condition of the plant or fruit.

Perennial Vegetables—By perennial vegetables is meant those which grow year after year from the same root system. The most important of these are asparagus and rhubarb, although horse-radish and the artichokes may also be included in this group. Both rhubarb and asparagus are hardy vegetables which produce their edible product early in the spring before any of the vegetables grown from seed are ready for the table. They require a deep, rich, moist soil which has a

high content of humus. The edible crop comes from the food which is stored in the roots the season previous to that in which it is produced, so the aim should be to get as vigorous as possible a growth of top and roots after the cutting season is over. It is quite customary, therefore, to make two or three light applications of nitrate of soda during the cutting season and follow this with a heavy dressing of well-rotted manure when harvesting is finished.

Asparagus is grown from seed, but the average gardener will find it desirable to let the nurseryman grow the plants for him. The plants are set either at one or two years. The soil should be thoroughly prepared by deep plowing and harrowing. In planting a furrow is opened and the plants set with the crowns from eight to ten inches or more below the surface of the soil. Shallower planting will give an earlier crop in the spring but the bed will run out sooner. The crowns should not be covered more than an inch or two at planting, the remainder of the furrow being filled gradually during the summer by cultivation. Where only a few plants are to be set a trench two feet deep may be dug and the bottom filled with rich composted soil. The remainder of the operation is the same as for large plantings. Cropping should not be begun until the plants are three years old, and even then it should not be continued so late in the season as with older beds.

The crop is harvested either as blanched or green stalks. In the former method they are cut when the tips are about two inches above the surface of the soil. The stalk should be cut off about four to five inches below the surface. An asparagus knife is preferred for this purpose. The green stalks are cut when six to ten inches above the surface. In marketing asparagus may be bunched or sold in bulk. The former requires more work, but the product looks better and usually sells better.

Rhubarb is grown either from seed or by dividing the old plant. The crop is highly appreciated both as a forced vegetable or as an early season one grown out of doors. Rhubarb may be easily forced during the winter months in the cellar. The clumps should be dug in the fall and allowed to freeze before being brought in for forcing. They are set on the cellar floor and soil is packed around them so as to hold the roots in place and also hold a supply of moisture. Water should be supplied as needed but this will not be often, as the conditions do not favor rapid drying out. The temperature of the cellar should be kept at about 50 degrees. High temperature makes quicker production, but the crop is reduced. Light should be excluded, as the crop is much better and the production greater when the rhubarb is grown in darkness. Under favorable conditions about five weeks are required before the first stalks are large enough to cut. Bearing will continue for several weeks, depending upon the temperature and the strength of roots. Two to four-year old roots are best for forcing. After forcing they are practically worthless and should be thrown away.

When grown out of doors, rhubarb should be supplied with liberal amounts of manure. It should be applied after cropping has ceased and be thoroughly worked into the soil around the plants. Flower stalks should be removed as soon as they appear. Cropping may continue quite late in the season, but it should not be so severe or continued so long that the plant will not be able to recuperate before the end of the growing season. Remember the production of next year's crop depends very largely upon how much food the plant stores after harvest this year. Rhubarb may be had somewhat earlier if a box or frame is set over a few plants, covered with storm or hotbed sash, and the sides banked with fresh horse manure.

Quantity of Seed Required — In ordering garden seed one is sometimes perplexed as to how much is necessary for a given amount of land. The following list of the common vegetables and the amount of seed needed for seeding definite areas is given by Prof. R. L. Watts in his book on Vegetable Gardening.

- Asparagus — $2\frac{1}{2}$ oz. per 100 feet of drill; 2 pounds per acre.
- Beans (dwarf) — 1 quart to 100 feet of drill; $1\frac{3}{4}$ bu. per acre.
- Lima Beans — $\frac{3}{4}$ bu. per acre.
- Pole Beans — $\frac{1}{4}$ bu. per acre.
- Beets — 1 oz. to 50 feet of drill; 4 pounds per acre.
- Broccoli — 1 oz. to 300 feet of drill; 4 pounds per acre.
- Cabbage — 1 oz. to 300 feet of drill; 1 pound per acre.
- Carrots — 1 oz. to 100 feet of drill; $2\frac{1}{2}$ pounds per acre.
- Cauliflower — 1 oz. for 4,000 plants.
- Celery — $\frac{1}{3}$ oz. to 100 feet of drill; 1 oz. produces 10,000 plants.
- Sweet Corn — $\frac{1}{2}$ pint per 100 hills; 1 pk. per acre.
- Cucumbers — 1 to 2 oz. to 100 hills; 1 to 2 pounds per acre.
- Egg plant — 1 oz. for 2,000 plants.
- Endive — $\frac{1}{4}$ oz. to 100 feet of drill; $4\frac{1}{2}$ pounds per acre.
- Kale — 1 oz. to 300 feet of drill.
- Kohlrabi — 1 oz. to 300 feet of drill; 4 pounds per acre.
- Leek — 1 oz. to 100 feet of drill; 4 pounds per acre.
- Lettuce — $\frac{1}{4}$ oz. to 100 feet of drill; 3 pounds per acre.
- Onion — $\frac{1}{2}$ oz. to 100 feet of drill; 5 pounds per acre.
- Onion Sets — 1 quart to 40 feet of drill; 8 bu. per acre.
- Parsley — $\frac{1}{2}$ oz. to 100 feet of drill; 3 pounds per acre.
- Peas — 1 to 2 pints to 100 feet of drill; 2 bu. per acre.
- Pepper — 1 oz. should produce 1,500 plants.
- Radish — 1 oz. to 100 feet of drill; 10 to 12 pounds per acre.
- Rhubarb — 1 oz. to 125 feet of drill; $3\frac{1}{2}$ pounds per acre.
- Salsify — 1 oz. to 100 feet of drill; 8 pounds per acre.
- Spinach — 1 oz. to 100 feet of drill; 8 pounds per acre.

Squash — 4 to 8 oz. to 100 hills.

Tomatoes — 1 oz. produces 3,000 to 4,000 plants.

Turnip — 1 oz. to 200 feet of drill; 1 to 2 pounds per acre.

Watermelons — 1 oz. to 30 hills.



One method of planting

Courtesy of New York State College of Agriculture

CHAPTER II.

THE FLOWER GARDEN

- I. INTRODUCTION. II. USES OF FLOWERS—IN HOUSE BORDERS—IN SHRUB BORDERS—ON THE LAWN—AS SEPARATE GARDENS. III. CARE OF FLOWERING PLANTS—SOIL—PREPARATION OF SOIL—PLANTING AND SOWING SEED—STARTING ANNUALS—CARE OF FLOWERS. IV. KINDS OF PLANTS—HERBACEOUS PERENNIALS—ANNUALS—BULBS—DAHLIA—CANNA—ANNUAL VINES—SHRUBS.

Introduction — There is no feature of the home grounds which gives more pleasure or adds more to the attractiveness of the place than flowers properly used. Nearly everyone likes flowers and appreciates their value; but a great many, because of lack of familiarity as to best methods of treatment, so use them that they detract from the grounds rather than add to their beauty. Flowers properly handled give variety, add color and serve a number of useful purposes; improperly handled, they destroy the beauty of the lawn, offend the sense of color harmony, and in many instances might better be left out of the planting.

The first thing one must learn when he sets out to improve the grounds surrounding his home is that he is creating a picture. The rules which the artist follows in creating his picture upon a canvas apply in a very large measure to the creating of a landscape picture, and he who plants shrubs and flowers should recognize some of the more important of these before starting upon his work. It is impossible to go into detail as to all of the principles which one should recognize, but the

consideration of a few of the more fundamental ones will help us to avoid serious mistakes.

In the average landscape picture, in connection with a residence, the house is the main feature of the picture. The planting, therefore, should be so planned and arranged that it will harmonize with the house and add to its attractiveness, rather than hide it and minimize its importance in the picture. It should aim to give the house a natural setting and make it appear as an integral part of the place, rather than an object set down without any connection or relation to its surroundings. A well-planned planting therefore will consider the background for the house and the question of "tying" the house to the grounds by planting at its base. It will be so arranged as to hide objectionable outside features and to disguise artificial boundary lines such as fences. In most



Fig. 1.—A plain farm home, but a pleasant place in which to live. The broad lawn adds greatly to the appearance and comfort of the place.

Courtesy of New York State College of Agriculture

places it will assist in drawing adjoining buildings into the picture harmoniously and relieve as far as possible the harshness of such features of utility as drives and walks. The planting must be so arranged that it will not destroy the unity of the lawn or become a discordant feature which might detract from its dignity.

Too often in our planting, we fail to recognize the fact that the open lawn is of much greater importance in giving the house the proper setting than is the planting of the grounds. To be sure, neither one is complete without the other, but the general tendency is to sacrifice the lawn too much to the planting.

Uses of Flowers

In beautifying the grounds flowers offer many possibilities. The uses to which they may be put fall more or less naturally into three

divisions: in borders, about the lawn, and in separate gardens. On small grounds flowers are usually best seen in the first two uses. We may dividé borders roughly into house borders and shrub borders. The former is the planting at the base of the house, the purpose of which is to furnish a natural connection between the grounds and the building.

Flowers in the House Border—This is one of the best places for growing flowers. The angles formed by porches or two parts of the



Fig. 2. The planting at the base of the house from the wood work is a pleasant porch corner.

building not only offer good places for planting flowers but really demand it to soften the severity of the lines. The planting does not need to be confined to angles only. Plants may be set along the sides of the house at any point, and so long as they do not interfere with the light they will be of value in giving that natural appearance previously mentioned.

The house border should not be composed entirely of flowering plants which kill with frost. A judicious combination of shrubs, vines and herbaceous flowers will give the best effect. Neither should the house border be continuous; at various points the fact that the wall actually comes to the ground should be apparent. The herbaceous flowers in the house border may be displayed at the sides of the shrubs or in front of them. The latter method gives the most satisfactory results where the space available will permit of a rather deep planting. The lines of the border should be those of graceful curves, as the effect will be much more pleasing than if they are straight. In the use of flowering plants in the house border, the bulbous plants should not be overlooked. These are unsurpassed in giving early effects and may later be replaced with annuals, the combination making possible a long period in which the border will show bloom.

Flowers in the Shrub Border—Where the grounds are large, shrub borders along the boundaries offer a very fine opportunity for the growing of flowers. Here the flowers are usually displayed in front of the shrubs. This is the preferable method as the shrubs afford a background for the flowers and they make a much better appearance than when there is no background. Almost all herbaceous flowers can be utilized in the shrub border; its limitations in this respect being much fewer than those of the house border.

Flowers on the Lawn—Possibly the most frequent use of flowers is in beds on the lawn, usually between the house and the street.

It is unfortunate that the lovers of flowers make this mistake in their location. Flowers so used are out of place, as they spoil the harmony of the lawn and detract from the appearance of the place rather than add to it. Because of this, the bed in the open lawn should be removed and the flowers grown in some other location. Bulbs are often used in the open lawn but they are scattered in the grass, not set in distinct beds. This method of growing bulbs is known as "naturalizing." Even in this method of treatment it is much more desirable to have the plants located close to the borders or in recesses in the shrub planting. The tulip, daffodil, crocus, snowdrop and pheasant's eye narcissus are among the bulbous plants most often used for this purpose. If displayed against a shrub background, the bulb clump should be densest at the rear and thin gradually toward the front edge; or if displayed more in the open, the center should be the densest. The object to be secured by such arrangement is the appearance of natural growth, avoiding the look of set planting.



Fig. 3.—An Attractive House Corner.

Flowers in a Separate Garden—The separate flower garden offers possibilities which are not to be secured by any of the other methods of handling flowers. Here can be grown favorites which possibly are not suitable in the borders. The flowers in the border are often not available for cut flowers, but in the flower garden provision may be made for abundant supplies. If the grounds are of sufficient extent the flower garden may be made one of the most attractive features of the landscape. The flower garden must be carefully planned if best results are to be had. It may be treated as a single unit, or as several units making a composite whole. In the former method all parts of the garden are seen at once from some well-chosen vantage spot. The taller plants will be set at the rear and as backgrounds for the shorter growing ones. The whole garden may be shut off from the remainder of the grounds by a shrub border or hedge, and this in turn will give a background for the taller flowers. Great care should be exercised to choose plants which will harmonize well in their color combinations as well as those which are suitable in height. Plant so that the bloom will be scattered over the different parts of the garden throughout the entire summer and no

portion will look ragged, spoiling the effect of the whole garden. The beds should have gracefully curving edges, unless you have planned a formal garden, and the line of separation between flower bed and walk should be a distinct one.

Some prefer to have a garden in which one type of flower predominates and the others are subordinate. Although it is a little more difficult to plan a garden of this type, in the end it is usually more satisfactory. The "several-unit" garden lends itself to this form of planting also, but more often the



Fig. 4.—*Xanthorhiza* is an attractive shrub for the border and does not mind the shade of trees.

various units have a central feature of their own and all are blended into a composite whole. The selection of two leading plants is often resorted to in order that the length of the flowering season may be increased. As an example, the leading expression of a garden during the early part of the season might be secured by the use of a bulbous plant, to be later followed by some annual or perennial which would continue the blossoming until well into the autumn.

Location—The flower garden should be located in rear of the house or well towards the rear at one side. Of course, if it is properly

screened it may be located nearer the front, but this is usually not so satisfactory. The exposure will depend somewhat on the kind of flowers to be grown. As a rule it should be south or east as this is the best exposure for the majority of plants.

CARE OF FLOWERING PLANTS

Soil—The soil for the general flower garden should be a rich loam tending towards a sandy loam rather than a clay loam. It should be well



Fig. 5.—Foxglove. A pleasant outlook.

Courtesy of New York State College of Agriculture

drained, but have a good water-holding capacity. This will mean that it must contain a goodly amount of decaying vegetable matter. Fortunately the fertility of the soil and its vegetable (organic) content can be kept up by the same cultural practice, the application of well-rotted or composted manure. The manure does not need to be all manure from the stable, but there may be added to it mowed grass and leaves taken from the lawn. This should be piled up with the manure and allowed to decay thoroughly. It is not advisable to use fresh manure if it is possible to secure the other.

Preparing the Soil—The preparation of the soil is an important matter in securing good results. Put a liberal amount of manure on the plot to be used, and then spade it into the soil. After a spading, rake and



Fig. 6.—The easily grown Tiger Lily should be in every garden.

cultivate the soil until it is as fine as possible. Fine soil is essential for two reasons: it enables the seed to germinate more readily, and it conserves the moisture much better than coarse. In working the soil care should be taken not to tramp over it any more than is necessary. This is particularly important after the final raking has been made.

Planting and Sowing Seed—

Plants usually found in the flower garden may be classed under two heads as to their length of life; those for which the seed must be sown every year, known as annuals, and those which live for a number of years without replacing, known as perennials. Perennials may be secured in either of two ways: by sowing seed or by planting parts of parent plants grown by nurserymen. If seeds are used one must expect to

wait until the second year for the blossoms, at least with most varieties. Many people prefer to buy their plants in starting a garden and thereafter grow their own, either from seed or by dividing the mother plant, depending upon the nurseryman only for the new kinds and new varieties.

The time at which perennial seed should be sown depends upon the kind of plant and the desires of the grower. Many prefer to start the seed in pans or boxes indoors. The seed is sown in rather light soil the latter part of March, or in April or May, depending upon the latitude. If sown outdoors most kinds of seed will be sown in late summer or early fall. Small seeds should be covered very little and the larger kinds not so deep as is usually done. A safe rule to follow is to cover the same depth as the thickness of the seed. After the ground is frozen slightly, cover with an inch or two of mulch. Whichever method is used the seedling plants will



Fig. 8.—Perennial Phlox.

need to be transplanted. Those sown indoors may be set directly in the flower bed, but more often they are transplanted once indoors before setting in the open. They should be hardened off before planting out of doors as described for vegetable seedlings in the previous chapter.

Starting Annuals — For early flowering, annuals should be started indoors in the same way as perennials. It is a very good practice to make a second sowing about two weeks after the first to provide for a succession of flowers and against loss of the first seeding. The plantlets should be transplanted into larger flats or boxes as soon as they have produced the first true leaves. If they are left in the original seed pan they are very likely to grow tall and "leggy" and make poor plants for setting out-of-doors. Care in watering, shading, particularly if grown in hotbeds or cold-frames, and in cultivation is necessary if the best plants are to be secured. With plants inclined to grow spindly, it is best to pinch out the tips when they get two or three inches high. This makes them branch out and produces good stocky plants. Harden off before setting in the open. Seeds for most kinds may be started out-of-doors after the season is sufficiently advanced beyond danger of frosts. With a number of plants, such as asters, sowing may take place rather early. Field-sown seed produces plants which flower later than those started indoors, and in some sections certain kinds will scarcely arrive at their best before they are killed by the frost.

Some florists make other classes: hardy annuals, half-hardy annuals, tender annuals; hardy, half-hardy and tender biennials; and hardy, half-hardy and tender perennials. Those classed as tender and half-hardy are best started indoors; those classed as hardy may be started either in or out-of-doors.

Care of Flowers—No matter how good the plants are or how suitable the soil, if they are not cared for after planting, the garden will be a failure. The garden should be no larger than the grower can care for properly. Small gardens well cared for are much to be preferred to large gardens half neglected. Cultural practices will differ somewhat with different kinds of flowers, but there are some that are common to all.

Cultivation is absolutely essential to success. A great many people cultivate to keep down the weeds. This is to be commended, but cultivation which stops there is usually insufficient. The chief object in cultivation should be to conserve the moisture. This means that the ground should be kept in such condition that there is a mulch of dust from one to two inches deep over the surface at all times. Cultivation must be constant to accomplish this end. It must take place after every rain which is sufficient to pack the surface soil, and at least every two weeks whether it rains or not. If this is done the weed problem will be solved incidentally. Plants must have food and moisture to produce flowers and cultivation is one of the best means of providing both of them.

Even with thorough cultivation there may come times when there is insufficient moisture for the growth of the plants. Watering or irrigation is

then necessary. A great many people water plants, but few of them do it correctly. Most people apply too little water when supplying it artificially. Sprinkling or pouring a little water over the surface often does more harm than good. If you must apply water artificially, put on enough to soak the soil at least six inches deep, a foot would be better, and then withhold water until there is evidence that another application is needed.

The pests of our common flowers are usually not serious. One should always be on the look-out for them however, and be ready to combat them as soon as they appear. There are some diseases of flowering plants such as



Fig. 9.—The bright colors of Sweet-William look well in the open border.

aster yellows, which are not well understood and for which no remedy is known. Plants which show a dwarfing and yellowing of the foliage had best be pulled out and destroyed at once.

KINDS OF PLANTS

It is impossible to mention in a chapter of this length all the desirable plants, as they will vary materially in different sections and to a large degree with the tastes of the growers. There are some plants, however, which are widely grown because of their adaptability to many environments. A few of the best known sorts will be considered.

Herbaceous Perennials — These plants live from year to year but usually give best results the second and third year. After the third year they should be divided, so as to give the plant a new start and allow for new

growth without crowding. They are especially valuable for shrub and house borders, and where permanent effects are desired. They require less care than annuals and cover a long season, some of them being among the earliest bloomers, while others are in blossom until killed by frost. Among the more popular are: peony, perennial phlox, bleeding-heart, perennial asters, pyrethrum, balloon flowers, hollyhock, oriental poppy, Iceland poppy, fox-glove, larkspur, various campanulas, achillea ("the pearl"), columbine (aquilegia), boltonia, iris of various kinds, and many others.



Fig. 10.—The beautiful German Iris.

Annual Flowers — Although the herbaceous perennials are very popular in garden work, there seems to be even a larger list of popular annuals. The annuals are best fitted to separate flower garden work, although they do find a place in the house border and not infrequently in the shrub border. Varieties can be found covering nearly the entire growing season, and with successive plantings some of the choicer kinds may be had for much longer periods than they commonly are. The following are a few which may be used in almost any flower garden.

Aster, of which there are many kinds, best used for mass effects.

Ageratum, a low growing plant suitable for borders.

Alyssum, a good border plant or suitable for mass effects where a low plant is desired.

Balsam, one of the old favorites, but should not be planted close if good effects are desired.

Calliopsis and *Coreopsis* may be had in various heights and color-combinations of yellow and deep red, a most profuse and long blooming annual.

Cosmos, magnificent foliage and numerous flowers, must be sown early and dwarf kinds used if best results are to be secured in the north.

California poppy, a low growing plant with numerous yellow and whitish flowers.

Dianthus (Pink) will give a profusion of bloom from July until it is killed by frost. It is exceedingly ornamental and is equally suitable for beds, borders, house decorations and cuttings.

Marigold, an old-fashioned favorite with rather a disagreeable odor, but the large-flowered French and African types give very satisfactory mass effects of yellow and dark red.

Mignonette, popular with many because of its delightful fragrance.

Pansy, probably the most popular annual, good for border planting, but best seen in mass effects, also desirable for cut flowers.

Petunias are effective in borders and beds and for cut flowers.

Annual phlox, a very satisfactory edging plant or does well in mass effects.

Annual poppy, almost as popular as the pansy, may be had in many different colors and several types.

Salpiglossis, a rather hard plant to grow, but well worth the trouble, its funnel-shaped many colored flowers being a fine addition to any collection of annuals.

Salvia, the king of late bloomers, its brilliant reds in mass effects in late summer and autumn cannot be surpassed.

Snapdragon, a perennial but usually grown as an annual, may be grown from seed or selected kinds from cuttings, blooms profusely, and if properly handled produces two or three crops of flowers a year.

Verbena, a low-growing rather trailing plant, is good for borders, boxes, mass effects; has a very long season of bloom.

Zinna, not liked by many because of its gaudy effect when grown en-masse in mixed colors; selected colors or varieties give charming mass effects.

Bulbs — Bulbs are particularly valuable because of their early blooming. They may be used in beds early in the season and later replaced by annuals or perennials. They find a place in shrub and house borders, naturalized in the lawn and in mass effects in formal treatments. For early spring flowering tulip, trumpet daffodil, pheasant's eye narcissus, hyacinth, crocus and snowdrop are very satisfactory. Lilies belong to this class and there are a number of kinds which add materially to the beauty of the garden.

The tiger lily is one of the easiest to grow and is recommended for beginners. There are many other kinds, but those not experienced in lily growing should begin on a small scale until they have mastered the details of culture.

Giladiolus, although not strictly a bulb, is usually considered with this group. It blooms from mid-summer until fall and is very attractive. It is not hardy and should not be planted until danger of frost is past, and should be taken up in the fall before the ground freezes much.

The dahlia is handled much the same as an annual in the north, but there are some differences in detail of culture which makes separate consideration desirable. The dahlia is commonly grown from cuttings or portions of the old plant. Cuttings are either secured from the florist or from plants which have been carried over from the previous season and forced into early growth. The cuttings thus secured are rooted in a cutting bench and planted

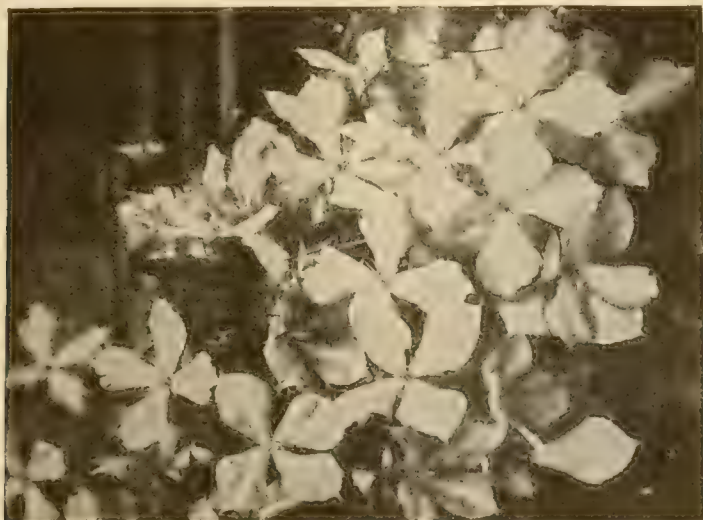

Fig. 11.—*Clematis Jackmani*, one of the most beautiful of flowering vines.

in the field when danger of frost is past. The other method of propagation, and the more common one in small gardens is to divide the mother plant, either planting immediately in the field or starting indoors and later transplanting to the field. In most sections the former method will prove more satisfactory. In breaking up the parent plant, care should be taken to take with the fleshy root, or toe as it is sometimes called, a portion of the stem bearing a bud. The root of the dahlia does not ordinarily produce buds, and unless there is a bud carried on the portion of stem attached to the root, it is not probable that that root will produce a plant. In order to be certain about the presence of a bud, many growers prefer to have the plants begin growth before dividing the mother plant.

Dahlias need a rich soil and one which will hold lots of moisture. There is danger, however, of getting the soil too rich and causing the plant to

expend most of its energy in producing foliage. After the tops have been killed by frost, dig the plants, cut off the tops, knock off most of the loose earth clinging to the roots and store in a place suitable for keeping potatoes.

The canna is much prized as a plant to use in mass bedding of a formal nature. It thrives best under about the same conditions as the dahlia, although it is not quite so particular as to soil conditions. It may be propagated from seeds, but the more common method is by division of the plant. The canna produces strong buds at the surface of the ground. In separating the mother plant, one or more of these buds are taken with each division to produce new plants

Vines — A few annual flowering plants which are popular in gardens are best considered as vines. These plants are valuable for covering



Fig. 12.—Dorothy Perkins Climbing Rose.

unsightly objects, such as fences or buildings, which might detract from the beauty of the garden. If there is no occasion to use them in this way they may be trained on trellises and are very acceptable in the garden. The sweet pea is one of the most prized of these climbing plants. It thrives best in a fairly fertile soil, in a rather cool location. There are hundreds of varieties possessing many colors and combinations of colors from which to choose. Plant lice are its most troublesome pest and constant attention must be given to keep the vines free from them. Strong soap suds, or better still, tobacco extracts if properly applied, will be effective. The morning glory is a favorite and no better plant

can be found for covering wire fences. The climbing nasturtium, although a lower growing plant is very satisfactory for covering low objects and it is especially valuable as a source of cut flowers for indoor use. The wild cucumber is sometimes used for special purposes such as concealing outhouses and dump holes. Its chief advantage lies in its very rapid growth. It is one of the most satisfactory annuals for porch vines and is equally adapted to covering fences or other objectionable objects.

For a permanent flowering vine, one of the showiest is the clematis. It thrives in most soils and gives a profusion of beautiful flowers. The variety called *Clematis Paniculata* bears small white starry blossoms in thick clusters. The *Clematis Jackmani* bears large single flowers in white and purple. Nothing is more beautiful than the various climbing roses. The *Dorothy Perkins* with its shell pink clusters of bloom is a great favorite. The crimson Rambler is equally popular. Although rose culture is an art by itself, these varieties are both quite hardy and prove irresistible to most flower lovers.

Shrubs—It is not necessary to resort to strange and unknown shrubs for the border. The honeysuckle, the high bush cranberry, the dogwood, the elder, and even cultivated varieties of the sumac are as beautiful as many of the imported varieties. The glow of the latter's autumn foliage makes it worthy of a place upon the lawn. Such old favorites as the syringa, spirea, lilac and snowball should not be supplanted. They repay many times for the labor they require, and for beauty and fragrance are unsurpassed among flowering shrubs. *Xanthorrhiza* or yellow root will be found an excellent grower under trees or in shady places.

The following table will be of assistance in choosing plants for combinations and to provide a long season of flowering.

PLANTING TABLE FOR THE EASTERN, CENTRAL AND MIDDLE WESTERN STATES

Name of flower	Amount of seed for 10 ft. of row		Time to plant		Distance apart (inches)		Depth to plant seed (inches)	Hardy, half-hardy, or tender	Height to which plants grow (feet)	Annual—A Biennial—B Perennial—P	Season of blooming
	Hotbed	Open ground	Between rows		Between plants in row						
Ageratum	March	May	12	6	1 1/2 to 3 1/2	Hardy	1 1/2 to 3 1/2	A	June to frost		
Alyssum	March	May	12	12	3 1/2 to 12	Hardy	3 1/2 to 12	A	June to frost		
Anthrinum	March	May	12	12	3 1/2 to 12	Hardy	3 1/2 to 12	P	July to frost		
Bachelor's button	March	May	12	12	3 1/2 to 12	Hardy	3 1/2 to 12	A, P	July to Oct.		
Balsam	April	May	24	24	1 to 3	Tender	2 to 3	A	July to frost		
Calendula	April	May	12	6	2 to 12	Hardy	2 to 12	A	June to Oct.		
Campanula	April or May	May	12 to 18	12	3 1/2 to 12	Hardy	3 1/2 to 12	A, P	June to Oct.		
Caraway	April	May	18	6	1 to 6	Half-hardy	1 to 6	A	June to Oct.		
Chrysanthemum	April	May	18	8	1 to 12	Hardy	1 to 12	A	June to Oct.		
Chrysanthemum	April	May	18	12	1 to 12	Hardy	1 to 12	A	June to Oct.		
Cockscomb	April	May	24	24	1 to 1 1/2	Hardy	1 to 1 1/2	A	June to Oct.		
Convolvulus (morning-glory)	April	April	To climb on some support	6	1 1/2 to 3 1/2	Hardy	1 1/2 to 3 1/2	A	June to frost		
Cornopsis	March	April	18	10	1 1/2 to 2 1/2	Hardy	1 1/2 to 2 1/2	A, P	June to frost		
Cosmos	April	May	24 to 30	24	1 1/2 to 2 1/2	Hardy	1 1/2 to 2 1/2	A	July on*		
Dahlia	March	May	12 to 18	6	4	Half-hardy	4	P	Aug. to frost		
Dianthus	March	May 1 to 10	12 to 18	6	1 to 1 1/2	Half-hardy	1 to 1 1/2	A, P	July to frost		
Hollyhock	March	July to September	24 to 36	15	1 to 1 1/2	Hardy	1 to 1 1/2	A, P	Aug. to frost		
Larkspur	March	May	12	12	1 to 1 1/2	Hardy	1 to 1 1/2	A, P	July to frost		
Margold	April	May	12	6	1 to 1 1/2	Tender to half-hardy	1 to 1 1/2	A	June to Sept.		
Miscanthus	March	May	12	12	1 to 1 1/2	Half-hardy	1 to 1 1/2	A	July to frost		
Nasturtium	April	May	12	12	3 to 1	Hardy	3 to 1	A	July to frost		
Pansy	March	April	12	6	1 to 1 1/2	Hardy	1 to 1 1/2	A	April to frost		
Petunia	Feb. or Mar.	May	12	12	1	Hardy	1	A	June to frost		
Phlox (annual)	March	May	18	12	1 to 2	Hardy	1 to 2	A	June to frost		
Poppy	March	Apr., Sept., Oct.	12	12	1 to 2	Hardy	1 to 2	A	June to frost		
Salvia	March	May	24	18	2 to 3	Half-hardy—P to hardy—A	2 to 3	A, P	Aug. to frost		
Stock	March	May	18	12	1 to 1 1/2	Hardy	1 to 1 1/2	A, B	July to Sept.		
Sunflower	April	May	36 to 60	24 or more	6 to 10	Hardy	6 to 10	A	Aug.		
Sweet peas	March	June	36 to 48	Thick	2 to 6	Very hardy	2 to 6	A	July to Sept.		
Sweet William	March	June	12	6	1 1/2 to 2	Hardy	1 1/2 to 2	A, P	June, July		

*Early, July to August. Late, September to October.

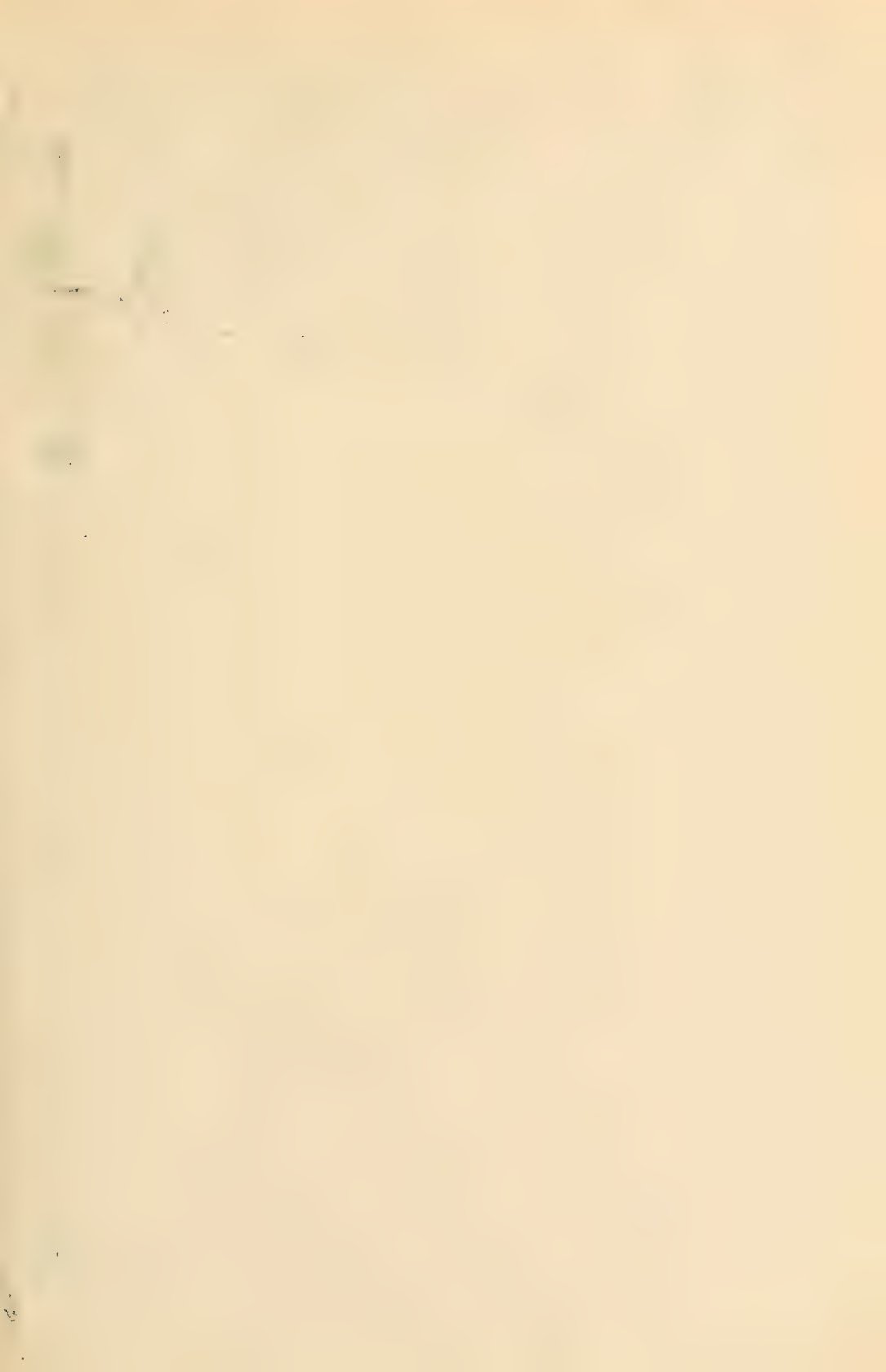



Probably the Most Productive Apple Tree in the World. Its Record for One Year was 126½ Boxes of Marketable Fruit.
Courtesy of the Walla Walla Commercial Club, Walla Walla, Wash.



Fig. 1.—Intelligent selection of nursery stock is the first step toward a profitable orchard. Choose well-formed, low-headed, one- or two-year-old trees rather than high-headed, older ones

Courtesy of the Wisconsin Experiment Station.

CHAPTER III.

PLANTING THE COMMERCIAL ORCHARD

- I. SELECTING THE SITE—SOIL—SUBSOIL—ELEVATION—EXPOSURE. II. PLANTING THE ORCHARD—SQUARE SYSTEM—QUINCUNX—ALTERNATE—HEXAGONAL. III. DISTANCE OF PLANTING—TABLE FOR NUMBER OF TREES PER ACRE—USE OF FILLERS. IV. LAYING OUT THE ORCHARD—WIRE METHOD—LINING-IN-METHOD—MARKING WITH THE PLOW—STAKING FOR HEXAGONAL SYSTEM—METHOD OF LOCATING TREES. V. SELECTING TREES FOR PLANTING—AGE OF TREES—HOW TO DETERMINE AGE OF TREES—HEIGHT OF HEAD—DISTRIBUTION AND NUMBER OF BRANCHES. VI. POINTERS IN ORDERING NURSERY STOCK—DIRECT DEALING WITH NURSERYMEN—STATE CHARACTER OF TREES DESIRED—KEEP COPY OF ORDER—PAY A GOOD PRICE. VII. CARE OF TREES ON ARRIVAL. VIII. TIME FOR PLANTING. IX. SETTING THE TREES—SIZE OF HOLE—ROOT PRUNING—ROOT DISTRIBUTION—SLANT OF TREE IN PLANTING—FILLING THE HOLE—FERTILIZING—WATERING—MULCHING. X. TOP-PRUNING YOUNG TREES—CUTTING BACK THE TOP.

The man who starts an orchard often fails because he is unfamiliar with the business. Selecting a site, the best method of laying out, the proper distance apart to plant, the best way to prune, how to take care of trees when they arrive too soon, the time to plant, fertilizers, and care of wounds, are a few of the problems that will call for an answer.

We have tried to make the subject sufficiently clear so that the reader who familiarizes himself with the following chapters will be able to succeed in his effort to start and maintain an orchard.

SELECTING THE SITE

Three chief factors enter into the selection of the site for an orchard — soil, elevation, and exposure. Of these the soil is most important for even though the elevation and exposure be perfect, if the soil is unfavorable, the orchard will be a failure.

Orchard Soils Vary — Different fruits, and in some cases even different varieties of the same kind, have different soil preferences. Apples seem to prefer, as a rule, soils of a somewhat clayey nature. In the past the tendency has been to select rather heavy clay-loam or clay soils. Less heavy clay-loams and even soils tending towards a gravelly nature seem to give better results. Heavy clays are much more difficult to handle, have a tendency to carry the wood growth too late into the summer, and do not give as good color to the fruit as do the somewhat lighter soils. Both late growth and low color are objectionable and for these reasons heavy clays should be avoided where more suitable soils are available. It is not to be understood that light or sandy soils are preferred for apple growing. Pears do best on heavy soils, peaches on rather light soils, while plums and cherries vary considerably according to the particular species under culture.

The depth of soil necessary for good results depends very largely upon the character of the subsoil. With a suitable subsoil very little surface soil is necessary for success. Good results are often obtained where there is but two feet or less of surface soil underlaid by a suitable subsoil.

Pervious Limestone Subsoil Preferred — This type of subsoil permits the roots to work deeply into it, giving trees with extensive root systems. The limestone also aids in the production of high color which is so essential in a good market fruit. A gravelly subsoil would be second choice in selecting an orchard site.

Impervious subsoils are to be avoided, especially if they come close to the surface. Such a subsoil hinders deep rooting and not infrequently brings the water table so close to the surface that the root system is confined to a shallow layer just under the surface. An orchard planted on such a soil is sure to be a failure unless the subsoil be broken up and the water table lowered by drainage.

Have the Orchard Site Elevated Above the Surrounding Country — This does not mean that it must be the highest piece of land in the vicinity, but that it should have lower levels in proximity to it. Elevation is an important factor in fruit growing. There is always a possibility of damage from late spring frosts during the flowering period and orchards on low or level land suffer first. A rolling site which provides good air drainage and which is somewhat elevated is most likely to escape injury from frosts.

Avoid "Pockets" — It is not only necessary to select elevated sites, but when these sites are in small valleys it is important that the valley be open at its lower end. If it is not, such a valley becomes a "pocket," and because of lack of air drainage is very susceptible to frosts, and unsuitable for fruit growing. "Pot-holes," especially if of considerable extent, are best left unplanted as the trees seldom give good results.

Best Exposure — Exposure is the direction of slope of the site. By a northern exposure is meant a site in which the general slope of the land is towards the north. On rolling sites, it is impossible to have all the land slope in the same direction, but in such cases it is the general slope which is considered. No one exposure is best under all conditions. As a rule a northern or northeastern exposure is preferable.



Fig. 2.—The orchard should usually slope to the north. This lessens danger from late frosts

Courtesy of the Wisconsin Experiment Station.

The trees are slower in coming into blossom in the spring than when the orchard has a southerly exposure, and therefore there is less danger from late spring frosts. Near large bodies of water best results are secured by having the exposure toward the water. In regions of high winds, much damage often results from fruit being blown off and from rapid evaporation of moisture. These injuries are reduced by choosing a site which has an exposure away from prevailing winds. Fortunately, in most locations this direction will be north or northeast, and thus coincides with the general exposure. When earliness is desired and there is little or no danger from frosts a southern exposure is preferred.

PLANTING THE ORCHARD

One of the first considerations in planting the orchard is the preparation of the land. It is true that orchards can be planted on land that has been poorly prepared, but as a rule the difficulties which later arise

more than offset the supposed gain. There are instances in which it would be unwise to lose a year's growth of the trees in order to put the land chosen for the orchard in an ideal condition. In the majority of instances, the planting of a commercial orchard is not decided upon so suddenly that preparation previous to planting is not possible.

Preparation for planting should consider at least the character of the surface soil, and the subsoil. With the ideal subsoil no attention need be given, but where the subsoil, or even the lower portion of the surface soil is a compact clay, then subsoiling should be done. The additional root system secured in two seasons by this operation will more than pay for it.

The surface soil should be considered from two standpoints—the character of the tilth, and the presence of organic material. While the former is more or less dependent upon the latter, the degree of fineness is a matter that should not be overlooked. A clover sod, or still better, a crop of clover, ploughed under, followed by a cultivated crop,

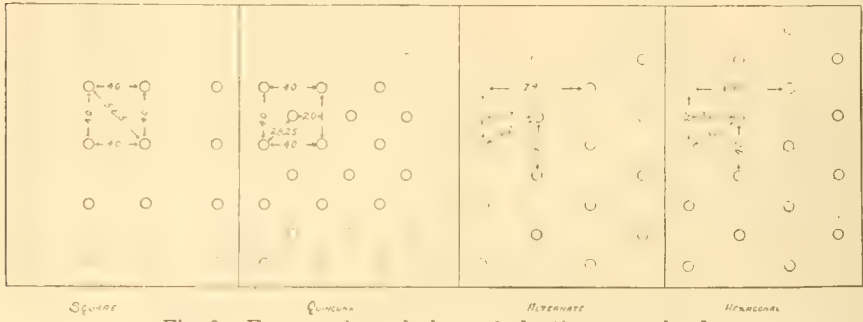

Fig. 3.—Four much used plans of planting an orchard.

preferably corn, grown upon the land, puts the soil in the best possible condition for the planting of trees the following year. Frequent cultivation of the crop so as to put the soil in good tilth is essential. The clover which has been turned under adds both organic matter and nitrogen which assists in a vigorous growth of the trees the season planted. If the soil has been put in good condition little work is necessary in the spring before planting. The land may have been ploughed the fall previous or just before planting. Fall ploughing usually permits of earlier setting of trees. A couple of diskings or harrowings just before planting puts the soil in fine condition to receive the trees.

PLANTING PLANS

There are numerous systems for planting orchards. Many fruit growers have worked out their own systems. Those mostly used are the rectangular, quincunx, alternate and hexagonal, or modifications of them.

The Rectangular or Square System is most used. In this plan the trees are set at the corners of a rectangular area. Most often the rectangle

is a square, but not infrequently the sides are unequal. This is the simplest system to lay out. Its chief disadvantage is that it does not make economical use of the land, there being an area in the center of each rectangle little used by the trees.

The Quincunx System was devised to offset the difficulty just mentioned. It is an alternate system of which the square system is the basis. A fifth tree is set in the center of the square which reduces the distance between the rows one-half and practically doubles the number of trees. For example, where trees are set thirty feet between the rows, and thirty feet in the row, by the quincunx plan, the rows become fifteen feet apart, and the tree approximately 21.25 feet from those nearest it. By this method the land is more fully occupied. It will be seen, however, that unless the rows are more than thirty feet apart, setting a tree in the center of the square would so reduce the distance between the rows that difficulty would be encountered in orchard operations. This system is most often employed at present where fillers are used.

The Alternate System is designed to correct the difficulties arising from the former. It differs from it essentially in widening the distance between rows, and is therefore better adapted to plantings under forty feet. The first tree of each of the even rows is midway between the first and second trees of the odd rows. The rows are placed far enough apart so that the diagonal distance between trees of adjoining rows is greater than the distance between trees in the row, and the perpendicular distance between rows is less than the distance between trees in the row. In the alternate plan with trees thirty feet apart in the row the rows can be placed much closer together without reducing the space between the trees in adjoining rows so much as to interfere with orchard operations. By this method, the number of trees per acre may be increased, the land better distributed among them, and inconvenience in orchard operations avoided.

The alternate system is frequently used in close plantings. In an orchard with rows twenty feet apart, set by the alternate system, it will be found much easier to get between the trees than if the rectangular system is employed, for the distance between the nearest trees of the adjoining row will be approximately twenty-two feet, four inches, or over two feet more than when set by the rectangular. Set at this distance the space between the trees of adjoining rows would be approximately the same as when planted thirty feet apart by the quincunx.

The Hexagonal System or equilateral triangle system, is rapidly gaining favor as the most economical system for planting orchards. It is an alternate system in which the perpendicular distance between the rows is such that the diagonal distance between the nearest trees of adjacent rows is equal to the distance between trees of the row. In

this system each tree is equidistant from the nearest neighbor in any direction. The land is equally distributed among the trees, and it is practically all used without crowding the trees. It also has the advantage of increasing the number of trees about fifteen per cent over the rectangular system without reducing the distance between trees.

The rectangular or square, alternate, and hexagonal systems are the ones which will be found to be best adapted to most conditions with the advantage largely in favor of the latter.

DISTANCE OF PLANTING

There is considerable controversy as to what is the proper distance between trees. It is impossible to give any hard and fast rule as to the proper distances as it will differ materially with climate and soil conditions, and the characteristic growth of the variety. There is always a tendency to plant trees too close. This is undoubtedly due to the fact that there is a desire to use as much of the land from the beginning as possible, and because newly set trees always have the appearance of being farther apart than necessary. Experience has proved that serious losses in the amount of fruit produced accompany close planting. Not only is the crop reduced, but orchard operations such as cultivation and spraying are interfered with in closely planted orchards.

TABLE No. 1. NUMBER OF TREES PER ACRE UNDER TWO SYSTEMS OF PLANTING

Distance apart each way	Number of Trees	
	Rectangular system	Hexagonal system
20 feet.....	108	124
25 feet.....	70	80
30 feet.....	48	55
33 feet.....	40	46
35 feet.....	35	40
40 feet.....	27	31

The Use of Fillers—As previously stated, there is a considerable area unused by the trees in a newly set orchard. One of the methods devised for using this area is to plant temporary or filler trees. These fillers are either earlier bearing varieties of the same kind of fruit or some other kind of fruit. The fillers are left until they begin to crowd the permanent trees, when they should be removed. The peach is largely used as fillers for apples in the East and South but is not sufficiently hardy for culture in the Central West and if fillers are to be used the American plum seems to be the only fruit available. Other fruits are sometimes used but not extensively.

There is another objection to fillers which makes their value questionable. Most growers leave the fillers so long before removing them

that the permanent trees are seriously injured. Perhaps that fault should not be charged to the system, but so long as it constantly occurs it needs to be considered. The grower should be confident that he is willing to remove trees producing good crops in order that all the trees may not be permanently injured. Fillers are not necessary for the utilization of the open area between newly set trees, and the writer believes that in most cases some other method will be found more advantageous.

LAYING OUT THE ORCHARD

Wire Method—There are numerous methods of laying out and staking land preparatory to orchard planting. One of the most convenient and efficient on small areas, which are comparatively level and set by the rectangular system, is the wire method. Stakes are set along two sides of the orchard beginning at the desired distance from the fence, usually fifteen to twenty-five feet, and then at intervals equal to the distance the rows are to be apart. In setting these stakes, care should be taken to begin at the same end for both rows and to have the distance between the stakes exact. A wire sufficiently long to reach across the field is then stretched between the corresponding stakes on opposite sides. Telephone wire or even smaller wire may be used. Number 14 wire has been used successfully on small areas. Fine wire or other markers should be fastened on the wire to mark the proper distance between the trees. The wire should also be provided with loops or rings at the end so that it may be kept well stretched. Small stakes are set at the points indicated by the markers, and the wire then moved over to the next stake at each end ready to mark the second row.

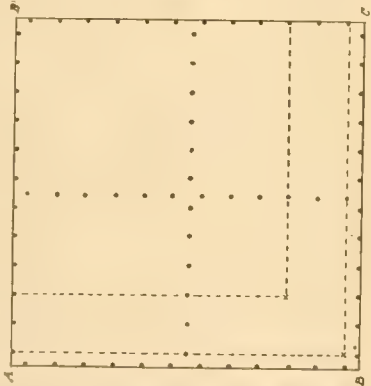

FIG. 4.—STAKE THE FIELD BEFORE PLANTING
By this method the stake is not placed where the tree is to be set but trees are easily located.

While designed for the rectangular system, this method can also be used in the hexagonal system by having the first marker of the even

TABLE No. 2. DISTANCE BETWEEN ROWS IN THE HEXAGONAL SYSTEM

Distance between trees	Approximate distance between rows
20 feet.....	17 feet, 4 inches
25 feet.....	21 feet, 8 inches
30 feet.....	26 feet
33 feet.....	28 feet, 7 inches
35 feet.....	30 feet, 4 inches
40 feet.....	3½ feet, 8 inches

numbered rows come half way between the first two trees of the preceding row, and by having the distance between the rows as shown in Table No. 2.

Lining-in Method—A method very commonly used in setting an orchard by the rectangular system is the “lining-in” method. Stakes are set on both sides and ends of the area to be planted. Laths serve the purpose very well. The first stake should be the proper distance from the fence and the others at intervals equal to the distance between the rows. Two rows of stakes are run through the center of the area at right angles to each other, care being taken not to have them come on the line of the row, which is easily done by starting between two of the stakes on the end. These stakes should be in line with the stakes running parallel to them. The man setting trees now has two stakes in each direction by which to line-in his trees. By this method all intermediate stakes and the planting board may be dispensed with. See Fig. 4.

Marking With the Plow—When large orchards are to be planted, the item of digging the holes for the trees is an expensive one. To reduce this to a minimum, marking out with a plow is a very good method. The method for staking is much the same as when the wire is used for locating the trees. The position of the first row should be determined and stakes set near each end. Each succeeding row is marked in like manner. If the ploughing is to be done in but one direction, the distance between the trees may be determined by one of the methods previously mentioned. When done in both directions, the other sides of the area should be staked out in the same way as the first two. It is usually found advantageous to have other stakes set in line between the end ones, particularly if the rows are long or the site rolling. With a steady team and good driver, the rows can be gotten reasonably straight, but it is always desirable when this method is used to be very careful in getting the trees of the first two rows and the first two trees of each succeeding row in exactly the right place, and then line in the other trees of the row. In doing this, working two men together will greatly facilitate planting.

Staking for Hexagonal System—One method has already been given for staking for the hexagonal system. Most methods which are used in laying out the orchard by the rectangular system can be employed in the hexagonal system if the following facts are taken into consideration. That in the hexagonal system the distance between the trees in the row are the same as in the rectangular system, but that the distance between the rows is less. (See Table No. 2). Also that the trees of the even numbered rows are midway between the trees of the odd rows. It would be more difficult to use the plow in two directions in planting by this system than by the rectangular.

Another method is frequently used in staking out the hexagonal orchard. The first row is located with reference to the fence and becomes the base line. Beginning at the desired position of the first tree, stakes are set at the desired distance between trees, a wire the length of the distance between trees is then used for the location of the remaining trees. It is convenient to have a ring at each end of the wire as this facilitates handling. If the rings are used the length of the wire should be considered as extending from center to center of the rings. One ring should be fitted with a marking pin, this end to be used by the man locating the position of the trees.

Method of Locating the Trees — In locating the trees A holds the center of his ring over the first stake of row 1, while B takes the marking end and strikes an arc at what he thinks is the location of the first tree of the next row. A walks to the second stake of the first row, and B again strikes an arc. At the intersection of these arcs he sets a stake, locating the position of the second tree will be. When all the trees of row 2 are located, it becomes the base line from which to locate trees of row 3. If the ground be uneven, a plumb bob should be used so that the wire may be kept horizontal. In locating the end tree there is frequently but one stake from which to strike an arc. The location is easily determined, however, by locating the second tree first, and then using it as the point from which the arc is struck. After four rows have been located by the arcs, others may be lined in.

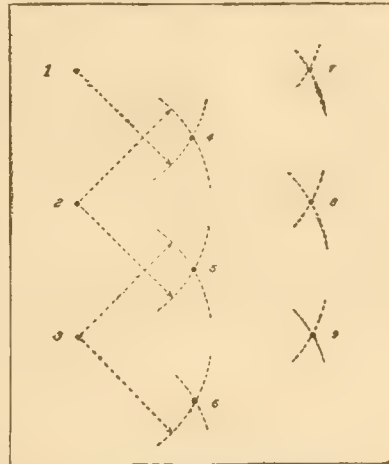

FIG. 5. A HEXAGONAL SYSTEM OF STAKING

Staking for the hexagonal system may be done by striking arcs of a circle with a wire compass

SELECTING TREES FOR PLANTING

Although nearly every person who buys fruit trees is particular as to the character of the tree which he buys, nevertheless, thousands of trees are planted every year which are not suitable for orchard purposes. That this condition should exist may be due to the combination of a number of causes. There are three, however, which will account for the planting of the greater portion of inferior trees.

Very frequently the buyer has no well defined idea as to what the tree should be. A second cause is that he does not state explicitly in his order just what kind of trees he wants. Even if he fulfills the first two requirements, he often fails to refuse stock which has been sent to him which does not come up to the specifications in his order. Even

though he knows that they are practically worthless he plants such trees simply because he does not care to take the trouble to make the nurseryman furnish him good goods or because of the delay that will be entailed.

The nurseryman is not always to blame because a buyer gets inferior trees. There are many things which make the filling of nursery orders difficult, but probably the chief reason why so many poor trees



Fig. 6.—Many growers fail in establishing their orchards by planting worthless trees. The trees on the left are of little value as no treatment can correct their faults. Make your order to the nursery very definite and refuse stock which does not conform to specifications.

Courtesy of the Wisconsin Experiment Station

are sent out from the nursery is because the average buyer is dissatisfied unless he gets a large tree with a heavy top. In his attempt to satisfy the demand for large trees, the nurseryman very frequently is obliged to sacrifice the very things which would make the tree most valuable.

Some buyers apparently think that all varieties grow alike, and having gotten an ideal in mind, want all trees to come up to that ideal. Such a thing is impossible. A Fameuse tree will not grow like a Northwestern, any more than a Jersey cow will resemble a Shorthorn, but because it will not do so does not mean that it is inferior to the North-

western. The first thing the buyer must have in mind is what the ideal for the variety is, and then judge his trees accordingly. There are some general requisites, however, which can be considered in common.

Age of Trees for Planting — Unfortunately, nursery trees are commonly sold by size rather than age. Size is not necessarily a criterion of the worth of a nursery tree. In fact, it is a worthless factor in judging unless considered in connection with age. A six foot tree may be four or five years old, but it would be a much poorer tree than one of the same variety four feet high and three years old. A great many trees are being carried in the nursery until they are long past the best age for planting, simply to get them to a large size. This is particularly true of slow growing varieties.

The true standard then, for buying trees is the age. In this, of course, size should be considered to the extent that the trees should be of good size for the variety at that age. A two-year-old Fameuse then would probably be much smaller than a two-year-old Duchess or Northwestern.

How to Determine Age of Trees — It is very easy to determine the age of a nursery tree. The age is counted from the budding or grafting. The end of each year's growth is marked by a row of rings or scars around the trunk and branches. To tell the age of a tree, begin at the tip of a branch and follow back to the base of the tree counting the scale rings. The tree will be one year older than the number of rings. It is best to use the branches at the top. In trees on which the tips of the branches have been injured or removed, during the summer, some difficulty may be experienced in determining definitely, but this method will serve in most cases without difficulty.

The best age at which to plant trees is a much mooted question. The tendency has been to plant trees which are too old. The upper limit of age for an apple tree is three years. Two-year-old trees will be found better than older ones in most cases. Commercial orchardists plant mostly one-year-old apple or pear trees. Plums and cherries are set at one or two years and peaches mostly at one. The present demand for large trees causes the nurseryman to prune off the side branches along the first and second year's growth, thus in a great many instances spoiling the shape of the tree or at least making it necessary to form the head too high.

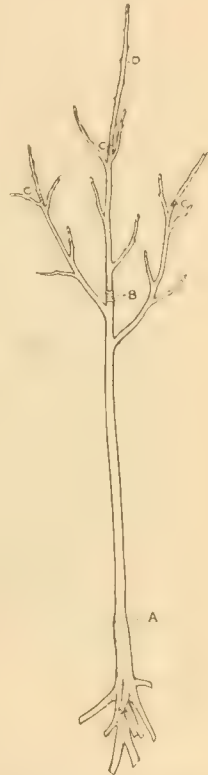

Fig. 7.—To be certain your trees are not too old, determine their age by counting their bud scars. The union of the stock and scion is shown at A; the end of the first year's growth at B; the end of the second year's growth at three points, C, C, C; and the three years' growth at D. A scale ring is shown at B.

Another factor which tends to give inferior trees where they remain long in the nursery is the fact that they are grown very close together, and this forces the branches to grow more in one plane which results in ill-shaped trees. The shorter the period the tree passes in the nursery, the more likely it is to be a good tree when the grower receives it.

It is true the younger trees require longer to come into bearing after being planted, but the orchardist can better afford to give them one or two additional years' attention and have the opportunity to prune and care for them so they will make first class trees, than to let the nurseryman grow them for the additional length of time, and have to give the



Fig. 8.—Low-headed trees are best as orchard operations are easier. Eighteen inches to two feet to the first branches sufficiently high with most varieties. Low heads can only be secured when low-headed stock is planted.

Courtesy of the Wisconsin Experiment Station.

same amount of care later on in trying to change a spoiled tree into a passably good one. It is not the intention to convey the idea that no good three-year-old trees are produced in the nursery, but with the present systems and practices the chances are very much against it.

Best Height of Head — By “height of head” is meant the distance between the base of the tree, after planting, and the height at which the main branches grow out. Formerly trees with branches lower than five or six feet were not desired because when lower they were supposed to be very difficult to work under. Today no good commercial orchardist would think of planting trees with such high heads. There are numerous reasons why a low-headed is preferable to a high-headed tree, but the chief one is because it facilitates orchard operations.

In this day of pruning and spraying and high prices for labor in picking, the orchardist does not want a tree so headed that it will require a ladder to reach the lowest branches producing fruit. The old objection that the lower branches of low-headed trees interfere with orchard cultivation is easily met by the fact that a great many trees have a habit of growth which permits work under their branches even when low-headed without additional inconvenience. Those which do not have such a habit can be improved by proper pruning, and the head need be only a little higher than in the others. The low headed tree, therefore, is rapidly becoming the only one used in commercial planting. Improved orchard tools makes it possible to cultivate the soil even under trees with very low heads.

The question is often asked, "What is the proper height to head a tree?" Authorities differ, some giving one foot as the desired height, others as much as three feet. It is scarcely wise to make any hard and fast rule as the height which will be found most advantageous will vary with different varieties. For upright growing varieties of apples like Wealthy and Northwestern, eighteen inches to two feet will be sufficient. Varieties like Longfield with a spreading habit and slender branches should be headed somewhat higher. Pears are upright in growth and should be headed low—often not over one foot. Peaches are usually headed lower than apples, European plums about the same as peaches and native plums a little higher.

Distribution and Number of Branches

—With trees more than one year old, the proper distribution of the main branches is one of the most important things to consider. As already stated, closeness of planting in the nursery row frequently causes all the branches to form on two sides of the tree, or to become so curved that when set in the orchard there are branches only on two sides. Good trees can seldom be formed from these trees. The branches should be well distributed around the trunk, and sufficient in number so that if any form V-shaped crotches, they may be removed. Usually four to five branches will be sufficient from which to select the foundation for the head of the tree. These branches should be good, strong ones. Frequently a nursery tree has only small slender branches arising from the trunk at the height desired for forming the head. This is usually due to improper pruning in the nursery row. Such trees are not first class and should be refused.



Fig. 9.—This tree is headed too high. Courtesy of the Wisconsin Experiment Station.

POINTERS IN ORDERING NURSERY STOCK

Deal Directly with the Nurseryman—Three-fourths of the trouble which arises over tree purchases could be avoided by ordering directly from the nurseryman rather than through a nursery agent. It is unwise to order nursery stock from an agent unless you are acquainted with him. In the first place, a great many agents "work" a territory but once, and their only aim is to sell as many high-priced trees as possible, therefore they will recommend any variety whether it is

adapted to prevailing conditions or not. Almost invariably they will push the "novelties" which are high-priced, and which later turn out to be worthless. It is usually a good practice to let some one else try out the new sorts.

Not a few nursery agents are mere "confidence" men. In some instances they claim to represent a reputable nursery firm when they have no connection with it whatever. Many purchasers of trees have been practically swindled by signing contracts presented by unknown nursery agents.

Where any considerable number of trees are to be purchased, there are other reasons than those given above for dealing directly with the nurseryman. The agent has a set order to be filled out which gives the number, kind and size of trees wanted. It says nothing whatever about the height of the head, number of branches and age of the trees, which are quite as important as the items which it enumerates. When you order directly from the nurseryman you are able to get these items in the order, with the result that if the nurseryman values your future orders you will usually get better stock because he knows exactly what you consider first class stock. In the other case he would have no idea concerning your preferences.

State Character of the Trees Desired—As has been suggested above, this is one of the most important essentials in ordering stock. One-year-old trees are bought by size. With older stock it is not necessary to state the exact size of tree, but it is important to give the age. The order for apple trees should read about as follows: "Trees two years old, typical of variety; of good size for age; heads not over 24 inches high (somewhat higher in spreading varieties), four to six well distributed branches; free from pests or serious blemish."

When such an order is given, refuse goods which are not up to the standard. It is a waste of time and money to set inferior trees and attempt to make them desirable later on. This usually results in putting up with an inferior tree and very frequently, in commercial planting, of the removal and replacing of the tree later on. If you make it sufficiently clear in your order that nothing but first class trees will be accepted, there is usually very little difficulty over inferior stock.

Refuse Substitutions—Nearly every nurseryman retains the right of substitution on his regular order. When you sign the order blank presented by the nursery agent you endorse a clause essentially as follows: "In case the supply of any variety has been exhausted, we retain the right to substitute a similar variety of our choosing." In ordering from the agent be sure that on your order there appears "No substitution allowed." If this is done, no dispute can arise over substituted stock. In ordering directly it is not usually necessary to make this statement, but it does no harm and is a wise precaution.

Keep a Copy of the Order—While a mere detail, keeping a copy of the original order is important as it often saves disputes and frequently more serious trouble. Not only should the order be preserved, but all correspondence relative to the transaction as well. Occasionally the fruit grower overlooks the importance of this precaution and pays dearly for his neglect.

Be Willing to Pay a Good Price — It is a very serious mistake to try to cut the cost of the trees too much. Cheap trees are usually poor trees. It is not necessary to pay exorbitant prices in order to get good trees, but it is better to pay exorbitant prices and get good trees than to buy poor trees at cut rates. The original cost of the tree is of minor importance to its ultimate value. Ten or even twenty-five cents saved at the start by buying an inferior tree is usually expended several times later on in trying to make a good tree out of a cull, and usually with very little success. Paying a high price for a tree does not necessarily mean that it will be a good one. Pay enough to get the best and then refuse any which do not come up to the standard.

Another item which increases the cost is replacing stock. The general practice of some nurserymen is to replace stock which dies the first season. In order to do this they add considerable to the real price of the tree in order that nothing will be lost by replacing. Such a practice invites carelessness in handling and setting the trees. In addition, it works a hardship on the careful man because he is compelled to help pay the cost of his neighbor's carelessness. Almost always the grower will find it worth while to carry his own risks if he orders good trees and is careful in planting them. In writing for quotations on trees he should state that he does not want his trees "guaranteed," and the nurseryman will make a considerable reduction from his regular price. Many nurseries do not "replace" stock which dies the first year, and this should be taken into consideration in comparing prices with those quoted in the catalogues of nurseries which give a guarantee.

CARE OF TREES ON ARRIVAL

Very often trees arrive before local conditions permit of their being planted. It is a serious mistake to leave trees for any considerable period in the packages in which they arrive. Not infrequently trees which arrive in good condition are allowed to remain in the package several days with the result that when they are taken out they are seriously injured if not rendered entirely worthless.

The object should be to get the tree into the soil as soon after its arrival as possible. If it cannot be planted, it should be "heeled-in." Select, if possible, a protected place as on the north side of a building or fence. If a large area is to be planted it will be found convenient to heel-in the various varieties along the side of the area near their location in the planting. If

the trees are in small bundles and are to remain only a few days the bundle will not need to be opened, although the work is facilitated if this is done.

Dig a trench about eighteen inches deep, one side slanting at an angle of about thirty to forty-five degrees, depending upon the amount of protection desired of the branches. Place roots of the trees in this trench and cover with earth, packing it down so that all the roots are in contact with the soil but not tight enough to break the roots. If one trench is insufficient to hold all the trees, take the earth from the side of the trench opposite the tops. In this way a trench for the second lot of trees is dug without additional labor. Where several varieties are to be heeled-in in the same place, it is a good plan to put one variety in each trench as this



FIG. 10 — "HEELING-IN" NURSERY STOCK

"Heeling-in" keeps the roots moist, insuring growth when the trees are planted in the field.

Courtesy of the Wisconsin Experiment Station

insures keeping the varieties separate without relabelling all the trees. If trees are heeled-in in the open where exposed to the sun the tops should be placed towards the south and the angle with the ground increased so as to give the trunks more protection. Properly heeled-in trees may be left for reasonably long periods without injury.

Time for Planting — Trees are planted either in fall or spring. In those sections where there is little or no danger from severe injury to newly planted trees due to unfavorable climatic conditions during the winter, fall planting has several advantages. Low degrees of temperature accompanied by high drying winds often cause serious losses to newly planted trees, as they are in the poorest possible condition to

resist the drying effect which results. Growers in regions where such conditions exist had best defer planting until spring. Trees should be planted as early in the spring as soil and climatic conditions will permit. If, for any reason, planting has been delayed, it can be done well into May, particularly if the trees have been carried in a storage cellar and are in dormant condition. Trees may be set when in leaf, but this is far less satisfactory than when they are dormant.

SETTING THE TREES

There are several items which need careful attention in setting the tree. One of the very first is getting the tree in the proper position. In many of the systems of laying out an orchard a stake is set to mark the location of the tree. As the stake is removed to dig the hole, difficulty arises in getting the tree in the position occupied by the stake, as very frequently the root system of the tree is such that the hole cannot be dug symmetrically. To obviate this difficulty the planting board is employed. There are two forms of planting boards commonly used. The more common one is made from a piece of board

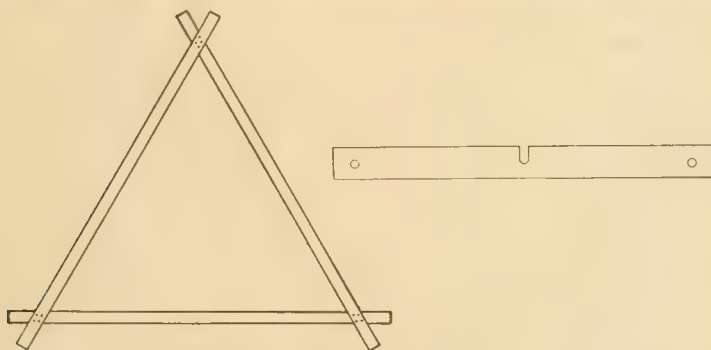

FIG. 11.—SIMPLE FORMS OF PLANTING BOARDS

The central notch is placed around the stake, two stakes are then driven in the other holes or at the corners of the triangle, then the stake is removed, the hole dug and the tree set so that it stands in the point formerly occupied by the original stake.

about six feet long and six inches wide. A notch is cut in one side at the center and a hole bored at equal distances near either end. These holes are provided with wooden pins. The notch of the planting board is placed over the stake locating the tree and the pins stuck in the ground through the holes in the ends. The board and stake may then be removed and the hole dug. Replacing the board over the pins shows the exact location of the tree. Another form of planting board is the equilateral triangle. Three laths or narrow pieces of lumber are fastened together so that they form a triangle with the ends projecting as shown in Fig. 11. Care should be taken to have the distance between each two adjoining corners equal, as this will relieve the necessity of replacing the triangle in the same position. One projecting end is put over the tree stake and the pins placed in the others. This marks the location of the tree after digging the hole the same as with the former.

Size of Hole for Planting—The size of the hole for the tree depends upon three factors—extent of the root system, character of the soil and height of heading. The size of the hole in relation to the extent of the root system varies from that made by the crowbar, as used in the "String-fellow" system of planting to two feet or more square. Under normal conditions the size of the hole should be such as will conveniently admit the root system without crowding. In most cases this will be about fifteen to eighteen inches square. As a usual thing the root system should not be reduced just to make it go into the hole even though this is the easier and quicker method.

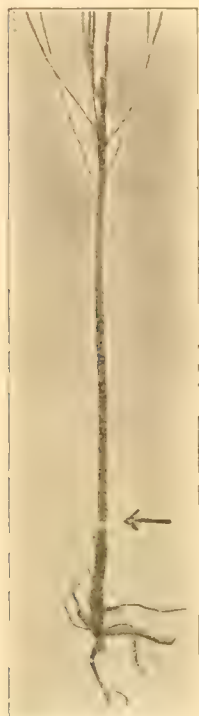

Fig. 12—Set trees slightly deeper than they stood in the nursery row. Three to six inches is generally sufficient.

Courtesy of the Wisconsin Experiment Station

Where the soil is heavy and compact and has not been put in proper condition of tilth prior to planting, the hole should be considerably larger. In this way the soil in the bottom of the hole may be loosened as well as that at the sides of the hole and the root system given a better chance to develop.

With normal soil conditions the depth will be largely influenced by the height of the head, although there are other influencing factors. The general rule is to set the tree somewhat deeper than it was in the nursery. Horticulturists differ as to the best depth for planting, but usually advise from three to five inches deeper than in the nursery. Root grafted trees should be set low enough so that the union of the stock and scion comes some distance below the surface.

Where one desires low-headed trees, and has been unable to secure them, the height of the head may be somewhat reduced by deep planting. If this is done, however, it should not be carried to extremes even if necessary to sacrifice something in height of head. It is probably not best to set trees much if any over eight inches deeper than they were in the nursery. Roots placed too far below the surface are unable to perform their function as well as if nearer the top of the ground.

The use of dynamite in planting trees has recently been brought prominently before orchardists. It undoubtedly gives beneficial results and lessens labor on locations with hard or impervious subsoils. On soils in good tilth and having fairly loose, open subsoil it is doubtful if its use will give results sufficient to offset the cost of material and labor entailed.

Root Pruning—Root pruning is essential to the best results in planting trees. As a rule, more than enough of the root system has been

removed by the nurseryman in digging and so farther reduction is not desirable from that standpoint alone. Injury in digging and shipping, however, makes slight root pruning before planting desirable. The object should be to put the root system in good shape with the slightest amount of removal possible. Practically no attention need be given the small roots. The ends of the large ones, however, will demand attention as the wounds in digging are left rough and splintered. The ends of the roots should be cut back to secure smooth wounds which facilitate healing. Badly broken or split roots should be removed. Exceedingly long roots may be shortened.

Root Distribution—The roots should be as well distributed around the tree in planting as possible. Frequently they are practically all on one side, and under such conditions it is difficult if not impossible to have them properly distributed. In such cases care should be taken to have the greater part of the roots on the side on which they will give the greatest support to the tree. The chief thing to consider will be the prevailing wind. Where the prevailing wind is from the west or southwest the strongest roots will usually extend in that direction.

Slant of Tree in Planting—It is usually a good practice to slant the tree more or less when planting. The amount of inclination varies in different sections, depending mainly upon exposure to high winds. The writer has seen young trees inclined twenty degrees from the perpendicular when planted that were perpendicular when they reached the bearing age. Slant-



Fig. 13.—In regions of high winds plant the trees with the top leaning toward the wind, as shown above. On hillsides lean the tree up hill. Courtesy of the Wisconsin Experiment Station.

ing at an angle of eight or ten degrees will usually suffice. Not only does this inclination help prevent the trees from becoming uprooted, but it also aids in protecting the trunk against sun scald. On hilly sites the trees should be inclined up hill even though the wind be from the opposite direction. In the latter case, however, the inclination will be less than if the site is protected from heavy winds.

Filling the Hole—A great many newly planted trees die because of carelessness in filling the hole. It is important that this work be done carefully. If the soil which was removed from the bottom of the excavation be hard and lumpy it should be placed to one side and the surface soil used first in filling. The main thing to remember in filling is that every part of the root system should be in contact with the soil. Unless it is, the exposed areas

will be points for the loss of moisture and the drying out of the roots. The soil surrounding the roots must be fine if they are to be well covered. Either loosen the soil in the bottom of the hole or throw in two or three spadefuls of loose earth so that when the tree is put in it will sink sufficiently into the soil that all under surfaces will be in good contact with it.

The soil may then be filled in, using the fine soil first and compacting it well around the roots. There is little danger of compacting the soil too much unless it be of a clayey nature, and somewhat moist. After the first few spadefuls have been put in the soil may be packed by tramping. Be careful in compacting the soil not to crowd the tree out of place. The soil should be mounded at the base of the tree above the natural level of the land, the top two inches being left loose and fine.

Avoid Fertilizing Young Trees—It is a common practice to fertilize newly set trees with yard or stable manure. This practice should not be followed. The first activity of a newly set tree should be to develop an extensive root system. If large amounts of plant food materials be placed within easy reach of the tree, the root system will be confined to a comparatively small area. The roots will not develop sufficiently to secure enough food to keep up a normal growth of the young tree, after the supply of food materials provided at planting have become exhausted, and what was gained at the beginning will be more than lost by the check which the tree receives.

Watering Benefits Little—Under normal conditions, little if any benefit is derived by watering newly set trees. In the first place, enough water seldom is applied to moisten the soil around the roots. If water is to be given it should be applied in quantities sufficient to nearly saturate the soil to some little depth below the bottom of the roots. Another mistake which is usually made is in applying the water on the surface after the hole has been entirely filled. If water is to be applied, it should be either put on before the top two or three inches of soil are filled in, or if applied to the surface as soon as the soil is sufficiently dry, the surface soil to a depth of two inches should be cultivated and put in fine tilth. Growers frequently "puddle" the roots before planting. This is done by dipping them in a thin mud. The mud forms a thin coating of earth over the roots helping to prevent the loss of moisture.

Litter Mulching Gives Slight Benefit—Practically the same objections which have been raised against watering can be offered against mulching. It is expensive, and as a rule, not enough mulch is applied to be of any material benefit. Frequently stable manure is used, and this adds to the objections of the practice. Mulching, as it is commonly understood, means putting litter of some kind around the base of the tree for the purpose of conserving the moisture and protecting the roots from too much heat transmitted through the soil. The most efficient and least expensive mulch for this purpose is not one of litter, but one obtained

by keeping the surface soil around the base of the trees in good tilth. If kept fine and loose the dust mulch is more efficient in conserving moisture than the litter mulch, and retains the moisture at the point where it is needed rather than at the surface of the soil, as does the litter mulch.

TOP-PRUNING YOUNG TREES

Probably more trees die the first season after planting from lack of proper top-pruning than from any other one cause. One frequently sees newly set trees in which the top has been left exactly as it came from the nursery, or at most, only a small amount of the growth removed. Scarcely, if ever, does the grower prune his trees too severely at setting; in almost all cases not enough is removed.

Top-pruning should be done just as soon after planting as possible, as every day it is neglected lessens the chances for the tree to withstand the adverse conditions. There are two reasons why top-pruning immediately following planting is of so great importance. First, it is the means of equalizing the root and top area; second, it is the most important pruning, as a rule, in the formation of the head of the tree if the tree is more than one year old or a branched one year tree.

As has been previously stated, when a tree is dug not only is the root system mutilated, but by far the greater portion is removed. Often four-fifths of the root area is left in the nursery. It is readily seen then that if the top of the tree is not reduced, this mutilated and greatly lessened root area is called upon to supply as much top with moisture and food materials as the entire root system did previously. If the roots have not been too greatly reduced, and conditions are favorable, the tree may succeed in getting through the first season, but seldom in first-class condition. The moisture supply is insufficient, the tips of the branches dry up and die, and not infrequently the bark of the entire top becomes more or less shriveled, which is a clear indication that the tree is being severely injured. If the tops had been reduced the moisture and food now going to numerous branches would have been supplied to a few and these injurious results largely, if not entirely, avoided. Very often where no top-pruning is practised, and climatic and soil conditions are adverse, the tree dies without putting out any new growth. It is evident then that fruit trees should be heavily top-pruned immediately after planting.

But of slightly less importance in pruning after planting is the forming of the head of the tree and the selection of the branches which are to be the foundation for the top. No absolute rules can be given for pruning for this purpose, because each tree offers a different set of conditions. A few general suggestions will help determine the extent of cutting back.

In pruning one-year-old whips all that is necessary is to cut off the tops sufficiently high to bring the head at the proper height after allowing from twelve to eighteen inches for distribution of the branches. In older stock it is not always possible to secure the head at the desired height, but if the directions under "Ordering Nursery Stock" are followed but little difficulty will be experienced in this regard. Sometimes it is necessary to remove better branches to secure the desired head than

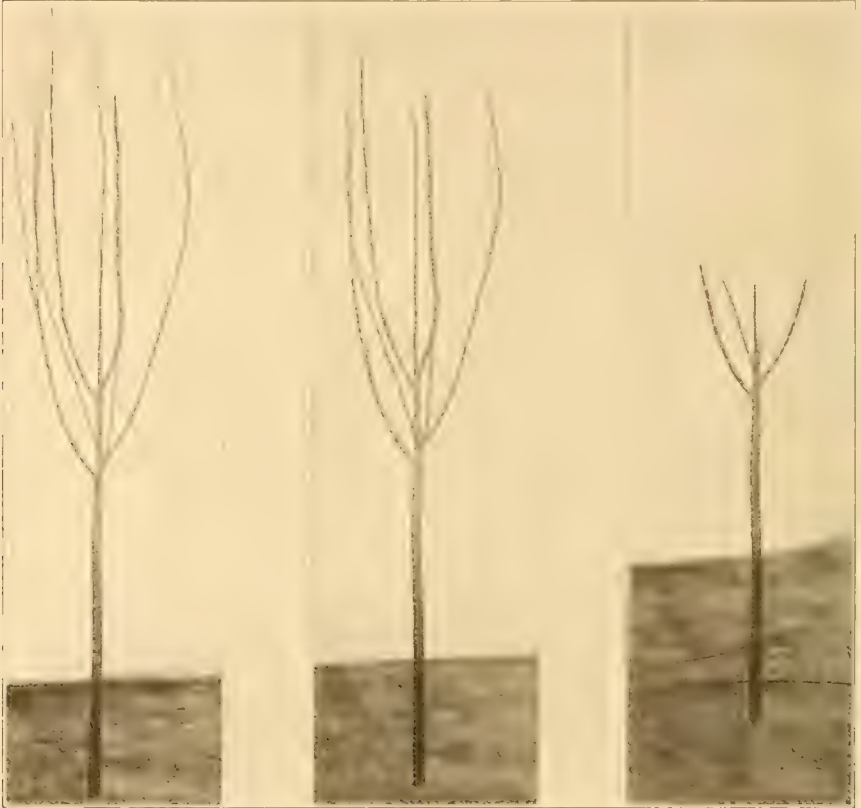

FIG. 14. EXAMPLES OF POOR AND GOOD PRUNING

The top of a young tree should be pruned immediately after planting. Most orchardists do not prune enough. On the left is shown the tree, as received from the nursery, in the center the ordinary but insufficient pruning, while on the right it is shown properly pruned.
Courtesy of the Wisconsin Experiment Station.

some which are to be left, but if those left are average then the lower heading is to be preferred. The number of branches to be left and their position depends somewhat on the character of the top desired. There are two forms of tops used: the open or vase form and the closed centered. In the North, with its short growing season, the open centered form is most desirable. This means that in pruning the central leader or the branch making the upright growth from the center should be cut out.

Too many main branches are usually left. The proper number varies

somewhat with the kind of fruit. In pruning the apple four are sufficient and frequently three on strong growing trees will be enough to give a good top. With the cherry, plum and peach the number may be somewhat greater, although even with these fruits the number should be kept small. If too many branches are left at the start the top becomes too thick, necessitating the removal of one or more later on. This can seldom be done after the second year's growth without injury to the form of the tree. The removal of a large branch after this period leaves a hole in the side of the tree which is difficult to fill. Had the branch been removed in the first pruning the others would have filled in the space and the tree would have been symmetrical.

The branches which are chosen should be as nearly equally distributed around the tree as possible. If they are unevenly distributed and the space wide they should be so pruned as to throw the growth from the top bud of each of the adjoining branches into the vacant space. Avoid having the branches come out from the trunk too close together. They can extend along the trunk for eighteen inches, and although they may appear spaced too far at first, when the tree has reached the bearing age, and the branches have developed, they will be close enough together. Choosing branches which arise at practically the same height gives bad crotches which are liable to become sources of trouble later on. Avoid as much as possible V-shaped crotches. They are weak and the branches are very likely to split down under high winds or heavy loads of fruit. Some varieties are prone to this form of crotch and therefore should be given extra attention in this respect. Pruning one-year-old whips the season following planting is identical with that for two-year-old stock at planting.

Cutting Back the Top—No point in top-pruning after planting is more discussed and disagreed upon than the extent of cutting back of the branches chosen for the foundation of the head. All agree that they should be cut back somewhat in order that the new branches may be forced out nearer the head of the tree. If not cut back the buds near the tips of the branches will produce the strongest growths, but they will be so far from the head that if left, the branches will be more likely to break down under heavy fruiting. The main branches are usually cut back, leaving them from six to eighteen inches long. Eighteen inches is the maximum length under normal conditions, and there is little doubt that in most cases twelve inches would be a better maximum than the greater length. The branches of cherries, and especially of peaches are frequently pruned back to spurs four to six inches long.

Do not cut back beyond the last season's growth in cutting back the branches unless the previous season's growth has good, strong buds from which to produce new shoots. Good, strong, main branches seldom arise from side shoots on two-year-old wood, and in forming the head of the tree such a practice will usually result disastrously.



THOROUGH CULTIVATION IS AS ESSENTIAL TO THE BEST ORCHARD MANAGEMENT AS IN THE PRODUCTION OF A CROP OF CORN

Courtesy of the Wisconsin Experiment Station

CHAPTER IV.

THE MANAGEMENT OF A BEARING ORCHARD

- I. HANDLING THE ORCHARD SOIL. II. SOIL MANAGEMENT OF BEARING ORCHARDS—AS A PASTURE—AS A HAY OR GRAIN FIELD—THE SOD MULCH—THE HALF-SOD MULCH—THE CLEAN-CULTURE-COVER-CROP-SYSTEM—WHEN TO SOW CROPS—COVER CROPS AS PLANT FOOD SUPPLIES—HARDY AND NON-HARDY COVER CROPS—AMOUNT OF SEED FOR COVER CROPS. III. SOIL CARE IN THE YOUNG ORCHARD. IV. FERTILIZATION OF THE ORCHARD. V. PRUNING THE BEARING ORCHARD.—THE TIME TO PRUNE—SECOND SEASON'S PRUNING—THIRD YEAR PRUNING. VI. PRUNING NEGLECTED TREES—SPASMODIC PRUNING. VII. WOUNDS, THEIR MAKING AND TREATMENT. VIII. SPRAYING.

Handling the Orchard Soil—The question of soil management in the orchard is one of great importance if the greatest possible returns are to be obtained. Too often the man who plants an orchard gives considerable thought to selecting the site with reference to best soil conditions, but lets his concern of the soil stop with the planting. Orchardists are beginning to realize more and more that the matter of handling the orchard soil properly ranks in importance with spraying, pruning and other orchard operations. While it is not possible to make hard and fast rules concerning

orchard soil management on account of widely varying conditions, it is possible to point out the evils of some of the methods now in use and indicate those which will be found best under average conditions.

Several possible ways of handling the orchard soils present themselves. Before discussing these it is well to consider in what respect fruit production differs from the production of other crops. The most apparent difference is that orchard cropping is continuous cropping: that while with corn and wheat there is a chance for rotation, with the apple the same crop is being produced from year to year, which means that the same food materials are being demanded each year in the same proportion. We know that continuous cropping is the quickest method of depleting soil fertility. In the orchard, rotation is impossible, therefore the orchardist should even be more alert concerning the preservation of soil fertility than the grain farmer.

The fact that a tree fruit crop is a two season crop is another factor which enters into consideration of orchard soil management. The question of winter killing is the reason why certain practices are necessary if injury is to be avoided. When one considers these facts, it is quite evident that orchard soils deserve more attention than has been given them in the past.

The orchard presents two distinct periods as to soil management: (1) from planting to bearing, and (2) after bearing has begun.

SOIL MANAGEMENT OF BEARING ORCHARDS

The Orchard as a Pasture—Pasturing the orchard is probably the most common method of solving the orchard soil question. While it is better than some of the other methods employed, so far as soil fertility is concerned, nevertheless it is a practice which should be discouraged. In the first place, it does not increase the fertility of the soil as commonly supposed, but rather robs it unless the animals pastured are receiving other feed than that secured from the grass. Unless animals are grain fed and fully matured, the plant food materials removed usually exceed those returned to the soil through the manure.

Not only is the soil robbed, but very frequently the trees are seriously injured if not entirely ruined. We have seen apple trees six inches in diameter with the bark torn off by hogs which were pastured in the orchard. Horses and cows do damage by rubbing against the branches, breaking them, and knocking off the fruit as well as browsing on the trees.

The Orchard as a Hay or Grain Field—The second most common use of the orchard is as a hay or grain field. This practice cannot be too severely criticised. It is nothing more nor less than an attempt to double crop an area with the result that neither is a success. It is practically impossible to grow a crop of marketable fruit without spray-

ing several times during the growing season, and this would be ruinous to the grain. As the result, no spraying is done and the fruit is wormy and scabby and often entirely unfit for the market. The trees also suffer, for they demand the moisture and available food materials just when the crop is making the largest demands.

The crop is not a success, for the trees shade a considerable portion and take so much moisture that it fails to develop, resulting only in a partial crop. The cost of seeding and harvesting is greater than where there are no trees to interfere. This is not successful orcharding, or successful grain growing; it is soil robbery. Either give up the orchard or quit using it as a place to produce hay or grain. That some horti-



FIG. 1—A NEGLECTED ORCHARD

Profitable crops of fruit cannot be expected in an orchard left to take care of itself. Soil management, pruning and spraying are necessary.

Courtesy of the Wisconsin Experiment Station.

culturists recommend the sod-mulch is no argument for such a practice, for this is not what is meant by a sod-mulch system.

The Sod-Mulch—The Hitchings or sod-mulch system of orchard soil management has attracted considerable attention during the past few years, and has been the basis for considerable experimental work. The sod-mulch system needs to be explained to many fruit growers and farmers who go into fruit growing, because they confuse cropping to hay with sod-mulch. In the sod-mulch system nothing is removed from the orchard. All grass is cut and left where it falls or is gathered and piled around the base of the trees. More recently it has come to include the hauling of additional litter and piling around the trees. Its advocates claim many advantages for it, while its opponents point out some

evils. Undoubtedly the sod-mulch system has some merits. As a means of conserving and controlling moisture, however, it is less satisfactory than the clean-culture-cover-crop system, and in several other respects is inferior to the latter method of orchard soil management.

The sod-mulch does have its place in apple growing. On rolling sites where the slopes are so steep that washing of cultivated soils entails danger from serious soil washing, the sod-mulch will be found a successful method of meeting the situation.

The Half-Sod-Mulch—The half-sod-mulch is a combination of the sod-mulch and clean-culture-cover-crop system. It is used by those who prefer cultivation to the sod-mulch, but whose sites are too steep to permit of cultivating the entire area. A strip of sod four to six feet wide is left along the row, and running as nearly as possible at right angles to the direction of the flow of water. When the trees are young the sod strip is best left between the rows. These sod-areas are handled the same as in the sod-mulch, while the space between is cultivated during the early part of the season and receives a cover crop later on. The advantages of the system are that it prevents washing and at the same time gives practically all the advantages of the clean-culture-cover-crop system.

The Definite Mulch — The definite mulch system as defined by its advocates is a system which varies chiefly from the sod mulch in two respects. Enough litter is placed around the trees in addition to that produced in the orchard to keep down any growth of weeds or grass which might otherwise grow there. The mulching material produced in the orchard instead of being ordinary grasses may be leguminous or other special grain crops sown for the purpose.

The advantage which it is claimed the definite mulch possesses over other forms of orchard soil management is that it is most efficient method of conserving soil moisture. This causes a later growth during the summer. This late growth may or may not be an advantage, and in choosing between various systems, one should consider very carefully whether a system which induces it is adaptable to the conditions under which the tree is to be grown. One of the greatest drawbacks to the system is the difficulty and cost of securing sufficient mulching material to provide the desired amount of mulch.

The Clean-Culture-Cover-Crop System—This system has come to be considered by a large majority of fruit growers as the best for orchard soil management. It consists in keeping the orchard under cultivation during the first part of the growing season, then sowing some crop which remains on the ground over winter.

The orchard is plowed in the spring to turn under the cover crop of the previous year. In irrigated sections it is probably best plowed under in the autumn. If the orchard has been under cultivation from the first there

will be no danger of injury to the roots. If, however, the orchard has been neglected or has been in sod for some time, the first plowing should be shallow and the later ones slightly deeper each time until the desired depth is reached. The orchard does not need to be plowed as deep as though a field crop was to be grown upon it. As the base of the trees is approached the plow should be run more shallow. It is usually more convenient to use only one horse in turning the last two or three furrows next to the tree. This permits getting much closer to the tree without so much danger of injury. Using a short whiffletree either with leather ends or having the ends covered with burlap protects the trees from barking.

All the soil possible should be turned and that which cannot be reached with the plow conveniently should be stirred with the cultivator later on. At times when the cover crop leaves but little vegetable matter on the soil in the spring, or when it is well decayed by time for beginning cultivation, the cut-away or disk harrow may be substituted for the plow.

Plowing or disking is best followed by harrowing. The number of times the orchard should be harrowed depends somewhat upon local conditions. After putting the soil in good tilth following the plowing, the orchard should be harrowed at least every two weeks. The object to be attained in this cultivation is to keep a good dust mulch on the surface to conserve the moisture and incidentally to keep down the weeds.

Harrowing should follow each rain as soon as the soil is sufficiently dry to work. Not only does this help conserve the moisture from the rain, but if the dust mulch which has been destroyed is not replaced not only that which has recently fallen but also additional amounts previously held in the soil will be speedily lost. Cultivation is valuable during periods of drought. Many growers believe that because no rain has fallen since the last cultivation that it is a waste of time to harrow again. Repeated moisture determinations made during a period of drought on soils frequently cultivated, and on others uncultivated but in all other respects similar, show that the cultivated areas retained much more moisture than the uncultivated.

Cultivation of the orchard soil is not only valuable as a means of conserving moisture, but it hastens the availability of food materials in the soil and provides for good aeration, both of which are of so great importance. "Remember that cultivation is essentially manure." This quotation from the late Dr. Kedzie is indicative of the value of cultivation as a factor in the availability of plant food.

When to Sow Cover Crops—The time at which cultivation shall cease and the cover crop be sown is very largely a matter of judgment. It depends almost entirely upon what soil moisture conditions are during the latter part of July, and what they are likely to be during the remainder of the season. One of the chief objects of the cover crop is to assist in controlling the moisture content of the soil during late summer and early fall. If there are large amounts of moisture in the soil during this period,

there is danger of new wood development continuing so long that it goes into winter only partially matured, and is very likely to winter kill. On the other hand reducing the quantity of moisture in the soil tends to hasten maturity and avoid unfavorable conditions.

It will be seen then that in a season in which there is heavy rainfall, or probability of heavy rainfall during August and September, that a rapidly growing cover crop becomes an effective means of reducing the moisture content of the soil. In seasons of drought, the cover crop will make proportionately less growth and not prove injurious to the trees. In wet seasons the cover crop should be sown comparatively early; in dry seasons, rather later sowing is best. As a usual thing it is sown between July 15 and August 1. In a season of drought during the early part of the season the probabilities of late growth are quite as great as



FIG. 2.—A COVER CROP IN THE ORCHARD

Cover crops should replace clean cultivation about mid-season.

Courtesy of the Wisconsin Experiment Station.

when June and July have been rainy months. It is well, therefore, to have the seed in the ground ready to begin growth as soon as soil moisture conditions will permit.

Another important function of the cover crop is to add vegetable matter to the soil. Without the cover crop the orchard soil would soon become depleted of its vegetable matter which would destroy its tilth and make the plant food much less readily available, unless considerable quantities of barnyard manure are applied. An ideal cover crop then should produce considerable vegetable matter. In order to do this the importance of having it ready to begin growth following a drouth in July or August is apparent. Rapid growing crops are usually preferable to slow growers, although at times for special purposes the slow growing crop may be more advantageous.

Cover Crops as Plant Food Suppliers—Cover crops may be made to serve the purpose of increasing plant food in the soil. Not all crops used

for covers are able to do this. Only leguminous crops such as clover, peas and vetch are capable of adding plant food, and these only nitrogen. The leguminous cover crops, however, are a valuable asset in keeping up the fertility of the orchard. If used too continuously they prove detrimental for excessive nitrogen tends to cause excessive wood growth at the expense of fruit production. It also favors late growth, and in this way may result in considerable winter top-killing. Because of these unfavorable conditions which are likely to arise, it is a good plan to practise rotation of cover crops, using leguminous crops on average soils not more than two out of three successive years.

Hardy and Non-Hardy Cover Crops—In addition to being divided into food supplying and non-food supplying, cover crops are also classified as hardy and non-hardy or tender crops. The hardy crops live over winter and make some growth in the spring, thus increasing the vegetable matter returned to the soil. They may or may not be efficient in holding the snow or preventing deep freezing. Hairy vetch, although a hardy crop, is usually less efficient in these respects than is oats, which is non-hardy, but which stands up well after frost.

In the food-supplying, hardy group of cover crops are hairy vetch and crimson clover, the latter of which can only be considered half hardy in the Northwest. Of the tender food-suppliers, we have field peas and soy beans. Of the hardy non-food-supplying class, the most important is rye, but wheat is occasionally used. The increased cost of the seed, and the fact that the character of its growth is much the same as rye, makes the former more in favor.

Of the non-food-supplying tender crops, oats, millet, turnips and rutabagas are the most used. The two latter might be placed in a class by themselves due to the fact that they have tender tops which kill back with the frost, but roots which live over winter and produce growth the following season. It is not necessary that each crop be grown alone; frequently two or more are grown in combinations. Probably the most used combination is that of oats and Canada field peas.

Some of the chief advantages and disadvantages of the various plants mentioned above, in their use as cover crops, are:

Hairy vetch is especially hardy; makes rapid growth in spring; is slow to catch in a dry season; makes slow growth in fall; is low and does not hold snow as well as some of the other crops.

Crimson clover can only be recommended in certain localities owing to the fact that it winter kills. Where it is hardy it makes a very good cover if a catch can be secured.

Field peas are one of the best food-supplying crops; make a heavy growth; are especially valuable when mixed with some other crop which provides support.

Soy beans are more tender than field peas, but stand up better after frost.

Rye is the best non-food-supplying hardy cover; does not make as much growth as oats in the fall, but stands up somewhat better during the winter.

Oats is probably the most used of all covers; comes quickly when sown, makes a good growth, stands up fairly well during the winter.

Barley possesses about the same merit. Some growers like it better.

Millet is similar to oats, but less hardy and does not stand up as well. Turnips and rutabagas add considerable vegetable matter, but lack the essential qualities necessary for holding snow; they are especially valuable for rendering available phosphoric acid.

Amount of Seed for Cover Crops—The amount of seed to be sown for the various crops is practically the same as that in ordinary field culture. It is better to err on the side of having the cover too thick rather than too thin. There is little danger on the side of the former, save in the expense of seed, as the denser the growth the better it stands up, and therefore the better it holds snow.

The following amounts may be considered as indicating the quantity of seed to be used per acre:

Hairy vetch, 1 bushel; crimson clover, 15 pounds; field peas, 2 bushels; soy beans, 3 to 4 pecks; rye, 1 to 1½ bushels; oats, 2 to 3 bushels; barley, 1½ to 2 bushels; millet, 6 pecks; turnips and rutabagas, 4 pounds.

It is well to harrow the ground just before sowing, and to put in the crop exactly the same as for field conditions. Once in the ground, the crop needs no further attention until time for cultivation the next spring, when it is to be plowed under and the system of clean culture again taken up.

Occasionally an orchardist stops cultivating at the proper time, and allows nature to provide him with a cover crop in the form of weeds. It would hardly seem necessary to advance any argument against such a procedure. The growing of weeds as a cover crop simply means that the labor expended in eradicating them will in time more than offset the cost of using a legitimate cover. Some may say that the season of growth will be too short for the weeds to ripen seed. If this be true, it will only be a short time until those weeds which produce the cover are those which have a short season and ripen seeds early, for unless this be so, the weed cover crop must in a short time lose its source of seeding and become a thing of the past. At the very best, a cover crop of weeds is an uncertain thing.

SOIL CARE IN THE YOUNG ORCHARD

As previously stated, the young orchard presents different conditions influencing soil management. Bringing the orchard from planting

to fruiting as economically as possible will, in the majority of instances, practically preclude the clean-culture-cover crop system up to the time the orchard begins to give returns from the fruit produced. The question then resolves itself into: "What is the best practice in the cropping of a young commercial orchard?"

The length of time during which a young orchard may be cropped successfully, which means without injury to the trees, cannot be definitely stated, as it depends primarily upon the age at which the trees come into bearing. It is a mistake to grow other than fruit crops in the orchard after it has reached the bearing period. The length of time for which the orchard will be cropped will then be much less in cases where early bearing sorts as Transparent and Duchess are used, than where the orchard is composed primarily of later bearing sorts like Northwestern Greening.

No small grain crops are permissible if they are to be used for other than cover crops. The choice of crops to grow in the orchard will therefore rest between the cultivated field crops, small fruits and vegetables. The last as a rule may be passed over without much consideration. Practically all the small fruits can be grown successfully between the rows of trees in the orchard. With the field crops, potatoes, beans, and possibly corn, and tomatoes when grown as a field crop rather than a garden crop, will comprise very largely the list which is permissible. The least desirable of these in the orchard is corn, the height which it attains, in many instances gives too much shade, particularly if planted close to the rows, and also restricts the free circulation of air through the orchard. Good air circulation is very important as a means of keeping in check various diseases which attack the trees.

The rotation of crops in cropping the orchard is not of extreme importance, especially if the practice of returning the plant food by the use of fertilizers is followed. The orchard should be cropped only for a few years at most, and the evil effects experienced in the ordinary length of time would be small. However, both from the standpoint of effect upon the orchard soil, and the return from the crop, rotation is doubtless advisable.

A rotation where potatoes and beans are used is as satisfactory as any. The usual length of time for cropping an orchard of the early bearing sorts should not exceed four or five years where two to three-year-old stock is set. For a three-year rotation, potatoes, beans, early potatoes would be a good combination. Follow the first crop of potatoes with a liberal application of barnyard manure. The crop of beans may be followed by commercial fertilizers in which potash and phosphoric acid largely predominate. The early potatoes should be dug as early as possible, and then a cover crop of rye or other hardy cover should be sown. The object of the cover is to protect the soil and fur-

nish vegetable matter to be incorporated into the soil the following spring. In a four-year rotation, beans would replace potatoes as the first crop grown. In a longer period of cropping, corn might be used advantageously providing it was kept a considerable distance from the trees.

The question of the portion of land which may be used in orchard cropping is one which is open to various opinions. It will depend first upon the distance between the trees, and second, upon the age of the orchard. In a newly planted orchard a strip three to four feet wide should be devoted entirely to the growth of the trees. As the size of the trees increases from year to year, this space should be gradually increased. At all times it would be advisable to give the trees all of the soil which the roots permeate, and use only that unoccupied by the trees for the crop which is to be removed. The mistake is too often made of growing other crops too close to the trees, often resulting in permanent injury to the trees.

FERTILIZATION OF THE ORCHARD

There is no other factor of orchard management that is so little understood, and about which less definite information can be given than orchard fertilization. This is largely due to the fact that carefully performed experiments to determine what are the best methods of orchard fertilization have given contradictory results. One thing is certain, that orchard soils differ so much in their composition, and treatment, that no hard and fast rules can be made. It is largely a matter of each grower determining for himself what is the limiting factor in the production and then bringing that factor up to the normal. The limiting factor may not be a deficiency in any element of plant food, but one of cultivation or lack of vegetable matter in the soil.

It is generally conceded that on ordinary soils a newly set orchard will not need fertilization until the bearing age is reached, unless other crops are being grown. In this event if the fertility of the orchard soil is to be maintained there must be returned to the soil the equivalent of the plant foods removed.

When the orchard begins to bear heavily, the question arises as to how long it may be allowed to go without the addition of plant food. Here again the character of the soil and its treatment previous to orchard planting will be the determining factors. Lighter soils will usually need fertilizers sooner than the heavier ones. This not only applies to the initial application, but throughout the subsequent growth of the orchard it will be found that the lighter soils will require heavier and more frequent applications. The food supply of orchards on heavy soils is more dependent upon keeping the soil in good tilth so that the plant food which is usually quite abundant may be rendered available.

It has long been held that the application of large amounts of potash, phosphoric acid and lime to orchard soils were beneficial in hastening the maturity and heightening the color of the fruit. Practically all authorities on orchard fertilization have held to that belief until recently. In an experiment carried on at the New York Experiment Station contradictory results were obtained. This experiment covered a period of twelve years, during which time little beneficial results were noticed on the color of the fruit by applying potash, lime and phosphoric acid, in the form of wood ashes and acid phosphate.

Offsetting the results just quoted are those of the Massachusetts and Pennsylvania stations, in which beneficial results were obtained by the application of these plant foods. It is quite evident that other factors will very largely influence the results secured by the application of fertilizers to the orchard.

With the average grower the application of a nitrogenous fertilizer, the incorporation of vegetable matter into the soil, and keeping up a good tilth are undoubtedly the operations of most concern. Lack of nitrogen is a limiting factor in fruit production more often than is usually thought. Its deficiency is indicated by short annual growths, and an unhealthy or yellowish green appearance of the leaves. In applying nitrogen, however, care must be exercised not to give excessive amounts, for, as noted in the discussion of cover crops, this will have a tendency to produce excessive wood growth and loss of color in the fruit. It should be recognized that any general formula for orchard fertilization can only be suggestive, as differing soil conditions and different plants would require its modification to meet the special case in hand.

Where plant food is deficient, a very good system of orchard fertilization is the application of from eight to ten tons of barnyard manure per acre once in two years. This should be supplemented, in the alternate years, with 150 to 200 pounds of 15 per cent nitrate of soda, or 250 pounds of 13 per cent dried blood; 350 pounds of ground bone containing 20 per cent of phosphoric acid, or 250 to 300 pounds of 14 per cent acid phosphate, and 150 to 200 pounds of 48 per cent sulphate of potash. These materials should be broadcasted between the rows. It is a mistake to apply fertilizers at the base of bearing trees, as the feeding roots are well out between the rows.

The nitrate of soda is readily available and probably best applied either in mid-season or in two applications, one in the spring and the other in August. The ground bone is not all available in the two-year period and therefore after the first application may be reduced somewhat.

Where leguminous cover crops are used, the amount of nitrogen fertilizer and manure may be materially reduced, and in some cases may even be discontinued. It must be remembered that one of the chief advantages of using manure is that it supplies considerable vege-

table matter to the soil. This is even more important than the plant food which it furnishes. No matter how much plant food is present in the soil, the trees will be unable to profit by it unless there is organic matter in the soil as well. The first thing, then, in the orchard which seems to be suffering from lack of food is to see that the soil is well supplied in this respect.

But slightly less important to food supply than organic matter is a good cultivation. - The lack of cultivation in its bearing upon the availability of plant food is one of the serious objections to the sod-



FIG. 3. NEGLECTED TREE

Trees like this should be pruned to open the head and to remove superfluous branches.

Courtesy of the Wisconsin Experiment Station.



FIG. 4. WELL PRUNED TREE

Facilitates spraying and harvesting and produces larger crops of better fruit.

Courtesy of the Wisconsin Experiment Station.

mulch system of orchard management. Unless the soil is cultivated the best conditions are not given for rendering available the plant food already in the soil. Good tillage should therefore precede the application of fertilizers to the soil.

If the orchard shows indications of lack of plant food, supply vegetable matter by means of the cover crop or barnyard manure, and incorporate it into the soil by thorough tillage; then if the orchard does not respond properly it is soon enough to begin artificial fertilization.

PRUNING THE BEARING ORCHARD

Pruning is one of the most neglected practices of good orchard management. Neglect of the trees in this respect does not usually show its

injurious effects as readily as lack of spraying or fertilization, and for that reason is frequently considered of minor importance. No one at the present time argues that rational pruning is detrimental to the tree, but it is a fact that in a very large majority of orchards no rational system of pruning is followed. The little that is done is usually haphazard and spasmodic, and not infrequently more injurious than beneficial.

Neglected pruning, especially of young trees, can never be corrected so as to give as good a tree as though the work had been done at the right time. The writer cannot agree with some who advocate letting the tree grow at will until the bearing age is reached and then trying to correct the errors of four or five years' standing. As stated in the discussion of pruning the newly planted tree (Chapter III), the first pruning is the most important factor in the history of the plant, unless it be pruned to a whip, but those immediately following it are of only slightly less importance. If the tree be properly pruned during these years, the matter of pruning after it comes into bearing is a great deal less troublesome problem than if the work has been only half executed.

Pruning during the early stages of a tree's development has for its primary object the formation of an ideal fruit bearing area. Making up this ideal are such factors as proper branching, keeping the head open, encouraging the production of fruit spurs, correcting defects of growth, and keeping the head down so that spraying and harvesting will be facilitated. To secure this ideal or even approach it, pruning must be done at least once each year, and when done not be a matter of merely going through the orchard and clipping out a branch here or there. Each tree must be carefully studied as to its individual characteristics and then pruned accordingly.

The Time to Prune—It has been said that the best time to prune is every month in the year. If carried out consistently, this is undoubtedly true, but most growers would find it inconvenient to do so. Pruning is not confined to any distinct periods or seasons. Some of the best growers carry heavy pocket knives and whenever they see a small branch which is undesirable they remove it. As a rule, however, pruning as a distinct practice is performed during the late summer, and known as summer pruning, or during the dormant period and called winter pruning.

Summer pruning tends to induce fruitfulness in trees which are prone to throw all their energy into vegetable growth, but it is a devitalizing process. Followed for any considerable period it causes a decline in both vigor and fruitfulness of the tree. It cannot be recommended as a general practice. Winter pruning may be done at any time during the dormant period. Late winter or early spring is generally preferable to early winter. Where branches are removed early in the dormant period, the wounds make no progress toward healing until growth starts

in the spring. These wounds permit a much more rapid evaporation of moisture from the tree and unless carefully protected are very likely to check and become favorable places for fungus and bacterial diseases to gain a foothold. The delicate cambium layer which forms the new tissue for healing the wound is also likely to be killed back for some distance from the edge of the wound, making it a very much more difficult matter to secure proper healing. If done in late winter or early spring, just before growth starts, the probability of injurious results is materially reduced.

Second Season's Pruning—Pruning the young tree the second season after setting consists primarily in removing the superfluous branches



Fig. 5. Cutting back second year growth produces crooked branches, as the latter growth will not be erect.

Courtesy of the Wisconsin Experiment Station.

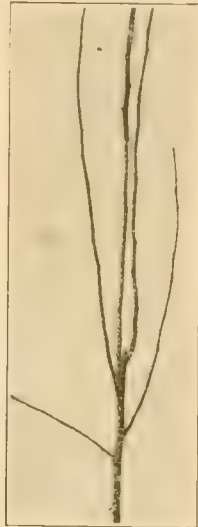

Fig. 6. To cut back one year old growth does not materially change the direction of the limb and keeps fruit-bearing area low.

Courtesy of the Wisconsin Experiment Station.

which have been formed on the main branches chosen at the first pruning, and in shortening the growth. The tendency to leave too many branches the second year is almost as great as at the first pruning. Two or three strong branches, depending upon the number of main branches left, will be sufficient to fill in the head. They should be well distributed on the main branches, and quite near the base of the branch so as to keep the top of the tree low and the foundation strong. Branches with a tendency to grow into the center had best be removed the second season as there will be sufficient time to thicken up the head later on. Those chosen for further development of the head should be shortened or headed-in. The amount to be removed will depend upon the extent

of growth during the past season, and the character of the tree. Occasionally, heading-in will not be necessary, but as a rule from one to two-thirds of the past season's growth should be removed. Trees with a weak, slender growing habit will be cut back more than those making strong heavy branches.

At this pruning, precaution should be taken to correct any defects in the direction which the branches are taking. If there are open spaces being left in the top, prune so the top buds of branches on either side will be on the side next to the opening. If the branches have a tendency to grow too upright, cut back so that the top bud will be on the lower or outer side; if they spread too much, have the bud on the upper or inner side. Pruning back to a particular bud is of great importance in the early pruning of a tree if the best head is to be secured. Many growers pay too little attention to this matter when heading-in.



Fig. 7. Cut one year growth back to a particular bud. By this method open space may be filled. Cut so as to protect the bud, allowing the branch to project slightly beyond the top.

Courtesy of the Wisconsin Experiment Station.

Choose, if possible, a good strong bud in the position in which desired. In cutting back, make the cut just above this bud. A strong knife will be found best for this purpose. Cut across the branch diagonally beginning at about the level of the bud on the opposite side of the branch, and come out on the other side about an eighth of an inch above the top of the bud.

This leaves the bud protected and gives a wound which will heal rapidly.

Third Year Pruning — If the pruning during the first two years has been properly done, that for the third year will require less attention. The frame work of the tree should be formed by this time so that the pruning will consist almost entirely in removing superfluous shoots and cutting back the new growth which is to be left. Branches which rub or are inclined to form bad crotches should be removed. Too many branches should not be allowed to grow into the center of the tree as it is desirable to keep the head quite open to permit the entrance of sunlight and allow good air circulation through the top. Pruning for subsequent years will follow closely that outlined for the third season.

PRUNING NEGLECTED TREES

One may find himself in possession of an orchard in which the pruning has been neglected. Putting such trees into good condition is quite a difficult problem. The first thing that the grower should realize is that usually this operation will require more than one year. As a rule the top of a neglected tree resembles a brush heap. It is very dense and a large proportion of this growth should be removed. However, if this is done in a single season, the tree is forced into a heavy top growth, and

conditions are almost as bad at the end of the season as they were at the beginning.

In pruning a neglected tree the first thing is to cut out the dead wood. This should be followed by removing the water sprouts or suckers that have arisen from the main branches. If these are not numerous, the more seriously interfering branches will next receive attention. Usually this is about all that it is advisable to do the first season unless it is the intention to replace the old top, when, of course, the pruning will be much more severe.

Pruning the second season consists in removing the new growth of water sprouts and further opening up the top if desirable. Unless the top is to be renewed, it is advisable to remove no more large branches than is necessary as this is likely to leave large openings in the tree. If the tree has begun to make much growth at the ends of the branches, these twigs may be headed-in as in the regular pruning. Frequently the entire top is renewed. When this is done, the greater portion of the top is removed and the new head developed from growth arising from the stubs which have been left.

Spasmodic Pruning Undesirable—Pruning should be an annual operation. Many growers prune at intervals of three or four years, but this is a very undesirable method. In the first place, it will take less time to prune properly when done, at least once every season than to let the growth accumulate for three or more years, and the results will be much more satisfactory. A small branch or twig is much more quickly removed than when it has grown for a considerable time; it has not made so large demands upon the tree for its food supply and has caused no evil effects by crowding other branches which it is desirable to leave for permanent use.

When done at long intervals, pruning has a tendency to disturb the equilibrium of the tree, and to retard or diminish fruit production. It is evident that if no pruning is done on a tree for a period of years, that the amount of wood to be removed at one time will be much greater than if annual pruning is practised. Heavy top pruning tends to wood production. As a tree cannot turn its activities strongly in two directions at the same time, it follows that fruit production will be reduced until the tree has regained its equilib-



FIG. 8.—POOR PRUNING

Such stubs become the source of infection, often resulting in injury and premature death.

Courtesy of the Wisconsin Experiment Station

rium. This balance is quite difficult to obtain for the vigorous vegetative growth induced by the heavy pruning runs quite largely to the production of water sprouts or suckers which are worthless, as a rule, and should be removed. These difficulties can be almost entirely overcome by practising annual pruning.

WOUNDS, THEIR MAKING AND TREATMENT

Neglect or improper making of wounds frequently results in serious injury or even premature destruction of the tree. Neglect in pruning is usually accompanied by carelessness in making and neglect in caring



FIG. 9. CUT IMPROPERLY MADE
Do not cut branches through the shortest diameter.

Courtesy of the Wisconsin Experiment Station



FIG. 10. CUT PROPERLY MADE
Cut branches off as close as possible to limb.

Courtesy of the Wisconsin Experiment Station.

for the wounds. Just the reverse should be true for the wounds will be larger, and if they are to heal, the utmost care should be taken in these respects.

In pruning young trees or where thorough annual pruning is practised a strong knife and small hand shears are all the tools that are necessary until the tree reaches the height where a pole pruner will be needed for heading-in the top branches. On newly set trees, a strong knife is more desirable than the hand shears because the branches can be cut off nearer the trunk. By cutting from below upward toward the trunk or branch to which it is attached, quite large branches may be removed without

difficulty. Care should be taken as the branch is nearly severed that the knife does not come through suddenly and injure other branches which are to be left. In removing branches with the pruning shears, put the blade next to the trunk or main branch and press the branch to be removed away from the blade.

Removal of large branches is a more difficult proposition as there is danger of the branch breaking down and splitting into a ragged wound, or pulling off large areas of bark. To avoid this, double sawing is usually desirable. It consists in cutting the branch off some little distance from the trunk or main branch, and then removing the stub. In the first sawing, it is well to saw one-third to one-half through the branch from the under side, then finish the sawing from above. The upper cut should be made slightly farther from the trunk than the under. This method overcomes splitting back. For removing large branches, a pruning saw is desirable, of which there are a great many forms on the market. The ax should never be used.

All branches should be cut off as near the branch or trunk to which they are attached as possible, and the cut should be made parallel to the part from which removed. While this makes a somewhat larger wound, it will heal more readily than a small wound made in any other way. Stubs are monuments to the ignorance of the pruner, unless one-year-old growth left for the production of fruit spurs. On older wood they are valueless, seldom heal over, and become sources of infection and decay.

Care should be taken to have the surface of the wound smooth. Rough or splintered wounds heal slowly and the longer the time required in healing, the greater the danger from infection. If the bark has been torn around the edges of the wound, the uneven edges should be cut back to sound bark. Sharp tools are necessary for good work. The knife, pruning shears, and saw usually make good wounds with ordinary care, but dull tools should always be avoided.

Wounds a half inch or more in diameter should be treated—those which are smaller heal so readily that it is unnecessary. Any material that is adhesive, will prevent checking, keep out moisture and fungi, and will not injure the cambium, may be



FIG. 11.
WOUND PROPERLY HEALING.
Blossoms.

A properly made wound heals readily. When very large they should be protected by a coat of lead paint.
Courtesy of the Wisconsin Experiment Station

used. The object of treating the wound is protection, thus insuring good healing. The material used will not hasten the healing only as it prevents unfavorable conditions. One of the best, cheapest, and most easily applied materials is white lead. It should be quite thick so as to give a heavy coat when applied. Other materials frequently used are grafting wax and pine tar. The former is expensive, and does not adhere so well as lead; the latter is rather disagreeable as well as expensive.

SPRAYING

Spraying is an essential part of good orchard management. In fact, without spraying it is practically impossible to produce fruit which is fit for the market or even for home use. Spraying practice will differ considerably in various parts of the United States, as the pests attacking fruit plants will vary somewhat; and owing to the difference in climatic conditions, even the treatment for the same pests may need to be modified. It is not the aim in discussing the spraying of the orchard to go into the differences in the spraying programs of various sections in detail, as the control methods and the life history of any particular insect may be found in Book IX, Insect Pests and Diseases.

Spraying Program for the Apple Orchard — In the northern states the following spraying program will be found satisfactory for the control of the more common apple pests.

(1) Before buds open, spray with lime sulphur, 1 gallon to 7 or 8 gallons water. This is used primarily for the control of scale insects and plant lice. If scale insects are not serious, nicotine sulphate may be substituted for the control of the aphid. It is not always necessary to make this application.

(2) When flower buds show pink, use a spray of lime sulphur, $1\frac{1}{4}$ gallons and arsenate of lead (powder) 1 pound; or arsenate of lead paste 2 pounds to 50 gallons water. This is used against apple scab and curculio. It may also be effective against other leaf-eating insects.

(3) Within ten days after the petals have fallen, and before the calyx lobes close, repeat spray under (2). This is the most important spray in the control of codling moth or apple worm. It is also important in the control of apple scab and curculio. Be sure to get the material into the calyx cup.

(4) Three to four weeks after petals fall, repeat spray under (2).

(5) From about July 20 to 30, repeat spray under (2). This is primarily for the control of the second brood of the codling moth. The time of application will vary with different sections. The time given is for northern parts of the United States. Applications should be made earlier or later, depending on whether the section is north or south of that mentioned. Bordeaux mixture may be substituted for lime sulphur with comparative safety for all applications except (3).

Where bitter rot and sooty fungus are troublesome other applications later than that for the second brood of codling moth will need to be made.

Fire blight of the apple and pear cannot be controlled by spraying. Cut out infected twigs several inches below any evidence of the disease. If producing cankers on large branches or the trunk, cut out infected area and treat wound with strong formaline.

Spraying the Pear— Pear pests are much the same as those for the apple and the spraying program for the common pests is practically identical with that of the apple.

Spraying the Plum— The most important pests of the plum which can be controlled by spraying are curculio, brown rot, and shot-hole fungus. Although some of these are not perfectly controlled, spraying assists materially in keeping them in check.

Use the same materials as recommended for apples in applications (2), (3), (4), and make applications about the same time.

Spraying the Cherry— Follow the same directions as for spraying the plum. Make additional applications, using the same materials soon after the fruit has been harvested.

Spraying the Peach— For early varieties use arsenate of lead and self-boiled lime sulphur two to three weeks after petals fall. One month before fruit ripens, spray with self-boiled sulphur.

For mid-season varieties, spray with arsenate of lead ten days after petals fall for curculio. One month after petals fall use self-boiled lime sulphur and arsenate of lead. One month before fruit ripens, use self-boiled lime sulphur.

For late varieties the spray is the same as for mid-season varieties with an additional application of self-boiled lime sulphur about three weeks after the second spray.



Courtesy of the Minnesota Experiment Station

CHAPTER V

STRAWBERRIES AND BUSH FRUITS

- I. **Strawberries**—PLANTS—LOCATION—SOIL—PREPARATION OF LAND—TIME TO PLANT—PLANTING—WINTER PROTECTION—RENEWING BED—PICKING AND MARKETING—STAMINATE AND PISTILLATE FLOWERS—VARIETIES. II. **BUSH FRUITS**—**Raspberries**—TYPES—SOIL AND LOCATION—PREPARATION AND FERTILIZATION OF SOIL—TIME TO PLANT—GETTING PLANTS—PLANTING—CULTIVATION—PRUNING AND THINNING—TYING, STAKING, TRELLISING—WINTER PROTECTION—HARVESTING AND MARKETING—VARIETIES—PESTS—**Blackberries** and **Dewberries**—TREATMENT—VARIETIES—**Currants**—PLANTS—PLANTING—CULTIVATION—PRUNING AND THINNING—HARVESTING AND MARKETING—VARIETIES—**Gooseberries**—TREATMENT—VARIETIES—PESTS.

STRAWBERRIES

The strawberry is probably the most widely-grown fruit in the world. There are varieties adapted to almost every climate and condition, from Alaska to Florida. Our cultivated kinds have been developed from the Chilian strawberry (*Fragaria chilensis*) and the common wild strawberry (*Fragaria virginiana*). The Alpine strawberry (*Fragaria vesca*) of Europe is probably the parent of the ever-bearing varieties which are coming into prominence just now in some places. The strawberry is one of the first fruits on the market in the spring, and hence is always welcome.

Propagation—The strawberry is propagated by seed, by division and by runners. In common with other fruits, the seeds do not come "true"

—that is, do not reproduce plants like the parent plant; hence, division of the old crowns or the use of runners afford the only practical methods of propagation.

New varieties are produced by seeds. The berries are crushed in sand as soon as ripe, to get rid of the pulp and juice, and the seed is then sown at once in a sandy loam, in a box or open bed. The plants grow very quickly. As soon as large enough, they are transplanted to a bed, four inches apart, and left over winter. They should be mulched with about six inches of hay or straw, as soon as the ground freezes. In the spring they may be set in the fruiting bed. About one plant in a thousand may prove of exceptional value. However, many people find pleasure in developing new varieties.

Division of the old plants is never used except in case of a very choice variety, that cannot readily be propagated by runners. It is too uncertain and slow a method. Propagation by offsets or runners is the best method. These runners develop during the summer, and the next spring may be separated from the old plant and set out in the permanent bed. Usually these root readily; if they do not, a little earth may be thrown over the tip early in the summer, to aid in rooting.

Location—A northern slope is to be preferred, as the plants do not start so early in the spring. They thus escape the early frosts and they are not so likely to be dried out by the hot south and southwest winds at fruiting time. Many growers, however, obtain good results on a southern slope, in spite of the disadvantages.

Soil—Any land that will grow a good crop of corn will grow strawberries. Sod land should never be used if it can be avoided, as it is likely to contain grubs and cut-worms, which may eat off the roots of newly-set plants. A well-drained, friable clay loam is probably best for strawberries—a soil that warms up easily and yet will hold sufficient moisture for the crop.

Preparation of Land—Strawberries require a rich soil, hence it is well to thoroughly manure the land that is to be used for the crop in the fall, and plow from four to six inches deep. In the spring, disk, drag and smooth thoroughly. This gives a loose soil in which to set the plants, and a firm subsoil to hold the moisture, and yet open enough to let the roots through.

Time to Plant—The best time to set a strawberry-bed is the early spring, as soon as the land is in good condition and the plants can be obtained. There is more moisture as a rule at that time; and this, combined with the cool weather of spring gives better growing conditions than August planting. Plants may also be set in the fall if extra attention and care are given them. It does not pay to set the plants in dry soil or in a dry season unless plenty of water for irrigation purposes is available.

Heeling-in Plants—It often happens that strawberry plants are received in a dry or weakened condition, or that the soil is not ready for their planting. They may be "heeled-in," or temporarily planted in some sheltered place until they have recovered or the land is ready to use. Open the bundles in which the plants are received, dip the roots into muddy water and set in rows close together, placing a little dirt between the plant so that they will not heat. Pack the soil firmly over the roots so they will not dry out. If the plants have been weakened in transit, they should be shaded for a few days until they recover. It is also well to protect them from the wind.

Plants—Plants having a small crown, and a large number of white fibrous roots, are best for planting. It is not a good plan to use plants

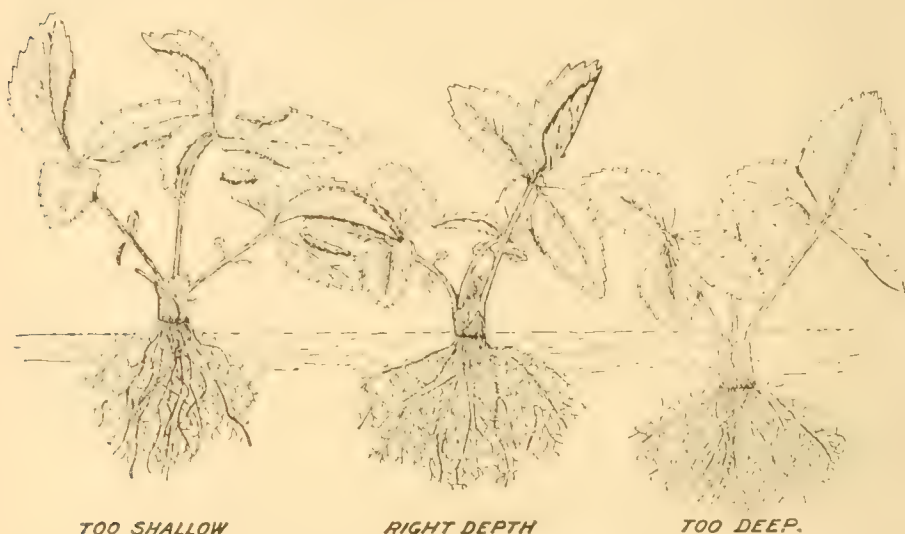

Fig. 2. Setting Strawberry Plants. The setting of the plant on the left is too shallow; that at the right is too deep; the center plant is properly set, with its crown even with the surface of the ground.

Courtesy of the Minnesota Experiment Station

that have borne fruit, as they are weaker. The best plants are obtained from plantations that have not been allowed to fruit. Their roots are white, while the roots of the old plants are brown. Before planting, all but two or three leaves should be removed. The roots may be pruned back to about three or four inches. All flowers should be kept off the plants the first season, as this results in stronger growth. When plants are bought, it is best to get the plants from a nurseryman or strawberry specialist, as they are not so likely to be mixed as when obtained from a neighbor.

Planting—There are several methods of planting in general use, which may be modified to suit the planter. The method in most common use is the matted row system. In the spring, when the land is in

good condition to work, harrow smooth and mark out rows four feet apart and as long as possible. Then set the plants at 18 or 24-inch intervals in the rows.

An ordinary planting trowel or spade is used to set the plants. The soil is easily opened with a spade. Strike it into the ground and work it back and forth, draw out the spade, spread the roots of the plant, and set it so the crown comes just to the surface of the ground, as shown in Fig. 2. Firm the soil well about the roots of the plant. This method requires a man to handle the spade and a boy to set the plants. As soon as possible after setting the plants, cultivation should commence, and it should continue at frequent intervals till fall. Keep the weeds down and the top soil loose. If the runners get too thick, cut out some of them, leaving them about six inches apart. Runners may be encouraged to root by putting an inch or two of soil over each one.

Winter Protection—In northern sections it is necessary to protect strawberries from freezing and thawing during the winter. Usually a mulch of clean hay, marsh grass or straw about three inches deep is spread evenly over the bed late in the autumn, or after the ground has frozen in early winter. Some growers prefer to put on a light covering of straw before any severe freezing occurs, adding more late in the fall. In exposed locations, such as the Dakotas and western Minnesota, it is often advisable to apply from four to six or eight inches of mulch. A good fall of snow acts as a protection, but is too uncertain as a rule to depend on. In the spring most of this mulch should be taken off the plants. A large part of it is left between the rows, but a thin layer should be left over the row so that the plants may grow up through it. This helps keep the fruit clean and aids in conserving moisture. The mulch may also be thrown back over the plants if there should be danger of frost when they come into flower. On land that is likely to bake, it is sometimes a good plan to take off all the straw and cultivate the land thoroughly, then put the straw back shortly before the fruit begins to ripen.

Renewing a Strawberry Bed—Some growers prefer to fruit the bed only one season; in this case as soon as it is through fruiting, the bed is plowed up and some late crop, such as turnips or fodder corn, planted on the land. If it is desired to keep the bed fruiting more than one year, the following plan is often used: As soon as the bed is through fruiting the plants are mowed close to the ground with a horse-mower or by hand, the bed is raked clean and the trash burned; or the bed may be burned over without raking. If this is attempted, however, the leaves and straw must be very dry, so they will burn like a flash, otherwise injury will be done to the plants. When the trash is disposed of, plow a furrow on each side of the row, leaving about one foot of row standing. Fill this trench with well-rotted manure, and cultivate lengthwise

of the furrows and then crosswise. Then with a sharp hoe cut out all weak and diseased plants, leaving the plants about six inches apart. These will soon send out runners and form a new bed by fall. In this way much diseased foliage and some insects are destroyed. A horse cultivator can often be used instead of a plow for narrowing the row.

Picking and Marketing—The use to which the fruit is to be put will influence the picking. If for home or local use the fruit may be picked somewhat riper than if it is shipped a long distance. Frequency of picking will depend largely upon weather conditions. Fruit should be picked at least every other day under ordinary conditions, and when the fruit is ripening rapidly, every day. Allow no over-ripe, small or green fruit to go into the package. Do not pick when the fruit or vines are wet, as this will cause the fruit to be soft and to spoil in transit. The fruit should be put in a shady place as soon after it is picked as practical. It is unsatisfactory to depend upon pickers to grade and pack the fruit, especially if a superior pack is desired. As a result many growers take the fruit from the field to a packing shed, and there repack, using only ripe, uniform-sized fruit in the package. Neatness of package, as well as quality of fruit, is a great factor in marketing. Strawberries are usually marketed in crates holding 16, 24, or 32 quart boxes. Use new crates as they are neater in appearance. Some growers use paper boxes with fairly good results; but they are not usually considered as good as wooden ones.

Staminate and Pistillate Flowers—There are two classes of strawberries, known as staminate and pistillate, or perfect and imperfect varieties. The staminate or perfect varieties have well developed stamens and pistils, the male and female organs of the flower. These varieties, as a rule, will bear fruit when planted by themselves. The pistillate varieties have only the pistils or female part of the flower. In order for these to bear fruit, it is necessary that perfect or staminate varieties



Fig. 3.—Perfect and Imperfect Strawberry Blossoms

be planted near them. Usually, where pistillate and staminate sorts are used, one row of staminate is planted to two or three rows of pistillate. Planted in this way, the pistillate varieties very often bear more fruit than the staminate. There is no way of distinguishing between these varieties when not in flower, although each has certain characteristics of plant-growth that may enable one very familiar with the strawberry to distinguish them.

Varieties—Among the best varieties of strawberries are the following: Perfect varieties: Bederwood, Enhance, Lovett, Splendid,

Glen Mary, Clyde, Senator Dunlap. Imperfect varieties: Crescent, Warfield, Haverland, Marie, Highland.

Of these, Senator Dunlap is considered one of the best by many growers. It has a tendency, however, to become too thick in the row, which it should not be allowed to do as this materially lessens the crop which it will produce. Bederwood and Warfield are two varieties very often used.

THE BUSH FRUITS

The term "bush fruits" includes a great variety of small fruits which are borne on low-growing, upright or trailing woody stems. In the blackberry, raspberry, dewberry and the hybrid brambles, these woody stems are biennial in character. In the cranberry, blackhaw and others, including the gooseberry and currant, they are persistent; yet with the last named the bearing quality of the wood is usually greatest at one to three years. In most of these fruits the bearing stalk is called a cane. In the Chinese raspberry and the strawberry raspberry, the canes are annual or herbaceous in character.

Raspberries—The raspberry, with the exception of the strawberry, is perhaps the most cosmopolitan small fruit. It is found native in nearly all parts of North America and in many other parts of the world. The varieties grown in this country are derived from the following sources:

(a) The European raspberry (*Rubus idaeus*). The varieties of this species were introduced from Europe, and for a long time comprised the only cultivated sorts. Except in a few instances they proved to be not well adapted to our conditions. The Red Antwerp is the most widely known variety coming from this source.

(b) The American (*Rubus strigosus*, the red raspberry, and *Rubus occidentalis*, the black-cap raspberry). From these two types and their hybrids come the larger number of our most widely-grown berries. The hardiest sorts are of this parentage. Among such varieties are Cuthbert, King, Turner, etc., of the reds; and Gregg, Older, Kansas, and others of the black-caps. There are also yellow varieties originated from these species, but they are not extensively grown.

(c) Hybrids of the above species give us both purple and red varieties. Examples are Columbian and Schaffer.

Two Types Are Grown—Notwithstanding the complexity of species and varieties above shown, only two types are existent, the upright growers and the drooping sorts or trailers. Nearly all the red varieties, especially the desirable ones, belong to the upright growers; while all the black-caps have the drooping characteristic. Purple canes may be either, but most varieties commonly grown have drooping canes. This

that the drooping sorts are less hardy than the upright growers. Without careful winter protection, in sections with rigorous climates, they will undoubtedly be less likely to succeed than the latter.

Soil and Location—The raspberries, like the strawberry, will succeed on any good corn soil. They like a great deal of moisture for their best development. Deep, loamy, well-drained soils are usually best. The soil for black-caps should be somewhat richer and heavier than for reds. A north slope is best, because it is not so likely to be affected by drouth in the latter part of the fruiting season, and because it retards growth in spring. The presence of abundant humus will go far toward correcting other soil defects. The choice of proper varieties will do much to eliminate dry-weather and climatic troubles.

Preparation and Fertilization of the Soil—The best fertilizer to use is stable manure comparatively free from straw or foul weed seeds. Apply a fairly heavy dressing to clover or timothy stubble in the fall, and plow under. If the soil is already quite rich in nitrogen, it may be desirable to grow a crop of roots or potatoes previous to setting the plants, or to dispense with manuring. The object in applying manure is to get a large amount of decaying vegetable matter into the soil—to provide as far as possible the natural, loose, leaf-mould composition of the forest where wild raspberries grow in such excellence.

Whether clover, or meadow, or cultivated area be used, it is desirable to plow in the fall and allow fall weathering. If plowing must be done in the spring, the top portion of the soil should first be thoroughly stirred with a disk or Acme harrow. This method will conserve the moisture in the soil to the best advantage.

On fall plowed ground drag as early in the spring as soil conditions permit. This will conserve moisture and assist in warming up the soil. Follow dragging with a disk or spading harrow, working the surface thoroughly. Some growers apply well-rotted stable manure just previous to this treatment.

Time to Plant—The upright or suckering varieties may be set with good results in the fall. In such cases, treat as for spring plowing, and follow as in the last paragraph. The plants may then be set, and mulched for the winter with a couple of forkfuls of a strawy manure. This is good, for this type, because the sprouts start so early in the spring that they are liable to be broken when being planted, especially if the operation is somewhat delayed. If these varieties are planted in the spring, it should be as early as possible. In the spring, when the weather has settled, the mulch may be removed or worked into the soil with the cultivator.

The black caps, or the tip-growing sorts, must be planted in the spring. Some claim that best results will be had by waiting until good, large sprouts have started from the tip plant. This sprout will help

the planter to set the plant at the proper depth more easily, as the sprouts are tender and easily broken. Others prefer to set the plants while the sprouts are small.

Getting the Plants—Raspberries are propagated by seeds, sucker plants, root cuttings and tip plants. Sucker plants and root cuttings are used with the upright growing varieties, tip-plants for propagating drooping varieties. The seed method of propagation is of value only to the plant breeder. The variations always present in seedlings make this method unsatisfactory for the home or market plantation.

Sucker plants are obtained by digging up the suckers or sprouts which stand in the outer part of the hills or rows. Care should be taken to get a good portion of the roots from which they arise.

Root cuttings give very good results. Dig up several large, thrifty plants in the fall; cut the roots in three-inch pieces, and stratify them over winter. In the spring sow these in shallow drills, in well prepared garden soil. A large per cent of them will throw up shoots and form well-rooted plants. This method will require a year to prepare the plants before they are set in the plantation. Extreme care should be used to get roots or plants from hills or rows that are thrifty and healthy. Leaf-curl, anthracnose and rust are often spread by carelessness in selecting plants from which to propagate.

Tip plants are secured by allowing growing canes to droop down, in the latter part of July or August, until the tip touches the ground. If the soil moisture has been husbanded by proper cultivation, they will usually strike root of their own accord. If the soil is loose and extremely dry, place earth over their tips with a spade or hoe. In late fall they will have rooted nicely. When laying down the canes for protection during the winter, where this is necessary, a foot or more of the cane should be cut free and allowed to stick up, to mark their position. They may then be covered along with the large canes, and be lifted for planting in the spring as previously stated. Where winter protection is not given they can be left attached to the parent until time for digging in the spring.

In many cases the prospective planter will not be able to provide himself with plants by any of the methods suggested. At such times, it is usually best to buy the plants from a near-by nursery if suitable stock can be secured. Buying from distant nurseries is likely to prove unsatisfactory, because of the difference in climatic conditions. Go to the nursery to get your plants if you can. If not, order early and signify the date for shipping. If they arrive a few days too early they should be heeled-in, in practically the same way as are strawberries.

Planting—Two methods of planting are in vogue, the hill and the continuous row. Many like the hill system best, for the following reasons: It gives better air drainage, and greater ease and thoroughness

in harvesting the fruit. It permits of better cultivation, which is essential to conserving the proper amount of moisture. It allows a better development of the fruit-bearing canes. Plant diseases are more easily controlled and larger, firmer fruits produced.

It has the following disadvantages when compared with the continuous row system: It requires more material and labor to keep the bearing canes supported. Fewer plants per acre can be grown. It is more difficult to lay down and protect the canes in winter. The trailing or drooping sorts cannot be so securely supported as by the continuous-row system.

If the hill system is to be used, the hills should stand 5 by 5 or 6 by 6 feet; which will give 1,210 hills per acre. One good, strong plant may be used in setting, but it is probably better to use two. In the continuous row system, the plants are set 3 by 6 to 8 feet, the distance depending upon the richness of the soil and the variety grown. Red raspberries are planted closer than blackcaps.

After the soil has been put in proper condition, stake out the rows. A single horse and a shovel plow, or a steady team and a stirring plow, may be used to open a furrow to receive the plants. A wire, on which knots of wool twine or muslin have been tied at proper distances, stretched over the row will insure the setting of the plants in a straight line and at equal distance apart.

The furrow will usually give depth enough for the sucker plants. If not, a hoe or shovel may be used. The plant should be set about three to five inches deep, slightly deeper than it stood in the soil originally. The roots may be covered lightly with the foot, and the operation completed with a hoe. The soil should be made firm around the plant by tramping. Do not water unless the soil is very dry. The plants should be carried in a pail a third full of water, and taken out only as fast as they are set. The wetting will help the soil to come in closer contact with the roots. Some growers set tip plants only slightly deeper than they were before dug. Others prefer deep planting, believing that the plants stand up better and are better supplied with moisture. If deep planting is followed, a furrow should be plowed, the plants set in the bottom of it and covered shallow. As the shoots develop, the soil may be filled around them or worked in by cultivation. On soils in which the sub-soil comes close to the surface and is of a heavy compact nature, shallow planting doubtless gives best results. In planting, the fibrous roots should be well spread and the soil firmed about them. Even greater care should be exercised to prevent the roots from becoming dry than with sucker plants.

Cultivation — Shallow cultivation should be begun as soon as the plants are set, and continued throughout the summer. Cultivation for subsequent seasons should be begun just as early as the soil is dry

enough in the spring, and the soil should never be allowed to bake or crust. This is very important, for in this way, in many years, moisture is retained in sufficient quantity to develop the fruit in the latter part of the fruiting season, when otherwise the crops would be a failure because of lack of moisture.

The best tool is the five-shovel or fourteen-tooth horse cultivator. Where the suckering sorts are grown, many growers prefer the sweep cultivator, because the blades, running just underneath the surface, cut the young suckers and keep the growth confined to hills or rows. It is a good tool in other respects if the soil is comparatively clean and not stony or excessively heavy.

The patch should not be seeded down, nor should grass be allowed to creep in. Grass requires too much of the moisture supply needed by the fruit and growing crops. If one wishes to ripen the canes in late summer, millet, oats or buckwheat may be sown thickly, to take up the moisture in the soil. If it is desired to enrich the ground for the coming year, soy beans or Canadian peas may be used.

Mulching is sometimes used as a substitute for cultivation, but it is doubtful whether the practice should be followed, as it affords too many chances for the introduction of weed seeds. It also causes the feeding roots to come to the surface, where they are more likely to be injured by cold. The suckering tendency cannot be so well controlled, and the mulch affords better harbors for insects and plant diseases. If used at all, it should be only in the rows and around the plants, leaving the spaces between the rows to be cultivated.

Pruning and Thinning—Not more than two shoots should be allowed to grow from each plant the first year. The second and succeeding years, each hill of the suckering kind will produce a great many shoots all around the hill. Only four or five of the strongest of these should be allowed to develop, the rest being treated as weeds. This is important; for if many or all are allowed to grow they will be weak, and their bearing qualities thereby decreased. If one does not have a sweep cultivator to use in keeping them confined, a sharp ordinary or scuffle hoe, or a sharp flat shovel, is a very good tool for working immediately around the hills and the rows.



Fig. 4.—Method of Covering Raspberries and Blackberries.

Courtesy of the Minnesota Experiment Station

The drooping sorts throw out their shoots from the root near the crown. The treatment for the first season is similar to that for the suckering kind. The second and succeeding years, five or six canes may be allowed to develop from each hill, the others being cut away or rubbed off while young.

The canes which have borne fruit should always be removed soon after the crop is harvested. This gives the growing canes a better chance. It also avoids much trouble from insects and plant diseases. The removed material should be carried off and burned. If one wishes to grow the berries without laying them down in winter, the tips of the young shoots may be pinched out when they are about 15 to 20 inches high. This will induce a sturdy tree form, that will stand with-



Fig. 5.—(a) Shows red raspberry canes topped too late in the season. (b) A single cane topped at right time to make it self-supporting.

out staking or trellising, and whose branches will have plenty of time to mature thoroughly before winter. If the topping is deferred until later in the summer, the head will have grown too high, so the cane will not stand alone in the wind when bearing; the check to growth is more complete, and the branches which are put out are more likely to be immature and freeze back to the main cane.

If one wishes to lay them down in winter — and this is always cheap insurance in regions with severe winters — the canes of the suckering sorts should not be topped at all. The black-caps (tip-growers) can never be made to grow so sturdy as the more stiff-caned sorts just mentioned. Tying, staking or trellising must be used for them. They should be topped at about $2\frac{1}{2}$ to 3 feet. Being less hardy than the suckering sorts, they must be laid down and protected through the winter. This will usually preserve their branches nicely. In spring, the suckering sorts, if grown in tree form, should have the branch canes cut back to about 15 inches. If grown in straight canes, cut back to 2 or $2\frac{1}{2}$ feet. In the black-caps, after they are uncovered and straightened up, cut the lateral canes to 12 or 15 inches. Leaving the full straight cane, or excessively long lateral canes, where branched, does not increase the crop; for the dry weather seems to catch those berries at the extremities, or there is insufficient plant-food to supply them, and they develop as “nubbins.”

Tying, Staking, Trellising —When the canes are grown in tree form, they are often allowed to stand alone. Sometimes, as additional support, a bit of wool twine, or an inch-wide strip of muslin is caught loosely about the canes comprising the hill and tied.

Where the canes, of either suckering or drooping sorts, are laid down in the winter, some system of staking or supporting must be devised. A single stake in the hill is the only method that can be used where the hill system is used. The bearing canes and growing shoots are loosely tied about the stake.

When the continuous-row system is used, heavy permanent posts or stakes, well-stayed, are set at each end of the plantation and a No. 12 wire is stretched at the proper height for tying canes to it. In the row it is supported by temporary stakes at intervals of 40 or 50 feet. When ready to lay down the plants in the fall, the wire is quickly removed and laid along one side of the plantation, the supporting stakes are pulled up, and the canes put down and covered.

In some places a No. 12 wire is put along each side of the row, supported by permanent posts and cross-bar fixtures at the ends of the rows. The canes are then allowed to hang out over the wires, which are held up between the posts as described in the previous paragraph. This saves the labor of tying, but requires more material, time and pains in erecting and tearing down—which usually has to be done in order to lay down the canes. If one can lay them down without removing the wires, this is a very good method. The distance between the wires should be about 18 inches, and the height should be such that the wire catches the canes just at the point of branching. Otherwise the rubbing by the wind may kill them or cause them to break off.

Winter Protection—Winter protection is a necessity in the Northwest, except in sheltered or favored locations. A few of the hardier sorts, such as King and Sunbeam, of the reds, and Older, of the black-caps, seem to withstand injury if a good fall of snow remains on the ground about them. But if they are in a bare place, the canes will probably be killed back almost to the ground. Protection at any rate is good insurance. Two men are required to do the work rightly. Facing to the north end of the row, one takes a spading-forkful of earth from the north side of the hill. The other man, with an ordinary pitchfork, pushes the canes to the ground. Planting the foot against the base of the canes, and pushing at the same time, is advised. This causes most of the bending to occur in the root, and prevents excessive breaking of the cane.

When bent, the canes are pinned down with the pitchfork while the other man throws on them a few forkfuls of soil, to hold them in place. In very severe climates, they should be covered later with soil, to a depth of three or four inches. This is not a slow or costly job. In instances noted, the cost by hand labor has been as low as \$1.75 per acre. Two men can do the work well and rapidly. It is not desirable to mix trash or weeds in the covering, as they afford a harboring-place for mice, which may injure the canes.

The covering should be removed with a round-tined fork in the spring, when the ground has become dry and settled. Some of the earth is scratched off, and the canes lifted to a slanting position with the fork. Many growers leave the canes slanting as far as possible, and believe it beneficial; otherwise they are carefully drawn up and tied or supported. The earth used for covering is worked back into its original position by the first cultivation.

Harvesting and Marketing — In growing for home use, the problem of picking and marketing is unimportant; yet, in order that the quality of the fruit be always the best, it is necessary that no berries be left on the bushes to become over-ripe. The following excerpt from Bulletin 87—Washington—gives directions for picking red raspberries for market. Practically the same directions apply to picking black-caps:

“Raspberries should be picked when they have turned red. They will color and ripen in twelve hours, and will have as fine flavor as if allowed to remain on the vines until entirely ripe. They should never be picked when wet or damp, nor picked nor packed for shipment during the extreme heat of the day. If picked when warm, berries should be allowed to stand in the picking-trays in the shade for a few hours before packing. The morning pick is the best long-distance shipper.

“A rigid inspection of bushes should be made by the field boss at each picking, to see that no ripe berries have been overlooked, to be picked over-ripe at the next picking; as a few of these will quickly spoil an entire case and may lower the grade of the entire shipment. The receiving packer should examine each tray delivered, to see that the berries at the bottom of the cups are as well picked as those at the top. Display on the receiving counter a cup of well-picked and filled berries, and call the attention to it of all pickers who fall below the standard.”

Probably the best receptacle for picking is a shallow tray or carrier, holding four or six of the ordinary quart or pint berry-boxes. Some pickers like legs, ten or twenty-four inches long, placed under this tray, but, as a rule, they do not prove satisfactory.

The best market, other things being equal, is the one that is closest. Often the amateur can dispose of all his surplus, at good prices, to his neighbors and friends who will come to get them. If this cannot be done, the city or some distant market must be sought. Red berries are usually marketed in pint boxes, while black-caps may be put either in pints or quarts. They are sent to market in cases holding from 16 to 32 boxes.

Berry or fruit growers' associations should be formed in every community where the business will warrant. Such associations aid the producers in securing the best results. Occasionally isolated growers ship their berries for considerable distances in “pony refrigerators.” These hold 54 quarts, are iced at the beginning of the journey, and on the way, if needed. When empty they are returned to the owner, to be used again.

Varieties—Varieties will differ with different localities, different soils and markets. The number of varieties grown should be limited, even in berry-growing districts. Each district should grow the sort for which it is peculiarly fitted. This should be regulated by a conference of the proposed growers, and by a spirit of co-operation.

The following are among the more popular varieties:

Red: Cuthbert, Marlboro, Miller, King. For cold climates, Sunbeam, Ironclad and Loudon will prove better able to withstand low temperatures.

Black-caps: Kansas, Older, Gregg, Plumb Farmer, Nemaha, Conrath, Cumberland.

Purple-cane: Columbian is most grown.

Everbearing: St. Regis.

Pests—There are several more or less troublesome pests of the raspberries. The following list gives the more common ones and brief directions for their control. For detailed description and control methods refer to Book IX.

Insects—Cane borer: Burrows in canes, causing swellings or enlarged areas. Cut out and burn affected canes.

Sawfly: Eats elongated holes in the leaves. Usually this is not very troublesome. Spray with poison.

Diseases—Anthracnose: Appears as elongated light spots on canes. It weakens canes and if very bad may cause death. Prune out badly infected canes. Spray new canes with Bordeaux mixture.

Crown Gall: Causes excrescences and swellings at base of canes and at times along cane. Remove and burn infected plant.

Orange Rust: Appears as bright orange discolorations on lower surface of leaves. Remove and burn plant.

Cane Blight: Causes wilting of cane from tip downward. Cut out infected canes and burn. If severe remove and burn plant.

Blackberries and Dewberries

These fruits are very similar so far as the character of fruit produced is concerned, but usually very different in plant characteristics. The blackberries for the most part are upright growers, while the dewberries have trailing canes.

Treated Like the Raspberries—Propagation—except for the dewberries—is similar to that of the suckering type of raspberries.

The soil requirements as to location and preparation are essentially the same as for the raspberry. It may be added that the blackberry likes a heavier soil with a clayey loam character that holds moisture well. This is perhaps more important than with the raspberry.

The planting, cultivation and pruning are the same as for the suckering raspberries. Some growers practice summer pruning when the new canes are about two feet high. It is desirable to practise some form of tying,

staking or trellising for blackberries. Blackberries are commonly marketed in crates carrying from 24 to 32 pint boxes. The pint box is now more extensively used for this fruit than the quart box, as it enables the fruit to reach the market in better condition. The same pests are troublesome as with the raspberries.

Varieties—There are many varieties of blackberries from which selections must be made to meet local conditions. The Ancient Briton, Snyder and Eldorado are very commonly grown.

Currants and Gooseberries.

The currant and the gooseberry are northern fruits, and attain their greatest development and productiveness in the northern states. They will grow and produce in almost any soil and location, even under the grossest abuse and neglect; yet, they respond magnificently to good treatment and choice situations.

Currants—Experience has shown that, to secure the choicest and most abundant product, this fruit must have a moist, cool soil. The best results are secured on strong clay loam, or even on stiff clay, if it is in a good state of cultivation. A cool northern exposure is best; and comparatively low, moist ground, with some shade, will often be most desirable. This fact makes the currant suitable for planting in young orchards.

A dozen plants will furnish sufficient fruit for the ordinary family. They will bear in almost any situation; but, keeping in mind that they should not be allowed to grow in weeds and grass. Large quantities of barnyard manure should be worked into the soil before and after setting the plants. Its decomposition furnishes the humus to retain moisture and provide abundant available plant food. The berries are larger and sweeter, and there is in no way any harmful effect as is the case when much manure is applied to many of our other fruits.

Plants—The plants may be grown from cuttings of the ripened wood or from layering. The cuttings are made from the current season's wood, in August or September after the leaves have fallen, or early the following spring. The cuttings should be 7 or 8 inches long and planted in well-prepared garden soil. They should be set 4 inches apart, in rows 3 feet apart, and deep enough so that only the upper inch is above the surface of the soil. If set in the fall, by winter root-growth will have started, and in the spring they will start off and grow strongly. They should be kept well cultivated in the growing season, to conserve the moisture. The young plants are sometimes planted when one year old, but best results will be obtained by allowing them to grow for two seasons before setting them in the plantation.

The branches may be rooted by bending them down and covering with soil, leaving the tips exposed. After one season they should be cut loose, lifted, and grown in nursery rows for one season before being planted out.

They are also layered successfully by cutting off the clump, encouraging as many young shoots as possible, and then mounding soil in and about them to a height of 8 or 10 inches. The second spring the soil may be moved and the rooted shoots treated as in the preceding paragraph.

Usually the grower will secure his plants from a nurseryman. Buy two-year-old plants, one-year olds are a little cheaper, but the difference in price does not warrant using the younger plants.

Planting — In large plantations the best system of planting is the hill system. Use a single plant to establish a hill, and plant 6 by 6 feet for best results. Where continuous rows are used, the plants should stand $3\frac{1}{2}$ or 4 by 6 feet.

Cultivation and Mulching — The currant must not be cultivated deeply, for it is a shallow-rooted plant. The necessary moisture must be maintained by continual surface cultivation, or by mulching.

Ashes, sawdust, straw and manure are used for mulching purposes. Hardwood sawdust is frequently used, but it should not be worked into the soil. Apply to a depth of several inches. Manure is good, and tends to keep a supply of plant food always at hand. The best method of mulching is to confine the application to the hills, and within the row, where the continuous row is used. The space between the rows is then kept cultivated.

Pruning and Thinning — The plants produce the fruit at the base of strong one-year-old canes and on short shoots, known as spurs. The larger portion of it is produced on the two and three-year-old wood. Somewhat larger fruits are borne on the two-year, but more of them are borne on the three-year wood. On older wood, the size is decreased to such an extent that it is not desirable to retain the wood longer. Pruning, therefore, consists in cutting out wood over three years old, reducing superfluous new canes and cutting back those which are left.

In field culture, four to eight main stems are usually allowed to develop.

Harvesting and Marketing — Currants should never be stripped when picking. The stems of the bunches should be cleanly severed from the branches. Only in this way will they keep for shipping, or for display in the market-place, and even for home use it is the more satisfactory method. Currants are largely used for making jelly. They are said to make a stiffer and better jelly when picked just as the currants are ripening, and while the fruits on the tips of the bunches are yet green. They are usually marketed in the ordinary quart boxes, but some dealers prefer them in grape or nine-pound baskets.

Pests — Currant aphid and currant worm are the most troublesome pests of this fruit. The former causes the curling and reddish discolorations so often seen on the leaves. Spray with strong contact insecticide just before buds open or with a weaker contact insecticide before leaves begin to curl badly. Watch the plants closely and spray with a poison when the currant worm appears.

Varieties—The following varieties are popular: White Grape, Victoria, Long Bunch Holland, Pomona, Red Cross, Perfection, London Market, Fay's Prolific, Wilder, Cherry and LaVersailles. The varieties of black currants most grown are Black Champion and Black Naples.

Gooseberries—The gooseberry is closely related to the currant. Therefore, the location, soil treatment and cultivation are very similar to those for the currant. It is largely used green for sauce, for pies and for canning. For jam and preserves it is usually preferred ripe.

The cultivated sorts are derived from European sources, the native wild species, and hybrids of these species. Those of European and hybrid species bear larger fruits, but are more susceptible to mildew. The mildew can be controlled by proper cultural methods which makes it possible to grow these types, where formerly it was considered an impossibility. The culture of the gooseberry is practically identical with that for the currant. Pruning is usually not followed as systematically, but for best results the plants should not be allowed to become too dense. Pickers should wear leather gloves when harvesting the crop. The berries are either picked or raked off with the fingers. If the latter method is followed, they must be run through a fanning mill to remove leaves and other refuse. As the berries are usually harvested green, this treatment will not injure them for market purposes. Some pickers use a stick to spread or hold the bushes apart. They are marketed in ordinary quart berry boxes, although in some localities the large English sorts are packed in ten-pound trays. When so packed, they may be faced in the receptacle the same as are the large western sweet cherries.

Varieties—Houghton, Downing, Champion, Pear and Carrie of American sorts; and Chautauqua, Industry and Smith Improved of the European type are among the best varieties.

Pests.—The currant worm is probably the most serious pest of the gooseberry. Treatment is the same as when it attacks the currant. Mildew is likely to be a serious trouble on gooseberries, especially on European and hybrid sorts. Where the latter sorts are grown, frequent and thorough sprayings with Bordeaux mixture or lime sulphur are necessary to insure salable fruit and to keep the plants healthy.

BOOK V
CONCRETE CONSTRUCTION

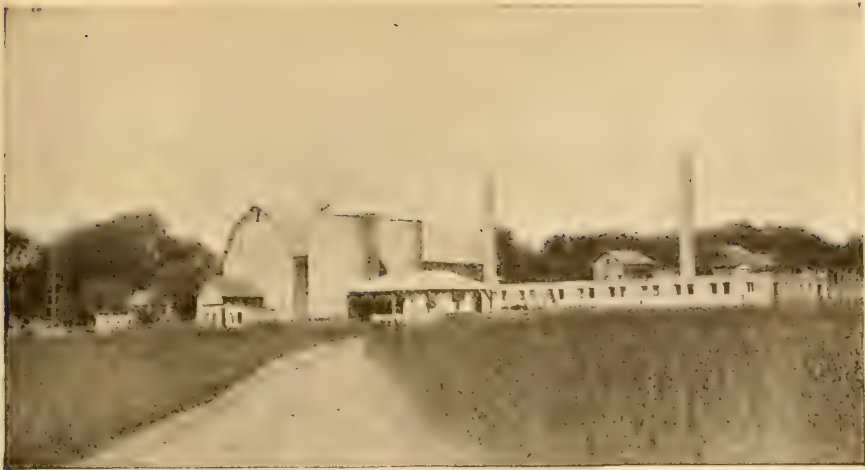

Concrete Dairy Barn, Hay Barn, Silos, Milk House and Manure Pit. The Dairy Barn is the Low Structure to the Right of the Illustration, and is Ventilated by Means of Two Concrete Stacks.

CONCRETE CONSTRUCTION

CHAPTER I.

CONCRETE AND ITS CONSTITUENTS

- I. ADVANTAGES OF CONCRETE. II. PORTLAND CEMENT. III. AGGREGATES—SAND—WASHING SAND—GRAVEL. IV. NATURAL MIXTURE OF BANK SAND AND GRAVEL. V. WATER.

The Advantages of Concrete—In the past, the most common, convenient and cheapest form of building material on the farm was lumber. With the rapid decrease of the timber supply and the resulting increased price of lumber, there has come in farming communities, a necessary demand for a new building material. In concrete, the farmer has found the material that suits his needs, for although concrete structures generally are higher in initial cost, their durability or permanency, their fire-proof character and their sanitation, make them the cheapest and most desirable in the end. This fact warrants the prevalent and increasing use of concrete in rural districts.

To give in a simple and clear way, the best methods of handling and using concrete, and to illustrate and describe special plans for floors, walks, troughs, tanks, posts, and other farm conveniences, shall be the aim and purpose of this discussion.

It is estimated that the average life of a farm building is about thirty-three years. At that rate the annual percentage for maintenance of a building is 3 per cent, or one thirty-third of the original cost.

Suppose a building cost \$2,500. The average annual expenditure to prevent its dilapidation would be one thirty-third of \$2,500, or about \$75.75. The total cost, omitting interest at the end of thirty-three years, would be \$5,000.

Assume on the other hand that the farmer had constructed a concrete building of the same size at the cost of \$3,500. This building, it is safe to say, if properly constructed, would last at least one hundred years. At the end of thirty-three years the building, not including interest on investment as above, would cost \$3,500 plus \$1,123 in depreciation, in all \$4,623; or \$475 less than the frame structure.

Other farm structures such as barn floors, tanks and walks, depreciate much more rapidly than buildings, and will have to be replaced about every five years. Thus it will be seen that for only a short period, it would pay the farmer to make these special structures of concrete even at four times the cost of lumber.

The fire-proof character of concrete should always be considered by the farmer who contemplates building. Statistics show that fire loss in the United States and Canada during a single year was about \$20,000,000. This does not include the enormous amount of inconvenience and loss of time that occurs as indirect results of fire. The value of concrete as a protection against fire loss on the farm cannot be over emphasized. There are numerous instances where frame barns have been completely destroyed while silos of concrete, together with their contents, have been well preserved.

Much loss of corn, grain and feed by rats, mice and other vermin is experienced by every farmer. This needless waste can be largely prevented by making foundations and floors of concrete. The ease with which all floors whether in barn, dairy or cellar are kept clean and sanitary when made of concrete is another very important point in its favor. Concrete improves the appearance of a farm and hence increases its value. Its intelligent use is a real factor in bringing the farm up to maximum efficiency.

The Composition of Concrete — Concrete, which is an artificial stone, is made by mixing together Portland cement, sand, stone (or gravel) and enough water to make a mushy mixture about like thick cream. Various proportions of each are used depending on the use to which concrete is put. The water coming in contact with the cement causes the latter to begin to harden in about half an hour. In from six hours to a day, the mass is hardened so that a dent cannot be made with the hand; in a week the entire mass becomes apparently one hard stone, but the hardening process in reality continues for months.

Before taking up the processes of proportioning, mixing and placing concrete, it is essential that we have a clear understanding of the materials with which we are to work and what we must look for in selecting these.

Portland Cement — This material is handled commercially in barrels, paper bags and cloth sacks, the latter being used almost exclusively because of convenience in handling and because they can be returned to the manufacturer to be refilled. A sack of cement weighs 95 pounds, and four sacks make a barrel of 380 pounds.

It is of the utmost importance that cement be stored in a dry place. Once wet it becomes hard and lumpy, and the lumps which are useless must be thrown out. If, however, the lumps are caused by pressure in the storehouse, the cement is perfectly safe to use. In storing cement lay wooden blocks on the ground. Then place on these blocks, dry boards on which place the cement, and cover it with a canvas or roofing paper. Never, under any circumstances, place the cement next to the outside wall of a building, on the bare ground or cement floor. Always keep it in a dry place regardless of other conditions, as moisture is the only element injurious to its quality.



Concrete Block Farm Residence with Other Concrete Improvements.

The number of brands of Portland cement sold in this country exceeds two hundred. It is essential therefore that not only Portland cement is used but that it is a brand which has been tried, tested, and found to give best results.

It must be remembered that cement merely binds the sand and stone together to form concrete. It is evident, therefore, that good cement will not make good concrete, if first-class sand, crushed rock or other material is not used. On the other hand, the best and cleanest sand or stone will not make good concrete if a low grade of cement is used. In either case it is true that the best is the cheapest in the end.

Aggregates — These are any materials used with cement to form concrete. The aggregates must be clean and strong. Dirt is a sign

of weakness. See that the materials you use are clean; for organic matter, mud, clay or other fine material mixed with the cement prevents it from coming in contact with the surface of the sand and stone or gravel, thus lowering its binding capacity.

As a chain is not stronger than its weakest link so concrete is not stronger than its weakest aggregate. It is important, therefore, that only material of good quality be used. Some sand and gravel contain shale-like particles which after exposure to weather for a short time, disintegrate. Sometimes stone of a chalky nature is used which of course does not give good results. The farmer should insist on getting only first class material.

Sand—A good coarse quality of sand is desirable. Very fine sand is objectionable because the finer the particles, the more cement must be used to get concrete of a desired strength. A graduated sand, containing both coarse and fine particles, with an excess of the coarse, is best. It has been found that double the amount of cement ordinarily required is needed with fine sand. For example, instead of using a concrete of one part cement, two parts sand, and four parts gravel, two parts cement must be used with the above amount of sand and gravel. Use, therefore, a coarse sand. It will save you lots of cement. Besides being coarse, sand should be clean. While in many localities sand is of very good quality, places exist where farmers have difficulty in securing sand fit for concrete work.

The question then arises, how to determine whether or not sand is clean. The presence of dirt, clay, or organic matter can be determined by rubbing a little in the palm of the hand. If a fine sticky residue remains after rubbing, the sand should be further tested by taking a little of this sticky material between the teeth. If not gritty or sharp, it contains very fine clay or vegetable loam which is bad. This test must be made with moist sand as it is taken from the bank, because dust will not adhere to the hand if dry. A further test for sand is to examine its general appearance. If it looks "dead," an appearance which is caused by particles of dirt sticking in little lumps to the sand grains (sometimes also making little bunches of sand stick together when picked up), foreign material is present. For a more reliable test, fill a tumbler about one-fourth full of sand and add twice as much water. Shake it well and let it stand until settled. The sand will deposit first and the clay or loam will form a layer over it. Measure this layer and if it is greater than 6 per cent, wash the sand or do not use it.

How to Wash Sand—If clean sand is not obtainable, sand can be made usable by washing. The American Association of Portland Cement Manufacturers gives the following method—Build a loose board platform from 10 to 15 feet long, with one end a foot higher than the other. On the lower end and on the sides, nail a board or plank 6 inches wide, on edge, to hold the sand. Spread the sand over this platform in a layer three or four inches thick and wash with water, either by means of a hose or

bucket. The washing should be started at the high end, and the water allowed to run through the sand and over the two-by-six inch piece at the lower end. A small amount of clay or loam does not injure the sand, but any amount over 5 per cent does.

Gravel—Stone or gravel is known as the “coarse aggregate” of concrete. Great care should be used in its selection. The pebbles should be closely inspected to see that there is no clay on their surface. A layer of such clay prevents the binding of the cement. If necessary, stone or gravel may be washed in the same way as described for sand. Indeed, it is more easily done than sand, as the water flows through the larger voids in gravel more readily than through the voids in sand. Dust may be left in the crushed stone without fear of its interfering with the strength of the cement, but care should be taken to see that such dust is distributed evenly through the whole mass, and when dust is found in the stone, slightly less sand should be used than usual.



Burned Barn Showing Concrete Building in Rear in Which the Lead Traps on the Sinks Were Not Even Melted Off.

As to the size of stone or gravel, this must be determined by the form of construction contemplated. For foundations or any large thick structure use anything from one-half inch in diameter to stone one half the thickness of the wall. The larger stones, however (those more than three inches in diameter), must not exceed one-third of the total coarse aggregate. Keep the larger stones to the center of the wall if possible. The bottom layers can be nearly all large stones. For thin walls, six inches or less, use from one-fourth to one-inch stone.

The best results are obtained by the use of a mixture of sizes graded from small to large. By this means the spaces between the stones or pebbles are reduced, and a more compact concrete is obtained. Moreover, this method makes it possible to get along with less sand and less cement.

Natural Mixture of Bank Sand and Gravel—It frequently occurs that natural bank sand and gravel is to be had with the right proportions

of the various aggregates for concrete work. Generally, however, an excess of fine material predominates, so that the farmer must exercise great care in using this material. Unless the mixture runs very even throughout the bank, and contains the right proportion of sand to gravel, and unless the men in charge of the mixing are competent to determine the right strength of the "batch" by its appearance, it is recommended that the gravel be screened out of the sand, and the two mixed separately in the desired proportions. If, however, only sand can be obtained from the bank near by, a good concrete can be made by using a little more cement. It is often found that fairly good-sized stones ranging in size from a hen's egg to six inches in diameter can be had, and these mixed with the sand and cement just spoken of make what is called a rubble concrete. Such walls are very common for barns and residences, and any structure of minor importance. It is not to be recommended for high walls or for bridge supports, etc., unless it be a very heavy wall or pier. The amount of cement to use with the sand would be in the proportion of about 1 to 4. If the sand is exceedingly fine, increase it to 1 to 3. If coarse with some small stones or pebbles present, it could be used 1 to 5. In this work do not let the aggregate or coarse stone exceed one-half the total volume of the wall.

Water Must be Clean — Water to be used for concrete must not contain acids or alkalis. Avoid the use of water from streams into which refuse from chemical mills or laboratories is dumped, or water leached from the manure heap or barnyard. If in doubt as to the purity of the water, make a small block of concrete and observe whether the concrete "sets" properly.

CHAPTER II.

GENERAL INSTRUCTIONS FOR MIXING AND PLACING CONCRETE

- I. PROPORTIONING THE MIXTURE—RICH MIXTURE—STANDARD MIXTURE—MEDIUM MIXTURE—ORDINARY MIXTURE. II. MEASURING THE PROPORTIONS—TABLE—THE MEASURING BOX. III. HOW TO MIX CONCRETE BY HAND—FIRST METHOD—SECOND METHOD. IV. CONSISTENCY OF MIXTURE. V. COLORING—TABLES OF COLORS. VI. PLACING AND PROTECTION OF CONCRETE. VIII. REINFORCING.

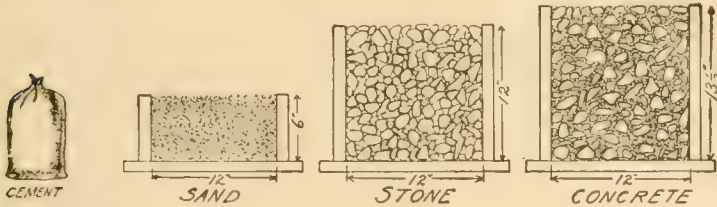

Fig. 1.—Quantities of cement, sand, and gravel in 1:2:4 concrete mixture, which means 1 part cement, 2 parts sand, 4 parts crushed stone or gravel, and the resulting quantity of concrete, which is only slightly greater in size than the gravel, the sand and cement filling the voids in the gravel.

PROPORTIONING THE MIXTURE

The proportions of cement, sand and gravel in a mixture should be such that all the voids or open spaces are filled. Because of this filling action of sand and cement, the amount of concrete made by the use of one cubic yard of gravel, one-half cubic yard of sand, and one-quarter yard of cement, is but little over one yard and not one and three-quarters cubic yards, as a person is apt to think. (See Fig. 1.) When all the voids in the aggregates are just filled with cement there is an ideal mixture. But as the voids vary slightly in each load of sand and gravel, and in order to be perfectly safe, it is well to use a little more cement than is called for. If when placing concrete with the proportions specified, a wall shows many pockets of stone or voids, use a little less stone and more sand. While on the other hand, if the mortar rises to the top in placing, use less sand and more stone in the next batch. A person with experience and good judgment can determine quite accurately the proportion of each of the concrete constituents to use for the various purposes to which it is put.

In all concrete work the mixture is composed of a certain amount of cement, a larger amount of sand, and usually twice as much gravel as sand. To determine how much of each to use one must consider the kind of work to be done.

As a guide for those who wish to build concrete structures for which specific instructions will be given later, we furnish the following

table from the Atlas Portland Cement Company showing the various proportions to be used:

A Rich Mixture — For columns and other structure parts subjected to high stresses, or requiring exceptional water-tightness. Proportion, $1:1\frac{1}{2}:3$, i. e. one barrel (4 bags) Portland cement to one and one-half barrels (5.7 cubic feet) loose sand, and three barrels (11.4 cubic feet) loose gravel or crushed stone.

A Standard Mixture — For reinforced floors, beams and columns, for arches, for reinforced engine- or machine-foundations subject to vibrations, for tanks, sewers, conduits and other water-tight work. Proportion, $1:2:4$, i. e. one barrel (4 bags) Portland cement to two barrels (7.6 cubic feet) loose sand, to four barrels (15.2 cubic feet) loose gravel or broken stone.

A Medium Mixture — For ordinary machine-foundations, retaining walls, abutments, piers, thin foundation walls, building walls, or ordinary floors, sidewalks and sewers with heavy walls. Proportion, $1:2\frac{1}{2}:5$, i. e.

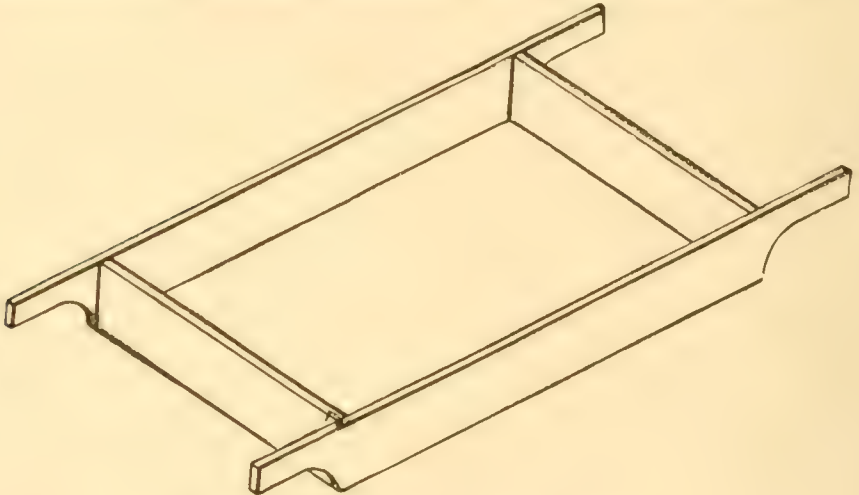

Fig. 2.—Measuring Box for Sand or Gravel.

one barrel (4 bags) Portland cement, to two and one-half barrels (9.5 cubic feet) loose sand, to five barrels (19 cubic feet) loose gravel or broken stone.

An Ordinary Mixture — For unimportant work in masses, for heavy walls, for a heavy foundation supporting stationary load, and for backing for stone masonry. Proportion, $1:3:6$, i. e. one barrel (4 bags) Portland cement, to three barrels (11.4 cubic feet) loose sand to six barrels (22.8 cubic feet) loose gravel or broken stone.

Measuring the Proportions —The proportions are always to be measured by volume. This can be done in either of two ways. A man of good judgment can fix the right proportions to use by knowing how many shovelfuls a bag of cement contains, and by adding a definite

number of shovels of sand and gravel. This method of measuring is extensively used because it is the most rapid and can be made accurate enough for all practical purposes. Others prefer the use of the so-called "measuring box." As it is more accurate, it is recommended for beginners in concrete construction. This box is made of any kind of rough boards, with straight sides, and without top or bottom. The box can be made any size, depending on the proportions of material to be used.

The following table shows the quantities of materials, size of measuring box used for various mixtures, and the amount of concrete resulting from a "two-bag batch":

TABLE No. 1

PROPORTION BY PARTS.			TWO BAG BATCH			
Cement	Sand	Stone or Gravel	MATERIALS			Concrete from mixture
			Cement	Sand	Stone or Gravel	
1	2	4	Bags	Cubic Feet	Cubic Feet	Cubic Feet
1	2½	5	2	3¾	7½	8½
			2	4¾	9½	10
Size of measuring box inside measurement			Water required medium wet mixture			
Sand		Stone or Gravel	Gallons			
2 ft. x 2 ft. x 11½ in.		2 ft. x 4 ft. x 11½ in.	10			
2 ft. x 2 ft. x 11½ in.		2 ft. x 4 ft. x 11½ in.	12½			

It will be seen from the above table that the measuring box for sand for a "two-bag batch" is two feet square and eleven and one-half inches deep, while that for stone or gravel is the same depth and width, but twice as long, in other words twice as large. Where only a small amount of concrete is to be made, it is not necessary to make a large measuring box for gravel, but the one made for sand can be filled twice in measuring the gravel.

To illustrate the use of the measuring box, let us assume that a 1:2:4 mixture is required and that the amount of finished concrete needed is about 8½ cubic feet. By referring to Table No. 1 it will be noted that 2 bags of cement are required, also 3¾ cubic feet of sand, and 7½ cubic feet of stone or gravel. Under "size of measuring box" in the table it will be found that the sand should just fill a box 2 feet square and 11½ inches deep, and that stone should fill this box twice (or a box of the same depth and width, but twice the length). Lay the sand box, or frame, on the mixing platform and fill it. Then raise the box. Empty one bag of cement on this sand. Then make the surface level. Place the gravel form on top and fill with gravel or stone; or fill the sand measuring-box twice. Empty the box by raising, and add the second bag of cement. The material is then ready to be mixed.

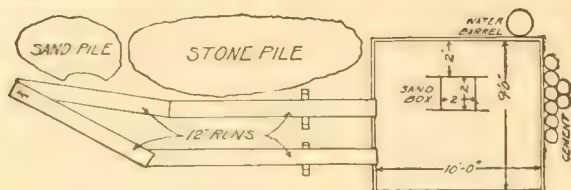

Fig. 3.—Lifting Off the Sand Measuring Box and Getting Cement Ready.

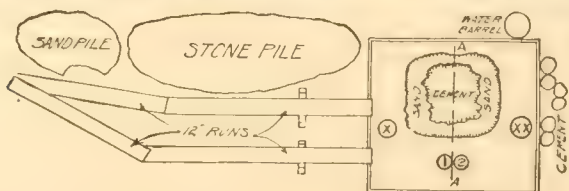

Fig. 4.—Spreading the Cement Over the Sand.

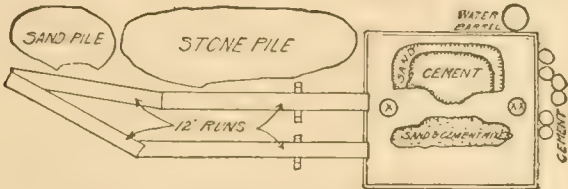

Fig. 5.—First Turning, Sand and Cement.

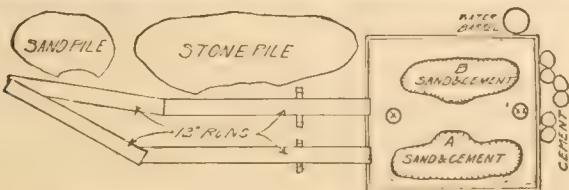

Fig. 6.—Second Turning, Sand and Cement.

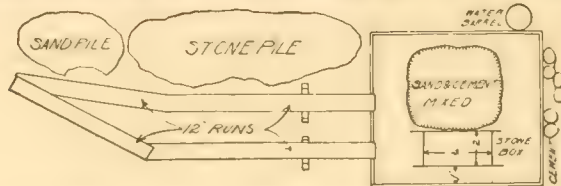
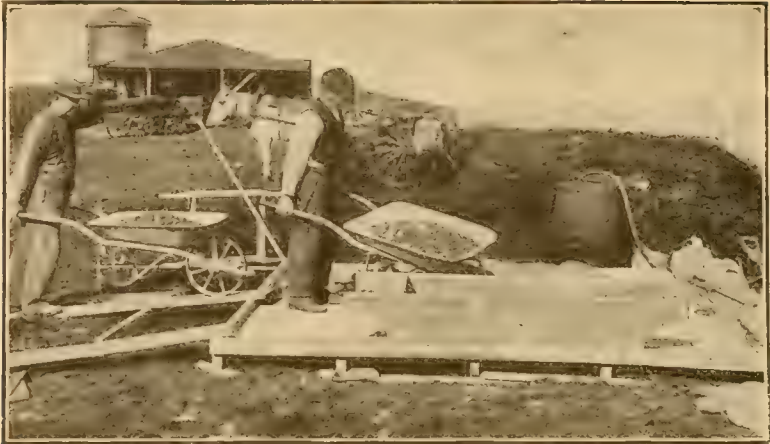

Fig. 7.—Filling the Stone (or Gravel) Measuring Box—First Method.

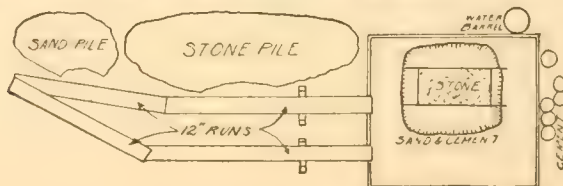
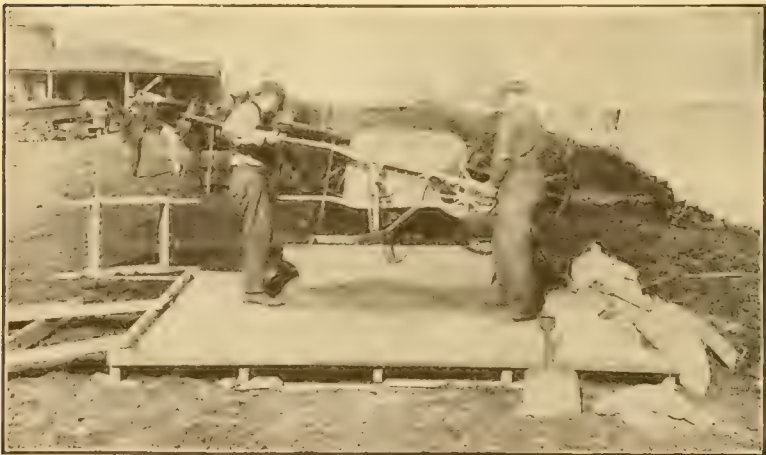

Fig. 8.—Filling the Stone (or Gravel) Measuring Box When on Top of Mixed Sand and Cement—Second Method.

From the table, the farmer can determine very closely the number of bags of cement he needs before going to town. Also the amount of sand and gravel needed, provided of course, that he knows the number of cubic feet in the structure he intends to make.

Only the approximate amount of water needed can be given because the amount will vary, depending on the wetness of the sand and the consistency of concrete desired. The amount given in the table will merely serve as a guide for the beginner, so that he may have sufficient on hand when the concrete is to be made.

HOW TO MIX CONCRETE BY HAND

First Method—There are many ways of "hand mixing," all having the same good results. The way described here we believe to be the best for obtaining good results with a minimum of labor. In this description and the accompanying illustrations we have taken as a basis a "two-bag batch" of 1:2:4 concrete. For convenience the sand pile should be next to the mixing platform. First, fill with sand the measuring box, which is placed about two feet from one of the 10-foot sides of the board as shown by the diagram in Fig. 3. When the sand box is full lift it off and spread the sand over the board in a layer 3 or 4 inches thick as shown in Fig. 4. Take the two bags of cement and place the contents as evenly as possible over the sand (See Fig. 4). With the two men at points marked "x" and "xx" on the sketch below Fig. 4, start mixing the sand and cement, each man turning over the half on his side of the line AA. Starting at his feet and shoveling away from him, each man takes a full shovel-load, turning the shovel over at points marked 1 and 2 respectively in Fig. 4. In turning the shovel, he must not simply dump the sand and cement at the points marked 1 and 2 in the diagram under the cut, but shake the materials off the end and side of the shovel, so that the sand and cement are mixed as they fall. This is a great assistance in mixing these materials. In this way the material is shoveled from one side of the board to the other as shown in Figs. 5 and 6. Figure 5 shows the first turning, and Fig. 6 the second turning.

The sand and cement should now be well mixed and ready for the stone and water. After the last turning, spread the sand and cement out carefully, place the gravel or stone measuring-box beside it as shown in Fig. 7, and fill from the gravel pile. Lift the box and shovel the gravel on top of the sand and cement, spreading it as evenly as possible. With some experience, equally good results can be obtained by placing the gravel measuring-box on top of the carefully leveled sand and cement mixture, and filling it, thus placing the gravel on top without extra shoveling. This method is shown in Fig. 8. Add about three-fourths the required amount of water, using a bucket and dashing the water over the gravel on top of the pile as evenly as possible.

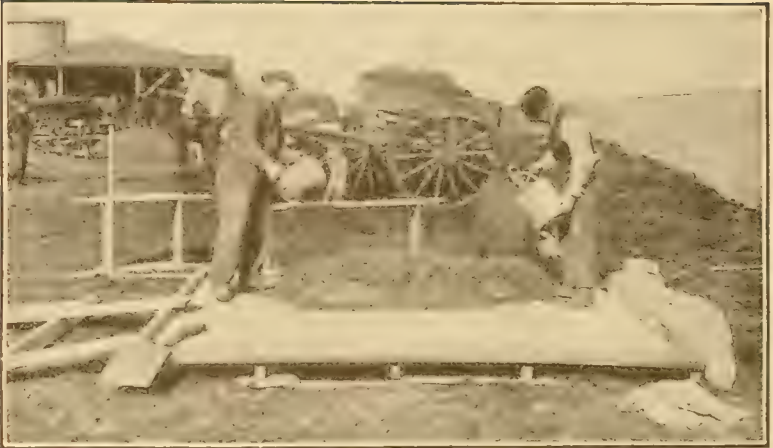

Fig. 9.—Place the Water on the Stone (or Gravel) Which is on Top of the Mixed Sand and Cement.



Fig. 10.—Mixing the Stone (or Gravel) With the Sand and Cement.

(See Fig. 9). Be careful not to let too much water get near the edges of the pile as it will run off, taking some cement with it. This caution, however, does not apply to a properly constructed mixing board, as the cement and water cannot get away. Starting the same as with the sand and cement, turn the material over in much the same way, except that instead of shaking the material off the end of the shovel, the whole shovel load is dumped, as at points 1 and 2 in the diagram under Fig. 4, and dragged back toward the mixer with the square point of the shovel. This mixes the gravel with the sand and cement, the wet gravel picking up the sand and cement as it rolls over, when dragged back by the shovel. (See Fig. 10.) Add water to the dry spots as the mixing goes on, until the required water has been used. Turn the mass back again as was done with the sand and cement. With experienced labor the concrete should be well mixed after three such turnings, but if it shows streaky or dry spots it must be turned again. The concrete is now ready for placing.

Second Method — A different method of mixing concrete which affords convenience and ease of mixing, is as follows: Instead of a mixing platform, a box 12 feet long and about $3\frac{1}{2}$ feet wide is used. The bottom is made of medium grade matched lumber with the planed side up, thus making shoveling easier. The sides are made of 2x10-inch rough plank, while 12-inch planks are used for the ends placed at an angle of about 60 degrees, thus making the ends about the same height as the sides. Three cleats made of 2x8-inch plank are placed on edge under the box, one being nailed near each end and the third under the center of the box. These are to raise the box off the ground, thus saving the mixer the extra work of stooping down for every shovelful that is turned; also making easier work for the men mixing by enabling them to stand partly under the edge of the box and shoveling under instead of ahead of them.

In making the box, secure as light lumber as possible so that it may be easily carried around from place to place for any job on the farm. A box of the above size is large enough for a two-bag batch. Two men can work to the best advantage when using a box of this size. If, however, it is desired to have a box for a one-bag batch, it can be made both shorter and more shallow. For one man working alone, it is recommended that the box be only $2\frac{1}{2}$ feet wide. This width will enable the man mixing to stand on one side of the box, and conveniently shovel the concrete on the other side of the box.

When hauling the sand put it close to where the work is to be done. The concrete mixing box can then be placed between the gravel pile and the forms so that the concrete when mixed can be dumped directly into the forms with the use of a shovel or a pail. By using a little intelligence in placing the gravel pile and mixing box conveniently, and by placing the cement just outside one end of the box, and the water barrel on the other end, the farmer will be surprised to find how much time and labor he can save in doing his concrete work.

Provided the forms, which will be described later, are in place everything is now ready for mixing. Put the required number of shovelfuls of sand for one bag of cement in one end of the box and level off with the point of the shovel. Then empty the bag of cement on this. After leveling again, shovel enough gravel for another bag of cement on top of the first and add cement as before. This is a two-bag batch. If a one-bag batch is used, add half a bag of cement when half the gravel has been placed in the box. Add the rest of the gravel and cement as before. When the batch is not too large, the most thorough mixing can be secured by starting to shovel the mixture in the extreme end of the box, letting it fall over the edge of the shovel, and letting it drop and spread over the other end of the batch. (In other words, work towards the center of the box.) Continue shoveling this way until the batch has been removed to the further end of the box. Then shovel it back in the same way and the batch will be sufficiently mixed. But if any streaks or lack of uniformity exist, it is well to shovel the batch over once more. By the use of the shovel, spread the batch somewhat evenly over the entire box. With the point of the shovel, make a few "kettle holes" or "craters" in the mixture and add the water. Let this stand about a minute to soak, after which the whole is made of uniform consistency by a few strokes of the shovel.

If the batch is large, then it can be best and most conveniently mixed by starting the shoveling at the end of the batch toward the center of the box and throwing it toward the empty end of the box until the whole has been turned over. Usually three such "turnovers" are necessary for thorough mixing. In either case the importance of thoroughly mixing the materials before adding the water cannot be over-emphasized. The drier the material, the easier it is to mix.

Consistency of Mixtures—Not all mixtures should have the same consistency. It should vary according to the use to which it is to be put. There are three kinds of mixtures in general for concrete work: (1) Very wet mixture, concrete wet enough to be mushy, running off the shovel when handled; used for thin walls or for thin sections, etc. (2) Medium mixture, concrete just wet enough to be jelly-like; used for foundations, floors, etc. (To better describe this mixture it may be said that a man would sink ankle-deep if he were to step on top of the pile). (3) Dry mixture, concrete like damp earth, used for foundations, first layer of walks, moulds, etc.

The dryer the mixture, the quicker the concrete will harden, but in the long run, when carefully mixed and placed, the results from any of the above mixtures will be identical. It may be said, however, that a dry mixture is the hardest to handle, must be protected with the greatest care from sun or from drying too quickly, and is likely—unless used by most experienced hands—to show voids or stone pockets in the face of the work when the forms are removed. The less the voids in the stone or gravel, the greater will be the volume of the con-

crete. In general, the amount of concrete will be greater in each instance than is shown in the table, especially when gravel is used.

As a matter of economy it is recommended that mixing machines be used instead of hand power.

COLORING

It is sometimes desired to color concrete work. While color is frequently used for outside finishing, it is seldom used with concrete put into moulds. The coloring matter, in proportions depending on the desired shade, should be mixed with the cement before the sand or gravel is added.

One of the most important questions, and one that is bound to arise whenever the use of coloring matter is contemplated, is that of permanency. Blacks are safe colors, as a rule, although it is better to avoid experiments with cheap black. Of blacks, the carbon blacks are preferred over the lamp blacks. Ultramarine blue, if of good quality, will hold its color for a number of years, and generally possesses the virtue of fading out evenly, when it does finally lose its color. It cannot be classed as a permanent color with blacks, brown, and ochre. Green is an unsatisfactory color because it will fade, sooner or later, when exposed to sun and water.

TABLE NO. 2.—COLORS TO BE USED IN PORTLAND CEMENT

Color desired	Commercial names of colors for use in cement	Approx. price per lb., 100 lb. lots for high-grade colors	Pounds of color to secure for each bag of cement	
			light shade	medium
Grays.....	Germantown lamp black.....	10 cents	$\frac{3}{8}$	1
Blue-black.....	Carbon black.....	8 cents	$\frac{1}{2}$	1
Black.....	Black oxide of manganese.....	6 cents	1	2
Blue.....	Ultramarine blue.....	18 cents	5	10
Brownish red to dull brick red.....	Red oxide of iron.....	3 cents	5	10
Bright red to vermillion.....	Mineral turkey red.....	15 cents	5	10
Red sandstone to purplish red.....	Indian red.....	10 cents	5	10
Brown to reddish brown.....	Metallic brown (oxide).....	4 cents	5	10
Buff, colonial tint and yellow.....	Yellow ochre.....	6 cents	5	10

Reds and browns need little comment in addition to the explanation given in the Table of Colors. These colors are permanent if of high grade.

Yellow ochres are of a wide variety in shade and quality. French ochre, if genuine, is safe to use, and with it most attractive colonial yellow and buff tones can be secured. American yellow ochres of good quality are high priced. In purchasing colors, know the name and reliability of the manufacturer before buying, and also whether the color was especially designed for coloring cement.

PLACING AND PROTECTION OF CONCRETE

No time should elapse between the mixing and placing. Directions for placing must necessarily be general, and the farmer must use his

own judgment in handling this part of the concrete work. These are the important things to remember: (1). The cement and mortar make the mass begin to harden or stiffen in about half an hour, after which time any disturbance (before the concrete is completely set) will lessen the binding power of the cement. (2.) The materials must be handled so that the constituents do not separate in placing. If the mixture is dropped from some distance or if water stands in the moulds, there is danger of the separation of constituents.

The concrete may, as previously stated, be shoveled or carried directly into the moulds by pails, or it may be shoveled into wheel-

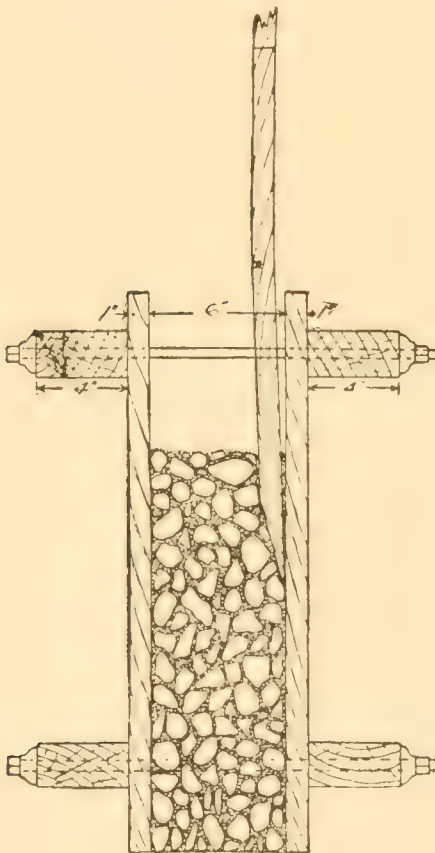

Fig. 11.—Concrete Placed in the Form.

barrows, wheeled and dumped into the moulds. Directly after placing, if the mixture is not very soft or mushy, it should be "tamped" lightly to prevent the formation of voids or stone pockets, in other words, to get a compact concrete. This compacting is also done by spading next to the form on the side where the finished concrete will be exposed to view. Spading consists of working a spade or a beveled board between the concrete and the side of the form, moving it to and fro, and up and down. This spading forces the stones away from the form so that the exposed surface, when the forms are removed, will present a smooth, even appearance. Wet the concrete frequently after placing, as concrete gains its greatest strength during the hardening or setting process, which lasts about two weeks or more. The concrete should be sprinkled at least twice daily for four or five days, during which time the forms should remain for protection against sun and wind.

Boards or canvas can be placed on top for protection in case of hot dry weather. In damp cloudy weather little or no sprinkling, and no cover is needed. The concrete should also be protected from freezing as this not only retards setting but also dries out the concrete before properly set.

REINFORCING

Reinforced concrete is concrete in which iron or steel bars or wire is imbedded. Reinforcement is required where the concrete such as in floors, beams, posts, and tanks, is liable to be bent. The fact that concrete, though very strong, is rather brittle, makes iron or steel very valuable in rendering support to the concrete when subjected to heavy pressure. Steel is tough and elastic. In modern construction the elastic property of steel and the strength of concrete are made use of by combining the two into what is called reinforced concrete.



Reinforcing.

On the farm the most common form of reinforcement is old chicken netting and barbed or fence wire. In concrete work the farmer can utilize to good advantage all odds and ends of barbed wire or other steel and iron. It is not necessary that the wire be galvanized, for the concrete protects it from rusting.

For the sake of economy the smallest amount of metal consistent with the desired strength must be used. For this reason, it is necessary to place the reinforcement near the surface, where its strength is used to best advantage, with only enough concrete outside to form a protective covering. In a fence post, for instance, the wire must be placed close to the side from which pressure is apt to occur, or in beams or slabs, it must be placed close to the bottom. Smooth wire is not to be recommended because it is apt to slip in the concrete.

The proportions for all reinforced concrete work should be approximately 1:2:4, that is, one part Portland cement, two parts sand, and four parts gravel or broken stone. The consistency of concrete to be reinforced should be about like heavy cream.

CHAPTER III.

MAKING THE FORMS

- I. MATERIALS. II. REQUIREMENTS OF A GOOD FORM. III. PLANS FOR FORMS.
IV. SELECTION OF LUMBER. V. HOW TO CLEAN AND PREVENT CONCRETE FROM
STICKING. VI. TOOLS AND OTHER APPARATUS.

Concrete is a plastic material and before hardening takes the shape of anything in which it is placed. Naturally, the building of the form is a most important item in the success of the work. This form holds the concrete in place, supports it until it has hardened, and gives it its shape, as well as its original surface finish.

Materials—Almost any material which will hold concrete in place will serve as a form. Concrete foundations for farm buildings require shallow trenches up to the ground line, usually the earth walls are firm enough to act as a form. Moulds of wet sand are used for ornamental work. Frequently colored sand is used for this purpose and provides both the finished surface and color to the concrete ornament. The two most common materials for forms are sheet metal or iron, and wood. Metal forms are used where an extremely smooth surface is desired without any further treatment after the forms are removed. Moreover, the metal forms have the advantage of being more durable and more easily cleaned.

Wooden forms are most extensively used on the farm because they can be adapted to a wider variety of usage.

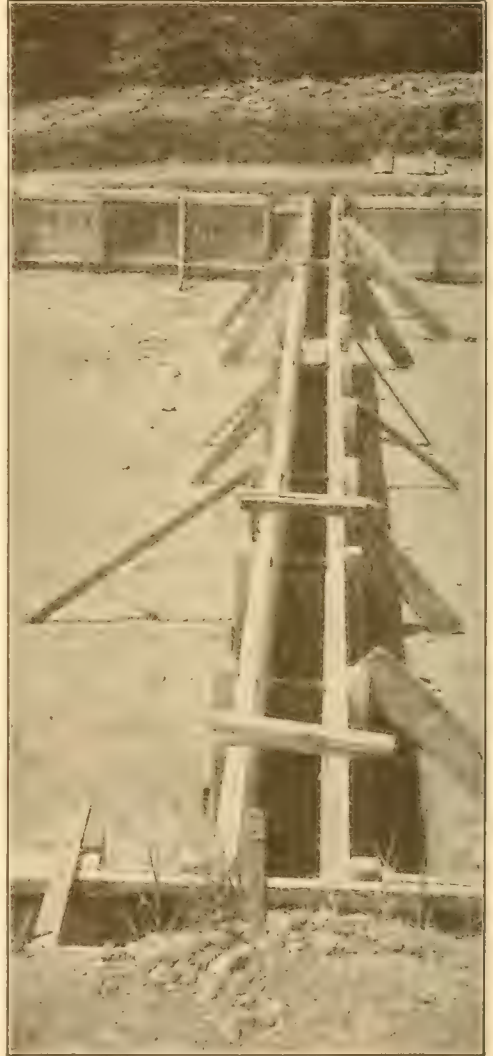

Fig. 12.—Wiring Forms Prevents Bulging.

Requirements of a Good Form — Plan your forms so that there will be no difficult measurements to understand. Make as few pieces of lumber do the work as you can, and do not drive the forms full of nails, making it difficult to take them apart without splitting. Forms must be strong enough to hold the concrete without bulging out of shape. When they bulge, cracks may open between the planks, and the water in the concrete, with some cement and sand may leak out. This weakens the concrete and causes the formation of hollows in the surface which have a bad appearance after the forms are removed. Forms which lose their shape after being used once can hardly be used again. It is, therefore, essential to make forms that are to be used more than once strong and serviceable. A little extra care in construction will save much time and prevent inconveniences later. A part of the erection cost of forms is saved if they are built in as large sections as can be conveniently handled. This saving applies to their removal as well as to their erection. Consequently the lightest forms possible with the largest surface area are the most economical.

Plans for Forms — The first consideration in planning forms is the use for which they are to be put. Neglect of this point means waste of money and time. If they are for work which is to be covered with a veneer coat, the finish of the surface is of small consideration, while the alignment of the form is all important. On the other hand, if a tank or retaining wall is to be built, the fact that the forms are not in exact alignment will hardly be noticed. Money and time can be saved, however, if the forms are accurate in alignment and well surfaced.

As mentioned above, in planning forms to be used several times, the more nearly perfect they are the more often they can be used and the cheaper they become. If forms are to be used only once, as is generally the case on the farm, they should be nailed so that they may be readily taken apart, and the lumber used for something else. If used only once, the boards should not be cut more than can be helped. If, for instance, you are building a rectangular tank eight feet by ten feet and you have only twelve or fourteen-foot lumber, run the boards of the outside wall out at each corner. This will prevent cutting and the lumber can be used for other purposes. For forms to be used only once, drive the nails in only part way.

Selection of Lumber for Forms — The selection of lumber for forms is worthy of note. If the forms are to be used several times, the use of surfaced lumber, matched, tongued and grooved, and free from loose knots is economical. If, however, they are to be used only once, and if the smoothness and evenness of surface is of minor importance, almost any kind of board or plank will do. Forms with bad cracks or knotholes may be made tight by filling them with stiff clay or mud and tacking a strip over the crack on the outside of the form. Green lumber is better than kiln-dried or seasoned material, as it is not so apt to warp when it

comes in contact with the wet concrete. Moreover, the shape and tightness of the form is less liable to be damaged.

How to Clean and Prevent Concrete "Sticking"—Particles of concrete often stick to the form. In order to prevent this, give the surface next the concrete a coat of oil or soft soap. Linseed, black or cylinder oil may be used. Never use kerosene.



Fig. 13.—Tools Used in Making Concrete On the Farm; a, Rake; b, Wheelbarrow; c, Wooden Float; d, Square-Nosed Shovel; e, Round-Nosed Shovel; f, Bucket; g, Water Barrel; h, Gravel Screen; i, Tamper.

Before erecting, or afterwards, if the forms are small and easy to get at, paint or soak them with oil. When removing the forms after the concrete has set, immediately clean off all particles of concrete that stick to the surface. A hoe or shovel will take off the most of it, while a wire brush is most effective in finishing. It is not necessary to repaint each time except the spots where the surface has a dry appearance.

Tools and Other Apparatus—One advantage of concrete over other

forms of construction is that most of the tools and other equipment necessary, are used for other purposes on the farm so that little or no apparatus need be bought.

The quantity of tools needed will, of course, vary, depending on the number of men working, the kind of concrete work to be done, and the distance between the gravel and sand pile, the mixing platform, and the concrete forms. If for instance, the mixing platform can be placed near the forms and the aggregates dumped near by, a wheelbarrow is useless; or if foundations are to be built, the materials need not be screened, and a gravel screen is not needed. The following list contains the necessary tools and equipment for two men doing general concrete work on the farm by hand:

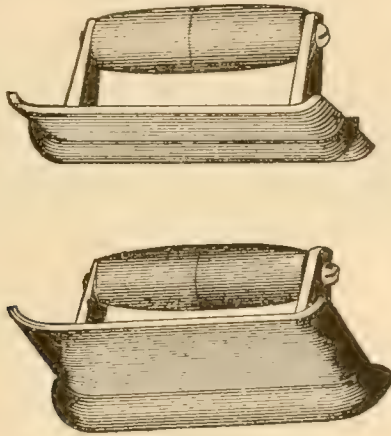

Figs. 14, 15.

- Two No. 3 square-pointed shovels.
- One wheelbarrow. (Iron body preferred.)
- One water barrel.
- Two or three pails or buckets.
- One mixing platform or box.
- One wooden float or trowel. (For surface finish.)
- One edging tool. (For edging walks, etc.)
- One jointer. (For dividing walk or floor into sections.)
- One sand screen.
- One garden spade or wooden spading tool.
- One tamper.
- One measuring box.
- Wheelbarrow "runs."

The latter should lead from the mixing board to the spot where the concrete is to be placed. Make runs smooth and if they are much above ground, twenty inches wide. This one feature will lighten and quicken the work to a remarkable extent. They are especially useful where the ground surface is rough or wet.



Feeding Floor at Columbus, Ohio.

CHAPTER IV.

THE CONSTRUCTION OF CONCRETE FLOORS, WALKS AND OTHER PAVEMENTS

- I. USES OF CONCRETE ON THE FARM. II. ADVANTAGES OF CONCRETE FOR FLOORS AND WALLS. III. PREVENTING UPHEAVAL AND SCALING. IV. SIDEWALK CONSTRUCTION—ONE-COURSE WORK—TWO-COURSE WORK—EXCAVATION AND PREPARATION OF SUB-GRADE—THE SUB-FOUNDATION—DETAILS OF CONSTRUCTION—PLACING. V. THE "ALTERNATE SLAB" METHOD. VI. ALLOWING FOR EXPANSION. VII. TABLE OF MATERIALS FOR 100 SQUARE FEET OF CONCRETE. VIII. FLOORS AND OTHER PAVEMENT—PREVENTING SLIPPERINESS.

Uses of Concrete on the Farm—Having discussed the methods of making and handling concrete, in a general way, we shall now consider the construction of a few of the main things of which the farmer today is more or less in need. In the instructions here given, considerable assistance will be obtained by referring to the illustrations accompanying the text.

The Advantages of Concrete for Floors and Walks—Because of ease in handling and placing the material, because of the durability of the finished work, and because of their comparatively low cost, concrete floors, walks and pavements are rapidly displacing those of other materials. The advantages of concrete for the above uses are especially noticeable in floors because of its water, fire and vermin-proof character; and because it is easily kept clean, and hence is sanitary. The descriptions given are economical and practical methods of laying walks.

floors and other pavement, easily adapted to any use where concrete is found advantageous.

Permanency and durability are two of the qualities which can be obtained in concrete pavement construction. In order to secure them we must observe these precautions: Cement concrete expands and contracts by changes in temperature the same as steel; it is necessary to allow for this expansion by cutting through the entire thickness of the concrete at frequent intervals. The concrete is, in other words, cut up into blocks varying in size from one and one-half to six feet square. While the latter sizes are more subject to cracking by upheaval from frost, they are more desirable for most purposes, because they are not so easily displaced or disturbed as the smaller blocks. Unless the pavements are large, and to be used for carrying enormous loads, reinforcement is not generally used. For ordinary sidewalk construction, or for most floors and other pavements used on the farm, reinforcement is not needed.

Preventing Upheaval and Scaling—The upheaval by frost can be prevented by making a foundation of crushed stone, hard furnace cinders, or any other hard porous material that can be well drained. Room is in this way provided for the expansion of ice. The above materials are not always available on the farm. The walks and pavements can then be laid directly on the ground, but good drainage must be provided. Clay soils, especially, have the power to hold a large amount of water. Ice is formed during freezing weather and the walk is upheaved. Sometimes it becomes necessary to lay walks past trees in which case all roots within one or one and one-half feet should be cut, thus avoiding upheaval when the roots grow larger. The formation of the so-called "settlement cracks" can be prevented by thoroughly tamping the ground before placing the concrete.

Crumbling or scaling of concrete surfaces can be avoided by the use of good materials, sand, gravel and cement, by properly mixing these materials, and by keeping the surface in a moist condition until the concrete has hardened. If the latter precaution is not observed the surface will become loose and chalky and will, sooner or later, scale off.

SIDEWALK CONSTRUCTION

During recent years, concrete for walks has practically displaced all other materials, and is today recognized as making the cleanest, most attractive, and the most durable kind of a walk. For these reasons the modern farmer is beginning to realize its value as a means of connecting the barn, the milk-house, the woodshed and other farm buildings with the house. There are two general types of concrete paving — one-course and two-course work.

One-Course Work — Single-course pavement is usually made five inches thick. Proportions for this should be 1:2:3. Concrete for a

single course should be mixed to such a consistency that enough mortar will rise to the surface on light tamping to permit of finishing with a wooden float.

Two-Course Work—For two-course floors and pavements, a concrete base of about four inches thick, mixed 1:3:5 (that is, one sack of cement, 3 cubic feet of sand, and 5 cubic feet of gravel), is first

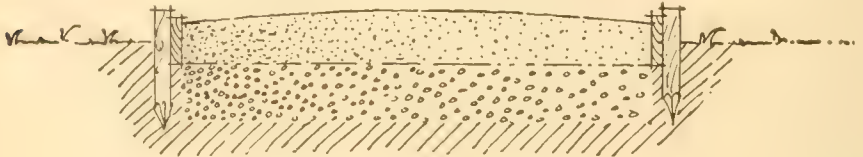

Fig. 16.—One-Course Work.

placed in the forms. This concrete is mixed to such a consistency that the water will just flush to the surface under light tamping. A three-fourths or one-inch top coat of cement mortar mixed 1:2, should be placed on top of the concrete base before it has had time to harden. Preferably this surface coat should be placed within one hour after the first concrete, or base, is made.

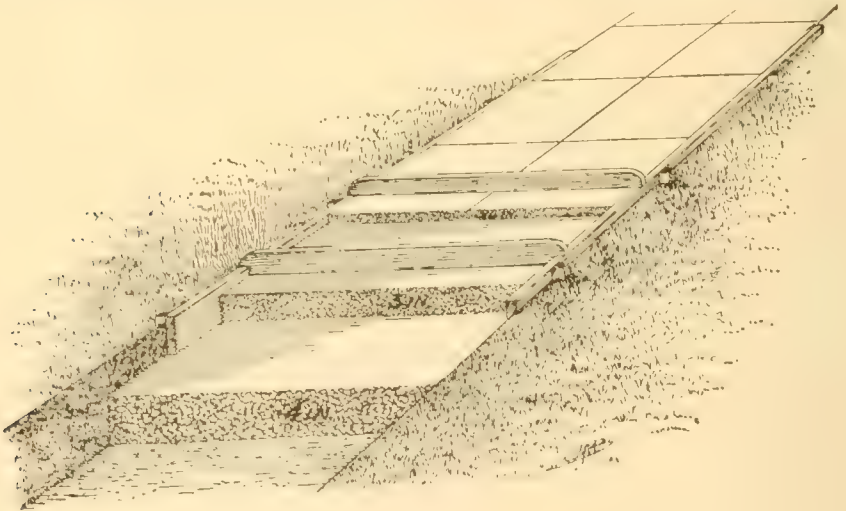

FIGURE 17

The construction of a two-course walk is shown in Fig. 17.

Excavation and Preparation of Sub-Grade—The depth of excavation will depend upon climate and the nature of the ground. It must be deeper in localities where heavy frosts occur, where the ground is moist, or where the ground is soft. If these conditions exist, the excavation should be carried to a depth of twelve inches, otherwise, four to six inches is sufficient.

The Sub-foundation — This consists, as previously stated, of a porous layer of such material as broken stone, gravel or cinders which is thoroughly tamped, thus forming a firm base for the main foundation of concrete to rest upon. It is important that this sub-foundation be well drained. Drains should be provided at suitable points to carry off any water which may collect under the concrete. An average thickness for the sub-foundation is from four to six inches, although in warm climate, if the ground is firm and well drained, the sub-foundation may be only two or three inches thick, or may be omitted entirely. In the writer's experience, no sub-foundation is required, regardless of soil or climate, if proper drainage is secured.

Details of Construction — A cord stretched between stakes will serve as a guide in excavating. The material to form the sub-grade is spread over the bottom of the trench and thoroughly compacted. Next, stakes are driven along the sides of the walk, spaced four to six feet apart and their tops made even with the surface of the walk when finished. The surface should have a transverse slope of one-fourth inch to one foot for drainage. Two-by-four-inch scantlings are nailed on these strips to serve as a mould for the concrete. By adjusting these scantlings to the exact height of the stakes, they may be used as guides in leveling off the concrete for surface finish. Everything is now ready for the placing of the concrete.

Placing — If a single-course walk is desired the concrete is mixed in the proportion of 1:2:3 and placed in the form to a depth flush with the surface of the moulds. The concrete is tamped slightly until the water shows on the surface, after which a straight-edge is run, with the two-by-fours on the sides serving as guides. The surface is then made smooth by the use of a wooden float or trowel. Do not trowel or use the float too much; it will bring a layer of cement to the surface and weaken the concrete. If a two-course walk is desired, mix the foundation concrete in the proportion of about 1:3:4, and fill the form to within three-fourths to one inch from its upper edge. Tamp lightly until the water begins to appear at the surface. Then use the straight-edge. This can be made from a strip of board about four inches wide. By cutting a notch one inch deep in either end on one side, this straight-edge may be used both for the sub and surface concrete leveling.

It is of utmost importance to lose no time in getting the top dressing upon the concrete base. This dressing should be from three-fourths to one inch thick, as mentioned before. If too much time elapses, the two layers will not unite properly and the result is a weakened concrete. Preferably, the surface coat should be laid within one hour after placing the concrete base. The proportion should be about 1:1½ or 1:2. To secure a smooth even surface, no coarse gravel or crushed rock is used for the surface coat. Where natural bank gravel can be had, enough sand is screened out for this surface coat, while the coarse aggregates are mixed

in with the material to form the base concrete. As stated under "Single-Course Construction," the floating or troweling, though necessary to give a smooth surface, if continued too long brings a thin layer of cement to the surface and probably causes the walk to crack.

The concrete is now divided into sections by cutting entirely through to the bottom with the edge of the trowel or knife. The trowel is guided by using a straight-edge placed at right angles to the sides of the forms, after which the edges are rounded off by the use of a tool called the jointer. A neat appearance may be given to the edges by the use of the so-called edger. The edging and jointing must be done before the concrete settles too firmly. When the concrete is nearly hard, go over the surface with a piece of oakum or stiff brush, removing the marks of the float and giving an even, smooth wearing surface which will not be slippery.

The "Alternate-Slab" Method—The methods described above for making sidewalks are called "continuous construction." Another way to construct is by the "alternate-slab" method. If the walk is to be laid with alternate slabs, as many cross-forms are provided and placed as will be required for a day's work. This will divide the stretch in which the walk is to be laid into rectangular spaces. Two or three inch studdings are generally used for the cross-pieces. In laying the walk every alternate space is filled. The following day the cross-forms are removed and the spaces which have been left are filled. The latter method of construction is seldom used today. The continuous method is to be recommended because of its convenience and rapidity.

Allowing for Expansion—Some masons, in laying continuous walks, recommend the use of cross-pieces at frequent intervals where the slabs are to be cut, to allow for expansion. This extra work is unnecessary where care is used in cutting through the concrete with the trowel, by making spaces wide enough to allow for the slight expansion which will occur. The more frequent the cuts the narrower they may be. By referring to the following table the farmer can determine the exact amount of material needed for the concrete construction which he intends to do:

MATERIALS FOR 100 SQUARE FEET OF CONCRETE

TABLE No. 3

Bags of Cement to 100 Square Feet of Concrete Surface

Thickness	Proportions		
	1:1½:3	1:2:4	1:3:6
3 inches	8½ Bags	6½ Bags	4¾ Bags
4 inches	11 Bags	8¾ Bags	6 Bags
5 inches	14½ Bags	11 Bags	7½ Bags
6 inches	16¾ Bags	13¼ Bags	9½ Bags
8 inches	22¾ Bags	18 Bags	12 Bags
10 inches	28¾ Bags	21½ Bags	15½ Bags
12 inches	34¾ Bags	26½ Bags	18½ Bags

NOTE—The farmer will have little use for any mixture but the 1 : 3 : 6.

Bags of Cement to 100 Square Feet of Mortar Surface

Thickness	Proportions		
	1 : 1	1 : 1½	1 : 2
½ inch	3½ Bags	2¾ Bags	2½ Bags
¾ inch	5 Bags	4 Bags	3½ Bags
1 inch	7 Bags	5½ Bags	4½ Bags
1¼ inches	8¼ Bags	6 Bags	5¾ Bags
1½ inches	10 Bags	8 Bags	6¾ Bags
1¾ inches	12 Bags	9¼ Bags	7¾ Bags
2 inches	14 Bags	11 Bags	9 Bags

Surfaces laid with one Barrel of Cement
No. of Square Feet of Concrete (base) laid with 4 bags (1 bbl.) of Cement

Thickness	Proportions		
	1 : 1½ : 3	1 : 2 : 4	1 : 3 : 6
3 inches	47 Square Feet	60 Square Feet	83 Square Feet
4 inches	36 Square Feet	46 Square Feet	66 Square Feet
5 inches	27 Square Feet	36 Square Feet	52 Square Feet
6 inches	24 Square Feet	30 Square Feet	41 Square Feet
8 inches	17 Square Feet	22 Square Feet	33 Square Feet
10 inches	14 Square Feet	19 Square Feet	26 Square Feet
12 inches	12 Square Feet	15 Square Feet	21 Square Feet

No. of Square Feet of Mortar Surface Laid with 4 Bags (1 bbl.) of Cement

Thickness	Proportions		
	1 : 1	1 : 1½	1 : 2
½ inch	114 Square Feet	146 Square Feet	178 Square Feet
¾ inch	80 Square Feet	100 Square Feet	114 Square Feet
1 inch	57 Square Feet	73 Square Feet	89 Square Feet
1¼ inches	48 Square Feet	60 Square Feet	70 Square Feet
1½ inches	40 Square Feet	50 Square Feet	59 Square Feet
1¾ inches	33 Square Feet	43 Square Feet	52 Square Feet
2 inches	29 Square Feet	36 Square Feet	44 Square Feet

NOTE—Four bags of cement equal 1 barrel.

For proportions 1:1½:2, use for every 33 bags of cement, 1 large double load of sand and 2 of gravel. For proportions 1:2:4, use for every 23 bags of cement, 1 large double load of sand and 2 of gravel. For proportions 1:3:6, use for every 15 bags of cement, 1 large double load of sand and 2 of gravel. One large double load contains 40 cubic feet or 1½ cubic yards.

The completed work must be kept protected from the sun and wind by the use of fine earth, or paper, or other convenient material. If earth or sand is used, it must not be applied until the surface has hardened sufficiently to prevent particles from adhering to the concrete. The cover should be left on two or three days and kept moist during this time, thus insuring a good strong wearing surface.

FLOORS AND OTHER PAVEMENT

The same principles involved in making sidewalks should govern the construction of floors and other pavements. Floors may be regarded as sidewalks placed side by side.

Where the ground never freezes, as in cellars and barns, or where the soil is rather dry and sandy, a drainage foundation of cinders or gravel, as described before, is entirely unnecessary. Moreover, such floors never need expansion cracks. They are made by laying a solid continuous sheet of concrete.

All floors, such as machine-shed and feeding-floors, subject to action

of cold weather, must be provided with contraction joints. These are formed the same as in sidewalks. Instead of using narrow forms as in the case of sidewalk construction, a straight-edge is used long enough for each end to rest on the extreme outside form, thus laying across the entire width at one time. If the floor is for a machine-shed, a driveway or other place where it will receive constant jarring or vibration, it should be built in blocks and reinforced with rods of iron. Such floors must be at least six inches thick and the blocks should not exceed five or six feet in diameter. Unless the ground is quite dry a sub-foundation well packed must be provided if the floor is to be a permanent one. Such floors as cellar and milkhouse floors, or feeding-alleys in barns where the traffic is light, need be only two or three inches thick, provided, of course, that the ground is well packed before the concrete is laid.

Where floors are made three inches or less in thickness, it is recommended that only a single-course concrete be laid, as described under sidewalk construction, while floors of greater thickness are usually double-course, that is, with a one-inch wearing surface on top.

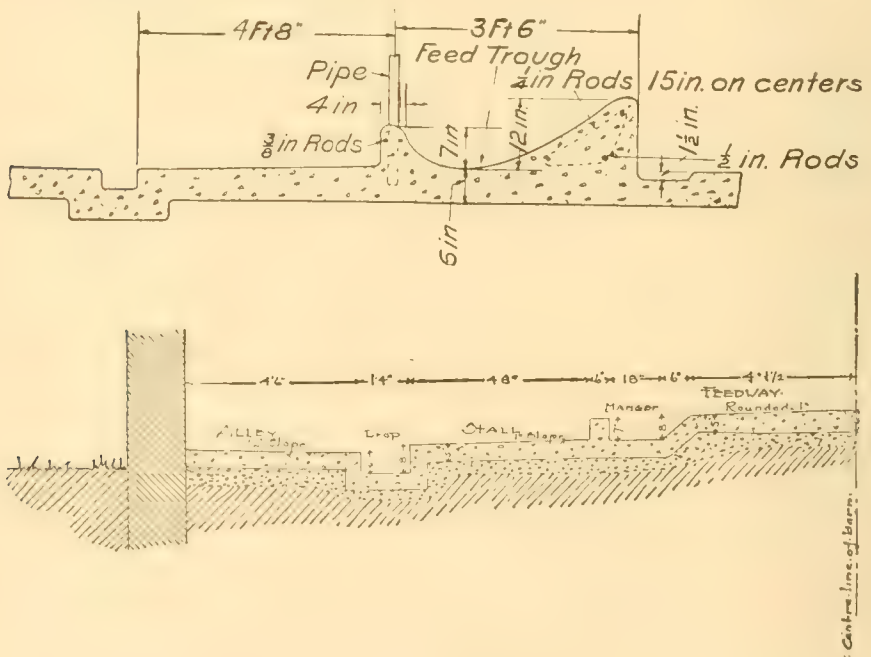

Fig. 18.—Sections of Cow Barn Floors.

No hard and fast rules can be laid down as to the thickness of floors to use for various purposes. It will depend on their use, as well as the strength of the concrete, and the character of the soil on which they are placed. The farmer must use his own judgment. As a general guide, it can be stated that a thickness of from four to six inches is required for driveways and floors subject to vibration from heavy machinery and loads.

While for feeding-alleys, cellar floors, and other places where the vibration, if any, is slight, and where no heavy objects are placed, a thickness of two inches will serve the purpose as well as one of five or six inches.

Preventing Slipperiness — One common objection made to the use of concrete for floors and driveways is that they are slippery when wet; but this fault is in a great measure overcome by dividing the wearing surface into small squares about three or four inches on the side, by means of triangular grooves three-eighths of an inch deep. This gives a very neat appearance, and at the same time furnishes a good foothold for horses. Whether a floor is for a cellar, a milkhouse, a feeding or cleaning-alley, or for a feeding-floor, it should be given a slight slope, toward the center, to one side, or to a corner, with provision at the lowest point for carrying off any water that may accumulate.

CHAPTER V.

THE CONSTRUCTION OF FOUNDATIONS, PIERS AND WALLS

I. FOUNDATIONS—CONCRETE BLOCK AND POURED CONCRETE—FORMS—CONCRETE MIXTURE, II. PIERS. III. TABLE FOR BASEMENT WALL CONSTRUCTION. IV. WALLS—BOLTS IN FOUNDATION—IMPROVING APPEARANCE OF WALL.

Concrete has replaced other materials for foundations and pier construction almost everywhere. Its durability and capacity for bearing heavy loads make it preferable to wood, while its ease of handling makes it more desirable than stone.

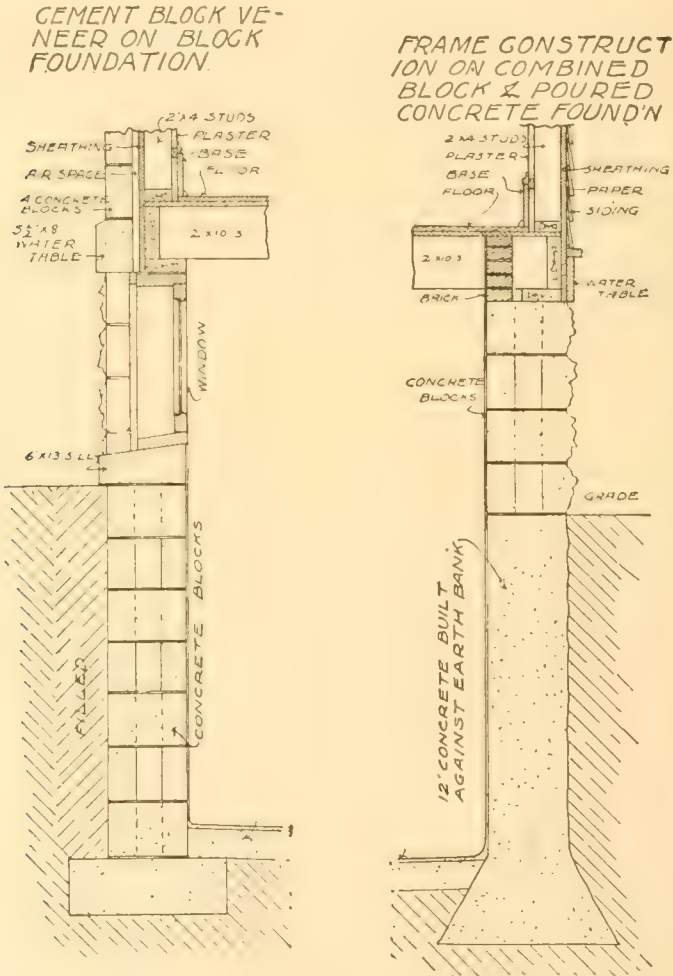

Fig. 19.—Two Standard Types of Concrete Foundations for Houses.

FOUNDATIONS

Concrete Block and Poured Concrete—The first step in building a foundation is to decide its size and class of construction. Then stake out with pegs and string the size of the excavation. If the foundation is to be of poured concrete, the excavation should be of the same dimensions as the foundation; but if of concrete blocks, the excavation must be sufficiently larger than the foundation to allow for proper working space. The two commonest methods of construction are illustrated in Fig. 19.

These are the concrete block and the poured concrete foundation. The superstructure should be attached to the foundation by means of bolts, placed vertically in the concrete before it sets. The length of these varies. They are sunk from three to six inches into the concrete and project just enough to reach through the foundation sill. They are placed every six or eight feet as shown in Fig. 20.



Fig. 20.—Foundation Wall for a Small Shed. Showing Bolts for Attaching the Wooden Sill to the Concrete Foundation.

Unless the soil is quite dry, the foundation should extend well below the frost line to prevent heaving by frost and settling. In digging the trench make the base of the foundation wider than the wall as shown in Fig. 19. This will give a stronger bearing, making the foundation less subject to sagging.

No definite rule can be laid down as to the width of foundation to use. That will depend upon the size of the structure and height of the wall. Sixteen inches is considered wide, while seven inches should be the minimum. For ordinary farm structures, a width of eight or ten inches is usually considered sufficient, provided, of course, that the base is made wider as shown in Fig. 19.

Forms—If the ground is firm, form work below the ground surface will be unnecessary. Forms above ground must be built to the desired height of the foundation. Fig. 21 shows two simple methods of con-

structing such forms, one where the earth or clay serves as a wall on one side, the other showing form needed for a foundation above the ground surface.

Concrete Mixture for Foundation Walls — Concrete for foundation walls should be mixed in the proportion of 1:3:5. That is, one sack Portland cement to three cubic feet clean sand and five cubic feet of gravel or

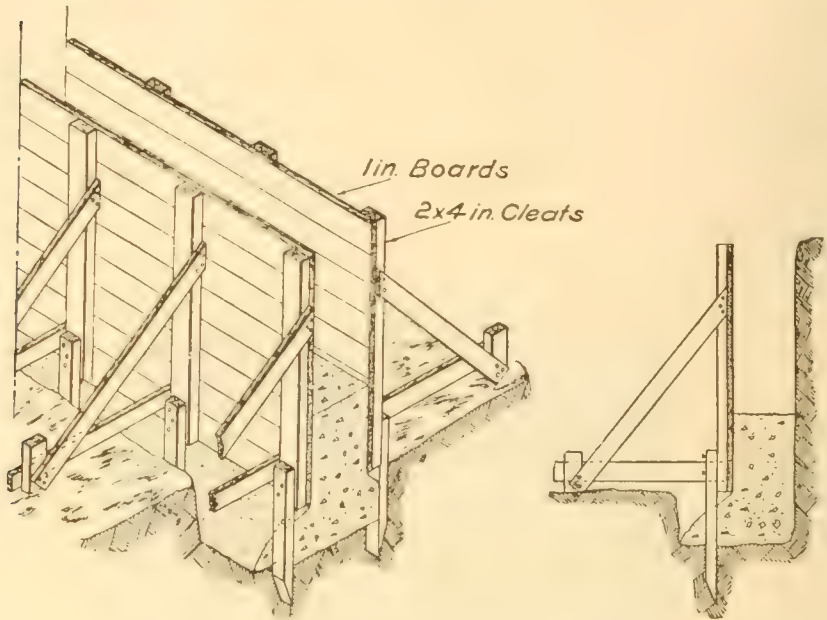

Fig. 21.—Cellar Wall Forms.

stone. If natural bank gravel is used, the farmer must use his own judgment as to the amount. Usually a 1:6 or 1:7 mixture is strong enough for such work. Sufficient water should be added to the mixture to give it a medium consistency so it can easily be made compact in the mould by slight tamping with a spade or a piece of board. If too hard it will not pack well, if too soft, some cement is apt to be washed out.

PIERS

Pier foundations are sometimes used under light and unimportant buildings, generally where it is desired to have a circulation of air under the structure. Pier foundations effect a saving of material over those of continuous structure, but have several disadvantages. The greatest trouble usually is that the pier is not large enough to sustain the load imposed upon it. The average soil will sustain a load of about two tons per square foot, depending on the soil. A pier is many times called upon to support eight or ten tons per square foot. In building piers, ascertain, if possible, what the load will be upon them, and make them about double

the size you think will be required and so thick that they will not crack. Piers are also apt to settle unequally, unless properly constructed, and twist the super-structure out of line or level. Another disadvantage is that snow in winter is apt to drift into the building, which is undesirable for all farm structures. Moreover, rats and other vermin are not shut



Fig. 22.—Concrete Pier Supports for a Large Corn Crib.

out. The use of piers can only be recommended when a farmer of limited means desires to prevent the sills from rotting, by raising the structure above the level of the ground. Gravel, sand or other earth used as a "banking" is effective in keeping out snow. Fig. 22 shows piers under a building.

TABLE No. 4.—THICKNESS OF WALLS AND QUANTITIES OF MATERIALS FOR DIFFERENT HEIGHTS OF BASEMENTS

Proportions: 1 part Portland Cement to 2½ parts of sand, to 5 parts of gravel or stone.

Height of basement	Depth of foundation below ground level	Thickness of wall at bottom	Thickness of wall at top
6 feet	4 feet	6 inches	6 inches
8 feet	6 feet	10 inches	8 inches
10 feet	8 feet	15 inches	10 inches

Cement per 10 ft. length of wall	Sand per 10 ft. length of wall	Gravel or stone per 10 ft. of length of wall
Bags	Cubic Feet	Cubic Feet
6	14½	29
12	29	58
25½	60	120

WALLS

The forms and method of construction for concrete walls are so much like those of foundations that it is not necessary to discuss them in detail. Many suggestions can be secured by looking at the accompanying illustrations or figures. Concrete walls may be built either as a single solid wall or as two walls with an air space between them. Such air spaces render the building less subject to changes in temperature and warrant their extensive use for roothouses, outside cellars and milkhouses. Walls are not so thick as foundations. For most farm structures a thickness of six inches, reinforced with iron, is sufficient. One-fourth-inch rods placed from twelve to eighteen inches apart horizontally and vertically serve as reinforcement. Additional rods are placed in corners and around openings. If an air-chambered or hollow wall is desired, it may be secured in a simple way by the use of planed planks as shown in Fig. 23.

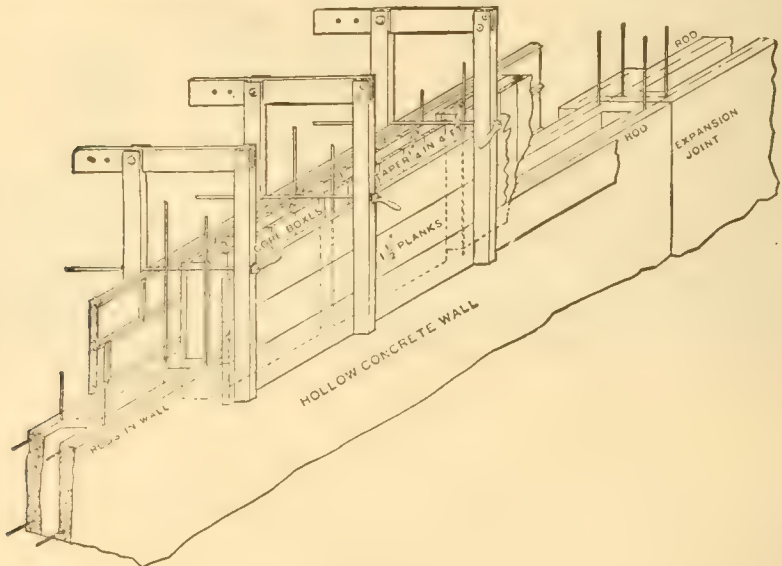

Fig. 23.—Hollow Wall Forms.

Fig. 24 shows an ordinary wooden form and wiring to hold form together.

Bolts in Foundation — See to it that the top surface of the foundation is entirely clean before the concrete is poured into the wall-forms in order to secure a good union or binding. If some time should elapse between constructing the foundation and the wall, bolts or other pieces of iron should be placed in the foundation so as to project into the wall when formed, thus making a strong union between the two. Fresh concrete does not make a good union with concrete that is well set.

Improving Appearance of Wall — On the farm where old scrap lumber is patched up to make forms, the concrete will take the impress of

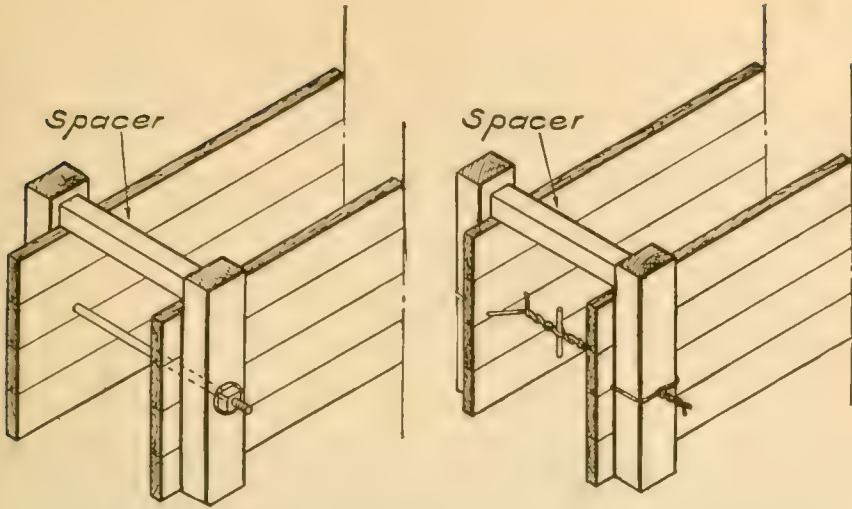

Fig. 24—Section of Forms Showing Method of Holding Sides of Forms.

flaws in the form. If a better appearance is desired, this can be secured by brushing the surface with weak acids and bush hammering, or by applying a coat or two of stucco, which will be discussed later under that heading. A cement grout painted or washed over the surface is not to be recommended. Sooner or later it will begin to scale off and leave the surface more unsightly than ever.

CHAPTER VI. THE CONSTRUCTION OF TANKS, TROUGHS AND CISTERNS

- I. WATERING TANKS OR TROUGHS—CONSTRUCTION OF A CIRCULAR TANK—CONSTRUCTION OF AN OBLONG TANK. II. HOG TROUGHS. III. MILK AND CREAM VAT. IV. MANURE PITS—SHALLOW AND DEEP PITS—THE SINK HOLE—SIDE HILL CONSTRUCTION. V. CISTERNS—THICKNESS OF WALLS.

Concrete is an excellent material for the construction of tanks and troughs. They are, if properly built, permanent, and cheap in first cost. They will not rust, fall to pieces, leak or burst, and are in every way more satisfactory and serviceable than those made of any other material.



Concrete Feeding Floor and Watering Trough at East Norwich, L. I.

WATERING TANKS OR TROUGHS

For construction we shall call watering tanks of all sort, troughs. They are usually either oblong or circular in shape. A circular tank in combination with a feeding-floor is illustrated above.

Circular troughs are used principally in open fields to allow approach on all sides. The oblong are more convenient in stables and barns as they require less space for their capacity. If the troughs are of large

size, they must be provided with proper drainage and a substantial foundation in order to prevent bursting from frost upheaval.

Construction of a Circular Tank — For a circular tank of large size the simplest form can be made from strips of sheet iron braced with boards sawed to conform to the desired curve of the tank. If a tank of small dimensions is desired, a form can be made by using any con-

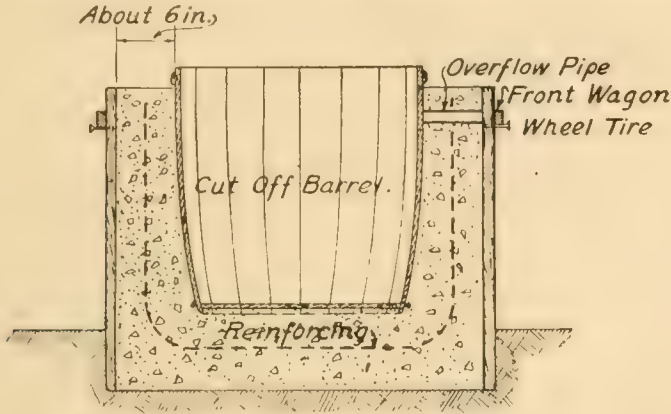

Fig. 25.—Design of Forms for Circular Trough.

venient boards placed vertically for the outside, and suspending inside an ordinary rain barrel coated with soap or oil, as shown in Fig. 25. A couple of old buggy or wagon tires can be used to good advantage for holding the outside form.

The Construction of an Oblong Tank — The form for a rectangular



Fig. 26.—Oblong Tank.

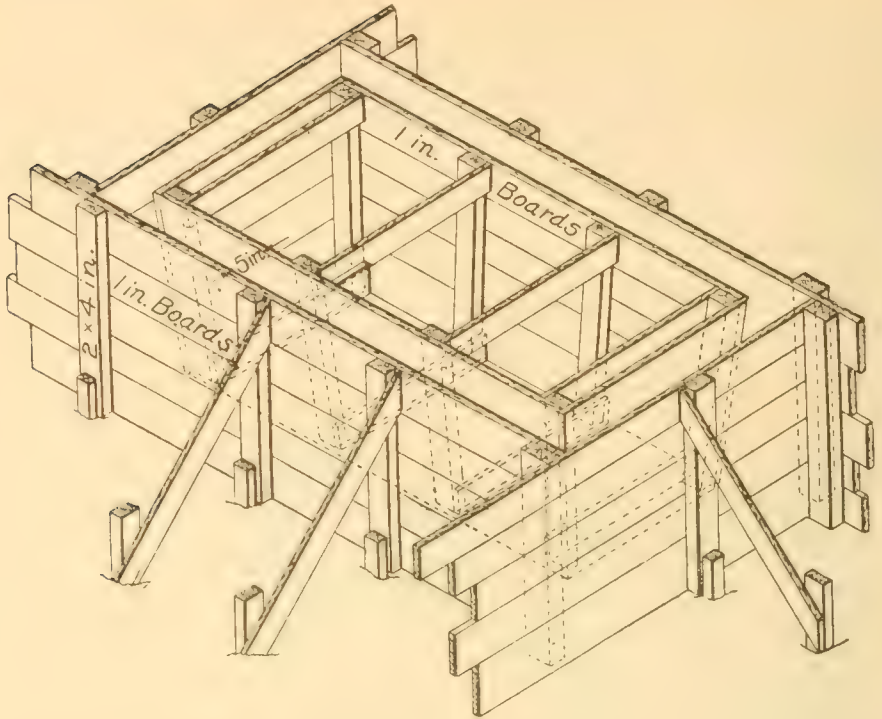

Fig. 27.—Design of Forms for Rectangular Trough.

tank as shown in Fig. 27 is economical in that the lumber for the outside form need not be cut and can therefore be used again. It will be seen from the diagram that the forms for oblong or rectangular tanks consist of two boxes without top or bottom, one suspended inside of the other. The outside box rests on the ground, while the inside hangs from four to six inches above the ground surface. In constructing the forms, whether circular or rectangular, make the inside of the forms slant out at the top to allow for the expansion of freezing, thus eliminating the possibility of bursting. Another advantage of having the inside box widen towards the top is that the form is easily removed. It must be borne in mind that this form must be taken out before the concrete sets very hard; and in order to do this and not injure the concrete, it must be so constructed as to free itself entirely from the concrete just as soon as it starts to move. Many tanks have been ruined by failure to get out the inside form on time and easily. Troughs are made with about six-inch walls of 1:2:4 wet concrete. They are sometimes reinforced, for which purpose wire nettings, twisted wire or steel rods are used. Openings for inlet and drain pipes must be provided before the concrete is laid.

HOG TROUGHS

Concrete makes clean, sanitary and durable hog troughs. In Fig. 28

are shown a couple of simple and easily built troughs that can be made by any farmer.

The form consists of a bottomless box placed on any level floor or piece of ground having the dimensions of the desired exterior of the trough. On the inside is placed an inverted oblong box having the exterior dimensions of the desired core of the trough. A 1:2:1 concrete is placed in the form and is leveled off at the top by the use of a straight strip of board or a straight edge. Reinforcement, if desired, is placed as shown in the diagram.

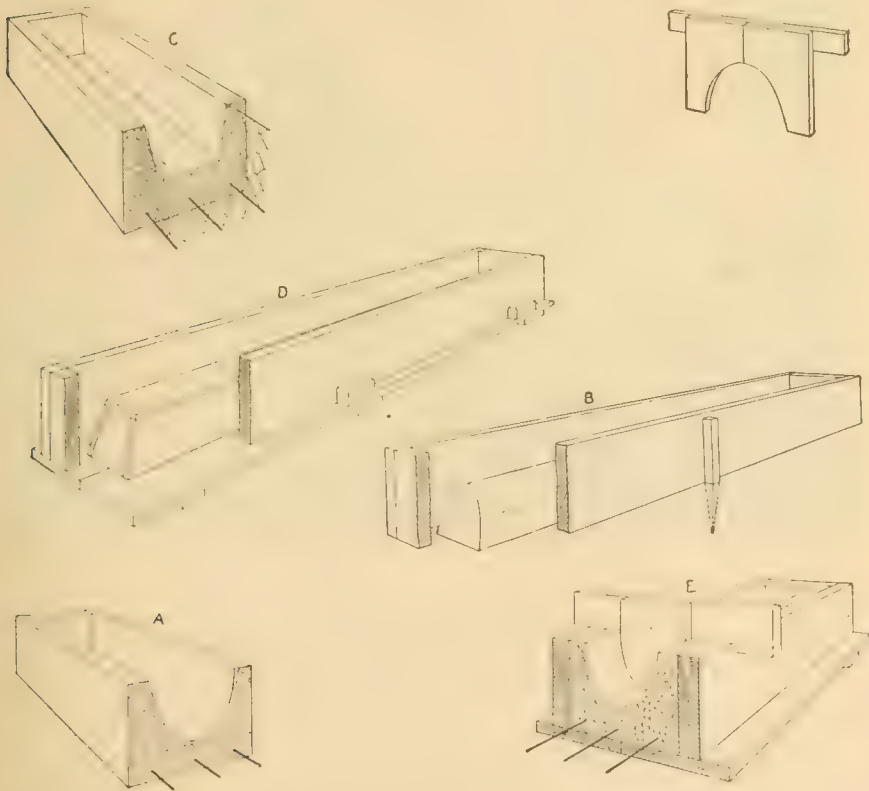

Fig. 28.—Concrete Hog Troughs.

A CONCRETE MILK AND CREAM VAT

There are few things on a farm where cows are kept that are more needed and more useful than a well-constructed milk and cream vat. The construction of such a vat is as follows:

Dig a pit to a depth of 1 foot and 6 inches and place wooden forms in such a way as to provide for tank walls 6 inches thick and 1 foot 8 inches in height. This will bring the walls only eight inches above ground level, making it easy to lift the cans in and out. Use a 1:2:1 mixture and build

walls and floor at the same time. Inlet and outlet pipes must be in position before the concrete is placed.

In choosing the location of the cream vat in the pumphouse, the farmer should have convenience in view. If the watering trough can be placed at a lower point than the milk vat, then the latter should be placed close to the pump. In pumping the water for the stock, the water can be pumped to enter one end of the vat, pass between the cans, thus cooling



Fig. 29.—A Milk and Cream Vat.

them, flow out at the other end of the tank, and be carried to the watering tank by means of pipes. In the writer's experience, where the above method was used in cooling, a temperature of the milk only four or five degrees above that of the water in the well, was obtained in a comparatively short time. The construction of a milk vat is shown in Fig. 30. The completed vat appears in Fig. 29.

MANURE PITS

The value of manure as a fertilizer is too well known to need mentioning; also the fact that the greater part of its value is wasted by being stored in sheds or piled in the open. When piled in the open, the manure deteriorates by being leached by rains, and when stored in sheds most of its manurial value is lost by "firing."

The logical remedy for both of these features is the construction of a concrete manure pit. One load of manure stored in a pit is worth two loads of manure as usually stored. The chief value of a manure

pit lies in the fact that the liquid manure—the most valuable portion—is preserved. It is obvious then, that where manure is not hauled directly to the field, a manure pit will pay for itself in a comparatively short time.

Shallow and Deep Pits—There are two forms of pit in common use. They are the shallow and the deep. Shallow pits will do where only a small amount of stock is kept, or where the manure is frequently hauled to the field. The floor of such a pit should be from 2 to 6 inches

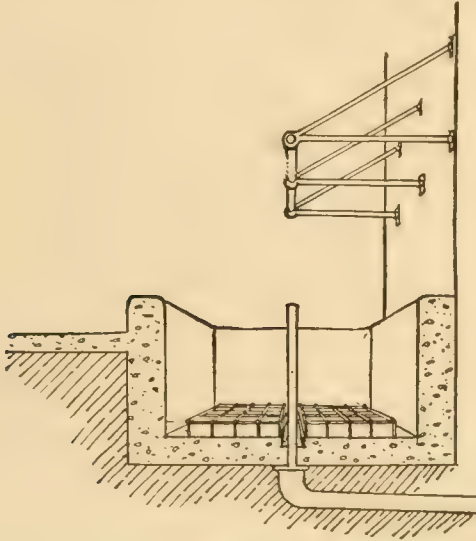

Fig. 30

and the walls about 10 inches thick. The clear dimensions of the pit whose lateral section is shown in Fig. 31 are: depth 3 feet, width 6 feet, length, 12 feet.

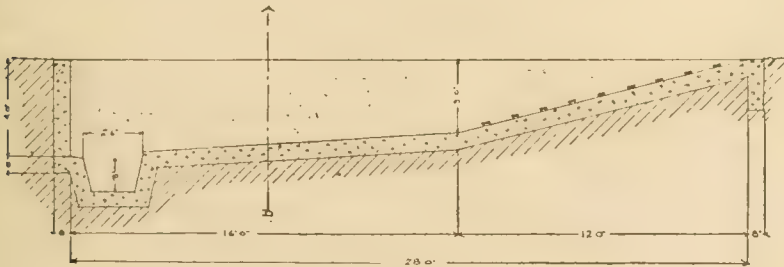

Fig. 31

By keeping the sides vertical while digging the pit, only inside forms are needed for laying the concrete. The inside form is shown in Fig 32.

The Sink Hole—In order to form a sink hole from which the liquid

manure can be pumped, in one corner at the deep end of the pit, dig a hole about 18 inches deep by 2 feet 6 inches in diameter. To protect the concrete floor, at the upper end of the driveway, excavate a trench

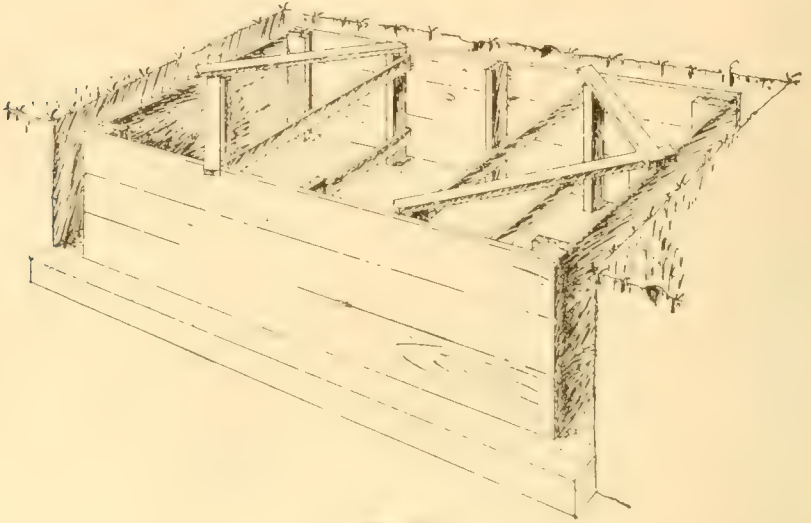

Fig. 32

6 inches wide and 1 foot 6 inches deep for a concrete foundation. (See Fig. 33). The deep manure pit is built exactly like the shallow one. The incline or slope must necessarily be longer because of the greater



Fig. 33.—Building a Manure Pit in the Side of a Hill.

depth of the pit. Whatever depth of pit is used the run must not be steeper than 1 foot rise to 4 feet of surface run. In other words, a pit 4 feet deep will require a driveway or run of 16 feet.

Side Hill Construction — On farms where the pit can be conveniently constructed mostly above ground, or in a side hill, where one side at least extends above the ground, much time and money can be saved by leaving out the driveway leading into the pit. The spreader can be loaded from one or more sides of the pit. In such a case the pit must be made so narrow that the manure can be conveniently loaded into the spreader. If loaded from one side, the pit should not be more than 6 or 8 feet across, while if accessible to the spreader on both sides, the pit may

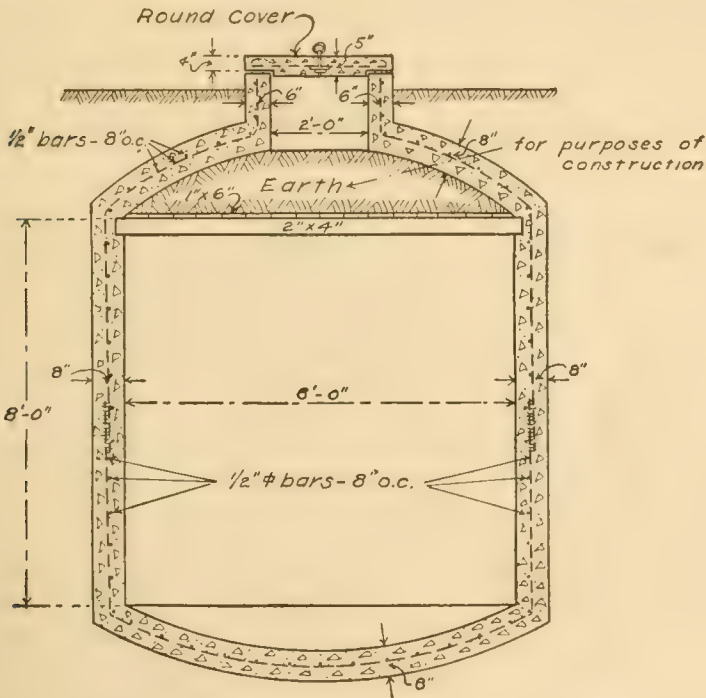

Fig. 34.—Diagram Showing Method of Placing Concrete Arch Top on Cistern.

have the usual width of 12 or 14 feet. Mix the concrete in the proportion of 1:2:4. That is, one bag Portland cement, two cubic feet sand and four cubic feet crushed rock or coarse gravel. If natural bank sand and gravel is used, it may be mixed in the proportion of about 1:5.

The protection of concrete after placing, as previously discussed, applies to the manure pit.

CISTERNS

Because of their water-tight character, durability and cleanliness, concrete cisterns are fast replacing the old-fashioned rain barrel.

Cisterns are, in the northern states, almost without exception, built underground. Surface cisterns are unsatisfactory because they are apt to freeze during cold weather and because they are difficult to construct.

There are two types, the rectangular and the round. Although the latter is a little harder to construct because the forms are harder to make, it is much to be preferred because of its greater durability.

In digging the excavation, allow about eighteen inches more than the desired diameter of the cistern. Dig to a depth of from ten to sixteen feet. After excavating, lower the forms into the pit and fill with concrete in the proportion of 1:2:4.

Make the concrete of such a consistency that it will "run" in order to insure a compact wall. To make sure that no pockets are formed, a piece of scantling or other piece of board for tamping can be used to good advantage.

The Thickness of the Walls—This will depend on the character of the soil, the location of the cistern, and its size. Sandy and gravelly soils are best for cistern construction. In a loose porous soil the wall must be thicker than if the soil is of a hard clayey character. If the cistern is built under the house, which should be done wherever possible, the frost has less action, and the walls need not be very thick. The narrower the cistern the thinner the walls need be, because of their greater power of bracing and resisting external influences such as frost. The top of the cistern may be finished off in the form of an arch as shown in Fig. 34, with a round cover or manhole in the center; or the cover may be flat with the manhole placed at any point.

As previously stated, the firmer and drier the soil, the less thickness of wall is required. On the writer's farm an oblong and rounded excavation was made under a corner room of the house. The subsoil is a rather hard compact clay. In digging, the walls were made as smooth as possible and the bottom was rounded off in the form of a kettle. Two coats 1:1½ concrete, each about five-eighths or three-fourths of an inch thick, were plastered directly on the clay wall. The inside was washed with a coat of cement wash made by adding water to pure Portland cement. This cistern is fully as strong and is just as serviceable as when built ten years ago.

SEPTIC TANKS

Sewage Dangers—The proper method for the disposal of house sewage is an important question on the farm. Cesspools, pits dug in the ground, are great disease spreaders. The liquid from them seeps through the ground, carrying germs from the pool to the well, making it unfit for use. Dangerous and infectious diseases are often started and spread in this way.

Through the use of an inexpensive septic tank all the conveniences of the toilet and bath may be installed in the house and the danger from

sewage removed. A septic tank is nothing but an underground water-tight cistern through which the sewage passes slowly and evenly. Located underground, it is warm and dark, and conditions are ideal for the development of the bacteria which eat up the sewage and render it harmless. To prevent the bacteria (which live in the frothy dudge) from being disturbed, cross walls or baffle plates or boards are placed

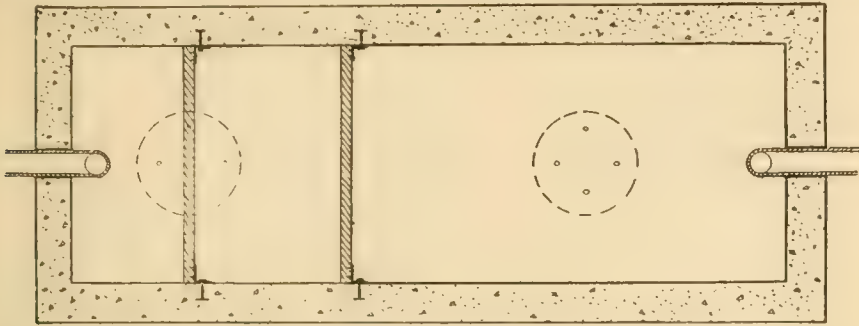

Fig. 35.—Top View of Septic Tank.

crosswise in the tank to break up the current of the inflowing sewage.

This sewage, which is purified by the bacteria before passing out, becomes merely pure water which may be removed by means of a drain tile.

Construction of Tank—Locate the septic tank where it can be placed with the side walls entirely underground and out of danger of floor waters.

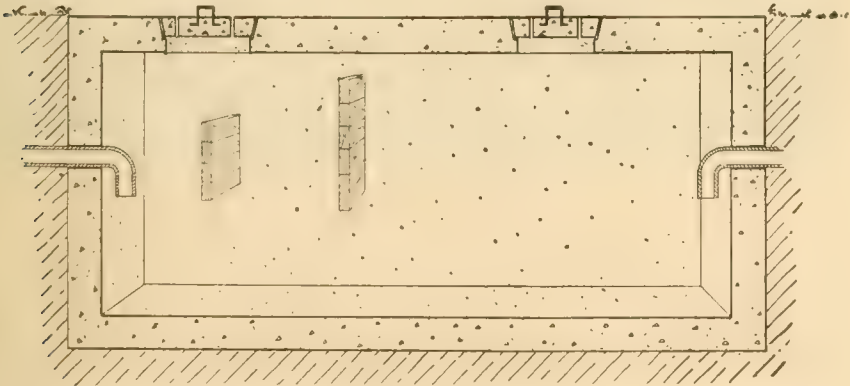

Fig. 36.—Lateral View of Septic Tank.

For a family of eight or ten, plan a tank with 6-inch walls, 3 feet wide, 2 feet deep, and 5 feet long, inside dimensions. The forms can be made exactly like those of watering troughs as previously described.

Figures 35 and 36 show top and lateral sections of the tank with location of manholes at the top, the inlet and outlet pipes in each end,

and the location of the baffle boards. Before filling the forms, set the 6-inch inlet and outlet drains at the same height, 2 feet 6 inches below the ground level. To aid further in breaking up the sewage current and keeping out much air, use elbow bends as shown in Fig. 36, so that the sewage in the tank will cover the mouths of the tile. In the side forms, at distances of two and four feet from the inlet wall, set $\frac{3}{4}$ -inch bolts to which the baffle boards are later attached. These boards reach entirely across the tank, project above the sewage, and extend to within one foot of the bottom. The cover in which are placed two manholes as shown in Fig. 37, should preferably be built of concrete, the thickness of which will vary. Usually a five or six-inch reinforced concrete is sufficient. While



Fig. 37.—Completed Septic Tank.

making the manhole, inset three or four strips one inch square. These are pulled out when the concrete is set, leaving small openings for ventilation.

Where the winters are severe the top of the septic tank should not come to the surface of the ground as it is likely to freeze during severe weather. It should be about three feet below the surface of the ground and the concrete wall providing for the manholes should be extended up to the surface of the ground, this will prevent the septic tank from freezing in severe weather. There is not enough sewage from the ordinary house to keep the temperature in the septic tank high enough to prevent freezing during cold weather. When once it freezes serious trouble begins.



Fig. 38.—Concrete Cellar Way.

CHAPTER VII.

THE CONSTRUCTION OF STEPS AND CELLARWAYS

I. CASTING STEPS IN SEPARATE MOULDS. II. MONOLITHIC CONSTRUCTION. III. WALL AND STAIR FORMS BUILT TOGETHER.

Casting Steps in Separate Moulds— Because of its durability, low cost, ease of construction and good appearance, concrete has proved itself the logical material to use for steps and stairs. There are two types of construction. Those made in one piece (monolithic) and those cast in separate moulds and put into place.

The sketch at the left of Fig. 39 shows the form for a single step, the one at the right, the position of the steps after placed, when steps are cast separately. In the diagram, a 1-inch surface is shown. If the farmer desires a neat appearance as for front porch steps, he may go to the extra trouble and expense of finishing them off in this manner; but where looks are of minor importance, as in cellarways, steps will serve the purpose just as well without the finishing coat.

Monolithic Construction— Steps of the monolithic type are to be preferred because they are less liable to displacement from the action of frost. There are different methods of constructing forms, and the farmer must use his own ingenuity to meet the requirements of his special need. If, for instance, he wishes to build a cellarway and steps, he may either build the wall and steps separately, building the wall first in the manner discussed under the heading of concrete walls, and putting the steps in after

the walls have hardened and the form has been removed, or he may build the two forms in one.

By looking at Fig. 40, one will understand how to dig out the earth before placing the forms. In placing the forms, it is only necessary to place boards where the "risers" come, in order to prevent the concrete

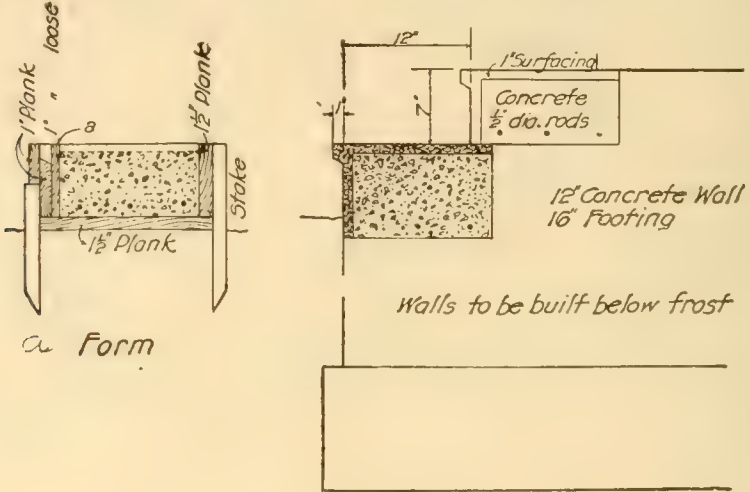

Fig. 39.—Form for a Single Step and Steps in Place.

from running down upon the step below. The run of the steps needs no form. Their surface is finished off with a wooden float or trowel.

One simple method of constructing the mould is as follows: Saw out two boards just as you would a "horse" for steps. Nail boards where the "risers" come, holding the two notched boards or "horse" the proper dis-

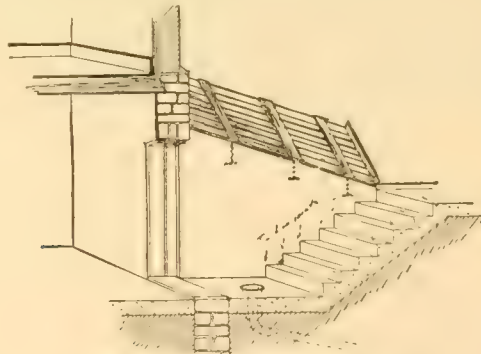

Fig. 40.—Diagram of Cellar Way.

tance apart, in other words, the desired width of the stairway. Then place this mock stairway upside down in the incline where the stairway is to be. It thus serves as a mould.

Wall and Stair Forms Built Together - Another method of construction is to build the wall and stair form in one. This is done as follows:

Dig out the incline as before. Start building the form at the bottom. Assume that we are building a cellarway having two or more steps, that the run of the steps is 1 foot, with a rise of 8 inches and a width of 3 feet 6 inches, and that a 3-foot run or bottom landing of concrete 5 inches thick is also desired. Then proceed as follows: Saw off two pieces of 8-inch boards, 3 feet long. Saw off another piece of board 3 feet 6 inches long, and nail them together, making a three-sided box without top or bottom. Place this form 5 inches from the bottom of the trench to allow for a landing 5 inches thick. Place it with the open end toward the cellar door, fastening the ends to the wall on either side of the door. Brace slightly to hold the form in place. Then saw off two more pieces of board, 1 foot longer than the first two (4 feet), and another cross-piece 3 feet 6 inches long, nail together as before and place on top of the first form. Continue this until the desired number of steps are provided. The advantage of such a form is, that all the concrete for the bottom landing, the walls

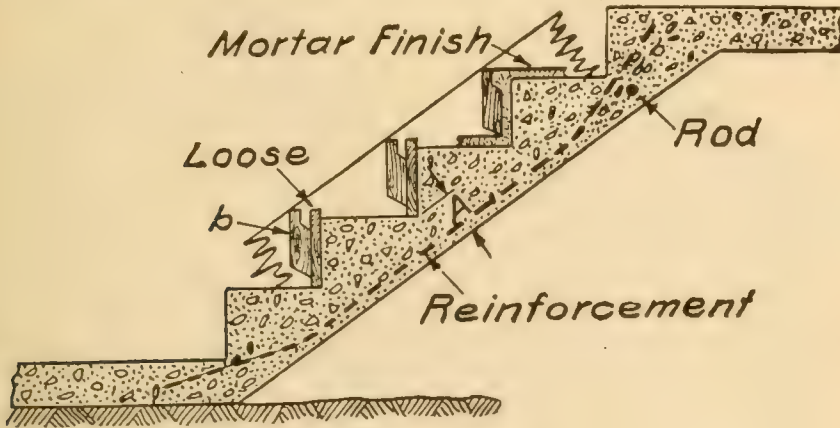

Fig. 41.—Concrete Steps.

and the steps can be made and placed at one time. Use a 1:2:4 or a 1:2½:5 concrete for steps. Whatever method is used, the desired width and run of stairs can be secured by using boards of different widths and lengths. If, for instance, a rise of only 6 inches is desired, then 6-inch lumber can be used. Steps usually have runs from 9 to 12 inches with a rise of from 6 to 8 inches. By modifying the above methods of construction, the farmer can make various kinds of steps and stairs to suit his needs and desires.

CHAPTER VIII.

FENCE POSTS AND STUCCO WORK

- I. CONCRETE FENCE POSTS. II. TABLE FOR MATERIALS IN MAKING SIX-POST BATCH.
 III. STUCCO—USES FOR—APPLICATION—COLORING.

The most important considerations in securing fence posts are cost, appearance and durability.

While concrete posts are higher in first cost, their appearance and permanency warrant their ever increasing use on the farm. Concrete posts properly constructed will last forever. This, together with their uniformity of shape, color and size, give added value to the property

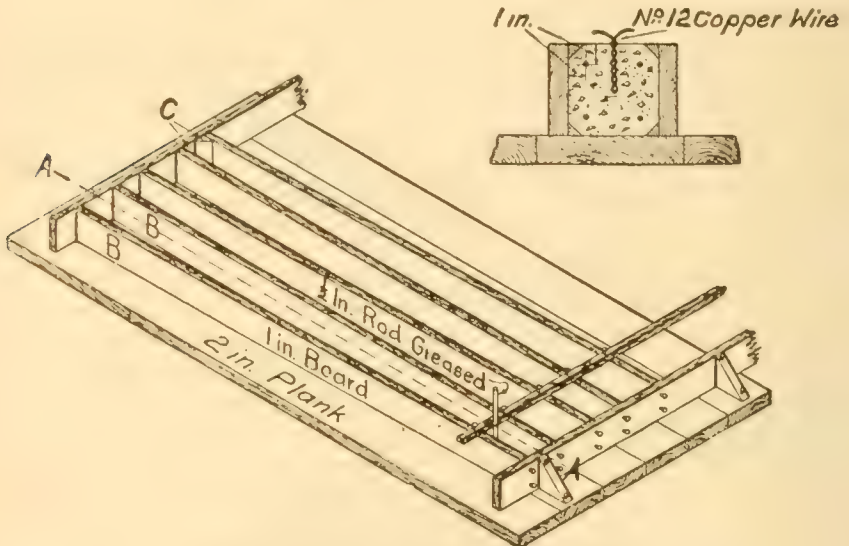

Fig. 42.—Design of Forms for Fence Posts.

by improving its appearance. A durable and well constructed fence gives the passerby a favorable impression, and is a sign of thrift and prosperity. Concrete posts are especially recommended for fences permanently placed. There are several kinds of moulds used. The one shown in Fig. 42 is probably as good as any.

The moulds can be placed on any level floor. Before pouring the cement mortar into the moulds, they should be coated with soap, oil or other greasy material, in order to prevent the concrete from sticking or adhering to the wood.

The reinforcing should be on the side of the post where the stress will be, and should be placed as near the corners as possible without

being exposed. Corrugated rods or woven fence wires are the most usual materials to use for reinforcement.

The proportion of concrete should never be weaker than 1:2:4, and must be carefully mixed, as described under "How to Mix Concrete by Hand," in Chapter II.

Moisten the mixture as much as possible, the strongest post being made from a concrete which, when poured into the moulds, is a thick paste.

The greatest difficulty with concrete posts seems to be the securing of the wires permanently. Several methods are used. The sketch shows a copper wire bedded in the concrete as it is being constructed; this is to attach the wire fencing to, as it is being stretched. Another method is to place spikes in the mould or pieces of iron about $\frac{1}{4}$ inch in diameter that will leave holes clear through the post. In these holes loops of wire can be placed over the fence wire and twisted tight on the back of the post to hold them. Another method is to insert a heavier staple than the one shown of copper wire, say one $\frac{3}{16}$ inch in diameter, making a staple projecting out of the post about one inch. To this the fencing can be fastened with small bits of wire. Other methods will probably suggest themselves to the farmer.

Mixing a Six-Post Batch—The following table prepared by the United States Department of Agriculture gives approximate quantities for a batch of concrete sufficiently large to make six posts 7 feet long and of the sizes named in the table. The quantities may be increased in like proportion and any desired number of posts may be made. The first of the two lines of figures given for each of the three grades, heavy, medium and light, indicates proportions to be used when the sand is screened from the gravel. The second line gives the proportions when "bank-run" gravel is used; that is, gravel dug directly from a bank without screening the sand. In this case one part of cement to four parts of the mixture of sand and gravel should be used.

TABLE No. 5. QUANTITIES OF MATERIAL AND RESULTING AMOUNT OF CONCRETE FOR A SIX-POST BATCH
Triangular Posts—Length, 7 Feet

Size of Post	Proportions of materials by parts, measured in volume.			Materials in cubic feet, measured loose.			Concrete tamped, cubic feet	Water for mixing, gallons
	Cement	Sand	Gravel or rock	Cement	Sand	Stone or gravel		
Heavy	1	2	4	1.4	2.8	5.6	6.2	11
	1	4	4	1.5	6.0	6.0	6.2	11
Medium	1	2	4	1.3	2.6	5.2	5.5	10
	1	4	4	1.4	5.6	5.6	5.5	10
Light	1	2	4	1.1	2.2	4.4	4.8	9
	1	4	4	1.2	4.8	4.8	4.8	9

Rectangular Posts—Length, 7 Feet

Straight, 5 by 5	1	2	4	1.7	3.4	6.8	7.3	13
	1	4	4	1.8	7.2	7.2	7.3	13
Taper on two sides, 4½ by 6,	1	2	4	1.6	3.2	6.4	6.9	12
	1	4	4	1.7	6.8	6.8	6.9	12
Full taper, 5 by 6, 4 by 3	1	2	4	1.5	3.0	6.0	6.7	12
	1	4	4	1.6	6.4	6.4	6.7	12

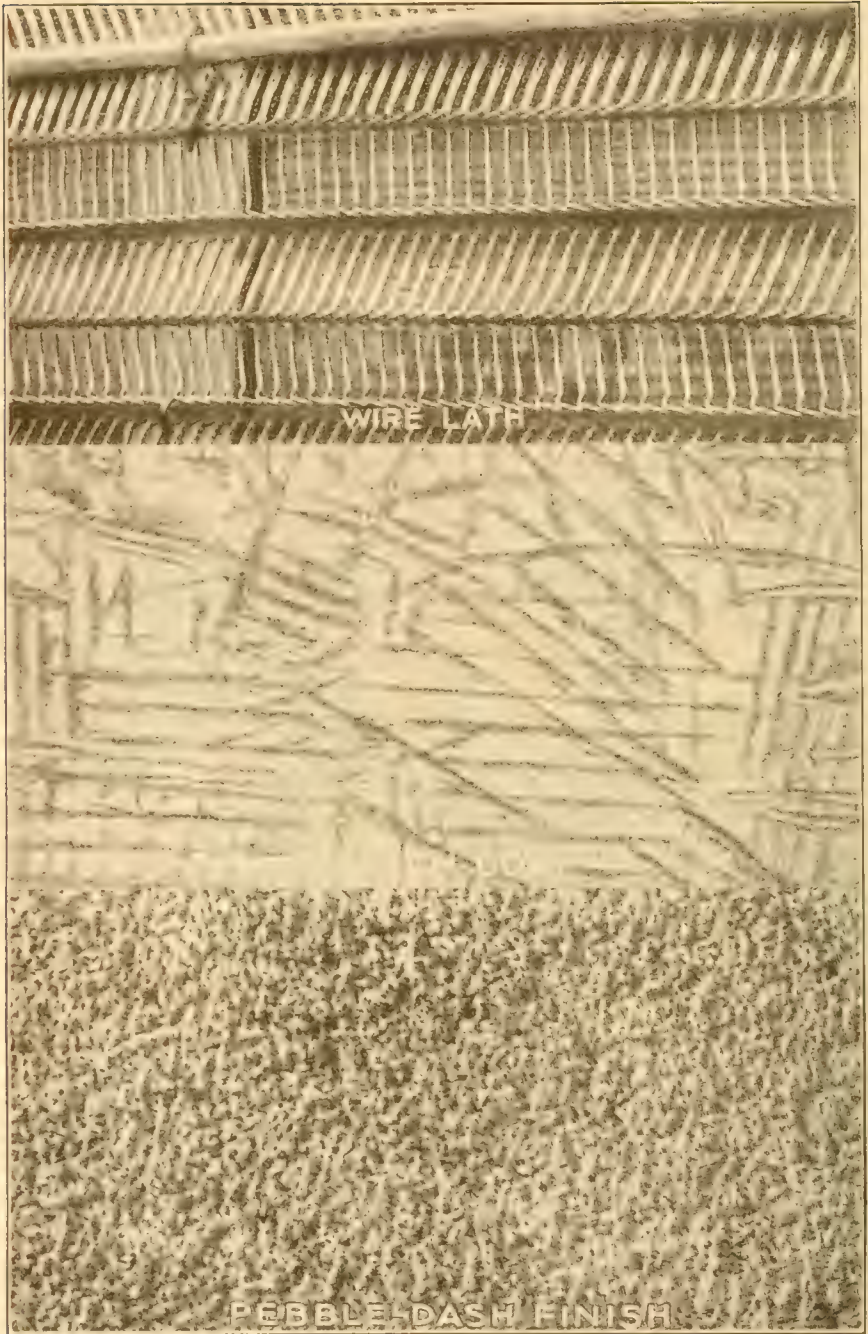

Fig. 43.—Showing the three coats used in stucco work with the pebble-dash finish. The first covering of wire lath is shown at the top, the scratch coat laid on next is shown at the center, and the pebble-dash finish coat at the bottom.

For posts, a convenient measuring unit is a box 12x14 $\frac{3}{8}$ inches and 10 inches deep, measured on the inside, with an open bottom. This box, filled to the top with the loose material and smoothed level, contains practically one cubic foot. The inches in height may be marked with brass tacks. Then, since each inch in height represents one-tenth of a cubic foot, the measurements are easy.

The cost of concrete posts is given at from twenty-eight to thirty-two cents a piece. However, this cost on the farm may be reduced by building them when other work is slack.

STUCCO

Stucco work is cement plastering. It is durable, artistic and impervious to weather. For veneering new buildings, or protecting old structures, and wherever the cost of solid concrete is prohibitive, Portland cement stucco cannot be equaled.

Stucco work may be used to cover wood, brick, stone or any other building material, provided special precautions are taken in preparing the surface properly, so that it will adhere and not crack or scale off. The work should be done by an experienced plasterer.

As a rule two coats are used; the first 5 parts Portland cement, 12 parts clean, coarse sand, and 3 parts slaked lime, putty and small quantity of hair; the second a finishing coat composed of 1 part Portland cement, 2 or 3 parts clean coarse sand, and no lime. Should one coat be desired, the finishing coat is used.

Application—To apply stucco to brick, or stone, or concrete, clean the surface of the wall thoroughly, using plenty of clean water so as to soak the wall. If the surface is smooth concrete, roughen it by picking it with a stone ax. Plaster with a coat of the mortar and finish the surface with a wood float. If a rough surface is desired then cover the float with a piece of burlap. Protect the stucco work from the sun and keep it thoroughly wet for three or four days; the longer it is kept wet the better.

In using stucco on a frame structure, first cover the surface with two thicknesses of roofing or other paper made for that purpose. Next put on furring strips, about one foot apart and on these fasten wire lathing as shown in Fig. 43. Apply the scratch coat one-half inch thick and press it partly rough through the openings in the lath, if necessary roughening the surface with a stick or trowel. A roughened surface is shown in Fig. 43. Allow this to set well and apply the finishing coat one-half inch thick. This coat may be put on and smoothed with a wooden float; or it may be thrown on with a large stiff brush, if a spatter-dash or rough finish, as shown in the lower end of Fig. 43, is desired. For a pebble-dash finish, one part Portland cement is used with two parts coarse sand, not exceeding one-fourth inch in diameter.

If other than a natural color is desired, coloring is added according to the table under "Coloring" in Chapter II.

While concrete may be used for a number of purposes on the farm that have not been mentioned in these chapters, we feel that enough has been said under the various headings to enable the farmer, by a little study and intelligent thinking, to make any other structure of concrete desired.

BOOK VI

FARM DRAINAGE, DRY FARMING AND IRRIGATION

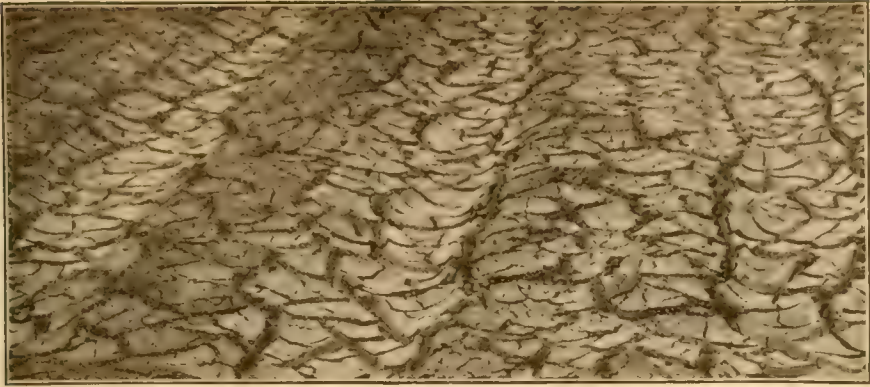

PART I—FARM DRAINAGE
CHAPTER I.
PLANNING A DRAINAGE SYSTEM

I. INTRODUCTION. II. BENEFITS OF DRAINAGE—EXCESSIVE WATER IS INJURIOUS—DRAINAGE INCREASES LAND VALUES. III. PLANNING DRAINAGE SYSTEMS—TO DETERMINE THE GRADE—FARMERS CAN DO THEIR OWN SURVEYING—METHOD OF SURVEY.

Many farms are in need of a good system of drainage, and, where the work is well done, the system will prove to be most profitable.

Drainage is, as C. G. Elliot, drainage expert of the United States Department of Agriculture, says, "A necessary accompaniment of scientific agriculture;" and, "those who have gone into the subject of improvement by drainage have discovered greater advantages and more surprising benefits than were formerly thought possible." During recent years, drainage in many states has been given more attention and financial support by the state and national legislatures than ever before. From an economic point of view it is altogether proper that they should do so, because most of the tillable land in the Northwest is now taken up; the land is rapidly increasing in value, and new homes must be provided for the ever increasing population.

There is in some of the northwestern states enough unreclaimed swamp land, if properly drained, to provide close to 100,000 homes with an average of 100 acres per farm. Minnesota alone has about 5,500,000 acres of unreclaimed swamp land; Michigan and Wisconsin follow with about 2,500,000 acres each; Iowa, Indiana and Ohio have in the neighborhood of 925,000, 600,000, and 130,000 acres respectively.

The states and the government provide laws under which drainage plans can be organized for large portions of this land, the cost of construction being apportioned to settlers along the course of the ditches according to benefits derived. Large ditches capable of carrying an immense amount of water and draining thousands of acres of swampy unreclaimed land are being constructed.

While such ditches are effective in draining a region in a general way, yet the individual farmer must construct small branches and sub-branches leading into the large ditch if thorough drainage is to be effected.

These chapters will be limited to practicable methods of draining land, and to methods of drainage needed under ordinary farm conditions where creeks, rivers, and ravines serve as outlets for surface water. We shall state the advantage of such drainage, give methods for constructing the best drainage systems possible, and, finally give some of the results obtained where such systems have been put in practice.

BENEFITS OF DRAINAGE

That excessive water in the soil is detrimental, is well known to every farmer. The reason, we believe, that farmers have not provided a means for removing excessive water on their farms, is not that they believe drainage a losing investment, but because they generally have not available funds and because the average farmer is too busy during the season when ditching ought to be done. Usually, when the horses are idle just after spring work and ditching could be done most economically, the crops on fields in need of drainage are well started, and the farmers hesitate to destroy part of them. This is especially true where the sloughs or "pot holes" to be drained are situated in the fields at a considerable distance from the road ditch or other outlet.

Excessive Water Is Injurious — To appreciate the value of drainage, we must understand in what ways excessive water is detrimental. The following from a Wisconsin Bulletin covers the point thoroughly: (1) Excessive water makes land so soft that it cannot be cultivated. When these areas are long and narrow in form, they cut the upland into irregular pieces that cannot be cultivated conveniently. (2) It delays cultivation, particularly in the spring. (3) It makes soil cold; (a) because in the spring more than half of the heat that the soil receives is used to warm this unnecessary water; (b) because the evaporation of water consumes heat that the soil could otherwise retain; and (c) because its presence in the soil prevents the entrance and downward movement of rain water, which in the spring is usually warmer than the soil. (4) It crowds the air from between the soil grains, thus hindering the necessary changes of organic matter in the soil. (5) It prevents the deep root development of plants.

Drainage Increases Land Values — The prosperity of a community and the value of land is measured to a large extent by the appearance of the fields. Other things being equal, the passer-by, or prospective buyer, is so favorably impressed with a well-drained piece of land as compared with an undrained piece of land, that he is willing to pay enough more for the drained land to cover previous drainage expenditures.

When a person, whether a prospective buyer or a passer-by, sees a farm where the sloughs are well drained, and the fields laid out squarely and regularly, he will usually find also neat, attractive and well arranged buildings, the garden, lawn and shade trees about the place well cared for, the weeds kept in check, and the fences neat, straight and well cared for — every indication of thrift and prosperity. Passing on he may come to another farm of equal fertility where numerous sloughs dot the fields, water-logging the adjacent land, and where the fields are necessarily irregular. There he will almost invariably find unsightly farm buildings, the yard and field full of weeds, and the fences crooked and ill-kept — all evidence of indifference and unprogressiveness.

Considered only from a speculation standpoint, good drainage is generally a paying investment. The difference in appearance of the two farms just mentioned, would certainly, in a sale, bring a margin in favor of the drained farm sufficient to pay for prior drainage expenses. Besides this, the well drained farm brings an annual increased revenue due to its increased productiveness.

LAYING OUT THE DRAINAGE SYSTEM

Whatever may be said to the contrary, it remains a fact that in order to get the best results from a system of drainage, the work should be laid out with a leveling instrument and executed in accordance with the survey made.

Where the area to be drained is large or where the land is nearly level, greatest care must be exercised if the drainage system is to be successful. No one can be relied upon to guess the grade of a tract to be drained, nor can a tract be efficiently and effectively drained without a thorough knowledge of the land slope, the outlets, the character of the soil, and the carrying capacity of various sized tiles.

To Determine the Grade — A farmer who has observed the flow of surface water and does intelligent thinking on the subject of drainage can determine the course and stake out his own system of drainage. However, if the land is fairly level and the flow of water is slight, as is often the case in marshes, it is well to test the feasibility of the system by employing a surveyor.

Here is a place where farmers can profitably co-operate. It is often a great expense for a farmer to employ a surveyor unless the area is so large that several days are required to complete the layout for a system. Often farmers have small areas to be drained, sometimes not more than ten or fifteen acres. In such cases the cost can be materially reduced if a group of farmers hire a surveyor, each one paying in proportion to the time required at each place.

Farmers Can Do Their Own Surveying — The Agricultural Experiment Station of Wisconsin has devised a simple method which will

enable the farmers to do their own surveying. Where agricultural instruction is given in rural high schools, methods of drainage survey are or should be taught, and valuable help and suggestions can be secured from agricultural instructors; or in counties having county agents, farmers can secure valuable assistance from these men who are at their service. To facilitate the work, the farmers should observe and have a general knowledge of the natural flow of water, the extent of the area that actually needs tiling, and the possibility of an outlet for the water from the area to be drained. This preliminary work will greatly hasten the survey work whether done by a surveyor or by the farmers themselves.

Method of Survey—The method of survey as described by the Wisconsin Experiment Station is as follows: A surveyor's level and tripod may be bought for from ten to fifty dollars depending upon the quality of the instrument. It is not advisable to buy a cheap instrument, and therefore, it is better for five neighbors to join in paying ten dollars a piece for a good instrument than for one to pay ten dollars for a cheaper instrument. A good instrument will give accurate readings on a rod held twenty rods away.

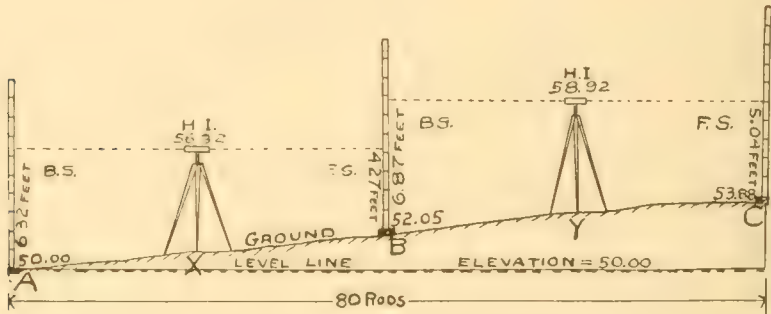

Fig. 1.—Diagram of a Line of Levels.

Suppose that points A and C are 80 rods apart and it is desirable to know how much higher or lower C is than A. Set up the level firmly at X, 20 rods from A, and center the bubble. (The bubble is centered exactly the same as on an ordinary carpenter's level). Have the rod man hold the rod on a firm stake driven flush with the ground at A. Read the rod where a level line from the instrument strikes it. This back-sight reading (B.S.) as shown in Fig. 1 is 6.32 (about 6 feet and 4 inches). This means that the instrument is 6.32 higher than A. Assuming for convenience that A has an elevation of 50.00 the height of the instrument (H. I.) is then 50.00 plus 6.32, or 56.32. Now drive a stake flush with the ground, at B, 20 rods from the instrument, and point the level at a rod held on it. Be sure that the bubble is centered and read the rod for a front-sight (F.S.) which is 4.27 feet, as shown in Fig. 1. This means that B is 4.27 lower than the height of

the instrument. For this reason 56.32 minus 4.27 or 52.05 is the elevation at B.

Then carry the instrument ahead to point Y, about 20 rods beyond B, and set it up once more. With the bubble centered read the rod held for a second time on B. By adding this back-sight reading of 6.87 to 52.05, which is the elevation at B, the new height of the instrument is found to be 58.92. Then by pointing the level at C and reading the rod there, a front-sight (5.04) is obtained, which subtracted from 58.92 gives C an elevation of 53.88. Since A has an elevation of 50.00, it is evident that C is 3.88 feet higher than A. A "line of levels" has been run from A to C.

The following table is a convenient form in which the notes may be recorded. After the height of the instrument has been found, a dozen or more points may be observed from it, and the elevation of any point may be determined by subtracting from the height of the instrument the rod reading taken on the point.

Station	B. S.	H. I.	F. S.	Elev.	Remarks
A	6.32			50.00	Stake at bank of ditch.
B	6.87	56.32	4.27	52.05	Stake 10 ft. from willow tree
C		58.92	5.04	53.88	Stake at fence.

With 58.92 for the height of the instrument, a point on which the rod reading is 7.32, has an elevation of 58.92 minus 7.32 or 51.60. These extra readings are treated as foresights and should be recorded in that column.

Persons using a level should be able to test the accuracy of their instrument. Merely revolving a level half the way around and observing whether or not the bubble remains centered is not a test of this

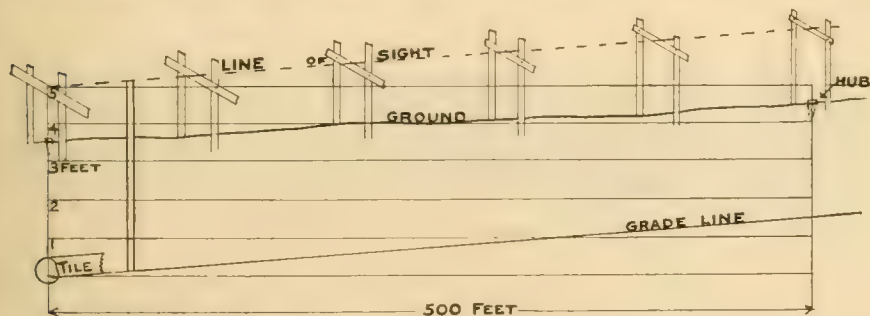

Fig. 2.—Obtaining True Grade Line by Grade Lath Method. The line of sight is five feet above the grade line and parallel to it. By setting the lath stakes at the sides and lining up the cross laths, the grade may be fixed before the trench is dug.

at all. The accuracy of the instrument depends upon whether or not the line of sight is parallel to the bubble tube. If they are not parallel they can be made so by the small adjusting screws and not by the large leveling screws. Until a farmer has been shown how to test a surveyor's instrument and to adjust it intelligently, he is advised to

set up the instrument each time half way between the two points whose difference of elevation is sought, and thus eliminate the error. After the surveying has been done, grade stakes, as shown in Fig. 2, are set up in accordance to the survey made, and thus a uniform slope by sighting can be obtained, which forms the line determining the depth to which the trench must be dug.

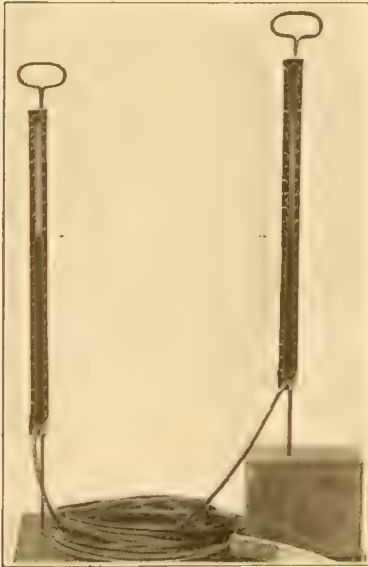

Fig. 3.—A Leveling Instrument.

A simple and inexpensive instrument is shown in the accompanying illustrations. Fig. 3 shows the instrument complete. Water will always seek its own level. This simple and accurate principle is applied in this instrument. The coil contains fifty feet of rubber tubing, which is connected to the glass tubes in the uprights. These uprights are thirty inches long, and are graduated into inches and fractions of inches. Water is poured into the glass tube of one of the uprights until



Fig. 4.—Operating a Leveling Instrument.

the rubber tube is full of water and rises in both the uprights until it reaches about the position shown in the illustration.

Fig. 4 shows the instrument in actual operation on a farm. This farmer is laying out a tile drain. He has his boy with him to take the readings on one of the uprights, and he carries a note book to keep a record of the elevation at each station as he goes along. The white flags are placed on the cut to indicate in which direction he plans to drain the slough.

CHAPTER II.

SUB-SURFACE DRAINAGE

I. METHODS OF DRAINAGE. II. LOCATION OF DRAINS. III. OUTLETS. IV. AMOUNT OF DRAINAGE NEEDED—DEPTH OF TILE—DIAMETER OF TILE AND GRADIENT SLOPE—TABLE FOR CAPACITY OF DRAINS—DISTANCE BETWEEN THE LATERALS. V. DIGGING THE TRENCH AND GRADING. VI. THE TILE AND ITS LAYING. VII. FILLING THE TRENCHES.

Methods of Drainage — There are two forms of drainage in common use: by surface or open ditches, and by tile or sub-surface drains.

Sub-surface drainage of land is accomplished by laying tile of varying sizes and at depths depending on the extent of area to be drained, its slope, and the amount of rainfall in the region.

For surface drainage, open ditches are used which if properly constructed carry off excessive water from the surface of the land; and which if deep enough will, to a certain extent, serve as a sub-surface drain by carrying away water percolating through the sub-surface soil. While there are several types of soil that are directly benefited by surface drainage, yet in loam and heavy clay soils that are impervious to passage of water, and marsh lands where water stands most of the year, sub-surface drainage has shown the most marked benefits. Surface drainage though important is simple. Sub-surface drainage is more complex, and for this reason will be discussed in detail.

Location of Drains — Success in drainage depends largely on the location of the drains. Where the area to be drained is narrow, the best drainage is effected by following the lowest portion of the land. Such areas are often thoroughly drained by laying only one line of tile. Marshes and other areas at the foot of uplands owe their wetness largely to excessive seepage from the uplands. In such cases, the best drainage can be secured by laying the main along some convenient low line and connecting with it laterals along the edges of the marsh, thus catching and removing all the water. If the marsh is comparatively level, the main may be at one of the edges where it will both cut off seepage from one side and receive laterals from the other.

Land which requires drainage always has areas of greater or less size having one point to which all the drainage must finally come. These general areas are again divided into sub-areas, each having its outlet within the limits of the general area. The boundaries of these areas should first be determined, and the plans so made that when the drainage is completed the entire area will have been provided for. Failure to do this is a source of disappointment in drainage work. The main drain should be located in the natural depression, with sub-drains at such points as will furnish outlets for the tributary sections. These are the arteries, as it were, for the

whole system. This work can be carried out in two different ways. The first is to locate branch lines so as to reach those parts of the tract which are particularly in need of drainage such as ponds, "sags," "pot holes," without special regard to systematic work. This is called random field drainage. The second is to supplement the primary network by constructing laterals or side drains parallel to each other and at equal distances apart, according to the requirements of the particular soil, on the theory that every part of the field requires equal drainage.

The most economical system for thorough drainage is that of parallel lines of good length. This will be readily acknowledged when it is seen that, whenever one drain joins another, the soil in the vicinity of the junction has two drains acting upon it in place of one; in other words, it is doubly drained. It would doubtless seem incredible to those who find it necessary to place drains forty feet apart, that other soils can be drained as thoroughly with parallel lines one hundred or two hundred feet apart. In the latter case, however, the side drains should not be less than five inches in diameter.

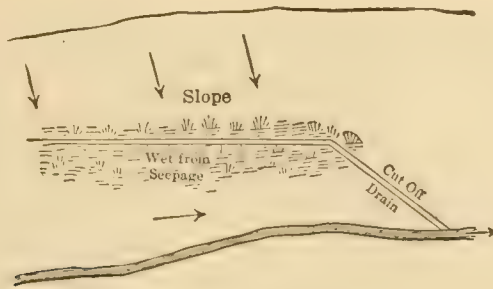

Fig. 5.—Cut-off System.

While, as a general rule, drains should be laid up and down the slope, there are special cases where the other plan is more effective and will accomplish the desired results, sometimes at less cost. A case of this kind is illustrated with Figure 5, which shows a pond surrounded by land with steep slopes. The subsoil of the sloping land is open and porous, absorbing the rainfall readily and permitting water to flow through it to the base of the slope, where, being checked, it accumulates and forms a border of wet ground around the outer edge of the pond. The line located through the center of the pond does not affect this wet strip, since the soil at the outer edge of the pond is less pervious to water than the soil of the hillside. By reason of this resistance and the continual head of water supplied by the hill, the base is kept saturated. An intercepting drain laid near the base is the most effective way of treating such cases. There are also long level sloughs having steep side slopes which furnish a constant supply of water by seepage at the base of the slope. Drains at the upper edge of the saturated strip will intercept the seepage water before it is forced to the surface by the pressure of the water above.

Outlets—The failure of many drainage systems is often rightly attributed to poor outlets. The action of tile drainage is largely dependent upon the distance of its outlets above or below the surface of the water in the ditch, and not dependent on the distance of the tile outlet above the bottom of the ditch, as is often believed.

Though outlets, especially where the tile drainage has good slant or fall and carries a large volume of water, may be submerged for a short time, permanent submersion is injurious to any system. This is true because sediment in the tile drain is deposited in the lower end owing to slower movement of the water and the result is that the whole of the submerged tile will be completely filled with sediment. This,



Fig. 6.—An Outlet Ditch. This was dug with a floating dredge, and is 20 feet wide at the top and seven feet deep. Its slopes are somewhat steeper than is advisable.
Courtesy of the Wisconsin Experiment Station

of course, checks the passage of water. Then, too, submerged tiles crack when the water freezes in them. It is necessary, therefore, to have the water in the outlet ditch fully as low as the bottom of the tile drain. Often where tile drains have their outlets into open ditches in fields or in pastures, the tile is liable to be broken or displaced by the trampling of stock. Such places must be protected. One practice in common use is to protect it by a wooden box covered with a screen. During recent years this has been replaced by using tile of a better quality and of a little larger size at the outlet. Where the soil is easily washed half an hour spent in laying sod at the outlet to prevent washing of the end tile is well paid for.

AMOUNT OF DRAINAGE NEEDED

The depth, diameter and distance apart of tile drains depends on the rapidity with which water will pass through the soil and the kind of crops to be raised. In light, open soils drains may be laid deep and wide apart; in heavy soils they should be laid in shallow trenches and close together, so that the water may readily reach them.

Some crops require much more drainage than others. In some close, tenacious soils, to get good drainage for orchards and garden purposes it has been found necessary to lay the drains not more than thirty-five feet apart. In light, open soils for field crops, drains three hundred feet apart will prove satisfactory.

Depth of Tile — Three feet is the common depth for lines of tile in sticky clay. In sandy subsoil, a tile four feet deep can drain a strip two hundred feet wide as easily as one three feet deep can drain a strip one hundred feet wide. Lines cutting off seepage should be four feet deep, if possible, in all soils. On areas having a fair slope the depth may be uniform from the head to the outlet. On level areas the tiles have to be shallow at the head and deep at the outlet. It can be stated in a general way that four feet is considered deep drainage while two and one-half feet is shallow. The latter depth, however, has been very successfully used on heavy soils.

Diameter of Tile and Gradient Slope — While the size of the main depends upon the size and nature of the area drained, this is not true of the size of the laterals. A lateral has for its work the drainage of a single strip of land from four to eight rods wide. A four-inch tile is usually large enough for a strip of land not more than eighty rods long. Due to the fact that the efficiency of a four-inch tile is so much greater than a three-inch, it is questionable whether it pays to use anything but the former for all lateral drains. For short distances and where there is good slope, three-inch tile can be used to good advantage. To determine the size of the main drain is often difficult. Its size must be determined by the area of the land and not by the size of the sub-drains, for the latter are often not more than half full. The following table prepared by Mr. Elliot is helpful in determining its size:

Table No. 1 CAPACITY OF MAIN DRAINS

Diameter of tile Inches	Fall in inches per 100 ft. of drain.					
	5/8-in.	1 1/16-in.	2 3/8-in.	3 3/8-in.	4 3/4-in.	6-in.
	Acres of land drained					
5	14	19	21	24	27	30
6	22	26	33	39	43	48
7	32	39	48	57	64	70
8	45	54	68	79	89	88
9	61	72	91	106	119	131
10	70	94	118	138	155	170
12	125	148	186	217	244	269
14	184	217	272	318	358	394
16	256	302	379	443	498	549
18	342	405	508	594	668	725
20	445	528	660	771	868	955

This shows the number of acres from which a quarter of an inch of rainfall will be removed in twenty-four hours. Suppose the area to be drained is thirty-five acres. Then a seven-inch tile with a fall of one and one-half inches per 100 feet would carry off the water; or, a six-inch tile with a three and one-half inch fall; or, a five-inch tile with a fall of about four and one-fourth inches per 100 feet of run. This is the amount that could reasonably be expected to drain from a clay soil. The table indicates that a tile with a six-inch grade carries more than twice as much water as one having a five-eighths inch grade. Thus the importance of securing all the grade possible for effective drainage is apparent.



Fig. 7.—Trenching for Tile. Note the line necessary. Only the unskilled workman will attempt to get the ditch straight enough without a line.
Courtesy of the Minnesota Experiment Station.

Distance Between the Laterals— From what has been said so far it will be understood that the distance between the laterals varies considerably. Soils are spoken of as being close and open with respect to their drainage properties. The distance apart will therefore depend on the closeness or openness of the soil. Often the drainage properties cannot be ascertained. In such case it is better to place the drains so that a line of tile can be laid midway between the lines if afterwards the drainage is found less thorough than desired. It can be stated that in general, close soils consisting largely of clay require laterals forty or eighty feet apart, and open soils from eighty up to three hundred and twenty-five feet apart.

DIGGING THE TRENCH AND GRADING

The trench should be started on the surface by a line and must be made clean cut and straight. The line should be stretched tight and extend along the grade stakes. The digging tools which are necessary in easily

worked soils are as follows: A ditching spade with blade eighteen or twenty inches long, a round-pointed shovel with a long handle, a grade stick and a grading scoop of the "pull" pattern. In light, mucky soils a muck spade, which is a three-tined fork with a steel cutting edge like a spade, will be handy. Where the clay is hard and strong a pick or an iron bar will be needed.

Where it is necessary to change the direction of the line it should be done by an easy curve; and where a lateral drain joins another it

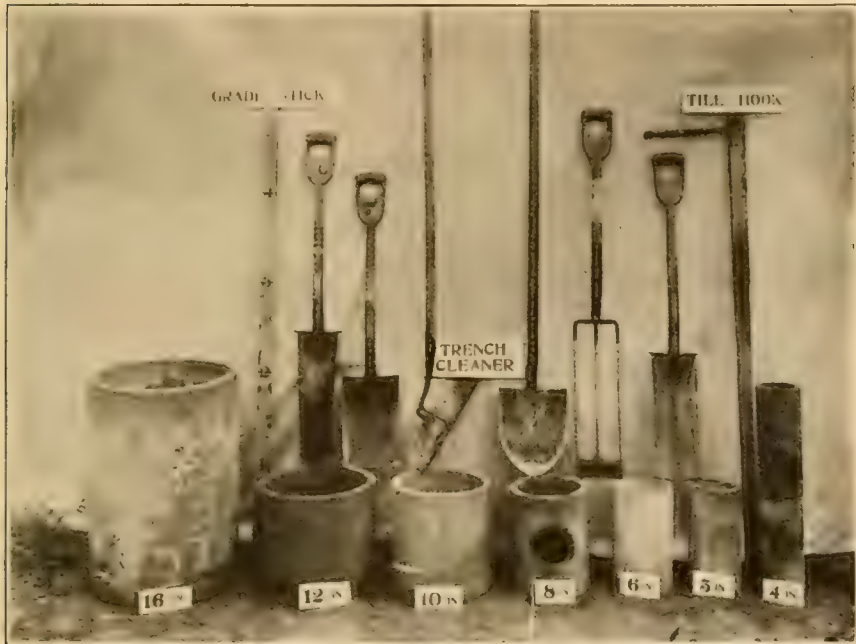

Fig. 8.—Tile-Laying Tools and Samples of Tile. No three-inch tile are shown because the four-inch tile are enough better to more than pay for the slight difference in cost. Prices of tile are quoted in Table No. 2. See Chapter III.

Courtesy of the Wisconsin Experiment Station.

should form an angle of about thirty degrees. The current is checked and sediment deposited if the laterals join at too much of a right angle.

Where possible, the cost of digging the trench can be much reduced by plowing a deep furrow or two in the course of the tile. The rest of the trench, to within an inch or two of the bottom, is cleaned out with a tile scoop. The bottom of the trench is determined by the use of the grade line which extends along the trench, and the grade stick, which is a four- or five-foot rule with a crosspiece on top. This work of trenching should be done by the most experienced and the most careful man on the job, for the exactness of this work determines largely whether or not the system will be a success.

The Tile and Its Laying — The tile should be straight, cylindrical, well burned, and square on the ends. The test for good quality is a

sharp, metallic sound when struck with a piece of metal. The tile used for under drainage is burned clay of various lengths, but the one-foot length is most commonly used. Tile is sold on the market at so much per 1,000. The tiles usually over-run in length from a quarter to half an inch so that a thousand tiles will ordinarily lay 1,000 feet, after broken, crooked and otherwise useless tiles have been thrown out. A crack through the walls at the end two inches in depth, or any irregularity which would decrease the cross section of a drain, or prevent its making a good joint should be sufficient cause for rejection.

When the bottom of the trench has been brought down to its proper level, the tile should be laid as soon as possible, especially in sandy soils where the sand will readily "run in." The tiles should be laid from the outlet up grade. Sizes up to eight inches in diameter may

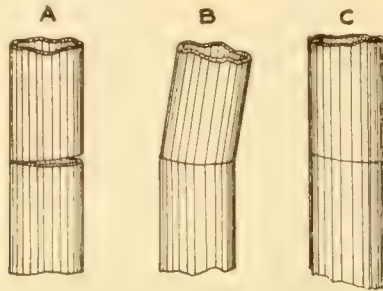

Fig. 9.—Poorly Made and Well Made Joints. Tile with ends that are not square, as at A, should be rotated until the contact is made as close as shown in C, without the kind shown in B.

be conveniently laid with a tile hook, the workman standing on the bank lowering the tiles into place and turning them in the trench until their ends fit closely together at the top. Usually there are openings at the base due to unparallel ends but unless too large they do not in any way interfere with the efficiency of the tile. In curves it is often difficult and sometimes impossible to get a close fit, in which case broken pieces of tile to cover the joints can be used to good advantage. Junction tiles should be laid where laterals are to enter, and these should be "Y's" rather than "T's."

In case water stands in the bottom of the trench and the soil is sandy in character there may be danger of this material passing through the joints and decreasing the carrying capacity of the drain. To prevent this turf, marsh soil, or clay can be used to cover the openings. In clay or marsh soils there is no danger of the tile being filled if properly laid. It frequently happens that tile is laid past trees which the owner wishes to preserve. To prevent roots from entering the joints and filling the interior of the tile, as often happens, it is recommended that the joints be cemented past the point where roots are found in the ground. If tiling is done through willow or other brush land it is always advisable to clear the land a short distance on either side of the trench.

Filling the Trenches — After the tile is laid, enough earth should at once be thrown in to hold the tile in position that it may not be disturbed by any subsequent filling. This is called blinding. It sometimes happens that clay soils “puddle” and thus clog the openings between the tiles. To avoid this, use straw or marsh grass for covering the tile before the earth is thrown in. If the subsoil is sandy then this filling



Figure 10.—Laying 6-Inch Tile In a 4½-Foot Trench. The man standing at the side of the trench is laying tile with a tile hook.
Courtesy of the Wisconsin Experiment Station.

should consist of the more cohesive loam soil from near the surface which can be spaded down. This first filling should be done by a careful man who insists on doing only a first class job. After this has been completed an ordinary plow is sometimes used to good advantage for filling the rest of the trench. A scraper with a long chain is also a common device. In meadow or sod land where the earth has been thrown to either side, a V-shaped scraper with the point behind can fill



Fig. 11.—Tile Drain Ready to Blind.
Courtesy of the Minnesota Experiment Station.

the trench from both sides at one passage without disturbing the turf. This scraper is not good where the soil is sticky and wet, in which case the ordinary road scraper should preferably be used.

CHAPTER III.

COST AND PROFIT OF TILE DRAINAGE

- I. WILL IT PAY?—TABLE FOR PRICE OF TILE—TABLE FOR COST OF DIGGING AND LAYING.
 II. DRAINAGE PROJECTS.

By knowing the value of land, the character of the soil, the cost of tile, the average cost of digging the trench, and laying the tile, a farmer can generally answer the question which arises when he plans to put in a drainage system, namely, "Will it pay?" The price of the tile varies from year to year and in the different localities. Table No. 2, made by the Wisconsin Agricultural Experiment Station, can be taken as a fair price for tile, including freight rates for 100 miles.

Table No. 2 PRICE3, WEIGHTS, AND AVERAGE CARLOAD OF TILE

Diameter in inches	Price, per 1000 ft.	Pounds per foot	Average carload	
			Feet	Rods
4	\$ 18	6	6500	390
5	26	8	5000	300
6	35	11	4000	240
7	45	14	3000	180
8	60	18	2400	144
10	80	25	1600	96
12	120	33	1000	60
14	185	43	800	48
15	200	50	600	36
16	225	53	500	30
20	400	83	330	20
18	310	70	400	24
22	500	100	320	19
24	550	112	300	18
27	800	150	240	15
30	1,000	192	160	10

Prices are not quoted for tile less than four inches in diameter for, as previously stated, less than four-inch tile is seldom used. The size of tile to use can be determined by referring to Table No. 1. (See Chapter II.).

Table No. 3 shows the cost per rod of digging the trench, laying the tile and binding with four inches of earth.

Table No. 3 DEPTH IN FEET

Size of tile	3	4	5	6
4 inches	\$.30	\$.50	\$.80	\$1.25
5 inches	.35	.55	.85	1.30
6 inches	.40	.60	.90	1.35
8 inches	.45	.65	.95	1.40
10 inches	.50	.70	1.00	1.45
12 inches	.55	.75	1.05	1.50

These prices are based on average conditions. When the subsoil is strong and sticky, making digging difficult, the price will necessarily be higher. It is assumed that the farmer board the tilers. It will be observed that the cost of buying and laying four-inch tile three feet deep is about 75 cents a rod. There will be forty rods of tile for each acre

if the laterals are four rods apart, or twenty rods to the acre if they are eight rods apart. Aside from the cost of the main, the cost of tiling on this basis will range from \$15 to \$30 an acre.

DRAINAGE PROJECTS

The benefits of drainage cannot be better illustrated than by showing some plans of drainage projects that have been carried out, the cost of their construction, and the benefits that farmers have derived from such drainage.

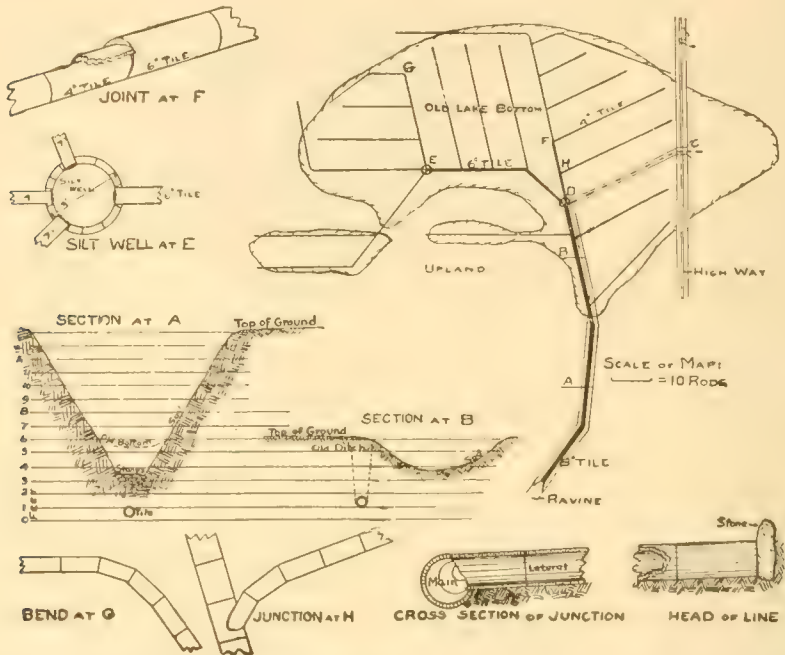

Fig. 12.—A Tile Drained Area of Flat Clay. The laterals on the area mapped in the upper right-hand corner of Fig. 12 shows an area of thirty acres that was formerly an old lake bed, and practically level. Though it had been plowed once during a dry season, no crop had ever been raised. Dead furrows were provided to assist the surface run of water. The drainage of this bed was partly facilitated by an old ditch through the old lake bed, the relation of which to the tile is shown in sections A and B in the illustration. The entire cost of this system was about \$16 per acre of land benefited by the tiling. Three crops of corn were raised on this area in three consecutive years. The crop averaged a little better than sixty bushels of shelled corn per acre, according to a statement by the owner. The yield of the last two seasons exceeded this amount. The flat land can now be worked earlier in the spring than some of the surrounding upland.

Courtesy of the Wisconsin Experiment Station.

The area shown in Fig. 13 was called "good pasture land," but it was so wet that it had never been plowed. The tiles were laid and a field of about twenty-six acres was opened to cultivation although only twenty acres were actually tiled, making the cost of drained land about \$16 an acre. The land was plowed in the spring and put into corn. At no time during that season was any portion of this area too wet to cultivate, except in two or three spots where short lines of tile will have to be laid.

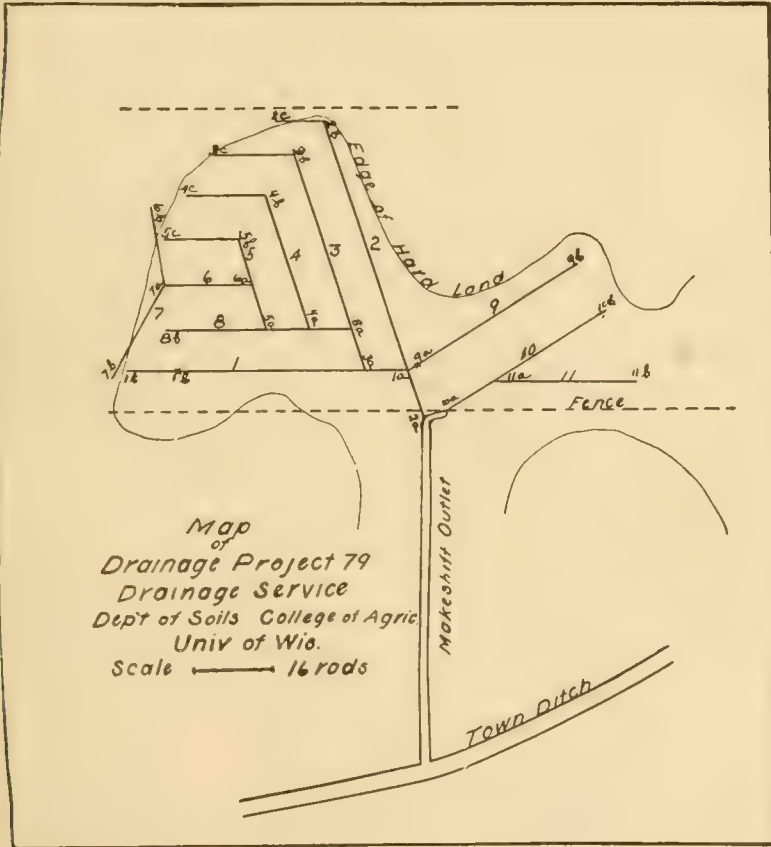

Fig. 13.—Map of a Tile Drainage System.

Courtesy of the Wisconsin Experiment Station.

The corn was cut on September 10 because of danger from frost. However, as there was no frost for two weeks after this, a better yield would have resulted if it had been left to mature. From thirteen acres of the poorest portion of the land, 110 tons of silage were obtained. From the remaining thirteen acres, 500 bushels of shelled corn were secured. The crop of corn was enough to pay for the tile and leave a fair balance to pay for the cultivation. The owner tiled twenty acres adjoining this the following year.

The area shown in Fig. 14 is one of peat and muck, ranging in depth from three to ten feet. A peculiar ridge extending diagonally across the area from northeast to southwest was the wettest and roughest part of the marsh. The bottoms of the finished trenches in the muck and peat were so soft that two narrow strips of boards had to be placed on the bottom to hold the tile in place. Sometimes the tile had to be carried twenty rods by hand.

About thirty acres were made tillable at a cost of \$25 an acre. Owing to the benefit received, the neighbors owning land adjoining on the north, have paid one-third of the cost of the main. The ridge which pre-

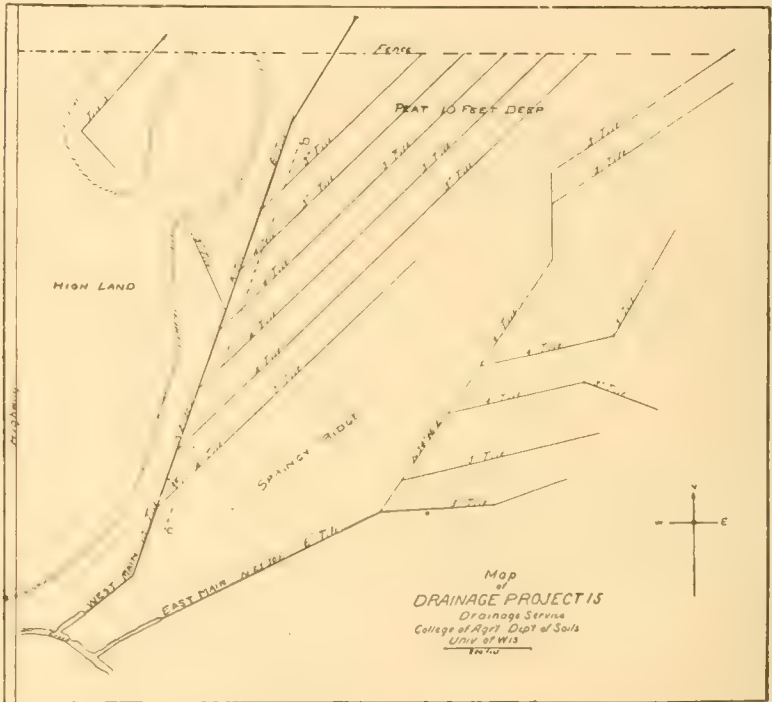

FIGURE 14.—MAP OF A DRAINED PEAT MARSH

The laterals of the west main are four rods apart. Those of the east main are put where they would cut off the most seepage.

Courtesy of the Wisconsin Experiment Station.

viously was so wet, has become quite dry and will probably never need tiling due to the installation of drain tile on either side. Another noteworthy result is that the raw peat in the north central part of the area, by thorough drainage and the use of fertilizers, has been made to produce its share of the 2,760 bushels of shelled corn that the thirty-five acres produced. The owner of this land was so well pleased with the results of his venture that he bought and drained forty acres more of the same kind of land.

Space will not permit mention of numerous other drainage projects,

which have been fully as profitable as these. The following statement by Charles G. Elliot, formerly of the United States Department of Agriculture, has been well borne out wherever tile drainage has been conservatively and systematically used. He says: "I have known of many thousands of acres of land that have been drained, and have never known of an instance in which the money spent for drainage, when thoroughly done did not pay a large return on the investment. An annual profit of twenty-five per cent is not at all uncommon. The question should be looked at in this way: if the farmer owns the land he must pay taxes, keep up the improvements, and procure the necessary help and implements for cultivating it; if there is land which he cultivates at a disadvantage, because it is too wet to yield a full crop, or possibly yields none at all, proper drainage will cause this land to yield a full crop without the expenditure of any additional labor, seed, or capital and the entire increase may properly be regarded as the profit of drainage. It would be easy to multiply examples of the profits which accrue from the practice of soil drainage not only to the farmer who drains his land and cultivates it himself, but also to the capitalist who purchases land which is comparatively worthless without drainage and then improves it in this way as an investment. What has been said, however, will be sufficient to indicate that nothing brings a surer return for the money invested than does the drainage of rich soil."

CHAPTER IV. SURFACE DRAINAGE

- I. EASE AND CHEAPNESS OF CONSTRUCTION. II. METHODS OF CONSTRUCTION. III. SURFACE RUNS IN CONJUNCTION WITH SUB-DRAINS. IV. COST OF MAINTENANCE. V. THE FARMER AS A DRAINAGE ENGINEER.

While surface or open ditches are not desirable in themselves, since the land they occupy can often not be used for any other purpose, and though they often divide the land into inconvenient shape for cultivation, yet they are necessary to every system of under-drainage, and too, their separate use has been very effective in increasing and improving the land for cultivation.

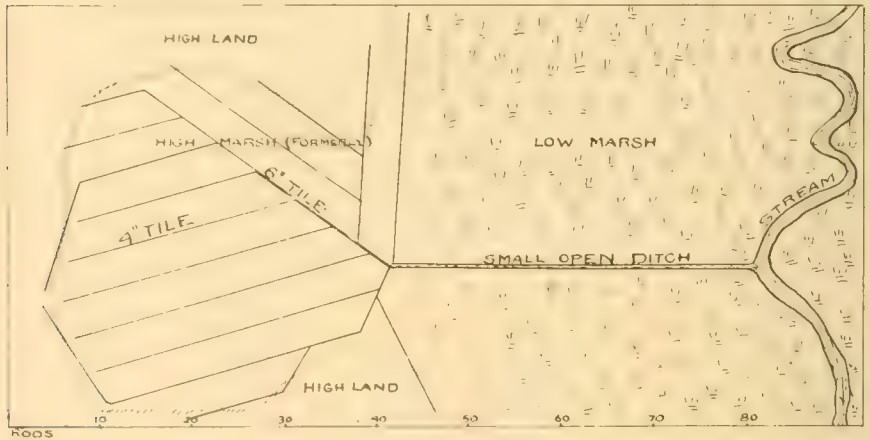

Fig. 15.—Small Open Ditch Properly Located. This serves as a makeshift outlet for the tile system until the bed of the stream is lowered by a dredge. Courtesy of the Wisconsin Experiment Station.

Ease and Cheapness of Construction—The fact that surface ditches can be easily constructed by unskilled labor having no basic knowledge of drainage, and that such ditches can and most often are constructed by farmers when other farm work is slack, account for their popularity and extensive use in the Northwest. Often farm land which is otherwise high, contains numerous sloughs or slight depressions where water collects after heavy rains, interfering with cultivation and frequently injurious to crop growth. Such areas can be drained by a surface ditch often not more than one-half or one and one-half feet deep. In most cases such drainage does not require the assistance of an engineer. After heavy rains or in the spring when the snow is melting, the location and depth of such ditches can be easily determined by the farmer himself. Where the earth is dry, ditches can be constructed by farm-

ers, when other farm work is not pressing at a cost of from six to ten cents a cubic yard.

Methods of Construction—Where the land is so dry that horses can be used, the cheapest and quickest method of making surface ditches is by the use of a push or road grader, or by the use of a plow and slip scraper. When the ditch is not laid out by survey the correct slant and depth cannot always be determined accurately. Each rain will give an idea of the efficiency of the system so that the faulty places can afterwards be corrected whenever convenient.

Surface ditches (unless too deep ridges are to be crossed, in which case tile can be profitably used in conjunction with the open drain) should be made wide enough and with sufficient slope to be easily crossed with farm machinery so as not to interfere with cultivation. In places where the beds are too wet for farm crops, they are often



Fig. 16.—A Well-Sodded Surface Run. For convenience and appearance the sides are well sloped and sodded. Seepage water may be removed by a tile laid beneath or at the side of a run like this.

Courtesy of the Wisconsin Experiment Station.

seeded down permanently to grass, which is used for hay, thus keeping the ditch clean and at the same time getting a return from land which could otherwise not be utilized.

Cost of Maintenance—The question of maintaining surface ditches on the farm is one worthy of at least a brief consideration. It is well known that the deeper the ditch the more constant care and attention it calls for. There are several ways whereby the cost of maintenance can be reduced. One is, as just stated, by seeding down the bed to permanent grass. Another way is to make the ditch as shallow as possible. In places where the portion to be drained is only a short distance from the outlet, or where a succession of sloughs or depressions are drained by the same ditch, it can be made more shallow by hauling the earth from the ditch into the depres-

sions. This can be best accomplished by the use of a wheel scraper. If the distance between sloughs is not much more than twenty or thirty rods, half of the earth can be hauled to the lower depression while the other half is hauled to the next higher and so on, thus filling the depressions. An open ditch where a succession of depressions is drained, requires only a depth of about ten inches for complete drainage, while eighteen inches depth will be needed if the slip scraper or push grader method is used.

The initial cost of such ditching is of course more than where the earth is dumped on the side, but the decrease in the cost of maintenance, and the more tillable character of the ditch by being made more shallow, certainly warrant its use. Economical drainage of large areas can be secured by the use of such ditches, supplemented by the careful planning of dead furrows in the field to be used as laterals.



Fig. 17.—A Surface Run with a Dyke on the Side Toward the Marsh. This is only deep enough to serve as an eave-trough to catch the surface water from the adjacent upland. To intercept seepage from the upland a tile has been laid two feet deeper than the bottom of this ditch, and parallel to it, along the edge of the marsh.

Courtesy of the Wisconsin Experiment Station

Surface Ditches in Conjunction with Sub-Drains—A surface ditch like that shown in Figure 16 is to remove surface water during flood flow, but during the rest of the time it should be dry. Some expensive drainage systems have been partial failures because they have not had the help of an inexpensive surface ditch or run. A surface ditch one and one-half feet deep and eight or ten feet wide at the top can be made with a road grader for about twenty-five cents a rod. Its slopes can be made to raise grass, thereby avoiding waste land as previously stated, or inconvenience in cultivation.

Surface runs or ditches may be used as cave-troughs to prevent the surface water of the surrounding uplands from entering a lower area. These cut-off runs must be commenced high enough up on the slope to give them a descending gradient to a natural outlet. Their efficiency is increased by a dike on the side toward the protected area, such as is shown in Figure 17.

THE FARMER AS A DRAINAGE ENGINEER

The role of a farmer as a drainage engineer may be summed up as follows:

1. He recognizes the need of better drainage on the wet spots of his farm.

2. He studies those spots to learn whether the water is coming on them too fast or going from them too slowly,—whether he should drain by keeping water from entering or by aiding in its removal after it does enter.

3. He learns whether the damaging-water is surface water or soil water.

4. He plans a drainage system that will remedy the cause,—a surface-run for surface water and tile for underdrainage.

5. He stakes out a drainage system in accordance with his plans.

6. He gives the neighbor above him an opportunity to co-operate with him in putting in a main drain large enough to serve the lands of both, each paying for a just portion.

7. He gets a surveyor to test his plans and make changes where necessary.

8. He purchases his tile in carload lots.

9. He superintends the laborers while they lay the tile or gets a contractor to do it for him.

10. He inspects the work in the light of the grade notes left by the surveyor.

11. He covers the tile and clears the land for plowing and cropping.

12. He makes a map of the finished drainage system.

13. He watches the developments and in the following year puts in additional lines of tile or surface-runs where they are needed.

14. He keeps the outlet free from obstructions during the years that follow.

15. With this program, he will find that his drainage work will prove to be the most interesting and profitable of his farm work.



A Dry Farming Harvest.

PART II—DRY FARMING

CHAPTER I

SOIL MOISTURE FOR DRY FARMING

- I. INTRODUCTION—EXTENT OF DRY FARMING REGIONS—DEFINITION AND LIMITATIONS—EARLY EXPERIMENTAL EVIDENCE. II. SOIL MOISTURE—CONSERVATION ESSENTIAL—SOURCES OF WATER—IN THE SOIL—AMOUNT OF CAPILLARY WATER—MOVEMENT OF CAPILLARY WATER—LOSSES OF WATER—AMOUNT REQUIRED FOR CROPS—TABLE No. 1—TABLE No. 2—TABLE No. 3—WIDTSOE'S RULES.

INTRODUCTION

Extent of Dry Farming Regions—Two-fifths of the land area of the United States, two-thirds of Australia, a large portion of the Argentine Republic, and other extensive tracts of the world's land surface have an annual rainfall of less than twenty inches. Newell estimates that in the United States alone there are 600,000,000 acres of arable land in regions of low rainfall where successful agriculture is dependent on the practice of irrigation or the principles of "dry farming." Irrigation is possible in regions of low rainfall providing a source of water is available, but if all the rain that falls on the Rocky Mountains could be held and used for irrigation, it would only supply water for ten per cent of the total arid and semi-arid lands of the United States, leaving ninety per cent of these areas to be farmed by "dry farming" methods if they can be farmed at all.

Definition and Limitations—“Dry Farming” is the profitable production of economic crops, without irrigation, on land of a low annual rainfall. Its success depends largely on methods of soil tillage that conserve and utilize the rainfall of the region to the fullest possible extent, and, also on the use of quick maturing, drouth resistant crops. Dry farming is unprofitable and even impossible on areas having less than ten inches of rainfall annually, or where in a region of more abundant rain, the wind velocity and temperatures are such as to cause excessively rapid evaporation at the critical stages of crop development. The success of dry farming depends as much on having a large per cent of the rainfall come in the growing months, and on a low rate of evaporation during the growing period as on the total annual precipitation of moisture. In those regions of the United States where dry farming has proved most successful, it may be noted that a large per cent of the annual precipitation comes in the spring and early summer and that the high altitudes cause comparatively low temperatures through the spring and early summer. Under these conditions the loss of moisture from evaporation and surface run-off is very small, and such moisture as does fall is largely utilized by the growing crops. There are many immense tracts of land in the states of the plains, the Great Basin states, and the intermountain states that cannot be irrigated but which have enough rainfall (over ten inches) to warrant dry farming, and where the greater part of the yearly rain and snowfall comes in late winter and spring, and thus becomes available for growing crops.

Early Experimental Evidence—Utah, the first state to maintain a successful Experiment Station in a semi-arid climate has demonstrated:

1. That thorough tillage is absolutely essential to dry farming.
2. That by practising proper methods of tillage a large per cent of moisture can be carried over from one season for the next season's crop.
3. That the finest wheats are those grown in semi-arid regions.
4. That, through the planting of drouth resistant crops, the area of dry farming can be greatly extended beyond its present bounds.

SOIL MOISTURE FOR DRY FARMING

Conservation of Water Essential—The chief problem of the farmer in humid regions, where rainfall is plentiful, is to maintain soil fertility. In semi-arid regions the soils as a rule are more fertile than the soils of humid regions, and the primary problem of the dry land farmer is one of moisture conservation rather than the maintenance of soil fertility. All his physical and mental energies must be directed toward saving for the crop as much of the annual rainfall as possible.

Sources of Water—The sources of the soil water are rain, snow, hail, and dew. The rainfall (including snowfall) may be so distributed as to fall largely in one season of the year or it may be evenly distributed through two or more seasons. If rain falls on loose, open soil, more moisture is conserved than if it falls on frozen or hard ground, for on loose soil a

large amount will soak into the subsoil. Snowfall on an unfrozen soil is more desirable than rainfall, because the snow water has more time to soak into the soil before evaporation begins again. A few steady showers are more desirable than numerous light showers, giving the same total rainfall; because light showers merely wet the top soil and dry out again, whereas a considerable part of the moisture from a steady shower will soak into the subsoil.

Water in the Soil — In humid regions, some of the rainfall runs off, but in semi-arid regions it is not so likely to, because it falls on a thirsty soil that is porous and lets the water in easily, if it is in the proper state of tilth. Therefore, it enters the soil and seeps downward until the excess water is all changed into films of water which are formed around the soil grains. These films form a continuous column of water to the surface of the soil. The film tends to remain of the same thickness around all the soil grains with which it is in contact. Now, the sun and the dry air will cause evaporation at the surface, thus reducing the thickness of the film at the surface. The thicker films in the subsoil will rise to equalize the distribution again. This will continue until the films are so thin that the plant roots cannot draw any more moisture from them. The result is drouth. It is the dry-land farmer's business to prevent this evaporation by soil cultivation that will break off the top of the water column exposed to evaporation, and thus protect the main portion of the water films in the soil against the dry air and the sun. This film of water in the soil is known as capillary water and is the source of the plants' water supply; hence, its importance.

Amount of Capillary Water in Soils — The amount of capillary water that may be carried by different soils varies greatly. The larger the soil grains the less will be their surface area, and as a consequence less capillary water will be found in the coarse-grained or sandy soil than in the fine-grained clay soil.

Sandy or sandy loam soils always contain less water than clay soils, when equal chances have been given for the soil to absorb water. But a clay soil containing fifteen per cent of moisture may be as dry from the standpoint of the plant as a sandy soil that contains ten per cent of water. The plant will absorb a larger percentage of the water possessed by the lighter soil.

Movement of Capillary Water — The extent of the capillary movement of soil moisture is of great importance, for upon it often depends the success or failure of the crop. Very sandy soils allow comparatively limited movement of capillary water. If the lower end of a column of sand is placed in water, the water will rise in the sand by capillary attraction only about two feet. When crops are grown in a sandy soil with permanent water located about eight feet below the surface, the plants may suffer as much for moisture as though water were one hundred feet below the surface. The prospective purchaser of a dry land farm should always examine the subsoil to a depth of eight to ten feet for sand and gravel seams which

would check the passage of capillary moisture to the soil occupied by crop roots. When crops are grown on loamy or silty soil eight or ten feet above water, the plants may be able to withstand extreme drouth because capillary moisture will move quickly many feet in this type of soil. Loamy and silty soils are best for the rise of water by capillary movement. Water does not rise so quickly or so easily by capillary movement through clay soils, due to the fineness of the clay particles. This explains why crops may suffer from drouth upon heavy bottom lands at the time that they are thriving upon the higher, lighter soils. In a clay soil, water may not rise rapidly enough from below, during a drouth period, to supply the demands of the plant. Water does not rise nearly so high in dry soils as it does in moist soils, nor is the movement so rapid. Likewise the movement of either gravitational or capillary water is much slower downwards in dry soil.

The dryness of the soil contributes to the slow movement of the water through it in two ways: In the case of the movement of the capillary water, the actual dryness of the soil grains retards the movement of the water. In the movement of the gravitational water, the presence of air in the soil retards movement. For these reasons it is advisable to prevent as much as possible the thorough drying out of a soil, for once thoroughly dried, it takes a long time for it to become wet again.

Losses of Water—When plants are growing, water is lost from the soil in two ways. In the first place, water is evaporated directly from the soil. It has been found by experimentation that on an ordinary farm soil each square foot of area daily lost 1.3 pounds of water by evaporation during the summer months, or over five inches of rainfall in a month. In the second place, water is lost through the plant. In all plants there is a current of water passing upward through the plant, carrying the plant food along in solution. The water enters through the roots in the soil and escapes from the plant through a multitude of small openings on the under surface of the leaves, known as the stomata. The process is called transpiration of water. Water is lost, then, both by evaporation and by transpiration. In growing a crop, it is almost impossible to calculate the amount lost in each case, so that both losses are generally figured as one. However, it is known that almost the same factors that influence evaporation also influence transpiration.

It is difficult for man to modify the loss by transpiration. One method of doing this is by growing certain drouth resistant crops or plants, which transpire less water than do crops or plants that are not drought resistant. The plant itself in most cases is able to modify the amount of water transpired, within certain limits. Under certain conditions the stomata close and transpiration nearly stops. Again, the leaves expose less surface at one time than at another. We are familiar with the fact that during dry August days, the corn leaves roll up each afternoon and unroll during the night. The rolling of the leaf economizes the water of the plant.

But in many cases, it is comparatively easy for man to regulate the amount of water evaporated from the soil while the crop is growing. The cultivation of corn, for instance, decreases the amount of evaporation and thus conserves soil moisture.

Amount of Water Required for Crops—There is great variation in the amount of water required for crops. The differences depend upon external conditions such as weather, and upon the variety or kind of crop used. It is claimed, for instance, that more water is required to produce a crop in arid regions than in the humid regions. It is well established, moreover, that it takes less water to produce a crop of corn than it does to produce a crop of oats, the yields being the same.

Table No. 1 gives some exact data on this feature of crop growth obtained by the late Professor King of Wisconsin:

TABLE No. 1.
AMOUNTS OF WATER REQUIRED TO PRODUCE DIFFERENT CROPS

Crop	Tons of water required to produce 1 ton of dry crop	Acre-inches of water per ton of dry crop
Barley.....	464	4.10
Oats.....	504	4.45
Corn.....	271	2.39
Clover.....	577	5.09
Peas.....	477	4.2
Potatoes.....	385	3.4

The acre-inches of water perhaps can be better understood by calling them inches of rainfall. It should be stated that these figures indicate not only the water transpired by the plants—the amount of water passing through the leaves—but also the amount evaporated from the ground.

A study of this table shows at once that the amount of water required to produce a crop is relatively enormous. The average for all crops is nearly 450 tons of water per acre. A great amount of this water is lost by transpiration through the plant. Attention is called to the fact that clover heads the list in the amount of water used, while corn used the smallest amount. Oats stand next to clover. It has been found that wheat uses about the same amount of water as barley.

Professor Widtsoe of Utah, in his book "Dry Farming," gives the amounts of water required for different crops, as shown in Table No. 2. The amounts as given are for tons of water for each ton of dry matter.

TABLE No. 2.
AMOUNTS OF WATER REQUIRED TO PRODUCE DIFFERENT CROPS

Crop	Tons of water required to produce 1 ton of dry crop	Acre-inches of water per ton of dry crop
Wheat.....	1048	9.22
Corn.....	589	5.18
Peas.....	1118	9.85
Sugar Beets.....	630	5.55

It is seen that the figures given by Widdtsoe are much higher, something like two and one-half times higher than the figures given by King. Assuming that both results are equally correct, it is apparent that Utah conditions necessitate the use of a larger amount of water than do the Wisconsin conditions. The evaporation conditions are certainly more severe in Utah, and it is claimed by Widdtsoe that a greater amount of transpiration occurs in the arid and semi-arid regions than in the humid regions.

King has prepared a table showing the amount of water required to mature different yields of wheat, assuming that the soil was moist in the spring. The following is a summary of the table:

TABLE No. 3.
LEAST AMOUNT OF WATER REQUIRED TO PRODUCE DIFFERENT YIELDS OF WHEAT
PER ACRE WHEN THE CROP CONTAINS 40% OF GRAIN.

Bushels per acre	Total weight of crop, tons	Water used acre-inches
15	1.125	4.5
20	1.5	6.
25	1.875	7.5
30	2.25	9.
35	2.625	10.5
40	3.	12.

It is evident from this table that a high yielding wheat crop could use nearly all the rainfall of the average western semi-arid region without allowing for any evaporation at all, and it becomes apparent that moisture must be conserved and evaporation checked to as great a degree as it is possible, if sufficient water is provided for the needs of this crop.

Widdtsoe's Rules for the Dry Land Farmer — In order to accomplish such water conservation and make a success of dry farming the dry-land farmer may be guided by the following rules which may be called Widdtsoe's "Gospel of Dry Farming."

1. Plow deep, and plow once for each crop.
2. Plow in fall; there is no need for spring plowing.
3. Cultivate in early spring and in so far as possible after every rain.
4. Fallow land every other year when the annual rainfall is 12 to 15 inches; every third year under an annual rainfall of 15 to 20 inches.
5. Grow drouth resistant and early maturing crops.
6. To attain success, stick to a few staple crops such as wheat, oats, barley, rye, and alfalfa, and when these are well established turn to others.

CHAPTER II

TILLAGE OPERATIONS

- I. THEORY OF THE DIRT MULCH. II. PACKING THE SOIL. III. IMPORTANCE OF PLOWING. IV. TIME OF PLOWING. V. DEPTH OF PLOWING. VI. DISK PLOWING. VII. SUBSOILING OR DEEP TILLAGE. VIII. DISKING STUBBLE GROUND BEFORE PLOWING. IX. TILLAGE AFTER PLOWING. X. VALUE OF A COMPACT SEED-BED. XI. INTERTILLAGE.

Theory of the Dirt Mulch—If a layer of straw, manure, leaves, grass, sawdust, or even stones be scattered over ground containing some moisture, but rather dry at the surface, a marked effect will be noticed in a few days.

The upper few inches of soil will be seen to have accumulated moisture. The moisture thus accumulated would have been given up to the air and lost to the soil had not the covering of straw been applied.

A layer of dry soil applied to land acts in the same manner as the layer of straw. Because a layer of dry soil may be applied to land from the land itself makes the use of the dirt mulch of almost incalculable value.

The main principles for governing the dirt mulch are as follows:

1. The effectiveness of the dirt mulch increases with its depth. The practical limit of effectiveness is probably three or four inches.
2. Increasing the depth of the dirt mulch decreases the amount of available fertile soil.
3. The dirt mulch decreases in efficiency with age.
4. The crumb form of the dirt mulch has a greater resistance to wind action than the dust form.
5. The crumb form of the dirt mulch is more effective than the dust form. (According to King.)
6. Dirt mulches are properly made when the soil is moist.

Packing the Soil—Packing or solidifying the soil has a very appreciable effect on the movement of soil moisture. In the movement of capillary water it is absolutely necessary that the soil particles be very close together. The flow of capillary water is increased by reducing the spaces between the soil grains, or by packing the soil.

King has shown that with the use of an ordinary flat roller, the moisture of the soil may be affected to the depth of fifty-four inches. The first effect of rolling, by increasing the capillary movement of water, is to cause the upper layer of soil to become wetter and the lower layers to become drier. If, after rolling, the surface of the ground is allowed to remain firm, the movement of the water continues until the whole soil column becomes

drier than it was before rolling. Rolling the soil, then, increases the surface moisture at the expense of the moisture in the deeper layers, and finally decreases the moisture in the entire column.

The practice is only allowable in semi-arid regions when moisture from the sub-surface can be spared for the use of the top surface or when a capillary connection with the unplowed soil is to be made. If the subsoil is comparatively dry, it may be a very bad practice to reduce its water supply. It should not be forgotten that the deeper stored water is much less liable to evaporation than the water next to the surface, and it should also be kept in mind that roots of field crop plants go deep in semi-arid regions, so that the deeply stored water may be as efficient as the water near the surface. Corn roots penetrate a dry soil to a depth of eight feet, the small grains to a depth of four feet, grasses five and one-half feet, and alfalfa to an even greater depth.

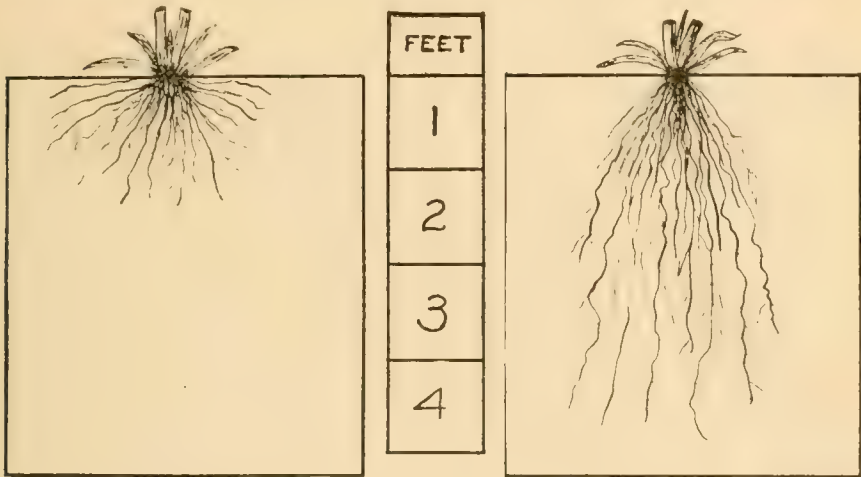

Humid Region

Semi-Arid Region

Fig. 1.—Showing Depth to Which Roots Ordinarily Penetrate.

Consequently destruction of the shallow roots in semi-arid regions does no harm, for other roots are feeding far down in the moist fertile subsoil away from the scorching sun. It is found in semi-arid regions that there is a tendency, particularly for the third foot, to become very dry at the time of crop maturity. It might be well not to induce the upward movement of stored water at or immediately before the sowing of the crop.

When the soil is to be firmed, it is better to use a tool that leaves the surface rough or that does not interfere with the soil mulch already formed. There are various kinds of corrugated rollers, combination rollers and packers, and sub-surface packers. The weighted disk harrow with disks set straight, serves well as a sub-surface packer. The soil should be firmed enough to establish a good seed-bed and to establish capillary connection between the newly plowed and the unplowed soil. This is especially true

when manure, trash or heavy stubble has been plowed under. The sub-surface packer, or any tool that firms the soil, probably does good work in reducing the air spaces of the soil, thus hindering its drying out, provided always that a dirt mulch be left upon the surface.

The press drill is a tool which practically adds the value of the roller to the drill. The soil is pressed only where the seeds are buried, thus leaving a mulch between the rows of grain. The pressing of the soil around the seeds tends to bring moisture to them and to hasten germination.

Importance of Plowing—Plowing is a very important feature of crop production, especially in semi-arid regions. Poor plowing is one of the chief causes for low crop yields, and in semi-arid regions may be the basic cause for crop failure. King states that the work of the plow is two-fold; to bury the weeds and other trash to where they will be converted into plant food, and secondly, to so alter the texture that a deep and mellow layer of earth is formed from a comparatively hard soil.

The effect of the plow, when the soil is in proper condition, is to shear the soil into thin layers, and this shearing is an efficient form of cultivation. This is illustrated by taking many pages at the corner of an open book and bending them over. It is the tendency of the plow to force the different layers of soil past one another, as the pages of the book are forced. When the soil is too wet, and especially if the soil is heavy, the plow, instead of forcing the soil into layers, destroys the soil crumbs or granules, thus puddling or compacting the soil. Plows with steep mouldboards have the greatest pulverizing action upon the soil. The plow with the less steep mouldboards has less tendency to puddle the soil and is of lighter draft than the former.

Time of Plowing—The plow is perhaps the most efficient tool we have in forming a soil mulch. The loose layer of soil formed by plowing effectually prevents the surface evaporation of soil moisture that has risen from the deeper layers of soil. The time of plowing is of great importance in semi-arid districts. When plowing is to take place between two successive crops, the plowing should be done as soon as possible after the first crop is removed, in order to prepare the soil to absorb the maximum amount of autumn rain and winter snow.

Fall plowing has many advantages over spring plowing for the dry land farmer; chief of which are:

1. Fall plowed land absorbs winter rains and snows better than hard, unplowed land.
2. Fall plowing exposes the upper soil area to the disintegrating action of frost, which mellows the soil.
3. Fall plowing permits the ground to settle during the winter and form a compact seed-bed having good capillary connections with the moisture of the subsoil.

Plowing in fall is an excellent rule, but it often needs some modification. Plowing should not be done when the soil is dry. In semi-arid regions

the soil at harvest time is generally too dry for good plowing, and yet if the stubble be left uncultivated this dry condition may become even worse and weeds also will grow and go to seed readily in the uncultivated stubble after removal of the crop. The use of the disk harrow to form a mulch upon the newly made stubble will generally put the soil in good condition for plowing when the cooler temperatures and rains of the autumn season arrive.

Storing the moisture from winter's snow in the soil and subsoil is of great importance to the dry land farmer. If the land can be put into favorable condition for fall plowing, it is decidedly poor policy to let the land go untouched until spring, because the fall plowed land will absorb the melting snows to a much greater extent.

It is usually advisable to leave fall plowed land in the rough furrow, because more soil is exposed to the weather and rains are absorbed more quickly and with less loss from surface run-off. If the plowing is smoothed at this time of year, the first rain will usually create a hard, packed surface, especially so if bright sunshine follows soon after the rain, and then subsequent rains will run off and not enter the soil as completely as in case of rough plowing. Farrel, at a Utah station, observed that on such a packed soil only $\frac{1}{4}$ inch or 19.2% of a 2.6 inch rainfall was absorbed by the soil, while on unplowed stubble land adjoining 60% of the same shower was absorbed. Plowed land in the rough will soak up even more than the stubble soil. On sloping lands it is best to plow at right angles to the slope and to turn the furrows up hill. In this condition plowed land is a very efficient sponge and the rough furrows will check excessive soil washing.

It often happens that autumn weather conditions, or a rush of threshing and marketing work, prevent the dry-land farmer from accomplishing all his plowing in the autumn. Whenever spring plowing becomes a necessity, great care should be taken to check the rapid evaporation of soil moisture that spring temperatures and air currents facilitate. Spring plowing should be done as early in the spring as the ground is fit to work, and in the semi-arid regions the plowing should be packed down the same day as plowed to crush out the air spaces and prevent drying winds from entering into the seed-bed. Such packing may be done quickly and efficiently with the common disk harrow, weighted, and with disks set straight ahead. The Campbell sub-surface packer also performs this work properly. Shortly after the land has been plowed and packed a harrowing crosswise of the furrows will further assist in closing air spaces, creating a dust mulch and keeping out the wind. If spring plowing is handled in this manner, and, furthermore, is harrowed occasionally during the spring months following the heavy rains, moisture will be conserved nearly as well as in case of fall plowing.

Depth of Plowing — It is impossible to lay down any hard and fast rule governing the depth of plowing. Much depends upon the character

of soil and subsoil, the climatic conditions, the crop to be grown, and the time of year when the plowing is to be done. Generally speaking, heavy clay soils should be plowed deeper than light, sandy soils, in order to promote circulation of the air, warmth, and bacterial activity in a type of soil that is likely to be cold and sour. Deep plowing on sandy soil, which is naturally porous and open, is undesirable, because it tends to disconnect the seed-bed from the subsoil and to facilitate evaporation by permitting too free circulation of air in the soil.

Experience has proven that for clay loam and prairie loam soils, plowing to the depth of six to eight inches, gives the best results. In semi-arid climates especially, the greatest advantage to be gained by thorough and deep plowing (six to eight inches) is the development of a comparatively large reservoir for the reception of moisture. Whenever land is not plowed more than three or four inches deep for a period of years, a hard plow sole is very likely to form, through which rains and roots penetrate with difficulty. A mellow depth of but three or four inches allows only a comparatively small amount of water to sink in rapidly during a rain storm, or during a short period of warm weather when snow is melting rapidly.

Observation has shown that if a soil which has been plowed only four inches deep becomes dried out during dry weather, then a rain of three-fourths of an inch is sufficient to bring that depth to a point of saturation. A torrential rain will not readily sink into the hard soil which has not been plowed, and, as a consequence, a torrential shower of one inch, which is likely to occur about once a season, would run off in part. If the plowing had been done to a depth of eight inches, nearly twice as much rain could be taken into the soil before the point of saturation would be reached and a surface run-off started. Furthermore, deep plowing has a tendency to increase the depth of bacterial action, and to thus promote those chemical readjustments in the soil which release available forms of plant food for crops. The depth of plowing should be varied from year to year in order to check the tendency of a plow sole to form. A plow sole will decrease the water-holding capacity of a soil, retard the growth of roots, and check the capillary rise of water from the subsoil.

A sudden increase in the depth of plowing on many clay and prairie loam soils will cause poor crops for one or two seasons thereafter. When the subsoil contains more lime than the old furrow-slice no bad results accrue from a sudden increase in the depth of plowing, but if the subsoil is acid the turning up of several inches of new, acid soil checks crop growth until such time as tillage and weathering influences have decayed and neutralized the new soil. In humid regions the majority of subsoils are somewhat more acid than the surface soils and for this reason when an increase in the depth of plowing is contemplated, it is best to plan to increase the depth gradually (about one inch per year), rather than to lower the plow several inches at a time. A sudden increase in the depth of plowing for soils having acid subsoils may be accomplished safely and with good re-

sults if the soil is thoroughly limed (one ton per acre of ground limestone) after plowing and the lime thoroughly disked and harrowed into the furrow-slice. The lime will neutralize the acidity of the new soil and increase its productivity. In semi-arid regions the majority of subsoils contain an abundance of lime. Therefore new land can be broken deeply or the depth of plowing increased quickly on old land, to a practical depth of six to eight inches, with no danger from bringing up an excess of acid subsoil into the seed-bed. Deep plowing in semi-arid regions should preferably be done in the autumn so as to permit the loosened soil to naturally become compacted and connected with the subsoil during the seasons of the year when evaporation is at the minimum and when it is desirable to increase the absorbing capacity of the soil to the fullest possible extent.

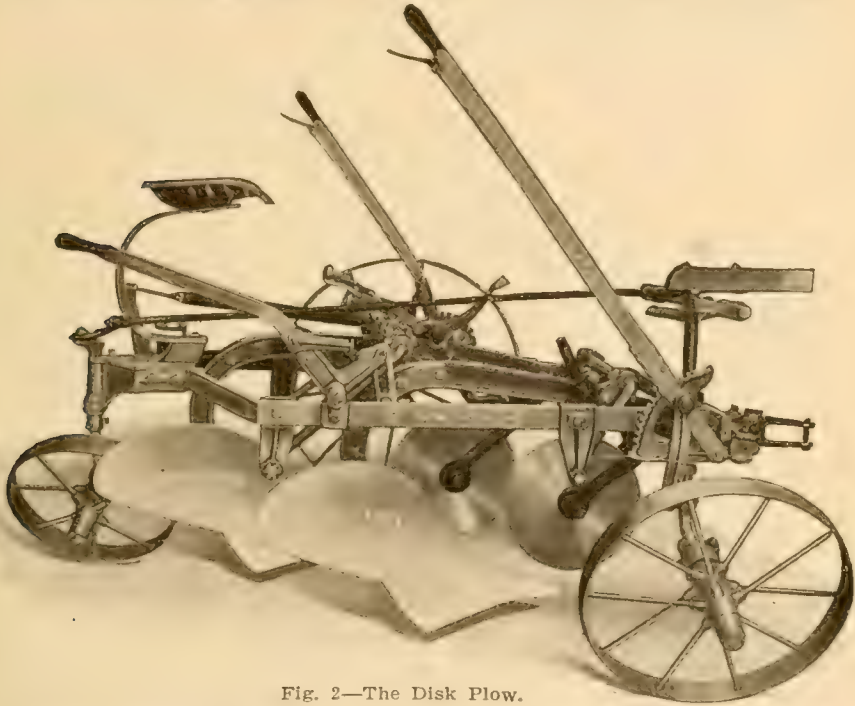

Fig. 2—The Disk Plow.

Disk Plowing—The disk plow is often recommended for semi-arid regions, because it can be made to work in soil that is too dry for the use of the mouldboard plow. Good plowing and harrowing, however, can only be done when the soil is neither too wet nor too dry. Unless an abundance of rain falls on dry-plowed land prior to the seeding of the crop, the crop is apt to suffer severely by reason of a slow and uneven start. If plowing is done in very dry land, the soil is turned over in lumps and is not properly sheared into layers. A lumpy seed-bed is formed rather than a mellow one, and it takes a relatively large amount of work to transform the lumpy seed-bed into one of good tilth. Soil should not be plowed when dry, if avoidable. If for any reason, it becomes necessary to plow

the land when dry, the disk plow is preferable to the mouldboard plow, providing the work is well done. Much poor work is done with the disk plow because the disks are set to cut more land than they are able to cut clean and properly pulverize. When the disks are set too wide, various stubs of land are left uncut and unpulverized just under a shallow covering of pulverized soil. These various strips of uncut soil become a source of trouble in the seed-bed, for crop roots cannot easily penetrate them, weeds accumulate, and they assist the evaporation of moisture from the subsoil. If the disk plow is to be used in dry soil the disks should be so adjusted as to cut various furrows and yet enter the land at a wide enough angle to cause clean cutting at the bottom of the furrow-slice and to lift and pulverize the soil. Very good plowing can be done in dry soil with the disk plow providing proper adjustment is given the disks. The cost of plowing is of course greater than for cut-and-cover plowing, but the

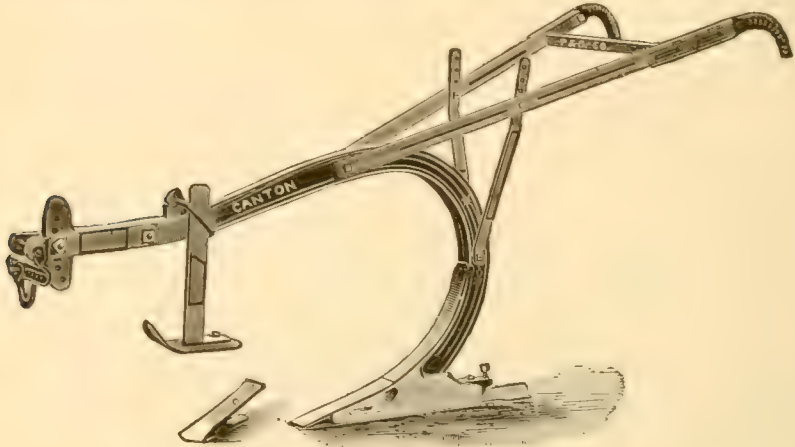

Fig. 3.—Subsoil Plow. Note steel point that can be removed for sharpening.

results justify the additional cost. When the soil is moist, a cleaner job of plowing with more thorough pulverization of the soil can be done with the mouldboard stubble plow than with the disk plow. The disk plow is of lighter draft and has special value in breaking up the plow sole, if one has been formed through many years of shallow plowing with the mouldboard plow.

Subsoiling or Deep Tillage—Theoretically it would seem that if plowing to the depth of six or eight inches in the semi-arid climate is a better practice than to plow to a depth of three or four inches, an increase in depth to twelve or fourteen inches would be still more profitable. It is possible to plow land to these depths, if desired, with the modern disk, deep tillage plow and to pulverize the soil very thoroughly. The cost of deep tillage is considerably higher than for ordinary plowing (averaging five or six dollars per acre), and yet it would not require a very large increase of crop to pay for this additional cost.

Deep tillage in the semi-arid climate would reasonably be expected to greatly increase the water-holding capacity of the soil and to give crop roots a great area in which to extend themselves for moisture and plant food, thus producing an increase of crop that would more than pay for the extra cost of preparing the land. But experience and experimentation with deep tillage in the semi-arid climate do not always bear out the theory. In the majority of trials made the results were unsatisfactory. In some instances deep tillage proved profitable in very wet years and very unprofitable in dry years.

The subject of deep tillage in dry farming practice has not yet received sufficient attention to provide us with full information. From what we now know, it would appear that while deep tillage increases the absorptive power of the soil, it also hinders the movement of capillary moisture and increases the evaporation of moisture during dry, hot weather. While the loose, deep seed-bed provides a comparatively large space for root development, the roots will not be extensive if the soil is dry and loose, and thus the crop is stunted in a dry year.

So many of the soils of the semi-arid climates are naturally loose and loamy that there is no need of plowing deeper than six inches to provide a good physical condition in the seed-bed and to put the soil in shape to absorb rain and melting snow. There are types of heavy soil occasionally met with in semi-arid climates that would probably be benefited by deep tillage, provided the plowing was done in the fall in order to permit the soil to settle for some time before seeding. Deep tillage in the spring would be a risky operation, as a rule, for it would cut off the capillary connections with the subsoil and leave the top soil very loose and subject to evaporation. While packing and harrowing would overcome these conditions to a certain extent, the better practice is to perform the plowing in the autumn and allow time for the deeply plowed land to absorb moisture and to settle down on the subsoil.

If deep tillage is contemplated in the semi-arid climate for the purpose of improving the physical texture of a heavy, stiff soil, or to break up a hard-pan, it would be best to do the plowing in the autumn of the year, and then to bare fallow the land the following year until seeding time for winter grain. Two winter and spring seasons would thus elapse before the land would have to mature a crop, and during this period the soil would be absorbing moisture and compacting sufficiently to provide the desirable physical condition for grain roots. As occasional fallowing for the purpose of conserving moisture is a desirable practice in dry land farming, the work of deep tillage may be planned to precede the fallow year and to thus avoid the bad features of deep tillage that arise when the crop is sown too soon after the land is loosened up.

Deep tillage sometimes causes poor crops because it brings up portions of acid subsoil into the upper part of the seed-bed. Acid subsoils are far more common in humid climates than in semi-arid climates. The dry land

farmer will rarely have to guard against this feature of deep tillage. In instances where the subsoil is known to be of different character from the top soil it is wise to have the subsoil tested for acidity before undertaking deep tillage. Such acidity, if present, can be corrected after the land is plowed, by top dressing the land with ground limestone and disking the lime into the soil.

For the great majority of dry land farmers, deep tillage is not an essential or profitable practice. An occasional heavy, stiff soil may be found, or a soil area handicapped by a hard pan near the surface, that would be benefited by deep tillage. As a rule, good, thorough plowing with the mouldboard plow to the depth of six or eight inches will bring the best results for the dry land farmer.

Disking Stubble Ground Before Plowing — Ripening grain uses but little water and, moreover, protects the soil from wind and sun, but when it is removed, the evaporation of moisture is greatly facilitated. Hence,

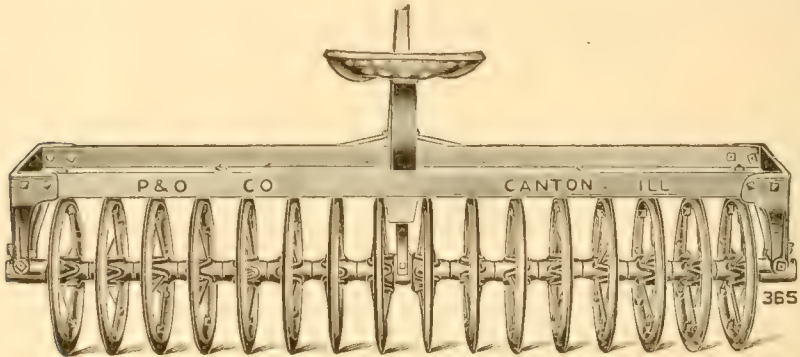

Fig. 4.—16-Wheel Sub-surface Packer. On rolling land it is better to use one that has 3 sections with 6 to 10 wheels per section.

it is very important to check this evaporation of moisture from the soil, in so far as possible by tillage. It is usually too dry to plow at this time, but if the stubble ground is disked soon after the grain is removed, a mulch of crushed straw and dirt will be formed that will materially check evaporation, transform the surface soil into a sponge, and put the soil in good condition for plowing at a somewhat later season. On many well-equipped and well-organized dry land farms it is customary to keep the disk harrows at work in the same field with the binders at the harvest season. Moisture is very precious to the dry land farmer and every safeguard that can be thrown around its control means an increase in the chances for securing a profitable crop.

Tillage After Plowing—When stubble ground has been spring plowed, either in preparation for spring sowing or to remain fallow until autumn for a seeding of winter grain, the land should be packed as soon as possible after plowing to fill up the air spaces resulting from the work of the plow. A weighted disk harrow with disks set straight ahead, or

the Campbell sub-surface packer, will accomplish this, and at the same time pulverize the clods, pack the furrow slice against the subsoil, and leave sufficient loose soil at the surface to form a fairly good dust mulch.

The escape of moisture from newly plowed land in the spring is extremely rapid in semi-arid regions, if the warm, dry air currents are allowed to penetrate into the plowing for any length of time. For this reason, the land should be packed and harrowed as soon as possible after plowing to reduce evaporation to the minimum. In fact, it is almost imperative that such work be done the same day as the plowing. When two or more teams are plowing, for example, one team should be packing and harrowing immediately after the plows. On a small farm where one man and his team are doing all the field work, the day's work should be so planned as to provide for time to pack and harrow each day's plowing before nightfall.

Many of the new types of sulky and gang plows have cultivator attachments that harrow each round of plowing as fast as the plowing is done. This attachment is an excellent one for the dry land farmer to use. Plow mouldboards leave a smooth, glazed surface on the exposed side of the furrow slice, especially when working in clay soil, and if this surface is allowed to harden, an ideal condition is provided for rapid evaporation of moisture from the plowing. The harrow attachment on the plow will prevent this hardening of the furrow surface at no additional expense, but it will not pack in the larger air spaces or quickly settle the plowing upon the subsoil. Such work must be done with the sub-surface packer or the weighted disk harrow with disks running straight ahead. The ideal combination for tillage after spring plowing in the semi-arid climate is the harrow attachment on the plow to perform the first operation; the sub-surface packer for the second operation which should be carried out soon after the first; and the common spike-tooth harrow to harrow the land occasionally thereafter. By these means the greater part of the moisture in spring-plowed land will be conserved.

When spring breaking is done in preparation for a spring-sown crop of flax or a fall-sown crop of wheat similar precautions should be used to check the rapid evaporation of moisture. Many large air spaces are always left in the broken sod, and it takes but a day or two in warm, dry weather to dry out the furrow slice badly when the breaking is left open to the sun and wind. Newly broken land should at least be packed down the same day as plowed, and, if possible, disking and harrowing should also closely follow the breaking. The best device for packing sod breaking is the sectional Durham packer. When this heavy machine is run over the breaking all air spaces are closed up, the ribbons of sod are pressed down tightly on the subsoil, and a fairly good dust mulch remains on the surface. A home-made smoother or float can be made of heavy timbers that will serve much the same purpose as the Durham packer, weighted and drawn over the breaking. When sod is being broken by means of the

traction engine, the ideal plan is to attach the packer or float behind the plows and thus to plow and pack at one operation. In fact, when large engines are being used, it is good policy to lift out several plows from the gang and utilize the power for the packer and disk harrow both, thus leaving the land firm and fine and thoroughly prepared to resist evaporating influences.

Where stubble ground or sod has been fall plowed and the furrows left rough and open to catch the winter snow and rain, the land should be disked and harrowed as early in the spring as it is possible to work the soil. In many of the semi-arid climates the frost leaves the upper three or four inches of soil very early in the spring, and as soon as this occurs the dry-land farmer should be out working down the fall plowing at a time when evaporation is not rapid and before the real rush of spring work commences. Fall plowing, disked and harrowed early in the spring, and sown early to flax, early oats, or bald barley, gives a much greater assurance of crop than spring plowing for these same crops.

Value of a Compact Seed-Bed — The seed-bed for small seeds needs to be finer, mellower, and firmer than the seed-bed for large seeds. In preparing ground for alfalfa, for instance, it is necessary to put much more work upon the land than if the ground is being prepared for a crop having larger seeds.

In semi-arid regions the firm, well-pulverized seed-bed is of distinct advantage for any crop. If the upper six or eight inches of soil is loose and cloddy, moisture will be lost more readily than if the soil is compact. The air, as it is forced in and out of the moist soil by wind currents, becomes a soil-drying agency. For each entrance and exit of the dry air, the soil loses moisture. Therefore, a compact seed-bed is one safeguard against loss of moisture because it prevents too free circulation of air. It should not be forgotten, however, that the surface of a well-firmed seed-bed should be kept in a mulchy condition to prevent the loss of moisture.

Inter-tillage — Crops which may be inter-tilled during the summer months are of special value to the dry-land farmer, because under semi-arid conditions, surface cultivation of the soil is of prime importance in preventing the loss of moisture, and by means of inter-tilled crops, cultivation may be carried on much further into the summer months than in case of thickly sown crops.

In addition, surface cultivation during the summer months is of great value in killing weeds, and in controlling the movement of air in the soil. The oxygen of the air is necessary for the proper growth of the roots, and for the support of certain bacteria which are preparing nitrogenous plant food for the use of crops. Lack of sufficient air in the soil is as detrimental to crop growth as a lack of sufficient moisture. When soil is occasionally stirred at the surface during the growing months, as is the case with inter-tilled crops, a condition of soil tilth is maintained that checks rapid evaporation of the moisture and at the same time permits sufficient movement of

air to meet the requirements of soil bacteria and crop roots for oxygen. Summer cultivation of the crop accounts for a wonderful increase in plant growth because moisture is conserved and plant food liberated.

As one purpose of inter-tillage is to destroy the weeds, the cultivating should be undertaken when the weeds are small, before they have thrown out more than two or three leaves. Another value to be gained by cultivation is the increase of available plant food in the soil, brought about largely by the formation of nitrates by bacteria. Cultivation for this purpose should be undertaken during the early period of the plant's growth, and should be relatively deep, say two to three inches. The third and chief benefit to be derived from inter-tillage is the conservation of soil moisture. In semi-arid climates June is commonly one of the rainy months, and also the month when inter-tilled crops should receive the greater part of their cultivation. Thus it is possible to stir the surface soil often during the season of heavy rains, and check evaporation by means of dust mulches formed soon after the rains have soaked into the land. Such summer cultivation is of course impossible with thickly sown grain crops.

Let us suppose that from the rains of May a quantity of water has been stored in the soil. This water will rise by capillary attraction to a point near the surface of the ground, but will be held in the soil providing a soil mulch has been formed. It now requires but a slight rain to form capillary connections between the stored water and the surface of the ground. After the ground is wet from the surface to the level of the stored-up water, it takes but a very few drying days to cause the escape of a large quantity of water, so that the soil may be drier thirty-six hours after a light rain than it was previous to the rain, or than it would have been had no rain occurred, unless the land is again cultivated in time to throw a dust blanket over the new supply of moisture.

Later in the season, when the period between rains is longer, a deeper layer of dry soil forms near the surface of the ground, making a more efficient mulch for such stored-up water as may still remain in the subsoil. In such cases light showers may not act injuriously in abstracting the stored water of the deeper soil layers, and cultivation after every small rain is not necessary. It is well known in the semi-arid regions that if the crop has a relative abundance of stored moisture upon which to draw, it can pass through long periods of drouth without much injury.

In the case of inter-tilled crops the surface cultivation during June conserves much moisture that the crop can utilize during the drouthy periods of the growing season. Spring grain crops, thickly sown, often fail in semi-arid climates when a spring-sown, inter-tilled crop would produce a profitable crop because the tillage after planting conserves moisture during late spring and early summer.

All cultivation for the purpose of storing moisture and increasing fertility should be as level as conditions will permit. Soil in rough ridges dries out more rapidly than soil with a level surface because a greater soil area

is exposed to the wind and sun. It should not be forgotten, also, that where the soil is left rough, the fertility of the increased amount of the dry soil is lost to the plant, for when the soil is dry fertility is not available. For these reasons the "hilling" of corn or potatoes in the semi-arid climate is a poor practice.

In addition to such standard inter-tilled crops as corn, Kafir corn and potatoes, the dry land farmer can also use the proso or hog millets, Sudan grass, sweet clover, and alfalfa as inter-tilled crops. Proso millet sown in the spring as an inter-tilled crop will rarely fail to produce a profitable yield of grain. Sudan grass is a very productive annual forage crop that is very drouth resistant, and as a spring-sown crop is well adapted to inter-tillage. Experience has also shown that when forage crops, such as alfalfa or sweet clover, are sown in rows and inter-tilled, the yields are more abundant under dry-land conditions of farming than when the crops are sown thickly.

CHAPTER III

MANAGEMENT OF DRY FARMING CROPS

I. FIELD CROPS—GENERAL NATURE—WHEAT—OATS AND BARLEY—RYE—EMMER OR SPELTZ—CORN—SORGHUMS—FLAX—POTATOES—MILLET—ALFALFA—SWEET CLOVER—BROME GRASS—SUDAN GRASS—DAKOTA VETCH. II. PRINCIPLES OF CROP ROTATION. III. LIVE STOCK. IV. THE SUMMER FALLOW.

FIELD CROPS

General Nature — Different kinds of crops require varying amounts of water, and certain species or varieties have greater ability to check transpiration than others. Crop varieties that are low in their moisture requirements are known as drouth resistant varieties and have special value in dry farming. Evaporation is more easily controlled with inter-tilled crops than close-growing crops. These are facts that must be borne in mind in the selection of crops. We must have crops that will produce the maximum amount of dry matter with a minimum amount of water. Their periods of growth must be short, so as to mature before the moisture in the soil from the spring rains is exhausted. Dry farming must be an extensive type of agriculture, while farming on irrigated land is rather an intensive type. Winter wheat, durum wheat, winter rye, emmer, flax, barley, oats, corn, Kafir corn, millet, sweet clover and Sudan grass are the leading dry farming crops, because they are adapted to extensive farming, because they are drouth resistant and mature early.

Wheat — Wheat is the leading dry land crop. Wheat grown on dry land has very high value for milling purposes. Winter wheats are far superior to spring wheats, because the crop takes root in the fall, starts quicker in the spring, roots deeper, and matures earlier. In regions having severe winter with alternating periods of thawing and severe freezing, winter wheats cannot be relied on, and spring wheats must be sown. Durum, or macaroni wheat, is the best type of spring wheat for the dry land farmer. To grow wheat continuously is bad practice for two reasons:

1. The soil becomes infested with organisms causing wheat diseases.
2. In the drier regions sufficient moisture cannot be conserved to produce two or three successive wheat crops.

Since all the small grains have a drying effect on the soil, it is usually best to have the wheat crop follow an inter-tilled crop or a bare summer fallow. It is doubtful whether it pays to grow wheat after an inter-tilled crop where the annual rainfall is less than seventeen inches. With less rainfall it is probably best to summer fallow prior to seeding wheat.

Oats and Barley— It requires more water to mature a crop of oats, pound for pound, than it does a crop of wheat or barley. Oats then is a somewhat expensive crop to raise under semi-arid conditions. It is very likely that much of the energy expended on the oat crop could better be utilized in the growing of other crops which do not require so much moisture. While oats and timothy hay are the standard feeds for livery horses, farmers

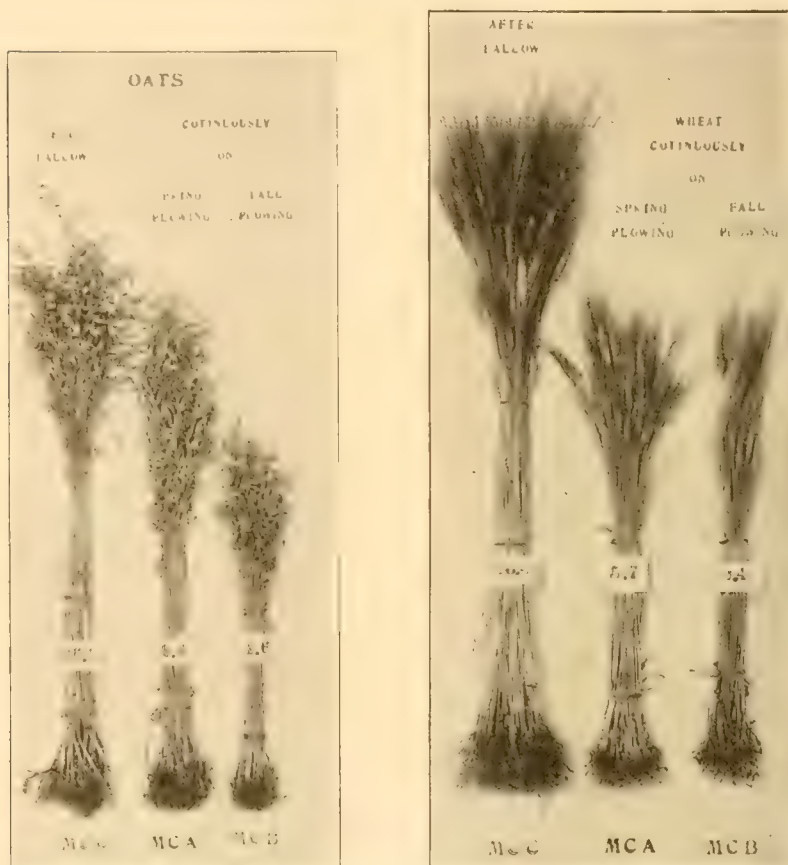

Fig. 5.—Samples of Kubanka wheat and Swedish Select oats from sq. yd. areas grown on Dickinson (North Dakota) Experiment Station co-operative plats. The yields are on the bundles. The fall plowing was done in dry soil. Note the heavy yield upon the fallowed plats.

Courtesy of the North Dakota Experiment Station

will find that they will get very good results by feeding grains other than oats in connection with the coarse feeds. A mixture of speltz and corn, for instance, will be satisfactory during most of the year.

Considerable increase could be secured in the oat crop, if attention were paid to the varieties grown. The Kherson, Sixty Day, and Swedish Select are the best for dry farming.

Barley demands less water than oats, so when the barley crop receives favorable field conditions better comparative results will generally be secured when the moisture is deficient. The early maturing types of awnless barley are considered the most profitable for dry farming.

Rye—Winter rye is one of the surest of dry land crops. It is very hardy, starts quickly in the spring, and matures early—all valuable characteristics for a dry land crop. Rye produces an abundance of straw, and so the stubble adds considerable organic matter to the soil when plowed under. Rye is usually immune to crop diseases.

Emmer or Speltz—Speltz is one of the best spring sown grains available for the dry land farmer. It is quite drouth resistant; it may be



Fig. 6.—Dwarf Blackhull Kafir Corn, grown on Texas Experiment Farm, Dallas, Texas.

sown early and it matures quickly. The yields vary from 15 to 40 bushels per acre according to the soil and the season. Emmer, when ground, is an excellent horse, cattle, or hog feed.

Corn—Corn is one of the best of dry land crops whenever the season is long enough, because of its economical use of water and because of the fact that it readily permits inter-tillage, an operation so necessary to conserving moisture. Corn is a comparatively heavy producing crop and wherever it can be successfully grown it forms a profitable basis for live-stock industries which become a source of profit to the dry land farmer by increasing the value of the grain and forage crops through feeding, and by preventing the rapid exhaustion of plant food from the soil.

Sorghums—Several varieties of sorghum that are very resistant to drouth and hot winds have been introduced into the United States from the semi-arid regions of Asia. Kafir corn and milo maize are being grown in considerable quantity in the semi-arid regions of Texas, Oklahoma, Kansas and Nebraska, and are rapidly being extended into many other semi-arid regions of the western states.

These drouth resistant types of sorghum have the power to check rapid transpiration in dry weather and to be almost dormant during an excessively dry, hot period of mid-summer. With the coming of fall rains and cooler temperatures the crop will resume its growth, and mature its seeds when many other crops would have perished or at least would have been severely injured.

The dry land sorghums require a long, warm growing season of 120 to 140 days. For this reason they are better adapted to the semi-arid regions of the southwestern states than those of the northwestern part of the north central states or the semi-arid regions of the Rocky Mountain states. Several early maturing varieties, however, are finding their way into the northwestern states.

The dry land sorghums are grown largely for their seed which runs in yield from ten to seventy-five bushels per acre, according to the soil and the season. The yields in a semi-arid climate will average higher than for Indian corn. The feeding value of the seed is about the same as corn or barley. Harvesting is very simple, the seed stalks being cut off with a knife thrown into a wagon box, and threshed out in the ordinary grain separator.

The dry land sorghums also make an excellent forage crop. When planted for forage it is customary to sow more seed than when planting is done for a seed crop, and to harvest the crop earlier in the fall.

The sorghums are handled in the field as inter-tilled crops. Thus, in addition to their drouth resistant characteristics, they are of value to the dry land farmer because he may practice surface tillage on land occupied by this crop until mid-summer and thus conserve considerable moisture that would be lost with a thickly planted, spring sown crop.

Flax—Flax makes an excellent dry land crop if the soil is properly prepared and the seeding done at the right time. As a general rule, flax, in a semi-arid climate should be sown on fall plowing, especially so if the land to be used is virgin sod. Successful flax crops are sometimes grown on spring breaking in dry climates, but the risks are far greater than if the crop is sown on fall breaking.

With sod broken in the fall it is possible to disk and prepare a much mellowed seed-bed in the spring than in case of spring breaking. Furthermore, seeding may commence at a much earlier date, and this is a very important factor in flax growing in the semi-arid climate. Very early seeding gives the crop a chance to get rooted and well along toward maturity before the dry spells of mid-summer. Flax may be sown just as early in the spring as wheat or oats without danger to the seedlings, and early seed-

ing on fall breaking should be the invariable rule for the semi-arid climate. When these methods are followed flax is a very dependable crop, but with spring breaking and late spring seeding the crop is risky.

Potatoes—Potatoes are very successfully grown in semi-arid climates even where the rainfall is only twelve to sixteen inches annually, but the mean summer temperatures must be low and the land protected from hot, drying winds. Yields of dry land potatoes as high as 200 bushels per acre are secured on such lands. In the warm, semi-arid regions of the southwestern states, potatoes cannot be grown as successfully without irrigation as in the cooler, more highly elevated, semi-arid regions of the Rocky Mountain states.

The high fertility and the friability of semi-arid soils are very favorable to potato culture. Abundant crops can always be produced if sufficient water can be conserved to insure normal growth. The conservation of moisture is aided, moreover, by the potato crop, in that it is an inter-tilled crop which permits continuous surface cultivation during the late spring and summer months.

The planting of potatoes in "check rows" will permit cultivation in two directions, and is an excellent method for the dry land farmer to use. Such planting gives fewer hills per acre, but the yields will usually run higher because of the more thorough cultivation, the smaller number of vines to cause transpiration of moisture, and the greater amount of moisture that actually becomes available to the crop.

Millet—Millets are of value to the dry land farmer for either forage or grain. They are annual crops that mature very quickly and are drouth resistant. Proso or hog millet yields from fifteen to twenty bushels of grain per acre that is as valuable for feeding live stock as corn or barley. The fine leafed millets such as Hungarian millet will yield from three-fourths to two tons per acre of cured forage.

Millet is commonly used as a thickly sown crop, but it may be sown in rows and inter-tilled with excellent results. In fact, the coarse seed bearing millets produce better when inter-tilled than when sown thickly.

In the semi-arid climate millet should be sown early in the spring and given a chance to make the greater part of its growth before the mid-summer period of heat and drouth. When sown in this manner the crop is very reliable.

Alfalfa—Alfalfa is one of the most suitable forage and hay crops for semi-arid farms. While it has formerly been associated in large part with irrigation, it is becoming evident that the crop may be made particularly adapted to dry farming conditions. The root system of the alfalfa plant plainly indicates its adaptation to dry regions. It is adaptable to great extremes of moisture supply if the soil be given good drainage. While producing wonderful yields with an abundance of water, it will make a good showing under a rainfall of fifteen inches, provided that it be given proper culture.

Its water requirement is probably about the same as that of clover, thus being higher than the water requirement of wheat. Its extensive root system, when given proper opportunity for development, together with its long seasonal growth, due to its perennial habit, offsets in considerable measure, its comparatively high water requirements.

Alfalfa is commonly given a thick seeding. The method is allowable if the roots go down to permanently moist soil. If the alfalfa depends upon the rains for its moisture supply, and it must under dry farming conditions, thick seeding will not produce good results. Where moisture is deficient, the alfalfa plant must be allowed to develop an extensive root system and this is possible only where thin seeding is practiced.

For the best results in the drier areas it may be advisable to plant the alfalfa in rows so that it can be cultivated. This statement certainly applies where the seed crop is to be made prominent. If the alfalfa seeding is thin enough so that each plant may develop a good root system and so develop more or less of an individuality, and further, if the alfalfa stand be thin and be given a reasonable amount of cultivation to prevent excessive evaporation, there is no question but what the alfalfa will make the best possible use of the water that falls.

In semi-arid climates special care should be used to obtain seed of the hardy varieties of alfalfa such as Grimm, Liscomb, and Variegated. The United States Department of Agriculture and the various Agricultural Experiment Stations are constantly working to discover or breed new hardy varieties of alfalfa, and the dry land farmer will do well to seek out these varieties and make use of them.

Sweet Clover — Although sweet clover demands a great deal of attention, it is a valuable forage, pasture, and seed crop for dry farming. It is very hardy and drouth resistant and thrives on sandy land, hard soil, or light soil, where other forage crops are unproductive. On good soil it yields more abundantly than alfalfa without irrigation.

Sweet clover hay is not always palatable to stock that has been accustomed to alfalfa, clover, or other kind of forage. Occasionally it is necessary to starve stock to it but this is rarely the case if the crop is cut early before it gets coarse and woody. Its feeding value is nearly as high as that of alfalfa.

Sweet clover is a biennial plant completing its life cycle in two years. Reseeding is therefore necessary every two years. It should be sown in the fall or early spring in dry climates. Fall seeding is preferable if the soil is moist.

Sweet clover can be handled as an inter-tilled crop, if desired, and with summer cultivation may be considered a very sure crop.

The seed of sweet clover is in such great demand that seed growing is a most profitable enterprise for the dry land farmer.

Brome Grass — Brome grass is a hardy, perennial drouth resistant grass that has considerable value to the dry land farmer for permanent

pasture and meadow. In fact, brome grass and alfalfa are the only perennial forage and pasture crops available to the dry land farmer.

Once brome grass has become well established it will survive protracted drouth and come out fresh and green with the return of rain. It provides good pasture very early in the spring and late in the fall.

Brome grass may be sown in rows and inter-tilled if desired. The seed is always in good demand and seed crops from inter-tilled brome grass are a source of good profit.

Sudan Grass—Sudan grass is a newly introduced forage crop brought to the United States from Africa. It is an annual plant closely related to the sorghums, and must be seeded every year. It is extremely quick growing and like the sorghums has the ability to remain semi-dormant during a period of drouth.

Sudan grass thrives best in a warm climate, and when supplied with sufficient moisture will produce from two to four cuttings in one season. In the United States it is best adapted to the central region of the Great Plain, that is, Texas, western Oklahoma, western Kansas, western Nebraska and central South Dakota. There the summers are sufficiently warm and long enough to mature from one to two cuttings, and these sections need a drouth resistant forage crop. Sudan grass fills this need. It produces more abundantly than the forage millets, and the hay is more nutritious.

In the western states the temperatures are commonly too cool for Sudan grass to produce abundantly. In the arid regions of the southwestern states Sudan grass will produce large yields under irrigation.

In semi-arid regions the best crops of Sudan grass are secured by sowing in rows 36 inches to 42 inches apart, and thus providing for inter-tillage during the summer. The seed cannot be sown as early as wheat, oats, or millet, but should be sown about corn planting time in a warm seed-bed. Warm temperatures are required to give a strong uniform germination.

Dakota Vetch—Dakota vetch is a quick growing, annual legume of considerable value to the dry land farmer as a forage crop or a green manure crop. The hay is very nutritious and palatable. Yields vary from one-half ton to two tons per acre, according to soil and climate conditions. The crop is sown very early in the spring with the grain drill and is harvested early in July in a normal season. Dakota vetch will thrive in a great variety of climates, and may be profitably grown in any of the semi-arid regions of the central or western states.

PRINCIPLES OF CROP ROTATION

No effort will be made in our limited space to outline crop rotation plans but it may be well to suggest a few of the important principles. The live-stock industry and the crops associated with it should form a very considerable portion of dry farming, vastly more so than they do at the present time. In planning the rotation and the system of farming, it should always be borne in mind that the foundation of successful farming is successful

crop production; that the basis of successful crop production is the soil, and that in dry farming regions the chief limiting factor in crop production is the water supply of the soil. Therefore, some part of any successful crop rotation which includes the small grains, must have for its object, the conservation of moisture at some period of the rotation.

In other words, this means that a rotation containing small grains must also contain an inter-tilled crop, such as corn, or Kafir corn which requires less moisture than fell during the growing season, so that, at the time of harvesting such a crop, there will be a greater quantity of moisture in the soil than there was at sowing time.

If, however, the moisture is insufficient both for growing a crop and for conserving an amount sufficient to practically insure the succeeding crop, then any such inter-tilled crop, as the corn crop, must be put in the same class as a grain crop. From the standpoint of the results secured it must be considered a moisture dissipating crop rather than a moisture conserving crop. Where this is the case it will evidently be necessary to utilize the clean summer fallow in place of the inter-tilled crop.

Where money crops are made a feature of any system of farming, there is a constant tendency for humus to be lost from the soil. This loss has an injurious effect upon the physical properties of the soil and often in a marked degree. After having lost a considerable part of its humus a soil is more apt to "blow." Furthermore, such a soil is not so easily tilled when wet and is more apt to run together or puddle. The water holding capacity of the soil is decreased by the loss of humus, as humus is a valuable storage agent of water. With these facts in mind, it is of the greatest importance that any system of rotation which has for its main feature the production of grain crops should look towards the retention of the humus in the soil. The desired results may be secured (1) by the application of barnyard manure; (2) by the plowing under of green manure crops, such as winter rye, Dakota vetch, or sweet clover; (3) by the inclusion of pasture and meadow crops in the rotation—the rotting of the grass roots or of the legume roots sufficing to render the land more like the virgin prairie.

The inclusion of legumes in the rotation will maintain the supply of available nitrogen in the soil, as well as add supplies of humus. Alfalfa, sweet clover and Dakota vetch are the three most valuable legumes for the dry land farmer.

Certain plant diseases, affecting especially the small grains, tend to accumulate in the soil. According to Prof. Bolley, of the North Dakota College of Agriculture, the rotation of crops, introducing an inter-tilled crop, grasses or legumes, holds such diseases in check. Crop rotation, therefore, is a benefit from this standpoint.

LIVE STOCK

While often it is possible to carry on farming successfully upon new lands independent from the growing of live stock, provided moisture is

sufficient, yet it is extremely doubtful if such a method could be continued indefinitely.

The presence of live stock upon the farm introduces a stability to the agriculture which is not secured when the efforts of the farmer are directed along the lines of mere crop production. A man with dairy cows, for instance, has established a system which regulates and governs his income. It may be that for a period of fifteen years upon new lands the income of the dairy farmer would be no greater than the income of the man raising money crops, provided the one raising the crops followed sane and conservative methods.

Even admitting the truth of this we find that such a result does not work out in practice. After a good season, the farmer is willing to increase his hazards that the season following will be equally as good. The keeping of the dairy cow enforces and makes necessary a safe and more certain method of farming.

In the long run the problem of soil fertility becomes a prominent one. While the quality and fertility of the soil may be retained by growing legumes and the application of mineral manures, yet it is doubtful if such a method is economical. The fodder necessarily produced upon the farm in the rotations can be disposed of economically only through live stock, as a general rule.

THE SUMMER FALLOW

Frequent reference has been made to the summer fallow. The summer fallow has for its object the storing of one season's rainfall for the use of the crop the next season. In order to accomplish this object the soil must be loose and permeable to a considerable depth to soak up the rainfall, and secondly, the dirt mulch must be maintained to prevent evaporation. Neglecting to provide the surface mulch at any time may cause more moisture to evaporate in a few hot days than would fall during the whole season. After rains, the field must be worked with the disc or the peg-tooth harrow as soon as it is dry enough. Often weeds are allowed to grow on the land supposed to be in fallow. Weeds or sage brush will use just as much water as a crop would, and perhaps even more than the corn crop, because no dirt mulch is being maintained. Weeds must be destroyed.

Experience has shown that, where the annual rainfall is twelve to fifteen inches a bare fallow every other year is necessary. Where it is fifteen to twenty inches, fallowing is not necessary, but the principles and practices of dry farming must be applied to insure a crop. It has been found at the Montana Experiment Station that a soil containing 7.7 per cent of moisture in the fall had 11.5 per cent in the spring and after proper fallowing through the summer, it still contained 11 per cent. The theory works out in practice, but doing summer fallowing in a slipshod way is not doing it at all and is bound to cause crop failure the next season. Widtsoe says that with care in handling an ordinary loam soil, 75% of a season's rainfall can be stored up in the soil for the use of the next year's crop.

TREES AND SHRUBS ON THE DRY LAND FARM

Settlers in the semi-arid West undoubtedly regret the absence of the wooded knolls of the humid regions. Although the growing of any but western grasses for lawn purposes is impossible without irrigation, certain trees and shrubs can be grown. The protection which trees offer against the glaring sun is an irrefutable argument for a hedge of trees. In the winter they serve as a wind-break. There are those who claim that the planting of trees in large numbers upon the plains would greatly modify the climate of these regions, that rainfall would be increased, and that drying winds would be less frequent. Be that as it may, a few shade trees and a fruit garden are certainly desirable on every farm.

The plans should be made first. Then the ground should be left in bare fallow at least one year. Healthy, vigorous plants, adapted to the locality where they are to be planted must be secured. Trees one or two years old are best. The plants should be set out as early in the spring as possible. For directions for planting see Book IV, "The Garden and the Orchard." Either a dust mulch or a straw mulch is an absolute necessity in these semi-arid sections. The orchard should have a wind-break. The best trees for the wind break are the Canadian poplar, native cottonwood, box elder, golden Russian willow, green ash, white elm, and Russian olive. The common lilac succeeds very well in trying locations. Fruit trees and bush fruits must be selected according to the climate to which they are adapted. For Montana conditions and sections where similar climatic conditions prevail the following varieties of fruit promise to be of most value.

Currants: Cherry, Red Dutch, White Grape.

Gooseberries: Houghton, Downing, Champion.

Red raspberries: Cuthbert, Ruby.

Plums: De Soto, Forest Garden, Hawkeye, Wolf.

Apples: Yellow Transparent, Duchess, Wealthy, Gideon, Northwestern Greening, Okabena.

Crab apples: Hyslop, Whitney.

Pears: A few Flemish Beauty and Bartlett trees may be planted for a trial.

CHAPTER IV

DRY FARMING MACHINERY

I. PLOWS. II. HARROWS. III. WEEDERS. IV. CULTIVATORS. V. PACKERS. VI. SEEDERS—TABLE NO. 4—AMOUNT AND DEPTH OF SEEDING FOR DRY LAND CROPS. VII. HARVESTERS.

Previous reference has been made to the types of machinery best adapted for the conservation of moisture. It should not be forgotten that where special attention must be given to the conservation of moisture, extra crop cost is entailed. Machinery therefore should be purchased and used on the basis of its making a profit for the money expended. It may be said at once that the plow, the disk harrow, the peg tooth harrow and the corn cultivator are the really essential tools needed to conserve moisture and to produce a good seed-bed.

One should study the matter carefully in buying additional tools, and especially is this true where the outlay can be illly afforded. It is very important that the tools that are owned be kept in good condition. A few general purpose tools kept in good condition, combined with a knowledge of their proper use, will do vastly more efficient work than double that number of specialized tools without any idea as to their efficient use.

Plows—Breaking the virgin sod is best done with the mouldboard breaking plow which will cut and invert the sod more smoothly than the mouldboard stubble plow or the disk plow. In the plowing of stubble ground the disk plow can be used on drier soil than the mouldboard plow. As a rule, the sulky mouldboard plow, with an abrupt curvature to crumble the soil, is the best plow to use for stubble ground. The use of the subsoil plow has been discussed under subsoiling.

Harrows—The disk harrow is the most important of the many pulverizing implements. It consists of several disks running side by side upon an axle. The disks can be set at an angle to the line of traction, thus turning the soil as well as pulverizing it.

Disk diameters of 18 to 20 inches are preferable to disk diameters of 14 inches on account of lighter craft. In spring plowing, the disk should follow directly after the plow. If land is plowed in the fall and left in the rough, as it should be, disking should be the first operation in the spring. The disk harrow is used for disking stubble land after harvest; for the tillage of fallow land throughout the summer; and for keeping down weeds.

The peg-tooth harrow follows the disk in preparing the dust mulch and the seed-bed. The harrow should have rectangular teeth and be provided with levers. It is also used in maintaining the mulch after seeding. Corn



Fig. 7.—The Disk Harrow. Note the pan in which weights can be placed if necessary. The two gangs can be set at different angles for side hill disking.

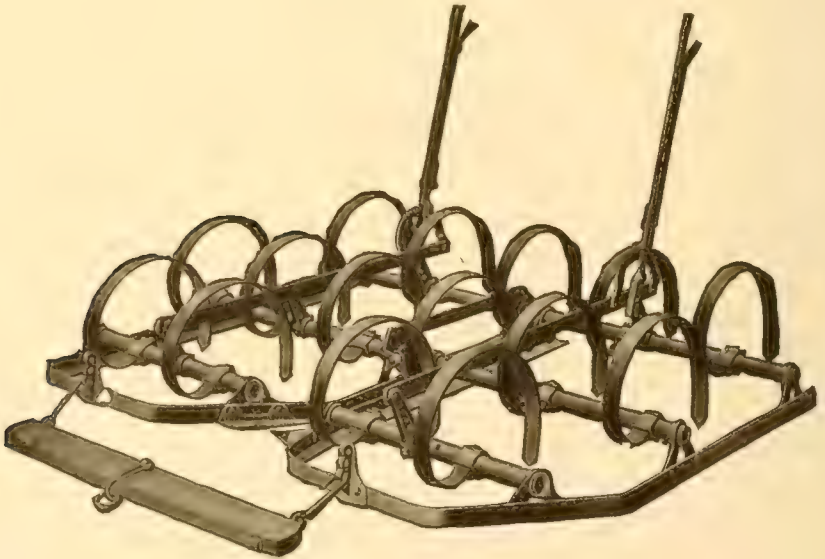

Fig. 8.—Spring Tooth Harrow.

and the small grains should be harrowed until they are four inches high. If the grain is too thick the teeth should be set straight to thin it out. If it is too thin, harrowing with the teeth set back, will cause the plants to stool out more. The cutting edge of the teeth should be angular.

The spring-tooth harrow is a very useful type of harrow for use on heavy soils; its functions being much the same as the disk harrow. It is sometimes used for stirring up old alfalfa fields.

Weeders — Weeders are used for keeping down small weeds, and for preserving the surface mulch in growing grain. The weeder is also useful for harrowing in small seeds such as alfalfa or sweet clover that have been broadcasted.

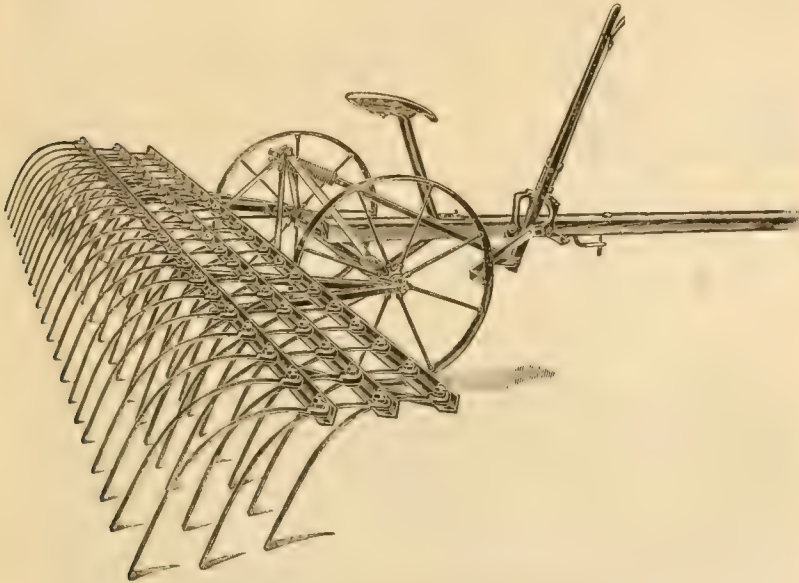

Fig. 9.—Weeder for Harrowing Small Grains.

Weeders are preferable to harrows for small grain cultivation unless the soil is hard and packed. Their use can be continued until the grain is four to five inches high.

Cultivators — Cultivators are used for the intertillage of corn, Kafir corn, potatoes, or other crops planted in rows. Sulky cultivators perform more thorough work than the walking cultivators and at less cost per acre.

Disks, spring teeth, shovels, or hoes may be used and attached to these cultivators. On large farms the double row sulky cultivators drawn by either three or four horses is the best type of cultivator because of the rapidity with which work may be done.

Packers — There are several kinds of packers, the most important types being the Campbell sub-surface packer, the Dunham rod packer, and the corrugated steel or concrete roller. Most of the steel corrugated rollers are not heavy enough and weights must be added onto the frame. A good

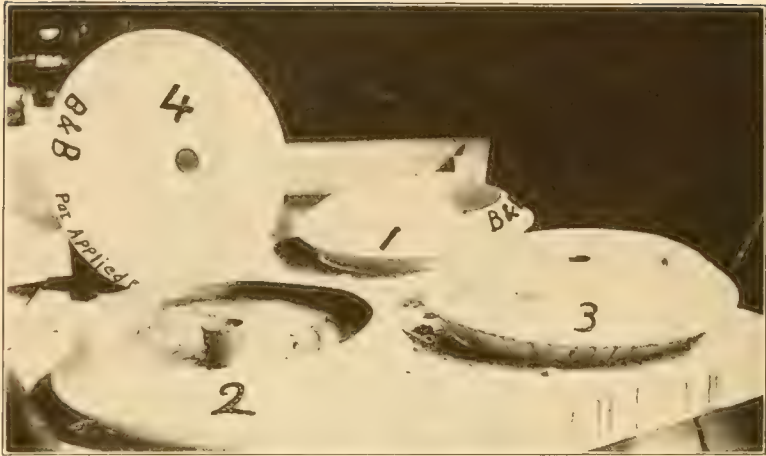

Fig. 10.—This cut shows the method of manufacturing a concrete corrugated roller by means of the patent steel rim. No. 1 is a rim laid upon the floor, ready to be filled. No. 2 shows hub, reinforcement, and part of the cement mixture in place. No. 3 shows rim just filled with cement; water is seen dripping over the side of the rim. No. 4 is the wheel after it has set for 45 days. It is now ready for use.

Courtesy of the Montana Experiment Station

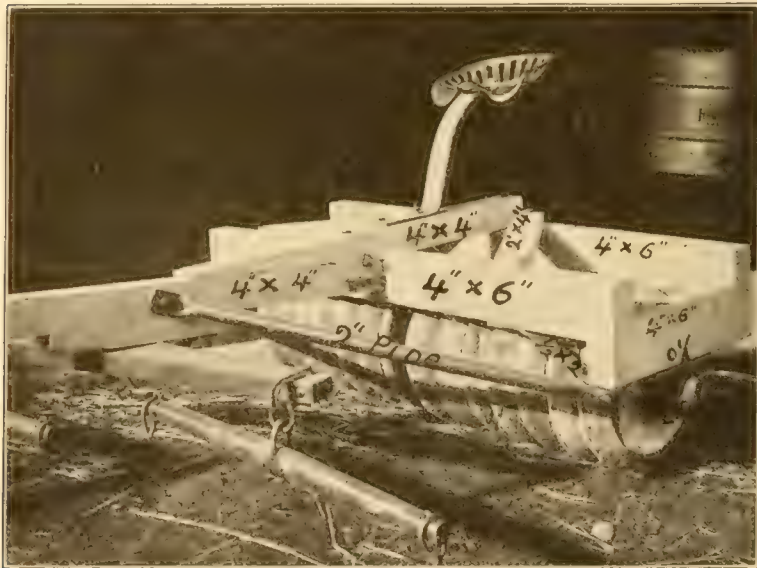

Fig. 11.—A concrete corrugated roller complete. All parts made of soft wood except the tongue. If the tongue is made of soft pine it should be 4 by 6 in place of 4 by 4.

Courtesy of the Montana Experiment Station.

corrugated roller can be made out of concrete and gas pipe. The concrete mixture is one part of cement to three parts of clean, sharp sand. The moulding is explained in the notes accompanying Fig. 10. The hubs are made of gas pipe; a 2-inch gas pipe requires a $1\frac{15}{16}$ -inch steel rod for an axle. The concrete wheel is 19 inches in diameter and $\frac{1}{4}$ inches thick. When assembled this gives a roller of sufficient weight to pack the soil well.

The roller must be followed at once by the harrow to re-establish the dirt mulch.

When a sub-surface packer or an ordinary disk harrow with the disks set straight is used, harrowing is unnecessary, for the dirt mulch is never destroyed.

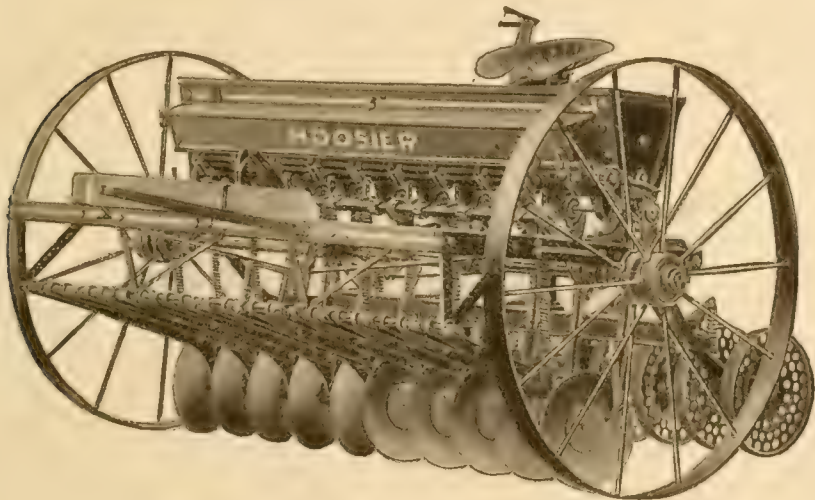

Fig. 12.—Disk Drill with Press Wheel Attachment.

The planker or float is a home-made clod crusher useful in smoothing out new breaking in order to prevent the wind from getting into the sod and quickly evaporating the moisture. The dry land farmer has little use for a planker if the plowing and disking are done at the proper time and under proper conditions. The planker is occasionally of value to smooth and fine the surface soil of a seed-bed for crops like alfalfa and sweet clover.

Seeders—The single disk drill is the most popular type of drill among dry land farmers. Broadcasting is very poor seeding practice in a semi-arid climate. Whether the shoe or disk drill is used, the seed must be properly covered. The work of covering the seed is usually done by chains, but the advisability of packing the soil about the seed has led to a wide use of the drill press seeder. The disk is followed by a light wheel which presses the soil into the furrow about the seed. This accomplishes the same thing that rolling would. The corn planter works on the same

principle as the drill press seeder. The soil should be harrowed soon after seeding because this packing somewhat impairs the efficiency of the dirt mulch.

Depth and rate of seeding should vary somewhat according to local climate conditions and condition of the soil at the time of seeding. A moist soil or a fertile soil can be seeded thicker than a dry or an infertile soil. Small seeds like alfalfa cannot be planted as deep as corn. As a general rule, grains and forage crops are sown from one-half to two-thirds as thick in the semi-arid as in the humid region and about again as deep.

The accompanying table shows the standard amounts of seed per acre for common dry land crops, also the general rules as to depth of planting.

TABLE No. 4
AMOUNT AND DEPTH OF SEEDING FOR DRY-LAND CROPS

Crops	Amount of Seed per acre	Depth to plant	Best Machine to Use
Alfalfa thickly sown	6-8 pounds	1-2 inches	Grass seeding attachment on grain drill.
Alfalfa in rows	3-4 pounds	1-2 inches	Grass seeding attachment on grain drill.
Barley	5-6 pecks	3-4 inches	Grain drill.
Brome grass thickly sown	6-8 pounds	2 inches	Brome grass seeder with seed grain in drill; or hand sow and harrow in.
Brome grass in rows	3-4 pounds	2 inches	Brome grass seeder with seed grain in drill; or hand sow and harrow in
Corn	6-8 pounds	3 inches	Check row corn planter
Emmer or speltz	6-8 pecks	3-4 inches	Grain drill.
Flax	1-2 pecks	1½-2 inches	Grain drill.
Millet sown in rows	1 peck	1½-2 inches	Grain drill
Millet forage thickly sown	1-2 pecks	1½-2 inches	Grain drill
Oats	6-8 pecks	3-4 inches	Grain drill
Potatoes	8-10 bushels	4-5 inches	Potato planter or by hand.
Rye, winter	3-4 pecks	3-4 inches	Grain drill.
Sorghum or Kafir corn in rows.	3-6 pounds	1½-2 inches	Corn planter with sorghum plates.
Sudan grass in rows	4-6 pounds	1½-2 inches	Grain drill.
Sweet clover thickly sown	10-12 pounds	1-2 inches	Grass seeding attachment on grain drill.
Sweet clover in rows	4-6 pounds	1-2 inches	Grass seeding attachment on grain drill.
Vetch Dakota, thickly sown	2 pecks	2-3 inches	Grain drill.
Wheat, winter	3-4 pecks	3 inches	Grain drill.
Wheat, durum	3-4 pecks	3 inches	Grain drill.

The general rule as to depth is: Plant as deeply as is safe to insure germination. Seeds can be safely planted deeper on sandy than on heavy soils; deeper on dry than on moist soils; and deeper in warm than in cool weather. Small grains are planted from three to four inches deep in the semi-arid regions. The listing of corn puts the seed in very deep, thus causing deep rooting which assists the crop to withstand drouth in dry years. However, the furrows made by the lister are not immediately closed up, and, if heavy rains come, water will collect in the furrows and retard germination and early growth. Listing is considered best for regions where soil is subject to blowing, for, where the corn or sorghum seedlings are in the bottom of the lister furrow they are protected from the cutting action of wind-driven soil particles.

Harvesters — Harvesting crops in the semi-arid region is done in much the same manner as elsewhere but on a larger scale. The machinery is usually similar although the very dry harvest season permits the use of the header if desired. On account of the dry season, harvesting is not attended with so much uncertainty as in the humid regions.

CHAPTER V

HINTS TO THE DRY LAND FARMER

I. AMOUNT OF RAINFALL—TYPE OF SOILS—SIZE OF FARM. II. TEN COMMANDMENTS OF DRY FARMING.

A few suggestions to the man who is thinking of going into dry farming, especially if he is from the humid region, should be valuable.

Necessary Amount of Rainfall — On no account should he attempt to raise crops by dry farming methods where the annual rainfall is less than ten inches. Furthermore, he should bear in mind that, due to greater evaporation, fifteen inches of rainfall in Texas is worth a great deal less than fifteen inches in Montana. The per cent of total precipitation that falls in March, April, May, and June is also an item to be taken into consideration.

Importance of the Proper Type of Soil — He must recollect that he farms with ten feet of soil instead of ten inches and so he must examine the subsoil. A gravelly subsoil, that was not noticed by a certain ranchman, when he planted his orchard caused its death after five years of apparently healthy growth. A soil with gravel or sand seams is a "faulty" soil. These are indicated by abnormal or undeveloped trees, by observing the material brought up by ants and burrowing animals, by observing railroad cuts or by boring or digging to a depth of five or six feet. There should be no clay, gravel or sand seams, because they check the movement of water. The water table should be at least ten or fifteen feet below the surface, for alfalfa roots will penetrate to that depth, and alfalfa cannot endure wet feet.

Sandy loams, loams, and silt loams are best adapted to dry farming. The soil must not be too loose nor too compact. A hard pan is an undesirable but curable condition.

The soil must be deep (over fifteen feet) or there is no large storage reservoir for the water so essential to the crop.

The presence of native legumes (pod bearing plants) indicates enough lime in the soil and a depth of soil that would warrant dry farming, rainfall being sufficient. A good healthy growth of sage-brush assures the success of dry farming.

There should be humus in the soil for it increases the water holding capacity of the soil, makes it workable and friable, adds to the fertility, and checks blowing by the winds.

Size of the Farm — The best size of farm to be operated depends on the industry of the owner, the size of his family, the soil, the climate, the kind of crops to be grown, the location, and the amount of live stock he plans to keep.

The usual size of irrigated farms is from 40 to 160 acres. But the dry land farmer, on account of the fact that part of his land may lie in bare fallow and the rest is but thinly seeded, should have 160 to 610 acres in order to make a comfortable living.

TEN COMMANDMENTS OF DRY FARMING—Palmer

1. **Plow Deep**—It lets any rain into the soil easily, and a heavy one without any run-off. It provides more feeding space for the roots and makes more plant food available. Fall plowing is preferable to spring

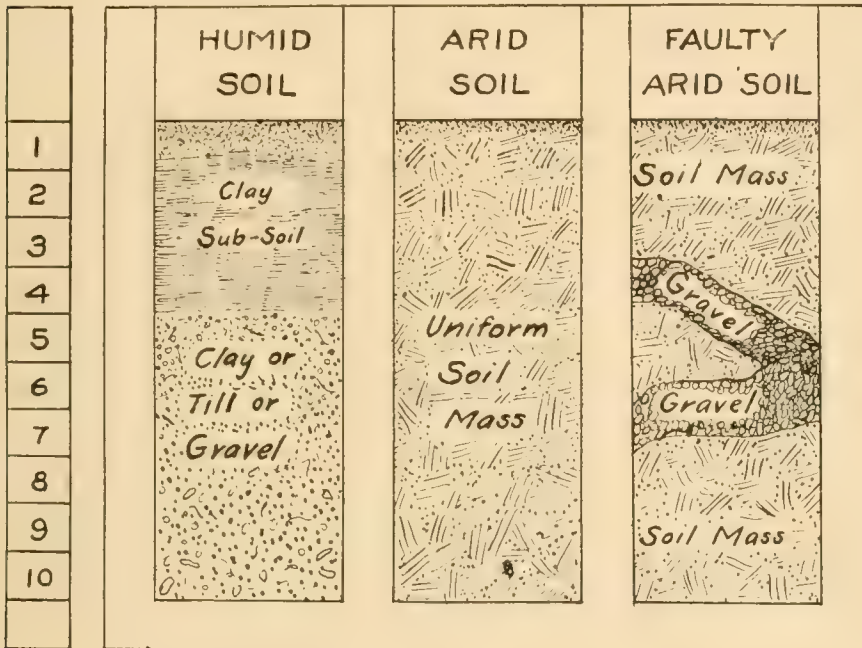

Fig. 13.—Soils in Humid and Arid Regions. Note the absence of a clay sub-soil in the arid soil; the uniform mass may extend to a depth of much more than ten feet. The "faulty" arid soil is undesirable on account of gravel and sand seams. (Numbers at the left represent depth in feet.)

plowing. Land left in the rough furrow over winter takes in water more readily than harrowed land.

2. **Keep the Surface Soil Loose**—It checks evaporation. Harrow small grains and corn until they are four inches high or use the weeder. Disk and harrow as early in the spring as possible. Cultivate corn as long as possible. Disk the stubble as soon as crop is removed. *Always conserve moisture as though a year of drouth were coming.*

3. **Cultivate Level**—A ridged soil surface dries out faster and loses more water than a level soil surface. Ridged land reduces the feeding area available to the plant.

4. **Summer Fallow When Rainfall Is Less Than Fifteen Inches.**—

A corn crop prepares the soil for a grain crop as well as the bare fallow. The fallow must be disked and harrowed throughout the summer.

5. **Add Organic Matter to the Soil**—It holds moisture and plant food, improves the mechanical condition of the soil, and helps make plant food available. It checks the drifting, blowing and washing of soil. Stable manure is the best form of organic matter. Plow weeds under when green.

Commercial fertilizers should be avoided in dry farming, because they are expensive and do not add humus to the soil. Plow under legumes to increase the humus and nitrogen in the soil.

6. **Keep Down the Weeds**—Weeds use up moisture. Weeds use up plant food. Weeds crowd the plants and shade the crops. Weeds make it difficult for the plant to grow. Weeds make it hard to work the land properly.

7. **Grow Early Maturing Crops** and such crops as make economic use of the water.

Growing conditions are best in early spring; accordingly grow winter grains if possible. Some varieties are more drouth-resistant than others; sow them. Sow only by the drill method, and plant deeply—3 to 4 inches for grain.

8. **Grow Corn or Other Cultivated Crops Every Three to Five Years**—The cultivation given corn saves moisture, kills weeds, and checks plant diseases. Corn prepares the land well for a grain crop. Corn produces fine stock food, both grain and fodder. Corn produces more per acre than other crops. Do not hill the corn, as this wastes the moisture.

9. **Grow Legume Crops Every Few Years**—They add nitrogen and organic matter to the soil, and check weeds and plant diseases. They make valuable hay to be fed with corn. Legume seed crops are very valuable.

10. **Keep Live Stock**—The most profitable way of marketing grain and fodder is through stock. They produce manure which is very necessary to the soil. They bring about prosperity.

PART III — IRRIGATION

CHAPTER I

I. THE CAREY ACT. II. THE RECLAMATION ACT. III. WATER RIGHTS. IV. VALUE OF WATER.

INTRODUCTION

Irrigation projects in the United States are fast being completed by the best irrigation engineers of the country. In 1910 a total of 31,112,110 acres of land of the United States were included in all irrigation projects of which 19,335,711 acres were irrigable and 13,739,499 acres were actually in crops. Three and one-half per cent of this acreage was irrigated by pumped water, and the balance from streams and reservoirs.

The Carey Act—Early irrigation in the United States was carried on almost exclusively by means of water diverted from a stream or natural lake. Little garden spots of irrigated land appeared here and there over the arid region, but very little progress was being made in this manner until the "Carey Act" was passed. This put irrigation on a firm basis and encouraged the investment of capital in irrigation enterprises. The essential features of this act are: The state received 1,000,000 acres of the public domain to be parceled out. The state could install the irrigation system itself or sublet the work to contractors. The land had to be occupied six months after the water was available, and at least 20 acres of each 160 acres reclaimed had to be under cultivation within two years after the occupation of the land. To avoid speculation a further proviso was made that the land cannot be sold in tracts larger than 160 nor smaller than 40 acres. The water rights must be purchased from the party who installs the irrigation system.

The Reclamation Act—Irrigation prospered well under the "Carey Act," but it was thought that a further stimulus was needed. So in June, 1902, the Reclamation Act was passed. It permits setting aside the proceeds from the sale of the public land for the purpose of surveying, constructing and maintaining irrigation works for the storage and diversion of water for use on arid land. The Reclamation Service has charge of the distribution of water until a Water Users' Association can be formed. Projects of the Reclamation Service already completed or under construction contemplate the irrigation of 3,401,000 acres of land, and include such much discussed projects as the Shoshone (Wyoming), Yakima (Washington), Milk River (Montana) and twenty-six others.

Water Rights—In the early days of American irrigation, when streams were running to waste, the farmer diverted all the water he needed and even more, oftentimes to the detriment of his crops. In recent years so

many irrigation projects have been installed, that water is in great demand, and it has become a criminal offense in most states for the water user, during periods of water shortage, to change the head-gates which regulate the amount of water each water user may receive, after they have once been adjusted by the water commissioner.

The men who first appropriate the waters of a stream for irrigating land along its banks have "prior rights" over those who appropriate water at later dates. A prior right entitles the owner to a constant use of the number of miner's inches or cubic feet of water called for in his title as against all subsequent locaters along the stream.

Primary water rights (those that a stream can always satisfy) have in most cases been adjudicated by the courts as first, second, third, etc., in accordance with the size of the stream. Primary rights are now prizes that are well nigh unobtainable. However, appropriated flood water rights, or secondary rights, are as valuable to an intelligent irrigator as prior rights would be. In fact, the man who irrigates once during flood water season, may raise better crops than his neighbor who has prior rights and selfishly intending to use them, keeps his fields too wet. Legislation in regard to water rights and the diverting of streams must be considered in every individual state. It is best to confer with lawyers who are specialists in irrigation law or with the irrigation officers of the state before investing in irrigable land, in order to ascertain the real value of the water rights appurtenant to the land.

In Government Reclamation projects the irrigation farmer is likely to receive more equitable treatment than under private systems. Co-operative, individual and partnership enterprises comprise 71.5 per cent of the total area of irrigation projects in the United States, but it is likely that, in the future, water distribution will be carried on to a greater extent by the Federal Government.

If the irrigator is purchasing water from an irrigation company, he buys and pays for so many inches of water and the company is bound by contract to deliver it to his ditch when he wants it. The farmer has nothing to do with rights and priority, the company tends to that end of it. This plan is usually followed when the water has to be pumped, the irrigation company operating the pumping plant.

Value of Water—On account of the ever growing demand for water in irrigated regions it becomes necessary for the irrigator to increase the duty of water, that is to say, in the future he must accomplish with a relatively small amount of water the same thing that he has been doing in the past with all the water he could use.

The losses of water which produce a low duty are:

1. Losses which occur by seepage and evaporation from the conveying canals and ditches.
2. Loss on the farm by deep percolation into the soil.
3. Loss of soil moisture by evaporation.

4. Loss by surface run-off or waste at the ends of fields or furrows.

Furthermore, as the demand for water goes up the price increases, and the irrigator should know how much water he is using as much as the manufacturer needs to know how much electric current he is using. Where water is most needed for irrigation it is generally most valuable, and if the payment for this water is based on measurements of the volume delivered to the irrigator the water will be used with care and skill, which will make the duty high. On the other hand, where water is plentiful and cheap, and sold on a flat charge per acre, independently of the volume used, or where the irrigator or irrigation company is protected by a water right which entitles him to an excess of water to the detriment of others, there is no incentive for economy in the use of water, crude and wasteful methods of irrigation prevail, and the duty is low.

The importance of obtaining the highest duty of water is apparent when it is realized that the available water supply, when fully developed, will only serve a very small part of the total area of land adapted to irrigation in the arid and semi-arid region, and that wasteful irrigation has been the main cause of over ten per cent of the irrigated lands becoming unfit for crop production through water-logging and the accumulation of alkali salts in the surface soil.

CHAPTER II

SOURCES OF IRRIGATION WATER

I. STREAMS. II. SPRINGS. III. STORAGE RESERVOIRS. IV. PUMPING PLANTS. V. PUMPING FROM WELLS. VI. MOTIVE POWER.

Streams—The sources of irrigation water are streams, storage reservoirs, springs and wells. Water may be drawn from streams by means of canals and can be carried with a fall of four feet to the mile for a considerable distance. Most western streams have at least twenty-five feet of fall to the mile and it is, therefore, evident that canals with a fall of four foot to the mile can be used for taking water out of the stream and carrying it on to bench lands down stream that are considerably above the level of the stream.

Streams to be useful for irrigation must have a sufficient flow at the time when water is needed. The water must be relatively pure; that is, it should not carry great quantities of alkali or other injurious material.

The water should be available during the irrigation season. A great many people are under the impression that they have good supplies of irrigation water when, as a matter of fact, during the irrigation season they have little or no available water.

The available quantity of water should be sufficiently large to enable the irrigator to cover the ground quickly. By the use of a large amount for a short time all the land receives approximately the same quantity of water, whereas with a small amount the parts of a field near the main ditches may receive too much water before the more distant parts of the field can be properly covered.

The water should not only be relatively pure, available at the right time, and available in sufficient quantities, but the supply should be reliable. A great many of our smaller irrigation systems afford large quantities of fairly pure water when in working order, but because of poor management, poor construction, or unexpected weather conditions, these ditches may wash out and become useless at the critical periods when water is most needed.

Springs—A private supply from some large spring affords a good source of water, provided the water is not strongly alkaline or otherwise injurious to vegetation. In case the spring does not afford a sufficiently large head of water to enable the irrigator to do good work, it often pays to establish a small reservoir in which one or more day's run of the spring may be stored. Then from this reservoir a large head is drawn off and used by the irrigator. Such a reservoir should have a clay bottom and the sides or dikes should be firmly packed to avoid unnecessary losses

from seepage. The outlet should be controlled by a steel headgate set in concrete.

Storage Reservoirs—In some parts of the country companies are formed for the purpose of building storage reservoirs. These reservoirs are filled by flood waters, by small springs or streams, or during the winter by water from streams which have already been appropriated during the irrigation season. These systems are, as a rule, very reliable if the engineering is good, but in case poorly constructed dams, embankments, headgates, etc., are used, the rights are sometimes of little value.

As in the cases previously mentioned, the prospective buyer should investigate the source of supply and the reliability of the system before purchasing stock or water rights.

Pumping Plants—It often happens that a good supply of water is obtainable, but the water is below the level of the land to be irrigated. In case the lift is not too great, it is often advisable to raise the water to the land by means of a pump. In localities where power can be obtained cheaply, water is now being raised as much as 50 feet for the irrigation of meadows, pastures, grains and sugar beets. In the case of gardens and orchards, which produce large profits per acre, it is often found profitable to raise water as much as 100 to 120 feet. The price of power, the kind of land to be irrigated, and the crop to be raised, are factors which determine whether or not pumping for irrigation is profitable.

In case the water is to be pumped from a stream, it is usually advisable to cut an intake from the side of the stream to a point in the adjoining field, where there is a good foundation and no danger of washouts. The water is brought from the stream by the intake ditch to a sink or basin in which the pump is installed. By the use of a submerged centrifugal pump, all difficulties such as priming and stopping suction leaks are eliminated. In the case of small pumping plants, it is practicable to equip a water wheel, an electric motor or an oil engine with large oil cups or automatic oilers, so that the plant may be allowed to run five or six hours without attention. This enables one man to operate the plant and, at the same time, to do the irrigation on the nearby fields. A weir should be located in the main ditch, near the pumping plant, so that the operator may keep a check on the amount of water which is being lifted. An automatic alarm operated by a float in the weir box may be so made as to notify the irrigator by signal or by electric gong as soon as the pump is not throwing the right amount of water. A combination of the weir and automatic alarm saves much time and expense. Directions for making and installing weirs are given in Chapter IV. An automatic alarm may be attached to a tall pole and set in the ground near the weir box. At the top of the pole, a cross arm may be so hung that its heavier end will drop from the horizontal to the vertical position when a catch is released. At the base of the pole, a catch is placed. This catch is attached to a combined weight and float. While the water remains at the right height in the weir box, the catch holds

the cross arm in a horizontal position, but as soon as the level of the water in the weir box is lowered by a decreased flow from the pump, the float permits the catch to release the arm, which falls to the vertical position. Thus the irrigator in the field is notified at once of the trouble at the plant. An electric switch and gong system may be substituted for the pole and signal board.



Fig. 1.—Automatic Semaphore Alarm.

Courtesy of the Montana Experiment Station

Pumping from Wells—In those localities where water is found in large quantities near the surface, it is often profitable to sink a large well from which irrigation water may be pumped. When a well is dug it is always advisable to secure the use of a pumping outfit and run a test on the well of at least ten hours' duration. If the supply shows signs of lessening, the test should be continued until the real capacity of the well is determined.

The sides of such a well should be walled up with a strong curbing, so constructed as to permit water to enter readily.

In many localities where water exists within a reasonable distance of the surface, large drilled wells are now being sunk and vertical centrifugal pumps are being installed. A great many feet of strainer must be attached to the centrifugal pump in order to secure room for the water to enter the pipe. In case such a well is tested and the water immediately goes down when the pump begins to run, it is not advisable to install a large pump, as the "draw-down," or the distance which the water goes down when the pumping begins, will probably be so great that a large pump will exhaust the water supply in a very short time.

Motive Power — Whether the irrigator is to use water power, wind-mills, electric motors, steam or gasoline engines for running his well pump or his centrifugal lift pump for raising river water, is a problem for the engineer to solve, because each pumping plant presents special features. In nearly every case, it proves poor economy for an inexperienced man to select and install a power irrigation pumping plant without consulting an engineer.

CHAPTER III

LOSSES OF IRRIGATION WATER

I. LOSS IN STORAGE RESERVOIRS. II. LOSS IN CANALS. III. EFFECT OF DIFFERENT LININGS ON SEEPAGE. IV. ADVANTAGES OF CONCRETE LINING. V. LOSS IN HEAD DITCHES AND LATERALS. VI. LOSS IN THE FIELD. VII. PERCENTAGE LOSSES OF WATER DIVERTED.

Since water is so valuable for the purpose of irrigation, all losses should be reduced as much as possible.

Loss in Storage Reservoirs—Reservoirs are usually found in connection with irrigation enterprises, except where the flow of water in the stream is steady and sufficient for the season of irrigation. Losses from reservoirs are due to evaporation and seepage. Evaporation is a loss that cannot be prevented and when compared with seepage through an open soil is insignificant. The ideal reservoir is one whose bottom and sides are of rock, but such a one with sufficient capacity is rare, and so the engineer has to do the best he can in selecting the site for the reservoir. A sandy bottomed reservoir should be avoided at all times. A clay puddle, made by scattering straw over the bottom and then driving cattle over it when it is wet, is the most practical substitute for the ideal rock basin.

Loss in Canals—In the canals, losses through evaporation from the surface occur also, but as in the case of reservoirs the loss is small as compared to seepage losses which will average one per cent per mile for canals, and ten to twelve per cent per mile for farmers' laterals. If the water is muddy, the canal will soon silt up, and the losses will be reduced, but if the water is clear and the soil porous, it will continue to be a source of loss and may cause alkali spots to appear at lower levels toward which the water percolates. The loss from canals can be lowered by laying them out through adobe soils in preference to sandy soils, and since the loss from laterals is so large, it is economical to lay them out for as short distances as are possible.

Recently ditch linings have been considered for reducing seepage losses. Olin says, "Any material that is impervious to water and will adhere to the sides and bottom of the ditch, will check seepage, stop erosion of the ditch, and permit of an economical transportation, distribution and use of water."

In selecting material for lining, its cost and its effectiveness in checking the growth of vegetation, the trampling of cattle, and the burrowing of rodents, as well as its efficiency in preventing loss of water, should be considered.

Effect of Different Ditch Linings on Seepage—To prevent seepage

in unlined canals, linings of different materials have been tried. From investigations made in 1906 for the Irrigation Investigations of the United States Department of Agriculture and the California Experiment Station, and from more recent experience on the efficiency of the different types of linings, the following results can be anticipated:

1. A good oil lining, constructed with heavy asphalt road oil, applied on the ditch sides and bed at the rate of about 3 gallons per square yard, will stop 50 to 60 per cent of the seepage.

2. A well constructed clay puddle lining is as efficient as a good oil lining.

3. A thin cement mortar lining about 1-inch thick, made of one part cement to four of sand, will prevent 75 per cent of the seepage.

4. A first-class concrete lining, 3 inches thick, made of one part of cement to two of sand and four of gravel, will stop 95 per cent of the seepage.

5. A wooden lining, when new, is as efficient as a concrete lining, but, after two or three years, repairs and maintenance will become an important item, and by the end of eight or ten years it will require complete renewal.

6. River boulders set in lime mortar and pointed with concrete make a costly but efficient lining.

7. River boulders and cobbles placed behind wooden forms and cemented with cement mortar make a very efficient lining, but its use is warranted only when water and land values are very high.

The cost of an oil lining where oil can be bought at California prices (about 2 cents a gallon) is about $\frac{1}{2}$ cent per square foot. Cement mortar lining 1 inch thick costs about 2 to 4 cents per square foot. Cement concrete 2 inches thick costs from about 4 to 6 cents, and 3 inches thick from about 6 to 8 cents a square foot. These prices do not include the trimming and preparation of the ditch before the lining is put on, which would add from $\frac{3}{4}$ to $1\frac{1}{2}$ cents per square foot. The cost of a clay lining depends greatly on the nearness of the canal to suitable clay. If clay is close at hand it can be hauled and spread on the canal, then either tramped in by cattle or worked in by dragging chains over it, at a cost of less than 1 per cent per square foot, but there are localities where enough money has been spent on clay linings to pay for a good concrete lining. Wooden lining has been used in very few cases, and the cost of such a lining built of 2-inch lumber nailed on sills and side yokes will often be as much as that of a 2-inch concrete lining and not nearly as durable.

The disadvantages of the cheaper linings are the following: An oil lining stops only a part of the seepage losses, and while it will resist erosion well, it probably will not prevent the growth of weeds for more than one season unless a high velocity is used, and it will not stop the activities of burrowing animals. Oil linings have not been sufficiently tested to determine their durability. Clay puddle will not prevent the burrowing of animals and weeds grow rapidly, especially since the velocity of the

water must be small in order to prevent the eroding or washing of the lining.

Advantages of Concrete Lining — A concrete lining has none of the above disadvantages, and it meets the requirements of a good lining better than any other material. The only objection is its higher first cost. But where water is valuable its expense is well justified. In Southern California the use of concrete lining dates from about 1880, when the increasing value of water made it necessary to do away with losses. Since that time practically all canals in that section have been lined with concrete, and in some cases replaced with concrete pipes. Until recently very little concrete lining had been used outside of that region, but during the last few years concrete lined canals have been constructed on many of the projects of the United States Reclamation Service and on numerous private projects. There are now many examples in California, Oregon, Nevada, Washington, Idaho and other states, and during the past three years some good work has been done in British Columbia.

The feasibility of using concrete linings will depend on the extent and value of the water loss and on the necessity for prevention of waterlogging of the land below by the seepage water. Other benefits which must be considered are the decreased cost of maintenance and operation and the greater safety. There are no weeds to contend with, no breaks to mend, and consequently the cost of patrolling is largely eliminated. It must also be remembered that a high velocity can be given to the water in a concrete lined canal, and a smaller and better form of canal can be used, which, especially on a sidehill, will materially decrease the cost of excavation. But even when only the value of the water loss is considered, it does not require a large loss nor a very high price for water for this annual value to represent the interest and depreciation on a capital sufficient to put in a first-class concrete lining.

Loss in Head Ditches and Laterals — Water is lost through evaporation and seepage, in the farmers' supply ditches, head ditches, and laterals in amounts as high as ten to twelve per cent per mile of ditch. Short ditches should be the rule, whenever possible, to minimize this loss. Where water is scarce, it will pay to level the land carefully, and then plan a system of ditches from a topographic map. The supply ditches should be laid out in heavy soil wherever possible because in such soil the seepage losses are less than in sandy soils. This may not always be possible and in that event concrete lining is the best remedy. From the supply ditches the water passes into the "head ditches," thence into the laterals from which the farmer irrigates his lands. Large losses occur through deep percolation in the head ditches and so concrete lined ditches are recommended where water is valuable. However, it is economical to give especial attention to the planning of the distributing system and the leveling of the farm, if the irrigator is planning on a system of concrete lined head ditches. Fig. 2 shows one of these ditches in operation. In the illustration the water is being let into

laterals through slits in the concrete lining. If these were closed the water would flow in a continuous sheet over the lower edge of the section of ditch directly above the check board. This would be well adapted to furrow irrigation, and, if the vents in the sides of the ditch are used, irrigation by a system of laterals can be practiced. Whether the best method of laying the concrete in such ditches is by plastering or by the use of forms is a matter of opinion.

In addition to the advantages stated for concrete linings for canals, the concrete lined head ditches have the following advantages:

1. Water is easily checked and dammed with a check board.
2. There are no weeds to remove, no animals will burrow holes in the ditch, and cows cannot trample and fill in the ditch.
3. The canvas dam is not needed.
4. There is an equal distribution of water on the lands, and the flow is readily adjusted.

Loss in the Field — The final loss in the handling of irrigation water is on the farmers' fields. Evaporation and wasteful methods of irrigation are the causes of this loss and both could be prevented to a large extent by proper soil cultivation and by following scientific principles of irrigation, thus raising the duty of the water. No set rule can be given as to the duty of water, because there are so many factors which vary from year to year and in different districts. Some of the factors which influence the duty of water are:

1. The varying conditions of temperature, wind velocity, and sunshine, which not only differ from year to year, but differ in various localities the same year.

2. The different kinds of crops require varying amounts of water. Alfalfa and clover require more for two or three crops of hay than is required by wheat or oats for the single crop.

3. The kind of soil and the depth of soil will modify the amount of water needed for the same kind of crop.

4. The method of applying water is also a factor which governs the quantity of water necessary.

- (a) Some farmers use an excessive amount of water because they turn it on the land and allow it to flow for the whole season.

- (b) Others do not properly prepare their land but turn on a large head of water and let it flow for several days.

- (c) By the use of an insufficient head of water some parts of a field may be water-logged before all the other parts are covered.

- (d) The farmer who properly prepares and lays out his field, and applies the right amount of water, gets maximum returns from his water supply.

- (e) The irrigator who is handling the water in the field can often save much water and time by carefully studying the problem of applying the water so as to cover the land quickly and evenly.

5. The tillage operations of the farmer should be much the same as in dry farming. In this way he can save enormous amounts of water.

The irrigator should avoid the use of more water than he can properly attend to, for the extra water not only goes to waste, but in its course through the field it often washes deep ditches and gullies.

If there is only a small amount of water available, the irrigator should avoid turning it on the land in too many places at once. He should confine his efforts to a small area and cover this as quickly and evenly as the amount of water will permit and then take up the next area. He should never hesitate to deepen a lateral, to heighten a bank or dam, or to dig a small ditch from a lateral to a high spot if water can be saved by the additional labor.

Percentage Losses of Water Diverted—These losses when assembled indicate that for an average irrigation system the conveyance loss may be fully 40 per cent of the water diverted, and of the amount delivered 25 per cent or more may be lost by deep percolation, 25 per cent may be lost by soil evaporation, and 10 per cent lost by surface run-off; the total of these losses would be 76 per cent of the water diverted.

Where the value of the water will justify it, concrete linings will decrease the conveyance loss to about 5 per cent of the water diverted; the deep percolation loss, where water is used with care, could be very nearly entirely prevented, and would probably not exceed 10 per cent of the water applied; the evaporation loss, where the crops will permit deep furrow irrigation and cultivation, will probably not exceed 15 per cent of the water applied; the surface run-off loss or waste can be eliminated. The total losses for these conditions would be about 27 per cent.

CHAPTER IV

MEASUREMENT OF WATER

I. STANDARDS OF MEASUREMENT. II. THE CIPPOLETTI WEIR. III. THE WEIR BOX OR FLUME—TABLE NO. 1—WEIR DIMENSIONS. IV. PERMANENT CONSTRUCTION OF MEASURING DEVICES. V. RULES FOR SETTING WEIRS. VI. CAUSES AFFECTING ACCURACY OF MEASUREMENT. VII. FORMULA FOR COMPUTING WATER FLOW—TABLE NO. 2.

Every irrigator should have some knowledge as to the amount of water he is using. Several methods of water measurement are available, but the most satisfactory one is by means of the weir. The weir can be made at home, and if installed according to directions given here, will measure water with ninety-nine per cent accuracy. No other method of measuring flowing water is as accurate.

Standards of Measurement—When one cubic foot of water flows through a conduit in a second of time there is a flow of one cubic foot per second. This is the legal standard for the measurement of flowing water, but, due to the fact that water was first measured in connection with mining enterprises, the miner's inch is in common use. The Code of Colorado defines the method for measuring an inch of water as follows:

Water sold by the inch by an individual or corporation shall be measured as follows, to wit: Every inch shall be considered equal to an inch square orifice under a five-inch pressure, and a five-inch pressure shall be from the top of the orifice of the box, put into the banks of the ditch, to the surface of the water; said boxes or any slot or aperture through which such water may be measured, shall in all cases be six inches perpendicular, inside measurement, except boxes delivering less than twelve inches, which may be square, with or without slides; all slides for the same shall move horizontally and not otherwise; and said box put into the banks of ditch shall have a descending grade from the water in the ditch of not less than one-eighth of an inch to the foot.

Almost every state prescribes this method of measurement a little differently, and small variations in the head, shape and size of aperture, etc., will give the inch a different value. It were better to dispense with its use altogether and use the cubic foot per second, but as most adjudications of water rights have been made in terms of miner's inches, the following comparisons are given:

One cubic foot per second is equivalent to 38 Colorado miner's inches, 40 California and Montana miner's inches, and 50 Arizona, Nevada, Utah, Idaho, North Dakota and Nebraska miner's inches. One cubic foot per

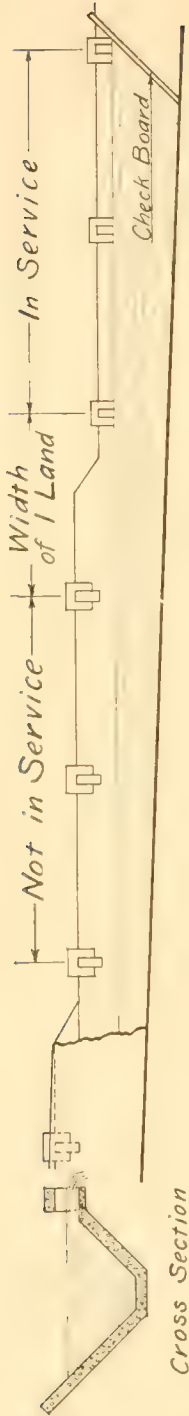

Fig. 2.-Concrete Lined Head Ditch. Water is Flowing into the Three Laterals at the Right.

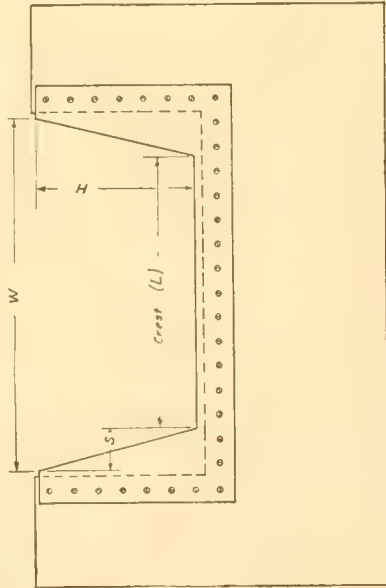

Fig. 3.- Metal-Faced Weir Board. A weir-notch is cut out of a piece of sheet iron and screwed onto a board that has been sawed out as indicated by dashed line. The metal is placed on the up-stream side.



Fig. 4 Showing a Proper way of Measuring the Depth of Water (Head) on a Weir. Note Level of Crest.



Fig. 5. Submerged Weir.

second equals 7.48 gallons per second. An acre foot is a quantity of water sufficient to cover one acre to a depth of one foot. A flow of one cubic foot per second equals one acre inch per hour. One acre foot equals 43,560 cubic feet or 325,851 gallons. To ascertain the time in hours necessary to cover a given tract of land with water to a depth of one foot from the available water supply, multiply the number of acres by 12.1 and divide this sum by the number of cubic feet of water per second flowing in the ditch. The only unknown factor in this computation is the number of cubic feet per second,

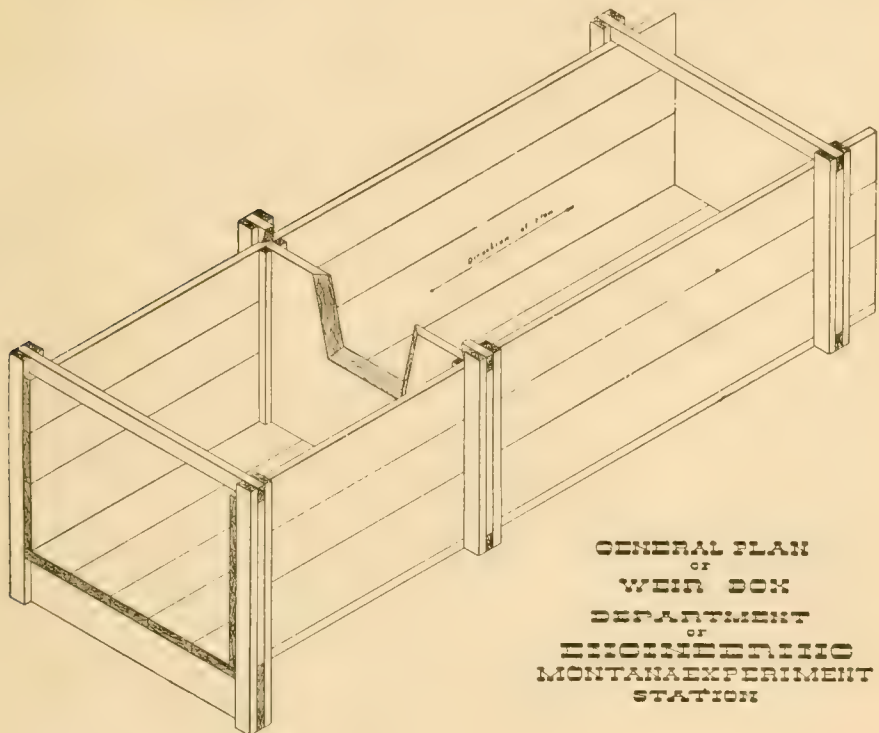

Fig. 6.—Weir Box.

Courtesy of the Montana Experiment Station

and this can be determined with the use of the weir by any man who can work arithmetic, according to a formula to be given later. To make the computation easier a table for different sized weirs will be given.

The Cippoletti Weir — A weir is a structure designed to allow water to pass over it with an appreciable fall on the lower side. It consists essentially of a notch in a board, but in order to obtain any accuracy in measurement, there are certain essential requirements in its shape, construction and operation. The weir is one of the most accurate, cheap, and satisfactory means for measuring flowing water, and it can be more generally used than

any other device. Cippoletti, an Italian engineer, invented the Cippoletti weir, which is more widely and successfully used than any other in the irrigated districts of the world. It has a thin horizontal crest, the sides of the weir-notch sloping back at an angle of 1 inch horizontally for 4 inches vertically. That is, for each additional depth of one inch the weir-notch widens $\frac{1}{4}$ inch on *each* side. See Fig. 3. This form of weir avoids many of the difficulties encountered in other forms and should be used in preference to all other kinds. The weir notch on the bottom and on the sides should be beveled to a thin edge on the up-stream side, and sufficiently to prevent the water from touching the crest save at the thin edge. A vertical section through the weir board should resemble that shown in Fig. 4.

A convenient method of weir construction is to cut a weir notch out of a sheet of thin galvanized iron, and securely fasten it to the upstream face of the weir board, into which has been previously cut a rectangular notch a little larger than the notch in the metal. Fig. 3 will give an idea of this form of construction.

The slope of the sides should be 1 to 1, as previously explained; that is, if H in Fig. 3 is 8 inches and L is 20 inches, then W should be $\frac{1}{4}$ of H wider on each side, or $20+2+2$, or 24 inches. Any size may be constructed by following the same method.

The Weir Box or Flume—Although there are advantages derived from placing the weir board in a specially constructed box or flume, it is not essential for securing accurate measurement of water. The weir box has the advantage that, where built according to the following dimensions, the rules for setting become exceedingly simple, and the results can be relied upon for accuracy. The principal disadvantage is that it is frequently difficult to prevent seepage under and around the box. If the weir box is used, it is important that it be made of sufficient size, in comparison with the weir notch, to insure against any velocity of approach. Results will not be correct if the weir box is too small for the weir notch.

It is possible to build a weir box of concrete, reinforced with wire, rods, or netting to prevent cracking and checking. The inside dimensions should be the same as given in the table of weir dimensions. Aprons to prevent underseouring may be made by digging a trench under and beside the box, and filling in with concrete. The floor should be put in by continuous work, so that none of the concrete will be set before that in contact with it is in place. The reason for this is that new concrete will not bind well to that already set. Special attention should be given to connecting the apron to the bottom of the box with reinforcement. Concrete should be kept covered and damp for several days after pouring. This can be done by covering with dirt as soon as it is sufficiently set to keep the dirt from indenting it, or it may be done with gunnysacks or other material. Bolts may be cast into the walls and bottom of the box to which may be attached the weir board.

Fig. 6 shows a good design for a weir box. The weir box dimensions for various sizes of weirs are given in the following table:

TABLE No. 1
WEIR DIMENSIONS

Dimension L	A-B	C-D	E-F	G-H	L	I-H	Apron
1-foot weir.....	48 in.	12 ft.	16½ in.	18 in.	1 ft.	9 in.	2x12 in.
1½-foot weir.....	60 in.	12 ft.	23¼ in.	21 in.	1½ ft.	10½ in.	2x12 in.
2-foot weir.....	72 in.	14 ft.	30 in.	24 in.	2 ft.	12 in.	2x12 in.
3-foot weir.....	90 in.	16 ft.	42¾ in.	27 in.	3 ft.	13½ in.	2x12 in.
4-foot weir.....	108 in.	16 ft.	55½ in.	30 in.	4 ft.	15 in.	2x12 in.
5-foot weir.....	128 in.	18 ft.	68½ in.	34 in.	5 ft.	17 in.	2x12 in.
6-foot weir.....	144 in.	18 ft.	81 in.	36 in.	6 ft.	18 in.	2x12 in.
7-foot weir.....	155 in.	20 ft.	93 in.	36 in.	7 ft.	18 in.	2x12 in.
8-foot weir.....	168 in.	20 ft.	105 in.	36 in.	8 ft.	18 in.	2x12 in.
9-foot weir.....	170 in.	22 ft.	117 in.	36 in.	9 ft.	18 in.	2x12 in.
10-foot weir.....	184 in.	24 ft.	129 in.	36 in.	10 ft.	18 in.	2x12 in.
15-foot weir.....	222 in.	24 ft.	189 in.	36 in.	15 ft.	18 in.	2x12 in.

L is the length of the crest of the weir-notch.

A-B is the distance between the sides of the box.

C-D is the length of the weir box.

E-F is the width of the weir-notch at the top.

G-H is the distance from the crest of weir-notch to the bottom of the weir box.

I-H is the distance from the crest of the weir-notch to the top of the weir board.

The size of weir to be constructed should be decided after consulting the tables for discharge over Cippoletti weirs given in Table No. 2.

Placing the Weir Box—There is danger where the weir box is used of placing it too close to a headgate above. It should be placed sufficiently far below the headgates to insure against any velocity of approach or any cross currents or eddies. Care should be taken to see that the material about the box is compacted or puddled sufficiently to prevent under-scouring. Sometimes it will be found necessary to use sheet piling if the box is large and the soil of a nature that washes easily or that is too porous. Sometimes an apron wall and wings are necessary. These may be made of the same material as the box. If the box is of concrete, it is usually advisable to build these walls when the box is constructed and thus make them of one solid piece.

Weirs Without the Box or Flume—A more economical method of placing a weir is to make the weir board take the place of wings and apron and to dispense with the weir box. The falling water will tend to cut out the bottom of the stream immediately below the weir; therefore the weir board should extend well below the bed of the stream, and the latter should be protected with stones or a floor of boards. Be sure to follow the general rules for setting, and do not allow the upper face of the weir board to silt up closer to the crest than provided by rule. Fig. 7 shows the correct method of making and setting a weir board without the box or flume.

Permanent Construction of Measuring Devices—In streams infrequently rated and having extreme variations in flow, a concrete weir is

economical, convenient, and serviceable. It sometimes occurs that a stream will discharge a quantity of water at some seasons of the year, which requires a large weir to measure, while at other times the flow would best be handled by a small weir. In such cases more accurate ratings can be made by having two or more weir boards with different sized openings to use as the occasion demands. These boards can be made of the same over-all dimensions so that they may be interchangeable in the same seat.

By this method the portion of the weir board that extends into the sides and bottom of the stream is made of concrete, preferably reinforced with wire or netting. The opening left in this concrete wall is of such size as to admit the board containing the weir notch. The board is not fastened to the concrete, but rests against the supports which are built into the concrete. If well built, this form of weir gives very satisfactory results and offers permanent construction, which is desirable where there has been trouble

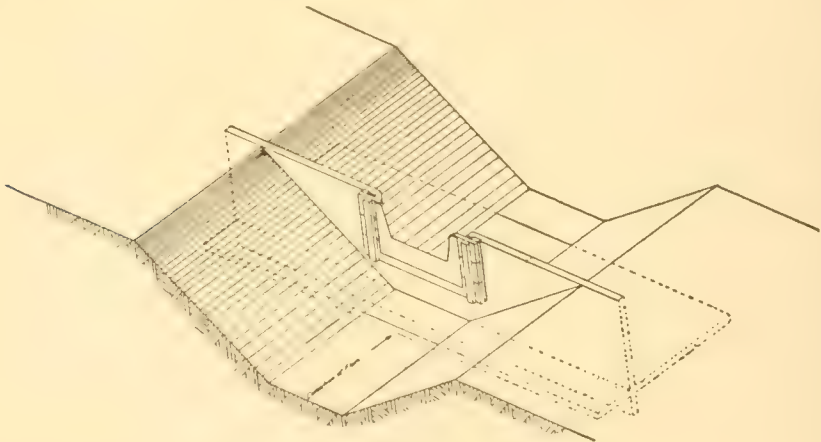

Fig. 7.—Cippoletti Weir Set in Concrete.

Courtesy of the Idaho Experiment Station

with soil washing. With the unsettled condition of water rights in the West, sufficient care is not being given to the proper construction of measuring devices. Most weirs are placed too carelessly to insure accurate measurements, and they are usually made of wood which is subject to decay, leakage and breakage. With the more pressing demands for accurate and permanent irrigation structure, economy will be best served by concrete construction.

Rules for Setting Weirs — (1) The channel above the weir should be straight and long enough to allow the water to approach the weir at right angles and without eddies or cross currents.

(2) The weir should be in a vertical plane at right angles to the current of the stream. If any current is perceptible it should set toward the center of the overflow space of the weir.

(3) The water should be brought, as nearly as possible, to a state of

rest above the weir either by means of a lake or pond, or by widening and deepening the channel above the weir. For weirs less than three feet long at the crest the velocity of approach should not exceed six inches per second. For weirs between three and six feet long on the crest the velocity of approach should not exceed eight inches per second. In all cases the area of cross section above the weir in the stilling pond should not be less than seven times that of the weir notch.

(4) The overflow space should have full contraction, that is, both sides and bottom of the weir notch should have faces at right angles to the current equal to at least twice the normal depth of water expected to pass over the weir notch.

(5) The layer of falling water should be perfectly free from the walls below the weir, in order that air may circulate freely underneath. The level of the water below the weir has no influence on the discharge of the weir unless it rises high enough to prevent this free circulation of the air. Whenever this circulation of the air is stopped, the weir becomes a submerged weir and the tables given in the bulletin do not apply. Fig. 5 shows a submerged weir.

(6) The weir notch should be beveled to a knife edge on the upstream side, the beveling or cutting away being done on the lower side. (See Fig. 4.) The crest should be level, and the board set vertically.

(7) The length of the crest, L , should be such that the depth of the water passing over it shall not be more than one-third of this length.

(8) The distance from the crest of the weir to the bottom of the canal on the upstream side should not be less than twice the depth of water flowing over the weir. The distance from the ends of the weir crest to the sides of the weir box should be about twice the depth of water on the weir.

(9) In measuring the depth of water passing over the crest, the level of the still water above the weir should be considered, and not the water exactly over the crest. The weir peg driven into the bed of the stream should be far enough above the weir to avoid the curve of the surface as it passes through the notch. This curve can be plainly seen from below by placing the eye level with the surface of the water above the weir. This curve runs farther up stream when the depth of water is large on the weir. A weir peg is usually driven into the bed of the stream just above the curve of approach and near one side. It is then sawed off level with the crest, and measurements for depth taken from the top of this peg to the surface of the water above it. (See Fig. 4.) This depth measurement should be correct to 1-300 part of the depth to keep the error within $1\frac{1}{2}$ per cent of the amount flowing. There are devices that enable the irrigator to measure the head, H , on the weir without using the peg, and to get results much more accurate than can be obtained from the peg, especially when a ripple is caused on the surface by the wind. The most accurate of these devices consists of a still box attached to the side of the weir box and containing a hook gage for reading the depth. Such a device costs about \$25.00. The Howell

measuring instrument costs about \$15.00 and is portable but not so accurate as the hook gage. In place of a still box, a glass tube may be let into the side of the weir box, and the depth noted on the tube. One of these devices can be bought and installed for less than a dollar and can be made to give very accurate results.

Causes Affecting Accuracy of Measurement—The causes that affect accuracy of measurement may be divided into three classes: Those which tend to render the computed amount too large; those which render it too small; and those which may render it either too small or too large.

The measurement of the depth of water is as likely to be too large as too small and the results will balance in the long run. If the weir is not placed at right angles to the stream, the computed amount will be too large. A marked velocity of approach, incomplete contraction, silting up above the weir, render the computed amount too small. The tendencies to render the computed amount too small are rather more in number than those that render it too large, and they are somewhat harder to overcome. Perfect conditions are not always possible, and much will depend upon the observer's experience and knowledge of hydraulics.

If a weir is not vertical, the discharge is increased or diminished according as the inclination is down or up stream. The correction may amount to as much as 4 per cent for an inclination of one horizontal to three vertical.

If the sides are too close the discharge will be more than the computed amount. If the distance is greater than twice the depth of water on the weir, the discharge will not be affected.

If the bed of the stream immediately above the weir is too close to the crest, it will render the computed amount too small. When the depth below the crest on the upstream side is at least three times the depth of water on the weir the error is not appreciable; if equal to the depth of water on the weir the error may reach $1\frac{1}{2}$ per cent. In consequence of this cause of error the weir should always be kept clear of silt on the upstream face.

It is not difficult to set a weir correctly, neither is it difficult to measure water with the weir correctly, when it is properly set. All that is necessary is to follow the rules here set forth and the weir becomes the most accurate, economical and efficient of all measuring devices.

Formula for Computing Water Flow—The formula for computing the flow of water in cubic feet per second over Cippoletti weirs is: $Q=3.366 L H^{3/2}$.

Q =Cubic feet per second.

L =Length of the crest of the weir.

H —Head of water, measured according to rule 9 of Rules for Setting Weirs.

The interpretation of this formula is: Cube H , extract the square root, multiply by L and 3.366 and the answer is Q . But to make this easier for the irrigator the following table is given in which the flow in cubic feet per second is given for different sized weirs under different heads.

TABLE No. 2
DISCHARGE OF CIPPOLETTI WEIRS 12 to 60 INCHES LONG IN CUBIC FEET PER SECOND
COMPUTED FROM FORMULA $Q=3.367LH^{3/2}$

Head, H		Length of weir L, inches													
In.	Ft.	12	13	14	15	16	17	18	19	20	22	24	36	48	60
3/4	.042	.03	.03	.04	.04	.04	.04	.04	.04	.04	.06	.0619
6/8	.052	.04	.04	.05	.05	.05	.06	.06	.06	.07	.07	.08	.11	.15	.25
1 1/8	.062	.05	.05	.06	.06	.07	.07	.08	.08	.09	.10	.10	.15	.20	.31
1 1/4	.073	.07	.08	.08	.09	.09	.10	.10	.11	.12	.13	.13	.19	.25	.38
1 3/8	.083	.08	.09	.09	.10	.11	.11	.12	.13	.13	.15	.16	.23	.30	.46
1 1/2	.094	.10	.11	.12	.12	.13	.14	.15	.16	.17	.18	.19	.27	.36	.53
1 5/8	.104	.11	.12	.13	.14	.15	.16	.17	.17	.18	.20	.23	.32	.43	.64
1 7/8	.115	.13	.14	.15	.16	.17	.18	.20	.21	.22	.24	.26	.37	.49	.71
2	.125	.15	.16	.18	.19	.20	.21	.22	.24	.25	.28	.30	.42	.56	.80
2 1/8	.135	.17	.18	.20	.21	.23	.24	.25	.27	.28	.31	.33	.47	.63	.91
2 1/4	.146	.19	.21	.22	.24	.25	.27	.28	.30	.32	.35	.38	.53	.70	.98
2 3/8	.156	.21	.23	.24	.26	.28	.30	.31	.33	.35	.38	.42	.59	.78	1.18
2 1/2	.167	.23	.25	.27	.29	.31	.33	.34	.36	.38	.42	.46	.71	.94	1.39
2 5/8	.188	.27	.29	.32	.34	.36	.38	.41	.43	.45	.50	.55	.84	1.12	1.62
3	.208	.32	.35	.37	.40	.43	.45	.48	.51	.53	.59	.64	.97	1.30	1.92
3 1/8	.229	.37	.40	.43	.46	.49	.52	.55	.59	.62	.68	.74	1.11	1.48	2.16
3 1/4	.250	.42	.46	.49	.52	.56	.60	.63	.66	.70	.77	.84	1.26	1.68	2.40
3 3/8	.271	.47	.51	.55	.59	.63	.67	.71	.74	.78	.86	.95	1.42	1.89	2.66
3 1/2	.292	.53	.57	.62	.66	.71	.75	.80	.84	.88	.97	1.06	1.58	2.10	2.93
3 5/8	.312	.59	.64	.69	.74	.79	.84	.88	.93	.98	1.08	1.17	1.74	2.32	3.20
4	.333	.65	.70	.76	.81	.87	.92	.97	1.03	1.08	1.19	1.29	1.92	2.55	3.49
4 1/8	.354	.71	.77	.83	.89	.95	1.01	1.06	1.12	1.18	1.30	1.42	2.09	2.79	3.79
4 1/4	.375	.77	.84	.90	.96	1.03	1.09	1.16	1.22	1.28	1.41	1.55	2.27	3.03	3.99
4 3/8	.396	.84	.91	.98	1.05	1.12	1.19	1.26	1.33	1.40	1.54	1.68	2.56	3.41	4.26
5	.417	.91	.99	1.06	1.14	1.21	1.29	1.36	1.44	1.52	1.67	1.81	2.75	3.66	4.58
5 1/8	.438	.98	1.06	1.14	1.22	1.30	1.38	1.46	1.55	1.63	1.80	1.95	2.95	3.93	4.91
5 1/4	.458	1.04	1.13	1.21	1.30	1.39	1.47	1.56	1.65	1.73	1.91	2.09	3.15	4.20	5.25
5 3/8	.479	1.12	1.21	1.31	1.40	1.49	1.58	1.67	1.77	1.87	2.05	2.23	3.36	4.48	5.60
6	.500	1.19	1.29	1.39	1.49	1.59	1.68	1.78	1.88	1.98	2.18	2.38	3.57	4.76	5.95
6 1/8	.521	1.37	1.48	1.58	1.69	1.79	1.90	2.01	2.11	2.32	2.53	3.79	5.05	6.31
6 1/4	.542	1.46	1.57	1.68	1.80	1.91	2.02	2.13	2.24	2.47	2.69	4.01	5.34	6.68
6 3/8	.562	1.66	1.78	1.89	2.01	2.13	2.25	2.37	2.60	2.84	4.23	5.64	7.05
7	.583	1.75	1.88	2.00	2.12	2.25	2.38	2.50	2.75	3.00	4.46	5.95	7.44
7 1/8	.604	1.98	2.11	2.24	2.37	2.50	2.63	3.00	3.16	4.69	6.26	7.82
7 1/4	.625	2.08	2.22	2.36	2.50	2.64	2.78	3.06	3.33	4.93	6.57	8.22
7 3/8	.646	2.33	2.48	2.62	2.77	2.91	3.20	3.50	5.29	7.06	8.82
8	.667	2.44	2.60	2.75	2.90	3.06	3.36	3.67	5.54	7.38	9.23
8 1/8	.688	2.72	2.88	3.04	3.20	3.52	3.84	5.79	7.72	9.65
8 1/4	.708	2.84	3.01	3.18	3.34	3.68	4.01	6.04	8.06	10.07
8 3/8	.729	3.14	3.31	3.49	3.84	4.19	6.30	8.40	10.50
9	.750	3.28	3.46	3.64	4.01	4.37	6.56	8.75	10.93
9 1/4	.771	3.61	3.80	4.18	4.56	6.82	9.10	11.37

The ordinary irrigator will never use more than ten cubic feet per second, so the above table is deemed complete enough. Ten cubic feet per second would cover one acre to a depth of one inch in six minutes. This is more water than one man can handle.

CHAPTER V

SELECTION AND PREPARATION OF LAND FOR IRRIGATION

- I. CHOICE OF LAND. II. CLEARING THE LAND. III. PREPARING THE SEED-BED. IV. DITCH CONSTRUCTION. V. STRUCTURES FOR WATER DISTRIBUTION—SIPHONS—FLUMES. VI. HEAD DITCHES. VII. WASTE DITCHES.

Choice of Land—The prospective irrigator must assure himself that his water rights are not so clouded by "prior rights" as to make his supply of water insecure and indeterminate at the proper time to irrigate his land. Prior rights are, however, by no means essential to successful irrigation providing the stream is sufficiently large and steady of flow to satisfy the late rights as well as the prior rights.

The land selected may be a considerable distance above the stream level, for the streams in the West have a fall of from 10 to 125 feet per mile while the irrigator's canal requires a fall of only 4 feet to the mile. However, it is necessary that the water which supplies the farm be taken out from the stream a mile or two up stream. Irrigation farming may be profitable with pumped water up to a certain limit of height, and, for certain kinds of crops, it is profitable to elevate it higher than for others.

The best soils for irrigation are loams and silt loams. In a sandy soil there is much loss of water by deep percolation; on a heavy, clayey soil it is difficult to get the water into the soil and it must be allowed to stand on the land for some time. If the soil is sandy it should have considerable slope so that the water can be gotten to the lower end of the "lands" from the "head ditch" before it all soaks in. The clay soil should have a gentler slope so that the water runs over the land slowly, giving the clayey soil time to absorb the water.

Clearing the Land—In most cases sage brush will have to be removed from new land and the machine shown in Fig. 8 will prove very serviceable for this purpose.

After the brush is removed the land must be leveled off.

For this purpose the plow and the scraper are used. Fig. 9 shows a small grader than can be used in transplanting soil from high or low spots in the field. The ordinary "buck" scraper or a road grader is often used. After the land has been plowed and well pulverized by the use of the disk and peg-tooth harrow, the leveling process is finally completed by the use of a home-made leveler shown in Fig. 10. The proper leveling of new fields is very important, for it saves water, saves times, and permits a more uniform application of water. It is sometimes necessary to go over the land two or more times with this leveling device before applying water. The

less slope to the land, the more carefully must it be leveled. Depressions that have been filled in will not remain level. After the first few irrigations the soil will settle, and it is difficult to estimate just how much. So it is best to seed grain for the first crop and to relevel the land in the fall.

Preparing the Seed-Bed—Plowing is in all cases done in such a manner as to leave no dead furrows on the land. For this the "two-way" plow or a reversible disk plow is used. By the use of this plow all furrows are turned one way avoiding "back furrows," "dead furrows," and low

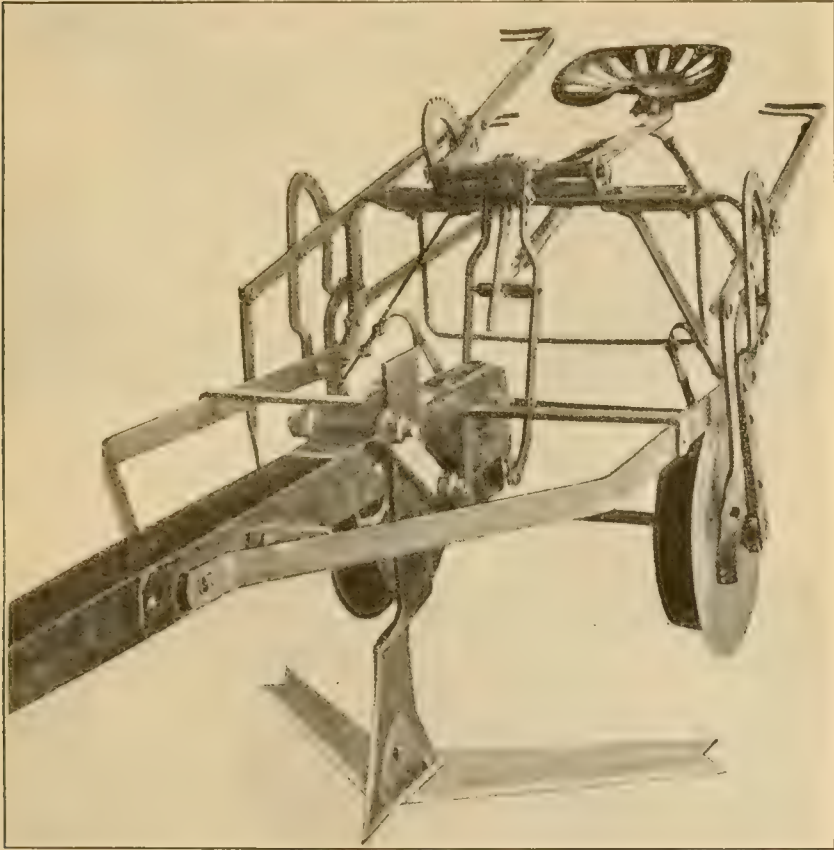

Fig. 8.—Sage Brush Cutters

Courtesy of the Montana Experiment Station

corners. The subduing of sage brush land is best done by two plowings, the first one being shallow, after which the sage brush is raked up and burned. Then the land is plowed to the proper depth (about 8 to 10 inches).

Prairie sod should be plowed so that the furrow slice lies flat in the furrow with the sod down. The disk and the peg-tooth harrow are the implements used in pulverizing. The harrowing should be done as soon as possible after plowing so as to conserve moisture for the germinating seed.



Fig. 9.—A Small Grader being used to transport earth from a high spot to lower ground. It takes the place of the scraper.

Courtesy of the Montana Experiment Station

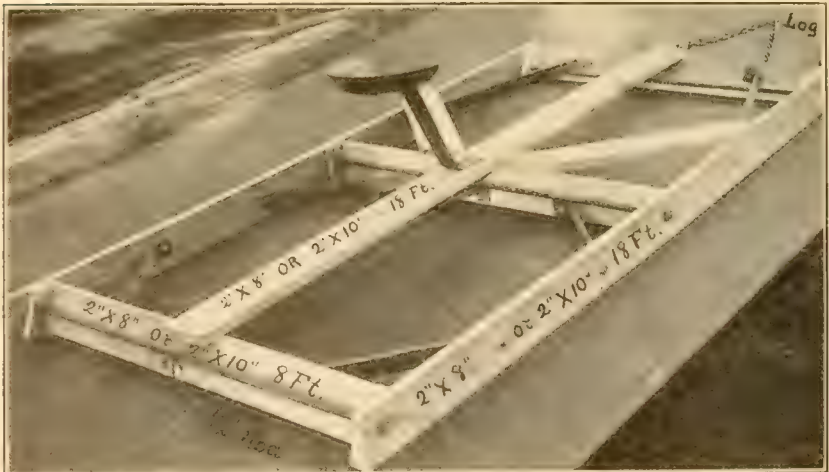

Fig. 10.—Dimension photograph showing how to make an Irrigation Leveler.

Courtesy of the Montana Experiment Station

It is poor practice to irrigate before the plants are large enough to shade the land to some extent. Alfalfa sod should be plowed about 5 inches deep with a special alfalfa shear which cuts off all the roots and prevents the growth of "volunteer" alfalfa. It should be irrigated after the first plowing, because the moisture hastens decay. In the spring the field should be plowed again to a depth of eight to ten inches and the humus turned under.

Ditch Construction—The plow, scraper, and grader in conjunction with shovel, pick, and spade are the implements used in making the permanent ditches on the farm. The supply ditches and in most cases the head



Fig. 11.—Homemade Log Ditcher. The slope of the front is very gradual, thus giving a smooth ditch. The plank wings crowd the bank, leaving it hard, smooth and firm.

Courtesy of the Montana Experiment Station

ditches are permanent while the laterals are temporary. The lining of permanent ditches with concrete requires the special machinery of the cement worker. The fall of the permanent ditches should be at least four to five feet per mile and of the laterals at least eight feet to the mile. Too much fall in earth ditches should be carefully guarded against as it causes great damage by erosion and washing.

Lateral ditches are made by the log ditcher (Fig. 12) or by the double mouldboard plow. The engineer's level should be used in making a topo-

graphic map in preparation for laying out the ditches. Various home-made leveling devices can be used in laying out ditches on land with sufficient slope. A wide ditch with a rounded bottom is preferable to an angular one. The lister or double mouldboard plow is likely to leave a ditch with crumbling sides. These can be smoothed by the log ditcher or the adjustable irrigation V, but time can be saved by doing both operations at once with the log ditcher.

Structures for Water Distribution—Head gates deliver the water from the main canal of the public stream into the farmer's supply ditch. It is here that the owner of the canal or the water commissioner measures the farmer's water, and all losses thereafter are the farmer's. The head gates should be of steel and set in concrete. They are operated by screw

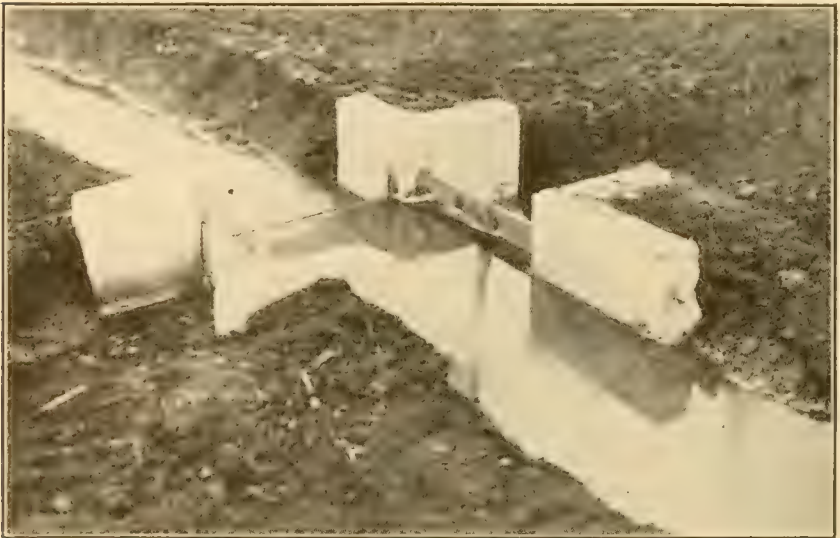

Fig. 12.—Concrete Division Box.

Courtesy of the Montana Experiment Station

wheels or levers, and these should be kept locked by the ditch rider. Head gates of wood shrink, warp, rot, and get broken and are very unsatisfactory.

Weirs for measuring the amount of water should be placed some distance from the head gate. This is the place where the farmer should measure the amount of water he receives. He should also have weirs for each head ditch so as to know where he is using his water. They are easily put in according to directions already given and furnish him reliable data concerning his irrigating plant.

Division boxes take the place of head gates in the farmer's supply ditch, because they are less expensive. They should also be made of concrete. The floor is first made by tamping in a layer of concrete, six to eight inches thick, and as soon afterward as possible setting and filling the moulds for

the side walls. If the moulds are well made, they may be used for any number of boxes. They should be held together by clamps or bolts, so that they may be easily taken apart when the cement has set.

The grooves into which the gates fit are made by fastening a strip of wet wood of the proper shape to the mould at the correct location. The wooden strip should be lightly tacked to the form so that when the latter is removed the strip stays in the concrete. As soon as the strip dries out, it can be removed from the concrete without trouble.

The gates or check boards for these division boxes may be made of 7-8 boards nailed to cleats.

The floor and sides of the concrete division boxes should be reinforced with twisted wire, barbed wire, small steel bars, or a piece of strong woven wire fence. Special attention should be given to reinforcing the corners of the box, as otherwise these are likely to crack. By placing a low board in

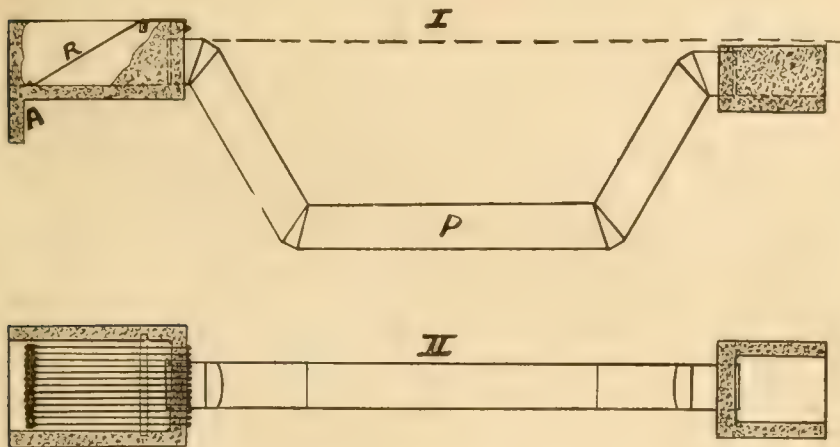

Fig. 13.—An Inverted Siphon for Carrying Water Over a Sag in the Ground.

Courtesy of the Montana Experiment Station

one of the slots to "baffle" the water, the box is made to act as a drop, thus checking the rate of flow of water in the ditch. This often becomes necessary in ditches which wash badly.

Siphons — An inverted siphon (shown in Fig. 13) is used to carry a stream of water over a sag in the ground. Sometimes a ditch, known as a "borrow ditch," is built up out of loose earth for the same purpose. These are the terror of the irrigator. Gophers and moles will burrow holes through their walls, the water may rise a little above the walls and break out, and other disastrous things may occur. The inverted siphon does away with this obnoxious "borrow ditch." It is usually made of vitrified clay tile well cemented together. Galvanized sheet iron has recently come into common use. To prevent clogging of the siphon the iron grate (R) is placed on the upstream side to catch weeds and rubbish.

Flumes—Flumes are used in carrying water over ravines and from the spout of the pumping station to higher ground. Flumes made of planks are fairly satisfactory, but it is nearly always more economical to use a galvanized sheet iron flume. When the flumes are very long provision must be made for the expansion and contraction with changes in temperature or the pipes will buckle or break loose at the ends. When they buckle they raise up from their support and water will not flow through them. The galvanized sheet iron flumes are both open and closed. The open ones form a round bottomed trough. As a substitute for flumes, reinforced concrete conduits in which the water is under a low pressure, are being used in some places.

Head Ditches—The head ditch is the one from which the irrigator lets the water onto his "lands" either through a system of laterals, furrows, or "borders." It is usually made as already described under making ditches, but the concrete lined head ditch shown in Fig. 2 is a distinct improvement over all previous ones. It was devised by an Arizona engineer. The sides have a 45 degree slope, that being the angle of repose of soil. The upper side of the ditch is higher than the one to be irrigated from. This lower side has a lip for each "land." These lips have an adjustable opening so that the amount of water going onto each "land" can be regulated or evenly distributed among the three lands. Instead of using a canvas dam, a check board with sides at an angle of 50 degrees is used. The weight of the water upon it causes it to stay in place. Two of these boards are needed, and the second one is put in place before the first one is removed, thus saving the dammed up water used for the preceding irrigation.

Waste Ditches—Unless the irrigator can judge very well just how much water he will need, it will be necessary to provide waste ditches to carry off the excess water; otherwise it will collect in low places and form swamps or alkali spots.

CHAPTER VI

METHODS OF WATER DISTRIBUTION

- I. OVERHEAD SPRAYS. II. SUB-IRRIGATION. III. IRRIGATION BY FLOODING. IV. FLOODING BY THE FLOWING SHEET OF WATER. V. FLOODING DIKED LAND WITH STANDING WATER. VI. BORDER IRRIGATION. VII. FURROW IRRIGATION—IRRIGATION OF POTATOES BY FURROW METHOD. VIII. CONCLUSION—IRRIGATION DETAILS.

Mead reports that there are over thirty methods of distributing irrigation water in use in the United States. Each of these has special adaptations as to crop, soil, water supply, climate, and slope. All of these methods cannot be described in this chapter but some principles governing their use will be given. All of these thirty methods may be divided into four general groups—overhead sprays, sub-irrigation, flooding, and furrow distribution.

Overhead Spray—Overhead sprays are economical only in the growing of shallow-rooted crops and truck crops where the water has to be pumped and the system is used only to tide over some hot, dry spells. The initial cost is high, but after that it offers the most economical method of using the water. There is no land wasted in ditches, and the water can be applied at the desired point. However, loss of water by evaporation is great, and the system is very expensive and not adaptable to general farming or even fruit growing.

Sub-Irrigation—Sub-irrigation is the watering of the land through a system of underground tile, which may at the same time serve as a drainage system. The water gets out of the line of tile between the sections. The advantages of such a system are: (1) It does not have so great a loss of water by evaporation and seepage as other systems. (2) As a result it reduces the tendency for alkali spots to form. (3) It avoids the cutting up of the land with many ditches. (4) The soil is never puddled and the farm can be cultivated as a dry farm and so moisture is saved. (5) Water is applied at a low cost.

The disadvantages of the system are: (1) Roots have a strong tendency to enter the tile and clog them. This makes the system of porous clay tile unsuitable for orchards and alfalfa fields. It is better adapted to annual plants such as truck and cereal crops. (2) Water may not get out of the tile system fast enough to supply the plants. (3) The cost of installing such a system is too great to be practical on most farms.

A modification of this method is the use of vitrified tile, well cemented together, with vertical standpipes for the water to run out of and irrigate in a little furrow around the tree. This system is often used in orchard

irrigation in California with very satisfactory results. The laying of 8 or 10-inch tile below the plow is not expensive and with tile of this size the system is practical. In a region like Arizona where evaporation and transpiration are high, 8 or 10-inch tile would not provide sufficient water for the crops, and the cost of laying 20 to 24-inch tile (the size often needed in Arizona) below the plow is prohibitive for such a system.

Irrigation by Flooding—There are two distinct types of flooding: (1) A sheet of flowing water is maintained until the desired degree of saturation is obtained; and (2) the surface is covered with a sheet of standing water until the soil is saturated. In the United States the first system is the one in most common use. On gently sloping land of moderately porous character, and not easily washed or puddled, so that the water can be controlled, the first method is most convenient. On very level land or very steep land, that has been terraced as in China, the second method is often used.

The flooding system is best adapted to certain classes of crops such as grain and hay. The flooding system is sometimes employed to soak the land before planting, after which dry farming is practiced.

The advantages of any kind of flooding are: (1) The cost of applying water is small, for the water is easily and cheaply handled, and the cost of the irrigation structures is low; (2) the percentage amount of land in a field not actually in crop is very small, for there are no irrigation furrows. However, the flooding system wastes water, may cause the appearance of alkali spots, makes moisture-conserving cultivation impossible, and injures some crops by causing a crust to form over the soil.

Flooding by the Flowing Sheet of Water—This is accomplished as follows: The irrigator takes his canvas dam, or his check board, if he has a concrete lined head ditch, about three lands down the head ditch and dams up the water. The water from the head ditch now flows into the laterals. The laterals have been previously dammed at intervals with earth or manure. When the upper dams in the laterals have diverted enough water onto the crop they are removed and the water passes down to the next dam in the lateral. When the end of the lateral is reached, another canvas dam or check board is taken three "lands" down the head ditch and set up. The first one is then removed and the watering operation is repeated. The distance between laterals depends on the kind of soil and slope of the land. On rough or on very sandy land the laterals should not be more than four rods apart, while on properly leveled, not too sandy land, they may be eight rods apart. The same factors determine the distance between dams in the laterals. These dams are made of manure or by scraping the loose earth in the bottom of the lateral into piles with a horse-drawn, home-made scraper. Small openings are made in the lower sides of the laterals to let out the water. If the laterals are laid out with almost no fall, then for a second or third irrigation no damming of the laterals is necessary. With this system very careful leveling of the land is necessary.

If only a small head of water is available, or if the soil is sandy so that it is difficult to force the water to the end of the laterals, it is better practice to use but one or two laterals at a time. Care should be taken that the soil does not become water-logged at the upper end of the laterals while the lower gets no water. Waste ditches should always be provided to carry off the excess water.

All laterals and waste ditches should be plowed in as soon as the irrigating season is over because they are an excellent weed garden and insect breeder.

Flooding Diked Land With Standing Water — On very steep slopes this method of irrigation is made possible by terracing the land and diking each terrace, but this method is practical only where labor is cheap and land dear. On level land this system of irrigation is easily accomplished by throwing up "checks" or dikes along the contour lines. (Contour lines are lines connecting points of the same elevation.) These low banks are made by means of the ditch plow and the irrigation V, or, in case of large checks, by means of plows and scrapers. The checks are usually located on contour lines so spaced that the ground at each check is about 3 or 4 inches lower than at the check above.

The levees or dikes should be low and wide so that mowers and other farm machinery can pass over them without difficulty. The strips of land enclosed by these checks or dikes are further divided into plots of from one to two acres, by means of dikes which run up and down the slope. Water is turned into the plots from ditches through "check boxes" or gates. The dikes are also provided with gates which can be opened to allow the water to flow from a check plot when it has been sufficiently irrigated.

If the land is properly leveled and the checks are properly laid out and built, a very rapid and satisfactory irrigation system results. In some cases the checks are as large as twenty acres, but it has been observed that the smaller checks give much better satisfaction. In many localities it is customary to use large heads of water when irrigating by the check system. Heads as large as twenty cubic feet per second are often turned in upon a plot until the land is properly irrigated. With such a head about twenty to thirty minutes of flow are allowed for each acre of land in the plot or check. Unless the land be properly leveled before this system of irrigation is used, there is danger of the large heads of water washing ditches and gullies in the soil.

Border Irrigation — This is another form of flooding. In the preparation of a field for border irrigation, a large ditch is laid out along the highest side of the field. Dikes are then so constructed that they run directly down the slope of the field. These are low and broad and are, as a rule, composed of the soil removed from nearby hummocks and knolls. The work of building a dike may be done with a Fresno scraper or by means of some form of grading machine. The dikes should be well rounded so that they do not interfere with tillage. The land should be so leveled that, when the

water is turned upon it from a box or gate in the head ditch, all the land between the borders will be evenly covered with water. This system proves satisfactory in case plenty of water is available and the leveling and diking are properly done.

Furrow Irrigation — In order to irrigate crops which are planted in rows, the furrow method is often employed. In fact, the furrow method is being used in many localities, not only for the irrigation of crops which are planted in rows, but for grains, meadows, and pastures as well.

The land is first leveled. The crops are then planted in rows which run up and down the slope, or, in case the slope is too steep, the rows run on gradually descending curves along the hillside. Small furrows are then made between the rows. The water is turned into these furrows from head



Fig. 14.—Furrow System of Irrigating Alfalfa. In the immediate foreground is a canvas dam in actual use.

Courtesy of Montana Experiment Station

ditches which are dammed at such intervals as to cause a certain number of furrows to be fed at one time. The head ditches are from 100 to 200 yards apart, depending upon the distance which water will flow in the furrows. In sandy land the water is not likely to flow more than a hundred yards, while in heavy soil it will flow twice that distance.

Trouble is often experienced in getting an even distribution of water to all the furrows. This is overcome in several ways:

- (1) By placing flumes along the head ditch and boring holes in the side for each furrow.
- (2) By setting little troughs in the ditch bank in such a way that each trough feeds the required amount of water to its respective ditch.
- (3) By so setting boards in the bank of the head ditch that the water flows over the board and into the furrows.

(4) Perhaps the most common method is by cutting notches in the ditch bank and then attending strictly to the work of keeping the proper amount of water running into the various furrows.

The first two methods are used for garden crops or when the amount of water is limited. The fourth method is the one generally used.

In Fig. 15 is shown a 10-acre field with a slight slope to the south.

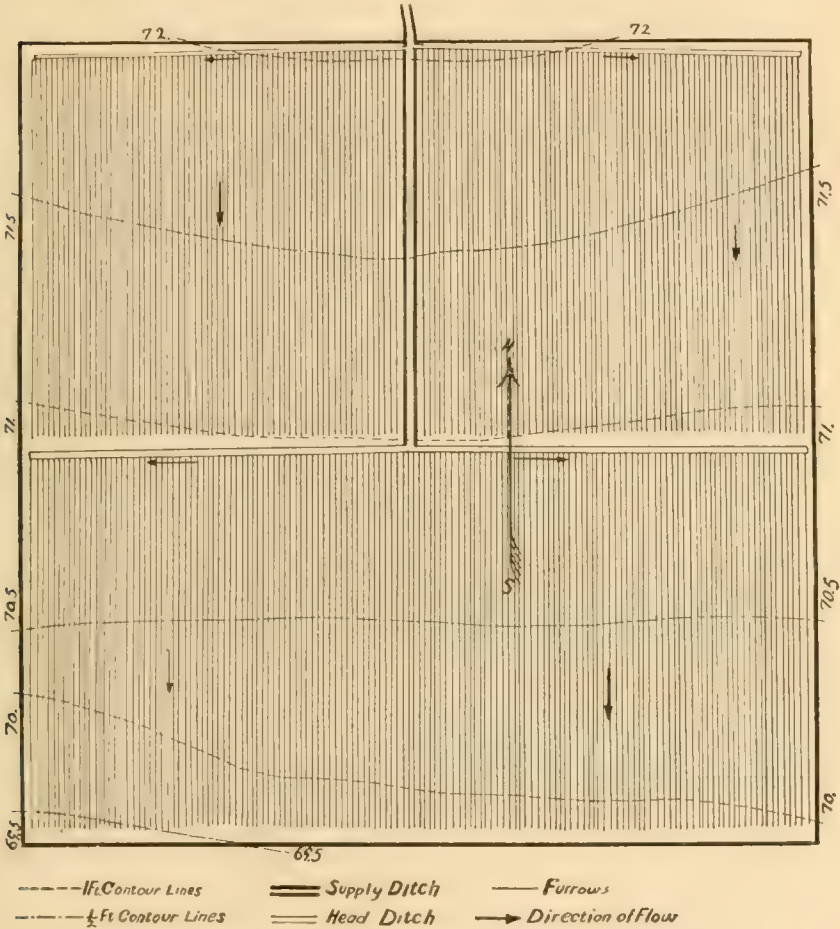

Fig. 15.—Method of Irrigating by Furrows.

Courtesy of the Montana Experiment Station

Water is delivered to the highest point in the field by the supply ditch. Head ditches are located across the north side and across the field near the middle. The crop to be irrigated is planted in rows which run in a north and south direction (up and down the slope).

In case of grains or hay crops, small furrows spaced about three to four feet apart, are opened from the upper head ditch to within one or two rods of the middle head ditch. Another set of furrows is opened from the

middle head ditch to within one or two rods of the lower side of the field. The furrows are made by means of a "corrugator." (See Fig. 16.)

A man can do more rapid work by making his own corrugator on the plan of a corn marker. Three 8-inch boards or planks about 15 feet long will make the top of a corrugator that will make 3-5 furrows at a time. The shoes are made of 2x8 planks about 5 feet long. Beveled cleats should be nailed on the sides of these shoes or runners to make them wider at the top. A wagon tongue is so fastened to the "corrugator" that the tongue is above the place where the furrow will be. The irrigator can place the

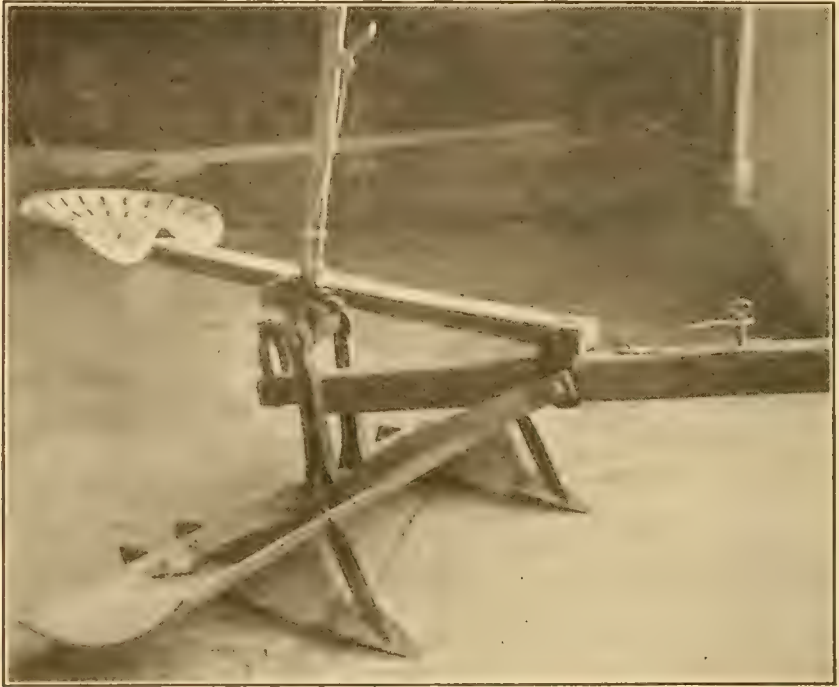

Fig. 16.—A Corrugator or Furrow Plow. This is used for making the small furrows or ditches when the furrow system of irrigation is used. The implement is adjustable both as to the depth and the spacing of the furrows.

Courtesy of the Montana Experiment Station

shoes as far apart as he desires and can make the furrows deeper by adding weights onto the frame. Work with this device is done immediately after the grain is sown and so the seeds are crowded to the sides of the furrow where they grow. When the last irrigation has been made the field is harrowed at right angles to the furrows to close the furrows.

In case a field is planted to some cultivated crop, such as beets, potatoes and corn, the rows should extend up and down the slope. The furrows are then opened between the rows by means of special shovels which may be attached to the cultivator.

In either of the above cases the irrigator simply turns a head of water

into the upper head ditch, and opens the outlets into as many furrows as he decides to irrigate. The water flows down the furrows and is absorbed by the soil between them.

After all the furrows leading from the upper head ditch have been irrigated, the water is turned into the lower head ditch and the lower part of the field is irrigated. In sandy soil the two head ditches would be necessary, while in the case of a clay soil the furrows would probably carry the water across the field from a single head ditch at the upper side.

Should the irrigator wish to flood a field which has been prepared for furrow irrigation, all that is necessary is to turn in a large head of water and put earthen dams in the furrows. This will enable him to do a very thorough job of flood irrigation.

Furrow irrigation is also adapted to orchard irrigation and for irrigating where the head of water is small. A small stream of water can be run down one or two furrows, that would be entirely too small for providing a large enough head for the flooding method.

Irrigation of Potatoes—The furrow system of irrigation has proved to be ideal for potatoes. The furrows between the rows of potatoes are

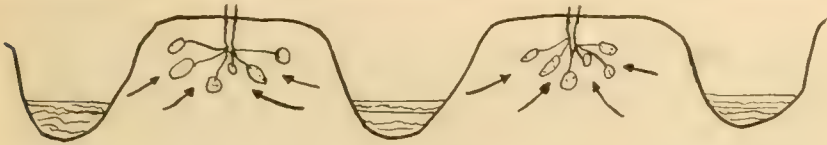

Section showing water in furrows between potato rows

Fig. 17.—Showing Furrow Method of Irrigating Potatoes. The arrows indicate the direction taken by the capillary water.

gradually deepened by each successive cultivation. The soil which is removed from the furrows is banked upon the rows in such a way that the tubers are formed above the bottom of the furrows. In this way the water wets the bottom and sides of the furrow, but it does not come in contact with the potatoes.

The moisture rises by capillary attraction (the same as oil rises in a lampwick) to the ridges in which the potatoes are growing. Thus a moist, not a wet, soil is provided for the potatoes to grow in. It is claimed that the potatoes grown under these conditions are superior in quality to those which grow in a very wet soil. Many potato diseases are partially controlled by this method of irrigation. Tubers formed in the moist, loose soil are inclined to be of a more nearly uniform shape.

CONCLUSION

Irrigation Details—The irrigator should be provided with thigh or hip rubber boots. In some of the warmer climates the boots are not necessary but as a rule it is poor policy to wade in the cold irrigation water without the protection of water-proof boots.

A light, round, pointed shovel is the most satisfactory tool which the irrigator can procure for making or removing dams and enlarging ditches.

Some irrigators use sheet steel dams for damming the water in laterals, but these are rather heavy and cumbersome. The most practical dam is the strip of canvas nailed onto two sharpened stakes. This dam is light and convenient to carry about and it is quickly set up in the lateral or the head ditch.

When irrigating it is well to have two or three extra canvas dams handy, as ditch banks are apt to break and dirt dams are likely to wash out. The canvas dam is very useful in quickly stopping such breaks or leaks.

The waste ditch should carry the water to where it can be used on some other field.

In furrow irrigation the furrows should be closed and cultivated when the irrigating season is over.



Fig. 18.—Potatoes Irrigated by the Furrow Method.

Courtesy of the Montana Experiment Station

Many crops are ruined by irrigating them too early. In general it is poor policy to irrigate before spring plowing. It is nearly always harmful to irrigate land before crops are planted. The crops should begin to shade the ground before the first irrigation. In case water is scarce during the irrigation season, some prefer to irrigate late in the fall or in the winter. The soil is well watered at this time and dry farming methods are used during the spring and summer.

It is better practice to use less water on the land and to cultivate the fields in such a way as to conserve the moisture, rather than to add large amounts of water without cultivation.

The excessive use of water tends to prevent the aeration of the soil, while the moderate use of water and frequent cultivation increase aeration and promote vigorous plant growth.

The amount of water to be applied and when to apply it, must be left to the judgment of the irrigator. The kind of soil and the crop will influence his judgment.

W. H. Olin says: "You cannot irrigate by the clock. You must put water on when the crops need it, and take it off when the want is supplied. Enough water is better than too much.

"Two irrigations are usually sufficient for small grains, grasses, potatoes, sugar beets and corn. The first crop of alfalfa or clover is made with one irrigation and the second crop likewise. Field or wrinkled peas are usually irrigated twice, but if sown early on fall plowed land one watering, after the crop is big enough to shade the land, will make a good crop of fine quality. Four or five irrigations are required for young orchards. Melons and sugar beets should have no water for some time previous to the maturing of the crop. Alfalfa, clover, and timothy should have no water during the maturing of the seed, if seed is desired. Some foresight is required in using the water at your command, so that sections of the land may be irrigated consecutively for economy both of water and labor in applying it. Above all, watch your work. Each little stream needs attention."

BOOK VII
FARM BUILDINGS

FARM BUILDINGS

CHAPTER I

THE FARMSTEAD

- I. THE SITE. II. ARRANGEMENT OF BUILDINGS—RECTANGULAR SYSTEM. III. PLACING INDIVIDUAL BUILDINGS. IV. CONCLUSION.

Every farmer should look upon his farm as a factory, an industrial plant, which takes in food stuffs and converts them into butter or eggs or beef or bacon, as the case may be. He should look upon his barn and poultry house and piggery not merely as places to put animals into, but as units in his industrial plant; the foundry, and the casting rooms and the finishing rooms of his business. He should arrange his buildings so as to secure the greatest economy of time and space, for time and space are just as valuable on the farm as they are in the manufacturing city. He should give them light and ventilation and attractiveness, not as a matter of sentiment, but as a matter of good business. Above all, he should get the greatest possible efficiency out of his equipment, for efficiency is the key to success, be it in the manufacturing or the farming world.

THE SITE

The selection of a good site is important, for when it is once established it is almost never changed. Occasionally, after a destructive fire or cyclone, it may be advantageous to change the whole homestead to a different quarter, but in the ordinary course of events, the farmstead cannot be moved.

Although the selection of a building site depends upon the nature of each particular farm, there are a few general rules which may aid the farmer in selection.

The ideal site for a farmstead is a gentle, southern slope. Unfortunately, all good slopes cannot be to the south, but there is a good slope on nearly every farm, and it should be taken advantage of in building. Such a slope gives good drainage both of air and water, and makes easy hauling to and from the barn. It is a great mistake to locate the farm buildings in the bottom of a valley or in a pocket. The cold air flows down across the hillside and gathers in the bottom of the valley, causing destructive frosts. It is a still greater mistake, however, to build the farmstead on top of a high hill. The drainage is doubtless

excellent, but the hauling to and from the barn becomes an unbearable task. A good slope, with air and water drainage, is the best site in a hill country.

On the plains, buildings should be placed on the highest convenient elevation to give good drainage. If this cannot be done, the foundations of all buildings should be built high, and the earth banked up around them. Neglect in this matter results in a mud hole about the buildings in rainy weather—a condition which is not only unsightly but unsanitary.

It is not necessary to build as close to the main road as possible. The fraction of a mile to town gained in this manner can never compensate the farmer for the loss of a sanitary or a beautiful farm site. Indeed, it is quite immaterial where the farmstead is located on the farm if it have the three requirements for a good site—sanitation, convenience, and beauty.

THE ARRANGEMENT OF BUILDINGS

Too much care cannot be taken in the arrangement of farm buildings. The walking of an unnecessary three hundred feet a day to the poultry house means a forty-mile walk every year, and the wasting of fifteen minutes twice a day in going to and from the pig pen means the loss of eighteen ten-hour days in every year. It is obvious that when the farm buildings are carelessly scattered all over the farm, the hired man may easily spend months of needless labor in doing the chores alone.

A good building arrangement, then, should abolish all useless labor. The most convenient of all building arrangements, as can be geometrically proved, would be the circle. But for economical, if not for architectural reasons, it is quite out of the question to build circular farmsteads. So we must fall back on our next most convenient arrangement, the square.

There are several points about the square or rectangular system which make it the most practical. The buildings can be placed in regular order, so that the hired man can go from one building to the next in doing the chores, without any extra steps. With the corn crib and water trough in the center of the square, no building is far away from feed and water supplies. By grouping the buildings in a square with as many fields as possible opening directly onto it, the most economical use of time and energy is assured.

Some years ago the prevalent type of farmhouse in New England was the "L" or "T" type, which began with the farmhouse and continued by means of alleys and passages through the stages of dairy barn and poultry house to the pig pen. The whole farmstead was practically under one roof, with a single feed room, and one or two feed alleys serving for all the barns. It was perhaps the most economical arrangement ever devised, but it had one fault. Whenever one of the buildings

was struck by lightning, the whole establishment promptly burned down, and instead of losing one barn, the farmer lost all. Perhaps when farmsteads are built of steel and concrete it will be practical, but not until then.

Meanwhile we have learned a lesson, namely, to place all buildings in the quadrangle from 100 to 150 feet apart to prevent the spread of fire.

PLACING OF INDIVIDUAL BUILDINGS

A good way to lay out a new farmstead or rebuild an old one is to make a diagram of some farmstead you are acquainted with. Then take a lead pencil and trace on it the route taken by the hired man every day for a week. The unnecessary steps that he takes will stand out with surprising distinctness, and new arrangements will suggest themselves automatically.

The farmhouse should always be the predominant building of the group. It should have first choice of location and be the key of the square. It should have room for a yard and a view across the neighboring hills. It should have trees to shade it and a lawn to grace it. If one has any personality at all, the home is the place to bring it out. Is it sound business to keep the boys on the farm? Then it is sound business to make the farmhouse attractive, for the one way to drive them to the city is to surround an unlovely home with pig pens, and build the barn between it and the road.

First, then, the farmhouse should be located. Then the rectangle should be built up back of it, according to the number of buildings desired. The barns and hog houses should form the square proper, for these buildings require the most care and take up the most of the farmer's time. Whenever possible, all barns should be placed to form windbreaks for the pens. They should also be placed so that the prevailing winds will carry the odors away from the house. As a rule, no barn should be built closer than 200 feet to the farmhouse. Poultry houses should be placed on the side of the square nearest to the house. There is less odor from poultry houses than from the barns and the women often take care of the flock. It is usually possible to have a single road running from the barnyard, which divides, one part going out past the house to the main road, and the other going to the fields. The watering trough and implement shed can be conveniently placed at this junction, as can a carriage house. The shop and corn crib, however, should always be placed in the center of the rectangle, with the artesian well. All hospital buildings must be placed at a considerable distance from the rectangle.

To sum up, the location for the farmstead must have good drainage, be accessible, and have a good water supply. Given these essentials that farm is best arranged in which work can be performed with the least possible waste of time and labor.



Fig. 1.—First Prize Model Farmhouse, by Hewitt & Brown, Architects, Minneapolis.
Courtesy of the Minnesota State Art Society

CHAPTER II.

THE FARMHOUSE

I. INTRODUCTION. II. LOCATION. III. STYLE OF ARCHITECTURE. IV. EXTERIOR FINISH.
V. INTERIOR REQUIREMENTS. VI. PLANS. VII. CONSTRUCTION.

Introduction—The farmer has spent much time and money in promoting his agricultural work. He has built good barns for his cattle. He has paid large sums of money for modern machinery. Yet his house rarely contains any labor-saving device, and is sometimes as bleak and inconvenient as the log cabin of his grandfather.

When pressed, many farmers fall back upon the argument that a good barn is a good investment, while a good home is a luxury. That is illogical. What is the greatest resource on the farm? The fields? No, because land is worth nothing if left to itself. The live stock? Assuredly not, for without the necessary care and feeding, live stock is worthless. The greatest resource on the farm is the farmer and his family, for without them there could be no farms.

How much more important, then, is it that the farmer should provide adequate means for the comfort and protection of himself and his family? We may look upon it in a purely business light. Convenience about the farm means increased efficiency in labor. This is particularly true of a convenient farmhouse with labor-saving devices. Or we can take the

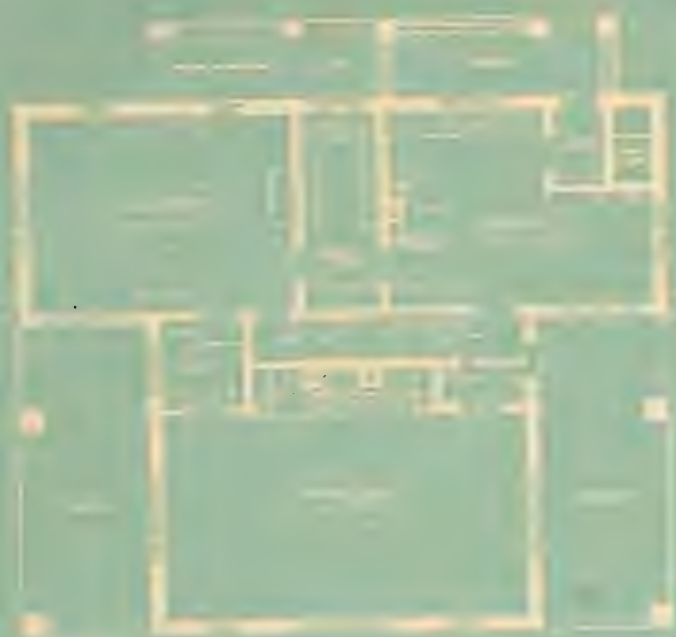

Fig. 1. First floor of the "Palace of the Republic" in Bucharest.

Fig. 2. Second floor of the "Palace of the Republic" in Bucharest.



Fig. 3.

Fig. 4.



Fig. 5.

Fig. 6.

more esthetic view-point. Modern conveniences and beautiful surroundings lend contentment and cheer to farm life. And contentment is the key to efficiency. In either case the conclusion is the same: a modern house, carefully and artistically designed, and fitted with every convenience, is the farmer's best investment.

Location—The farmhouse cannot be discussed intelligently apart from its surroundings. The best place for the farmhouse depends on the location of the barns and other buildings. The position of all of these in reference to convenience, air, sunlight, roadway, and view should be carefully considered. The farmhouse should be away from the other buildings, yet it should definitely be a part of the entire group. Its location should have prominence and dignity, and it should show clearly that it is the head and ruler of the farmstead. If a new farm is being developed, plan out the whole farm scheme, uniting lands, barn and dwelling into a workable system before any building is undertaken. Hit and miss methods always result in inconvenience, unsightliness and waste of money. Even if a beginning must be made in a small way, have the completed plan worked out at first and add improvements gradually. If one has an old farm to replan, read Chapter II. in Book XI. and lay out the entire scheme before a shingle is torn off or a fence pulled down. Remember that the farmhouse is not to be planned as a thing apart from barns and outbuildings. All must form a unit with the farmhouse the presiding individual.

Style of Architecture—In planning a city house, one can generally select the style that pleases one and build a dwelling that will look well enough, facing a straight paved street and with no background save the walls of other houses. In the country the problem is more complex and the chance of obtaining pleasing effects much greater. The farmhouse has a natural setting, either hills, or woodland, or plain, which the city house lacks; and if it is planned to harmonize with its surroundings it becomes a part of the picture, and a source of permanent satisfaction to its owners.

The secret of good architecture is fitting the farmhouse into the surrounding landscape. Expensive houses have been built and then their owners have been dissatisfied with them; they do not know quite why. Some other house built for less money frequently, is more pleasing to the glance, more favorably commented on by the passerby. The difference in all probability is that one house looms up from its neighborhood, prominent and out of keeping, while the other seems to fit right in and to complete the picture.

The farmhouse built in the plains should reproduce the long level lines of the plains—the flat roof, one-story-and-a-half construction, and long gables typified by the American bungalow.

In forested regions, it will partake of the lines of the forest, tall,

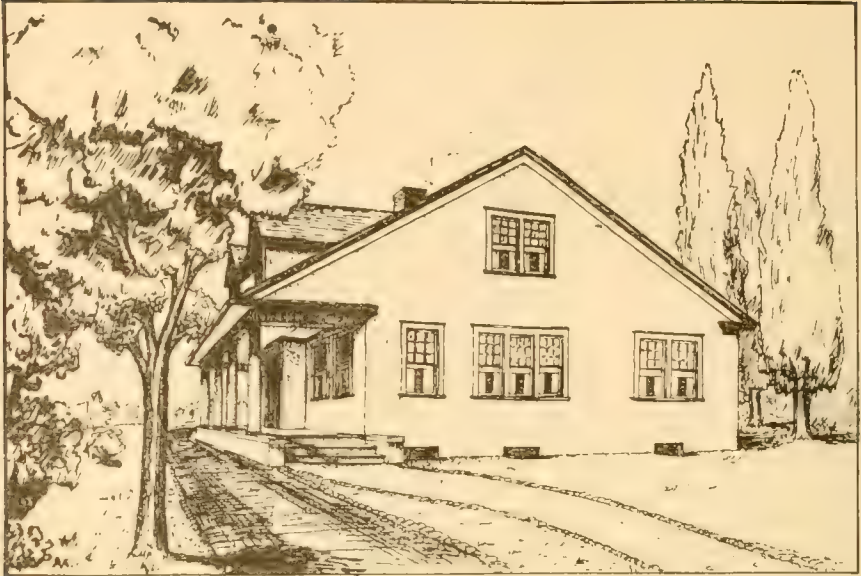

ARTHUR L. DEVAR.
ST PAUL

Fig. 2.—A Farmhouse Built for the Plains.

Courtesy of the Minnesota State Art Society

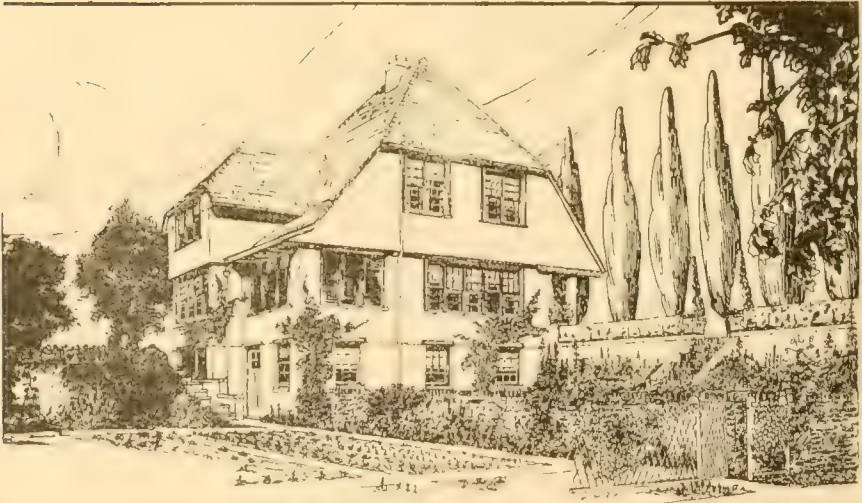

HERBERT A. SULLWOLD
ARCHITECT ST PAUL

Fig. 3.—This House would look well in Wooded Country.

Courtesy of the Minnesota State Art Society

narrow, and angular, with high narrow windows and the steep roofs of the Victorian age.

In hilly regions it will partake of both types, blocky, rather steep roofed, with square windows and a general appearance of square rather than oblong construction. This type of a building seems to belong with the hills better than any other.

Exterior Finish — In general the exterior should be plain. Fancy turrets and old-fashioned "gingerbread work" are undignified and unbeautiful. The house should rely on its lines and color for its attractiveness. Any attempt at adornment is almost sure to cheapen the effect. The color should be selected with great care. The old white farmhouse with green shutters is still very beautiful if set in a garden and shaded by trees. Quiet colors should always be chosen. Greys and browns, greens and tans in the more subdued shades are dignified and will look well long after the brilliantly painted house, which was an offense from the first, has become shabby. Houses built of concrete, plaster and brick in their natural shades are always satisfactory in color.

Even more important than the exterior of the house is the interior; a charming interior will make one forget bleakness outside, and people can live quite comfortably within shabby walls if the inner ones are homelike.

Interior Requirements — Again the planning of the country house is very different from the city. The country house has many needs as a factory and storeroom that the city house never has to meet. The farmhouse must provide room for these greater activities yet neither living nor sleeping quarters should be cramped and the whole must be convenient for the worker. Broadly speaking the house can be separated into three divisions, living area, working area, and sleeping area. The first refers to the living-room, dining-room, office, porches and library; the second to the kitchen, pantry, laundry, hall and stairs; the third includes the sleeping rooms and bath. The living area should combine comfort and spaciousness, the working area must be compact and convenient, the sleeping area must have privacy. All rational house planning must be based on these principles.

Plans — The plans shown in this chapter were all drawn for a competition held by the Minnesota State Art Society in 1913. The Society felt the need of more comfortable and convenient farm houses and offered six prizes for plans submitted. In order that they should be completely practical the specifications were fixed by farmers and the judges were a farmer, a teacher of home economics, and an architect. The house was to have 10 rooms, the cost was estimated at \$3500, and the location was assumed to be a partly wooded knoll near a road. The plans were to meet the following conditions:

"There is a basement under the entire house, providing space for heat-

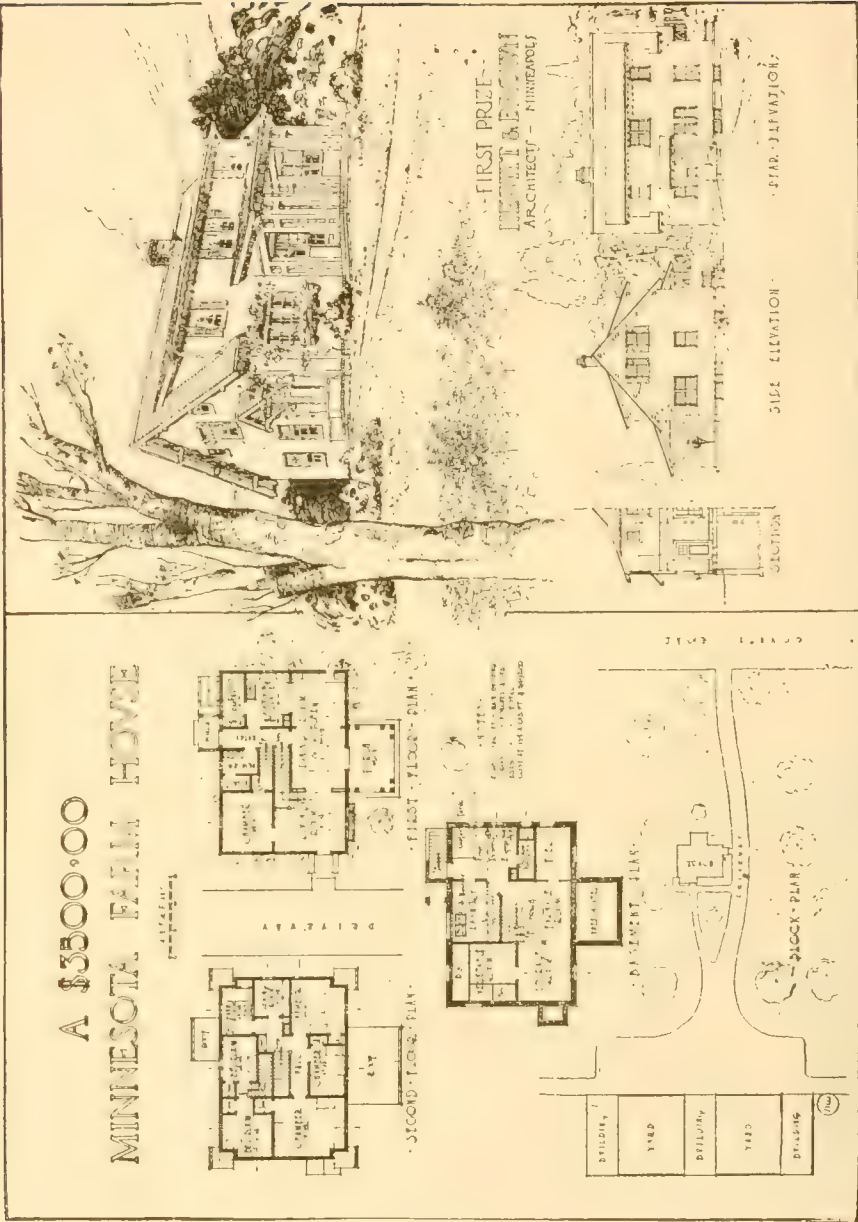

FIG. 1.—FIRST PRIZE MODEL FARMHOUSE. Full sized working plans and replica of the original drawing may be obtained for a nominal cost by writing to the Minnesota State Art Society, Minneapolis, Minn.

ing, water supply, and lighting apparatus and for storage rooms. On the first floor is a living-room, a bed-room, a dining-room or a dining-room and kitchen combined, a pantry with space for refrigerator, and a wash-room and closet for the farm help. On the second floor there are five bed-rooms, a bath-room, and a small sewing-room. The two bed-rooms for the use of the farm help are separate from the others, being

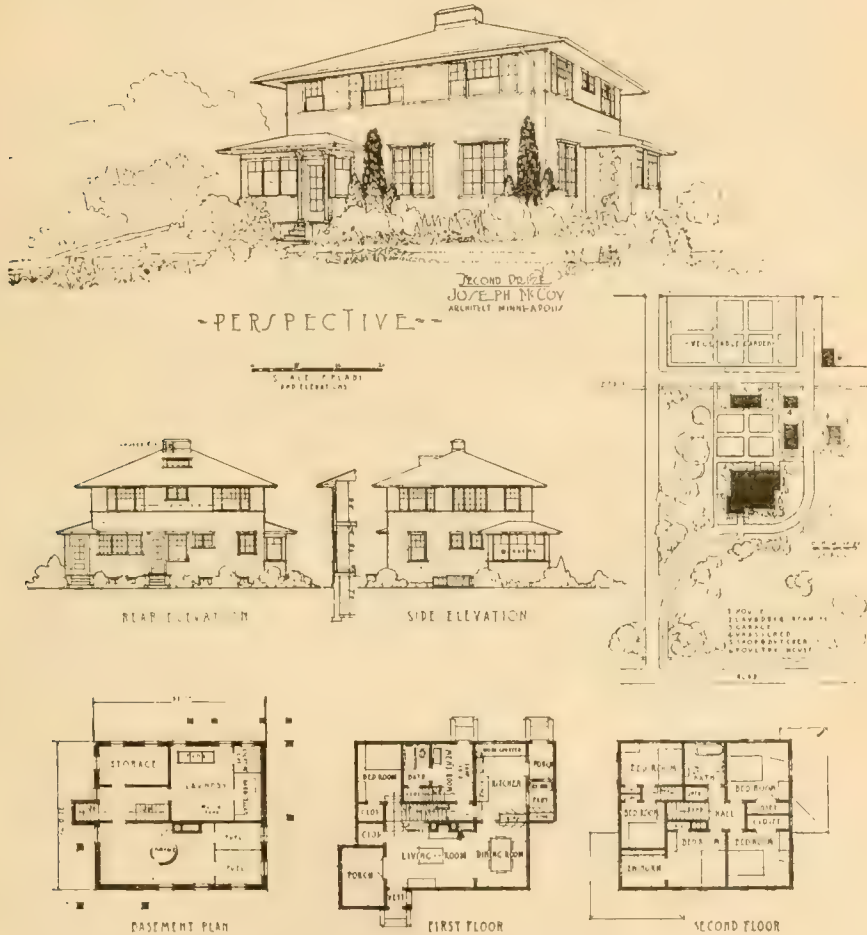

Fig. 5.—A House Designed for the Plains of the Middle West.

Courtesy of the Minnesota State Art Society

approached by a special stairway leading from the wash-room on the first floor. The methods of heating and lighting, and the character of the plumbing are determined by the limit of cost. The house is figured on a basis of 15 cents to the cubic foot of space, with the porches estimated at one-fourth of the total cubage."

Because of its compactness and economy in building, the square type

of farmhouse is to be preferred to all others. Second to this is the L-type, which readily provides for the separation of rooms for the hired help.

The house shown in Figs. 1 and 4, winner of the first prize in the contest, is a square plaster house designed for rolling country. It is compact, rather steep-roofed, and in every way conforms with the suggestions previously made, that a building for hilly country should be of the blocky type.

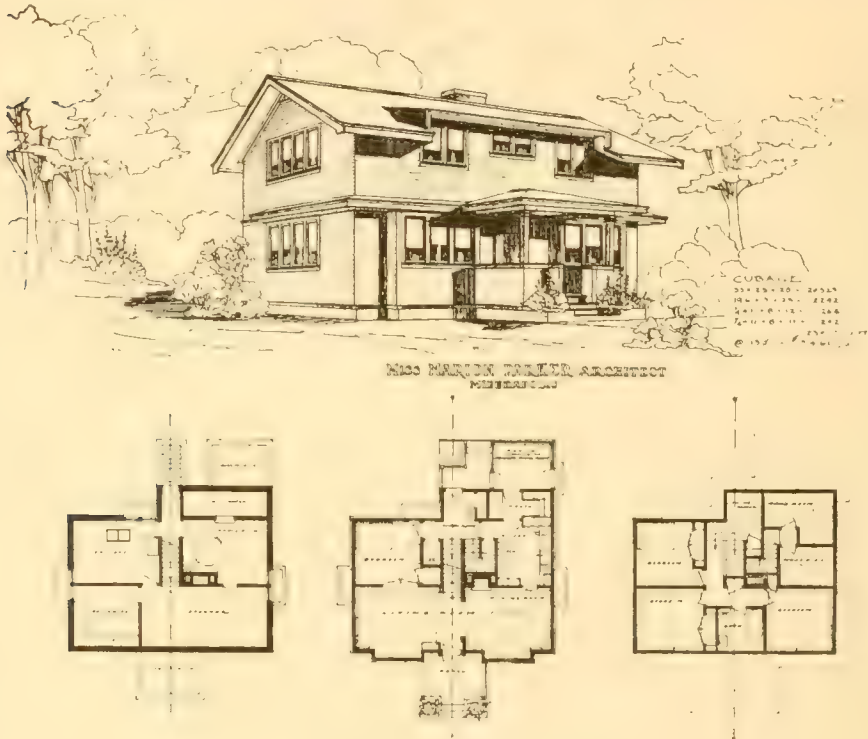

Fig. 6.—A House in Wood and Plaster.

Courtesy of the Minnesota State Art Society

The basement provides for a furnace room, laundry, storage room and vegetable room. Each has the advantage of being separated from the others so that the contents of each may be protected from dust, heat, light or dampness as they may require. Any housewife who has known the convenience of a separate laundry will not be driven back to the discomfort of cooking and washing over the same fire.

On the first floor, the most noticeable convenience is the wash-room across the hall from the kitchen. The men do not come into the kitchen to wash their hands in this house — they go to the wash-room, as they should. Another convenience is the connected kitchen and dining-room, by which the nuisance of serving a meal through several doorways is

avoided. A third advantage is the almost complete isolation of the living-room and first floor bed-room, by means of which the farmer's family obtains greater privacy. The wide doors between the living and dining-room give a pleasant effect of roominess.

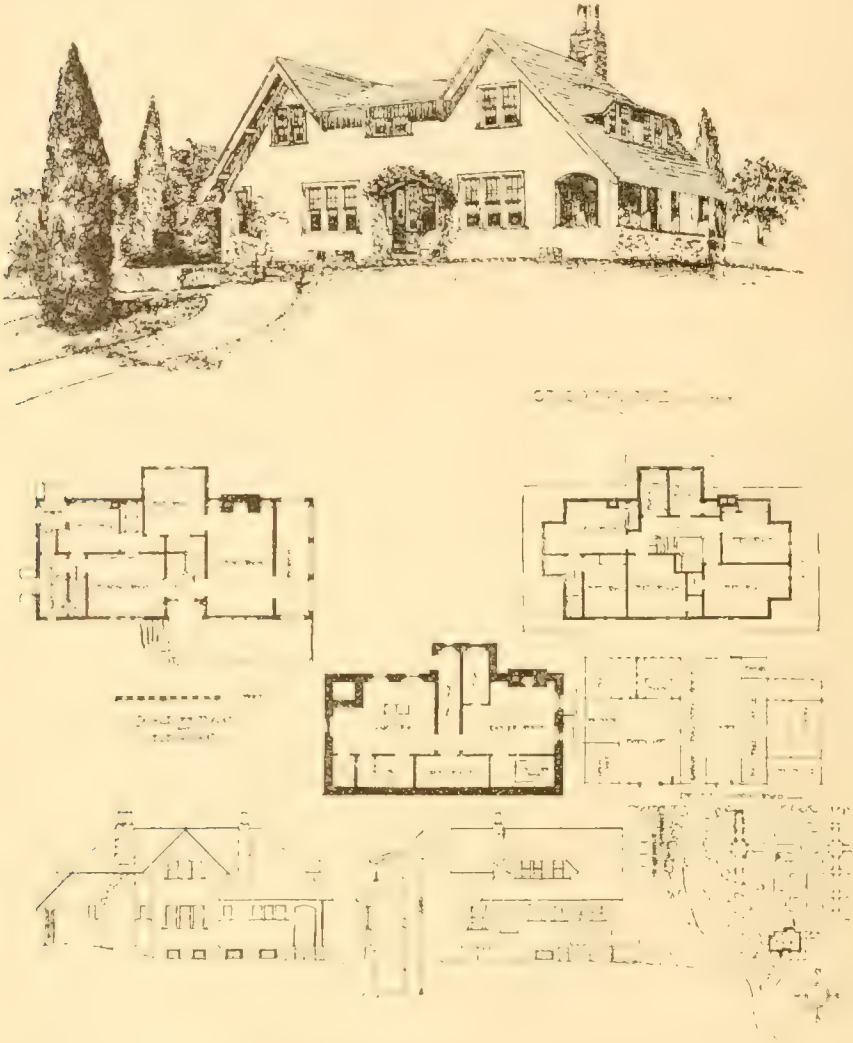

Fig. 8.—The Double Gables Give an Effect of Roominess and Comfort.
Courtesy of the Minnesota State Art Society

On the second floor two stairways will be noticed. The first leads into the main hall upstairs. The second leads into the hired men's bedrooms. In this way the hired men's rooms are completely separated from those of the farmer and his family. Note also, the grouping of rooms about a single short hall. This is the most economical arrangement both as regards space and labor.

Fig. 5 shows a house designed for the level plains of the middle West. Note that its longest lines are horizontal. The roof is very low. The windows are placed together, so that their longest dimensions are horizontal. The porches have the same general lines.

In arrangement this house is much the same as the first. There is the same wash-room on the first floor, and across the hall from the kitchen. The kitchen is not quite so intimately joined to the dining-room, and the parlor, or living-room, is a little too closely connected with the dining-room. But again, we get the separate back stairway and the isolation of the men's bed-rooms on the second floor.

Fig. 6 is an artistic little house in wood and plaster. The most striking point about it is the way in which all the rooms on the first floor open into one another. This would make the house a very acceptable one for any of our southern states, but would be rather hard to heat in our northern winters. The wide doors between the living-room and bed-room are not generally practicable. Here also the upstairs rooms are grouped around the central hall and the men's bed-rooms are entirely separate with a separate stairway.

The L-type house of plaster and shingles shown in Fig. 8 resembles the English style of architecture of which the chimneys are typical. The plans indicate that it is rather well arranged.

Broad lines always give an effect of comfort and spaciousness. The house shown in Fig. 8 would fit well into almost any landscape. It is conveniently arranged yet with complete separation of the living-room from the kitchen.

Construction—Wood and plaster are favorite materials for farmhouse construction. The distance the farmer has to haul cement, sand and gravel often renders it too expensive for extensive use in country homes, but it is probable that as the price of wood goes up, more and more country houses will be built of concrete. Brick particularly in combinations of the yellow and brown shades, is being extensively used on the more pretentious country places. A house well built of good brick is practically everlasting. It does not require painting and the cost of maintenance is low. A brick house does not show to good advantage, however, unless surrounded by rather extensive grounds, and the cost of the brick is usually prohibitive. Wooden frame houses seem to be the best for the average farm. They are easily constructed, and if put up properly, their maintenance cost is slight. While most of the plans give either plaster or cement for the walls, they can be readily duplicated in wood.

In general, the rules which apply to building the barn or any of the other buildings apply with equal force to the farmhouse. Only the best of lumber should go into its construction. Everything should be well and carefully done. It pays to build well. A convenient and artistic farm-

house adds to the contentment of the family and the hired help. It lends distinction to the place and gives a personal touch to the farm. It may increase its selling value twenty-five per cent. It costs but little more to secure good plans and to build well than it does to build carelessly and without thought of the modern conveniences. The farmer's family is his greatest resource, and the returns from money spent on them is beyond estimate.

CHAPTER III.

THE DAIRY BARN.

I. INTRODUCTION. II. BARN PLANS—WELL ARRANGED BARN — INCONVENIENT BARN — CONVENIENT, SANITARY BARN. III. DETAILS OF CONSTRUCTION—FLOOR—CEILINGS—VENTILATION BY KING SYSTEM—LIGHTING—STALLS—BULL PEN—WATER SUPPLY—MANURE PITS. IV. THE ROUND DAIRY BARN—ADVANTAGES OF—DETAILS OF CONSTRUCTION—PLATES—FLOORS—VENTILATION—LIGHTING—STALLS.

There are two essentials which must be borne in mind when building a dairy barn; it must be sanitary, and it must be convenient. The first and most important reason for sanitation is that milk is one of the best media for bacteria. There is scarcely a disease germ that will not live and multiply in milk, and a dirty barn is a favorite hiding place for germs. When contaminated milk is sold to customers, an epidemic follows. The farmer will not have to think twice to know that this is as bad for his business as it is good for the doctor's. The second great reason for sanitation affects the dairy herd itself. With thirty or forty cows confined in a dirty barn, it becomes impossible to stop the ravages of a contagious disease among them.

Every minute that milk is kept in the barn detracts from its quality. It must be milked and sold as quickly as possible. Too many of our dairy barns are so arranged that half the morning is taken up in milking, and the rest of the day in feeding and cleaning. There are so many other things to be done on a dairy farm that the farmer cannot afford to waste very many hours on simple tasks like these.

One of the most convenient barns has two long rows of stalls, with a central manure alley, and feed alleys on either side.

Such a barn is shown in Fig. 1. With the silo opening upon one of the feed alleys, and a hay chute opening down into each of them, the feeding of the entire herd is a simple operation. For greater convenience in handling grain and silage, feed carriers with a track extending into the mixing room and to the silo may be provided. In such a barn, two men can make a single continuous operation out of cleaning and feeding.

Attention is called to the detail of the curb roof on this plate. The failure of the curb roof can always be traced to incorrect or insufficient bracing. This shows the proper method of bracing the small curb roof.

Contrast the barn in Fig. 2 with that in Fig. 1. Here the milkers must go into alley No. 1, come out of that and go into alley No. 2, and so on

both in feeding and milking, until twice as many steps have been taken to perform each operation as were needed in the first barn. Note the corners in the mangers and gutters where dust and dirt must accumulate in spite of everything one can do. Note also the number of turns which the manure carrier must make in operation. This means expense in installation and trouble at the turns. Both barns have practically the same capacity—thirty cows—but the work involved in milking,

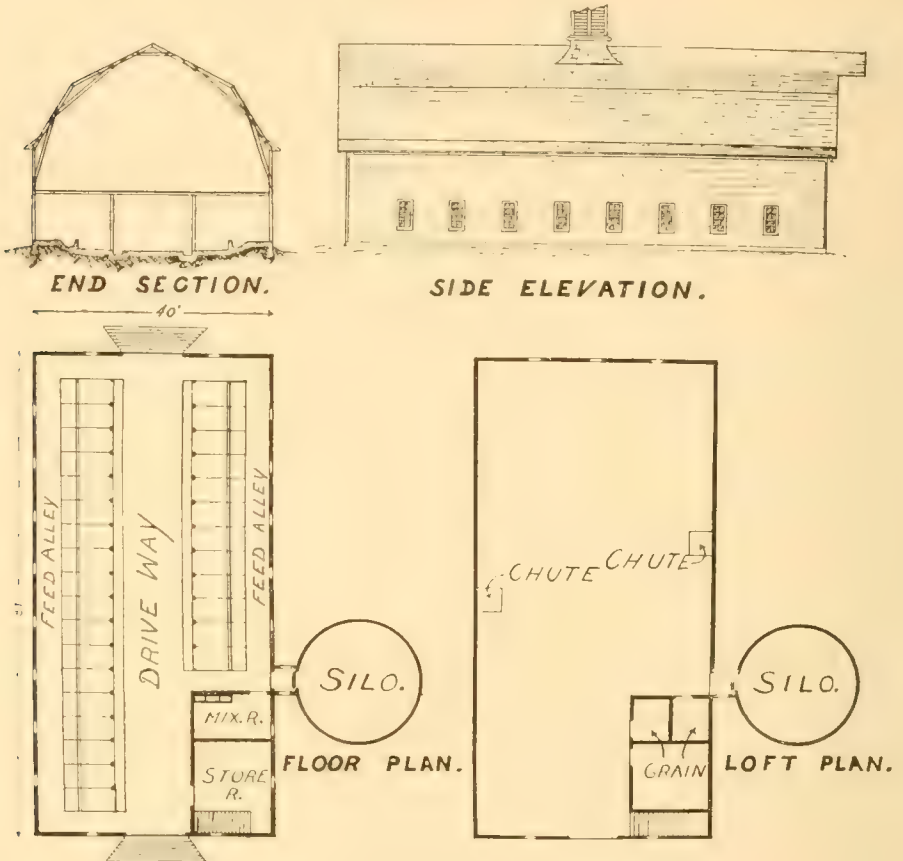

Fig. 1.—Dairy Barn.

Courtesy of the North Dakota Experiment Station

cleaning and feeding must be at least twice as great in No. 2 as in No. 1.

Figure 3 shows a very convenient and sanitary barn. With a barn of this plan, properly constructed, the work of cleaning is reduced to a minimum. It is open throughout its entire length, permitting a free circulation of air and an abundance of sunlight. The location of the calf pen and box stalls on either side of the main driveway and feed alley shows good arrangement, as it is convenient in feeding and care. The mixing room is where it should be—as close to the silo as it is possible

to place it. This plan shows how the grain bins should be located above the mixing room, with hoppers through the floor. The silo may be just as conveniently placed at the end of the barn if desired.

A dairy barn, however, must be something more than a good plan. It must be so constructed that it may be kept sanitary at all times.

Floors — One of the most sanitary floors is the cement floor. Wooden floors, however well constructed, are sure to become soaked with manure sooner or later. This is especially true of temporary wooden floors laid over concrete. The urine has no chance to run off, and the

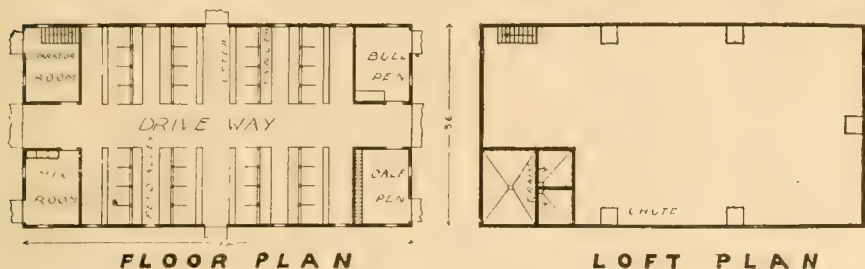
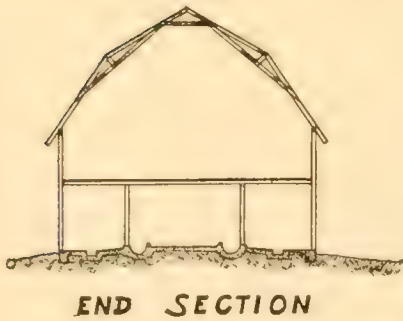
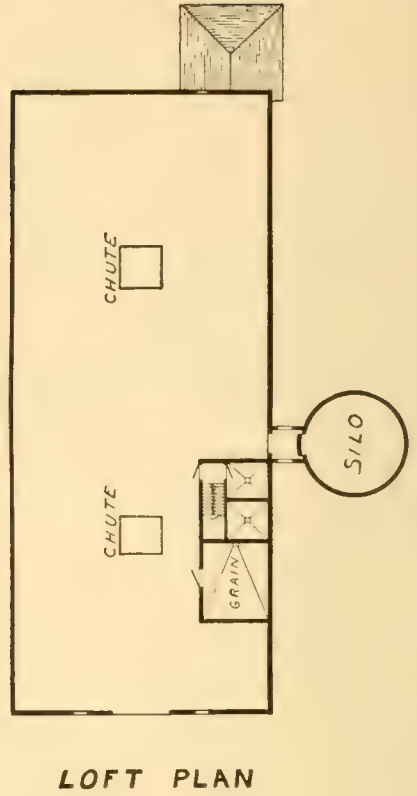
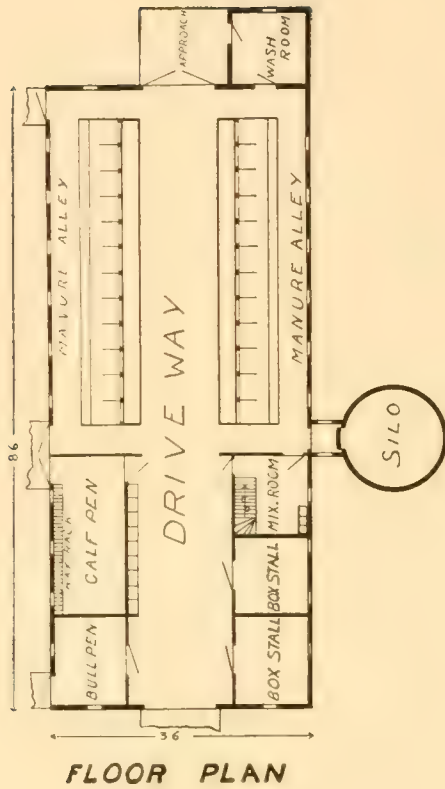

Fig. No. 2

Courtesy of the North Dakota Experiment Station

wood becomes soaked in it after the first week and remains soaked until it rots out or becomes so offensive that it has to be removed. Needless to say such a floor is far from sanitary. Whenever wood floors are laid over concrete in the stalls, they must be removed and cleaned at least once a week.

On the other hand, a good concrete floor cannot soak up urine. There are no cracks in it to fill with manure. A slight slope is all that is required for drainage, and a stream of water will clean it thoroughly. The only objection which may be raised to the concrete floor is its coldness when not placed on well drained soil.



DAIRY BARN

SCALE IN FEET
0 5 10

Fig. 3

Courtesy of the North Dakota Experiment Station

In laying a concrete floor the following precautions should be observed:

1. The feed alleys should be at least eight feet wide, and should always be laid higher than the stall floors to enable refuse to be swept through to the cleaning alley.

2. There should never be more than a 1-inch slope to the 5-foot length of the stall. More is unnecessary, and may be dangerous, as concrete is rather slippery when wet.

3. The floors of all stalls should be grooved at 5-inch intervals, either lengthwise or crosswise, or should be roughened up with a steel broom before the concrete has hardened.

4. The gutters should be at least 16 inches wide by 10 deep, and need not have a slope of more than an inch in 35 feet.

5. The manure alleys should be lower than the floors of the stalls, and should never be less than three feet wide to facilitate cleaning.

The construction of the stable floor, although not difficult, requires care. It is simply a matter of laying the courses at different heights and templating the stalls and gutter to the required slope. Any competent mason can lay one, and the cost is not much greater than wood in the long run.

There is little danger of rheumatism on concrete floors. They require more bedding than wooden floors, but when this is supplied the animals do not catch cold or have rheumatism as has been popularly supposed. On the contrary, the cleanliness of the concrete floor greatly reduces the disease risk in dairy cows.

A very satisfactory floor for a dairy barn may be made from creosote blocks like those used for street paving, except that the blocks need not be so thick. This type of floor overcomes all of the objections to concrete floors and is quite reasonable in cost.

Ceilings—All ceilings should be made of tongued and grooved flooring of good quality southern pine, or some durable and inexpensive lumber. It is not enough to lay a tight floor to the haymow; there must also be a tight ceiling above the cows. It is imperative that dust be kept from continually sifting down from the haymow. This dust falls into the pails at milking time, and every particle carries a rider of some sort of germ. They may not be disease germs, and then again they may. In either case they lower the quality of the milk.

For this reason all flues and hay chutes should be made tight. They may be lined with paper, or built with flooring. In any case they should extend through to the floor.

VENTILATION BY THE KING SYSTEM

A cow confined in a stable is never under perfectly normal conditions. The best that we can do to insure maximum production is to

imitate pasture conditions as closely as may be and keep the animal contented and comfortable.

The first and most difficult of the natural conditions to be maintained is the proper circulation of air. In the fields this circulation is perfect. Carbon dioxide is diffused through the air as quickly as it is formed. Breezes keep the air continually in motion. When we take the cow

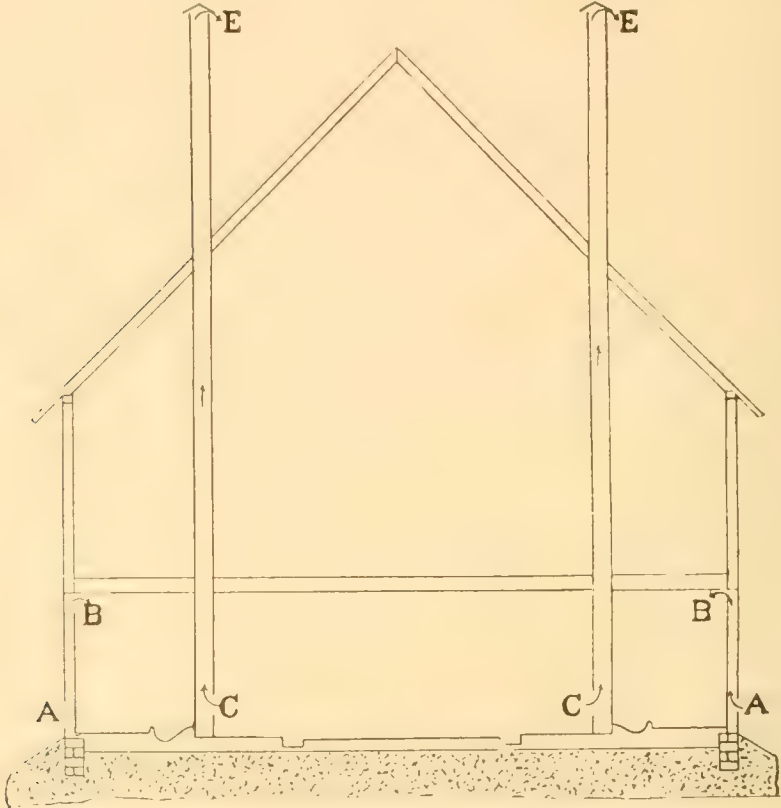

Fig. 4.—Best method of ventilating an ordinary stable. The intake flues, constructed in the side wall, or if stone, brick or concrete is used, as in Figs. 9, 10, 11. The ventilator flues, CE, will take up space occupied by two cows, but they will be found more efficient than a single flue. They should have their lower openings at or near the floor level and rise 2 or 3 feet above the ridge of the roof, or an adjoining roof. These flues may be constructed as shown in Fig. 12, or lined with very light galvanized iron. Caps may be placed over these flues or cowls as shown in Fig. 6. The latter will be found more satisfactory.

Courtesy of the Wisconsin Experiment Station

out of this perfect circulation and place her in a barn without any ventilation, her vitality is lowered and the result may be bovine tuberculosis. It is essential, therefore, that a good ventilating system be installed in every dairy barn.

The most perfect of these is the King system which is based upon the well-known physical law that warm air rises and cold air falls. It

consists of a number of inlet flues, or draughts, and one or two outlet flues, which are nothing more or less than chimneys.

In Fig. 4 we have a working model of the King ventilation system. AB are inlet flues, of which there should be at least ten in a good sized dairy barn. CE are the outlet flues. The course of the air is indicated by the arrows.

The cold air, which sinks to the floor of the barn, is drawn in through

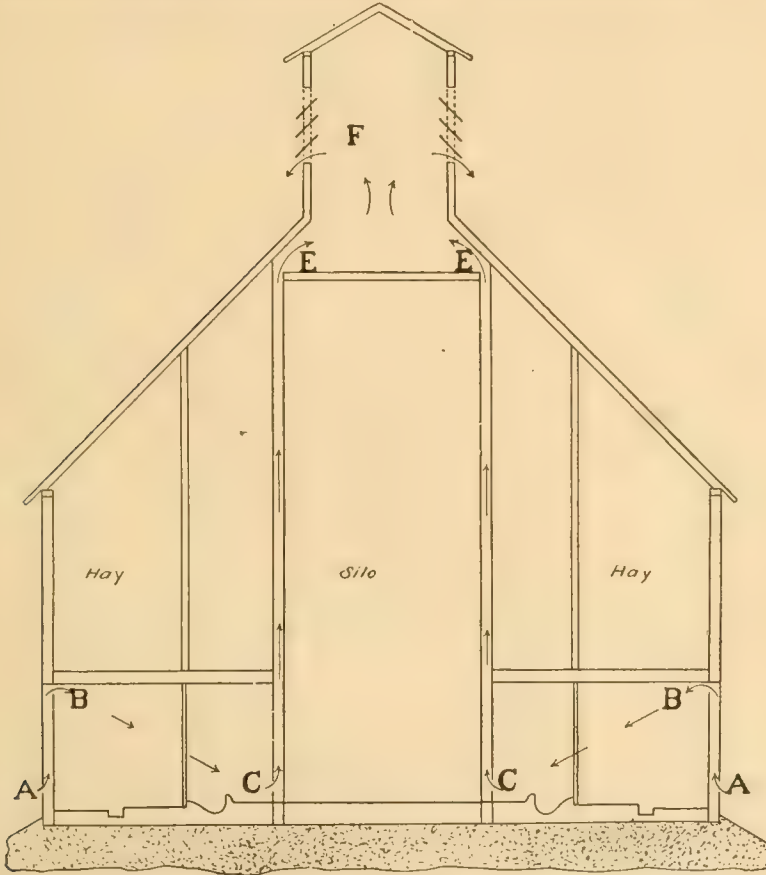

Fig. 5.—Ventilating a barn having a silo at or near the center. The fresh air enters at AB, and finds its way to the foul-air shaft CE, passing out through the cupola F. The ventilators, CE, are spaces in the walls around the silo.

Courtesy of the Wisconsin Experiment Station

the opening at C, and being warmer than the outside air, rises. This loss sucks in the outer air through AB, where it enters the room near the ceiling. Now, the warmest part of the room is at the ceiling, and the cold air coming in there is warmed by contact with the warm air there before it settles down over the animals. This keeps the stable warm, prevents draughts, and furnishes a good circulation of air at the same time.

Contrary to the general opinion carbon dioxide does not rise to the ceiling, but sinks to the floor instead. So the outlet near the floor serves the double purpose of drawing off the carbon dioxide and the coldest air at the same time.

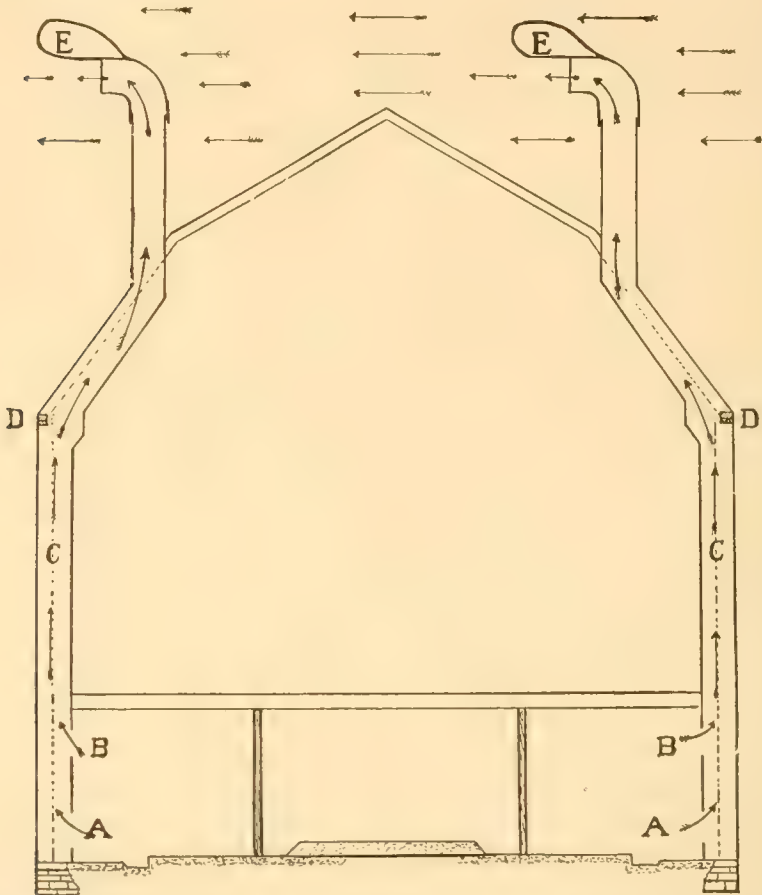

Fig. 6.—Method of constructing foul-air flues in a barn in order that they may pass through the roof at the gambrel or near the purline plate. This method may be desirable in barns where large quantities of hay are stored leaving more room from the purline plate to the ridge for the hay carrier to pass back and forth. Installing such flues usually requires the placing of the cowl, E, at the top of each flue. These cowls revolve with the wind as it changes from one direction to another and prevent its entering one flue, passing downward and up the other at the opposite side of the stable. The flue must be enlarged at D. Inlets for fresh air may be constructed in the sidewalls.

Courtesy of the Wisconsin Experiment Station

There are a number of variations to the King system, all of which are practical.

Fig. 5 shows the method of running the outlet flues up beside the silo in a round barn.

Fig. 6 shows the method of ventilating large gambrel-roofed barns where a clear hay space is desired.

Fig. 7 shows the most common arrangement of flues in the King ventilation system. In all the variations it will be seen that the essential points remain the same. The fresh air comes in near the ceiling and the used air goes out through the outlet flue opening near the floor.

Inlets — Inlets should be placed on all sides of the barn, and should be small enough and numerous enough to admit a great deal of air at

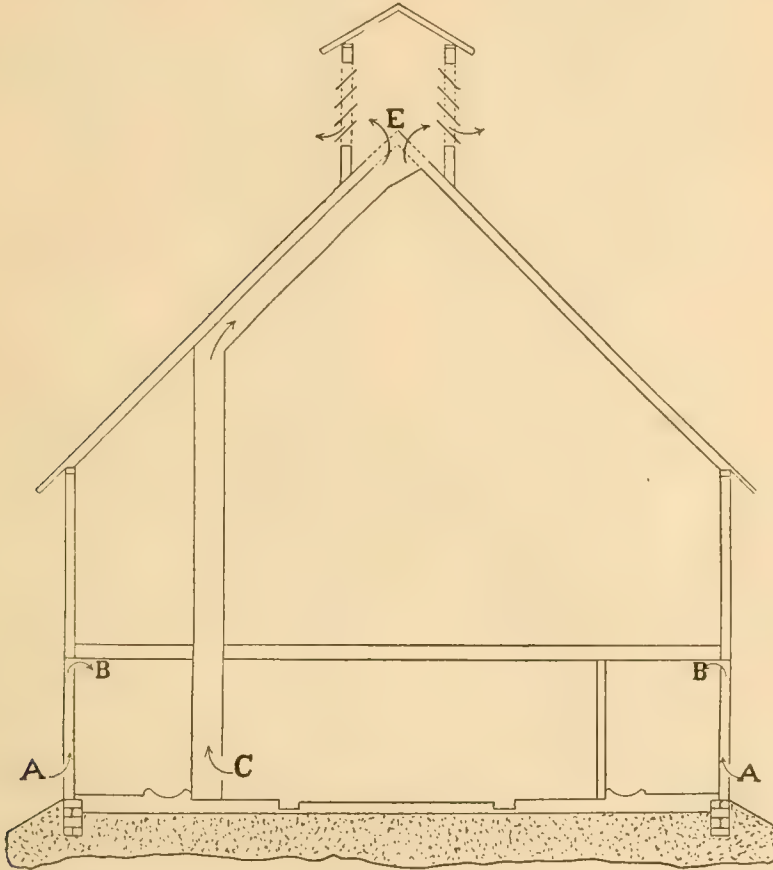

Fig. 7.—Ventilating a stable with a single outlet flue. The fresh-air intakes AB, are constructed about 10 or 12 feet apart between the siding and sheathing, or if of stone or brick, as shown in Figs. 10, 11 or 12. The ventilator flue, CE, takes up the place of only one cow, and fewer angles are necessary than where built up the side wall and around the plate and purline plate. A boxed hay chute with doors every five feet and an extension to the cupola may be used with very satisfactory results.

Courtesy of the Wisconsin Experiment Station

the same time. A mere hole in the wall will not do for an inlet — it must be arranged as a flue, so as not to create a draught across the room. Moreover, the opening A in the above illustration must never be less than three feet below the ceiling for then the warm air rushes out and the inlet is worse than useless. There should be from eight to ten inlets in a dairy barn.

Any of these inlets illustrated in Figs. 8-9-10-11 will work. It is a choice between them to meet conditions. Note that all have some form of a damper, as shown in D in Fig. 11. This is for the control of ventilation, and is an essential part of the system. Dampers are also placed in the outlet flues for the same purpose.

Outlets—There should be one outlet with a cross sectional area of

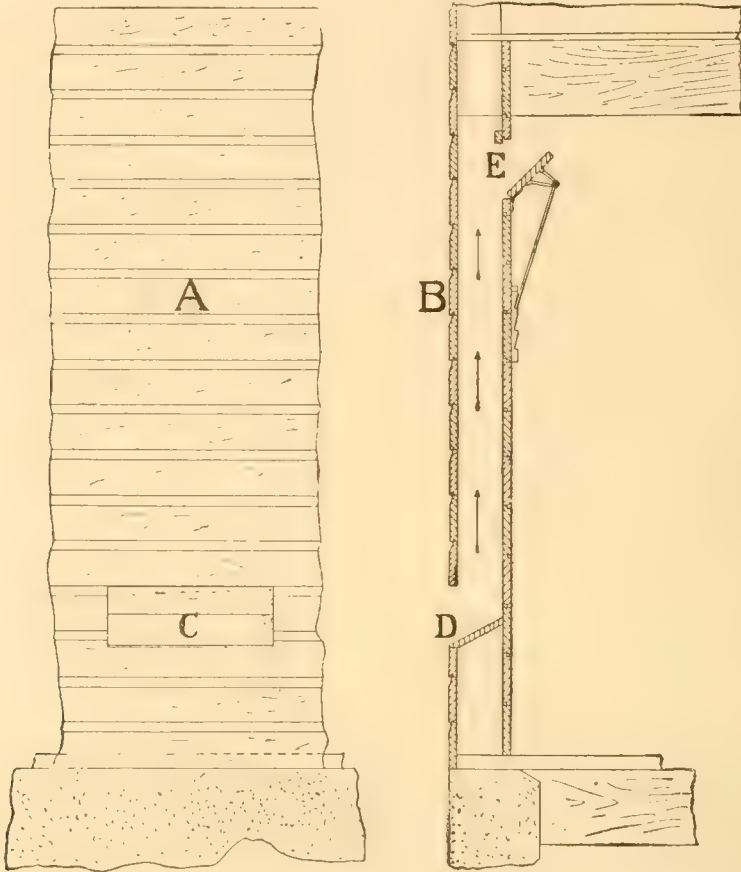

Fig. 8.—A wall section of a stable constructed of wood. The exterior A, shows the opening at C. The cross section B, shows the method of constructing the fresh-air intake. The outside opening is shown at D and the inside at E. A simple but effective valve to regulate the supply of fresh air is also shown at E.

Courtesy of the Wisconsin Experiment Station

four square feet for every twenty cows. These outlet flues must not be less than twenty feet high if they are to draw well. They should be air-tight and as straight as possible. For this reason those shown in Figs. 4 and 5 are the best to use.

As long as the air in the flue is comparatively warm, it continues to rise. But when it becomes cool, the flow ceases. When flues are run up inside the outer wall of a barn the air in them is bound to become

more or less chilled in winter, and the ventilation is impaired when it is most needed. Thus outlet flues should always be placed up through the mow, where it is warmest.

For temperate climates, and up to 42 degrees north latitude flues can be made of galvanized iron. This is cheap, air-tight, and easily

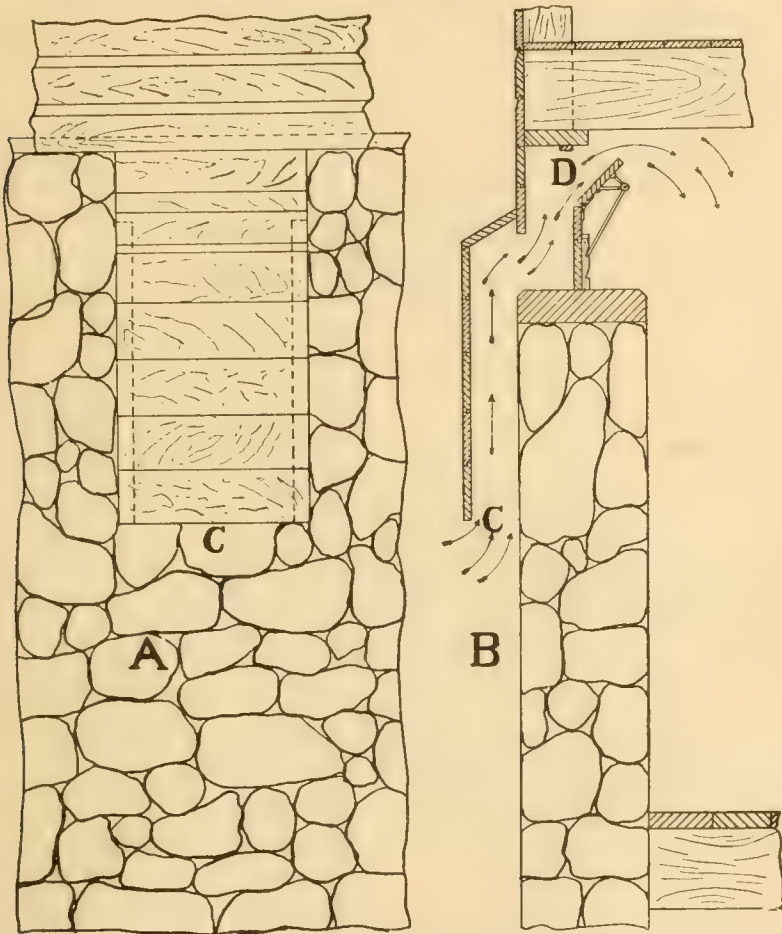

Fig. 9.—Method of constructing a fresh-air intake in an old barn, using an old window or an opening made for the purpose. Front elevation A and cross section B. Outside opening for the fresh air C, is made by using matched lumber, tarred paper and studding. In this way we have the opening CD, which furnishes air for the stable, allowing it to enter near the ceiling at D.

Courtesy of the Wisconsin Experiment Station

installed. In colder climates trouble will be had with the moisture collecting on the walls of the flue, but a casing of boards will prevent this. In very cold climates, however, where there is much zero weather, the galvanized flues will not work at all. The iron radiates off all the heat and the air ceases to rise. Here the wooden flue must be resorted to. It should be made of tongued flooring and lined with siding paper

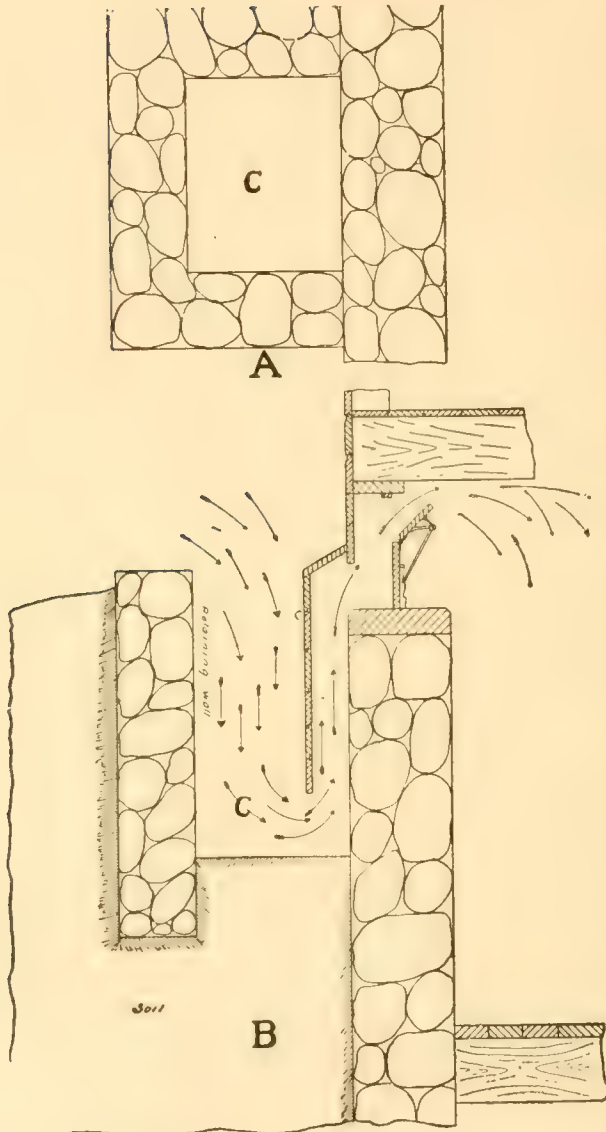

Fig. 10.—Method of constructing a fresh-air intake where the soil comes to or near the top of the wall, as found in many bank barns. Here an excavation is necessary. A cross section of the vertical opening or excavation C, is shown at A. The retaining wall prevents the soil from caving in. The area way is shown at C in cross section B.

Courtesy of the Wisconsin Experiment Station

of some sort to make it air-tight. Fig. 12 shows the detail of constructing a wooden outlet flue.

These figures, taken from King's "Physics of Agriculture," indicate the amount of air which the various animals require in respiration:

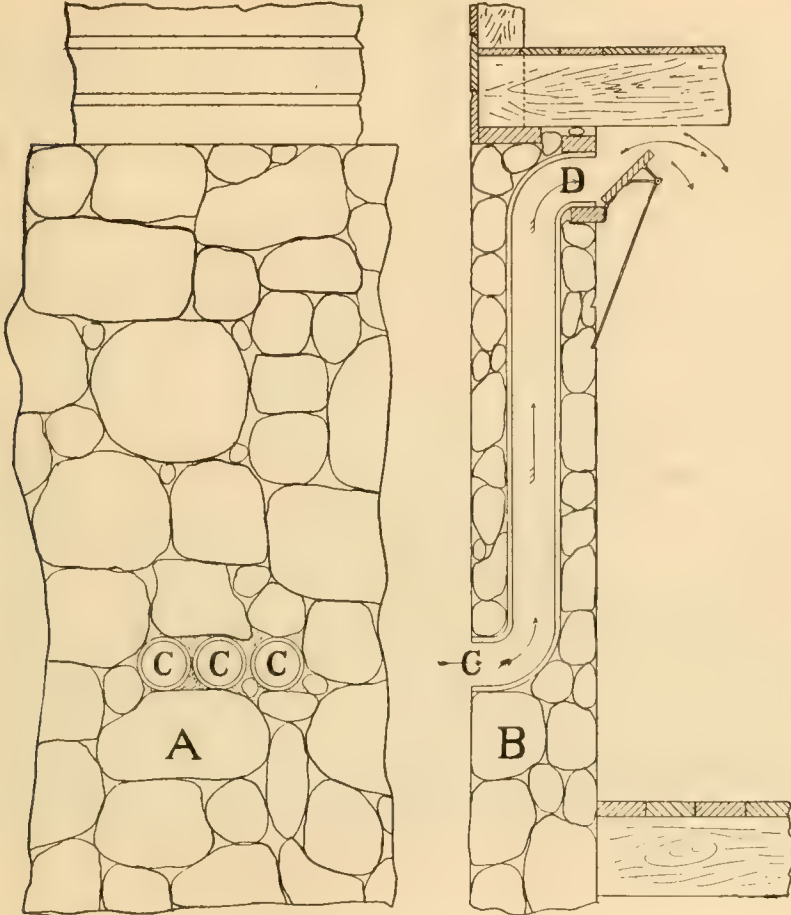

Fig. 11.—Method of installing a fresh-air intake in a stone wall during construction. Front elevation A shows openings CCC. Cross section B shows the air intake CD. This intake is constructed of vitrified sewer pipe.

Courtesy of the Wisconsin Experiment Station

For horses	71.	cubic feet per minute per head
cows	59.	" " " " " "
swine	23.2	" " " " " "
sheep	15.3	" " " " " "
hens524	" " " " " "

Assuming that the air travels through a flue from a stable at the rate of 200 to 300 feet per minute, we may easily determine the

number of cows which can be supplied with sufficient ventilation by a flue 16 x 22 inches inside measurement.

$$\frac{16 \text{ inches} \times 22 \text{ inches}}{144 \text{ square inches}} = 2.44 \text{ square feet.}$$

$$\frac{2.44 \text{ square feet} \times 295 \text{ per min.}}{59 \text{ cubic feet per head per min.}} = 12 \text{ cows.}$$

The total carrying capacity of the intake flues should slightly exceed the total carrying capacity of the ventilator flues. Such provision will insure plenty of fresh air.

From this simple formula the number of flues of any given size to be installed in a barn can be readily determined.

There are two things which will put the best arranged King system out of order. The first is the cooling of the outlet flues, which has been discussed, and the second is the admittance of draughts. It is absolutely necessary that the windows and doors fit tightly; that there are no cracks

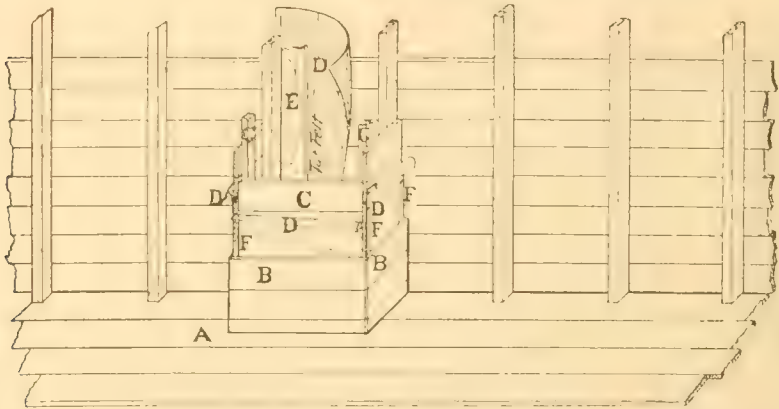

Fig. 12.—Details of construction of a foul-air flue. The hay floor, A, is above the stable. The exterior sheeting, B, of the flue is nailed to the furring strips F. These strips are nailed on after the paper D has been tacked to the interior sheeting C. The studding G, forms the two corners of the flue. The other two corners are formed by the studding of the barn wall. The method of covering the paper placed on the inside of the barn wall to form one side of the flue is shown at E.

Courtesy of the Wisconsin Experiment Station

in the walls or ceilings; and that the flues themselves are air-tight. The neglect of any of these essential points will throw the system out of order.

Lighting—Another natural condition which we can give the dairy cow, and which adds to her productivity, is light. Sunlight is nature's disinfectant. There is no germ known which can live for ten minutes in direct sunlight. Its admittance into a stable is better than a coat of whitewash every week. Moreover, a well-lighted stable is not so likely to be dirty—the dirt is too easily seen.

There should be from three to four square feet of window for each cow. A 3 x 3-foot window behind every other cow in a rectangular barn

is usually sufficient, but if the stable can be lighted from only one side, the windows should be six feet high and practically continuous.

Stalls— In choosing the type of stall for the dairy barn, one should bear in mind that the stall which keeps the cow in her most natural position is the one to use. Cows which are held in a cramped position by the old-fashioned fixed stanchion are never so productive as those which have more liberty. There is a tendency among up-to-date dairy-men to dispense with the stanchion altogether, and substitute the stall and chain. The use of a stall is advisable even when stanchions are used. Any device for holding cows in their places should do the following things:

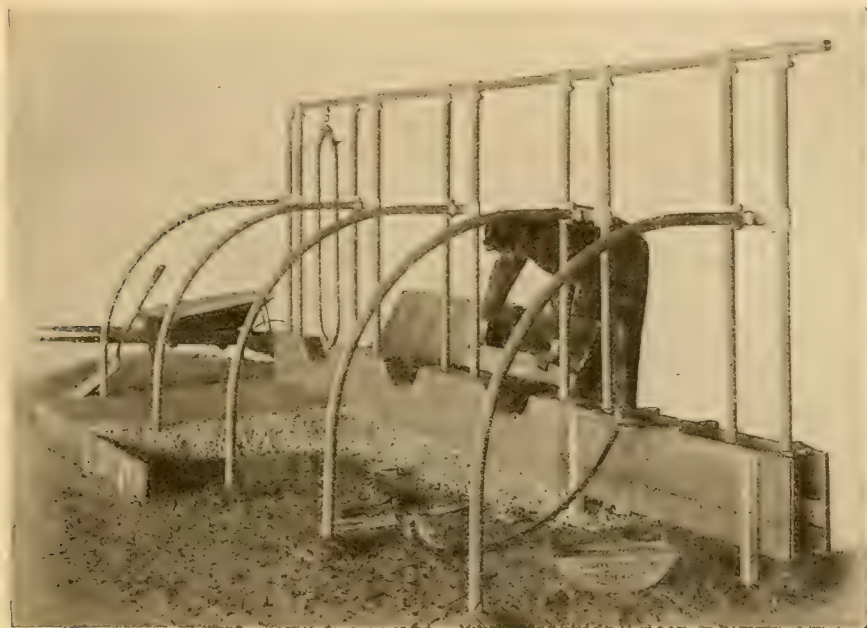

Fig. 13.—Installing Steel Swinging Stanchions.

1. It should keep the cow clean. Dirty cows mean dirty and insani-tary milk. To do this it should not be too wide.
2. It should hold the cow securely.
3. It should make the cow comfortable.
4. It should be convenient for milking, cleaning and feeding.
5. It should be inexpensive and durable.

It will be hard to find a stall that meets all these requirements at the same time, and so we must do the best we can in making the selection. Probably the stall which meets most of the requirements is the steel stall which consists of bent piping, set in the concrete, as shown in Fig. 13.

The figure shows the steps in the installation of these stanchions, and the necessary tools. According to Fig. 13 it appears as though the stanchions were put in one by one.

The plate on the next page gives a cross section view of a dairy barn, equipped with steel stalls and a concrete floor. It shows the relative elevations of the different parts of the stable floors. The ground plan is also given to make the plan complete.

However, the number of stalls to be started at one time is limited only by the amount of help available. It should be remembered that when concrete is once well set, it will not knit very well with fresh concrete, and so the steps should follow one another as rapidly as possible. It is usually advisable to employ a mason to assist the farmer in this work.

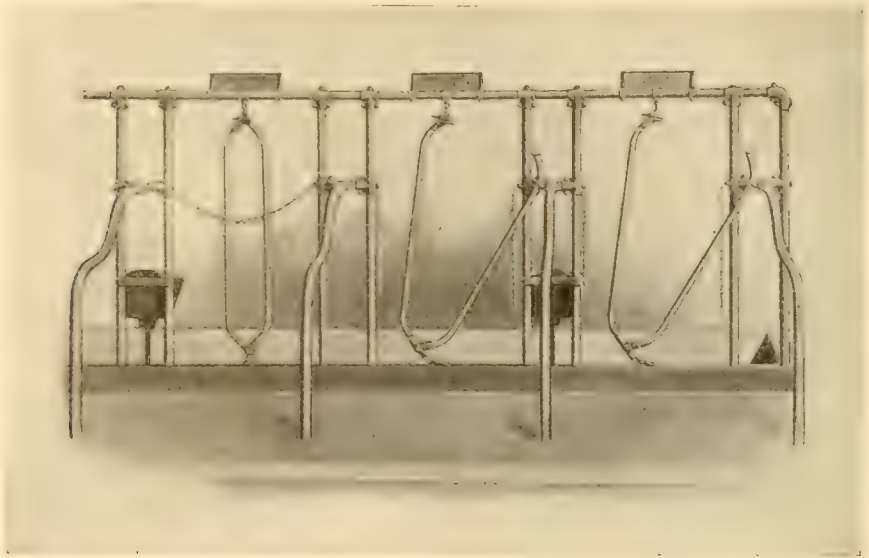
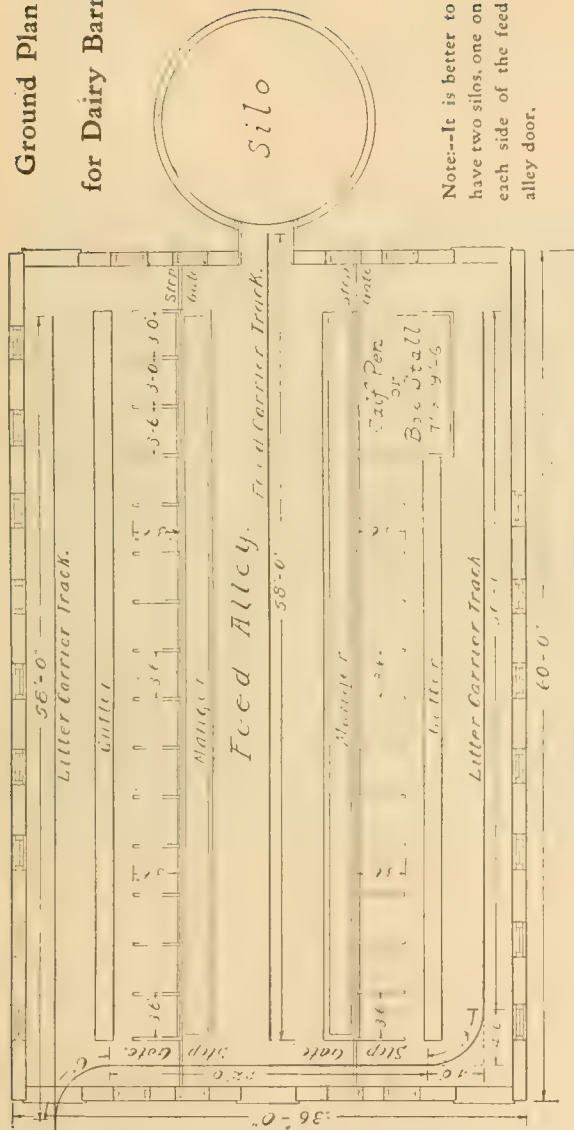

Fig. 14.—Two-Post Stalls with Neck Chains, Name Plates, and Drinking Cups.

The stall shown in Fig. 13 is probably the best one for general purposes. It meets most of the requirements of a good stall, including reasonableness in cost. Some additional devices which increase the cost and may or may not improve the stalls are as follows:

1. Wood-faced stanchion bars which keep the cow's neck from contact with cold rusty iron, can be substituted for the steel tubing.
2. A bar to make the cows put their heads through the stanchions instead of between the stanchion and the post, when they are let into their places, is a convenient attachment.
3. Name plates above the cows' heads, shown in Fig. 14, assist in the keeping of records.

Ground Plan
for Dairy Barn



Note--It is better to have two silos, one on each side of the feed alley door.

Enlarged Cross Section View

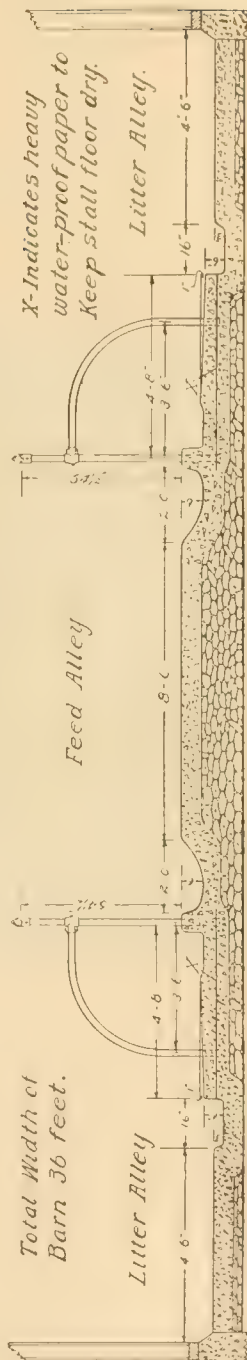

Total Width of Barn 36 feet.

X-Indicates heavy water-proof paper to keep stall floor dry.

4. An improved stanchion lock, which has a rod running through a hollow tube is on the market. The rod has the catch on it and never completely leaves the tube, but keeps the movable stanchion bar from dropping to the floor. When closing these stanchions there is never any trouble with missing the lock, for one end of the rod is always in the hollow tube. There is no form of stanchion that can be as easily and rapidly closed as those having this kind of latch.

5. Neck chains shown in Fig. 14 may be put in. These may be used to keep the cows from lying down when it is desired that they remain standing.

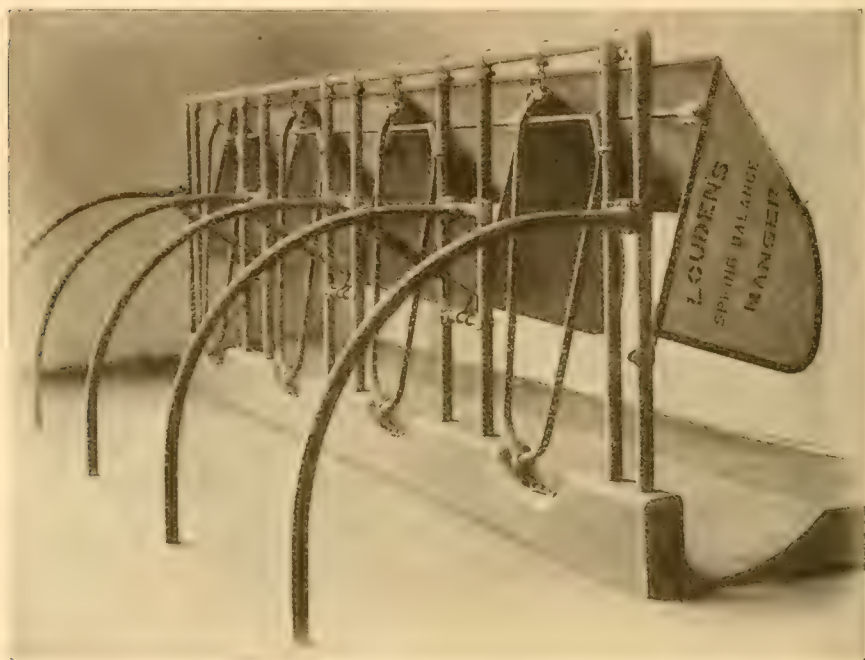

Fig. 15.—Steel Mangers Which Can Be Easily Raised for Cleaning.

6. The individual steel manger can be had in various designs. One form is shown in Fig. 15. The springs facilitate the raising of these partitions for cleaning. Where a man wishes to feed his cows individually and be sure what each is getting, the individual manger is indispensable. Before putting them in for a general farm barn, however, the fact that they increase the labor of feeding should be considered.

7. The drinking cup shown in Fig. 14 will be described under the watering system.

8. The adjustment attachment enables the farmer to adjust the distance between the stanchion bars to suit the size of the cow's neck.

9. Second adjustment, not shown in any stall, by which the whole

stanchion can be moved forward or backward to suit cows of various lengths, thus avoiding cramping long cows and keeping short cows clean, is manufactured by the same company that makes the improved stanchion latch described in 4.

All of these additions greatly improve the stall and stanchion but also add to the cost. It may be advisable for none but those who keep pure bred stock to increase the cost of their stable by the use of some of them, with others the saving in time during the years that follow will more than repay the additional expense.

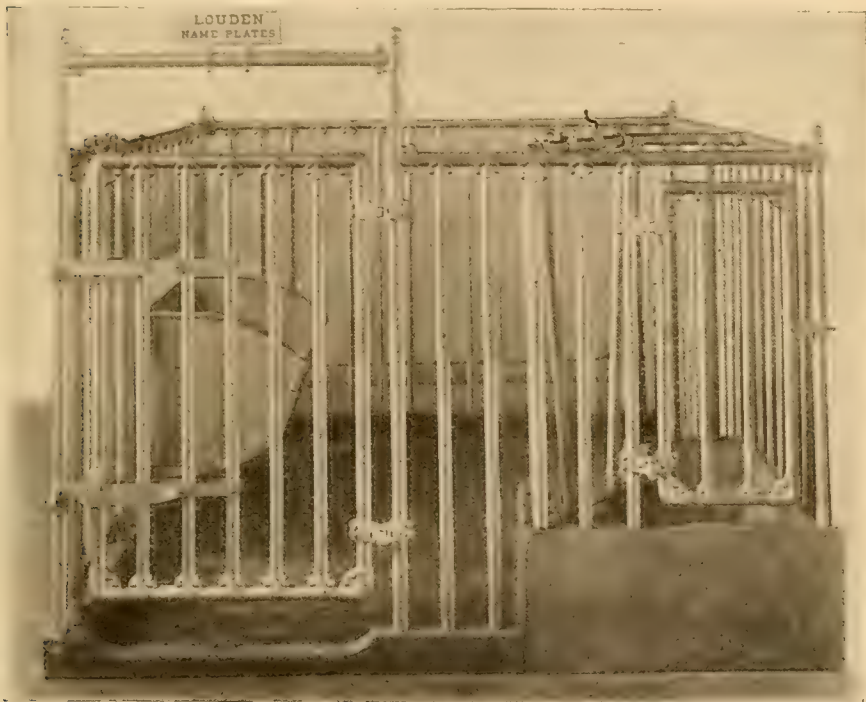

Fig. 16.—Steel Bull Pen. (Note stanchion in forward corner on right and the door leading to it. Note also the plank bottomed tilting manger.)

Another type of stall is the stall with a chain behind the cows to keep them from standing in the gutter with their hind feet, and some bars in front of them to keep them from depositing their droppings in front of the gutter. The cows are loose in these stalls and so a fairly tight partition is needed between the stalls. These stalls and the old-fashioned neck chain are perhaps the most comfortable fastening devices for cows.

Bull Pen—Every stable needs a bull pen. This may be like the one in Fig. 16 which has a tilting plank-bottomed trough, two doors and a stanchion in which the bull can be fastened while one is working in the pen. The farmer may build a pen out of lumber at a lower cost,

but the objection to a wooden structure in the stable is that it gets broken and also obstructs light.

A calving pen of lighter steel tubing should also be provided. It need not, however, have the stanchion and the extra door, and the tilting trough need not have a plank bottom. Sheet iron will do.

A calf pen of still lighter material with ordinary fixed stanchions along one side should also be in every modern dairy barn. These stanchions in the calf pen need not be swinging and can be made of steel tubing or of wood. They should be attached to a bar so that all can be opened and closed at one operation.

The steel bull pen, steel calving pen for cows, and the steel calf pen are not absolutely essential to a good dairy barn, but if these are not put in, the farmer should substitute a wooden bull pen made out of oak or elm, a box stall for calving, and a wooden calf pen. The bull does better loose than tied up; cows should never be permitted to calve in stanchions; calves do much better if they are loose in a pen and should be put in stanchions only for feeding. Some farmers prefer a separate building for the bull and probably this is the best plan, but it usually involves expense and inconvenience in feeding. A vicious bull may be kept tied and yet given exercise by running a wire cable with a ring on it through his pen about six feet from the floor. This ring is connected to the one in his nose with a chain. This affords him enough and yet not too much freedom.

The Water Supply — The water supply for dairy cattle should come from a natural spring or a deep well. Water should never be used that comes from a shallow well which may have become contaminated with sewage or manure. Contaminated water will spread disease as quickly among cattle as it does among human beings.

At the present time it will be very hard to find a dairy farmer who drives his cattle to a creek or river to drink on cold winter days, but there are still some who water them at a tank in the barnyard. The barnyard tank is very good in the summer time, if it is kept clean and filled with fresh water, but in the winter the cows will not drink as much of the icy water as they should. Good dairy men realize that cows must drink a large amount of water to produce a large quantity of milk, and so some place tanks in the stables. The chief disadvantage of this system of watering is that turning all of the cows loose at a time results in crowding, slipping and falling on the concrete floor. Of course, this could be avoided by watering in twos and threes, but this would require too much time. Another disadvantage is that the stable would be covered with manure when the cows are through drinking. These disadvantages are so great that the dairy farmers prefer to use either the concrete manger as a trough for watering, or the individual drinking cup. Both have their advantages and disadvantages.

Watering in the manger is accomplished by letting the water into one end of the manger from a faucet. It has the advantage of a lower initial cost, of always providing fresh water, and, incidentally, of cleansing the manger at each watering. There is no danger of flooding, for the farmer must be at the faucet. Some disadvantages are: there is always some waste water which must be let into the drain after each watering; spreading of diseases through water is as easy as in a tank; it takes time and attention to operate; and the cow cannot drink when she is thirsty but must wait for watering time.

The advantages of the drinking cup plan are: The cow can drink whenever she is thirsty; its operation requires no attention from the farmer; and there is less chance of spreading disease among the herd through the drinking water. Its disadvantages are: the initial cost is higher; the cups will need an occasional cleaning; the system may get out of order and empty the reservoir. If the farmer has a good drain to carry off the water and a gasoline engine to pump water the next morning this will not vex him very much; moreover, with good valves in the cup, this would very seldom happen. A float system combined with this valve system would give double protection against accidental flooding.

Progressive dairy men are divided in opinion as to which of these systems is the best and most profitable one in the end.

Both the manger and the drinking cup system require a reservoir in the form of a concrete cistern at some elevated point on the premises, a tank located above the ceiling of the stable, or a steel pressure tank. The only time that the tank is preferable to a cistern is when the land about the premises is level. If expense is not an important factor the steel pressure tank is far more desirable than a stable tank because it can be used for all the buildings about the farmstead; but the concrete cistern, if it can be used, will accomplish the same thing at a much lower cost. The tank in the stable should be avoided, if possible, for the water absorbs gases, and the tank must be filled daily or else the water becomes too warm. Cattle dislike water that is stale or too warm quite as much as icy water.

One or two hundred dollars invested in a good watering system will do a great deal to make farm life more attractive as well as to increase the profits from the dairy herd.

Manure Pits—The proper location of the manure pit is at the end of the carrier tracks. These pits should be built of concrete and should always be roofed. To pile up manure in the barnyard where one-half of the nitrogen will leach away and the other half will go off as ammonia is a very foolish extravagance. To bore holes in a wooden floor for the urine to run through is even worse waste. Every bit of manure, both liquid and solid, should be carried and drained into a concrete manure

pit, where it will be protected from the weather and conserved for future use of the land. Directions for building the pit will be found in Book V, Chapter VI.

THE ROUND DAIRY BARN

A glance at the plan of the round dairy barn will reveal its two

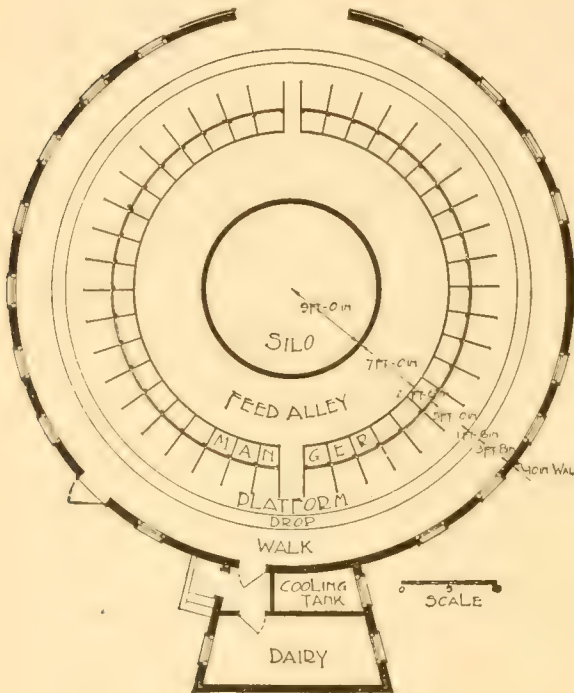

Fig. 17.—Plan for Round Dairy Barn.

Courtesy of the Illinois Experiment Station.

important features, first, that it is nothing more than a long rectangular barn bent into a circle, as far as the plan is concerned, and second, that the silo stands at the center of the building.

This construction means a big saving in time and labor, for the feeding, beginning at the hay chute and the silage chute, not three feet away from the stalls, goes around the circle of stalls and ends with the silage cart at the chute again ready for the next feeding. Similarly, there is a saving both at milking time and in

cleaning. Then, with the self-supporting roof, as shown in Fig. 18, there is a haymow unobstructed by braces and supports, with the hay carrier running in a circle between the wall and the silo. In no case will the hay have to be moved more than a few feet. All these minutes saved at each task mount up in the course of a year.

The circular construction of a building is the strongest known, because it takes advantage of the lineal rather than the cross section breaking strength of lumber. A properly hooped barrel is practically indestructible. In the round dairy barn each row of boards forms a hoop which holds the barn together. It cannot be blown down and it cannot sag.

The silo, being in the center, need not be so strongly built and can be made much larger than an external silo. One of the inexpensive Gurler forms serves very well in a round barn where it is protected from the wind. It can often be made large enough to take the place

of two concrete silos. It can be 60 feet in height as silage cutters are now equipped with blowers which will elevate the silage 60 feet or more. A center silo, moreover, is twice as convenient as any placed outside could be.

The following balance sheet is an average sheet drawn up at the University of Illinois. It shows pretty conclusively the advantage that the round dairy barn possesses over a similar rectangular one in costs.

A COMPARISON OF THE COST OF MATERIAL IN ROUND AND RECTANGULAR BARN, INCLUDING FOUNDATION AND SILOS

	Round barn, 60 feet in diameter	Rectangular barn, 36 x 78½ ft.	
		Plank frame	Mortise frame
Lumber in barn.....	\$799.76	\$1,023.27	\$1,233.41
Material in foundation.....	86.89	105.90	105.90
Material in silo.....	159.01	295.26	295.26
Total cost of material in barn.....	\$1,045.66	\$1,424.43	\$1,634.57
Actual money saved.....	\$378.77	\$588.91
Proportional cost.....	100 per cent	136 per cent	156 per cent



Fig. 18.—Barn 40 feet in diameter.

Courtesy of the Illinois Experiment Station

	Round barn, 90 feet in diameter	Rectangular barn, 36 x 176¼ ft.	
		Plank frame	Mortise frame
Lumber in barn.....	\$1,628.48	\$2,007.67	\$2,497.56
Material in foundation.....	130.35	196.80	196.80
Material in silo.....	265.00	513.52	513.52
Total cost of material in barn.....	\$2,023.83	\$2,717.99	\$3,207.88
Actual money saved.....	\$694.16	\$1,184.05
Proportional cost.....	100 per cent	134 per cent	158 per cent

It will be noted that the saving in cost of the round dairy barn ranges from 30 to 50 per cent, depending upon the size of the barn.

The construction of the dairy barn is somewhat more complicated than that of the rectangular barn, and the following plates show rather clearly the actual processes in erecting the barn. Any country contractor should be able to build the round barn, however, as there is nothing difficult about it.

Note the continuous sill. This is made of $\frac{1}{2}$ x6-inch strips nailed together and bent to the circumference of the barn. Ten strips are used, making a continuous sill five inches thick on top of the brick foundation.



Fig. 19.—First-story Wall and Foundation for Silo, Feed Alley and Manger; Sill in place, ready for joists and studs.

Courtesy of the Illinois Experiment Station

Note also that the silo is put up first, and serves as a support for the rafters until the whole structure is up. The method of bracing the rafters at the joints is clearly shown.

Floors—The floors should be made of concrete. The courses must of course, be laid in circles, which is rather more difficult than laying an ordinary cement floor. The following device, consisting of a rod driven into the ground at the center of the circle with a 2 x 4 arm bolted loosely to it and a movable marker, will aid in laying off the floor. The arm should be long enough to reach the side of the barn.

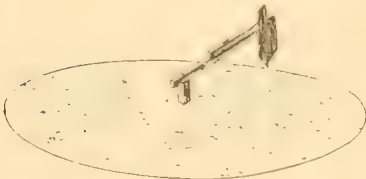

Fig. 22.—Laying Out the Circle

Where wooden floors are laid it will be found most convenient to follow the method indicated in Fig. 22. The joists are laid from the silo wall to the outer sill, and the flooring is simply laid square about the silo.

Ventilation—The King system should always be used in a round barn. The flues run up the silo wall, where they always have a sufficient height to draw well, and are kept warm by the hay and silage. This was illustrated in Fig. 5 under

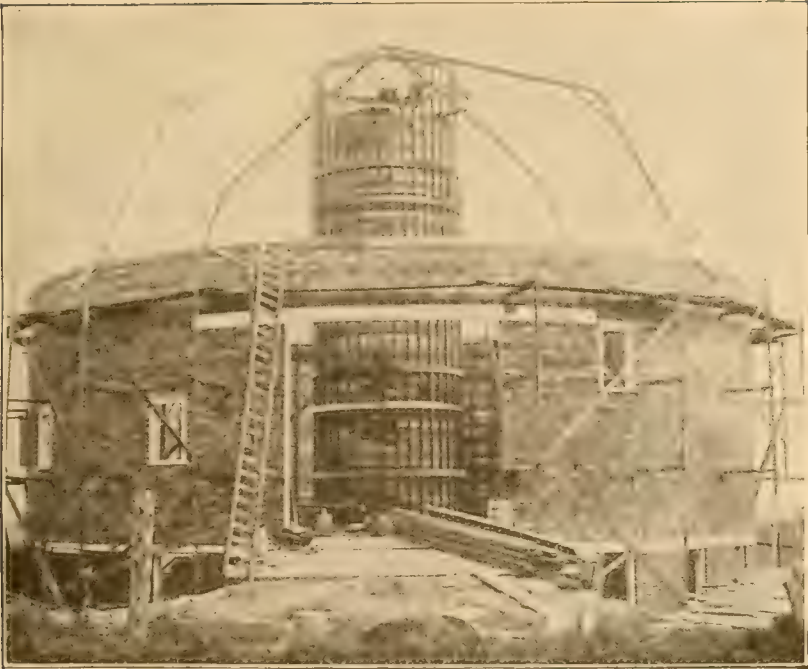

Fig. 20.—Showing height and construction of silo, siding completed and four main rafters in place.

Courtesy of the Illinois Experiment Station



Fig. 21.—The Barn Completed.

Courtesy of the Illinois Experiment Station

“Ventilation by King System.” If a ventilator be put in the roof above the silo there will be no annoyance from silage odor.

Lighting — In the round barn light can be obtained only from one side, but its circular construction makes it well lighted in spite of the silo in the center. The rule of one 3 x 3-foot window behind every other cow should be strictly adhered to.

Stalls — It is well to mark off the stall divisions while laying the floor, as the sides of the stalls are segments of the common radius, and it will be difficult to mark them off properly after the silo has been

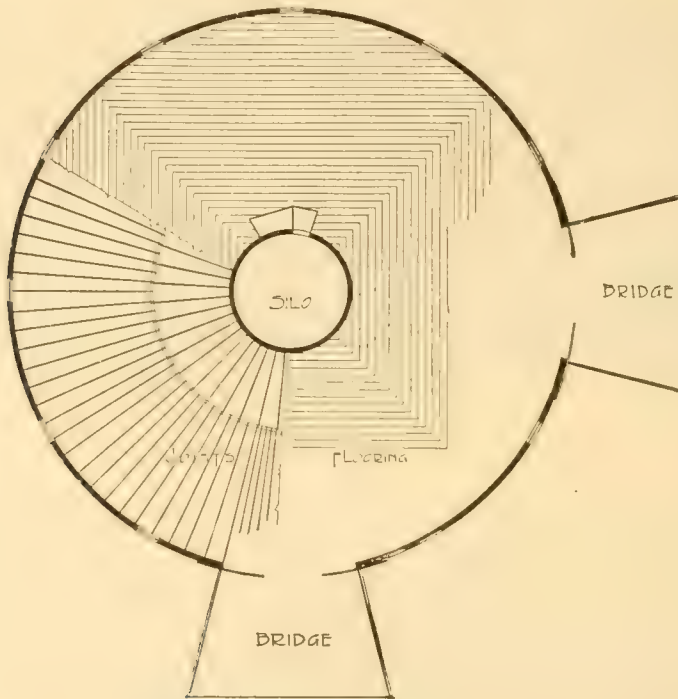

Fig. 23.—Showing arrangement of joists and how the floor is laid.

Courtesy of the Illinois Experiment Station

put up. Each stall is a little narrower at the head than at the milking alley, but this does not matter, as it fits the cow. The circle which marks the gutter should be laid off in 3-foot 6-inch intervals. Allowing 5 feet for the length of the stalls, this will leave about 3 feet for the width of the stall at the feed alley, depending, of course, on the width of the barn. The stalls can be set in while laying the floor, if they are the patent type, although it is best to set them in after the building has been completed to save trouble.

The round dairy barn has the advantages of being more convenient, stronger, and less expensive than the rectangular barn. But additions

to the barn cannot be added when once constructed, and the farmer should give this due consideration when building. As a rule, however, the round dairy barn is to be recommended for well established herds representing a stable investment, where the effort is to secure quality rather than quantity. It is only fair to mention, however, some very definite objections to the round barn which should not be overlooked by those considering the construction of a dairy barn. The round barn cannot be so thoroughly lighted as a narrow rectangular building with windows on both sides, because the light has so much farther to travel. This is especially true of barns of large diameter. Many types of silos do not need the protection of the barn and can be more easily filled when placed outside. Thus, to some the placing of a silo inside represents a waste of room.



Fig. 1.—Two Stave Silos at the Dairy Farm, Iowa State College, showing a desirable location.

Courtesy of the Iowa Experiment Station

CHAPTER IV

SILOS

- I. INTRODUCTION—LOCATION—SIZE. II. HOOP SILO—ROOFS. III. STAVE SILO—DIFFICULTIES OF BUILDING—METHODS OF ERECTION—DOORS—REINFORCING—THE ROOF—GUY WIRES. IV. VITRIFIED BLOCK SILOS—SELECTION OF BLOCKS—DEVICES OF CONSTRUCTION—FOUNDATIONS—DOORS—REINFORCEMENT—THE ROOF—WASHING. V. THE CEMENT BLOCK SILO. VI. SOLID CEMENT SILO—THE MIXTURE—FOUNDATION—REINFORCING THE ROOF. VII. THE PIT SILO—LOCATION—CONSTRUCTION—REMOVING SILAGE. VIII. TABLES FOR SILO CONSTRUCTION.

INTRODUCTION

The fundamental principle in the preservation of silage is the retention of the moisture within the silo and the exclusion of the air without. For this reason the silo must be impervious to air and water. It must have strength, for the pressure which the silage exerts upon the walls of the silo to burst it, is eleven pounds to the square foot for each foot of depth. Its inner walls must be smooth, for silage always settles a few feet after filling, and if the walls are rough, air spaces are left in settling, about which the silage spoils.

It is desirable that the silo be durable and inexpensive to keep up. It is almost essential that the walls be thick enough to prevent freezing and solid enough to prevent blowing over. It adds materially to the value of a silo to be made fire-proof.

Yet these are only desirable features — the essential ones are smoothness, strength, and imperviousness of the silo's walls.

Location — Silos, with the exception of the round barn silo, should always be located outside of the barn to economize space and to avoid the silage odors. It is immaterial whether it be placed at the end or

the side of the barn, provided that it has direct connection with the feed alley. It should have a solid and well-drained base to rest upon wherever it is located. Figure 1 shows a couple of well-located silos.

Figure 2 shows what is meant by connection with the feed alley.

Size—The quality of the silage improves as the depth increases, owing to increased pressure and to exclusion of air. The depth of a good silo should be at least 30 feet. The capacity of a silo varies as the square of the diameter, while the wall surface varies directly as the diameter. This means that as far as capacity is concerned the silo should be of as large a diameter as possible. There are limiting factors, however. When silage is exposed to the air for more than a day it spoils. This means that at least one and a half inches must be taken off the top of the silage in feeding each day to keep it fresh. Moreover, a silo, if of light construction, should not be more than twice as high

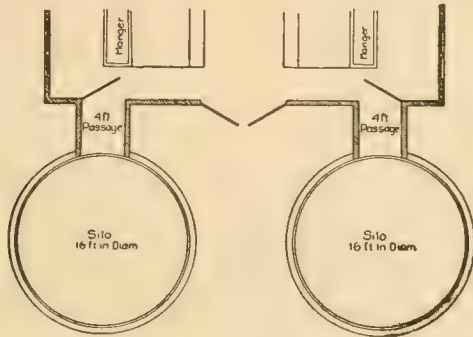

Fig. 2.—Plan of the Silos of Fig. 1, showing a convenient arrangement for feeding.

Courtesy of the Iowa Experiment Station

as it is wide to prevent its blowing over when empty. On the whole a silo 16 feet in diameter and 30 feet high or more seems to be the best size to build.

The first silos built in this country were square. It was found almost impossible to make the walls of these silos strong enough to withstand the pressure, and their sides always bulged. It was also difficult to fill the corners, and a great amount of silage was lost annually through spoiling and freezing. It was only when the round silo was perfected that silage came into general use.

Kinds—There are four kinds of round silos in practical use today: the all-wood silo, of which the Gurler and hoop silos are types, the stave silo, the vitrified clay and cement block silo, and the cement silo.

THE ALL-WOOD SILO—GURLER TYPE

Foundation—The foundation of every silo should be broad enough to prevent settling, and deep enough to avoid frost danger. This means that the foundation should extend about three feet into the ground. All

foundations should be of concrete. They need not be more than 6 to 8 inches thick, with footings 16 to 20 inches wide, as they support only the walls and roofs of the silos. Figs. 3 and 4 show the method of putting in a foundation.

In putting down the forms, stakes are simply driven into the ground as shown, and thin boards bent around them. The cement can be pointed off and smoothed after the forms are removed. Note that the forms are not carried all the way down to the bottom of the excavation. This gives the cement room to spread at the base, making a firmer foundation. It is a very

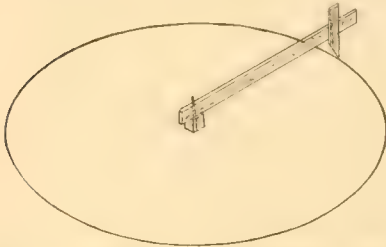
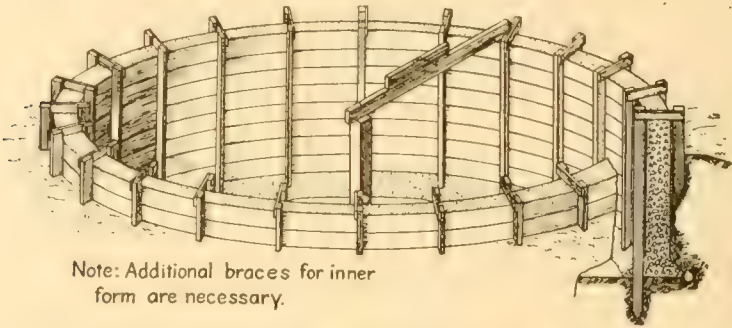

Fig. 3.—Laying Out Circle for Excavation a simple method of constructing a foundation and more practical than some that are more complicated.



Note: Additional braces for inner form are necessary.

Fig. 4.—Forms for Making Concrete Foundation.

Courtesy of the Iowa Experiment Station

The Floor—It is desirable that every silo should have a cement floor to keep out ground water and prevent the silage from spoiling. This can be laid the same as a cement sidewalk and need only be two inches thick, since the ground and not the floor supports the weight of the silage. With a cement floor there is less danger of water getting into the foundation and freezing—an incident that has ruined many a good silo.

Walls—The Gurler silo is primarily a silo to be used in round dairy barns. It consists of upright studding bound together with hoops made of three-ply $\frac{1}{2}$ x 6-inch lumber. When used outside, vertical siding should be nailed outside of the hoops and battened down. The inside is lathed horizontally with special heavy lath and then plastered with cement plaster.

The Gurler silo is not strong, and needs the protection of a building. When used outside it is liable to warp and draw out the nails in the siding. This fault can in part be remedied by the addition of diagonal hoops or

braces. It should not be used in outside construction, however, if there are any other types available.

THE HOOP SILO

The wooden hoop silo has come into use chiefly in the East. The essential features of the hoop silo can readily be seen in Fig. 5, which shows one under construction.

The wooden hoops are made by nailing together several thicknesses of beveled weather boarding, or better still, redwood, bent to the circumference

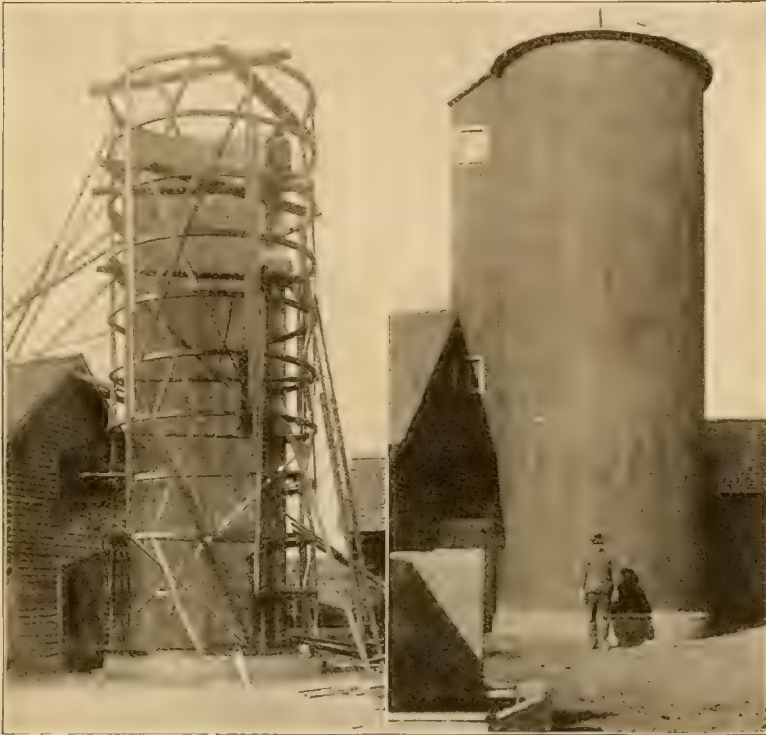

Fig. 5.—A Wooden Hoop Silo Under Construction.

Fig. 6.—The Wooden Hoop Silo Completed.

Courtesy of the Iowa Experiment Station

of the silo. Fig. 7 shows a cross section of a hoop made of beveled siding. The boards are bent around stakes set in a circumference the same as that of the hoop silo. The hoops are placed three feet apart and lined inside and out with a good grade of flooring.

Roofs—This type is an exterior type of silo, and in common with all exterior types, should have a roof. Roofs prevent freezing and decay in wooden silos. They make the silo a pleasanter place to feed from in wet weather, and prevent the covering of silage with snow.

The best way to make a roof is to brace in an upright post in the center with cross-pieces, and nail the rafters and cross-ties to the upright as shown in Fig. 8. A one-third or one-fourth pitch roof should always be used, as a flatter roof does not permit the silage to be heaped up for settling.

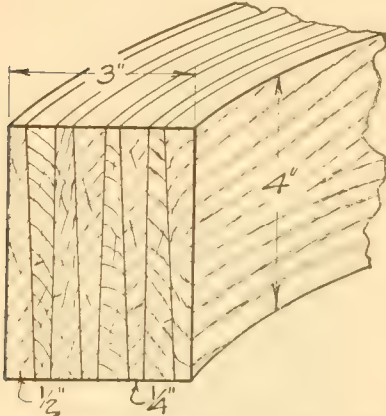

Fig. 7.—Detail of Wooden Hoop Silo.

In the best wooden roofs, sheeting is sawed into triangles and both ends nailed to the roof as shown in Fig. 9. Then some patent roofing is cut into triangles to fit the roof and laid on over the sheeting. Plain boards do not make a good silo roof. Silo roofs should always be provided with a dormer or a trap window. The trap is the best and the easiest to construct. There are two reasons for a window. First, there must be an opening for the blower of a silage cutter, and second, some light must be admitted when feeding. It is very disagreeable to have to feed silage by lantern light, and altogether unnecessary.



Fig. 8.—False Work and Cornice Block in Place to Receive Sheeting.

Courtesy of the Iowa Experiment Station

THE STAVE SILO

By far the majority of silos now in use belong to this type. It is exceedingly difficult to construct a home-made stave silo. In the first place it is difficult to obtain the proper lumber at local yards. Then the staves, not being beveled and grooved, slip past each other in summer, and the silo warps in spite of the hoops. The home-made silo, moreover, is difficult to set in place. With so many good patent silos

in the market, silos that are conveniently arranged and easily set up, it pays the farmer to buy one ready-made rather than try to make one himself. The initial cost of the ready-made silo is somewhat greater, but its maintenance cost is much less and its life is longer.

It is the quality of the lumber used that determines the success or failure of the stave silo. Redwood, cypress, and Oregon fir make the best material for silo staves, and should be demanded by the farmer. Badly cross-grained lumber, or that containing heart or windshake, sap, or bark, should be discarded even if at the expense of the buyer. A poor stave should never be put in a silo as it lowers the value of the whole silo. All staves should be creosoted at the bottom, as wood which rests upon concrete quickly decays unless preservative measures are taken.

In ordering staves, the circumference of the silo divided by the width of the stave desired gives the number of staves needed.

Figures 10 and 11 show two methods of erecting the stave silo.

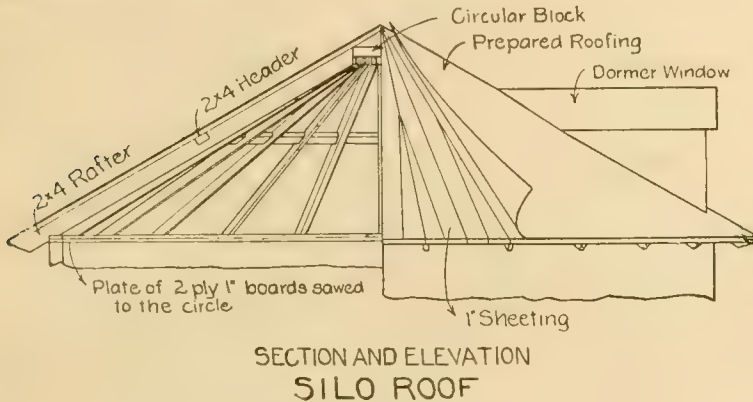

Fig. 9.—Silo Roof of Prepared Roofing.

Courtesy of the Iowa Experiment Station

The first method is the one most commonly used. Scaffolding is inexpensive, and enables one to paint the silo before it is taken down. In the second method the door frame is first guyed in place. The staves are then raised three at a time and held in place by barrel staves nailed on inside with shingle nails, and by the cross boards at the top. This saves time and staging expense, but requires some skill on the part of the man on top.

Doors—In the patent stave silos, the door frames are all ready to put in place, and the doors ready to hinge. Thus a great saving of time and energy is made in this item.

The doorways of the stave silos are continuous, with heavy cross-ties. This is clearly illustrated in Fig. 11.

In the home-made silo two 4x4 posts, running the entire height of the silo, and tied together with heavy iron rods form a good doorway. Figure 13 shows the proper type of door to use. It may be either hinged

to the door-frame or be loose. In the latter case it must be beveled to fit the frame from the inside.

A common method of fitting is to nail on a piece of galvanized iron, which extends two inches beyond the edge of the door on all sides. The door is held in place by the iron rim and the outward pressure of the silage, making it flush with the inner wall of the silo.

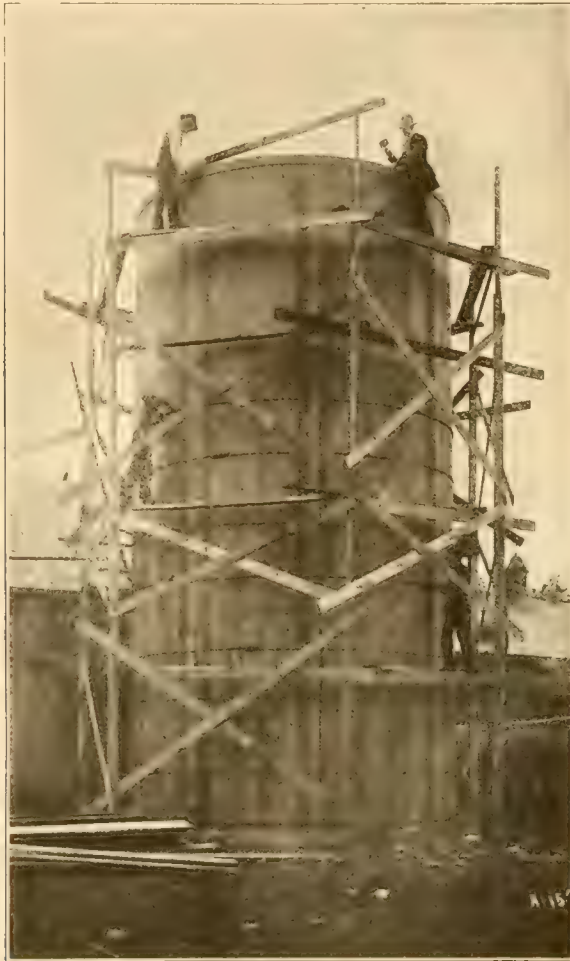

Fig. 10.—Erecting Stave Silo with Scaffolding.

Courtesy of the Iowa Experiment Station

All doors must form an air-tight joint. This is sometimes secured by nailing felt to the edges of the door. The simplest and easiest way to make a door air-tight is to fill the cracks with a pliable clay. The moisture of the silage inside will keep it from drying out, and it forms an effective joint.

Reinforcing — All stave silos, if they are to hold together at all, must

be bound with iron hoops. These hoops should be placed not further than 18 inches apart, and should always have provision for adjustment.



Fig. 11.—Erecting a Stave Silo without scaffolding. Door frame in place and raising staves.
Courtesy of the Iowa Experiment Station

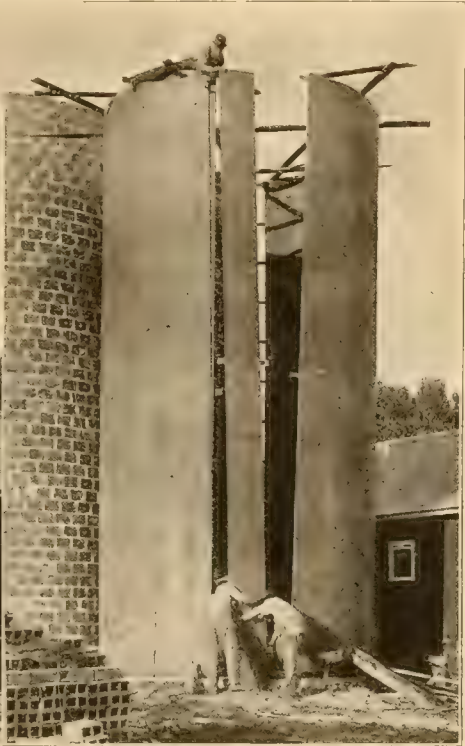

Fig. 12.—Erecting a Silo without scaffolding. Finished.

This is necessary so that the hoops can be tightened and loosened when desired. All silos should have at least two hoops on the inside, one at the top and another at the bottom of the silo, so that the staves cannot fall inward if they become loosened. Many patent silos have these; if they have not, the buyer should insist upon having them put in, as they may save the silo from going to pieces if the roof should become loose.

The Roof—The construction of the roof is identical with that discussed under the all-wood silo, and the reader is referred to that section for its construction.

Guy Wires—Figure 15 shows just exactly what happens to a stave silo that is not properly guyed. It is in constant danger of collapse in summer.

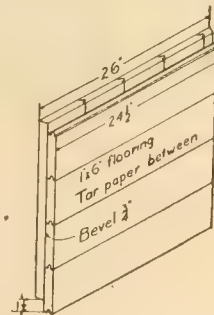

Fig. 13.—One Type of Continuous Door.

The wooden stave silo has the advantage of being constructed with the minimum expenditure of time and labor. It is easily repaired. It is also the only silo which can be moved from one place to another.

THE IOWA OR VITRIFIED CLAY BLOCK SILO

In these days of concrete construction every mason has the proper moulds for erecting a silo, whether of the block or solid concrete type. While it is unnecessary to discuss the details of construction, yet there are some things which the farmer should understand about silo building, that he may not be entirely at the mercy of his mason and dealers.

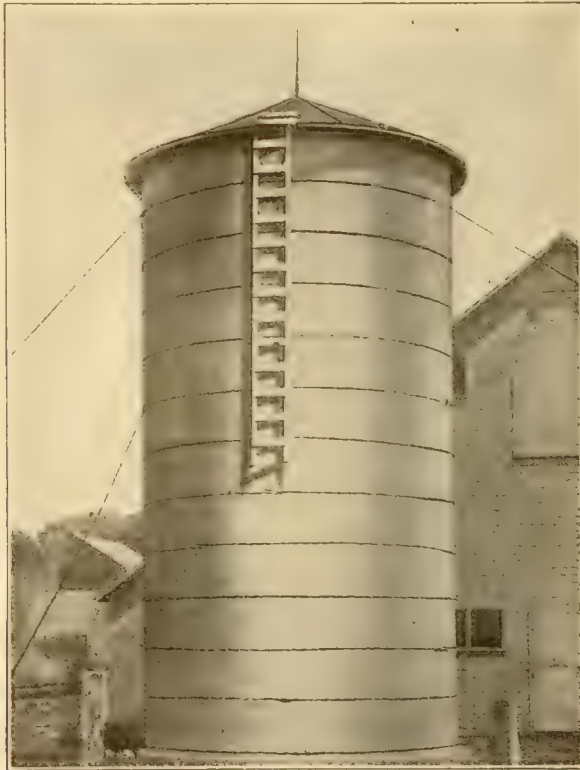

Fig. 14.—A Wooden Stave Silo Properly Constructed and Braced.

The first of these is what to look for in buying vitrified blocks. In some blocks there are little pebbles of limestone which can be plainly seen. After burning, these limestone pebbles absorb moisture and swell, chipping pieces off the blocks. Blocks which have such pebbles should never be used. In forcing some clays through the moulds the parts do not properly re-unite, and the end of the block has a stratified, or grained appearance where it should be smooth. This is a sign of weakness in the block, and all such blocks should be discarded. No blocks that are badly

checked or chipped should be used. If they must be put in, it should be at the top layers of blocks, where the pressure is least. But it is best not to use any inferior material. Only those blocks which are nearest the fire in burning are suitable for silos, and to secure them a reasonable charge for sorting must be paid above the standard price.

While all blocks have the glaze of vitrification, it is easily imitated, and by no means all bricks are really vitrified. The following is a convenient test for vitrified brick or blocks:

1. Place the block in an oven with the temperature above that of boiling water for forty-eight consecutive hours.

2. Weigh.



Fig. 15.—A Silo Which Was Not Properly Anchored, after a Storm.

Courtesy of the Iowa Experiment Station

3. Place the same block in water for another forty-eight hours.

4. Weigh again.

If the increase in weight of the block is more than five per cent of its dry weight, it has not been properly vitrified, and should under no conditions be used in the silo.

Devices of Construction—A few convenient devices in vitrified-block silo building are illustrated here.

Figure 16 shows a practical method of staging. The girders are nailed to the heavy central upright as shown, with their ends resting in holes

chipped out of the blocks. A new staging is built with each raise until the silo is completed. The staging is then in place for pointing up the

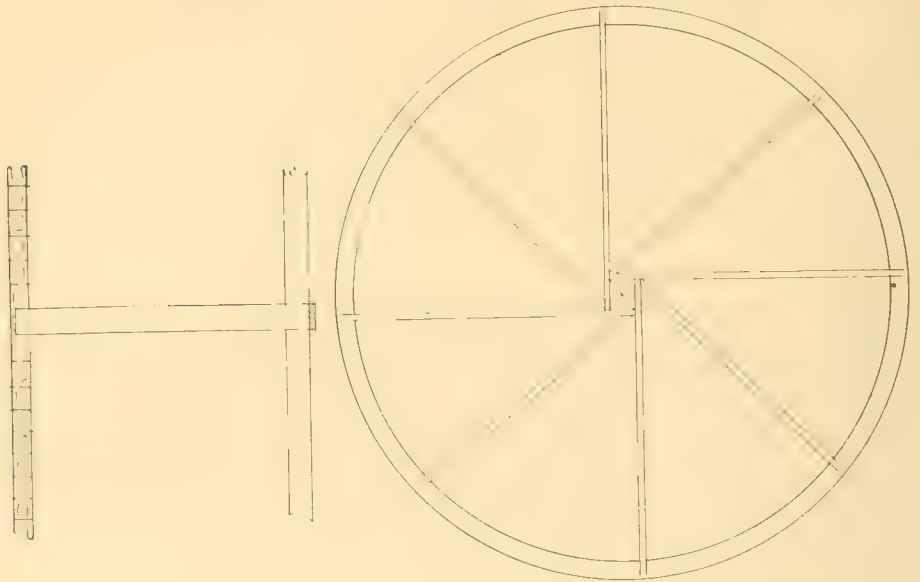
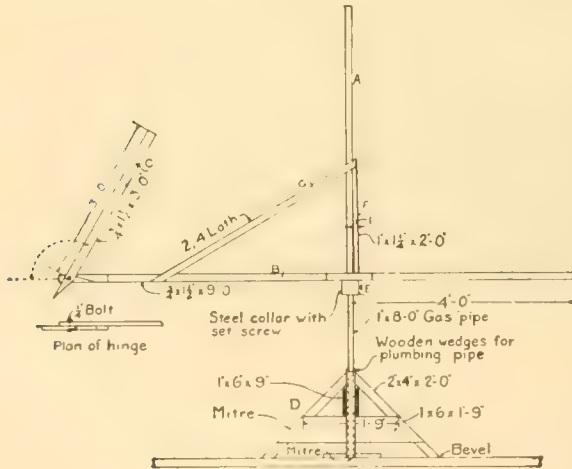

Fig. 16 STAGING FOR SILO

Courtesy of the Iowa Experiment Station

inner wall, and the holes are filled with cement as the staging is taken down.



GUIDE

For laying wall plumb and to a true circle.

Fig. 17

Courtesy of the Iowa Experiment Station

Figure 17 is a home-made guide for laying the wall in a true circle. A is a piece of $\frac{3}{4}$ -inch gas pipe eight feet long set perpendicular by the braces D. B is a light piece of lath, held horizontally by the brace C, and swinging about the pipe A, by means of a steel collar fastened to A by set-screws. B is hinged, so that it may not interfere with walking around the scaffold.

By laying each brick two inches from the end of the rod B a perfect circle will always be kept.

Fig. 18 shows the operation of the guide. The rod A must be set perpendicular with each shift. It must, moreover, be in the exact center of the silo. These are accomplished by dropping a plumb-line from the base of the pipe to a stake in the center of the silo floor, and getting the pipe, plumb-bob, and stake into alignment each time.

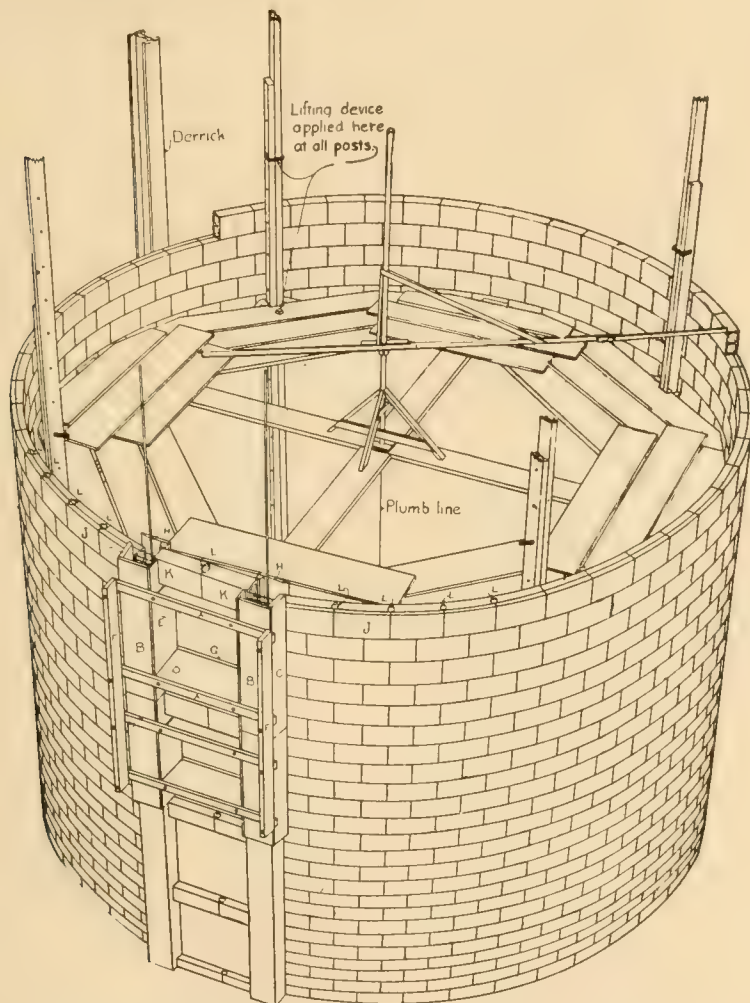
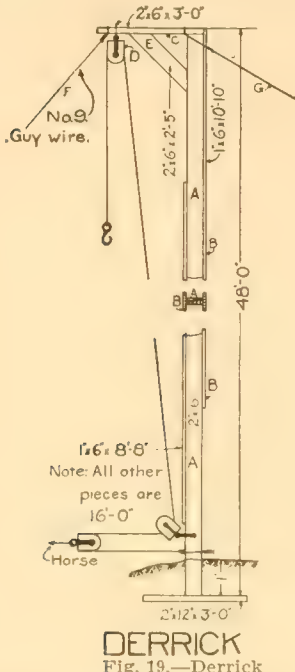

Fig. 18.—Scaffolding, Guide and Forms for Continuous Door.

Courtesy of the Iowa Experiment Station

Fig. 19 shows a convenient derrick. It is formed of the 2 x 6-inch piece A, and two 1 x 6-inch pieces B, forming the T-shaped upright which gives strongest construction. The T cross-piece at the top gives a good balance to the derrick, which can be made 40 feet high if necessary by simply splicing the timbers. It is best to have the derrick well guyed as shown in the diagram.

Foundations—There are two types of foundations which can be used with the block silo. The first is the simple concrete, which has already been discussed, and the second, or more common, is the block foundation.



Courtesy of the Iowa Experiment Station

The important thing to be remembered in making a block foundation is that the foundation blocks must not fill with water. Where the cavities in the vitrified or concrete blocks fill with water, it freezes in winter and shatters the whole foundation, often bringing the entire silo down, and always weakening it beyond repair. This can be prevented by putting drainage tiles around the outside of the foundation, or better, by filling up the foundation blocks solid with cement, standing them on end to do so. Fig. 20 shows the two methods in more detail. The Type 2 foundation, which is a combination of the concrete and block foundations, is by far the best one to use, as it combines all the good points of each.

Doors—There are two kinds of doorways in use with the block silo—the individual, and the continuous. Theoretically, the individual type

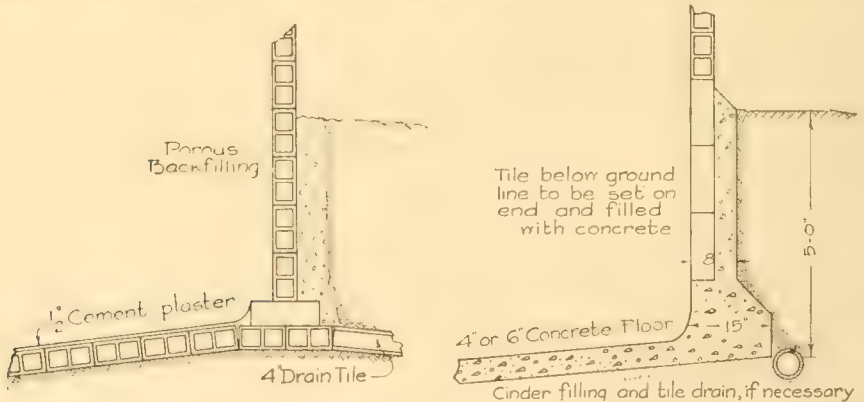

Fig. 20.—Type 1 Foundation at Left Constructed Entirely of Clay Blocks and Type 2 Foundation at Right Constructed of Blocks and Concrete.

Courtesy of the Iowa Experiment Station

is strongest, since the reinforcing can run in unbroken links for over half the silo's height, while in the continuous doorway, the reinforcing wires must be broken and tied to the upright reinforcement of the door frames.

The two types of doorways are illustrated in Figs. 21 and 22. In practice, however, one door frame is as strong as the other, when properly reinforced. Moreover, the continuous door has the advantage of having more open space, which means less labor in pitching silage into the chute.

It is not advisable to spend much time and labor in making forms, however, as they will probably not be used more than once. The mason probably will be provided with forms which he can bring with him.

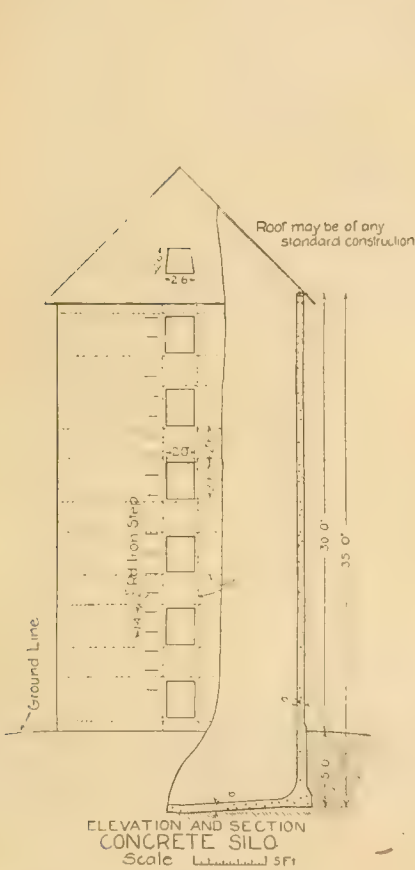

Fig. 21

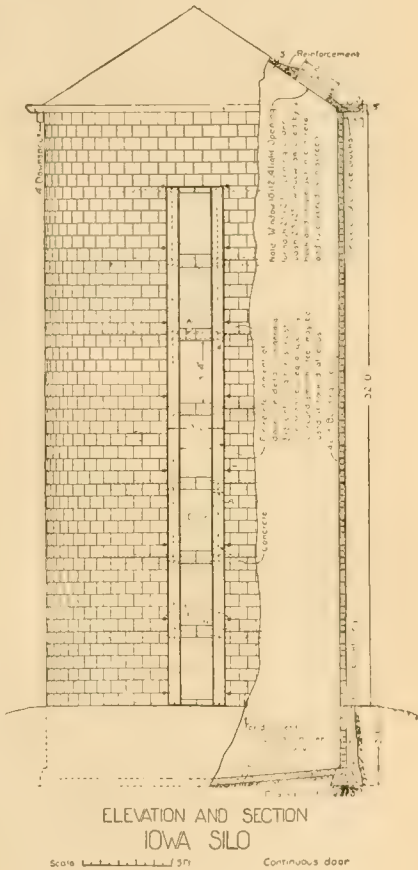

Fig. 22

Courtesy of the Iowa Experiment Station

Doors must be air-tight, and thick enough to prevent freezing about or through them. A good way to make a door is to nail flooring boards together as shown in Fig. 23, with good wall paper between. The continuous doors are practically the same in construction as the individual doors. Both should be two thicknesses of lumber and both have beveled edges to fit the inside of the doorway and be held in place by the pressure of the silage. Doors should be sealed with clay.

Reinforcement — Another thing which the farmer should thoroughly

understand is reinforcement. Nine out of every ten silos that crack or fall, do so because of the lack of reinforcement. Reinforcing should never be made with old and rusted out wire or rods. The silo isn't a scrap heap—it is a building in which one is investing good money.

It is better to use wires than rods in reinforcing, as rods are liable to slip in the concrete. The best kind of wire to use in the block silo is No. 3, which is one-fourth inch in diameter. This wire comes in coils, and is quite unmanageable unless some way is found for straightening it to the circumference of the silo.

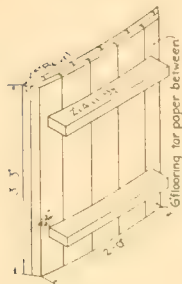

Fig. 23.—The Individual Type of Door

Figures 24 and 25 show a simple device for straightening wire which the farmer can make for himself and which will always be handy. The wire is slipped about a reel, and is drawn through a piece of gas pipe. After a few experiments the pipe can be bent so that the wire comes out with the proper curve.

The reinforcing wire should be laid in every other mortar joint, and should be completely covered with mortar to prevent rusting. The wires may be wound together in the joints, or if they are very heavy, hooked together by bending their ends into hooks. Where the continuous doorway is used, three-fourths inch gas pipe is run up the sides and the ends of the wires simply tied to the pipe before the mortar is poured for the frame. Figure 26 illustrates this clearly.

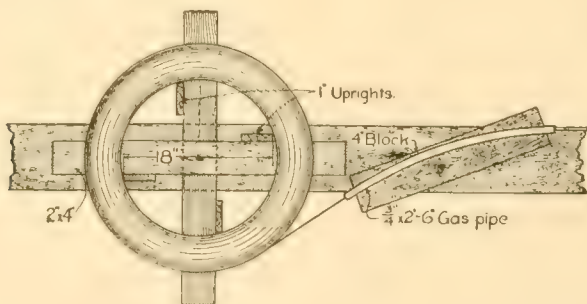

Fig. 24.—Reel and Device for Straightening Wire Reinforcement.

There are many rules laid down for the amount of reinforcement to be used in a silo, but most of them are complicated and difficult to remember. For No. 3 wire, three strands for the first ten feet, two strands for the next ten, and one strand for the last ten feet make sufficient reinforcement for a thirty foot silo sixteen feet in diameter. Remember that the greatest reinforcement should be at the bottom of the silo where the greatest pressure exists. For No. 9 wire, the number of strands ranges from five at the bottom to one at the top.

More definite rules will be given in Table No. 6, "Amount of Reinforcement Needed," at the end of this chapter. The top layers should



Fig. 25.—Showing method of straightening wire by drawing through a bent pipe.
Courtesy of the Iowa Experiment Station

always have a little reinforcement to prevent their spreading under the weight of the roof when green. Reinforcement is cheap. It is better to use too much than to use too little and lose an expensive silo.

The Roof—The roof of the vitrified block or cement silo should always be of concrete. A common way is to lay the concrete over the board frame and let it set. In all cases the frame is made the same as discussed under the hoop silo with this difference: the frame is not laid on the walls, but hung in with iron hooks as shown in Fig. 27, so that it can be removed after the cement has hardened. The sweep shown in Fig. 27 is hinged on a pivot at "A" and clears the sheeting boards by about two inches—the thickness of the roof. The proper way to make a cornice is also shown, laying the bricks endwise and breaking the outer one in half as shown. The cement is piled up at the top, and troweled and worked down evenly with the sweep "B," forming a gutter above the cornice. The top can be cemented over after the sweep is removed.

A better and more expensive way of building the concrete roof is to put expanded metal over the removable frame, as shown in Fig. 28. This forms a permanent reinforcement of the roof, and should always

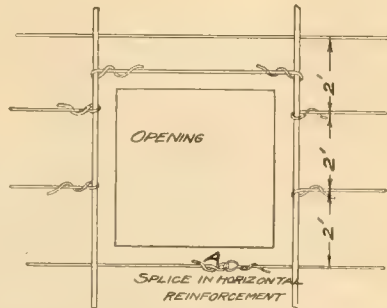

Fig. 26.—It is very essential that the reinforcement about the doorway is properly connected. Note how splices are made at A.

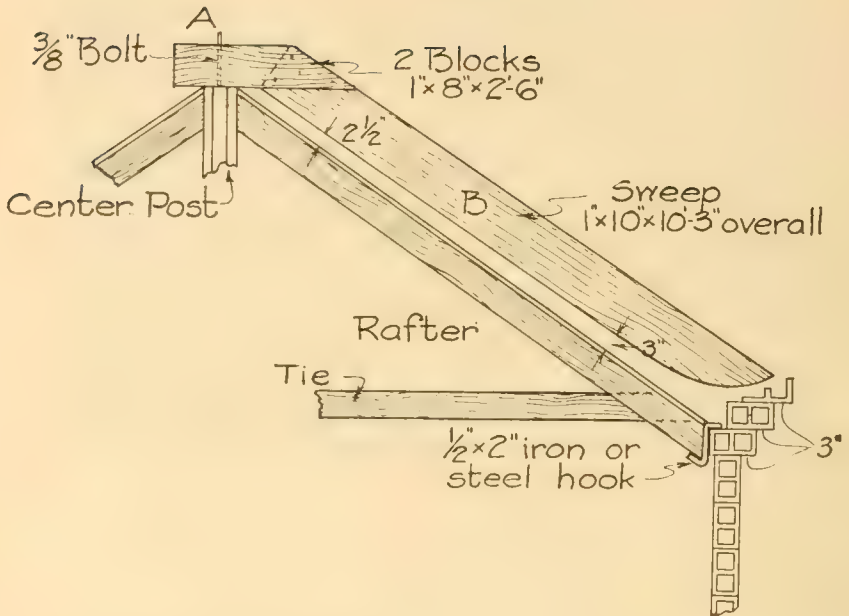

Fig. 27.—Sweep for Forming Concrete Roof.

Courtesy of the Iowa Experiment Station



Fig. 28.—Putting expanded metal on false work for concrete roof.

Courtesy of the Iowa Experiment Station

be made of some standard expanded metal. It is more difficult to construct, since it must be gone over with plaster from the inside to prevent rusting.

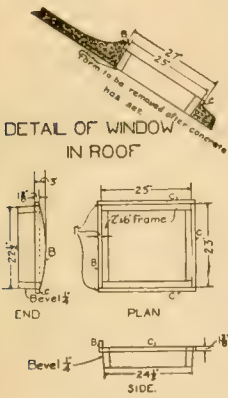

Fig. 29.—Detail of Form for Window

All cement roofs should be provided with a trap window of some kind. Fig. 29 shows the size and forms for making a good trap window in a cement roof.

Washing—After the walls have been made and before the staging has been taken down and preferably before the mortar is quite hardened, the whole inner wall ought to be gone over with a cement wash to seal any crevices or holes in the wall. Patent washes may not do. The best thing to use is a cement wash, of about the consistency of thick paint. It should be applied with a broom, as shown in Fig. 30.

THE CEMENT BLOCK SILO

It pays the farmer to make his own cement blocks for his silo. The best and quickest way to make the blocks is to buy a regular block-making machine, with interchangeable forms. Such a machine can be had for \$15, and is capable of turning out 150 blocks a day, either of the solid or of the air-space type. With two forms, the rounded for the silo blocks and a square form for ordinary blocks, the farmer will be able to make such a machine give good service on many kinds of work.

The next best way to make cement blocks is by the gang moulds. One of these is shown in Fig. 31. A long box is built, whose depth is the height of the silo blocks. Then a sufficient number of steel division plates to fill one gang are cut from No. 16 plate steel, and rolled to the curvature of the silo. These plates are spaced in the form by nailing blocks to the sides of the form. These steel dividing plates are wrapped in some coarse wrapping paper and placed in position in the form. The form is then filled with a wet mixture of concrete, and the paper, where it laps over the edge of the steel plate, is cut with a knife. Then the plates are removed and used again in filling another gang. The entire cost of such an outfit is only a few dollars, and several hundred blocks a day can be made by this method.

The gang mould, however, cannot make hollow cement blocks, and these are coming more and more in favor in silo building, because of the air space in the walls, which prevents freezing.

The construction of the hollow cement block silo is identical in all respects with that of the vitrified block type.



Fig. 30.—Applying the Wash.

Courtesy of the Iowa Experiment Station

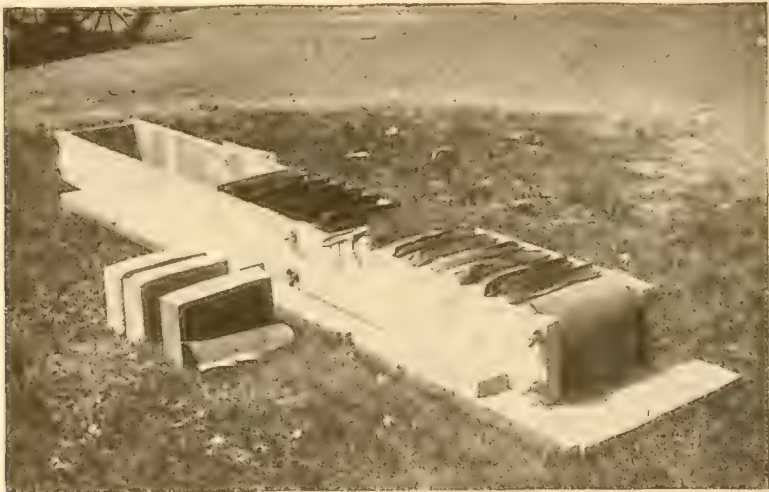

Fig. 31.—A Gang Mould for Making Concrete Silo Blocks with a Wet Mixture.

Courtesy of the Iowa Experiment Station

THE SOLID CEMENT SILO

A concrete silo cannot burn down, is ready to fill without repairing, never leaks, cannot blow over, and has no hoops to drop off. It costs little more than the best stave silos and often less than the concrete block, brick, or clay block silos.

No farmer should ever attempt to build a cement silo without the aid of a competent mason. In the first place, the farmer is simply wasting time making the forms, for they are even more complicated and harder to construct than the few forms used in the block silo. It takes more time and labor to construct the forms used in the cement silo than it takes to build the silo itself. And at the best the forms will be used only once or twice. In the second place, ignorance of some minor detail in mixing or the like, may ruin the whole silo. A good mason will come provided with the necessary forms and still more necessary experience. It pays to build well.

The Mixture — The proper mixture for a concrete silo is the so-called 1:2:4. That is, one part of cement, two parts of sand, and four parts of gravel or crushed stone by measure. It may be measured with the bottomless box shown in Fig. 32, and should be quite sloppy when poured, so that it will fill all the spaces in the mould. Concrete hardens within twenty or thirty minutes, hence it should be used at once when mixed.

Foundation — The foundation of the solid cement silo should be somewhat heavier than that of the stave or block silo, because of the greater weight of the walls. It should be about twenty inches wide, and reinforced through. The method of construction differs from the others because it is built up in the regular forms for making the walls.

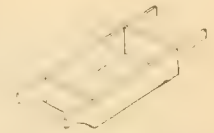

Fig. 32. — Measuring Box Used in Mixing Concrete

Reinforcing — The greatest pressure in the concrete silo comes upon the outside of the wall. For this reason all reinforcing should be within two inches of the outer edge of the wall. A good wire to use is No. 9, or heavier wire, such as No. 3. The amounts to be used will be found in Table No. 6, at the end of the chapter. It is not advisable to use cables, as they are elastic and allow the walls to crack. Three-fourths-inch gas pipe can be used for reinforcing the door frames, which are constructed the same as in the block silo. Fig. 33 shows a method of reinforcing that is often used, namely, wire fencing. It is more expensive than plain wires, and the advantage of so much reinforcing is doubtful. Fig. 26 illustrates the proper tying of the reinforcing wire to the upright reinforcing at the door.

Figures 35 and 36 show rather clearly how the forms for a concrete silo are set up. They are raised up the vertical uprights as layer after layer of concrete hardens. The outside form is an iron plate which extends

around the silo and is bolted together to give the wall the proper thickness.

The Roof—The roof should be of concrete, and has already been discussed under the heading of "The Vitrified Block Silo."

Care must be taken with both the block and solid concrete silos that they are not filled too soon after building. If filled before the mortar or cement has thoroughly hardened, the silos are sure to crack under

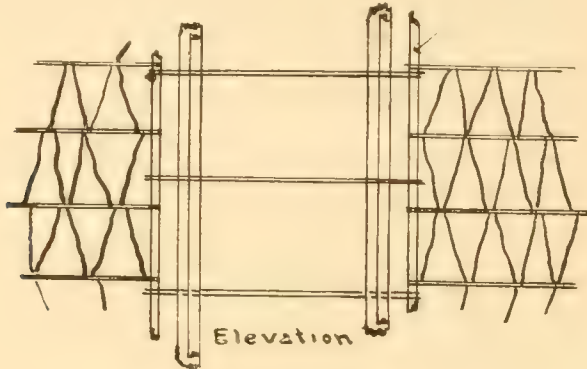

Fig. 33

the pressure. No silo should be filled within two weeks after building, except those made of wood.

THE PIT SILO

Pit silos are cheaply constructed and require little attention after building. They can be filled more easily than the ordinary silos, the ensilage never freezes in them, and if well constructed, they are more lasting than any other silo.

Location—The pit silo should never be located where the water

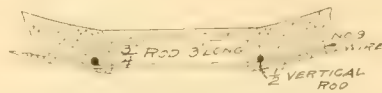
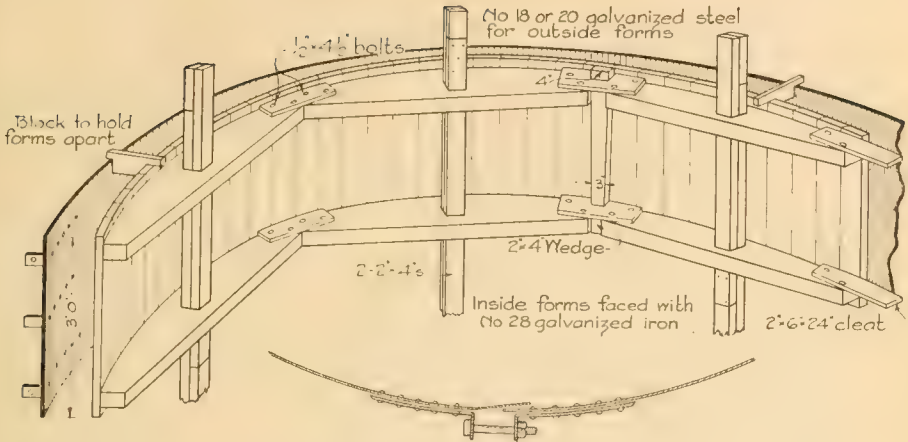

Fig. 34.—Vertical reinforcing should be used on each side of the door. The rods which act as a ladder and tie the vertical rods together should be $\frac{3}{4}$ inch in diameter and placed 2 feet apart. The horizontal reinforcement which passes around the silo connecting the vertical rods should be either No. 9 wire or $\frac{3}{8}$ -inch mild steel rods. It is important that the door should be well reinforced.

level is not some ten feet or more below the desired depth of the silo. This is one reason why the pit silo is more popular in the semi-arid West than elsewhere. In rainy climates, seepage through the walls of the silo will give trouble.

Construction—To build a pit silo in soil which will not give trouble from caving, lay out a circle on the ground the desired size of the silo, and outside of this circle dig a trench which should be deep enough to extend below frost and eight inches wide. The inside of this trench should be smooth and perpendicular. Fill the trench with a concrete mixture of 1 part cement and 5 parts sand or gravel, well mixed and very wet.



Connection in Outside Form
 Fig. 35.—Concrete Silo Forms. Details

Courtesy of the Iowa Experiment Station

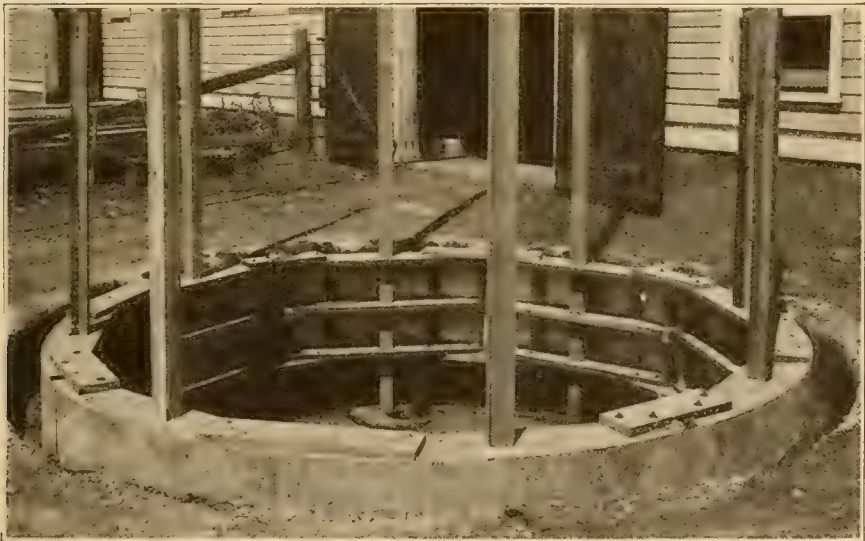

Fig. 36.—Two pieces of 2x4 are used to keep each section of the silo forms perfectly plumb. The inside form is shown here in position after the first filling. It is now ready for the second filling which should bring the concrete to the ground level.

Courtesy of the Wisconsin Experiment Station

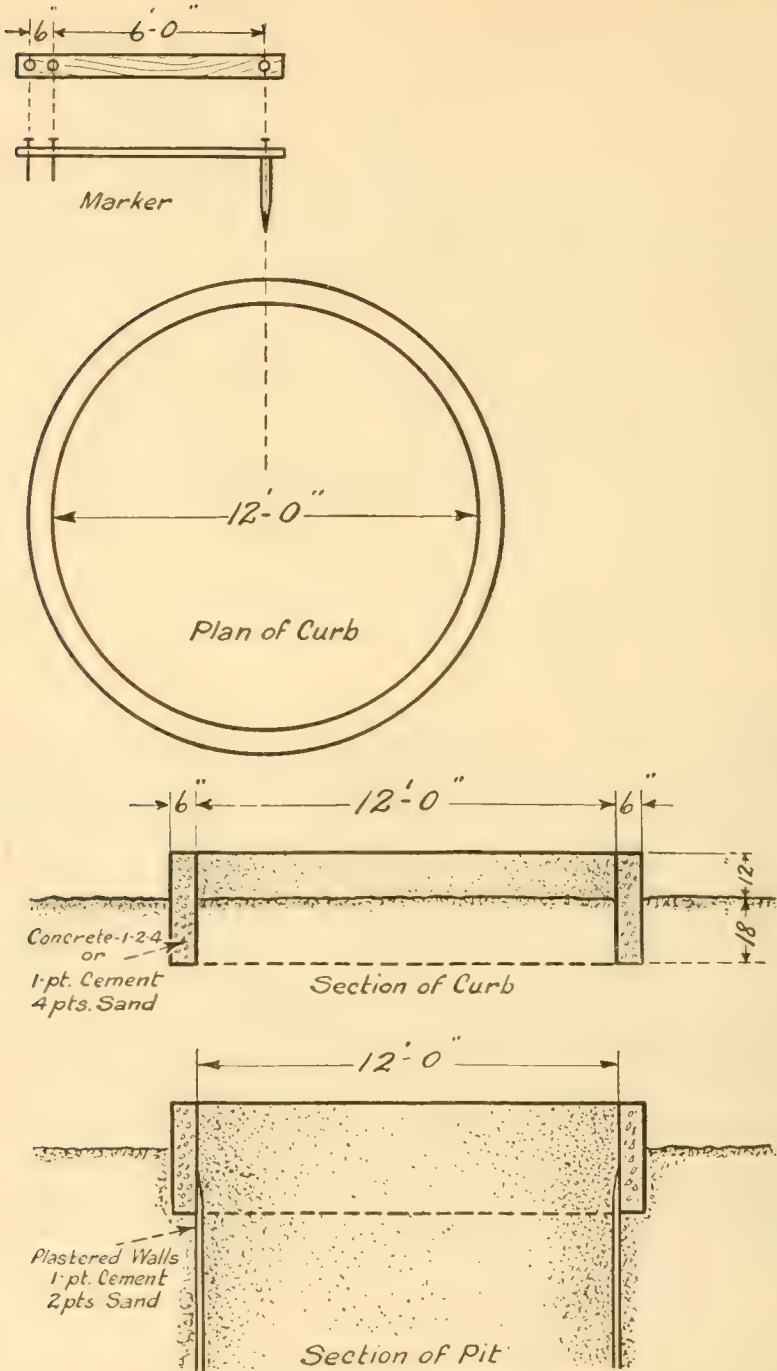

Fig. 37.—Plans for Constructing a Pit Silo. "Marker," used for laying out surface pattern. "Plan of Curb," showing diameter of silo, thickness of concrete at top and bottom of curb. "Section of Curb," showing dimensions of concrete curb. "Section of Pit," showing silo pit, position of curb, walls of silo, etc.

When this outside rim has set, go inside and excavate to a depth of about six feet below the rim. The rim will prevent cave-ins. Keep the walls plumb and smooth so that it will not require too much mortar for plastering. A good way to do this is to drill a perpendicular hole in the exact center of the silo and set a gas pipe in the hole to serve as a pivot. Be sure that the gas pipe is perpendicular. Now bore a hole near the end of a 2 x 4 scantling and place it over the gas pipe. Saw the other end off so that its length from the gas pipe will be the radius of the silo. Bolt some good heavy blade on this end. The walls can be trimmed perfectly smooth with this device.

The trimming should be kept well up with the digging to prevent throwing the dirt out from a greater depth. After the excavation has been completed, the sides of the silo should be plastered with cement to prevent the earth from caving in.

This plaster should be made of one part cement and two and a half parts sand. Before it is put on, the walls should be dampened with a spray pump or an old broom. Then the first coat can be put on with a trowel.

Immediately afterwards the second coat of plaster may be put on. Two coats are enough in heavy clay soil, but on light and sandy soils three, four and even five coats of plaster will be required. The thicker the wall is plastered, the closer the silo will approach being everlasting.

To save scaffolding and avoid the caving in of the walls, it is best to plaster each section six feet deep before digging further. As soon as one section is plastered the next can be dug and plastered. It is not advisable, however, to go more than twenty feet deep.

After the silo has been completed the collar at the top should be extended at least one foot above the ground level to prevent the surface water from running into the silo and to keep the stock from falling in. This can be done by building it up with concrete bricks. Where stock is allowed to run around the silo, it is well to build the silo up four or five feet above the ground, so that they cannot reach after the silage and fall in. The walls should not be built higher though, for then it would be difficult to take the silage out with the block and tackle. The dirt may be graded up around the silo to prevent the water from forming a puddle about it.

Removing Silage — For a small herd, where the silo is near the place of feeding, a handover pulley with a rope and two baskets is all that is necessary. Each basket should hold enough silage for two cows. With a hook at each end of the pulley rope, one basket of silage can be raised while the other empty basket is lowered.

For a greater number of stock, a large box, holding from 400 to 500 pounds of silage should be used. This must be raised by means of a block and tackle and a windlass. The bottom of the box should open

on hinges and let the silage fall into a trough or wagon. An elevated track, such as a hay fork track, can be arranged to carry the silage to the feed troughs.

CONCLUSION

Each silo has its advantages. The wooden stave silo can be moved easily, and its cost is low. The block silos can be built in a very short time, and do not require an expert in construction. The concrete silos are the most durable, their cost is low, and their maintenance cost negligible. Each has also its disadvantages. The wooden stave silo causes endless trouble in loosening and tightening staves, and is bound to rot sooner or later. The concrete silo requires an expert to build it, and takes several more days in construction than any other type. The cement silo is rapidly gaining in favor, because it is durable and fire-proof, and not so expensive as the block silo. In the dry regions of the semi-arid West the small farmer will find the pit silo a very practical proposition. The farmer must choose which of the types he can best construct according to his means and the conditions under which he works. But he should get the most efficient silo obtainable for his money, and accept no imitations.

TABLES FOR SILO CONSTRUCTION

TABLE No. 1
RELATION OF SIZE OF SILO TO SILAGE TO BE USED DAILY

Number of cows	Silage for 180 days at 30 lbs. per day		SIZE OF SILO		Silage for 240 days at 30 lbs. per day		SIZE OF SILO	
	Tons	Acres	Inside diameter	Depth of silage	Tons	Acres	Inside diameter	Depth of silage
			Feet	Feet			Feet	Feet
14	38	2 to 3	10	26	50	3 to 3½	10	32
15	40	3 to 3½	10	28	54	3½ to 4	10	33
20	54	3½ to 4	12	26	72	4½ to 5	12	32
25	68	4 to 5	14	26	90	6	14	31
30	81	5 to 6	14	28	108	7 to 8	14	34
35	95	6 to 7	16	26	126	8 to 9	16	32
40	108	7 to 8	16	28	144	9 to 10	18	29
45	122	8 to 9	18	26	162	10 to 11	18	32
50	136	9 to 10	20	26	180	11 to 12	20	30

It does not pay to build a silo for less than 10 head of cows, but it would probably be better to build the silo and then purchase more cows. In the foregoing table the smallest silo considered has a capacity of 38 tons capacity of furnishing succulent feed for 14 cows for 180 days. During the average season 10 cows consume the greater portion of the silage from a silo of this size.

TABLE No. 2
CAPACITY OF SILOS OF VARIOUS DIMENSIONS

Depth of Silage Feet	Inside Diameter of Silo in Feet							
	10	12	14	16	18	20	22	24
	Tons	Tons	Tons	Tons	Tons	Tons	Tons	Tons
25	36	52	68	96	122	136	173	206
28	40	61	81	108	137	160	205	245
30	44	68	90	115	150	180	226	270
32	50	72	95	126	162	200	248	295
34	53	77	108	142	171	223	269	313
36	57	82	114	158	194	230	290	341

TABLE No. 3
MATERIALS FOR ONE CUBIC YARD CONCRETE

	Mixture 1—2—4	Mixture 1—2½—5
Bbls. cement per cubic yard of concrete.....	1.3	1.07
Cubic yards sand per cubic yard of concrete.....	.42	.44
Cubic yards stone per cubic yard of concrete.....	.84	.88

In order to determine the amount of cement necessary for any amount of concrete, estimate the number of cubic yards and multiply that number by the figure in the table opposite, "Bbls. cement per cu. yd. of concrete," and under mixture to be used. The amount of sand and of stone is determined in the same way.

TABLE No. 4
MATERIALS FOR A 14-FOOT CONCRETE SILO

The following is a bill of materials for a concrete silo 14 feet in diameter inside and 36 feet high with concrete roof.

MIXTURE 1—2½—5

Silo Parts	Cement barrels	Sand cubic yards	Gravel cubic yards	Concrete cubic yards
Foundation footings.....	1.87	.77	1.54	1.75
Floor.....	2.67	1.1	2.2	2.5
Foundation wall 4 ft. high.....	7.46	3.07	6.14	6.98
Wall 32 ft. high.....	28.99	11.92	23.74	37.1
Roof.....	3.21	1.32	2.64	3.0
Total.....	44.2	18.18	26.22	51.33

Note—If the sand and gravel are clean and care is exercised in mixing, a 1—2½—5 mixture is sufficient. If not, use a 1—2—4 mixture, in which case add 7 barrels of cement, 1 cubic yard sand, and 1.1 cubic yards gravel.

TABLE No. 5
COST PER FOOT IN HEIGHT OF SILOS

Mixture to be 1 part cement, 2½ parts sand, 5 parts gravel and wall to be 6 inches thick.

Diameter Feet	Cement Barrels	Sand Cubic yards	Gravel Cubic yards
10.....	.65	.269	.538
12.....	.778	.32	.642
14.....	.903	.372	.74
16.....	1.03	.422	.844
18.....	1.16	.475	.95
20.....	1.27	.525	1.05
22.....	1.4	.576	1.15

TABLE No. 6
AMOUNT OF REINFORCEMENT NEEDED FOR SILOS
Size and Spacing of Horizontal Reinforcement Around Silo

Distance in feet measured from top of silo	For silos 14 ft. to 18 ft. in diameter, using No. 9 wire		For silos 14 ft. to 18 ft. in diameter using 3/8 inch mild steel rods	
	No. of wires in cable	Distance apart of cables	No. of rods	Distance apart of rods
		Inches		Inches
0—5.....	2	12	1	18
5—10.....	2	10	1	18
10—15.....	2	8	1	14
15—20.....	4	8	1	12
20—25.....	4	6	1	10
25—30.....	4	6	1	8
30—35.....	5	6	1	6
35—40.....	5	4	1	4

TABLE No. 7
VERTICAL REINFORCEMENT

Height of silo in feet	For Silos 14 ft. to 18 ft. diameter			
	No. of wires in each cable	Distance apart of cables	No. of rods	Distance apart of rods
		Inches		Inches
25—30.....	4	24	1	30
30—35.....	6	24	1	20
35—40.....	8	24	1	14

Note—Silos 25 feet high and 14 to 16 feet or less in diameter need no vertical reinforcement.

TABLE No. 8
COST OF CONSTRUCTING VARIOUS TYPES WOODEN SILO

No.	Size	Capacity	Kind	Cost	Other Material	Labor	Total Cost	Cost Ton Cap.
1	16x36	155	Stave	\$130.12	\$47.80	\$50.87	\$228.78	\$1.47
2	14x28	83	Panel	275.00	63.00	40.00	378.00	4.55
3	14x32	100	Stave	203.75	103.62	307.38	3.10
4	14x30	91	Stave	179.42	125.28	304.70	3.31
5	16x37	161	Stave	394.00	135.25	77.00	607.75	4.07
6	14x23	83	Stave	156.52	96.63	72.80	325.95	3.92
7	16x32	131	Panel	265.00	8.00	132.00	405.00	3.09
8	14x28	83	Stave	257.00	15.00	16.00	288.00	3.39
9	16x26	97	Panel	280.00	16.00	54.00	350.00	3.50
10	18x29	114	Panel	350.00	50.00	400.00	2.77
Average Cost and Cost per Ton Capacity							\$359.55	\$3.32

The object in compiling the data in tables 8, 9 and 10 is to show the size, kind and cost of material, the cost of labor and the relative cost of the silo per ton capacity. The data compiled was obtained first hand from farmers throughout the Northwest who are using these various types of silos.

The above table includes data on homemade and patent wooden silos. In some instances considerable of the material used in making the roof, the chutes and staging were already on the farm which materially reduced the cost, while in other cases the silo company furnished all

of the material. In some instances the farmer was not obliged to hire any outside help and thus saved largely on the cash cost of construction.

TABLE No. 9.
HOLLOW BLOCK SILO

No.	Size	Cap.	Cost Blocks	Bags Cement	Cost	Other Material	Reinforcement	Cost	Labor	Total Cost	Cost Ton, Cap.
1	17x35	168	\$ 81.00	148	\$53.28	\$69.50		\$17.50	\$266.30	\$525.03	\$3.33
2	14x34	109	160.67	60	30.00	43.60		12.03	98.65	344.95	3.16
3	14x40	138	140.00	80	27.50	94.44	Old Rods Iron Wire	11.00	103.45	375.39	2.70
4	16x37	161	179.25	56	22.00	33.28		14.00	90.63	329.16	2.28
5	15x44	184	142.70	..	60.00	25.00		12.00	108.00	347.70	2.23
6	14x37	123	90.70	40	24.75	11.60	Wire	11.60	102.20	239.85	1.95
7	16x35	149	148.75	100	37.79	41.50	Wire	13.75	115.00	356.79	2.39
8	14x38	128	98.00	50	22.50	25.30	Rods	12.20	60.00	218.20	1.70
Average Cost and Cost per Ton Capacity										\$343.13	\$2.46

The data in this table includes only that of hollow clay blocks, no data on cement blocks being included.

TABLE No. 10
MONOLITHIC OR SOLID CONCRETE SILO

No.	Size	Cap.	Bags Cement	Cost	Sand and Gravel	Other Material	Forms	Reinforcements	Labor	Total Cost	Cost Ton Cap.
1	16x33	143	208	\$04.00	\$45.10	\$ 9.85	\$79.50	Wire and Iron	\$132.48	\$370.93	\$2.17
2	14x31	96	152	98.80	45.50	34.25	37.62	Wire	92.70	409.97	3.22
3	16x34	143	156	87.90	94.50	44.75	Wire	104.00	331.15	2.31
4	16x31	125	196	22.50	5.00	55.45	49.50	Wire	154.00	396.45	3.09
5	14x32	100	132	86.00	102.00	55.17	33.50	Wire	87.00	365.67	3.63
6	16x24	87	168	135.20	93.00	Wire	90.00	318.20	3.65
Average Cost and Cost per Ton Capacity										\$365.39	\$3.12

CHAPTER V

THE BEEF CATTLE BARN

- I. PLANS—No. 1, WITH CENTRAL FEEDING ALLEY—No. 2—No. 3—WITH OPEN SHED.
 II. REQUIREMENTS OF A GOOD BARN.

The beef cattle barn does not differ materially from the dairy barn in its main features. Figures 1-3 show some excellent plans for beef barns.

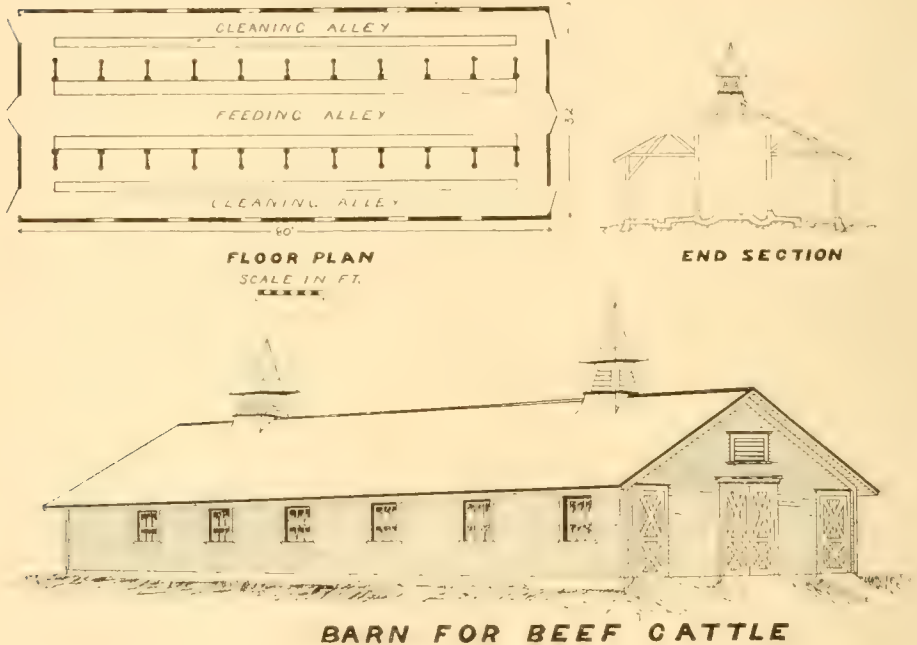

Fig. 1

Courtesy of the North Dakota Agricultural Experiment Station.

Perhaps the simplest form of barn is that shown in Fig. 1. This has a central feed alley, with two rows of stalls and two manure alleys arranged the same as the best dairy barns. The cement floor is laid just the same as the floor in the dairy barn, with the feed floor at the highest level and the manure alleys at the lowest. Beef barns are rarely provided with a hay loft, although one can be put in by making a gambrel or hip roof. The common method of feeding is to carry the feed into the central passage on a wagon and pitch it into the mangers. For

this reason the central alley and end doors should not be less than eight feet wide.

Many farmers prefer to raise their beef cattle rather than to buy and fatten them for market. Figure 2 shows a good barn for such an estab-

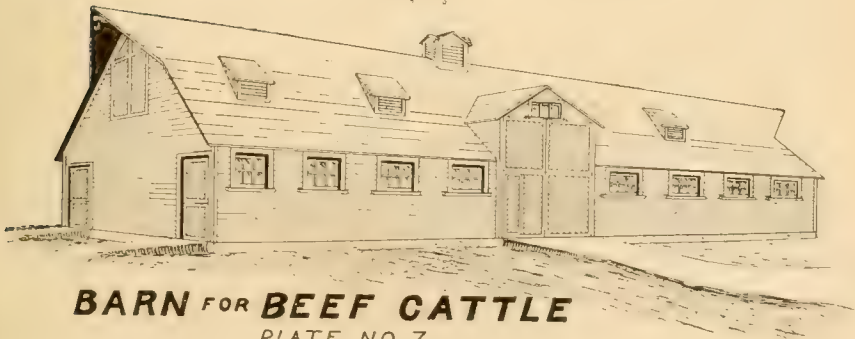
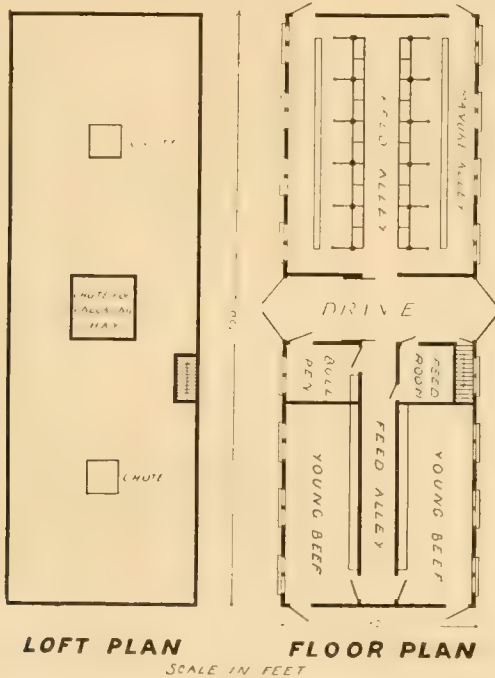

Fig. 2

Courtesy of the North Dakota Experiment Station

lishment. This has the overhead hay loft and grain bins, which are found in most dairy barns. The mixing room is important, and should be placed just beneath the grain bins.

Windows are important in the beef industry, and should be exceptionally large. Ventilation should always be the King system, but need

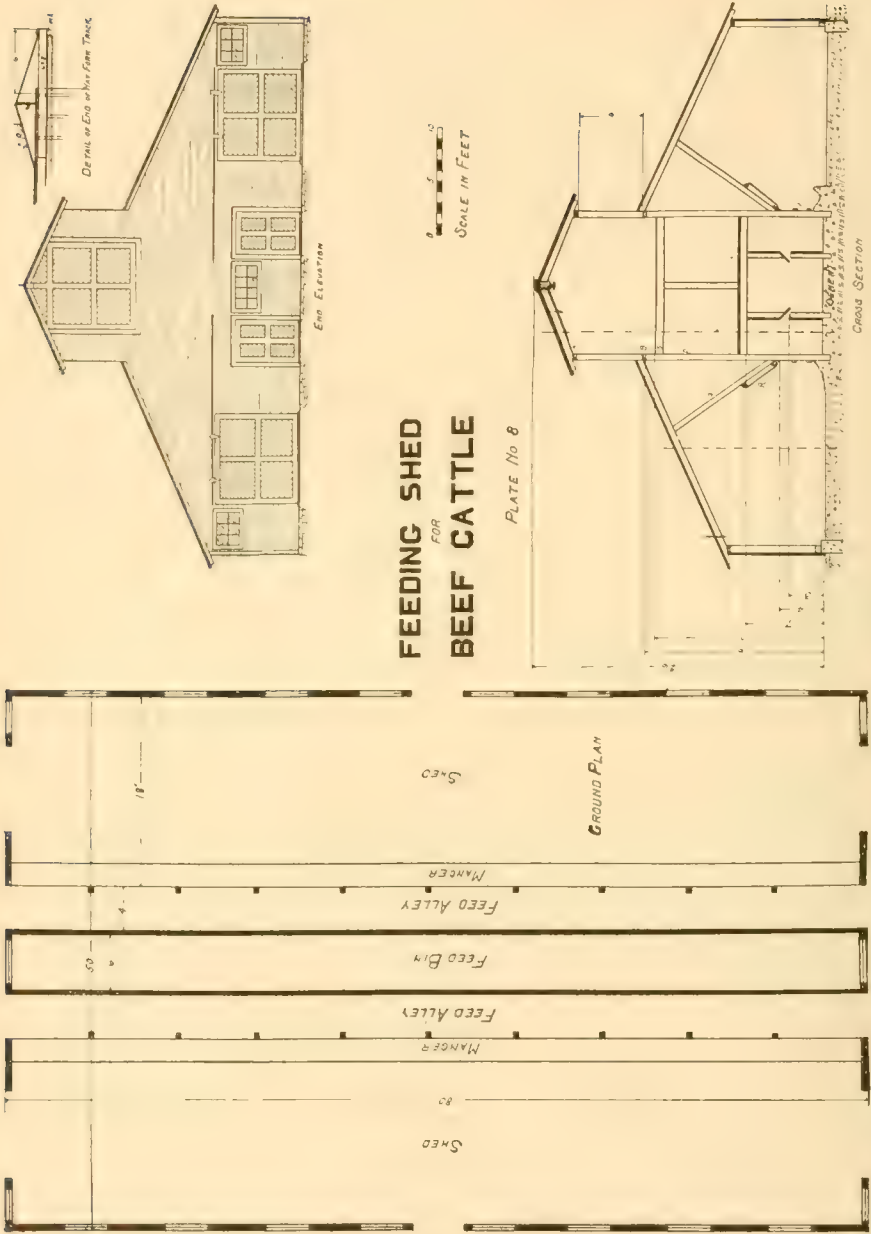

Fig. 3

Courtesy of the North Dakota Experiment Station

not be so carefully installed as in the dairy barn, as beef cattle are not so responsive to lack of ventilation.

In temperate climates it does not pay to build a beef cattle barn. There the open shed method of feeding is universally practised with good results. Fig. 3 shows a good type of open shed.

Here the cattle are not confined to stanchions at all, but are free to come and go about the building. There are two long mangers and a central feeding alley from which hay can be fed. The floors are of dirt, and manure is removed by means of a wagon. The mangers and feed floor are made of concrete, and the building is very inexpensive and not quite so sanitary as it might be. Sanitation is, however, of relatively minor importance in the beef industry.

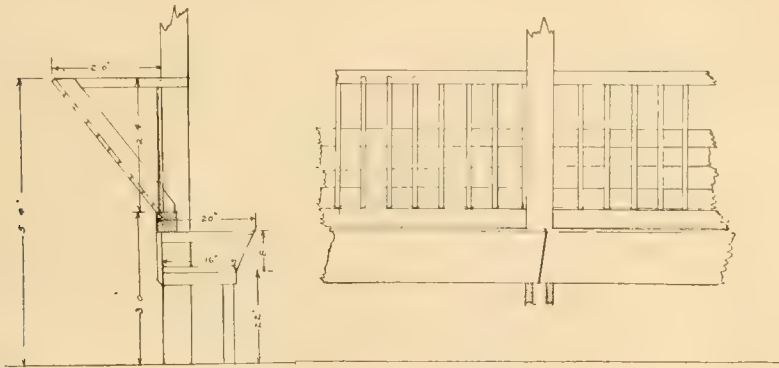

FIG. 4.—An Outdoor Feeding Rack.

In the South and West, feeding is largely done from the outdoor manger and the cattle are not confined at all. This is a good practice in climates which are moderate enough, as it serves the purpose of a building and costs scarcely anything. Figure 4 shows such an open feed rack.

Care must be taken to pave the ground about an open feed rack with a stone or cement floor, as the cattle are apt to make a bog around it in wet weather, and this becomes a spreader of disease.

A good beef cattle barn should be warm, ventilated, and convenient for feeding. It need not be so carefully constructed as a dairy barn, as dust and sanitation are unimportant factors, compared to the dairy industry. It should, however, be reasonably clean and well lighted, and should properly house the greatest number of animals for the least cost. In other words, it should be efficient.

CHAPTER VI.

THE HORSE BARN

I. INTRODUCTION. II. ARRANGEMENT—PLAN No. 1. III. DETAILS OF CONSTRUCTION —FLOORS—CEILINGS—LIGHTING—VENTILATION—WALLS—STALLS.

The best and most economical type of construction on small farms is to combine the horse barn and the dairy barn in one building. This is not objectionable when the horses and cattle occupy distinctly separate quarters. But on large farms, and on farms devoted to dairying, a single structure for both horses and cattle assumes such vast proportions that it will cost less to build two separate buildings. In several states it is not lawful to keep horses in dairy barns. With separate buildings there is less danger of loss from storms, lightning, and fire.

Horses require light, airy and dry shelter, and are too valuable to be housed in buildings which do not meet these requirements. Horses, shut up in dungeons without light or ventilation, cannot be expected to come out of such quarters in good condition for work, any more than a human being could when so treated. The horse barn must be sanitary and the stalls comfortable if the best results are to be obtained.

Arrangement—Fig. 1 shows a well arranged horse barn. There are three features of this plan that should be embodied in every horse barn: the separate carriage room, the central alley, and the separate harness room. It is best to have the spouts from the feed bins lead into a separate mixing room. In Fig. 1 a part of the carriage room has been turned into the mixing room, the spouts running down the walls on either side. This arrangement is not quite so convenient as a separate room would be. The harness room is essential, for leather should be protected from the fumes of the manure and from the accumulation of dust. Shut up in a separate room, the harnesses will not have to be cleaned each time they are put on. The wash floor shown in the carriage room is very convenient. The cement floors slope toward a central drain, which keeps the floor dry when washing.

Floors—The floors of a horse barn should always be cement, as they are sanitary and easily cleaned, and more durable than wood. The floors of stalls should have a slope of 1 inch to 6 feet and should be grooved or roughened to prevent slipping. If preferred, wooden floors can be laid over the cement stall floors, but they must be so arranged that they can be removed and cleaned each week.

Ceilings—While it is not so important to have tight ceilings as in

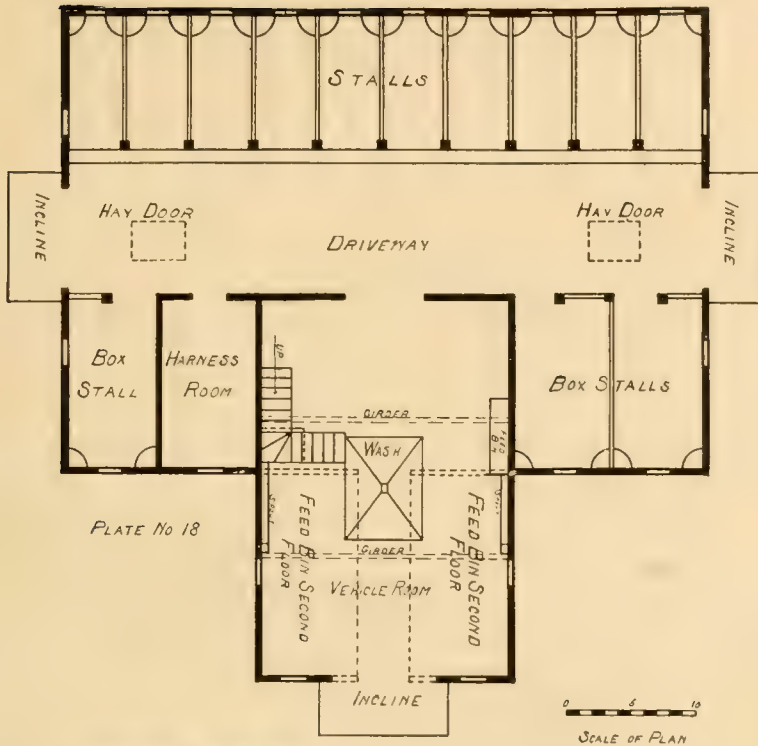

HORSE BARN

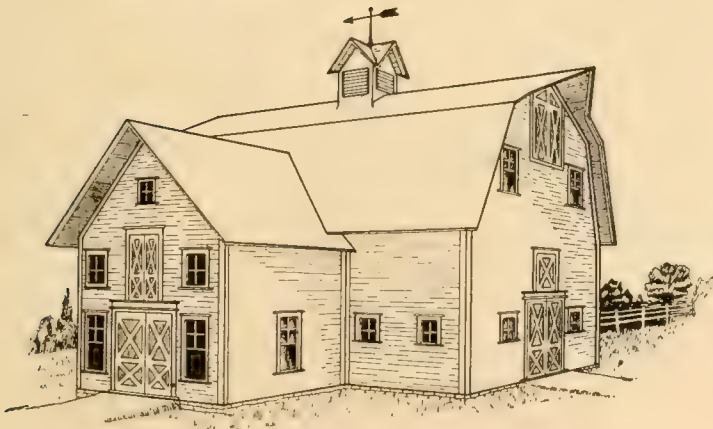

Fig. 1

Courtesy of the North Dakota Experiment Station

the dairy barn, yet all ceilings ought to be made of tongued and grooved flooring, for the continual sifting of dust upon the horses will make a great deal of labor in cleaning, and keep the barn continually dirty. For this reason the hay chutes in the central alley should extend down to the floor.

Lighting — Horse barns are usually deficient in light. Horses should have just as much, if not more light, than dairy cows. One 3 x 3-foot window should be provided for every stall, and it should always be low enough for the horse to look out. The doors of box stalls should also be cut in halves, so that the upper part may be swung back and allow the horse to look out. Nothing adds more to a horse's contentment than the ability to see what is going on about it.

Ventilation — The King method of ventilation is, of course, resorted to. The number of flues to be constructed can be figured out from the formulas under "Ventilation" in Chapter III "The Dairy Barn."

Walls — These must, of course, be built tight to prevent any draughts from interfering with the system.

Stalls — The ideal way of housing horses is in box stalls. But as they require about three times as much room as ordinary stalls, they should only be provided for carriage and riding horses. Box stalls should be about 10 feet wide by 12 long. The walls should be smooth so that the animals cannot rub their tails and manes. A 2 x 6, placed horizontally against the wall of the stall below the height of the mane and tail, with its edges smooth and rounded, will prevent rubbing, and is widely resorted to. The stalls are provided with iron corner racks for hay and feed, with shallow mangers beneath them to prevent waste. The feeding is best done in box stalls by individual hay and feed chutes for each stall.

The ordinary horse stall does not differ essentially from the wooden cow stall. It should be made of wood, set upon ridges in the concrete floor if desired, to prevent the rotting out of the board edges. The size should be somewhat larger than the cow stall, about 6 feet long and 3 feet 6 inches wide.

Conclusion — In building a horse barn, the farmer should be guided by his own needs. Convenience, sanitation, and contentment on the part of the animals are the three things to strive for in building any barn. While the dairy barn represents the ideal in barn construction the horse barn should by no means be neglected.



Figure 1: Floor plan of a building.

CHAPTER VII

THE COMBINATION BARN

I. REQUIREMENTS. II. PLANS—No. 1—No. 2—No. 3.

While it is sometimes necessary to build separate barns for horses and cattle on large farms, and while many breeders follow this practice, the average farmer will find some form of combination barn cheaper and more convenient.

Such a barn, however, should keep the animals separate as much as possible, and must be convenient. Some of the most awkwardly arranged barns to be seen are the result of clumsy attempts at combination, and half the values of the combination barn is immediately lost if it compels the hired man to take twice as many steps as necessary.

If one keeps in mind the ideals of dairy-barn construction—the central driveway, the central feed room, and straight racks for the manure and feed carriers, he will not get tangled up in a combination barn plan. The quickest way to get work done is to arrange it in a straight line; and that is the way the barn should be planned, with horse stalls in one straight line, all cow stalls in another, and the feed room and silo at their juncture.

The blue print shows a simple manner of making a combination barn. A partition is run down the center of the barn, with the hay chutes running down it and opening on either side. Cow stalls and pens are all placed on one side of the partition, and horse stalls on the other. This manner of construction can be effectively used in remodeling an old barn.

Fig. 2 shows another way of arranging a rectangular barn. A partition is thrown across one end, with the width of a drive between the horses and cattle. This makes a good separation, but takes up space. By making the drive wider, it can be used as a carriage room.

It might be convenient to put the silo at the side in this barn, placing the mixing room at the head of the alley between the horse and cattle stalls. The general arrangement is not perfect in any plan—the farmer must get as many good points as he can into his barn.

Fig. 3 shows a common and very good type of combination barn. The horses occupy one wing and the cattle the other. It is simply a horse barn and a cow barn moved up against each other, as shown. This is very convenient for feeding, and filling the mows and caring for the animals. By shifting the horse stalls to the right and putting the feed bins and mixing room up in the corner by the silo, one can have a common feed bin and

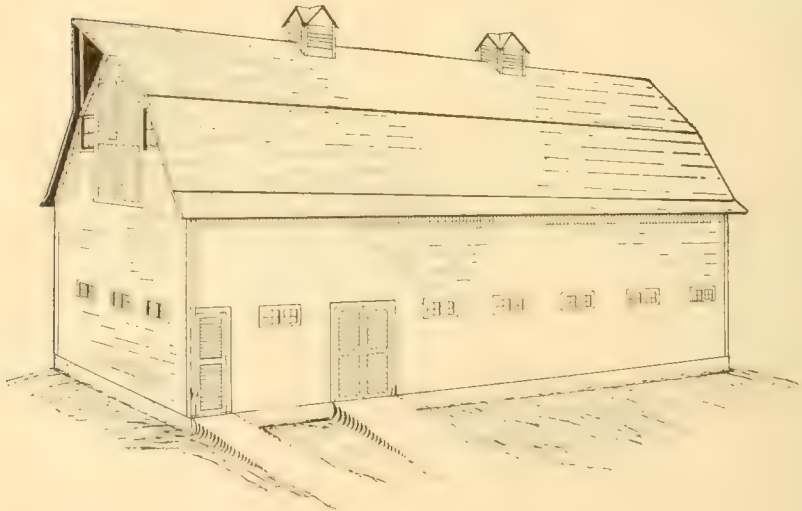
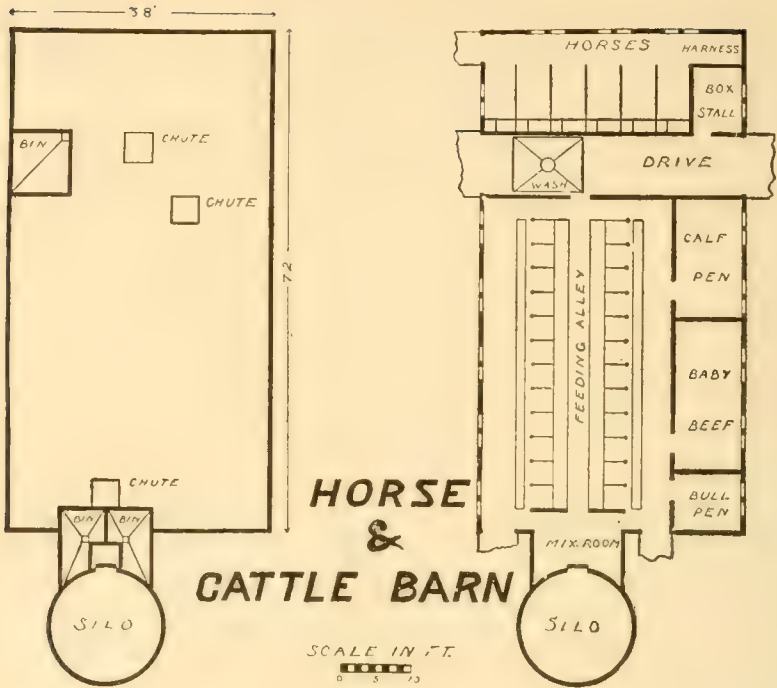
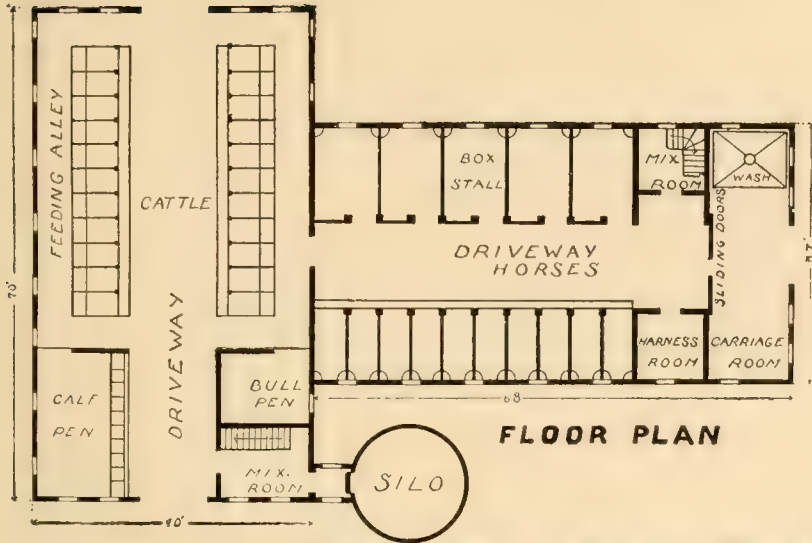

Fig. 2

Courtesy of the North Dakota Experiment Station



FLOOR PLAN

HORSE & CATTLE BARN

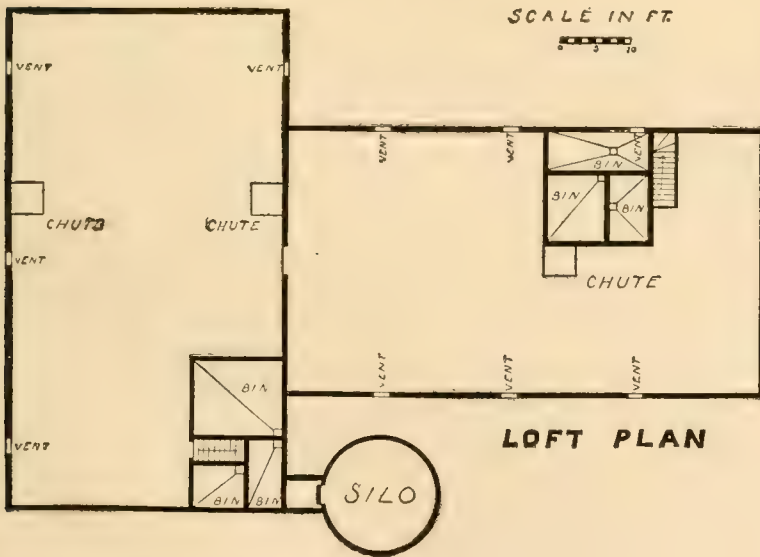

LOFT PLAN

Fig. 3

mixing room arrangement which will do for both horses and cattle and save time and labor. As the plan now stands, two separate sets of bins must be filled in different parts of the building, and space allowed for two separate mixing rooms, one of which is unnecessary. Still, the arrangement is very good as it stands, convenient, and with the animals properly separated.

So much has already been said in regard to the dairy barn and the horse barn that repetition would be needless. The same constructions are used for the combination barn as for the separate barns; the same laws of ventilation, lighting and sanitation hold for both.

In giving these plans for the combination barn it is not expected that they will be followed exactly, although they are practical working models. They are merely used to illustrate some of the methods of securing proper separation and convenience at the same time. A combination barn is nothing more than a dairy and a horse barn joined together in the most convenient manner.



Figure 10.10.10



Figure 10.10.11



Figure 10.10.12



Figure 10.10.13

CHAPTER VIII

THE HOG HOUSE

I. PERMANENT HOG HOUSE—SITE—ARRANGEMENT—PLAN No. 1—PLAN No. 2—DETAILS OF CONSTRUCTION—FLOOR—OVERLAY—PENS—FARROWING PEN—WINDOWS—DOORS—WALLS—ROOFS—YARD. II. MOVABLE HOG HOUSE—THE "A SHAPED"—"SHED-ROOF"—TROUGHs—CONCLUSION.

There are two general kinds of hog houses now in use—the permanent hog house, and the movable hog house. The former is built to accommodate a large number of hogs, the latter for the individual hog. Each has its advantages: the permanent house, in its saving of labor and time, and the movable house in its greater possibilities of sanitation and isolation. In general, it can be said that for the farmer who makes a business of raising hogs the permanent house is best, while for the farmer who is merely raising a few hogs on the side and does not wish to spend much money on them, the movable house is the one to use.

THE PERMANENT HOG HOUSE

Site—Since the permanent house is to become a part of the farmstead, the first thing to be considered is location. A permanent hog house should always have a slope away from it in all directions to prevent the formation of wallows, which are not only unsightly, but are excellent distributors of disease among the hogs.

Arrangement—The next consideration, of course, is convenience. The blue print of the hog house shows the plan of this building at the Wisconsin Experiment Station.

The dimensions of the house can be read on the plan. A careful study of one pen gives the key to the whole interior arrangement. Note the swinging doors that lead from the feed alley into each pen. In the rear of each pen a plank platform about 4 x 4 feet is built with a railing of gas pipe on the sides nearest the wall. The cross section of the pen as shown in the blue print, shows how the gas pipes are placed. Note that they arch above the floor about six inches and that there is enough room between them and the side of the pen for a suckling pig. This arrangement is to prevent the sow crowding her pigs up against the wall and lying on them. There is a trough in the front of each pen, which is shown in the sketch showing detail of front of pen. The swing panel, which swings out over each trough, keeps the pigs out until you have finished pouring in the swill. Note also, in the sketch showing the detail of the window, that each window is on a hinge with a chain fastened to the top so that it may be opened. This is a very desirable

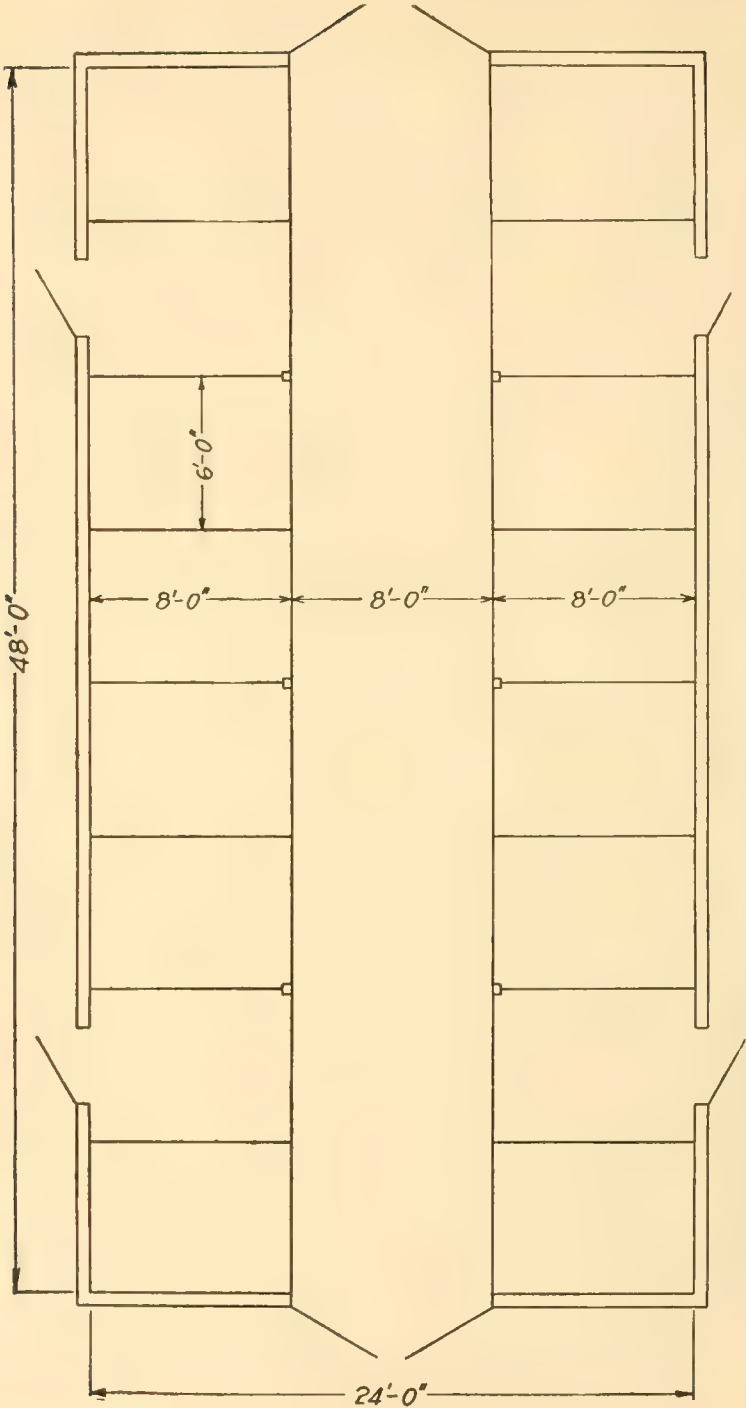

Fig. 1.—Ground Plan for Combination Hog House.

Courtesy of the Wisconsin Experiment Station

feature, especially during warm weather, as it makes possible the free circulation of air. The windows face the south. The lower tier permits the sun to shine in the pens on the south side and the upper tier into the pens on the north side. This is of special advantage in winter, when the hogs delight in sunshine.

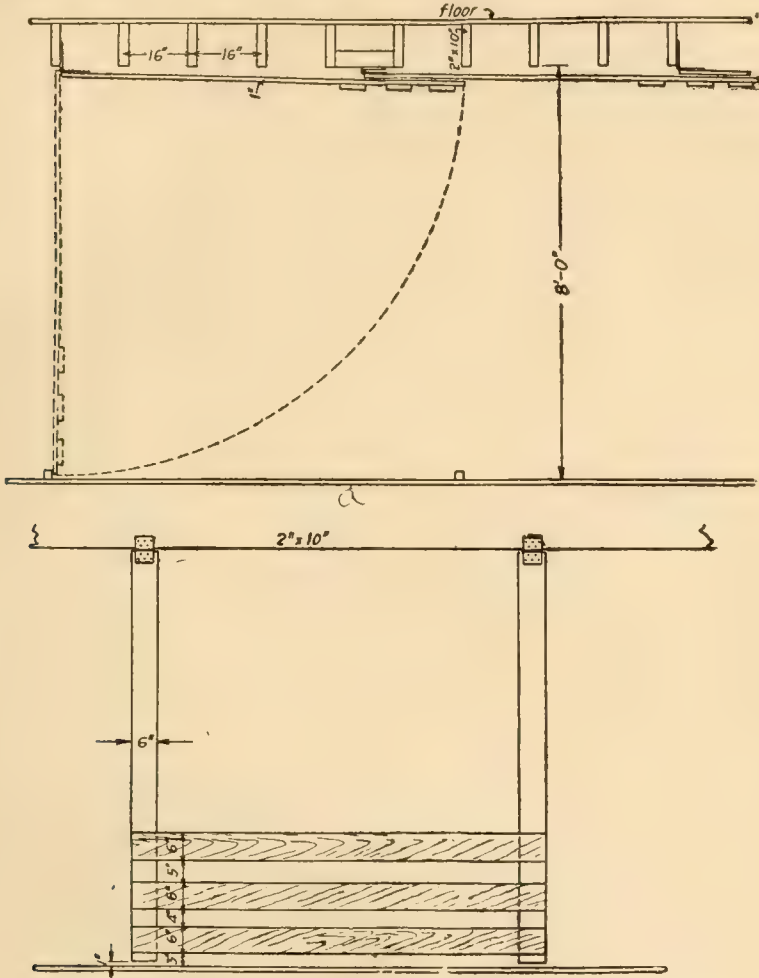

Fig. 2.—Swinging Partitions as Used in Combination Hog House.

Courtesy of the Wisconsin Experiment Station

Each pen has a door leading to the outside. This makes a hog yard, pasture, or runway on each side of the hog barn necessary. Notice that the concrete floors on each side of the barn slope toward the open drains in the alley. (See section view.) The advantage of this is that the bed side of the pen is always dry, for the sewage runs to the open drains in the feed alley, instead of running out through the door by which the hogs enter and forming a wallow there. However, it will be necessary to flush out

the drains with water every few days, because the sewage has a tendency to collect in the drains. The center of the alley is raised above the drains so that it will remain dry.

If a smaller house is desired, this plan can be cut in half, crossways or lengthways, and still make a good hog house. The former division would be advisable because it would save lumber and make a more convenient hog barn. The alley partition of any pen can be removed and the pen converted into a feed bin, butchering room, dipping room, weighing room, etc. One common objection to the large hog house is that the building is expensive and in use only a part of the year.

Fig. 1 shows a hog house which can be entirely, or in part, converted into a sheep barn or an implement shed in summer, and which is very inexpensive. The partitions between pens are hung with hinges on the joists

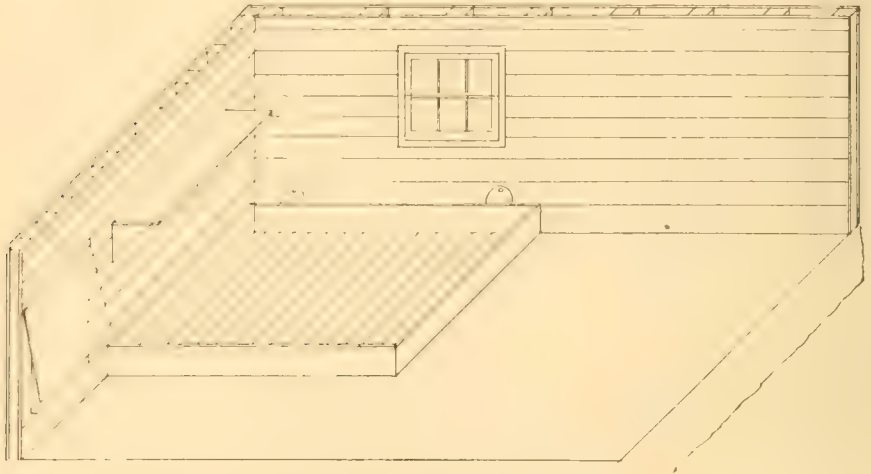

Fig. 3.—Overlay for Concrete Floor.

above, assuming that it is a two story building. When the barn is not used for hogs, these can be swung up and fastened to the ceiling as shown in Fig. 2. The partitions forming the alley can be unhinged and removed. The hog barn is then ready to serve as a store-room or put to whatever purpose the farmer chooses. The doors and central alley are 8 feet wide so as to admit the manure wagon. This central alley also serves as a feed alley. Movable feed troughs are placed in each pen.

The Floor—Earth floors in a hog house are extremely insanitary, for the hogs root them up and turn them into mudholes. They should never be used in a hog house. Wooden floors are not durable, and they are expensive. The only floor to be used is the cement floor, which is sanitary and easily cleaned. In laying the cement floor, it is always necessary to have a drop of at least one inch in seven feet. Where overlays are used, the cement floor must always slope away from them.

The Overlay—The hog soon becomes crippled or rheumatic when compelled to lie on a cement floor, no matter how good the bedding may be, and to overcome this serious disadvantage the overlay, shown in Fig. 3 is used.

This consists of a panel of boards 6 x 6 feet which fits in one corner of the pen and is hinged to the wall as shown, to be lifted out of the way in cleaning. The overlay should always rest on 2-inch sills so as to have an air space under it, and the floor should slope away from it to give drainage. Hogs always prefer the overlay to the cement floor, and will use it continually, rarely soiling it with urine or droppings.

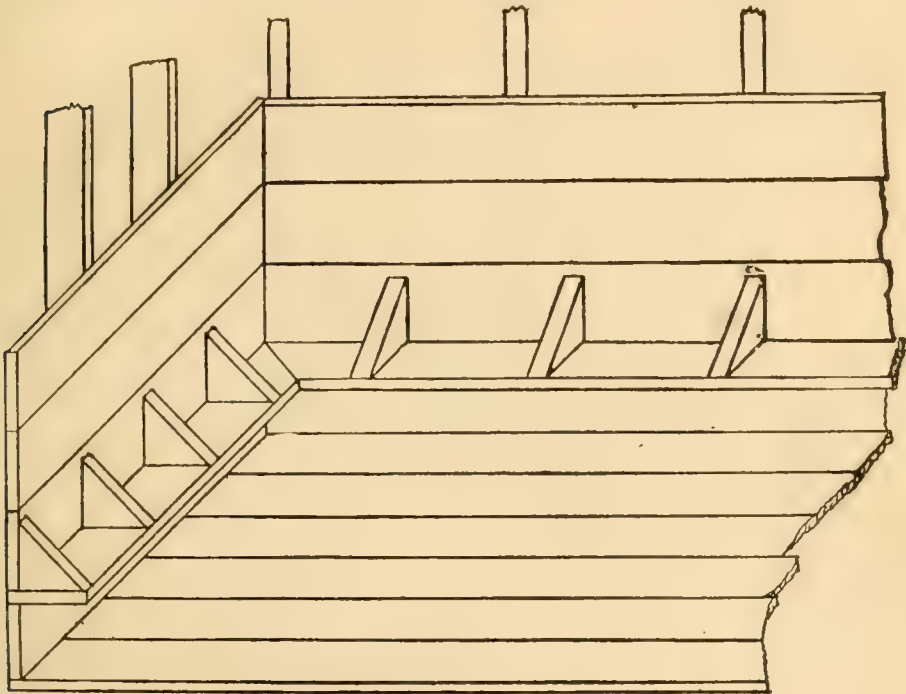

Fig. 4.—A Corner of the Farrowing Pen.

Courtesy of the Wisconsin Experiment Station

Pens—Probably the best size for the pig pen is 6 x 8 feet, varying, of course, with the size of the building. The pen partitions should not be higher than 3 feet 6 inches, as they would then interfere with air circulation. Trouble will be experienced from the hogs chewing at the partition timbers. This can be largely overcome by nailing the slats vertically. All sills and the bottoms of all partitions should be raised 3 inches from the floor, or they will soon rot out. Cement bases can be left in the floor for the sills if desired, or they can be made after the sills are up, by filling under them with concrete. The former is preferable, because when the concrete in the floor has once set, the bases will not knit with the floor and they may break loose.

The Farrowing Pen—A hog must never be allowed to farrow on a cement floor. She pushes all the straw into a pile and lies on it, and the young pigs crawl off the straw upon the cold cement floor, where they fall down, cannot get on their feet again, and soon die from cold and exhaustion. For this reason special pens should be built for farrowing, with a wooden floor. As the pen is not in continuous use, the wooden floor can readily be kept clean. Another reason for the special farrowing pen is the fact that in the ordinary pen the sow can lie up against the wall, and crush some of her litter against it. The fender shown in Fig. 4 is a simple way of keeping the hog away from the wall, and should be in every farrowing pen.

Windows—There should be at least one 3 x 3-foot window for each pen. Hogs like to bask in the sunshine, and should have as much of it in

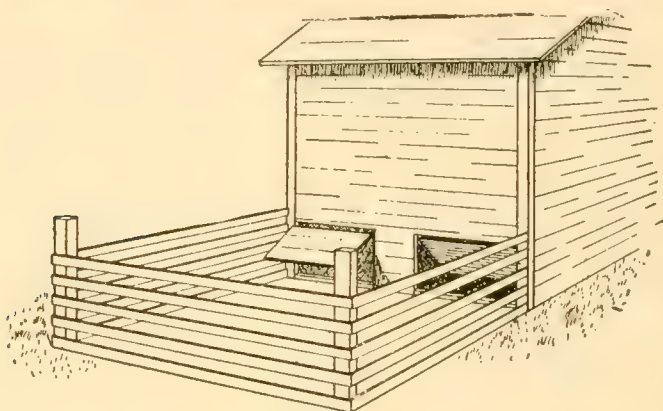

SELF-CLOSING PEN DOORS

Fig. 5

Courtesy of the North Dakota Experiment Station

winter as can be admitted. In warm climates the whole front wall of the pen is left off, and wire netting substituted for it. This, of course, is impossible in the North, but plenty of sunlight should be given them.

Doors—The door of a pig pen should always be in one corner as shown in Fig. 3, both to prevent draughts and give room for the overlay. The best doors are of the swinging type as shown in Fig. 5. These doors are always shut, and require no attention. This type of door has one serious disadvantage in that it may swing down and injure, if not kill a small pig, which might be in the way.

Walls—It should be remembered that the walls must be air-tight, for the King ventilating system will not work well unless they are.

Lofts—In cold climates there should always be a loft above the hog house, filled with hay or bedding. This absorbs the disagreeable



Figure 1. Structure of the roof truss.



Figure 2. Structure of the roof truss.

odors and prevents the moisture from collecting on the walls and ceiling in zero weather. Food, however, should never be stored in the loft above a hog house, because it will be continually exposed to foul and ill-smelling air and the hogs will not relish it.

The Roof—This need not have much pitch. It may be covered with any prepared roofing material, and is usually of the lean-to form.

The Yard—All hog houses should have yards, preferably on the south or sunny side. They should have good surface drainage. Since corn

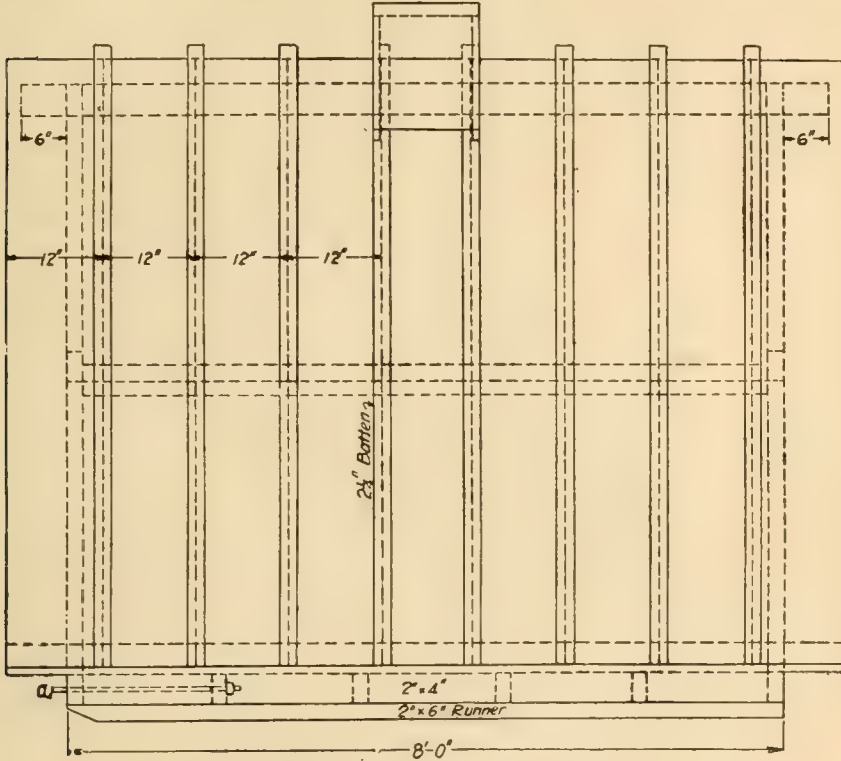

Fig. 12.—Side Elevation of A-Shaped Hog House. Eyebolt at A.

Courtesy of the Wisconsin Experiment Station

should be fed to hogs outside in the summertime, there should be a concrete feeding floor in the yard. Feeding on the ground is not so sanitary and wastes feed.

THE MOVABLE HOG HOUSE

The two greatest advantages of movable hog houses are that they can be regulated to the size of the herd, and can be moved to new pastures each season and during a season, thus avoiding the insanitary permanent building and permitting isolation as a check to contagion. Indeed, if the movable hog house system could be introduced on every farm, it would greatly aid in stamping out the dreaded cholera.

There are two popular types of movable houses, the "A" shaped and the "Shed-roof" type.

The "A" Shaped Movable House — Fig. 10 in the blue print shows the end elevation of the "A" shaped house. The door slides in grooves in the battens, and the glass is necessary to give some light to the hog. Fig. 11 shows the rear end elevation. The door, fastened with cleats, is necessary at farrowing time. The upper door is used in ventilation.

Fig. 12 shows the method of laying the side boards vertically and battening them down. It also shows the runner with the method of securing the eye bolt to which the drag-ropes are fastened.

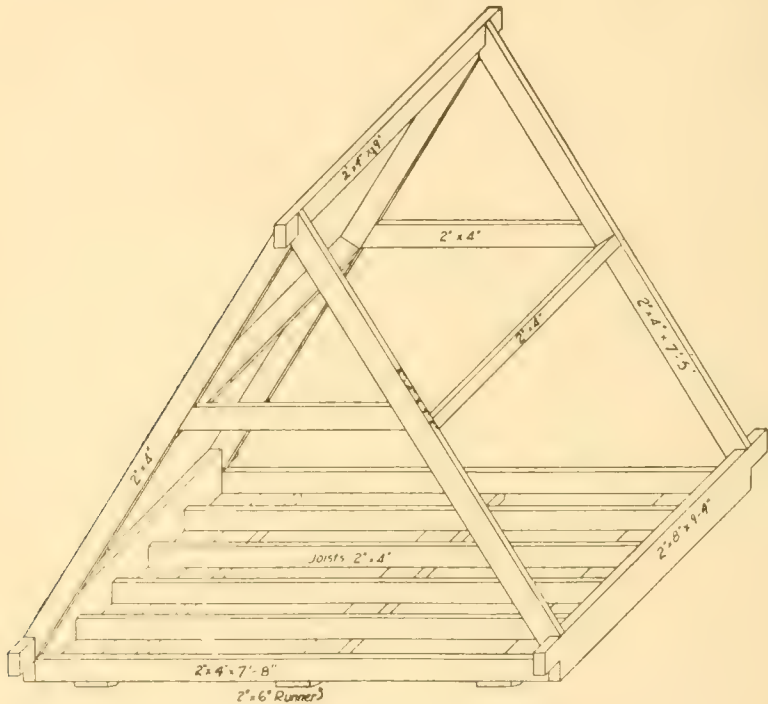

Fig. 13.—Frame of A-Shaped Hog House.

Courtesy of the Wisconsin Experiment Station

Fig. 14 shows how the ventilator, a cap over a hole in the ridge of the roof, is fastened to the two central cleats, leaving an air space through which the warm air passes. This provides sufficient ventilation for two or three hogs, when all doors are closed.

There are three good features about an "A" shaped house: The sloping roof does not heat up so much as a flatter roof during the hot weather; the interior roof space is less, making it cooler in summer and warmer in winter than the shed-roof type; it can be very well ventilated; and the sloping sides serve as fenders in farrowing time.

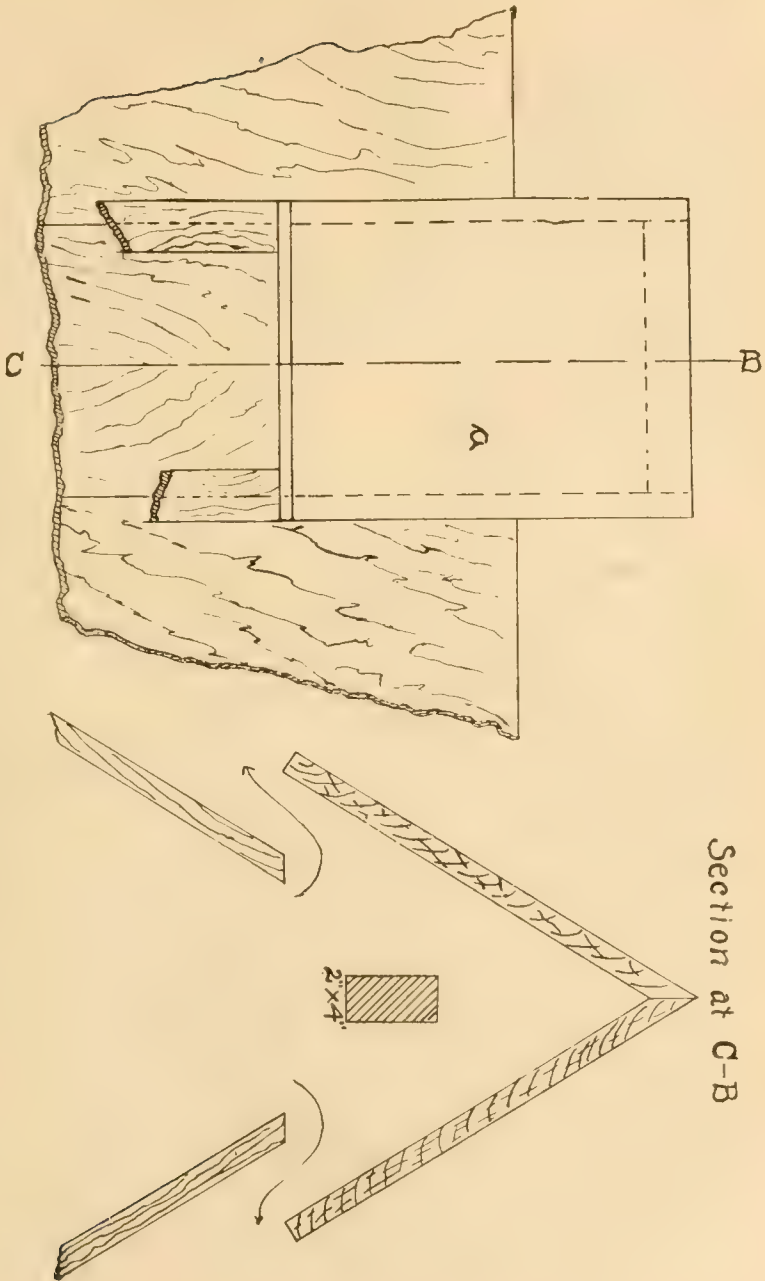

Fig. 14.—Ventilator, Side Elevation and Cross Section.
Courtesy of the Wisconsin Experiment Station

The "Shed-Roof" Movable House — Another good type of movable house is the "shed-roof." The front elevation is shown in Fig. 15. Note that the ventilation is secured by a long trap door near the roof of the house. This has a clamp lock arrangement so that it can be opened any distance and clamped tight, securing the proper ventilation under various conditions. A similar ventilation door is placed in the rear wall of the house. Figs. 16 and 17 show the side elevation and the skeleton or frame.

The advantage of the shed-roof type lies in its greater roominess and superior ventilation. It is, however, colder in winter, and, because of its

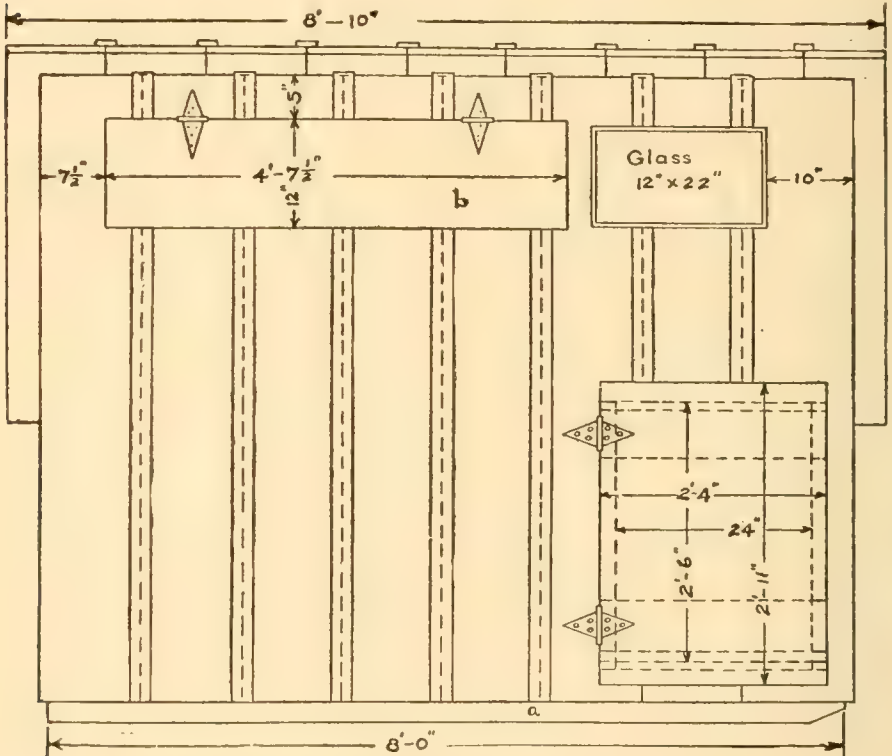

Fig. 15.—Front Elevation of Shed-Roof Hog House.

Courtesy of the Wisconsin Experiment Station

large roof space, warmer in summer than the "A" type house.

It is believed that the farmer can readily construct these simple houses from the plans given. They are by no means the only types of hog houses built, but they represent the best form we know of, and are inexpensive and convenient. One objection to the movable house has been that it is a nuisance to run all over the farm feeding hogs in winter. This can be avoided by dragging the houses in and setting them up in colonies as shown in Fig. 18. A pen and cement floor can be provided then as shown and the arrangement is very convenient for winter feeding.

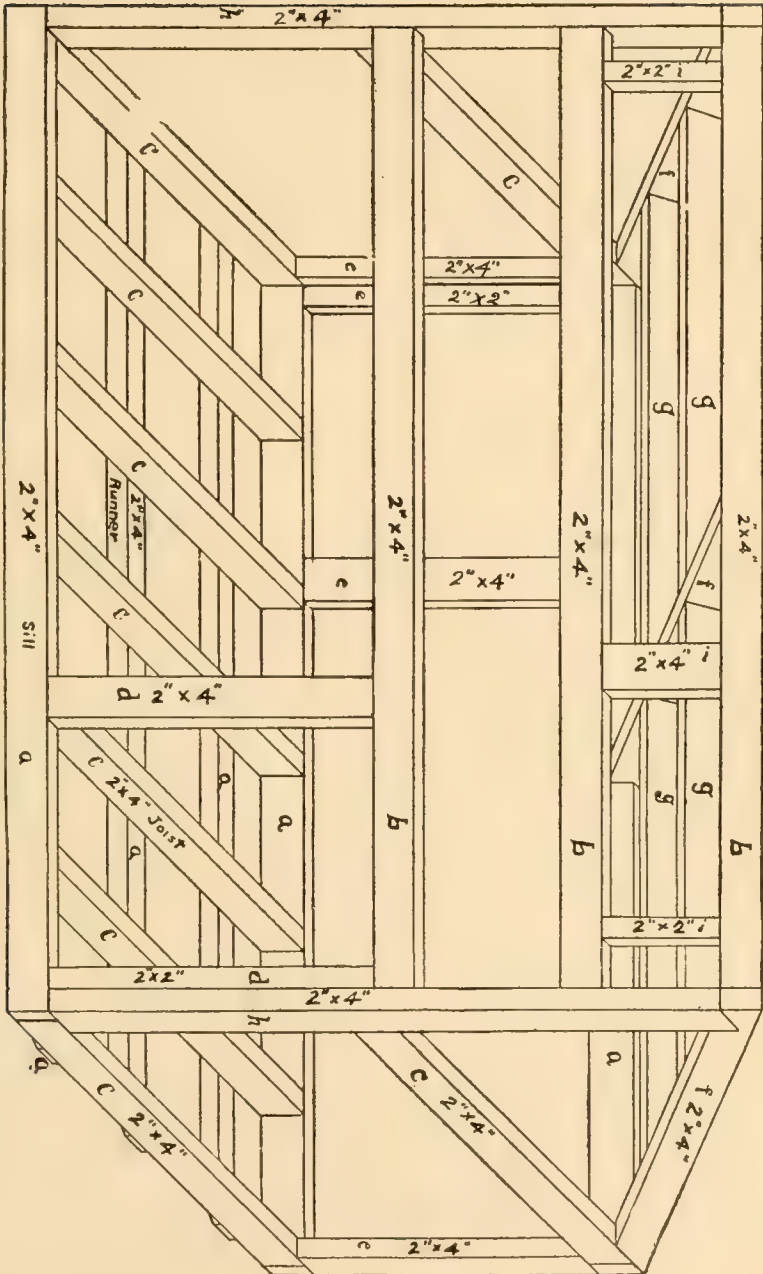

FIG. 17.—Frame of Shed-Roof Hog House.

Courtesy of the Wisconsin Experiment Station

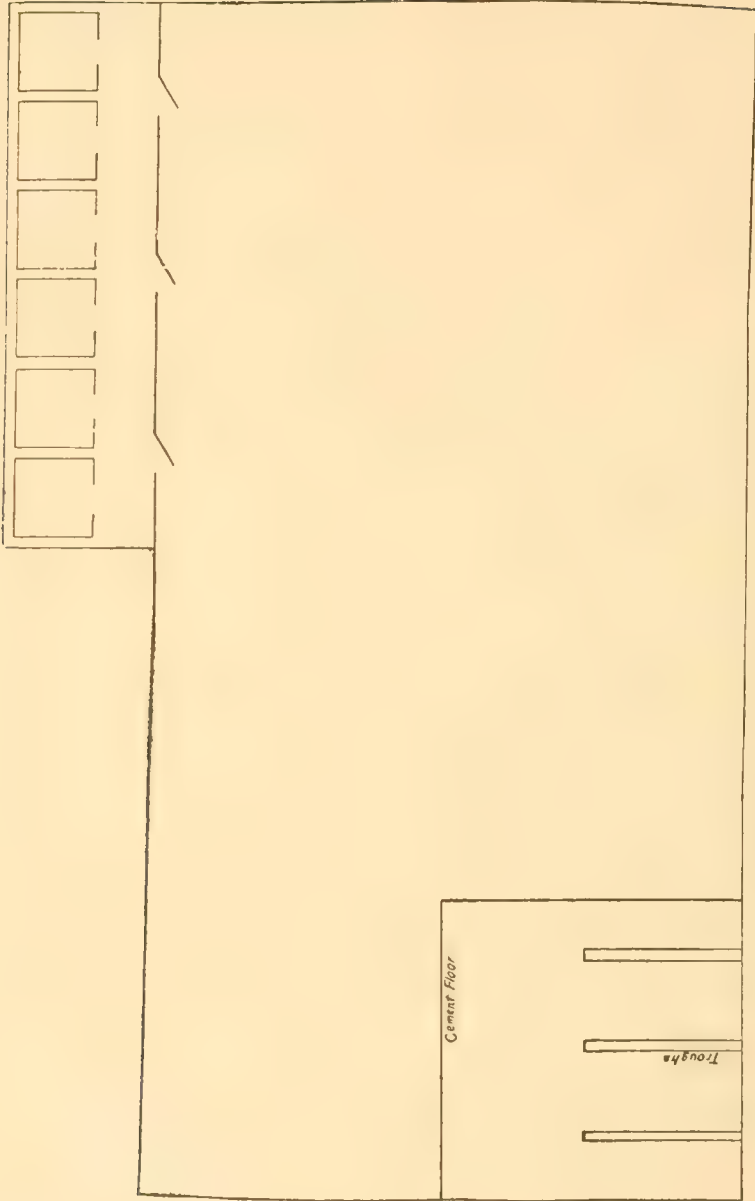

Fig. 18.—Yard Plan for Movable Hog House and Feeding Floor.
Courtesy of the Wisconsin Experiment Station

Troughs — For permanent buildings the V-trough is best, because it can be cleaned out easily by the hogs and there is not space under it where dirt may accumulate. If used for outdoor feeding it is in danger of being tipped over by the hogs unless a long enough cross-piece ($2\frac{1}{2}$ to 3 feet long) is nailed to the end of it. The square trough which the pigs can shove around but cannot tip over is in general used for outdoor feeding.

Conclusion — Hogs suffer much in hot weather. They seek relief in ponds and streams. They are not particular whether they lie in a clear stream or a mudhole if they can only keep cool. How any one could infer

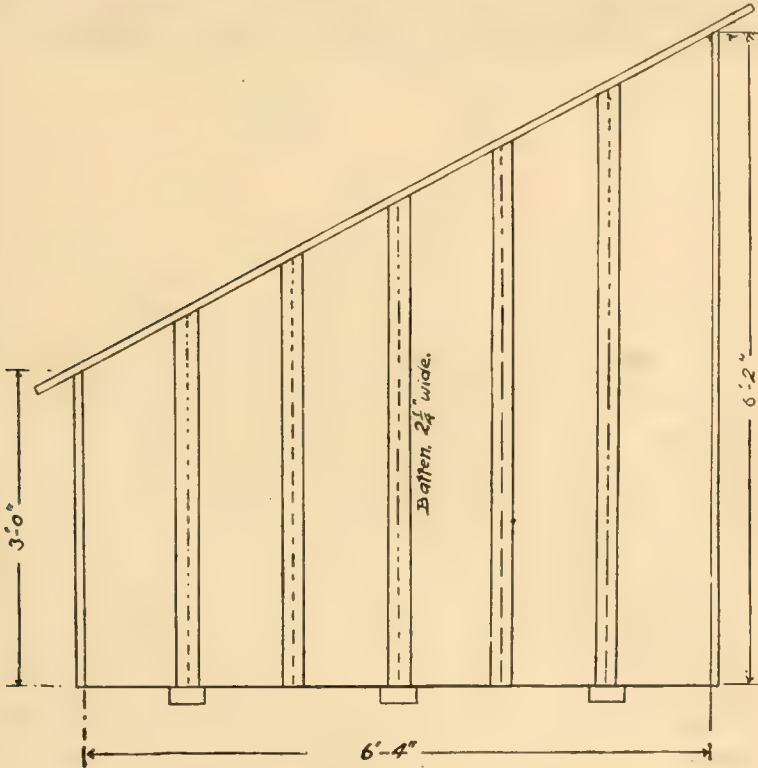

Fig. 16.—End Elevation of Shed-Roof Hog House.

Courtesy of the Wisconsin Experiment Station

from this that hogs preferred mud and slimy water is beyond comprehension. But this has become one of the farm traditions, and the hog has been compelled to lie in disease-spreading mudholes from time immemorial. Three-fourths of the epidemics among hogs can be traced to the insanitary wallow. It is time we put aside the middle ages in our farming methods and pave the hog pen. If we gave the hog sanitary quarters, we would probably have very little trouble with hog cholera. Give the hog a clean, cool place to stay on a hot summer's day and he will not need any wallow.



Long Poultry House at Wisconsin College of Agriculture.

Courtesy of the Wisconsin Experiment Station

CHAPTER IX

THE POULTRY HOUSE

THE SITE. I. PERMANENT POULTRY HOUSE—PLAN—FLOORS—WALLS—ROOF—LIGHTING—VENTILATION—LOFTS—PARTITIONS—ROOSTS—DROPPING BOARDS—NESTS—FEEDING DEVICES—DRINKING DEVICES—DUST-BATH. II. LONG HOUSE—YARDS. III. MOVABLE POULTRY HOUSE—SMALL FLOCK LAYING HOUSE—BROODER HOUSE—INCUBATORS.

Perhaps the most universally neglected building on the farm is the poultry house. Usually it is an old building originally made for some other purpose, and clumsily transformed. Often it is merely a shed against the barn wall. From the standpoint of the hen the appearance, doubtless, makes no difference. But the poultry house must be a comfortable place for her to live in, or she will not thrive or produce profitably.

The Site—Poultry houses should always be located on high and well drained land. If the land is not naturally drained, it must be tiled, for a muddy poultry yard is very bad for the fowls. A south slope should be chosen when possible. The house should always face the south to give it the necessary sunlight. It should be protected from all violent winds, even if a windbreak must be built to shelter it. In no case should the poultry house be near enough to the other buildings for the chickens to infest them. Chickens should never be allowed to roost in the barn, cow stable or implement shed. They should never be encouraged to hang around the house by feeding them scraps from the back door. The poultry house and yards are the proper places for chickens, and they should never be permitted to become a nuisance about the place.



Fig. 1. — Front elevation of the building. —
 Fig. 2. — Side elevation of the building. —



Fig. 3. — Cross-section of the building. —

There are two general types of poultry houses, both of which will be discussed at some length; the permanent, and the movable types. The former is usually employed for laying hens, while the latter is used for young fowls.

THE PERMANENT POULTRY HOUSE

Fig. 1 in the blue print shows a good type of permanent house. Fig. 2 shows the interior arrangement in cross section. In building a poultry house of any kind, three things must be borne in mind; it must be well ventilated, it must be warm in winter, and it must be conveniently arranged. Let us study the model house in Fig. 1 and see how these things are accomplished.

The Floor — The best floor for a poultry house is made of concrete. Fig. 3 shows such a floor. The sills are first built of concrete. Then cinders are packed down within the floor space, and the floor laid level with the top of the sills. The wooden sills fit on the concrete foundation and are fastened to it by bolts. Such a floor is water-proof and rats and other rodents can never gnaw into the house. The floor should be covered with a four-inch layer of sand when in use.

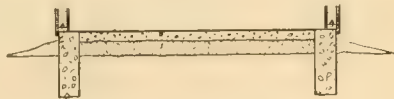

Fig. 3.—A Well Constructed Floor for a Poultry House is shown above.

The Walls — Cement walls must never be used in a poultry house, as they become damp and frost-covered in winter. Wooden walls, made either of matched siding or of rough boards and roofing paper battened down are most satisfactory. The wall must always be tight, however, to exclude draughts.

The Roof — Figure 4 shows the three best types of roofs for poultry house.

The most common of all is the shed roof, shown at "a." This is simple to construct, and does not absorb heat. It cannot be used on houses more than 14 feet wide, however, because it sags under its own weight, and the water does not run off.

The gable roof shown at "b" absorbs more heat from the sun than the shed roof, and has the disadvantage of shedding water down the front of the house, turning the yard into a puddle. It is much stronger than the shed roof.

The best roof is the combination roof, drawn in solid lines. This, as can be seen, is a combination of the shed and gable roofs, and combines the best features of each. It must always be high enough to permit one to work under it without stooping, and should allow the sunlight to cover the whole space as shown.

The best materials for roofing are hemlock shiplap, covered with a reliable patent roofing.

Lighting—The glass frame house has fallen into disuse among poultrymen. It heats up too much during the day and cools off too fast at night, causing too wide a variation in temperature. There need not be more than one square foot of glass to every 16 x 20 square feet of floor space. A good sized window is 3 x 3 feet, with panes 9 x 12 inches. It is more desirable to place the windows high than low. The proper height to place the windows in north temperate climates is as follows:

Height, Top of Window.	Width of Floor.
6 feet.....	14 feet
7 feet.....	16 feet
7 feet 6 inches.....	20 feet

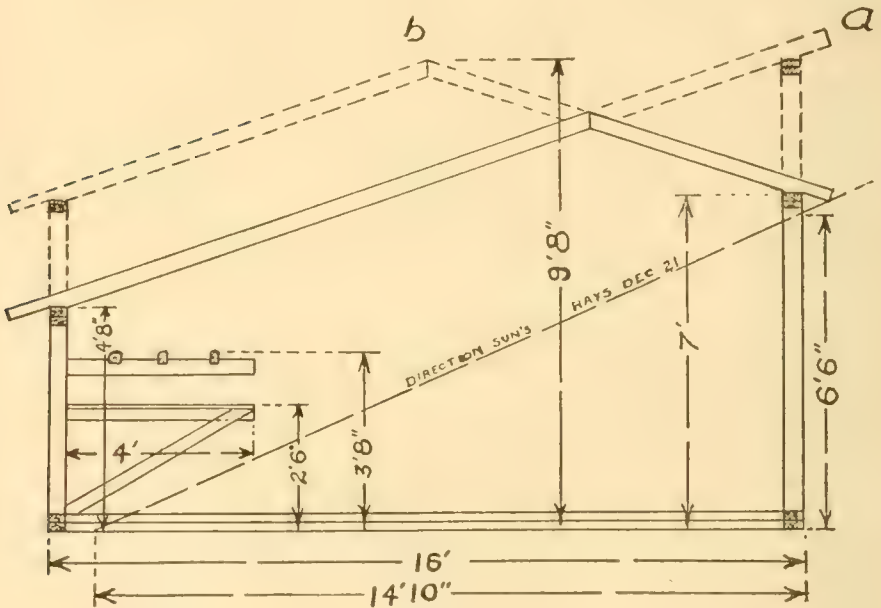

Fig. 4.—Types of Roofs.

Courtesy of the Wisconsin Experiment Station.

Ventilation— After experimenting with patent ventilators, muslin covered windows and the like, poultrymen are gradually coming back to the open window as the best ventilation for the poultry house. It is useless to equip a poultry house with any kind of a patent ventilator. It never gives satisfaction on low buildings. The muslin cloth is being successfully used in the Middle North. It keeps out the winds and draughts, and at the same time allows the air to circulate through it. But when it becomes damp or dirty, it is worse than useless as a ventilator. In zero weather when the moisture collects on the walls and ceiling, the muslin ventilating system ceases to work, and the fowls

are shut up in a damp room without a breath of fresh air. Poultry can stand a great deal of cold when their quarters are dry. But this combination of dampness, poor ventilation, and cold is fatal to them. On the whole, it can be said that the open window is the best way to secure ventilation. If the ventilating windows are opened so that the air will circulate over the birds on the floor, excellent results can be obtained. Where muslin is used, it must be aired out every day, or it will not work. Where the open window method is used, care must be taken that all the openings are on the same side of the building, and that no draughts reach the roosts. For temperate climates the open window is preferable. For very cold climates it is imperative.

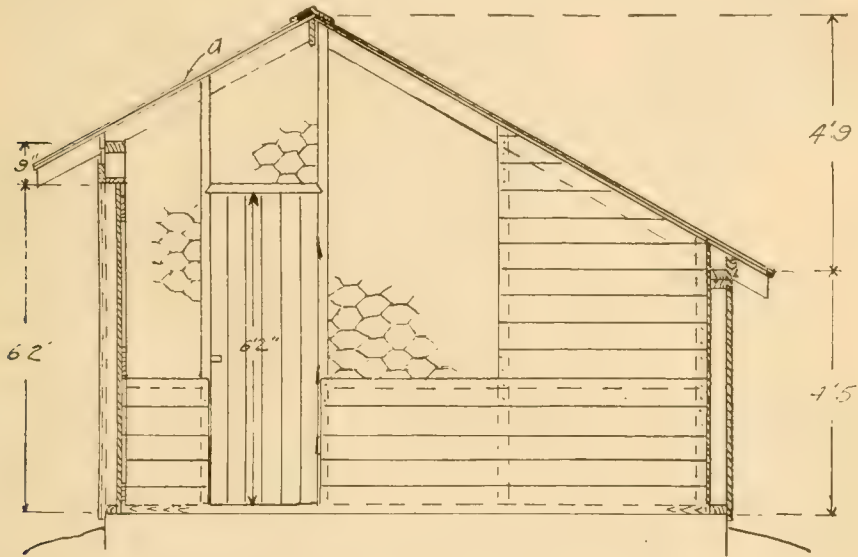

Fig. 5.—Proper Way to Make a Partition in a Poultry House.

Courtesy of the Wisconsin Experiment Station

Lofts—In cold climates every poultry house should be provided with a straw loft three feet thick. This absorbs the moisture which in zero weather would otherwise collect on the ceiling and drip down into the bedding. Each end of the loft should have perforations so that the air can circulate through the straw and dry it.

Partitions—In many poultry houses, particularly in the long-house types, it is necessary to divide the building into pens. Fig. 5 shows a partition properly constructed. The solid partition at the back protects the fowls from draught while on the roosts, and the solid partition at the bottom prevents fighting through the wire netting. The wire netting is necessary to secure proper air circulation.

The Roost—The roost of a poultry house should be in the warmest part of the building, and protected from draughts. The perches should

all be at the same height; for if they are not, the fowls will fight over the highest perch and some may be injured in falling off. As a general rule small hens should have 6 inches of perch space and larger ones 8 inches. The birds crowd together in winter for warmth, but there should be room for them to spread out in summer.

The height from the floor depends upon the breed, ranging from 2 feet for heavy breeds to 4 feet for light ones. Perches should be 12 inches apart and not closer than 15 inches to the walls and ceiling.

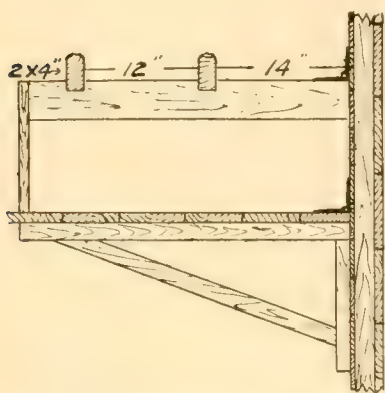

Fig. 6.—Hinged Perches and Dropping Board.

Fig. 6 shows a good method of hinging the roost so that it and the dropping board can be swung up out of the way when not in use. Where the roost cannot be arranged this way, the perches should be removable so that they can be easily taken out and cleaned.

Dropping Boards—Dropping boards should always be placed beneath the roost to keep a clean feeding floor. Being near the perches, the dropping boards must be frequently cleaned, but the fertilizer saved more than pays for the extra labor, and

frequent cleaning means healthy fowls. The hinged dropping boards shown in Fig. 6 must be cleaned each morning before being swung up with the roost. This insures a clean poultry house and does away with the bad habit of laying under the dropping board instead of in the nests. Where the boards are not hinged, they must be so arranged that they can be cleaned with the least labor, and be removed when necessary.

Nests—Nests must be convenient. Portable nests are easy to clean and handle. Darkened nests give the hen a feeling of security and lessen egg eating. Fig. 7 shows a few convenient forms of nests. B and C are box nests which are fastened to the wall with two 6d. nails so that they can be easily taken out and cleaned, or burned when infested with mites. D is a nest very commonly used. It is fastened underneath the dropping board, where it is darkened and out of the way. The hen enters from the rear and the eggs are taken out through the front of the box, making it very convenient for egg gathering. Where the folding roost and dropping board are desired, these nests cannot be used. A shows the most common nest of all, the tier nest. These are built up against the cross partition as shown in Fig. 2, and are very convenient. Three tiers are usually sufficient, and the nests should always be portable.

Often it is convenient to keep a record of each hen. Professional

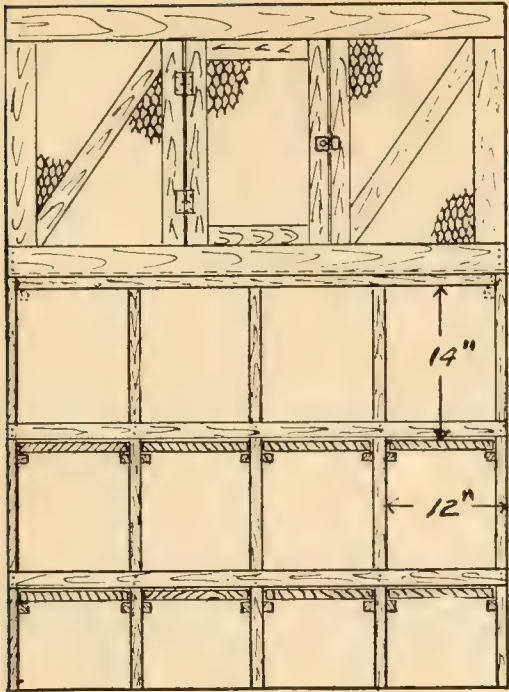

A

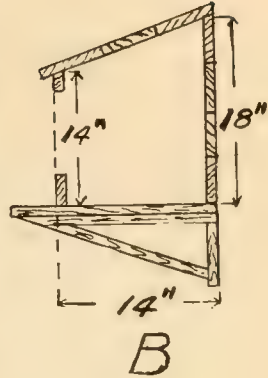

B

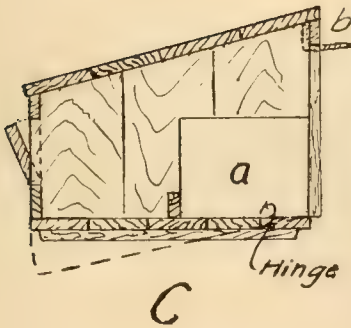

C

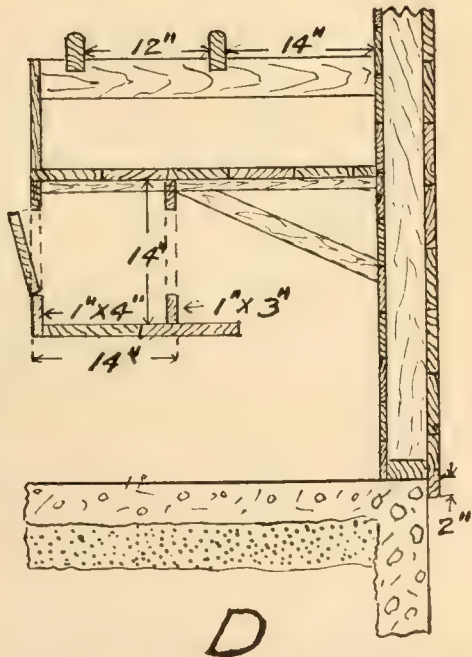

D

Fig. 7.—Different Types of Nests. A is a Tier of Nests with Broody Coop on Top. B and C Are Types of Wall Nests. D is a Nest Under the Dropping Board.
 Courtesy of the Wisconsin Experiment Station

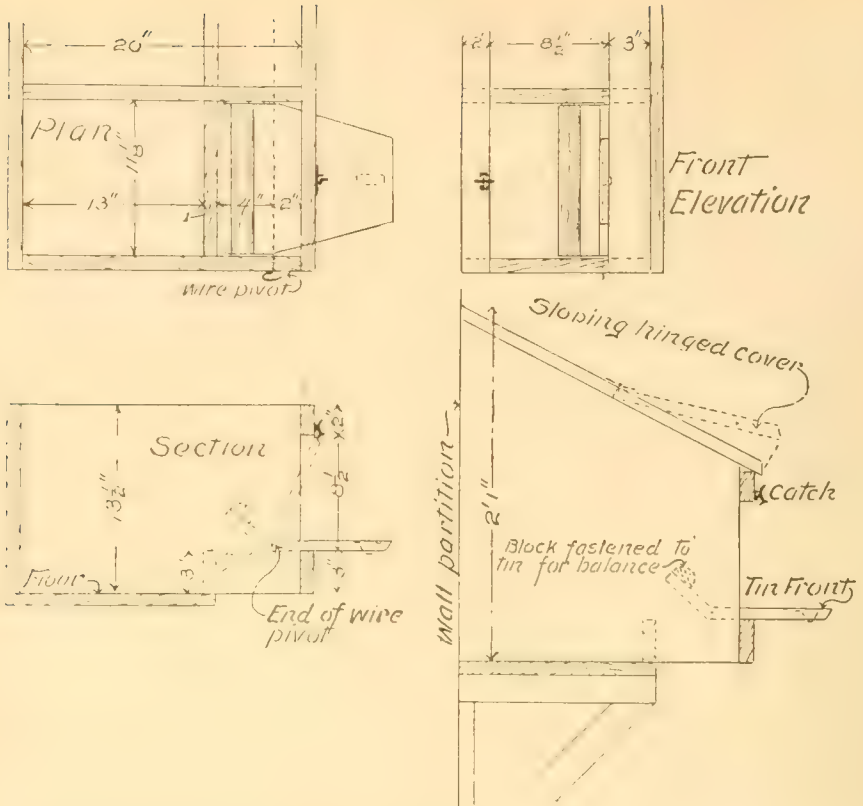

Fig. 8.—Working Plans of the Improved New York State Trap-Nest.
 Courtesy of the New York Experiment Station, Cornell.



Fig. 9.—Working Plans of a Double Outdoor Hopper.
 Courtesy of the New York Experiment Station, Cornell.

poultrymen are coming to take records of hens as a matter of course, and it would pay the farmer to know how many eggs each hen lays. To do this the trap nest, shown in Fig. 8 was devised.

When the hen goes into the nest, the door swings up and the hasp catches it automatically, holding it in place. The hen's number is of course recorded when she is set free, and her record is thus kept. There should be five trap nests to each twenty-five hens.

Feeding Devices — Most poultrymen prefer to feed grain broadcast on the floor of the house, believing that the exercise which the fowls must get in securing it is beneficial to them. But in feeding young birds and in feeding ground grains and meat scraps and the like, the feed hopper is almost necessary. Figs. 9 and 10 show a working model of a good outdoor hopper for feeds or grit.

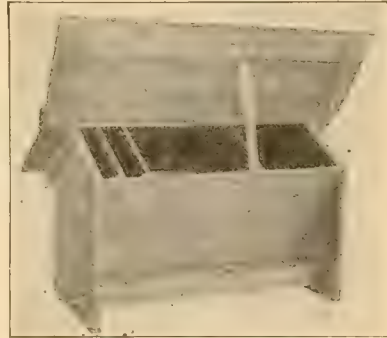

Fig. 10.—An Outdoor Hopper.
Courtesy of the New York Experiment Station

The sloping sides force the grain or grit down into the feeding trough, and the wires keep the fowls from getting into the trough or crowding each other away. The roof is hinged on one side so that open feeding can be practised. Note the compartments in the hopper. By means of these feed and shell can be fed in the same hopper without the expense of a hopper for each material.

Fig. 11 shows a handy indoor hopper that can be screwed up against the wall out of the way and used for feeding or holding grit or shell.

Sometimes the farmer has trouble with the rats gnawing their way into the food hoppers. In a poultry house that is badly infested with rodents, the best way to feed is through galvanized iron hopper, as shown in Fig. 12. These galvanized iron hoppers are rather more expensive than the wooden ones, and are much more difficult to construct. But they last longer and are more easily cleaned. It would pay the farmers in the end

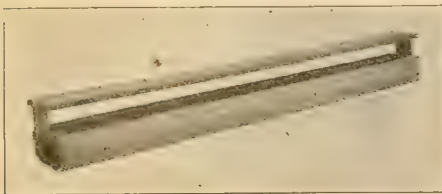

Fig. 13.—Trough for Feeding Large Chickens.
Courtesy of the New York Experiment Station, Cornell.

to invest in only galvanized iron hoppers.

Fig. 13 shows a convenient trough for feeding wet feed. The board along the top to keep the fowls from getting into the trough. It is fastened on with screws and can easily be removed for cleaning.

Watering Devices — The usual method of supplying water to the poultry house is by means of open pans. Where these are used,

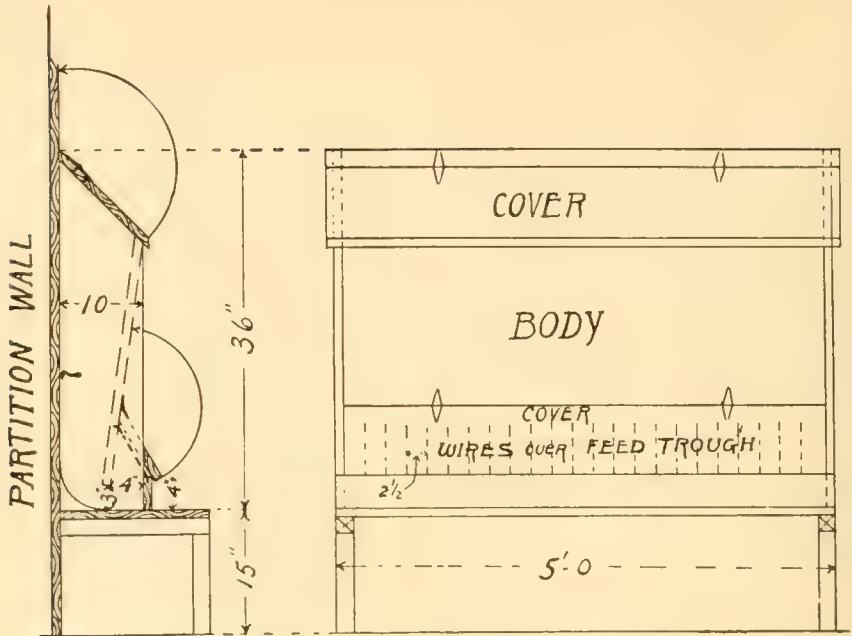

Fig. 11.—Working Plans of a Single Indoor Hooper.
 Courtesy of the New York Experiment Station, Cornell.

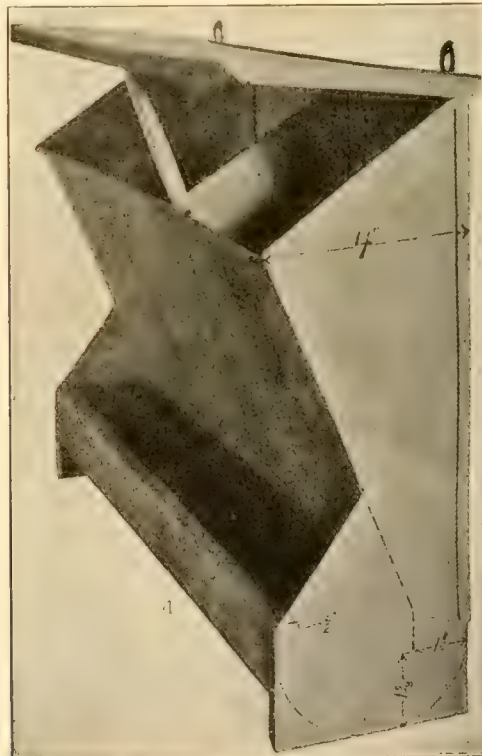

Fig. 12.—The End View of Grit Hopper, showing method of construction.
 Courtesy of the New York Experiment Station, Cornell.

they should be placed upon a raised platform 18 inches from the floor, with a runway to them. This keeps them from becoming soiled. A better method of watering is by means of the patent watering can, two of which are shown in Fig. 14. Both of these are so designed that the chickens can get plenty of water through the holes and in the narrow drinking rim, at the same time they cannot get into the pans and dirt is kept out. These pans have the advantage of not needing to be filled every day, being self-feeding.

Dust Bath—There should be a dust bath in every pen, for the problem of dealing with lice is greatly reduced by its presence. It may be just a shallow box filled with fine road dust, and should always be placed in the sunlight before the window.

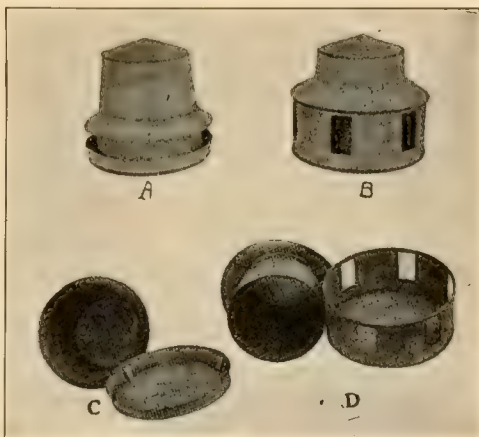

Fig. 14.—A and B are two styles of drinking pan. C and D show the interiors of the same fountains.

Courtesy of the New York Experiment Station, Cornell.

THE LONG HOUSE

Sometimes a farmer, starting with a small flock, finds poultry so profitable that he makes it his business. His problem then becomes one of enlarging his plant without undue expense, and the so-called long poultry house is peculiarly adapted to such a condition. The long house is shown at the head of the chapter. It is merely a series of houses like that shown in the blue print, built end to end as the flock increases. It can be extended indefinitely, and is quite inexpensive.

Yards—One of the greatest drawbacks to successful poultry raising has been the dirty yard. This not only caused dirty eggs and fowls, but was the constant source of disease germs. To avoid this condition the double yard system, which can be easily used with the long house, was introduced.

Fig. 15 shows the double yard system. The space to the south of the house is divided into individual runs for each pen, and is used in the fall and winter. The space to the north is an open field, which is used in summer. Care must be taken in laying out these yards that there is enough space to cultivate in, and that the gates are wide enough to admit the necessary machinery. When the fowls are turned into the north yard in summer, the runs to the south are cultivated and sown to buckwheat. In the spring, while the fowls are still in

the runs, the north field is sown to corn and alfalfa as shown in the diagram. The space nearest the house, being more likely to become dirty and contaminated, is sown to a cultivated crop, like corn, each year. By this method no filth is allowed to accumulate in the yards, germs are destroyed, and greens are provided for the poultry all summer.

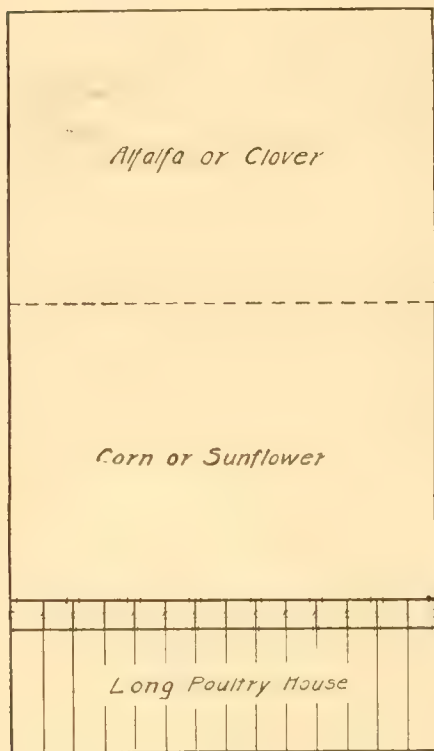

Fig. 15.—Long Poultry House with Yards in Front and Open Field Behind.

Courtesy of the Wisconsin Experiment Station

Shade—It is quite necessary that chickens be shaded in summer. The corn planted as shown in Fig. 15 answers this purpose very well. It grows sufficiently high to be useful when the fowls are turned into the yard in July, and lasts throughout the summer. If desired, permanent shade can be secured by trees. Plum trees are the best for this purpose, as they grow rapidly, are very shady, and furnish fruit to the farmer as well. It is sometimes good practice to build the poultry house adjacent to an old orchard, and fence it in, as a yard.

Turf—The poultry yard should never be covered with a grass or turf. It must be cultivated if it is to be clean and sanitary. A poultry yard should never be made in a heavy clay soil, for such a yard puddles in wet weather and keeps the fowls in a dirty condition.

Size of Yard—There should be at least forty square feet of yardage for each hen to scratch in.

The Movable Poultry House—The chief advantages which the movable house has over the permanent types are that it can be moved into the feed lot directly, and has no contaminated run or yard to spread disease. This is particularly important in the case of young chicks, which are very susceptible to contagious diseases.

Fig. 16 shows a good type of movable laying house. It can be moved to a new field each season, doing away with permanent yards and giving the fowls more freedom than they would otherwise have. The greatest disadvantage of all portable systems comes at feeding time, when the houses are scattered all over the farm. However, the increased healthfulness and vigor of the flocks should pay one for a

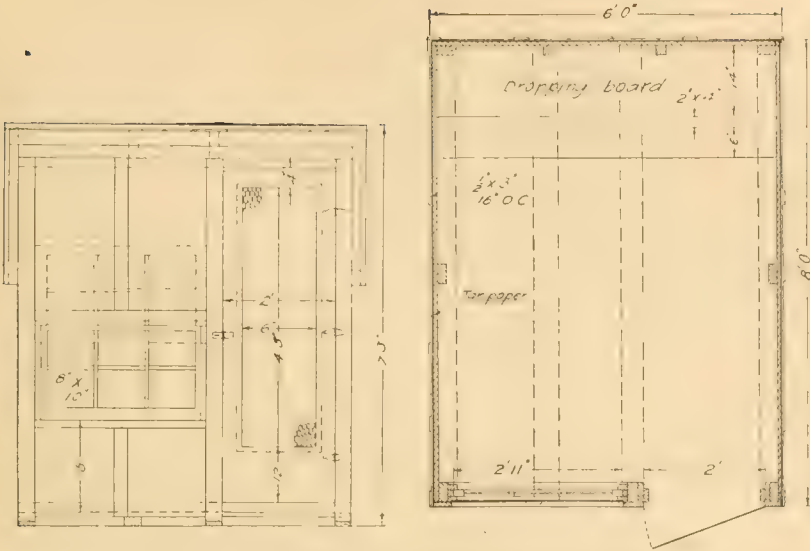

Fig. 16.—A Small Flock Movable Laying House.

Courtesy of the Wisconsin Experiment Station

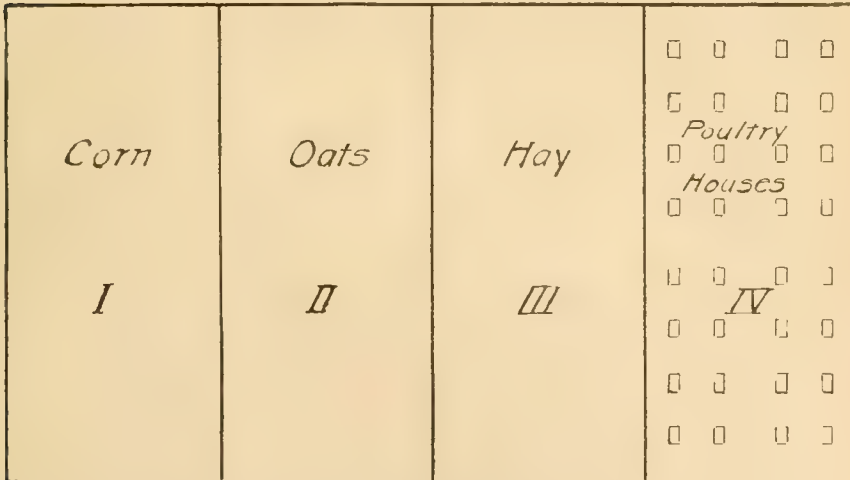

Fig. 17.—A system of rotation is possible with Portable Colony Houses. The houses can be moved each year to a different field.

Courtesy of the Wisconsin Experiment Station

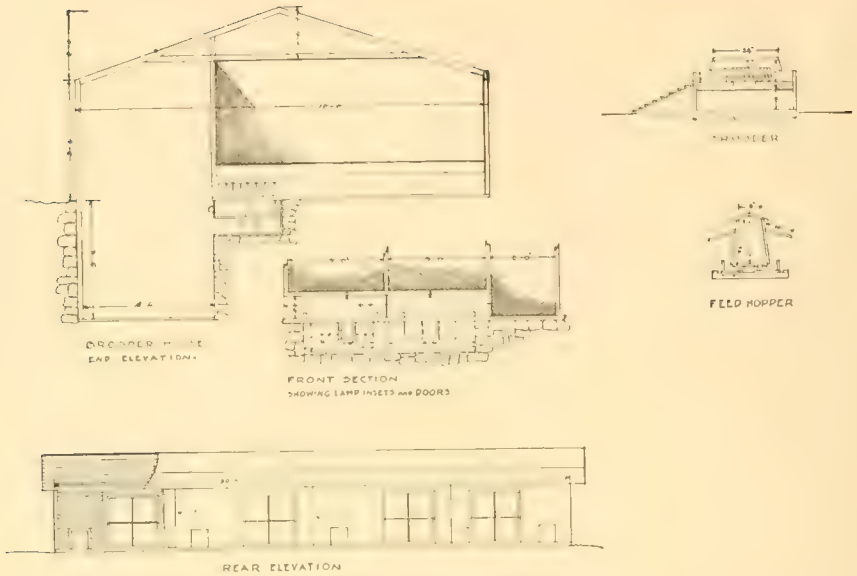

Fig. 18.—A Permanent Brooder House.

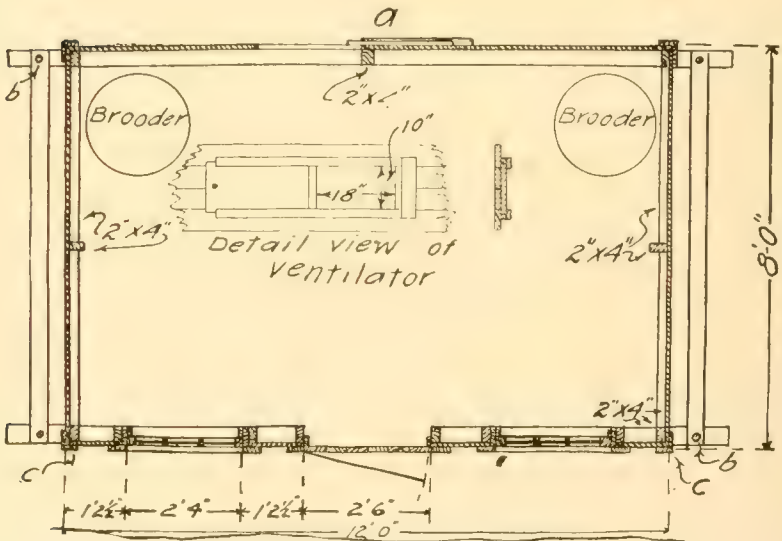

Fig. 19.—Brooding House Used at Wisconsin College of Agriculture. Note the details of ventilator. Location of ventilator is shown at A.

Courtesy of the Wisconsin Experiment Station

little extra labor. In winter all the houses may be drawn up into one field if desired, or some scheme followed like that shown in Fig. 17.

This is a system of rotation of corn, oats, hay, and poultry. The fowls are confined to one field throughout the year, in movable houses. The next year these are dragged into field III while field IV is planted to corn, and so on. The poultry furnish ample fertilizer for the fields, and yield a handsome profit besides.

The Brooder House—Young chicks should never be handicapped by being compelled to eat with older fowls. They should never be kept in yards which are in continuous use and so likely to be contaminated. The portable brooder houses are the best quarters for them. They can be started out in the brooders while very young, keeping the brooder houses near the farm house at first to protect them from wild animals, and moving into the fields as the chicks grow up. In the

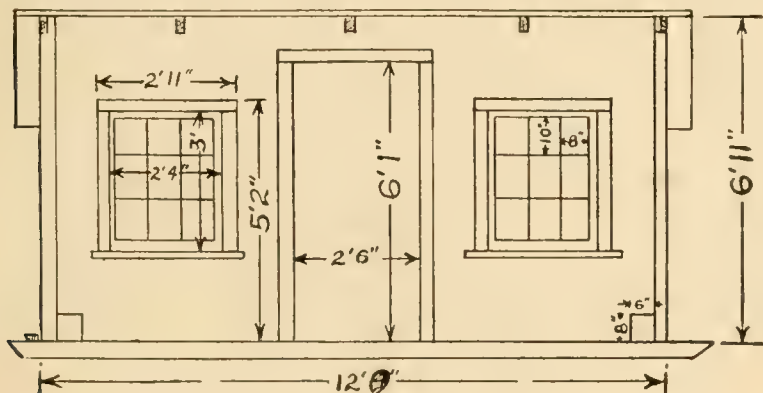

Fig. 20

Courtesy of the Wisconsin Experiment Station

fall they can be turned into the regular laying house with the other chickens.

Fig. 19 shows a good plan for a portable brooder house. Note the detail of the ventilating window in the rear. This is a very good way of securing the proper ventilation, and can be used on large houses as well as small.

Fig. 20 shows the front elevation of the same building.

After the chicks become old enough the brooders, or hovers, can be removed, and more room secured for the chicks in the building.

Fig. 21 shows how the chicks are fenced in when the brooder is in the field. Where small houses like this are used, larger houses called colony houses must be resorted to later on. It is best to start the chicks in a house large enough to last them through the first season, as the use of two houses for the same purpose is a needless expense.

Incubators—These are of two general types, the hot air and the

hot water. The heat in the latter type is transmitted to the hatching shelves by water in tubes. The hot water incubator stores more heat and is therefore less influenced by sudden failure of the source of heat. Hot air incubators are considered most durable, as those of the hot water type soon leak and, then their usefulness is over. Perhaps the most important feature of a good incubator is a reliable and accurate thermostat. Do not take one with a disk regulator, as they are poorly made and uncertain in action. A metal bar thermostat should always be used.



Fig. 21.—Outdoor Brooder and Small Run.

Courtesy of the Wisconsin Experiment Station

Conclusion — Simplicity in construction, economy of material, and efficient ventilation are the essential points to be considered in the design and construction of a poultry house. All fixtures should be convenient and movable, and utilize the least floor space. A little forethought and planning will make a convenient house and one that is satisfactory.

CHAPTER X

THE SHEEP BARN

I. ESSENTIALS. II. LOCATION. III. PLAN. IV. DETAILS OF CONSTRUCTION—PARTITIONS—DOORS—FEEDING RACKS—PENS.

Many farmers refuse to raise sheep because they have no place to keep them during the winters. This need never deprive the farmer of a profitable industry, for no farm animal can be sheltered more cheaply, or with more satisfactory results.

Essentials—Three things a good sheep barn must have: a dry floor, a shepherd's room, and a good ventilation system. Sheep are ready victims of hoof diseases which are often caused by damp, soggy floors. Moreover, sheep are dainty feeders, and will not eat from a wet and dirty floor. Everything about the pens must be dry and fresh and clean, or loss will follow. Sheep drink a great deal of water which must be fresh. For this reason it is always wise to have flowing water in the barns and pens.

The greatest loss in small herds is caused by the death of lambs in cold weather. Weak lambs can usually be saved during the coldest weather if care and artificial heat can be provided for a few hours. A man's room, provided with a stove, in which the shepherd can sleep during lambing periods, is the best way to save weak lambs, which can thus be given instant care and attention.

Ventilation should of course be designed after the King system. The number of inlets and outlets can be determined from the tables under Ventilation in Chapter III, "The Dairy Barn."

Location—A sheep barn should be situated on high dry land or else on tile-drained land. It is customary to have earth floors in the pens, and these must not be wet if the sheep are to be a success. The lambing pens should have a south exposure so as to secure the warmth and light of direct sunshine.

Fig. 1 shows a model sheep barn. The main part of the barn is 36 x 70 feet and is divided into eleven 10 x 14 foot feeding pens. The other part is 30 x 40 feet, and is divided into six 10 x 11 foot lambing pens, a man's room and a horse stall. A loft is provided for storing hay and grain, the latter of which is placed in bins above the feed room and is spouted down for mixing. A silo is also placed adjacent to the feed room, whence the feed may be distributed by a carrier.

Partitions—The partitions between the pens are made readily

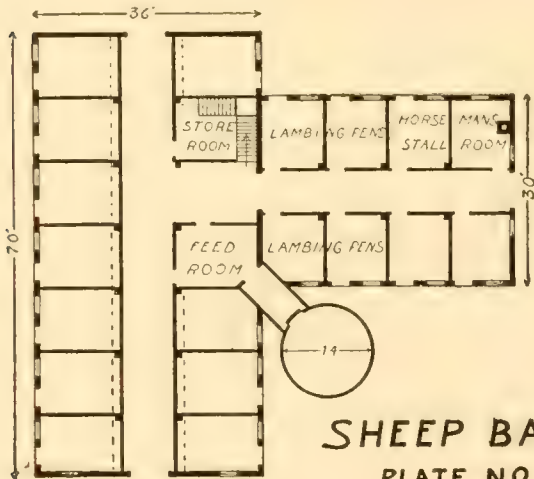

FLOOR PLAN
SCALE IN FEET

SHEEP BARN
PLATE NO. 19

Fig. 1

Courtesy of the North Dakota Experiment Station

movable and can be taken out when desired. Space should be provided for weak and disowned lambs in the sunny corners of the pens. The simplest way of providing this is by means of little gates 2 feet 6 inches high by 3 feet long. These gates are provided with hooks at both ends, and two of them hooked across a corner make a pen. When not in use they can be stored in some out of the way place.

Doors—Narrow gates or doors are a sure means of loss. Sheep will always crowd into doorways, and if these are too narrow some are sure to be suffocated or trampled to death in the crowd. This is also one of the most common causes of abortion in sheep.

Feeding Racks—Sheep feed best out of doors, and this should always be practised when the weather permits. There should be feed racks inside, however, for stormy days and when the snow is on the ground too deep for feeding. These feed racks should be placed along the center alleys where they can be easily reached. They can be any convenient form, and should be movable. Slats about one foot apart help save feed and prevent crowding. There should be plenty of rack room so that lambs can get hay as soon as they wish. The feed racks must be cleaned thoroughly and often, for sheep will not eat from dirty racks or mangers.

Pens—Sheep should never be allowed to run around the straw stack or with other farm animals. Their fleece becomes ruined and they are constantly being injured in some way or other. They should have individual pens, which should be both dry and clean.

When properly housed, sheep can be grown with profit anywhere in the northern states. A little care in feeding and housing will bring more profits from sheep than from any other farm animal.

CHAPTER XI

THE GRANARY

I. LOCATION. II. TYPES—TWO-STORY—METAL—ELEVATOR—PLAN FOR ELEVATOR—ELEVATOR—CONSTRUCTION—COST—ADVANTAGES OF ELEVATOR.

The grain farmer, as a rule, does not keep his grain very long, and provides temporary storage for it in the various buildings until it can be sold. It is a much better plan to have storage capacity so that grain may be held and the farmer take advantage of good markets.

Location—The granary should be located near the barns, so as to require the least amount of trouble in filling and emptying. If the grain is to be taken from the bins for daily use, the granary should be near the place of feeding. But if it is to be used principally as a storehouse, the position is not so important.

Types—There are three common types of granaries, the ordinary two-story, the metal, and the elevator. The two-story type is found on nearly all farms. The grain is hauled from the thresher to the granary and must be taken in and out by hand. The process is laborious, and the cost per bushel capacity ranges from ten to fifteen cents.

The metal type is factory made, and costs from eight to twelve cents per bushel capacity. The farmer must pay the freight and set up the granary. It has some advantages over the two-story type in that it can be moved from field to field and loaded direct from the thresher. It is, moreover, mouse-proof, being provided with a metal floor and roof.

The third, or elevator type, is by far the best of the three. This is provided with an elevator run by a gas engine, and the grain can be elevated and spouted into the bins or into the wagon box as desired. The power used on the elevator may also be used to run a cleaner and to grind feed.

Fig. 1 shows an excellent type of elevator granary.

This has a ground plan of 20 x 32 feet, with a height to the plate of 12 feet. It has a capacity of 3,700 bushels on the first floor, and a possible capacity of 2,000 more bushels on the second. Slight reinforcing of the floor and the installation of an extra spout are all that is necessary to develop its full capacity.

The Elevator.—A load of grain from the thresher is backed up to the point A and the hinged door drops down just low enough to permit the end of the wagon box to pass over it. The end of the wagon box is

removed, and the grain is shoveled, or dumped, if the elevator is provided with a dump or lifting jack, into the drag elevator, which carries it down into the pit. Here it is taken up by the endless bucket chain to the top of the granary and distributed to any bin on the first floor by means of the movable spout B.

When the bins are to be emptied, any slide in the bin floors at C may be opened, and the grain carried to the pit and elevated. It can then be loaded on wagons through the spout D, or run down to the first floor by B to be sacked, cleaned, or ground. The engine is directly connected with the line shaft, and from this belt run to the head of the

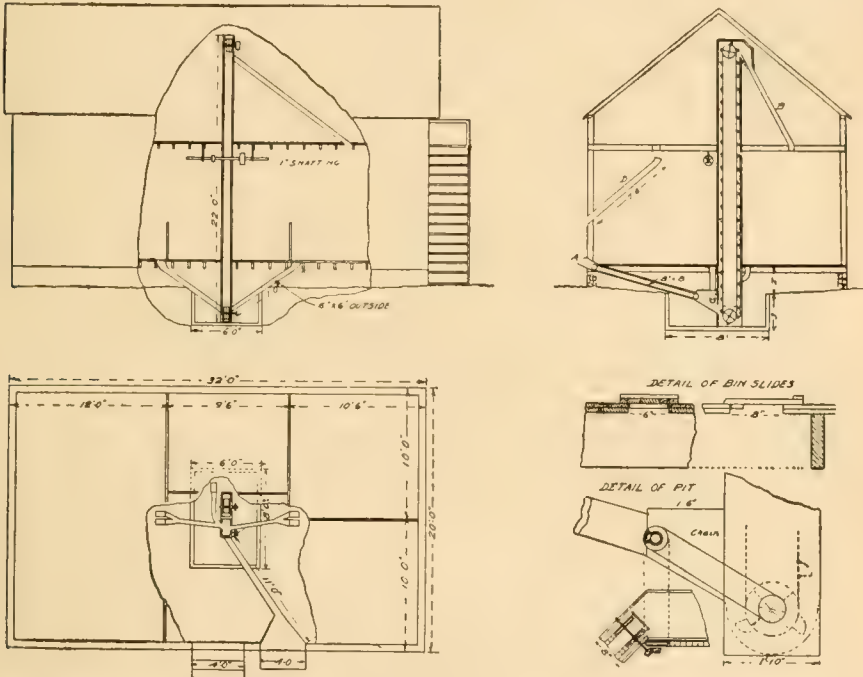

Fig. 1.—A Good Type of Farm Granary for Average Sized Farm, showing arrangement of a simple elevator for handling all grain.

Courtesy of the Minnesota Experiment Station

elevator and other machinery. The desired speed is secured, of course, by the use of different sized pulleys.

Construction—The pit should be 3 feet below the surface of the ground and 5 feet below the first floor. It should be lined with concrete to make it durable and water-proof.

The elevator is 22 feet long and 10 inches by 1 foot 10 inches on the outside. It is set down into this pit. The unloading spout A is 8 x 10 inches, outside measurement. All other spouts are 6 x 6 inches. The pulleys used in the upright elevator are 12 inches in diameter with an 8-inch face. All other pulleys need not have more than a 4-inch face.

Their diameter must be regulated by the speed of the engine. The drag at A consists of two endless chains with slats attached at 8-inch intervals. It is run by means of chain and bevel gearings from a 6-inch sprocket wheel attached to the shaft at the boot of the elevator. For this size elevator a 3 x 3 x 8-inch galvanized iron grain bucket will be large enough. The buckets should be bolted to the belt at intervals of one foot.

Cost—The cost of the elevator described here is \$60.51. The entire cost of the building, elevator installed, should not be over \$600.

Conclusion—A good grain elevator of this type enables the farmer to change damp grain from bin to bin and so prevent heating. He can clean the grain which he threshes and so obtain better prices. And he can hold grain at will until the market is favorable. Such an elevator would pay for itself in a very short time.

CHAPTER XII

THE POTATO WAREHOUSE

I. REQUIREMENTS. II. TYPES. III. PLANS—No. 1—BASEMENT TYPE—SPECIFICATIONS—ELEVATING SYSTEM—No. 2—FOR STORAGE ON A LARGE SCALE—SPECIFICATIONS—HOT AIR FURNACE. IV. CO-OPERATIVE POTATO WAREHOUSE.

Because of their bulk and perishable nature, which makes storage difficult, the potato crop cannot be thrown on the market in the fall in large quantities. The market becomes glutted, and the price falls far below the cost of production. For this reason, potato growers will find co-operative warehouses indispensable. It will enable them to hold potatoes until the market becomes favorable and a good price may be obtained.

Requirements—The requirements of a good potato warehouse are: good drainage, construction to permit the maintenance of an even temperature of about 34° F., and a convenient arrangement.

When basement cellars are constructed, care should be taken not to go below the level of the water table in the soil. It is better to put in the floor above the danger line and grade up to it than to run any risk of flooding.

Artificial heat should not be used in a storehouse if it is possible to keep the potatoes from freezing by any other method. It is impossible to properly distribute artificial heat, and potatoes near the stove may cook while those in the more remote parts of the building are freezing. The best way to keep the temperature up is by means of double or felt-paper lined walls, and a good ventilation system. The latter may be some form of the King system.

The most important thing of all is convenience. The potato harvesting season is a busy one, and the handling of the crop must be rapidly done. Potatoes are so easily injured that machinery cannot be effectively used in handling them. This throws a great deal of manual labor into the task and makes convenience of arrangement doubly necessary. About the only machinery which has been successful is the sack elevator, which will be described later.

Types—There are three types of potato warehouses: the outdoor cellar type, the combination cellar and above-ground type, and the above ground storehouse.

Concerning the first very little need be said. The construction is identical with that of the root cellars described in Chapter XIII. They are usually situated on individual farms, and vary with the amount of potatoes which the farmer raises.

The most common type is the cellar and above-ground type. There are

numberless variations in the plans of this sort of warehouse, many of them offering excellent suggestions to the would-be builder. Several of the best will be taken up in detail, so that one may get an idea of the best constructions.

Plans — Figs. 1, 2, and 3 show complete plans for a warehouse of the basement type.

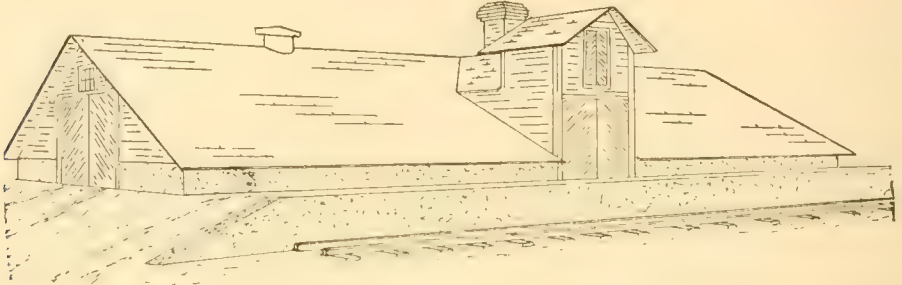

PERSPECTIVE OF POTATO WAREHOUSE

Fig. 1

Courtesy of the North Dakota Experiment Station

Note the gable through which the chute extends into the cars for filling. The raised platform comes flush with the train doors and is convenient in loading small amounts or unloading materials.

In Fig. 2 note the pit in the plan of basement. This is where the lower end of the sack conveyer rests. The entire floor is made of concrete, sloping in on all sides to the pit, from the bottom of which a drain tile removes any water which may accumulate. The foundation walls can be made either of hollow tile or concrete, provided they are made thick enough and strong enough to withstand the pressure of the potatoes. These tile walls may well be extended through to the roof. The dead air space within them makes an excellent non-conductor of heat, and aids in keeping up the temperature.

The potatoes are protected from the outer wall by an inner wall of boards laid on upright 2 x 4's against the concrete. This is necessary in cold climates where the frost is apt to collect on the inside of cement and tile walls in spite of everything.

Note the 6 x 6 uprights which support the first floor. This floor, when properly supported, can be used as a temporary storage room for excess crops.

The second sketch in Fig. 2 shows the first floor of the building. The openings into the cellar are 2 feet wide and extend the whole length of the building as shown, being covered by trap doors. The wagon enters at one end of the building, the potatoes are dropped through the trap into the proper bin, and the wagon goes straight on and out the door at the other end. By this arrangement the wagons can be accommodated as fast as they come up, and the potato sacks can be distributed to whichever bin the manager desires. The system is rapid and efficient.

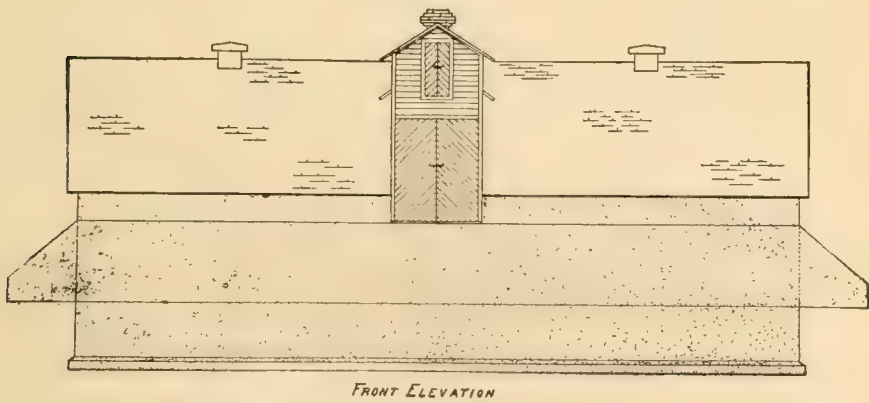
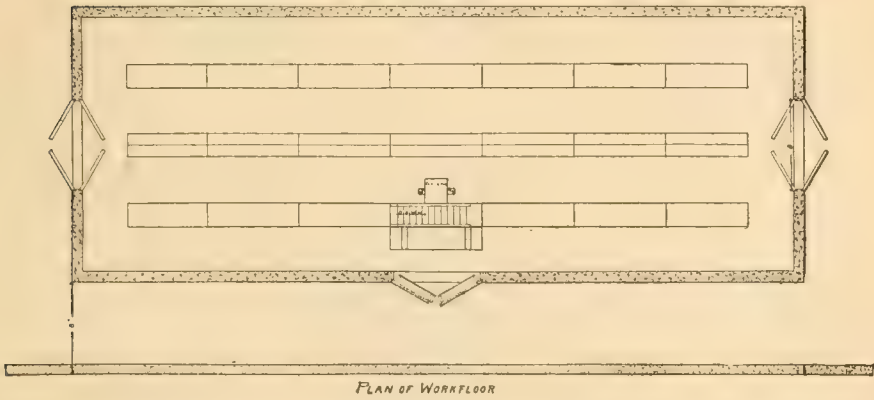
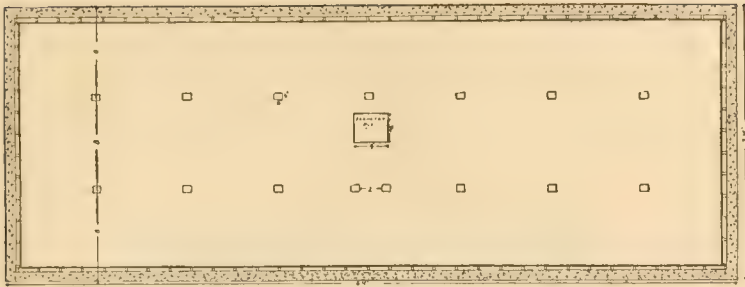

Fig. 2

Courtesy of the North Dakota Experiment Station

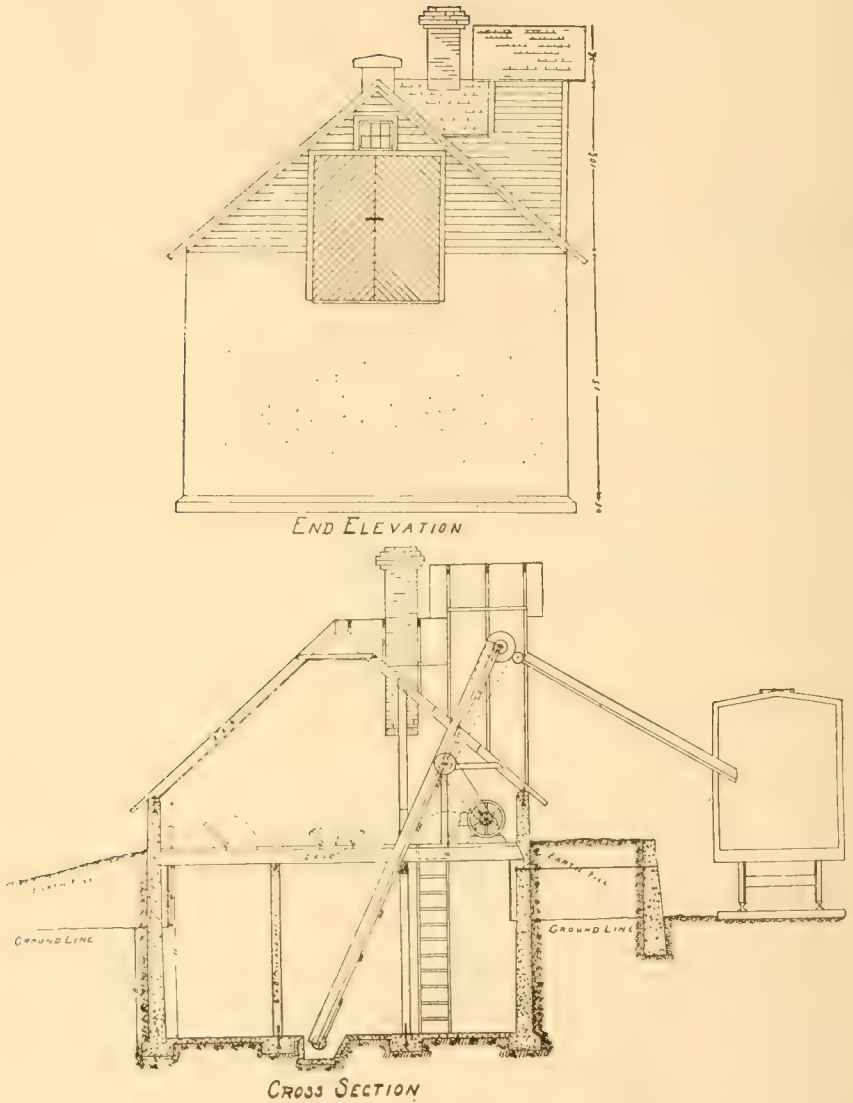

Fig. 3

Courtesy of the North Dakota Experiment Station

Note that the stairway to the cellar is placed beside the elevator. This uses the space beneath the elevator which would otherwise be wasted, and keeps the stairway from cluttering up space that can be better used for storage.

Fig. 3 shows a detail of the elevating system commonly used.

This elevator does not differ very materially from that discussed in "The Granary," except that it is wider, and that 6-inch boards are used on

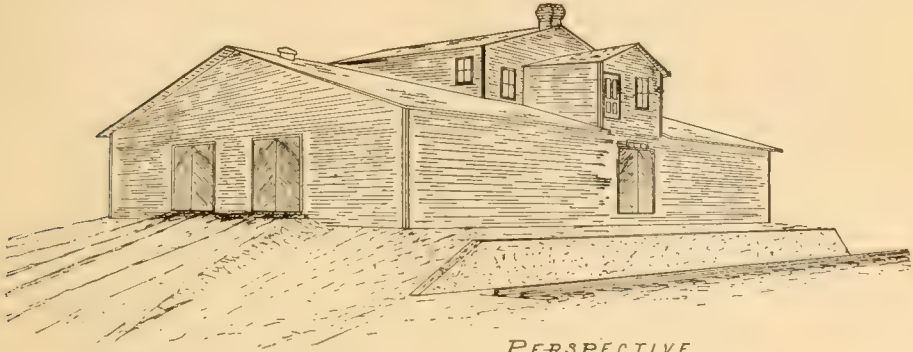

PERSPECTIVE
OF
POTATOE WAREHOUSE

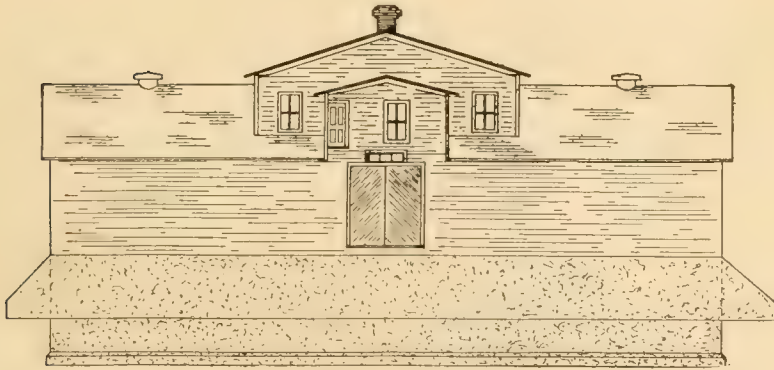

SIDE ELEVATION
Fig. 4

Courtesy of the North Dakota Experiment Station

the elevating belt rather than iron buckets. Potatoes can never be handled in bulk. They are too easily cut and bruised. So they are always stored in sacks. In handling, a chain with patent attachments on which the 6-inch boards rest like shelves is used. The boards are placed 6 feet apart on the drive, and the potato sacks placed on the boards as fast as they come up. At the top of the elevator drive, the sacks are dropped into the chute where they slide by gravity into the car. The end of the chute should be 5 feet

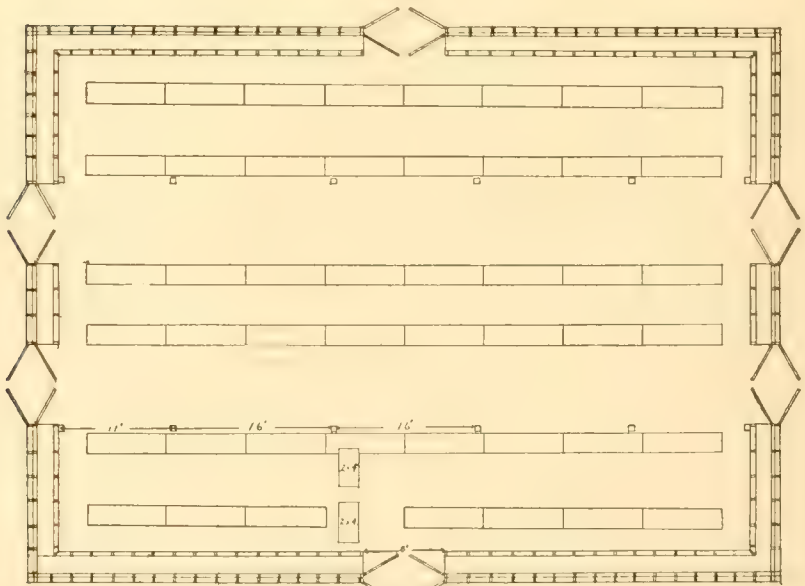
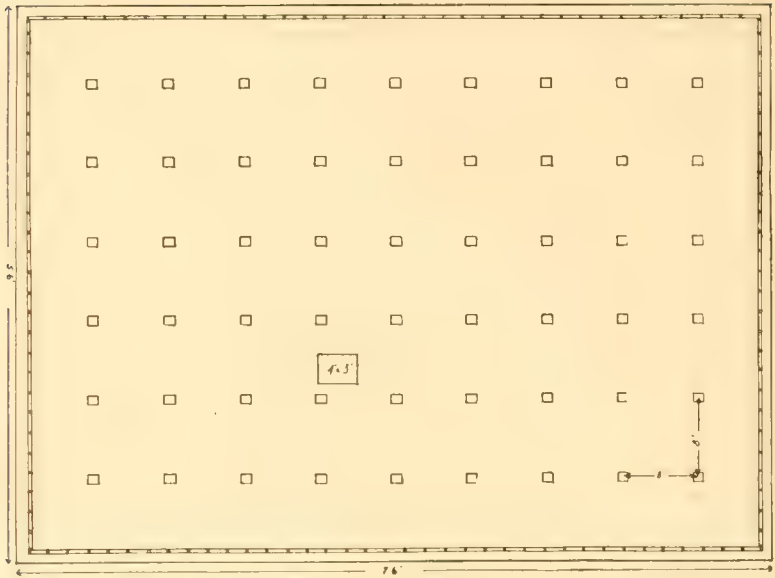
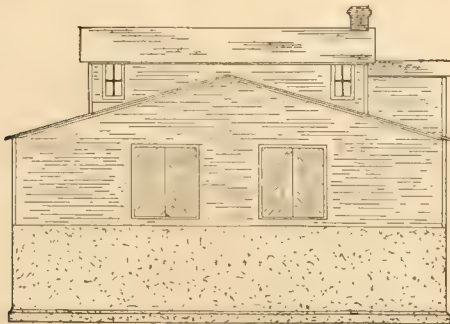
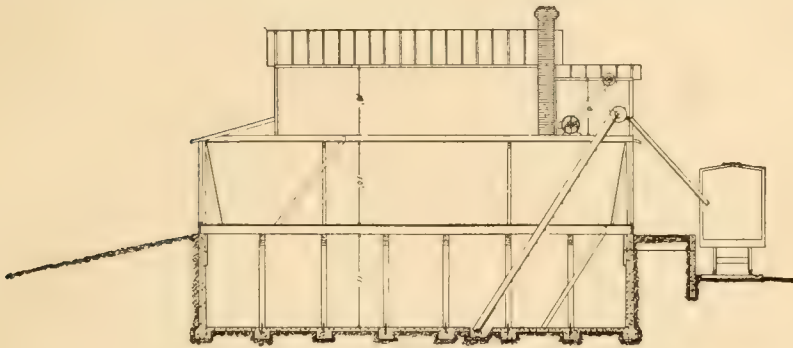
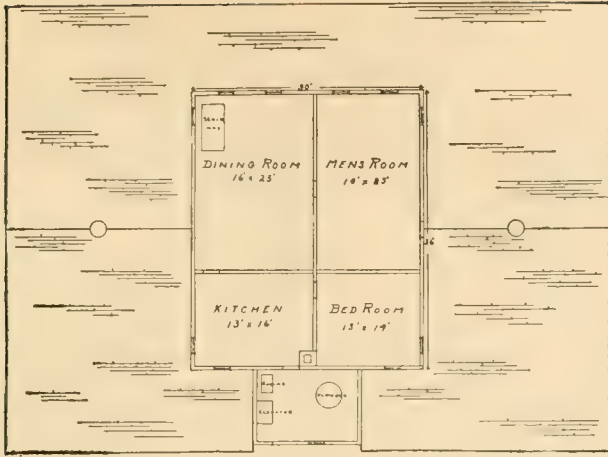

Fig. 5

Courtesy of the North Dakota Experiment Station



END ELEVATION

Fig. 6

Courtesy of the North Dakota Experiment Station

from the floor of the car, so that the sacks may be taken on the shoulder for distribution in the car.

A gasoline engine is usually best for motive power in the country, but an electric motor is cheaper for work in the city. The method of shafting is clearly shown in Fig. 3. The size of the pulleys depends upon the speed of the engine.

Where storage on a larger scale is contemplated, the following building illustrated in Figs. 4-5-6 offers some suggestions.

Fig. 4 shows the perspective and side elevation of such a building.

The first plan in Fig. 5 shows the basement floor. The second shows the first floor. When the basement is full, the traps are closed and this floor is divided into storage bins by movable partitions.

The first sketch in Fig. 6 shows the plan of the second floor. The operation of such a large house requires rather a large crew, and it is desirable that they be housed in the building. The house might also be used by the manager. The second sketch in Fig. 6 shows the detail of the elevator which is larger and operated by a more powerful engine than that for the small house. The end elevation is shown in the last sketch.

Where the business is conducted on such a large scale, a hot air furnace may be installed, with draughts forced by fans and run by the gasoline engine. This is primarily used for heating cars to the proper temperature before loading, but may also be used to heat the house above the storage rooms. This artificial heating will be found very convenient in winter loading.

The potato warehouse is not an expensive luxury to be indulged in by wealthy farmers. It is a necessity if farmers are to continue raising potatoes. With a co-operative building like one of those just discussed and the proper equipment, the farmers of any community can always put their potatoes on the best market and demand their own price for them.



A Concrete Root Cellar.

CHAPTER XIII

THE ROOT CELLAR

- I. MATERIALS. II. SITE. III. TEMPERATURE. IV. VENTILATION. V. DRAINAGE.
VI. HANDLING CONTENTS. VII. PLANS—No. 1—No. 2—No. 3.

One of the best ways of storing roots and fruit is by means of storage cellar. This can be used for roots all winter, and in summer it forms an ideal place to keep dairy products.

Materials—Storage cellars should always be built of concrete or hollow tile. Wood should be eliminated as far as possible, because it does not last in underground construction.

Site—The primary object of the root cellar is to keep the roots from freezing and at a uniform temperature throughout the winter. A root cellar should never be built on the north or west slope of a hill where it will be exposed to the coldest winds. Low ground should be avoided, for there is a tendency for frost to settle over it. The best site for a storage cellar is on a sloping south-drained hill, where entrance is convenient. It must, of course, be within a reasonable distance of the building in connection with which it is to be used.

Temperature—Cold always goes downward into the soil. It is essential to have the roof of a storage cellar double, with a two or four-inch layer of "dead" air between. Air forms one of the best insulators known for cold, and the hollow tile cellar is always satisfactory. The trouble with

tile, however, is that it is liable to admit water into the cellar. As a precaution, both tile and cement cellars should be carefully gone over with a cement wash.

Ventilation—Storage cellars require good ventilation. This aids in the control of temperature and keeps the odors from becoming unbearable. The best way to secure good ventilation is by means of glazed tiling similar

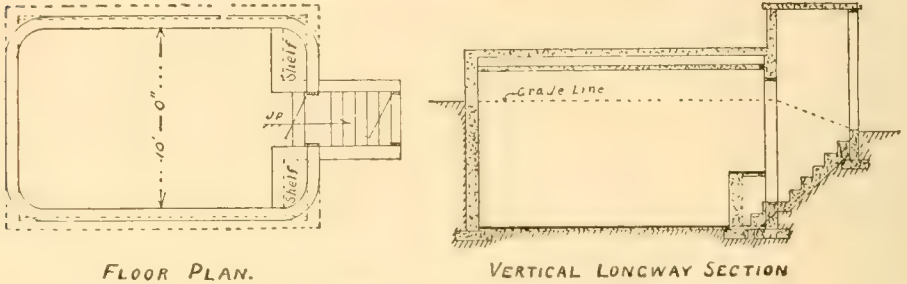

FLOOR PLAN.

VERTICAL LONGWAY SECTION

ROOT OR FRUIT CELLAR FOR LEVEL GROUND

Fig. 1

Courtesy of the Minnesota Experiment Station

to that used in the King system on dairy barn cellars. The inlets open near the ceiling, and the outlets start near the floor and run up through the ceiling. The air comes in at the inlets, mixes with the warm air at the ceiling, drops to the floor, and is swept out through the outlet flues. It is really the King system in miniature.

Drainage—Wherever there is danger of surface water coming into the cellar, a line of tile may be laid around the foundation to drain away

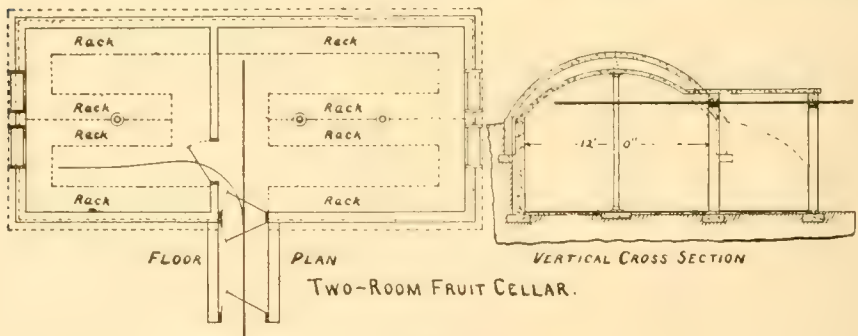

FLOOR

PLAN

TWO-ROOM FRUIT CELLAR.

Fig. 2

Courtesy of the Minnesota Experiment Station

from it. Leaky cellars are a nuisance, and usually worthless. The roof of a cellar should always be water-proof.

Handling Contents—Where roots are stored, they are usually poured through a manhole into the various bins. This manhole can be covered with a double cover like that of a cistern. Where fruit is to be stored, a convenient system of racks and bins must be devised to avoid odors.

Plans — Fig. 1 shows a good storage cellar for roots or fruit. Note the double wall and air space that forms the top of the cellar.

Figure 2 shows a cellar which has been planned for storing fruit and roots. The two important features here are the arched roof, which gives greater height than the average cellar, and the dividing wall, which makes it possible to store fruit in one part of the cellar and roots in another part. The racks in this figure are very conveniently arranged. The construction is rather difficult, as the upper arch is first made with the curved form, and when this has set, the form is dropped six inches and the lower arch laid. Holes are left in the upper arch through which the wet concrete is poured on to the lower forms. Here it is troweled off to the required thickness. The roof is built in sections, much the same as a sidewalk, except that each section is tightly cemented to the next to give a water-tight roof.

This form of storage cellar has much to recommend it in strength and convenience, and is usually worth the extra labor of construction.

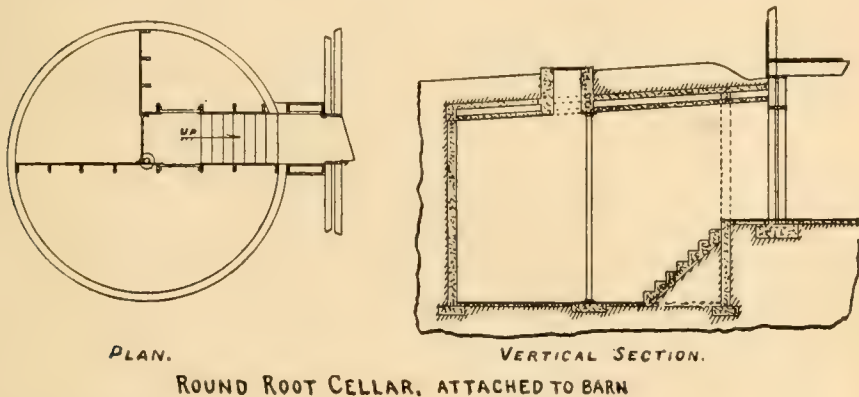

Fig. 3

Courtesy of the Minnesota Experiment Station

Fig. 3 shows a very convenient type of cellar. This cylindrical construction makes a very strong and durable cellar, and one which is easy to clean. Roots are poured through the manhole into whichever bin desired and the manhole is covered with an air-tight cover. The pitch of the roof is for the purpose of securing good drainage.

Although roots and fruit are generally stored in cellars underneath buildings, the outdoor storage cellar is to be recommended; for it does away with the odors attendant upon the storage of many roots and can be often placed more conveniently than a regular cellar. Then, too, one hesitates to build a cellar under a barn, when only a small part of it will ever be used. It would be a needless expense. The outdoor cellar can be easily and cheaply constructed, and is an excellent thing to have about the place.

CHAPTER XIV THE MACHINE SHED

I. IMPORTANCE OF CARING FOR FARM MACHINERY. II. LOCATION OF SHED. III. INTERIOR ARRANGEMENT.

Farm machinery, as a rule, stands idle for ninety-five per cent of the time. Usually it is stored in buildings that have outlived their usefulness and are in a more or less dilapidated condition. Often it is scattered about the farmyard at the mercy of the elements. Farm machinery is expensive. It represents a large investment on the part of the farmer, and is too valuable to be allowed to rust to pieces in the barnyard or in some poorly constructed shed. A dry and conveniently arranged shed should be built for it, with a place for each machine. And then each machine should be kept in its place. It is the height of poor business to let one's machinery go to rack and ruin for the want of proper care and storage.

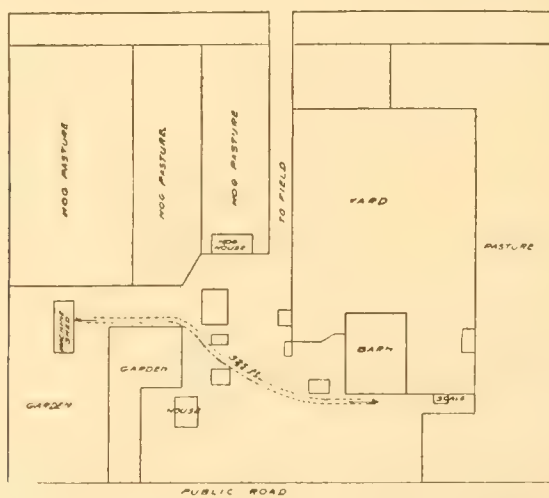

Farmstead No. 1.—Machine shed inconveniently located at great distance from barn and away from the route to the fields.

Courtesy of the Minnesota Experiment Station

The most important consideration as regards the machine shed is its location. Scarcely a day passes but one or more trips to the machine shed are necessary, and if it is not conveniently located, miles of unnecessary travel will be covered during the year and days of valuable time wasted.

1. Name of the vessel
 2. Date of departure
 3. Name of the captain
 4. Name of the commanding officer
 5. Name of the commanding officer's rank
 6. Name of the commanding officer's grade
 7. Name of the commanding officer's title
 8. Name of the commanding officer's position
 9. Name of the commanding officer's office
 10. Name of the commanding officer's department

11. Name of the commanding officer's division
 12. Name of the commanding officer's section
 13. Name of the commanding officer's unit
 14. Name of the commanding officer's group
 15. Name of the commanding officer's team
 16. Name of the commanding officer's squad
 17. Name of the commanding officer's platoon
 18. Name of the commanding officer's company
 19. Name of the commanding officer's battalion
 20. Name of the commanding officer's regiment

21. Name of the commanding officer's brigade
 22. Name of the commanding officer's division
 23. Name of the commanding officer's corps
 24. Name of the commanding officer's army
 25. Name of the commanding officer's navy
 26. Name of the commanding officer's air force
 27. Name of the commanding officer's space force
 28. Name of the commanding officer's coast guard
 29. Name of the commanding officer's marine corps
 30. Name of the commanding officer's special forces

31. Name of the commanding officer's special operations
 32. Name of the commanding officer's special operations group
 33. Name of the commanding officer's special operations team
 34. Name of the commanding officer's special operations squad
 35. Name of the commanding officer's special operations platoon
 36. Name of the commanding officer's special operations company
 37. Name of the commanding officer's special operations battalion
 38. Name of the commanding officer's special operations regiment
 39. Name of the commanding officer's special operations brigade
 40. Name of the commanding officer's special operations division

41. Name of the commanding officer's special operations group
 42. Name of the commanding officer's special operations team
 43. Name of the commanding officer's special operations squad
 44. Name of the commanding officer's special operations platoon
 45. Name of the commanding officer's special operations company
 46. Name of the commanding officer's special operations battalion
 47. Name of the commanding officer's special operations regiment
 48. Name of the commanding officer's special operations brigade
 49. Name of the commanding officer's special operations division
 50. Name of the commanding officer's special operations corps

51. Name of the commanding officer's special operations army
 52. Name of the commanding officer's special operations navy
 53. Name of the commanding officer's special operations air force
 54. Name of the commanding officer's special operations space force
 55. Name of the commanding officer's special operations coast guard
 56. Name of the commanding officer's special operations marine corps
 57. Name of the commanding officer's special operations special forces

Fig. 1 shows an example of a poorly placed machine shed located 325 feet from the barn. This means in a year's time useless travel of seventy-five miles, and a loss of five work days to the farmer.

Fig. 2 shows the proper place to put the machine shed. Here the shed is placed within fifty feet of the barn, and space and time reduced to a minimum.

Sometimes it is a good plan to put the machine shed at the junction of the roads that go to the field and to the highway. This is convenient and means less haulage of machinery and waste of time.

The interior arrangement of the machine shed is very important. Many

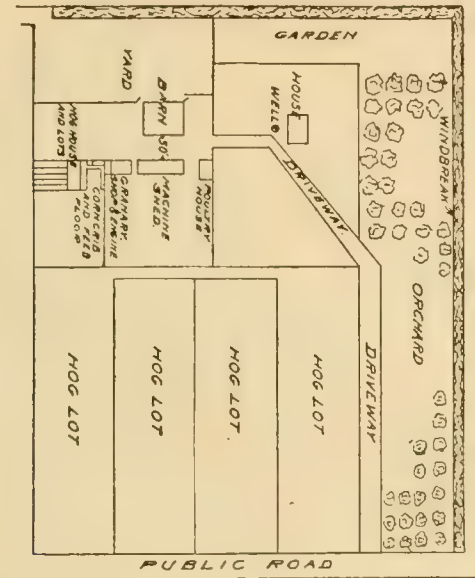

Farmstead No. 2.—Machine shed conveniently located on farm so as to save many miles of useless travel made necessary each year in Farmstead No. 1.

Courtesy of the Minnesota Experiment Station

sheds are built so that the machines are packed in too closely. This means so much loss of time in getting at the implement desired and so much labor in getting it out, that the farmer is apt to leave his machines out in the yard until the season for their use is over. Thus he might as well not have any shed.

The best form of shed is long and narrow, so that not more than two machines can be stored in each place.

The blue print shows an excellent tool shed, and one which can scarcely be improved upon. The dimensions of the shed are 60 x 24 x 8 with a work shop 8 feet wide at one end. A hip roof is put on the building, and this affords a loft for storage of lumber, etc. By means of a block and tackle, light machinery such as the corn planter, potato planter or walking cultivator

can be hoisted to the loft and kept there. The bob sleigh and cutter will probably also be put out of the way up there in summer time.

In this shed, space is allowed for the buggy and the wagon. Some farmers prefer to have a separate shed for buggies, road wagons, cutters, and automobiles. Heavy implements that are used but once, such as the potato digger, and grain and corn harvester should be stored away, back of others that are used more frequently. The farmer should use his judgment in putting away his machinery so that he can get at it best.

The logical place for the shop is in the machinery shed, for most of the repair work is on the farm implements. The well-equipped shop should have a set of carpenter's and blacksmith's tools, a forge and anvil, two work benches, a cabinet with bolt and rivet drawers, a drill press, and other tools. The shop may be made larger and house the grindstone, and in this case it would be convenient to have some power in the shop to drive the drill and grindstone.

How much the farmer will have depends largely upon his own ability and inclinations. But the better equipment a farmer has on his own farm, the less he has to pay to the machinist, blacksmith and carpenter. It pays the farmer to turn machinist during the winter months. The saving of money is not the only consideration; often the value of time saved by doing the repair work at home, exceeds many times the cost of the repair.

A concrete floor should be laid in the machinery shed but not in the workshop. Tools accidentally dropped would be dulled by striking upon concrete. In the workshop a floor of boards or earth is preferable.

The machine shed must be conveniently located. It must be conveniently arranged. It should contain a shop for repairing the broken machinery of farm implements, and slide doors to lessen the work of storing. A little careful planning on the machine shed will save many wasted hours and useless steps. It pays to save time.

END ELEVATION



1/2" = 1'-0"

SECTION

CHAPTER XV

PROTECTION FROM LIGHTNING

I. PRINCIPLE OF PROTECTION. II. PARTS OF PROTECTION SYSTEM — RODS — WIRE — GROUND. III. CONSTRUCTION OF SYSTEM.

Lightning is an ever-present source of danger to the farmer. It destroys more barns than all other causes put together. Yet, because of the expense involved, or because of carelessness and prejudice, many barns are not protected at all.

Lightning, as we understand it, is the passage of electricity from the air to the earth. Air is a very good insulator, and to pass through a layer of air, a great force must be exerted by the electricity. This manifests itself in the flash and in the destruction of whatever the stream of electricity comes in contact with. Iron and nearly all metals are good conductors of electricity; that is, the electricity will flow along a metal rod or wire if it possibly can, rather than cut through the air or across wood. If, then, we can give the electricity an opportunity to flow along a metal conductor as fast as it is formed, it cannot collect in sufficient quantities to break through the insulating air in flashes. The rod does not intercept a flash. Nothing can. It simply dissipates the electricity as fast as it is formed, and prevents the flash.

There are three parts to any lightning protection system, the points, the rods or wire, and the ground. The points are to attract the electricity from the air gradually and prevent a sudden discharge or flash. The wire forms a metallic connection with the ground, so that the electricity will have ready passage. The ground is merely a contact with the water table, to make a good contact with the earth.

In this system the points are made of galvanized iron, cut into 2-foot lengths, and filed to a 3-inch point. These are threaded to screw into $\frac{3}{4}$ -inch galvanized iron tees, which are slipped on the wire and slid along it to the place needed. A piece of $\frac{5}{8}$ -inch gas pipe is threaded to screw into one end of the tee. One end of this piece of pipe is flattened out, holes cut and counter sunk in it for the wood screws, and bent to the proper angle. When the rod goes in place, the gas pipe flange is screwed into the tee, the rod is screwed into the hole drilled for it, and the whole is then screwed to the roof as shown in the first sketch. In general, all high points about a barn such as the ends, cupolas or ventilators, should have points. Care should be taken that the points be as equidistant as possible, for bunching a number of

points together may cause all the charges to jump to one point, and trouble follows.

Wiring a chimney is another matter. Here the cable end is bent up and guyed into place. Then four strands of the 7-strand cable are bent out at right angles, and the tips bent upward as shown in the second sketch. The remaining three wires are twisted together in an upright spike.

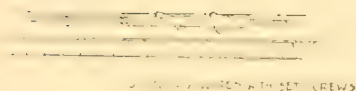
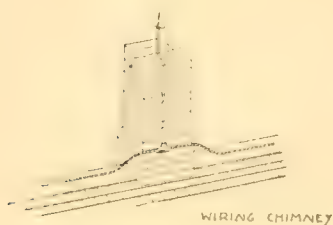
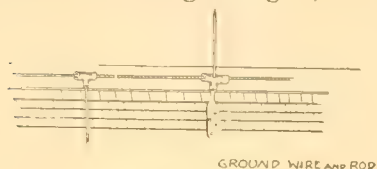

should be cut in the roof instead, and the wire passed down as shown in the fourth figure.

The best way to make a ground, is to bore a hole some 8 feet deep with an old wood auger, tie the end of the cable to a piece of iron rod, and drop the rod down the hole. The ground should always reach the water table, which is usually from 8 to 10 feet below the surface. The space around the grounding wire should be tamped down with wet sand, and the wire put down near a gutter where possible, so that the ground about it may be always damp. Grounds should never be put in near the manure pile as the acids quickly destroy the wire. Neither should they be put down near cattle pens or doors, for they are dangerous at best. Large buildings should have two or three grounds, preferably one at each end and one at the center.

The cable consists of one-half inch triple galvanized iron cable. Three-fourth inch cable can be used just as well and is much easier to handle. This is fastened to the roof with 3-inch staples set two feet apart. Holes should be bored for the staples, for such a large sized staple is more than likely to split the shingles and ridge boards. Care must be taken to get the tees for the rods and grounds in their proper places when wiring, as they are easily forgotten. Wherever there is a cupola in the path of the wire, holes should be drilled in it so that the wire can pass straight through without bending. This is necessary, for electricity is very likely to jump off the wire into the air at bends, causing as much damage as if the barn had not been wired. For this reason the cable should never be bent sharply around the eave trough and into the side of the barn. A hole

Where it is necessary to make a junction, a 6-inch piece of gas pipe is tapped for $\frac{3}{8}$ -inch set screws, the ends of the wires are shoved into the pipe and screwed down by the set screws. Similarly, all tees are fastened to the main cable by $\frac{3}{8}$ -inch set screws. The third sketch shows clearly how the connection is made.

Such a lightning protection for a medium sized barn can be put in for a cost of twelve dollars' worth of materials and two days' labor. It is easily put up, efficient, and inexpensive, and every farmer ought to avail himself of it.

CHAPTER XVI

PAINTS AND PAINTING

I. COMPOSITION OF PAINTS. II. DRYING OF PAINT. III. UTENSILS FOR PAINTING. IV. MIXING. V. PAINTING—PAINTING IRON—REPAINTING. VI. CARE OF BRUSHES. VII. PRECAUTIONS. VIII. COSTS. IX. CONCLUSION.

Composition of Paint — A paint is a mixture of certain oils, known as drying oils; a pigment, which consists of finely divided solid particles insoluble in the oils; and a "drier," usually a compound of lead and manganese which hastens the drying of the paint. Usually a paint contains some "thinner," as turpentine or benzine, which thins out the paint and makes it easier to spread. The most common paints are composed of linseed oil as the drying oil, ferric oxides as the pigment, and turpentine as the thinner, mixed in the proper proportions. For white paints, white lead and zinc white are the only two practical pigments.

The "Drying" of a Paint — We are accustomed to think of drying as the loss of some fluid by evaporation, as the loss of water from paste. The drying of paints is not evaporation at all, but a chemical change which the so-called drying oils undergo in the presence of oxygen. The benzine and turpentine which were used as fillers actually do dry, or evaporate, but the drying oils oxidize and change to a different substance. They become sticky and finally harden, forming a layer like varnish over the covered surface. This layer, while somewhat impervious to water, is not entirely so. Iron will always rust to some extent under ordinary coats of paint. So, to increase its imperviousness and make it more lasting, a pigment is always added to the drying oil to complete the paint. Water cannot get past the particles of pigment and the oils combined so readily as it can go through the oils alone.

Utensils for Painting — There are two brushes which are needed in painting, a round brush with bristles six inches long, and a flat brush four inches wide and about five inches long. The first is good for putting on the first coats, which must be rubbed in, and the second for the finishing coats. There should be a large tin pail for mixing pigments and oil, and wooden paddles for stirring. A wire rack for brushes can be made in a few minutes, and the brushes can be left in their proper places.

Mixing — It would be a hopeless task to lay down any definite rules for mixing. Each paint manufactory has its own set, which is given either on the cans or in a booklet upon purchase. When large jobs are to be taken up, it is cheapest to buy the pigment and oil and do your own mixing. The paste pigment should be used rather than the powder, because it mixes more

evenly and easily. When a can of paste pigment is opened, however, it must be used at once, as it soon dries up. The "drier" should never be used in greater proportions than one pint to two gallons of paint, as it then hinders rather than aids drying. For small jobs it does not pay to do your own mixing. The-ready-mixed cans should be purchased.

Painting—The resin and tars in wood destroy the drying oil in paint. For this reason the best practice in painting would be to let the building stand for six months unpainted, until the resins had all seeped out and been destroyed. But unpainted buildings are unsightly. So most farmers paint their buildings immediately after building. When this is done, the sap veins and resinous knots in the boards should be carefully gone over with shellac of some sort. The first coat of paint should be thinned but little, and rubbed in hard. It is really the protective coat of the house, and should soak into the cracks and knots in the boards. It is immaterial what color it is if it is toned down so as not to show through the two outer coats. This should be left on a couple of days, while the nail holes and cracks are filled with putty. The putty should be put in at this time rather than before the first coat, as it sticks better. Then the other two coats should be put on, making the last coat rather thick to secure a glossy finish.

Bright colors should never be used either inside or out, because they fade quickly, and make the house look old before its time. Good color combinations, such as brown and white or green and white add much to the attractiveness of the place, and often make a good selling feature. It is not necessary to use white always—tan and brown shades are often used very effectively for house bodies. It is merely a matter of the farmer's taste.

Interior decorations do not require three coats of paint. More thinning can be used in them than in the outside coats, and they need not be so carefully rubbed in, because there is not so great a need of protection from the elements. But the interior painting requires more careful color combinations and greater taste than the exterior. Here glaring colors become hideous.

Painting Iron—The parts of all machinery which are of either steel or iron must be painted to prevent rusting. Ordinary paint is not very effective in this respect. Iron and steel rust underneath the paint because of the water which gets through it. The best paint for iron, which is used in steel structural work the world over, is red lead. In painting new machinery, which is always covered with a film of grease as it comes from the factory, the iron parts should be thoroughly scoured with some cleaning material or benzine. They should then be painted immediately. Sometimes machinery is allowed to stand for six months before it is painted. This accomplishes the same thing.

When old machinery is painted, the rust must be taken off with a steel brush before the paint is laid on, otherwise it will continue to eat into the iron beneath the paint coat.

Repainting — In repainting a building care must be taken that every bit of checked and scaling paint is removed. All doubtful places on the building should be gone over with a blow torch and flat-edged scraping knife, and the old layer of paint removed. (Usually there will not be many places on a house, unless it is in poor repair.) It can then be repainted, using three coats wherever the paint was burned off.

Care of Brushes — Brushes which are more or less in use throughout the year should be kept with the bristles always wet in a can of turpentine or gasoline. When brushes are put away they should be thoroughly cleaned with turpentine and then water, and wrapped in paper to prevent dust from accumulating on them.

Precautions — The pigments of many paints are poisonous. When painting one should always clean up and change his clothes before meals. Never, under any circumstances, should the painter get any paint into his mouth. If he does he had better hitch up and go to the doctor.

The oils and fillers of many, in fact, most paints are highly inflammable. The farmer who thinks he can go up on a ladder with a blow-torch and a paint can will surely have trouble ahead of him.

There are more frauds in the paint industry than in any other business except real estate. No one should ever buy a can of paint that has not the maker's name on it and the list of ingredients in plain sight. If the name is not there, one can be sure that the maker is not proud of his product. If the ingredient list is not there, one may be buying chalk mixed up with a little corn oil.

Costs — Colored paints are least expensive. They cost from \$0.75 to \$1.25 a gallon. White lead paints range from \$1.00 to \$1.50 in price. White zinc paints are a trifle more expensive, being rated at from \$1.50 to \$1.80 a gallon. Red lead for iron and steel painting is the highest priced of all, costing regularly from \$1.80 to \$2.00 a gallon. The difference in price is due entirely to the difference in pigment costs, as the price of linseed oil and the driers is the same for all paints.

Conclusion — Paint is not only an ornament — it is a protection and a preservative. It should be used because it keeps weather-boarding from rotting and iron and steel from rusting. It should be used because it adds twenty years to the life of a barn. It should be used because it doubles the useful life of farm machinery. It should never be considered as an ornament, but as a cheap and efficient protection from weathering.

BOOK VIII

WEEDS

WEEDS
CHAPTER I.
NATURE AND KINDS OF WEEDS

- I. INTRODUCTION. II. CLASSIFICATION. III. ANNUALS—BIENNIALS—PERENNIALS.
IV. METHODS OF REPRODUCING AND SPREADING.

Introduction — Weeds have become a serious menace to the farmers of the United States. Laws have been passed to control their spread, but laws are quite ineffective in the face of indifference or carelessness. Every year clouds of Canadian thistle and sow thistle or milkweed seeds are allowed to sow themselves broadcast through the country. Threshing machines move uncleaned from farms that are badly infested to farms where practically no weeds are found. Farmers continue to purchase and sow seed that contains much weed seed without stopping to think of the trouble they are laying up for themselves later. Little can be expected from the laws until the farmers are fully awakened to the importance of controlling weeds, not only in their own fields, but throughout the countryside; then they will unite with each other, with the state experiment stations and with the legislatures in a determined stand for improvement in this unfortunate agricultural condition.

It may be hard to believe that there are districts in the United States which have become veritable weed patches. Whole farms have been abandoned because the weeds have multiplied and spread so rapidly that the farmers have given up in despair. Noxious weeds are spreading at a rate which has alarmed those who are acquainted with the situation. Farms on which quite 25 per cent of the crop-producing capacity has been destroyed by weeds are only too common. What this means to the owner of a one hundred and sixty-acre farm has been worked out in the following problem: Twenty-five per cent of 160 acres is 40 acres. At thirty bushels per acre this area should produce twelve hundred bushels of barley. With barley at sixty cents per bushel the crop would be worth \$720. With land worth \$100 an acre, the farm would have a value of \$16,000. A loss of \$720 on a \$16,000 investment is a loss of $4\frac{1}{2}$ per cent — surely more than the average farmer can afford to bear.

Space will not permit a discussion of methods for control and eradication of each individual weed, nor is this necessary, for many of them have the same life periods, and their ways of reproducing and spreading are alike or similar, so that the methods for combating and eradicating one will apply to many others.

Classification — We shall therefore first classify and discuss weeds in a general way, and then dwell briefly on methods of eradicating a few weeds individually, which are most troublesome, and which are of the most economic importance at the present time.

In order to combat weeds successfully one must have a knowledge of these points: (1) How long does the plant live? (2) How does it reproduce and spread?

Life Periods of Plants — With respect to duration of life there are three classes of plants, viz.: annuals, biennials, perennials.

An **annual** comes up from seed, bears flowers and seeds and later dies, all within one year. Common mustard and foxtail are examples.

A **biennial** grows from a seed but produces only leaves the first year. The root and sometimes the leaves live through the winter. The second year a flower stalk comes up, seeds are produced and the plant dies. Bull thistle and burdock are examples of biennial weeds.

A **perennial** lives on year after year unless the root is killed in some way. Depending upon conditions, the plant may or may not produce seed every year. Quack grass, Canada thistle, toad flax and common plantain are examples of perennial weeds.

Methods of Reproducing and Spreading — Plants reproduce in various ways: by seeds alone, by roots alone, by seeds and roots both, and by runners, suckers, etc. Practically all annual plants reproduce by seed only. Biennials and winter annuals also, except for the one winter through which the roots live, reproduce by seeds.

Perennials may propagate by means of the roots only as does the horse-radish, which in many places is a troublesome weed. Canada thistles in many cases spread only by the roots and bear no seeds, while in other instances, where the conditions are favorable, a large amount of seed is produced. The wild morning glory growing in cultivated ground often produces no seeds but spreads rapidly by its roots. There are other noxious weeds which reproduce and spread both by seed and root like the ox-eye daisy, the snapdragon or butter-and-eggs, the bouncing-bet, perennial sow thistle, quack grass, and several more that are less troublesome.

The importance of knowing the habits of any weed lies in applying this knowledge to the eradication of the plant. For instance, it would be expensive to summer-fallow a field merely to kill an annual weed such as wild mustard which can be kept from spreading by any method that will prevent it from bearing seed. Whether the root is removed from the ground or not, is of little consequence if no seeds are allowed to form. On the other hand it would be equally unwise to attempt to destroy quack grass by preventing it from bearing seed when, in many cases, it really spreads more rapidly by the underground parts than it does by seed. These are but a few examples to show the necessity of knowing the life periods and habits of growth of the weed under con-

sideration before one undertakes to destroy or control it. Labor, even though enjoyable, is expensive.

It may also be well to hold in mind that almost any sort of valuable plant may become destructive as a weed if allowed to grow intermixed in other crops. For example, one of the most destructive weeds in a wheat field may be another variety of wheat which is difficult to grade out of the seed and yet may spoil the market grade of the product.

CHAPTER II.

METHODS OF ERADICATING ANNUAL AND BIENNIAL WEEDS

I. INTRODUCTION. II. TREATMENT FOR SMALL AREAS—USE OF TAR PAPER—PULLING STRAY PLANTS—CUTTING PLANTS WITH “SPUD” OR HOE. III. METHODS FOR LARGE PATCHES—SPRAYING—IRON SULPHATE—SALT SOLUTION—CULTIVATION—ROTATION OF CROPS—DESTROY WEEDS IN WASTE PLACES.

Introduction—For purposes of eradication, the annual and biennial weeds may be treated alike. Both may be kept from spreading and reproducing themselves by preventing them from bearing seed.

The most common weeds coming under this method of treatment are: kinghead, Russian thistle, wild oats, foxtail, wild mustard, cockle, pigeon grass, ragweed, French weed, shepherd's purse, burdock and bull thistle.

Farmers generally have other farm work pressing at the time when the eradication of weeds should receive almost constant attention. It is important, therefore, that they choose a method of eradication that is both quick and economical. The method to use depends largely upon whether the weeds are scattered or whether they are growing closely in large patches or fields.

TREATMENT FOR SMALL AREAS

Where annual or biennial weeds are scattered, or if the patches are small, there are various ways of eradication. The following methods are recommended.

The Use of Tar Paper for Small Patches—Many farmers who have used tar paper for smothering recommend highly this method of treatment. The use of paper is not recommended for areas exceeding two or three rods in diameter. The weeds should be cut close to the ground just before the plants bloom and then covered with tar paper or some other good grade of building paper that will not warp or tear easily. In laying the paper, see that the strips lap sufficiently to prevent plants from making their appearance between the strips. Also extend the paper well beyond the edges of the patch so as to shut out sunlight and air from plants in the extremities of the patch. If after the paper is laid, scattered plants should occur outside the covered area, cut or pull these out. The use of paper is recommended for patches of annual and biennial plants, and especially for ground infested with perennial weeds such as quack grass and Canada thistles.

Pulling Stray Plants—Where only stray plants occur, they may

be pulled up and dropped in the field if the seed pods have not been formed. If, however, the pods are formed the weeds should be carried to a place where they can be burned because the plants often possess enough vitality (in other words, the stems and leaves have stored up enough plant food), to ripen seed after the plants have been pulled up.

Cutting Plants With "Spud" or Hoe — Another method in common use for scattered plants is to cut the plants with a "spud" or with an ordinary garden hoe. The plants must be cut below the crown of the root, otherwise new shoots will start from this point, growing very rapidly due to the vigor of the well developed root, and will produce seeds in a comparatively short time. This necessitates a second cutting.

METHODS FOR LARGE PATCHES

Often the farmer will find that through sowing impure seed or through careless management large areas are more or less thickly infested with weeds. Too much time is required to pull or "spud" each individual plant. He must resort to other methods. He may either spray with chemicals, adopt a system of rotation, do thorough cultivation, or he may adopt a combination of these methods to conform with his particular system of farming. Chemical sprays for some weeds, especially for wild mustard, are sometimes very effective. This method of eradication should be resorted to only when the field is found to be badly infested with weeds after the grain crop is well started. Many weeds can be destroyed without the slightest injury to the grain crop. The most effective spray to use is a solution of iron sulphate. The solution should be made up at the rate of 75 to 100 pounds of iron sulphate to 50 gallons of water.

The spraying must be done before the plants pass through the blossoming stage in order to prevent any of the plants from producing seed. Use a sprayer that is under high pressure, preferably 100 pounds to the square inch so that a fine mist is thrown, covering every portion of the plant. The spray should be applied on a fair day after the dew is off, and, if rain falls within one or one and a half days after the first spray, a second application must be made.

The cost of spraying per acre with iron sulphate varies, depending on the locality, the time of the year and the price of labor. In most localities the cost will not exceed \$1.15 to \$1.25 per acre. This appears to be an economical method of getting rid of weeds. But remember that only plants that are in the grain field at the time of spraying are destroyed. It affects the present crop only, and does not destroy the millions of seeds that may be buried in the soil and ready to grow as soon as conditions for growth become more favorable. Spraying may,



Fig. 1.
The
"Spud."

therefore, be looked upon primarily as a means of controlling weed development while producing a cereal crop.

Ordinary salt is also used to good advantage in solution for the destruction of weeds. If salt is used in place of iron sulphate the solution must be made stronger. One hundred and twenty-five pounds of salt in a vinegar or kerosene barrel of water is recommended for most purposes.

If it is found that after thorough cultivation and spraying one season, the land is still badly infested the spraying may be continued two or three seasons when most of the weeds will be destroyed and the remainder can be gotten rid of economically by pulling and by the use of the hoe or "spud" as described under the heading "Treatment for Small Areas."

Cultivation — Farmers have found that thorough and careful preparation of the seed-bed and good management of the field after the removal of crops, are great factors in keeping annual and biennial weeds in check. The method used by Mr. Nellon near Norwood, Minnesota, for a number of years to keep weeds in check is worthy of mention:

In the fall, as soon as the crop is removed the fields are thoroughly disked to a depth of three or four inches. Then the land is dragged with a slant-tooth harrow. In dragging he does not drag the same direction as the disking was done, nor does he drag at right angles, but at an angle half way between the two. He finds this angle of forty-five degrees to be the most effective for leveling the surface which is thrown, more or less, into ridges by disking. By doing this work early in the fall, the weather is still warm and the soil moist enough to germinate most weed seed on, or near, the surface of the soil. Thus few weed seeds remain in the soil for the following season's growth. This preparation of the "seed-bed" for weeds in the fall usually starts their growth but not early enough to mature seed before they are killed by autumn frosts.

This cultivation is also beneficial for other tillage purposes such as the conservation of soil, moisture, etc. In a system of rotation in which corn follows grain, the farmer may apply barnyard manures directly to the disked field. Thus he conserves the maximum amount of nitrogen in the manure; because it is incorporated more or less at once with the soil, and leaching from the manure by fall rains is carried directly into the soil, not washed away on the surface, as is often the case where manure is applied directly to undisturbed surface soil. The field thus prepared is usually plowed in spring and given thorough cultivation in preparation for the corn seed-bed. If yard manures are so used, care should be taken to have them as free of weed seeds as possible. The corn cultivation can be expected to destroy any left over after the fall working.

If the land is plowed in the fall, a hard crust is usually formed on the surface by spring. By breaking this, which can be done effectively with a disk harrow (Fig. 2), the young weeds will soon make their appearance above the surface and can be killed by subsequent cultivation. This early spring disking will not only kill a number of plantlets before they mature their seed by exposing them to the sun and drying winds, but will also help warm up the soil, making conditions ideal for weed-seed germination which is later killed by cultivation and fall freezing as mentioned above.

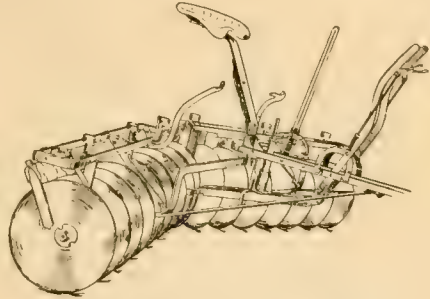

Fig. 2.—DISK HARROW

A splendid tool to stir the winter-packed soil, thus exposing to the deadly work of wind and sun the young weed plants which start their growth with the first signs of spring.

By the use of the light spike-tooth harrow after sowing a cereal crop, before or even after the crop makes its appearance above the surface of soil, weeds can be killed and kept in check to a remarkable degree. In case of corn this is very beneficial. Mr. Nelson makes it a practice to drag his corn or other cultivated crop at least two or three times before the crop appears above the surface, and if the weeds are prevalent after that time, he drags the field once or twice more with a light spike-tooth harrow.

Many farmers hesitate to drag corn, potatoes, or wheat early in the growing season for fear of tearing out or covering up some of the young plants. If the dragging is done in the middle of the day, or when the plants of corn or other crops are somewhat withered, the damage done is negligible. More weeds will be killed by one dragging while they are young and tender, than by several cultivations when the plants have become larger and have a well developed root system.

The value of thorough cultivation can not be over-emphasized. Not only are weeds eradicated but the soil is put into an ideal condition for the action of beneficial bacteria in the soil; it is warmed and ventilated, making conditions better for the germination of the seed and thus giving the crop a strong and vigorous start. Cultivation in fall and spring, as above indicated, also tends to eliminate or hold in check the various root destroying fungi and parasitic insects which attack farm crops.

Rotation of Crops— Perhaps one of the best means of successfully combating weeds is by rotating the crops grown upon the infested fields.

A good rotation, especially for the dairy farmer, is one requiring four years and may include the following crops:

First year — Corn with clean cultivation.

Second year — Grain crop (with clover, 8 pounds; timothy, 6 pounds).

Third year — Two crops of clover and timothy hay.

Fourth year — Timothy meadow or pasture.

For the second year of the rotation, barley, oats, flax or spring wheat may be grown, as best suits the farmer's needs or convenience. In the fourth year a crop of timothy hay may be cut or the field pastured, whichever plan best meets the needs of each particular farm. The sod should be manured in the fall and the field made ready for corn the succeeding spring. The degree of success obtained with this or any other rotation is largely dependent upon persistent cultivation of the corn or other cultivated crop. Short rotations are generally more satisfactory for weed-control than the longer series with less frequent cultivation. The establishment of a good crop rotation on a field is usually a guarantee that annual or biennial weeds will be largely destroyed, and that even the perennial weeds will be partially controlled.

In the above named rotation, if the corn is removed for silage, kept clean and cut close to the ground when harvested, the field can be left unplowed and the land prepared for grain simply by disking. The disking should be done early in the fall to allow the grass seed to germinate. The field should be disked again in the spring. If the corn has been kept reasonably clean and if the disking is done carefully, there should be few weeds to contend with in the crop-bearing portion of the soil. If the land is plowed instead of disked it will be difficult to eradicate the weed seeds which are brought to the surface and they will start a new crop of weeds in the grain crop. Another disadvantage of plowing the corn land to be seeded with grain and clover, is that the plowing destroys the fine firm seed-bed which was formed by the corn cultivation. Cereals, small grain crops, should usually be seeded in the spring as early as possible. All weed eradication therefore, should be done in the fall. If the above rotation is properly carried out practically no weed seed will be produced for a period of four years and at the end of that period, in most soils, few seeds which remained in the soil will have germinating power.

Continued rotation for the more persistent annual and biennial weeds is absolutely necessary. Some of them are known to have produced seeds which retained vitality and germinated when brought near the surface after having been in the soil for many years. There are instances, though rare, on record where over twenty-five years' abode in the soil has not destroyed the germinating power of mustard and various other seeds.

Few farmers realize the rapidity with which weeds will multiply and spread if left undisturbed. The enormous amount of seed that a single plant will produce is almost unbelievable. At the Wisconsin Experiment Station where actual counts were made it was found that a well developed plant of pigeon grass produced 142,000 seeds, redroot or rough pigweed 330,000, barnyard grass 1,290,000, and the tumble weed 6,000,000 seeds. These are weeds common in fields, and along roadsides, and

should at all times be kept from going to seed, because a single crop allowed to go to seed may be an almost endless source of trouble. For instance, weeds may be left alone in the barnyard where apparently no damage is done; yet the farmer should bear in mind that the seeds can be carried far and wide by birds and by running water, or the weed having mature seed may be eaten by the stock and distributed over the pasture coming indirectly to the fields through the manure heap.

Great care should also be exercised in buying and in preparing seed for sowing. Many farmers are each year sowing, intermixed with their seed grain, more weed seeds than they kill in their weed-destroying efforts during the growth season. Careful grading of the seed to eliminate weed seeds is an essential step in the contest for weed control.

Destroy the Weeds on Roadsides and Waste Places—As indicated in previous paragraphs, roadsides and waste areas are a great source of weed-seed distribution. If the weeds common to farm areas are allowed to freely propagate in such places, careful work done on adjacent fields is often essentially lost. The winds readily drift or carry the seeds long distances and reseed the carefully prepared seed-beds. In the great plains and open wind-swept areas, a little caution exercised in disposal of wayside weeds will pay large returns in aiding the campaign for cleaner farm lands. In this connection, remember that roadside weeds mature many seeds which are blown and drifted about by the winter winds. Cut them before they mature.

One of the most effective means of controlling wayside weeds is to see to it that such areas are properly seeded to valuable pasture grasses, such as Kentucky blue grass, with which no annual weed can successfully compete.

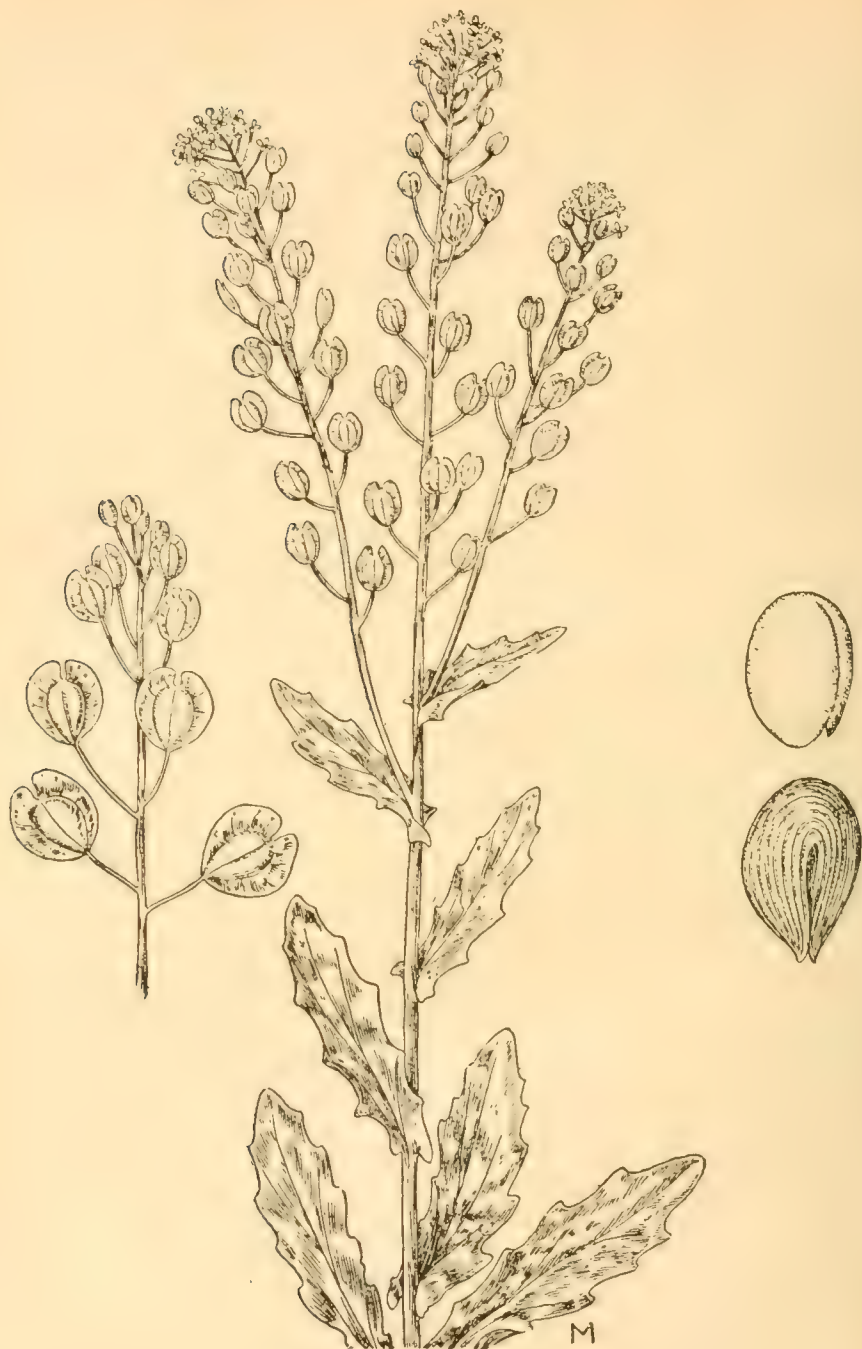

FIG. 3.—FRENCH-WEED.

Penny Cress or Stink Weed.—A winter annual of the mustard family, which is quite sure to be found producing much seed on roadsides and on other waste areas.

Courtesy of the Michigan Experiment Station

CHAPTER III.

THE MOST TROUBLESOME ANNUAL AND BIENNIAL WEEDS AND METHODS FOR THEIR ERADICATION

I. FRENCH WEED—DESCRIPTION—ERADICATION. II. WILD OATS—DESCRIPTION—ERADICATION. III. WILD MUSTARD—DESCRIPTION—ERADICATION. IV. RUSSIAN THISTLE—DESCRIPTION—ERADICATION. V. CHESS. VI. ANNUAL SOW THISTLE.

FRENCH WEED

French weed, also known as Penny Cress is considered one of the worst annual or winter annual weeds. It generally grows from seed in the spring and produces seed before the end of the season. The seed begins to ripen in July and seed is being continually produced until frost. Some of the seed produced in July will fall to the ground, grow and produce seed again the same year; or else the plants survive as winter annuals, and continue growth as soon as they thaw out the following spring, thus producing seed early in summer.

This plant is often known as "Stink Weed" because of its disagreeable odor which is very noticeable. The seed in wheat spoils the flavor of flour; it also flavors the mutton of sheep that eat the plant, and gives a bad taste to milk when eaten by cows.

It will grow in almost any kind of a soil varying in height from six inches to two feet and has white flowers about one-sixth of an inch across. The pods when mature become yellow in color and are about three-fourths of an inch across and much flattened. The seed has concentric rings as shown in Fig. 3. One of its chief modes of distribution results from the blowing about of the light-weight winged pods, each of which usually carries eight or more seeds.

Eradication—Avoid sowing the seed and prevent plants from maturing. This requires constant attention as some of the plants may mature seeds early in the summer and others at later periods leading to almost continuous seeding. The plants may even mature their seeds after they have been covered by the plow if the soil is somewhat dry.

If the weeds are found growing in the grain fields in large numbers early in the season, they may be checked and many of them destroyed by harrowing once or twice with a light, pegtooth harrow when the grain is three or four inches high.

Disking the land as soon as the grain crop is removed will hasten the germination of the seeds. Plow later in the fall and disk or re-plow in the spring. Seeding down to the tame grasses or clovers and alfalfa will tend to bring about eradication.

The following rotation is suggested:

1. Wheat — seed-bed carefully prepared and timothy and clover sown. (If weeds are bad, defer sowing grass seed until grain is harrowed, when three or four inches high.)
2. Timothy and clover hay, two crops.
3. Timothy hay or seed (break in fall).
4. Corn or potatoes.
5. Wheat.
6. Barley or oats.
7. Wheat or flax (seed down).

WILD OATS

Wild oats closely resemble our cultivated varieties of oats and are usually found in fields of wheat, flax, oats, barley and rye. This weed ripens somewhat earlier than most grains, its seed falls to the ground readily and may retain vitality for a number of years. On one farm, a field badly infested with wild oats was seeded down to grass and used for meadow and pasture for a period of seven years, after which it was broken up. Much of the seed buried to a depth of five or six inches grew readily when brought close to the surface by plowing. This power of germinating will vary much according to the nature of the soil, its drainage, etc. If the soil is dry and well drained, such seeds retain their vitality well. If, however, the soil is rather heavy and low lying, they may be expected to decay in from two to three years. On such lands, haying and pasture processes properly handled, soon prove successful in disposing of the wild oats.

To succeed, one must learn to recognize weed seeds in the bin and cease sowing them.

Wild oats can easily be distinguished from tame oats (see Fig. 4). One of the best means of identifying wild oats seed is the horse-shoe shaped scar at the base of the seed which is surrounded by short hairs or bristles. These, however, are sometimes broken off but the horse-shoe scar remains. The weed also has a black, twisted and bent awn by means of which it is capable of being moved about when moistened and dried alternately, a natural feature which tends to cause the seed to bury itself properly even in rather firm soil.

The wild oat is one of the worst annual weeds that the farmer has to contend with, especially where grain farming is prevalent and where rotation of crops is seldom practiced.

Eradication — Stop sowing seed grain containing wild oats. On infested land, grow early maturing crops such as fall rye and barley, that may be harvested before the wild oats mature. If wild oats have matured and shattered out, disk the land immediately after harvesting to encourage germination. The plants that start to grow may be



PLATE 13
WILD OATS. (*Avena fatua* (L).)



Fig. 4.—Two stages of growth of the wild oats seedling (natural size); also enlarged and natural sized drawings of the seed.

Courtesy of the Minnesota Experiment Station.

destroyed by late fall plowing and frost. A rotation of crops which includes a cultivated crop that may be used as a cleaning crop, will greatly facilitate the work.

Wild oats may be controlled in a five-year rotation including: (1) fall rye, (2) timothy and clover hay (two crops), (3) pasture, (4) corn, and (5) barley. A three-year rotation of (1) fall rye, (2) clover hay, two crops, (3) corn for ears or silage, is satisfactory. Cultivate the corn both ways and hoe or pull stray plants by hand if they appear. In case of the barley, if used for the purpose of removing the oats before they shatter, cut the crop as soon as the barley is sufficiently mature. Many fail at this point in the work.

MUSTARD OR CHARLOCK

Wild mustard is one of the most troublesome weeds because of its persistent seeding habit and power of the seeds to survive burial in the soil. Its seeds have been known to germinate after laying in the soil twelve years. It is an annual weed varying in height from one to four feet (see colored plate). The mustard plant is often much branched and is covered with short stiff bristles or hairs. The yellow flowers are quite conspicuous. The pods containing the seeds are about one or one and one-half inches long. They open and discharge the seeds immediately when ripe, which partly accounts for the persistent growth of the weed in a field when once introduced and not immediately checked. Mustard seed may be carried in all cereals and is common in clover, flax and millet. It is easily separated from the larger grains, but not from those of approximately its own size and form. Look out for it in rape and clover.

Eradication—The vital point in the process of eradication is to prevent the seeds maturing and shattering out. In infected fields the land should be worked up with a disk or spring-tooth harrow after the grain is harvested, so as to cover the seeds and induce germination. The plants resulting may be destroyed by fall plowing or by freezing, preferably by fall plowing. The fields should be cultivated fairly early in the spring before the crop is sown, if grain is raised, to kill any plants that may have started. If the cultivation can be kept up until early in May, many of the young plants will be destroyed. A liberal seeding of grain should be made when the soil is well prepared, so that growth may be quickly made and will fully cover the ground. If the mustard starts in the grain many of the weeds may be destroyed by harrowing with a light spike-tooth harrow. If scattering plants appear in the grain, they should be pulled by hand. If, in spite of careful preparation of the land, the field should still be badly infested, the plants may be destroyed without injury to the grain by spraying with a solution of sulphate of iron. To be effective the solution must be applied



PLATE 14
WILD MUSTARD OR CHARLOCK. (*Brassica Arvensis* (L) Ktze).



PLATE 15
RUSSIAN THISTLE. (*Salsola Kali* (L) *Var tenuifolia* G. F. W. Mey).

with a sprayer before the plant passes the blossoming stage. For mustard a 20 per cent solution of iron sulphate is used. Directions for making this spray were given under "Methods for Large Patches."

It should be applied after the dew is off the grain. Secure a spray that will throw a fine mist. The success of the spraying will depend largely upon reaching all parts of the plant with the solution. The cost of spraying varies, depending on local conditions, but it can usually be done at a cost of \$1.00 to \$1.25 per acre.

While spraying is often effective in keeping the weed in check, and is very useful in killing the mustard that is crowding out the grain, yet it must be borne in mind that spraying does not destroy the vitality of seeds that may be buried in the soil. For this reason crop rotation is apt to be the most effective, and in the end, the cheapest method of getting rid of the weed.

In rotations the crops may vary to suit the needs of the farmer. Where grain raising is prevalent it is usually difficult to meet all the requirements of a good rotation, in which case modifications can be used to good advantage. A five-year rotation is here listed: (1) grain seeded to timothy and clover, (2) hay, (3) hay or pasture, (4) corn, and (5) grain.

The hay land should be broken in the fall of the second year and the land carefully prepared in the spring for corn. Thorough cultivation must be given the corn and stray plants must be removed by hand pulling or hoeing.

A good seven-year rotation for grain growers is: (1) barley, seeded to timothy and clover, (2) hay, (3) hay, (4) corn, (5) wheat or flax, (6) oats, and (7) wheat.

RUSSIAN THISTLE OR RUSSIAN CACTUS.

This weed is also known as Tumble Weed. It is neither a cactus nor a thistle, being so called only because of its harsh and prickly nature when mature and dry. It is an annual which grows from one to three feet high and has a spread, sometimes as much as four or five feet. The weed is light green in color and the stem, branches and upper leaves are striped longitudinally with reddish purple lines especially when young. The leaves are small, each tapering to a sharp spine. It is estimated that one good sized plant will produce up to 175,000 seeds in the months of September and October during which time the bulk of the seed is matured. In autumn the stem becomes very weak near the ground, breaks off, and because of its profuse branching of a bushy character, it is easily carried by the wind, spreading the seeds wherever it may be blown. Thus, the weed may rightly be called "tumble weed." The weed has been quite a pest especially in prairie sections. It has spread very rapidly and is now found more or less abundantly throughout several states.

Eradication—The eradication of Russian thistle is very simple. The main object in mentioning it is to call attention to it so that its present rapid spread may be checked. Prevent Russian thistles from maturing by cultivation and harrowing. The plants are easily destroyed while small, but if they mature, they should be gathered and burned before they break loose and blow away, scattering seeds as they go. Good plowing and careful seeding, or planting so as to occupy the land fully, will prevent the growth of the Russian thistle in most seasons. Plants growing on waste places should be destroyed or burned before they mature to prevent seeds blowing over the fields.

Those who live in the drier wind-swept prairie regions should take special pains to conserve moisture in the subsoil so that the spring seeded areas may furnish sufficient moisture to force the cereals to rapid first growth, for the thistles start slowly and are weak growers in the early season. Seed the land early and use the peg-tooth harrow freely over the grain during the first growth period of the grain.

CHESSE OR CHEAT

Chess or Cheat is a weed which for years caused a large amount of economic loss and much useless discussion because its nature and origin in farm crops was not properly understood. It usually occurred in fields of winter grain, and particularly in winter wheat, in which its chief economic injury was occasioned because of the difficulty of removing the seeds, thus causing loss through dockage and loss of grade due to its injurious effects in the milling processes.

At one time, it was quite commonly believed by many that its occurrence in winter wheat was due to a degeneration of the wheat from winter killing, over fall pasturing or other causes. It is, however, a true species of annual grass which grows only from its own seed. It never occurs in grain, therefore, unless sown there or otherwise introduced by scattered seeds after the manner of wild oats. It is winter-hardy and thus when seeded with wheat in the fall, grows as a winter annual. As it is even more hardy than the common winter grains, under some conditions it may and often does occupy the areas in which the cereal kills out.

Eradication—Learn to know the seeds, which look somewhat like small barley seeds. Grade them out or get clean seed. As its seeds are rather free to germinate, and are rather short-lived in ordinary soils, it will soon disappear under any processes of clean agriculture which may be followed persistently. Almost any short-seried crop rotation which does not introduce the seed by way of the grain sowed will be effective.



PLATE 20
CHESS OR CHEAT. (*Bromus Secalinus* (L).



PLATE 18
COMMON, OR ANNUAL SOW THISTLE. (*Sonchus Oleraceus* (L).)

ANNUAL SOW THISTLE

This weed is widely distributed and because of its rather vigorous seed production and the fact that, like other weeds of this group, its seeds are easily wind-borne on their parachutes of fine hairs, readily becomes troublesome in carelessly worked fertile lands. Unlike its near relative, the perennial sow thistle, it cannot, however, occupy the soil permanently, for it is a strict annual and can be controlled by simple methods. One needs only to prevent it from going to seed, not overlooking its destruction in waste places and to get the neighbors to do likewise.

Plate No. 18 is a very good likeness of the annual sow thistle. All farmers should especially study this plant that they may distinguish it from the perennial form. Its flowers are relatively smaller, more compact and of a somewhat lighter yellow color. Its stems and leaves are relatively coarser and somewhat more succulent. Both weeds exude a milky juice when cut and for this reason are sometimes spoken of as milkweeds. They are, however, much more troublesome than any one of the regular milkweeds.

The annual weed can quite easily be recognized from the perennial form by the single rather sturdy tap root and further by the fact that the individual plants are never connected underground. It is very important not to confuse the two forms, as the simple methods of eradicating the annual sow thistle will be of slight avail against the perennial plant. The seeds of the two kinds are difficult of recognition, being much alike to the casual observer. It is a wise precaution to avoid all grass and forage seeds which show seeds of this general type.

Eradication—In cultivated crops, cut or spud off all individual plants. Sow well-cleaned seed. Keep the plants mown close in waste places where they are apt to grow most rank. In pasture lands, sheep are effective destroyers of this type of weed. If sow-thistle infected hay is used as feed, see that the manure is well composted or else use it before cultivated crops. When the seeds are present in the manure careful surface cultivation is all that is necessary to cause the seeds to sprout and to kill the young plants. Any short-seried crop rotation which makes it possible to take off the crop before the seeds mature is effective.

CHAPTER IV

GENERAL METHODS OF ERADICATING PERENNIAL WEEDS

I. INTRODUCTION. II. DIGGING AND REMOVING ROOTS, BULBS, ETC. III. TREATMENT WITH SALT, ACIDS AND OTHER CHEMICALS. IV. ROOT STARVATION. V. EXPOSURE TO ACTION OF SUN, WIND AND FROST. VI. SMOTHERING WEEDS BY CROP GROWTH. VII. PERSISTENT WORK ESSENTIAL.

Introduction — Perennial weeds reproduce themselves by seeds and also propagate by some form of perennial underground root or stem, as the crown-forming root of the dandelion, the creeping root of the Canada thistle, the root-stock of smart-weed or quack grass and the bulb of wild garlic.

To destroy perennial weeds, seed production must be prevented and the underground portion must be killed. Seed production may be prevented by mowing when the first flower buds appear, the same as in the case of annuals or biennials. The best methods for killing the roots or root-stocks vary considerably according to soil, climate, character of the different weeds and the size of the patch or the quantity to be killed.

In general, however, the following principles apply:

Digging and Removing Roots, Bulbs, etc. — The roots, root-stocks or bulbs, may be dug up and removed; this remedy can be practically applied only in small areas. For this purpose an ordinary five- or six-tined potato fork is a very effective and convenient tool to use in the lighter weight soils, but a mattock or grub hoe will be found more effective in heavy lands. The patch should be watched afterwards so that any stray plants can be removed as soon as they make their appearance.

Treatment With Salt, Acids and Other Chemicals — Salt, coal oil, or strong acids applied so as to come in contact with the freshly cut roots or root-stocks destroy them for some distance from the point of contact. Crude sulphuric acid is probably the most effective of comparatively inexpensive materials that can be used for this purpose, but its strong corrosive properties render it dangerous to handle. Carbolic acid is less corrosive and nearly as effective. Arsenite of soda, a dangerous poison, is sometimes effective applied as a spray on the growing weeds. Gasoline has been used to some extent during recent years with good effect for such weeds as Canada thistles, milkweed or sow thistle and dandelion but is almost useless for quack grass.

For use on the farm, where the patches are small or where plants are scattered, ordinary salt, for such weeds as Canada thistles and

milkweed, is probably as economical and efficient a material to use as any. Cut the weed just below the surface and place, in a large funnel shaped hole (made with a knife or other convenient tool), a large handful of salt, or half a pint of stiff salt brine. This funnel shaped hole is shown in Fig. 5. Where the weeds are not too well established one treatment is sufficient but two treatments will kill all the weeds almost without fail. The salt treatment is especially effective where stock is pastured because their efforts to get the salt will greatly help to destroy the weed. Scatter some rock salt over such pasture areas.

Root Starvation—Roots are starved to death by preventing any development of green leaves or other parts above the crown. This may be effected by persistent, thorough cultivation in fields, by the use of hoe or "spud" in waste places and by salting the plants as just described.

The Tar Paper Method—In this connection, as indicated in Chapter II, the tar paper method of smothering small areas of perennial rooted weeds is by far the most certain and effective procedure. This will be further emphasized in Chapter V.

The rule for controlling or eradicating perennial weeds is: "Never allow any part to show green." Do this in any way most convenient to the specific case. It is necessary for such plants to produce green leaves to feed the underground stems or parts. If we cause them to fail in this, root starvation must follow and the treatment succeeds.

Exposure to Action of Sun, Wind and Frost—Most roots are readily destroyed by exposing them to direct action of sun during summer drought or direct action of frost in winter. In this way plowing may become effective. Plowing in late fall, infested fields that have been previously cultivated so that roots are exposed on the surface and are killed, is one of the best ways to keep perennial weeds in check. If the crop is harvested and removed rather early, and the ground plowed and frequently disked and harrowed until shortly before it freezes, the roots deeper in the soil are so starved of plant food, and so lessened in vitality that a late plowing, thoroughly done, will expose these weakened roots and a surprisingly large number of them will be killed by frost. Moreover, the frost will have a tendency to loosen the roots from the soil, which facilitates the dragging of the roots to the surface where they can be dried and burned. The spring-tooth harrow as shown in Fig. 7 is a very useful implement for this purpose.



Fig. 5.

Weed cut off just below surface and salt placed in a funnel-shaped hole made with hoe or other tool. The salt dissolves when wet by rains, making a brine which kills the root.

The depth of the underground roots of perennial weeds varies with the different weeds, the kind of soil, and the kind of cropping system in use. It is essential, therefore, that the farmer first ascertain the depth of plowing so as to turn them evenly to the surface. A good type of plow to use is shown in Fig. 8. Do not drag cut portions of the weeds about, thus distributing them to larger areas. In this connection it is wise to stake off the worst areas so as to work them separately and more thoroughly.

In meadows or pastures or any other place where the plants are not cultivated or otherwise disturbed, the root-stocks of quack grass will be found in the upper two or three inches of soil, while in culti-



Fig. 6.—GOOD PLOWING NECESSARY TO ERADICATE WEEDS

The depth of the plowing should be regulated so as to turn the root stocks to the surface.
Courtesy of the Wisconsin Experiment Station

vated or otherwise loose soil the root-stocks may extend in some rare cases to a depth of ten or twelve inches. They continually work nearer to the surface.

Smothering of Weeds by Crop Growth—Plants may be smothered by dense sod-forming grasses or by crops like hemp, buckwheat, clover, alfalfa, cowpeas or millet, and by fodder corn or canes seeded broadcast. Such crops tend to exclude the light and starve out the weeds. In selecting a smother crop choose one that is well adapted to the climate and soil on which it is to grow, one that can be utilized to good advantage on the farm. On a dairy or stock farm, millet or buckwheat is undoubtedly as good as any to use. To encourage rapid growth, a

preparatory treatment of an infested field should include the application of fifteen or twenty loads of manure per acre. This method of treatment is criticised by some because of the increased vigor it gives to the weeds. If, however, the field is given thorough cultivation from the time the crop is removed the previous fall, including also a late fall plowing to expose the underground roots, the weeds are so sapped of their vitality that they cannot recuperate enough to compete with the rapid growth of the sown crop. If, therefore, manuring is accompanied with persistent and thorough cultivation, its use is highly recommended. Rapid growth is almost useless unless very dense. Sow at least half again as much seed per acre for smothering as is used for ordinary cropping. If the crop is millet, mix in about three or four pecks of oats. Oats and millet make a most excellent combination for hay. Oats and field peas also make a good crop for this purpose on certain types of soil.

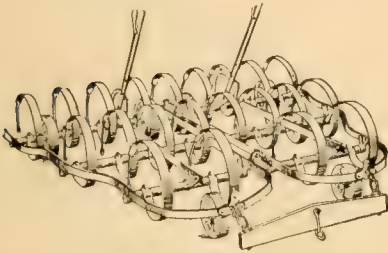

Fig. 7.—THE SPRING-TOOTH HARROW

One of the very best tools to drag the roots of Canada Thistles and other noxious weeds to the surface of the soil where sun and wind can kill them.

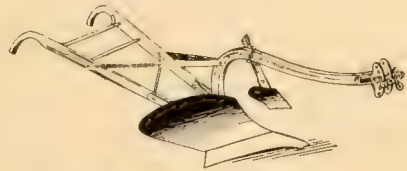

Fig. 8.—PLOW FOR KILLING WEEDS

The style of plow to be used in plowing grain or cornfields. It will turn the roots well up on the surface and cover all litter which might hinder the necessary cultivation.

For all perennial weeds with the exception of quack grass, alfalfa has been found to be an excellent smothering crop where a good stand has been secured. Alfalfa not only makes rapid growth, thus shading the ground, but the fact that it is cut two or three times every season prevents weed seed from maturing. To secure a good stand, the ground must be heavily manured and plowed as early in the summer or fall as possible and cultivated as already described, continuing the cultivation until early June, when the seed-bed should be carefully prepared and alfalfa sown at the rate of twenty pounds per acre.

The preceding treatment will have weakened the weeds. The manure will give the alfalfa a good start and provide a rapid growth so that the alfalfa will soon shade the ground sufficiently to prevent the thistles from growing. This method of treatment has been tried by a number of farmers who declare it an economical and effective method to use where a good stand of alfalfa is secured. On western semi-dry land areas a somewhat lighter seeding will probably give a sturdier, more effective growth of alfalfa.

Persistent Work Essential — Any cultivation which merely breaks up the root stocks and leaves them in the ground, especially during wet weather, aids in their distribution and multiplication and is worse than useless, unless the cultivation is continued so as to prevent any growth above ground. Plowing and planting corn ground in the spring, and cultivating it at intervals until the last of June, then leaving the ground uncultivated during the remainder of the season is one of the best methods that could be pursued to encourage the growth of most noxious perennial weeds; nor does it do what it should do, namely, prepare a proper seed-bed for the following crop.



PLATE 16

COUCH, QUACK OR SCUTCH GRASS. (*Agropyron repens* (L) Beauv).

CHAPTER V.

THE MOST NOXIOUS PERENNIAL WEEDS AND METHODS FOR THEIR ERADICATION

- I. QUACK GRASS—DESCRIPTION—ERADICATION—PURE SEED LABORATORIES. II. CANADA THISTLE—DESCRIPTION—ERADICATION—ERADICATION IN SMALL PATCHES. III. PERENNIAL SOW THISTLE OR MILKWEED—DESCRIPTION—ERADICATION. IV. OX-EYE DAISY. V. WILD BARLEY. VI. CONCLUSION.

QUACK GRASS

Quack grass is considered one of the worst weeds in the Northwest. It is a perennial plant living from year to year unless prevented by some unusual circumstance. It grows to a height of from one to five feet, depending upon the fertility of the soil and the character of the season. There are numerous underground stems commonly but improperly called roots. These underground stems seldom appear more than six inches below the surface of the ground. At short intervals on the underground stem at the joints, buds appear from which can grow new plants. Any portion of this stem containing a bud is capable of producing a new plant.

Quack grass may be propagated by underground stems as well as by seeds and these can be scattered by the farm implements used for its eradication; it may be distributed by being carried around in horses' hoofs, or the grass containing the ripe seed may be eaten by stock and distributed all over the farm through manure.

The most common way in which quack grass is distributed in a community is through the purchase of brome grass or slender wheat grass seed. These seeds are so much alike that the weed can be detected only by the experienced eye. This together with the fact that they are very difficult to separate by means of cleaning machinery makes the purchase of brome grass and slender wheat grass seed very risky. Never buy them before satisfying yourself that what you get is absolutely clean seed. Care should also be exercised in the purchase of oats and other seed. Where clover is grown in quack grass infested areas, much quack grass seed is liable to be hulled along with the clover seed and will be found in mixture with it.

Eradication—Professor Boss of the University of Minnesota Agricultural College says:

“Smothering by plowing and thorough bare culture is the best means of eradicating quack grass. The best results will follow when the treatment is given in hot dry weather after the root systems have been somewhat exhausted by the growth of plants. The seed should not be allowed to mature, however, but if mature, the grass should be cut and burned.



Fig. 9.—There are three grasses the roots of which are sometimes mistaken for those of Quack Grass before the heads are grown. Beginning at the left they are: Kentucky Blue Grass, Red Top, and Smooth Brome Grass. When the heads are compared with the Quack Grass at the right the difference is readily seen.

Courtesy of the Wisconsin Experiment Station.

Where a field is badly infested, it should be plowed deeply from five to eight inches, as soon as the hay or grain crop is removed, preferably by August 1 to 15. The plowing must be well done and all portions of the plant completely turned under. A jointer on the plow will aid in turning the grass under. The plow should be followed within a few days by a disk harrow with disks set nearly straight to avoid inverting the sod. The purpose is to fill the spaces between the furrow slices, thus stopping the free circulation of air. Following the first disking the land should be double disked frequently enough to prevent the appearance above the surface of any quack grass leaves. This will be twice a week in warm moist seasons and once a week when the weather is drier. The disking should be continued until growth ceases, usually from six to eight weeks. To make sure of eradication it is well to disk occasionally until freezing weather in the fall.

The following spring cultivation should begin early and may be continued at intervals of a week or ten days until May 15 or 25, when the field may be planted thickly to fodder corn. Thorough cultivation of the corn with hand hoeing where occasional plants appear in the rows, should complete the eradication, but extreme watchfulness is required to get rid of all the plants.

This intensive cultivation is expensive and is called for at times when the farmer is very busy, but there seems to be no better way to eradicate the weed completely. The cost of cultivation is in many cases returned in the increased yield of the crops following.

Short crop rotations are useful in keeping quack grass under control and when arranged so as to provide an opportunity to attack the quack grass at seasonable times, they will permit eradication of the weed without losing the use of the land. A good two-year rotation for this purpose is ensilage corn after fall rye. Plow the land after removal of the rye, disk, and prepare for ensilage corn the next year. Plow the land after harvesting the corn and sow the rye immediately.

The following three-year rotation may be used: (1) Fall rye or barley, seeded to clover in spring; (2) clover hay (first crop), plow between July 15 and August 1, and disk as above; (3) ensilage corn with thorough cultivation. A fall rye, corn, barley and clover rotation may be managed so as to eradicate the quack grass between the first and second years.

The advantage in using this method of eradication is that no crop is lost. It takes, however, at least two or three years to entirely free the field of the weed.

When it is desired to destroy in one season, no crop can be raised and the bare fallow method must be employed. The disadvantage of eradicating the weed during one season is not only that the crop is lost but also that cultivation must be done at frequent intervals during the entire season. Cultivation must be done most thoroughly in the spring of the year at which time other farm work is pressing and the farmer is

apt to neglect the quack grass patch until spring work is done, thus giving the weed a vigorous start and consequently making it hard to subdue.

The Pure Seed Laboratories — Too great care cannot be exercised in selecting the seed to be used for seeding down hay and pasture areas. A few quack grass, Canada thistle or sow thistle seeds mixed with the good grass seeds means great loss in crop and much labor in the near future. Many states and the United States Department of Agriculture now run laboratories for the purpose of giving aid to all growers and seedsmen. If you do not know the seeds of these chief weed pests, send samples of the seed you intend to use to your State Pure Seed Laboratory or to the United States Department of Agriculture at Washington, D. C., for analysis.

CANADA THISTLE

Like quack grass, the Canada thistle is a perennial plant. In height it ranges from one to three feet, depending on conditions. The Canada thistle has no root-stock like quack grass, but true roots, the parts of which are capable of producing new plants. The roots are about a quarter of an inch in diameter, almost white in color and it is from these that new plants are thrown up at intervals as they extend their length through the soil. These horizontal roots are found at various depths. When undisturbed the roots are apt to lie within six or eight inches from the surface, but they go sometimes to a depth of from two and one-half to three feet where the soil is cultivated or loose and porous in character.

Like quack grass, Canada thistle propagates by seed and by runners. The method of propagation by running roots is shown in Plate 17. Each seed carries a tuft of downy hair, by the aid of which it can be carried any distance by summer winds. Seed, therefore, carried by wind is the greatest source of spreading. Where grasses and clover are allowed to ripen for seed, Canada thistle, if any exists in the field, will produce ripe seed at about the same time. Thus it is that seed shipped into a new community is often a prolific source of introduction. Make sure to get clean seed when buying. It will save lots of money, work and consequent worry.

Eradication — The weed can be successfully exterminated by cultivating or fallowing without a crop, provided the land is not too wet. When the bare fallow method is used no crop can be grown during the season in which the treatment is given.

It is recommended by some that the field be plowed at least four times during the season. In the intervals between the plowing, the cultivation of the field must be frequent enough to prevent any leaf growth above the surface of the ground. This can be accomplished by the use of a cultivator, a spring-tooth harrow, or any other implement or tool that



PLATE 17
CANADA THISTLE. (*Cnicus arvensis Hoffm.*)

will drag the roots to the surface. It takes but a comparatively short time to destroy the vitality of roots when exposed to the sun and to the drying winds of summer. In the spring and occasionally in the summer, if the ground is hard or has a tendency to become so, a disk harrow is a very good implement to use. This tool puts the soil in a loose and friable condition, thus facilitating subsequent cultivation as will also a disk harrow. The objectionable feature in its use is that the roots are not brought close enough to the surface for thorough and immediate drying. The use of a disk harrow is especially objectionable and its use is of little account where the soil is wet, because the roots are cut up into short stubs or pieces, nearly every one of which will start a new plant. This scatters the weed more than ever. Plowing and disking may be profitably begun the season previous to bare fallowing just after the removal of the crop. If cultivation is done thoroughly and persistently during the summer, neither quack grass nor Canada thistle can survive the treatment. If adverse conditions prevail and there is any doubt about the complete eradication of the weeds, the field should be plowed early the next spring and cultivated thoroughly until corn planting time, when the field is planted to corn, in check rows to admit of thorough cultivation both ways. The field should then be watched carefully, so that weeds not taken with the cultivator can be destroyed by hoeing. While it is not probable that plants will survive the above treatment, it is well to keep watching, that no weed may be left to start anew.

The fallowing method is more certain to result in complete eradication than any other that has been tried. It gets rid of the weed in one year. The thorough cultivation of the soil leaves it in a splendid condition, so that a much larger crop can be obtained in the following year than would have been possible had the weeds remained, and the field will continue to bear good crops after the weeds are eliminated. For these reasons it is as economical as some method which allows the production of crops but which extends through several years.

The other method which has been successful in most instances and which for that reason is still popular in many communities, is the eradication of the weed in conjunction with growing a crop.

Where the quack grass or thistles are to be removed while the crop is being raised, plowing should begin in the summer or autumn as soon as the grain crop is removed, the earlier the better. This should be followed by careful cultivations during the remainder of the growing season. The next spring cultivation should be done as soon as conditions will permit, and should be continued at frequent intervals until about July 1, allowing no growth above the surface of the ground.

Then prepare a good seed-bed and sow the land to millet, buckwheat or some other quick growing and early maturing crop. Whatever is used, sow thickly to crowd out any weak sprouts that may appear. If followed by plowing again in the fall after the crop is removed, and



Fig. 10.—A Typical Canada Thistle Plant. This shows the long stem root and the horizontal underground root stock or stem. Note the slender leaves and flower branches.

Courtesy of the Wisconsin Experiment Station.



Fig. 11.—The Ordinary Bull Thistle. This plant is frequently taken for its relative, the Canada Thistle. Note the heavy main stem, the thick leaves and large tuft of surface roots with a single tapering tap-root.

Courtesy of the Wisconsin Experiment Station.

by thorough cultivation the succeeding spring, all weeds will undoubtedly be killed. The advantage of this method lies in the fact that it allows a crop to be produced during the process of weed eradication.

Its disadvantage is that it is not so certain to be successful. As to crops which are of special use in this work see Chapter IV.

Tar paper can only be used successfully on fairly level ground where the paper can be held close to the surface. There is little danger of the paper rotting and it can be weighted down with boards, planks, sods or stones. In a dry season sixty days is usually sufficient to kill the weeds, but if convenient, leave the paper on eighty or ninety days to make sure that the roots are dead.

During recent years the use of heavy growing crops for destroying Canada thistle has been very successful. Where good stands of alfalfa or other heavy growing crops have been secured and maintained for three years, Canada thistle can often be completely eradicated.

To secure this the ground should be heavily manured and plowed as early in the summer or fall as possible, and cultivated as already described, continuing the cultivation until May or June the following spring. Then the seed-bed should be carefully prepared and the grass seeded thickly in order to insure a thick, dense mass. This will shut out air and sunlight from the thistles. This method has been claimed a complete success by many farmers who have tried it. In selecting a crop for this feature of the work use tall, leafy, rapid growers; such as corn, cane or hemp. The one selected should depend in part on the use which may be made of it on the particular farm.

PERENNIAL SOW THISTLE

The perennial sow thistle is one of the worst weeds in the Northwest. It is gaining ground very rapidly and is working its way in all directions, and is destined to be one with which many farmers will have to contend sooner or later, unless something radical is done to check its present rapid spread. In some districts many fields are so badly infested that farmers have abandoned them entirely. In the latter part of the summer during high winds, the seeds having tufts of hair attached to them similar to those of the dandelion, are carried for miles and miles and farmers who allow no weed patches in their neighborhood and who plant only clean grain themselves, wonder how their land becomes infested.

Besides being found in cultivated fields where the weed generally gains a first foothold in a community, it is also found in waste places, along roadsides and in pastures and meadows. The weed thrives best in rich tillable soil. The plant varies from one and one-half to four feet in height, produces flowers during the entire summer, beginning the latter part of June, and produces seed from July to the latter part of September.

The perennial sow thistle, unlike the annual sow thistle has underground roots of fleshy, succulent growth, from which new plants appear



Fig. 12.—PERENNIAL SOW THISTLE

1 Underground system of plant; 2 top of plant showing flowering head; 3 seedling; 4 seed natural size and enlarged.

Courtesy of the Minnesota Experiment Station.

at frequent intervals after much the same manner as the Canada thistle. Four or five plants may produce a hundred or more plants before the end of the following year. New plants are frequently produced from the parts cut off by farm tools.

Eradication — The following method of eradication given by Professor Boss of the Minnesota Agricultural College is indeed very practicable: When the first stray plants appear, they should be pulled or dug out before they mature seeds. Constant watchfulness is necessary to detect them. When a field has become so badly infested that the thistles interfere with crop growth, early summer bare fallowing is advisable. Short rotations should be followed in sections where the weed is very common. A three-year rotation of (1) grain, (2) clover, and (3) a cultivated crop with thorough preparation of the land, and clean cultivation will keep the weed in check. The specific treatment that follows will give good results where the weed has become well established. Immediately after the removal of the grain crop, plow the land deeply, preferably early in August. After plowing, disk frequently enough to keep the leaves from starting. The disking should be kept up until frost stops the growth of the plants. Start disking early in the spring or replot fairly early. Cultivate the land frequently until about June 1 and plant thickly to fodder or ensilage corn in rows from three to three and one-half feet apart. Cultivate the corn frequently until it shades the ground completely. Hand hoe, if necessary. Remove the corn by September 15, plow the land, and sow immediately to fall rye. In the spring, sow clover in the rye, and harrow. The following year cut the first crop of hay and plow under the second. Plant corn the next year and work into a short rotation. Where cultivated crops cannot be grown successfully or cannot be used, buckwheat, following early summer fallow, may be grown quite satisfactorily for smothering out the thistles. Vigilance, prompt and thorough cultivation, and short rotations are necessary in the eradication of sow thistles on large areas.

A method somewhat similar to the one just described and which has worked out very satisfactorily on many farms is as follows: Seed the land to winter rye. This can be harvested and removed from the field before the end of July. The sow thistle will, in the first place, be given a severe setback by being cut just at a time when it is coming into bloom. Start disking at once. Do a thorough job of it, crossing so as to be sure that no strips are left untouched with the disk harrow. Where the ground is rather hard or compact, it is recommended that the field be double-disked the first time; that is, lapping over half way on the "return round." Disk frequently during the rest of the season to prevent any growth above the surface. In the late fall just before it freezes up, plow deeply, thus exposing the roots to the action of frost whereby many of them will be killed during the winter.

The following spring cultivate frequently to prevent growth above

the surface. For this purpose use either an ordinary disk harrow, a spring-tooth harrow, or a cultivator equipped with knives or sweeps. These are effective in cutting off the stems a couple of inches below the surface before they have an opportunity to make their appearance.

Cultivate frequently until about June 15, when the ground is prepared and seeded to buckwheat or millet. Sow about three pecks per acre in either case. If millet is used, it is recommended that a bushel of oats be added. Oats make rapid growth and the two combined make a most excellent crop for hay. The object in sowing thick is to have the crop cover the land completely. If any weeds should occur after the above treatment, cultivation can be continued in the fall, after the removal of the crop and the following spring up to planting time. The great advantage of this method of treatment is that no crop is lost during the process of killing the weeds.

OX-EYE DAISY — WHITE WEED

This is a perennial weed introduced from Europe, but for a very long time it has been found in practically all farming districts of the United States, almost everywhere in pastures, hayfields, roadsides and waste places. It is a rather beautiful plant very similar to the chrysanthemum, both in direct relationship and in appearance, though, of course, smaller. The flowers are single. The leaves are characteristically shaped like those of the chrysanthemum, deeply notched in that particular fashion, and are also about of that color. The flower has a large yellow center and the whole plant is not at all unsightly. It is, however, quite a destructive weed, especially in pasture lands in which the fields are liable to be over-pastured. It is also particularly destructive in timothy fields, and great care should be exercised in procuring seed, because this weed seed is very likely to be present in timothy seed.

Eradication — Eradication of the weed is rather simple. All weeds in waste places, roadsides and meadows should be carefully mowed in early June, as the flowers ripen and seed early. Almost any ordinary cultivation destroys it, as the perennial roots are rather shallow, and it is not at all winter hardy when the roots are turned up to the action of frost. They also die by being exposed to sunlight and air-drying for considerable periods of time. In old pasture lands, or hay lands badly infested, all that is necessary is rather shallow plowing late in autumn, planting to corn or other cultivated crop the following year, followed by any short line crop rotation. If pasture lands are infested, sheep and goats are good animals to keep the weeds controlled. The plant will readily be recognized by the illustration on Plate 19.

WILD BARLEY — SQUIRREL TAIL GRASS

Plate 21 is a particularly satisfactory illustration of wild barley. The weed may easily be recognized from this picture. On wet, heavy lands,



PLATE 19

OX-EYE OR WHITE DAISY. (*Chrysanthemum* (L.) Var. *Pinnatifidum*).
(*Leucanthemum* Lecog & Lemotte).



PLATE 21

SKUNK GRASS, WILD BARLEY OR SQUIRREL-TAIL GRASS. (*Hordeum jubatum* (L)).

the grass grows in heavy clumps and becomes a pest in all overpastured areas westward and northwestward through the prairie regions, where its seeds are blown about by the winds of winter and autumn. From its appearance this weed would be judged as a valuable pasture grass. However, it is scarcely eaten at all by stock. It is only grazed down under conditions of the barest pasture.

The weed is particularly detrimental for this reason: that whenever the prairie lands or timothy fields or other pasture lands are pastured close and any bare spots opened up, this grass comes in and rapidly takes possession, gradually occupying a large percentage of the area. It is also very destructive for other reasons. The awns, though appearing very silky and rather beautiful, while the grass is immature, are nevertheless harsh and of a sharp nature, which readily penetrates into any wound or delicate skin. The awns gradually fill the wool of sheep full of the stickers difficult to card out. When cut into hay, the dry awns become a nuisance, penetrating the jaws and working their way into the glands and more delicate tissues of the animal's mouth and throat, producing irritating sores and swellings in the mouth often not dissimilar in external appearance to lumpy jaw. The weed is noticeably a lover of alkaline soils. It seems to be able to thrive in less well drained lands than ordinary cropping plants. Thus, such places are soon overrun with a heavy growth of this grass.

Eradication — The weed usually grows from the seed one year without the production of heads, and later becomes rooted in heavy masses which are essentially perennial, producing the barley-like heads the second and following years. It is not a heavy rooter and therefore any careful plowing and tillage tends to kill out the sod masses formed by it. In pasture lands, avoid over-pasturing and properly drain all alkaline wet places in cultivated fields, particularly in waste places along the roadsides. On pasture lands and on waste places, roadsides, etc., keep all bare spaces and areas in which grass can grow seeded to blue grass. This is the one grass with which, after the sod is well formed, the wild barley has little chance of competing. Keep all areas, particularly in waste places, roadsides, undrained areas of cultivated fields, etc., carefully mown early in the season before the heads are formed sufficiently to scatter seed. The heads break off and blow about.

Wild barley is so closely related to common barley and to wheat that it bears apparently all of the diseases which affect these crops. This is another excellent reason for destroying the weed. The wild barley or squirrel tail carries the chief rusts of wheat and barley. As it is a common wayside weed, and as it matures earlier than the spring wheat or barley, the red rust spores are always present on this wild grass early enough to be distributed in large quantities to the growing wheat or barley. This reason alone should be sufficient to cause farmers everywhere to keep this grass closely mown and under control.

CHAPTER VI.

CONDITIONS WHICH TEND TO BRING ABOUT WEEDY CONDITIONS OF LAND

I. INTRODUCTION. II. WINTER DRIFTING OF SEED. III. EFFECT OF DRAINAGE. IV. SEED CONTAMINATION—SEED ADULTERATION. V. DISTRIBUTION OF SEED AND FORAGE STUFF. VI. BURIED WEED SEED. VII. BARNYARD MANURES, COMPOST HEAPS AS SOURCES OF WEED DISTRIBUTION. VIII. PARASITIC DISEASE—FUNGOUS DISEASES.

Introduction—As indicated in other paragraphs of this book, it is perfectly natural for plants of all kinds to spring up when the ground is idle or improperly handled. This is really a provision of nature which is of great benefit. Many farmers are so anxious to reap crops that if it were not for the constant encroachment of weedy grasses and other plants which occupy and hold down the land, it would become tilled to such condition, and possibly cropped to certain special crops so long, that it would be completely worn out. If the grasses and weeds did not take possession of all the bare areas, the soil would soon be washed away or become a drifting mass very similar to a desert. However, this provision of nature is well understood by most able farmers, and in this text we have undertaken to tell how to fight weeds, not to indicate the benefits which arise from their presence. It is, however, well known by many, that under certain conditions large crops of weedy growth plowed under form a green manure, which, while not of the best type, is a good substitute for preventing an entire loss of humus. Therefore, while no great harm is done from allowing large growths of certain native and introduced plants to occur on one's farm, if plowed under at the proper time, yet great damage may be done by allowing the growth of comparatively small patches of some kinds of weeds to ripen seeds. In this connection it is important to consider some of the causes underlying the growth of weeds.

A very wide range of plants has developed under natural conditions, and each of certain kinds has special ability to occupy immediately the various types of land which may, from various causes either natural or artificial, become vacant or idle. Each plant is adapted to avail itself of some natural means for its seed distribution. Some have their seeds or seed containers so constructed as to be readily carried by wind; some seeds, because of their peculiar structure, float upon the waters; others are swallowed by birds and other animals and distributed with their manure. The most rapid means of dissemination is by means of wind; seeds so sown are for example: the dandelion, sow thistle,

Canada thistle and French weed. The kinghead, wild oats and many other of the grass and weeds seed are evenly distributed by flood waters, so that on poorly drained land or land subject to flooding, the seeds readily take charge of the ground on which other growth is destroyed. Assuming that there are certain destructive weeds present in a community, it is well to remember that uncultivated places such as the roadsides, banks of streams, rubbish piles, and barnyards, will soon have a heavy growth of the weeds which are characteristic of that particular type or condition of soil. There are weeds for the sandy, dry, gravelly knoll; weeds for the alkaline, undrained area; weeds which will immediately take possession of flooded areas as soon as the floods abate; weeds which get their seeds distributed easily through farm operations, particularly through the barnyard, and those that are readily carried about on the coats of farm animals, distributed here and there; last, but not least, some of the weeds are of such nature as to be readily drifted by the winter winds over the snow covered ground, wayside wastes, etc.

Winter Drifting of Seed—The snows of winter in the prairie regions, becoming very much compacted and drifting over extended areas, readily carry large quantities of weed seeds of all types. The Department of Botany of the North Dakota Experiment Station has conducted numerous extended experiments in testing out the content of snow drifts, selecting these drifts many rods distant from any weedy areas. Such examinations always show the content of the snow to be made up of drifted particles of dirt and numerous weed seeds, practically all of the kinds capable of growth in the immediate neighborhood, and often of a variety not known to exist within miles of the district in which the drifts are examined.

One special experiment had to do with the speed with which seeds were drifted over the snow covered ground when turned loose at any given point. In one experiment in which the velocity of the wind was approximately 20 miles per hour, common oats, millet, and other farm seeds were poured out on the surface of the frozen snow, and found at a distance of 80 rods from the point of dissemination within 15 minutes.

Effect of Drainage—Insufficient or improper drainage on heavy lands is immediately noticeable in the increased growth of weeds and difficulty in overcoming them. If the lands are liable to flooding from over-flowed ditches or neighboring streams, all the types of weed seeds which float may be distributed upon the land in large numbers. When the drainage is not sufficient, such heavy lands soon become sour and insufficiently aerated, with the result that cereal crops and other cultivated crops cannot make a normal growth and die out in places; it is to be remembered, however, that there are weeds, such as kinghead, quack grass, and some of the very worst of our native weeds, which

really prefer this condition of soil and soon occupy such land and produce seeds in abundance.

Seed Contamination, Seed Adulteration — Many farmers continue to help the growth of weeds by sowing a large number of the worst types of agricultural weeds with their seed grain and forage crops. In some cases they raise these seeds on their own land. Very often they think they ought to have a change of seed because their crops are getting so poor, and proceed to buy seeds from other districts without investigating to see what new sorts of weeds and disease may be imported, often with results even less satisfactory than before. In bringing in new varieties of seed with which you are not familiar, the best advice that the writer can give is that you reject, for the time being, any sample of seed which shows seeds other than those with which you are thoroughly acquainted, until you have had the sample properly examined and reported upon by some authority on seeds.

Distribution of Seed and Forage Stuff — One of the worst evils connected with the distribution of weed seeds arises from the constant shipping about and distribution of forage plants, hay, straw and seed grains, badly infected by weed seeds. In buying these to feed to stock on your farm, you should inspect them with the greatest care. It has been almost impossible for the different states to pass any legislation securing a proper inspection of such feed stuffs, except in the way of testing out their chemical value. Very often large masses of tumbling mustard seeds and many other kinds of small seeds from the screenings of grain are thrown into bran, and thus when the material is fed to the stock uncooked, millions of the worst kinds of weed seeds are turned loose in the barnyard to be blown about over the farm and to be carried to the fields in the fresh manure. Look well to your feed stuff, whether it be bran, hay or grain. Feed your own screenings on your own farm. It would be wise first to boil them. Mustard seeds and numerous other kinds of seeds with impervious seed coats pass through the alimentary tract of animals, undigested or unchanged, and only sprout the better for having had the experience of this natural trip. Raise some hens to follow the stock.

Buried Weed Seed — Seeds of many types of weeds and grains fail to germinate the same year they are produced, and yet, for some reason, under certain conditions, maintain their viability. Some seeds have especially constructed seed coats, which accounts for their ability to live though dormant. This is well illustrated in the hard-coated seeds of certain of the leguminous plants, such as alfalfa and sweet clover. One seed in a cocklebur usually germinates the first year after maturity, and the other, for no known reason, does not germinate until the next year or some following year. Some wild oat plants produce seeds which germinate in the fall as soon as given opportunity. Another plant growing beside the first produces perfectly mature seeds, which

will not germinate to any extent in the fall, but with plenty of moisture and properly covered will lie in the ground until spring, when it will germinate to fullest extent. Mustard buried more deeply than three inches in ordinary heavy ground, even when the ground is moist, will lie there for years. In the North Dakota Experiment Station, there are records extending over twenty-two years in which the seeds were brought up, dried, laid on the shelf for a few months, and when submitted for germination, germinated completely. This last feature is particularly true of French weed or penny cress seed. While they may not germinate when they are first brought up, if they are exposed and dried for a time, then put back into the ground, they germinate freely. These peculiarities are mentioned just to call the attention of the grower to some of the reasons why it is so difficult to kill weed seeds by plain cultivation when they are once worked into the ground. To leave these buried seeds undisturbed is the main reason for cultivating only on the surface to a certain depth during one season and not reploting. If the top three inches have been cultivated thoroughly and the weed seeds are all sprouted, it is foolish to dig deeper that year or the next spring before the spring crop is seeded, because if this is done, a new supply of weed seed is turned up which will immediately occupy and reseed the ground. Soils vary greatly in their preservation of buried weed seeds. In the average weedy field, where the the weeds have been growing for a number of years, the soil may be assumed to be well filled with seeds to the depth of ordinary plowing. If the climate is dry and the soil is seldom wet up very thoroughly, it may be taken for granted that practically all kinds of seeds, buried too deeply to be reached by air, are well preserved and that they will grow when turned up. This is a fact which must be always kept in mind in trying to control or fight weeds.

Farm Tools as Weed Seed Distributors—In your contest with weeds, do not forget the farm tools. Remember that a muddy toothed harrow dragged over ground infected by disease or weed seed, at certain times, will carry the seed from that area over a great distance of ground. Remember that a spring-tooth harrow, or other tool, dragged through a patch of quack grass lengthways over a large piece of fertile land, will, as it goes, scatter broken parts of that weed and weeds of similar growing habits, gradually distributing them over the full distance that it travels. Remember that the threshing machine should be cleaned before it comes on to your farm. It is better to have your own threshing machine and keep it clean, even though it may be a small one. Remember the fanning mill does not clean its own screens. When cleaning different kinds of grain, be sure to clean thoroughly all parts of the machine between changes of variety. Last, but not least, do not forget the manure spreader. This is one of the most useful tools for saving labor but if

used in spreading fresh manures full of weed seeds of all sorts, it is a great labor producer.

Barnyard Manures, Compost Heaps as Sources of Weed Distribution

— From what has been said in previous paragraphs, it must be evident to the reader that the barnyard and feed lots may become the chief and most constant source of weed distribution on the farm. Even when the greatest care has been exercised, it is impossible to prevent a very large amount of weed seeds in the bedding, the waste from the mangers and the feed troughs, from getting into the final manure as made from day to day. In most cases if this is hauled directly and spread over the land, the weed seeds will be generally distributed either by wind blowing or by direct infection of the soil on which it is spread. If it is hauled from day to day to the compost pile, made in a loose, careless manner and not properly taken care of, the compost pile itself will become a source of great weed distribution when that manure is used. While the old fashioned barnyard, in which the hogs stayed close to the cattle, and the chickens stayed close to the hogs, and the manure and bedded straw were thoroughly worked over and trampled by the different farm animals, was perhaps wasteful of manure value, it may be said not to have been the worst of evils; for such manure, as was used under these conditions, was generally apt to be rather free from weed seeds. Many farmers make a mistake in handling the compost heap, in that, when they start to haul out the manure from one of the heaps, in which the composting has been done properly in the central portion, they forget to remove the outer covering of the pile. It should be remembered, that even though there are very few weed seeds in the manure when brought out to the compost piles, that the winds will have filled the outer portions of these piles rather full of various sorts of seeds, and that the heat from the composting will not have been great enough to kill the seeds on the exterior. The exterior should always be removed and placed in the bottom of a new pile. When hauling manure from the old barnyard, the strawy portions should first be removed and laid to one side for further rotting and treading upon.

Each farmer must use his own good judgment in regard to the use of fresh manure. He must consider his particular needs, keeping in mind just how much cultivation and how much pasturing, is going to be done on the land immediately following the introduction of the fresh manure. Under certain conditions it is perfectly safe to spread the manure on the stubble of hay lands. The stubble and grass will keep the seeds from getting into the soil, and if they sprout on top, they will be choked by growing grass or destroyed by the cattle if the land is pastured. If manure is to be worked into the land, it should be spread on the stubble of cereal lands, preceding corn culture or in some definite cultivation system which will result in the destruction of the seeds before they become thoroughly incorporated into the land. Manures full of

weed seeds should never be immediately plowed under to a depth of eight or ten inches, so that the seeds may lie there and be brought to life whenever they come to the surface.

Parasitic Disease — Fungous Diseases — Let it be remembered that many of the parasitic diseases of farm crops are nothing more than minute plants growing either in the soil, or upon the roots, or the straw or stem portions of the farm plants. They are thus to be looked upon as weeds in the same sense as the larger weeds with which we are familiar. While their seeds are spoken of as spores, they serve the same purpose as the seeds of weeds. Thus we have smut spores, ergot spores, rust spores, flax wilt spores, and spores of potato blight and scab, all likely to be present in manure just as are the seeds of the various weeds. When fresh manures containing these spores are spread upon the land, the fungi not only attack the immediate crop, but fill the fertile soil and the partially decaying manure with pure cultures of these organisms, to such extent that very often the farm crop is badly injured or reduced in its market value. Therefore, another reason for thoroughly composting manure in a proper and efficient manner is self evident. If the composting is not done, the fresh manure should not be placed upon the same kind of crop from which it was taken. If, for example, flax is to be grown on the land within the next three or four years, never put barnyard manure containing flax straw on the land ahead of the flax crop; but rather put it on the flax crop stubble so that the other crops in the rotation will be grown there, and the flax fungi or parasites, particularly wilt and rust, may be starved out or killed off by cultivation and crop rotation. This little excursion into the subject of disease is made here to show how parallel the cases are. Weeds choke out the crop by cutting off the sunlight and using up the food materials. Fungi, minute parasitic plants attack the crop plant, sap its life, use up its vitality, and disqualify the seed and other products.

Whatever might be said of weeds, this should be borne in mind: the farmer should know weeds so that if new weeds are introduced into his community, he may go about in the right way to stop their growth. If new weeds are found on your farm, or if seeds of an unknown nature are observed in the grain or forage seeds which you are about to use as seed, send a sample of the seed to your Experiment Station or to the nearest Pure Seed Laboratory, to be identified. Inquire whether it is an annual, biennial or a perennial, and eradicate as described under those heads in this discussion.

The homely yet true expression, "A stitch in time saves nine," can be applied in the eradication of weeds. Go after your weeds at once before they become too well established. Get your neighbors to do likewise. You will be rewarded for your efforts,

SUMMARY OF INFORMATION USEFUL IN THE RECOGNITION OF WEEDS.

Name	Origin	Time of Flowering	Time of Seeding
Burdock	Europe	July to September	August to October
Bindweed	Europe	June to September	August to October
Blue Weed	Europe	July to October	August to October
Canada Thistle	Europe	June to August	July to September
Couch-grass, Twich, Quack	Europe	June to July	July to August
Chess	Europe	June	July
Corn Cockle	Europe	June to July	August
Cow Cockle	Europe	July to August	July to September
Campion, White	Europe	June to August	July to August
Campion bladder	Europe	June to August	July to September
Dock	Europe	July to August	July to August
Dodder	Europe	June and July	Aug. and September
False Flax	Europe	June to August	July to August

Characteristics	Duration	Place of Growth	Method of Control or Destruction.
Erect branching with large roots	Biennial	Everywhere	Cut off below the crown, and if in seed, burn the tops
Running or climbing vine	Perennial	Grain field and gardens	Difficult to eradicate, constant cutting below the surface
Erect, hairy	Biennial	Fields and waste places, sand and gravelly soil	Thorough cultivation is always sufficient. In fence-corners, etc., cut below the crown
Creeping, from a jointed root stock	Perennial	Fields and gardens	Constant cultivation is about the only effective remedy
A coarse grass	Annual	Fields and waste places	Hand pulling in grain, and avoid fall sown crops. Sometimes taken for degenerated wheat
Erect, branching, flowers purple	Annual	Grain fields	Sow clean seed. Hand pulling in grain
Erect, branching, hairy, flowers pink or white	Biennial	Grain fields and waste places	Sow clean seed. Hand pulling in grain. Cultivate stubble lands two or three times in the fall
Erect, bushy, flowers pale pink	Annual	Grain fields, etc.	Hoeed crops, summer fallowing where very bad
Erect, branching, flowers white	Perennial	Everywhere	Likely to become troublesome. Frequent cultivation of infested fields and hand-pulling
Leaves, with strongly curled margins; flower, stem erect from a spindled shaped yellow root	Perennial	Everywhere.	Cut off below the crown with hoe or cultivator
Parasitic, climbing over other plants, and feeding on their sap	Annual	Mostly in fields and gardens	Sow clean grains and seed. Hand-pull it before it ripens seed. Likely to become very injurious
Erect, branching, flowers small, yellow	Annual	Cultivated fields	Fall cultivation of stubble fields. Hand pulling in grain
An erect grass	Annual	Everywhere	Frequent fall cultivation. Plant hoe crops on infested land

Name	Origin	Time of Flowering	Time of Seeding
Orange— Hawkweed, Paint-brush	Europe	July and August	Aug. and September
Hare's Ear	Europe	June to August	July to September
Hound's Tongue	Europe	July and August	Aug. and September
Lamb's Quarters	Europe	June to October	July to November
Mustard Charlock	Europe	June to September	June to September
Mustard Ball	Europe	June to August	July to September
Mustard, Tumbling	Europe	June to September	July to September
Mustard, Wormseed	Native	June to July	June to September
Ox-Eye Daisy	Europe	June to August	June to September
Purslane	Europe	May to October	June to October
Penny Cress	Europe	June to September	June to September

Characteristics	Duration	Place of Growth	Method of Control and Destruction
Erect, coarse herb	Perennial	Field and meadow	Frequent fall cultivation
Tall erect with long leaves	Annual	Cultivated lands	All weeds about the fences or on fire guards should be mowed when first showing blossom, and watched afterwards to prevent their forming seed
Erect, hairy, coarse, herbs; flowers reddish purple; seed a round burr, flat on one side	Biennial	Waste ground and pastures	A bad pest where sheep are kept. Cut below the crown
Erect, branching	Annual	Everywhere in good soil	Easily destroyed by harrowing, hoeing or horse-weeder
Erect, branching, flowers, showy, yellow	Annual	Everywhere	Hand-pulling and burning. Frequent cultivation of stubble fields after harvest. Never let a plant go to seed
Erect, slender, branching towards the top, flowers, orange	Annual	Cultivated lands	Summer fallowing followed by a hoe crop will clean badly infested land. In grain fields the use of the horse weeder as early as possible in spring is effective
Erect, branched; when ripe the head breaks off and is blown long distances, thus distributing the seed	Annual	Cultivated lands	These mustards are dangerous weeds. Since their introduction they have spread with marvelous rapidity, and strenuous effort must be made to keep them in check
Erect, branching, flowers yellow	Annual	Everywhere	Cultivation after harvest and follow with hoed crop. Hand-pull before seeds form in fence-corners, etc.
Erect, branched; flower white with yellow eye, large and showy	Perennial	Pastures, hay fields, and waste places	Mowing infested fields early in June is recommended. Ordinary cultivation will destroy it in tilled land
Prostrate, creeping, leaves and stem fleshy	Annual	Gardens mostly	Frequent cultivation in fields and eternal hoeing in gardens
Erect, branched towards the top	Annual	Grain fields	Mowing the patches and burning the plants are the most effective remedies

Name	Origin	Time of Flowering	Time of Seeding
Pigweed Red-root	Tropical America	July to September	August to October
Plantain (Several species)	Europe	June to September	June to September
Ragweed	Native	July to September	August to November
Russian Thistle	Russia	July to September	August to November
Sow Thistle	Europe	June to August	July to September
Sorrel	Europe	June to October	June to October
Shepherd's Purse	Europe	May to November	June to November
Wild Oat	Native	July	July to August
Wild Lettuce	Europe	June to September	July to October

Characteristics	Duration	Place of Growth	Method of Control and Destruction
Erected, branched	Annual	Rich fields and gardens	Frequent fall cultivation, plowing infested fields after harvest, before seed ripens
Leaves prostrate; flower stem erect	Perennial	Everywhere	Burn or mow stubbles, immediately after harvest. Keep hoe crops cultivated as late as possible; cut by spud in lawns
Erect, branching	Annual	Everywhere	Keep cultivated as late as possible; mow
Spreading, much branched	Annual	Cultivated lands	One of the most injurious of weeds. Never let a plant go to seed. Hoed crops and constant use of the horse-weeder in grain as long as possible, then hand-pull
Erect, stem leafy	Annual and Perennial	Fields and waste places	Cultivate immediately after harvest, and follow with hoed crop
Stem erect, from running root-stocks	Perennial	Everywhere, but chiefly in sour poor soils	Application of lime to infested land and frequent cultivation will eradicate the weed
Erect, slender, seeds, triangular capsules	Annual	Everywhere	A bad weed in the Northwest. Hoed crops, horse-weeder on grain
Like tame oats except as to sucker nose on grain	Annual	Everywhere	On infested fields grow hoed crops or fallow
Erect, branching	Annual	Everywhere	Hoed crops. Use horse-weeder on grain crops as long as possible

BOOK IX
INSECT PESTS AND PLANT DISEASES

PART I. INSECT PESTS

CHAPTER I.

THE INSECT DANGER AND GENERAL MEANS OF CONTROL

I. INSECT INJURY TO CROPS. II. RESULTS FROM INSECT CONTROL. III. VALUE OF THE KNOWLEDGE OF INSECTS. IV. NATURAL ENEMIES OF INSECTS. V. FARM METHODS OF CONTROL. VI. INSECTICIDES POISONS—CONTACT INSECTICIDES—FUMIGANTS—REPELLENTS.

INSECT INJURY TO CROPS

A few statistics regarding the damage done to American crops and American timber by insects will serve to show the seriousness of their depredations. An epidemic of cutworms upon the corn in a limited area of Indiana caused in a single season a loss of \$200,000. A single season's loss in Kentucky from the flea beetle's attack upon tobacco was \$2,000,000; while the annual price of the boll weevil is computed at \$20,000,000. Fruit trees pay \$30,000,000 toll each year and the total forest loss throughout the United States amounts to \$100,000,000. While the annual insect damage to most crops is calculated at 10 per cent of their value, truck crops suffer much more heavily; their loss is counted at twenty per cent and amounts to \$60,000,000 a year. The national loss in wheat from the attack of the Hessian fly for the year 1900 was estimated by the United States Department of Agriculture at \$100,000,000. C. L. Marlatt, Assistant Chief of the Bureau of Entomology, United States Department of Agriculture says: "In no country in the world do insects impose a heavier tax on farm products than in the United States. The losses resulting from the depredations of insects on all the plant products of the soil both in their growing and in their stored state, together with those on live stock, exceed the entire expenditures of the National Government, including the pension roll and the maintenance of the army and the navy."

Results from Insect Control—Enormous as these figures are, they would undoubtedly be much worse if no effort were made to control the ravages of these pests. The prevention of loss from the Hessian fly brought about through the knowledge of proper seasons for planting wheat, etc., has amounted to from \$100,000,000 to \$200,000,000 annually. Arsenical sprays have limited the damage of the codling moth to two-thirds of its former magnitude. The Colorado potato beetle once thought to be a devastating plague from which there was no hope of escape, is now through the general use of Paris green, but little feared by the

farmer. Rotation of corn with oats or other crops saves the corn crop from attacks of the root-worm to the extent of perhaps \$100,000,000 a year.

Value of the Knowledge of Insects— So the farmer is by no means helpless in the grasp of an uncontrollable enemy. He can combat insects successfully if he has the necessary knowledge and is willing to take the trouble and keep at it long enough. He must be able to identify the different harmful species when they make their appearance. Insects multiply with such rapidity that the loss of a few days' time in getting at them may mean thousands to kill instead of tens. A brief knowledge of their life history is also quite as important. The innocent looking butterfly may be laying eggs that will hatch hundreds of hungry little caterpillars. The undisturbed rubbish heap may be offering an excellent shelter for numerous pests during the long cold winter. Prevention is always better than cure. The farmer who is armed with a real knowledge of the characteristics and habits of the most common pests has very little to fear from them.

Natural Enemies of Insects— Nature has her own forces that make war upon the insects. Among the most efficient are the swallows, chickadees, cuckoos, kingbirds, catbirds, robins, bluebirds, and woodpeckers. These birds depend upon insects almost entirely for their food. Where poultry is raised under the colony system of housing and allowed to range over a large area, the insects will be practically cleaned out and the fowls have done much toward their own support. The insect world itself has several species which devote their lives to eating other insects and horrid as this practice may seem it is of great value in crop production. The ladybird beetles are splendid little allies for the farmer and deserve his respect. Tachina and syrphus flies are parasites living upon other insects and slaying their thousands every year.

Farm Methods of Control— Many farm practices valuable in keeping the soil fertile also aid greatly in doing away with insects. For instance some species of insects attack only one kind of plant, such as corn, strawberries or onions. The first year that this crop is grown the damage done by these insects will be slight, probably passing unnoticed. If the same crop is planted the following year the pest which has weathered the winter safely in the ground or in nearby weeds or rubbish, is greatly increased in numbers and ready to do real injury to the crop. The farmer who is forewarned does not plant this field to the same crop the following year; he practices a rotation and the insects deprived of their natural food starve to death. Deep fall ploughing turns up many a grub prepared to spend a safe winter in the soil and leaves it to the mercy of the frost. Weeds and rubbish are not only unsightly, they are winter resorts for many of the farmer's most baleful enemies. Cleaning them up and burning them is like surprising the stronghold of a sleeping army.

Insecticides—The use of the various poisons and insecticides depends upon a knowledge of the insects' feeding habits: 1. If the pest eats leaves and tissues, that is, if it really has a mouth which can bite, it can be killed by applying a **poison** that will be taken into the mouth, such as Paris green or lead arsenate. 2. If on the other hand the insect lives from sucking the juices of plants, its beak will be inserted directly into the interior of the leaf and miss the poison on the surface entirely. For such pests the "**contact**" insecticides must be applied. These generally enter the breathing system causing suffocation or harden and dry up the skin. 3. For insects that live in stored produce, such as grain weevils, **fumigants** are generally used. These are gasses which suffocate the insects and must be used in air-tight bins or sacks. 4. **Repellents** are different substances such as tobacco dust and air-slaked lime which are so offensive to the insect that it will avoid them.

POISONS FOR BITING INSECTS

Paris Green is a bright green powder, one of the combinations of arsenic. It is a deadly poison. It may be applied dry if mixed with three or four times its weight in flour or fine air-slaked lime, but it is more generally used in solution.

Paris Green Solution.

Paris Green.....	5 ounces
Slaked Lime.....	1 pound
Water	50 gallons

Mix the Paris green first in a small vessel with a small quantity of water.

Two or three pounds of resin soap may be added to make the spray stick better to plants with smooth surfaces such as cabbage.

Arsenate of Lead may be obtained as a powder or a paste. The latter is the more common form but the two do not differ as to their chemical properties. It is not so violent a poison as Paris green, and for this reason is not so liable to burn the foliage. It is frequently used in the powdered form dusted upon the leaves of garden and truck plants to which it sticks very well. The solution is prepared by the following rule:

Arsenate of Lead Solution.

Arsenate of lead paste.....	3 to 10 pounds
Water	50 gallons

Hellebore is a poison which has the advantage of losing its poisonous properties after a few days and may be applied safely to ripening fruits. It may be used dry or as a spray. When sprinkled dry it should be mixed with three times its weight in flour.

Hellebore Solution

Hellebore	1 ounce
Water	1 gallon

Poison bran mash is a mixture of Paris green, bran and sweetened water, and is effective in fighting grasshoppers and cutworms.

Poison Bran Mash

Bran25 pounds
Paris Green	$\frac{1}{2}$ pound
Molasses1 quart
Water2 gallons

Mix the bran and Paris green dry. Pour the molasses into the water and wet the bran with the mixture. Stir until thoroughly mixed. The mash should be scattered on the surface of the ground among the infested plants. For a flavored bran mash especially for grasshoppers see the control of that insect, Chapter II.

CONTACT INSECTICIDES FOR SUCKING INSECTS

Kerosene emulsion is one of the simplest and most effective remedies for plant lice. Made stronger and in large quantities it can be used successfully against insects hibernating in rubbish piles. It cannot harm plant tissues and for plant lice should be applied as a fine spray.

Kerosene Emulsion

Hard Soap	$\frac{1}{2}$ pound
Hot Water (soft)1 gallon
Kerosene (coal oil)2 gallons

Shave the soap in the gallon of boiling hot water and when dissolved remove from the fire and add the kerosene. Churn violently with a force or bucket pump until a smooth creamy emulsion is formed. If made properly no oil will separate. The mixture can be kept indefinitely if sealed from the air. It should be diluted with 10 to 15 parts of water for plant lice; for San José scale with about 3 or 4 parts of water.

Whale oil or common laundry soap is effective against plant lice in the following solution.

Hard Soap1 pound
Water5 gallons

Tobacco dust may be used against root infesting aphides, by applying a liberal dressing of the dust directly upon the roots and then filling in the dirt. Tobacco extract may be prepared as a spray by boiling one pound of dust and stems in a gallon of water. Dilute for use with one or two parts of water. It is quite harmless to plants. Commercial brands of tobacco extract may be bought and are very effective.

Lime sulphur is a chemical combination of lime and sulphur and is valuable both as a remedy against insects and fungous diseases. It is the standard remedy for San José scale. The commercial article can be bought as cheaply as a solution can be made on the farm. It is diluted for different purposes according to directions upon the container. If large quantities are to be used and it is desired to make at home, the

following formula quoted from the New York Experiment Station can be followed:

Concentrated Lime Sulphur Solution

Lime, Pure	36 pounds
If 95 per cent pure.....	38 pounds
If 90 per cent pure.....	40 pounds
Sulphur, high grade finely divided.....	80 pounds
Water	50 gallons

Shake the lime in 10 gallons of hot water adding the lumps gradually to avoid too violent boiling. The sulphur must be thoroughly moistened and made into a smooth paste without lumps. Pour sulphur paste in gradually while lime is slaking, stirring constantly. When slaking is finished, add full amount of water and boil gently for one hour. More than the required amount of water may be added at first if the kettles will hold it, if not, water must be added from time to time to make up for evaporation and keep the liquid at the same level throughout the boiling. This solution will keep perfectly if sealed from contact with the air.

FUMIGANTS

Fumigation is used for killing insects in enclosed spaces. Carbon bisulphide is probably the most common fumigant although sulphur, tobacco, and hydrocyanic acid gas are sometimes used. Sulphur very often injures the germinating power of the grain and is to be avoided for this reason; hydrocyanic gas is a very dangerous and deadly poison. It should never be used except by an expert.

Carbon Bisulphide

Carbon bisulphide, 1 pound to each 100 cubic feet.

The dose should be increased if the temperature is below 60° Fahrenheit. Place the material in an air-tight box, barrel or bin. Pour the carbon bisulphide into shallow dishes and set on top of the material, close the box, cover with canvas or old blankets and leave it for twenty-four hours. When the bin is opened, stir the grain to allow the gas to pass off. **Do not allow a fire, light, or a burning cigar to come anywhere near the carbon bisulphide or the recently fumigated material.**

REPELLENTS

Tobacco dust, air-slaked lime or even fine road dust, coated thickly, will keep away various insects such as the flea-beetle or other leaf eaters.

Tree tangle foot is a sticky substance of the same nature as flypaper. Banded around trees it prevents the ascent of caterpillars.

Bordeaux mixture though strictly speaking a remedy for plant diseases is effective in driving away certain insects particularly those attacking potatoes and tomatoes. It is also a very common practice to

combine the mixture with an insect poison and thus strike at two evils at the same time.

Bordeaux Mixture

Copper Sulphate	4 pounds
Lump Lime	4 pounds
Water	50 gallons

Place 25 gallons of water in a barrel and suspend the 4 pounds of copper sulphate in a bag just below the surface and allow it to dissolve completely. In another barrel slake 4 pounds of lime adding water until the 25 gallons have been used. Combine the copper solution and the lime by dipping alternately from each into the spray tank. Bordeaux mixture should be used as soon as made.

When it is desired to use an insecticide also, arsenate of lead should be added either to the mixture or to the lime in preparation.

A ready-prepared Bordeaux mixture containing arsenate of lead can be bought.



PLATE 22

The White Grub; the beetle, egg, larva and pupa;
enlarged two and one-half diameters.

CHAPTER II.

INSECTS WHICH INJURE GRAIN AND GRASS CROPS.

- I. WHITE GRUBS. II. WIREWORMS. III. CUTWORMS. IV. THE ARMY WORM.
V. THE FALL ARMY WORM. VI. THE CHINCH-BUG. VII. GRASSHOPPERS AND
LOCUSTS. VIII. THE HESSIAN FLY. IX. THE WHEAT JOINT-WORM. X. THE
ENGLISH GRAIN-LOUSE.

WHITE GRUBS

White Grubs (Plate 22) are found normally in grass-lands, but sometimes become so numerous that they invade forage and garden crops, and occasionally attack grain and nursery plantings, especially conifers. Corn, garden crops and strawberry beds are most commonly attacked. The grubs feed upon the roots of these plants, sometimes killing them. They are easily recognized from their large size and the fact that they curl up in a horse-shoe shape. The body is white with a dark brown head, and the end of the abdomen is very much enlarged and dark in color. There are a number of species which are quite similar in the grub stage. The adults are known as May-beetles or June-bugs. These large clumsy beetles are attracted to lights in the late spring, and often enter houses at this time.

Life History— During June the beetles lay their eggs in the soil preferably grass lands. In about two weeks the eggs hatch, and the young grubs feed upon the roots of the plants in the soil. They grow slowly, requiring two years or more before they reach full growth. At the end of the first summer, they burrow down into the ground reaching the distance of about one foot by the first hard freeze. During the second year more damage is done, and crops such as strawberries or corn are very seriously injured. This is especially true if the field where the crop is planted was in grass during the previous year. In about two or in some cases three years, the grub burrows down into the soil and changes to a pupa. This occurs during June or July, and about three weeks later the pupa changes into the adult beetle, the beetle remaining in the soil through the winter. When the beetle emerges in the spring, it feeds in the night on the foliage of trees, hiding in the soil during the daytime. Some of the species prefer the poplar, others maple, others willow, each species having its favorite tree.

Control— Frequent rotation of crops will prevent the multiplication of these beetles. Grass land should be followed by some crop not attacked by the grubs, such as buckwheat, clover, alfalfa or small grains.

Plowing or deep harrowing in early spring and late fall will expose and crush many of the grubs and newly developed beetles. Pigs will root out and eat many of the grubs. In some regions the beetles are shaken from the trees at night into receptacles placed beneath and then collected and destroyed. As these are attracted easily to lights, lanterns may be placed over large pans or tubs of water covered with a thin film of oil, these being placed near the trees. Do not leave land to sod for a number of years in succession.

For more detailed information see the United States Farmers' Bulletin No. 543.

WIREWORMS

Wireworms (Fig. 2, Plate 23) are so named because of their appearance; they are long, hard and shiny, looking like short pieces of wire about three-fourths to one inch in length. They live in the soil, burrowing into the seed of corn and occasionally wheat and other grains, often making it necessary to replant the crop. They also burrow into potatoes and turnips and other garden crops. These worms are the grubs of a long brownish beetle usually known as the click beetle because of its habit, when turned on its back, of throwing itself into the air with a sharp clicking sound, turning over and landing on its feet. There are several different species of the wireworm. They are all very similar in appearance.

Life History—The life history of the wireworm resembles closely that of the white grub, except it usually requires three to five years to complete the cycle. Old grass lands are the favorite feeding places, and crops planted on land that has been in grass are more apt to be injured by the wireworms the second year after planting. The life histories of none of the species have been worked out in detail, but we know that in midsummer of its last season of growth, a small cell is formed in the soil where the wireworm transforms to a pupa. In three or four weeks the beetle appears but remains in the cell in the ground until the next spring.

Control—Control measures are similar to those suggested for the white grubs. Late summer or early fall plowing followed by thorough harrowing will crush and destroy large numbers of the pupæ and newly formed beetles. Sometimes the wireworms can be trapped over small areas by placing bunches of clover poisoned with Paris green under boards on top of the soil. Rotation of crops should be practiced, not allowing the land to remain in grass for a succession of years.

CUTWORMS

By the term cutworm we mean the caterpillars of several species of moths (Fig. 1) which are very similar in appearance and have the habit

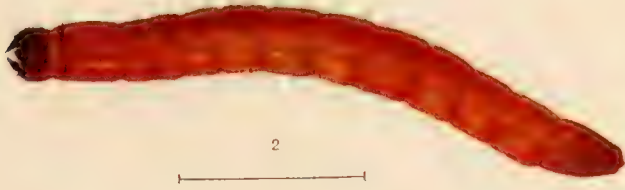

Lydia Moore Hart

PLATE 23

Fig. 1—*Myochrous denticollis*. Fig. 2—THE CORN WIREWORM, *Melanotus cribulosus*
Figs. 3-5.—CLICK BEETLES, adults of other Corn Wireworms; 3 *Drasterius elegans*; 4 *Agriotes
mancus*; 5 *A. pubescens*.

of feeding on low growing vegetation, cutting off the stems just at the surface of the ground. White grubs sometimes have a similar habit but are easily distinguished from cutworms. The adults of the cutworm are medium-sized, dark colored moths often seen about the lights at night, and often called moth millers. When very abundant these cutworms will destroy almost any green, tender growth or roots, and many even move from field to field like army worms. Some species have the habit of climbing trees and cutting off the buds. They are known as climbing cutworms. We usually hear of cutworms as injurious to garden crops, corn, tobacco, cotton and other crops grown in rows or hills. Their damage to small grains or forage crops is usually very small. There are



Fig. 1.—A Larva and the Adults of Six Species of Common Cutworm.

Courtesy of the Minnesota Experiment Station

many species differing slightly in life history but for practical purposes they can be considered as one.

Life History—The female moth deposits her eggs in grass lands where a field has grown up to weeds and grass the latter part of the summer. The eggs are placed on leaves or stems of plants and the little caterpillars as soon as they hatch, which is in August or September, burrow into the soil and feed upon the roots of surrounding plants until frost comes; then burrowing down deeper they form cells in which they hibernate until spring. In spring they will continue to feed upon the same grass or weeds but if some crop is planted upon the field, this will suffer. They will also frequently move from their hibernating places to

cultivated land close by, where they can feed upon the growing crops. By next spring or early summer, the cutworms are full grown and are a dull brown, gray or blackish color marked with two long stripes or spots harmonizing with the color of the soil. They are about one and one-half to two inches long, and when disturbed curl themselves up like a watch spring. When full grown they enter the soil and pupate a few inches below the surface, the adults appearing about four weeks later, sometime in July. There is but one generation a year in the North, but as we go further South, the generations increase to two and in some cases three each summer. The greatest injury is done in the spring when the plants are young and have just been set out or are just appearing above the ground.

Control — Fall plowing followed by plowing and thorough harrowing in the spring is about the most effective way to combat cutworms. When the land is planted to corn or other crops especially subject to injury by cutworms, plow in the late summer and allow no weeds or grass to grow upon the land during the remainder of the summer and autumn. This will prevent the moths from laying eggs there. A poisoned bran mash is often used and if well applied a few days before plants are set out or a few days after seed is sown, it is very effective. (See Poisons, Chapter 1). In large fields this bran mash can be applied with a corn drill or in gardens with an onion drill, placing it on the surface near the plants. Applied by hand, tablespoonfuls of the mash should be dropped along the rows about two or three feet apart late in the afternoon so that it will still be moist when the worms appear after dark. Be sure to keep poultry away from the field treated in this way. Market gardeners place cylinders of stiff paper or metal such as tomato tins with the two ends cut out, around the stems, sticking them well into the soil. This is useful in connection with such plants as cabbage and tomato as it keeps the cutworms from getting into the stems. As a substitute for the bran mash, clover poisoned with Paris green may be distributed throughout the field.

ARMY WORMS

Throughout the United States east of the Rocky Mountains, there are occasional outbreaks of worms resembling the cutworm, appearing in enormous numbers. They are known to move like armies (hence the name) from field to field devouring everything before them. Then probably they will not again appear for several years. Their appearance is always very sudden and before anything can be done to control them, they have caused an enormous amount of damage. Although they are always present in small numbers in their normal breeding grounds of rank grass, it is only when conditions for their development



PLATE 24

The Army-worm, with pupa, moth, and egg.

are particularly favorable, that they develop in such huge numbers as to form a devastating army. They have many parasites, however, that usually appear at this time and quickly reduce their numbers again.

Life History—The adult moths of the army worm are similar to those of the cutworm (Plate 24). They appear early in June in the northern states and lay their eggs on grass plants near the base of the leaves. Every female lays several hundred eggs so that their increase is very rapid. Young caterpillars appear in about ten days and begin feeding. They devour corn, wheat and closely related grains, attacking the leaves and stems and generally cutting off the heads. They may, however, feed on many garden crops. Feeding is usually done at night and during cloudy days. In three or four weeks, the worms are full grown and about one and one-half or two inches long. They are dark gray or dingy black in color with three narrow yellowish stripes down the back and a slightly broader and darker one on each side. About the middle of July they enter the soil and transform into pupæ. The adult moths appear in about fourteen days and lay the eggs for the second generation of worms. This second generation appears in September but is rarely injurious. The winter is spent either as moths or partly grown worms in the ground. The next spring young army worms complete their growth without doing much damage, pupate in May, and the moths of the first generation appear in June. In the North, we have usually three generations in a season, but further south there may be as many as six.

The army worms have many natural enemies. Their parasitic and predaceous insects hold them in check so effectively that we usually have only a single outbreak in a year, the later generations of that season being often almost completely destroyed. Among these enemies are the ground-beetles and better still, the tachina flies. These flies, which in appearance and size closely resemble house flies, place their eggs upon the army worms and the maggots later work their way into the body, feeding upon the internal organs and fluids until the worms are killed. When their numbers are small and they feed only at night, the flies cannot get at them readily, but when the worms become so numerous as to feed by day, the tachina flies are very active in subduing them. Their eggs can be seen as little white spots on the worms usually just behind the head. A single fly may place fifty or sixty of these eggs on one worm. Army worms with tachina flies' eggs should not be destroyed for by so doing we are destroying enemies far more effective than ourselves in killing the army worm.

Control—When army worms are discovered they should be kept from the crops by the use of barriers. A dust furrow such as is usually used in the control of chinch bugs will serve. When the soil is damp

it may be necessary to make two or three furrows in order to keep out the approaching army. When the furrows become full of the worms they can be destroyed by spraying them with kerosene. Burning all grass along ditches, fences and lands where these army worms live normally is an effective preventive; also deep plowing and thorough harrowing where possible, will kill many which are hibernating.

A bran mash (see Chapter 1) may be used in a manner similar to the one described for cutworms; or Paris green or arsenate of lead may be sprayed over a narrow strip of ground toward which the worms are approaching.

The Fall Army Worm—The fall army worm is very similar in habits to the true army worm but appears later in the season. It feeds upon a large number of crops, but seems to have no preference for grass or grain, attacking as readily sugar beets, cowpeas, sweet peas and other forage and truck crops. It is sometimes called the alfalfa worm because of its attack upon that crop. The caterpillar may be distinguished from the army worm by the following characters: a longitudinal stripe extends along each side of the body, a wide yellowish stripe extends down the middle, and in this stripe on each segment are four black dots. The armies of these worms are also less compact than those of the true army worm.

Life History—The moths appear in the spring, placing their eggs upon grass and covering them over with grayish hairs from their own bodies. The young caterpillars appear during May and June and although we do not know the entire life history, in the North there are probably two generations. In the latitude of southern Illinois there are three and in the extreme South about four generations each season. They hibernate as pupæ in the soil.

Control—The pupal cells in the soil will be broken up and crushed by deep plowing and thorough harrowing. Disking such crops as alfalfa will accomplish the same result and badly infested lawns may be raked deep with a long-tooth rake. In fields of young grains or on lawns, rolling with the heavy roller will destroy many of them. Poison bran mash may be used, or the crop may be sprayed with arsenate of lead or Paris green. If they are moving as an army, the same methods as recommended for controlling the army worm may be used.

THE CHINCH-BUG

The chinch-bug (Plate 25) is almost too well known to need description. It is found over the greater part of the United States from the eastern coast to the Rocky Mountains. It is a small insect, being only one-fifth of an inch long. The body is black with white wings, each wing being marked with a small black triangle on the outer margin. There are two forms, the long-winged form and the short-



PLATE 25

The Chinch-bug; five stages of development and the egg.

winged form. The short-winged form is found along the Atlantic Coast and southern shore of the Great Lakes. Of these short-winged forms, the wings are only about one-half as long as the abdomen and the bugs are incapable of flying. Over the rest of their habitat the long-winged form prevails. The greatest injury done by the chinch-bug is to corn and small grains. They have caused more loss to these crops probably than any other insect which attacks them. The total injury caused from 1850 to 1909 has been estimated at \$350,000,000.

Life History—The winter is spent by the adult bugs in hibernation



Fig. 2.—Corn Plant Infested by Chinch-Bugs.

Courtesy of John Wiley & Sons

at the base of clumps of grass, in a shock of corn or under any rubbish which may be left in the field. The next spring they come out and seek places suitable to feed. The female begins to lay her eggs, depositing them on the roots or near the base of stalks of grass. From the middle of April until the first of June, one female may lay from 100 to 175 eggs. These eggs hatch in two or three weeks and the nymphs are full grown about harvest time. As soon as the wheat is harvested, they migrate to oats and then to the corn. The adults of this first generation lay their eggs upon the unfolding ears of corn and the second

brood of nymphs appear in about ten days. This second generation matures in August or September, and it is these chinch-bugs which hibernate over the winter. Where corn is not available for the second generation, they will feed upon grass.

Control—The chinch-bug may be destroyed by burning over grass lands and waste areas, such as along fences and roads and hedges in woodlands, as soon as it has become dry enough in the fall and early winter; thus the bugs are destroyed after they come to hibernate. All crop remains such as corn stalks, should be removed from the field and the butts either plowed under deeply or raked up and burned. The chinch-bug can also be attacked as it migrates from grain to corn or from field to field. Furrows may be plowed along the side of the field from which the invasion is expected. They should then be harrowed thoroughly so as to produce a fine dust, and a dead furrow plowed through the middle. If a log is dragged through this furrow making the sides as steep as possible, the bugs will fall into the furrows and will be unable to crawl out. The heat of the soil will often kill them in the bottom of this trench, or pits can be dug at short intervals into which they will fall. A strip of coal tar poured into the bottom of the furrow is very effective. This line of tar may also be poured directly upon the ground which should be previously cleared of vegetation by a scraper; it can be about the width of a man's finger and can be poured from a watering can. Sometimes it is run in zig-zag fashion with the pits at the inner angles so that the bugs will be collected at these points and forced into the holes. When the tar becomes hardened and covered with dust, the chinch-bugs will be able to crawl over it, and it must then be renewed. It has been estimated that the cost of keeping such tar strips in good condition is only about \$2.00 a mile for one month. Some of the heavier road oils are now used in place of the tar, as they do not become hard quite so quickly.

GRASSHOPPERS AND LOCUSTS

No other insect is so widely known as the grasshopper or locust which has destroyed crops in every country the world over. Every one remembers the Rocky Mountain locusts which were so destructive in the Middle West a generation ago. With settlement and cultivation of land, these migratory locusts have disappeared and today the Rocky Mountain locust cannot be found in America. But grasshoppers or non-migrating locusts appear in many parts of the country from time to time in large numbers, causing immense losses to the farmer. They are especially apt to appear in these large numbers after a succession of very dry years, years in which it is impossible for their natural enemies, bacteria and fungi, to develop abundantly. After the recurrence of these growths it requires two or three years to get the grasshoppers in check once more. There are several species of grass-

hoppers which are destructive but they can be considered as one from the economic standpoint.

Life History—The female grasshoppers begin to lay their eggs in the middle of August, continuing until frost appears. They prefer, for egg-laying, places where the ground is dry and fairly compact, many of them using the land where they have been feeding. Most of the eggs, however, are laid along roadways, fences and land which has not been under cultivation but has grown up to grass and weeds. The eggs are placed from one inch to one and one-half inch below the surface in pod-like or boot-shaped cavities, in which they are cemented together so that they can be removed from the soil intact. The eggs remain in the soil over winter and hatch from the middle of May to the first of June. The pods of eggs have been so placed in the soil that the young nymphs are easily able to work their way upward to

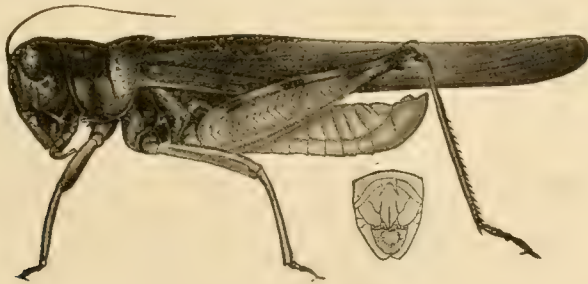

Fig. 3.—Rocky Mountain Locust.

Courtesy of the Minnesota Experiment Station

the surface. These young nymphs resemble the adults very closely except that they have no wings. They begin feeding very soon and if food is present in sufficient quantities, remain near their birthplace until after one or two sheddings of their skin.

They feed only during the warm bright part of the day. During damp, cold weather and at night they hide away in rubbish or clumps of grass. If food becomes scarce or more attractive food is at hand, they may mass together and move away in a body. When very abundant every green thing may be devoured, first grasses and grain and then foliage, shrubbery and trees. If nothing else remains, they have been known to gnaw bark of timber and even wooden fences and buildings.

In July and August these nymphs shed their skin for the last time and appear as full grown grasshoppers with wings. They are now ready to lay eggs for the next season's generation.

Grasshoppers have a large number of enemies. Most birds are found feeding upon them, even those which are normally seed eaters will rear their young upon the soft bodies of the grasshoppers. Many insects such as the tachina flies prey upon the young grasshoppers. A small

red mite appears early in the spring and destroys many of the eggs. The larvæ of our common blister beetles also destroy many of the eggs. The fungous and bacteria diseases already mentioned destroy a large number during damp humid weather.

Control—Control measures may be carried out upon the eggs of the hoppers. Fall plowing, if done deeply enough, probably destroys many of the egg pods by crushing them and exposing them to drying

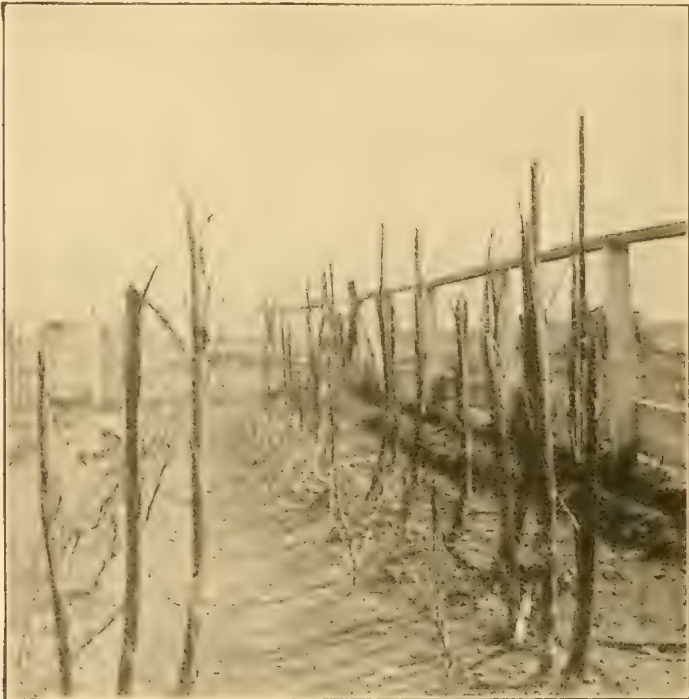

Fig. 4.—Damage Done to Corn and Beans by Grasshoppers.

out and to their natural enemies. A scheme has recently been developed for destroying the hoppers by poisoning them with flavored bran mash. This bran mash is prepared in the following way:

Bran	20 pounds
Paris Green	1 pound
Syrup	2 quarts
Three Oranges or Lemons.	
Water	3½ gallons

Mix the bran and Paris green dry; add the syrup, the juice and grated rind of the lemons or oranges to the water; then wet the bran with this mixture, stirring until all the bran is thoroughly moistened. This formula is sufficient to cover 5 acres and should be spread in fine particles early in the morning. The grasshoppers prefer this to their green food and in the course of a couple of days a great majority will perish.

Where the young hoppers have migrated in large numbers to such places as on the edge of fields, along roadways or in weedy lands, they may be destroyed by spraying them with kerosene emulsion or with a strong arsenical spray. This is particularly useful in the early spring before the young hoppers have been able to migrate from their hatching places to cultivated fields. It does not seem practicable to spray growing crops, but if used in places mentioned it will in many cases destroy young hoppers before they enter the crops.

The hopper-dozer has been used very successfully for a long time



Fig. 5.—Damage Done to Cabbage from Grasshoppers.

in combating grasshoppers. The hopper-dozer consists of a shallow pan mounted on runners. It is usually about twenty inches wide and four inches deep. The length can be arranged to suit the convenience of the farmer. Behind the pan is erected a screen consisting of a framework of gas piping or other light material about three feet high. Over this is stretched canvas or sheeting. The pan is filled one-half full of water with a film of kerosene poured on top. It is also well to have the canvas soaked with kerosene. The hopper-dozer is drawn through the field by a horse, the young hoppers jump up in front of the hopper-dozer and into the pan. The screen keeps them from



Hopper-dozer in Action.
Courtesy of Prof. F. L. Washburn, Minnesota State Entomologist

hopping over. One or two partitions in the pan will help to prevent slopping. The hopper-dozer is not safe to use if the grain has become taller than seven or eight inches, for it will be broken down by the machine passing over it.

THE HESSIAN FLY

Perhaps the most destructive insect attacking wheat is the Hessian fly. Barley and rye are occasionally attacked but wheat seems to be the main food plant of this insect. The Hessian fly has been in America for many years. Its first appearance was in Long Island about the year of 1779, at a place near where Hessian troops had landed during the Revolutionary War. This fact gives it the name of Hessian fly.

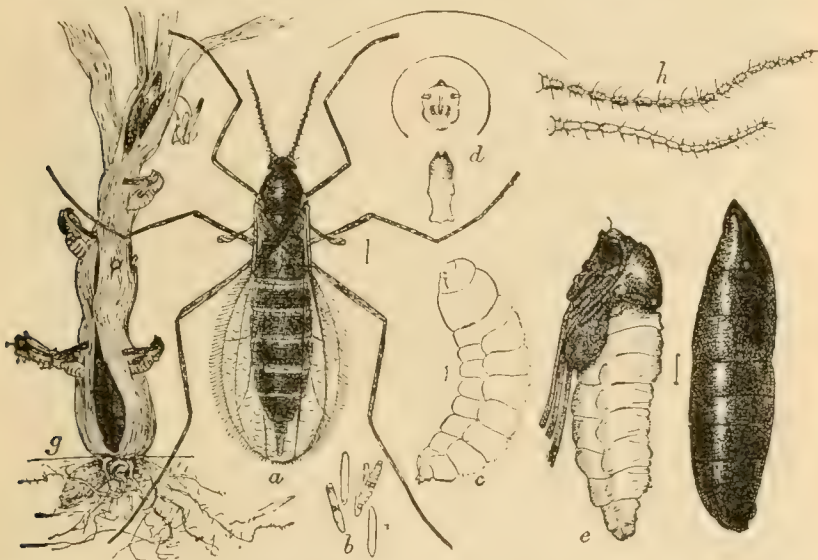

Fig. 6.—The Hessian Fly. A—Female Fly; b—flaxseed stage or pupa; c—larva; d—head; e—pupa; f—puparium; g—infested wheat stem showing emergence of pupae and adults.

Courtesy of John Wiley & Sons

It has invaded practically the entire wheat growing area of the United States, between the parallels of 25 and 35 degrees and is also present in Canada. We estimate that at least 10 per cent of the wheat crops in the country is destroyed every year by this pest. Occasionally the loss goes as high as 25 and 50 per cent during seasons when it is especially numerous. The Hessian fly is a very small, dark colored gnat, not more than one-tenth of an inch in length; it is so small that it escapes observation except upon very close examination.

Life History—The female fly produces about 125 small reddish colored eggs, which are placed usually on the upper surface of the leaf in irregular rows. The small maggots which hatch from these eggs

are about twice as long as they are broad and lack both head and legs. The fall generation of maggots goes down between the sheaf of the leaf and the stem, causing a small enlargement at the point of the attack. They live by sucking the juice of the plant and thus prevent proper growth and nourishment. The presence of the Hessian fly maggots in winter wheat in the fall causes the plants to stool out so

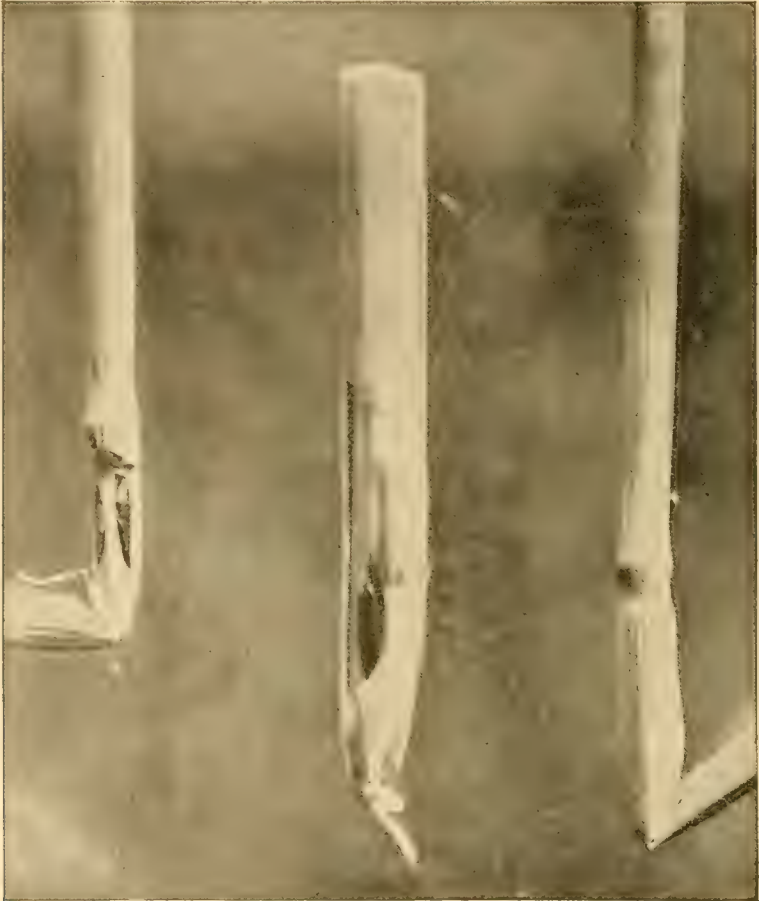

Fig. 7.—“Flaxseed” or Hessian Fly in Wheat Stems.

Courtesy of the Minnesota Experiment Station

that no center stems are produced. At first the leaves are darker colored but later they turn yellow and die. In springtime the maggots attack the lateral branches or tillers and weaken them so the stems break off and fall to the ground. It requires about four weeks for the maggot to reach full growth; its skin then contracts, shrivels, turns dark brown and hard, forming a cover inside of which the maggot transforms to the pupa. The outside case is called the puparium or

in common terms the flaxseed stage (Fig. 7). These flaxseeds will be found tucked away in the base of the leaves of plants. Winter is passed in the flaxseed stage, and the flies emerge in April or May to lay eggs for the summer brood, which remains in the flaxseed stage in the stubble of the wheat until fall. Then the adult flies appear again about the time the winter wheat is being planted. Where winter wheat is not grown, the flies will place their eggs upon volunteer wheat and this will serve to care for them all the winter. The eggs of this second generation hatch and the maggots become full grown and transform to the flaxseed stage before the cold weather.

Control—In winter wheat regions it is possible to avoid the attack of the Hessian fly by planting later than is usually done. The adult fly lives only about a week and then dies, so if planting is postponed until after that time there will be no danger of her placing her eggs upon the young plants. The exact time of appearance of the flies is variable, as atmospheric conditions such as dry weather, and late summer and early fall will delay their appearance. The farther south we go, the later they appear.

Professor F. M. Webster, of the United States Bureau of Entomology, has given us the following dates which will probably be found safe for sowing wheat in normal seasons: in northern Michigan, soon after the first of September; south Michigan and north Iowa, about September 20; in south Iowa, the second week in October; in Kentucky and Tennessee, October 20.

As volunteer plants are a means of carrying over the fall generation until the next spring, it would be well to destroy all volunteer wheat, by plowing in before cold weather has come. A strip of wheat can even be planted to be used as a trap crop. The flies will be attracted to this and place their eggs upon the plants, after which it can be plowed in and the eggs and maggots destroyed. As soon as this is done the main crop can be planted with safety. Rotation of crops would help some in checking the Hessian fly as it would compel the adult fly to travel widely in search of young plants in the fall. As the flies from the first generation remain in the stubble after harvest, most of them will be destroyed if it is possible to burn over the fields at this time. To aid in this the grain could be cut rather high at harvest and the grass and weeds can be mowed and allowed to dry for a few days before burning over.

Anything which will produce more vigorous plants such as preparation of a good seed-bed, use of fertilizers, etc., will help the plant to overcome the ravages of the fly and produce a crop in spite of its presence. Varieties of wheat with long, coarse, strong straw are said to be less liable to injury than weak stemmed, slow growing varieties, although none are entirely free from attack. After the flies are once

present in the crop, there are no remedial measures which will destroy them.

Professor Webster, our best authority in America, says: "After thirteen years of study of the Hessian fly, I am satisfied that four-fifths of its injuries may be prevented by a better system of agriculture. For years I have seen wheat grown on one side of a division fence without the loss of a bushel by attack from this pest, while on the other side the crop was invariably always more or less injured. No effect of climate, weather conditions or natural enemies could have brought about such a contrast of results. The whole secret was in the management of the soil and the seeding."

THE WHEAT JOINT-WORM

The wheat joint-worm is found in the wheat-growing regions of the United States, east of the Mississippi River. The adult is a small four-winged fly about one-eighth of an inch in length, black in color with the legs and feet yellow. The injury is done in the maggot stage. The maggots eat little cavities in the straw, often producing knots and swelling in the joints attacked. This cuts off the supply of sap, preventing the head of the wheat from developing fully, even the kernels that so develop are small and shriveled. The stem also becomes brittle and woody at the point of attack and winds are apt to break down the plants. The adult flies appear from April to June, placing their eggs upon the stems of wheat, usually selecting the uppermost joints that have appeared. The presence of this insect can be detected by the short, hard bits of straw containing the larvæ which will be carried out with the grain from the threshing machine instead of going over into the straw. The larvæ contained in these parts of straw are probably all killed in threshing. The injury done by this insect varies considerably, sometimes its presence is hardly noticeable and other times almost the entire crop may be destroyed.

Control — Rotation of crops is very important in the control of this pest. Wheat should be planted as far as possible from the land which was under seed the previous year. Burn over the stubble during the late fall or winter or plow it under if possible. Cut the grain as low as possible so as to leave the larvæ in the straw. They will then be destroyed at threshing time. Fertilize as soon as possible and prepare the seed-bed carefully so as to give as vigorous growth to the plant as possible.

THE WHEAT STRAW-WORM

The wheat straw-worm is more injurious west of the Mississippi River than in the East. It may cause very high loss, while at other times its presence may scarcely be noticed. A plant attacked by this

insect will produce no grain at all. There are two generations of the insects, those of the first having considerable difference in appearance from those of the second generation. They are minute, shiny, black insects, with or without wings and with the legs more or less banded with yellow. These insects appear in the straw and stubble early in April and the females deposit their eggs on the young wheat plants just below the embryonic wheat head. The larvæ when hatched work within the stem, and can be found in the crown of the plant by the time it has become full grown. The grub has entirely eaten out the head of the plant and its body occupies the cavity thus formed.

Control—The adult insects of the first generation usually have no wings so if wheat is planted far from the field where it was planted the year before the flies will not be able to get to it. If it is possible to keep the land free from wheat for two years, this is the most practical method of control. Burning over the stubble and straw is also a help.

THE ENGLISH GRAIN LOUSE

This plant louse is probably the most common of the aphides affecting wheat and other small grains. It is a large green aphid that often develops in enormous numbers. They commonly cluster on the different heads of the grain and suck out the sap, interfering with its development. In the North they appear in April, while in the South they remain active during most of the winter. Before the heads begin to form, the aphides will be found on the leaves of the grain. They multiply very rapidly, each female giving birth to from forty to fifty young and these becoming full grown in about ten days, reproduce again in a similar manner. Where so few were present as to be scarcely noticed, in a very few weeks the plants may be swarming with them. Winged forms are produced from time to time during the season and these fly to other plants. After the grain has ripened, they attack various grasses, later coming back to volunteer oats and fall wheat. They are attacked by many enemies both the predaceous insects and fungi. If these enemies for some reason fail to do their work, as will be noticed after a dry season, we have heavy outbreaks of the grain louse.

Control—Rotation of crops, thorough preparation of the seed-bed, and fertilization, combined with destruction of wheat and oats in the fall are practically the only methods which will keep this insect in control.

CHAPTER III

INSECTS INJURIOUS TO CORN.

I. THE CORN-ROOT APHIS. II. THE WESTERN CORN ROOT-WORM. III. THE SEED CORN MAGGOT. IV. BILL-BUGS. V. THE CORN EAR-WORM.

THE CORN-ROOT APHIS

The corn-root aphid (Plate 27) is a tiny plant louse of bluish green color, covered with a whitish bloom, clustering on the roots of corn. These aphides usually cause the corn to become dwarfed and yellow or reddish in color, and to lack general thriftiness. The winged generation has the head and thorax brownish, with several blackish spots on the surface of the abdomen. We find these insects throughout most of the corn-growing regions of America, but they are more abundant where corn has been grown year after year on the same land. Where corn has been planted the second year on infested land, it frequently happens that the entire crop is lost. They feed also on broom corn and sorghum, and upon many weeds such as foxtail grass, crab-grass, purslane, ragweed, smartweed, and many others. Ants play a very important part in the life of the corn-root aphides. They winter over in the egg state and these eggs are guarded by the ants and carefully stored in their nests in the soil, where they may be found in little piles on the floors of the chambers. They are very carefully attended to by the ants; on warm days they are brought up into the warmer surface soil and they are carried down to the deeper chambers during the cold weather. As soon as the young smartweed and foxtail grass appear in May, these aphid eggs begin to hatch and the young ones are immediately carried up by the ants and placed upon the roots of these weeds. Early in May a second generation of the lice is born. Winged forms are present at this time, and as soon as corn has been planted and the young plants are growing, the ants again carry the lice to the roots of these plants. Their attention does not stop here, for they continue the entire summer burrowing around the roots of the corn, forming chambers for them and carrying them from plant to plant. In return for all this care the aphides supply the ants with a sweet sticky secretion called honey dew, produced in a pair of small tubes projecting from their backs. These root aphides reproduce with extreme rapidity; only eight days passing before a young aphid is ready to produce another generation. In September and October male insects are produced for the first time and these mate with the females which lay eggs to carry the pest over the winter.

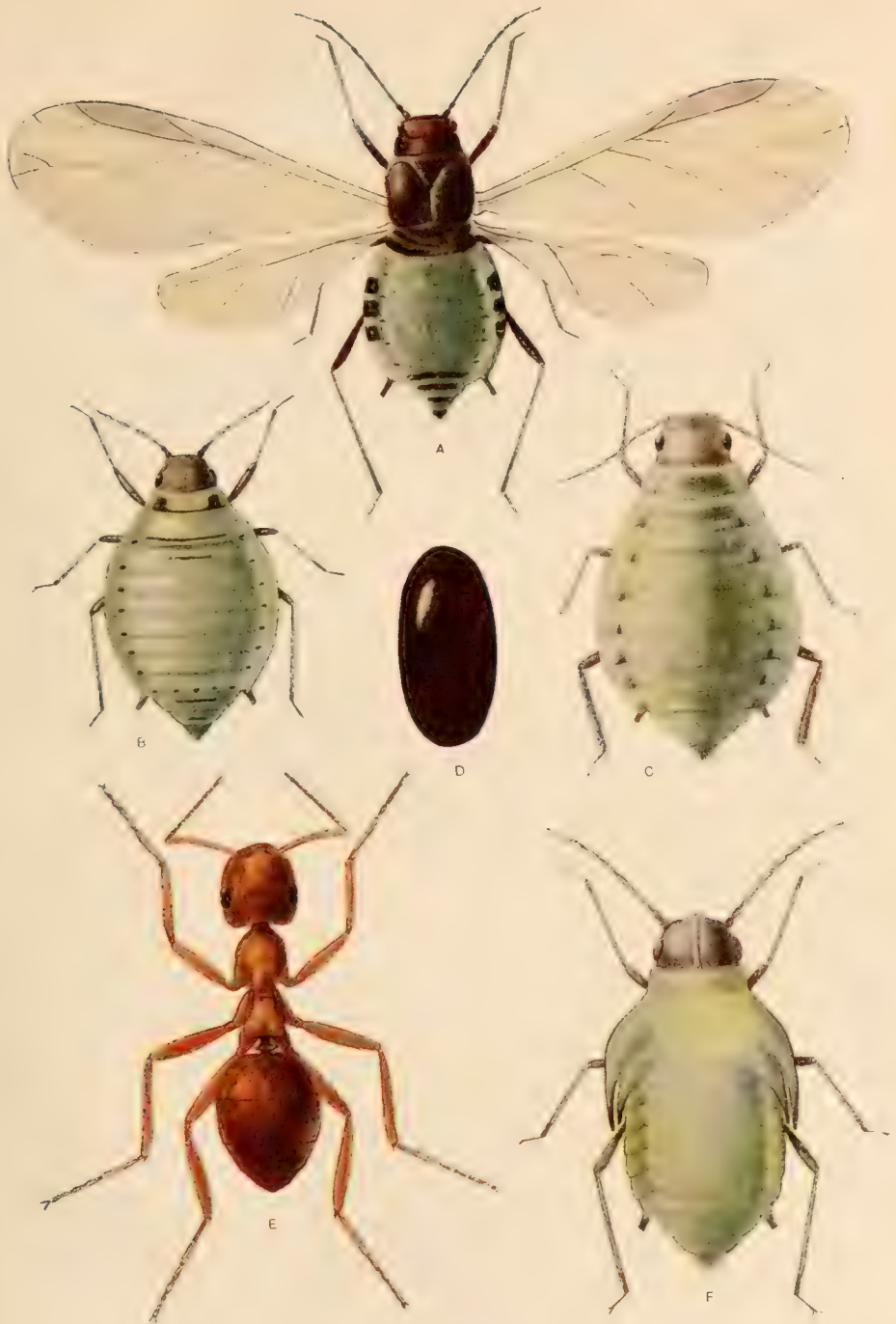

PLATE 27

THE CORN ROOT-LOUSE, (*Aphis maidiradicis*.) B, the common wingless and A, the winged viviparous females; F, the pupa of the winged female; C, the oviparous female, occurring in autumn and D, its egg, E, the worker of the root-lice ant (*Lasius niger americanus*.)



FIG. A



FIG. B

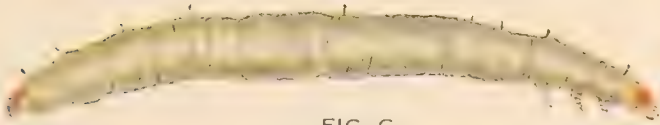

FIG. C



FIG D

CHARLOTTE M KING ARTIST

PLATE 26

CORN ROOT WORM, (*Diabrotica longicornis*.) A, Beetle; B, Pupa; C, Larva; D, Larva in Corn Root.



Lydia Moore Hart

PLATE 28

Fig. 1—THE SEED-CORN MAGGOT, *Pegomyia fusciceps*, adult. Fig. 2—THE CORN FLEA-BEETLE, *Chatconema Pulicaria*. Fig. 3—*C. confinis*.

Control—Rotation of crops is considered beneficial in checking injuries from these insects, as it will take some time for the plant lice to reach corn planted in a different field. Proper fertilization is also helpful, enabling the plants to make a good crop in spite of the attack. Land fertilized with barnyard manure is much less injured than where commercial fertilizers are used. Any means which will destroy the ants and their nests will be of practical importance owing to the fact that the ants house the eggs of the aphid during the winter. Deep plowing in late fall and early winter, and thorough harrowing will break up their nests and destroy the ants. Plowing may be carried out in the spring and will also break up the ants' nests. Grass and weeds upon which the aphides feed before the corn is grown may be destroyed in the same way. Thus spring cultivation is perhaps the most effective in controlling the pest.

THE WESTERN CORN ROOT-WORM

This insect has been called the Western Corn Root-worm because its injury was first noticed in Missouri and Kansas. It has spread gradually where corn has been grown on the same land during successive years, and has been reported throughout the corn states of the northern Mississippi valley.

Life History—We do not know all the details of the life history of this insect. The eggs are laid in the early fall near the base of the stalk, just below the surface of the soil. These eggs do not hatch until late in the spring. The larvæ destroy the small roots, eating them up entirely, and when they become larger they burrow under the outer cover of the larger roots. These attacks on the root tend to dwarf the plant and cause it to produce very small ears, and as the root system is eaten away there is frequently a tendency for the stalk to blow over and uproot the plant. When the grubs are full grown and are about one-tenth of an inch long, they leave the roots and pupate in small cells in the soil. The beetles will be seen from the middle of July throughout August. They are very small insects, being about one-fourth of an inch in length, of a greenish yellow color, resembling the cucumber beetle in shape. Their food consists of pollen and silk of the corn as long as that remains in fresh condition. Eggs are laid again during August and September.

Control—As this insect as far as known, has no food plant except corn, rotation of crops in which corn is not grown on the same land for more than two years in succession, will usually prevent its attack.

THE SEED-CORN MAGGOT

This insect (Plate 28, Fig. 1.) attacks early seed corn and sometimes beans and peas. It is then termed the bean fly. It also feeds

upon cabbage, turnips, radishes, onions, beets and sweet potatoes. It is very closely related to the root-maggot attacking cabbage and onions. The adults are of similar appearance.

Its life history is not very well known. The eggs are deposited either upon the young seedling just as it appears above ground or probably on the seed itself, in which case the seed fails to germinate. Examination shows the presence of one or more small seed maggots which have eaten out the germ of the young seedling. The maggots are about one-fourth of an inch long, slightly smaller than the onion maggot.

Control — Application of stable manure in the fall so that it may become well rotted and worked into the soil before seeding time has been found to prevent the attack of this insect. It has also been recommended that the seed-bed be rolled after planting to prevent the fly from gaining access to the seed.

BILL-BUGS

A group of beetles (Plate IV) with long tube-like beaks projecting from the front of their heads, giving them the name of Bill-Bugs, are sometimes injurious to young corn plants. There are several species varying in size from one-fourth to three-fourths of an inch in length and usually a dark brown or blackish color. The larva is a thick fleshy grub, from one-fourth to five-eighths of an inch in length.

Life History — The life history of the different species is not fully known. In general they are probably very similar. The winter is passed in the beetle stage, and the bugs usually appear in June and July, depositing their eggs very soon afterwards. The natural food of most of these insects is the club rush, the roots of which consist of bulbs connected by small slender rootlets. Eggs are deposited in or on the roots of this rush and the young larvæ burrow in the bulbs. Adults appear in August and September. Injury is done to the corn plant by the beetles eating into the lower part of the stalk; later they attack the upper portion of the plant and after the ears have begun to form, they often penetrate the husk and eat out the cob beneath. Sometimes the injury consists only of a puncture to the folded leaves, resulting in a straight row of small holes when the leaf opens, but sometimes they may kill the plant outright, or deform it so that no ear will grow.

Control — As the natural food of these beetles consists of roots and rushes and sedges, the bill-bug is found to be most injurious on recently cleared swamp lands. Draining the land and destroying the rushes cause the beetles to disappear. Burning over grass and swamp land where they are present will also kill many of them. It would be well to plant some crop as potatoes, which is distasteful to these insects, on newly cleared swamp land.



PLATE 29

Corn Bill-Bugs and larva, with injured corn plant.



PLATE 30

The Corn Worm: light and dark individuals, pupa, moth, and egg, with Injured ear of corn.

THE CORN EAR-WORM

This insect (Plate 30) is one of our cosmopolitan pests and has a very wide range of food plants, attacking tomatoes, tobacco, beans, peas, forage plants, and many other crops besides corn. For that reason it is often known as the tomato fruit-worm, tobacco budworm, or cotton boll-worm. It is the most destructive insect to corn, attacking the ear after it has begun to develop. It seems to be particularly



Fig. 8.—Corn-ear Worm—Husk of sugar corn torn open, showing worms at work on tip and hole through which a full-grown worm has left.

Courtesy of John Wiley & Sons

fond of sugar corn in the South and sweet corn in the North, although it attacks field corn to a considerable extent.

Life History—In the northern states the moth appears probably early in June, it is of a brownish or dark greenish color about the same size as the cutworm moth, to which group this insect belongs. The eggs are laid on corn or whatever food plants are available and hatch in a few days, the time varying slightly according to temperature.

This generation of caterpillars feeds upon the young corn, eating down into the axil of the leaves. As the plants grow and the leaves unroll, horizontal rows of holes appear where they have eaten. They only require about two and one-half weeks to attain their full growth, and pupation takes place in the soil at the base of the plant. In about two weeks as the corn is coming into tassel the adult moths emerge and place their eggs upon the silk. The young caterpillars find their way into the tips of the ears, gnawing out the forming kernels underneath the husk where their presence is not easily noticed.

A third generation of moths appears the last of August in the latitude of Kansas. The caterpillars produced from the eggs which these moths lay cause the greatest amount of injury to field corn and sorghum corn, often causing a loss of 10 or 15 per cent of the latter crop. Winter is spent in the soil as pupæ. In the northern states we probably have two generations during the season, in Canada probably only one, while in the Gulf states there are probably as many as four. It has been estimated that the corn ear-worm causes an annual loss to our corn crop in the United States of from \$30,000,000 to \$50,000,000.

Control—The first suggestion to be made in regard to its control is that all land should be fall or winter plowed. Plowing should be done deep and followed by harrowing. This will break up the pupal cells, killing many of the pupæ and exposing others to the winter weather. In the case of field corn, it should be planted as early as possible to prevent the moths from placing their eggs upon it. The first generation of caterpillars may be killed by dusting into the tops of the plants, powdered arsenate of lead, mixed with flour or corn meal. The powdered arsenate of lead may be dropped on the eggs of the worm when they begin to show. It has been claimed that in small areas this will destroy as high as 90 per cent of the caterpillars.

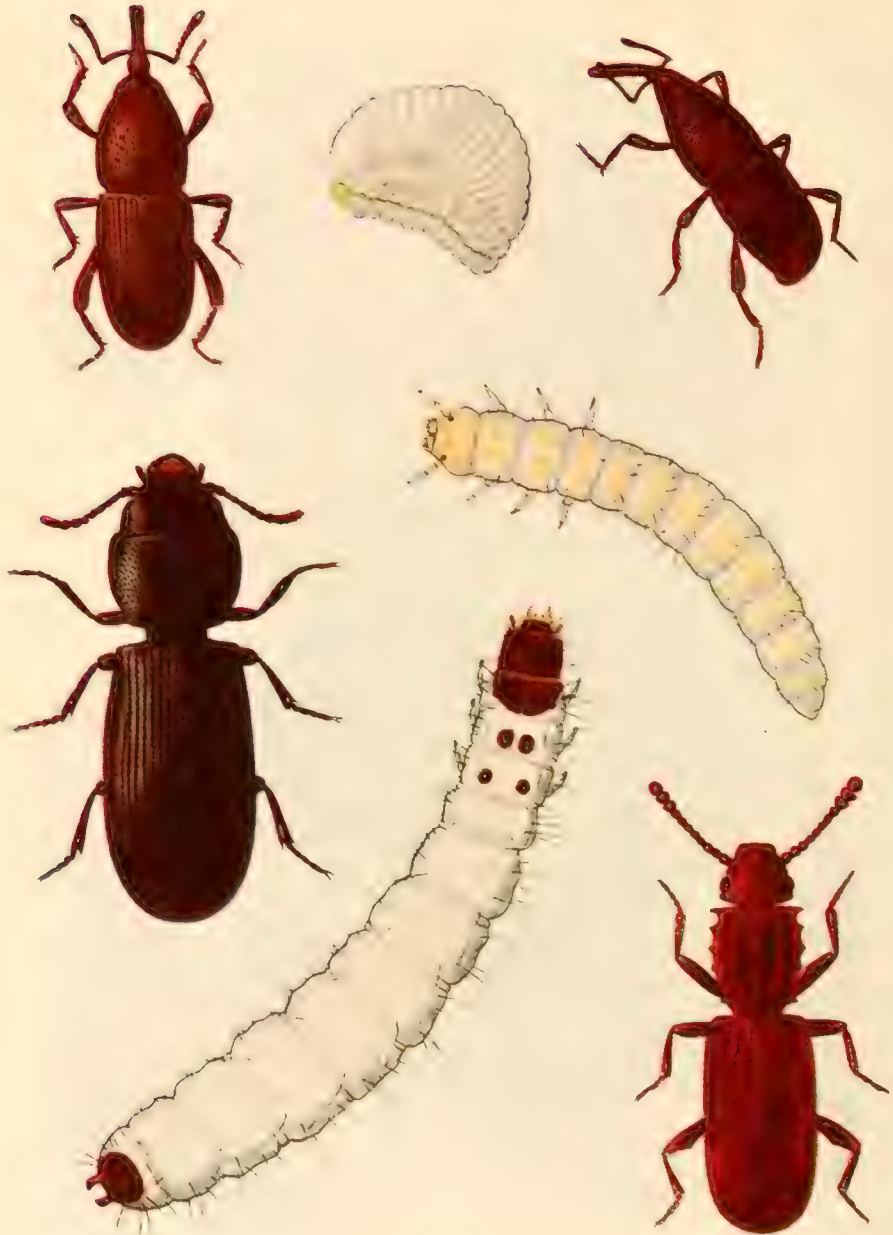

PLATE 32

The common grain Weevils and larvæ.

CHAPTER IV

INSECTS INJURIOUS TO STORED GRAINS

I. GRAIN WEEVILS. II. GRAIN BEETLES. III. FLOUR AND MEAL MOTHS. IV. THE ANGOUMOIS GRAIN MOTH.

It has been estimated that we lose in the United States each year at least 5 per cent of our cereal crops, after they have been put in storage. This means an annual loss of probably \$150,000,000 on the average. Something over fifty different kinds of insects called maggots have been found throughout the United States, attacking stored grain and food products. Only a few of these, however, are commonly injurious and need be treated here.

GRAIN WEEVILS

The term "weevil" is commonly applied to any insect attacking stored grains. It belongs strictly, however, to the rice weevil and grain weevil. These are small brownish beetles about one-eighth of an inch in length, with long snouts projecting from the front of their heads used for boring into the grain.

Both insects are very destructive in the United States, the rice weevil being more common in the South while the grain weevil is more abundant in the North, even existing as far north as Alaska. These insects have lived for so long in our stored cereals that the grain weevil has lost all of its wings and is no longer able to fly. The rice weevil is so called because it was usually found attacking rice, but it is just as fond of other kinds of grain. Both are very injurious to wheat and corn. The loss of corn in the South from these pests is sometimes very great. The adults feed upon the grain, boring into it with their long snouts. The eggs are also placed in the grain, the female boring into a kernel and placing an egg in the cavity. The larva hatched from this is legless and almost as broad as it is long.

Life History—Only one larva inhabits a grain of wheat, while several may be found in a grain of corn. About six weeks is required for the adult beetle to emerge, pupation taking place inside the kernel. The adult only emerges after it has become hardened and able to defend itself. Beetles are very long-lived and egg-laying continues over a considerable length of time. In the North three or four generations are laid in a season while in the South there are six or more. In warm storerooms, however, they will breed throughout the year, and

in the extreme South the rice weevil will probably breed throughout the greater part of the year out of doors.

THE SAW-TOOTHED GRAIN BEETLE

The Saw-toothed Grain Beetle is also very destructive throughout the country. It is similar to the grain weevil, flattened, dark brown in color and on each side of its thorax appear six small saw-like teeth. The larva of this beetle, unlike that of other beetles, is provided with legs and is able to move from one seed to another. When full grown it forms a small cocoon by gluing together small grains or fragments into a little case. The whole life period requires from four to ten weeks.

FLOUR AND MEAL MOTHS

Several moths are included under this heading. They usually prefer flour and meal as food for their young. The Mediterranean Flour Moth is perhaps the best known of these insects. It is also the most destructive insect to flour. It was first recognized in the year of 1877, and since that time has caused a heavy loss to mill owners. The caterpillars feed in the flour by means of a silken tube and surround themselves by a silken web which they spin whenever they move about. When ready to pupate they move about very widely and render the flour valueless by matting it together. This matted, lumpy flour clogs the machinery and in this way causes further damage. In favorable conditions the insect will breed throughout the year. The adult moth is a little larger than the clothes moth and of a lead grey color. Across the middle of each fore-wing there is a dirty, whitish band.

THE ANGOUMOIS GRAIN MOTH

This insect is known in the South as the "fly-weevil." It was discovered first in Angoumois, France, early in the eighteenth century, and was soon introduced into this country. It made its appearance first in stored corn in the southern states but in the last few years it has gone northward and has been reported in Pennsylvania and Ohio. It attacks wheat, corn, oats, rye, barley, sorghum, and cowpeas, but corn is probably the most seriously damaged grain.

Life History — Injury is done to the grain by the caterpillar as the adult moth is unable to feed. The moth, which resembles very closely the common clothes moth, appears in the fields about the time the grain is coming into head and lays her eggs upon the ripening kernels. Every female produces about seventy-five eggs, in lots of about twenty each. The young caterpillars hatch out in about six days and bore into the grain. They are so small that the openings which they make are unnoticeable. Several generations may mature within the kernels



PLATE 31

The Angoumois Grain Moth: larva, pupa, moth, and egg, with injured kernel and ear of corn.

during the summer and when the grain is harvested the grubs are carried with it into the barn to continue breeding throughout the winter. Corn is frequently attacked but not until it is ripe and husked and it may be spared if husked in October or November and stored in a cold place. Seed corn stored in barns in the South in almost any situation is often badly injured. Grain which has been attacked by this insect becomes entirely useless, even cattle and horses refusing to eat it.

Control — Many weevils are killed in threshing and many eggs are rubbed off at the same time. Grain should be dried as soon as possible and stored in tight bins so that upon emerging the moths may be stifled. If bins are tight the grain should be tested for heating. If it has heated considerably infestation is indicated and treating by carbon bisulphide is probably the best remedy.

How to Use Carbon Bisulphide — If the temperature is below 60° F. do not try to fumigate. Five pounds per 1,000 cubic feet, when the temperature is at 70° F. in a tight bin will kill practically all of the weevils. It does not pay to use it in loose open bins. Caution: the vapor is deadly to animal life if inhaled in large quantities. It is also highly **flammable**. Keep lanterns or lighted cigarettes away from it. Care should also be taken to sweep up and destroy loose grain lying about, so as to prevent breeding in such material.

CHAPTER V

INSECTS INJURIOUS TO CLOVER

- I. THE CLOVER ROOT-BORER. II. THE CLOVER LEAF WEEVIL. III. THE CLOVER-SEED MIDGE. IV. THE CLOVER-SEED CHALCID.

THE CLOVER ROOT-BORER

This insect occurs from New York, south to West Virginia and west toward the north central states. It was introduced into this country first from Europe in 1876.

Life History—Winter is spent by the adults hibernating inside infested clover roots. They are very difficult to see because of their small size, being about one-eighth of an inch in length, and of a dark reddish brown color. In spring they begin to feed in the roots and soon the females place their eggs in the tunnels which they have made in the roots. Every female lays about six eggs, the grubs hatching from these eggs burrow in the same root, feeding there until they are full grown, about the first of August. By October they have pupated and the fully developed beetle appears. They remain in the same place until the following spring, when they emerge and fly from field to field, seeking uninfested plants in which to lay their eggs.

Common red clover and mammoth clover seem to be more subject to attack than other varieties of clover. This pest has not been reported as attacking alfalfa in this country but it does so in Europe. An attacked plant is able to survive for a considerable time, but it soon dies out especially if the season is dry. During the first year clover is practically free from the pest as the roots are too small for the insect to work in them, but during the second year they are large enough to invite attack.

Control—As soon as the crop has been taken off the field in summer, it should be plowed up at once. Exposing the roots of the plant to the effect of sun and wind, dries them up and thus starves the grubs inside. Do not allow a clover field which is infested to stand two successive years. A system of rotation has been recommended in which the crop is cut for hay and seed the first year, pastured, and then broken up the second year.

THE CLOVER LEAF-WEEVIL

This is a small beetle about one-third of an inch in length with a long thick snout which is characteristic of the beetles known as

weevils. The color is brownish with gray lines and stripes on the sides. This is another importation from Europe, and has spread as far westward as Illinois and Wisconsin. Red clover, white clover and alfalfa are the preferred food and in Illinois the leaf-weevil is reported as feeding upon mammoth and alsike clover. It is rarely very injurious although outbreaks may occur in certain districts for short periods of time.

Life History—The winter is spent by the grubs in crevices only a short distance below the surface of the soil. In the spring they emerge and feed upon the foliage of the clover, becoming full grown in May or June. Feeding mostly during the night, in the daytime they are hidden away in the soil at the base of the plant, after the manner of the cutworm. The edges of the leaves are eaten in a regular manner, making their work noticeable and characteristic. After feeding for a time the grub burrows a short distance under the soil and transforms to the pupa. Its formation takes place in a cell lined with a delicate lining of silk. In July and October the beetles emerge from their pupal cases and proceed to feed upon the clover, doing as much injury as the grubs did before them. Eggs are laid by the female beetle early in the fall in crevices near the base of the plant. The larvæ hatch from these eggs and feed upon the clover until fall, when they go into hibernation.

Control—Plow and cultivate after the second season.

THE CLOVER-SEED MIDGE

This insect does much destruction to the seed crop. It occurs over practically the whole of the country. It does not seem to attack alsike or mammoth clover, because they flower late enough to escape. This insect is an extremely small fly of blackish color with reddish abdomen and is very rarely noticed on account of its small size.

Life History—When the clover begins to head in the spring the midges begin to appear and place their eggs beneath the bracts about the head and among the hairy spines. The orange colored maggots which hatch from the eggs work down into the flower where they suck the juice from the developing seed, and so prevent the heads from coming into full blossom. When full grown in late June, they enter the soil and spin tough silken cocoons just beneath the surface in which they pupate. After three weeks the second generation of flies appear, just in time to attack the second crop of clover heads. The second generation does more damage to the seed than the first generation. They live over the winter as maggots, pupating early the next spring or else they pupate before the frost and pass the winter in their silken cocoons.

Control—Clover should be cut early while the maggots are still

young; in this way the flower will dry up and the maggots will starve to death. The second crop of clover heads is also hastened and becomes mature before the second generation of midges can place their eggs upon it. Cutting can be done when the field is in full bloom. Another method is to cut clover in May, which will result in bringing both the first and second blooming after the midges have disappeared. Volunteer clover affords a good breeding place for these insects and should never be allowed to grow.

THE CLOVER-SEED CHALCID

This insect often comes in large numbers to the ripening clover field. The adult is a very small four-winged fly which places its eggs in the soft heads of the clover, just as the flowerets are withering. The maggot-like larva feeds upon the head, thus gradually hollowing it out and transforming in the empty shell. The adults emerge about the middle of August, and place their eggs in the heads of the second crop of clover. Some of the adults of this second generation appear the same season and the rest not until the spring of the following year, usually early in June. It is very hard to detect the presence of this insect, because of the tiny size of the fly and the grub's method of concealment, except by close examination of the heads, many of which will be found shriveled and misshapen. If many empty hulls are blown out with the chaff at threshing time the presence of the chalcid may be suspected. It appears to be found in all parts of the country where clover is grown, attacking the heads of red and crimson clover and to some extent alfalfa. There is often a loss of 20 to 80 per cent of seeds.

Control—The same manner of control as was suggested for the clover-seed midge will prove effective for this insect.

CHAPTER VI

INSECTS INJURIOUS TO POTATOES AND TOMATOES

- I. POTATO STALK-BORER. II. THE STALK BORER. III. COLORADO POTATO BEETLE.
IV. BLISTER BEETLES.

THE POTATO STALK BORER

This insect has been injurious in America for some years and often does as much damage as the Colorado potato beetle. Injury is done by the grubs burrowing through the stalks of the potato vine.

Life History—The beetles appear early in the spring. They are small, only about a quarter of an inch long. They are gray in color and with long snouts. The female beetles make a small hole at the bottom of the potato stem in which they place their eggs. The grubs hatch from the eggs in a few days and begin to bore into the stalk. They burrow through the stalk and its branches, feeding as they go, until August or September when they are full grown. The grubs are now of a yellowish color with darker head and about one-half inch in length. They pupate in the stalk where they have been boring down near the surface of the ground, forming their cocoons by gluing together fibers and castings from the stalk. The beetles appear in August or September, but they remain in the potato vines until the next spring.

Control—Inasmuch as this insect works inside of the potato stems, it is difficult to control by our usual methods. The most obvious thing to do is to gather the vines in the fall as soon as the potatoes have been dug, and burn them. Fertilizing the crops will quicken the growth and help in overcoming the attack of the insect. Weeds should be kept cut down closely as the stalk borer is willing to feed upon such weeds as horse nettle, Jamestown weed, and others of the nightshade family.

THE STALK-BORER

This insect should be distinguished from the potato stalk-borer for the reason that it not only burrows the stalk of the potato but quite as commonly the stalk of tomatoes, corn, cotton, grain, grasses and many other plants and weeds found in our gardens. There are several related species with similar habits. The adult is a yellowish-gray or mouse color, the outer one-third of the fore-wings being lighter in

color and bordered within by a whitish line. It looks somewhat like the adult of the cutworm.

Life History—Probably the original food of these insects was wild weeds and grasses, but they have taken to the cultivated crops whenever they have the opportunity. The moths appear in the fall and place masses of eggs, fifty to sixty in every mass, on the lower part of the stems of the grass and weeds. These eggs pass the winter and



Fig. 9.—Colorado Potato Beetles, showing various stages of development; also two blister-beetles often called 'old-fashioned potato beetles.'

Courtesy of the Minnesota Experiment Station

hatch late in May in southern Minnesota. The caterpillars begin their work by forming mines in the substance of the leaves of the plants on which the eggs are placed. As soon as the leaves have been riddled with burrows they work down to the base and into the stalks in which they tunnel. Infested plants are quickly recognized by wilting of the leaves above the place where the caterpillars are working, as they cut off the sap. If one plant does not furnish sufficient food, they may leave it and enter a second, traveling some distance in doing so.

The caterpillar is full grown early in August. It transforms to a pupa in the burrow which it has made in the stalk of the plant and in about two or three weeks, usually late in August, the moth appears. Before the caterpillar pupated, it cut a hole through the side of the stalk to allow for the emergence of the moth. The caterpillars are marked in such a way as to be quickly recognized. When full grown they are about one inch long and their color varies from purplish to whitish brown. A white stripe extends down the middle of the back and two on either side. These stripes, however, are absent on the first four segments of the abdomen.

As a rule crops are injured only on the outer edges of the field where the caterpillars have moved in from the weeds at the sides. Where weeds have been unheeded in the field, injury is apt to be much greater. The damage is particularly noticeable in corn.

Control—As weeds and grass are the natural food of these insects, the most effective way of suppressing them is to get rid of the weeds. Plow in the fall and burn the weeds to destroy the eggs which are laid upon them. Clean cultivation will do more than anything else to destroy the insect. Infested plants should be cut out as soon as discovered.

THE COLORADO POTATO BEETLE

This insect is probably the best known of all the insects that attack potatoes. Aside from the great amount of injury which it has done to potatoes, it is of interest for the reason that Paris green came into use as an insecticide through the struggle to find a remedy for this devouring pest. It is also interesting because it shows how new insects frequently appear as pests on cultivated crops. The Colorado Potato Beetle was a native of the Rocky Mountain region where it fed upon wild plants related to the potato. In about 1855 the country in Colorado began to be settled and the Irish potato was planted upon the farms. The beetles were not long in seeing that here was a good food plant of the same nature as their native food, and presented themselves in the fields in great abundance. They spread eastward very rapidly. By 1859 they had reached a point east of Omaha, Nebraska. In another five years they were in Illinois, and by 1874 they were on the Atlantic coast. They are now found practically everywhere that the potato is grown in the United States and Canada, and have been introduced into England and Germany. Their well known appearance needs no description.

Life History—The beetles spend the winter in hibernation in the soil coming out in April or May. The female lays her eggs on the under side of the leaves of the first shoots. These eggs are bright yellow or orange color, very easily noticed, and about 500 are deposited

by every beetle. The eggs hatch in about seven days, and the red grubs begin to feed upon the leaves, growing very rapidly. Although the old beetles have done some injury to the plants previous to this, the real damage is accomplished by the devouring appetites of the slugs. In seventeen to twenty-one days these well-known grubs are full grown and go down into the soil where they make little cells and transform into pupæ. The pupæ produce the beetles in a week or two and these beetles after feeding a short time upon the potato lay their eggs for the second generation. The beetles of the second generation are known to remain in the soil over winter. In the extreme North there is only one generation a season, and in the extreme South probably a part of the third generation.

Fortunately the potato beetle has a number of natural enemies, otherwise it would be far more numerous than it is at present. The

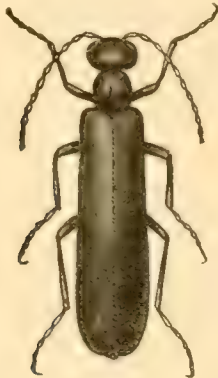

Fig. 10.—Black Blister Beetle.

Courtesy of the Minnesota Experiment Station

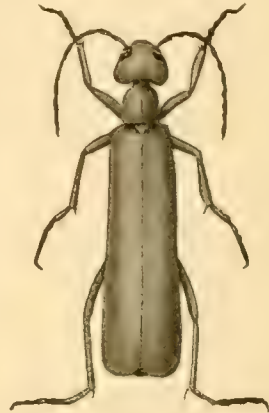

Fig. 11.—Gray Blister Beetle.

larvæ of the tachina fly destroy the grubs; some of our common lady-bird beetles devour the eggs, and some of our birds such as the crow, red-breasted grosbeak and turkeys feed upon them. The weather probably does most to prevent their multiplication. A few warm days very late in autumn may bring the beetles from their winter quarters and if there is no food present or if frost follows quickly, they will be destroyed.

Control—A spray of arsenate of lead or Paris green is the most usual method of controlling this pest. The spraying should be done when the insects first appear in the spring. Use one pound of Paris green to 50 gallons of water; three to four pounds of arsenate of lead paste should be used to 50 gallons of water. These quantities are sufficient to spray one acre of potatoes.

BLISTER BEETLES

There are several species of Blister Beetles, known in some places

as the old-fashioned potato bug, as they were a well established enemy of potatoes before the Colorado potato beetle appeared. They are called blister beetles for the reason that they contain a certain chemical which has a blistering effect to the skin. This chemical is extracted and sold under the name of "Spanish fly." They present an interesting problem for the reason that while the adults are injurious to potatoes and several other garden and farm crops, the immature forms are beneficial, feeding upon the eggs of injurious grasshoppers. The most common beetle has a long black or gray body with three yellow stripes down the wing-covers. The different species do great damage to the foliage of garden crops, attacking sugar beets, potatoes, beans, and other legumes.

Life History—The female beetle places her eggs in small cavities in the soil. From these hatch small larvæ which are very active, and immediately start out in search of egg pods of the grasshopper which have been placed in the soil at about the time that the blister eggs were laid. As soon as they find a pod of eggs they enter and suck out the contents of one or more eggs. A very peculiar transformation takes place at this time. At first when it must go in search of food the larva is provided with long legs, but now when surrounded with an abundance of food, its legs are no longer needed and disappear. The growth is completed during the next spring, the adults appearing about midsummer.

Control—If the potato vines are regularly sprayed with Paris green or arsenate of lead, they will not be troubled with the beetles. When they are present in large numbers, as they move very slowly they may be frequently driven into a windrow of straw or hay by a line of men with branches of trees and then burned. Sometimes they appear very suddenly upon a crop and after doing considerable damage fly away again to some other field for no apparent reason.

CHAPTER VII

INSECTS INJURIOUS TO BEANS AND PEAS

- I. THE PEA WEEVIL. II. THE COMMON BEAN WEEVIL. III. BLISTER BEETLES.
IV. THE PEA-APHIS.

THE PEA WEEVIL

This insect is not very common in the northern states but does considerable damage to peas in many southern regions. It is the largest of the pea and bean weevils. The weevil can be quickly recognized by its wedge-shaped outline, the wing-covers being so short that the abdomen projects behind. It is covered with a fine coating of down with black or white markings. The thighs of the hind legs are thickened and bear two prominent teeth each.

Life History—The weevils which have passed the winter appear in the field about the time when the peas are in blossom. They place their eggs one by one on the surface of the young pods, covering them over with sticky white cement. As soon as it hatches the young grub immediately works down into the seed through the pod. It at once sheds its skin losing its legs for which it has no more use. The grubs are thick, soft and fleshy, slightly curled, with dark colored heads and mouth parts. When full grown they are about a half inch long. Full growth is reached inside of the pea and the grub there changes to a pupa, this stage lasting from two to three weeks. In the South the insect leaves the seed in August but in the North it remains in the seed until planting the following spring. The weevils do not breed in dry peas in storage.

Control—It has been claimed by some growers that they can preserve their peas from attack by planting them later than the usual date. Fumigation with carbon bisulphide will kill the weevils which are in the peas. For a small quantity of seed, an ordinary kerosene barrel can be used in fumigation. It will hold about five bushels of seed and will require three ounces of carbon bisulphide. The top of the barrel can be covered tightly with a cap made for the purpose or with old sacks thrown over the top and held down with boards. A temperature of 145° F. will destroy any weevils found in the seed without injury to the germination properties. Seed may be held over for a season by which time the adults will have emerged and left the seed free. Such peas should be stored in tight sacks to prevent

the escape of the weevils. For further directions for use of carbon bisulphide see Chapter I, under "Fumigants."

THE BEAN WEEVIL

This is a common enemy of the bean throughout the United States. The adult weevil can be distinguished from the pea weevil by the presence of two small teeth next to the large tooth on the thighs of the hind legs. It is darker colored than the pea weevil, and the thorax is longer. The weevils breed in the bean both in the field and in storage.

Life History — In the North, it is more commonly found as a pest of storage beans, but in the South it does an immense injury to the bean crop. In storage the eggs are placed loosely among the beans or upon them, or in the holes from which other beetles have emerged. As with the pea weevil, the grub at first has long legs which enable it to move about easily, but these are lost with the first molt, and when full grown it is a fat, thick, footless grub resembling that of the pea weevil. In the field the eggs are placed upon the outside of the bean pod or inserted through cracks or holes which the females make in the pod. Their life cycle requires a variable time depending upon the season and the locality. Several grubs may develop in the same bean so that it will be completely ruined for seed or for food. It is never safe to plant "weevilly" seed, as only a small portion of the seeds will germinate.

Control — Before planting treat the seed with heat or carbon bisulphide, as used for the pea weevil. If seed is thrown in water, the infested seed will float and can be separated and destroyed.

Blister Beetles — Several species of blister beetles feed on the foliage and flowers of the bean. They have been discussed in Chapter VI.

THE PEA-APHIS

Since 1899 these large green plant lice have caused very severe loss to pea growers in the eastern and north central states. In that year and the one following the loss was estimated at several million dollars. They sometimes become so numerous as to kill the plants completely by sucking out all their juices. The insect is pea-green in color with a light brownish head. The eyes are red and the legs, antennæ and honey tubes are yellowish, tipped with black. The wingless forms are predominant but some winged forms are present throughout the season.

Life History — The insects feed upon clover and vetches, and upon these plants they usually spend the winter, passing over to other peas in the spring, when they are from six to eight inches high. The winged

aphides give birth to wingless females, and generation after generation are produced rapidly throughout the summer; each individual lives about twenty-five days and produces from fifty to one hundred young during that time. Fortunately they have many enemies in the way of parasitic and predaceous insects and diseases which reduce the number rapidly in midsummer, although not until after the injury has been done to the peas, unfortunately. They may again be injurious to the late garden peas. In the autumn they migrate back again to the clover. Winged males appear at this time and eggs are deposited upon the clover. These eggs are very tiny, oval, shiny black specks placed down among the lower stems of the clover plants where they remain until next spring.

Control — A fungous disease helps very materially in keeping this insect in check. The lady-bird beetles and maggots of the syrphus flies and lace-winged flies also destroy a great many. Do not plant clover near where peas are planted, thus providing the shelter in which they spend the winter. Grow as early varieties of peas as possible for they are not so apt to be attacked. Where peas are grown in rows a modification of the hopper-dozer used for the grasshopper may be applied. This pan is drawn between the rows and the vines are brushed with a branch causing the aphides to drop into it.

A spray of whale-oil soap, one pound to six gallons of water is effective. Tobacco extract or 5 per cent kerosene emulsion may also be used. Spraying should be done as soon as the aphides are found abundantly upon the plants.

CHAPTER VIII

INSECTS INJURIOUS TO BEETS, SPINACH AND CABBAGE

- I. THE SUGAR-BEET WEBWORM. II. BLISTER BEETLES. III. THE CABBAGE MAGGOT.
IV. THE IMPORTED CABBAGE WORM.

THE SUGAR-BEET WEBWORM

This insect is a serious pest of the sugar beets of Kansas, Nebraska, and Colorado. It also feeds upon several garden and field crops such as onions, cabbage, alfalfa and some weeds such as the pigweed. It is a native of northern Asia and was probably introduced into this country from that source. The caterpillar is about one inch long, dark in color with a light stripe down the back and one on each side. Numerous black and white tubercles project on each segment of the body.

Life History—The moths appear about the middle of May and place their eggs on the leaves of pigweed and alfalfa, sometimes one by one, but ordinarily in groups of several. There are three generations a year, the third generation in August is the one which does the most injury to beets. They defoliate the plants, covering the leaves with a webwork of silk as they devour the leaves. The first generation of the season is usually passed upon weeds such as the pigweed and upon alfalfa. The second generation does a slight amount of injury to beets. The winter is passed by the caterpillar in the soil.

Control—A spray of Paris green or arsenate of lead will destroy the beetles. Weeds should be destroyed in the vicinity as they furnish the food for the first generation of the caterpillars. Late fall plowing will break up the pupal cells in the soil.

Blister Beetles—A discussion of these insects will be found in Chapter VI. They are particularly troublesome in the northern Mississippi Valley where they may be very destructive to sugar beets. Swarms settle down in the field, large enough to strip it bare, and then move on to another field.

THE CABBAGE MAGGOT

This is undoubtedly the most destructive and most difficult to combat of any insect attacking the cabbage. It also feeds upon related plants such as cauliflower and radishes. Working as it does in the roots, its presence is difficult to recognize until we see the plant suddenly wilt and die. This insect is the maggot of a small fly somewhat resembling the house fly but very much smaller. If the wilted plants

are examined, it will be found that the roots have been eaten by the maggots. Early planted cabbage, cauliflower and radishes are most affected. Later in the season the maggots will be found in radishes and turnips and wild mustard.

Life History—The flies appear very early in the spring about the time when cabbages are being planted. They place their eggs either on the stems of the plants or on the soil close to the stems, preferably upon the plant so that the maggots will be near their food supply. One or two eggs are placed on a plant but each female may produce fifty eggs. These hatch in from three to ten days and the little maggots at once work down to the tender roots, gradually mining into them. Three or four weeks are required for them to reach full growth. The maggots resemble very closely those of the house fly. As soon as they are full grown, they burrow into the soil. The skin contracts and becomes hard and dark brown, serving as a cell in which the maggot transforms to the pupa. Such a shell is called a puparium. Sometimes these puparia are formed in the burrows where the maggots were working in the roots of the cabbage. In about two weeks in the summer time, the flies appear again. The maggots of the second generation are not as destructive as those of the first. The winter is spent as puparia in the soil or in the roots of their food plants.

Control—Gather and destroy all the remains of the crop in the fall. Then plow the land, thus removing or destroying all the puparia which would survive the winter. Cabbage planted late on uninfected land is quite safe as the flies will have disappeared to a great extent before the plants are put out. Many growers place about the cabbage at the time of planting a disk of heavy tarred paper. These disks are cut in a six-sided shape, slit to the center, and marked with short cross cuts at this point to receive the stem of the plant. The earth is smoothed down about a newly set plant to which the card is applied and pressed down tight to the ground. This will prevent the fly from reaching the stem of the plant to deposit its eggs. Abundant fertilization will help the plants to withstand attack.

THE IMPORTED CABBAGE WORM

The small white butterfly (Fig. 12) bearing black marks on the tip of each fore-wing which is so commonly seen about our gardens, is the parent of the Imported Cabbage Worm. It is a native of Europe having been imported into this country about 1860. The caterpillars are the common green velvety looking worms which are found eating large holes in cabbage leaves.

Life History—The butterfly appears very early in the spring and lays its eggs at once upon whatever food plant is available. The caterpillars will feed upon many of the cultivated and wild plants which

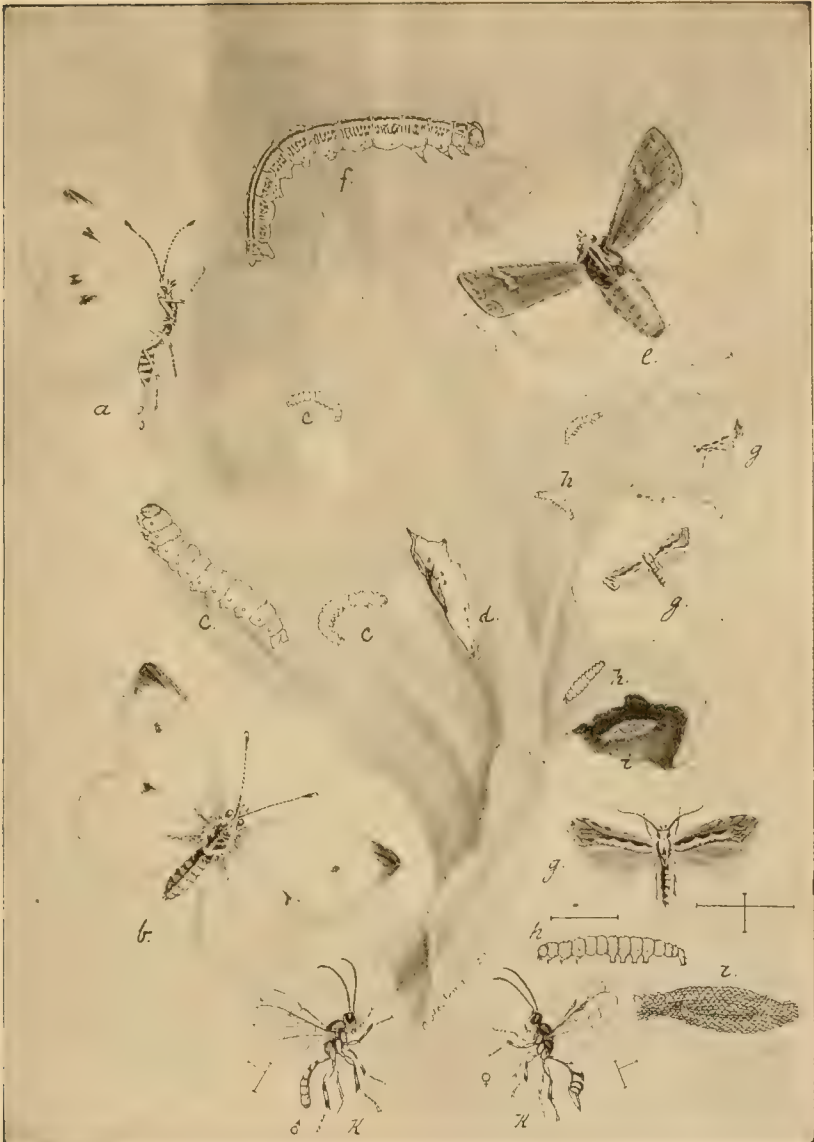

Fig. 12.—Pests of Cabbage—Stages of imported cabbage butterfly, cabbage zebra caterpillar, cabbage phitella and its parasites.

Courtesy of the Minnesota Experiment Station

are related to the cabbage. Eggs hatch in from four to eight days, and the caterpillars skeletonize the leaves so rapidly that they are full grown in about two weeks. They then curl themselves up in some protected place and transform to an angular greenish colored chrysalis. The butterflies emerge in about two weeks. There are several generations during the summer. The chrysalides of the last generation pass over the winter on the remains of the cabbage plants or among other rubbish in the field.

Control—The natural parasites of the cabbage worm are becoming so widespread that in some regions it is now rarely injurious. All the remains of the crops should be removed from the field in the fall, for in this way the insects, in their cocoons are gathered up and destroyed. Plowing the field in the fall will destroy any chrysalides which might be left behind. The plants may be sprayed and dusted with Paris green or arsenate of lead. To this spray should be added two or three pounds of resin soap and flour paste in order to make it stick more easily to the glossy foliage of the cabbage. Apply the spray as soon as the plants are set out in the spring and continue until the head is half formed. There need be no fear of eating cabbage that has been sprayed in this way as it has been shown that for a person to secure enough poison to cause serious results, it would be necessary for him to eat twenty-eight cabbages at one sitting.

CHAPTER IX
INSECTS INJURIOUS TO MELONS, CUCUMBERS,
SQUASH, ETC.

I. THE STRIPED CUCUMBER BEETLE. II. THE SQUASH BUG.

THE STRIPED CUCUMBER BEETLE

This insect (Fig. 13) is well known to all growers of cucumbers, melons and other related crops throughout the United States east of the Rocky Mountains. It is a small beetle about two-fifths of an inch long, longer than wide and of a bright yellow color except for the head which is black, and three black stripes extending down the wing-covers. It is often called the "striped bug" or "melon bug." The insects fall

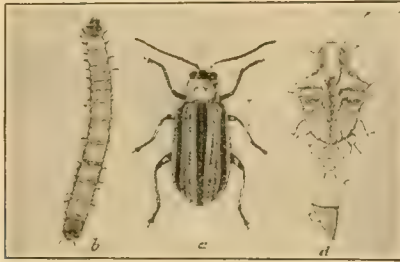

Fig. 13.—Striped Cucumber Beetle.
Courtesy of the University of Minnesota.

upon the young cucumber and melon plants just as the first two tender leaves are appearing above the soil and devour them so ravenously that often reseeding is necessary.

Life History—The beetles which destroy the young plants in the spring have spent the winter hidden away in the ground or under rubbish where they can obtain shelter. When they come out in the spring they will feed upon almost anything until the young squash, melons and cucumbers are coming through the soil. After feeding for a few days, they begin to deposit their eggs. These are dropped singly in crevices in the soil or around the stems of plants. About one hundred of these bright yellow eggs are laid by each female during a period of a month. The larvæ which come from the eggs are white grubs about three-tenths of an inch in length with darker head and thorax. These grubs work inside of the roots and may tunnel into the base of the stem. In this way they may sometimes kill large quantities of plants. At another time their presence is not noticed. In about four weeks they leave the plants and form cells in the soil

where they transform to pupæ, the beetles emerging in one or two weeks. The latter part of the summer the beetles feed upon the flowers particularly of the squash, and are not so apt to eat the leaves and plants. One or two generations occur every year. The beetles seek shelter as soon as frost appears and hibernate until the next spring.

Control—It has long been known that if young plants are covered with some substance which is distasteful to the beetles, they will not attack them. For this purpose arsenate of lead mixed with sulphur has been used. This substance should be applied in the morning while the dew is on the plants, and should be repeated as often as washed off. A spray of arsenate of lead is effectively used in the proportion



Fig. 14.—Eggs of the Squash Bug enlarged.

Courtesy of John Wiley & Sons.

of three to five pounds to each barrel of water. Paris green spray may be used. The difficulty is in applying the spray to all parts of the plant, as the beetle quickly learns to avoid the sprayed portions. Where only a few plants are to be protected, a fine wire netting can be placed over them. Some growers plant their seed in groups rather thickly and then thin out after the beetles complete their work. Others plant a row of squash around and through the field a week or ten days before planting the regular crop. The beetles are particularly fond of squash plants and will be attracted to them and may be killed by spraying with kerosene after they have all assembled on the plants.

THE SQUASH BUG

These insects are also very well and very unfavorably known for their attack upon squash and other gourd vines. They are dark brown-



Fig. 15.—Squash-bugs and Nymphs at work on young plants.
Courtesy of John Wiley & Sons.

ish in color, about three-fourths of an inch long and have a peculiar pungent odor. They attack the squash about the time the vines begin to run, and their work is usually noticed by the withering of a few leaves. If one searches at that time the bugs will usually be found hidden away in the soil or rubbish near the vines.

Life History—The adult insect spends the winter as does the cucumber beetle in protected places such as under boards, logs or rubbish, and comes out in the spring when the vines are of fairly large size. They place their eggs on the under side of the leaves in irregular clusters (Fig. 14). These eggs are yellowish brown but later grow darker. In a few days the eggs hatch into a form very much resembling that of the adult, except for its brilliant colors and the lack of wings. These insects never pass through a resting stage as do the beetles of butterflies, but like the grasshopper continue feeding and shedding their skins, every time becoming more like the adult insect, until in the last molt they appear as mature bugs. They are sucking insects and the young nymphs remain near each other sucking the juice from the leaves, thus causing them to wilt. They mature about August, and continue to feed until frost when they go into winter quarters. In the South there may be two or even three generations.

Control—It is impossible to kill these bugs by insecticides such as Paris green or arsenate of lead for the reason that they do not feed upon the foliage. A spray of kerosene emulsion will kill many of the nymphs if applied so as to cover their bodies. The adult bugs can sometimes be trapped under bits of board placed near the vines to furnish a convenient hiding place for them at night. They should be visited in the morning and the bugs gathered and destroyed. The eggs are very easily seen because of their bright color, and where only a few vines are grown they should be easy to collect and destroy. A trap crop of squash may be grown with cucumbers and melons in the same manner as recommended for cucumber beetles. Clear off all remains of the crop or other rubbish in the field and burn it. This will destroy the wintering places of many bugs.

CHAPTER X

INSECTS INJURIOUS TO MISCELLANEOUS GARDEN CROPS

- I. THE PALE-STRIPED FLEA-BEETLE. II. THE TARNISHED PLANT-BUG. III. THE CELERY OR GREENHOUSE LEAF-TYER. IV. THE CELERY CATERPILLAR. V. THE IMPORTED ONION MAGGOT. VI. THE ASPARAGUS-BEETLE.

THE PALE-STRIPED FLEA-BEETLE

These insects are found throughout most of the United States but have been most injurious in the middle states. They will feed upon almost anything. While they are especially fond of corn and tomatoes, practically all crops such as potatoes, turnips, cotton, melons, and even many common weeds have supplied them with food. The beetles are very small, not more than one-eighth of an inch in length. The body is cream color with three light brown stripes on the wing-covers. They have been called the flea-beetle because the hind legs are fitted for jumping and they are very active when disturbed. The eyes and the abdomen are black.

Life History—Their life history is not well known. The beetles seem to appear late in June and early July. Enormous numbers are present at this time and they at once attack the foliage of any crop that may be present, two or three days being sufficient as a rule to completely defoliate the crop. Eggs are deposited at about this time and the grubs feed on the roots of some of the common weeds. They do not attain full growth until the next May, and from these the beetles appear again in June.

Control—Destroy all weeds in which the grubs may develop. These should be plowed under as deeply as possible late in the summer. Some of the weeds upon which they prefer to feed are lambs' quarters and Jamestown weed. A spray of a boiled mixture containing three pounds of arsenate of lead to a barrel of water will drive them from the foliage when they are attacking a crop, or a plain spray of arsenate of lead will be effective.

THE TARNISHED PLANT-BUG

This is a very common insect throughout the United States and Canada. It seems to feed upon almost any plant, attacking mostly our garden crops and even the tender shoots of trees. Some of the common weeds serve as food plants. Injury is done by the bugs sucking

juice from the leaves and stems and thus deforming them. With some plants such as tomatoes and potatoes, they cause the destruction of the terminal shoots. The tarnished plant-bug is about one-fourth of an inch in length and of a dark brassy color, marked with black and yellow spots. The eggs are placed on the stems or the leaves of plants, sometimes in fruits. Apples are frequently deformed by the placing of these eggs, producing what is called "dimpling" the apple. The nymphs feed upon the same plants as the adults, passing through four stages of growth before they obtain their wings in October. There is probably only one generation every year. The adults appear in June or July and remain over the rest of the summer and during the winter until the next spring.

Control—The adults are very easily disturbed and fly very readily. From the fact that they feed by sucking out the sap from the tissues of the plant they are very hard to combat. Stomach poisoning is of course out of the question. A 10 per cent kerosene emulsion will destroy many of the nymphs as they are unable to fly. It has been observed that they are worst where weeds have been allowed to grow and where refuse such as leaves has been allowed to remain on the ground. It would be well, therefore, to practice clean cultivation, destroying all weeds and cleaning away all refuse from the ground in the fall, in that way destroying their winter hiding places.

THE CELERY OR GREENHOUSE LEAF-TYER

While this insect attacks many crops such as cabbage, cauliflower, lettuce, beets, tobacco, parsley, cucumbers, strawberries and sweet peas, it seems to be most injurious to celery. It often occurs in greenhouses attacking violets, roses, carnations, chrysanthemums, and many other greenhouse plants. Upon the foliage of the celery the caterpillar spins a web of silk under which it skeletonizes the leaves. Another time it may burrow into the stems. Its most common method of feeding, however, is to fasten together two leaves or curl up in a single leaf within which it feeds. The caterpillars are about one-fourth of an inch long, of a light greenish color, darker green bands extending down the back. They are found practically over the whole of the United States. About three or five weeks are required for the growth of the caterpillars which then pupate inside the webs spun between the leaves. From these the moths appear about one or two weeks later. There are probably about three generations every season, but in greenhouses they will breed as long as food is available and the temperature favorable.

Control—A spray of arsenate of lead applied before the caterpillars have webbed up the foliage to any extent will destroy them. After the leaves have been folded together, hand-picking seems to be about the only practical remedy.

THE CELERY CATERPILLAR

Most every one is familiar with a large black swallowtail butterfly with yellow bands extending across the wings. They are called swallowtail butterflies because the hind-wing ends in a distinct tail. The larvæ are the large green velvety caterpillars bearing spotted and ringed black stripes that we find so commonly feeding upon celery, carrots and parsley. They feed not only upon the foliage but also upon the flowers and the seeds.

Life History—These butterflies may appear as early as May and soon place their eggs upon the foliage. When the caterpillars first hatch from these eggs they are nearly black in color with a white band around the middle of the body, a color pattern which is sometimes protective. When about half grown, they assume the green and black alternating stripes. About three weeks are required for the caterpillar to reach full growth. It then seeks out some protected part of the stem of the plant upon which it has been feeding and suspending itself by silken threads it transforms to a large angular brownish chrysalis. The butterfly emerges from the chrysalis in about two weeks. There usually are two generations a year in the North.

Control—If unusually abundant, a spray of arsenate of lead will be effective. Sometimes the caterpillars occur in comparatively few numbers and are so easily seen that they can be hand-picked and destroyed.

THE IMPORTED ONION-MAGGOT

This insect was imported into this country in colonial days and is probably the most destructive pest of the onion. The trouble is caused by a white maggot working in the bulbs and causing them to wilt or decay. The adult is a fly somewhat resembling the house-fly but much smaller.

Life History—About the time the young onions are up in the spring, the flies are on hand. Two to six eggs are placed upon every plant in the sheath or axils of the new leaves. When the maggots hatch they work their way down to the root eating out the interior and often completely cutting off the plants; one maggot may thus destroy many onions. Later in the summer they will burrow into the bulbs, many being found in a single bulb. Such bulbs usually rot when placed in storage. The presence of these insects is easily recognized by the wilting of young plants and the yellowing of the leaves of the older plants. Only about two weeks are required for them to reach full growth. The pupæ are formed in the soil near the base of the onions, and in about two more weeks the flies appear. Two or three generations follow each other in the North. Both flies and pupæ spend the winter in the soil.

Control—Rotation of crops is of value, planting the onions as far from the field where they were grown the previous year as possible. Clean cultivation will also be effective, destroying all the refuse left in the field in the fall. Deep fall plowing destroys many of the pupæ which have been left in the soil. As soon as the plants are noticed to be affected they should be pulled up and destroyed, making sure no maggots are left behind in the soil.

THE ASPARAGUS-BEETLE

This insect is a pest which has been introduced from Europe. Beginning in New York, it has spread southward to North Carolina and westward as far as Wisconsin. The beetle is about one-fourth inch long, bluish black in color with a red thorax and light yellow spots on the wing-covers. Injury is done by both grubs and adult beetles feeding upon the older plants later in the summer. The injury of the young shoots make them unsalable.

Life History—The winter is spent by the beetles in hibernation under rubbish in asparagus beds. They come out at about the time the asparagus will be cut for market and place their eggs upon the young shoots. In a very few days the eggs hatch into grubs which begin to feed on the shoots. About ten or fourteen days are required for the grubs to become full grown, in which time they are one-third of an inch long and of dark grayish or greenish color. Pupation takes place in the soil. The beetles come out about a week later. There are only two generations every season.

Control—The beetles have many natural enemies, especially the lady-bird beetles and the soldier bugs which feed upon the grubs. Intense heat in the summer and severe cold in winter also will destroy many of them. A spray of arsenate of lead, three pounds to 50 gallons of water, is the most effective method of controlling the pests. It may be well to add three pounds of resin soap to this spray in order to make it stick better. Such a spray should be applied as soon as the cutting is finished and repeated once or twice at intervals of ten days. Previous to this all shoots should be cut every few days, leaving no shoots upon which grubs can hatch and feed. Where this cutting is followed by spraying, there should be no trouble in controlling the pest.

CHAPTER XI

INSECTS INJURIOUS TO THE STRAWBERRY

I. THE STRAWBERRY ROOT-LOUSE. II. THE STRAWBERRY CROWN-BORER. III. THE STRAWBERRY LEAF-ROLLER. IV. THE STRAWBERRY WEEVIL.

THE STRAWBERRY ROOT-LOUSE

This insect was first known in Illinois in 1884, but has since spread to most of the states east of the Rocky Mountains. Its presence causes the plant to wither and die; frequently entire beds are ruined. Injury seems to be most serious on light sandy soil, and is rarely seen on heavy soils. Injury is also periodic, the lice may be present for two or three years and then disappear for some time. The strawberry is their only food plant. When bare spots surrounded by unhealthy plants are noticed in strawberry beds, we may suspect that the trouble is caused by the root lice, especially if we find ants in large numbers around the plants. If the lice are present, an examination will disclose them, small, dark green or black aphides, covering the roots and stems of the plants (See Fig. 16).

Life History—The winter is spent by these root lice in the egg stage. Small shiny black eggs may be found upon the stems and along the mid-ribs of the leaves. They are so small as to almost escape observation. Many of these are destroyed during the winter but those that survive hatch in April or May into young aphides which fight their way to the tender leaves of the crown. In about twelve days the aphides are mature and every one gives birth to fifteen or twenty more in a few days. Generation after generation composed entirely of females follow in quick succession throughout the summer. Soon after their appearance, the ants become active and carry the aphides down to the roots of the strawberry plants.

No aphid is ever found on the roots until the ants have appeared and their care extends throughout the summer. When one plant becomes overcrowded and dies, they carry them to a new plant. About the time of the third generation, some of the root lice appear with wings, thus providing for the further spread of the pest. As winter approaches males are produced and soon the eggs are placed on the stems and leaves of the strawberry plants, each female producing about four eggs.

Fortunately these root lice have certain parasitic enemies which are very efficient in controlling them. The parasites, which are little

four-winged flies, place their eggs inside the plant lice. The maggots live upon the tissues of the root lice and transform in their bodies to little flies. The dead, inflated shells of the root lice may easily be recognized, each one with a circular hole in its back through which the parasite has emerged.

Control—When starting a strawberry bed, be sure that you have clean plants and that the land is not infested. After infestation the aphides can be reduced in numbers by placing straw or grass upon the bed at just about the time the growth commences and burning this over quickly. At this time the eggs or young aphides are on the leaves



Fig. 16.—Strawberry root-lice clustered on small rootlets from crown of plant—greatly enlarged.

Courtesy of John Wiley & Sons

or stems and will be destroyed. Before setting, plants can be disinfected by dipping them for a few moments in dilute tobacco extract. As this will have no effect upon the eggs, planting should be held over and the disinfecting done after the lice are all hatched. Infested beds should be plowed up during the fall. A rotation, planting some other crop upon the infested land for one or two years, will be helpful.

THE STRAWBERRY CROWN-BORER

Strawberry plants are often attacked by small white grubs which eat out the center of the crown, thus dwarfing or completely killing

the plants. These are the grubs of a small dark snout-beetle about one-fifth of an inch long that can easily be recognized by three black spots on each wing-cover.

Life History—The beetles emerge from hibernation early in the spring and place their eggs between the base of the stems and the leaves of the strawberry plants. The grubs are full grown about midsummer. They pupate in the cavities which they have made in the crown of the plant and transform into beetles soon after. There is but one generation a year and old plants seem to be more frequently attacked.

Control—The wings seem to be of very little use to the beetles, so their spread is very slow. Frequent rotation and plowing up beds after one or two crops will prevent their spreading. Be sure to use uninfested plants when setting out new beds.

THE STRAWBERRY LEAF-ROLLER

Injuries from this insect are very periodic. It is never prevalent for more than a year or two, and even then is very local in its distribution. The adult is a small moth, measuring only about two-fifths of an inch with extended wings. It is reddish brown in color, the forewings streaked and spotted with black and white. The injury is done by the small green caterpillar folding up the leaves and feeding within the rolls. Many of the leaves are killed and become dry and brown. When badly infested the strawberry patch has the appearance of being scorched by fire. The injury to the foliage causes the fruit to become shriveled and dry and to ripen before maturity.

Life History—Eggs are placed by the moths on the surface of half-grown leaves during May. In about a week the caterpillars hatch and feed first of all on the upper side of the leaf, eating the mid-rib, thus cutting off the sap from the extremity of the leaf. Soon they begin to draw down the upper end of the leaf, fastening it down by little strands of silk and inside this folded leaf they remain and feed until pupation. Sometimes several caterpillars may be found in one leaf. The pupal stage is passed inside of a silken web spun inside the leaf and lasts about ten days. Nearly fifty days are required for the completion of the life cycle from the egg to the adult. The second brood, which appears in June and July, feeds more commonly on the blackberry and the raspberry. The winter is passed either as larvæ or as pupæ.

Control—Owing to the fact that the larvæ feed inside of the folded leaves, it is very difficult to reach them with a spray, but if spraying is applied as soon as the adult is noticed and again about a week later, the young caterpillars will be killed before they have begun to fold up the leaves. After the crop has been gathered, the beds can be

mowed and the leaves raked up and burned. Many concealed larvæ and pupæ are destroyed in this way.

THE STRAWBERRY WEEVIL

When we find buds of strawberries withering and their stems cut so that the buds drop on the ground, we may suspect the presence of the Strawberry Weevil (See Fig. 17, a b). The insect which is a true weevil, the head being prolonged into a long slender snout, is only about one-tenth of an inch long, and almost black or dull reddish in color with a dark spot near the end of each wing-cover. It is so small that it generally escapes detection. The weevil has been most injurious

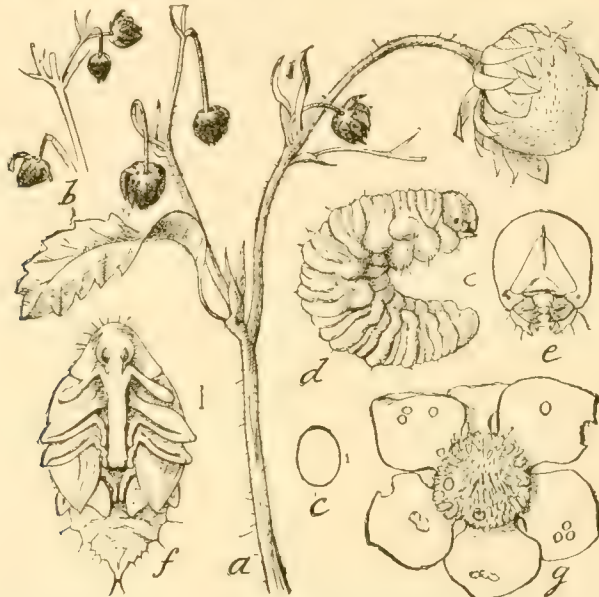

Fig. 17.—The Strawberry Weevil: a, b, Spray showing work in bud and stem—natural size; c, outline of egg; d, larva; e, head of same; f, pupa; g, bud opened to show egg on left and punctures made by snout of beetle through petals.

Courtesy of the Minnesota Experiment Station

to strawberries in the middle northern states, although present over a great part of the United States east of the Rocky Mountains.

Life History—The beetles emerge from hibernation early in the spring, a few days before the early flowers appear, and the greatest injury is done during the next few weeks. They eat holes around the outer covering of the nearly matured buds (See Fig. 17, g) and place their eggs inside. They then cut the stem of the bud so that it hangs downward and soon drops to the ground. This cutting of the stem prevents further development of the bud, and conserves the pollen upon which the young grubs feed. Dropping to the ground it remains moist and keeps the larvæ from drying out and dying. Six or seven days are required for the eggs to hatch and three or four weeks for

the grubs to reach full growth. The pupal stage requires five or eight days and is passed inside the forming bud. There is only one brood every season, the beetles going into their hibernating retreats soon after they emerge in the summer.

Control—As the larvæ feed upon the buds of the staminate varieties of the strawberry, it might be well wherever these insects are abundant to plant a few rows of the staminate varieties which flower freely to act as a trap crop. The beetles will deposit their eggs in the flower cups and the buds can then be destroyed by covering with straw and burning. As the beetles feed upon buds and leaves, an arsenate of lead spray destroys them. The spray should be applied with an underspray nozzle so as to cover the underside of the leaf as well as the upper side. Spray as soon as the buds begin to form and repeat a few days later. Destroy all rubbish about the fields in the fall, as the beetles hibernate in such material.

CHAPTER XII

INSECTS INJURIOUS TO RASPBERRIES, BLACKBERRIES, CURRANTS AND GOOSEBERRIES

- I. THE RASPBERRY ROOT-BORER. II. THE RASPBERRY CANE-BORER. III. THE SNOWY TREE-CRICKET. IV. THE RASPBERRY SAW-FLY. V. THE RASPBERRY BYTURUS. VI. THE IMPORTED CURRANT-BORER. VII. THE FLOUR-LINED LEAF-BUG. VIII. THE CURRANT APHIS. IX. THE IMPORTED CURRANT WORM. X. THE NATIVE CURRANT WORM.

THE RASPBERRY ROOT-BORER

These insects tunnel in the roots of the lower stems of raspberries and blackberries. The name blackberry crown borer has been given to them also because they sometimes girdle the stem at the crown. The injury is apt to be noticed in the early summer when vigorous canes suddenly wilt. The borer is a fleshy caterpillar, yellowish white in color with a brownish head. The adult insect is a moth which looks very much like a large wasp because of the yellow bands across its body and its wings, transparent except for a bronze border around the edges.

Control — Infested canes and roots should be pulled out and burned. This should be done in the spring.

THE RASPBERRY CANE-BORER

The Raspberry Cane-borer is the grub of a small beetle. The beetles are rather long and cylindrical, and of a deep black color except for the prothorax which is yellow bearing two or three black spots. They appear in the early summer and the females cut into young shoots by girdling two lines around them, and insert a rather large egg into the tissue between these two rings. The tips of the girdled canes wither and often bend over sharply. A slender grub hatches from the egg and burrows down into the pith of the cane. After a winter spent at the base of the cane, pupation takes place the following spring. Adults appear soon afterwards.

Control — Cut off the tips well below the point girdled and burn them as soon as they seem to be withered. Cut all dead canes in late summer and burn them.

THE SNOWY TREE-CRICKET

Long, ragged wounds (Fig. 19, a) will often be found in early spring in dead canes. If these are cut open, it will be found that the injury consists of a long series of minute punctures each containing an egg. These eggs were placed in the cane by the Snowy Tree-cricket (Fig. 18), a very delicate insect of a greenish or whitish color with transparent wings, very long antennæ and hind legs fitted for jumping. Its color protects it in its habit of living among the foliage of trees and shrubs, and has given it the name of Snowy Tree-cricket. The clear and shrill song, something like that of the katydid, which it pro-

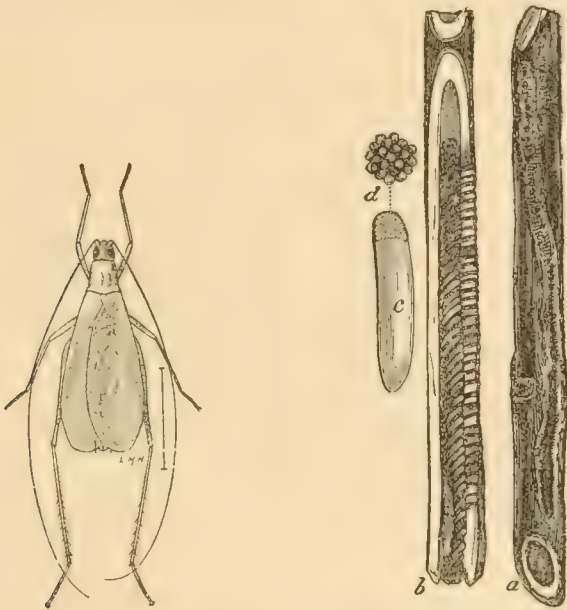

Fig. 18.—Snowy Tree-cricket, male, enlarged.

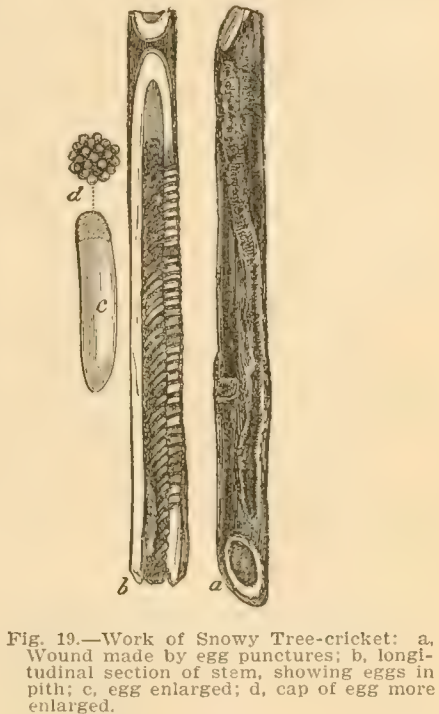

Fig. 19.—Work of Snowy Tree-cricket: a, Wound made by egg punctures; b, longitudinal section of stem, showing eggs in pith; c, egg enlarged; d, cap of egg more enlarged.

Courtesy of the Minnesota Experiment Station

duces in the evening is familiar to everyone. The species is widely distributed and its eggs are frequently found on the twigs of fruit trees, various woody weeds and stalks of cotton.

Life History—The eggs are placed in the raspberry canes in the autumn, hatching next spring. The nymphs and adults are not injurious; on the other hand they are almost considered beneficial, as they feed upon plant lice and other insects, only occasionally nibbling foliage. Late in the summer they are full grown. There is only one generation a year in the North, but in the South two generations.

Control—Examine the canes soon after the foliage starts. Cut

out and burn those which are infested. If not numerous they may be ignored.

THE RASPBERRY SAW-FLY

This insect is most commonly found in the eastern and central states. The injury is done by the larvæ skeletonizing the leaves of raspberry, blackberry and dewberry. This usually occurs in May; sometimes the plants are completely defoliated. The adults generally appear about the middle of May, inserting their eggs beneath the surface of the underside of the leaves. The presence of the eggs can soon be detected by the blisters or yellowish spots which appear around them. The young larvæ feed upon the tissue of the leaf for about ten days when they are full grown and drop down to the soil, remaining there in earthy brown cocoons until next spring when they transform into pupæ.

Control—A spray of arsenate of lead should be applied when the plants are beginning to flower. On light soil the larvæ can be jarred from the plants and then buried by running a cultivator over them. This is quite practical during warm weather as the heat of the soil will kill them before they can crawl back to the plants.

THE RASPBERRY BYTURUS

This is a small insect about one-seventh of an inch in length, and reddish brown or yellow in color. The beetles injure the plant by biting on the foliage and eating the flower buds. Sometimes they are so numerous as to do considerable damage in this way. In June they deposit their eggs and the larvæ feed on the white fleshy head which bears the berry. This causes the affected berry to be small and unfit for market, and to ripen earlier than the rest of the crop. Sometimes the grub remains in the cup of the berry, making it necessary to pick the berries over very carefully before they are saleable. Transformation takes place in the soil, the beetle not emerging until the next spring. The red raspberry seems to be the only variety affected.

Control—Spraying with arsenate of lead will kill the beetles while they are feeding on the foliage in the spring. The pupæ may be destroyed through cultivation in the spring.

THE IMPORTED CURRANT-BORER

This is undoubtedly the worst pest of the currant and gooseberry. The adult is one of the clear-winged moths and it is very similar in appearance to that of the raspberry root-borer. The moths appear in June, placing their eggs in the axils of the leaves, or under scales or in crevices of the canes. The young caterpillar burrows into the pith of

the canes and becomes half grown by winter. It hibernates in the bottom of the burrows and in the spring begins to feed again, becoming full grown by May, pupation taking place in the burrow. Canes which are eaten by these grubs look dwarfed and unhealthy and the foliage turns yellow. There is only one method of keeping the borers in check. All the old wood and infested canes should be cut out in the fall or early spring and destroyed.

THE FOUR-LINED LEAF-BUG

This is the most common of all the leaf beetles and although it has a long list of other food plants it often does considerable damage to the young foliage of the currant and gooseberry. The injury takes the appearance of a small brown burned spot on the tender leaf in early summer, later the leaf turns completely brown, curls up and becomes hard and brittle. The growth of the young shoot is checked and it frequently dies. The insect which causes this injury is a small bug of a greenish color with four black stripes and a black spot on the wing-covers. Both the adult and nymph obtain their food by sucking juice of the leaves. The eggs are inserted into slits, cut lengthwise in the stems of the plant, late in June or early August. In May or June of the next year these eggs hatch, the young nymphs feed upon the young leaves and are full grown in May or early June.

Control—The egg scars are easily seen and the tips containing them should be cut off and destroyed during the winter. Kerosene emulsion spray will kill the nymphs and the adults.

THE CURRANT APHIS

This aphid causes the curling of the leaf of currants and gooseberries in late spring. If the curled leaf is pulled open, it will be found to contain numerous tiny yellow plant lice.

The life history is practically the same as that of other plant lice. After passing the winter in the egg stage, the aphides multiply on the foliage until the middle of June when they become greatly reduced in numbers because of the attacks of parasites and predaceous insects or else they migrate to other food plants.

Control—Spraying with kerosene emulsion, tobacco extract or whale oil soap (one pound to six gallons of water), will kill the aphides. Spraying must be done, however, before the leaves are badly curled. Where there are only a few plants to care for, the curled leaves can be picked off and destroyed.

THE IMPORTED CURRANT WORM

This is the larva of the saw-fly which feeds upon all currants and gooseberries. Supposed to have been accidentally introduced into this

country in 1857, it has since spread to the greater part of the United States and Canada. The saw-fly places its eggs on the mid-rib of the leaf. From four to ten days later the egg hatches into a small whitish caterpillar with black spots on each side of the head. As soon as it begins to feed, however, the caterpillar becomes green in color and after the first skin is shed the head becomes black. At first the young worm skeletonizes the leaves but after they grow larger they eat everything except the mid-rib, often completely defoliating the entire bush. If this is allowed to occur for several years it will cause the death of the bush. When the worm becomes about three-fourths of an inch in length it goes down into the soil, spins a small silken cocoon just below the surface or in rubbish on the surface of the soil and pupates. Saw-flies emerge late in June or July. A second generation of worms follows but the adults of this generation do not appear until the next spring.

Control—See control of native Currant Worm.

THE NATIVE CURRANT WORM

This is not so destructive as the European species but it is widely distributed over the United States. It resembles quite closely the imported currant worm except that the worms are smaller and the cocoons are attached to the leaf or twigs of the bushes. There are two generations in the season.

Control—Before the fruit has set or after it is picked, spray the bushes with arsenate of lead or Paris green. Gooseberries should be sprayed with Bordeaux mixture to which arsenate of lead or Paris green has been added. This will help to control the plant worm which attacks the gooseberry. When in fruit the plant should be dusted with hellebore.

CHAPTER XIII

INSECTS INJURIOUS TO GRAPES

- I. THE GRAPE CANE-BORER. II. THE GRAPEVINE FLEA-BEETLE. III. THE ROSE-CHAFER. IV. HAWK MOTH LARVAE. V. THE GRAPE-BERRY MOTH. VI. THE GRAPE CURCULIO.

THE GRAPE CANE-BORER

Injury from this insect has been most severe in the Mississippi valley, although it is found eastward to the coast. It attacks the twigs of apple, pear, peach, plum and many forest, shade and ornamental trees, but the grape seems to be its favorite food. In the spring time the young shoots of the grape frequently break off or droop and die. Examination will show that an opening leads into the withered shoot at the base and that a burrow extends down into the main stem. Further investigation will reveal a brown beetle about one-half an inch long which has produced this tunnel. Its attack frequently results in killing all the new growth. This dying or partly dried condition of the stem seems to be necessary for its breeding. In old dry wood it will not breed, nor in vigorous live growth. The grubs mature in the burrows transforming into beetles in the fall, and remaining there until the following spring.

Control — Remove all diseased wood in the late spring, thus destroying the young grubs.

THE GRAPEVINE FLEA-BEETLE

About the time that the grapevine buds are swelling in the spring, little bluish or greenish beetles begin to attack them, eating out the center or entirely devouring them. They may frequently destroy all the buds on a vine, in this way retarding growth or killing the plant outright.

Life History —The eggs are laid in cracks of the bark at the base of the buds, or in the cavities in which the beetles have been feeding or sometimes on the foliage. These eggs hatch just as the young leaves are expanding, and upon them the small grubs feed. Large irregular holes are eaten out from the upper part of the leaves into the soft tissues beneath. After three or four weeks, these grubs drop to the ground, burrow one or two inches beneath the surface and transform into pupæ from which the beetles come in a couple of weeks. During

the remainder of the summer they feed upon the foliage of grapes and other plants but do no particular harm. Winter is passed by the beetles in hibernation.

Control—Little injury comes from flea-beetles when regular spraying with arsenate of lead is practised. In neglected vineyards they are liable to become very numerous and may do serious harm. If for any reason it is necessary to prevent injury to the buds in the spring the vines should be sprayed immediately upon the appearance of the beetles with arsenate of lead, eight pounds to a barrel of water. A day's delay of this spraying may mean the destruction of all the buds. Where only a few vines are concerned, the beetles may be shaken off early in the morning while they are still sluggish and destroyed.

THE ROSE-CHAFFER

The Rose-chaffer is a beetle about one-third of an inch long, light brownish in color, covered with numerous hairs, and having very long spiny legs. It belongs to the same group as does the June-bug which it resembles somewhat. The insect is a very general feeder but when abundant does considerable injury to the grapes. The beetles appear in large swarms about the time the grapes are in flower. First they feed upon the flowers, later on the young fruit and leaves, sometimes completely skeletonizing the leaves and deforming the fruit.

Life History—In June the eggs are laid by the female beetles in the soil, hatching in two or three weeks. The grubs resemble the white grubs which feed on the roots of various grasses. They are nearly full grown by autumn and pass the winter in the soil below the frost line. Near spring they work their way to the surface of the soil and pupate, the adults emerging soon after. There is but one generation a year and all the injury is done by the beetle during the short time it is abroad.

Control—There is no satisfactory method of controlling this pest. The beetles when abundant can be shaken from the vines into receptacles placed beneath, containing water and kerosene. Sometimes an umbrella-shaped frame covered with oilcloth can be placed in an inverted position under the vine and the beetles can be jarred into it. The apparatus slopes towards the center in which a receptacle is placed to hold kerosene oil. A thorough spraying with arsenate of lead, five to ten pounds to a barrel of water has been found to give good results, when the beetles are not too numerous. As the grubs feed upon the weeds and grasses, keep down all weeds in the vineyard. Clean cultivation will always reduce their numbers.

THE HAWK-MOTH CATERPILLAR

The caterpillars of several species of the hawk moth are found in the vineyard. The moths feed mostly on the grape vines. Usually

they are not numerous enough to do much damage. They are of large size and are readily seen, so they may be picked up and destroyed by hand.

THE GRAPE-BERRY MOTH

Wormy grapes represent the work of the Grape-berry Moth. The adult is a small purplish brown moth measuring one-half inch with wings expanded. The front wings are spotted with dark brown. The moths appear in the spring at the time the young grape shoots start growing. The first generation of the caterpillars feeds upon the blossoms, webbing them together, or upon the young fruit; later they bore into the green or ripening fruit, producing dark colored spots. The berries soon decay and fungous diseases set in, causing much injury. The caterpillars which are now full grown and of either a purplish or greenish color, cut out small pieces of the leaf on three sides. Folding over the cut area they spin their cocoons in these pockets. There are two or possibly three generations in a summer. The second generation also breed on the grape berries.

Control—Pick off and destroy all infested berries. Plow the vineyard in the fall or early spring, also turn under all the fallen leaves in which will be found the pupæ that pass over the winter. The best remedy is to spray with arsenate of lead, three pounds to a barrel of water before the blossoms open to kill the early caterpillars. A second spraying should follow when the grapes have finished blooming and a third in July. Resin soap should be added to the spray in order to make it stick to the berries.

THE GRAPE CURCULIO

The grubs of the Grape Curculio are also another cause of wormy grapes. The grubs can easily be distinguished from the caterpillar of the berry moth, however, by the fact that they are white, short, thick and footless. The adult is a small brownish snout-beetle, about one-tenth of an inch long. It is almost invisible, looking like a bit of dirt on the vine.

Life History—The winter is spent by the beetles in or close to the vineyard, particularly along the edge of woodland where there is plenty of rubbish in which they can hide. In the spring they feed upon the foliage of the grapes, cutting small characteristic holes, and in three or four weeks enter the berries. They are then about one-fourth grown. In July and August the eggs are deposited in the grape berries. Small cavities are hollowed in the berries and an egg is forced into each one, every beetle laying about 250. Infested berries show a purplish spot around the egg puncture. The grub burrows down reaching the seed in a few days, which it then devours. After

twelve or fifteen days it is full grown, and crawling out of the berry transforms to the pupa in a little cell which it makes among stones or lumps of dirt on the surface of the soil. In about three weeks the beetles appear. They then feed upon vines until fall when they enter hibernation.

Control—It is easy to kill the beetles by spraying with arsenicals in the early summer, when they are feeding upon foliage. Cultivation of the vineyard in midsummer when they are pupating will destroy many. Infested fruit can be collected and destroyed where spraying is followed out, other remedies are generally unnecessary.

CHAPTER XIV

SOME INSECTS INJURIOUS TO ORCHARD FRUITS

I. THE SAN JOSE SCALE. II. THE BUFFALO TREE-HOPPER. III. THE PERIODICAL CICADA. IV. THE FALL WEBWORM. V. THE BROWN-TAIL MOTH. VI. THE GYPSY MOTH. VII. THE CANKER WORM. VIII. THE PLUM CURCULIO. IX. THE PLUM GOUGER.

THE SAN JOSE SCALE

This is perhaps the most destructive of the scale insects attacking orchard trees. A great deal of labor is involved in keeping it in control, as spraying each year is necessary to accomplish this. It is a very small and insignificant insect in appearance, being a dark green or blackish color, and unless careful watch is kept it may increase so rapidly as to kill young trees in two or three years. Trunks and branches covered with this scale have a roughened, grayish appearance. To make sure the scale is present a thumb nail can be run over the surface and if the bark is infested, yellow drops of liquid will appear. The illustration (Fig. 20) shows the appearance of the female. If the scale is lifted with a pin, beneath it will be found a small, soft, orange colored object attached to the tree by long slender mouth parts through which it sucks up the sap. This is the real insect; the scale is merely a covering, excreted for its protection. The name of San José scale has been given to this pest because it was first discovered near San José, California, in about 1880. It was brought east on Japanese plum trees, secured by eastern nursery men in whose nursery it was first established. Eventually it has spread from these places on young trees to practically every state. The insect was probably brought to this country from China.

Life History—The scale insects are not full grown until early in the spring, at which time the small, almost microscopical males appear. Because of their small size and the fact that they fly only at night, these are almost never seen. In about a month the female insects begin to produce live young and continue to do so for about six weeks. They differ in this respect from most of the scale insects which usually produce eggs. The young insects move about quite freely, searching for a place to feed; in about a day they settle down, push their beaks through the bark, lose their legs and begin to excrete a waxy filament over the body. In a few days this completely covers the creatures and soon mats down into a scale-like form. They grow

very rapidly and are full grown in about a month. In the northern states there are about two generations in a season, but farther south the rapidity with which they reproduce is remarkable and it is to this enormous multiplication that the destructiveness of the pest is due. It has been estimated that in the vicinity of Washington, D. C., the descent of a single female would reach the enormous total of 3,216,080,400 by autumn if every one were able to survive. We can see therefore, how easy it is for a few scales to completely cover a tree and kill it in two or three years. This insect is spread from place to place



Fig. 20.—San José Scale: a, Natural size; b, enlarged.

Courtesy of the Minnesota Experiment Station

by the young scales being blown by the wind, carried on the feet of pedestrians and insects, or brushed off and carried by persons or teams working in the orchards. The long distant transportations which are the most serious have been brought about by the shipping of infested nursery stock. The insect is able to feed on a large number of plants but the greatest injury is done to deciduous fruits, such as peach, pear, Japanese plum, apple and quince. These are most injured in the order named, while the cherry and European plum are but slightly injured.

Control—The most practical method of control is a spray of concentrated solution of lime-sulphur in the proportion of one gallon to

eight or nine gallons of water. This should be applied while the trees are dormant. Trees which are badly infested should be sprayed in the early winter as soon as they are hardened up. The second spray should be applied in the spring when the buds are beginning to swell. If this second spraying has not been applied it is necessary to do something in the summer. Spraying with commercial lime-sulphur in the proportion of one gallon to thirty gallons of water may be effective. On the Pacific coast the trees are fumigated with hydrocyanic acid gas, but this system is not used in the East.

THE BUFFALO TREE-HOPPER

The Buffalo Tree-hopper is one of the insects which we often call "brownie bugs." It is of a grass green color about three-eighths of an inch long with the forepart of the body expanded into two sharp horns, projecting immediately above the eyes; this has given rise to the term buffalo tree-hopper. The thorax is also extended into a long pointed projecting covering of back and wings. These hoppers are extremely common, feeding upon all sorts of midsummer vegetation. Like others, they take their food by sucking the sap through their long beaks. The injury which they do is very similar to that of the tree-cricket but the scars are much larger and are placed irregularly, every slit being more or less semi-circular in outline with the convex sides of each pair facing each other. The twigs of fruit and shade trees are sometimes so thickly set with these scars as to become badly stunted or even killed.

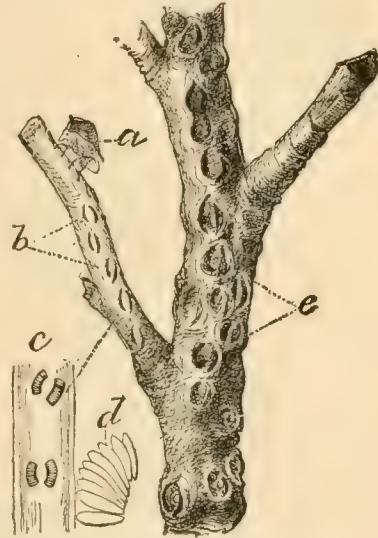

Fig. 21.—The Buffalo Tree-hopper and its Work: a, Adult; b, fresh egg slits; c, eggs in slits, natural size; d, eggs enlarged; e, scars produced by egg slits.

Courtesy of the Minnesota Experiment Station

Life History—The eggs are placed in the twigs from October until frost, six to twelve in each slit. In placing the eggs the female cuts the bark between the slits entirely loose, killing quite large areas and thus protecting the eggs by preventing further growth of the wood. The eggs do not hatch until next spring. Injury to the trees consists entirely of these egg scars, as both the young and adults feed upon succulent vegetation, and seem to prefer the weeds that grow in the orchards.

Control—If orchards are cultivated and kept free from weeds, the young tree-hoppers will be starved out. Twigs containing the egg punctures should be pulled off and burned during the winter.

THE PERIODICAL CICADA

This insect is frequently called the Seventeen-year Locust. When outbreaks occur, people will frequently say it is the reappearance of the locust. It is in no way related to our locust and grasshoppers but the fact that it appears in huge swarms has given it the popular name of seventeen-year locust. It is placed with the group of sucking insects which feed by sucking the juice of plants through their sharp tube-like beaks, whereas the grasshopper feeds by biting off the chewing portions of the foliage plants.



Fig. 22.—Cicada or Harvest Fly.

Life History—This insect has attracted more attention probably than any insect in this country because of the peculiarity of its life history. So accurate has been the observation on this insect that its appearance is forewarned many years ahead. In the different parts of the country twenty-two “broods” have been distinguished, thirteen of these appearing in the North at seventeen-year intervals, and seven in the South, at thirteen-year intervals. Every year one of these broods emerges in some part of the country. The adults (See Fig. 23) usually appearing in late May or early June; in about four or five days the male begins to sing, cutting the air with its deafening, shrill song. A couple of weeks later the females begin to deposit their eggs, making huge, ragged slits in the branches of shrubs and trees into which the eggs are thrust. Each female is said to deposit from three to five hundred eggs. These hatch in six or eight weeks and the nymphs drop down to the ground into which they burrow. They remain in the ground for seventeen years (in the South, thirteen), sucking the juice from the roots of the plants, possibly getting some nutriment from the soil itself. Early in the spring of the seventeenth year they begin to make exit burrows and galleries to the surface of the soil. These burrows are kept open from a depth of a few inches to a foot or more and in clay soil are surmounted by chimney-like structures, extending four or five inches high. The nymphs come forth in the evening, and crawl to the nearest tree, the side of a building, fence or other upright object. Soon their skin splits down the back and the adult insect emerges. During the adults’ life they feed very little if any at all. The injury done consists entirely in the wounds they make when depositing their eggs under the bark of trees. These wounds cause the twigs to dry and often they appear as if they had been burned.

With the cultivation of the land and removal of forests, the cicada has become more scarce.

Control—It is necessary to know in what section this insect is found. This information can be secured in bulletins published by the Federal Government. When it is known that the cicadas will appear the following year, orchards should not be pruned. After the eggs are laid, the affected twigs should be cut out in July and burned before the eggs get a chance to hatch.

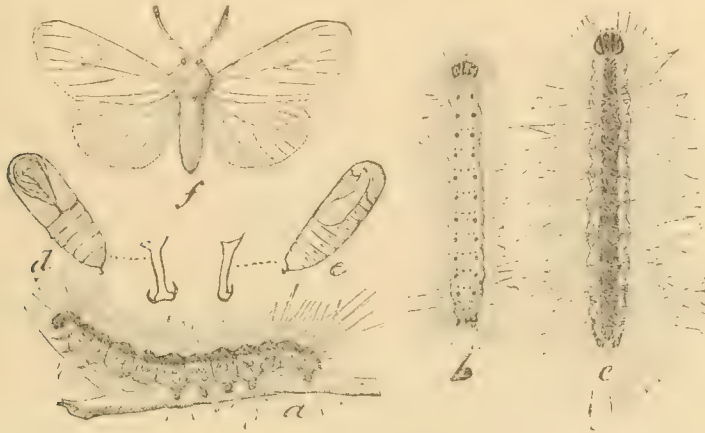

Fig. 23.—Fall Webworm: Caterpillars, Pupae, and Moths.

Courtesy of the Wisconsin State Entomologist

THE FALL WEB-WORM

This insect should not be classed with the tent caterpillar. The webs of the tent caterpillar are found in the spring whereas those of the fall webworm are abundant in August and September. The caterpillars of this insect are about one inch long, with long black and white hairs projecting from black tubercles on the body (Fig. 23).

Life History—The moths appear late in June and July, placing their eggs on the leaves of orchard and shade trees in masses of four to five hundred. The eggs are pale yellowish green and hatch in about ten days. The caterpillars from one mass of eggs feed together and immediately begin to spin a silk web over the leaves upon which they are feeding (Fig. 24). As soon as they have devoured the foliage on one limb, they leave their nest and build a new one on another branch, so that several webs may be seen on a tree at the same time. It requires from four to six weeks before the caterpillars are full grown and they then hide under the bark of the tree or among rubbish at its foot or even in the soil, spinning cocoons of silk mingled with the hairs from their own bodies. Pupation takes place in the fall but the moths do not appear until the next spring.

Control—Usually the parasites control these insects quite successfully but where very abundant they should be sprayed with arsenicals when the work of the young caterpillars is first noticed.

THE BROWN-TAIL MOTH

The Brown-tail Moth is confined to the New England States, to Massachusetts, New Hampshire and Maine, but there is a possibility of its extending to other parts of the United States. It received the

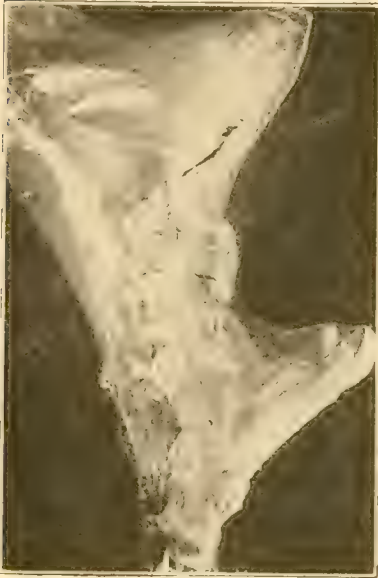

Fig. 24.—Web of Fall Webworm.
Courtesy of the Wisconsin Experiment Station

name of brown-tail moth because the abdomen of the adult is a golden brown and bears a large tuft of brownish hair. The rest of the body and wings of the moth are white. The caterpillar is one and one-fourth inches long, dark brown in color with white spots on the side of each segment. Numerous tubercles bear long barbed hairs which cause a very irritating rash on the skin of some people. The caterpillars will feed on almost every tree except evergreens but they seem to prefer fruit trees, such as apple, wild cherry and pear.

Life History—In midsummer the moths begin to appear. They are good fliers and are easily carried from place to place, frequently being driven by the winds for many miles. In summer the eggs are placed upon the leaves of terminal plants. The caterpillars feed upon the surface of the leaf, those from one egg mass remaining together somewhat like the fall webworm. They draw together the leaves with silken threads and by the time of the first frost have made this web very tough and strong. From a distance it looks like two dead leaves drawn together but if they are pulled apart there will be found inside numerous small pellets of silk each containing several little caterpillars partly grown. When the buds begin to burst in the spring the caterpillars come out and feed on the young foliage, becoming full grown in five or six weeks. Cocoons of thin silk are spun among the leaves, in which they pupate, and in three weeks the moths come out.

Control—As soon as the eggs hatch in late summer, trees may be sprayed with arsenate of lead, four pounds to fifty gallons of water; this will destroy the caterpillars before they spin their winter webs.

The winter nests can be pruned off and burned during the winter. Spraying is probably the better course as the repeated pruning often injures the trees.

THE GYPSY MOTH

The Gypsy Moth is an old pest on the other side of the world, found abundantly throughout Europe, most of Asia and South Africa. It is chiefly injurious in eastern and central Europe. In 1869 Professor Trouvelot while carrying out experiments in silk producing brought this insect to his laboratory. Some of the moths escaped into the

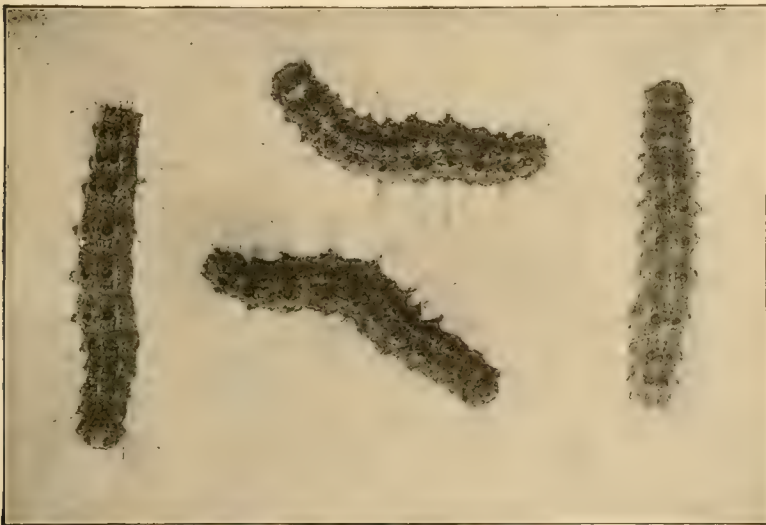

Fig. 25.—Gypsy Moth Caterpillars—natural size.

Courtesy of John Wiley & Sons

nearby woodland and were able to hold their own, increasing gradually for several years. By 1890 they had become so numerous as to be a serious pest in that vicinity, and the state of Massachusetts undertook the task of exterminating them. For ten years the fight was kept up and the insect was not able to spread beyond its original limits, but for the four years following no provision was made for the work, and during that time it spread over an area at least four times the size of the original. State action was again found necessary and appropriations for its control were also made by the Federal Government. The total cost of combating it now amounts to over a million dollars a year. In spite of this it is still increasing and its spread to other parts of the United State is entirely probable.

Life History—The female gypsy moth is rather large, being about two inches across with its wings spread. It is of a whitish color with numerous black markings, and so heavy of body that it is unable to fly. The male moth is of a brownish yellow or greenish brown color with darker stripes on the wings. It has a slender body and is smaller than the female, being only about one and one-half inches across the spread wings. The moths do no damage and live but a short time after maturing. The caterpillars (Fig. 25) are of a dusky or sooty color with a double row of five blue spots extending down the back followed by a double row of six red spots. Numerous long hairs extend from the body. The female lays from four hundred to five hundred eggs in July or August, placing them in irregular oval masses on the bark of trees or other protected places and covering them with yellow hairs from her body. The eggs remain until the next spring when they hatch and the caterpillars become full grown by summer. This



Fig. 26.—The Canker Worm
Courtesy of the Wisconsin Experiment Station

insect spreads mostly in the caterpillar stage; their long silken hair and the silk they spin out helps to buoy them up and they are blown by the wind. They also drop down on fine silken threads in great numbers and are carried away by pedestrians, or horses and wagons passing by. The egg masses may also be carried about on nursery stock or on merchandising or in boxing, into which the caterpillars have crawled when making their cocoons. Although naturally a pest of the forest trees, the caterpillars will attack any of the fruit or shade trees, and

when very abundant will feed upon any green vegetation.

Control—While the full grown caterpillar will feed upon most any tree, the young caterpillars are unable to feed upon conifers for some time after hatching, so cutting out all hardwood trees will soon starve out the insects. The trees may be sprayed with arsenate of lead, four pounds to fifty gallons of water, at the time the eggs are hatching in the spring. The shade or forest trees are hard to protect and if affected the owner should write to the United States Department of Agriculture, Bureau of Entomology, for advice.

CANKER WORMS

The Canker Worms are among the most common of the loopers or measuring worms which defoliate the trees in early spring. The caterpillars are easily recognized by the looping gait which they follow when moving about.

Life History—There are two species of this insect pest known as the spring canker worm and the fall canker worm from the time of their occurrence. The moths are very similar in appearance in both cases, the females of the first generation being wingless. Both species climb up the trunks of trees where they place their eggs under loose scales of bark and in crotches of the limbs.

Control—They can easily be controlled by placing bands of tree tangle-foot around the trunks of the trees in the spring and fall. Thorough



Fig. 27.—The Plum Curculio.

Courtesy of the Minnesota Experiment Station

cultivation of the soil in old sod orchards will destroy the pupæ in summer. The caterpillars can be killed by arsenical sprays.

THE PLUM CURCULIO

The Plum Curculio is perhaps the worst enemy of stone and pome fruits throughout the United States, east of the Rocky Mountains. The grub is the common white worm which we find inside of such fruits. Apples and cherries are also frequently scarred by the feeding and egg punctures of this insect. The adult is a thick-set snout-beetle of a dark grey or brownish color with four heavy ridges on the wing

covers. The head is prolonged to a snout about one-fourth of an inch in length. It is a native of the United States.

Life History—The winter is spent in hibernation in grasses and leaves on the ground in or near the orchard. Just before the fruit begins to bloom the beetle comes out and feeds upon the unfolding buds and blossoms. When the young fruit is set, they continue to feed upon that and the females soon place their eggs in the fruit. After the eggs have been deposited in little cavities the female cuts a crescent-shaped gash about them on one side, apparently for the purpose of retarding the growth of the fruit, so that it may not crush the egg. This crescent-shaped cut has given the name of "little Turk" to this insect.

The female may live about two months and during this time may deposit from one hundred to two hundred eggs. The young grub bores into the fruit until full grown. In stone fruits it usually feeds



Fig. 28.—Plum Gouger (greatly enlarged) with drawing of plum pit, showing hole made by the insect in leaving.

Courtesy of the Wisconsin Experiment Station

close to the pit. When matured it leaves the fruit and enters the soil in which it pupates, the adult emerging in three or four weeks and feeding upon the ripening fruit. The beetle hibernates over winter. The feeding punctures made by the adult in the fall cause more injury to the apple than those made in the springtime. The surface of the fruit is gnawed and openings are made for decay, rendering the fruit unfit for market. Injured stone fruits drop to the ground or if they remain on the tree ripen prematurely and rot quickly. In the case of apples the larvæ develop only in the fallen fruit.

Control—By far the most satisfactory method of control is by spraying with arsenate of lead to poison the beetles while eating. The first spray should be applied just before the flower buds open, the second just after the petals have fallen and the fruit set, and a third about two weeks later. The arsenate of lead should be used in the proportion of three pounds to fifty gallons of water, if the paste is used, and about half of that amount if the powdered form is used.

THE PLUM GOUGER

This insect is common throughout the Mississippi Valley being a native species breeding upon wild plums and common to all varieties.

While the work of the beetle might be mistaken for that of the plum curculio, the adults are quite different, lacking the heavy ridges on the wing-covers.

Life History—The beetles pass the winter in hibernation, appearing in the spring at about flowering time. They puncture the calyx and feed upon the ovary of the flower, completely destroying it. Later they feed upon the growing plum. Eggs are laid in punctures in the fruits while the stone is still soft. The grub works its way down into the pit and feeds upon the meat of the seed. Transformation takes place inside the pit, the beetle emerging a little before the plums are ripe. Fruit which has been badly punctured becomes gnarled and is quite worthless. After feeding a while the beetle goes into winter quarters.

Control—The only successful method of control has been to jar the beetles from the trees onto a canvas sheet and destroy them.

CHAPTER XV

INSECTS INJURIOUS TO APPLE AND PEAR

- I. THE WOOLLY APPLE-APHIS. II. THE ROUND-HEADED APPLE-TREE BORER. III. THE FLAT-HEADED APPLE-BORER. IV. THE OYSTER-SHELL SCALE. V. THE SCURFY SCALE. VI. APPLE PLANT-LICE. VII. THE TENT CATERPILLAR. VIII. THE YELLOW-NECKED APPLE CATERPILLAR. IX. THE RED-HUMPED APPLE CATERPILLAR. X. THE APPLE LEAF-MINER. XI. THE PISTOL CASE-BEARER AND THE CIGAR CASE-BEARER. XII. THE BUD MOTII. XIII. THE CODLING MOTII. XIV. THE APPLE MAGGOT OR "RAILROAD WORM." XV. THE PEAR SLUG.

THE WOOLLY APPLE-APHIS

This is a very destructive insect, especially to young trees. The aphides live mainly upon the roots where it is very hard to find them, and their presence often escapes detection. They are of a bluish white color, and covered with a white cottony mass which they give off from their bodies. They are often found on water-sprouts, and around wounds or scars on the trunk or limbs; and their presence in such places always indicates more upon the roots. In large numbers they do great damage, forming gall-like swellings on the roots and sapping the life of young trees till they become sickly and die, or fall easy prey to other enemies. The pest has been distributed over most of the world on nursery stock.

Life History—In spring the plant lice migrate from the roots to the upper part of the trees and there increase throughout the summer. When mature each female will produce two to twenty young every day. In the fall, winged aphides are produced which migrate to other trees. These winged forms produce wingless males and females which mate and each female lays one large black egg in a crevice of the bark near the base of the trunk. In the spring these eggs give rise to new colonies, which afterward find their way to the roots. As fast as one root is killed they move to younger ones; so that finding the swollen dead roots free from lice does not mean that the lice have left the plant, but merely that they have moved to other roots.

Control—Tobacco dust applied about the roots and trees kills the aphides and also acts as a repellent. Kerosene emulsion, whale oil soap, one pound to six gallons, or tobacco extract, or black leaf, one pint to seventy pints of water, used as a spray on the trunk and foliage will destroy the aphides. The spray must be applied with considerable force and thoroughness in order to make it penetrate the cottony

covering of the lice. A spray of lime-sulphur wash destroys the hibernating aphides on the trunk.

THE ROUND-HEADED APPLE-TREE BORER

This is a very common pest on trees east of the Rocky Mountains. Infested trees indicate the presence of the borer by retarded growth, yellowing of the leaves and sometimes by the sawdust which has been thrown out by the burrowing larvæ. In spring there is an exudation of sap from the entrance of its burrow. The adult is a very beautiful beetle of a brownish color with two longitudinal stripes on the upper part of the body, while the under surface is silvery white in color. The larvæ is a large cylindrical yellowish grub about three-fourths of an inch long, with a small head and an enlargement of the thorax which gives it the name of round-headed borer.

Life History—The beetles emerge from late May to early July and place their eggs in little slits in the bark. The eggs hatch in two or three weeks and the young larvæ tunnel just beneath the bark in the sap-wood, working toward the base of the tree. They continue their work in the sap-wood the second season. At this time the greatest injury is done. They may be so numerous in the tree as to almost or completely girdle it. In the third season they work into the heart-wood and transform into pupæ in the spring. The adults emerge in about three weeks.

Control—The trees may be protected by wrapping the trunk with heavy building paper or wire netting, early in May. This covering should extend a few inches into the soil and should be tied tightly to the top of the trunk. It should be held out from the trunk by a layer of cotton batting under it at the upper end. This protection should remain upon the tree until late summer. Whale oil soap, to which one pint of crude carbolic acid is added to every ten gallons, is often painted over the tree in a thick coat. This repels the beetles but does not destroy the larvæ. It is possible to cut the latter out from their burrows in the sap wood before much injury has been done to the tree. Where a tree has been nearly girdled, bridge-grafting may sometimes save it. Orchards kept free of grass and weeds are not so liable to be affected.

THE FLAT-HEADED APPLE-BORER

While this insect is more abundant than the round-headed borer it does less damage. It seems to prefer trees which have already been weakened for some reason. The beetle is a flattened, wedge-shaped brownish colored insect, about one-half inch long. The grub is more slender than that of the round-headed borer and the thorax is wide and flatter, giving it the name of flat-headed borer. It works just

beneath the bark hollowing out shallow channels in the sap-wood and may sometimes girdle young trees. Its presence may be detected by the discoloration of the bark.

Life History—The life history is similar to that of the round-headed borer, except that only one year is required for the growth of the larvæ. It does not pupate, however, until the next spring. Its burrows may be easily told from those of the round-headed borer by the shape of the exit holes. The round-headed borer emerges through a circular hole while that of the flat-headed is elliptical in shape. Well kept orchards of healthy trees will seldom be damaged by it.

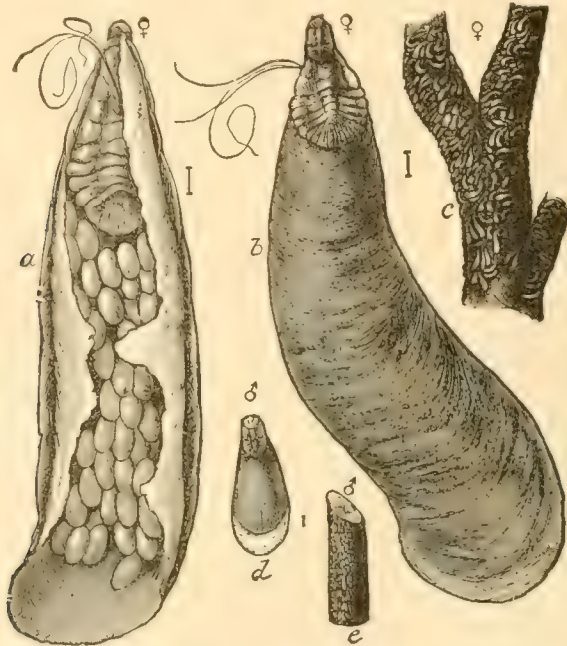

Fig. 29.—The Oyster-shell Scale: a, Female scale from below, showing eggs; b, same from above; c, female scale on branch; d, male scale—all greatly enlarged.

Courtesy of the Minnesota Experiment Station

THE OYSTER-SHELL SCALE

This is the most common scale in the northern states and is very fond of apples and pears, though it will also attack poplars and maples. When very abundant it frequently kills young trees. It is about one-eighth of an inch long, dark brown in color and about the shape of an oyster shell (Fig. 29). It will be found incrusting on the twigs and bark of young trees particularly.

Life History—Examination in the winter will disclose a large number of whitish eggs underneath the scale. These eggs hatch soon after the apples bloom into small yellow maggot-like insects which

travel around very actively for a few hours. As soon as they settle down they begin to suck the sap through the bark, and give off a waxy secretion which forms the scale over their backs. The female insect never moves again. It requires from eight to ten days for her to reach maturity; whereupon she deposits from forty to one hundred eggs upon the tree and dies. The male when full grown emerges from the scale as a tiny winged fly, fertilizes the female and dies.

Control—See Scurfy Scale below.

THE SCURFY SCALE

This scale is not as serious a pest as the oyster-shell. The female scale is irregular in shape and of a dirty gray color. The male scale is much smaller and more elongated. They infest the common fruit trees and are sometimes found on currant and gooseberry bushes.

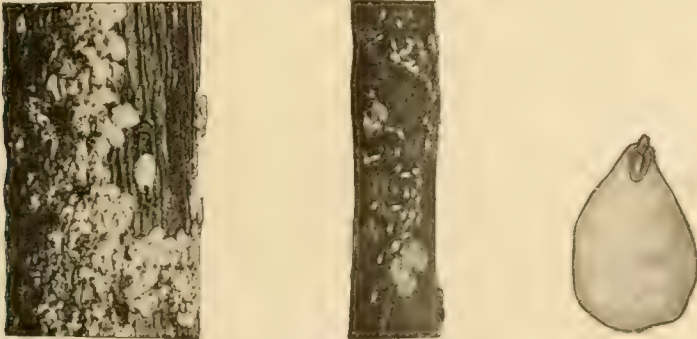

Fig. 30.—Scurfy Scale; large twig badly infested with female scale; small twig shows males which are smaller than females; drawing at right shows female greatly enlarged.

Courtesy of the Wisconsin Experiment Station

Life History—The life history is practically the same as that of the oyster-shell scale.

Control—These last two species may be controlled by spraying with commercial lime-sulphur wash, using one gallon to nine gallons of water. The spray should be applied after the trees have become dormant or just before the buds open. This spray has no effect upon the eggs but will kill the young soon after hatching.

APPLE PLANT-LICE

There are several species of small soft bodied sucking lice commonly found on the foliage of apple, pear and related trees. Their presence may be noticed first on the young shoots which are found covered with the tiny green or pink aphides. They cluster on the under side of the leaves causing them to curl and drop. Badly infested trees may lose nearly all their leaves in this way. Young trees are more particularly liable to attack. The fruit is not so apt to be damaged unless

the lice are very abundant; in such years the fruit even of old trees will be stunted and misshapen.

Life History—Their general life history is similar to that of other aphides. They winter over in the egg stage on the twigs of their food plants. As the leaves begin to unfold in the spring these eggs hatch and the lice feed upon the tender foliage, maturing in the course of ten days or two weeks. These females then bring forth living young without the intervention of any males which in turn when mature give birth to more females and so on throughout the summer. With each



Fig. 31.—The Apple-aphis; a, young tree partially defoliated by aphides; d, winter eggs on twigs.

Courtesy of John Wiley & Sons

generation there are a few winged females which fly to other food plants. The last generation in the fall consists of both males and females, and the latter lay eggs to preserve the species through the winter. The lice are attended throughout the summer by ants and numerous ants climbing the trunks of the trees indicate the presence of the aphides.

Control—The best means of control is to spray while the trees are dormant with commercial lime-sulphur, using the proportion of one gallon of the solution to eight gallons of water.

THE TENT CATERPILLAR

In the spring the leaves of apple, cherry and other trees are badly eaten by the Tent Caterpillar. Its presence can be identified by the large webs that the caterpillars place in the crotches of the trees. They never cover the leaves as do the webworms and by this distinction the two pests can be told apart. The moths are small stout-bodied insects of reddish brown color. The caterpillars are about two inches long, very dark in color with a white stripe down the center and a row of blue dots on either side. They are sparsely covered with yellow hairs.

Life History—The moths appear in July about five or six weeks after apples have bloomed. The eggs are placed in a band about the



Fig. 32.—Egg Mass of Tent Caterpillar.



Fig. 33.—Tent Caterpillar and Web.

Courtesy of the Wisconsin Experiment Station

twig and covered with a varnish which protects them from the winter weather. There are about two hundred eggs in each of these masses and the caterpillars hatch next spring, just when the leaves are expanding. The wild cherry and apple seem to be their favorite food and these trees are sometimes stripped bare year after year. All the common fruit trees are subject to attack and occasionally the shade trees. The caterpillars spin a web in the nearest crotch of the limbs and this is gradually enlarged with new layers of silk as the caterpillars grow. Here they spend the nights and cold wet weather, only coming out on pleasant days to feed. In five or six weeks they are completely grown and begin to move away from the trees in search of a place to spin their cocoons. Loose bark, fences, grass, rubbish or the sides of a building, furnish the places which they want and here

the cocoons are spun. About three weeks later the adult moths appear again. There is only one generation in a year.

Control—There are many natural enemies in way of insects, birds and bacterial diseases which hold these tent caterpillars in check. During the winter the egg masses may be easily seen and removed. The webs may be burned out on cloudy spring days or sprayed thoroughly with kerosene. No wild cherry or neglected apple trees should be left near the orchard. Arsenical sprays if applied soon after the foliage begins to appear will destroy the caterpillars.

THE YELLOW-NECKED APPLE CATERPILLAR

This caterpillar is about two inches long, with a jet-black head and the next segment, sometimes called the neck, a bright orange yellow, black and yellow stripes run alternately down the middle of its back. The body is thinly covered with long soft white hairs. This pest is present during the late summer and completely defoliates the branches. They usually feed in colonies and may often be found clustered together in masses upon the branches. When disturbed they throw up their heads and tails with a very characteristic and threatening manner. Winter is passed as pupæ in the soil. The brownish moths appear in June and July and deposit their eggs on the leaves of trees. There is but one generation a year.

Control—A spray of arsenate of lead, four pounds to fifty gallons of water, about the first of August is usually beneficial. As the colonies are very easy to see, hand-picking or spraying with kerosene will destroy them.

THE RED-HUMPED APPLE CATERPILLAR

This insect has been named from the prominent hump on the fourth segment of the body. This with the head is a bright red color, the body is striped with yellow and dark brown, and a double row of black spines extends along the back. It is found throughout the greater part of the United States feeding in late summer on orchard foliage. Plum and apple are its favorite fruit. Its life history is practically the same as that of the yellow-necked caterpillar. Control measures are practically the same.

THE APPLE-LEAF MINER

The Apple Leaf-miner injures the leaves of the apple by burrowing between the two surfaces, producing trumpet shaped blotches. It is a very serious pest. The larva is only one-third of an inch long and the adult moth about the same length over its extended wings.

Life History—The moth deposits its greenish yellow, blister-like

eggs on the surface of the leaf. In eight or ten days these hatch and little caterpillars work directly down into the leaf. Three weeks are required for them to become full grown. The pupæ are formed in the mines in the leaf and the state lasts from eight to ten days. The caterpillars of the last generation line their mines with silk and pass the winter in them, pupating and transforming into moths the following spring.

Control—As the larvæ pass the winter in the fallen leaves these should be plowed under in late fall or early spring, or they should be raked up and burned. A spray of kerosene emulsion will kill the larvæ in their mines in the summer if much damage is threatened.

THE PISTOL CASE-BEARER AND THE CIGAR CASE-BEARER

These insects are very similar in their life history. The caterpillars live in little cases which they make about them while feeding upon the foliage. They burrow into the substance of the leaf much the same as the leaf miners, but do not entirely leave their cases while doing so. They have been known to do great damage, occasionally defoliating entire orchards. The caterpillars winter in their cases which they have attached to twigs near or above the buds.

Just before the buds begin to swell they become active and feed upon the growing buds, later eating their way into the young expanding leaves. As they grow they enlarge their cases which assume the shape characteristic of the species. Those of the pistol case-bearer resemble an old-fashioned pistol, the butt being at the upper end, and those of the cigar case-bearer, being more or less trunky in shape, bear some resemblance to small cigars. As the caterpillars become larger they may devour the entire leaf, also attacking flower buds. When they are ready to pupate, the cases are attached firmly to the twigs. The pupation stage lasts ten to twelve days and the moth of the pistol case-bearer appears in June while that of the cigar case-bearer is a month later. Both moths are tiny grayish insects, measuring only one-half inch with wings expanded.

Control—A spray of Paris green or arsenate of lead just before the buds open and repeated as soon as the leaves are out will destroy the caterpillars.

THE BUD MOTH

This insect was first introduced from Europe, but has now spread throughout the northern and middle states, and as far west as Oregon and Idaho. The caterpillar attacks the buds of the apple, pear, and sometimes cherry, peach, plum or even blackberries, but seems to do most injury to the apple. The caterpillar is about one-half inch long, brown

in color with a darker head. The moth has a wing expansion of about five-eighths of an inch and is brown or gray, with a band of yellow across each fore-wing.

Life History—In the autumn the caterpillars form small cocoons upon the bark of the twigs where they spend the winter. In the spring they eat their way into the opening buds; later they fasten together the leaves, forming small nests, inside of which they feed upon the leaves and flower buds. Transformation takes place in June or July and the moths emerge in about ten days to lay eggs for the next brood of caterpillars. This second generation feeds upon the under surface of the leaf, spinning a thin web of silk for covering. In the fall the tiny worms migrate to the twigs and spin small silken cocoons in which they spend the winter.

Control—A spray of arsenate of lead applied just when the buds are bursting and repeated before the flower expands will destroy the caterpillars.

THE CODLING MOTH

Everyone is familiar with the small whitish worm which we find in apples. It is the larva of the codling moth and probably the best

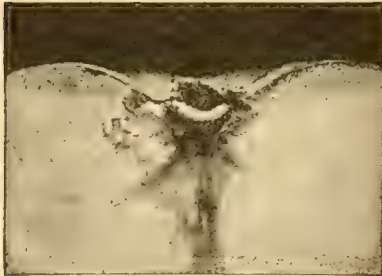

Fig. 34.—Larva of Codling Moth.
Courtesy of John Wiley & Sons

known and most destructive of apple pests. It is a native of Europe but is now distributed over the whole world where apples are grown. Most of the injured fruit falls to the ground and it is difficult for a grower to estimate the amount of damage he suffers from this pest. It has been estimated that a loss of \$12,000,000 may be attributed to it every year in the United States.

The adult moth is of a somber, grayish brown color; when examined close it seems to be crossed by numerous lines of gray and brown scales. As it flies only at night it is very rarely seen.

Life History—The winter is spent by the larvæ in small white cocoons beneath or in crevices of the bark. About the time the apples are in bloom, they pupate and the moths emerge two or three weeks later. The females place their eggs on the foliage and young fruit, each one depositing from sixty to seventy-five eggs. The eggs are very small, at first white and blister-like, but later turning brownish or black. Most of the eggs hatch in two or three weeks after the blossoms fall, and the young caterpillars feed first on the tender buds of the leaves before crawling to the nearest apple which they enter, usually through the blossom end. There they spend three or four weeks, feasting gen-

erally on the seeds of which they are very fond and at the end of that time when they are full grown, they leave the apple through a passage gnawed to the side and seek a suitable place for spinning their cocoons. These will be found usually on the trunk of the trees. Here they may remain until spring, but in the central and southern states the moths may hatch in ten or twelve days to lay another generation of caterpillars. The work of the second generation differs from that of the first, for the larvæ often feed merely on the surface of the apple without boring to the core.

Control—The best method of controlling this insect is by the use of insect sprays, which will destroy practically all of the larvæ. Four pounds of arsenate of lead to fifty gallons of water should be used. Two sprayings are necessary, the first one after the petals have fallen before the calyx cups have closed, in order to fill the flower cup with poison so the young worm which enters it will be killed before it is able to eat its way into the apple. The second spray should be applied in eight or fourteen days after the first so as to keep a film of poison on the fruit. Where two broods occur in a season, a second spray should be applied at the appearance of the second brood.

THE APPLE MAGGOT OR "RAILROAD WORM"

- While this insect is found as far west as Minnesota it seems to confine itself mostly to the New England States. The small white maggots burrow through the flesh of the apple in many directions, leaving discolored streaks through it. When they are very abundant, an apple which appears perfectly sound on the exterior will be found quite "railroaded" and destroyed on the inside. The sweet and subacid varieties of summer and early fall apples seem to be the most injured. The parent of the maggot is a small fly, not quite the size of a house-fly and with the wings distinctly marked by four black bands. In July the eggs are laid one at a time on the surface of the apple. The maggot feeds in the pulp completing its growth after the apple has fallen. It then bores its way out and enters the ground where it forms a pupa and remains till the following July.

Control—The affected fruit usually drops to the ground. It should be picked up and destroyed twice a week in summer, and at the end of the week in the fall, so as to prevent the worms from escaping and entering the soil to pupate. Hogs or sheep may be pastured to feed upon the fallen apples. Chickens will pick up the larvæ on bare ground.

THE PEAR SLUG

These small slimy insects work upon the foliage of pear, cherry and occasionally plum trees, eating off the outer surface of the leaves. The

adult insect is a small saw-fly, about one-fifth of an inch long, of a glossy black color. It is an old European insect which was introduced into this country over a century ago. The saw-flies appear in May or June, and place their eggs just under the surface of the leaf in little cuts which they make for this purpose. The slimy olive-colored slug-like larvæ eat out bits of the upper surface of the leaf, making the leaf turn brown, die and drop from the trees. In some cases trees are completely defoliated. About twenty-five days are necessary for the slug to become full grown, when it sheds its skin for the fifth time, becoming a light orange yellow color, clean and dry, and looking more like a caterpillar in appearance. Transformation to the pupa stage takes place in the soil. There are several generations in a summer, the last does not pupate until the following spring.

Control — The slug is easily killed. Spraying should be done when its work is first noticed. Arsenate of lead, four pounds to fifty gallons of water will be effective. Hellebore dusted on the leaves will destroy the larvæ.

CHAPTER XVI

INSECTS INJURIOUS TO COTTON AND TOBACCO

I. HORNWORMS OR TOBACCO-WORMS. - II. THE MEXICAN COTTON BOLL WEEVIL.

THE HORNWORMS OR TOBACCO-WORMS

These are the best known insect pest of tobacco. There are two species, the northern tobacco-worm and the southern tobacco-worm. Both may attack tomatoes as well as tobacco plants. They are the caterpillars of the sphinx or hawk moth, the large heavy-bodied, slender-winged moths, which appear just before dusk, sucking the nectar from flowers.

Life History — The moths emerge in May and June, having passed the winter as pupæ in the soil, and deposit their eggs on the lower surface of the leaves. In from four to eight days the little caterpillars hatch and begin to burrow the leaves. In about three weeks they are full grown. - The worms are then about three to four inches long and of a dark green color, with diagonal white stripes on the side of each segment. At the tip of the abdomen is a large horn, black in the northern species and red in the southern. It is from this horn that the worm gets its name, and although it is said to be poisonous in reality it is quite harmless. Pupation takes place in the soil, and the adult moth may emerge in about two weeks. There are usually two generations in a season in the South and one in the North. As the worms are carried into the barn with the tobacco at the cutting time, there is danger of their injuring quite an amount of partly dried tobacco.

Control — Hand picking is effective because of their large size and the ease with which the caterpillars are seen. If the worms are very numerous, spraying or dusting with Paris green or arsenate of lead will kill them without harming the tobacco. Careful examination has shown that even after three sprays have been applied, there is not enough of the poison left on the leaves to cause injury to the user of tobacco.

THE MEXICAN COTTON BOLL WEEVIL

No other insect, with the exception of the Rocky Mountain locust, has attracted so much attention in the United States as this pest of the cotton. It is a native of South America and given to us by way of Mexico. It has spread east and north at the rate of sixty miles a year, until it is now found throughout the cotton area of Texas, Louisiana,

Mississippi, Arkansas, Oklahoma and Alabama. In 1904 the loss in Texas was estimated at \$25,000,000 and it was said that the pest had already cost that state \$100,000,000. The injury has not, however, increased in proportion to the spread of the boll weevil, owing to the means which have been used to check it.

Life History—The adult boll weevil is a small brownish weevil about one-fourth of an inch long, with the characteristic snout of the weevil about one-half the length of the body. There are many related weevils which closely resemble this one, but the boll weevil feeds only upon cotton whereas the rest feed upon other plants. The weevil spends the winter in hibernation, emerging soon after the cotton plants have appeared above ground, and continuing to appear until the plants have commenced to square freely. At this time the beetles feed on the



Fig. 35.—The Mexican Cotton Boll Weevil enlarged and natural size.

foliage, particularly on the terminal twigs. As soon as the squares are formed the females commence to lay their eggs in them. Each female produces four or five eggs a day until she has laid about one hundred and forty eggs.

These hatch in three or four days and the grubs feed upon the flower-parts inside of the square, thus preventing the flower from developing, and usually causing the square to fall to the ground. Pupation takes place in the square. From egg to adult requires two or three weeks. The length of the life of the adult depends upon several conditions, but usually does not last over sixty days in summer. The adult weevils feed upon the squares and many more are destroyed in this manner. The female beetle will not place her eggs in a square which has been visited by another female until late in the fall when the scarcity of squares may drive her to use one which has had a previous occupant.

As many as fifteen eggs have been found in one square at this time. The bolls are fairly safe while squares are developing, as the weevils prefer the latter as food and receptacles for eggs. When the squares become unavailable the bolls are attacked. There are four or five generations of this insect in each season. The first frost usually kills the immature stages which are developing at that time, although often in the extreme South they may continue to develop through the year. The beetles wander very wide in search for hibernating places and at this time they will migrate from field to field. Only from two to twenty per cent of the beetles survive the winter in hibernation.

Control — Perhaps the best method of controlling this pest is to plant early varieties of cotton instead of the later varieties. Liberal fertilization will hasten the maturity of the crop and help it to get ahead of the weevil. A most important measure in the control of the boll weevil is the destruction of the plants in the fall as soon as the cotton is picked. This both destroys the weevils and prevents their increase. The stalks should be plowed out and burned as soon as possible. It is well to plow out all but a row here and there upon which the weevils may concentrate and then as soon as the piles are dry enough to burn, cut the remaining rows and burn at once. Crop rotation is good practice as the weevils do not fly far from their hibernating quarters in the spring. When the squares containing the immature larvæ fall to the hot soil they will be killed by the heat. To aid in this the rows should be planted fairly wide apart. Varieties which produce minimum of shade are preferable, as are those that readily shed their squares when injured.

CHAPTER XVII

CONTROL OF FLIES IN RURAL DISTRICTS

- I. THE FLY AS A DISEASE CARRIER. II. DISPOSAL OF MANURE. III. CARE OF GARBAGE.
IV. OUTHOUSES. V. SCREENING.

The Fly as a Disease Carrier — It is not necessary to discuss at length all the diseases such as typhoid, tuberculosis and dysentery which are carried by the filthy house fly, now known as the "typhoid fly." The germs of these diseases are carried upon the mouth parts, feet, hairs of the body, and in the intestine of the fly. It is a notable fact that the typhoid germ will live for a long time in the intestine of a fly and in fly specks.

It is now well known that this insect is a menace to health, yet there are hundreds of homes, boarding houses, hotels, and restaurants throughout the country where this dangerous insect is still tolerated. Thousands of farmers sit down with their wives and children to tables where flies swarm over their food. Laborers, miners, mechanics, and others do not hesitate to partake of fly-specked eatables; to drink milk exposed to contamination in filthy, fly-infested dairies, and in spite of the warnings of the press and state boards of health, look on in apparent equanimity while flies which frequent filth of all kinds, much of it laden with disease germs, light on the nipple of the baby's bottle, or crawl over the face and lips of a delicate child. There are even hospitals, where one would naturally expect every precaution for sanitation, in which the authorities allow the presence of flies, by neglecting the proper screening of doors and windows.

It is claimed that there are in this country annually over 200,000 cases of typhoid, about one-eighth of which are fatal. Intestinal diseases are more numerous during the midsummer or in the early autumn, when house flies are most abundant, showing the connection between these two. As many as 100,000 bacteria, which came from matter voided from the intestine, have been found to be present in one fly.

Disposal of Manure — The fly as a disease carrier is a much more serious problem for consideration in the country districts than in the city. This is quite evident when we consider that our modern cities are provided with sewers and the houses are well screened to prevent the entrance of flies, while in small towns and farm districts little or no attention is given to sanitation. The proper way to combat the fly problem is to destroy the flies before they get wings; or better still, to

prevent them from being at all. Since 95 per cent of all our house flies breed in horse manure, this should be spread upon the fields as soon as possible after being removed from the stable. This precaution also conserves the greatest amount of plant food for fertilizer.

The house fly prefers very fresh horse manure which has begun to ferment sufficiently to provide considerable heat and which is fairly moist. These conditions are found in ordinary manure piles. If this could be drawn out at frequent intervals, say not less than twice a week and spread over the field it would dry out sufficiently to kill any young maggots already in it and would not be a favorable place for the flies to deposit their eggs. Where it is impossible to haul it out as often as this, as in the smaller towns, it should be stored in a tight receptacle until such time as it may be conveniently hauled out.

Care of Garbage—Second in importance comes the care of garbage. If flies are deprived of their favorite breeding place, manure, they will seek others; several species such as the blue-bottle prefer decaying animal matter. At any rate, garbage is invariably sought out for food and who wants the fly to come directly from his repast in the garbage pile to crawl upon the butter set out on the table? Do not let garbage accumulate. If the cook-stove is used during the summer the housewife can burn it in small quantities or if the manure is hauled out to the fields twice a week the garbage can be carried with it. Exposed



Fig. 36.—The Fly often carries summer complaint to children.

Courtesy of the Minnesota Experiment Station

to the sun and air in this way it quickly dries and no harm is done. If neither of these means of disposal are feasible the garbage must be buried. Do not allow it to collect until it has become "fly blown" and then throw a few inches of earth over it. The maggots will hatch and easily make their way through the loose soil. Wrap the garbage from each meal into a tight newspaper bundle and bury these packages every other day or so. A small garbage incinerator bought and run by a farmers' club or some other co-operative association is the best way of providing for garbage disposal in rural districts.

Outhouses—A third source of danger in the country is the outhouse, or privy. Enough has been said concerning the spreading of



Fig. 37.—The House Fly on His Daily Rounds

Courtesy of the Minnesota Experiment Station

typhoid or other intestinal disease germs through flies, to make any one realize the necessity of making this source absolutely fly-proof. Keep the outhouse in good repair. See that the vault is free from cracks and that the earth is filled in close about the walls. Screen the windows and ventilators. Provide the door with a spring that will keep it closed and the seat with a cover that cannot be left opened. A septic tank the construction of which is described in Book V, Chapter VI, is not very expensive and does away with all danger from house sewage. Every farmer should install one for the safety and convenience of his family. In some cases, neighbors have clubbed together and built a common tank that would provide for their needs.

Screening—The fourth precaution to be observed is the proper screening of the house. You may be doing all you can to prevent the breeding of flies, but until all your neighbors do the same you can not live safely or comfortably without screens. Further than this you should refuse to take food supplies from a storekeeper who does not use screens. Such food may be contaminated before it comes into your home.



A Bird Restaurant—Suet tied to bough for nuthatch.

CHAPTER XVIII

BIRDS AS INSECT DESTROYERS

- I. ECONOMIC VALUE OF BIRDS TO THE FARMER—ESTIMATE OF INSECTS CONSUMED BY BIRDS DAILY IN MASSACHUSETTS. II. INSECT-DESTROYING CAPACITY OF BIRDS—AMOUNT OF FOOD REQUIRED BY YOUNG BIRDS; BY ADULT BIRDS. III. GOOD SERVICES OF BIRDS—TREES AND CROPS SAVED FROM DESTRUCTION BY BIRDS—INCREASE OF INSECTS FOLLOWING DESTRUCTION OF BIRDS—BIRDS AS DESTROYERS OF HAIRY CATERPILLARS AND LICE—SERVICES OF BIRDS IN THE ORCHARD—WEED SEEDS CONSUMED BY BIRDS—BIRDS AS RODENT KILLERS—BIRDS AS A SANITARY FORCE. IV. THE ENEMIES OF BIRDS. V. BIRDS AS PESTS. VI. HOW TO ATTRACT BIRDS—WINTER—SPRING—SUMMER—FALL. TABLE NO. 1. BIRDS TO ATTRACT FOR POLICING DIFFERENT VEGETATIONS. TABLE NO. 2. GUIDE FOR PLACING NESTING PLACES.

ECONOMIC VALUE OF BIRDS TO THE FARMER

We have been slow to realize in this country the great economic value of our song birds. Birds have been destroyed recklessly and their nests despoiled by thoughtless huntsmen with very little protection from the average person. Farmers, whose greatest ally the bird is, have been generally the slowest in protecting and encouraging them. When we consider that no less than \$80,000,000 in crop damage is lost by farmers all over the United States through insect pests, we can understand what an asset the insect-eating bird becomes to the farmer whose fields and meadows and orchards harbor them. Certain of our insect-eating birds have been known to eat half their weight in insects in a single day. A few birds of such capacity about the farm are as valuable as the hired man—and they demand no wages.

Estimate of Insects Consumed by Birds Daily in Massachusetts—Mr. C. A. Reed, the Massachusetts ornithologist, computes that a cuckoo consumes daily from 50 to 400 caterpillars or their equivalent, while the chickadee will eat from 200 to 500 insects or up to 4,000 insect or worm

eggs. One hundred insects a day is a conservative estimate of each individual insectivorous bird.

By carefully estimating the birds in several areas of Massachusetts, Mr. Reed found that there were not less than five insect-eating birds per acre, thus the state with its 8,000 square miles had a useful bird population of not less than 25,600,000, which for each day's fare required the enormous total of 2,560,000,000 insects, equal to 21,000 bushels. This estimate is good for five months in the year, from May to September. During the rest of the year the insects, eggs and larvæ destroyed by winter, late fall and early spring birds are equal to half this quantity.

INSECT-DESTROYING CAPACITY OF BIRDS

Amount of Food Required by Young Birds—Young birds come into the world blind, naked and helpless. Yet in a few days or weeks at the very longest, they are almost as large as their parents and are covered with a respectable suit of feathers, quite ready to start out on their life careers. It is no wonder that the parent birds must bend all their energies to supplying the food that accomplishes this marvellous growth. Records kept of the number of visits made by the old birds to their nest during a day show the industry of the devoted parents and the almost unbelievable food capacity of their offspring.

A pair of rose-breasted grosbeaks were watched for a single day in June. Between 6 and 7 A. M., they came to their nest fifty-two times; between 7 and 8, forty-seven times; between 8 and 9, forty-three times. When the watch was given up at 5 o'clock, 426 visits had been paid and the birds were still hard at work with several hours of daylight before them. By the aid of a glass, the food brought could be plainly seen. It consisted entirely of larvæ and caterpillars brought at least two at a time. So in less than a day's work, the pair of birds had disposed of 848 vegetation-destroying pests. This is a conservative estimate for a bird has been known to carry as many as eleven small caterpillars in her beak on one visit to her nest.

A pair of chickadees made six trips to their nest within thirteen minutes. In each case, their bills were filled with a mass of small insects, mainly ants and plant lice.

A mother wren alone paid 110 visits to her nest in four hours and thirty-seven minutes. Each time she bore a grasshopper, a caterpillar or a grub to her family. A pair of long-billed marsh wrens have been seen to carry thirty-one locusts to their nests in an hour.

The common or English sparrow undoubtedly eats fewer insects in proportion to the rest of its food than any of our small native birds.

The Amount of Food Eaten by Adult Birds—It is much harder to determine how much food the full grown bird consumes. Birds in captivity are but poor representatives of their species and lack the vigorous assimilative powers of birds at large. Ornithologists who

have examined the contents of thousands of birds' stomachs, give some surprising statistics. In the stomach of a yellow billed cuckoo 217 fall webworms were found, and in another 250 tent caterpillars. Sixty grasshoppers were found in the stomach of a night hawk. This useful bird has been known to consume 1,000 ants at a single meal. Twenty-eight cutworms were taken from the stomach of a red-winged black bird. A pair of yellow-throats were watched feeding upon plant lice. By the aid of a good glass the number of times each bird picked up an insect could be counted. One apparently consumed 89 in a single minute and as the pair continued to feed at the same rate for over forty minutes, it is estimated that they ate over 7,000 plant lice. These birds were watched for several days during which time they spent at least two or three hours feeding. In a day they probably devoured 10,000 aphides, or 73,500 in a week. Two scarlet tanagers were

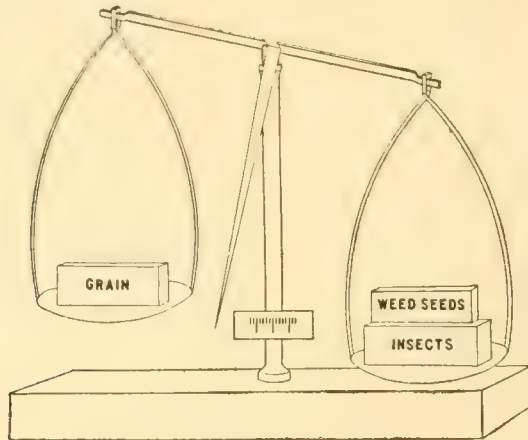

Fig. 1.—Birds Eat More Than Twice as Much Weed Seed and Insects as They Do Grain.

watched eating the small caterpillars of the gypsy moth. They devoured them at the rate of thirty-five a minute. If we assume that they ate at this rate for only one hour a day, in a week they would consume 14,700 caterpillars. Such a number of caterpillars could easily prevent the fruitage of two apple trees.

GOOD SERVICES OF BIRDS

Birds Save Trees and Crops from Destruction—There are plenty of instances recounted in agricultural history to prove that birds have frequently preserved entire crops from destruction. At Salt Lake City a monument has been erected to the sea gulls who saved the crops of the first Mormons from destruction by black crickets. The early settlers in the Mississippi valley suffered severely from the ravages of locusts. There are records stating that fields where locusts had

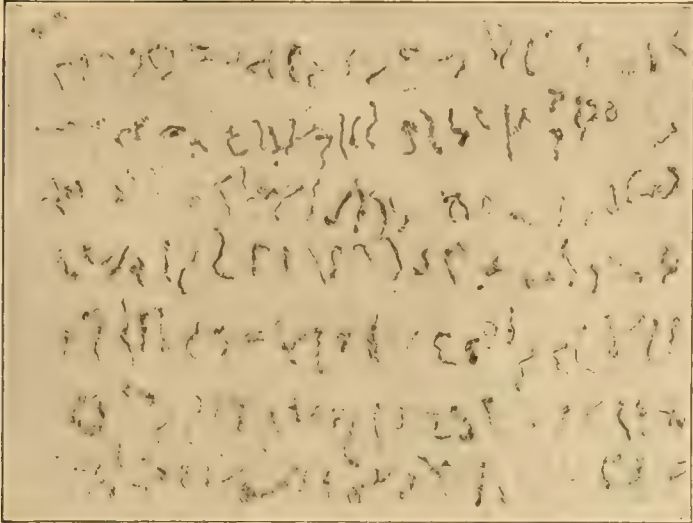

Fig. 2.—Stomach-contents of One Western Robin. Stomach contained 192 small cutworms. Three times this amount of food is required daily.

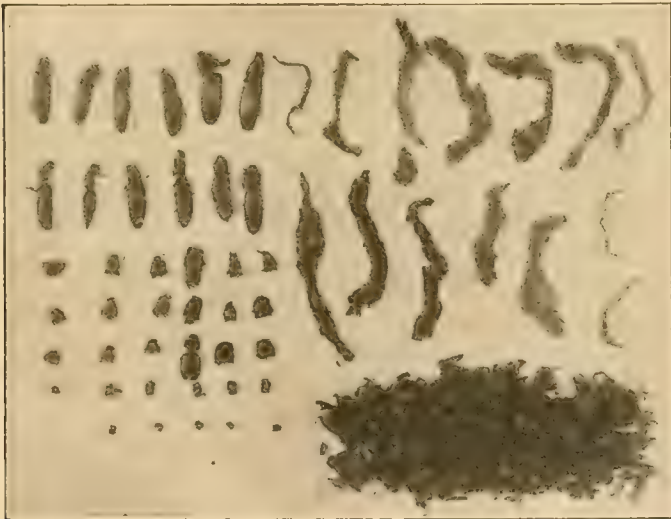

Fig. 3.—Photograph of Stomach-contents of a Western Meadowlark Collected at Big Pine, Inyo County, California. The stomach contained 13 cutworms, 26 click beetles, and 10 small ground beetles.

hatched to the number of 300 to the square foot were completely cleared of the pests by blackbirds in a few weeks' time and the crops saved. A severe outbreak of the tent caterpillar occurred in New York a few years ago. Thousands of acres of valuable woodland were devastated and much damage done to the sugar maples of that region. After the caterpillars came the birds in great flocks, warblers, orioles, sparrows, robins, cedar birds, and by the end of two years the plague was reduced so that its ravages were no longer noticeable. There are many accounts of minor insect uprisings checked by birds, but still due credit has scarcely been given these untiring vigilants for their services.

The Increase of Injurious Insects Following the Destruction of Birds—Far from giving them credit, they have long been regarded as robbers of cornfields and orchards. An old tale is recounted of Frederick the Great, king of Prussia. Observing sparrows feasting upon his favorite cherries, he indignantly ordered the destruction of the birds. His commands were carried out so vigorously that soon there were no sparrows left in Prussia, and shortly after no cherries. The trees were stripped bare by caterpillars which flourished undisturbed in the quiet orchards. Frederick the Great seeing the error of his ways, was forced to import sparrows to regain his cherries.

The early settlers of America set to work vigorously destroying the birds which attacked their crops. Crows and blackbirds came in for a great share of ill will and in some of the northern states were completely exterminated. Coincident with this was the entire loss of the grass and grain crops in the same districts.

Birds as Destroyers of Hairy Caterpillars and Lice—There has long been a theory among naturalists and people generally that birds have no appetite for hairy caterpillars nor for those that conceal themselves in webs like the tent caterpillar. However, Dr. Forbush, Ornithologist of the Massachusetts State Board of Agriculture, has collected a mass of interesting data to the contrary. As the larvæ of those exceedingly troublesome pests, the gypsy moth and the brown tail moth, are hairy caterpillars, Dr. Forbush's reports on reliable authority are well worth considering. Birds have been observed feeding regularly and with gusto upon gypsy-moth caterpillars, brown-tail larvæ and tent caterpillars. In the latter case, they nip the web open with their beaks and extract the occupants. Plant lice also are popularly supposed to be distasteful to the feathered epicures, but Dr. Forbush quotes many instances to the contrary. Following is a partial list of common birds frequently observed feeding upon hairy caterpillars and plant lice:

American Cuckoo
Northern Flicker
Kingbird

Bobolink
Rose-breasted Grosbeak
Scarlet Tanager

Crested Flycatcher
 Wood Pewee
 Bluejay
 Crow
 Redwinged Blackbird
 Baltimore Oriole

Catbird
 Brown Thrasher
 Chickadee
 Thrush
 American Robin
 Bluebird

The Service of Birds in the Orchard—The bird enthusiast must not claim too much prowess for his proteges in guarding the farmer's fruit trees. He does not believe that spraying or other preventatives invented by modern horticulture should be discarded in favor of inviting the warblers into the orchard and letting them do the work. He admits that birds do very little against the San José scale, the codling moth and the railroad worm; he also admits regretfully that the birds will take their toll of the ripening fruit. However, he insists that a birdless orchard could never be a completely fruitful one. Birds if protected and encouraged are quite capable of taking care of the canker worm and the tent caterpillar. Plant lice, the pear tree scylla among them, are destroyed by thousands every year in orchards whose owners never dream of the aphides' existence; nor of the debt owed to the sharp-eyed feathered visitors for the destruction of these harmful pests.

Weed Seed Consumed by Birds—Our government has noted that the English sparrow is beginning an onslaught on the notorious dandelion which packs whole fields in the East and Middle West. Sparrows ate 93 per cent of the seeds of all the dandelions thickly sprinkled in a square yard of lawn at Washington, D. C. The goldfinches and native sparrows are even more thorough on annual weeds. In a Maryland cornfield, matted with smartweed three feet high, the soil was blackened with its seeds, but these were nearly all cracked open during the winter season by song, chipping, and field sparrows. On an area of eighteen square inches 1,130 shells of eaten seeds were found, and only two whole seeds. During the colder part of the winter, juncos, tree, white-throated, and fox sparrows did the work, often scratching up much of the seed buried under snow and leaves. Game birds and mourning doves eat the most weed seeds per head, hence the urgency to encourage the multiplication of these species. A duck shot in Louisiana had its stomach filled with 72,000 seeds.

On account of migration the character of weed-seed eating birds is changed twice a year. Since sparrows outnumber all other birds, let us keep the shifts in mind:

Summer Sparrow Population.
 Dickcissels
 Song sparrows

Winter Sparrow Population
 Snowflakes
 Juncos

Field sparrows	Longspurs
Chipping sparrows	Fox sparrows
Vesper sparrows	Tree sparrows (winter chippy)
Lark sparrows	White-throated sparrows
Harris sparrows	White-crowned sparrows
Grasshopper sparrows	English sparrows

The clean-up of weed seeds by all these birds runs as high as 80 per cent in the weediest of fields. If the birds don't clean up their share, it is recommended that Hungarian millet and hemp be grown along fence rows until enough birds can be attracted to consume the 80 per cent. Some undigested weed seed may be scattered with excrement, but the birds' value as weed destroyers and tree planters far exceeds the incidental spreading of weeds.



Fig. 4.—Sea Gull Coast Patrol at La Jolla, Cal.

Birds as Rodent Killers — A great group of helpers on the farm are the rodent-killers or birds of prey — hawks and owls. As these include chicken hawks, every farmer lad claims to know them. But what is a chicken hawk? It is ordinarily listed as a “bad” hawk. In 1885 Pennsylvania farmers placed a bounty of fifty cents a head on chicken hawks and owls, but little reckoned that they would pay in the very first year and a half \$90,000 cash for bounties. Meantime, through unchecked multiplication of field mice and rats, these rodents cost them over \$3,850,000 in standing grain. So sharp and bitter was the lesson on every farm that the farmers petitioned the next legislature to cancel the law, and more than that, to bring in hawks and owls from outside the state.

Cooper's hawks, sharp-shinned hawks, and the American goshawks are bad; the rest are beneficial. Food analysis of stomachs show that snowy and great-horned owls are pests; others are chiefly beneficial. Best of them all, perhaps, is the barn owl, or monkey-faced owl, for it very seldom poaches on little chickens, preferring rats and mice. The screech owl does sometimes steal chickens, but in spite of that it does more good than harm. The barn owl is a better mouser than the cat and requires less care. So we make a mistake when we keep the cat and drive out the owls. The average cat catches 50 mice a year, and these may cause \$125 of damage to crops and property; but the cat also destroys about fifty insect-eating birds and nestlings whose value as crop savers would have been \$250. (Birds are accredited with an



Fig. 5.—Gulls Patrolling Great Lakes for Dead Fish.

annual value of \$5 per head in crops saved.) This means a loss of \$125 from the insects which the cat's victims were not allowed to destroy. A good business man would rather buy mouse traps and spend a few moments baiting them, than keep cats which eat birds as well as mice.

A certain barn owl nesting cavity had a half bushel of pocket gopher remains. Think what that means when a single gopher has been known to girdle in a short time seven young apricot trees worth \$100. Hawks work by day and owls by night, two shifts combining to fight and destroy the rodents, throughout the twenty-four hours.

Birds as a Sanitary Force—Just as law protects turkeys for street cleaning in squalid semi-tropical towns, so northward, sea gulls are

protected for a similar beneficent work along the shore lines of our sea coasts and inland lakes. In fact, it is a common custom for farmers to get such of their lands as have nesting colonies of these birds or of the Franklin gull, made into federal or state bird preserves. At Beverly, Mass., millions of dead herring were suddenly swept up by the waves to rot along the shore. The air became polluted; maggots swarmed turning into bluebottle flies to carry pus germs far and wide; people fell ill. Then great flocks of white gulls swept in and devoured the fish that menaced the health of this summer resort. Inland as well, sea gulls scavenge the Great Lakes and search all small bodies of water when the ice breaks up and dead fish as well as other fish float to the surface. It is so easy to forget the similar work done by birds on the farm. The phoebe flycatcher and eave swallow eat up the house and stable flies, which are carriers of filth and disease germs. Likewise, the swallow and the martin eat up the bots and stable flies which pester the stock.

THE ENEMIES OF BIRDS

Man for love of sport, woman for love of finery, and thoughtless boys make mankind rank as the worst enemy of bird life. Their inconsiderate acts added to the natural preying of the stronger upon the weak, threaten some species of insectivorous birds with extinction. Cats take from the feathered ranks a large yearly toll which could easily be prevented. Homeless cats should not be tolerated any more than homeless dogs. Pet cats could be belled to warn wild birds of their approach. Weasels, foxes, minks, and skunks, all of which eat ground-nesting, game and insectivorous birds, are so destructive that they ought to be tolerated only on fur farms. Red and grey squirrels, snakes, rats, and mice climb to the highest nests and bird boxes; they gnaw the boxes, and kill and drive out both old and young. They also raise havoc with ground-nesting birds. Red squirrels are the worst offenders and should be shot.

Birds of prey destroy more wild birds than they do poultry. Crows, bluejays, and magpies also eat young birds or eggs, destroy nests, and finally drive away all other birds. Where these are a serious pest, kill them. Since our knowledge as to how much harm such birds really do is still scanty, it might be wiser to vest discretionary powers for destroying these birds of prey with experts or game commissions to destroy these enemies which vary much in different states.

BIRDS AS PESTS

In our enthusiasm we may seem to forget the damage that insect-eating birds do to the farmers' crops. His indignation would be deserved if such were the case. His garden, grain, fruit, beans, peas are all pilfered unde-

nably; but even then the birds are not taking full pay for the services rendered. Instead of driving birds off for their depredations, we would suggest encouraging their presence and trying to limit the harm they do by various precautions. If grosbeak, bluejays and red-headed woodpeckers jab holes into the ripening apples during prolonged periods of drouth, try placing drinking cups in a shelter safe from cats to solve the trouble. Nursery men report stopping damage to small fruits and cherries by planting mulberry and wild cherry trees around the fruit plots. To stop crows and blackbirds from pulling young seed corn, try tarring the seed. Soak seed 12 hours in water, in tar oil a few minutes and then coat with fine wood dust or ashes. It is more effective than a scare crow for it keeps the blackbirds from the corn without scaring them away from the white grubs.

Birds are blamed for the distribution of many pests and diseases from San José scale carried on the sparrows' legs from tree to tree to the spread of hog cholera and foot and mouth disease. Information on this subject is still too insufficient to form conclusive evidence, but the English sparrow seems to be the chief culprit in most instances. Beyond his capacity for eating weed seed nothing can be said in favor of the English sparrow. He is a noisy dirty pest, pecking at everything and driving the insect-eating birds out of every community where he gets a good foothold. He should be destroyed whenever he makes his appearance. The different species of hawks should also be known and distinguished. Rural schools should teach how to tell the good from the bad, and then the sport-loving instinct of the boy could be utilized on the right side.

HOW TO ATTRACT THE BIRDS

Whatever the farmers' bird grievances, wholesale destruction of birds has already been explained as suicidal to farm interests. Dr. Henshaw says that 1,200 kinds of birds inhabit the United States. Most of them have been proved useful. Farmers should know fifty of the commoner species, protect them and coax them into their service.

Meager suggestions follow to assist the pioneer in the new science of bird attraction.

The canon of its law is: Provide food, shelter, drinking water, dry sand and water baths, and nesting places.

Winter — Housewives should get the habit of crumbling the tablecloths into bird feeding shelves (for nuthatches, native sparrows, bluejays) and hanging up all pork rinds, fat and suet trimmings on trees (for all birds but sparrows), for the winter feeding of birds is probably the greatest factor in maintaining our bird population.

Cocoanuts cut in half attract chickadees. Raw peanuts may also be used. If shelled and soaked in warm water until swollen, more birds eat them; or if ground in the meat grinder, they cannot be carried away by the large jays before the smaller birds get a chance at them (for chickadees, nuthatches and jays).

To make a food-ball, heat suet in the oven, mix with ground, raw peanuts or other nuts, and bread crumbs; knead into ball and hang up in a string mash bag (for all birds). Wild birds will climb all over this food-ball while English sparrows will be afraid to perch on any infernal contraption dangling near our houses. Automatic chicken feeders may be hung up filled with ground bread, peanuts or canary bird seed.

In November, gradually begin winter feeding so that a sudden change to winter weather and snow will not leave the birds unprovided for or ignorant of a dependable food supply. In winter, cornstalk shelters can be made and food thrown under for field birds.

Spring — Consult your experiment station horticulturist as to the best and cheapest landscaping you can do on your home farm in the way of providing bird foods, remembering that there are two or three hundred species of shrubs and trees which will provide food and shelter, such as the following types:

Berry Plants	Number of Species of Birds	Time when Fruit is Ripe or Used as Food
Elderberries.....	Eaten by 67 species.	August, September.
Blackberries.....	Eaten by 60 species.	July, August.
Raspberries.....	Eaten by 48 species.	July.
Mulberries.....	Eaten by 47 species.	July.
Dogwood berries.....	Eaten by 44 species.	July.
Non-poisonous Sumachs.....	Eaten by 39 species.	Eaten following spring.
Wild cherry.....	Eaten by 37 species.	Time of cultivated cherry.
Blueberry.....		



Fig. 6.—The Sand Bath.

Make a planting plant to provide food and shelter all the year, e. g., for the Lake State region, plant Juneberry, mulberry, red cedar in clumps for shelter and food, or sumach, raspberry, elders and dogwood. Let the trees be in the center and the smallest bushes outside or vice versa.

Place drinking pools in protected sites that your summer birds may not forsake your fields during drought, or peck your fruit for sap. Most birds also seem to need open water to drink from in winter.

Place shallow bird baths in shady spots and nail upon a post in the sun near at hand a pan of fine sand or gravelly sand, so the birds can dust out their body lice or replenish the grinding stones in their crops or digesting grain or hard insects.

Hang out nesting material in spring, in short lengths—not long horse hairs or strings—for wild birds often hang themselves in weaving long ones into their nests. Bird houses can be made out of tomato cans, or by fastening up flower pots, open end to the wall and with the bottom hole chipped out as large as a quarter, for wrens; out of old shingles or clay pots for bluebirds; out of bark, or slabs with bark on, for chickadees and nuthatches; out of old log posts or telephone pole butts for woodpeckers and owls. Soap boxes without covers will do for robins; a horizontal piece of board to meet the sloping eaves for phoebes and swallows; a hollow log or sleeve of wood perched on the ridgepole next the chimney for chimney swifts; a keg with several false floors in it, bored with many wood-auger holes, for purple martins. Place the latter on the windmill tower, halfway up or less, as the birds wish a wide sweep for flying to and about their homes. Martins will not take well to a single-roomed house, since they are colonial social birds. For those who can spend a little money, the catalogs of the various bird house manufacturing companies offer a wider choice.

By May complete all provision for nesting sites, as May and June are the chief breeding months.

Summer—Drinking pools and bird baths save the lives of panting birds in the July and August heat. Along washouts, unused garden edges, barren fence lines, or on plowed up old weed beds, plant

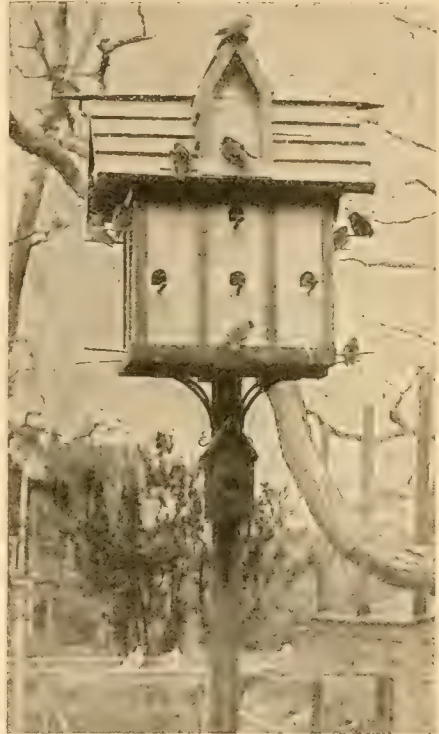

Fig. 7.—Martin House. Sheltering 17 Pairs with Young.

Hungarian millet, Russian sunflowers, or hemp, so that migratory sparrows in fall will find enough food and so stop longer for your weed seed.

Fall—Place nesting boxes in October, November and December, thus giving over-wintering birds the opportunity to get accustomed to them before the need of spring quarters.

For further directions, see the following tables:

TABLE No. 1
BIRDS TO ATTRACT FOR POLICING DIFFERENT VEGETATIONS,
IN FIELD AND PASTURE

Bird	Pest
Bob-white.....	Weed seed—chinch bugs—currant aphides.
Cow-bird.....	Cattle ticks—ox warble—fly weevils.
Crows, grackle, blackbird.....	White grub—wireworm—corn weevils.
Martins, bank swallows.....	Common injurious insects.
Meadow lark.....	Locusts—beetles—common insects.
Sand piper, plovers, gulls.....	Grasshoppers—weed seed—beetles—ants.
Sparrows (field, etc.).....	Weed seed—grasshoppers—cutworm.

TO EXTERMINATE RODENTS

Good hawks, all herons.....	Meadow mice—rats—ground squirrels—locusts—beetles.
Good owls, shrikes.....	Mice—rats—English sparrows.

FOR DOORYARD, SHRUBBERY AND LAWN

Purple martin.....	Wasps—bugs—beetles, etc.
Quail.....	Potato bug—weed seed.
Wren.....	Locusts—beetles—caterpillars—plant lice, etc.
Brown thrasher, cat bird.....	Beetles, (horn, snout, boring, etc.)—caterpillars—ants—currant worms.
Yellow warblers.....	Black olive scales—cucumber beetles—flies—ants—bugs, etc.
Gold finches.....	Dandelion and thistle seed.
Robins.....	Cutworms—earthworms—ground beetles.
Woodpecker—flicker yellow hammer.....	Ants—sucking bugs—ground beetles.

FOR ORCHARD

Winter Species:	
Nuthatch.....	} Caterpillars (apple worm—span worm) plant lice eggs—scales—bark beetles—flies.
Chickadee.....	
Bush tit.....	
Woodpecker.....	Apple worms—timber borers—eggs of caterpillars—grasshoppers.
Spring Species:	
Kinglet ruby, golden crowned.....	} Spanworms—cutworms—curculios—ants—moths—bibio grassworms—wireworms.
Robins.....	
Bluebird.....	
Nuthatch.....	

Summer Species:

Yellow and black billed cuckoos.....	} Weed seeds.
Grosbeaks.....	
Dove (mourning).....	Plum curculio.
Flycatchers.....	} Caterpillars—plum curculio—house flies—ants—scale.
Vireos.....	
Humming birds.....	
Oriole.....	
	Caterpillar (hairy webworm) beetles—ants—grasshoppers—scale.

FOR WOODLOT AND FOREST

Winter Species:	
Brown creeper.....	} May beetles—nut weevils—wood borers—hairy caterpillars eggs.
Downy and hairy woodpecker.....	
Crows, blue jay.....	
Woodpeckers.....	Round and flat-headed borers.
Spring Species:	
Fly catchers—thrushes, whippoorwill, game birds, ruffled grouse.....	Weed seed—May beetles—and other pests.
Kinglets.....	Plant lice—tree hoppers and others.
Swifts, chimney.....	Shot hole and bark borer, swarms in flight.
Summer Species:	
Bunting.....	} Tree and leaf hoppers—spittle insects—flies—aphides—scales—beetles—moths—ants—spanworms.
Warblers, myrtle.....	
Ovenbirds.....	

FOR TRUCK CROPS AND GARDEN

Bird	Pest
Grackles, blackbirds.....	Army worm—ground beetles—curculios.
Grosbeaks, rose breasted.....	Potato bugs—leaf-eating beetles.
Prairie chickens.....	Grasshoppers—weed seed.
Sparrows (tree, etc.).....	Cabbage worms.

FOR SCAVENGING

Winter Species:

Bald eagles, crows, magpies, ravens, vultures, turkey buzzards.....	} Inland scavengers of carrion, rats.
Eagles, sea gulls.....	

Shore line scavengers of carrion and flesh flies.

Spring and Summer Species:

Fly catchers—phoebe, peewee..	Disease bearing flies and mosquitoes.
Purple Martin.....	} Flies—ox warble—bot—horse flies.
Barn swallow.....	
Plovers, Upland, killdeer.....	Cattle ticks—horse flies—salt marsh-mosquitoes.
Spotted sand piper, shore birds.....	Mosquitoes—sand flies—black flies.

TABLE No. 2
GUIDE FOR PLACING NESTING PLACES

Bird	Kind of Nest	Hgt. from Ground	Diameter Entrance	Location
Blue bird.....	Box 12x6x6 in. Log 11-15 in.	10-12 ft.	1.5-2.4 in.	Orchard, nr. dwellings
Chickadee.....	Box 7x5x5 in. Log 7-14 in.	8 ft.	1 -1.8 in.	Quiet groves, orchards.
Creepers.....	Log 7-14 in.	30 ft.	1.3-3.2 in.	Groves—orchards.
Chimney swift.....	Box 10-20x4x4 in. or log on ridge pole.			Barn—houses.
Duck, American, Merganser.....	Shelf 12x16 in.	12 ft.		Groves, near water.
Duck, golden eye.....	Shelf 12x16 in.	30 ft.		Groves, near water.
Duck, wood.....	Shelf 12x16 in.	40 ft.		Groves, near water, swamps.
Flicker.....	Box 10x6x15 in.	15-20 ft.	2.2-5 in.	Orchard—poles.
Flycatcher.....	Gourds	9-12 ft.	1.8-2.2 in.	Garden.
Phoebe.....	Shelf 2x3 in.	12-15 ft.	2.3-4.3 in.	Bridges, houses, barn.
Grackle.....		15-20 ft.	1.8 in.	
Martin, purple.....	House (each room) 12x6x10 in.	20-25 ft.	1.8-3.2 in.	Barns, poles near water.
Nuthatch, red breasted.	Box 10x4x4 in. Log 7-14 in.	20 ft.	1 -1.8 in.	Shady groves.
Nuthatch, white breasted	Box 12x6x6 in. Log 6-12 in.	15 ft.	1.5-1.8 in.	Groves, near water. orchard.
Owl, Acadian.....	Log 12-16 in.	15-60 ft.	2.4-3.3 in.	Near dwellings, evergreens.
Owl, barn.....	Log 12-16 in.	12-15 ft.	3 -3 in.	Near dwellings, evergreens.
Owl, screech.....	Log 12-16 in.	20 ft.	3 -4 in.	Barns, orchards. Near dwellings.
Robin.....	Shelf.			Field, garden, orchard.
Sparrows hawk.....	Log 12-16 in.	20 ft.	2.4-3 in.	Field, garden, orchard.
Starling (a pest).....	Box.			Barns, garden, houses
Swallow, barn.....	Shelf.			Arbors, barns, poles.
Swallow, tree.....	Box 12x6x6 in. Log 7-14 in.	12-15 ft.	1.3-1.8 in.	Arbors, barns, poles.
Warbler.....	Log 7-14 in.		1.3-1.8 in.	Arbors, barns, poles.
Woodpecker, downy.....	Log 11-12 in.	10 ft.	1.8 in.	Groves, orchards.
Woodpecker, hairy.....	Log 11-15 in.	20 ft.	2.4 in.	Swamps—woods.
Woodpecker, pileated.....	Log 12-16 in.	20 ft.	3.3 in.	Shady woods.
Woodpecker, red breasted.....	Log 14-18 in.	20 ft.	2 -2.4 in.	Fences and gourds.
Woodpecker, red headed.	Log 14-15 in.	15 ft.	2.4 in.	Gardens and woods.
Woodpecker, three toed.		20 ft.	2.4 in.	Evergreens and woods.
Yellow breasted sap sucker.....	Log 14-15 in.	15-20 ft.	2.4 in.	Shady wood.
Wren, Carolina.....	Log 2-14 in.	6 ft.	1.8-3 in.	Barns, fences.
Wren, house.....	Box 7x5x5 in.	8-12 ft.	1 -1.8 in.	Near dwellings.

TERMS—Box—Nesting box; inside dimensions are given throughout table.

Log—Hollowed logs for birds which inhabit cavities in trees. Figures give depth to which the excavation should be made.

Shelf—Board shelf on which bird may build nest, or a soap box without a cover

PART II— PLANT DISEASES

CHAPTER I

DISEASES OF CEREAL CROPS

- I. INTRODUCTION—ECONOMIC IMPORTANCE OF PLANT DISEASE—WHEAT—RUST—SMUT—TREATMENT FOR BUNT—TREATMENT FOR LOOSE SMUTS—SEEDLING DISEASES—SCAB. II. OATS—RUST—SMUT—BLADE BLIGHT OR BLAST—SEEDLING DISEASES. III. BARLEY—RUST—SMUT—STRIPE DISEASES. IV. RYE—RUST—SMUT—ERGOT. V. CORN SMUT. VI. FLAX—RUST—WILT.

INTRODUCTION: ECONOMIC IMPORTANCE OF PLANT DISEASES

It is a well established fact that plant diseases cause a loss of millions of dollars to the farmers of the country annually. This entire loss is not always noticed on account of the fact that diseases are not always recognized as the immediate cause. However, a few figures on the losses due to specific diseases may serve to show the importance of this phase of agriculture more clearly. A conservative estimate of the loss to the wheat crop in 1904 in the three states, Minnesota, North Dakota, and South Dakota, due to wheat rust would be \$20,000,000.00. During the summer of 1914, the loss probably was nearly if not quite as great. Such losses due to wheat rust alone are not at all uncommon in the spring wheat states in moderately bad rust years. It would be safe to say that the annual loss due to smuts of grain crops in the three states previously mentioned and Wisconsin would be at least \$15,000,000.00, and if more accurate figures were available it is very probable the figures would be even higher than this.

It has been stated by competent authorities that the annual loss in the United States due to the late blight of potatoes is at least \$50,000,000.00. If accurate figures were available the total loss from all combined plant diseases of farm crops in the Northwest alone would amount to almost unbelievable figures. A very large percentage of this loss can be prevented by intelligent methods of controlling these various diseases.

The Nature of Plant Diseases—Diseases of plants are caused mainly by fungi and bacteria, or by unfavorable soil or weather conditions. Those which will be considered here are practically all caused by parasites, that is, either by fungi or bacteria. Fungi and bacteria are very minute plants, which often cannot be seen without the aid of the microscope. They cannot make their own food material, being

without the leaf green which enables green plants to manufacture their food. Since they cannot make their own food they must get it either from dead plant or animal remains or from living plants or animals. Those which cause diseases of plants get on or into the plants, absorb their nourishment from them, and in this way lessen the vitality of the plants or actually kill them.

There are different kinds of fungi and bacteria which may, in general, be referred to as germs. They may live on different kinds of plants, and also on different parts of the same plant, for instance: The germ which causes the soft rot of vegetables is different in kind from the germ which causes smut of wheat. In the same way the germ which causes the bunt or stinking smut of wheat is different from the one which causes the covered smut of barley. It therefore becomes necessary to know what kind of germ is causing a particular disease, and further to know the habits of this particular germ. This is all the more true, since the different kinds of germs may have very different habits, and therefore must be controlled by different methods. It is absolutely necessary therefore for a farmer, before he attempts to control a disease, to know what germ causes the disease and how it acts in order that he may apply his preventive measures at the proper time and in the proper place.

WHEAT

Rust—The rust of grain crops has long been known as one of the most destructive pests of cereal crops. There are two kinds of rust on wheat: the stem rust is found mostly on the sheaths and stems, while the leaf rust is found more on the leaves. The color of the leaf rust is lighter than that of the stem rust. Of the two, the stem rust does by far the greater damage in the spring-wheat growing states. It is, therefore, the one which is considered here.

Unfortunately, nothing much can be said about the control of wheat rust. It is a disease caused by a fungus which lives not only on wheat and other cereals but also on about fifty different native grasses. In completing its life cycle it also gets on the barberry, a plant which is used rather extensively as an ornamental shrub, but which does not grow wild to any extent, in the wheat growing states.

Briefly, the life story of the wheat rust fungus is as follows: The black rust which occurs on the grain in the fall lives over the winter, and in the spring the spores (roughly speaking, the seeds of the fungus) germinate and produce other little spores which are blown to the barberry plant, germinate there, send delicate threads into the plant and eventually cause the so-called cluster cups on the leaves. The spores from these cluster cups are blown to wheat, germinate on the wheat and produce the red rust stage. Later in the season, especially when the wheat is maturing, the black rust, which is merely a later stage of

the red rust, appears. It should be remembered that the red rust and the black rust are merely different stages of the same disease. Sometimes the term black rust is used to apply to stem rust, and the term red rust is used to apply to leaf rust. However, in both cases, during the earlier part of the summer, the rust is red and later in the season becomes black.

The rust from one cereal does not necessarily transfer to another, for instance: the rust from wheat does not transfer readily to oats, nor does the rust from oats transfer readily to wheat. The rust from barley transfers quite readily to wheat and sometimes to rye, but there are a great many variations in the possibilities of the transfer from one cereal to another. The same thing is true of the possibility of the transfer of rust from the wild grasses to the different cereals; it will transfer from some of the grasses to some of the cereals and from others of the grasses to other cereals, for instance: the rust from orchard grass transfers quite readily to oats, but not to any of the other cereals. The rust from quack grass transfers quite readily to barley and rye but not very readily to wheat and practically not at all to oats.

Not enough is known at the present time concerning the possibility of the transfers of rust from grasses to the cereals to make possible the formulation of definite statements concerning all of them. In general, however, it may be said that grasses such as quack, wild barley and other grasses which are of no particular value should be kept away from grain fields as much as possible.

The possible methods of control of wheat rust, which have been suggested up to the present time are as follows:

1. The elimination of barberry.
2. The elimination of useless wild grasses, in so far as is practicable.
3. The selection of seed from fields which have shown no rust.
4. The withholding of excessive nitrogenous fertilizers from grain fields.
5. The growing of resistant varieties.

Of these, the last is probably the only one which at the present time can be said to be practicable.

It is a well known fact that a great many of the macaroni or durum wheats are highly resistant to rust. It has therefore been suggested by many people that these wheats might be substituted for the hard spring wheats in those regions where rust is usually serious. However, the fact that the milling and baking qualities of the hard spring wheats are more desired, would make this of doubtful value in all cases. Probably the best method of attack is to cross the hard spring wheats with durum wheats in the hope of getting a hybrid which will combine the milling and baking qualities of the spring wheats with the rust resistant qualities of the durum wheats. Work of this kind has been under way

for some time and it is possible, and even probable, that a hybrid will be secured which will combine these qualities. Until then, it is very doubtful whether or not much can be done to control the rust of wheat and of the cereals in general.

Smut—There are two smuts of wheat common in the wheat growing sections, the so-called loose smut or naked smut, sometimes also called



Fig. 1.—Smuts of Wheat—A, Normal head and kernels; B, Stinking Smut, note the smut balls at (a); C, Loose Smut.

Courtesy of the Minnesota Experiment Station.

black-heads, and the bunt or stinking smut. The farmer should distinguish carefully between these two smuts. The loose smut shows up more clearly than the stinking smut or bunt. The spore mass in the loose smut is dry and powdery and easily blown away by the wind, leaving nothing but the bare stalk where the head should be. In the case of the bunt, however, the smutted kernels are under the chaff and

are not always so easy to detect. The difference is shown clearly in Fig. 1.

The method of spread of the two smuts is entirely different. In the case of the loose smut, the smut powder is blown around about flowering time of the wheat; it gets between the chaff and the spores germinate there and the smut plant gets inside the very young kernel. It lives there during the winter, and in the spring starts growing at the same time the seed germinates; and the smut threads inside of the seed keep pace with the growing point of the stem and at heading out time the very young kernel is again reduced to a smut mass. The essential point is to remember that the smut during the winter is inside of the kernel. In the case of bunt the conditions are entirely different, the smut powder is broken up in handling the grain, mostly about threshing time, gets onto the outside of the kernel and lives over until the next spring. Then when the seed germinates the smut spores also germinate and the smut threads get inside of the very young seedling just as it comes from the seed. The treatment for the two is therefore different.

Treatment for Bunt—The easiest and most effective method, and the one which is probably most used is the formaldehyde treatment. Formaldehyde is also called formalin; this, however, is merely a trade name. In using this treatment one should be sure first of all to have the formaldehyde of standard strength. It should be 40%, which means 40% of the gas is in solution in water. If there is any question as to the strength, a sample should be sent to the nearest experiment station chemist for analysis. Before treating, the seed grain should be carefully cleaned and then put into water so that the smut balls will come to the surface. They should then be skimmed off. The solution of formaldehyde is made up, using one pint of formaldehyde to forty or forty-five gallons of water. This should be thoroughly stirred and the grain may then be treated in either of two ways.

It may be put into sacks or baskets lined with wire screening and dipped into the solution of formaldehyde, or spread out on a clean floor and sprinkled with the solution of formaldehyde. If the dipping method is used the grain should be dipped into the solution, lifted out and drained, and then dipped in again two or three times. Every kernel should become wet. It is better to use rather small quantities of the grain at a time, in order that the wetting of every kernel may be brought about more easily. Then put the grain into a pile and cover it with clean sacking or clean canvas for twelve to twenty-four hours, and either sow immediately, being sure to set the seeder or drill for the swollen kernels, or spread it out to dry and keep until seeding time. It is very important that the seed grain after it has been treated should not again come in contact with anything which has contained smutty

grain. The floor on which the grain is piled, the wagon boxes which may be used, the seeder or drill, and even the sacks should be very thoroughly cleaned if they have contained smutty grain before. This may be done by boiling the sacks and by scrubbing the floor and wagon boxes and seeder with a solution of formaldehyde made up at the rate of one pint of formaldehyde to ten gallons of water.

The sprinkling system does not differ materially from the dipping treatment except that the grain is spread out in a thin layer on the floor previously cleaned, and as one man rakes or shovels the grain, another one sprinkles the formaldehyde solution onto it. The idea here, again, is to get every kernel wet. After the process is complete the grain is covered in the same manner as in the dipping treatment and is handled in the same way subsequently.

Grain may be treated at any time and may be kept indefinitely without becoming again contaminated, unless it is brought into contact with something which has contained smutty grain. The greatest precaution should therefore be taken to keep it clean. It should not be allowed to freeze while wet. The cost of the treatment is extremely small. It does not exceed two or three cents per acre, and wherever bunt or stinking smut is severe it ought by all means be used, as it is the cheapest insurance which can possibly be obtained against the losses due to bunt.

Treatment for Loose Smuts—The treatment for loose smuts is not so easy as that for the bunt. The reason for this is apparent when it is recalled that the smut is inside of the kernel. The treatment being rather difficult of application, and being such that only small quantities can be treated at a time, should be made only with the idea of establishing a seed plat. The seed plat should be a good, well cultivated piece of land which is separated as far as possible from any other field growing the kind of grain which is to be sown on the plat. The grain should first be very well cleaned and then should be soaked in water at ordinary room temperature for from five to seven hours. Then it should be placed in small coarse-mesh sacks or wire baskets, in amounts of not over a half-peck each, and drained for a short time. Then two tubs or vats of water should be provided. In one tub (No. 1), the water should be heated to about 45° or 50° Centigrade; in the second tub the temperature of the water should be 54° C. (129.2° F.). It should not be allowed to go below 51° C. (123.8° F.) or above 55° C. (131° F.). The grain should first be put into tub No. 1 to bring it up to approximately the temperature of the water in tub No. 2 in order not to lower the temperature in that tub. It should then be put into tub No. 2 and be kept for ten minutes at a temperature of 54° C. (129.2° F.). If the temperature should rise above 54° C. (129.2° F.) or fall below 52° C. (125.6° F.) the time should be either increased or decreased accordingly.

It is of the utmost importance that good thermometers be used; the ordinary thermometer is not accurate enough for this purpose. A standard thermometer is the only one which should be used. A thermometer may be procured and submitted to the Bureau of Standards, Washington, D. C., for tests. A charge of about fifty cents will be made for standardizing the instrument. The success of the treatment depends on the maintenance of the temperature within the limits prescribed above. Since only small amounts can be treated at a time it is recommended that enough be treated in this manner to sow in the seed plat. If this seed plat is isolated from other grain fields of the same kind it should not become smutted during flowering time. The crop may then be used as seed for the next year and the amount gradually increased until enough is grown to sow the entire acreage.

Recently some experiments have been made in an attempt to control the loose smuts by means of long soaking in formaldehyde solution and other chemicals, but these have not yet progressed sufficiently to make it possible to recommend them for general use.

Seedling Diseases—(See Fig. 2). During the past few years the idea has been advanced that the deterioration of wheat in some of the older wheat-growing sections is due to the accumulation of various disease-producing fungi in the soil and in the seed. No one particular form can be mentioned as being responsible for the damage. A number of different ones contribute to cause the decrease in yield and the deterioration in the quality of the grain. The action probably goes on somewhat as follows:

After wheat has been grown on the same land year after year, various fungi which are able to attack it only slightly accumulate in the soil; they gradually acquire the power of attacking the wheat more severely, until finally they may attack the young seedlings or the plants which have reached a later stage of development. They may prevent the proper stooling, may cause the blight of leaves, and may even get into the kernel. Wheat seed from such fields would then be unfit for planting even on clean soil, since it would merely carry the disease to the new soil. The methods of control consist very largely in soil sanitation, and proper rotation of crops should be maintained—a rotation which provides for some other crop than a cereal crop. As an added precaution the seed should be treated as for stinking smut. It is claimed that by this proper rotation and the seed treatment the yields can be very materially increased.

Scab—Scab on wheat is usually recognized on the kernel and chaff. It shows as a pink mucilaginous mass which quite often cements the chaff together. It is also claimed by some that the same fungus causes a seedling disease of wheat and possibly also of some of the other grains. If it appears as a seedling disease, the seedling may be either

killed or very much weakened; if it attacks the young kernel and the chaff, the kernel may be very greatly shriveled and in some cases the entire head rendered worthless. It is by no means a disease of secondary importance, becoming very serious in a great many cases. The best method of treatment is to clean the grain very thoroughly in order

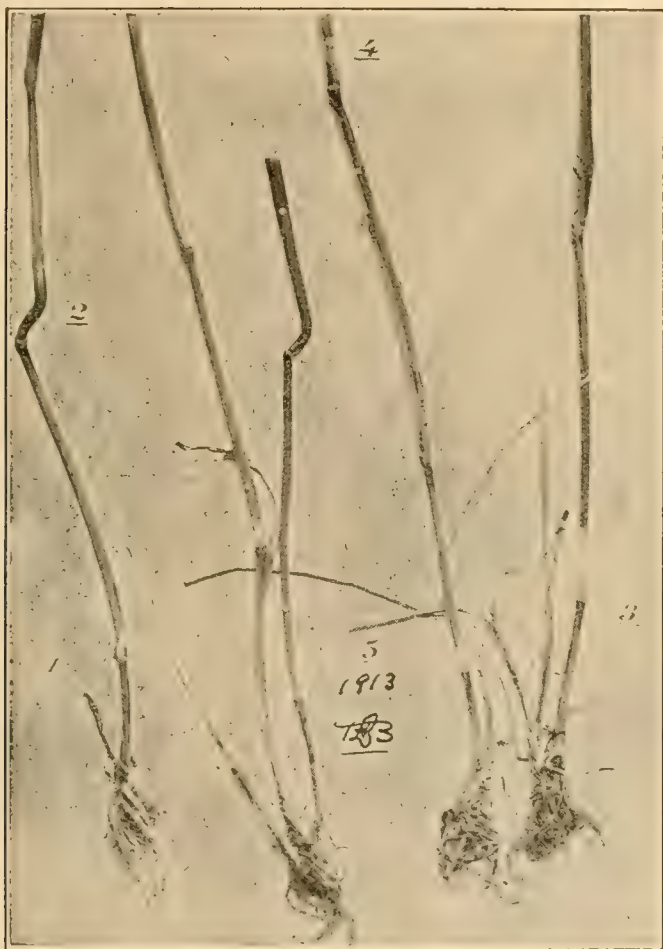

Fig. 2.—Crinkle Joint or Break-Over. Stools of wheat, taken from wheat-sick soil. Big swelling and dark markings around the second or third joint from the seed. Blighted stool at the base of the plant. Condition is not due to insects or weather. Courtesy of the North Dakota Experiment Station

to get rid of the scabby kernels, which are usually much lighter than the healthy ones. As an added precaution the formaldehyde treatment might be applied. However, the most important thing is to get rid of the light, shriveled kernels.

OATS

Rust—Two rusts occur on oats, leaf rust and stem rust. The same things which were said of wheat rust apply in general to oat rust.

Nothing more can be said of the methods of control, and the only hope of controlling the disease probably lies also in the production of resistant varieties.



Fig. 3.—Smut of Oats; normal head on the left, smutted head on the right.
Courtesy of the Minnesota Experiment Station

Smut — (See Fig. 3). In general the life history of the smut of oats is the same as that of the bunt of wheat. There are minor variations which, however, are not important from the point of view of methods of control. The smut can be controlled almost perfectly by means of the formaldehyde treatment. The directions given for the formaldehyde treatment of wheat should be followed in treating oats.

Blade Blight or Blast—The blade blight or blast has been described only quite recently. The signs of the disease are as follows: The plants attacked in the seedling stage may become yellowish in color; sometimes yellow stripes may follow the stem and extend out to the tips of the leaves. They are sometimes indefinite; usually they start in the blade and work back into the stem. It is probable that the disease sometimes starts in the roots or in the stem at the ground line. In old plants, all of the leaves may sometimes be affected and be almost completely destroyed. Very frequently the yellowish color of the leaves changes to a brownish or reddish color, together with a certain amount of spotting. Quite often when the entire field or large areas of the field are affected, the injury may be so severe as to cause the appearance of a very severe rust injury. The heads are also affected; in very severe cases, they cannot push out of the sheaths at all, while in other cases the kernel may become very much shriveled and the entire head appear white. The disease is caused by two kinds of bacteria. There is not much to be said concerning the control of the disease. It is possible that resistant strains of oats may be found. However, up to the present time, this has not been accomplished.

Weather conditions determine to a large extent whether or not the disease will be serious. During rainy and cloudy weather the disease is apt to be very much worse than under other conditions. It very probably spreads from plant to plant, largely as a result of the spattering during a rain. It is said that thorough drainage will tend to decrease the amount of the disease to a certain extent. Aside from this, little can be said concerning its control.

Seedling Diseases—In general the same thing may be said about seedling diseases in oats as was said concerning the same class of diseases of wheat. A number of different fungi may be responsible for various seedling diseases. The same method of procedure in general should be followed as was recommended for wheat—soil sanitation coupled with careful seed selection, and, when necessary, seed treatment.

BARLEY

Rust—Practically the same things which were said about the rust of wheat and oats can be said about the rust of barley. Here, again, there are two rusts, the stem and leaf rust, of which the stem rust does the greater amount of damage. Methods of control are as imperfectly worked out for barley rust as for the others, and nothing can be said concerning them except that the only hope lies in the production of resistant varieties.

Smut—There are two smuts of barley, corresponding roughly with those of wheat. The life history and method of treatment for the loose smut of barley corresponds in general with that of loose smut of wheat,

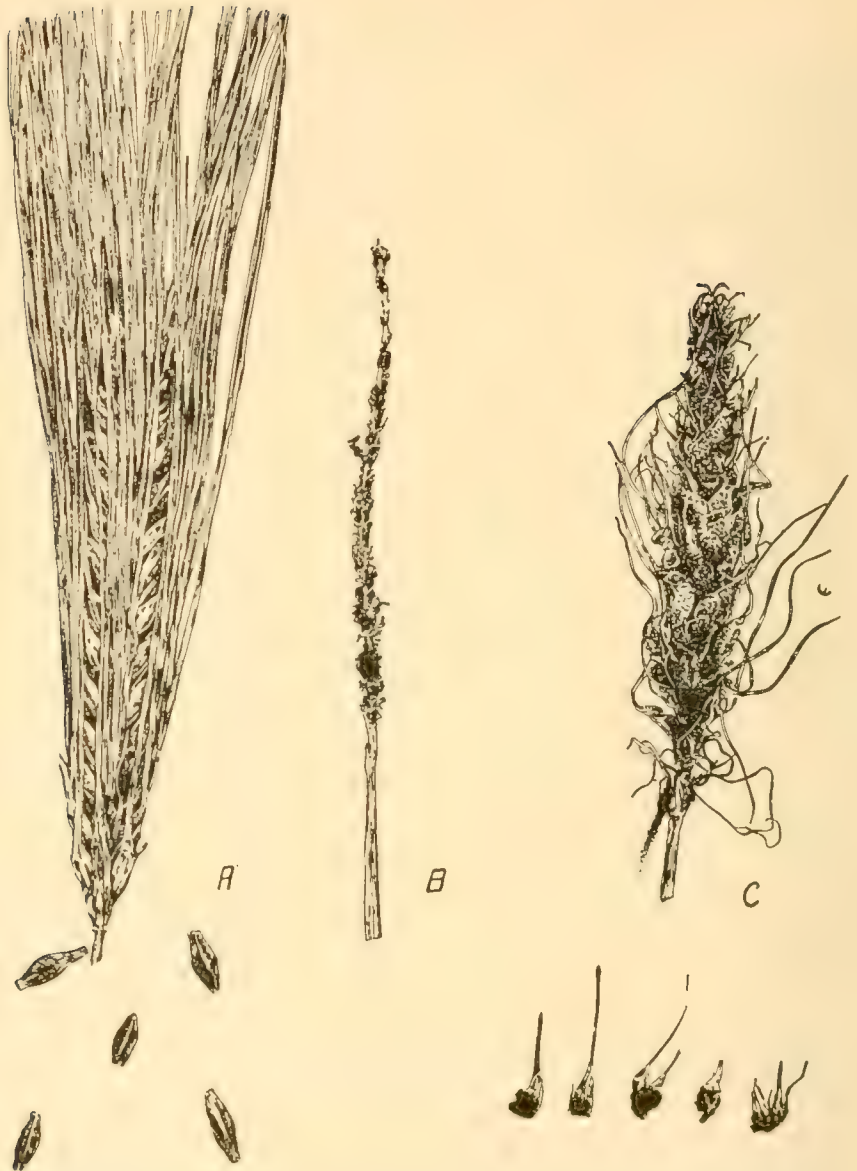

Fig. 4.—The Smuts of Barley. *A*, Healthy head of barley. *B*, Loose Smut; note that the smut powder has blown away leaving only the naked stalk. *C*, Covered Smut; the kernels are reduced to a smutted mass, but the smut powder remains in a firm mass.

Courtesy of the Minnesota Experiment Station

while the covered smut of barley corresponds in general with the bunt of wheat. The two can be distinguished in the field in the following way: The spore mass of the loose smut is dry and powdery and blows away very easily, leaving only the naked stalk. In the case of the covered smut, however, the smut mass is usually covered at first and sometimes for a considerable length of time by a delicate grayish membrane. The smut powder is not so dry and does not blow away nearly so easily, sometimes remaining on the stalk for a considerable length of time. A good idea of the difference in the two can be had by referring to Fig. 4.

It is essential that the farmer recognize the difference between the two diseases since they require different methods of treatment. The treatment of the loose smut is the same as that for the loose smut of wheat except that the grain should be immersed in water kept at a temperature of 52° Centigrade (125.6° F.) for fifteen minutes. If the temperature should rise above 52° C. (125.6° F.) the time of immersion should be reduced to ten minutes at 53° C. (127.4° F.) or five minutes at 54° C. (129.2° F.). The temperature should not exceed 54° C. (129.2° F.). If the temperature should fall below 52° C. (125.6° F.) the time of treatment should be increased. The temperature should not fall lower than 51° C. (123.8° F.). The treatment for the covered smut of barley is the same as that for bunt of wheat and for the smut of oats.

Stripe Disease—The stripe disease of barley is quite often severe in barley-growing districts. The disease shows more particularly on the leaves, forming long brownish stripes with a pale border. These stripes quite frequently extend the entire length of the leaf. The damage comes about as a result of the destruction of some of the seedlings and also of the decrease in vigor of the plant, resulting in improper filling of the head and light kernels. The disease is caused by a fungus, the spores of which very probably adhere to the seed, and it is therefore recommended in controlling the disease that the seed be carefully cleaned and graded and treated with formaldehyde. It has been shown that soaking the seed for two hours is very effective. The hot water treatment recommended for loose smut also prevents this disease.

RYE

Rust—The same things which were said about the rust of the other cereals apply to rye.

Smut—The smut of rye is a leaf smut rather than a head smut. It is not always serious but when it becomes prevalent it may cause a considerable amount of damage. It can be recognized by dusty black masses of spores which occur on the leaves and stems, quite often at the joints. While it does not directly affect the kernel it may cause considerable loss by decreasing the vigor of the plants. When it is



Fig. 5.—Ergot of Rye; note the black horn-shaped bodies in place of kernels.
Courtesy of the Minnesota Experiment Station

severe the formaldehyde treatment as applied for bunt of wheat should be used.

Ergot—The ergot is a disease which is probably familiar to all who have had any experience in growing rye. In place of the kernel a long, hard, purplish-to-black body of horn-like consistency is produced. The disease is caused by a fungus and these hard bodies serve to tide it over the winter. They live in the soil and germinate in the spring, especially when they are near the surface of the soil; the disease again spreading to the young rye plants, getting into the very young kernels and again changing them into the ergot. The best methods of control are to clean the seed thoroughly in order to remove as many of the resting bodies of the ergot as possible, and to plow deeply in order to turn under as far as possible those which are left in the soil. The land if very thoroughly prepared will be less conducive to the spread of the ergot than when poorly prepared. The losses from ergot are usually not great. However, if cattle eat large quantities of grain or grass containing ergot it may cause the characteristic symptoms of ergot poisoning. If any of the wild forage grasses become affected seriously, they should not be used for grazing purposes. The grass may sometimes be mowed with the mower, having the blade set high. In this way the heads will be removed and thus the greatest amount of danger to stock will have been obviated.

FLAX

Rust—The life history of the rust of flax is somewhat different from those of other cereals. The rust in this case attacks only the flax plants and produces all of its different spore-forms on various parts of the plant. It is sometimes very destructive, but nothing more can be said about methods of control than can be said about the methods of control of cereal rusts. Resistant varieties may be resorted to where such can be obtained, but this, aside from the possible value of drainage in low-lying areas, is all that can be recommended.

Wilt—Wilt is one of the most serious of flax diseases. The young plants are attacked just as they come from the ground and may be killed immediately, or may be weakened to such an extent that they never reach maturity; if they do reach maturity they may always appear weak and sickly and produce few and light seeds. The disease is of fungous origin and may be either in the soil or on or in the seeds. For this reason two factors must be taken into consideration in controlling: first, the seed must be very carefully graded in order to eliminate the light and shriveled kernels, bits of straw and chaff which very frequently serve to carry the disease into new land, and then it should be treated with formaldehyde as for bunt of wheat.

In treating flax the sprinkling method is very frequently used. After the seed is carefully cleaned and treated it must be sown on clean land

or the resulting crop may again be affected with wilt. Flax should not be grown on the same soil more than once every five or six years. By these two methods, the losses from the wilt can be almost entirely eliminated.

CORN

Smut—The corn smut is different from any of the other smuts previously described. It may attack the corn plant at any stage of its growth, provided there is young growing tissue present. The spores may live for years in the soil, or in the compost or manure pile, especially if animals have been fed smutty corn. It has been shown some years ago that for this reason the use of fresh manure on corn land should be avoided. There seems to be good evidence that the spores of the smut are destroyed in the silo. As far as practical methods of control are concerned, none which are absolutely satisfactory can be given. A rotation of crops together with the avoidance of fresh manure on the corn land, and the removal and burning of the so-called smut boils of the plant, are the only measures which can be recommended. These measures, if practised by everyone in the corn growing section, would probably in time reduce the amount to a minimum. When they are carried out, however, by an individual



Fig. 6.—Corn Smut. The ear reduced to a smut mass. The leaves may also be affected.

Courtesy of the Minnesota Experiment Station

farmer, although they may reduce the amount of smut to a certain extent, they will not control it entirely.



POWDERY SCAB

Starts under skin like blisters, which break showing dark powdery masses.



BLACK SCURF

Dark specks on skin, developing into irregular, raised masses, shiny black when wet, like "dirt that won't wash off."



COMMON SCAB

Starts on surface. Rough scabby spots, often deepened by worms.



SILVER SCURF

Dark blotches which later may turn silvery gray. Skin shrivels in storage.



BLACK LEG AND ROT

Base of stalk black, rotten. Top spindling, yellowish, dies early. Soft rot of tubers.



LATE BLIGHT AND ROT

Late blight starts on leaves, followed by dry rot or wet rot of tubers, beginning at surface.

PLATE 33

CHAPTER II

DISEASES OF THE POTATO, ALFALFA AND CLOVER

I. POTATO—EARLY BLIGHT—LATE BLIGHT—TIP BURN—FUSARIUM WILT—ROSETTE, RHIZOCTONIA—BLACKLEG—SCAB—ROTS—GENERAL SUGGESTIONS FOR THE PREVENTION OF POTATO DISEASES. II. ALFALFA—LEAF SPOTS—WILT—ANTHRACNOSE—PSEUDOMONOSE. III. CLOVER—RUST—ANTHRACNOSE—BLACK MOULD—WILT—LEAF SPOTS.

POTATOES

Early Blight — Early blight is a foliage disease. It affects only the leaves. It can be recognized by the concentric circles which are formed in the diseased areas (see Fig. 7). The spots may at first be small, but they may grow to such an extent as to affect the entire leaf. The loss comes about as a result of decreasing the leaf area and thus decreasing the yield. The disease can be entirely controlled by means of proper spraying methods. For spraying, Bordeaux mixture of the 5-5-50 formula is the most effective. It is sufficient in controlling this disease, to begin spraying when the first signs of the disease appear on the early varieties. However, this is sometimes not a safe process, since the disease may be already fairly widespread before it is noticed. The spraying should be very thorough and should preferably begin when the plants are about eight inches high and be repeated at intervals of ten days or two weeks, depending on weather conditions, until the vines ripen. In regions where late blight is prevalent, this spraying should by all means be followed out since it will control both the early blight and the late blight. It has been pretty well demonstrated that it pays to spray potatoes with Bordeaux mixture even when diseases are not very severe, since the yield is increased very materially under average conditions as a result of the spraying. For details of making Bordeaux mixture see paragraph on the subject under "Diseases of Orchard Crops."

Late Blight — Late blight in the northeastern potato-growing states of the United States is the most serious disease with which the potato growers have to contend. In the central western states where the climate is usually drier it is not so severe. However, it may become very serious in these states also. The destructiveness of the disease depends to a great extent upon weather conditions. It is most apt to be serious in periods of moist, fairly warm but not hot weather. A few days with
1 weather conditions may be sufficient to enable the disease to spread over almost an entire field and cause a tremendous amount of



Fig. 7.—Early Blight of Potatoes. Note the spots with concentric circles. This is characteristic of the disease. Compare with Fig. 8, Late Blight.

Courtesy of the Minnesota Experiment Station

damage. It can be distinguished very easily from the early blight. Under average conditions it does not appear in the central western states until after the middle of August. The signs of the disease may be noted on the leaves and tubers. On the leaves the spots appear first as purplish, water-soaked areas, usually at the tips first. There is, however, no tendency towards the formation of the concentric circles which are mentioned in connection with the early blight. These diseased areas may increase in extent until the entire leaf is affected. If the weather continues to be moist, white mould-like tufts of the fungus may appear on the leaves; if, however, the weather becomes hot and dry, the disease will be checked in its spread, but the leaves already affected will turn brown and dry. The fungus attacks not only the leaves but the tubers as well; it spreads from the leaves to the tubers, probably very largely by means of the spores dropping to the ground. It can be recognized by the sunken purplish or brownish patches and the dry tissue beneath the cork. In wet weather a soft, foul-smelling rot may occur. The rot may spread in storage and cause a great deal of damage, not only on account of its own activities, but also because it may pave the way for the entrance of other fungi and bacteria, which often cause the soft foul smelling rot of the potatoes. The disease can be controlled almost absolutely by means, first, of the selection of disease-free tubers, and second, by means of very thorough spraying, beginning when the plants are six to eight inches high and keeping the vines well covered with 5-5-50 Bordeaux mixture throughout the season. The thorough-



Fig. 8.—Late Blight of Potato, diseased areas appearing at the margins of the leaves. Note the absence of concentric circles. Compare with Fig. 7, Early Blight.

Courtesy of the Minnesota Experiment Station

ness of the spraying should be emphasized. Most farmers do not spray thoroughly enough. Mere sprinkling of the vines is not sufficient; they must be covered and must be kept covered with Bordeaux mixture if they are to be protected. A long series of spraying experiments in the northeastern states has demonstrated very thoroughly that the disease can be controlled, and that yields can be increased by as much as two hundred bushels per acre as a result of careful spraying. The disease does not appear in serious form every year; but as a matter of insurance, potatoes in regions where this and early blight are apt to become serious, should be sprayed thoroughly each year, since it has been shown under a large number of different conditions that it is a paying operation.



Fig. 9 —Fusarium Wilt. Note the vines on the left. They have completely collapsed; normal plant on the right.

Courtesy of the Ohio Experiment Station

Tip Burn—Tip burn can be easily recognized by the drying out of the tips and margins of the leaves. It is different from early blight in the fact that there are no concentric circles produced, and is different from the late blight in the fact that the leaf areas involved are not purple and do not show a tendency to produce a white mould in moist weather. Tip burn is not caused by any parasite; it is simply a drying out of the tips and edges of the leaves. It is usually most serious when periods of extremely hot dry weather follow periods of moist cloudy weather. It is also worse on light sandy soil, other things being equal, than it is on heavier soils. No very definite remedies can be prescribed. Good cultural conditions are, of course, essential. The spraying as practised for

early blight and late blight tends to decrease the amount of tip burn to a certain extent. This is probably due to the fact that spraying with Bordeaux mixture has a stimulating effect on potato vines for which it is valuable in addition to its value as a preventive of the two blights.

Fusarium Wilt—Fusarium wilt is sometimes extremely serious. The plant when young may become yellowish in color, the leaves may roll inward and the branches may point upward giving the entire vine a compact appearance. This, together with the very distinct yellowing of the leaves, is quite characteristic. Eventually the vines collapse and the wilting is complete, the death of the vine following very shortly.

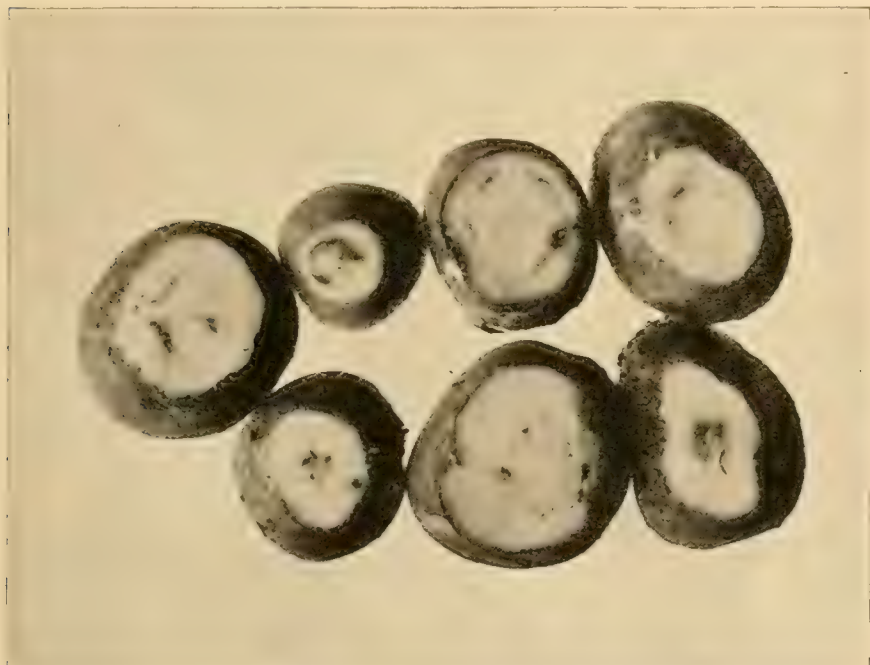

Fig. 10.—Fusarium Wilt tuber ring discoloration. The area of the sap tubes is distinctly browned. Such potatoes should never be planted. They produce diseased plants such as are shown in Fig. 9.

Courtesy of the Minnesota Experiment Station

The vines may be attacked at various stages of development. The result, however, is in most cases the same, except that when rather old vines are affected they are not necessarily killed outright. The disease is caused by a fungus which may get into the roots of the potato plant either from the soil or from diseased tubers. It then works up into the stem and shuts off the water supply; it also destroys or weakens some of the tissues of the stem causing the plant to wilt and drop over. It may travel back through the tuber-bearing stems into the tubers themselves. Such affected tubers, when examined, show a brown ring discoloration near the stem end. This can be seen very clearly by cut-

ting a thin slice off from the stem end. If the potatoes are badly affected a very distinct brown ring may appear; in other cases, however, the ring may not be so distinctive. When looking for this discoloration, care should be taken to cut deep enough to get beyond the natural yellowing which is characteristic of some varieties.

The methods of control are fairly simple, although they require a great deal of care. Naturally, since the fungus may live over, either in the soil or in diseased tubers, precaution must be taken to plant clean tubers on clean soil. This involves seed selection and rotation of crops. Clean seed can be obtained only by getting it from fields which are known to have been free from the wilt, or by cutting a thin slice from the stem end of seed tubers and rejecting all of those which show the discoloration. In making this examination, the knife which is used should be dipped each time after a diseased tuber is cut, into corrosive sublimate solution made up at the rate of one part of corrosive sublimate to a thousand parts of water. Directions for making up this solution are given later. After the seed tubers have been carefully selected they should, as an added precaution, be treated either with formaldehyde or with corrosive sublimate. This seed treatment cannot be relied upon to get rid of the infection in the tubers. Therefore, as far as wilt is concerned, the essential thing in getting clean potatoes is to get rid of all those which show the brown discoloration. After the potatoes have been thus selected and treated they must be planted on clean soil — that is, soil which has not produced a crop of diseased potatoes in the immediate past. Potatoes should not be grown on the same soil more than once every five or six years if there is any tendency for disease to accumulate in the particular region in which they are grown. It is difficult to say just how long traces of infection may remain in a badly infected field. However, the time intervening between two successive crops of potatoes should be as long as possible.

Rosette, Rhizoctonia — Rhizoctonia like Fusarium wilt, attacks both vines and tubers. Affected plants may first appear as green as healthy ones but there is usually a tendency for the leaves to roll and for the branches to grow straight upward, forming a very decided rosette appearance. The injury to the vines varies greatly; sometimes the plants are stunted very shortly after the germination, of the potato to such an extent that they never mature at all. In extreme cases small tubers are formed on the vines or just about at the ground line; this is due to the fact that the fungus attacks the roots and destroys the tissues through which the material which forms the starch in the tubers would normally pass. On pulling up diseased vines one can usually see the brownish or black areas on smaller or on large roots. (Fig. 11.) Often near the ground line a grayish powdery mass appears on affected vines, but this is not always the case. The fungus gets on the tubers also,

forming little brownish or black patches of fungous felt, varying in size from the size of a pin head to that of a wheat kernel. It is in these patches or resting bodies that the fungus lives during the winter. (Fig. 12.) Affected tubers should therefore never be used for seed. The meth-



Fig. 11.—Potato Rosette (*Rhizoctonia*). The vines are abnormally compact. The brownish or black discolored areas on the roots are characteristic. The fungus has caused a dry rot of the main root of the plant shown in the middle.

Courtesy of the Minnesota Experiment Station

ods of control are fairly simple. In this case a seed disinfection will rid the tubers of the fungus since it is a superficial one. When the tubers have been treated they should be planted on clean soil, that is, soil which has grown some crop which has not been affected by the fungus

for a number of years previous. In regions where the *Rhizoctonia* causes great losses cereal crops should be used in rotation. For treating the seed tubers, corrosive sublimate is the best substance. Details of this treatment are given in the general recommendations for control of potato diseases.

Rhizoctonia is one of the serious diseases in some potato-growing regions. This is especially true on account of the fact that it causes a great deal of injury which is very often not recognized as fungous injury at all. Uneven stands in potatoes and missing hills can very frequently be traced to the injury from this source.

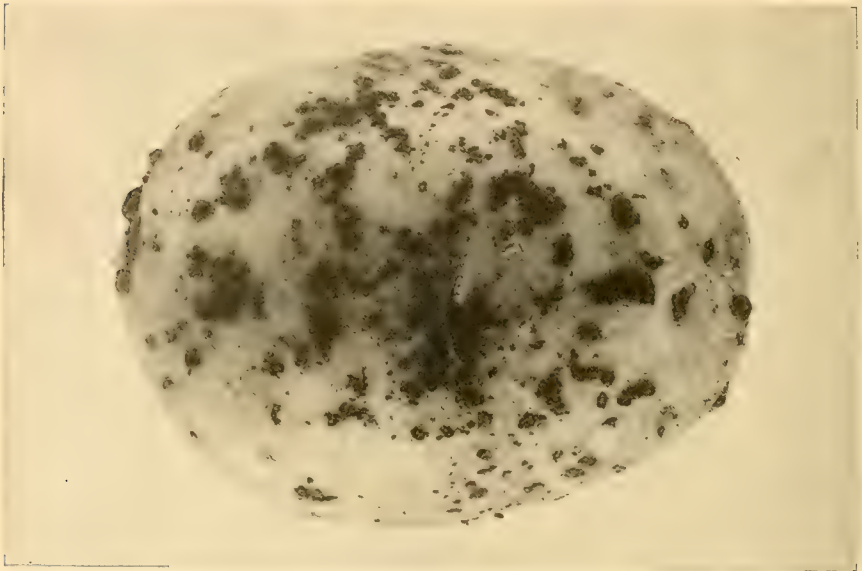

Fig. 12.—*Rhizoctonia* on potato tubers. The fungus overwinters in the small black bodies on the surfaces of the potatoes.

Courtesy of the Maine Experiment Station

Blackleg—Blackleg is a disease of bacterial origin which attacks both the vines and tubers. It gets into the field very largely, or perhaps entirely, as a result of planting diseased tubers. Affected plants may at first appear spindling and yellowish in color. The plant may break over and die; in all cases a black discoloration is apparent, either near the ground line or in some cases above it. The tissues in these discolored areas are soft and rotten. The seed pieces under such plants are also rotted. The bacteria may get into the tubers and cause a soft rot. When such tubers are again used for seed the next year the resulting plants will be diseased. It is of the greatest importance therefore that only clean seed be used. If the general recommendations for controlling potato diseases are followed all these diseased tubers should be eliminated. As an added precaution, after seed selection the

seed should be treated with either formaldehyde or corrosive sublimate. So far as is known the bacteria which caused the disease do not live over winter in the soil. However, for other reasons, some of which have already been mentioned, a rotation should always be practised in growing potatoes.

Scab—Every potato grower is familiar with the common scab. The dry corky patches which are formed on the tubers are characteristic, the entire tuber sometimes being deformed. Scab is caused by a bacterial parasite which probably lives in most rich soils and attacks potatoes and other root crops when the conditions for its growth are favorable. These conditions are much humus and alkalinity of the soil. Clean potatoes grown in such soils sometimes become scabby. However, if the land is entirely clean, the scab may also be introduced into the land by means of scabby seed potatoes. Therefore, in attempting to prevent scabby potatoes, four things should be taken into consideration: first, the seed tubers should be disinfected in the manner recommended at the end of the discussion of potato diseases; second, a proper rotation should be maintained, as has already been recommended for other diseases; third, fresh barnyard manure should not be put on soil which is to be used for growing potatoes; fourth, the soil should be kept neutral or slightly acid in case the scab is serious. This acidity can be maintained by using green manure, that is plowing under clover or other crops of like nature.

Rots—A tremendous amount of loss is caused each year as a result of various tuber rots. These rots fall into two general classes, dry rot and soft rot. The rots caused by the late blight fungus and by the blackleg bacterium have already been mentioned. There are various other, dry and soft rots caused by a number of different fungi and bacteria. The precautions which should be taken to guard against these are in general the following:

1. Plant only good, healthy seed.
2. Avoid bruising the tubers at digging time or in shipping.
3. Maintain proper storage conditions—that is, keep the potatoes in a place where the temperature can be maintained as near the freezing point as possible without actually freezing them. Good ventilation should also be provided.
4. Practise a crop rotation such as has already been advised.

General Suggestions for the Prevention of Potato Diseases—The essential facts to be remembered in preventing potato diseases are:

1. Clean seed must be planted.
2. This seed must be planted on clean land.
3. The foliage should be protected during the growing season from leaf fungi.

This involves three different lines of work—seed selection and dis-

infection, crop rotation, and spraying. In selecting seed potatoes, only those which are true to type, free from any external or internal rots and free from the brown ring discoloration, should be kept for planting. Then after they have been selected they should be disinfected either in formaldehyde or in corrosive sublimate. In treating with formaldehyde, a mixture is made up at the rate of one pint to thirty gallons of water and the tubers are kept in this solution for two hours. They may then be cut and planted immediately or may be kept indefinitely providing they do not come in contact with anything which has contained scabby potatoes. If corrosive sublimate is used, four ounces should be dissolved in about five gallons of hot water and allowed to stand for some time. Then enough water should be added to bring the total up to thirty gallons. Tubers should be soaked in this solution for one and one-half hours when they may be cut and planted or kept until planting time. It should be remembered that corrosive sublimate is a deadly poison and may lead to fatal results if taken internally. However, it is not at all poisonous on the skin. It should not be placed in metal tubs or vessels of any kind, since it corrodes the metal. Only wooden barrels or tubs should be used. There is very good evidence that the corrosive sublimate treatment is much more effective than the formaldehyde treatment in killing the resting bodies of *Rhizoctonia* on the surfaces of the tubers; therefore, if there is *Rhizoctonia* on the seed tubers, or if there is any reason to suspect that it may have been present in the preceding crop, corrosive sublimate should be used instead of formaldehyde. Otherwise formaldehyde is as effective as corrosive sublimate.

After the seed potatoes have been carefully selected for type and freedom from any diseases and have been disinfected, they should be planted on soil which has not grown potatoes for five years or longer. It would be preferable to plant them on soil which has not grown root crops for more than five years previously, especially in localities where scab and *Rhizoctonia* are prevalent. Then the foliage should be protected during the growing season. In addition to the Paris green or arsenate of lead which are used for killing the potato "bugs," Bordeaux mixture of 5-5-50 strength should be applied often enough to keep the leaves well covered with it. This does not necessarily involve any great amount of additional labor since both spraying materials may be applied at the same time. Then when the potatoes are dug and handled, before putting them into storage, care should be taken not to bruise them any more than is absolutely necessary.

Directions for making Bordeaux mixture are given with the discussion of fruit diseases.

ALFALFA

Leaf Spots—There is more than one leaf spot, any of which may sometimes be found to a considerable extent on alfalfa. Sometimes

they may be serious enough to cause large numbers of the leaves to drop. The only possible method of control is to cut over the field in the hope of getting rid of a large number of the diseased leaves. Quite often it is possible to cut over in this manner just before cutting time, in the hope that the new shoots will be free from the disease.

Wilt—The wilt can be distinguished by the drooping of the leaves which quite often become matted together and may be covered with a white mould-like growth. Small black resting bodies of the fungus may also be observed on these diseased parts. If the disease is serious, a crop rotation is probably the only thing which will control it.

Anthracnose—The disease can be recognized by grayish sunken spots on the stem; small black eruptions quite frequently show on these sunken spots. The use of resistant varieties is the only remedy.

Pseudomonose—Pseudomonose is a disease of bacterial origin. It causes watery, yellowish to olive green spots on the sides of the stem. These spots may later become much darker, sometimes being black in color. No definite control measures have as yet been worked out.

CLOVER

Rust—The rust of clover is a true rust which may sometimes become very serious. No definite methods of control have as yet been worked out.

Anthracnose—(See Alfalfa).

Black Mould—This disease resembles rust quite closely. Pale spots may appear on the upper surface of the leaves and on examination these will be seen to be black on the lower surface. No treatment is known.

Wilt—(See Alfalfa).

Leaf Spots—(See Alfalfa).

CHAPTER III

DISEASES OF ORCHARD AND GARDEN CROPS

- I. ORCHARD CROPS—GENERAL STATEMENT—PREPARATION OF BORDEAUX MIXTURE—LIME SULPHUR—PRECAUTION IN SPRAYING—**Apple**—SCAB—BLACK ROT—BITTER ROT—RUST—FIRE BLIGHT—CANKERS—**Plum and Cherry**—BROWN ROT—PLUM POCKETS—SHOT HOLE. II. SMALL FRUITS—**Raspberry**—ANTHRACNOSE—CANE BLIGHT—CROWN GALL—YELLOWS—RUST—LEAF SPOT—**Blackberry**—**Strawberry**—LEAF SPOT—**Gooseberry**—POWDERY MILDEW—LEAF SPOT—**Currant**—LEAF SPOT—**Grapes**—DOWNY MILDEW—BLACK ROT—POWDERY MILDEW. III. GARDEN AND TRUCK CROPS—**Bean**—ANTHRACNOSE—BLIGHT—POWDERY MILDEW—STEM ROT—**Tomato**—BLACK ROT—POINT ROT—LEAF SPOT—**Cucumbers**—WILT—NUBBIN—**Cabbage**—BLACK ROT—CLUB ROOT—YELLOWS—**Pea**—LEAF SPOT—POWDERY MILDEW—SOFT ROT OF VEGETABLES—CONCLUSION—SUMMARY OF METHODS OF CONTROL.

ORCHARD CROPS

General Statement—As is the case with most of the serious diseases previously mentioned, diseases of orchard crops are very largely caused by fungi and bacteria. The methods of controlling them are necessarily somewhat different. Spraying and pruning are, of course, the two methods usually resorted to. On account of the fact that spraying is absolutely essential in controlling most of the serious diseases, the formulas for making up the various spraying mixtures may be given here. The two fungicides (substance which will kill fungi) most used in spraying fruit trees are Bordeaux mixture and lime sulphur solution. In general they are probably very nearly equally effective, although there are exceptions to this statement. However, lime sulphur, on account of its convenience and on account of the fact that it can be used on peaches and plums without much danger of injury, is coming continually to be more used.

Preparation of Bordeaux Mixture—Bordeaux mixture is made of bluestone (copper sulphate) and quicklime. In making it the two should be dissolved separately. The bluestone should be put into a coarse gunny sack and suspended in water, since it does not dissolve very readily. The lime should be slaked and then diluted to the proper amount. Then the two liquids are poured together. The best way of doing this is for two people to work together, one pouring the lime water and the other the copper sulphate solution in such a way that they mix in the pouring. Bordeaux mixture is used in various strengths; its strength being expressed by its formula, for instance: 5-5-50 means that 5 pounds of copper sulphate, 5 pounds of lime and 50 gallons of water have been used in making the mixture. In making 5-5-50 Bordeaux mixture, 5 pounds of copper sulphate should be dissolved in 25 gallons of water and 5 pounds of good quality quicklime

should be slaked and then diluted sufficiently to bring the total amount of water up to 25 gallons, and then the two liquids should be mixed in pouring. 3-3-50 Bordeaux mixture means that 3 pounds of copper sulphate, 3 pounds of lime and 50 gallons of water were used in making the mixture in the manner just described. The number of pounds of copper sulphate is indicated by the first figure, the number of pounds of lime by the second and the number of gallons of water by the last.

In making large quantities of Bordeaux mixture a stock solution of copper sulphate and a stock solution of lime water may be made up and then kept separately until ready to be used. These stock solutions are made up by dissolving copper sulphate in water at the rate of 1 pound of copper sulphate to 1 gallon of water, the lime water being made in the same proportions. When they are ready for use the mixture can be made in the same way as described previously.

Lime Sulphur—Three general forms of lime sulphur are used, the concentrated, the diluted and the self-boiled. The first two are the same, except that the first is stronger than the second. The lime sulphur can be bought in bulk and in making the concentrated solution 1 gallon of the lime sulphur is used with about 9 gallons of water. This is used only when trees are not in leaf. The diluted mixture is made by adding one gallon of lime sulphur to thirty-five or forty gallons of water. The self-boiled lime sulphur is used on peaches and other fruits which are very liable to injury as a result of spraying. In preparing it 8 pounds of lime, which must be of very good quality are slaked and 8 pounds of sulphur added while the lime is slaking. The heat of the slaking lime cooks the sulphur. The process usually goes on for about fifteen minutes, although this time may be reduced to ten minutes or even less, if the lime slakes very quickly. Care should be taken to have all the lumps of the sulphur broken up before it is added to the slaking lime. After the process is completed, a little water should be added and the mixture stirred thoroughly, and then enough water should be added to bring the total up to fifty gallons.

Precautions in Spraying—The success of spraying depends upon the spraying material used, upon the thoroughness of the application and upon its timeliness. In general, in spraying, a nozzle which produces a fine spray is preferable to one which throws the spray out in the form of small streams. However, the second type of nozzle may be more desirable when there is some necessity for making the spray penetrate into cracks of the bark or into calyx cups of apples. The leaves and fruit should, in all cases, be very thoroughly covered. Whenever spraying is not a success it can usually be attributed, provided it is done at the proper time, to lack of thoroughness.

The Apple

Scab—Apple scab is a fungus disease with which every fruit grower is familiar. The scabby patches and cracks on apples are very

frequently seen in commercial orchards and in smaller ones. However, it is probably not so generally known that the scab fungus also affects the leaves. On the leaves it may cause sooty or velvety spots varying in size. In extreme cases, practically all the leaf area may be affected and the entire tree may appear to have been slightly scorched. Under such conditions a good vigorous growth and production of a good crop are out of the question. Scab, under ordinary conditions, can be controlled by means of two or three sprayings. The first application should be made just at the time when the center blossom of the flower clusters begin to show pink. The trees should not be sprayed when the flowers are in bloom, because there is some evidence to show that the effect at this time may be injurious to bees. The second spraying should be made when about two-thirds of the petals have fallen. At this time the calyx cups have not yet closed and it is possible to kill the very young codling moths which are inside. These two sprayings will very frequently control the scab entirely. However, when moist and cool weather follows, a late infection of the scab may sometimes occur, necessitating a third spraying about two weeks after the second. For apples, either Bordeaux mixture or lime sulphur may be used. Arsenate of lead should be mixed with the lime sulphur or Bordeaux mixture in order to kill the insects.

Black Rot—Black rot is not as common in the Northwest as it is in some of the other apple growing sections. Usually it does not appear until much later in the season than scab. It is especially dangerous on account of the fact that it not only attacks the fruit and destroys it, but may also get into the twigs and young branches, causing very destructive cankers. When these cankers are formed, the bark becomes much wrinkled and greatly sunken around the edges. Very large wounds may result, the cankers often occurring on large limbs and sometimes even on trunks. In extreme cases the branches may be entirely girdled and killed. In any case the results are apt to be rather serious to the fruit. The rot, as the name indicates, is a black rot. It begins as a small brown spot, quite often near the butt end of the fruit. The color may then become much darker and small black eruptions are produced in the rotted areas. Methods of control consist in cutting out the cankers and in spraying. It is recommended that a good cleansing wash be given early in the season while the trees are dormant. For this purpose either the concentrated lime sulphur or copper sulphate, dissolved in water at the rate of one pound of copper sulphate to about ten or fifteen gallons of water may be used. A late summer spraying would probably also be of some value.

Bitter Rot—The bitter rot like the black rot, is not so common in the Northwest as it is in some of the other sections. It attacks both the fruit and the branches. It appears first as a small brown spot under the skin of the fruit. This spot then increases rapidly in size and the center becomes sunken. The entire fruit may be affected. In cases where the entire fruit is not affected, the part of the apple near the affected portion is very bitter,

thus giving the disease its name. During moist weather small waxy thread-like strings, which at first are pink but later become gray, may break through the skin of the apple. In controlling the disease, the affected apples should be removed and burned. All cankered limbs should be cut out. Following this the tree should be sprayed with a nozzle giving a mist-like spray. If the only serious disease in the apple orchard is the bitter rot, spraying may begin about six weeks after the petals have fallen, and then subsequent sprayings may be made as needed.



Fig. 13.—Fire Blight on apple twigs. The leaves have been killed but still remain on the twigs

Courtesy of the Minnesota Experiment Station

Rust—Apple rust affects leaves and fruit. It produces small yellow or honey colored cup-like structures with fringed edges. So many of the leaves may become seriously affected that the vigor of the tree is very greatly decreased. The damage to the fruit is largely as a result of the unsightliness of the spots. The spores which are produced on the apple get into red cedars and live there over winter. During rainy or wet weather the infection may again spread from the red cedars to the apples. Spraying

methods have not proved entirely satisfactory in controlling the rust. In regions where it is severe, and where the apple crop is of commercial value, red cedars should be cut out within one-half mile of the orchard.

Fire Blight— Fire blight is a bacterial disease which may get into the blossom, twigs, fruit and limbs and even the trunks. Usually, it appears first as blossom blight, and it is carried very largely by bees and other insects which visit the flowers; it then travels back into the twigs. The leaves become brown and die but do not fall from the twigs. The twigs themselves quite frequently become black. The bacteria may get into large branches or into the trunk through fruit spurs, water sprouts or suckers. They may then cause large cankered areas, in some cases even girdling branches and killing

them. In severe cases the entire tree looks as though the tips of the branches had been severely scorched, thus giving the name "fire blight." Spraying is of very slight value in controlling it. The affected parts must be carefully cut out and be kept cut out. In pruning out these affected parts, care should be taken to cut at least six or eight inches back from the point at which the disease shows on the surface. The pruning instruments should be disinfected after each cut with corrosive sublimate used at the rate of one part of the corrosive sublimate to one thousand parts of water. This disinfection may be accomplished either by keeping a cloth wet with the solution and swabbing off the instrument, or by dipping the instrument directly into the solution. All large wounds should be disinfected and covered with white lead or some good tree paint. The cultural conditions probably have something to do with the seriousness



Fig. 11.—Fire Blight cankers on apple branches. Notice particularly the large sunken canker on the largest branch. In the center of the dead area is a spur through which the blight entered. The color of the dead area is dark brown or black.

Courtesy of the Minnesota Experiment Station

of the blight. Anything which tends to promote succulent growth, also makes the condition for the spread of the blight better. Therefore, where the disease is severe, it would be desirable to withhold fertilizers, and probably even to refrain from cultivating during the period when the blight is spreading most rapidly.

Cankers—Cankers may be caused by a number of different fungi in addition to the bacteria causing fire blight. In general, when they occur in an orchard they should be cut out and the affected parts burned. It is of the greatest importance to protect all wounds and bruises on trees in order to prevent the entrance of the fungi which cause the cankers. Where there is a tendency for them to develop, careful and systematic pruning,



Fig. 15.—Brown Rot of plums. The plums have rotted and tufts of a tan colored powder can be seen on the surfaces.

Courtesy of the Minnesota Experiment Station

together with a cleansing wash when the trees are dormant, followed by proper spraying for the defense of the fruit will give the greatest protection.

The Plum and Cherry

Brown Rot—Brown rot is a fungous disease which attacks the flowers, leaves, fruit and twigs. Early in the spring at flowering time, the

fungus very often attacks the flowers and kills them, causing the so-called blossom blight. The petals become brown and the entire flower is killed. Later in the season, usually about ripening time, especially if the weather is warm and moist, the disease may spread with amazing rapidity, destroying a very large number of the plums. It may also attack green fruits, but usually only when it is injured, especially by punctures of curculio. On the fruit the disease causes a soft rot, brown in color with quite often tufts of a tan or ashy gray mould-like growth. See Fig. 15. It has been found that the disease can be almost entirely controlled by proper spraying methods together with the destruction of the diseased fruit. All of the so-called "mummies" (dried



Fig. 16.—Plum Pockets. The plums have been converted into a flabby, sack-like structure by the disease.

Courtesy of the Minnesota Experiment Station

rotted fruit) should be either collected and burned or plowed under deeply. At least three sprayings should be given, one at the time when the blossom buds are swelling, another when the young plums are about the size of peas and the last one about the time they are turning color and commencing to ripen. Arsenate of lead should be combined with a weak Bordeaux mixture (2-4-50) or lime sulphur in the first two sprayings; the last spraying may be made with Bordeaux mixture or lime sulphur alone. The addition of the poisons is of great importance since it kills the curculio which very frequently paves the way for the entrance of the fungus.

Plum Pockets — Plum pockets, bladder plums or fool's plums, are easily recognized on account of the fact that the pit is destroyed and the plums

instead of growing normally, produce large, sack like, soft, deformed fruits. (Fig. 16.) The disease is of fungous origin and persists to a great extent, as far as is known, in the plum twigs. Control measures have not been perfectly worked out; but indications are that pruning off the affected branches, together with very thorough spraying early in the season just before growth begins, and the destruction of the diseased fruits will reduce the losses very considerably.

Shot Hole—This disease attacks the leaves, causing small grayish to brownish dead areas which finally fall out, giving the leaves the appearance of having been riddled with buck-shot. It can be controlled by spraying as for brown rot.

DISEASES OF SMALL FRUITS

Raspberry

Anthracnose — Anthracnose can be recognized by the sunken grayish spots with purple borders on the canes and by spots of a similar nature on the leaves (See Fig. 17). Control measures consist in cutting out and burning the affected canes, and in extreme cases spraying with Bordeaux mixture to which resin has been added. The disease can be controlled fairly well in this way, if the spraying be thorough enough to cover the canes.

Cane Blight — Cane blight (see Fig. 18) can be distinguished from anthracnose in the fact that the canes wilt and the bark becomes grayish and peels off. In the grayish dead bark, small black eruptions can very frequently be seen. The wood is very frequently killed and distinctly discolored. Control measures are similar to those for anthracnose. Precaution should be taken to set out healthy plants, to avoid planting where raspberries have been grown before, and to remove and burn all of the affected canes, as well as the old ones, as soon as possible.

Crown Gall — This is a disease of bacterial origin which causes large tumor-like outgrowths at the crown or on the roots of the plants. Control measures are preventive in nature only. Clean plants should be set out on



Fig. 17.—Raspberry Anthracnose. The gray, sunken spots with purplish borders are very characteristic. Compare with cane blight which is shown in Fig. 18

Courtesy of the Minnesota Experiment Station

land which has not previously grown any crown-galled plants. The disease attacks a great many other plants also, but the indications are that less injury will follow by planting a different kind of fruit on an affected field rather than the same kind which has been grown there. It should be emphasized that it is essential to use only clean plants. Thorough examination should be made when the plants are ready for planting and only those which are free from suspicion should be set out.



Fig. 18.—Raspberry Cane Blight. Notice the gray bark which is peeling off. The spots are not definite as are those caused by anthracnose.

Courtesy of the Minnesota Experiment Station

should be removed and burned as soon as possible, since when the fungus once gets into the canes it remains there year after year. These canes are, therefore, worthless and should be removed and burned. For this reason spraying is of doubtful value, and the removal of the diseased parts must be relied upon.

Leaf Spot—There are a number of leaf spots on raspberry which sometimes assume considerable importance. Ordinarily, however, they do not do a great deal of damage. It is doubtful whether they are often of sufficient importance to warrant treatment. In case they are, however, the destruction of the dead leaves together with spraying would be the only practicable method of control.

Yellows—This is a disease which is not caused, as far as is known, by any parasite. It has been suggested that it is worse when plants are grown in very heavy soil. It can be easily recognized by the fact that the leaves show a tendency toward yellowing and curling. Under the circumstances control measures cannot be recommended.

Rust—The rust appears on the leaves as patches of orange colored powder. It is quite often noticed as soon as the young leaves appear in the spring. It is sometimes severe enough to involve practically the entire leaf. It decreases the vitality of the plant very greatly, causing it to grow in a spindling manner rather than normally. Eventually, the affected plants are usually killed. In any case, production of a normal crop is almost out of the question. All affected parts

Blackberry — (See Raspberry).**Strawberry**

Leaf Spot—The leaf spot of strawberry, which is characterized by spots with purple borders and grayish centers, sometimes becomes serious. In cases where the infection is rather severe the leaves should be cut in the fall and the patch burned over. In the spring spraying with Bordeaux mixture will help keep the disease in check if it is commenced early enough.

Gooseberry

Powdery Mildew—Powdery mildew may attack the leaves and the berries, rendering the berries worthless and decreasing the vigor of the plants. The disease can be controlled fairly well by means of thorough spraying. For this purpose liver of sulphur (potassium sulphide) is very effective. The spraying should begin when the leaf buds are beginning to unfold and should be continued at intervals of from ten days to two weeks. It is important to commence spraying early enough, since it has been definitely shown that the disease can thus be much better controlled than if the spraying is begun later. Potassium sulphide should be made up at the rate of one ounce of the sulphide to two gallons of water.



Fig. 19.—Crown Gall of Raspberries. Notice the tumor-like growth on the roots.

Courtesy of the Minnesota Experiment Station

Leaf Spot—The leaf spot is sometimes fairly severe, although under ordinary circumstances it does not do a great deal of damage. Destruction of diseased leaves, together with spraying will reduce the amount of injury very considerably. In this case, also, the spraying should be begun when the leaves are unfolding.

Currant

Leaf Spot—The leaf spot is sometimes serious enough to cause defoliation. Two of these leaf spots frequently occur, but control measures are the same. Bordeaux mixture should be used, beginning as soon as the leaves unfold and continued at intervals of from ten days to two weeks.

Grapes

Downy Mildew—Downy mildew appears on the leaves as whitish powdery patches usually on the lower surface. In severe cases the leaves may be almost entirely destroyed. It also attacks the berries, destroying them

entirely and causing a brown rot if it appears when the berries are nearly ripe. In order to control the disease, spraying must be practiced. This must be begun early and must be continued at intervals of about two weeks. Bordeaux mixture has proved very effective.

Black Rot — Black rot, as the name indicates, causes black or brown spots on the fruit. These spots increase until the berry is converted into a black, rotten mass. The berries then shrivel and become hard and dry. The leaves are also affected, small tan colored spots being produced. Small black eruptions, often arranged in concentric circles, can frequently be seen. Young shoots are also affected, reddish spots caused by the fungus appearing on them quite frequently. The rot is apt to be very much worse during warm, wet weather than in drier periods. It should therefore be guarded against during such weather conditions. All of the diseased fruit should be destroyed; clean culture should be practiced, including cultivation to destroy grasses and weeds, and plowing to cover all the remaining diseased leaves and berries. When the disease has been severe, a thorough spraying should be given while the vines are still dormant. When the vines are growing, Bordeaux mixture should be applied at intervals of about two weeks.

Powdery Mildew — Powdery mildew appears mainly on the leaves, although the other parts of the plant are also affected. It is different from the downy mildew, occurring on both the upper and lower surfaces of the leaf. The spots appear to have been dusted with flour. It can be controlled by means of flowers of sulphur in case the weather is rather hot. Where the weather is not hot and dry enough to make dusting with sulphur effective, Bordeaux mixture should be used.

DISEASES OF GARDEN AND TRUCK CROPS

Bean

Anthracnose — Anthracnose attacks the stems, leaves and pods. On the pods it causes large ulcer-like spots with fairly sharp borders. It is often found to be one of the most destructive of the common bean diseases. Control measures consist mainly in the selection of clean seed, since the disease is carried over in this way. Seed should be selected from fields which are known not to have had the disease, since a few infected seeds will very frequently produce a diseased plant and be the cause of spreading the disease to almost an entire field. If the disease appears during the growing season, great care should be taken to keep it from spreading. It spreads very rapidly during moist weather and the beans should never be cultivated at such times. In controlling the disease, clean culture should be practiced; this together with the selection of clean seed should keep it in check.

Blight — The blight attacks leaves, pods and stems. On the leaves, watery areas which are usually brownish in color are produced. These spots may dry, leaving thin papery areas. On the pods similar spots are produced. These spots can be distinguished from those caused by anthrac-

nose because they do not have such definite borders, and usually are not quite so sunken. The disease is carried over from season to season by means of infected seed. For this reason the greatest importance should be attached to the selection of clean seed. Seed treatment has been attempted for both the blight and the anthracnose, but, although the results have been good in some cases, it is doubtful whether or not it would be effective under all conditions.

Powdery Mildew—The powdery mildew may appear in serious form under certain conditions. Patches looking as though they had been dusted with flour, sometimes fairly large in extent, may appear. Spraying with liver of sulphur as for gooseberry mildew is effective.

Stem Rot—Stem rot may often cause damping off of seedlings; or it may appear on the stems when they are older, causing a dry rot. It may also appear on the pods, causing brown sunken areas. It sometimes gets into the seeds and is largely carried over in this way. The same precaution should therefore be observed as for anthracnose and blight—the selection of the seed.

Tomato

Black Rot—The black rot or ripe rot, attacks the fruit only when it is ripe. It is a typical rot, the affected areas quite frequently being covered with a dark brown or black felt-like mass. Control measures consist in trimming the vines so as to permit of proper ventilation and very thorough spraying with Bordeaux mixture.

Point Rot—The point rot appears first on green tomatoes. It appears usually at the blossom end, the fruit appearing as though it had been dipped into boiling water. Later the diseased area becomes darker in color. The cause is not definitely known, but indications are that the maintenance of proper soil conditions, including a sufficient amount of water, decrease the amount of trouble very considerably.

Leaf Spot—The leaf spot is sometimes serious. It is easily controlled by means of proper spraying methods. Bordeaux mixture has been found to be very effective.

Cucumbers

Wilt—Wilt is a bacterial disease which is spread very largely by biting insects, such as the cucumber beetle. The vines wilt as though suffering from loss of water. Proper control of the cucumber beetle will remove one of the chief carriers of the disease. Spraying with Bordeaux would, of course, be of little value. Pulling and burning all infected vines, together with crop rotation, will prove of some value.

Nubbin—This disease is variously referred to as nubbin, wart disease and tubercular disease. The cucumbers are deformed; raised patches may appear on them and the color may be mottled, with a distinct tendency

towards the production of yellowish spots. The cause of the disease has not been worked out and remedies can therefore not be prescribed.

Cabbage

Black Rot — Black rot can be recognized first, at the tips or margins of the leaves. The leaves wither and commence to rot. The most characteristic symptom is perhaps the blackening of the veins. Affected leaves very frequently fall, leaving nothing but the naked stalk. The disease may live over in the soil, on the seed, or in manure which comes from animals which have been fed diseased cabbage. Control measures, therefore, consist in practicing clean culture and proper rotation of crops, the avoidance of infected manure on cabbage soil, and seed treatment. For the treatment of the seed, corrosive sublimate one part, hydrochloric acid two parts, water one thousand parts is used. The seed should be soaked for fifteen minutes. Formaldehyde, used at the rate of one pint to thirty gallons of water may also be used. The disease attacks not only cabbage, but also kale, rape, kohlrabi, Brussels sprouts, collards, turnips, rutabaga, radish, wild black mustard and charlock. This fact should be taken into account in planning a rotation and in practicing clean culture.

Club Root — Club root can be recognized by means of the large tumor-like swellings which form on the roots of the cabbage. These may occur in such number and with such severity as to very seriously decrease the vitality of the plants. The same precautions in clean culture and rotation methods which were mentioned under black rot should be practiced in dealing with the club root. The use of seventy-five bushels of air-slaked lime per acre on cabbage land has sometimes proved effective. The lime should be applied sometime before planting and should be worked well into the soil. Club root attacks nearly all of the same plants which are attacked by black rot. None of these susceptible crops should therefore be used in rotation.

Yellows — The disease (see Fig. 20), as the name indicates, first appears as a very distinct yellowing of the plants. It may be serious enough to destroy a very large percentage of the crop. Control measures up to the present time have been directed very largely towards the possibility of producing resistant varieties. A considerable degree of success has been attained, and it is possible that resistant varieties will soon be developed and made commercially available.

Pea

Leaf Spots (Blight) — There are at least two leaf spots of the pea which are sometimes of economic importance. The spots may be found on the pods as well as on the leaves, and the loss, therefore, results not only in the decreased vigor of the plants but also in the unsightliness of the pods. When the pods are affected seeds also very frequently become affected. When such diseased seeds are used for planting, a great many of them fail to germinate. Even if they do germinate they very frequently serve as a



Fig. 20.—Cabbage Yellows. The lower leaves have fallen, beginning with the lowest. Only a small, worthless head remains.

Courtesy of the United States' Department of Agriculture

starting point for the disease. The methods of control consist in selecting seed from fields which have not shown the disease, or in selecting seed from clean pods, in clean culture methods, and in a careful rotation of crops.

Powdery Mildew—The powdery mildew appears on leaves and pods as a grayish powder. It is sometimes extremely serious. The same precautions as were mentioned under the leaf spots should be observed. In some cases a very thorough spraying would probably be beneficial.

SOFT ROT OF VEGETABLES

A great many vegetables may rot either in the field or in storage. The rot is very frequently soft and foul smelling; it may be extremely destructive. In general, it is more severe when vegetables are grown year after year on the same land. The bacteria causing the rot gain entrance very largely through wounds. If the conditions are favorable for their growth, they may reproduce with amazing rapidity, and the rot may spread very rapidly through the storage bins. The best methods of control are:

1. A careful rotation of crops which avoids the planting of vegetable crops on the same land too often.
2. Care to avoid bruising of the vegetables at digging time.
3. Drying the surfaces of the vegetables before they are put into storage.
4. The maintenance of proper storage conditions, including proper ventilation, and the maintenance of a temperature which is as near the freezing point as possible without actually freezing the vegetables.

GENERAL SUMMARY OF METHODS OF CONTROL OF PLANT DISEASES

Cereal Diseases—The prevention of cereal diseases depends: first, upon a careful selection and grading of seed grain; second, upon a seed disinfection with formaldehyde or with the modified hot water treatment; and third, upon a rotation of crops which provides for the growing of other crops besides cereals on the same land.

Orchard Diseases—Orchard diseases can be controlled very largely by means of proper pruning methods and thorough spraying. In general, the trees should be kept in good condition, by pruning and by care in protecting wounds and bruises. Spraying should then be given.

Diseases of Garden and Truck Crops—In the main the serious diseases of garden and truck crops, including potatoes, depend on the proper rotation of crops, together with the selection of healthy seed, and seed disinfection where necessary. Spraying is often resorted to where foliage or fruit diseases are severe.

These methods are of general application only. A knowledge of the life history of the particular disease in question is often essential. A person should therefore, never take anything for granted, but if in doubt should always write for advice to the nearest experiment station. In most cases the letter should be accompanied by liberal samples of the diseased material in question.

BOOK X

FARM MECHANICS

Part I—The Farm Gas Engine

Part II—The Repair of Farm Equipment

Part III—Rope and Its Use on the Farm

Part IV—Preservation and Treatment of Fence Posts

Part V—Household Labor-saving Devices

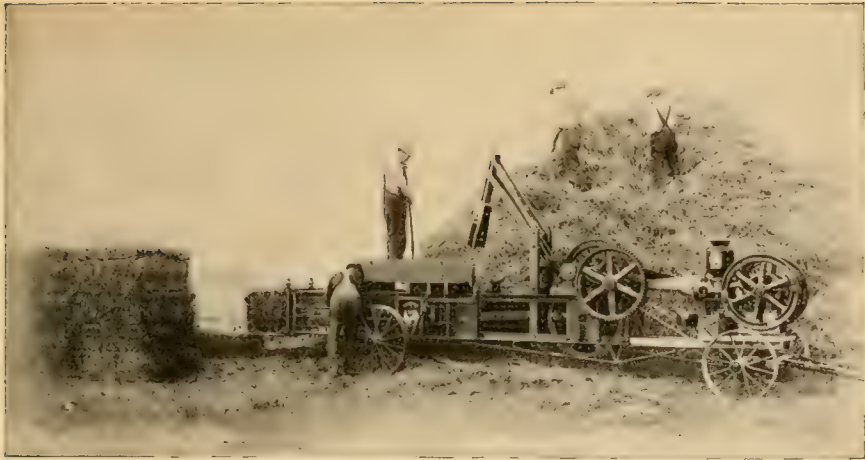

Baling Hay with a Gas Engine.

FARM MECHANICS

PART I—THE FARM GAS ENGINE

CHAPTER I

Its Management and Application for Farm Power Purposes

I. INTRODUCTION—POWER ON THE FARM—POWER MACHINERY INCREASES MAN'S PRODUCTION CAPACITY—FARMER USES MOST GAS ENGINE HORSEPOWER. II. USES FOR GAS ENGINE—HOW IT WAS FIRST USED—IN THE DAIRY—THE FARMWIFE'S HELPER—USING A LINE SHAFT—PORTABLE POWER PLANT. III. FARM MACHINES THAT A GAS ENGINE WILL RUN.

INTRODUCTION

Power on the farm is a subject of intense interest to every farmer. We are realizing now more than ever before, that to farm more intensively and, at the same time, to lower the cost of producing crops, we must use more power. Horse and man power are very much limited when it comes to practising the more intensive methods of agriculture. This is the reason why thousands of farmers are yearly using stationary, portable and traction engines more extensively.

Power on the Farm—Mechanical power will do for agriculture what it has done for manufacturing and transportation. While it will never be used to such an extent as to replace horse and man power entirely, it will be employed for the heavier and more laborious farm tasks where considerable power is required. The need for more power on the farm is keenly felt by almost all farmers, and this fact accounts for the rapidly increasing use of the farm gas engine.

Power Machinery Increases Man's Production Capacity—The use of power machinery on the farm enables each worker to produce five times as much as it was possible for him to do a generation ago. For example, a six-horsepower gas engine belted to a corn sheller will shell a thousand bushels of corn in a day. It will not require more than two men to operate the outfit. If these two men were to do the same work, using a hand-power sheller, it would take several days to shell a thousand bushels of corn.

Practically every farmer can make profitable use of a gas engine; many farms need more than one engine. Moreover, it is a fact that farmers in every section of the country are rapidly getting the power-farming idea. For farm power the gas engine is truly revolutionary. It necessitates to a certain extent the reorganization of the farm on a more systematic and economic basis.

The thing that appeals to every farmer, who has used an engine for his farm work, is that it saves time, men and money; it gets results. Not only that, but it makes farm work easier for the farmer and his family; and it does it more cheaply and better than other power.

Farmer Uses Most Gas Engine Horsepower—It is between fifteen and twenty years ago that the first gas engine was put into practical use for doing farm work. Now, even though a comparatively small percentage of farmers own gas engines, the American farmer uses more gas engine horsepower than all the other industries of the world combined. One authority predicts the profitable use of thirty to forty million horsepower on the farms of this country in stationary and portable engines.

USES FOR THE GAS ENGINE.

The important thing that a farmer wants to know before he buys a gas engine is what it can do to make farm work easier and more profitable. There are many kinds of work for which an engine is particularly well adapted, and for which it can be used to very good advantage. Farmers who own them are finding that their engines are their right-hand men. After using them and demonstrating their labor-saving qualities, they find that they could not get along without them.

The scarcity and high price of competent farm labor have been largely responsible for the use of gas engines on the farm. The uncertainty of labor has made the farmer look about for more reliable help. It is a scientific fact that the most expensive form of energy is muscular, particularly that of man. Adapting this to the farm, the power exerted by men in doing different kinds of work costs considerably more than that developed by a gas engine.

Lessens Labor—The gas engine not only reduces the required amount of hired labor, but it also does away with an enormous amount of manual labor ordinarily required of the farmer himself or the other

members of his family. Many of the small farm machines that were formerly operated by hand are now belted to an engine and the work not only done more quickly but more cheaply and more efficiently. As a factor in relieving the drudgery of farm work the engine has no equal.

As stated before there are many farm tasks which the engine can be made to perform profitably, that is, more profitably than is possible by the use of hand labor. This is just what everyone is interested in. Most farmers do not consider it a profitable investment to purchase an engine for merely doing one kind of work. A single-purpose engine cannot be called a good paying proposition; it must be used for a variety of work in order to get the greatest amount of profit out of its use.

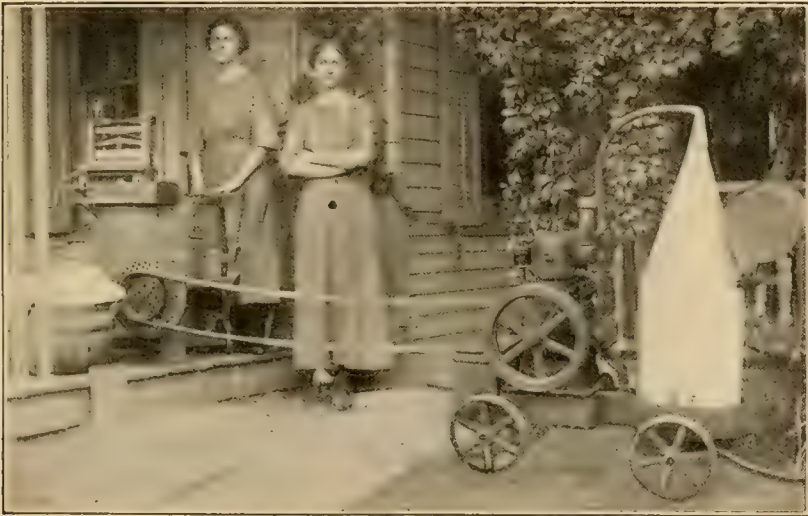

Fig. 1.—The housewife's handy helper belted to a washing machine.

How It Was First Used—The engine has found its way to many a farm because it was needed primarily for pumping water for household and live-stock purposes. The first gas engines sold to farmers were used almost entirely for this kind of work. Many farmers right now, who have purchased their engines for pumping, are using them for that and nothing else. They are letting a good opportunity go to waste, for the engine might be doing other kinds of work just as well as pumping. All that is needed is a little extra equipment to make this possible.

Uses for the Gas Engine in the Dairy—The gas engine is a very valuable addition to the dairy. It is now used very extensively by farmers and dairymen for operating cream separators, churns, butter workers, and to some extent for milking machines. It is particularly

well adapted to running the cream separator, for with the use of a governor pulley it will maintain a uniform speed, which is so essential for best results in separating cream. Many dollars are lost by farmers because of improper speeding of their cream separators. When a separator is operated by hand power it is impossible to maintain a uniform rate of speed. The use of the gas engine eliminates this difficulty and adds to the income from the cows.

Saves Labor in the Household—The gas engine has been the means of solving the hired girl problem in many farm homes. It has proved to be the women-folks' best helper. The back-breaking drudgery of Monday washday has been materially lessened on a great many farms by belting the engine to the washing machine and wringer. The farmer's wife has long been in need of an efficient means of relieving herself of a host of household duties that could be done equally well and better, for that matter, by some other method. The gas engine seems to "fill the bill" as effectively and as satisfactorily as anything.

Using a Line Shaft—The idea of using a line shaft, to which a number of machines can be belted and driven by the engine, is a thing that many farmers are interested in and which is rapidly coming into use. The facility with which the different machines can be belted to this shaft, without moving the engine or any of the machines from one place to another, is a big advantage in saving time, and is also much more convenient.

Many small engines that were originally purchased for pumping water, are belted to a line shaft and made to run the pump, washing machine, cream separator, churn, grindstone, and other small machines that do not require more than one and one-half to three horsepower. When it is desired to operate any machine, put on a belt which connects the machine to the line shaft, and start the engine. If too much power is not required at any time, or if the engine is large enough to handle them, two or three machines may be operated at the same time, thus cutting down the expense of each.

(The subject of the farm power house and how to equip it with line shaft, hangers, pulleys, etc., will be treated more in detail in a succeeding chapter.)

In the matter of electric lighting, the farmer is now able to enjoy the advantages of the city man, for the gas engine has made it possible on the farm. Without the gas engine only a very small percentage of farmers would be able to secure electricity for lighting their homes. Owners of large farms or estates have found it profitable to install fairly large power plants for generating electric current to be used by electric motors for driving different farm machines. A plant of this kind is not practical, however, except where the electricity is to be used on a large scale.

A Portable Power Plant—Not all the farm work required of a gas

engine can be done in a farm power house. As a portable power plant to be moved about from one place to another to drive different machines, the engine is a very useful addition to the farm machinery equipment. The various operations, which in most cases make it necessary to move the engine from one place to another, are running the grain dump and elevator, cutting silage, sawing wood, corn husking and shredding, threshing, baling hay and straw, unloading hay, mixing concrete, pulling stumps, and other jobs. For this purpose it is much better to have the engine mounted on trucks, to make it easier to move about.

During the last few years the engine has been used to an increasing extent for harvesting the grain crop. As a tractor it is used to haul a string of binders of four to eight or more in number, and as a stationary engine it is mounted on the frame of the binder at the rear, where it

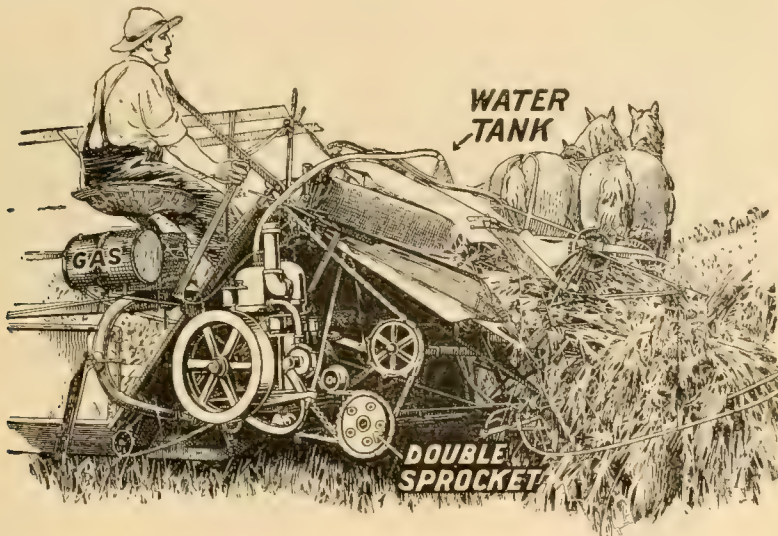

Fig. 2.—A gas engine mounted on a binder frame and used to operate the elevating and binding mechanism.

is used to drive the elevating and binding mechanism. In this way it relieves the horses of a great deal of draft; a fewer number are required; and, the work being made easier, the harvesting progresses at a more rapid rate. All that is required of the horses is sufficient power to haul the binder over the ground; the machinery part is all driven by the engine.

Many ingenious farmers, by means of a stationary engine and a set of transmission gears, have devised auto-mowers that have proved fairly satisfactory. Mechanical power for operating mowing machines is in great demand to shorten the haying season and decrease the time ordinarily required for cutting.

Besides the tasks mentioned in the preceding paragraphs for

which the gas engine can be used, there are many others which can be done advantageously with engine power. The following is a list of some of the farm machines that an engine will operate.

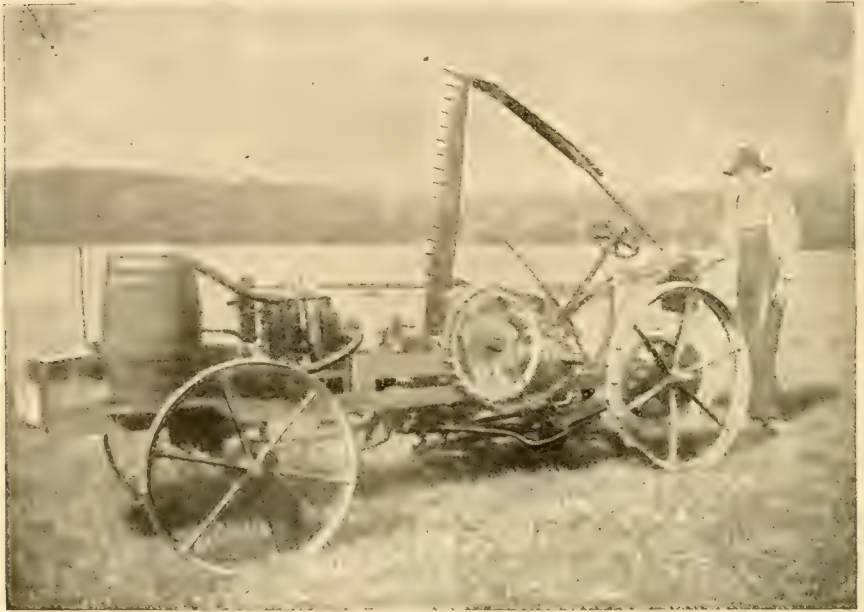

Fig. 3.—An auto-mower, operated by a 13-year-old boy. It works faster than horses.

Farm Machines that a Gas Engine Will Run

- | | |
|--------------------------------|----------------------|
| air compressors | grindstones |
| blowers | hay and grain hoists |
| bone cutters | hay presses |
| bottle washers | honey extractors |
| bread mixers | ice cream freezers |
| butter workers | lathes |
| cement mixers | lime pulverizers |
| cement tile and block machines | meat grinders |
| churns | milking machines |
| cider mills | motor boats |
| clippers | mowing machines |
| corn binders | potato diggers |
| corn huskers | potato sorters |
| corn pickers | pumps |
| corn shellers | refrigerators |
| corn shredders | sewing machines |
| cotton gins | silage cutters |
| cream separators | spraying outfits |

dish washers
drill presses
electric light plants
elevators
fanning mills
feed cutters
feed mills
grain binders
grain dumps
grain graders

stone crushers
stump pullers
threshing machines
tool grinders
vacuum cleaners
ventilating fans
washing machines
well drills
wood saws
wood splitters

CHAPTER II

WHAT IS A GAS ENGINE?

- I. WHY CALLED INTERNAL-COMBUSTION ENGINE—TWO MISCONCEPTIONS OF TERM "GAS ENGINE." II. CHEMICAL PROCESS OF BURNING—NEED OF ELECTRIC SPARK. III. PARTS OF ENGINE AND THEIR RELATION TO ITS OPERATION—HOW ENERGY IS STORED UP IN FLYWHEEL—ACCESSORIES TO THE ENGINE PROPER.

The internal-combustion engine, or gas engine, as it is more commonly called, is one in which gaseous or liquid fuels, such as natural gas, producer gas, alcohol, gasoline, naphtha, kerosene, distillate, or crude petroleum, are burned in the engine cylinder in the form of a gas, and the heat units contained in the fuel are converted into mechanical power. It is called an internal-combustion engine because the burning of the fuel takes place within the cylinder of the engine, instead of in a separate compartment, as is the case with the steam engine, which is known as an external-combustion engine, because the fuel is burned in the furnace under the boiler and not in the engine proper.

There are two common misconceptions regarding the term "gas engine." Many are of the opinion that it refers to an engine that uses either natural gas or producer gas for fuel; while others have the idea that it is simply an abbreviated form of the term "gasoline engine." As a matter of fact both of these are wrong.

Principles of Burning — Getting down to the technical principles of combustion or burning, it must be understood that any fuel, whether a liquid or a solid, must first be converted into the form of a gas or vapor before it can be burned. This is why it is called a "gas engine" — because the working substance is in reality a gas.

It must be remembered that all fuels are composed almost entirely of carbon and hydrogen. When we observe a block of wood or a lump of coal burning, to all appearances the solid matter seems to be burning, but this is not the case. Before combustion can take place the solid must first be heated to such a temperature that a gas will be formed, and it is this gas that burns. What really takes place is that, when the solid is heated sufficiently, the carbon and hydrogen are set free or given off in the form of a gas. As this gas comes in contact with the surrounding air, the oxygen in the air unites with the carbon to form carbon dioxide and with the hydrogen to form water. This is the whole chemical process of combustion in a nutshell.

Electric Spark Necessary in the Gas Engine — In the gas engine, however, an electric spark is necessary to start combustion. The reason

for this is that the fuel, as it is taken into the cylinder, is not in the form of what is technically known as a "perfect gas." More heat is required to raise the temperature of this vapor to the point where the carbon and hydrogen in the fuel will be liberated and unite with the oxygen. This is accomplished by the electric spark which ignites that portion of the charge immediately surrounding it. The flame then spreads and ignites the remainder of the charge.

GAS ENGINE PARTS AND THEIR DUTIES

It is essential to understand thoroughly the principles of gas engine operation before one can expect to use it most successfully, but, before this can be done, it is first necessary to know the different parts and accessories of the engine and their relation to its operation. Each separate part has a duty to perform. Successful operation of the machine depends upon each part working in harmony with the rest.

Let us first begin with the *cylinder*; it is there that combustion takes place, converting the heat energy of the fuel into mechanical power. The cylinder can be called the business end of the engine. The *piston*, which is free to move, is forced out to the farther end of the cylinder by the impulse caused by the exploding fuel. Its duty is to carry the force of the explosion to the *connecting rod*, which in turn converts the straight-line motion of the piston to the rotary or whirling motion of the *crank*. Thus the work developed in the cylinder by the expansive effect of the burning fuel is transformed into mechanical power at the crank shaft, where it is available for power purposes.

Storing Up and Delivering Energy— It is the duty of the *flywheel* to store up the energy received by the crank shaft and deliver it in a uniform manner. With an engine in operation the force on the crank tending to make it turn is not continuous. In the four-cycle engine the piston receives an impulse only at every other revolution of the crank; in the two-cycle engine it receives an impulse at every revolution, but during only a little over a quarter of the complete turn. The flywheel stores up the energy developed, and with the help of the *governor* causes the engine to run at a uniform speed. Without the flywheel or governor the speed would be extremely variable and jerky.

In building gas engines it is necessary to have a certain amount of clearance between the piston and cylinder. The duty of the *piston rings* is to prevent the loss of compression by making a more perfect fit between the piston and cylinder walls. They prevent the escape of the incoming charge or burning gases around the piston, and also compensate for any wear of the cylinder and piston.

Intake, Ignition and Exhaust of Fuel— The duty of the *valves* and *valve mechanisms* is to provide for the entrance of the fuel mixture into the cylinder at the proper time and to allow the burned gases to escape into

the open air after their work is done. The *inlet* valve opens to let the charge enter the cylinder on the suction stroke, and the *exhaust* valve opens to let the exhaust gases escape on the scavenging or exhaust stroke. The *carburetor* or mixing device supplies the fuel to the engine and proportions the mixture of air and fuel to suit the load conditions of the engine. The *ignition system*, consisting of batteries, wires, spark plug or ignitor, magneto, etc., furnishes the electric spark, which ignites or "fires" the fuel charge in the cylinder at the proper time.

Cooling and Lubricating — The function of the *cooling system* is to dissipate the heat of combustion that is not converted into useful work or which is not carried off by the exhaust; it keeps down the temperature of the cylinder to a point where the proper working of the engine is not interfered with. The *lubricating system* supplies the working parts of the engine with lubricant to eliminate as much as possible the loss of power due to friction.

It is the duty of the *governor* to control the speed of the engine by automatically adjusting the amount of fuel to suit the power needs of the engine.

CHAPTER III

PRINCIPLES OF GAS ENGINE OPERATION

DIFFERENCE BETWEEN FOUR-CYCLE AND TWO-CYCLE ENGINES. I. HOW THE FOUR-CYCLE ENGINE OPERATES. II. SUCTION, COMPRESSION, EXPANSION, AND EXHAUST EVENTS. III. HOW THE TWO-CYCLE ENGINE OPERATES—TWO-PORT ENGINE—THREE-PORT ENGINE. IV. DIFFERENCE BETWEEN TWO-CYCLE AND FOUR-CYCLE ENGINES.

There are two distinct classes of farm gas engines, four-cycle and two-cycle; these are also called four-stroke and two-stroke engines. The terms "four-cycle" and "two-cycle" originate from the number of strokes that the piston makes in order to complete one cycle or one set of operations. Two revolutions of the crank are necessary for a complete cycle in the four-cycle engine, and one revolution completes a cycle in the two-cycle engine.

Two-cycle engines have not been used to as great an extent for farm purposes as have the four-cycle engines. It may be said that both have their particular advantages. Since the four-cycle engine is used much more extensively, its operation will be discussed first.

HOW THE FOUR-CYCLE ENGINE OPERATES.

The accompanying drawings (Figs. 1, 2, 3, and 4) illustrate the operation of the four-cycle engine; they show the position of the valves and pistons for the different events or positions of the cycle. These events are: (1) suction, (2) compression, (3) expansion, (4) exhaust.

Suction Stroke — At the beginning of the *suction* stroke (Fig. 1), the crank is shown in the inner center or head-end, dead center position, and the piston is at the end of its travel nearest the cylinder head. At this point the intake valve is just beginning to open, and as is the case in most engines, the exhaust valve is nearly closed. (Sometimes the exhaust valve is closed on center.) As the crank continues to rotate, the piston moves out toward the other end of the cylinder, which creates a suction causing the charge of fuel and air to flow into the cylinder through the intake port.

In most farm gas engines, the intake valve is opened simply by the suction caused by the motion of the piston; in a few makes it is operated by mechanical means, which is in some respects a decided advantage. When the piston has reached the end of the suction stroke, the intake of the mixture will have been completed, and the intake valve is then closed.

Compression Event — When the end of the suction stroke is reached,

the crank is at the outer center or crank-end, dead center position. At this period of the cycle both the intake and exhaust valves are closed, and the piston is ready to start back on what is called the *compression stroke*. As the piston moves back toward the head of the cylinder, the charge taken in

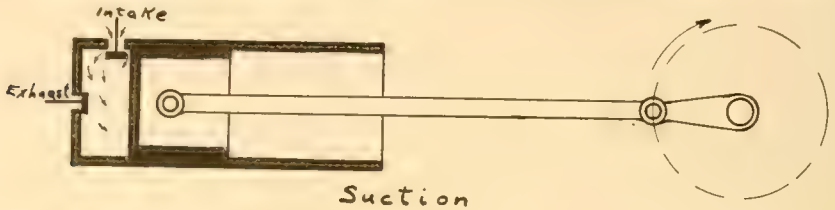

Fig. 1.

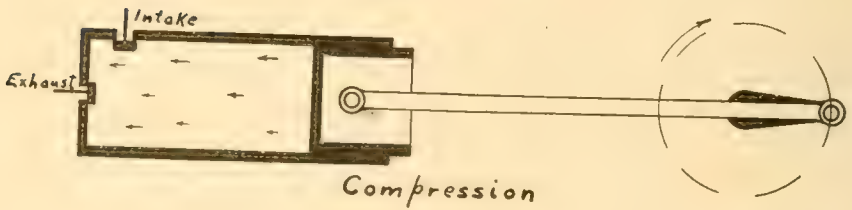

Fig. 2.

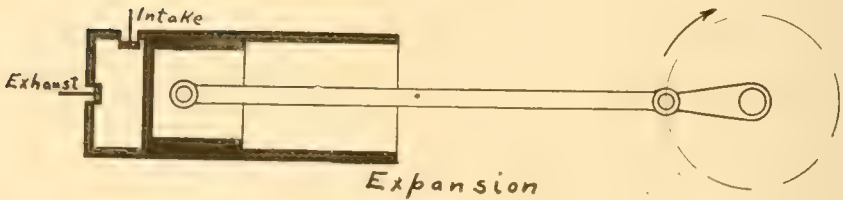

Fig. 3.

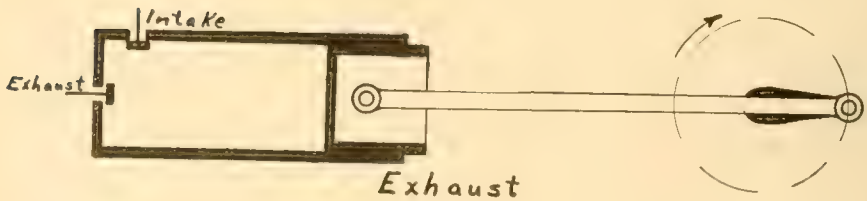

Fig. 4.

on the previous stroke is gradually compressed until it occupies only a portion at the end of the cylinder known as the clearance or combustion space. A considerable pressure is reached during compression, which varies from fifty to one hundred and fifty pounds per square inch in different engines.

Shortly after the piston reaches the end of the compression stroke,

the fuel charge is ignited or "fired" by means of an electric spark. The reason for this occurring before the end of the stroke is to allow the charge to become as completely ignited as possible before the beginning of the following stroke, in order to use the heat energy in the fuel to the greatest advantage.

Expansion Stroke — At the beginning of the *expansion* or *working stroke* the piston is at the inner center position and the compressed charge has been ignited. As combustion of the fuel takes place, the temperature in the cylinder arises very rapidly causing the gases to expand and create an enormous pressure behind the piston. It is the expansion of the burning gases that does the work on the piston, and thereby forcing it out to the further end of the cylinder.

The working stroke or *power* stroke, as it is sometimes called, is the only one during the four events of a cycle, in a four-cycle engine, in which an impulse is given to the piston thereby developing power. The force exerted on the piston during this stroke must not only cause the engine to maintain a uniform speed during the other strokes, but it must also furnish an excess power to operate other machines without any appreciable variation in speed.

During the working stroke the intake valve remains closed, but the exhaust valve in most engines begins to open when the piston has covered about three-quarters of its stroke. The object of opening the exhaust valve as early as this is to allow the exhaust gases to be driven from the cylinder as quickly and as completely as possible.

Exhaust Stroke — The last event in the cycle is the *exhaust* stroke. During this stroke the piston forces the burned gases out of the cylinder. As pointed out in the preceding paragraph, the exhaust valve starts to open before the end of the working stroke and remains open even until the crank has passed the inner center position, or until the beginning of the suction stroke. The intake valve begins to open before the exhaust valve is entirely closed. The closing of the exhaust valve is delayed as long as possible to allow more complete scavenging of the cylinder. As soon as the piston has reached the end of the exhaust stroke, it is ready to begin another cycle.

Briefly the four events necessary to complete a cycle in a four-cycle engine are as follows: (1) The suction stroke, in which a charge of air and fuel is drawn into the cylinder; (2) the compression stroke, in which the mixture is compressed into the clearance space; (3) the working stroke, in which the burning gases expand converting heat energy into mechanical power; and (4) the exhaust stroke, in which the burning gases are driven out of the cylinder to make way for the new charge—and a new cycle.

HOW THE TWO-CYCLE ENGINE OPERATES

The two-cycle engine is essentially different from the four-cycle type in that only two strokes of the piston (forward and back) are necessary to

complete a cycle instead of four strokes. However, the four events of the cycle occur just the same as they do in the four-cycle engine. The combination of events in the two-cycle engine is as follows: The suction and compression events occur on the "in" stroke of the piston. (Referring to the accompanying drawings, Figs. 5 and 6, it would be the "up" stroke of the piston.) The expansion and exhaust events occur during the "out" stroke of the piston.

The construction of the two-cycle engine is much simpler than the four-cycle type as there are fewer working parts. There are no valves, corresponding to the intake and exhaust in the four-cycle engine. The events of the cycle take place simply by means of the piston covering and uncovering the ports or openings in the cylinder as it travels back and forth.

Operation of Two-Port Engine — There are two types of two-cycle

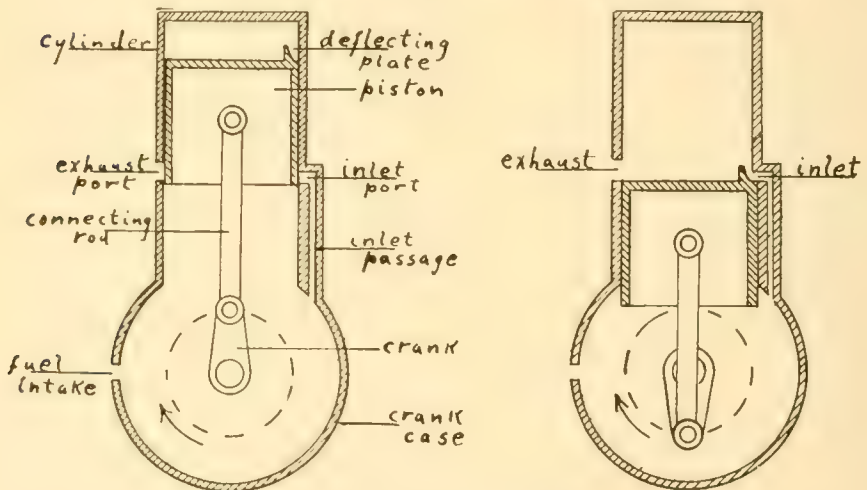

Fig. 5.—Two-port, two-cycle engine.

engines: The two-port and the three-port. The operation of both of these is illustrated by the accompanying drawings (Figs. 5 and 6). Starting with the two-port type (Fig. 5) the piston in the first position is shown at the extreme inner position. Assuming that a charge has been compressed into the combustion space and ignited, the expansion of burning gases will force the piston to the other end of the cylinder.

During the working stroke the exhaust of the burned gases must also take place. By referring to the other extreme position of the piston, it will be seen that as the piston nears the end of the working stroke the exhaust port is uncovered. Due to the great expansive effect of the burning gases, when the exhaust port is uncovered, they rush out very rapidly.

Referring to the relative position of the intake and exhaust ports in the drawing (Fig. 5), it will be seen that very soon after the exhaust port begins to open on the out stroke of the piston, the inlet port on the opposite side of

the cylinder is uncovered. This allows the fresh fuel charge in the crank case to flow into the cylinder. The piston on its out stroke compresses the charge drawn into the crank case on the previous stroke. This compression thus forces the charge up through the inlet passage, through the inlet port and into the cylinder.

A baffle plate, or deflecting plate on the face of the piston opposite the inlet opening, prevents the incoming charge from being forced across the face of the piston and leaving the cylinder with the exhaust gases. As shown in Fig. 5, the charge strikes the baffle plate and is directed upward along the right-hand side of the cylinder until it reaches the top.

Intake of Fresh Charge — As the fresh mixture is entering, the exhaust gases are passing out very rapidly. As the incoming charge strikes the top of the cylinder it is then deflected downward and drives the exhaust gases before it. Due to the fact that the incoming charge enters the cylinder at considerable pressure the exhaust gases are forced out very rapidly. In designing two-cycle engines the aim is to have the piston cover the exhaust port on its up stroke just as the fresh charge is about to leave the cylinder through the exhaust port.

Since the new charge is entering the cylinder at the same time that the exhaust gases are leaving, it naturally follows that the two become mixed more or less. It is true that not all the burned gases are driven out from the cylinder at each stroke, but the extent to which they become mixed is not so great as to materially affect the operation of the engine.

What actually takes place in the engine on the "up" or "in" stroke of the piston? Referring to the drawing in which the piston is shown at the beginning of this stroke, or at the outer end of the cylinder, it will be seen that both the inlet and the exhaust are open. As the piston moves up it first completely covers the inlet opening and then the exhaust. It will be observed that, as the piston moves in this direction, a vacuum or suction will be created in the crank case, since in this particular type of two-cycle engine the crank case is so constructed as to be air tight. This suction will cause the fuel intake valve from the carburetor, indicated but not shown in the drawing to open and allow a charge of fuel to be drawn into the crank case. While the suction event of the cycle is taking place, the piston is compressing the charge admitted into the cylinder on the previous stroke.

The fuel intake valve in the crank case remains closed until the end of the *up* stroke is reached which stroke completes the cycle of events.

It can now readily be seen that the events in the operation of the two-cycle engine are the same as those in the four-cycle engine, except that in the former only two strokes are required instead of four. Briefly the operation of the two-cycle engine is as follows:

An impulse is given, or work done, on the *down* stroke of the piston by the expansive heat energy of the burning fuel. The exhaust of the burning gases takes place during the latter part of the stroke, and a fresh charge is admitted into the cylinder during the latter part of the stroke.

On the *up* stroke of the piston, the charge, which was forced into the cylinder during the latter part of the down stroke and which also assisted to complete the exhaust, is compressed into the combustion space, and the suction of the new charge into the crank case takes place.

The preceding explanation of two-cycle gas engine operation is for a two-port, two-cycle engine. There are essentially two kinds of two-cycle engines: the two-port and the three-port types. The operation of each is practically the same, but a short discussion of the three-port engine will show the difference in the operation of the two types.

The Operation of a Three-Port Engine — The main difference is in the location of the fuel intake opening from the carburetor. This can easily

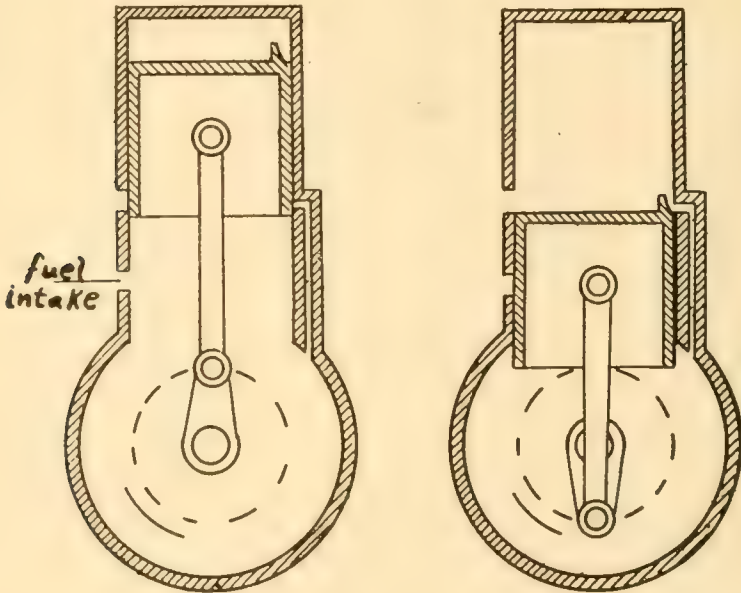

Fig. 6.—Three-port, two-cycle engine.

be seen by comparing the construction shown in Fig. 5 with Fig. 6. In the former the fuel from the intake carburetor is through a valve and an opening of the crank case, while in the latter it is through an opening or a port in the cylinder located near the exhaust port. This is the reason why it is called a three-port engine. This type has no valves whatever, the fuel intake port being covered and uncovered by the piston.

The difference in operation in the two types of engines is that, on the suction-compression stroke, the suction of the charge from the carburetor into the crank case does not begin to take place until the piston has moved a considerable distance on the up stroke. However, when the piston reaches the point where it begins to uncover the fuel intake port from the carburetor, the suction in the crank case is so great that the charge rushes in very rapidly,

and consequently the total amount of time required to complete suction is not so great. The principal advantage of the three-port over the two-port type is that the use of valves is entirely done away with in the former.

There is another type of two-cycle engine with prolonged cylinder and a second piston which compresses the charge. This permits of using an open crank case and removes much danger of crank case explosions.

Differences Between Two-Cycle and Four-Cycle Engines — It is both interesting and instructive to note some of the essential differences between two-cycle and four-cycle engines. The former is so constructed that it has a separate compression chamber, which is merely an airtight crank case, to receive the fuel charge from the carburetor. This is different from the four-cycle engines in that many crank cases in the latter are entirely open. The two-cycle engine has no valves to time. The piston receives a power impulse at every revolution of the crank, while in the four-cycle type a working or power stroke occurs only at every other revolution of the crank.

In the two-cycle engine the cylinder is never entirely free from the exhaust gases; the dead, burnt gases dilute the fresh mixture to a certain extent. But experience has shown that such dilution does not injure the power of the engine until the quantity of burned gases equals about thirty per cent. of the entire fresh charge.

The direction of rotation of the two-cycle engine is reversed simply by shifting the ignitor mechanism. Simplicity of construction is one of its important features, and it is also easy to operate. Thus far, however, its use as a farm engine is limited, the four-cycle engine being the favorite, largely on account of its higher fuel economy.

CHAPTER IV

HOW POWER IS PRODUCED IN THE GAS ENGINE

Part I.—Carburetion

- I. HOW MECHANICAL POWER IS DEVELOPED—EXPANSIVE FORCE OF BURNING FUEL—LOSSES OF HEAT—AMOUNT OF HEAT ENERGY CONVERTED INTO USEFUL WORK. II. CARBURETION—REQUIREMENTS—CARBURETING PROCESS—GETTING THE PROPER MIXTURE. III. LEAN AND RICH MIXTURES—CAUSE—SYMPTOMS—REMEDIES. IV. CARBURETORS VS. MIXING VALVES.

Part II.—Combustion

- I. COMBUSTION DEFINED. II. COMPOSITION OF FUELS. III. PROCESS OF COMBUSTION. IV. WHAT TAKES PLACE IN THE CYLINDER. V. REASON FOR TIME OF IGNITION. VI. RAPIDITY OF COMBUSTION. VII. COOLING AND PRE-IGNITION.

Introduction — The mechanical power developed by a gas engine is obtained from the heat energy made available when the fuel charge is burned in the cylinder. When ignition takes place the mixture of vaporized fuel and air, commonly called the "charge," begins to burn, and the temperature rises very rapidly. The increase in temperature causes a rapid expansion of the gases, thereby exerting an enormous pressure within the cylinder. The piston, being the movable member, is forced out to the other end of the cylinder by the expansive impulse produced by the burning charge. The process consists essentially in transforming the heat energy of the fuel into mechanical power.

The total heat energy or heat units contained in the fuel should not be understood as being transformed into mechanical power at the crank shaft or belt pulley. It is only a small percentage that is converted into mechanical power, and the rest is simply wasted energy. A large percentage of the heat developed is carried away through the cylinders and dissipated by the cooling system; some of it is lost by radiation; and about 25 to 40 per cent of the total heat units contained in the fuel leaves the cylinder with the exhaust gases without doing any useful work. This is what engineers would call a thermal or heat loss. A small percentage of power is lost by the friction of the working parts. Even the best makes of gas engines on the market today convert only about 30 per cent of the heat in the fuel into mechanical power.

CARBURETION

Before power can be developed in the gas engine cylinder, some means must be provided for properly proportioning and mixing the fuel and air.

This is known as "carburetion," and the device used for this purpose is quite generally known as a "carburetor." Mixing devices for preparing the charge for the cylinder are variously known as mixers, mixing valves, generating valves, fuel valves, vaporizers, and carburetors.

Requirements — Considering only the factors of fuel and air, there are three things required for successful carburetion: (1) The fuel must be broken up into fine particles or vaporized, the finer the better. (2) The fuel must be thoroughly mixed with air. (3) The air and the fuel must be properly proportioned.

The Process — Carburetion is a simple process, and the way in which it takes place is shown in the accompanying drawing (Fig. 1). On the

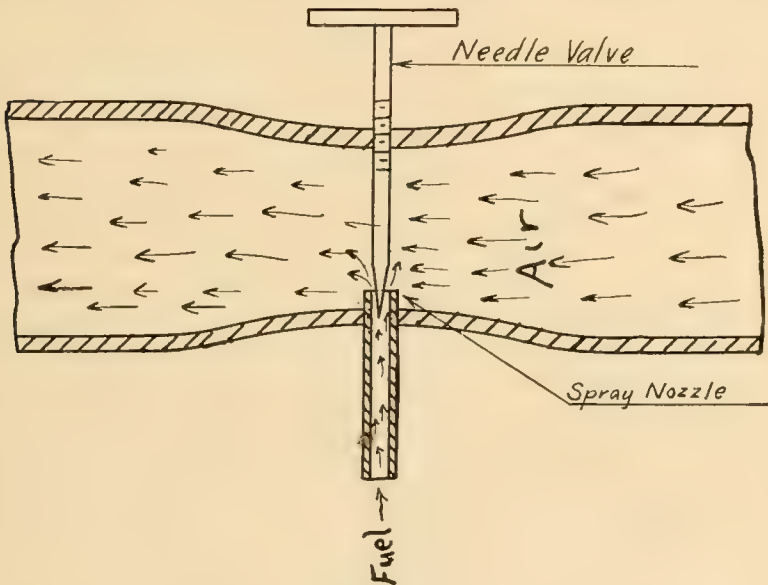

Fig. 1.—A Carbureting device.

suction stroke of the piston the air is drawn in through the air passage by the suction in the cylinder. As it passes the fuel opening or spray nozzle it carries some of the fuel along with it. The proportion of fuel that is mixed with the air in this process is regulated by the needle valve shown in the diagram. As shown, in the most effective types of mixing devices the construction of the air passage is such that it is smaller in diameter at the point where the fuel opening is.

The air passage is contracted at this point in order to increase the velocity of the air past the fuel opening, which results in breaking up the liquid fuel into a finer spray or vapor than would be the case if the opening were larger.

Fuel Not Completely Vaporized — In a gas engine using liquid fuel—gasoline for instance—it should be understood that the process of carburetion does not completely vaporize the fuel before it is taken into the

cylinder. The object in designing any carbureting device, however, is to break up the fuel into as fine a spray as possible, so that when the charge enters the cylinder, complete vaporization will take place very rapidly.

Proper Mixture and How to Get It — In the everyday operation of all gas engines, the proportions of air and fuel in the mixture have to be changed from time to time, for the reason that such conditions as atmospheric moisture, quality of fuel, load variations, changes in outside temperature, etc., vary to such an extent as to make a change in the carburetor adjustment necessary from time to time. As to the matter of varying load conditions, a properly designed carburetor will proportion the amount of air and fuel to meet the changes in load.

The last statement refers only to a throttle-governed engine. In an engine of the hit-and-miss type the governor controls the number of charges taken into the cylinder according to the variation in load conditions.

In order to have the engine operate successfully and give its maximum power, it is necessary to have the fuel mixture properly proportioned. It must not contain too much air and too little fuel, or vice versa. If a charge contains too much air and too little fuel, it is called a lean mixture, and if it contains too much fuel and not enough air, it is called a *rich* mixture.

One of the most common symptoms of a lean mixture is the flames shooting back through the air opening. This is known as "backfiring." Also when a mixture is too lean the engine will not pick up speed to any extent; it lacks power.

Cause of Backfiring — If the proportion of fuel contained in the mixture is too small, the charge will burn slowly instead of instantaneously as is true of a good mixture. It burns so slowly that it is still burning when the intake valve opens on the following suction stroke. In this way it naturally ignites the incoming charge, most of which is still in the intake passage, and the flames shoot back through the air passage.

Remedying a Lean Mixture — In order to correct a lean mixture the needle valve should be adjusted to give more fuel, or the amount of air should be cut down. When a farmer buys an engine, it is accompanied with instructions for adjusting the carburetor to give a properly proportioned mixture. The manner of adjusting the various devices is so different that it would be impossible to give any useful information here as to just what should be done.

Cause and Remedy for a Rich Mixture — Black smoke issuing from the exhaust pipe is a common indication that the mixture is too rich. Also there will be an odor of fuel in the exhaust gases showing that combustion has been incomplete. This waste fuel will frequently ignite in the exhaust passages and will be noticed by a popping sound. Another indication that a mixture is too rich is that the cylinder will heat up quickly. The ignitor points or spark plugs will become covered with a carbon deposit in a short time, which greatly interferes with ignition. There will also be a noticeable decrease in the amount of power developed.

The proper way to correct a mixture that is too rich is to decrease the amount of fuel taken in with the charge or to increase the proportion of air. In a properly proportioned mixture the exhaust is always clear. In using kerosene fuel in a gas engine a blue smoke will be seen coming from the exhaust at times. This may indicate either incomplete combustion or an excess of lubricating oil. It is the black smoke that indicates a too rich mixture.

Carburetors vs. Mixing Valves — There is an opinion which seems to prevail quite generally among farm engine users that the type of carburetor used on automobiles is more satisfactory for stationary gas engines than is the ordinary mixing valve furnished with most engines. The fact is, if the manufacturer had found through careful experiments, which he usually makes, that a carburetor would be enough better for his engine than a mixing valve, he would have used it in the first place. But, in general, the mixing valve will give just as good satisfaction as the higher priced carburetor, and an engine equipped with a real, sure-enough carburetor will naturally cost more.

GAS ENGINE COMBUSTION

According to the dictionary definition, "combustion" means simply a burning. The combustion or burning of the fuel in the gas engine cylinder is nothing more than a simple chemical process. This process cannot take place, however, under ordinary conditions; a very high temperature within the cylinder is necessary to make it successful and complete. Every gas engine user should know something about the process of combustion in order to thoroughly understand the operation of his engine and be successful with it.

Composition of Fuels — All petroleum fuels, such as gasoline, kerosene, etc., are composed of the compounds called hydrocarbons which are made up of the elements of carbon and hydrogen. The proportions of carbon and hydrogen in the different fuels vary, depending upon the specific gravity of the fuel.

Atmospheric air is composed of approximately 23 parts (by weight) of oxygen and 77 parts (by weight) of nitrogen, which exist as a physical mixture.

The carbon and hydrogen, of which the fuel is composed, are in what is known as the chemical combination. In order for combustion to take place it is necessary to break up the hydrocarbons and liberate the hydrogen and carbon elements; intense heat is necessary to do this.

The Combustion Process — Combustion or burning is simply a process by which the free elements of carbon and hydrogen unite with the oxygen of the air. This is the reason why air is taken into the cylinder with the fuel during the process of carburetion.

The breaking down of the hydrocarbons in the cylinder is brought about by heating them to a very high temperature. On being liberated from the

fuel compound, the carbon unites with a portion of the oxygen and forms another compound which is known as "carbon dioxide." The element, hydrogen, combines with another part of the oxygen to form water, which is in the form of steam. Thus we have as a result of combustion the formation of two distinct compounds.

Since **each** pound of air consists of only about 23 per cent oxygen, it is evident that, in order to obtain perfect combustion, a very large amount of air must be supplied as compared to the quantity of fuel used. It has been deduced theoretically that each pound of gasoline will require 203 cubic feet of air. On account of the fact that it is never possible to obtain ideal conditions for the operation of the gas engine, it is necessary to use a somewhat larger quantity of air. Probably from 240 to 260 cubic feet will be required for the most satisfactory combustion of each pound of fuel.

As pointed out in the first of this chapter, the proper proportioning of the fuel and air is almost entirely a matter of following the directions that come with the engine, in which case the engine user should have practically no trouble whatever from this source.

What Takes Place in the Cylinder — In order to more thoroughly understand the process of combustion in the engine, it is necessary to know just what goes on inside of the cylinder. When a certain period in the gas engine cycle is reached, the fuel charge that has been compressed into the combustion space in the cylinder is ignited by the electric spark. Only that portion of the charge immediately surrounding the spark gap is at first set on fire. This raises the temperature in the immediate vicinity sufficiently so that the flame travels outward and in doing so ignites the remaining portions of the charge. The combustion of the charge is more of a burning than it is an explosion; contrary to what many believe the charge does not take fire instantaneously. However, the burning is very rapid, so much so that it is the next thing to an explosion.

Reason for Time of Ignition — The fact that combustion of the charge is not instantaneous explains why in timing the ignition of an engine, provision is made for the electric spark to be produced a trifle before the head-end center position of the piston is reached. By having ignition occur at this particular time, the entire charge has a chance to become ignited, and the expansive force of the burning fuel to be developed while the crank is rotating past the center position. In this way it reaches the best position in the crank circle when it receives the full impulse of the piston. In no gas engine is ignition absolutely instantaneous, but the more rapid the better.

Rapidity of Combustion — The rapidity with which a fuel burns depends upon four things: (1) volume of charge at ignition, (2) temperature before ignition, (3) degree of vaporization and proportion of air, and (4) general character of the fuel. At certain times of the year the fuel charge as it enters the cylinder is quite liable to be cold, in which case combustion will be slow. This would, of course, be apt to make starting more difficult. But after the cylinder has become hot, the fuel will be heated up

as it enters. Heat is also generated in compressing the charge into the combustion space, which too, helps to raise the cylinder temperature. •

Cooling and Pre-Ignition — As the temperature of combustion gets even as high as 2,500 degrees Fahrenheit, it is necessary to provide some sort of a cooling system for dissipating this waste heat and to keep the cylinder temperature below a point where the incoming charge will not be ignited until it is set on fire by the electric spark.

It sometimes happens that the cylinder is so hot that the fresh charge is fired before the spark occurs. This is what is known as “pre-ignition” or “premature ignition.” Pre-ignition may be due to five distinct causes: (1) engine too hot, (2) compression too high, (3) glowing carbon or glowing sharp points on the cylinder walls, (4) uncertain ignition, and (5) pockets of burning gas in the combustion space.

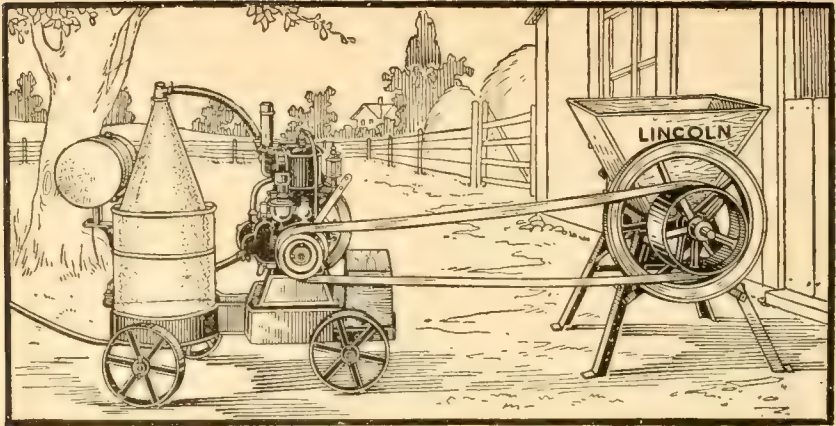

A Portable Engine and Feed Grinder That Saves Frequent Trips to the Grist Mill.

CHAPTER V

FUELS FOR FARM GAS ENGINES

I. REQUIREMENTS OF A GOOD FUEL. II. KINDS OF FUEL—HOW THEY ARE OBTAINED—DIFFERENCES. III. COMPOSITION OF CRUDE OILS. IV. HOW PETROLEUM FUELS ARE PRODUCED—COMMERCIAL GASOLINE—KEROSENE. V. CLASSIFICATION OF PETROLEUM FUELS BY WEIGHT—COMPARATIVE TABLE—BAUME SCALE. VI. CHANGES IN GRAVITIES OF PETROLEUM FUELS. VII. HEATING VALVE—GASOLINE COMPARED TO KEROSENE.

Requirements of a Good Fuel—A gas engine fuel to give the best possible satisfaction should, first of all, mix readily with air to form a combustible vapor. Likewise in burning it should leave little or no carbon deposits; combustion should be clean to make it an ideal fuel. But with the kinds of fuel that are being used with gas engines it is practically impossible to get a fuel that will meet ideal conditions. Absolutely perfect combustion is very difficult to obtain, but by first-class management of the engine it is quite possible to approach very near to it.

Kinds of Fuels—The fuels that are adapted for use in gas engines are: natural gas, illuminating gas, power or producer gas, alcohol, and the petroleum products. The last named include gasoline, naphtha, kerosene, distillate, and crude oil. These are by far the most important fuels at present, and are practically the only ones that farmers are interested in.

The petroleum fuels are obtained from what we know as crude oil or crude petroleum, of which there are two classes or grades in this country. The crude oils produced in the eastern part of the United States, that is, east of the Mississippi river, have what is called a paraffine base. The term "base" refers to the solid portion of the original oil that is left after the gasoline, naphtha, kerosene, distillate and lubricating oils have been distilled

off. After the refining process of the eastern oils is complete, there is left, besides the waste, the product paraffine.

The crude oils in the western and southwestern part of the United States have, in general, an asphalt base. The mid-continent oil fields produce crudes that vary from a semi-asphaltic to an asphaltic base.

Composition of Crudes— The comparative composition of California and Pennsylvania crude oils is shown in the accompanying illustration (Fig. 1). It will be seen that the proportions of the various products are considerably different in these two classes of oils, and also that the proportion of the distilled products available for gas engine fuels is much greater in the Pennsylvania oils. The California oils will produce only about 3 per cent gasoline, while the Pennsylvania oils are capable of producing at least 14 per cent of commercial gasoline.

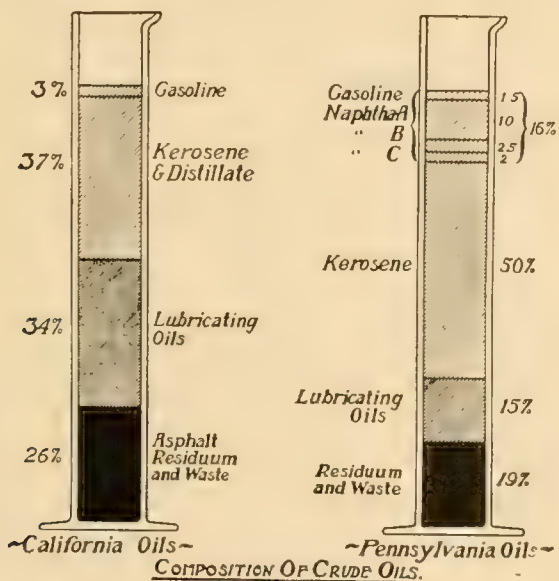

Fig. 1.

Producing Petroleum Fuels— Gas engine petroleum fuels are obtained from the crude oil by a process known as “fractional distillation.” The crude oil after it is pumped from the earth is refined in large vessels by applying heat to the exterior. The temperature of distillation is raised gradually to allow the more volatile portions to distill off. The vapor that is driven off is carried to condensers where it is cooled and reduced to a liquid.

The products resulting from boiling the crude oil to a temperature of 140 degrees Fahrenheit come under the general class of petroleum ether, and are used principally for medicinal and scientific purposes. They vaporize very readily when exposed to the air and are very inflammable. The product that is distilled off between the temperatures of 140 and 200 degrees is known

as gasoline. Naphtha is that which is distilled off between the temperatures of 200 and 400 degrees.

Commercial gasoline, which includes both engine and store gasoline, comprises the various grades of petroleum products known as gasoline, benzine, naphtha B and naphtha A. It consists of all the liquid that is distilled from the crude oil between the temperatures of 140 and 300 degrees Fahrenheit.

Further distillation of crude oil, between 400 and 450 degrees, gives the product kerosene, and from 450 to 500 degrees what is known as "engine distillate" is obtained. Above a temperature of 500 degrees the lubricating oils and solid portions are obtained.

Classification of Petroleum Fuels by Weight — The distillation temperatures do not determine entirely the properties of gas engine fuels. The comparative availability and adaptability of a fuel for use in gas engines is determined by its weight. The accompanying table, showing the correct approximate weight of petroleum products, shows the varying

CORRECT APPROXIMATE WEIGHT OF PETROLEUM PRODUCTS

Product	Degrees Baume	Specific Gravity	Pounds in one gallon
Petroleum ether.....	95	.6222	5.18
	90	.6363	5.30
	85	.6511	5.42
Gasoline.....	85	.6511	5.42
	80	.6666	5.55
	75	.6829	5.69
	70	.7000	5.83
	69	.7035	5.86
	68	.7070	5.89
	67	.7106	5.92
	66	.7142	5.95
	65	.7179	5.98
	64	.7216	6.01
	63	.7253	6.04
	62	.7290	6.07
Naphtha.....	62	.7290	6.07
	61	.7329	6.11
	60	.7368	6.14
	59	.7407	6.17
	58	.7446	6.20
	57	.7486	6.24
	56	.7526	6.27
	55	.7567	6.30
	54	.7608	6.34
	53	.7650	6.37
	52	.7692	6.41
	51	.7734	6.44
	50	.7777	6.48
	49	.7821	6.52
	48	.7865	6.55
	47	.7909	6.59
	46	.7954	6.63
Kerosene.....	46	.7954	6.63
	45	.8000	6.66
	44	.8040	6.70
	43	.8092	6.74
	42	.8139	6.78
Distillate.....	42	.8139	6.78
	41	.8187	6.82
	40	.8235	6.86
	39	.8284	6.90
	38	.8333	6.94
	37	.8383	6.98
	36	.8433	7.03
	35	.8484	7.07
	34	.8536	7.11
	33	.8588	7.15
	32	.8641	7.20
	31	.8695	7.24
	30	.8750	7.29
	29	.8805	7.34
	28	.8860	7.38

weights of the different distillates. Those which distill off at the lower temperatures, are lighter in weight than those which are produced at higher temperatures.

Baume Scale—For use in comparing the weights of the various petroleum distillates, what is known as the Baume scale is now used almost exclusively instead of the specific gravity readings. The reason for this preference is that the Baume scale is much more convenient to use, as the readings are in whole numbers instead of in decimals. The term used is “degrees Baume.” For instance, if a certain gasoline has a specific gravity of .707 it also has a Baume reading of 68 degrees, or 68 degrees Baume. The term “Baume gravity” is also used for “degrees Baume.”

If it should be desired to find either the Baume or specific gravity of any liquid fuel, when one or the other is known, it can be accomplished by either of the two following formulas:

$$\text{Baume gravity} = \frac{140}{\text{specific gravity}} - 130$$

$$\text{Specific gravity} = \frac{140}{\text{Baume gravity} - 130}$$

Changes in Petroleum Fuels—There have been many changes in the petroleum fuel situation during the past two decades, and even during the past decade. The principal difficulty has been for refiners to meet the rapidly increasing demand for gasoline brought about by the coming of the automobile, motor truck, and the farm gas engine. The product, which we know as commercial gasoline, is of a much lower gravity now than it was several years ago. About the year 1900, commercial gasoline would test as high as 76 degrees Baume. Today we get commercial gasoline around 60 degrees Baume.

It should be said that it is now quite common commercial practice to list petroleum fuels as low as 56 degrees Baume as gasoline, and as high as 48 degrees Baume as kerosene. The lower gravity gasoline can be used practically as well in farm gas engines as the better grades. The only difficulty is that the fuel of lower gravity does not vaporize as readily, and consequently starting an engine in cold weather is not quite as easily accomplished. In this case it is always well for the operator to have a little high-test gasoline on hand to start the engine with; in warm weather he should have no trouble from this source.

Heating Value of Petroleum Fuels—As has already been pointed out in a previous chapter, mechanical power is produced by the action of the heat energy, liberated from the fuel, upon the working parts of the engine. There is a standard for measuring this heat energy, and the unit of measurement in this standard is known as the “British thermal unit” (B. t. u.). A British thermal unit is defined as the quantity of heat required to raise the temperature of one pound of pure water one degree on the Fahrenheit scale.

Taking the oils of the United States as a whole, the crudes as well as the distillates range from 18,000 to 22,000 British thermal units per pound. The accompanying table will show that the range in weight per gallon of the various petroleum products varies considerably, yet pound for pound their heating value has been found by careful experimenting to be quite uniform.

It will be understood from this last statement, therefore, that fuels of lower gravity, gallon for gallon, contain more heat units. Kerosene, for instance, contains about eighteen per cent more heat units than does gasoline. Therefore, considered from the theoretical standpoint, it should give more power when used as an engine fuel. But the engines on the market today develop about the same amount of power from a gallon of kerosene that they do from a gallon of gasoline.

CHAPTER VI

POWER OF THE GAS ENGINE

- I. HORSEPOWER DEFINED—FORCE—WORK—POWER. II. BRAKE AND DRAWBAR HORSEPOWER. III. DETERMINING HORSEPOWER—BY FORMULA—BY BRAKE TEST. IV. HOW TO RUN A BRAKE TEST—DESCRIPTION OF BRAKE—METHOD OF TEST—TAKING READINGS—FIGURING THE POWER DEVELOPED. V. WHEN TO USE THE BRAKE TEST. VI. TEST FOR FUEL ECONOMY.

The question of how much power a gas engine is delivering or is capable of delivering is a thing that most engine users want to know at some time or other, and for various reasons. Manufacturers give their machines a certain horsepower rating, and it is usually to the best interests of the owner to know whether his engine will develop its rated horsepower or not. Again, after an engine has been in use for a certain period of time, it is desirable to know if it is still able to develop its rated capacity.

Horsepower—The horsepower is the unit universally used by engineers for measuring power. This unit was first established by James Watt and was a measure of the power that an English work horse could develop. To get a thorough understanding of just what horsepower actually represents, it will first be necessary to understand the terms "force" and "work."

The "foot-pound" is the unit measurement of work. It is the "force" required to move a weight of one pound through a distance of one foot, or to lift a pound weight one foot high.

The terms "work" and "power" must not be confused. The unit of work does not take into account the time element, but the unit of power does. "Power" is commonly defined as the time rate of doing work. For example, if you move a certain object through any distance and do not regard the time, you are simply doing work upon that object. But if you take into account the time required to do that work, then you are said to be developing power. Power includes work.

Therefore, the unit of measurement of power, the horsepower, is doing work at the rate of 33,000 foot-pounds per minute.

Brake and Drawbar Horsepower—The power of an engine available at the crank shaft is referred to as the brake horsepower. It is the power that the engine is capable of delivering when it is belted to any machine. The name is derived from the method that is used to measure this power by means of a Prony brake. The drawbar horsepower refers to the pulling power that is available at the drawbar of a tractor. In most traction engines this is usually about 50 per cent of the brake horsepower; the other 50 per cent is lost in being transmitted from the crank shaft to the drawbar, due to friction of the gears and bearings.

How to Determine Engine Horsepower—There are two common methods of finding the horsepower of a gas engine: by use of a formula, and by actually testing the engine. The first is only an approximate method, but the second is an accurate way of actually determining what an engine is capable of doing.

If one cares to use a formula merely to get approximate results, he can use those given here. For gasoline-burning engines

$$\text{Horsepower} = \frac{d^2ln}{16,400} - 0.5$$

and for kerosene-burning engines the following formula should be used:

$$\text{Horsepower} = \frac{d^2ln}{21,875} - 0.75$$

In these formulas *d* is the diameter of the cylinder, *l* is the length of the stroke, and *n* is the number of revolutions per minute. In their present form they are for single-cylinder engines only. If it is desired to find the horsepower of an engine having more than one cylinder, this can very easily be done by multiplying the results of this formula with the number of cylinders which the engine has.

An Unsatisfactory Method—As stated before only approximate results can be obtained by figuring the horsepower of an engine by means of a formula, and if one desires to get anywhere near accurate information he should not depend upon one. There are so many things in connection with the design and construction of the engine, which affect the amount of power which it will develop, that no one formula can be applied to all engines and be depended upon to give accurate results. One gas engine manufacturer has, by means of a greater refinement in design, been able to double the power of his engine without increasing the size of the cylinder. A formula which takes into account merely the bore, stroke and speed of an engine is not a reliable guide to the power that it is capable of developing.

THE BRAKE TEST FOR GAS ENGINES

To measure the power of a gas engine accurately the best method is to test it by means of a Prony brake. Types of these brakes suitable for testing farm engines are shown in the accompanying illustrations (Figs. 1 and 2). They can be made by anyone who can use tools, and should cost but very little. On most farms the material needed will be found somewhere around the farm.

A simple form of Prony brake for farm use is shown in Fig. 1. It consists of a piece of soft wood timber (A), which is just wide enough to cover the face of the pulley and which is cut on the under side to fit the pulley. If the timber is not available, a two-inch plank will serve the

purpose practically as well. To the under side of this plank should be nailed two blocks of wood beveled off to fit the face of the pulley.

After the piece (A) has been fitted to the belt pulley, a piece of leather or canvas belting (B) is drawn around the under side of the pulley as shown and fastened to (A). One end of B should be fastened to A by means of a couple of iron strips, and the other end be fastened to a bolt which runs up through a hole in A and screws into the thumb nut (C).

In measuring the power of an engine by means of a Prony brake, it must be understood that all the power developed is absorbed by friction. For that reason a large amount of heat is generated between the face of the pulley and the brake. Consequently it is necessary to have an oiler (E) to lubricate the surface of the pulley, so that the brake will not stick to it, while the test is being conducted. If one does not have an oiler, merely a hole in A,

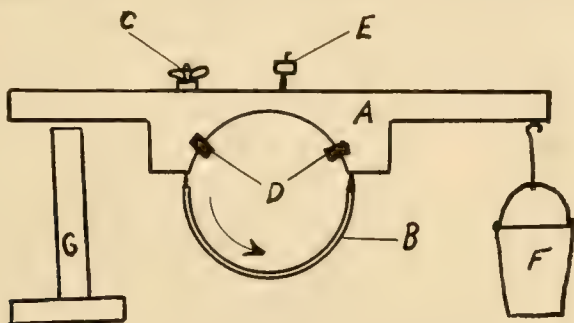

Fig. 1.—A Simple Form of Prony Brake.

into which oil can be dropped occasionally from an oil can, will serve the purpose almost as well.

The pail (F) which is shown hanging to one end of A in Fig. 1, is used to hold the weights for measuring the power. In figuring the horsepower developed by a brake, it is necessary to know the distance, measured horizontally, from the point where the weight (F) is hung to the center of the crank shaft. For greater convenience in calculating the results in any test it would be best in this particular brake to have this distance equal to three feet. This distance is called the "brake arm."

The arrow indicates the direction of rotation of the pulley. The brake should be placed on it so that the weight (F) is toward the head-end of the engine, but in case the pulley revolves in the opposite direction the position of the brake should be reversed. The two strips (D) are fastened to A to prevent the brake from sliding in toward the engine.

HOW TO TEST AN ENGINE

To test an engine with the brake shown in Fig. 1, first place it on the pulley and then start the engine. In starting the engine be sure that the band (B) is loose enough so that it will not stick to the pulley.

If the reader has never conducted a test before, he should proceed in

the following manner: Place some weights in the pail (F), either pieces of iron, stones or sand. Do not use too much weight at the start. Then gradually tighten the brake. When the brake grips the pulley sufficiently, the pail of weights will be lifted from the floor. The object of the stop (G) is to prevent the brake from revolving with the pulley in case it grips the pulley too tight.

Taking Readings—In order to arrive at the horsepower that an engine is developing, it is necessary to take simultaneous readings of the weight that the brake is lifting and the speed of the engine. When the weight is lifted the brake should be balanced as nearly as possible in a horizontal position and with the weight not touching the floor. It can be

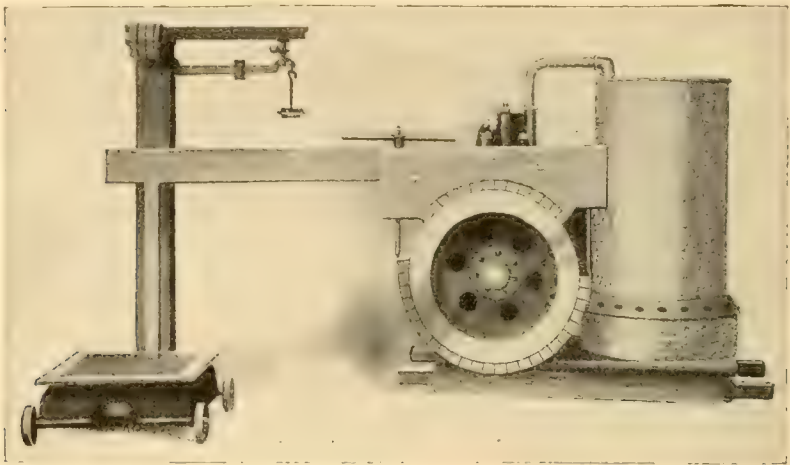

Fig. 2.—Prony brake attached to engine, showing how weight is measured on scales.

kept very nearly in this position by slightly tightening or loosening the thumb nut (C.) The person who is balancing the brake, should be careful not to throw any of the weight of his body on it.

With the brake in a balanced position the speed of the engine should be determined by holding a revolution counter on the end of the crank shaft. Most any hardware store can supply this instrument at a cost of about 75 cents. The brake should be balanced half a minute or so before the reading of speed is taken in order that the speed may have a chance to become adjusted to this particular load. Be sure that the weight does not touch the floor when the speed is observed.

After the speed reading is taken, loosen the brake and take off the pail; then weigh both the pail and the weights in it. This will give you the weight that the engine is lifting.

To Figure the Power—The power of the engine can be figured by the formula.

$$\text{Horsepower} = \frac{W \times l \times n}{5252}$$

In this formula w is the weight of the pail and contents in pounds, l is the length of the brake arm in feet (in this case 3 feet), and n is the speed of the engine in revolutions per minute.

For example, suppose that the weight in the pail was $17\frac{1}{2}$ pounds and that the engine was running at a speed of 400 r.p.m. Then substituting these figures in the above formula we have as the power delivered

$$\text{Horsepower} = \frac{17.5 \times 3 \times 400}{5252} = 4$$

Comparative Data — After one set of readings has been taken, a few more weights should be added and another set of readings taken. By increasing the weights gradually it will be found just how much power the engine is capable of developing, and also the best load at which to operate it.

Practically every user will want to know whether the engine is developing its rated horsepower. That can be determined by using the proper weight in the pail when making the test, and the way to find out just what this weight should be is by means of the above formula. This formula should be rearranged to read as follows:

$$W = \frac{\text{h. p.} \times 5252}{l \times n}$$

Then suppose that the rated horsepower (h.p.) of the engine is six (6), the length of the brake arm is 13 feet, and the speed is 400 r.p.m. Then the total weight of pail and contents that should be used in the test will be

$$W = \frac{6 \times 5252}{3 \times 400} = 26.26 \text{ pounds}$$

or approximately 26 $\frac{1}{4}$ pounds. If the engine pulls this load without difficulty, it is not over-rated.

A Caution — If the engine user finds on testing his engine, that it is capable of delivering more than its rated horsepower capacity, he should not consider it advisable to operate it at its maximum capacity. It is never a good thing to operate a gas engine for any length of time at a load greater than the manufacturer's rating. A great many users make the mistake of overloading their engines, and this is a bad practice. Besides an engine operating above its normal capacity is not as economical of fuel.

When to Use the Brake Test — It is a good plan to test the engine more or less frequently to see if it is developing its rated horsepower, and if not, why not. If it should be found that it is not giving as much power as it should, it is evident that it is underrated or that there is something wrong. A brake test is a very good means of showing up any causes of lack of power, which the user may not have noticed, and in that way it is possible to locate a great many engine troubles.

Almost every gas engine is accompanied with a guarantee to develop a certain rated horsepower. Simply as a means of protection, it would be

advisable for every purchaser to see an engine tested before he pays for it. Furthermore, he should insist that it develop its rated capacity without having to speed it up above its normal speed.

Test for Economy—In connection with the brake test it may be desired in many cases to know what the fuel consumption of the engine is at different loads. The object of this would be to find out at which load the most economical fuel consumption could be obtained, and also to see that the engine under ordinary operating conditions was not using too much fuel.

To do this, means would have to be provided for weighing the fuel as it is used. This can be done by using a separate container or tank, which can be set on a pair of scales and connected to the fuel pipes by flexible rubber hose. With the engine pulling a certain load, the brake should be kept balanced for a period of twenty minutes to half an hour and the fuel consumed during that time should be measured accurately. This is done by weighing the fuel both at the beginning and end of the period.

To figure the fuel consumption, divide the fuel used (in pounds) by the product of the horsepower developed during that particular run by the time reduced to hours. The quotient will give the pounds of fuel used per brake horsepower hour, which is the basis of calculation used by engineers. Of course, it should be understood that when the fuel is measured readings of the brake load and speed of the engine should also be taken at the same time.

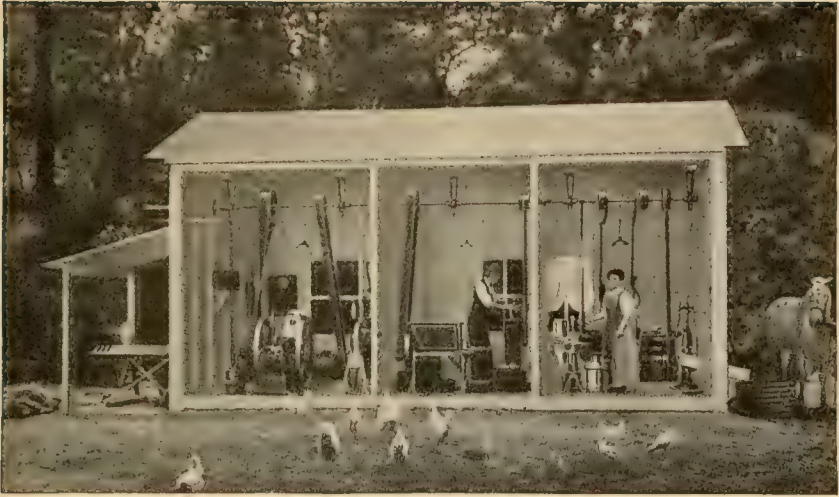

Fig. 1.—The farm power house. The engine must do many things at once and save fuel.

CHAPTER VII

THE FARM POWER HOUSE

- I. MEANS OF GETTING MORE WORK OUT OF THE ENGINE. II. CONVENIENCE OF POWER HOUSE. III. MAKES BETTER CARE OF MACHINERY POSSIBLE. IV. LOCATION OF POWER HOUSE. V. ARRANGEMENT—SEPARATION OF DIFFERENT CLASSES OF WORK. VI. LOCATION OF ENGINE—SETTING FUEL TANKS. VII. POWER HOUSE EQUIPMENT—SHAFTING—PULLEYS—BELTS—HANGERS. VIII. POSITION OF MACHINES WITH RESPECT TO LINE SHAFT AND POWER. IX. PLANNING OF WORK. X. PULLEY SPEEDS AND SIZES—RULES AND FORMULA FOR FINDING.

More Work Out of the Engine—The farm power house probably offers the best possible means for getting the most work out of the gas engine. The engine costs a lot of money in the first place, and, consequently the more work its owner can find for it to do, the better paying proposition it will be.

The average farm engine can be made to do more work than it is now doing, but the owner will never be able to get the most out of it until he provides some sort of arrangement whereby a greater variety of tasks can be done more conveniently. The one best way of accomplishing this is by means of a farm power house, where the greater majority of belt-driven machines can be operated with the engine.

Many farmers are already taking advantage of the opportunity which the power-house idea offers, and they have provided line shafts, pulleys, etc., so that each time it is desired to do a different job with the engine, it is not necessary to reset the engine or the machine, or both. All that

they have to do is to belt the machine to the line shaft and start the engine.

Convenience — In the matter of convenience alone it pays to equip a building, or a portion of a building, so that several machines can be set up and operated by an engine through a line shaft. It is a big advantage because it saves time, labor and other expense. It is convenient in that the engine does not have to be moved from place to place to perform the different tasks.

Probably one reason why the gas engine is not used for a greater variety of farm tasks is due to the inconvenience and loss of time that is required in moving it about to do the different jobs. Many farmers think they can do many jobs by hand quicker and easier than they could by taking the time to set up an engine to do them, and in a great many cases they probably can. But where one has a farm power house equipped with a line shaft, pulleys, belts, etc., less labor and time is required, since the engine and other machines have a fixed position, from which it is not necessary to move them about or reset them every time they are needed.

Machinery Receives Better Care — A great deal of farm machinery goes to waste each year simply because of exposure to the weather. This entails a great loss to the farmer. But if he has a farm power house, in which he can place most of his machinery, the depreciation of these machines is reduced to a minimum. It is a very common sight in traveling from farm to farm to find machinery and implements standing out of doors almost anywhere, and at all times of the year. If there is any piece of machinery that should be properly housed it is the gas engine. Where it is left out in all kinds of weather, it not only depreciates rapidly but is quite liable to give a great deal of trouble.

Another advantage of the farm power house is that it saves a great deal of wear and tear on the engine and other machinery, because they do not need to be moved about from place to place. Any farmer will readily appreciate this, and it should be a good argument in favor of having a well-equipped power house.

Power House Location — The location of the power house should not be settled upon until after a great deal of thought and careful study have been given to it. In order to get the full benefit, it should be properly located with respect to the work that is to be done in it and the convenience of doing the work. As a general thing it should be located near the barn, as that will be the most convenient place for most of the work.

Arrangement of Power House — On many farms it will not be necessary to build a complete new building to be used for the power house. An addition can be made to a building already constructed, or other arrangements can probably be made to utilize a portion or the whole of a building now available. In either case the structure that is

used should be adapted for this purpose in the matter of convenience and accessibility; otherwise it would be cheaper in the end to build a complete new building. Convenience and accessibility should not be sacrificed, as that is what makes for economy every time.

If a variety of work is to be done in the power house, it should be partitioned off into different rooms so as to keep the various kinds of work separated. For instance, it would be necessary to have the dairy machinery kept separate from the feed grinder and fanning mill. Of course, it is possible to have them in rooms by themselves and yet operate them with the same line shaft; the shaft would extend through the partitions of each room from one end of the building to the other. Probably the best possible arrangement would be somewhat as follows:

Separation of Work — In the dairy room should be installed such machines as the cream separator, churn, and butter working machinery. It should also be made large enough to accommodate the washing machine and any other equipment needed by the farmwife, for she will probably do considerable work in looking after the dairy.

In the case of feed-preparing machinery, such as corn shellers, feed cutters and grinders, fanning mills and grain graders, corn huskers and shredders, etc., should be tightly partitioned off from the rest of the power house equipment, as most of these machines raise dust when they are in operation, which would, of course, be most undesirable in the dairy.

If the barn is already equipped with a well-arranged granary and feed room, in many cases it would be possible to locate the power house with respect to the barn so that the machines in the granary could be driven by the engine with an extension of the line shaft, or by using a counter shaft in the granary, which would be belted to the line shaft.

Location of the Power — The location of the engine is the most important of all. Each and every farmer needs a work shop of some description, and if he is building a farm power house he will find it a paying proposition to provide a room for a shop in this building. The proper place for the engine in such a case is in the shop; otherwise it would be best to have it in a room by itself. But tools are probably needed more around an engine than any other piece of farm machinery, so that the logical location for it is in the shop room.

In placing his engine the farmer should not make the mistake of

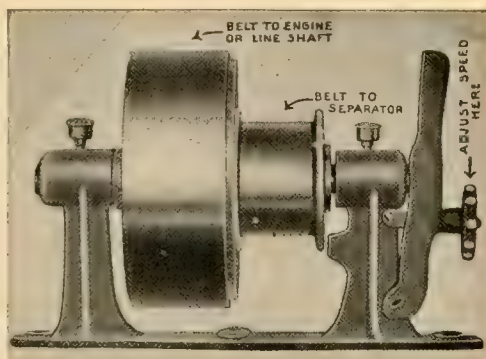

Fig. 2.—A governor pulley should be used in the power house for belting to a cream separator.

setting it off in a corner of the room where it will be hard to get at. It should be accessible from all sides so that it can be cared for, adjusted,

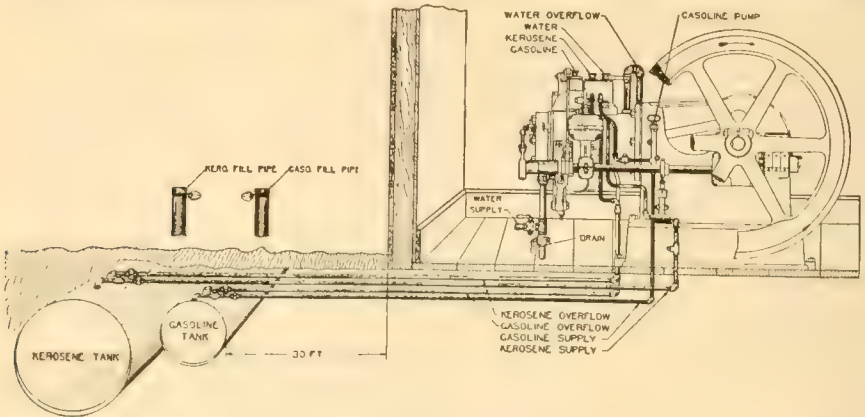

Fig. 3.—Showing location of engine with respect to fuel tanks.

and repaired conveniently. It should have at least a space of three feet all the way around it.

The proper place for the fuel tank is in the ground outside the build-

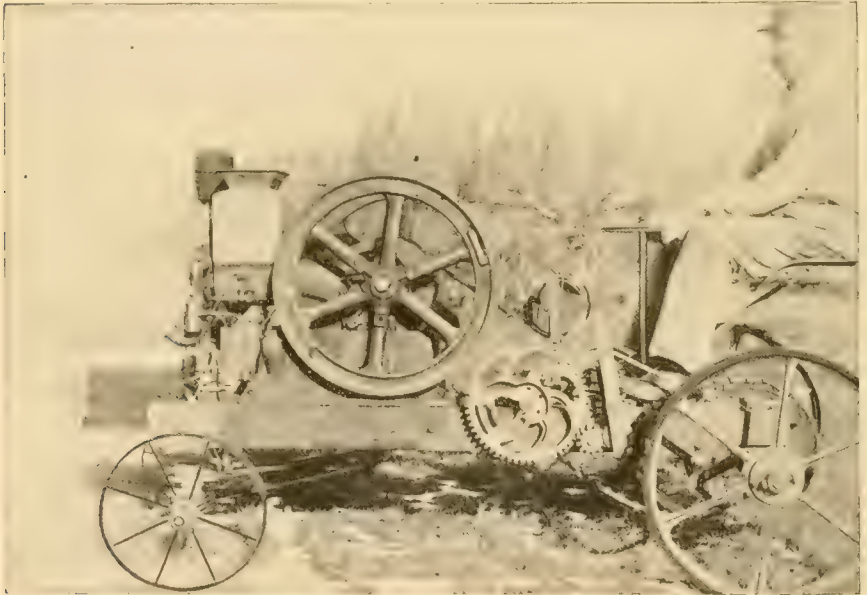

Fig. 4.—A handy portable power plant with a home-made traction rig.

ing where the possible risk from fires will be eliminated, and where the evaporation of fuel during hot weather will be reduced to a minimum.

An important thing in setting the engine is to see that it is placed on a solid foundation. If there is any doubt as to the floor of the build-

ing being solid enough to keep it steady when in operation, a concrete foundation should be built up from the ground and the engine bolted to it. This is undoubtedly the best thing to do in any case, as it is a serious detriment to an engine not to have a foundation that will hold it securely and keep it from jumping around.

POWER HOUSE EQUIPMENT

Aside from the cost of the building, if a new one is put up, the expense of equipping the power house with the necessary shafting, hangers, pulleys, belts, etc., should not be very great. Compared to the saving that it will effect in the more convenient and economical operation of the different machines, the first cost of equipment will be very small. Many times it will be possible for the farmer to pick up some or all of the needed material second-hand, which, if in fair condition, will be practically as good as buying new, and still cost considerably less.

Shafting — Cold-rolled steel shafting should be used. If the engine is a small one, and if it is not to deliver over four horsepower, a shaft about 1 3-16 inches in diameter will be heavy enough. In this case we assume that the shaft is to be run at a speed of 200 revolutions per minute or less. If the line shaft is to deliver more than four horsepower, a larger sized shafting should be used. The accompanying table will show the horsepower that different sized shafts are capable of delivering safely at the range of speeds given. It also shows the amount of horsepower that different widths and thicknesses of belts will transmit on the basis of 100 feet of belt speed per minute.

HORSEPOWER OF SHAFTS FOR GIVEN DIAMETER AND SPEED

Diameter of Shaft Inches	Revolutions Per Minute									
	100	125	150	175	200	225	250	300	350	400
1 3/16	2.4	3.0	3.6	4.2	4.4	5.4	6.0	7.2	8.4	9.6
1 7/16	4.3	5.4	6.5	7.6	8.6	9.8	10.8	13.0	15.2	17.2
1 11/16	6.5	8.0	9.7	11.2	13.0	14.6	16.0	19.4	22.4	26.0
1 15/16	10.0	12.5	15.0	17.5	20.0	22.5	25.0	30.0	35.0	40.0
2 3/16	14.0	17.8	21.0	24.5	28.0	31.5	35.6	42.0	49.0	56.0

HORSEPOWER BELTING WILL TRANSMIT

Width of Belt Inches	H. P. Per 100 Feet Belt-Speed		Width of Belt Inches	H. P. Per 100 Feet Belt-Speed		Width of Belt Inches	H. P. Per 100 Feet Belt-Speed	
	Single Belt	Double Belt		Single Belt	Double Belt		Single Belt	Double Belt
1	.09	.18	9	.82	1.64	20	1.82	3.64
2	.18	.36	10	.91	1.82	22	2.00	4.00
3	.27	.55	11	1.00	2.00	24	2.18	4.36
4	.36	.73	12	1.09	2.18	28	2.55	5.09
5	.45	.91	14	1.27	2.55	32	2.91	5.82
6	.55	1.09	16	1.45	2.91	36	3.27	6.55
7	.64	1.27	18	1.64	3.27	40	3.64	7.27
8	.73	1.46						

Kind of Pulleys to Use — Practically all of the material needed, such as shafting, pulleys, hangers and belting, can be purchased through

any local hardware dealer. If he does not handle it, he can very easily order it. The split wood pulleys are the best to use for farm power purposes, the reason being that they can be taken off and put on the shaft, or changed to new positions without much difficulty. With the solid iron pulleys it is impossible to do this without possibly removing other pulleys, as they have to be slipped off the end of the shaft. Another advantage of the wood over the iron pulleys is that the belts cling to them better, and there is not so great a tendency to slip.

Distance Apart to Place Hangers—A very common mistake in equipping a farm power house is to use too few hangers for the shafting. On the smaller sizes the hangers should not be placed more than six feet apart; an extra hanger will not cost a great deal more and it is much better to have them a little closer together. Where one uses plenty of hangers, there is not the danger that the shaft will be twisted out of shape when it is delivering its maximum amount of power. Where one is using a larger sized shafting, the hangers need not be placed so close together as when using a small shaft, as the tendency to twist it out of shape is not nearly so great.

Position of Machines with Respect to the Line Shaft—The location of the various machines with respect to the line shaft is quite important and should consequently be planned carefully. They should be placed so that when belted to the shaft the belt will be at an angle of 45 degrees with the horizontal, or at a 45-degree angle with the floor. For the best position of the engine the distance from the crank shaft to the line shaft should be from six to eight times the diameter of the larger pulley.

All machines should be set so that their center line will be at right angles to the line shaft, and the pulleys on the machine and the corresponding pulleys on the line shaft should be in line.

Position of the Machines with Respect to the Power—In driving any machine by an engine and through a line shaft, it will be evident to the reader that there is more or less of a twisting strain brought upon the shaft and bearings. Also the greater the distance on the shaft between the point where the power is delivered to it and the point where it is taken from it, the greater will be the twisting effect. Therefore, if possible, without sacrificing convenience and accessibility, those machines requiring the greatest amount of power to operate them should be belted to the line shaft as near the engine as possible. Also wherever it can be arranged, the machines that take the most power should be belted to the shaft as near a hanger as may be, to decrease the bending effect on the shaft as much as possible.

Planning the Work—In a properly equipped farm power house, the engine that is used should be capable of furnishing power sufficient to drive the largest machine. There would probably be several other machines that would require considerable less power. It is much more

economical to operate the engine at as near full load as is possible. For that reason the work should be so arranged, as nearly as it can be, so that two, three, or more of the smaller machines can be run at the same time. In most cases this will not only save labor, but the operating cost of the engine will be spread over that much more work. For instance, a six horsepower engine could be pumping water and charging the storage batteries for the farm lighting plant, while it is running the cream separator or churn, or both. This idea of doing several tasks all at one time is one of the big advantages of the farm power house.

Determining Pulley Speeds and Sizes — In the equipping of a farm power house one of the important problems that will have to be solved before the equipment can be purchased is the size of the pulleys that will be needed on the line shaft to give the proper speed to the various machines. In this connection, it should be said that it is not advisable, for best results, to have the line shaft run at a speed of more than 200 revolutions per minute.

In the first place, the farmer should find out the speed at which each machine should run for best results. If he does not have this information, it can be obtained from the agent who sold him the machine or from the manufacturer. With this information and the sizes of pulleys on all the machines, he can figure the sizes of the corresponding pulleys needed on the line shaft. This can be accomplished by the use of the four following rules:

(1) To find the size of the driving pulley, multiply the size of the driven pulley by its speed and divide the product by the speed of the driving pulley. The quotient will be the size of the driving pulley.

(2) To find the speed of the driving pulley, multiply the size of the driven pulley by its speed and divide the product by the size of the driving pulley. The quotient will be the speed of the driving pulley.

(3) To find the size of the driven pulley, multiply the size of the driving pulley by its speed and divide the product by the speed of the driven pulley. The quotient will be the size of the driven pulley.

(4) To find the speed of the driven pulley, multiply the size of the driving pulley by its speed and divide the product by the size of the driven pulley. The quotient will be the speed of the driven pulley.

It should be understood that the driving pulley is the one that delivers the power, and the driven pulley is the one that receives it. For example, the belt pulley on the engine is the driving pulley, and the corresponding pulley on the line shaft to which it is belted is the driven pulley.

For example, suppose that the normal rated speed of the engine is 400 revolutions per minute, that it is equipped with a 10-inch pulley and that it is desired to have the line shaft run at a speed of 200 revolutions per minute. Then the size of the pulley to which the engine is

belted on the line shaft can be figured by the third rule as given above. ($10 \times 400 = 4,000$, and $4,000 \div 200 = 20$). Therefore, the shaft pulley will have to be 20 inches in diameter.

A method which is perhaps more comprehensive and much easier to keep in mind, is by the use of the following formula:

$$D \times R = d \times r,$$

in which D is the diameter of the driving pulley in inches, R is the speed of the driving pulley in revolutions per minute, d is the diameter of the driven pulley, and r is the speed of the driven pulley.

To illustrate the use of this formula, suppose the pulley (driven pulley) on one of the machines is 10 inches in diameter and that it should operate at the speed of 120 revolutions per minute. If the speed of the line shaft is to be 200 revolutions per minute, then the size of the pulley that should be used on the line shaft can be found by using the above formula, in which $R = 200$, $d = 10$, $r = 120$. Substituting these values in the formula, we have for the diameter of the driving pulley

$$D \times 200 = 10 \times 120$$

$$D = \frac{10 \times 120}{200} = \frac{1200}{200} = 6 \text{ inches.}$$

If one knows the sizes of pulleys used on all his machines and the proper speed at which they should be run, he can by assuming a certain speed for the line shaft, figure the sizes of all the pulleys to be used on the shaft by means of the above formula.

CHAPTER VIII

GAS ENGINE TROUBLES

- I. TROUBLES THAT PREVENT STARTING. II. FAULTY IGNITION. III. DEAD ENGINE. IV. MISCELLANEOUS TROUBLES—CYLINDER TROUBLES. V. PARTS THAT MAY NEED ADJUSTMENT. VI. WORN VALVES. VII. SMOKE. VIII. FUEL SUPPLY. IX. BOUND OR HOT BOXES. X. LEAKY GASKETS. XI. DEPOSITS IN COMPRESSION CHAMBER AND WATER JACKET. XII. CRACKED WATER JACKET. XIII. USE OF POOR LUBRICATING OIL. XIV. CARE OF AN ENGINE. XV. STARTING AN ENGINE. XVI. STOPPING AN ENGINE. XVII. MAGNETO TROUBLES.

TROUBLES — HOW TO LOCATE AND CORRECT THEM

All ordinary troubles encountered while operating a gasoline or oil engine may be divided into four classes:

1. Those that prevent the engine from starting.
2. Those that cause a "dead" engine after running a short time.
3. Those that cause a loss of power.
4. Miscellaneous troubles, such as:
 - Cylinder troubles.
 - Deposit in compression chamber.
 - Worn valves.
 - Smoke.
 - Leaky gaskets.
 - Fuel supply troubles.
 - Bound and hot boxes.
 - Cracked water jacket.
 - Use of poor lubricating oil.
 - Ignitor not properly adjusted.

TROUBLES THAT PREVENT STARTING

Troubles which prevent starting an engine are numerous. Difficult starting may be caused by —

1. Faulty ignition.
2. Slow vaporization of fuel in cold weather.
3. Not fuel enough.
4. Too much fuel.
5. Water in the cylinder.
6. Loss of compression.
7. Improper valve timing.

Faulty Ignition — When it seems impossible to start the engine,

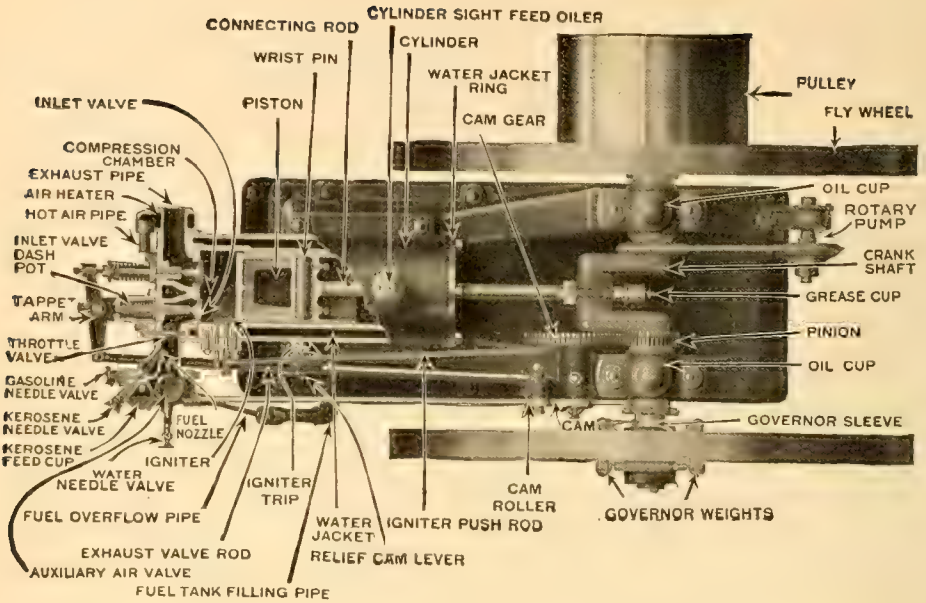

Fig. 1.—Top view of Horizontal Oil Engine.

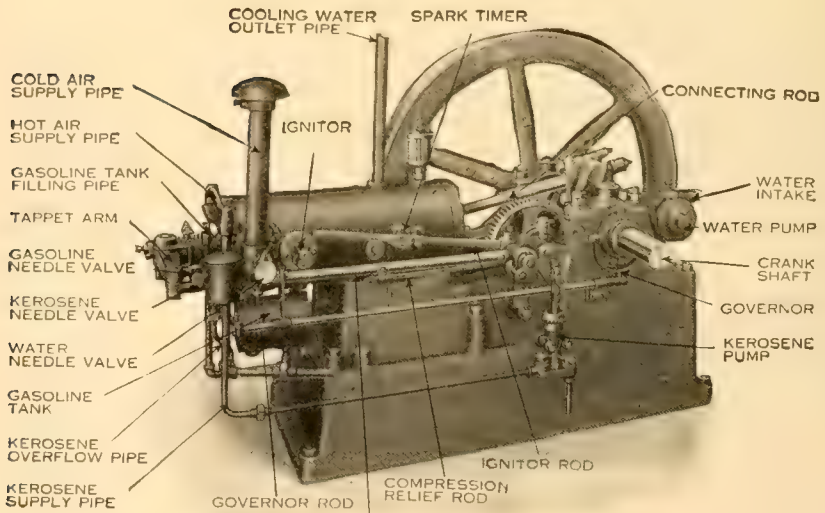

Fig. 2.—Side view of Horizontal Oil Engine (Flywheel removed).

look first for faulty ignition. The indications, causes and remedies for faulty ignition are explained later. The cause of non-ignition, when the engine fails to ignite the first few charges, can not be removed by turning the wheels, but starting will become more difficult the longer they are turned, because the engine cylinder will become flooded with fuel. There is also danger of filling the muffler and exhaust pipe with a rich charge, which when ignited, is apt to rupture the muffler. If the engine does not ignite the charges, there must be some cause for it which cannot be located and remedied by turning the flywheel.

Slow Vaporization—In extremely cold weather fuel evaporates slowly and often gives trouble. In such cases the cylinder jacket should be heated by filling with hot water, and the air-inlet pipe should be warmed with hot cloths. It is sometimes well for starting to heat a bottle of gasoline by holding it in hot water and then pour a small amount of this hot gasoline into the mixer. A better way is to apply external heat to the mixer which will cause rapid evaporation of the fuel. The heated gasoline vaporizes quickly and easily, charging the in-going air.

Not Enough Fuel—The engine will go up to normal speed within a few seconds after starting if it is receiving fuel in proper proportion and the ignitor is working all right. If not under load it should take a charge every seven or eight revolutions and fire each charge. This indicates that the engine is ready for working. If there is popping and back firing in the mixer, the engine may need more fuel, or the inlet valve may not close properly or the ignitor may be out of adjustment.

Too Much Fuel—A dull exhaust and black smoke issuing from the exhaust pipe indicates that the engine is receiving too much fuel, as the charges that are taken in are not all ignited or thoroughly burnt. It is possible to choke down an engine by feeding too much fuel, just as easily as by not feeding enough. Don't feed more fuel when more power is wanted. The engine should cut out a charge every six or eight revolutions when pulling its load under normal conditions. Should the engine be extremely "long" on gasoline; that is, flooded, the charge will not ignite at all. In such cases the gasoline must be shut off and the flywheel revolved several times to work out the excess of fuel. This is easily done by holding one of the valves, preferably the exhaust valve open, while revolving the wheels. Flooding of the cylinder is frequently the cause of the engine's failing to start.

Water in the Cylinder—If water is found in the cylinder it must be removed and the leak stopped before the engine is started. A leak is frequently so small that it does not affect the running of the engine after it has started. However, when the engine is idle this small leak will let in enough water to prevent starting.

Loss of Compression—Poor compression, due to improper seating of one or more of the valves, or to a poor fit of the piston or its rings, may prevent the engine from starting.

Valve Timing — If the valve timing is especially bad, the engine will fail to start. Revolve the flywheel slowly by hand and note the position of the crank shaft during various movements of the valves. The movements of the exhaust valve only are given because the inlet valves operate automatically through the suction produced by the piston; in other words, the exhaust valve is the only mechanically operated valve.

When the crank shaft is about 5 degrees over the inner center, the exhaust valve should close. Turn it slowly 5 degrees more, at which point you will note that the inlet valve automatically opens. Continue to turn the crank shaft until it reaches a point about 25 degrees from the outer center, then one complete revolution, at which point the exhaust valve should open and remain open until the crank reaches the original starting point — 5 degrees beyond the inner center. In the meantime the inlet valve which opens at 10 degrees beyond the inner center has been automatically held open until the crank shaft makes practically half a revolution, that is, until it reaches a point 10 degrees beyond the outer center. These opening and closing points vary slightly for the different sizes of engines.

FAULTY IGNITION

The indications and causes of faulty ignition are numerous and a source of frequent trouble.

Indications

1. Difficult starting.
2. Thumping in the cylinder.
3. Loud report at the end of exhaust pipe.
4. Misfiring.
5. Premature firing.

Causes—The causes of these troubles on make-and-break ignition are as follows:

1. Disconnected switch.
2. Loose wires.
3. Exhausted batteries.
4. Gummed or corroded electrodes.
5. Dirty ignition points.
6. Short circuit.
7. Spark not properly timed.
 - (a) Engine may be out of adjustment.
 - (b) Parts may be worn.
8. Pre-ignition.
 - (a) Red-hot deposit in cylinder.
 - (b) Improper mixture.

The causes of these troubles in jump-spark ignition are those mentioned above with the addition of the following:

9. Improper adjustment of the vibrator on coil.

10. Dirty contact points on the timer.

11. Dirty or faulty spark plug.

All of these troubles, excepting disconnected switch and exhausted batteries, arise also when a magneto or dynamo is used.

If the batteries are used, test the battery current by closing the switch, disconnecting the end of one of the wires and brushing it against the binding post to which the other wire is attached. (Fig. 5.) If a bright spark does not show every time the wire is snapped or slipped off the binding post, there is something wrong with the current or the conductors. It may be a disconnected switch, loose wires, or exhausted batteries.

If there is a good spark on the end of the wires, and a weak one or none at all at the point of contact of the electrodes, there is something wrong in the

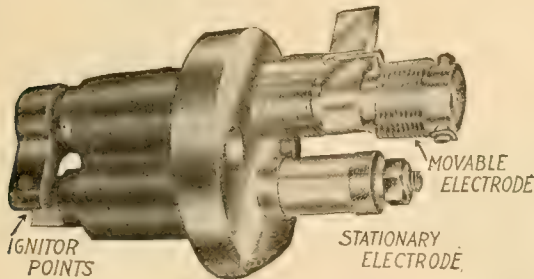

Fig. 3. Make-and-break Ignitor.



Fig. 5. Testing wire on binding post

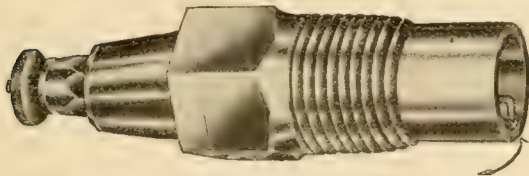

Fig. 4. Spark Plug. X indicates point of jump spark.

sparkling mechanism of the engine — the mechanism is either corroded, gummed up, short circuited, or out of adjustment.

If a magneto is used and you have trouble with the ignition, look first for something wrong in the electrical system of the engine — look for corroded or grounded ignitor points, disconnected wire, bad insulation on stationary electrode or magneto, and breaking of ignitor points out of time. If investigation convinces you that none of these are causing the trouble, then the magneto itself is out of adjustment. In this case proceed along the lines laid down under "Magneto Troubles."

Disconnected Switch — Be sure that the switch is on before starting the engine, and be sure that it is off when stopping the engine. Many an operator who failed to start his engine has found that the switch was not on.

Loose Wires — Use nothing but insulated copper wires and see that all the wires are well attached to the binding posts. It frequently happens that a wire becomes loose and thus prevents a good spark.

Exhausted Batteries—The indications of an exhausted battery are misfiring and the final dying down of the engine. An engine may run a few hours on a weak battery and then stop, and no amount of coaxing will start the engine. Perhaps the next day it will repeat the performance. The reason it can be started the next day and not immediately after it has stopped the day before is that during the interval the batteries recuperate sufficiently to run the engine a short time. Therefore, if the engine will run a few hours at a time each day and then stop, the batteries are too weak for continuous running.

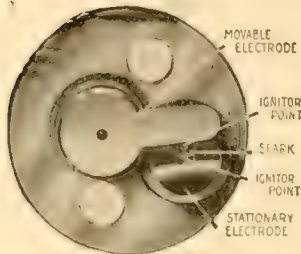

Fig. 6. Make-and-break Ignitor.
X shows point of spark.

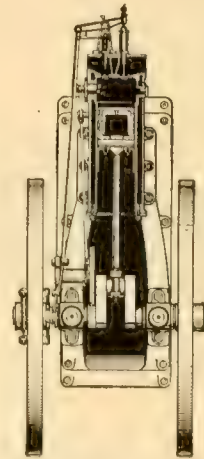

Fig. 7. Point of Ignition,
near end of Second Stroke.

A good battery, either a fluid or dry cell, should give an igniting spark from two to six months, depending upon the amount of work done by the engine. Should the engine be operated continuously for ten hours every day, the battery may have to be renewed after two months. A battery can be likened to a bottle which holds so many drops of water, which, if allowed to drip out drop by drop, will last a certain length of time, but which, if left to flow out in a continuous stream, will soon be empty. So with the battery. It contains so many sparks which, if judiciously handled, will last a long time. If, however, the switch should be left on over night, or when the engine is not in operation, the battery may be completely exhausted by morning.

A battery may not be entirely exhausted and yet fail to give an igniting spark. A spark of this nature is too weak to ignite the charge in the cylinder. An effective spark which will ignite the charge is a single blue-white spark at the point of contact. A dozen small sparks will not ignite a charge — and that indicates trouble along the line.

It is poor economy to attempt to run an engine on weak batteries.

Gummed or Corroded Electrodes—It is frequently found that the movable electrode becomes gummed or corroded, due to the accumulation of oil and dirt. This will prevent a good spark. (Figs. 3 and 6.)

The ignitor should be oiled with gas engine oil every time the engine is started and should work perfectly free. A good time to oil the ignitor is at the time of stopping, because this allows the oil to work around the moving parts, and does not permit it to be blown out so readily by the compression. Use kerosene once or twice a week to cut the gummy oil, oiling thoroughly thereafter. Much trouble is caused by a tight-working, movable electrode; be sure that this works free and easy.

Gummed Ignitor Points — Examine the sparking points and see whether they need cleaning or renewing.

The sparking points can be cleaned by lifting up on the ignitor hammer so that the sparking points come together, and pushing in on the movable electrode several times, which has the effect of sliding one point upon the other — cleaning them.

The ignitor should be cleaned about every thirty days. Carefully remove any deposit that may be on the points, and, if pitted, smooth with a file. The stationary electrode is insulated from the body of the ignitor and should not have any metallic contact with it. (Figs. 3 and 6.)

Short Circuit — An external short circuit results if a wire from the battery to the engine should have its insulation broken or worn at a point where it touches some pipe or iron that in any way communicates with the other wire. Broken insulation may short circuit the spark coil. The character or appearance of the spark, especially if it is of a scattering nature, indicates a short circuited spark coil.

Timing of the Spark — If electric ignition is used, be sure that the spark is properly timed. The ignitor on make-and-break ignition should trip and the electrodes should separate just before the end of the compression stroke is reached, which is just before the crank reaches the inner center. (Fig. 7.) This is allowing for the instant of time elapsing between the sparking of the ignitor and the actual ignition. The force of combustion does not come simultaneously with the making of the spark so that the compression stroke is completed before the force of combustion really begins. On the other hand, if the ignition apparatus should be timed to spark just at the end of the compression stroke, actual expansion due to the combustion will not take place until the piston has traveled about one-fourth of the distance on its outward stroke. This short lapse of time between the spark and the actual ignition makes it necessary to time the spark before the piston reaches the inner center.

Early Ignition — Care should be taken to adjust the ignitor so that it will not spark too early, because if it does the combustion will be exerting an outward pressure while the piston is actually traveling inward, so that the engine will be working against itself. The momentum of the flywheel will carry the piston against the enormous outward pressure which the expanding gas exerts. This materially decreases the power, because the engine must overcome the tendency to reverse, caused by the premature sparking.

Too early ignition produces a distinct pounding noise which is easily detected.

In making any change in the timing adjustment of the ignitor, be careful that the length of time of contact is not too short to give time for the battery to establish a good flow of current through the spark coil. This would result in a very poor spark, poor ignition, sometimes no ignition at all. The mixture in gas engines, if ignited with a snappy, good, hot spark, produces good working force; if ignited with a weak, lazy spark, it will burn slowly, with little force and poor results.

Causes of Early Ignition — The causes of early ignition are: first, the engine may be out of adjustment; second, the parts may be worn.

Sometimes the parts of an engine are changed accidentally by some one taking off a part of the engine and not putting it back in correct position — often a cam shaft is removed and when put back the gears are not meshed with the same teeth together. A difference of only one tooth will throw the whole engine out of time.

On a small gear or pinion, which is just one-half the size of the large gear, one tooth is marked, and two teeth are marked on the large gear. If the gears are removed for any reason, they must be replaced so that the marked tooth on the pinion works between the two teeth marked on the gear.

All igniting mechanisms wear in time and require some adjustment. The points may gradually wear and by so doing change the time. It often happens that owners of engines report a broken crank shaft and say that the time of ignition has never been changed since they got the engine. The fact that nothing has been done to the engine does not guarantee that the time of sparking has not been changed. The very fact that they say they have not adjusted the engine shows that they have not made allowance for wear.

When the engine is new and before parts get out of adjustment, it is well to make some mark to show the position of the crank shaft when the ignitor trips. Thus it will be possible for the operator to tell at any time whether the engine is igniting at the proper time.

Pre-Ignition — Premature ignition is indicated by a pounding in the cylinder. Premature ignition is usually caused by a red-hot deposit in the cylinder, improper mixture, or overheated cylinder.

A projecting point of iron or a sooty carbon deposit in the cylinder will become red hot and ignite the charge prematurely. Little particles of burnt carbon accumulating from the burnt cylinder oil in the combustion chamber may constantly remain heated to the ignition point and ignite the charges prematurely. If pre-ignition continues, examine the cylinder and if a deposit is found, remove it and clean the cylinder thoroughly.

An improperly proportioned mixture of fuel and air may result in such slow combustion that it is still burning when the next charge is admitted.

In this case the new charge will be ignited just as it enters the cylinder and will fire back through the mixer.

An overheated piston may be the result of a poor circulation of cooling water, or lime or mud deposit in the water jacket. A lime or mud deposit in the water jacket will eventually bake hard and retain enough heat to cause pre-ignition. Clean the jacket thoroughly. An overheated piston on the air-cooled engine may be caused by an overload on an engine. When the cylinder of an air-cooled engine gets hot enough to cause pre-ignition, about the only thing to do is to remove the load and permit the cylinder to cool.

If the charge fails to ignite on an air-cooled engine, there may be trouble with the spark plug, with the batteries and conductors, or with the spark coil. Remove the spark plug from the cylinder, lay it on the end so that there is a metallic contact and test for spark. (Fig. 8.) If there is no spark, examine for disconnected switch, sooty plug, broken insulation

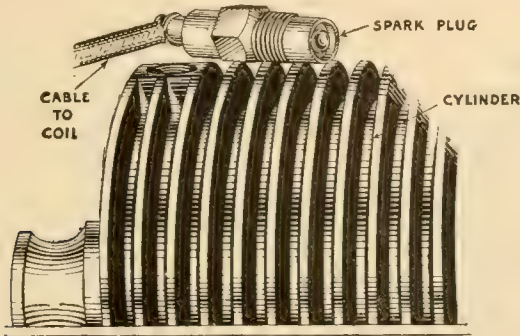

Fig. 8. Testing a Spark Plug.

or plug, spark points too far apart or too near together, loose wires, short circuit, dirty vibrator points, or exhausted batteries. If these are found in order, test the spark coil.

Adjustment of Vibrator on Coil — With jump-spark ignition this difficulty is apt to be met. When the batteries are new the current may be so strong that the vibrator is held against the induction coil so that it will not buzz. Loosen the set screw to increase the distance between vibrator and coil until a strong buzz is heard. This indicates proper adjustment. If the batteries are weak the distance between the vibrator and coil is apt to be so great that the coil cannot draw the vibrator to it. In this case it will not buzz. If the indications point to a weak battery, adjust the set screw to lessen the distance between the coil and vibrator until a buzz is heard.

Dirty Contact Points on Timer — This is another jump-spark ignition trouble. Oil or dirt is liable to gum up the contact points so that when they come together the dirt will prevent a connection and the coil will then refuse to work.

Batteries — Batteries are of two common types, wet batteries and dry

batteries. Wet batteries are made with the chemical in a liquid form. When exhausted, the zinc and the chemical can be renewed at a nominal cost. Dry batteries are considerably smaller and more compact than wet batteries, but cannot be renewed. A temporary revival can often be obtained by boring a hole in the top and pouring in a little vinegar or even water.

The current from a battery is generated by chemical action. When the chemicals are so weakened from constant or long use that little chemical action takes place, the batteries will not deliver enough current to make a good spark.

It is advisable to use the same kind of cells throughout. If dry cells are used, see that they are of the same size. If wet cells are used, see that they are the same size and construction. In order for a battery to work well all the cells should give the same voltage and current. Cells of different size and construction do not do this.

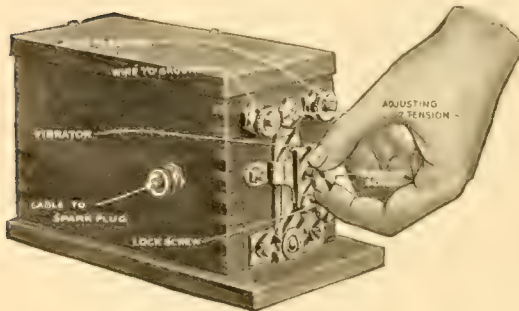

Fig. 9. Adjusting Vibrator on Coil.

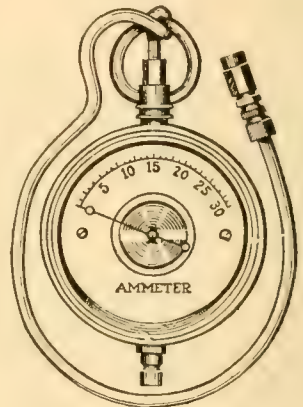

Fig. 10. Ammeter for testing Batteries.

Very often when a battery becomes weak it is only on account of one or two cells. Each cell should be separately tested with an ammeter, and the weak cells drawn out. Fresh cells should not be added to an old set before having tested each of the old cells, as one weak cell will weaken the whole battery. Do not test dry cells for amperage while they are cold, as cold weather temporarily reduces the initial amperage. Place the cells in a fairly warm place, about 70 degrees temperature, and the amperage will rise to normal. The total output of the battery is the sum of the number of amperes given by each cell, and the total voltage of the battery is the total number of volts given by each cell. Generally speaking, a current of eight amperes at a voltage of over four is required for making break ignition. For jump-spark systems, over ten amperes is required at about a voltage of four.

DEAD ENGINE

An engine may slow down after starting and finally stop dead after a short run. The cause may be one of the following:

1. Irregular ignition.
2. Over-heated cylinder or piston.
3. Hot journal, crank or wrist boxes.
4. Overload on engine.
5. Exhausted fuel supply.
6. Leaky valves or sticking exhaust valve.
7. Ignitor points scaled over.
8. Alkali water through mixer.

Irregular Ignition — If there is a broken wire connection, repair it, clean the electrode or ignitor, repair the insulation, renew the battery, examine the spark coil, magneto, or dynamo.

Over-Heated Cylinder or Piston — If these parts are over-heated, increase the supply of cooling water and lubricating oil. If the engine is air cooled, remove the load and allow the cylinder to cool.

Hot Journal, Crank, or Wrist Boxes — Stop the engine and examine the hot box. Never apply water to a hot phosphor bronze bearing. If the box is cut, file or scrape all the rough places and then clean thoroughly. Then readjust the boxes carefully to the bearings, lubricate well, and start the engine. This bearing should be watched closely for several days and if it shows any tendency to heat, examine it again and readjust it.

Overload on Engine — An overload will choke down an engine in a short time. Reduce the load.

Fuel Supply Exhausted — It frequently happens that the fuel supply is exhausted, which causes the engine to stop. The engine won't run on air alone. Replenish the fuel supply.

Leaky Valves — The valves may leak so badly that the engine will gradually die down and stop. Test for leaks, as explained on the next page, then, if necessary, regrind the valves.

LOST POWER

The loss of power is due principally to:

1. Leaky valves.
2. Worn piston rings.
3. Misfiring.
4. Choked inlet and exhaust passage.
5. Back firing.

Leaky Valves — If the valves are leaky they permit loss of compression. They should be taken out at once and cleaned or reground, if necessary, so that they seat perfectly. See that they work free and easy in the valve guides. If the stems are gummed up, use a little kerosene to loosen them. Leaks in valves may be detected by turning the engine against the compression and listening for escaping charge. If the valve leaks, it must be reground unless the leak is caused by dirt under the seat of the valve.

Worn Piston Rings — If the piston rings are worn and allow the escape of the explosive force, they should be replaced by new ones. In this

case it is often necessary to put the piston into a lathe and true up the grooves to fit the new rings. If any leak is discovered about the cylinder, it should be properly packed or plugged at once.

Misfiring — When the engine fails to fire each charge, it misfires. This has been thoroughly discussed and remedies given under the caption "Faulty Ignition." The remedies consist in examining insulations of the electrode, all connections, and the battery to determine whether it is exhausted or not. Also see if there is any broken connection, and whether the electrode or ignitor points need cleaning or other attention.

Choked Inlet or Exhaust Passage — An obstructed passage may be caused by lost motion through wearing of the cam and cam wheel, which prevents a full and free opening of the valve.

Back Firing — When a flame comes out of the mouth of the mixer or air pipe it is termed back firing. A delayed combustion of the previous charge is the principal cause of back firing. If the air as it enters

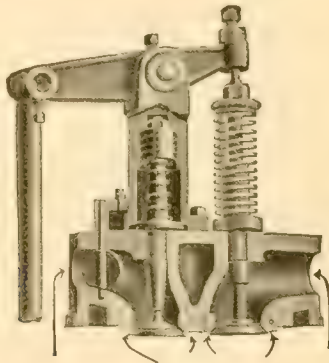

Fig. 11. Section of Oil Engine Cylinder Head to show valve arrangement.

the cylinder does not receive a sufficient charge of fuel it makes a slow-burning mixture. This sometimes burns so slowly, not only on the working stroke, but also on the exhaust stroke of the piston, that sufficient flame remains in the cylinder to fire the fresh incoming charge, which, of course, must escape back through the mixer because the inlet valve is open.

The incoming charges may be ignited by an incandescent foreign substance in the cylinder, which will also cause back firing.

Back firing might also be caused by a tight working inlet valve or by something obstructing the passage of the fuel in the mixer.

The remedy for back firing, if caused by weak or slow-burning mixture, is feeding a little more fuel. If this does not remedy it, the cause is probably some incandescent foreign substance in the cylinder which should be looked after and removed.

MISCELLANEOUS TROUBLES — CYLINDER TROUBLES

If there is a pound or noise in the cylinder, look for :

1. Pre-ignition.
2. Badly worn or broken piston rings.
3. A badly worn piston.
4. Loose piston pin or bearing.

Pre-ignition — The causes and remedies of pre-ignition have been described under those heads. The sound produced by pre-ignition is a deep, heavy pound. If caused by pre-ignition this pound will cease as soon as the carbon deposit, or the heated projecting point which causes the firing is removed from the cylinder. Test for pre-ignition by cutting off the electric current. If the engine continues to fire its charges without a spark and a pounding noise is heard, it indicates that the pound is due to pre-ignition. If, however, it fails to ignite charges the instant the current is cut off, it is safe to conclude that there are no hot projecting points or carbon deposit in the cylinder. If the pounding noise continues it may be caused by a tight piston, not enough fuel, a poor mixture, too early ignition or on an oil engine insufficient amount of water in the mixture. A tight piston causes a pound in the cylinder when the engine is under heavy load. Supply oil to cool and lubricate the piston.

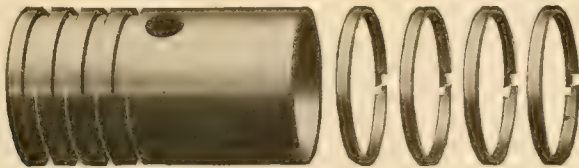

Fig. 12. Horizontal Engine Piston and Piston Rings.

Badly Worn or Broken Piston Rings — If there is a barking noise in the cylinder, it indicates the escape of the expanding gas past the piston rings. If these rings are worn to this extent, they should be carefully expanded or replaced by new ones well fitted into their grooves so that they bear on the cylinder wall at all points of their circumference.

A Badly Worn Piston — A badly worn piston will likewise allow the expanding gas to escape, which causes a barking noise. Replace the piston.

PARTS THAT MAY NEED ADJUSTMENT

Every thump or noise heard about the engine when in operation does not indicate that there is trouble in the cylinder. It may be that there is:

1. A loose cross head or wrist box.
2. A loose crank pin box.
3. A loose crank shaft box.
4. A loose nut on the journal box cap.
5. A loose flywheel or pulley on the shaft.
6. Lost motion in any bearing, gear, or in the governor.

Examine all these parts carefully and tighten all loose nuts. A loose

flywheel is indicated by a thumping and frequently a sort of metallic or grating sound. A thud or a pounding noise indicates a loose cross head or crank pin box. A loose nut or a cracked rim, spoke or hub on the pulley or flywheel usually makes a clicking noise.

Listen carefully for the noise which will indicate by the character of its sound what part of the engine needs attention.

WORN VALVES

If a valve needs grinding, remove the cylinder head, take the lock nuts and spring from the stem, lift out the valve and examine the seat. (Fig. 14.) The valve needs grinding if it does not show a good bright bearing all around. Proceed as follows: Apply lubricating oil to the seat of the palate, then sprinkle on some flour of emery and drop the palate into the seat. Turn the palate round and round for a time with a brace and then back and forth in a semi-circle, alternating the movements. (Fig. 13.) It is well to lift the valve palate occasionally from the seat, then let it drop back and repeat the grinding movements. Take out the valve when it turns without any apparent grinding friction. Wipe it clean, examine it, then apply more oil and emery, and grind it again.

When you are sure that you have secured a good bearing seat, wipe the valve palate and stem, as well as the valve seat and guide in which the stem works, free from emery, oil, and grit; then return the palate to its seat, close up the valve, and adjust the spring. If you have difficulty in replacing the spring, compress it in a vise, and tie it with wires. When in position, cut the wires. Lock the nuts on the stem ready for service.

Inlet Valve Dash Pot on Oil Engine — Throttling governor engines having automatic inlet valves are equipped with an inlet valve dash pot to prevent the valve from closing with such force as would cause breakage. On engines equipped in this manner, a small piston is attached to the stem of the inlet valve, and this piston works in a cylinder fitted with a relief cock, which governs the action of the inlet valve, both in opening and closing. This cock should never be entirely closed but should be adjusted to position where inlet valve works freely and with least noise. If the dash pot piston becomes sticky from gummed oil, a little kerosene let in through the relief cock will loosen the piston so it will work freely.

SMOKE

1. Black smoke at the end of the exhaust pipe or muffler means an over-supply of fuel, blue smoke indicates too much lubricating oil in the cylinder. The needle valve should be set to feed less fuel, and if this does not stop the smoke, less lubricating oil should be fed into the cylinder.

Smoke at the open end of the cylinder is generally caused by overheating or by "blowing" of burned gases past the piston. If the lubricating oil is burning, it is an indication that the cylinder is overheated or that the

oil is inferior, which necessitates an increased supply of cooling water. If it is an air-cooled engine it will be necessary to remove the load and allow the cylinder to cool. If the smoke continues, take the piston out, fill it with water, and test for a leak. When the piston is out, examine the rings carefully. If they are worn, replace them.

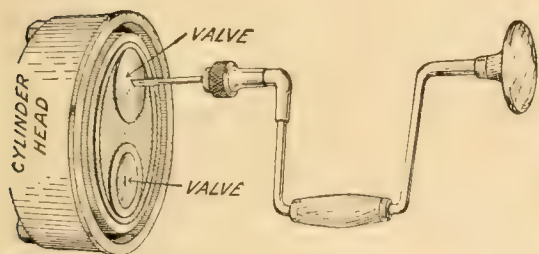

Fig. 13. Method of grinding valves.

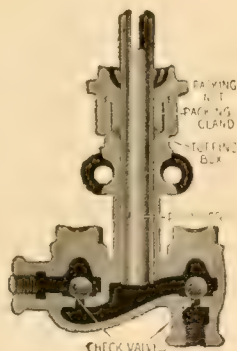

Fig. 15. Section of horizontal engine fuel pump.

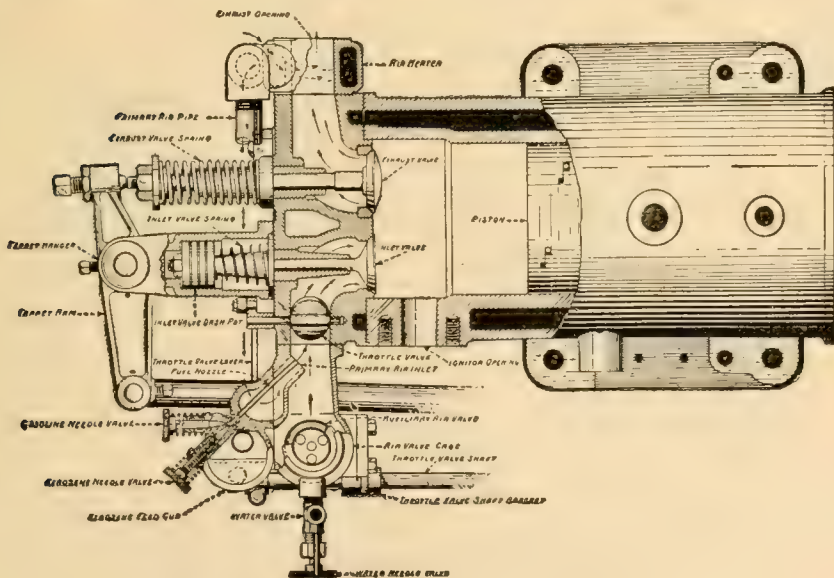

Fig. 14. Sectional view of I H C Oil Engine Cylinder Head.

FUEL SUPPLY

It is sometimes difficult to keep a proper supply of fuel up to the engine, which may be due to the following causes:

1. Improperly seated check valves.
2. Leaky suction or supply pipe.
3. Water in the fuel.
4. Clogged fuel nozzle in mixer.
5. Clogged pipes.

Improperly Seated Check Valve—If dirt or sediment gets into the check valve, it prevents the valve from seating properly, which allows the fuel to flow back to the tank. Clear the valves of dirt and sediment in case you have this difficulty.

Leaky Suction or Supply Pipes—The suction or supply pipe may have a leak. When this pipe is connected with the engine, it should be thoroughly tested to be sure that there are no air leaks in it, for if bubbles of air work into the pipe, they will cause the pump to lose its priming. The joints of this pipe will hold well if put together with common laundry soap. Do not use white or red lead.

Water in the Fuel—Water in the fuel is a common source of trouble, and is often difficult to detect. When pure gasoline or kerosene is scattered with the finger on a piece of metal, it will spread out smoothly all over it, but if there is water in it there will be little globules that run around very much like quick-silver does when scattered on anything. An

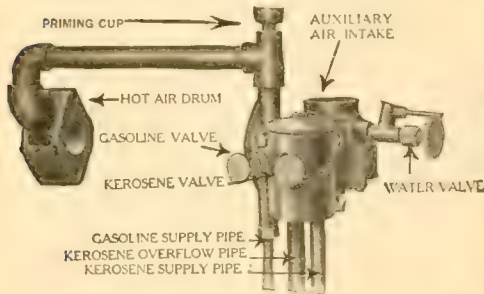

Fig. 16. Section of Horizontal Engine Kerosene Mixer.



Fig. 17. Main crank bearings, horizontal Engine.

easy method of removing water from fuel is to strain the fuel through a chamois skin. All the water will remain in the chamois skin, while the fuel will run through.

Clogged Fuel Nozzle in Mixer—The needle valve nozzles in the mixer are apt to clog with dirt or sediment. To clean, remove the needle valve and plug and insert a small wire into the nozzle opening.

Clogged Pipes—It sometimes becomes necessary to disconnect the fuel pipe, and clean it out, as there is always a certain amount of sediment in fuel, which, if not removed by straining the fuel when filling the tanks, will clog at some elbow or roll about in the pipe and thus hinder the full flow of fuel.

BOUND OR HOT BOXES

Bound Boxes—When the cross head, crank or journal boxes become so warm that they shoulder tightly after all the liners are taken out without correcting the lost motion or knock, their shoulders must be filed or they must be put in a shaper and dressed so that they can be set

snugly to the bearing which they encircle without shouldering by from $1/32$ to $1/8$ of an inch.

Setting a Box — A box should never be set so closely that it binds the bearing it encircles, but it should be set close enough to prevent pounding. Tighten the nuts up equally while holding the box. Bring them up gradually together, never tightening one nut before bringing up the other. After the box has been set, turn the wheels over to see if it works tight and stiff. If it does it has been set too tightly. Judgment must be exercised in setting a box. It cannot be done in a hurry, and it should not be done carelessly.

Hot Boxes — Watch all the bearings on the engine closely, especially when new. If any of them run hot, stop the engine and examine carefully for the cause. If too tight then the nuts should be loosened up a little. If the box binds on one side of the bearing, file or scrape it down carefully where it shows the most wear. If there is a burr or high point on the bearing or box, dress it down smooth, but do not let the box run hot very long at a time.

LEAKY GASKETS

All joints subjected to heat and pressure are packed with fibre sheet gaskets. If the gasket becomes torn in removing any part that is packed, a new gasket must be put in. Cut this gasket very carefully so as not to break or tear it. Use packing that is not broken up by folding. The thickness to use is known as $1/16$ " for cylinder heads and ignitors, and $1/32$ " thick for mixers and exhaust flanges. Fiber sheet packing is the most economical to use. Carefully remove every bit of the old gasket before putting on the new one. Use care in tightening the bolts; tighten these uniformly before starting, and again as soon as the engine has been warmed up. Never use a chisel in removing a part from the engine — you might bend the part so that no gasket would hold.

DEPOSITS IN COMPRESSION CHAMBER AND WATER JACKET

A hard, tarry deposit will gradually form in the compression chamber. This should be carefully removed at least every month. Sometimes oftener, if the kerosene used carries much of the tarry substances. Whenever removing this, clean the valves, ignitor, and the piston and piston rings. Use kerosene to remove the gum from the piston rings. Keep all grit out of the cylinder and piston rings.

A deposit may also be caused by running the engine with a cold cylinder, because the kerosene does not vaporize properly and will gum up inside of the compression chamber and cause trouble.

Also examine the water jacket, as some waters will form a limelike deposit therein. This should be removed with a solution of soda, and the

use of a chisel if necessary. Too much of this deposit is indicated by the engine's heating excessively.

CRACKED WATER JACKET

Freezing the water in the water jacket of an engine cylinder and thus cracking the cylinder is a common occurrence in winter.

Iron gives off heat very rapidly, consequently it quickly returns to the temperature of the surrounding atmosphere. Now, as the sheet of water around the cylinder in the water jacket is very thin, it is evident that if the water is not taken out of the cylinder at night, it will freeze if the temperature drops below freezing. Water in bulk retains heat much longer than a thin sheet of water, consequently the thin sheet in the water jacket will freeze on some nights when a pail of water standing near the engine will not have even a crust of ice on its surface.

When water in the cylinder jacket freezes it rarely causes the cylinder itself to crack, so that there is no damage to the interior of the cylinder, but it will frequently cause the outer wall to crack. (Fig. 19.)

A crack of this nature can be repaired by the owner if he is at all handy with tools. A small size drill for drilling a row of little holes on each side of the crack, about an inch from it, a tap to thread these holes, some screws to fit a sheet of iron plate, a screw-driver, asbestos; a cold chisel and a little white lead are necessary to do the work.



Fig. 18. Horizontal Engine Connecting Rod.

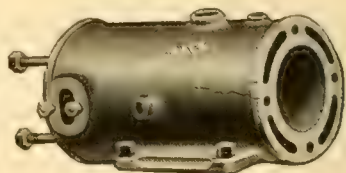

Fig. 19. Cracked Cylinder.

The first thing to do is to cut with the cold chisel a V-shape crease along the crack from one end to the other, then cut the sheet iron plate so that it will cover the crack and extend one inch on each side, and the same distance beyond each end, lay it over the surface of the cylinder and shape it so that it fits closely; next drill a row of small holes around the edge of plate, about one inch apart, large enough to admit the screws. Then place this plate directly over the crack in proper position and drill corresponding holes in the jacket, a size smaller than those in the plate and thread them with a tap. Now put some white lead paste in the V-shape crease over the crack, saturate some of the asbestos wick with white lead and place it directly over the crease with entire length and a little beyond the ends of the crack; then cut out a sheet of asbestos about the size of the plate inside the holes which have been drilled around the edge; soak this in water, place it over the wick and crease and then fasten the plate down securely over all by means of the screws.

In making a patch of this description be sure that all the paint has been scraped off the cylinder where the patch is being made. After the patch has been put in place it can be smoothed down by a file, and then the engine should be allowed to stand for several days before using.

A patch of this description will be found adequate in most cases.

USE OF POOR LUBRICATING OIL

Only the best gas engine oil (high fire test oil) should be used in the cylinder. Ordinary lubricating oils, steam engine oils, etc., will burn and cause the piston to stick and the engine will lose power if it does not stop altogether.

CARE OF AN ENGINE

So far as possible one man only should be held responsible for the care and condition of an engine and its surroundings. In this way an operator will know an engine thoroughly, and failure of the engine to do good work will not result from error on the part of those who are incompetent and are not familiar with such machinery.

Cleanliness is of great importance. Unless the engine is handled systematically and carefully, it cannot be expected to do its work properly. Bearings must not be allowed to become so loose that hammering becomes noticeable. When an engine is run regularly every day, the piston and valves should be removed from the cylinder, and these parts and the cylinder itself should be washed with kerosene or gasoline very frequently. For intermittent work the condition under which the engine is to operate will determine the number of times it must be cleaned in one year. To give the proper results, in no case should an engine be allowed to stand more than six months without being dismantled and thoroughly cleaned. The piston rings should be carefully inspected before replacing the piston in the cylinder, to make sure that they work freely. If the valves, particularly exhaust valves, show even a small amount of leaking, they should be ground to a good seat with flour of emery, or with ground glass mixed with lard oil. The ignitor should be removed about once every week and the points cleaned with sandpaper or a fine file. The spark producing mechanism is accurately adjusted and timed before shipment from the factory. The timing of this spark should be examined frequently to make sure that the setting has not changed.

Batteries should be given most careful attention. Dry batteries should be kept in a dry place and away from vibration. If the spark becomes weak each cell should be tested by itself, and any one cell which is found dead should be removed and a new one should be put in its place.

The elements of a wet battery should be renewed about every six months. When this is done, instructions furnished with these parts should be followed closely.

All contacts should be tight, all wires insulated copper and all wires at connections should be bright and clean.

STARTING AN ENGINE

It is always best to have some regular way in which to start an engine. The following is recommended:

1. See that the fuel supply is ample.
2. Oil the engine thoroughly with gas engine oil, filling every oil cup and noting carefully its adjustment.
3. See that all nuts are tight and that all parts are secure.
4. Close the battery switch and see that the ignition system is in good order. It is best to remove the wire from the stationary electrode and try for a spark by brushing this wire against the circuit breaker on the engine.
5. Try the valves to see if they operate freely.
6. Turn on the cooling water, if a water-cooled engine.

When properly set, the engine should start with two or three turns of the flywheel. It is not necessary to turn the engine for a long time. If it does not start readily, it is time to begin to examine the parts systematically in an effort to find something wrong.

STOPPING AN ENGINE

After stopping the engine, close all oil cups, close all needle valves, drain the water from the cylinder jacket and from the cooling tank. If the engine is to be shut down for a short time only, and there is no danger from freezing, the cooling tank need not be emptied each time. See that the exhaust valves are left closed to prevent corroding of the valve seats and injury to the inside of the cylinders, and be sure that the battery switch is left open. If an oil engine the kerosene and water should be shut off before stopping and the engine run on gasoline for a minute to clean the water and oil from the cylinder and valves.

MAGNETO TROUBLES

If you have determined that the trouble which prevents your engine from starting is due directly to a magneto trouble, and not to some difficulty in the electrical system of the engine, then proceed along the lines explained below.

Sometimes an engine operator, whose engine frequently misses fire, purchase a magneto with the idea that the magneto will prove a cure-all for his engine troubles. A magneto is not a cure-all for every engine trouble. In fact, the nature of the principles upon which it operates makes necessary a construction which occasionally causes trouble that will baffle any but a most expert electrician. Magneto manufacturers will tell you if, after you have installed your magneto on the engine, you

do not get satisfactory results, to go over the printed instructions, which they send, a second time; then, if you cannot locate the trouble, write them in detail or take the magneto off and send it back. This is very good advice. If the magneto doesn't work, write the factory, or send back the magneto and operate your engine on batteries until the magneto is returned to you.

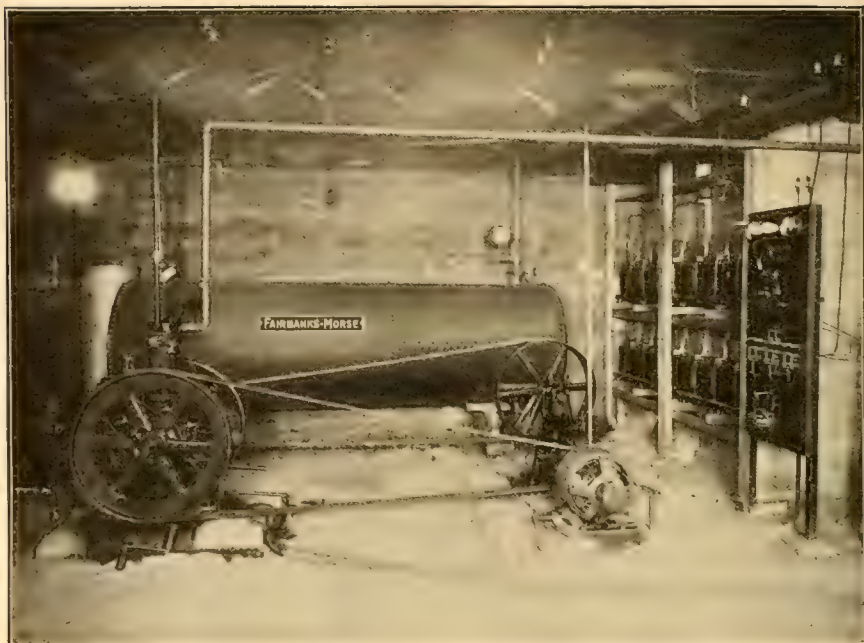

Fig. 1.—A combination electric lighting and pumping plant operated by a gas engine.

CHAPTER IX

CARE OF THE ENGINE

- I. CLEANLINESS MOST IMPORTANT—WIPING THE ENGINE. II. OVERHAULING—REMOVING THE PARTS—CLEANING PARTS—PISTON AND CYLINDER—CLEANING WATER JACKET. III. CARE OF IGNITION SYSTEM—WIRING—BATTERY BOX—VIBRATOR ADJUSTMENT. IV. REMOVING CARBON DEPOSITS—KEROSENE AND DENATURED ALCOHOL. V. HOUSING THE ENGINE.

The degree of continuous, dependable service which a user receives from his gas engine depends very largely upon the kind of care that is given it. Most farm engines are subjected to the sort of service and conditions that are very severe upon any piece of machinery. The engine that is kept up in good shape at all times and is always ready to operate on a moment's notice, is the one that pays the best, and to keep it in first-class order is time well spent.

Cleanliness—The old saying that "cleanliness is next to Godliness" holds true for the gas engine as well as for human beings. To keep the engine clean inside and out is the most important part of its care; a good habit is to wipe it thoroughly with cotton waste or old rags after each day's use. This will remove any dirt, grease, or grit that may have collected on the different parts, and which would be likely to work into the moving parts and cause rapid wear.

For many kinds of work, farm engines are exposed to considerable dust and dirt, which will be a serious detriment unless it is wiped off the engine frequently.

Another important advantage of wiping off the engine each day is the finding of any loose or lost nuts, which may be tightened or replaced. Serious troubles may be caused by nuts becoming loosened or lost, and for this reason they should be watched carefully so that no serious damage will be done.

OVERHAULING THE ENGINE

Every engine should be overhauled at certain intervals, the frequency depending upon the amount of work that it has to do. The average farm engine should be completely overhauled at least once a year; twice would be better. It should never be left until it is in serious need of it; the oftener overhauling is done the easier it will be, the engine will give better satisfaction, and the expense for repairs will not be as great.

Before starting to overhaul, the operator should endeavor to learn what is needed to put his engine into good running condition again. It should be gone over for leaks in the piping, valves, and other places. The bearings should be examined in order to find out what adjustments are necessary or if any need rebabbiting.

Removing the Parts—In order to give the engine a thorough overhauling, it will be necessary to remove all of the outside parts, such as the carburetor, fuel and water pipes, ignition system, valve mechanism, and other parts, leaving only the cylinder and frame. As each part is taken off, it is a good plan to provide boxes or containers of some sort to keep the different parts separate. That is, the various parts of the ignition system, the valve mechanism, etc., should all be placed in separate boxes by themselves to facilitate the work of reassembling. It is always advisable to have all the bolts, nuts and other parts returned to the same position from which they were taken.

Most manufacturers are now marking the timing gears on their engines, but this is a matter that should be looked into before they are taken off. If they are not marked, the proper way to mark them is with a punch or the point of a cold chisel on the two adjoining teeth of one gear and on the tooth of the other that meshes between them. Then there will be no difficulty in replacing them in their proper position.

Cleaning the Parts—In overhauling the engine every part should, of course, be thoroughly cleaned. A good time to do this cleaning is when the parts are removed from the engine, and, as most of them will be covered with more or less grease, this can best be removed by rubbing them with a stiff brush dipped in gasoline, or preferably kerosene. While the cleaning is being done, one should watch carefully

for any new parts that are needed to replace broken or worn out ones. If it can be done, the best time to do the repairing is as soon as any defect is discovered while taking the engine apart. It can usually be done more systematically that way, and there will not be the chance of missing something.

Overhauling the Piston and Cylinder—The cylinder and piston should have special attention, when the engine is overhauled. If the cylinder and head are not cast in one piece, the latter should be removed. Be careful in doing so not to spoil the gasket, and note at the same time if it needs replacing. After the head has been removed the carbon on the inside of the cylinder should be cleaned out. The jacket space should be carefully examined, and if it is covered with a deposit of lime scale, that should be removed. The method of doing this will be explained further on in this chapter.

With the cylinder head removed the valves should be examined. If they are badly worn, cracked, or bent, they should be replaced with new ones, and if they are not seating properly they should be ground.

Next examine the piston and rings. First observe the general appearance of the piston; if it is bright and covered with oil all over, it is in good condition. Dark, streaked spots on the piston show that the gases are leaking past it, and consequently there is a loss of compression. The rings should work freely in their grooves to be in the best condition, but there should be no lost motion.

The rings sometimes become stuck or gummed into their grooves from the carbon deposits or burned lubricating oil. In this case the best treatment is to set the piston in a pail of kerosene. The kerosene will loosen the carbon, and if there is not too much of it, will wash it out. But if a large amount has collected under the rings, it will be necessary to scrape it with a hardwood stick; never use a cold chisel for this kind of work as many do, as it will scratch the metal. When the rings are put back in place again, the cuts in them should be staggered, as loss of compression will result if they are in line.

To Clean the Water Jacket—After an engine has been run for a time the water jacket often becomes covered with a coating of hard scale, usually of a lime formation. This is more apt to happen where hard water is used, and is found more often in hopper-cooled engines than in others, since the water boils continually in the jacket space. In time this scale becomes so thick that it may seriously interfere with the proper cooling of the engine, and some means are necessary to remove it.

The best method of removing scale that is thick and hard from the jacket is to fill it with a solution consisting of one part muriatic acid and five parts of water. If there is only a thin deposit, a weaker solution would serve the purpose just as well, and would probably be better. The mixture should be left standing long enough to dissolve the scale completely but no longer, as it is apt to attack the metal.

The time that it should stand will depend upon the thickness of the scale, but it will be anywhere from twelve to forty-eight hours. At the end of this time the jacket space should be flushed out thoroughly so that none of the acid solution will remain to eat the metal. If possible, a stream of considerable force should be used, so that the particles of scale that have lodged in the crevices will be forced out. If it is found that the scale has not all been loosened, the above treatment should be repeated until it is.

Care of the Ignition System—In the care of the ignition system one of the important things is the wiring. This is many times the cause of failure to get a good spark. The insulation where it touches parts of the engine is likely to become worn through so that there is a loss of current and the spark is consequently weak. One-piece insulated wire should never be used, as the vibration of the engine will continually bend it back and forth and finally cause it to break. Copper wire consisting of several very small strands woven together and covered with insulation is the best to use. But with this also, care should be taken to see that the ends do not become frayed so that they come in contact with the metal and thus cause a short circuit.

If batteries are used, whether for starting or altogether, they should be placed in a dust- and moisture-proof box to give the best results. Dust and moisture collecting on the tops of dry cells will in time cause them to short circuit. Therefore, they should always be kept dry and clean. The battery box, furthermore, should be used for nothing but batteries. On many farm engines we find it filled with tools, pieces of wire, and junk of all descriptions. This is a bad habit to get into, as tools thrown into a battery box promiscuously are quite likely to break a cell or to lodge in such a way that a short circuit will be caused.

Vibrator Adjustment—The adjustment of the vibrator on the jump spark coil gives many operators a great deal of trouble. In order to get the best spark the blade should neither be too stiff nor too weak. If the adjustment is made so that the blade is too stiff, a greater amount of current will be required to move it. Also where the blade is stiff the platinum points will burn very rapidly. On the other hand, if the blade is too weak, the magnetism that is necessary to move it may not be sufficient to produce a current in the secondary winding of the coil to give a good "juicy" spark. The proper adjustment for the blade is when the coil will give a good spark and when the least possible amount of current from the battery is needed. While adjusting the blade see that the platinum points are clean and flat, so that they will make a good contact.

Removing Carbon Deposits—The source of many troubles with farm gas engines may be traced to carbon deposits, particularly where

users are not thoroughly familiar with the operation of their engines. The problem of getting rid of these deposits is a serious one to many, and one which is too often neglected.

It should seldom be necessary to take an engine apart to remove carbon deposits if this phase of engine operation is properly looked after. Frequent applications of kerosene or denatured alcohol should remove the carbon.

Probably the better of these two remedies is the denatured alcohol. For best results it should be used when the engine is hot. Immediately after you are through using your machine for the day, turn the flywheel over until the piston is in the head-end center position, if it is a single-cylinder engine. Then fill the combustion space with the alcohol and let it stand until the following morning. During this time, if the deposit is not too great, it will be dissolved by the alcohol.

The alcohol will also work in around the piston rings and dissolve any carbon deposit that may have formed there. Caution should be used not to let any of the alcohol get into the lubricating system.

If the engine has more than one cylinder, probably the best method of cleaning it of carbon is to treat one cylinder at a time, each time having the piston in its innermost position. It is a good plan to do this often, if the engine is being used a great deal. By having it free from carbon, the engine will run much more satisfactorily and give less trouble.

Housing the Gas Engine—One of the most important things in the care of an engine is the housing of it. No man can give his engine the very best of care if he leaves it out of doors. It will stand almost any amount of service better than it will exposure to the weather, no matter what the conditions. Such treatment invariably increases the operating troubles many fold.

Farm service at the best is very severe, but an engine that is properly sheltered will not only last longer, but it will also be more dependable. If the farmer is using a farm power house, where most of the belt-driven machines are operated, the problem of shelter is solved. But if it has to be moved about the farm, it should have a special place fitted up in some building where it can be put under cover when not in use or during stormy weather. Wherever it is housed, the shelter should be dry, as a damp shelter is the next thing to leaving it outside.

Properly sheltering the gas engine, as well as other farm machinery, will greatly increase its life and its reliability for continuous service as well. The saving effected by a good shelter will many times save the cost of building one.

CHAPTER X

SELECTING A GAS ENGINE

I. ESSENTIALS IN SELECTING A GAS ENGINE—CAPACITY—RELIABILITY COST. II. PURCHASERS BUY ENGINES TOO SMALL—SHOULD HAVE SUFFICIENT CAPACITY. III. TWO ENGINES DESIRABLE. IV. POWER FOR VARIOUS MACHINES. V. RELIABILITY. VI. CHEAP ENGINES—MOST EXPENSIVE IN THE LONG RUN.

The selecting of a gas engine that will be best adapted to the needs for which it is required is by no means an easy task; particularly is this true when the purchaser knows little or nothing about gas engines and their operation. Most farmers would have no trouble whatever in selecting a grain binder or a mower, because they have used these machines for years and have become familiar with them.

But with a gas engine it is different. Only a small percentage of farmers own one, and farmers in general are not familiar with them and hardly know what to look for when they want to buy.

The problem of selection is an important one and should be given a great deal of thought and study before a choice is made. It is always a good plan, if the purchaser himself knows nothing about engines, to get some one whose judgment he can depend upon and who has had considerable experience in handling gas engines, to help him make a selection. This is undoubtedly the safest way under the circumstances. But if this is done, the man who helps do the selecting should have presented to him in a thorough and comprehensive manner the conditions which it must meet and under which it must operate. He should be thoroughly acquainted with the purchaser's needs in order to advise him to the best advantage.

Essentials—The three principal points to keep in mind in selecting a gas engine are: (1) capacity, (2) reliability, and (3) cost.

One of the greatest mistakes that the average farmer makes in buying a gas engine is that he usually gets it too small. In many cases it may be large enough to run any of the machines that it is required to run when it is first purchased. But the longer he has it the more work he finds for it to do. Consequently he soon finds out that it is too small.

Just what size of engine to buy is a very difficult question to decide. Each machine requires a different amount of power. Taken as a whole, the power requirement of farm machines will probably range from one to twenty horsepower. On account of this fact it is absolutely impos-

sible to get one engine that will operate each machine separately with a high degree of efficiency and economy.

The aim should be to get an engine of such size that it will run any of the machines at full capacity. Yet an engine of this size may be so large that it will not always be economical to use it to run a machine that requires very little power compared to the capacity of the engine. If, however, it can be made to run a number of small machines at a time as pointed out in Chapter VII it is often possible to load it to its full rated capacity, at which it runs most economically.



Fig. 1.—Sawing a winter's supply of wood. Select an engine that is large enough for this purpose.

But it is very often the case in farm work that it is not convenient to run a number of machines at a time. Certain kinds of work require the exclusive use of the engine. In such a case, the more nearly the engine rating corresponds to the amount of power needed the more economical will be the operation.

Many farmers have arrived at the conclusion that they should own two or more engines. Just what the size of each of these should be is a matter which will vary with each individual case, depending upon the size of the farm and the amount of work to be done. As a rule there should be a small "chore" engine to pump water, run the washing

machine, cream separator, churn, grindstone, and other small machines that require but a small amount of power. A larger engine will operate the heavy machinery, such as the silage cutter, husker-shredder, thresher, corn sheller, feed mill, and all machines requiring a large amount of power.

Power for Different Machines—Before deciding upon the size of engine that he wants the farmer should make a list of the machines that he desires to operate with it and the amount of power that each requires. By a careful study of this list he will be able to get a fair idea of the size best adapted to his needs. The following table gives a list of the more common farm machines and the power required by each:

Machines.	Horsepower.
Washing machine.....	$\frac{1}{2}$ to 1
Cream separator.....	1 to 3
Grindstone.....	$\frac{1}{2}$
Pump.....	$1\frac{1}{2}$ to 3
Feed Grinder.....	$4\frac{1}{2}$ to 20
Wood saw.....	3 up
Silage cutter.....	8 up
Threshing machine.....	6 up
Portable grain elevator.....	3 to 5
Milking machine.....	$1\frac{1}{2}$
Cold storage plants.....	$4\frac{1}{2}$ to 25
Corn binder.....	3 to 4
Husker-shredder.....	6 up
Hay hoist.....	3
Well drill.....	6 to 12
Hay press.....	6 up
Churn.....	$1\frac{1}{2}$ up
Concrete mixer.....	3 up

Reliability—There is probably nothing more important in the selection of a gas engine than to get one that is reliable. An engine must be reliable to give good continuous service. Of course, many times the user is more at fault than the engine, but if a good, first-class engine, built by a reputable concern is purchased, and intelligently managed, it can usually be depended upon to give satisfaction. If there are different makes of engines in his neighborhood, the prospective purchaser should study them, always taking into account the way in which they are cared for, in order to arrive at a conclusion as to which would be the best for him to buy. There are many good engines on the market today, and it is best to buy a well-known make from a firm of an established reputation which will make good anything that is not right.

Cheap Engines—A great many make the mistake of buying cheap

engines. It is never advisable to buy one engine just because it is cheaper than another. The purchaser often excuses himself on the ground that "it will do him just as well" as a higher-priced engine. But it will not. It is universally true with the gas engine as it is with almost everything else that the cheap product is the most expensive in the long run.

The farmer may think that he is getting a bargain when he buys a cheap engine. But it should be remembered that the manufacturer who sells his product at a low price must necessarily sacrifice quality of material and workmanship in order to make a profit. The cheap engine is seldom reliable, and when a farmer pays out his money he wants something that will give him good service and on which he can depend whenever it is needed to do any kind of work. The repairs on a poor engine will cost much more than they will on a good one, and the troubles and delays will be more frequent.

CHAPTER XI

CARE OF THE AUTOMOBILE

- I. SHOULD BEGIN BEFORE MACHINE IS PURCHASED—STUDY BOOKS OF INSTRUCTION. II. DRIVING THE CAR—GO SLOWLY OVER ROUGH ROADS—THROWING IN CLUTCH. III. SHIFTING GEARS. IV. STEERING THE CAR—AVOID RUTS—TURNING CORNERS. V. MAKING REPAIRS. VI. OVERHAULING.

The proper care of the farm automobile should begin even before the machine is purchased. Books of instruction should be secured, and these should be studied religiously. The principal thing to be mastered in this connection is to learn the different parts of the car, from the radiator to the pilot lamp, and study their relation to each other and to the operation of the car.

Knowing the make-up of a car, when you have purchased one you can take the book of instructions and study it intelligently. One of the things that needs the most study and care is the motor. If one has had experience in operating stationary gas engines, he will be that much more efficient and capable of handling his automobile motor properly.

Driving the Car — One of the most important things in the care of an automobile is in driving it, and it should be said that the average man is not sufficiently impressed with the extreme necessity of careful driving as a means of greatly lengthening the life and usefulness of his machine. Many country roads are very hard on a car. In traveling over rough spots, through mudholes or sand, and up steep hills the car should be run at the lowest possible speed in order to save any unnecessary wear and tear on it. Traveling over rough roads at a high rate of speed is very detrimental to tires, axles, and springs in particular, but the whole car in fact has to suffer from it.

A very common fault among drivers is that, in starting a car from a standstill, they throw in the clutch too quickly. This makes the car lunge forward with a jerk and causes an excessive and unnecessary strain on all parts of the machine. It usually slows down the speed of the engine considerably, and also causes the rear wheels to slip more or less, which is never a good thing, since it injures the face of the tires. It is not an uncommon sight to see the drivers slip around as much as half a turn.

The clutch should always be thrown in gradually to avoid starting with a jerk. Yet one should not be so slow in setting it that the clutch

faces will become unduly worn. If the car is in motion, as when changing speeds, the clutch can in most cases be thrown in quickly without causing the car to be severely strained.

Shifting Gears — As soon as an automobile is purchased and before the owner attempts to run it, he should thoroughly study the transmission system and particularly the method of shifting the gears. It is not sufficient to know how to operate the different levers merely; it is essential to know the "why" as well as the "how."

In changing from one speed to another, it should be done very carefully to avoid the grinding sound that one so frequently hears and which is very detrimental to the gears, often resulting in "stripping" them. With his hand on the shift lever the driver should try the gears carefully, and when they will mesh the shift should be made quickly. After a little experience and by being careful each time, he will be able to change the speed gears without any difficulty whatever.

It often happens in changing from one speed to another, particularly with beginners, that the motor will attain an excessive speed if the gear shift is made slowly. This should be avoided and can be, by using the throttle lever; for "racing" is detrimental to the motor. If the change of gears is made quickly, the engine will not have time to speed up.

Steering the Car — To properly care for a car one needs to give considerable attention to the matter of steering while he is driving it, particularly over roads that are not in the best condition. Always endeavor to keep the car on the best portion of the road, and if it is filled with ruts they should by all means be avoided, for nothing is much harder upon rubber tires than ruts, especially during the winter when the ground is frozen. It is always better to drive the car over rough ground than to let the wheels run in the ruts, even though it is a little rougher riding.

In driving, the steering wheel should be held firmly in the hands and should not be continually turned first one way and then the other, thus making the car take more or less of a zigzag course. Such steering is hard on the tires, especially if the car is pretty well loaded. The steering wheel should be held still and turned gradually when it is desired to slightly change direction or to pick a better place in the road.

Accidents in turning corners are quite frequent and can just as well be avoided if the driver is careful to make the turn at a slow speed. In going around corners the car should be going slow enough so that the wheels will not skid sideways and injure the tires, break a wheel or axle. The driver should have his car under control at all times, and he will not only have fewer accidents, but he will also be giving it much better care.

Making Repairs — Never neglect to make a repair or adjustment on an automobile whenever it is needed, no matter what the time or the place. It is a great temptation when driving to neglect to make repairs,

if any are necessary, until the trip is over. This is a very bad practice and it quite frequently happens that what might have been a very small thing when it was first noticed will become a very serious thing if the car is not stopped at once and the trouble remedied. The owner may pay out many dollars to the repair men, when a few minutes' stop on the road would have avoided all the trouble and expense. Many times small repairs can be made by the owner himself, if they are made in time, and thus considerable expense both in cost of repairs and of labor is avoided.

Overhauling — Every car should be overhauled at least once a year, and even oftener if it gets very severe usage. The best time to overhaul it is at the end of the season, for at that time the owner will know better just what needs attention and what new parts will have to be ordered, etc. It is a good thing to take the motor out of the car, so that one can get at it to better advantage. The motor is the most important part and should receive a very thorough overhauling. It should be cleaned by using kerosene and a stiff brush. All parts should be examined to see what adjustments and new parts are needed. The entire lubricating system should be cleaned and all the old oil and grease disposed of.

The rest of the car should be thoroughly cleaned and all parts inspected to see what in the way of repairing needs to be done. All repairs should be made at once. After the transmission and rear axle have been cleaned, new oil should be added.

Make a thorough job of the overhauling. If the owner does not feel competent to undertake and make a success of it, he should by all means turn it over to a good garage man, for a good overhauling is very essential and the most important thing in the care of a car.

PART II

THE REPAIR OF FARM EQUIPMENT

- I. INTRODUCTION. II. TOOLS ADAPTED TO REPAIR WORK ON THE FARM—WOOD-WORKING TOOLS—TOOLS AND EQUIPMENT FOR WORKING IRON—MISCELLANEOUS TOOLS—HARNESS-REPAIR OUTFIT—SPECIAL CONVENIENCES—COMBINATION TOOL OUTFIT—IRON-WORKING AND SHOP EQUIPMENT. III. SHOP FACILITIES FOR REPAIR WORK. IV. MATERIALS REQUIRED FOR GENERAL REPAIR WORK—WOOD MATERIALS FOR REPAIRING FARM EQUIPMENT—METAL MATERIALS FOR REPAIRING FARM EQUIPMENT—SUPPLIES FOR REPAIR OF HARNESS, CARRIAGE TOPS, ETC.—PAINTS, OILS AND MISCELLANEOUS SUPPLIES. V. SUGGESTIONS.

INTRODUCTION

The successful management of a modern farm depends largely upon the efficiency of the equipment with which the work is performed. The equipment of the average farm can be divided into about three more or less distinct classes, as follows: First, and most important, are the buildings, fences, implements, machinery, wagons, and all appliances used in the more important farming operations; second, utensils and machinery used in connection with the dairy, garden tools, butchering outfit, and the numerous small things for general use about the place; third, the tools, materials, and facilities for keeping the first two classes of equipment in repair and in good working order. It is with the last class that this chapter has to deal, the object being to assist the farmer in the selection of a suitable tool outfit, to suggest a line of supplies that are most commonly required for making repairs, and to give hints regarding the proper care and uses of tools.

In order to secure the greatest efficiency, all implements and machinery should be properly housed when not in actual service, so as to be in good working condition when required for use. Alterations and repairs on buildings and fences are required from time to time to accommodate them to changed conditions and to protect the crops. Farm machinery and equipment generally are subject to wear and breakage, and constant attention to repairs is necessary. The extent to which the repair work should be done on the farm will depend entirely upon local circumstances. If there is a well-equipped shop near-by where the repair work can be done by a trained mechanic without loss of time it may be best to carry the greater part of such work to the shop; but if the shop is at a distance, is poorly equipped, or as is often the case, the mechanic in charge is incapable of turning out good work, it will then be a saving to perform the work at home. Besides, there is a large

amount of repair work that can not be carried to a shop and must be done on the farm if it is done at all.

The Importance of Making Repairs Promptly — Breakdowns are most frequent during the busy season, and much valuable time may be lost in going to some distant shop for repairs or in waiting until a new part of some machine or implement can be secured. In many cases an accident to one of the farm implements will cause the loss of not only a portion of the crop but also the time of a number of farm hands until repairs can be made and work resumed. Permanent repairs can frequently be made at once, and under most circumstances temporary repairs, at least, can be made, provided the necessary tools and supplies are at hand.

The Economy of Making Repairs on the Farm — The question as to how far to undertake to do repair work on the farm will depend considerably upon the personality of the farmer himself and his capability to handle tools and execute the work. The regular work of the farm should be the primary consideration, and any repair or construction work that will cause the neglect of crops should not be undertaken. By the aid of a little training, together with the necessary tools and supplies, the farmer can repair all ordinary injuries to the farm equipment; and as a rule he can do this in a shorter time than would be required to go to a distant shop. If it were not for the economy of time, repairs made in a regular shop and by a trained mechanic would generally be found more satisfactory than those made at home, but the saving in both time and expense renders the repair outfit an important adjunct to the farm equipment.

The Time for Making Repairs — Much of the loss and annoyance from breakage may be avoided by carefully inspecting and mending weak parts of the farm equipment before the rush of the season's work begins. The proper time for making such repairs as may be anticipated is during the winter months and at times when the regular farm work is not pressing. As the season advances the implements that will be required for the next farming operations should be gotten out, gone over, and given any attention required to make them ready for immediate use. If the farm machinery is not properly housed through the winter or during other periods of disuse, then it is all the more important that it should be given a careful overhauling. After inspecting an implement, tightening bolts, strengthening weak parts, and renewing broken pieces, any necessary painting should be done. Frequent applications of dark red metallic paint, consisting either of red lead or Venetian red and raw linseed oil, not only improve the appearance of many of the farm implements but add greatly to their lasting qualities. This is an age when appearances count for much, and a farmer's standing in the community is frequently governed by the appearance of his farm equipment. The man who spends his spare moments in the repair of fences and gates and

in maintaining a neat appearance of the entire farm will easily be a leader among his neighbors.

The Educational Value of the Use of Tools—The use of tools is of great value as an educational feature, especially when the work is carefully performed. The boys on the farm should be encouraged in the use of tools, but should be held responsible both for the care of the tools and the character of the work performed with them. The tool outfit of the farm is of special service on stormy days and will aid greatly in keeping the boys employed and contented to remain at home.

Before beginning any piece of work, a definite plan should be worked out in detail, and if it requires the assembling of several parts each piece should be sketched on paper or on a board, so that when finished a close fitting of parts will be assured. It may be well to add a word of caution regarding the improper use of tools, for constant tinkering will work more harm than good. If a bolt is tight, that is sufficient, and an extra turn with the wrench may strip the threads and cause trouble. The taking apart of machinery should be avoided, except in cases where it is absolutely necessary to do so. The reaper and mower and other machines of this class are securely put together at the factory, and if the parts are removed it is difficult to restore them to their proper adjustments.

It is doubtful whether horseshoeing, wheelwright work, and repair work which requires special machinery can be economically performed on the farm, except where the farming operations are sufficiently extensive to justify the establishment of a shop and the employment of a mechanic.

TOOLS ADAPTED TO REPAIR WORK ON THE FARM

The selection of the tool outfit will depend upon the scope and character of the work to be performed.

On most farms there is a deficiency of suitable repair tools and supplies, and an increased investment along this line is strongly recommended. Some farmers, however, need to be cautioned against hasty, indiscriminate purchases. A small, well selected outfit, used to the best advantage and well cared for, will prove more satisfactory than a large miscellaneous assortment improperly kept and used.

In this chapter no attempt is made to determine the extent of the repair outfit which the individual farmer should purchase or the amount and scope of the work he should undertake. The problem is one for each farmer to solve, as he alone is familiar with all the conditions. The aim here is to furnish information which will be useful to farmers of all classes in selecting repair outfits, whether they be large or small, leaving each farmer to decide the extent to which he should purchase and use the tools and supplies listed.

In nearly all localities most of the tools may be purchased from the local hardware dealer. In many places there are stores known as "farmers'

supply houses" from which many of the more common tools may be purchased. In addition to these, many of the manufacturers of tools offer combination outfits, and the large "mail-order" houses of the country are prepared to supply tools of all kinds, either singly or in combinations. A number of tools and appliances described herein are not ordinarily found in the regular stores, and these can be made either by a local mechanic or on the farm.

Under most circumstances it will pay to secure tools of good quality, although fine exterior finish is not essential. Tools of very inferior quality are offered at low prices, but they invariably prove a disappointment to the purchaser. The name of the manufacturer is a sufficient guaranty of the quality of many tools, and the purchaser is advised to secure only those that are sold under a guarantee from either the manufacturer or the dealer. When contemplating the purchase of a collection of tools, make a careful study to see just what ones are needed, then purchase all at one time, and a liberal discount can generally be secured.

For the convenience of intending purchasers in making up a set of tools, lists with descriptions of those most commonly required on the farm are here given; also suggestive combinations varying in price from \$2.50 to \$25. In describing the tools, they have been divided into classes, including wood-working, iron-working, miscellaneous; and general-purpose tools, and special conveniences for repair work. In making up the lower priced combinations, preference is given to the tools required for the more simple operations and having a broad range of utility.

Wood-Working Tools

In the case of certain tools more than one shape or style is offered by dealers. In a few cases a particular type of tool is better adapted to use on the farm than others, and these differences are mentioned in connection with the following list.

Ax—An ax is perhaps one of the first tools required upon a farm. The ax properly belongs to the regular farm equipment, but inasmuch as an ax which is used for general purposes on the farm is rarely in condition for use in making repairs, it is recommended that at least two axes be on hand, one to be kept in first-class condition and to be used for repair and construction work alone. Axes are of various grades and range in price from 75 cents to \$1.50. Axes also vary in weight between 2 and 5 pounds, 4¼ or 4½ pounds being a good size for general use. It always pays to secure a good ax, and a hand-made hickory handle is to be preferred to the cheaper machine-made ones.

Hand Ax—The tool commonly known as a hand ax is similar to a large hatchet or, rather, is a compromise between a hatchet and a broadax. The blade of the hand ax is ground on one side only, and it is especially adapted for use in hewing the side of a post and for "roughing out" doubletrees, tongues, and similar parts of machinery.

Hatchet—A hatchet is almost indispensable on the farm, even where the tool outfit is very limited. There are several styles and shapes of hatchets on the market, the half hatchet (Fig. 1, B) being perhaps the most serviceable type. There is no tool where quality counts so much as in the hatchet; however, a good one can be secured for about 75 cents.

Handsaws—A good handsaw is almost as important on the farm as an ax or hatchet. A crosscut saw, having regular V-shaped teeth, is most often

required, but a ripping saw will be desirable where a large amount of lengthwise sawing is to be done. The difference in the shape of the teeth of the crosscut and ripping saws is shown in Fig. 2. A crosscut saw for general farm purposes should not be too fine, one having about 8 teeth to the inch being desirable. If more than one saw of this class is kept, the collection should include a No. 7 or No. 8 for the rougher

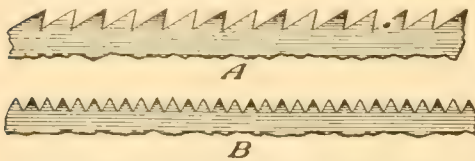

Fig. 2.—Saw teeth: A, ripping saw; B, crosscut saw.

work and a No. 11 for finer cutting. A large-toothed crosscut saw can readily be used in place of a ripping saw, especially if the teeth are filed a trifle on the order of those of the ripping saw.

The proper sharpening of saws is essential, and unless one has had considerable experience it will be desirable to have this work performed by a trained mechanic. The saw-sharpening outfit consists of two thin boards between which the saw blade can be clamped in the vise or workbench clamp, a "set" for use in giving the teeth of the saw the proper spread, and a small three-cornered file. First go over the teeth of the saw with the "set" and open them just enough to give the blade clearance in the wood, being careful to spread the teeth in the same direction as they were originally. After having properly opened the teeth proceed to sharpen them with the small three-cornered file. Hold the file with both hands, at a slight angle with the saw, and draw it about twice through each notch between the teeth. File one side of the saw at a time, skipping every other notch; then reverse the blade and file the other side. It should be the aim to retain the shape and pitch given the teeth in the factory.

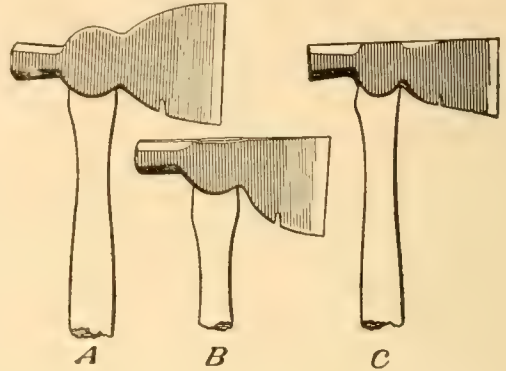

Fig. 1.—Three types of hatchet. The half hatchet (B) is best adapted for general farm use.

Compass Saw—The compass, or bracket, saw is a narrow saw blade tapering to a point. The principal uses of a compass saw are for cutting curved surfaces for the timber parts of implements, sawing circular openings, and sawing a slit from an auger hole in which the regular handsaw may be started.

Steel Square—For most purposes a square having a length of 24 inches on one arm and 16 or 18 inches on the other arm will be found satisfactory. For lighter work a medium-sized square is convenient, and for very small and careful marking the try-square, measuring about 4 by 6 inches, is desirable. The standard-size square will be found most important, and this can be secured at prices ranging from 75 cents to \$1.50, or even higher. A small try-square can be purchased for 25 or 30 cents.

Bevel Square—The bevel square (Fig. 3) is a device one blade of which can be set at any angle to the other. This tool is useful where a number of pieces of material are to be cut to a given slope, the siding for the gable end of a building being a good example. The cost of a bevel square should be about 40 cents.



Fig. 3. Bevel square.

Drawing Knife—The uses of this implement on the farm are too well known and numerous to require mention. The essentials of a serviceable drawing knife are good steel in the blade and substantial handles securely riveted. A first-class drawing knife adapted to general purposes can be secured for about \$1.

Brace and Bits—For boring holes not exceeding $1\frac{1}{4}$ inches in diameter, a brace and a set of bits are essential. There are several types of brace upon the market. The simpler forms can be secured for 40 or 50 cents each, while the more elaborate types with ball bearings and ratchet shank frequently sell as high as \$2.50. For ordinary work the cheaper form of plain brace will answer, but for boring in close quarters a ratchet brace that will work without turning the handle completely around is desirable.

The bits for use in the brace can be secured singly or in sets of 6, 8, or 12, including sizes ranging from one-fourth inch to $1\frac{1}{4}$ inches. A set containing eight bits will answer practically every requirement on the farm. The set containing twelve bits includes sixteenth-inch sizes and can be secured at prices from \$2.50 upward. The brace and a full set of bits should not cost more than \$5.

Gimlet Bits—For boring small holes in wood, especially for the insertion of wood screws, an assortment of gimlet bits is desirable. The uses of the gimlet bits are limited, however, and their place may be filled by the small sizes of twist drills which may be used for boring either wood or metals.

Screw-driver Bit—For setting wood screws in hard wood or for

the removal of old ones there is nothing equal to a square-shank screw-driver that may be used in the brace. This little tool can be made from the shank of a broken carpenter's bit, from an old file, or a small piece of steel, or it can be purchased for 10 cents.

Screw-driver—The common hand screw-driver is especially desirable for use about the dwelling and for light work on machinery. In order that a screw-driver should give good service it is essential that the metal part should consist of good steel and that it should extend through the handle and be securely riveted. The handle should also be protected from splitting by means of bands or rivets. This type of tool can be secured at prices ranging from 25 to 75 cents, according to size and quality.

Augers—For boring holes larger than $1\frac{1}{4}$ inches in diameter it will be necessary to secure regular augers having T-style handles. By having the square shank of the augers of the same size and provided with a thread and nut at the end, one handle can be made to serve for all. There are handles on the market which are provided with an iron plate and thumb-screw for clamping to the auger shank.

If the cutting edges of an auger or a bit become dull, they may be sharpened with a small file. To merely sharpen an auger, file on the lower side of the cutting edges, being careful to keep them of the same pitch or bevel. In case a bit does not take sufficient hold, first see that the threads on the center point are clean; if the difficulty is not with the threads, then file the upper side of the cutting edges a little.

Jack Plane—The name "jack plane" is applied to that class of planes that are suited for general purposes, especially for rough work. The old form of wood-body jack plane with its wedge-set bit has been largely replaced by the more modern iron or combination wood and iron plane, with spring clamp and thread feed to regulate the bit. A very good 14-inch jack plane can be bought for \$1.50.

Smoothing Plane—This tool is similar to the jack plane except that it is smaller and is designed for imparting a smooth finish after the rougher surface has been removed. The cost of a smoothing plane will be about \$1.25.

In grinding the bit of a plane care must be taken to keep the edge square and to prevent the corners from becoming rounded. It is well to have a small square at hand and try the edge from time to time while grinding. After grinding the plane bit always finish on an oilstone, smoothing off any bur or rough edge that has been formed in grinding. Do not grind the plane bit every time it loses its keen edge, but simply whet it on the oilstone; grind it only when the oilstone fails to give a cutting edge. In resetting the bit in its place, first have the cutting edge of the bit a little higher than the lower surface of the plane, then after clamping it in place gradually feed it downward until the proper depth of cut is reached.

Wood Chisels—A number of chisels of sizes from one-half inch to $1\frac{1}{2}$ inches are desirable. The type known as "socket and firmer," with a

leather tip on the wood handle, is the best for general purposes. The price will vary with the size and quality from 25 cents to \$1.50 each. A wooden mallet should be used for driving the chisels.

Claw Hammer—This common type of hammer is desirable for use around the house and outbuildings. The principle of construction gives great leverage for drawing nails. If a spike or long nail is to be drawn, the efficiency of the claw will be greatly increased by placing a rounded block of wood between the hammer and the plank from which the nail is being drawn. A medium-grade claw hammer can be secured for about 50 cents, but one of the highest quality will cost 90 cents to \$1.

Claw Bar—Where a great many large nails are to be drawn or where old buildings are to be torn down, there is nothing superior to a claw bar (Fig. 4). This tool can be made by any blacksmith from a piece of three-fourths or seven-eighths inch steel about $3\frac{1}{2}$ feet in length. One end should be shaped somewhat like the claw of a hammer with a wedge-shaped slit for taking hold of nails. The opposite or handle end may be drawn to a chisel point, and serve as a bar for the prying apart of materials; or if drawn to a sharp point it is very useful for drawing staples. The length of handle and short fulcrum of this tool give a powerful leverage when applied to the pulling of spikes or bolts.



Fig. 4.—Claw bar.

Spokeshave—The spokeshave (Fig. 5), sometimes called a scraper, has been in general use for a long time and is still one of the most useful



Fig. 5.—Spokeshave, or scraper.

tools, especially in the finishing of handles or anything that is shaved from wood. A good one can be purchased for 40 cents.

Wood Rasp—The wood rasp is similar to a coarse file and is used for finishing any piece of wood which requires to be brought to a definite size. A wood rasp is desirable for use in fitting the handles of picks, mattocks, or hoes to their sockets. A 14-inch wood rasp will answer general purposes and should cost about 35 cents.

Folding Rule—Where some measuring device is frequently wanted, a folding rule that can be carried in the pocket will be found very convenient. Folding rules are made in lengths from 1 to 5 feet and can be secured as cheaply as 10 cents each, but one that will prove durable will cost 35 to 40 cents.

Chalk Line—Any hard twisted string will serve as a chalk line. Cord

made especially for this purpose can be secured for 10 or 15 cents a ball. Chalk for use on the line can be purchased for 5 cents a ball, or about 15 cents a pound. A chalk line is especially desirable for securing a straight cut through a plank having irregular edges and in "laying off" a tapering tongue or similar part of farm machinery.

Plumb Rule—A plumb rule is desirable for use in construction work and is also adapted to the setting of posts. A device of this kind (Fig. 6) can be made from a piece of board, a bob, and a string.

Spirit Level—This implement will be found useful for a great many purposes. The most common form of spirit level consists of a bar of wood



Fig. 6.—Plumb rule made from a piece of board

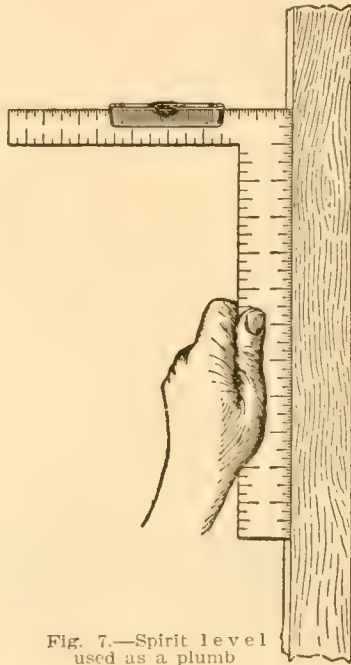

Fig. 7.—Spirit level used as a plumb

with a spirit tube mounted near the center. In the better grades a plumbing tube is inserted near one end. Levels of this kind cost from 40 cents to \$1.50 each. There is a small, or pocket size, level (Fig. 7) that is adapted for fastening on a steel square and may be used either for leveling or plumbing purposes. This form of level can be bought for 15 or 20 cents.

TOOLS AND EQUIPMENT FOR WORKING IRON

The following list, together with short descriptions, includes the majority of the tools that will be required for handling metals in the repair of farm equipment. There are a few tools that are equally useful for working with both wood and metals; for instance, twist drills may be employed for boring almost any kind of material.

Riveting Hammer—A good riveting hammer is essential on every farm where modern machinery is used. There are two types of riveting hammer in general use (Fig. 8), one having one end of wedge shape and the other type (known as a machinist's hammer) having a round end for riveting purposes. The hammer having the wedge-shaped riveting end is generally considered best for farm purposes.

Monkey Wrench—A monkey wrench frequently accompanies one or more of the farm machines, but as this is one of the most important repair tools an extra one will not come amiss. The size of this tool is determined by its length in inches, a 12-inch monkey wrench being adapted for most purposes. The type of wrench having the wood handle in two parts and riveted to the central iron handle is most serviceable. A 12-inch monkey wrench will cost about 60 cents.

Solid or End Wrenches—For many purposes the solid type of

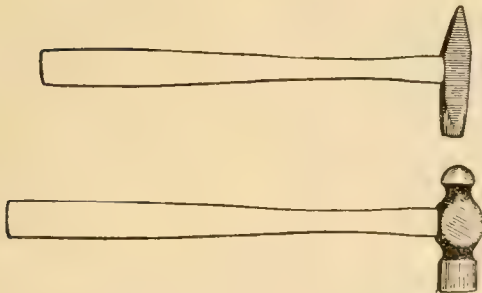

Fig. 8.—Riveting hammers: A, ordinary riveting hammer, B, machinist's hammer.



Fig. 9.—Solid, or S, wrench.

wrench (Fig. 9) with end jaws fitted to the various sizes of bolts and nuts is desirable. Those made somewhat in the shape of the letter S are adapted to working in close places and are not likely to slip. These wrenches may be purchased at prices ranging from 7 to 35 cents each, or they may be made from steel and slightly hardened.

Alligator Wrench—The alligator wrench is very desirable for holding a round-headed bolt or rod of iron; also for turning nuts that are inaccessible for an ordinary wrench. Alligator wrenches having one jaw adjustable are obtainable, but the form having both jaws rigid is somewhat cheaper. The cost of a small alligator wrench will be anywhere between 15 and 60 cents, according to quality and finish.

Pipe Wrench—A pipe wrench of 10-inch or 12-inch size is quite desirable for use in making repairs upon farm machinery. The pipe wrench (Fig. 10) is adapted for turning or holding iron pipe, rods, or bolts. It is essential to have one or more pipe wrenches on farms where a water supply

under pressure and general plumbing appliances are maintained; however, wrenches for pipe fitting should as a rule be somewhat larger than those used for repair work on machinery. The cost of a small pipe wrench suitable for repair work should be about \$1. Neither the pipe wrench nor the alligator wrench should be used extensively for turning the nuts of bolts, as the teeth of these wrenches tear and injure the nuts.



Fig. 10.—Pipe Wrench.

Punches—An assortment of punches, including several sizes and kinds, should be kept on hand. The round, solid-point punch, adapted to such work as punching out the rivets of the ordinary mowing-machine knife, is the most important, although those having square and taper points are frequently required. The collection should include a center punch having a blunt, sharp point for marking metals before drilling.

An assortment of punches may be purchased at a cost of from 10 to 40 cents each, or they may be made from tool steel by a blacksmith.

Cold Chisels—For general-purpose repairing an assortment of various sizes of cold chisels should be kept on hand. These tools belong in the same class as the punches and can either be purchased or made from tool steel. The cost of cold chisels varies according to the amount of steel that they contain, the smaller ones being sold as low as 15 cents and the larger ones from 40 to 60 cents.

A chisel for use in cutting hot iron known as a "hardie" (shown in place on anvil, Fig. 12) is designed to fit the square hole in an anvil, the iron being laid upon the upturned edge of the hardie and struck with a heavy hammer. Another type of cutter fitted with a handle is offered by the trade. In using this tool the iron is placed upon the anvil, the cutter is held in position, and the cutting is done by striking with a sledge or heavy hammer. The cutting edge of any chisel for cutting iron requires to be tempered very carefully in order that it may withstand hard usage.

Files—Both flat and three-cornered files will be required quite frequently in making repairs or improvements to equipment. A large flat file can be secured for 30 or 40 cents, and the small three-cornered ones will cost only 10 or 15 cents each. In securing a large flat file it is desirable that it should not be too fine, one of the flat bastard type being the most serviceable. The three-cornered files can be secured with single or double cutting ends. Square and round, or rat-tail files are useful for many purposes.

Forge—There are numerous makes of portable forges on the market, practically all of which are adapted to use on the farm. This type of forge is desirable where it is necessary to do work in several localities; but where the repair work can all be brought to a central shop, a stationary forge with rotary blower will be found most satisfactory. Portable forges (Fig. 11) can be secured at prices ranging from \$3.50 to \$15, a good outfit being

obtainable for about \$8. A blower with connections for a stationary forge can be bought for \$10 to \$15.

Anvil — Some form of anvil is of as much importance as the forge. Anvils are made in various sizes and are sold by weight. Two types of anvil are offered by dealers, the one consisting entirely of wrought steel and the other of cast iron with a steel facing. The wrought anvil, although more expensive, is to be preferred to the cast-iron type, as there is no danger of its breaking under heavy forging. An anvil suited to repair work should weigh from 70 to 90 pounds. The cost of a cast anvil will be about 3 cents a pound and of the wrought-steel anvil 10 or 11 cents a pound.

Where no regular blacksmith outfit is maintained, a combination vise and anvil will be found fairly satisfactory. The anvil should be mounted

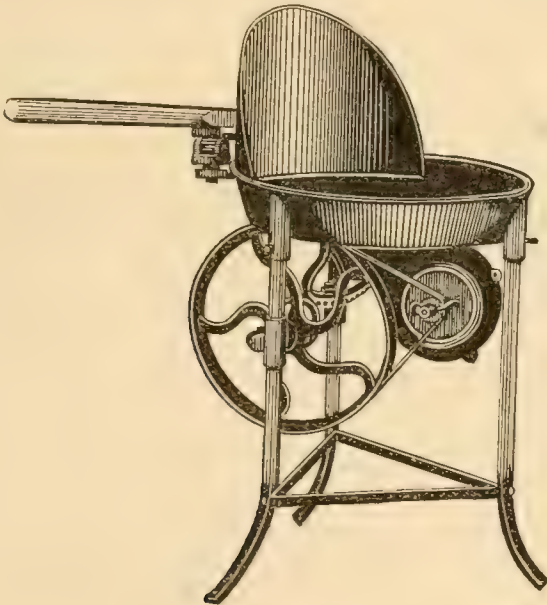

Fig. 11.—Portable forge.

on a heavy block of wood, but in order that it may be moved when necessary it should not be anchored to the floor.

Blacksmiths' Hammers — A forging hammer weighing about 2 pounds will be desirable for working hot iron on the anvil. This tool will cost from 80 cents to \$1.

Where considerable heavy ironwork is to be performed, it will be desirable to secure a sledge hammer weighing about 8 pounds, to be used by the person assisting the blacksmith. This tool is known as a "striking" hammer. The cost of an 8-pound sledge complete with handle will be about \$1.

Tongs — At least two pairs of tongs will be required for blacksmith

work. If more than two pairs are provided the collection should include those having broad, flat jaws, also straight and curved-lip tongs. The size of tongs is determined by their length in inches, the 20-inch length being about right for general purposes. The cost of tongs of this character should not be more than 50 cents a pair.

Vise—Where considerable forging is to be done a regular blacksmith's vise with wrought-steel jaws is desirable. This type of vise will withstand the heavy hammering necessary to the bending and shaping of iron. For general purposes the cast-iron type known as a bench vise will answer, and this can be procured at a much lower cost than the regular steel vise. A combination pipe-holding and bench vise can be obtained, but the cost of such a tool is almost as great as for both a bench vise and a pipe vise when made separately. A very fair bench vise can be secured for \$3.50, a wrought-steel blacksmith's vise will cost about \$5.50, and a pipe vise that will hold all sizes of piping from 2-inch down

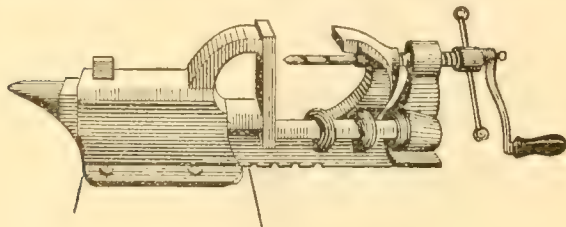

Fig. 12. Combination vise, anvil and drill.

to the smallest can be obtained for \$3.

Combination tools (Fig. 12) intended to do the work required of a vise, anvil, and drill press are upon the market, but the separate tools will

always be found most convenient and durable. A combination tool of this character can be obtained for about \$4.

Drill Press—Where extensive repairs are to be undertaken, there is no part of the repair outfit more desirable than a good drill press. The possession of some device by the use of which bolt and rivet holes may be drilled in metals renders possible the repair of almost any broken part of an implement. There are several forms of drilling machines upon the market, but a standard drill press (Fig. 13) will prove most satisfactory. A machine of this class is suitable for all ordinary purposes and can be secured, exclusive of drills, for about \$10.00. There is a great difference in the quality of drills, but a fairly good set including $\frac{3}{16}$, $\frac{1}{4}$, $\frac{3}{8}$, $\frac{1}{2}$, $\frac{5}{8}$, $\frac{3}{4}$, $\frac{7}{8}$, and 1 inch sizes can be secured for about \$5.00, making the price of the whole outfit \$15.00. A lower priced outfit is obtainable, but the drill press is a machine which with proper care should last a long time, and it pays to secure a good one.

As a rule the drill press is designed for mounting on a solid post preferably a support of the building in which the shop is located. In operating the drill press place a small block of wood upon the bedplate and beneath the metal to be drilled. Before starting to turn the drill see that its point is in the center-punch mark, which indicates the location where the hole is to be drilled, and that everything is both level and solid. The drill should be

turned slowly and fed downward with regularity. Care must be taken when the drill breaks through the metal that the drill itself does not bind and become broken. When drilling holes in pieces of metal that are too short for holding firmly with the hand, a clamp should be used and the piece of metal fastened firmly to the bedplate.

No one except an expert at grinding should attempt to sharpen the drills, as they must be ground to a particular bevel in order to cut properly. It is best to take them to a machine shop from time to time and have them dressed. Certain drills, such as $\frac{1}{4}$, $\frac{3}{8}$, and $\frac{1}{2}$ inch are used more often than the others, and it is desirable to have extra drills in these sizes on hand.

In boring wrought iron or soft steel plenty of good oil should be used upon the drill to prevent its heating. Hard steel should not be drilled, or at least not without first removing the temper. Cast iron, brass, and composition metals can be drilled without the use of oil. Always make an indentation with the center punch before starting to drill a hole; this provides a starting point for the drill and insures getting the hole in the proper place.

Ratchet Drill—The place of a drill press may in a measure be filled by the employment of a ratchet drill (Fig. 14).

This device has the advantage of being portable, and it may also be worked in close quarters where the use of a drill press would not be practicable. In using a ratchet drill as a substitute for the drill press it will be necessary to provide a solid frame for holding it, as shown in Fig. 14. A common boilermaker's ratchet is obtainable for \$4 or \$5, but the square-shank drills for use with it are more expensive than the common round and taper-shank drills used in the drill press. The ratchet-drill outfit is not adapted for boring holes that are below three-eighths inch in size, owing to the liability of breaking the drills.

Chain Drill—A small chain drilling outfit which works in an ordinary carpenter's brace is desirable for light work. This device is especially adapted to the drilling of tire-bolt holes and similar work not exceeding three-eighths of an inch in diameter. An outfit of this kind, as shown in Figure 15, will cost about \$2 exclusive of drills.

Twist Drills—Regular drills for use in boring metals can be secured

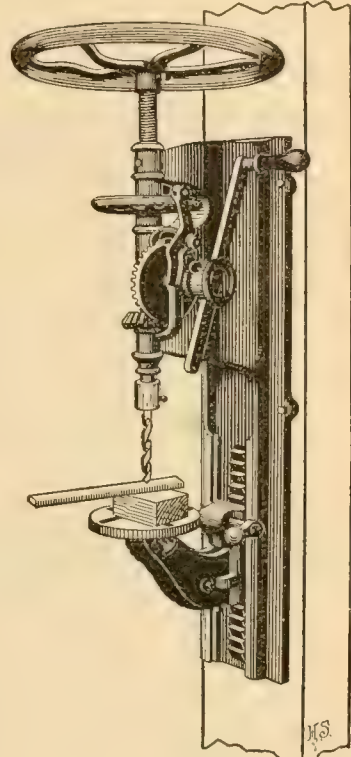

Fig. 13.—Standard drill press.

naving square shanks that fit in an ordinary carpenter's brace. These drills are adapted for boring either wood or metals, and are much more durable for rough work than are the regular wood-boring bits. Twist drills for use in a brace are especially desirable in the smaller sizes. The cost of these drills is from 10 cents upward, according to size and quality.

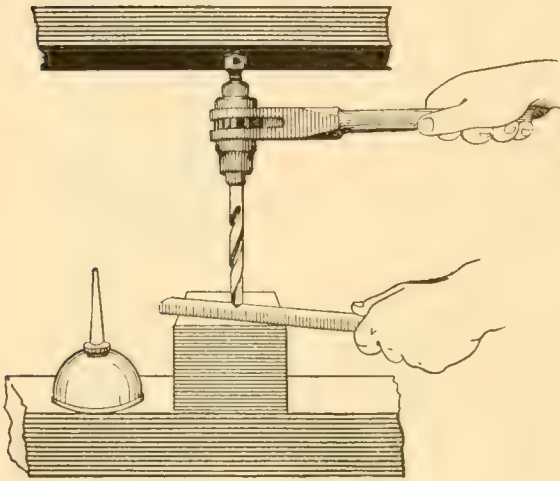

Fig. 14.—Ratchet drill.

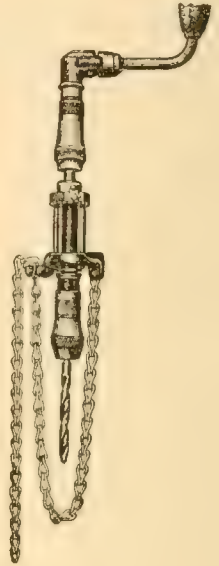

Fig. 15.—Chain drill.

Hack Saw—Under ordinary circumstances a bar or rod of iron can be cut evenly enough with a hammer and cold chisel, but where exactness is required a hack saw (Fig. 16) will be found desirable. As the little blades for cutting iron are very hard and brittle, it is necessary to set them firmly in the frame in order that there can be no chance of bending or buckling. In sawing iron, proceed as in sawing wood, except that slight pressure should be applied in the cutting direction only. The hacksaw should be held firmly with both hands and a uniform movement of about



Fig. 16.—Hack saw. The thread for tightening the blade is located in the handle.

60 strokes a minute maintained. When the blade becomes worn or broken it may be replaced by a new one. The blades cost 8 to 10 cents each, and extra ones should be kept constantly on hand.

Soldering Irons—For general purposes a 1¼-pound soldering iron will be found satisfactory. When continuous work is to be performed two irons are necessary, in order that one may be heating while the other is in use. Soldering irons should be heated only in a clear charcoal fire or in a blue flame of gas, gasoline, or alcohol. Before using a soldering iron it is

essential that the tapering copper point be filed or ground until bright, and then coated with solder by first dipping the brightened hot point into a little of the soldering acid and afterwards rubbing over the solder. This process is known as "tinning" the iron, and is necessary in order to make the solder adhere to the copper and spread evenly. The iron must be retinned as often as the coating burns off. Soldering irons are sold by the pound, the price depending upon the market price of copper; however, the ruling price is about 40 cents a pound.

Thread-Cutting Appliances—A set of stocks, dies, and taps for cutting threads on bolts and inside of nuts is quite desirable. This combination is termed a "screw plate" (Fig. 17) and ordinarily includes all sizes from one-fourth inch to 1 inch. The prices of these tools vary accord-

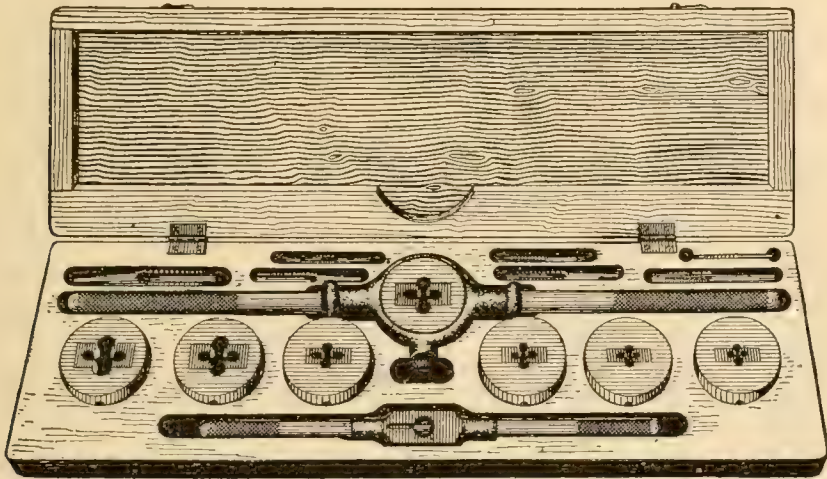

Fig. 17.—Screw plate.

ing to make and number of pieces in the set, but a very good outfit can be secured for \$8 or \$10.

A cheaper device, known as a blacksmith's stock and dies, may be secured for \$2.50 or \$3, but is not as satisfactory as the regular screw plate. In selecting a thread-cutting outfit care should be taken that the pitch of thread corresponds to that used on standard bolts and nuts.

Pipe-Fitting Appliances—With improved water-supply and plumbing fixtures it is possible for farmhouses and adjacent buildings to be equipped with modern conveniences. The work of installing the plumbing fixtures can all be done by the aid of a set of tools adapted to handling pipe and fittings. A set of pipe-fitting tools is essential to the employment of pipes in the installation of modern sanitary fixtures in dairy barns. A complete outfit for cutting, threading and working pipe in sizes varying from one-fourth to 1 inch will cost about \$10 for the simpler kinds of tools, and these answer every requirement. This outfit would include stocks and dies, a pipe

cutter, a pipe vise, and two wrenches. It should be borne in mind that in stating the sizes of pipes the inside, instead of the outside, diameter is given. The thread used on piping is different from that employed on bolts; consequently the dies for one are not adapted to threading the other.

MISCELLANEOUS TOOLS

There are a number of tools adapted to the handling of both wood and metals required in general repair work about the farm.

Tinners' Snips — A small pair of tinners' snips, or shears, is desirable for cutting all kinds of sheet metals that may be required either for repair or construction work. The size of these shears is determined by the length of their jaws in inches. A $2\frac{1}{2}$ or 3 inch size is desirable and should cost between \$1 and \$1.50.

Small Vise — A small bench or table vise having about a $2\frac{1}{2}$ -inch jaw is useful for many purposes, especially where the objects to be held are quite small. This tool is also desirable for mending harness in case a regular harness clamp is not available. A vise of this character will cost all the way from 50 cents to \$1.50, according to size and quality.

Dividers — The little implement known as dividers, or compasses, is desirable for drawing circles or segments of circles in the making of special parts of machinery from wood. The cost of a pair of dividers with a segment and set screw for setting to any angle should not be more than 60 cents.



Fig. 18.—Pliers

Pliers — Some form of pliers for working wire is essential. Besides their use for handling wire a good pair of pliers is desirable for a great many lines of repair work. There are a number of styles of pliers on the market, but one of the simpler types (Fig. 18) will give the greatest amount of service. As a rule a very serviceable pair of pliers can be secured for about 60 cents.

Cutting Nippers — A pair of heavy cutting nippers with circular jaws is useful for many purposes, especially for removing a shoe from the foot of a horse or for trimming the edge of a broken hoof. Where a horseshoeing outfit is maintained, the cutting nippers will be included.

Crowbar or Pinch Bar — A crowbar or pinch bar will be found useful on the farm for prying or moving heavy objects. Where stones are to be removed from the soil a bar of this character is almost indispensable. A bar for general purposes weighing about 20 pounds will cost from \$1 to \$1.50.

Maul, or Beetle — A maul, or beetle, can be hewn from a gnarly piece of hickory or gum. The head portion of the maul should be about 9 inches in length and 6 or 7 inches in diameter. Through the middle of this block a hole about $1\frac{1}{2}$ inches in diameter is bored and a shaved hickory

handle inserted, forming a mallet weighing 16 to 25 pounds. If extra heavy work is to be done, the head can be reenforced by means of iron rings, which are put on while hot and shrunken into place. This tool is desirable for driving heavy stakes and similar work.

Grindstone—The farm repair outfit will not be complete unless some form of grindstone is included. The old type of stone with its wooden shaft, crank, and bearings has largely been replaced by the light-running treadle grindstones. No part of the repair work is so important as the keeping of tools in good order, and proper facilities for sharpening are essential. A good stone, mounted ready for use, will cost about \$3.50.

Oilstone—The oilstone is a necessary adjunct to the grindstone, its use being to put a smooth edge on the tools after grinding. Chisels, the bits of planes, and similar tools require grinding only occasionally, but may be sharpened quite frequently on the oilstone, and a fine cutting edge maintained. Instead of water, use kerosene or any light oil on the oilstone and wipe off clean when through sharpening. Oilstones can be bought at prices from 60 cents to \$1.

Oiler, or Squirt Can—This device is a convenience about the shop, both for oiling machinery and for keeping tools in order. A small oiler is desirable for use in connection with the oil-stone. A can of this character will cost from 10 to 40 cents according to quality. In purchasing an oiler care should be taken to secure one having a folded seam where the bottom is joined to the main portion, as a soldered seam is liable to give out in a short while. It is also essential that the bottom should have plenty of "spring" to force the oil from the spout.

Wire Stretcher—On farms where wire fencing is employed it will be necessary to provide an appliance for stretching lines of wire. For light work, where short runs of single wire are to be handled, one of the hand-lever stretchers will be found most satisfactory. This tool consists of a wood lever about three feet in length, about one-third the distance from one end of which is attached a pair of grips or pliers to hold the wire. The wire is gripped in the holder, the short end of the lever passed around the post, and the power applied to the handle. A stretcher of this type can be purchased for about 75 cents.

Another form of stretcher consists of a wire grip to which is attached a ring through which an ordinary crowbar may be passed to serve as a lever. This type of grip is obtainable for about 50 cents.

Staple Puller—A staple puller is essential to the repair or alteration of wire fencing. An old mower guard will serve for this purpose, but a more satisfactory device may be constructed from a piece of $\frac{3}{4}$ -inch steel rod, about 15 inches in length, by drawing one end to a point, then turning about $1\frac{1}{2}$ inches of this point at a right angle to the main portion. In using this tool the point is driven behind the staple by means of a hammer, then by a prying movement the staple is easily drawn. The handle end of the clawbar (Fig. 4) may be shaped for use in drawing staples.

HARNESS-REPAIR OUTFIT

The tools and facilities required for keeping harness in repair are comparatively simple and inexpensive. Many of the parts of harness, together with convenient supplies with which to make repairs, are now offered at reasonable prices by dealers everywhere. A considerable portion of the repair work on harness can be performed by the aid of tools required for other purposes, but there are a few special devices that are desirable.

Leather Punch — A good leather punch is one of the most desirable implements both for repair work and for making alterations in harness to fit animals of different sizes. A leather punch made somewhat on the order of a pair of pliers and having four or more punching tubes of various sizes is most desirable. It can be secured for about 40 cents.

Rivet Set — A rivet set is especially desirable for use in connection with solid copper or coppered steel rivets. This (Fig. 19) is made of a small piece of tool steel and is provided with a small hole for driving down the washer on the rivet, also a countersink for expanding the end of the rivet.



Fig. 19.
Rivet Set.

Riveting Machines — There are upon the market several kinds of lever devices for use in the insertion of hollow or tubular rivets in leather. These riveting machines are comparatively cheap, but as a rule the hollow rivets do not hold so well as the solid rivets.

Awls — For the repair of driving harness there should be kept on hand one or two awls to be used in making the holes for sewing with a waxed thread. Awls of this character can be purchased for about 10 cents each, including handle.

Harness Clamp — A clamp of some character is desirable for holding parts of harness while repairs are being made upon them. For this purpose a small table vise may be employed or a regular steel or wooden clamp may be purchased. A very serviceable home-made clamp may be constructed from two pieces of wood shaped somewhat like the staves of a barrel; at one end these pieces are dressed off so that they will fit together like the jaws of a vise, and the opposite ends may be hinged together or they may be fastened firmly to the sides of a base block. A short distance from the clamping end a screw, a bolt, a leather strap, or some other simple device may be used to draw the jaws tightly together.

SPECIAL CONVENIENCES

In addition to the outfit of tools obtainable from a hardware dealer, there are a number of special devices that may be made on the farm and which will prove a great assistance in general repair work. Among the more important are the following:

Workbench—A workbench of some kind will probably be the first essential. A good type of workbench is shown in the foreground of Figure 21; also in cross section in Figure 20. For the construction of this bench there will be required four boards seven-eighths inch thick, 12 to 14 inches wide, and about 12 feet in length. The length of the bench, however, will depend upon the size of the shop or other space that may be available for use as a workroom. Two pieces of 2 by 4 inch scantling, each 16 feet long, will be sufficient to construct the framework of the bench. All lumber

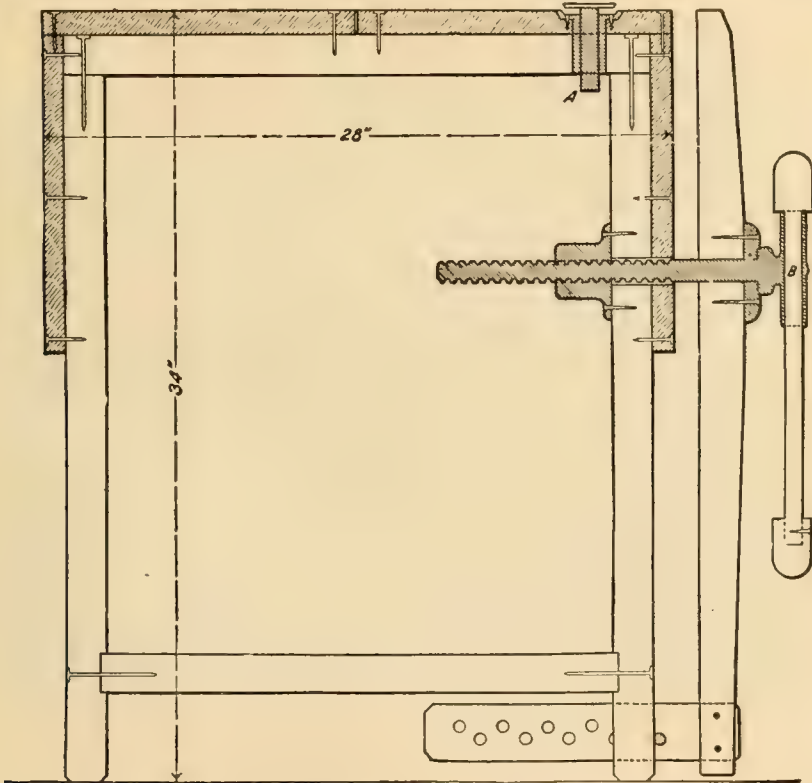

Fig. 20.—Cross section of workbench: A, planing stop; B, bench screw.

entering into the construction of the workbench should be thoroughly seasoned and dressed to uniform width and thickness.

A clamp for holding materials should be constructed from a piece of hardwood and attached by the aid of a carpenter's bench screw, as shown in cross section in Figure 20. This clamp should be provided with notches or pin holes at the lower end, so that it can be set to hold materials of any thickness. Along the front of the bench, two or three holes should be provided, into which pins may be set for supporting boards or other materials that are too long to be held rigid by the clamp alone.

A "stop" for holding materials that are to be planed can be inserted in

the top of the bench, near the left-hand end, as shown in Figure 20. If a regular stop is not employed, its place may be taken by a small piece of notched board nailed on top of the bench.

Sawhorses — A pair of trestles, or sawhorses, each consisting of a piece of 2 by 4 inch or 2 by 6 inch timber, about 4 feet in length, supported upon four legs, as illustrated in the foreground of Figure 21, are very convenient for working upon while marking, sawing, boring, or chiseling. The sawhorses are an accessory to the workbench and should be constructed at the same time. The cost of materials with which to construct both the workbench and sawhorses should not exceed \$5.

Miter Box — Among the accessories to the workbench there is perhaps no device that will give greater satisfaction than a good miter box to be used for sawing small wood materials either square or at an angle. For the construction of a miter box, three pieces of board 1 inch thick, 6 inches wide, and 3 feet in length should be selected and nailed together in the form of a square trough, taking care that the nails are driven well out toward the edge of the boards. Vertical cuts are sawed down through the sides to the bottom board to guide the saw when the box is in use. Near one end a cut is made at right angles with the length of the box to be used in making square cuts. For making bevel cuts for a right-angled miter joint, the sides of the box should be sawed down on oblique lines running at an angle of 45 degrees with the length of the box. Two such cuts should be made and should cross each other at the middle of the box, forming a letter X. In marking the box to make these cuts, the square should be laid flat on top of the box so that its corner is flush with the outer edge on one side, and each arm reaching obliquely across the box will show exactly the same number of inches to the outer edge on the other side. When the square has been correctly placed, mark along one arm for one of the cuts; then reverse the position of the square and mark for the other cut. A miter box is shown on top of the workbench in Figure 21.

COMBINATION TOOL OUTFITS

For the benefit of those contemplating the purchase of tools for use on the farm the following combinations are suggested. In making up these lists of general-purpose repair tools the better grades have been placed in the higher priced sets, although those included in the cheaper outfits should be of good and durable material.

A \$2.50 Outfit — A hatchet, a handsaw, a small square, a screwdriver, and a pair of pliers.

A \$5 Outfit — A hatchet, a 26-inch handsaw, a small steel square, a drawing knife, a brace and four bits ($\frac{1}{4}$, $\frac{1}{2}$, $\frac{3}{4}$, and 1 inch), a pair of pliers, a screw-driver, a cold chisel, a flat file, and a monkey wrench.

A \$10 Outfit — A hatchet, a hand ax, a 26-inch handsaw, a 24-inch steel square, a drawing knife, a brace and six bits ($\frac{1}{4}$, $\frac{3}{8}$, $\frac{1}{2}$, $\frac{5}{8}$, $\frac{3}{4}$, and 1 inch), a pair of pliers, a screw-driver, a cold chisel, a 12-inch flat file.

a monkey wrench, a jack plane, 2 chisels ($\frac{1}{2}$ and 1 inch), a rivet punch, a riveting hammer, a leather punch, and a small oil can.

A \$15 Outfit — An ax with handle, a hand ax, a hatchet, a 26-inch handsaw, a 24-inch steel square, a drawing knife, a brace and six bits ($\frac{1}{4}$, $\frac{3}{8}$, $\frac{1}{2}$, $\frac{5}{8}$, $\frac{3}{4}$, and 1 inch), 3 twist drills ($\frac{3}{16}$, $\frac{1}{4}$, and $\frac{3}{8}$ inch, with square shank to fit in carpenter's brace), a bit gimlet, a screw-driver, a jack plane, a pair of pliers, 2 chisels ($\frac{1}{2}$ and 1 inch), an auger ($1\frac{1}{2}$ inch, with handle), a small vise, a cold chisel, a monkey wrench, a rivet punch, a claw hammer, a riveting hammer, a leather punch, a compass saw, a spirit level, an oil can, a 12-inch flat file, a 12-inch wood rasp, 2 small

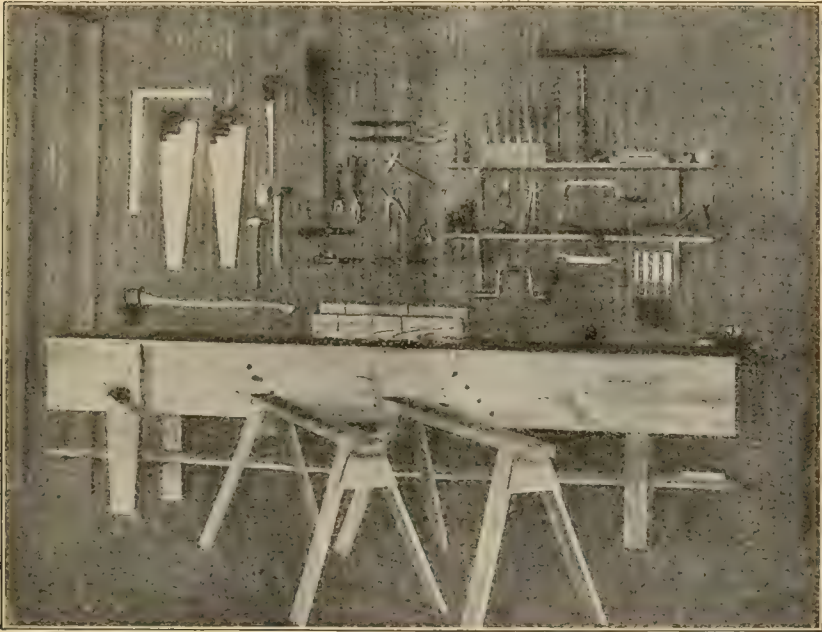

Fig. 21. Interior of workshop with \$25 outfit of tools, a workbench, sawhorses, and mitre box. Courtesy of the United States Department of Agriculture.

three-cornered files, a 2-foot folding rule, a chalk line and a ball of chalk.

A \$20 Outfit — To the list given for the \$15 outfit, add the following: A 26-inch ripping saw, a spokeshave, a bevel square, a scratch gauge, a pair of dividers, a small try-square, a scratch awl, 2 twist drills ($\frac{1}{2}$ and $\frac{5}{8}$ inch), an oilstone, and a pair of soldering irons.

A \$25 Outfit — To the list given for the \$20 outfit add the following: A small steel square, an alligator wrench, a hack saw, a 10-inch pipe wrench, a pair of tinner's shears, a ratchet brace instead of a plain brace, a rivet set, additional bits to make a full set of 12 ($\frac{1}{4}$ inch to $1\frac{1}{4}$ inches by eighths and sixteenths), and a smoothing plane. A \$25 outfit is shown in Fig. 21.

Blacksmithing Tools — A blacksmith's outfit adapted to the requirements of a large farm should include a forge, an anvil, a 2-pound hammer, an 8-pound sledge, a riveting hammer, two pairs of tongs, an assortment of punches, hot and cold chisels, anvil hardie, cutting nippers, coarse files, screw plate, vise, drill press with drills, and a monkey wrench. The cost of this outfit may be as low as \$30 or as high as \$60 and upward, according to the class of materials selected. "Combination outfits" consisting of the above tools are offered at these prices, but if the outfit is made up by selecting from the general stock of a dealer, the price paid will be much greater.

Shop Equipment — The complete equipment of a shop for the making of general farm repairs should include the above blacksmithing outfit, the \$25 collection of wood-working and general-purpose tools, a pipe-working combination, miscellaneous tools, harness-repair outfit, a workbench, a pair of sawhorses, and a grindstone. This entire equipment for a shop can be secured for about \$100 in a fair quality of goods, and for \$150 tools of excellent quality can be obtained.

SHOP FACILITIES FOR REPAIR WORK

A shop or other suitable place where repair work can be carried on during cold or stormy weather is almost as important as the tools and materials with which to make the repairs. A small building devoted exclusively to shop purposes is desirable, but where this is not available a portion of one of the regular farm buildings may be utilized. One side of a wagon shed can frequently be devoted to this purpose. A workbench can be fitted up and provision made for the care of tools and supplies.

Plan of Workshop — A shop which meets the requirements of the general farm is illustrated by the floor plan shown in Figure 22. The shop from which this plan was taken consists of a one-story building about 24 feet in length and 16 feet in width, having a plank floor over about two-thirds of its area, the remainder with an earth floor being used as a blacksmith shop. The floored portion was provided on the one side with a wood-working bench, over which were placed several shelves for the reception of tools. On the opposite side there was provided a heavy plank bench with a vise and other equipment for working iron. Below the iron-working bench there should be provided a rack upon which to store the stock of various sizes of square and round iron required for making repairs. Above the iron-working bench there should be a few shelves for the storage of tools; also numerous pigeonhole boxes for the accommodation of the stock of bolts, nuts, and washers.

This shop was constructed of cheap lumber, the siding being put on up and down with cracks battened, and it has a simple gable roof. By this type of construction ample space is secured overhead for the storage of materials, especially seasoned timber for use in making repairs. An abundance of light is essential to good work, and as much of the repair

work will be done during dark and cloudy weather, the windows should be numerous and so distributed as to provide for uniform lighting. The windows should be protected on the inside by wire netting.

The large doors in the end of the shop are made to cover the entire space between the workbenches, so that the larger farm implements may be brought upon the floor for repairing. Where the climate is cold provision should be made for a heating stove, in order that the shop may be comfortable for work during winter weather. If a portion of a wagon shed or other farm building is set aside for shop work, it should, so far as practicable, be fitted up the same as a regular shop.

The Care of Tools—The system of storing the tools should conform to the needs of those using them and to the work to be performed. In many instances it may be desirable to keep the tools in a portable chest in which they may be carried to any part of the farm or plantation; on the

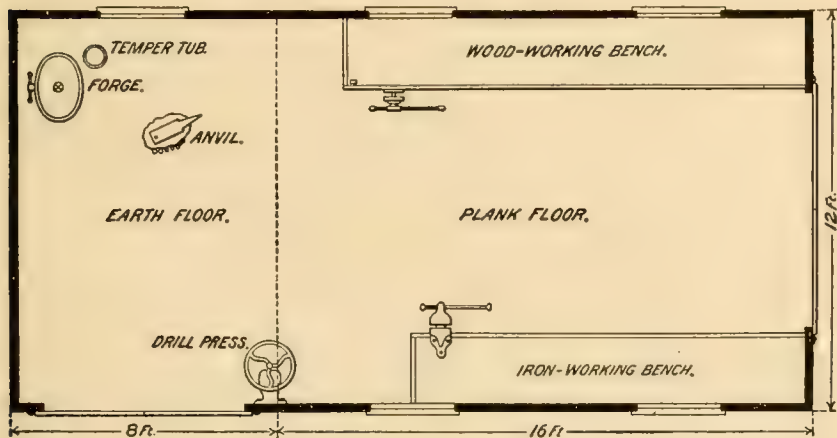

Fig. 22. Floor plan of workshop.

other hand, if the work is done almost entirely at the shop the tools will be more accessible when supported on the walls or upon shelves above the bench.

In climates where the atmosphere is moist the greater part of the time, it is not wise to keep the tools exposed by hanging them on the walls or laying them upon open shelves, but a wall cabinet or a tool chest should be provided. It should be the aim to have a place for every tool, then cultivate the practice of returning it to its proper place immediately upon the completion of the work in hand. A very good plan for keeping the tools in their respective places is to first draw an outline of each tool in its place upon the wall and then paint this space black or some color in contrast with the wall itself, so that when any tool is not in its place its absence will be readily apparent.

Many persons are in the habit of leaving tools where they finish using

them. In the first place, a tool cannot be kept in working condition if allowed to remain exposed to the weather, and in the second place the time lost in locating the tool when it is next required for use will be much greater than that which would be required to return it to the proper place.

MATERIALS REQUIRED FOR GENERAL REPAIR WORK

However complete the tool equipment, it will be of little use without a supply of materials with which to replace worn or broken parts of machinery and implements. The time required to secure stock materials may be as great as that necessary to have the repairs made in the nearest shop. A supply of timber, bar iron, bolts, rivets, screws, etc., should be kept constantly on hand and renewed from time to time as the stock runs low.

WOOD MATERIALS FOR REPAIRING FARM EQUIPMENT

The supply of wood for use in making repairs should be well seasoned and dry. It should include split hickory, ash, and oak, from which handles, singletrees, doubletrees, neck yokes, and similar articles can be made. Split timber is better than sawed for these purposes, owing to the straight grain when the wood is split. Sawed oak, ash, or heart pine, in sizes 1 by 2, 2 by 4, 2 by 6, 3 by 4, 3 by 6, 4 by 4, and 4 by 6 inches, and 14 or 16 feet in length is frequently required for use in replacing broken handles, braces, tongues, axles, etc. It is also desirable to have on hand a small stock of white pine, one-half and seven-eighths inch in thickness, for use in repairing or replacing the lighter wood parts of implements.

A great variety of wooden parts for farm implements is kept in hardware and general supply houses. On large farms it is advisable to keep on hand one or two each of the following: Ax handles, hatchet and hammer handles, hoe and rake handles, fork handles, shovel handles, singletrees and doubletrees, wagon tongues, carriage poles, and buggy and wagon shafts.

It should be the practice to save every small piece of good material and store it in a dry loft or other convenient place. A good piece of a thin board can frequently be saved from a broken packing box, and this will serve as well as new material for repair work. It should be the policy to save every good barrel hoop or extra barrel head for future use in replacing a broken or missing one. Very little time will be required to care for these articles if some system of storing them is employed.

METAL MATERIALS FOR REPAIRING FARM EQUIPMENT

Bar Iron

Where a regular blacksmith outfit is maintained the supplies kept on hand should include a stock of both round and square iron. The bars come in lengths of about 14 feet.

Round Iron Bars—The stock should include the following: $\frac{1}{4}$, $\frac{3}{8}$, $\frac{1}{2}$, $\frac{5}{8}$, and $\frac{3}{4}$ inch, three to five bars each, and one bar 1 inch in diameter. The $\frac{3}{8}$ and $\frac{1}{2}$ inch sizes are most frequently needed.

Rectangular Iron Bars—The stock should include the following sizes: $\frac{1}{8}$ by $\frac{3}{4}$ inch, $\frac{1}{8}$ by 1, $\frac{1}{4}$ by 1, $\frac{1}{4}$ by 2, $\frac{3}{8}$ by 1, $\frac{3}{8}$ by $1\frac{1}{2}$, $\frac{3}{8}$ by 2, $\frac{1}{2}$ by 1, $\frac{1}{2}$ by $1\frac{1}{2}$, $\frac{1}{2}$ by 2, and $\frac{1}{2}$ by 3 inches. The greatest demand will be for $\frac{1}{4}$ by 1 inch, $\frac{3}{8}$ by 2, $\frac{3}{8}$ by $1\frac{1}{2}$, and $\frac{1}{2}$ by 2 inches, and of these sizes three or four bars should be secured. Of the other sizes one or two bars will usually suffice.

T-Bars and Angle Iron—These in sizes up to $2\frac{1}{2}$ inches are very useful for making repairs on harrows, cultivators, and other implements in the construction of which such iron has been used.

The price of bar iron varies with the market, but it is usually less than \$3 per hundredweight.

Iron Bolts

For the convenience of intending purchasers, a list of bolts is given. The sizes most needed in repair work are indicated by the larger numbers suggested. For information concerning prices, dealers or their catalogues should be consulted, as the prices vary with locality and market conditions. Bolts, screws, and rivets can be secured at a great reduction if purchased in original packages containing 50 or 100, or a gross, as the case may be.

Carriage Bolts—As a rule the round-headed or carriage type of bolt is best adapted for use in wood or where wood and iron are bolted together. Whenever a nut is being drawn down upon wood, a washer should be placed beneath it. A hole bored for the insertion of a carriage bolt should not be more than one-sixteenth inch larger than the bolt, as the square shank of the bolt should be driven solidly into the wood to prevent its turning. The difference between machine and carriage bolts is shown in Fig. 23.

The supply of carriage bolts should include the following: 100 each of $\frac{1}{4}$ by 2, $\frac{1}{4}$ by 3, $\frac{1}{4}$ by 4 inches; $\frac{3}{8}$ by 2, $\frac{3}{8}$ by 3, $\frac{3}{8}$ by 4, and $\frac{3}{8}$ by 6 inches; $\frac{1}{2}$ by $1\frac{1}{2}$, $\frac{1}{2}$ by 2, $\frac{1}{2}$ by 4, and $\frac{1}{2}$ by 6 inches. Of the following sizes a dozen each should be secured: $\frac{1}{2}$ by 8, $\frac{1}{2}$ by 10, and $\frac{1}{2}$ by 12 inches.

Machine Bolts—These have square heads but the shanks are round throughout. For bolting together iron parts, they should always be used. The following will make a fair supply for a farm: 100 each of $\frac{3}{8}$ by 2 and $\frac{3}{8}$ by 4 inches; $\frac{1}{2}$ by $1\frac{1}{2}$, $\frac{1}{2}$ by 2, $\frac{1}{2}$ by 3, $\frac{1}{2}$ by 4, and $\frac{1}{2}$ by 6 inches, $\frac{5}{8}$ by 2, $\frac{5}{8}$ by 4 inches. A dozen each of the following should be included: $\frac{1}{2}$ by 8 and $\frac{1}{2}$ by 10 inches; $\frac{5}{8}$ by 6, $\frac{5}{8}$ by 8, and $\frac{5}{8}$ by 10 inches; $\frac{3}{4}$ by 3, $\frac{3}{4}$ by 4, $\frac{3}{4}$ by 5, $\frac{3}{4}$ by 6, $\frac{3}{4}$ by 8, $\frac{3}{4}$ by 10, $\frac{3}{4}$ by 12, and $\frac{3}{4}$ by 14 inches.

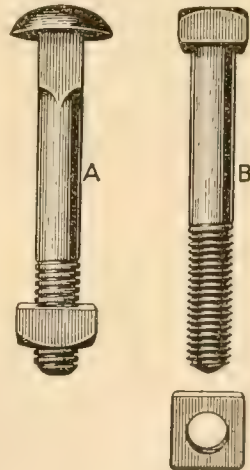

Fig. 23.—Bolts: A, carriage bolt; B, machine bolt.

Tire Bolts — Bolts either $\frac{3}{16}$ or $\frac{1}{4}$ inch in diameter and from $1\frac{1}{2}$ to 2 inches in length are most used. Examine the wheels of the vehicles which are to be kept in repair, and get two or three dozen of each size of bolts needed. A few felly plates should be included.

Extra Nuts — To replace lost nuts, the following should be included in the stock: 25 each of $\frac{1}{4}$, $\frac{3}{8}$, $\frac{1}{2}$, $\frac{5}{8}$, and $\frac{3}{4}$ inch sizes.

Washers — For use with bolts and rivets, get 2 pounds each of the $\frac{1}{4}$ and $\frac{3}{8}$ inch sizes, and 5 pounds each of the $\frac{1}{2}$ and $\frac{3}{4}$ inch sizes.

Rivets, Screws, Nails, Etc.

Iron Rivets — For most purposes rivets with small round heads or with broader flat heads are used. The sizes most needed are $\frac{3}{16}$ and $\frac{1}{4}$ inch in diameter and $\frac{1}{4}$, $\frac{3}{8}$, $\frac{1}{2}$, $\frac{3}{4}$, and 1 inch in length. From a half pound to a pound of each size will be an ample supply. Rivets with countersunk heads are used for some purposes, and a few of the different sizes should be secured; also a few of the special rivets used in repairing mower and reaper knives.

Wood Screws — Screws are classified by number and length, the number referring to the diameter. They are put up in boxes each containing one gross. A gross each of the following sizes should cost about \$2, and will meet all ordinary demands: No. 6, of $\frac{3}{4}$ and 1 inch lengths; No. 8, of 1, $1\frac{1}{4}$, and $1\frac{1}{2}$ inch lengths; No. 10, of $1\frac{1}{4}$, $1\frac{1}{2}$, $1\frac{3}{4}$, and 2 inch lengths; and No. 12, of 2 and $2\frac{1}{2}$ inch lengths.

Nails — Of flat-head wire nails, 5 pounds each of 3, 4, 5, and 6 penny sizes and one keg (100 pounds) each of 8, 10, 20, and 40 penny sizes should be obtained. Nails purchased in small quantities will cost 4 and 5 cents a pound, but if secured by the keg the cost is generally below 3 cents a pound. For certain purposes, such as the laying of floors and the construction of partitions from matched lumber, the square cut steel nails are considered desirable. Wire brads of various sizes and lengths are useful for both repair and construction work, and a few of these of different sizes should be secured.

Staples — Of the standard size used in the construction and repair of wire fencing, 10 pounds or more should be kept on hand; also a pound or two of the smaller sizes for fastening poultry netting. Small staples, known as "double-pointed tacks," are useful for tacking fly screen over windows and for many other purposes.

Strap Hinges, Clips, Wire, Tin, Etc. — On farms that are at a distance from a hardware store, a few pairs of strap hinges of 3, 4, 6, 8, 10, and 12 inch lengths should be kept in stock. Hooks and staples or iron latches for fastening gates and barn doors may also be included in the hardware list. Clips for singletrees, doubletrees, and neck yokes are offered by dealers at prices far below the cost of having them made at a local shop. Other materials that may often prove useful are small copper wire, annealed wire, galvanized wire, hoop iron, galvanized sheet iron, and sheet tin.

SUPPLIES FOR REPAIR OF HARNESS, CARRIAGE TOPS, ETC.

Every farmer should have on hand supplies for the repair of harness, and many will find it an advantage to have also some materials for making the simpler repairs on carriage and buggy tops. Ready made harness and bridle parts of all kinds can be secured from many of the larger establishments.

Harness Rivets—The solid rivets for harness repairs are either of copper or coppered steel, the former costing about three times as much as the latter. They can be bought in boxes containing assorted lengths ranging from one-fourth to three-fourths inch.

Leather—By visiting a regular harness shop, it is often possible to secure at a small cost scraps of harness leather that will prove very useful in making repairs; but where the amount of repairing to be done is large, the purchase of a whole side of good harness leather is advisable.

Harness Hardware—The supplies of this class most often required are buckles of various sizes, snap hooks, bridle bits, hame staples, hame clips, cockeyes, open links, and rings of different sizes.

Other Materials—The outfit should also include thread, beeswax, extra awls and needles, carriage washers, knobs and eyelets for carriage curtains, shaft tips, and harness oil. A broken shaft may often be made good with a metallic shaft end. There are also on the market a number of devices, known as "menders," for making quick temporary repairs to harness.

PAINTS, OILS, AND MISCELLANEOUS SUPPLIES

For repainting the farm equipment the following supplies will be found useful: White lead, red lead, Venetian red, raw linseed oil, and turpentine. Ready-mixed paints can be used, but when made of good materials they are more expensive. For lubrication purposes there should be a supply of machine oil, axle grease, and castor oil. For miscellaneous purposes there will be required small quantities of liquid glue, rubber cement, solder, soldering fluid (prepared by adding metallic zinc to strong hydrochloric or muriatic acid), sandpaper, emery cloth, and twine.

Suggestions—The above lists include many things that will not be required on a large number of farms. Where specialized farming is pursued, only the tools and supplies with which to repair the special farm equipment will be required. The indiscriminate purchase of tools may result in direct loss.

In deciding what tools and materials to purchase, always give preference to those most frequently and urgently needed, passing over those that will be rarely used.

Keeping a machine or vehicle in good repair and well oiled not only increases its efficiency, but lessens the power required in using it.

The proper maintenance of farm machines not only saves money but avoids danger to those who operate them. Keeping the harness and vehicles in repair may prevent a dangerous runaway.

So far as practicable let the repair work be done when regular farm work is not pressing, as on rainy days and during the winter season. Pursue the repair work as a kind of recreation or rest from the regular farm operations.

Do not have several places for the storage of repair tools and supplies. Have one convenient place, and see that all tools are kept there when not in use.

Tools and materials should be kept in their proper places. Do not keep all sizes of bolts or screws mixed together in a single receptacle, but fit up suitable boxes or bins, so that the supplies may be accessible on short notice.

Keep all tools clean and free from rust, and all edge tools sharp.



Fig. 1.

Courtesy of the Minnesota Experiment Station

PART III

ROPE AND ITS USES ON THE FARM

I. INTRODUCTION. II. GENERAL INFORMATION—CONSTRUCTION OF ROPE—SOURCES OF FIBER—STRENGTH OF ROPE—TABLE OF INFORMATION ABOUT THREE-STRAND ROPE. III. PREVENTING THE ENDS OF ROPE FROM UNTWISTING. IV. HITCHES—SHEEP SHANK—HALF HITCH—TIMBER HITCH—WELL PIPE HITCH. V. HALTERS—NON-ADJUSTABLE HALTER—ADJUSTABLE HALTER. VI. SPLICES—SHORT SPLICES—LONG SPLICES.

The ability to tie a few useful knots and splice a rope is of use not only to the sailor, but to the farmer, the construction engineer, and the contractor. Indeed there are times when it is useful to people in nearly all walks of life. In publishing this chapter we hope that it may serve to instruct those who desire to acquire this ability by themselves.

Only a few knots, hitches, and splices are shown, as it is believed that the average person has not the time or persistence to learn a large number of them so thoroughly that he can make them at any time from memory. There are several ways of tying some knots, and more than one way of making some of the splices and hitches, but the author has shown only one way of making each and, so far as he can decide, the way that is easiest to learn, though it may not be the quickest and easiest way used by the expert. To those who may have some word of criti-

cism, the author desires to say that this is not written for the instruction of those who consider themselves proficient in this work. Information regarding other methods and other knots will be gladly received.

GENERAL INFORMATION

Construction of Rope — A rope is made of fibers so intertwined or twisted together as to form a thick cord capable of sustaining a severe strain. The primary object of twisting the fibers together to form a rope is that by friction they may be held together when a strain is applied to the whole. Hard twisting has the further advantage of compacting the fibers and preventing the penetration of moisture.

The steps in manufacturing rope are as follows:

1. The fibers are twisted into yarns in a direction called "right hand," as shown at A in Figure 1.
2. From two to eighty of these yarns are then twisted together into a strand in a direction called "left hand," as shown at B in Figure 1.
3. Three of these strands for a three-strand, and four for a four-strand rope are then twisted together in a direction called "right hand," as shown at C in Figure 1.
4. If these ropes are twisted together to form a cable, they are twisted in a direction called "left hand."

Sources of Fiber — Many different vegetable fibers are used for rope-making. The most common ones are Manila, or Manila hemp, common hemp, sisal hemp, and cotton. Flax, jute, coir fiber, and other materials are also used.

Manila fiber is obtained from the abaca plant which grows only in the Philippine Islands. It obtains its name from the city of Manila from which most of it is exported. The trunk of this plant resembles the banana tree and it is closely wrapped by long leaves which yield fibers from six to twelve, and even eighteen, feet in length.

Common hemp is an annual herb of the nettle family, from four to eight feet high. It has green flowers and a tough, fibrous inner bark. The tough strong fibers obtained from the inner bark are used in making coarse cloth and rope.

Sisal hemp comes principally from Yucatan and Mexico. Its fiber is especially valuable for ship cables as it seems to resist the action of sea water better than most other materials.

Cotton is planted annually in the United States and is the staple agricultural product of our southern states. The commercial cotton is the soft, woolly fibrous material which is attached to the seeds of the cotton plant. The fiber is white or yellow, and from two-thirds of an inch or less to two inches long. The fibers are contained in a three to five-celled capsule or boll which bursts open when ripe and allows the fibers to escape. After the seeds are removed, the fiber is manufactured into thread, cloth, twine, and rope.

Flax is an annual plant with stems about two feet high, blue flowers, and a fibrous inner bark which yields the flax of commerce.

Jute is obtained from two tall, slender-stemmed, annual, Asiatic herbs of the linden family, now naturalized in various countries. The fiber obtained from the inner bark is used in the manufacture of carpets, bagging, canvas mats, and rope.

Coir fiber, which is obtained from the husk of the cocoanut, is an important factor used for rope-making and cordage. It is fairly strong and is lighter than Manila or hemp.

How Sold—Rope is usually retailed by weight, but is ordered by giving the diameter in inches and number of feet wanted. Wholesale dealers sell it by the weight stamped on the coils by the manufacturer, but do not usually break the coils.

Strength of Rope—The strength of a new rope of a given size will depend on (1) the kind of fiber used, (2) the quality of the fiber, (3) the quality of the workmanship, (4) the effect of preservatives on the fibers, and (5) the number of strands. No accurate rule can be given for calculating the strength and any table giving the strength will be only approximately correct. Four-strand ropes have about sixteen per cent more strength than three-strand ropes. Tarring rope decreases the strength by about twenty-five per cent because the high temperature of the tar injures the fibers. The strength of a rope is decreased by age, exposure and wear.

The breaking strength of a rope is the weight or pull that will break it. The safe load is the weight you may put on a rope without danger of breaking it. The safe load must be very much less than the breaking strength, in order that life and property may not be endangered when heavy objects are being moved and lifted. The safe load is usually regarded as one-sixth of the breaking strength. The breaking strength and safe load for old ropes must be largely a matter of good judgment and experience.

Calculation of Strength—For new Manila rope the breaking strength in pounds may be found approximately by the following rule: Square the diameter, measured in inches, and multiply this product by 7,200. Results obtained from this rule may vary as much as fifteen per cent from actual tests. The safe load can be found by dividing the breaking strength by six.

Suppose we wish to find the breaking strength and safe load of a three-fourths-inch Manila rope. The square of $\frac{3}{4}$ is $\frac{9}{16}$, which, multiplied by 7,200, gives 4,050 pounds as its breaking strength, and, 4,050 divided by 6 gives 675 pounds as its safe load.

Hemp rope is approximately three-fourths as strong as Manila, so that we use the following rule for it: The breaking strength of hemp rope in pounds is 5,400 times the square of the diameter in inches. The safe load

is found by dividing the breaking strength by six as we did for the Manila rope. Thus breaking strength for a three-quarter-inch hemp rope would be:

$$\frac{3}{4} \times \frac{3}{4} \times 5400 = 3037.5 \text{ pounds,}$$

and the estimated safe load would be

$$3037.5 \div 6 = 506.25 \text{ pounds.}$$

Calculation of Weight — One rule for calculating the weight of rope is the following: To find the weight of a piece of rope one foot long, square the diameter measured in inches, and multiply this number by 0.32. Results obtained by this rule may vary as much as ten per cent from the actual weight of new rope. Rope will take up moisture if stored in damp places, as basements, so that its weight will be considerably increased.

INFORMATION ABOUT THREE-STRAND UNTARRED ROPE.

Diameter	Circumference	Feet per coil	Weight per coil	Weight per 100 feet	Feet per pound	Breaking Strength		Safe Load	
						Manila	Hemp	Manila	Hemp
In.	In.		Lbs.	Lbs.		Lbs.	Lbs.	Lbs.	Lbs.
$\frac{3}{16}$	$\frac{9}{16}$	2,400	40	$1\frac{5}{8}$	60	240	180	40	30
$\frac{1}{4}$	$\frac{3}{4}$	2,400	55	$2\frac{1}{2}$	43	450	330	75	55
$\frac{5}{16}$	1	2,400	70	3	32	720	540	120	90
$\frac{3}{8}$	$1\frac{1}{8}$	1,200	45	$4\frac{1}{4}$	$23\frac{1}{2}$	1,070	810	180	135
$\frac{1}{2}$	$1\frac{1}{2}$	1,200	90	$7\frac{1}{2}$	$13\frac{1}{2}$	1,800	1,350	300	225
$\frac{5}{8}$	2	1,200	170	$13\frac{1}{2}$	$7\frac{7}{8}$	3,000	2,340	500	390
$\frac{3}{4}$	$2\frac{3}{8}$	1,200	210	17	6	3,900	2,940	650	490
$\frac{7}{8}$	$2\frac{3}{4}$	1,200	295	25	4	5,520	4,140	920	690
1	$3\frac{1}{8}$	1,200	340	30	$3\frac{1}{2}$	6,900	5,160	1,150	860
$1\frac{1}{8}$	$3\frac{1}{2}$	1,200	455	40	$2\frac{1}{2}$	8,850	6,640	1,475	1,100
$1\frac{1}{4}$	$3\frac{7}{8}$	1,200	510	45	$2\frac{1}{4}$	10,800	7,950	1,800	1,325
$1\frac{3}{8}$	$4\frac{1}{4}$	1,200	785	70	$1\frac{1}{2}$	15,000	11,400	2,500	1,900
$1\frac{1}{2}$	$5\frac{1}{2}$	1,200	1,160	100	1	20,640	15,600	3,440	2,600
2	$6\frac{1}{4}$	1,200	1,440	125	$\frac{5}{6}$	24,660	18,600	4,110	3,100

The actual diameter of rope is usually a little larger than the figures given in the table. The circumference is given to the nearest eighth of an inch. The number of feet in a coil may vary from the figures given in the table. Nearly all sizes are now put up in half coils also. The weight per coil will vary with the number of feet and the amount of moisture contained in the rope. The weight of coils of new rope of equal length as received from the factory may vary as much as fifteen per cent from the weights given in the table. The weights given for coils have been obtained by averaging values obtained from various manufacturers' catalogues with the calculated value. The figures giving the weights of one hundred feet and the number of feet in one pound have been obtained by averaging values obtained from manufacturers' catalogues. The actual weights and lengths may vary as much as ten per cent, due to differences in hardness of twist and moisture content.

PREVENTING THE ENDS OF ROPE FROM UNTWISTING

Whipping — Whipping should be used wherever the end of the rope

must pass through small opening, as in reeving a set of blocks. In whipping, carefully observe these directions:

1. Put a string under a strand of the rope at a distance from the end which is equal to a turn of one strand, as shown in Figure 2, and allow several inches of end, as shown at A in Figure 2.

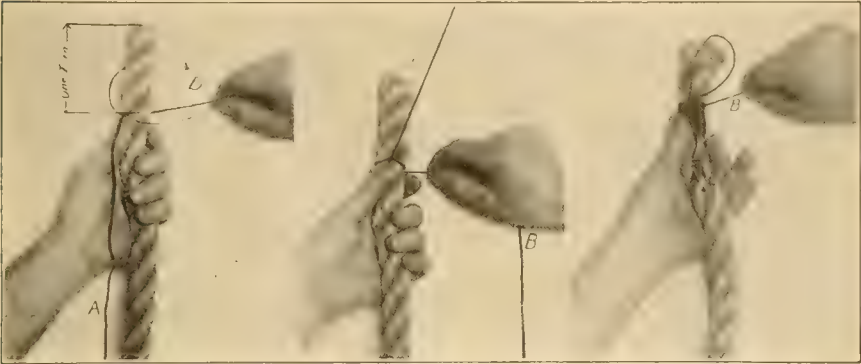

Fig. 2.

Fig. 3.

Fig. 4.

Courtesy of the Minnesota Experiment Station

2. Give the end B one turn around the rope as shown by the arrow in Figure 2, and then fold the end A over as shown in Figure 3.

3. Continue whipping or wrapping the end B tightly around the rope and end A until you have reached a point about midway between the starting point and the end of the rope as shown in Figure 4.

4. Fold the end A back, making a loop that will reach slightly beyond the end of the rope as shown in Figure 4.

5. Continue whipping the end B around the rope outside the loop which should be laid in the groove formed by two strands, until the work appears as shown in Figure 5.

6. Pass the end B through the loop, then pull end A until it draws the end B under the whipping as far as possible, and cut both ends off very close.

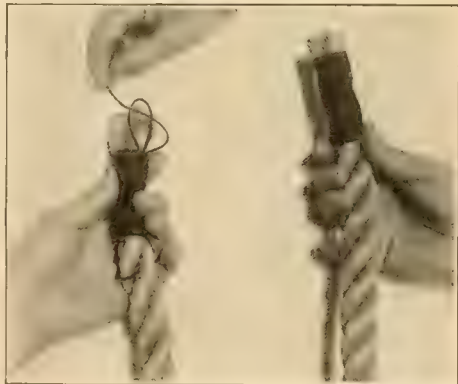

Fig. 5.

Fig. 6.

Courtesy of the Minnesota Experiment Station

The completed work should appear as shown in Figure 6.

Spliced Crown—The spliced crown is a good method for finishing the ends of halter and other ropes where a slight enlargement of the

end is not objectionable. It makes the end of the rope more rigid than do the knots. Learn to make the short splice, then you can more readily follow these directions for making the spliced crown.

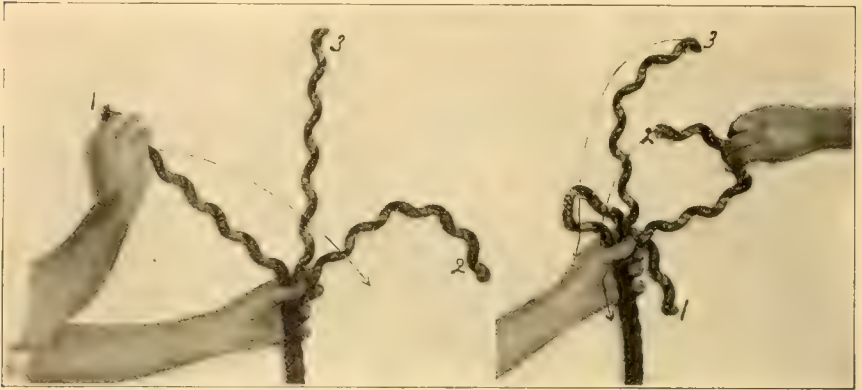

Fig. 7.

Fig. 8.

Courtesy of the Minnesota Experiment Station

1. Unlay the strands about five turns, spread the strands out as in starting the wall knot, and hold the end as shown in Figure 7.

2. Move the end of strand 1 as shown by the arrow in Figure 7, passing it between strands 2 and 3, forming a loop as shown in Figure 8.



Fig. 9. •

Fig. 10.

Fig. 11.

Courtesy of the Minnesota Experiment Station

3. Move the end of strand 2 as shown by the arrow in Figure 8, passing it between the loop and strand 3, drawing it down into the position shown in Figure 9.

4. Move the end of strand 3 as shown by the arrow in Figure 8, passing it through the loop as shown in Figure 9. Be sure that the loop

stands up straight as shown in Figures 8 and 9 when the end of strand 3 is passed through it.

5. Draw the three strands down tight by holding the end of the rope firmly in one hand and pulling each strand alternately with the other hand, as shown in Figure 10.

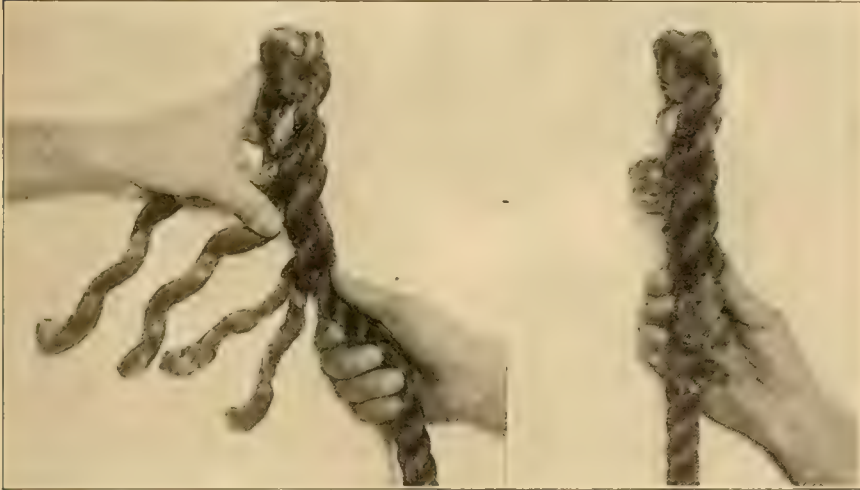

Fig. 12.

Fig. 13.

Courtesy of the Minnesota Experiment Station

6. Splice the three strands into the rope, starting each strand with the aid of a marline spike, as shown in Figure 11. The remainder of the splicing and the finishing is done exactly as in making the short splice. Figure 12 shows the splicing partly completed, and Figure 13 shows the finished work.

HITCHES

Sheep Shank—The sheep shank is used for shortening a rope temporarily. It is made in the following manner:

1. Grasp the rope as shown in Figure 14.
2. Make a half hitch around the loop A as shown in Figure 15 by moving the right hand as shown by the arrow in Figure 14.
3. Grasp loop B with the left hand and half hitch the long part of the rope around the loop as shown in Figure 16.
4. Pull on the long ends of the rope, and the completed sheep shank should appear as shown in Figure 17. It may be made more secure by passing the long ends through the loops or by fastening the loops to the main parts.

Half Hitch—In Figure 18 the short end of the rope is half hitched around the other part.

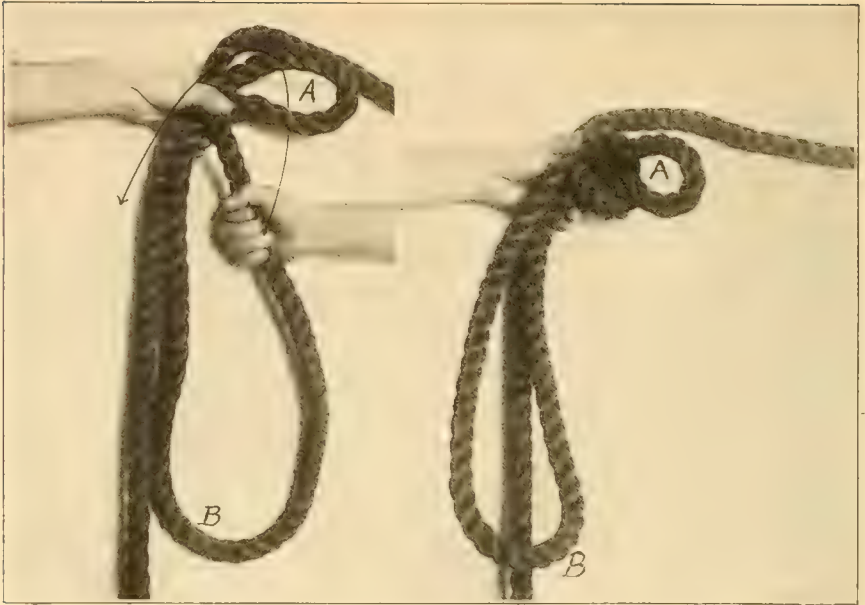

Fig. 14.

Fig. 15.

Courtesy of the Minnesota Experiment Station

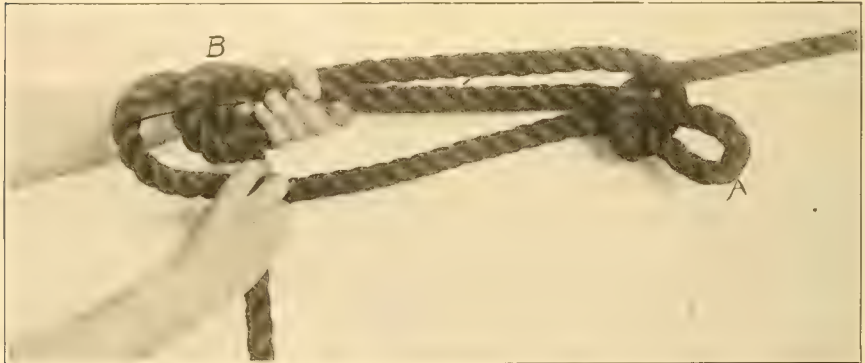

Fig. 16.

Courtesy of the Minnesota Experiment Station



Fig. 17.

Courtesy of the Minnesota Experiment Station

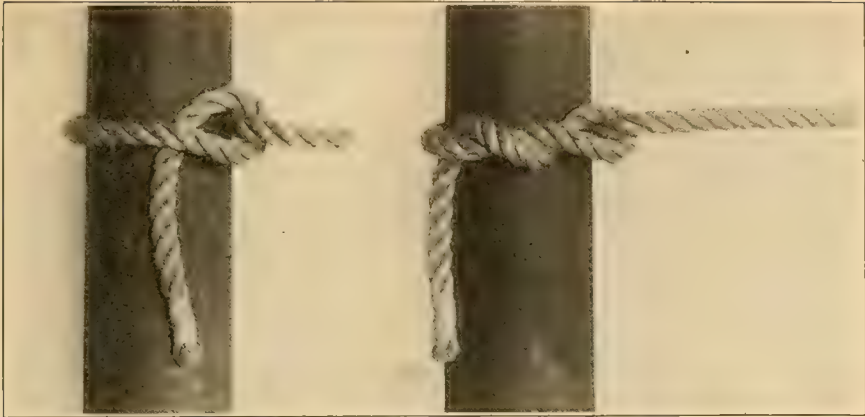

Fig. 18.

Fig. 19.

Courtesy of the Minnesota Experiment Station

Timber Hitch — The timber hitch is used for dragging and lifting logs and timbers, and is shown in Figure 19. To make it take a half hitch and then give the short end one turn around the rope.

Two Half Hitches — Two half hitches constitute a useful fastening for dragging and lifting timbers and for fastening guy ropes. Figure

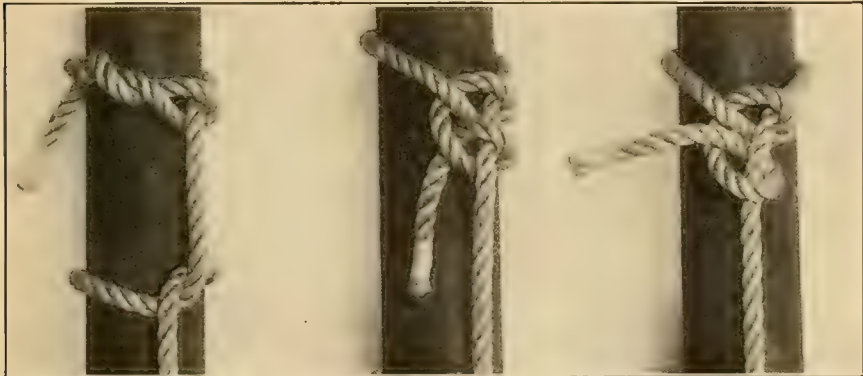

Fig. 20.

Fig. 21.

Fig. 22.

Courtesy of the Minnesota Experiment Station

21 shows the two half hitches made correctly and Figure 20 shows the incorrect way of making them.

Timber Hitch and Half Hitch — A timber hitch and half hitch combined make a more secure fastening than either the timber hitch or half hitch used separately, and are used for similar purposes. The combination is shown in Figure 20. Make the half hitch first and then the timber hitch.

Well Pipe Hitches — Well pipe hitches are used to pull a well pipe or lift a similar object, and are made in two ways.

First Method — 1. Give the rope four turns around the pipe as shown in Figure 23.

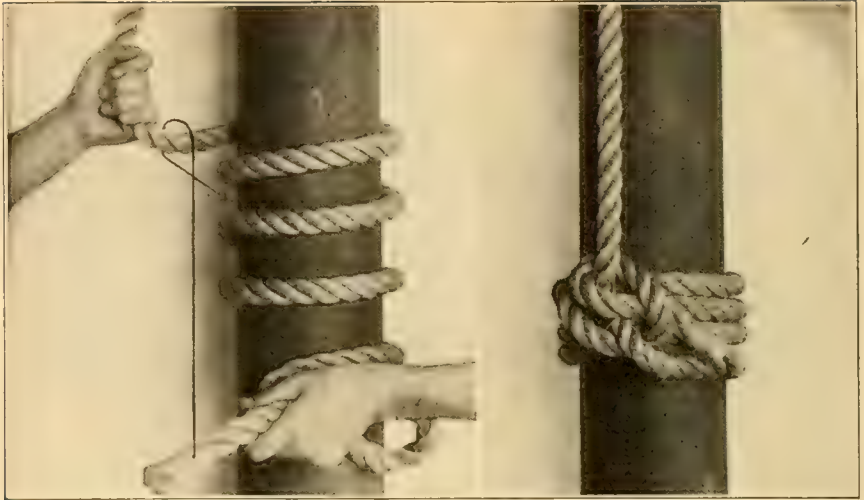

Fig. 23.

Fig. 24.

Courtesy of the Minnesota Experiment Station

2. Give the short end of the rope two half hitches around the long end, making the first half hitch as shown by the arrow in Figure 23, and the second one between the first one and the left hand.

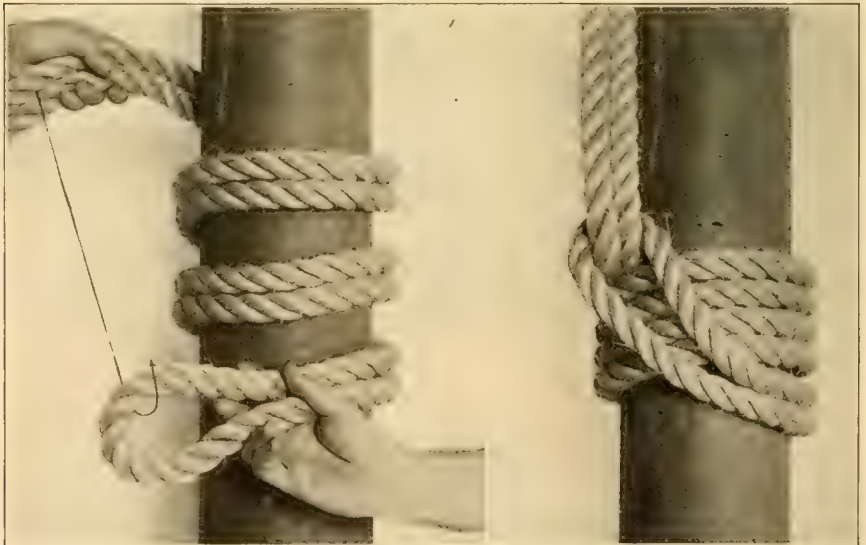

Fig. 25.

Fig. 26.

Courtesy of the Minnesota Experiment Station

3. Slide the turns and hitches tight together as shown in Figure 24 and pull on the long end.

Second Method—1. Give the double part of a rope three turns around the pipe as shown in Figure 25.

2. Pass the loose ends through the loop and draw up tight as shown in Figure 26.

3. Pull on either end or both ends.

HALTERS

Non-Adjustable Halter — The non-adjustable halter is especially adapted to horses and hornless cattle.

Animal	Diameter of rope	Total length of rope	Distance (Figure 27)				Length left for lead
			A to B	B to D	D to E	E to C	
Large horse.....	In. $\frac{5}{8}$	Ft. 15	In. 7	In. 44	In. 19	In. 18	Ft. $6\frac{1}{2}$
Medium horse.....	$\frac{1}{2}$	14	6	40	17	16	$6\frac{1}{2}$
Small horse.....	$\frac{3}{8}$	13	6	36	16	14	6
Large cattle.....	$\frac{1}{2}$	$12\frac{1}{2}$	6	34	14	15	6
Medium cattle.....	$\frac{3}{8}$	12	5	32	12	13	6
Sheep and calves.....	$\frac{1}{4}$	8	4	18	8	8	4

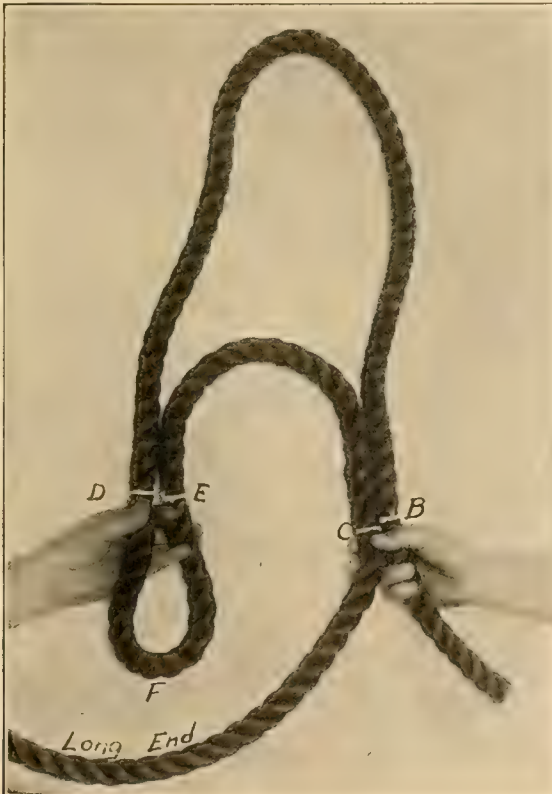

Fig. 27.

Learn how to make short splice before attempting to make halters.

1. Take a total length of rope as given in the above table and measure off the distances AB, BD, DE, and EC as given in the table, marking the points by tying strings tightly around the rope as shown in Figure 27.

After learning how to make halters, the best way is to make the parts the proper length to fit the animal and not use the table.

2. Double the rope at point F so as to bring points D and E together.

3. Pass the end A up through the rope between F and E as shown in Figure 28, making a loop at F a little larger than the rope.

4. Pass the end A back through the rope under the second or third strand from the one it first passed under as shown by the arrow in Figure 28 and draw it up as shown in Figure 29.

5. Remove the string at D and pass the long end of the rope through

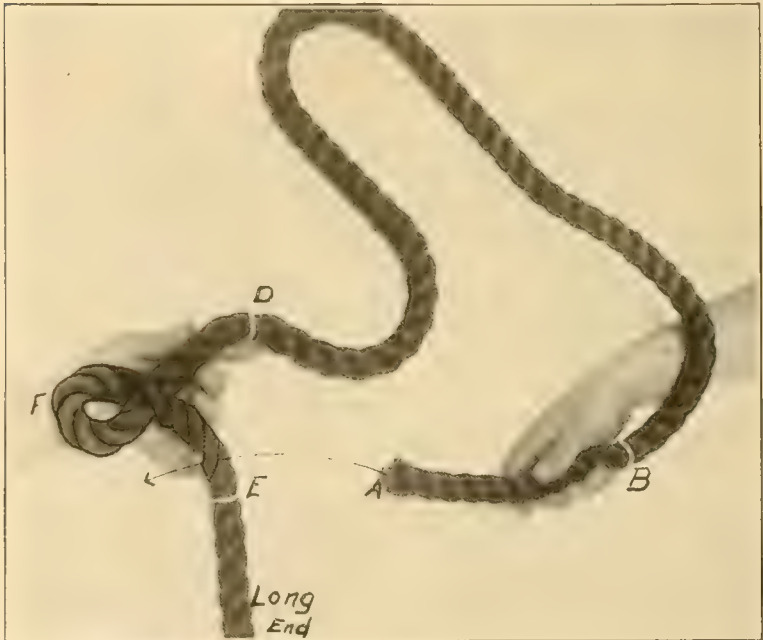

Fig. 28.

Courtesy of the Minnesota Experiment Station

the rope at this point, when it will appear as it does in Figure 30.

6. Draw up tight so that point E looks as it does in Figure 34.

7. Unlay the strands from A to B but leave the string out at B.

8. Give the rope between points B and D two or three turns or reverse twists as shown by the arrow in Figure 31, before passing the ends A-1, A-2, A-3 through the rope at point C. These reverse twists will leave the halter in better shape when it is finished.

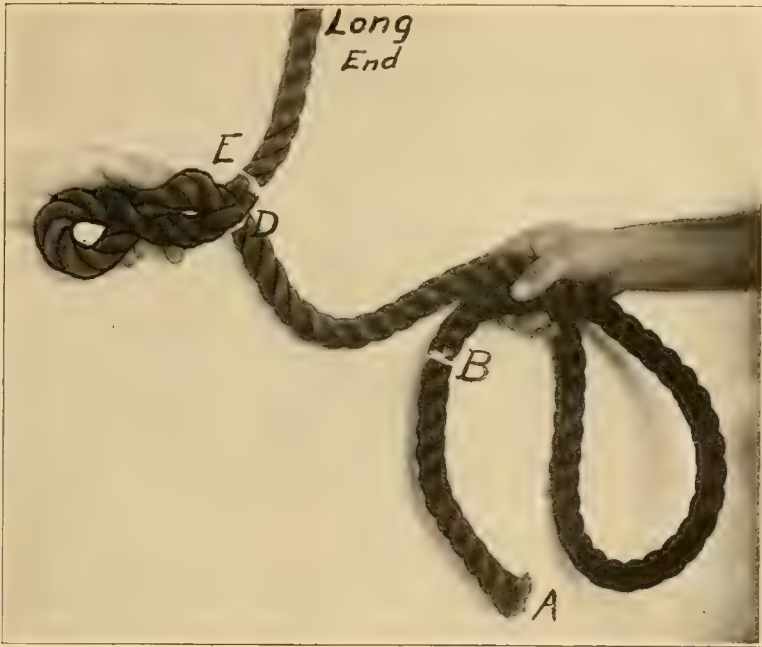

Fig. 29.

Courtesy of the Minnesota Experiment Station

9. Remove the string at point C and pass the three strands through the rope as shown in Figure 31. Have the middle strand at the point where the string was.

10. Draw the three strands up tight as shown in Figure 32. Wrap strand A-1 around strand X, strand A-3 around strand Z, and double back

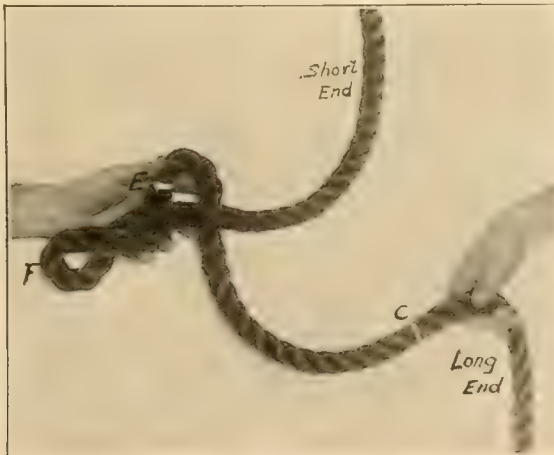

Fig. 30.

Courtesy of the Minnesota Experiment Station

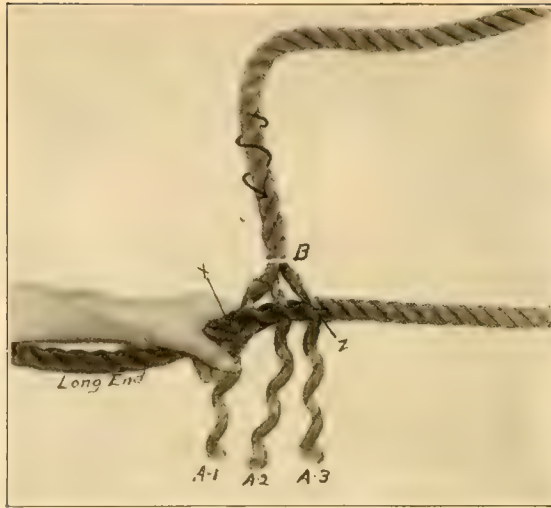

Fig. 31.

Courtesy of the Minnesota Experiment Station

strand A-2 and wrap it around strand Y as shown in Figures 32 and 33, having the direction of the twist the same as shown in Figure 47 for making the short splice. Then these strands out as shown in Figure 49 for finishing the short splice.

11. Pass the long end through the loop as shown at F in Figure 34.

12. Pass the long end up through the nose piece and tie around the double part as shown in Figures 35, 36 and 37.

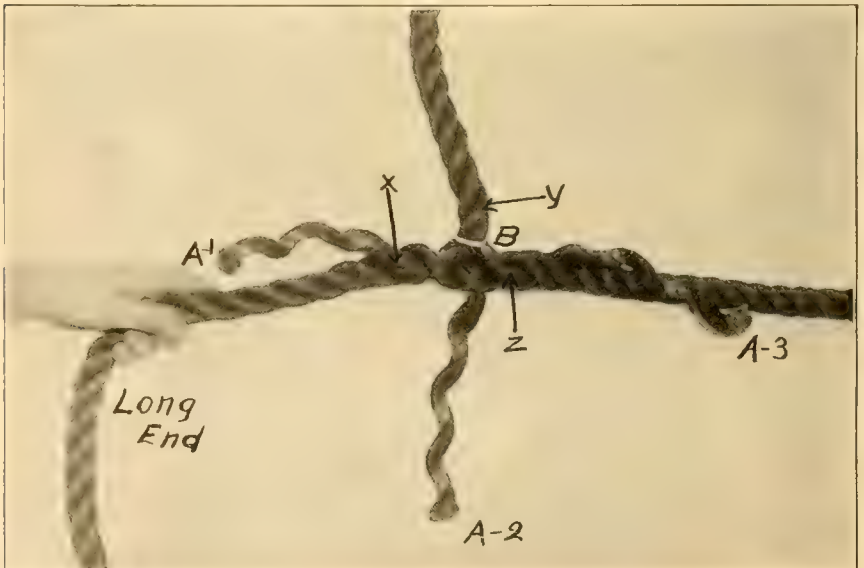

Fig. 32.

Courtesy of the Minnesota Experiment Station

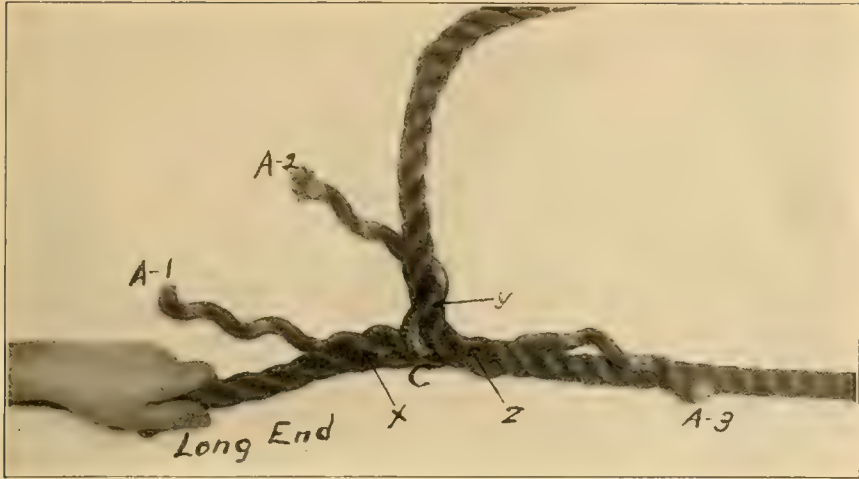

Fig. 33.

Courtesy of the Minnesota Experiment Station

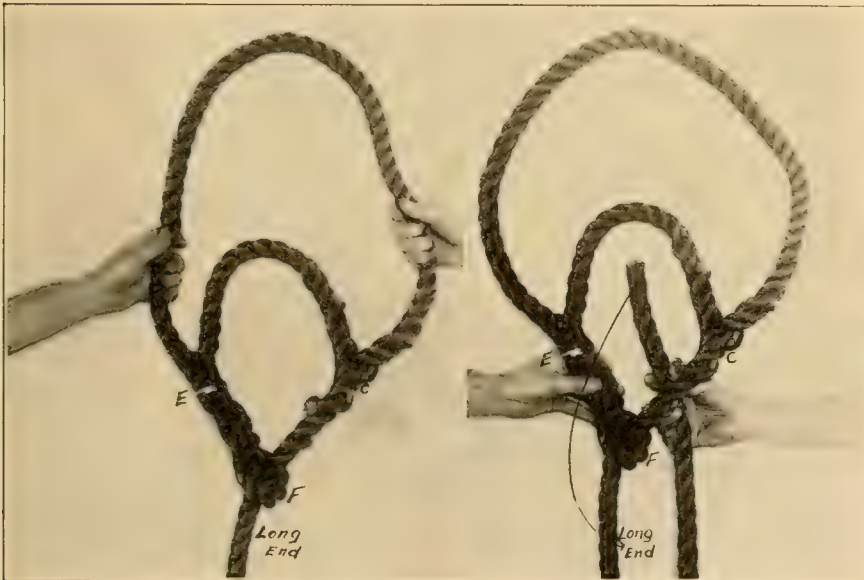

Fig. 34.

Courtesy of the Minnesota Experiment Station

Fig. 35.

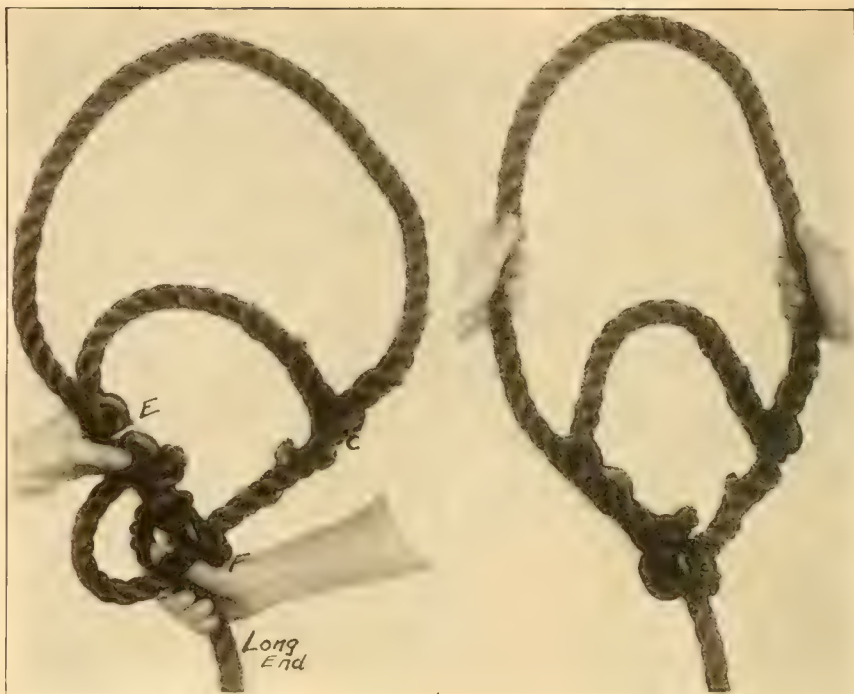

Fig. 36.

Fig. 37.

Courtesy of the Minnesota Experiment Station

Adjustable Halter—The adjustable halter is used for all kinds of stock but is especially adapted to horned cattle.

Animal	Diameter	Total length	Distance from A to B	Length left for lead
	In.	Ft.	In.	Ft.
Large cattle.....	$\frac{1}{2}$	12	18	6
Medium cattle.....	$\frac{3}{8}$	$11\frac{1}{2}$	16	6
Small cattle.....	$\frac{3}{8}$	11	14	6
Calves and sheep.....	$\frac{1}{4}$	$7\frac{1}{4}$	10	4

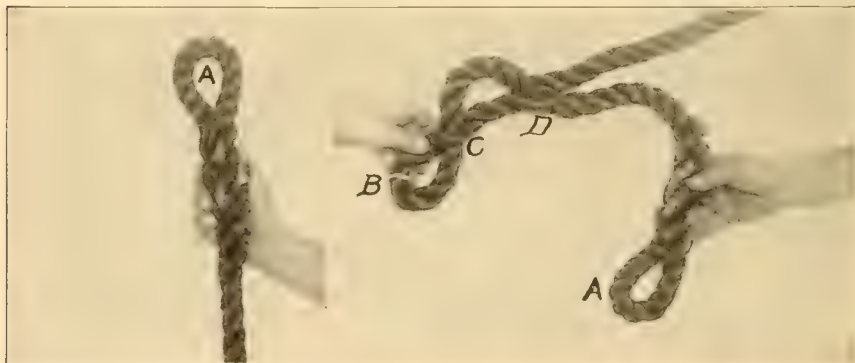

Fig. 38.

Fig. 39.

Courtesy of the Minnesota Experiment Station

1. Take the total length of rope as given in the table.
2. Make a spliced eye a little larger than the rope like the one shown completed at A in Figure 38.
3. Measure off from the center of the eye A the distance given in the table and tie a string tightly around the rope at this point as shown

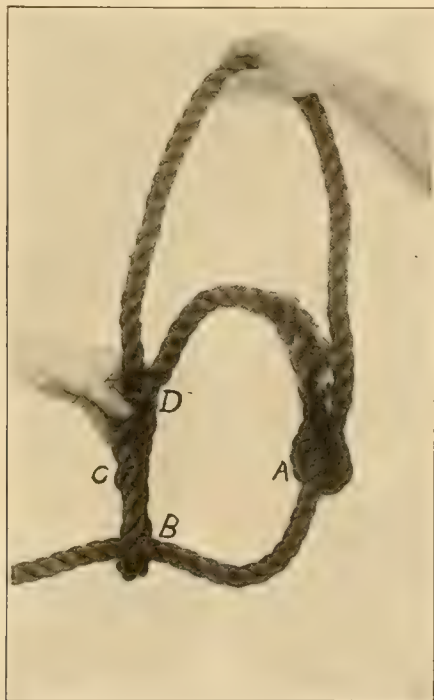

Fig. 40.

Courtesy of the Minnesota Experiment Station

at B in Figure 39. After learning how to make halters, the best way is to make the parts the proper length to fit the animal and not use the tables.

4. Pass the eye A through the rope between B and the other end as shown at points C and D in Figure 39, making the loop at B about the size of the eye A.

5. Pass the end of the long part through the eye A and the loop B as shown in Figure 40.

6. Adjust the halter to the animal, and then it may be secured if desired by tying as shown in Figures 35 to 37.

The length of the nose piece from A to D may be changed by changing the size of the loop at B. With this halter the lead rope may be brought to the side of the animal's head by making the distance from B to D very short.

SPLICES

Short Splices — The short splice is used to fasten two pieces of rope together securely, but should not be used where the splice must run over sheaves or pulleys. In making the short splice with three-strand rope observe the following directions:

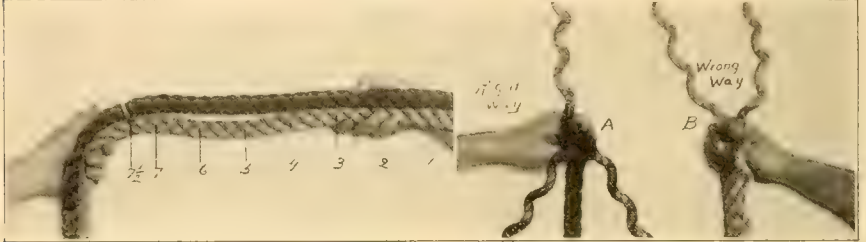

Fig. 41.

Fig. 42.

Courtesy of the Minnesota Experiment Station

1. Count off seven and a half turns from the ends to be spliced and tie strings around the ropes at the points thus found, as shown in Figure 41.

2. Unlay the ends back to the strings and open each end as shown at A in Figure 42. The end shown at B, Figure 42, is not opened in the

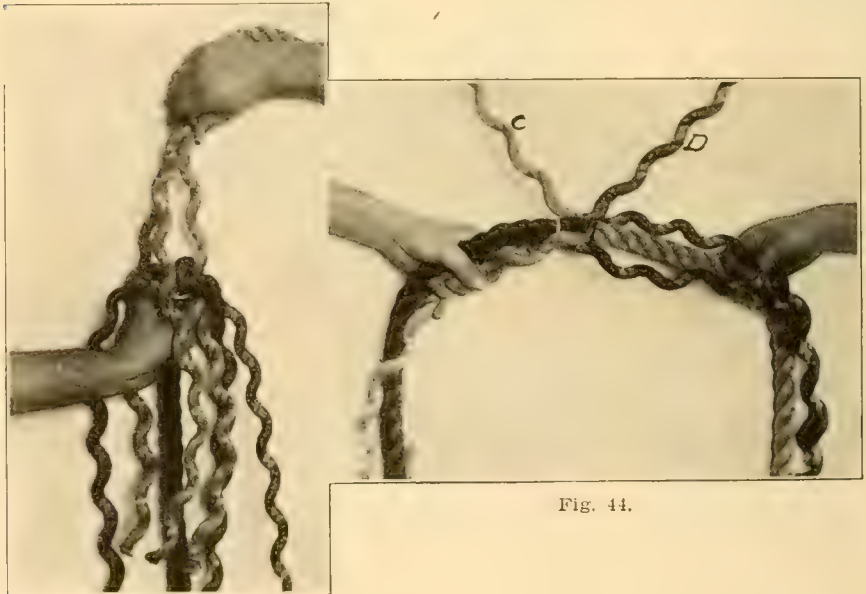

Fig. 44.

Fig. 43.

Courtesy of the Minnesota Experiment Station

right way. No strand should pass between the other two. Be sure to have both ends opened as the one at A, for if you do not, the splice will never be correct.

3. Put the two ends together as shown in Figures 43 and 44, being sure to have a strand from one end between two strands from the other end. We now have three pairs of strands, C and D, forming one pair. Have the strand D from the left hand rope between yourself and C as shown in Figure 44.

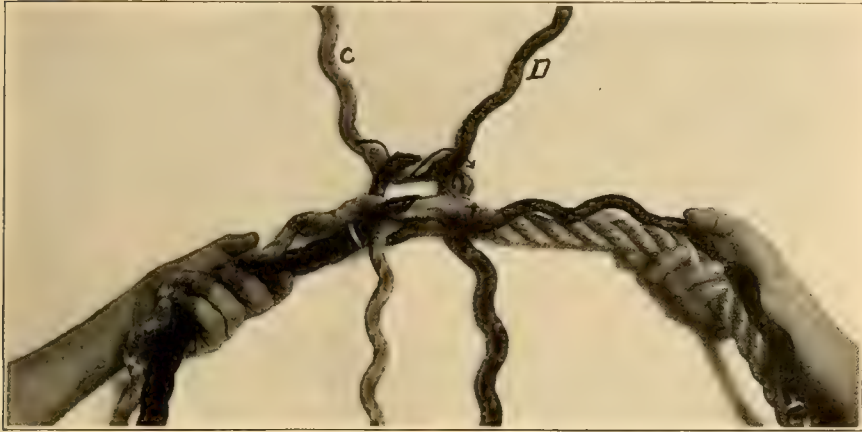

Fig. 45.

Courtesy of the Minnesota Experiment Station

4. Start the twisting of the strands by tying each pair together with overhand knots, having the direction of twist in the knot the same as the direction of twist in the strands, as shown by the arrow in Figure 45.

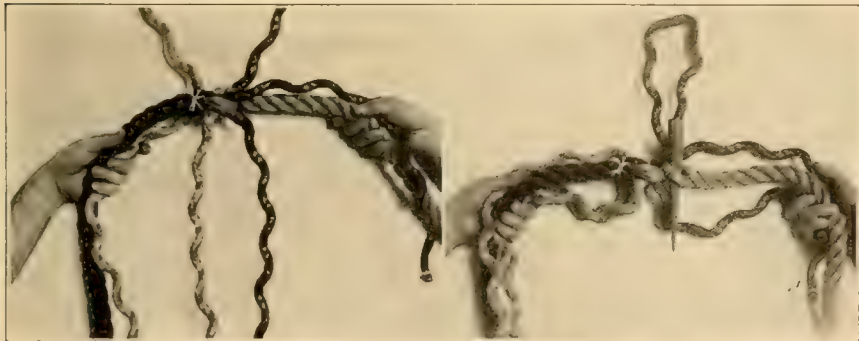

Fig. 46.

Fig. 47.

Courtesy of the Minnesota Experiment Station

5. Draw the three knots up tight by drawing each one up a little in turn, until they appear as shown in Figure 46.

6. Remove the string from the right hand end of the knots and continue the twisting with the aid of a marline spike as shown in Figure 47,

giving one strand two turns, one strand three turns, and one strand four turns about the strands they are tied around.

A marline spike is a piece of wood of the shape shown in Figure 47



Fig. 48.

Fig. 49.

Courtesy of the Minnesota Experiment Station

and is used to separate the strands in splicing rope. This one has a hole in the end in which the strand of rope may be placed with ease when the ends are whipped as shown at N in Figure 47.

Be sure you continue the twisting in the same direction as it has been started in tying the knots. Keep the same pair of strands together all the time and twist the strand you are working with up tight every time it is put around the other as this is the only way to get a firm, compact splice. Try to have the slope of the twist in each pair of strands the same as the slope of the twist in the yarns that make up the strand as this will make a smoother splice. It is better to work with three pairs at the same time rather than to complete the twisting of each pair separately.



Fig. 50.

Courtesy of the Minnesota Experiment Station

7. Divide the strand that has been given two turns into two nearly equal parts as shown at E in Figure 48, and continue splicing with one part, giving it about three turns more.

8. Divide each of the other strands in the same way and give one part of each about three turns more. There should now be six half strands ending at different points along the splice as shown at 1, 2, 3, 4, 5

and 6 in Figure 49. The strands are divided to make the splice taper out gradually.

9. Remove the other string and finish that end of the splice in exactly the same way.

10. Finish the splice by cutting off the loose ends a short distance from the rope as shown in Figure 50. If you cut the ends off close, they

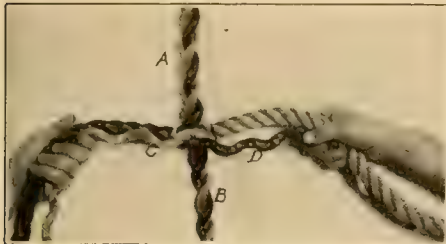

Fig. 51.

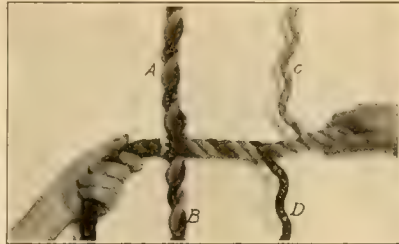

Fig. 52.

Courtesy of the Minnesota Experiment Station

are apt to work loose. If your work has been done properly, you should be able to untwist the splice at any point, and it should show three separate strands, each one being twice the size of the original strands at the center of the splice.

Long Splices — Long splices are used to fasten two pieces of rope together securely and are especially adapted to ropes that must run over

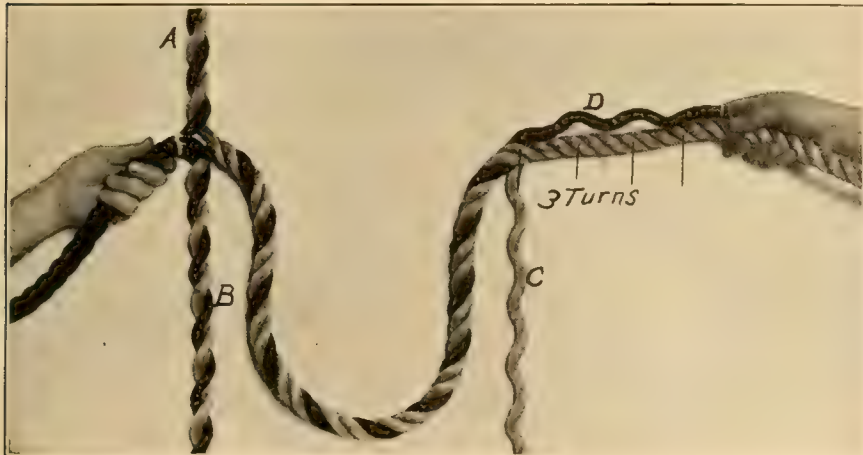

Fig. 53.

Courtesy of the Minnesota Experiment Station

sheaves or pulleys in hoisting and transmission work as the completed splices are the same size as the rope. In making one with three-strand rope:

1. Count off sixteen turns (instead of seven and one-half as shown in Figure 41 for making the short splice) from the ends to be spliced and tie strings tightly around the ropes at the two points thus found.

2. Open and put the ends together in exactly the same way as shown in Figures 43 and 44.

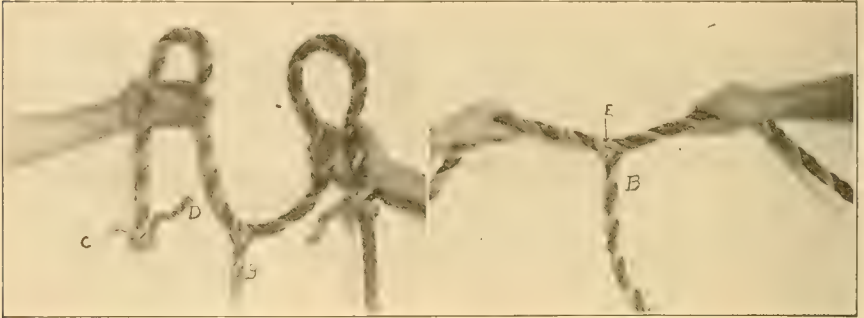

Fig. 54.

Fig. 55.

Courtesy of the Minnesota Experiment Station

3. Select the pairs as shown in Figure 44.

4. Twist two pairs together as shown at A and B in Figure 51.

5. Observing the cautions given below, remove the right hand string and start the splicing by unlaying strand C and laying D in its place as shown in Figure 52. Continue this process until you have left only enough of strand D to reach a little more than three turns as shown in Figure 53. Then half hitch D around the rope so as to hold itself and C from untwisting, as shown in Figure 54.

C and D are on the left of Figure 54. The rope is usually turned as it is easier to work toward the right hand; or else the workman gets on the opposite side of the rope.

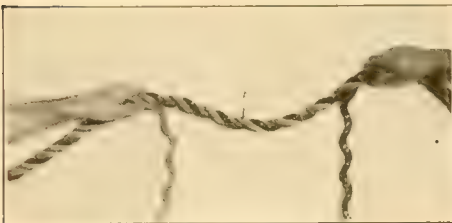

Fig. 56.

Courtesy of the Minnesota Experiment Station

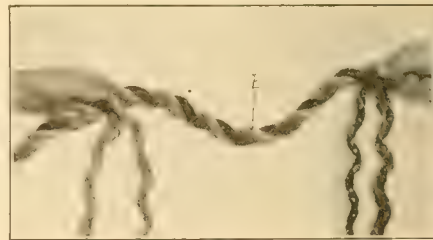

Fig. 57.

Be sure that the ends of the ropes are forced closely together when you begin splicing. Be sure to keep the strand you are relaying, as D in Figure 52 twisted very tightly. As you unlay one strand, as C in Figure 52, relay the other in its place immediately; that is, keep them close together.

6. Untwist the strands at A in Figure 53, remove the other string and then unlay one of the strands and lay the other in its place exactly as you did with C and D, but work in the opposite direction from the center of the splice as shown in Fig. 54.

7. Cut off the middle pair of strands, as shown at B in Fig. 55, leaving enough of each one to reach at least three turns further.

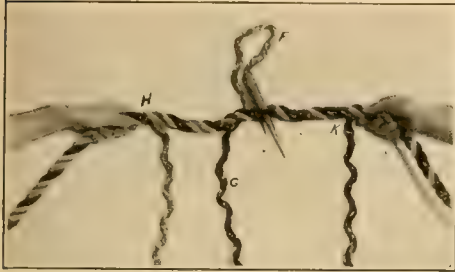

Fig. 58.

Courtesy of the Minnesota Experiment Station

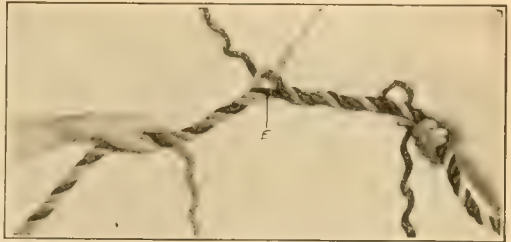

Fig. 59.

8. Underlay each strand of this pair three turns from the center point E, as shown in Fig. 56.

9. Divide each strand into two equal or nearly equal parts, as shown in Fig. 57.

10. Relay one part of each strand three turns again and tie an overhand knot, as shown in Fig. 59. Tie this knot exactly as shown, which is just like the start of the short splice.

11. Draw this knot up tight and then continue twisting these two parts of strands together as shown in Fig. 58. The direction of twist and the method are the same as in making the short splice. Strand F should end at K and strand G should end at H as shown in Fig. 60.

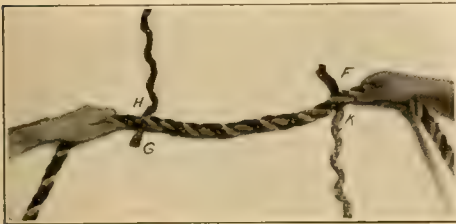

Fig. 60.

Courtesy of the Minnesota Experiment Station



Fig. 61.

Be sure to keep the parts of strand twisted up tight. Do not twist either part of a strand around one of the other whole strands. Have the slope of the twist the same as the slope of the twist in the other whole strands, for these two parts make a whole strand again.

12. Cut the ends of the parts of strands off a short distance from the rope as shown in Fig. 61.

13. Finish one of the other pairs of strands by first loosening the hitch and cutting off the long strand, leaving it equal in length to the short one as shown in Fig. 62. The remainder of the work of finishing this pair is exactly the same as for the center pair, starting with step No. 8.

14. Finish the third pair in a similar way and the completed splice should appear like Fig. 63. There are two parts of strands ending at each of the points M, N, O, P, R, and S.

In making a long splice with four-strand rope:

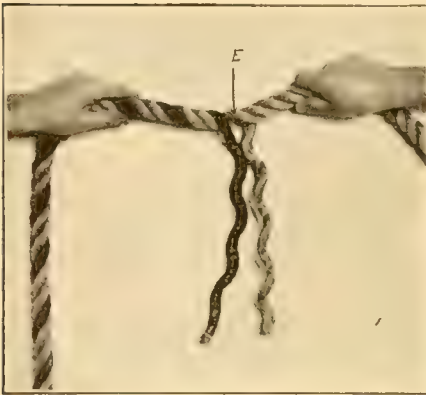

Fig. 62.

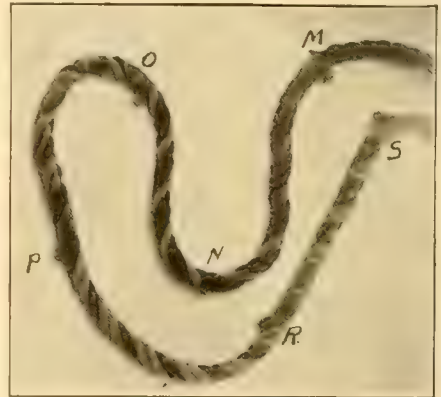

Fig. 63.

Courtesy of the Minnesota Experiment Station

1. Count off twenty-two turns of the strands, instead of sixteen as in making the long splice in the three-strand rope. Be sure to pass over three strands at each count instead of two, and tie strings tightly around the ropes at the two points thus found.

2. Spread the strands out from the centers of the ropes and put the ends together, allowing the cores to pass out on one side as shown in Figure 64.

3. Select the pairs of strands in the way shown in Figure 44, but there are now four pairs.

4. Twist three pairs together as shown at A, B and C in Figure 65.

5. Observing the precautions given in step 5 of the directions for making a long splice in a three-strand rope, remove the right hand string and unlay strand 8 eighteen turns, and lay strand 7 in its place as shown in Figure 66.

6. Remove the left hand string, unlay strand 3 eighteen turns, and lay strand 4 in its place as shown in Figure 66.

7. Unlay strand 2 six turns and lay strand 1 in its place as shown in Figure 67.

8. Unlay strand 5 six turns and lay strand 6 in its place as shown in Figure 67.

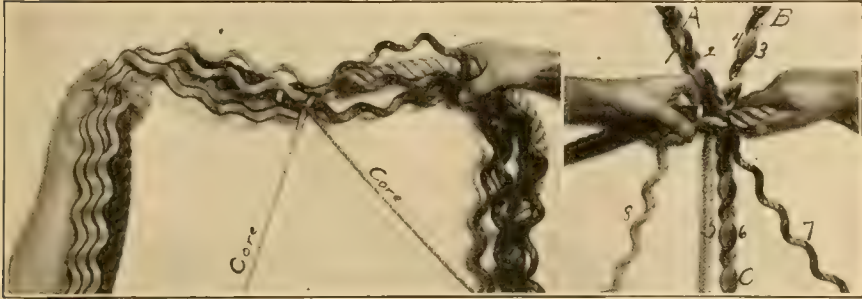

Fig. 64.

Fig. 65.

Courtesy of the Minnesota Experiment Station

9. Cut off all the long strands which are 1, 2, 3, 5, 6 and 8, leaving enough of each one for three more turns.

10. Finish each pair of strands at the points D, E, F and G, Figure 67, using the methods given in steps 8 to 12, and shown in Figs. 56 to 61.

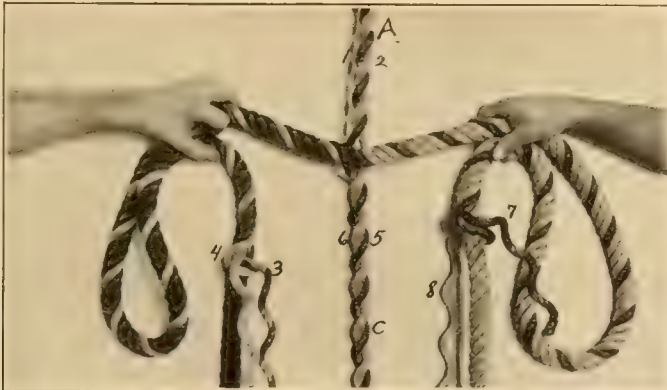

Fig. 66.

Courtesy of the Minnesota Experiment Station

In splicing transmission rope the ends of the half-strands are usually fastened as shown in Figures 68 and 69. In this method one part is divided and the other passed through as shown at H in Figure 68. The end that has not been divided is then tucked under the two adjacent

strands as shown at K in Figure 69. Cut the ends off a short distance from the rope. A four-strand splice finished in this way is shown in Figure 70.

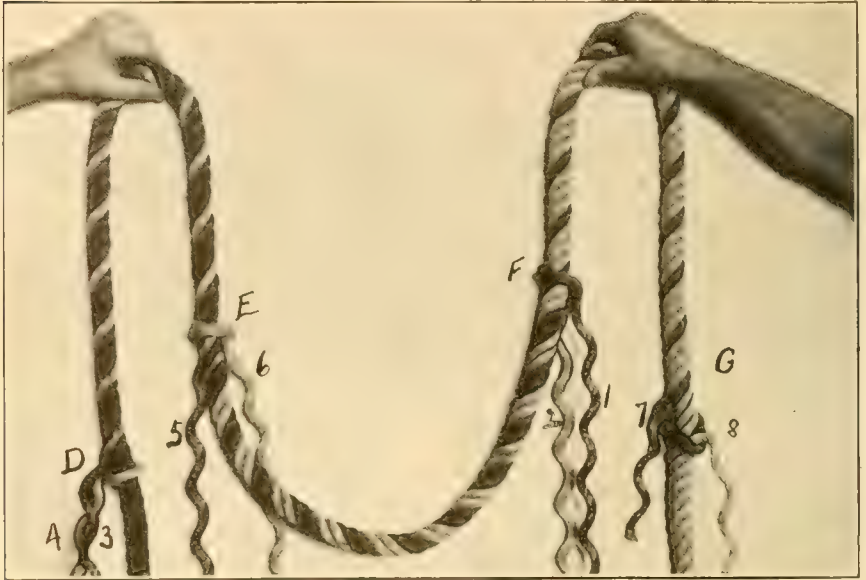

Fig. 67.

Courtesy of the Minnesota Experiment Station

Spliced Eye—The spliced eye is used to fasten a rope permanently into a ring or eye, or to make a permanent loop at the end of a rope. The same method may be used for splicing one rope into the side of another. Learn to make the short splice before trying to make the spliced eye, then follow these directions:

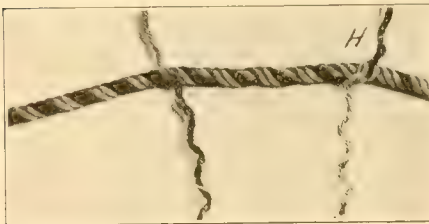

Fig. 68.

Courtesy of the Minnesota Experiment Station

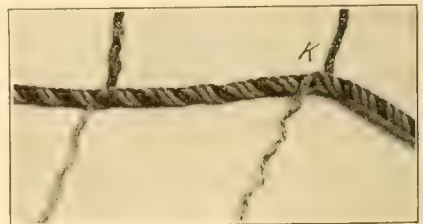

Fig. 69.

1. Unlay the strands about five turns, and start strand 1 under any strand as shown at point B in Figure 71. The distance from A to B should be enough to make an eye of the desired size.

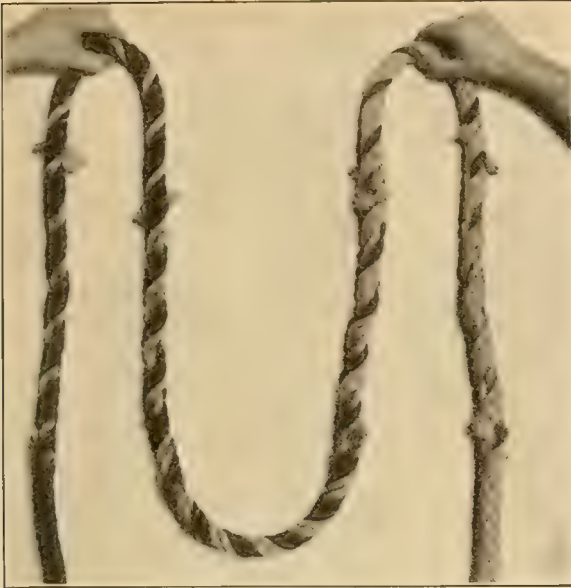

Fig. 70

Courtesy of the Minnesota Experiment Station

2. Draw strand 1 through the rope and start strand 2 under the next strand at point B as shown in Figure 72. Be sure not to get strand 3 in the place of strand 2.

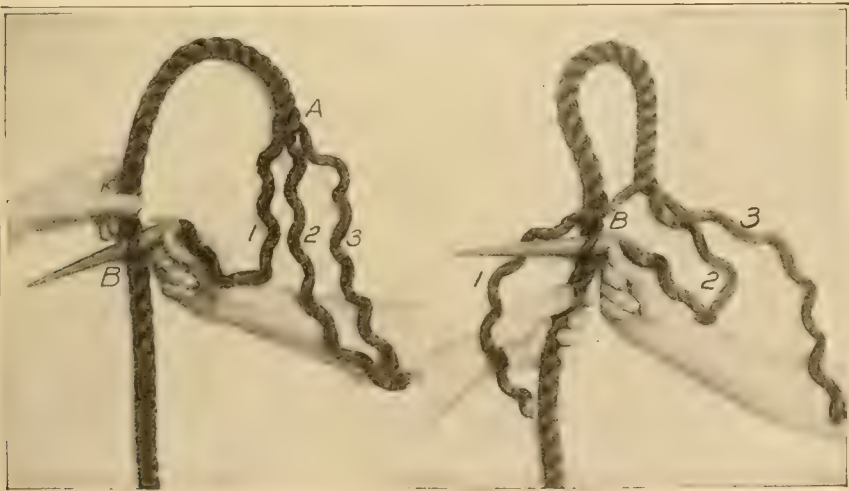

Fig. 71

Fig. 72

Courtesy of the Minnesota Experiment Station

3. Pass strand 3 under the next strand at point B as shown in Fig. 73.

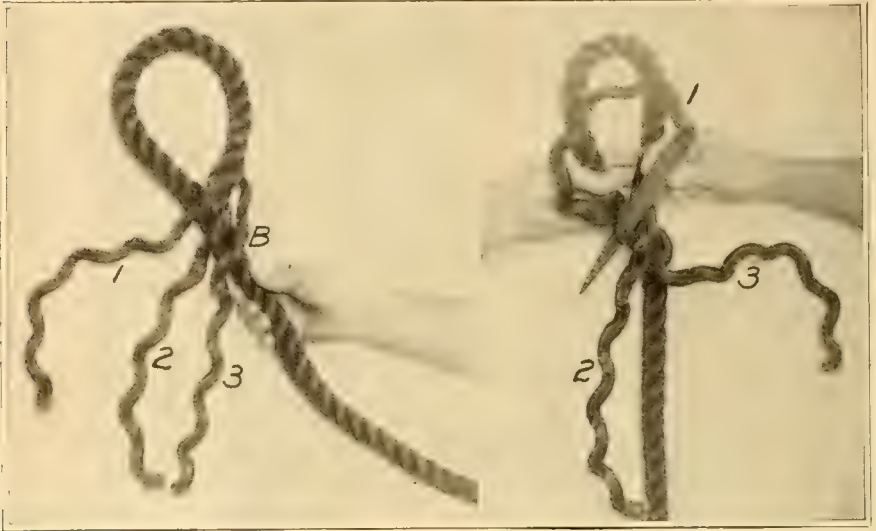

Fig. 73

Fig. 74

Courtesy of the Minnesota Experiment Station

4. Draw the three strands up tight and splice them into the rope just as you do in making the short splice. The remainder of the work is shown in Figs. 74, 75 and 76.

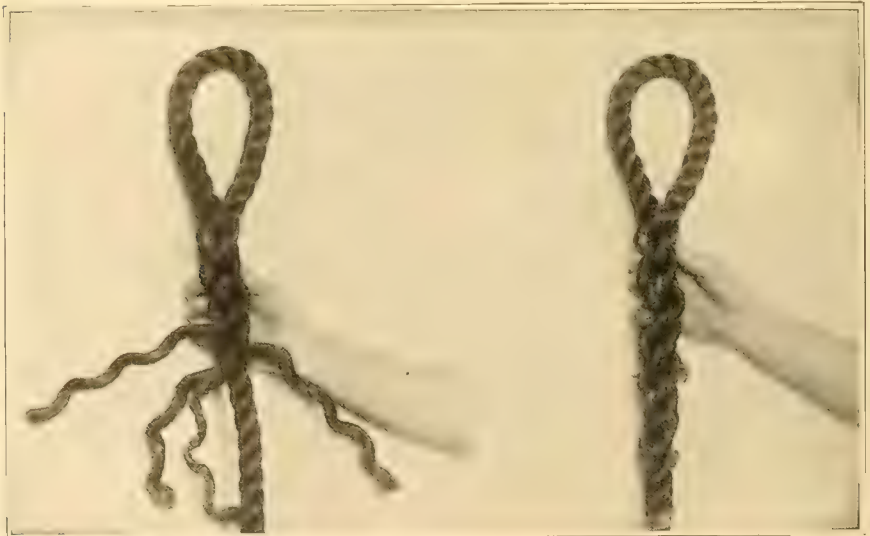
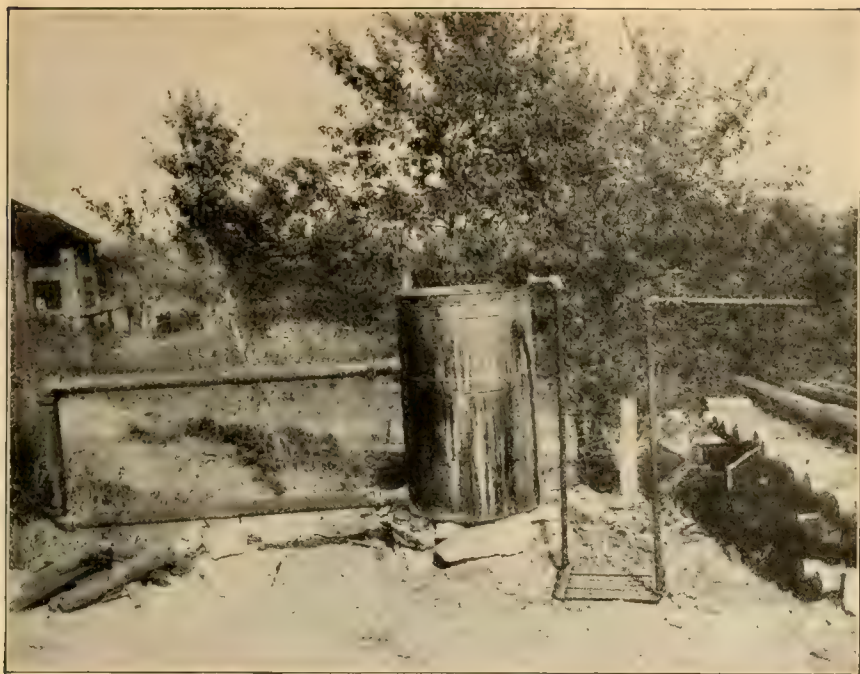

Fig. 75

Fig. 76

Courtesy of the Minnesota Experiment Station



TANK FOR TREATING POSTS

Coil and pipe for heating with steam have been taken out of the tank. The U pipe is shown connected to the same tank and is used when steam cannot be obtained. Heat is applied under the end of the U pipe. The tank is made of 14 gauge sheet iron.

Courtesy of the Minnesota Experiment Station.

PART IV

PRESERVATION AND TREATMENT OF FENCE POSTS

I. INTRODUCTION—LIFE OF UNTREATED POSTS—SUBSTITUTES—COSTS. II. CAUSE OF DECAY—FACTORS AFFECTING DURABILITY. III. PREVENTION OF ROT—OLD METHODS—OTHER TREATMENTS. IV. THE OIL TREATMENT—NON-PRESSURE PROCESS—THE PLANT—THE PROCESS—SINGLE TANK—RESULTS. V. SUMMARY.

There are from eighty to one hundred million fence posts used annually in the United States; this includes both the posts used in new fences and renewals in old fences. The number will increase rather than decrease. This enormous demand for posts would be more easily met if the supply did not come from a comparatively few species now largely exhausted.

Life of Untreated Posts—The life of untreated posts depends on so many conditions—species, age, rate of growth, percentage of sapwood, character of soil and amount of moisture present—that it cannot be estimated definitely. Some will last for many years in contact with the soil, others will rot before they are seasoned.

The following table shows, approximately, the average life of air-dried fence posts of various species:

	No. Years.
Red cedar	30
Black (or yellow) locust.....	20 to 25
Catalpa	20
White oak	15
Black walnut (5 inches round).....	15
White cedar (round)	10
Tamarack	8
Red elm	8
White elm	6
White willow	6
Ash, maple, red and black oaks.....	4 to 5
Birch, basswood, jack pine.....	3 to 5
Cottonwood, aspen	3 to 5

Most of the posts on the market are taken from the first seven species on the list. The other species are used locally, but the annual charge against them is very high when the cost of resetting is considered. The better posts at higher prices are cheaper in the end.

Substitutes—The increasing cost of the durable wooden posts has called forth many substitutes, of which iron and cement have been tried most extensively. There are serious objections to both of them. They are heavy, and high freight charges make it impossible to ship them any distance. Both offer difficulties in attaching wires.

Iron, in spite of its great tendency to rust, even when painted, lasts longer than wood. When set in cement and kept well painted it will last thirty or forty years, but the cost of setting, painting, and shipping, added to the original cost, puts the iron "out of the running" for practical use, in comparison with cedar or a "treated" post of some inferior wood.

The cement post can be made on the ground for 25 or 30 cents, if the proper kind of sand is available. It cannot be used if there is any alkali in the soil to cause the cement to crumble. Its economical use is strictly limited by soil conditions.

Costs—The annual, not the initial, cost is the true basis. It can be estimated properly only by including the cost of maintenance during a given period of years as well as the first cost. Thus it costs about 12 cents to set a post and put on two or three wires. If we consider the average life of one of the quickly decaying woods named above as four years, and its original cost 6 cents, the total cost of setting and renewals for twenty years will be 90 cents, or 4.5 cents per year. On the other hand, a cedar post costing 20 cents would last ten years. The total cost in twenty years is 64 cents, or 3.2 cents per year. If a 6-cent post of inferior wood could be treated for 15 cents so that it would

last the entire twenty years, the total cost for the period would be 35 cents, or 1.65 cents per year. The following table shows a comparison of costs:

COST OF SETTING AND MAINTAINING A MILE OF FENCE POSTS (320)

WOOD	Cost untreated	Cost in 20 Years	Length of life	Annual cost*	Saving in 20 years
Untreated cottonwood.....	\$19.20	\$288.00	4	\$14.40	
White cedar.....	64.00	204.80	10	10.24	\$ 83.20
Treated cottonwood.....	19.20	105.60	20	5.28**	182.40

*Including charge of \$38.40 each time set.

**Including \$48.00 for treating 320 posts.

Thus what seems to be the cheapest fence is far the most expensive in the end. By the use of treated instead of untreated cottonwood posts \$9.12 a year can be saved on every mile of fence in use. There are few easier ways of earning money.

The use of the treated posts has the further advantage of making the farmer entirely independent of dealers and transportation companies, for these inferior species grow so rapidly and abundantly that he can, if need be, grow, as well as treat, his own posts.

The Cause of Decay—The rotting of timber is caused by the work of fungi, very minute living organisms, which get into the crevices of the wood. Rot in wood is very different from rust on iron. The fungi feed on certain substances in the wood and cause it to break down or rot. Like all other living organisms these fungi require heat, air, and moisture, in addition to their food supply. If the soil contains the right amount of air and moisture for the best growth of fungi, the decay of fence posts is rapid, but in very dry soil the decay is slow. Hence the life of a post depends somewhat on the kind of soil in which it is set, and the success of any preservative treatment depends on the degree to which it excludes air and moisture as well as its effectiveness in poisoning the wood.

Factors Affecting Durability—The kind of wood, rate of growth, age of tree, and seasoning, influence the rapidity with which the rotting of wood proceeds. Natural preservatives may be present in the cells, as in the case of catalpa and black locust. Generally speaking, the dark-colored woods are the most durable. Sapwood contains more ready-made food in forms acceptable to fungi than heartwood, so that old trees with much heartwood and little sapwood make better posts. Tests at the Ohio Experiment Station show that slow-growing wood is much more durable than fast-growing wood of the same species. Even black locust when rapidly grown is rather short lived.

Thorough seasoning, or drying, is the cheapest method of lengthening the life of wood and is a necessary preliminary to any further

treatment. Green wood contains about 20 to 50 per cent of water, while thoroughly air-dried wood contains only 15 to 20 per cent. The most satisfactory method for getting rid of the surplus moisture is to pile the green timber so that the air will dry out the wood in six months or a year. If the air circulates too freely, the wood will check and warp in drying. A glance at the structure of the wood shows why checking takes place. A stick of round timber is made up of layers of different density and these layers consist of various kinds of cells. The outside layers naturally dry out first and in drying they must shrink. When the outside layers shrink, and the inside, which is still wet, does not, it is necessary for the outside layers to split. The process continues as long as the difference in shrinkage is sufficient to force rupture. The same forces cause the checking in the ends of boards.

The slower the process of seasoning, the less checking there will be. Hence posts and poles cut in the fall or late summer check much less than those cut in the spring and exposed to the summer heat. Since the ends are likely to dry much more quickly than the middle, it is well to paint them and thus procure more uniform shrinkage. Leaving on the bark, to delay drying and checking, is not a good practice. The bark keeps so much moisture in the wood that ideal conditions for rot fungi are created. In fact there are some species which will rot before they season, if the bark is left on. The time of cutting has little or no direct influence on the durability.

With these points in mind, we should handle round timbers for seasoning about as follows: Peel the timbers as soon as possible after they have been cut. Lay skids on the ground, so that the lower layers of timber will not come in contact with the soil, and in order that the air may circulate freely. In placing the first layer of timbers on the skids, lay them from three to six inches apart. Lay the second layer at right angles to the first, keeping them separated as before. The piles should not be more than four or five feet high on account of the difficulty of handling. Aside from this the piles might be of any height. Build a slanting roof on the pile by putting only one post on one side to give the top layer a slant and put the posts as close as possible to form a roof; or better, cover the top of the pile with boards laid battenwise. If the ends are then painted to prevent cracking, the timbers are in about the best condition to season. It must be remembered, however, that they are sure to crack some, no matter how well they are handled. From four months to a year will be required, according to the species, before the timbers are fairly air-dried.

Prevention of Rot— Every one knows that a post rots most quickly at or near the ground line. It does not rot very rapidly near the top, where it is usually dry, or a foot or more below the ground, where air is lacking; but at the ground line, where both air and moisture are present in sufficient quantities, rot flourishes. This may be further

illustrated by the fact that wood does not rot under water. The piling supporting London bridge was found to be sound after hundreds of years' submersion in the Thames, and in some of the Swiss lakes sound timbers have been found after thousands of years.

Since air and heat are not very easily controlled, it is obvious that rot—that is, fungous growth—must be prevented by cutting off the supply of moisture or poisoning the food. All the modern methods of preserving timber aim consciously at one or both of these objects; all the old methods did the same thing unconsciously, the cause of rot not then being definitely known. These modern methods consist in impregnating the timber, after it is air-dried, with some substance which either calks the openings to keep out the moisture, or poisons the woods so that the fungi are killed.

Old Methods—The early Greeks and Romans used oils, tars, resins, and pitches to preserve timber, either by applying them superficially or by boring holes, thus giving access to the innermost parts of the wood. They also impregnated timbers with crude soda, common salt, and sodium sulphate, and then boiled them in bitumen. The latter process evaporated the water, crystallized the salt, and supplied an external coating impervious to water. The usefulness of these methods was originally ascribed to many fantastic and wholly fictitious reasons, but it has since been found that they protect the timbers from fungous growth.

Charring is probably one of the oldest and most efficient of the old-time processes. It was found that well-charred timbers resisted decay much longer than those not so treated. There is no question of the benefit. The application of the fire dries the outer layer of the wood very effectually. This in itself is a big step toward preservation. In addition the fire burns up the sugar that the fungi feed on and transforms the outer layers of the wood into almost pure carbon, on which most of the fungi cannot subsist. Hence, as long as this layer of carbon remains unbroken, the timber is almost perfectly protected. The charring, however, should not extend more than $\frac{1}{4}$ -inch into the post.

The heat of the fire opens up any cracks that may have been starting and their inner surfaces are charred. Large checks are unlikely to open after this treatment.

At the Wyoming Experiment Station a variation of the charring method was tried, with the result that posts so treated were entirely sound after being set seventeen years, and were good for thirteen years more, while untreated posts had rotted off after being set twelve or fourteen years. The lower ends of the posts, to six inches above the ground line, were dipped for a few minutes in crude petroleum, and the oil was burned off. This drove the hot oil into the post, and, with the charred exterior, prevented decay.

The objections to the charring process are: the time required, the

difficulty of obtaining a thorough and even charring, and the danger of burning the posts so deeply as to impair their strength. Such posts, moreover, should be used only where there is not much danger of the carbon being battered off, for when this occurs the inside of the post is susceptible to rot.

Whitewash is often applied to prevent rot. It also forms a protective coating to keep out the fungous spores. It is effective as long as it lasts, but is not durable. Most whitewash is soluble in water, and is soon washed away. No trace of the protective coating or the antiseptic qualities of the lime remains. It is questionable whether the results warrant the trouble and expense; certainly not when the timber is green, for there is enough moisture inside to support dry rot.

Paint is used in the same way as whitewash and has the same effect. It is also open to the same objections when placed in contact with the ground, where the continued moisture soon softens it. As a protection against the weather it is more durable.

Coal Tar, when applied with a brush or by dipping, has about the same effect as the same kind of treatment with creosote and is about as effective. Possibly it will last a little longer.

Loose stone is a little better to set posts in than earth, because it does not hold the moisture so long, but the gain is so slight that it does not pay. In fact, in some very wet climates it may be worse than earth setting because it permits the drying of butts which would otherwise be kept continually wet.

Poisoning the post near the ground line by means of slanting auger holes filled with poison is fairly effective, but dangerous, and the holes weaken the post. There are many better and cheaper ways.

Other Treatments—"Wood preservation" has recently come to mean, to the general public, the use of creosote, either as an external application or forced into the tissues of the wood. Although creosote is the preservative best known in this country and has been successfully used in Europe for many years, there are other antiseptic substances which are very effective. The materials used may be divided into two classes: those made from mineral salts; and those made from various heavy oils, mostly derived from the manufacture of coal gas. They are all more or less poisonous to fungi and bacteria.

The mineral salts most commonly used are zinc chloride, copper sulphate, and bichloride of mercury. All of these substances possess the advantage of cheapness. The salts themselves are cheap, and the fact that they are shipped in dry form and mixed for use at the point of consumption makes low freight charges. They all possess the disadvantage of leaching out of the wood when exposed to moisture.

Zinc chloride is the best of the mineral salts; it is cheapest, does not corrode metal, attacks neither the tanks in which the treating is done nor the nails driven into the treated timber, and is not poisonous to

animal life. It is soaked into the wood in the form of a 2 to 6 per cent solution in water. The water then evaporates, leaving the dry zinc chloride in the cells. This material is poisonous to fungi and prevents their growth, while it is present. The trouble is that this salt is soluble in water. Every time there is a rain, a portion of it dissolves and is washed out of the wood. It may, however, be used in the protected places where there is danger from dry rot.

Similar objections apply to copper sulphate and bichloride of mercury, both of which have been tried, but are very little used.

The heavy oils of coal tar and petroleum are not subject to the objections made to the mineral salts, that they readily dissolve in water. Most of these oils possess the antiseptic qualities of the salts; and being heavier than water and insoluble in it, are little affected by it.

There are many of these oils on the market, ranging in price from 6 cents a gallon, for some of the crude materials, up to \$1.00 a gallon for some of the patented treating materials. Most of them have commercial creosote for a basis. This is a by-product in the manufacture of illuminating gas from coal. Owing to its efficiency, cheapness, and past record, creosote and "Barrett's Grade One Liquid Creosote" are considered the material best suited for use on the farm in the preservation of fence posts, at the present time:

Preservative treatment with creosote, though considered a new thing in this country, has been used in England and France for a long time, especially with railroad ties. Treating companies there guarantee treated beech ties for fifteen years' service, when, untreated, they would not last two years. Practically all their ties and other timbers which come in contact with the soil, or are subject to constant wetting and drying, are now treated. Even in this country, although comparatively few people know it, there are millions of ties, poles, and paving blocks treated every year. Their durability is thereby increased two-, three-, and sometimes tenfold.

Creosote, also "Barrett's Grade One Liquid Creosote," is a greenish brown oil slightly heavier than water. It burns fiercely when ignited, but does not ignite easily unless already heated to a high temperature. At a low temperature it crystallizes into a semi-solid state, but is entirely fluid when heated above 100 degrees F. Like most coal-tar products, it has a strong odor, disagreeable to some people. The cheaper grades of creosote evaporate at a low temperature if exposed for some time. In some tests conducted by the United States Forest Service, 75 per cent of the oil was lost by evaporation in two weeks' time when kept at temperatures ranging above 100 degrees F., and at 208 degrees F. over 80 per cent was volatilized. Better grades of oil showed less than one-third of this loss. Since it is necessary to heat the creosote in open tanks when using it on a farm, it will pay to use the better grades. The cheaper creosotes also evaporate more rapidly from the posts after

the treatment, and this leaves less of the heavier constituents, which are the real preservatives.

A barrel of creosote contains about fifty gallons and the oil weighs from eight to eight and one-half pounds per gallon. The cost in barrel lots varies from 15 to 25 cents per gallon up to 50 or 60 cents for the better grades. In larger quantities the prices are less.

The creosote may be tested by heating. At 100 degrees 95 per cent of it should be liquid, and at 235 degrees F. not more than 15 per cent should have evaporated. An oil which comes up to this standard will

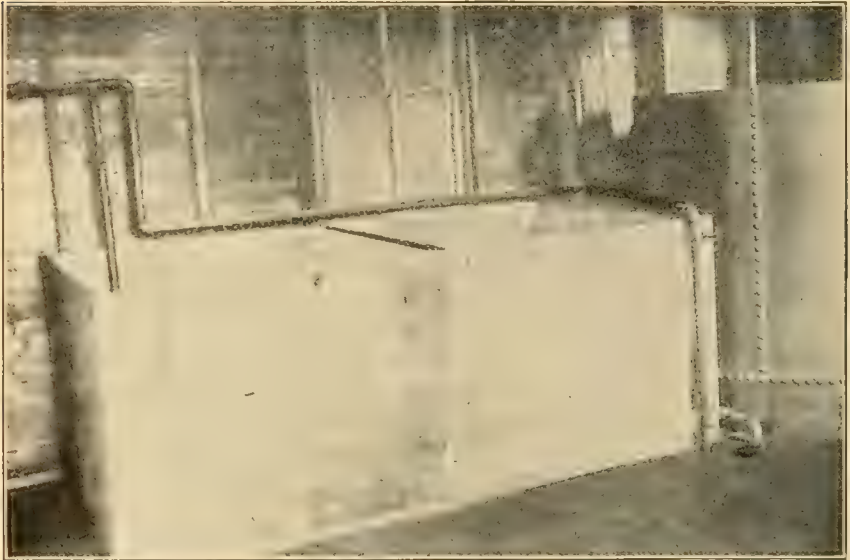

FIG. 1.—RECTANGULAR TANK

This tank is 4x4x8 feet, with steam pipes attached, and is used in the laboratory at Minnesota University Farm. The pipes above the tank are oil pipes, used in filling and emptying the tank when the number of posts treated will warrant the use of a pump. The appliance for holding the posts under the oil does not show in this picture. The tank is made of 14 gauge sheet iron.

Courtesy of the Minnesota Experiment Station

show comparatively small loss from evaporation and seems best adapted to treating fence posts.

METHODS OF OIL TREATMENT

The methods of applying the oil to timber may be divided into two classes, pressure and non-pressure processes.

The pressure processes have been most extensively tried, especially in the treatment of railroad ties and paving blocks, which require a very heavy impregnation. This requires very expensive apparatus, consisting of airtight cylinders large enough to hold a train of small cars, huge storage tanks, powerful pressure pumps, and quite a system of tracks connecting the plant and the storage yards.

The Non-Pressure Process—The “non-pressure,” or “open tank” plant is the least expensive that will creosote timber efficiently. It is especially well suited to the treatment of fence posts and poles.

The plant may consist of either one or two tanks. If it is to be used from year to year and a large number of posts — say 50,000 — are to be treated, the tanks must be large; otherwise, the small portable plant, which can be taken from farm to farm, is much more suitable for the work. Such an outfit, complete, would consist of a tank three and one-half feet in diameter and three and one-half feet deep, and a rectangular tank 4x4x8 feet, two large iron hooks for handling the wet posts and a thermometer reading to 300 degrees F.

If steam is available for heating purposes, from a traction engine, a creamery boiler, or a mill boiler of any kind, the tank should be made of 14-gauge galvanized iron and reinforced with three-quarter inch angle iron, as shown in the illustration. A gridiron coil of one and one-half inch pipe is made for the inside of the bottom of the round tank and a single pipe of the same size is run around inside the bottom of the large tank. These pipes are connected with the boiler and each fitted with two globe valves, one where the pipe enters the tank, the other where it leaves it. If the round tank can be set in the ground a foot, it will greatly facilitate the handling of the posts.

On one side of the large tank two 2x4's, YZ, arranged as shown in Fig. 3, should be firmly planted in the ground. Cut a 2x8, ABC, a trifle shorter than the width of a square tank. In the center of this, and at right angles to it, toenail the end of a 2x8, CD, about two feet long, so that it will stand perpendicular to the first piece. Brace it securely. A strong pole, EF, ten or twelve feet long and about four inches in diameter completes the equipment, unless it is necessary to brace the long sides of the tank to keep them from bulging. The T-shaped piece, ABCD, is placed on the top of the posts, the long 2x8, ACB, being crosswise of the center of the tank with the crosspiece CD projecting vertically. The long pole, EF, is then placed across the top of the upright, CD, with one end under

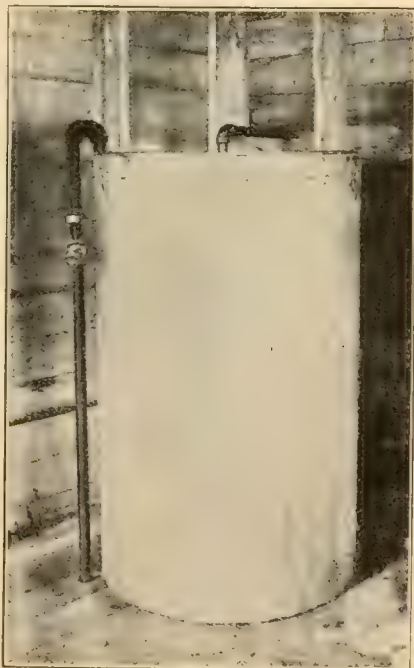

Fig. 2.—Tank used with steam heat. There is a steam coil in the bottom of the tank like the one shown on front page.

Courtesy of the Minnesota Experiment Station

the crosspiece, X, on the posts, Y and Z. A downward pressure on the other end of the pole, EF, will then force the posts down into the liquid. The end of the pole can then be tied down.

The heat in the tanks is regulated by means of valves. To raise the temperature, close the outlet and open the intake. It is necessary to open the outlet from time to time to blow off the condensed steam. Be careful not to stand in front of the blow-off, or a bad scald may result. To lower temperature, close the intake and open the outlet. A little experience will enable the operator to easily maintain an even temperature.

Such an equipment as this is recommended only where speed in

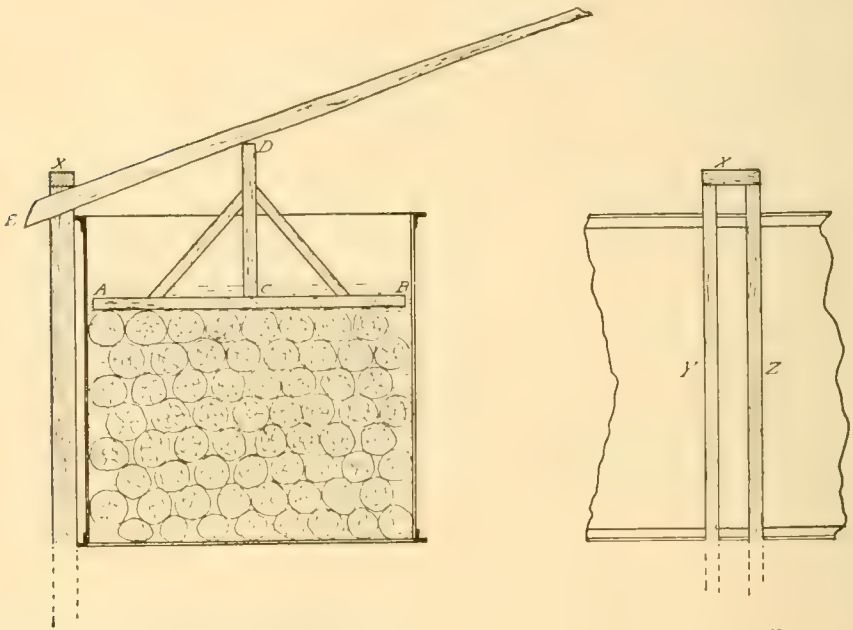

Fig. 3.—Appliance used in holding posts under the surface of the oil.

Courtesy of the Minnesota Experiment Station

operating is essential and where a large number of posts are to be treated in one place, that is, where the plant is comparatively permanent.

If no steam is available, the same kind of tanks will be used, but they will be made of black iron, and must be so arranged that a fire can be built under them. This will necessitate building a brick fireplace on which the tanks can be raised, or digging out a firebox in the ground under them. In either case some provision must be made to support the bottoms of the tanks, as they are not strong enough to stand the pressure if supported only at the edges. Two old railroad rails do well for this.

If the tanks are raised on a foundation, it will probably be necessary

to build a working platform around them, or else to set the tanks on a hillside to avoid lifting the posts so high. Just as good results may be obtained in this way as with steam, but it is a little more difficult to keep the temperature even, and care must be taken that the flames do not ignite the drippings on the sides of the tanks and thus set fire to the oil inside. Plenty of water should be kept on hand for use in case



FIG. 4. SINGLE TANK HEATED BY DIRECT FIRE

It is located on the side hill for convenience in handling posts. The tank should be made of block iron. Note the smoke stack.

Courtesy of the Minnesota Experiment Station.

of fire. The oil is heavier than water; hence, if the oil should catch fire, water poured into the tanks will remain on the surface and smother the flames. The water should be poured on gently; if it is dashed on violently, it will mix in with the oil temporarily and fail in its purpose.

The Process—Green timber cannot be treated, because it is full of water and the oil cannot go in until the water has come out. Hence, the timber must be thoroughly seasoned. The bark, even the thin inner

bark, must be completely removed, because it prevents the entrance of oil into the wood, and takes up oil which is wasted when the bark finally comes off, as it always does.

The cylindrical tank is partially filled with oil — which will probably be so solid that it can be put in with a shovel — and heated until the oil becomes thoroughly fluid. The tank is then filled with posts, set upright, butts down. It will hold from twenty-five to sixty, according to the size of the posts. The oil should cover the butts at least six inches above the ground line. The oil is then heated to 220 degrees F. and kept there. When the posts are heated in this way, the air in the cells expands and part of it is driven out. The length of the bath in this tank will vary from twenty minutes to two or three hours, according to the species and the condition of the timber in the posts.

The posts are then removed to the rectangular tank, in which the oil is maintained at a temperature of about 110 degrees F. This may be tested with a thermometer fastened in a grooved stick to prevent breakage. The lower temperature in this tank causes the air remaining in the cells to contract and the partial vacuum thus formed is filled with oil. The posts are placed horizontally and completely submerged in oil. As the oil is heavier than water, the posts will float very high and must be forced under. This can best be accomplished by the apparatus shown in the diagram.

The result of this process is a satisfactory penetration of that portion of the post which was submerged in the hot oil and a simple dipping of the top of the post which needs very little protection. Where the climatic conditions are such that the top of the post is not likely to rot during the term of service, only the butts need be submerged in the cool oil and the tops left untreated, or the tops can be given a brush treatment.

Single Tank — Where a single tank is used the process is exactly the same as the above except that instead of moving the posts to the cool tank at the end of the hot bath the fires are drawn and the oil allowed to cool.

The results are quite as good as with the two tanks, but of course the method is slower and some time is lost in raising the temperature of the oil after each cool bath.

The simplest form of treatment is a single cylindrical tank equipped with a 4-foot "U" of one and one-half inch pipe as shown in Fig. 5. It should not cost more than fifteen or sixteen dollars. The "U" should be attached to the tank by means of lock nuts. The fire is built under this pipe instead of under the tank. The temperature can easily be controlled in this way and there is less danger of fire in case of overflow from the tank. The posts can be reversed and the tops either dipped or given a brush treatment where such seems advisable. In order to economize oil, it is best to treat the butts of all the posts first and then apply the oil

which is left in the tank after the last treatment to the tops of the posts with a brush. This must otherwise be wasted or kept in the tank until the next lot of posts is treated.

Results — Some kinds of wood seem almost impervious to oil under any form of treatment. Others are so easily penetrated that care must be taken to keep them from absorbing enough to make the cost prohibitive.

With balsam, spruce and maple, the penetration obtained is so slight in depth, even with long hot and cold baths, that it seems like a waste of time to give them more than a dip or a brush treatment.

White oak, tamarack, white cedar, red cedar, locust, and similar woods, are not difficult to treat, but they last so long without treatment that the use of preservatives is not warranted.

Red oak lends itself more readily to treatment than any other hardwood. A complete penetration of the sapwood can always be obtained with

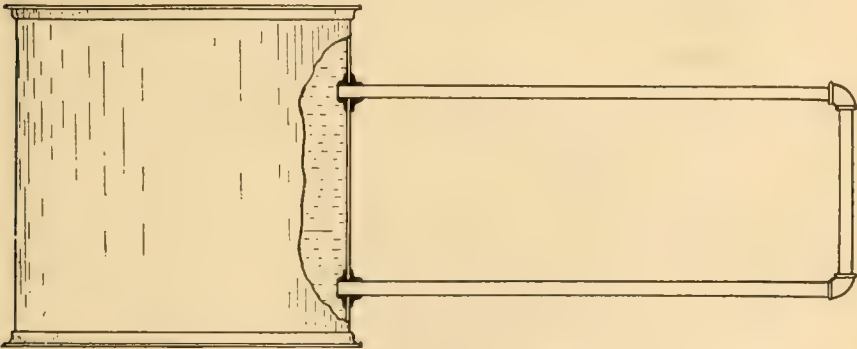

FIG. 5. OUTLINE OF TANK

This shows the U pipe connection. The tank is made of 14 gauge sheet iron. A photograph of a tank of this kind appears at the head of the chapter.

Courtesy of the Minnesota Experiment Station

short treatments, and with the absorption of a comparatively small amount of oil. The heartwood cannot be treated nearly so easily, so round posts are preferable to split ones.

Cottonwood, poplar (*Populus tremuloides*), willow, and jack pine are all capable of a satisfactory penetration with short treatments and a small quantity of oil. This is exceedingly fortunate, because the hardness of these trees and their rapid growth make it possible to grow them profitably on the farm.

Ash is quite easily handled and the results are fairly satisfactory, but the wood is so well suited to more profitable purposes that its growth for fence posts is not recommended.

Basswood is very difficult to treat satisfactorily. The penetration obtained from the short treatment is little more than a superficial coating, while the amount of oil absorbed in long treatments is prohibitive. Fairly good results were obtained from a very long bath in cooling oil, but this

method is too slow to be practicable. Probably the dipping or brush treatment would pay the best.

The following table gives the treatments which have proved most satisfactory and the results which may reasonably be expected from them. These cannot be taken as exact directions since the degree of seasoning and the rate of growth of the posts treated will greatly influence results. Careful observations should be made of the results of these treatments and the duration of the hot bath lengthened or shortened to meet the conditions.

Experiments have been conducted to determine the amount of oil required to treat posts of various kinds by different methods and the depth to which the oil penetrated in each case. The cost of treatment per post was also determined. For ash, cottonwood, and poplar the best treatment seemed to be a thirty-minute hot bath followed by a forty-five minute cold bath in creosote. Only the butts of the posts were treated. The following table states the oil absorbed, the penetration secured, and the cost of treatment:

Species	Oil absorbed	Penetration	Cost in cents		
			Oil	Labor	Total
	Pounds	Inches			
Ash.....	1.9	0.37	4.5	2.0	6.5
Cottonwood.....	2.25	.42	5.4	2.0	7.4
Poplar.....	2.25	.42	5.4	2.0	7.4

For jack pine and red oak the best treatment appeared to be a sixty-minute hot bath followed by a thirty-minute cold bath. The following table states the results secured:

Species	Oil absorbed	Penetration	Cost in cents		
			Oil	Labor	Total
	Pounds	Inches			
Jack Pine.....	1.55	0.46	3.7	2.0	5.7
Red Oak.....	2.0	.25	5.0	2.0	7.0

For basswood posts the best method of using creosote seemed to be to heat it to 220 degrees F., then allow it to cool over night. After this treatment each post absorbed 0.9 pounds of oil and a penetration of about one-quarter of an inch was secured at a cost of 2.2 cents per post for oil and 2 cents per post for labor—a total of 4.2 cents per post.

For ash, balsam, basswood, cedar, maple, tamarack and white oak good results were secured by dipping the butts for two minutes. This gave a penetration of 0.05 inches and required 0.6 pounds of oil per post. The total cost per post was only 2.5 cents—one cent for labor and 1.5 cents for oil.

A brush application of two coats of hot oil to a zone extending a foot below the ground line and eight inches above gave good results with ash. The United States Forest Service has secured very good results with oak by this method. The average cost per ash post at the Minnesota University

Farm was 2.6 cents—2 cents for labor and 0.6 cents for creosote. This treatment gave good results with balsam, basswood, cedar, poplar, tamarack, white oak and maple as well as with ash.

Summary—The treated post is most economical in many sections. Experiments at the Minnesota University Farm and experience elsewhere have shown that creosote costing ten cents or less per post will penetrate peeled, seasoned jack pine, poplar, cottonwood, willow, red oak, or ash posts from a quarter to a half inch deep.

Maple, basswood, birch, spruce, and balsam should be given two coats of hot oil with a brush. This will increase their durability at a very low cost. Little more can be done with them even by more elaborate and very much more expensive methods.

Cedar, white oak, and tamarack can be treated quite readily, but when treated they are no better than the cheaper woods, so their use for this purpose is unwarranted.

The posts for this work should be cut in the spring when they can be easily and thoroughly peeled, for even a thin inner layer of bark is a great hindrance to the penetration of the oil. They should then be carefully piled so that there will be a good circulation of air. Skids should be put under the pile to keep the bottom tier of posts off the ground. The treating can then be done late in the summer, or early in the fall.

That the original cost of equipment may not be an excessive charge it is not advisable to put in a single-tank plant where there are less than 2,000 posts available for treatment, or a double-tank plant where there are less than 6,000. There are few farmers who have so many posts that they want to keep an equipment for their own use; hence, it is recommended that the plant be handled by a Farmers' Club, Co-operative Creamery, Agricultural High School or some other form of joint or co-operative ownership. In this way a large number of posts can be handled by the use of a single plant, and the more posts treated the less the rent charge for the equipment.

The small single-tank plant can easily be loaded on a farm wagon and hauled from farm to farm, thus avoiding the handling of posts. For this reason the single tank is recommended for use on the farm.

Creosote, and liquid creosote, of a satisfactory grade can be bought in barrel lots at a cost of from 25 cents to 35 cents per gallon.

Any one desiring to take up this work can obtain detailed plans to suit the conditions by writing to the College of Forestry, University Farm, St. Paul, Minnesota.

PART V.—HOUSEHOLD LABOR-SAVING DEVICES

CHAPTER I

THE KITCHEN AND CULINARY HINTS

I. INTRODUCTION. II. THE KITCHEN. III. CULINARY HINTS—WEIGHTS AND MEASURES—APPROXIMATE MEASURES OF ONE POUND—OF ONE OUNCE—GENERAL MEASURES—PROPORTIONS FOR THICKENING AGENTS—FOR LEAVENING AGENTS—FOR SHORTENING—TO SET A TABLE—MEAT—BREAD—CEREALS—CAKES AND COOKIES—PASTRY—JELLY MAKING—CANNING FRUITS—CANNING VEGETABLES—MISCELLANEOUS SUGGESTIONS.

INTRODUCTION

The use of many improved implements and methods on the farm is now so general that they are regarded as a matter of course. The home, which exceeds the field in importance, has in many cases not received its fair share of thought and attention. Many of the farm implements are in use only a short time during the year and stand idle for the rest of the time, while a much needed tool for the kitchen is considered an unnecessary expense. When it is realized by the women themselves how much their work would be lightened by the intelligent use of the devices made for their assistance they will insist upon having them. Most of the labor-saving tools mentioned in this chapter are not costly. Suggestions are also given for the work in the kitchen and the laundry, with conveniences that may be made by the handy man in the home. No attempt is made to cover the whole range of this subject as the scope of the book does not permit it.

Before buying any equipment for the kitchen the housekeeper should be sure that it is needed, that she will use it, and that it is a good investment. Then she should buy the most satisfactory one on the market. A few tools well chosen will give better satisfaction than a dozen poor ones. Not how many, but how few are necessary for the greatest efficiency, is the problem for the housekeeper to solve. Improving one's methods will often do as much to lessen drudgery as tools. There is a best way and an easiest way to do everything. To search constantly for it will make work so interesting that it will cease to be drudgery.

THE KITCHEN

Every woman should have the planning of her kitchen as it is her own particular workshop. Its relation to the rest of the house, its size, lighting arrangement and equipment should all be given careful thought.

A large room used to be considered necessary for the kitchen. Too often it was used as a place for cooking, eating, washing and ironing, washing hands, shaving and changing muddy boots and overalls. Fortunately the small, sanitary and convenient kitchen has taken its place in most homes. Separate rooms for duties not related to the preparing of food make it possible to keep a cleaner and more systematic kitchen.

The woodwork in the kitchen should be perfectly smooth. Grooves and crevices are sure to fill with dust and are hard to keep clean. It should be painted or enameled in white or light colors. These cost no more than drab, dull colors and add to the charm and light of the room. All windows should be placed high enough to allow the space beneath them to be used. There should be sufficient window space to furnish plenty of light and ventilation. When the wall space is limited the door may be glassed or a transom fitted over the door.

A serviceable sink is of enamelled iron, large enough to hold two pans or a large dishpan. It should always be open beneath, for woodwork will become foul and decay. Drain boards at the right and the left of the sink add to the table space in the kitchen. The surface of the drain boards should always be treated so that it will be non-absorbent. A simple way is to coat them with a wood filler and finish with linseed oil.

Built-in cupboards are desirable where possible as they do away with crevices beneath and behind them where dust would lodge. Narrow shelving that will hold but one row of supplies is easier to keep in order and to get at. There should be a cupboard between the kitchen and dining room opening both ways.

If the work table, the sink, the ironing board and the stove are all at just the right height for the worker, it will add greatly to her comfort and efficiency.

A dumb waiter, or lift, between the basement and the kitchen will save many trips downstairs. This may be a set of shelves run by weights and pulleys, that can be lowered or raised from the kitchen.

A wheel tray or a double-decked small table on casters is a great convenience in the kitchen. All the dishes for one meal can be loaded on it and taken to the dining table at one trip. After the meal it is loaded with the soiled dishes and pushed to the right of the sink.

The kitchen range will look better and be easier to keep clean if it is simple in line and finish. The ornamental stove covered with useless scroll work and nickle-plate makes needless work.

The floor covering of the kitchen should be such that it will stand frequent, thorough washing. Nothing that will absorb moisture, or stain with grease, should be used. Linoleum, tile, or a cork covering now made, are the best materials to use.

Mrs. Frederick the "kitchen expert" divides kitchen work into two main processes. "Every task done," she says, "peeling potatoes or

washing a skillet, can be divided clearly under one or the other group. One group is those processes which prepare a meal; the second group is those processes which clear away a meal. Each of these processes cover distinct equipment."

In preparing a meal all foods are:

1. Prepared.
2. Cooked.
3. Served.

The equipment used is:

1. Icebox, pantry, table, kitchen cabinet.
2. Stove, utensils.
3. Table, trays.

In clearing away a meal all foods, utensils, dishes are:

1. Removed.
2. Washed.
3. Laid away.

The equipment used is:

1. Trays, tables.
2. Sink, drain.
3. Closets, pantry, icebox.

In Mrs. Frederick's Efficiency Kitchen the refrigerator, kitchen-cabinet, stove and table are in one group, placed so that food from the icebox is placed on the cabinet table next to it, in preparation for cooking on the stove next to it, and lifted when finished from the stove to the metal-topped table next to it. From icebox all the way to the dining room is in one direction.

On the other side of the kitchen entirely, and moving in the opposite direction, is the clearing-away-process group. The sink, drain boards, and china closet are close together. The materials are brought from the dining room and the dishes are put through the cleaning and putting-away process, all in one direction. (See Figures 1 and 2.)

"It is so easy," says Mrs. Frederick, "to have the equipment in the right relations, but how many kitchens there are where the sink is next the pantry, where it is useless; where the stove and sink are adjacent; where the china shelves and the stove are alongside, with nothing to do with each other."

The big central idea in the arrangement of a kitchen is to efficiently route the processes and work that go on there, in order to save cross-stepping, confusion and energy.

CULINARY HINTS

Weights and Measures

20 drops—1 teaspoon.

2 cups—1 pint.

60 drops—1 tablespoon.

1 cup— $\frac{1}{2}$ pint or 8 ounces.

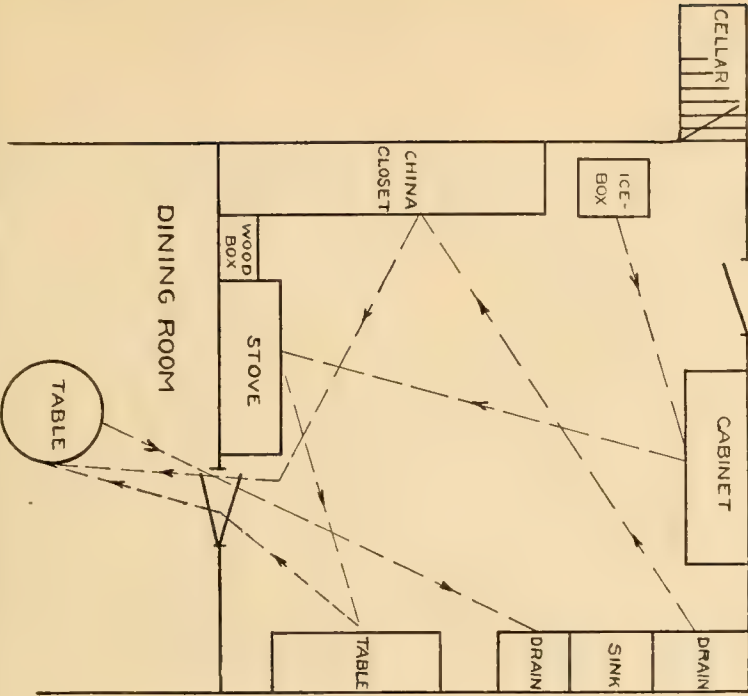

Fig. 1.—A badly-arranged kitchen. Note the many steps and inter-secting travel-routes in preparing and clearing away a meal (indicated in the dotted lines).

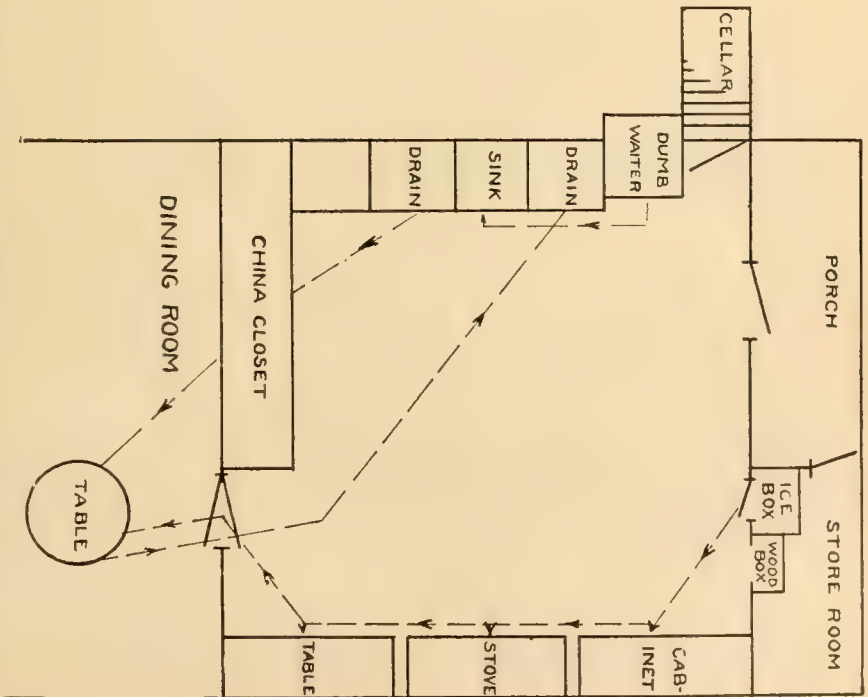

Fig. 2.—A well-arranged kitchen. The equipment is so placed that in either preparing or clearing a meal the travel-routes are shortened and direct.

Juice of 1 lemon—1 tablespoon. 4 cups or 2 pints—1 quart.
 3 teaspoons—1 tablespoon. 4 quarts—1 gallon.
 16 tablespoons—1 cup.

Approximate Measure of One Pound.

2 cups butter.	4½ cups graham flour.
2 cups granulated sugar.	2 cups chopped meat.
2 2-3 cups powdered sugar.	2 cups chopped nuts.
2 2-3 cups brown sugar.	10 medium sized eggs.
4 cups flour.	2 cups water, vinegar or milk.
3 cups corn meal.	

Approximate Measure of One Ounce.

4 tablespoons flour.	2 tablespoons milk.
2 tablespoons butter.	2 tablespoons sugar.

All measures are taken level, the cup or spoon is filled more than full and it is then leveled off even with edges of the spoon with a case knife.

To measure a half spoonful divide spoon in center, (lengthwise) with a knife. A half a spoonful divided in the middle (crosswise) equals a quarter of a spoonful.

A few grains is as much as will rest on the tip of a pointed paring knife.

Proportions for Thickening Agents.

1 tablespoon of flour thickens 1 cup of liquid for soups.
 2 tablespoons of flour thickens 1 cup of drippings for gravies and sauces.
 4 tablespoons corn starch stiffens 1 pint of liquid.
 2 eggs to 1 pint of milk makes a custard.
 1 egg to 1 cup of milk makes a soft baked custard.
 1 tablespoon gelatine or jello stiffens 1 pint of liquid.

Proportions for Leavening or Lightening Agents.

2 teaspoons baking powder to 1 cup flour.
 ½ teaspoon soda with one cup sour milk.
 ½ teaspoon soda with one-half cup of molasses.
 1½ teaspoon soda with one and a quarter teaspoons of cream of tartar.
 2 teaspoons baking powder are equal to ½ teaspoon of soda, when used in place of soda as given above. Use one teaspoon less of baking powder for each egg, after two spoonfuls have been used.

Proportions for Shortening.

2 cups flour to ½ cup shortening for ordinary pie crust.
 2 cups flour to ½ cup shortening for cookies.
 2 cups flour to 6 tablespoons shortening for cake.

2 cups flour to 4 tablespoons shortening for shortcake.

2 cups flour to 2 tablespoons shortening for biscuits.

Meat

Tough meats that are for soup, should be put into cold water and cooked very slowly. Other cuts of meats should be placed in hot water to keep all juices and nutrients in the meat.

Clean meat by washing with a cloth and warm water. When meat is washed by placing in water, the juices run out and the food value is lost.

Sausage may be kept from bursting when frying by rolling in flour before browning.

Keep sausage fresh by packing in a stone jar and covering with hot lard.

Cured hams that have been cut into may be kept fresh for a long time by spreading fresh lard over the newly cut place.

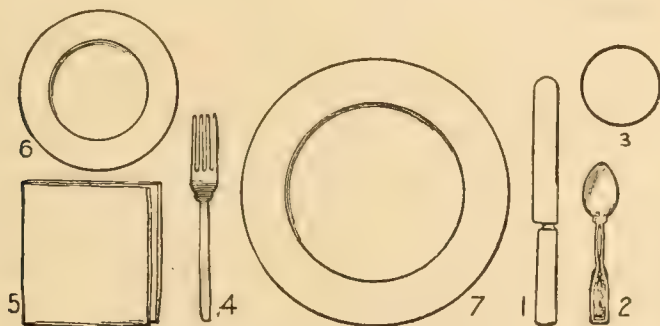

FIG. 3.—PROPER WAY FOR LAYING A PLACE AT THE TABLE

1, Knife; 2, Spoons; 3, Glass of Water; 4, Fork; 5, Napkin; 6, Bread and Butter Plate; 7, Plate; 8, Other Spoons are placed at the side of No. 2.

Add a few drops of vinegar to the water in which meat is cooking and the cooking of the meat will be hastened. It will also have a better flavor.

Left over pieces of meats can be made into croquettes, meat pies, or soups; or a thick gravy can be made by adding the chopped meat to an ordinary gravy.

A double boiler is the best utensil to use in trying out small portions of fat. There is no danger of burning the fat and the odor is much less noticeable than if it is heated in a dish set directly over the fire.

Clarifying Fat — Excepting where the purpose of clarifying fat is to remove flavors, a good method to follow is to pour boiling water over the fat, to boil thoroughly, and then to set it away to cool. The cold fat may be removed in a solid cake and any impurities clinging to it may be scraped off, as they will be found at the bottom of the layer.

By repeating this process two or three times a cake of clean, white fat may be obtained.

A slight burned taste or similar objectionable flavors often can be removed from fat by means of potatoes. After melting the fat, put into it thick slices of raw potato; heat gradually. When the fat ceases to bubble and the potatoes are brown, strain through a cloth placed in a wire strainer.

Savory Drippings — When rendering the drippings of fat meat, add a small onion (do not cut it), a few leaves of summer savory and thyme, a teaspoonful of salt, and a little pepper. This is enough for a pint of fat. Keep the drippings covered and in a cool place.

NOTE — For further discussion on meats see chapter on Butchering, Dressing and Curing of Meats.

Bread

When setting yeast for bread the night before baking, cover it well with a cloth, and set on the back of the cook stove over night. If the stove is slightly warm it will cause the yeast to rise and be very light in the morning.

When bread is slow in rising, place the pan of bread in another pan which has been filled one-third full of warm water. As the water cools add hot water to it. Never make it hotter than the hand can be held in. In cold weather, warm the flour, bowls, pans and board to hasten the raising of the bread.

If bread is made with milk it will keep moist for a longer time than when made with water.

A little sugar added to the yeast, when making bread, will hasten the growth of the yeast plants and thus cause the bread to raise sooner.

When bread dough has raised double in size, it is ready to be made into loaves or baked.

Allow bread to cool uncovered after baking, as covering bread while hot is apt to cause soggy bread. Bread may be dried on the edges of the tins in which it is baked. When the bread is cool, place in an air-tight box or jar to keep from drying.

To make bread brown on top, brush the tops of the loaves over with milk when putting in the oven and brush the loaves with butter a couple of times when baking.

To give a glossy top to rolls brush over with the white of an egg which has been slightly beaten, put back and dry in oven.

Dried bread may be steamed and it becomes almost like fresh bread.

Stale bread can be used for toast; or made into crumbs by drying the bread in the oven, and then putting it through a vegetable grinder or rolling it on a board with a rolling pin.

When grinding stale bread crumbs or crackers in the food chopper,

tie a paper bag on the end of the grinder and snap a rubber band around it. This will prevent getting the crumbs on the floor.

Place **bread crumbs in a covered jar** and they may be used when needed for the tops of escalloped dishes, croquettes, puddings, and as fillings for escalloped dishes, Brown Betty, etc.

Warm bread may be cut with a hot steel knife.

Large round coffee cans make good tins for the baking of bread, especially for bread that is desired for sandwiches.

Cereals

Fine granular cereals may be kept from lumping when hot water is poured over them, by first mixing the cereals in cold water. Stir cereals with a fork. It is best to cook directly over the fire for the first ten minutes and continue cooking over boiling water as in a double boiler. The length of time for cooking depends upon the cereal. Cream of wheat should be cooked 45 minutes. Corn meal and oatmeal should be cooked for three hours. The average length of time for cooking cereals is 45 minutes.

Breakfast foods such as oatmeal, cream of wheat, etc., require a long thorough cooking, they may be cooked the night before in a double boiler, and reheated the next morning.

Fruits, dried or fresh, are an improvement when added to some cereals. Raisins added to the water in which the cereal is to be cooked, make a pleasing variety.

Dates, seeded and quartered, prunes and figs, previously stewed until tender, raisins, or bananas sliced, are all pleasing additions to the breakfast cereal. Besides making it more attractive and palatable they add to the nutritive value. These same dishes make simple and suitable desserts for the children's evening meal.

Left-over cereal may be put into a jar and covered with a small amount of water to be reheated when needed. Or it may be moulded and sliced to fry.

Frying cereal or mush in deep fat will insure a uniform brown crust over the mush, make it less inclined to be grease soaked and easier to digest.

Hot corn-meal mush and milk is palatable, inexpensive and as nutritious as the corn products put up in fancy packages.

Pastry

A little baking powder added to the flour which is used for making pie crusts, will make the pastry much lighter.

Pie crust may be made very flaky by spreading butter over the top of the crust before baking, over this sprinkle a tiny bit of flour and over this dash some cold water. Put into the oven and bake.

Flour and shortening for pie crusts and pastry, may be prepared

weeks before it is needed for use. Put in a jar, cover and set in a cool place. With this preparation, pies may be made in a very few minutes when needed.

Left-over pastry — When making pies if there is sufficient pastry left over, make it into a lower crust. Bake the crust on the outside of the pan then when baked it will fit the inside of the tin. Prick the crust with a fork to prevent air bubbles. Set this crust aside and when preparing a meal in haste, a cream, custard or lemon pie may be made in a few minutes.

Small pieces of pastry may be used for making tarts or cheese straws.

Oleomargarine is equal to butter for cooking and baking and is much cheaper. By using oleomargarine in place of butter, a large item of expense may be cut down.

Pastry flour makes much nicer cakes than bread flour. It is nearly as cheap as bread flour and cakes require a smaller amount of flour when made from pastry flour than when made out of bread flour.

An excellent substitute for pastry flour may be made by adding two tablespoons of cornstarch to each cupful of bread flour. Much lighter cakes and cakes of a finer grain or texture can be made from pastry flour or from cornstarch and flour.

Cakes and Cookies

When making cookies, etc., with lard or unsalted shortening add a little salt and the cookies will taste as if the shortening were butter. Add an extra pinch of salt to cakes to remove the flat taste.

When putting a filling on a cake, if the frosting begins to harden, finish by putting the filling on with a knife dipped out of hot water.

If a boiled frosting has overcooked add a teaspoon or two of butter or cream. It will soften the filling and give it a glazed top.

A white caramel frosting of white sugar and milk can be cooked and set away for several days before using. Beat well before using.

Melt chocolate for a cake or filling by setting in a pan of boiling water, or placing in the steam that comes from the teakettle when the lid is partially removed.

Cook candy or cake fillings until a soft ball can be made or until it forms a thread when dropped from the spoon. Soft ball means that the mixture can be rolled into a ball between the fingers, after being placed in cold water.

When baking loaf cake or fruit cake that takes one hour or more, try placing one pan into another pan of the same size and see how nice and brown the cake comes out. There is space enough between the two pans to keep it from burning. Put a pan over the top also.

Cotton seed oil is a good shortening to use for cakes, etc. It gives the cake a nutty, pleasing flavor. The cake is light, fine grained and soft. Cotton seed oil will be found much cheaper than butter.

Crisco is a vegetable shortening or preparation and a very good substitute for butter or lard in baking.

Chicken fat properly tried out is an excellent substitute for butter.

Hot fat should not be added to a cake batter, as it toughens the cake.

Potato water is a good substitute for sweet milk for cake making. Substitute the potato water for the milk required. It makes a very moist cake and one that does not dry out quickly.

Cake batter to which fruit is added should be a little stiffer than for an ordinary cake.

A chocolate cake becomes stiff and dry if kept in a very cool place.

A little soda added to the chocolate for a chocolate cake will darken the cake.

If a cake is made by putting cocoa in it, in place of chocolate as recipe calls for, the cake will be dry and bready, as chocolate contains more fat than cocoa.

Roll fruit in flour before putting in a cake to keep the fruit from sinking to the bottom of the cake.

Stone raisins by covering with boiling water. When soft squeeze out seeds.

Rich fruit cakes should be baked in a very slow oven.

Molasses can be substituted for sugar in a rich fruit cake. One cup of molasses contains as much sugar as seven-tenths of a cup of sugar.

When spice is added to a cake it should be scalded with boiling water. The water thickens the spice, takes away the raw taste of spice, and gives a rich, dark color to the cake, it also makes the cake moist. Two teaspoons of boiling water should be added to each spoonful of spice.

When nuts are added to a cake the amount of fat to be used in the cake should be decreased, as the nuts contain a large per cent of fat. One to one and one-half tablespoonful less of fat should be used for every cupful of nuts.

Grind nuts by putting through a coarse food grinder. Nut meats that are purchased shelled should be washed and dried in the oven before using.

Flour should be sifted twice, measured, mixed with baking powder, spices added if used, at this time, and sift again.

To keep cake from sticking to the pan, grease the pan with unsalted fat, over this sprinkle flour. If the pan is rusty, line with paper.

If the oven is too hot, cool by placing a dish of cold water in the oven. If it bakes too much on the top, cover with a thick paper.

Allow cake to cool a few minutes after taking from the oven, before attempting to remove from the pan.

A toothpick for testing a cake is much better and more sanitary than a broom straw.

Make baking powder in the home. The cream of tartar and soda

can be purchased at any store. Mix by sifting several times. The proportions are:

$\frac{1}{4}$ pound of cream of tartar.

$\frac{1}{8}$ pound of soda.

1 ounce of cornstarch.

When frying doughnuts care should be taken not to stick the fork into them, as this allows the grease to enter and will cause the doughnuts to be grease soaked.

Fat for frying is hot enough when smoke first comes from the grease. Grease should be hot enough to form an outside crust on the dough at once to prevent the grease from penetrating the food.

In frosting a layer cake, it has been found helpful to pin a strip of glazed paper about an inch higher than the cake around it. This will serve as a retainer when the frosting is poured on the cake. After the frosting has set, remove the strip of paper, using a thin-bladed knife that has been wet in hot water.

Jelly Making

Perfect enamel or granite ware is the best to make jelly in because it is easily cleaned and will neither affect or be affected by fruit juices. Wooden spoons are also best for the same reason.

The necessary utensils for jelly making are tumblers, preserving kettles, colander and cloth or bag for straining.

Select fruit that is not quite ripe. Never take any imperfect fruit.

The best fruits for jelly making are the currant, crab-apple, quince, grape, peach, plum, red and black raspberry.

Wash and clean fruit very rapidly so that it will not absorb water.

Leave skins on the larger fruits. Do not core apples or pears, or stone any fruit.

It is best not to use juicy fruits just after a rain, as they absorb so much water that it is hard to boil them down to make jelly.

Cook large fruits such as apples, peaches and pears in water until soft.

Never stir the fruit while cooking.

To make very clear jelly, strain the juice through several thicknesses of cotton material. Never press juice through the cloth. The pulp left may be put back on the stove, water added to it and allowed to simmer for a few minutes. Then strain this juice again. The fruit may be mashed and squeezed in the kettle for this second extraction. When making jelly, it is well to make two grades of jelly. Have a large jar which will hold about 12 quarts and another large jar that will hold about 8 quarts. In the larger one put in all juice that strains through of itself. In the second jar squeeze the juice through. Tie several thicknesses of cotton over the jars. Boil the fruit until there are several quarts of juice. While doing this have sugar on the stove heating and

jelly glasses on the back of the stove, heating and sterilizing. Measure out the juice and put it in enameled kettles on the stove. Have two or three kettles on the stove cooking at the same time. Heat the juice and add the heated measured sugar to the juice.

The average amount of sugar to juice is $\frac{3}{4}$ cup of sugar to 1 cup of juice. This will vary some with the season. If it has been a hot dry summer, there will be a great deal of sugar in fruits, therefore $\frac{1}{2}$ cup of sugar to 1 cup of juice is sufficient, while if it has been a very wet season, perhaps an even measure of sugar to juice will not be too much. The juice that comes from the second straining will require less sugar as it contains more water. The juice may be heated and some of the water allowed to evaporate, then the same proportion of sugar can be used.

Jelly should be cooked until it breaks off in sheets as a portion of it is allowed to drop from the stirring spoon into the kettle, or until it becomes firm when dropped on a cool dish. Jelly should cook in from 10 to 15 minutes if the sugar is added hot. It should not be allowed to boil rapidly as this causes it to sugar.

If jelly does not stiffen after it has been placed in glass jars, instead of putting it back into the kettle and cooking longer, set the jars in a dripping pan which has been partly filled with warm water, and place all in the oven. Cook until thick enough. Currant jelly may be hardened in the sun.

Jelly must be protected against mould. This may be done by pouring melted sealing wax or paraffin over the top and covering with the covers. Keep in a cool dark place.

The foam or scum that forms on top of jelly should be removed as soon as formed.

The acid from the white inner skins of lemons or oranges may be used to strengthen other fruit juices.

Apple juice may be used as a basis for the fruit jellies.

Beet sugar makes just as nice jelly as cane sugar.

Canning of Fruits

Select well grown, firm, but not over ripe fruit.

There are several types of jars on the market, the jar having a glass cover clamped on with a metal device has given the most general satisfaction.

Use new rubbers every year, as old rubbers lose their elasticity and may cause imperfect sealing. Care should be taken when buying rubbers, not to buy those that are stiff, inelastic and hard.

Test the jars before using by partly filling the jar with water, adjust the cover and rubber, seal and invert the jar. If it leaks examine and find the cause. Testing jars before using will save a great deal of time and give better results. If the can is found to be imperfect save

it for pickles or a food that does not need sealing. Leaking fruit jars are often due to the cover being bent. This may be remedied by straightening the can cover in the places where bent, by placing on a piece of iron or edge of a stone and pounding. The places to be straightened may be marked while testing the can.

After sealing jars of fruit, stand them up on end and if there is a place that is not air-tight, the juice will begin to run at once. The cover may then be screwed on tighter, or perhaps if the cover is bent where it leaks, the leak will be stopped also. Standing the jar this way keeps the rubber from drying out.

When putting fruit into a jar, have a hot cloth around the jar, this prevents cold air from coming in contact with the jar.

Canned fruits should not be stored away until after the cans are tested. It is best to let cans stand for two or three days, then test by loosening the clamp. Grasp the can by the edges of the glass top. If the can is in a perfect condition, the cover will not come off. Tighten the clamp and set away. If the top comes off, take the food out and cook again.

Cover fruit jars with paper sacks when putting away in the cellar and the fruit will have a better color. The sack keeps the light from the fruit and light tends to fade the color of the fruit. The name of the fruit in the can may also be written on the outside of the sack, thus saving time searching for desired fruit.

To open a jar, run a thin knife blade under the rubber and press firmly. If the top resists, pour a stream of hot water over it.

Shelves placed in the cellar make a very convenient place for keeping fruit. Steps made in the stone wall similar to shelves have been found very satisfactory for keeping fruit jars. Narrow shelves that accommodate only one depth of jars make it easy to see just how much and what kind of fruit is on hand.

There are several ways of canning fruits:

1. Putting fruits in water and adding sugar.
2. Adding fruit to a syrup.
3. Putting fruit in a can with a little water, putting on cover and rubber loosely, and steaming by placing in kettle or boiler or by placing in a pan of water in oven. Cook for 30 minutes this way. Remove the can from kettle or oven, take off the rubber and cover, put on a new rubber, pour boiling syrup over fruit and seal hot. Any fruit can be canned by this method and the fruit will be found to possess a fine flavor as none of the juice is allowed to escape.

4. Another method is to put the uncooked fruit in a jar, heat the jar so that a hot syrup may be poured over the fruit without breaking the jar. Seal at once. Fruits are very palatable when put up in this way. Peaches, pears, grapes, plums, rhubarb, tomatoes, cherries,

strawberries, and blackberries are particularly good when put up in this manner.

When fruit is steamed in the jars, a clothes boiler having a wooden rack in the bottom is very useful as it will hold so many cans. The jars should not be allowed to touch one another, and some rack must be placed in the bottom of boiler or kettle, as the jars will break if they are placed on the bottom of the utensil. There are utensils on the market purposely for the canning of fruits by the steaming method which can be purchased for small cost, or a rack may easily be made of wood. When removing the cans from the boiler do not set on a cold surface or they will break. Fruit may also be canned by steaming in a fireless cooker.

Canning Vegetables

Any vegetable may be canned by the steaming method, corn, beans, peas, beets, squash, eggplant, cauliflower, asparagus, etc.

Select young, tender vegetables, gather in the early morning, and keep cool and crisp until used.

The same principles hold for canning vegetables as fruit, and the same utensils can be used. Put the vegetables in cans, cut up into short lengths, dice or slices, depending upon the vegetable, add salt, cover with water and pack well in jars. Put the rubber on the can, put on the cover loosely and set in a boiler filled one-third full of hot water. Bring the water to a boil and boil for one hour. Remove the jar from the boiler, and seal tight. The next day loosen the cover, put into boiler and boil for one hour, then seal as before. The third day repeat the process. Remove from the boiler, put on a new rubber and seal tight. Set away for a few days. Then test as fruit jars were tested. If cover comes off when testing, loosen the cover and cook one hour and a half. A new rubber should be placed on glass jars after steaming and before sealing, as the steaming stretches the rubber. If large cans are used the time for cooking should be lengthened.

Vegetables can be steamed in a fireless cooker.

Canned vegetables will be found very useful and appetizing in the winter time. They can be opened and served in ten minutes.

Miscellaneous Suggestions

Egg whites beat much quicker if a pinch of salt is added to them.

To whip separated cream quickly add a pinch of baking soda.

Eggs may be packed in water glass (sodium silicate) for from three to four months. Proportions, 5 quarts cooled boiled water to one quart water glass. The solution should be of the consistency of molasses; if heavier, dilute it. Eggs may be added to the solution from day to day. Water glass can be purchased at any drug store.

Extract the juice from an onion by cutting a slice from the root end of an onion. Press onion on a grater, working around in a circle.

When cleaning chicken clean the skin by rubbing with moistened soda, then wash in salt water.

If fat has spattered on the stove after boiling or frying, wipe the stove at once with a newspaper.

When spreading hard butter, dip a knife in hot water, wipe off, and spread the butter with the hot knife.

Iced tea makes a very refreshing drink, especially during the summer. Make it weak and serve with lemon juice.

Coffee may be cleared by adding an egg to 1 cup of ground coffee, or by adding a small amount of cold water before serving, or clean eggshells.

When making milk gravy mix the butter and flour with a fork and it will be easier to keep it from lumping.

Ice cream will have a much better flavor if allowed to stand for a couple of hours after freezing.

Rancid butter can be sweetened by washing in lime water and rinsing in cold water.

Keep salt from lumping by adding cornstarch to it. The starch absorbs the moisture.

Lumpy brown sugar can be softened by placing over a pan of boiling water.

When making candy, if the plate that the candy is to be placed upon is wet in cold water directly before using, it will not need to be greased, neither will the candy stick to it.

When bread or cake burn on the bottom try putting a piece of wire screening, cut to fit the bottom of the oven, under the pans.

Cornstarch is a very good agent for thickening soups, gravies, or sauces, as it makes a smoother gravy than when flour is used; only one-half as much starch is required as flour to thicken the same amount.

Salad dressings may be cooked and placed in airtight jars and kept until needed.

If salad dressing or boiled custard curdles beat it well with an egg beater and it will be restored to a creamy consistency.

The green or dark spots on potatoes or vegetables should be removed, as they give a bad flavor to the vegetables that are cooked. The spots are caused by sunburn.

Soften hard water for cooking, by adding soda ($\frac{1}{2}$ teaspoon to 2 quarts of water).

Put vegetables into boiling water to aid in the cooking of the starch, and season when nearly tender.

If a little soda is added to the water in which vegetables, meat or fruits are cooked, the cooking process will be hastened.

Polish kitchen knives and forks by rubbing them with a moistened cork, dipped into ashes or bath brick.

Silver may be cleaned and polished by immersing in the following solution: 1 gallon of water, 1 teaspoon salt, and 1 tablespoon of baking powder. Put this solution in a new tin or aluminum pan or pail, place the silver in the solution, cover, and place on the back of the stove for a few hours. Remove silver, wipe and put away. Silver may be cleaned by powdered chalk. Sift it several times, moisten the chalk with ammonia or alcohol, apply with a soft cloth. On the deeply carved silver use a soft brush.

Clean brass, nickel and copper with powdered pumice stone wet with ammonia. Apply this paste and when dry polish with a flannel cloth.

New ironware may be rendered usable by putting a mixture of lye and potato peeling in the kettle and boiling for from two to three hours.

Paint that has dried on glass may be removed with turpentine, baking soda or hot vinegar.

The oil of an orange peel will remove paint or varnish from the hands.

New tinware can be kept from rusting by rubbing it with fresh lard and heating thoroughly before it is used.

It is best to keep all kitchen knives out of dish water, no matter how the handle is made. Wash by holding in one hand while washing the blade with the other.

Lamp chimneys, jars and tumblers may be toughened by putting them into cold water, heating gradually to the boiling point. Boil for a few minutes, then let cool gradually.

Salt rubbed on lamp chimneys after washing gives them a surprising brilliancy.

If any utensils are not to be used for a time, apply a coating of grease, such as vaseline, paraffin or unsalted fat. The grease prevents rusting.

The separator. A great deal of time will be saved when washing the cream separator if before it is taken apart in the morning, cold water is run through it, followed by some hot water. Do this the night before, after the milk has been separated.

Do not wipe the separator, milk can or pail in the summer time. Scald and turn them up to dry on a table in the sun. Throw mosquito netting over milk dishes to keep the flies from them. When dry pile them up.

When washing dishes lay a thick towel or several thicknesses of cloth on the table that dishes are washed on. Wash cups, rinse in hot water and place on the cloth to drain. Wash the saucers and when they are ready to place on cloth, the cups will be dry enough to put away. This lessens the time required for dish washing a great deal.

When washing very greasy dishes drop a couple of tablespoons of soda in the dish water.

Glass bottles may be cleaned with broken eggshells and hot soap-suds; shake violently.

Borax, soda or ammonia will clean hair brushes well. Rinse in cold water and dry in the sunshine.

Fly specks may be removed from gilt frames by wiping with a solution made by dissolving four tablespoonfuls of borax in one cup of water.

Vinegar will remove glue from fabrics or furniture.

Keep your groceries in tins. Paper bags are made of rags, lime and glue, mixed with chemicals and acids. When dry, these can do no harm, but if allowed to become damp, they are unfit to touch food. Turn everything possible into cans, jars or crocks.

Before papering white-washed or calcimined walls, brush the walls with vinegar, and later with a solution of glue made by adding water to powdered glue.

Ants may be kept from a cupboard that stands on legs by placing each leg in a pan of water. Be sure to move the cupboard away from the wall several inches.

To do away with rats and mice smear liquid tar around the holes, and blow unslaked lime into the holes.

Oil hardwood floors with the following: Boil 3 pints of linseed oil, cool slightly, add 1 pint turpentine and beat well. Boiled oil may be put on floors clear but turpentine hastens the drying process.

Wipe varnished surfaces with a woolen cloth dampened in water, then wipe with cloth wet in kerosene and polish with a dry woolen cloth. N. B.—Be sure to hang oil-soaked cloths in the open air to avoid fire.

To prevent a rug from rolling up, sew on the underside of the rug a piece of stiff buckram, or stiffening, very tightly.

Test a new broom by pressing the edges against the floor; if the straw bristles out and bends, the broom is a poor one. If the broom is good the bristles will remain in a solid, firm mass.

When sweeping, use alternate sides and corners of the broom, so that it may wear evenly.

If brooms are wet in hot soapy water when new and hung to dry, they will wear much longer. Tie strands of a new broom together and soak in boiling water for two hours to lengthen its usefulness.

Dry mops should be washed and scalded on wash day, rinsed and hung outside to dry.

Before sweeping carpets, sprinkle with wet tea leaves, wet pieces of newspaper, or wet sawdust. After sweeping brighten by wiping with a cloth wrung out of a solution of ammonia and water.

Creaking doors, windows, casters, etc., may be prevented by rubbing with hard soap.

Straighten paper, books, chairs, etc. in the living room the night before so that the next morning the living room is in order.

Mailing tubes make a convenient receptacle for the mailing of flowers; roll them in a tissue paper that will just fit inside of tube and sprinkle with water.

Try heating the irons in the oven when getting a meal if ironing is to be done and the top of the stove is full.

Clean the carpet sweeper from thread and hair by removing the brush and dusting with a small wire hairbrush.

Use brass thumb tacks for tacking down oilcloth, etc. The cloth is not torn, neither are the fingers bruised.

If the cap for gasoline or kerosene can has been lost, put a potato on the spout.

Set plants on a piece of window glass cut the desired size, to prevent discoloration and rotting of window sills.

Emergency tack puller. An old kitchen tablespoon makes an excellent tack puller. It has a sharp edge which will get under any tack and it works better than any tack puller.

Soften leather in high boots and gauntlet gloves and make waterproof by the use of plain mutton tallow. Apply hot and rub in well with the fingers.

Vinegar is one of the best cleaners for dirty furniture.

When painting an object overhead, to prevent the liquid from running down the handle onto the hands of the painter, try tacking two pieces of tin on either side of the brush, below the bristles.

Patent leather shoes should be kept in a warm place when they are not worn. Also at this time keep them greased with vaseline.

A very good hand lotion can be made by adding a few drops of lemon juice, rose water and camphor to glycerine. Add enough to thin the glycerine.

To polish nickel, take a pan of soft water and a bar of best white soap. Wash the nickel perfectly clean, then wring out your cloth, apply soap till the cloth is well lathered and rub each piece thoroughly. Polish first with a dry cloth, then with tissue paper.

Radishes may be pulled late in the fall and packed in dirt in the cellar. Leave the stems on. Radishes packed in this way will keep fresh for weeks. Carrots and beets keep hard and fresh when packed this way also.

Tomato vines that have green tomatoes on them may be taken up before the frost and allowed to hang in a dry cellar to ripen. This will furnish fresh tomatoes many weeks after the frost.

To be sure that there are no worms in dirt, that you wish to put

seeds or plants into, bake the dirt in an oven until thoroughly heated through. Remove, cool, moisten and it is ready to use.

Fruit should be packed in cool, dark, dry places where it can be examined often, as decay spreads rapidly from the decayed fruit to the perfect.

Plant a seed of a grape fruit after soaking for half a day and as a result have a very pretty fern.

CHAPTER II

LABOR-SAVING DEVICES

FIRELESS COOKERS—VACUUM CLEANERS—DISHWASHING MACHINES—KITCHEN CABINET BREAD MIXER—CAKE MIXER—STEAM COOKER—FOOD CHOPPER—CASSEROLE—GASOLINE AND OIL STOVES—DOUBLE COOKERS—APPLE CORERS AND PARERS—STRAWBERRY HULLERS—HOT PAN LIFTER—COOKIE CUTTER—COFFEE PERCOLATORS—SLICERS—STONERS—STRAINER-HOLDER—PASTRY FORK—FRUIT PRESS—CLOTHES-HORSE—CHAIRS AND BENCHES—MOPS AND DUSTERS—MISCELLANEOUS DEVICES AND METHODS.

A **fireless cooker** saves fuel and time besides conserving all the flavor and nutriment of the food cooked. Its use permits the housekeeper to prepare the substantial part of the meal, hours ahead of the time it will be needed, put it in a cooker and forget it until the meal time. There is no

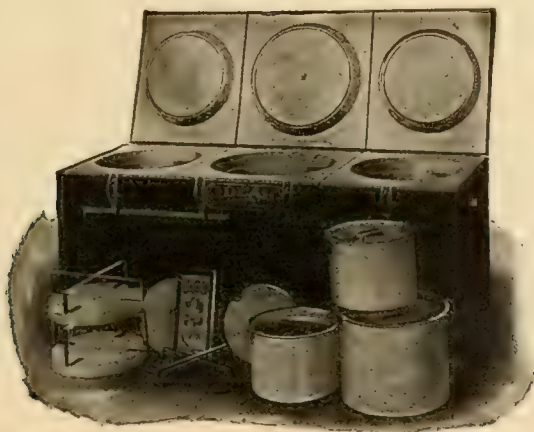

Fig. 1.—The Bench Type of Fireless Cooker.

danger of burning, boiling over, or boiling dry, and no fire to keep going. The housekeeper is free to go visiting, shopping or to spend the time at other duties.

Food to be cooked in a fireless cooker is prepared in the usual manner, seasoned, and put over the fire to start the cooking. The soapstone or metal radiator should be heating at the same time. When the food has been heated at the boiling point 15 to 20 minutes it is removed to the cooker, the radiator being put in first, and the cooker quickly clamped shut. The radiator is hot enough if it hisses when touched with a wet finger tip.

There are many good makes of fireless cookers now on the market. Naturally they give a little better result than a home-made cooker because of their better construction, better packing material and specially fitted utensils. The best models are fitted with valves which permit the escape of excess steam and prevent water from condensing in the cooker.

A book of instructions and recipes is usually given with a commercial cooker which will enable the inexperienced to use it quite successfully.



Fig. 2.—A Home-Made Fireless Cooker.

A fireless cooker may be made at home at a very small expense. A box from the grocer's, an old trunk or window seat, a cheese box or a tight barrel will serve very well for the outside. A large agate, granite or wooden pail can also be used. A cooker may be made to cook one, two or three things at the same time, depending upon its size. In the cheese box there will be room for only one kettle, in the trunk you could probably place three. Select these kettles that are to contain the food carefully. They must be of agate or aluminum with covers that fit tightly. Probably the least expensive and most convenient receptacles are covered agate pails, which can be bought in any size.

Look about the farm for some material to use for the packing. Hay or newspapers will do. Wool, sawdust, excelsior or feathers will also serve very well. Cover the bottom of the box with a layer of the packing at least 4 inches thick. Pack it down very solidly. If newspapers are used, they must be crushed and twisted very tightly, leaving no air spaces between them.

Now make casings for the sides of the pails out of asbestos or newspaper, cutting them to fit and tacking them together with a needle and thread. These casings must fit well but not so tightly that the pail cannot be drawn out of the casing. Set the pail or pails, wrapped in their casings, on top of the layer of packing. There should be a space of 5 inches between each pail and the walls of the box, and the same distance between the pails. With the pails in the box, fill the space around them with the packing. Squeeze in just as much as you can get, up to a level even with the top of the pails. The tighter the cooker is packed the better it will hold the heat and the more satisfactory it will be. When you are sure that no more can be pressed in (it will hold much more than you would believe) pull the pails out of their casings. These will now serve as solid walls to hold the packing in place, and the pails may be set in and out at will. Rounds of newspapers or asbestos cut the size of the pails and placed in the bottom of the nest, will help to conserve the heat. Now a pad must be made to fit the top of the box and fill the space between the pails and the cover. Bed ticking or any strong clean material, filled with wool, hay or cotton will serve for this. Be sure that it is sufficiently thick.

Fireless cookers have been greatly improved by the addition of plates or radiators made of soapstone or iron. These may be obtained the size of the bottom of the pails. These plates are heated piping hot and put in the cooker under the pails, and over it also when baking is to be done. They should not be used in home-made cookers unless protected by asbestos.

Wire stands placed in a large pail will make possible the cooking of more than one food at the same time by placing the wire stand over one dish and another dish on the stand.

Cereals, meats, stews, puddings and all food which require long, slow cooking are most suitable for cooking in the fireless cooker. All foods should be heated to the boiling point before putting in the cooker. It is sometimes necessary to reheat foods before using when they have been in the cooker over night or for several hours.

Triple kettles for fireless cookers. The last thing toward making the equipment of fireless cookers perfect is a set of seamless, aluminum kettles that will "nest" snugly in one compartment of the cooker. This set is a means of cooking several things at one time in one compartment in any make of fireless cooker.

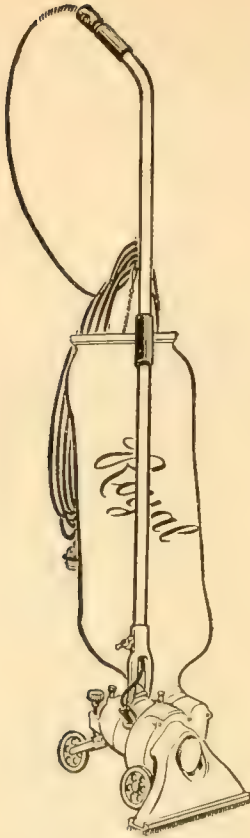

Fig. 3.—Electric Vacuum Cleaner



Fig. 4.—Hand Power Vacuum Sweeper.

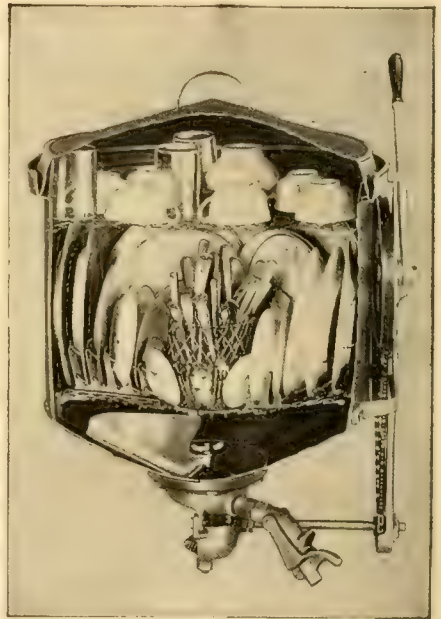

Fig. 5.—Dishwashing Machine (hand power), showing dishes in the container while being washed.



Fig. 6.—A well-planned Kitchen Cabinet.

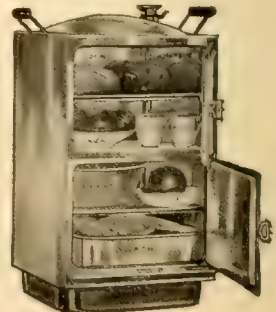

Fig. 7.—Steam Cooker.

The kettles are also splendid for using over one burner of a gas or oil stove. They fit together with mathematical accuracy and not one of the kettles has a seam, joint or break.

Each kettle has capacity for two quarts, and the three together are nine inches and a half in diameter. They afford additional economy to the cooker, as the same radiators will do the cooking for all three kettles.

There are many varieties of vacuum cleaners on the market. They are all good, not very costly and have marked advantages over the broom and dust cloth. With a vacuum cleaner the furniture does not have to be moved when a room is cleaned, also the dusting is lessened to some extent.

If there is a gasoline engine on the farm, a power cleaner may be run by that. One that has not seen how much dirt and dust the cleaner can remove will be surprised when cleaning out the vacuum cleaner. Curtains, portieres, rugs and upholstery can be cleaned with the vacuum, and some have attachments so that walls, etc., can be cleaned with them.

The hand-power vacuum cleaner is more tiresome to operate than the power vacuum cleaner, but removes dirt and dust that will remain untouched by a broom.

There are several dish-washing machines on the market. In a well planned machine, the crank is turned first in one direction and then in another which sprays the dishes with water on all sides. It is turned for two minutes then the wash water is drained off, the rinse water is put in, and the crank turned a minute. This water drained off, more hot water is added and drained. The cover is then left up and the dishes dry in a short time and are ready to put away.

A kitchen cabinet is an advisable investment for any woman. In it all utensils may be kept, as well as all flour, sugar and ingredients needed in baking and cooking. The dishes and supplies are covered and away from the dust. To it is also attached a work table. The work table will be found to give better service if it is covered with thick glass or a metal top.

There should be a bread mixer in every household. It saves time, labor and is more sanitary than when the hands come in contact with the bread. It is a thorough worker, making the results of the bread more certain than when made with the hands. It is easily cleaned and the sponge can be mixed in the pail, and then stiffened or made into a hard dough with the mixer.

The best bread mixer on the market consists of a heavy tin pail with a cover. The pail is clamped to the table. The kneader is a curved metal rod connected with handle. A few turns of the handle kneed the dough thoroughly. The largest size will hold about 10 loaves of bread when light and ready to be made into loaves.

Cake mixers are very useful in a home where there is a great deal of cake baking to be done. Put all ingredients into the mixer and mix by turning the handle for about 5 minutes. The shortening must be soft to

prevent it from coating the flour. It beats the batter very rapidly and makes it light and smooth.

With the use of steam cookers, a large meal can be prepared on a gasoline, kerosene, or gas stove by using only one burner. This is especially convenient on a hot day. You can cook sauer kraut, onions, cabbage and pudding at the same time without any of them partaking of the odor or flavor of the others.

A food chopper is very easily cleaned, adjusted and operated. It is very useful in preparing meats, vegetables, hash, mince meats, chopped

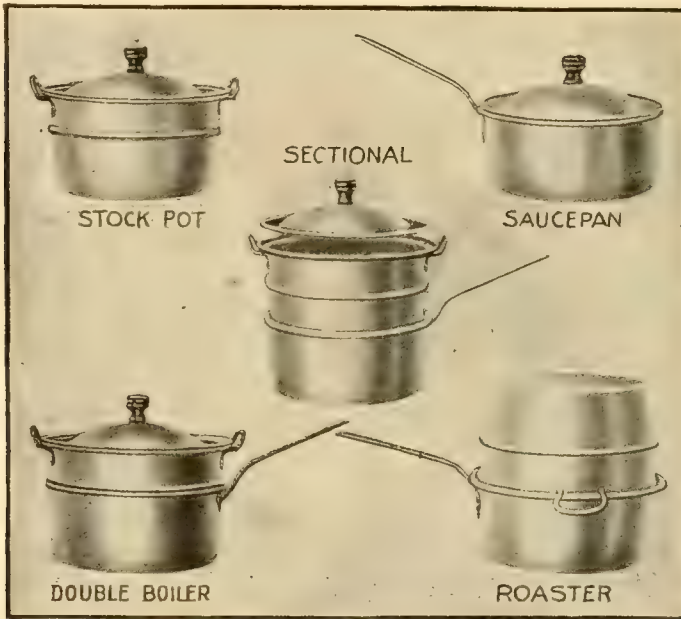

Fig. 10.—Combination Cooker.

pickles, grinding bread crumbs, etc. The grinders may be so arranged as to cut the foods coarse, fine or pulverized.

A **casserole**, or earthen baking dish, may be purchased for a small sum, and will be found very useful for baking meats, beans, macaroni, puddings, etc. in the oven. With the use of a casserole the washing of an extra dish is saved as the food may be served at the table in the same dish. The food may be warmed over in the casserole for another meal.

A **gasoline or oil stove** for use in the summer time is unsurpassed for use on a farm. They can be purchased for a small cost and there are many good makes on the market. They are fine for baking as well as cooking. In the fall or winter time, or when not in use, the oven may be used as a cupboard for storing foods. While if a paper is spread over the other part of stove, it can be used as a table.

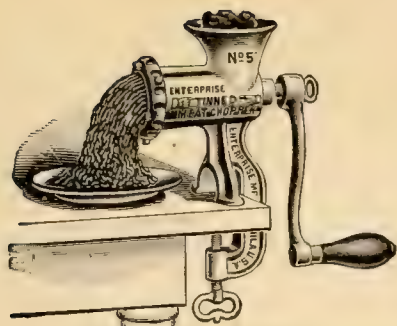

Fig. 8.—Food Chopper.



Fig. 10.—A Double Boiler of good shape.

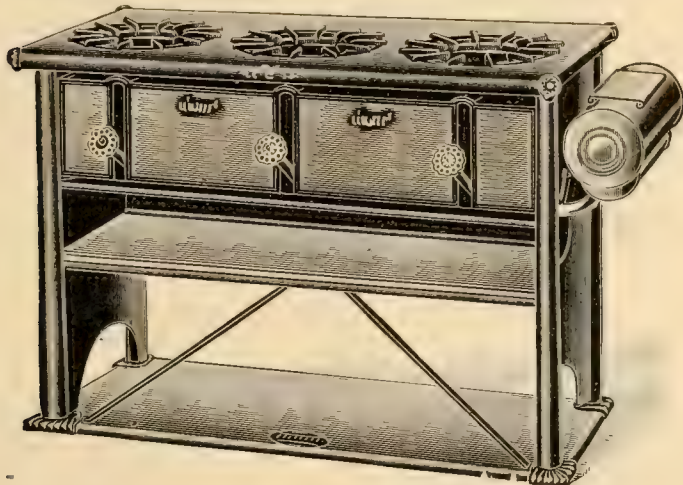
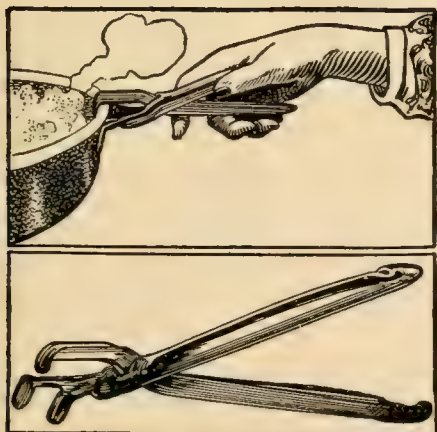

Fig. 9.—Oil Cook Stove.



Figs. 11 and 12.—A Hot Pan Lifter.

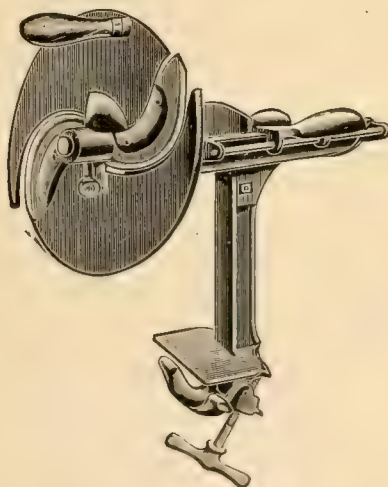

Fig. 13.—A Vegetable and Fruit Slicer.

Double vegetable cookers—These consist of a perforated saucepan set inside of a regular saucepan which is a trifle larger and contains boiling water. The inner dish has a partition through the middle which separates one vegetable from another.

Double cookers save fuel, time, dish washing, and prevent burning. Two vegetables may be cooked at the same time over one burner. They are not expensive and are very useful, especially for a small family.

Double boilers are very convenient for cooking cereals, salad dressings, custards and puddings. The bottom pan is filled one-third full of hot water. There is no danger of food burning in a double boiler.

Apple parers, peach parers and potato parers are some of the greatest labor-saving devices on the market. They can be purchased at a low cost.

Apple corers, pineapple and potato eyers are very handy devices to use when preparing apples, canning pineapple, etc. They cost but a few cents and prevent a needless waste.

Strawberry hullers are most useful during the strawberry season. The flesh under the thumb nail often becomes raw and sore from picking over berries. With the huller this is avoided, strawberries may be hulled faster than by hand, and kept in better shape.

A hot pan lifter will protect the hands of the housewife when removing a cake or any hot dish from the back of the oven or from the top of the stove. The lifter is similar to a pair of tweezers and can be purchased at any hardware store.

A cake and doughnut cutter can be purchased that will cut out any number of cookies and doughnuts in one stroke, if the dough is rolled out evenly.

Coffee percolators are not expensive and the coffee made with a percolator is free from grounds, of a perfect flavor and needs no eggs. The cuplike percolator which contains the coffee grounds can be bought separately and put in any ordinary coffee pot. Attached to it are metal pieces which can be bent to suit the sides of the pot, and these hold the percolator firmly in place.

An egg and beet slicer has been put on the market that is very useful. It makes even, uniform slices, and a whole egg or beet can be sliced with the same movement it would take to cut a single slice by hand. It is equally good for slicing carrots, potatoes or turnips.

A bread slicer. When desiring to have bread cut thin and very even, the bread slicer cannot be excelled.

A vegetable or fruit slicer will be found to be one of the greatest time-saving articles that is made for the kitchen for slicing cold slaw, saratoga chips, French fried potatoes and many other vegetables and fruits.

There are various good devices on the market for stoning cherries and seeding grapes and raisins that can be had at slight cost.

A **strainer-holder** consists of a six-inch ring for holding the straining-bag, mounted upon a jointed rod sixteen inches high. The straining-bag is made of unbleached cloth and may easily be removed from the ring for cleaning. Jellies, crushed fruits and many other foods may be strained without attention, as there is no need to stand and hold the strainer above the basin. The device can be taken apart and packed in a small space.

The **pastry fork** is made with four sharp blades which cut the shortening into the flour when making pie crust or biscuits. Small particles of shortening are thus formed and coated with flour. When quickly worked together with as little water as possible flaky pastry is insured. The hands are not used until the dough is ready to be rolled out. The fork can be used in cutting up strawberries for shortcake, raisins, nuts, vegetables, etc.

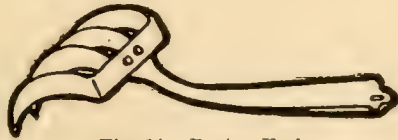

Fig. 14.—Pastry Fork.

A **press for making jelly, jam, butter, etc.**, presses the fruit through the colander and the hands do not have to come in contact with the hot juice. It can be used to mash potatoes, vegetables, sift flour, sugar, etc., as it has sieves of different sizes.

There is a **clothes-horse** that is as easily carried about as a mending basket, with twelve strong out-spreading arms thirty-two inches long. It may be lowered within five feet of the floor, and then, to have the snowy clothes well out of the way and yet air a little longer, it can be raised to nine feet in height. With the clothes removed, the hanger closes like an umbrella and can be stored away in a very small place. This device is excellent for drying clothes in the house on stormy days.

A **bench**, of fine white wood, made after an old Dutch style, has found great favor with housewives who are making their housework more tempting. It is an inviting seat for use on the kitchen porch at any time and the sturdy back has a double purpose. Whenever it is wanted it can be turned into an ironing board, or a table.

A **straight backed kitchen chair** that can be made into a step ladder at a moment's notice, is very useful for washing windows, reaching high shelves in pantry and for general use in, and about the house.

A chair should be placed near the work table where one may sit when peeling potatoes or doing any work which does not require stand-

ing. A high stool is liked by some and much work such as dish-washing, ironing, etc., can be done while sitting.

Another useful chair for the kitchen is one that has a seat that lifts up. In it may be kept shoe blacking supplies.

There are several self-wringing mops on the market. As they do away with the most disagreeable part of mopping, any housewife who has much of this work to do should own one.

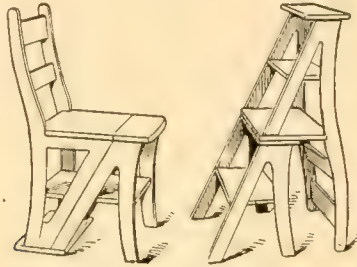

Fig. 15.—Combination Chair and Stepladder

Oil dust mops and a dustless duster are very necessary articles in the home. The dustless dust cloth polishes glass and wood work. A piece of cloth put over the broom and a dustless cloth over this is



Fig. 16
Self-Wringing
Mop

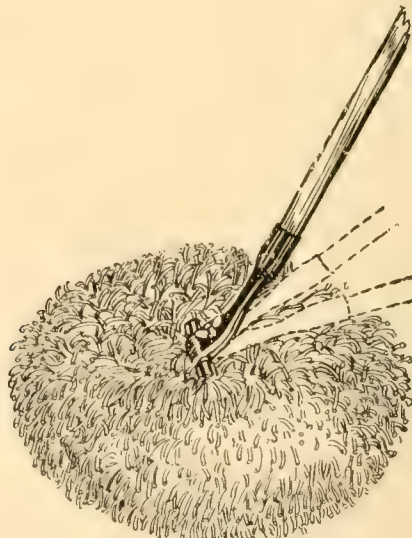

Fig. 17.—Oil Dust Mop

excellent for cleaning ceilings. The oil dust mop is treated with some oily substance and has the power of holding dust, thus preventing the dust from flying about the room.

Dust is full of impurities and to stir it up with broom and feather duster is a menace to health and cleanliness.

Miscellaneous Household Devices and Methods

A convenient, useful, and attractive buffet for the dining room may be made from a plain unvarnished kitchen table, on which is placed the adjustable top of a kitchen cabinet. By selecting one of the tops which has doors with latticed panes, and painting it attractively, one may have a combination bookcase and writing table.

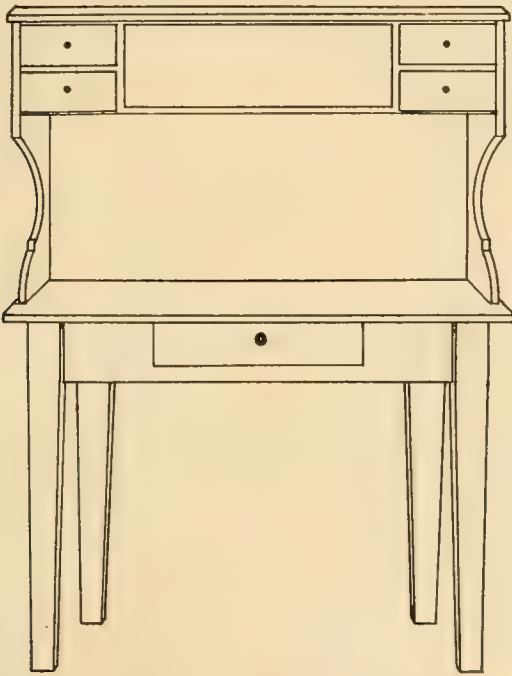

Fig. 18.—Home-Made Buffet

Cookies are best baked on iron sheets cut to fit the oven, with heavy tin sheets as second choice. The sheets are kept in better condition if, instead of being greased, they are warmed and rubbed lightly with paraffin. The process of baking cookies is shortened greatly by the use of these baking sheets as so many cookies can be baked at one time.

A **spatula or palette knife** (a thin flexible bladed knife) will completely remove all batters and doughs from the mixing bowls, thus making dishwashing easier and preventing a waste of the dough.

Wooden spoons are especially desirable in the kitchen. They are light and noiseless. They neither affect nor are affected by any juice, and

do not scratch metal surfaces. Enamel spoons bend easily, thus the metal cracks and chips off and pieces may fall into the food.

To grease tins for bread, rolls, etc., use small brushes about 1¼ inches wide by 1¾ inches long. This avoids greasing by hands.

To clean vegetables, small wooden-backed brushes are good. They can also be used to remove the grated lemon rind from the grater and to remove the silk from sweet corn.

A glass or tin measuring cup is very valuable for measuring different ingredients accurately. All measurements are indicated on the outside of the cup.

Paper may be put to many uses in the kitchen. Heavy absorbent brown paper is excellent for draining doughnuts and croquettes on. Wet paper makes a good stove cleaner.

Pound coffee cans make very good tins for baking bread, steaming puddings and brown bread.

Save time in churning by buying a dairy thermometer and always be sure that the cream is of the right temperature before making butter.

A deep wire frying basket to hold the articles to be fried is very convenient. It may be hung on a long handled fork and lowered and raised by this also.

For deep fat frying, use an iron or steel kettle having straight sides. It accommodates more articles in the kettle and a wire frying basket will fit this shaped kettle better.

A cake board and a bread board are very handy for slicing on and can easily be made at home from a clean piece of board. It is best to put a hole in one end, so that they may be hung up when not in use.

Bread pans with drop sides are very convenient, as the cake or bread can be left in the tin and cut there. There is an air space underneath the bottom of the pan so that the food will not burn.

Do not use dull knives and scissors, when with a knife sharpener they may be sharpened in a moment.

Lemon and orange squeezers prevent juice being lost and save time in squeezing lemons and oranges. The seeds are separated at the same operation and held in the saucer of the squeezer.

An assortment of covers for any size kettle, with a wire rack to hold them, will be found most useful in the kitchen.

Every housewife should have a sectional or ring lid for the kitchen stove. This lid is in three sections and allows for three sizes of pans to be used on it directly over the fire.

Cake tins with removable bottom will be found very convenient in which to bake cakes.

Granite pie tins are much better than tin. Pies baked in tin will taste of the tin if allowed to stand in them.

A very convenient rack for the holding of pans. Any size pan will fit this rack and the pan that is desired may be taken without disturbing the other pans. A rack like this can be made at home in a few minutes and will be found very useful.

When buying frying and sauce pans it is wise to buy pans that have lips on both sides, or at least that have the lip on the side that will be convenient for the user. Most pans on the market have the lips on the side convenient for a left-handed person. This pan is inconvenient for a right-handed person to use.



FIG. 19.—Home-Made Pan Rack

A soap shaker is very useful for utilizing scraps of soap. Put the soap in the shaker and use by beating the shaker back and forth in the water.

Old flour sifters can be used to boil eggs in. Place the eggs in the sifter and stand in water. When cooked, the sifter may be lifted out and the eggs will be drained.

Keep cans of pepper and salt on the kitchen stove and save a few steps.

Large tin covers off of lard pails make good tins for the baking of layer cakes. If knobs are put on the covers they make good covers for kettles, etc.

A cart on which is placed a tray is very convenient and saves many steps. Wheel the food from the kitchen to the dining room. It saves many steps. A baby carriage may be remodeled and used for this purpose.

A good place for drying towels may be made by fastening two brackets lengthwise on the back of a door and nailing a narrow board on the bracket crosswise of the door.



Fig. 20.—Tool Rack for Kitchen

A tool rack for the kitchen may be made from an ordinary wooden box, painted inside and out, and fitted with handy tools. Compartments at the bottom should contain different size nails, screws and tacks.

Brackets for a roller towel may be made from common wire clothes hooks by inserting a piece of wood in the rounding part of the hook. A small rolling pin sharpened at each end, or a piece of broom stick will make a roller for the towel. To remove the roller the hooks are sprung apart enough to allow it to drop out.

Foot Warmer. When taking long rides in the winter time nothing will give so much comfort to the people riding as some kind of a foot warmer. Carbon brick heaters are not expensive and are very satisfactory.

A **baby screen** with all the baby's clothes and toilet articles on it is very convenient when giving the baby a bath. All the necessary supplies can be in handy pockets on the inside of the screen, or hung from the top frame of the screen on brass hooks.

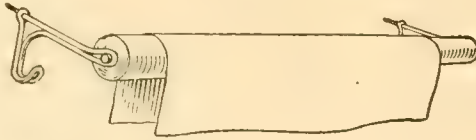

Fig. 21.—Simple device for a Towel Roller

The **bottom steps in the stairs** can easily be made a handy receptacle for rubbers, tools or children's playthings if made so that the top board is on hinges, or will slide out.

A **large scrubbing brush** turned upside down and nailed to the floor of the back porch makes an excellent shoe cleaner.

A **long-handled hooded dustpan** is now made which prevents stooping when gathering up the dust.

CHAPTER III

LAUNDRY-SAVING DEVICES

GASOLINE ENGINE—POWER WASHING MACHINES—HAND WASHERS—BOILERS—FLATIRONS
—MANGLES—IRONING BOARDS—HOME-MADE SOAP—SPECIAL INSTRUCTIONS FOR
REMOVING STAINS—LAUNDRY HELPS.

Have a separate room for the laundry, if possible, a room in which there is running water and all necessary supplies.

Small gasoline engines are very satisfactory for running the washing machine, pumping water, churning, turning the cream separator. A small gasoline engine can be obtained for a very reasonable price, and will pay for itself in a short time. Every woman on a farm should have the use of one. Until one has been used in and about the home it cannot be appreciated.

Power washing machines. There are many makes on the market and though they vary some in construction, they are all very satisfactory. The machines have a wringer attached, which is also run by machinery.

With this kind of a washer the clothes may be washed, rinsed, and wrung by the machine. It is only necessary to starch and hang up clothes by hand. Plenty of warm water and soap must be used. Turn the clothes while they are being washed. It is not necessary that the machine be watched continually as it may be left for several minutes at a time, thus one may be doing the housework and washing at the same time. If it is impossible to have a power washer, at least have a hand washing machine, as they are far ahead of the wash board.

There is a hand washer on the market that is especially good for the washing of comforters, quilts, sweaters, carpets, thin materials, etc. These articles should never be washed in a power washer, as they are too heavy and are liable to break the revolving center of the washer. The principle of this washer is suction. They are effective and inexpensive. With this washer there is no danger of the clothes being torn or worn by washing.

When buying a boiler, it will pay to buy a good boiler with a copper bottom and with care it will last for years. Wash and dry it well after each using.

A square clothes stick will be more satisfactory than a round one as the clothes cannot turn on it as on a round one.

Flat Irons. The old irons that have been used for years are the best kind of irons available. Irons should not be too heavy as heavy irons

are very hard to iron with. It is best to have irons of various weights. A very heavy one for pressing, lighter ones for ordinary ironing, and a narrow pointed one for ironing sleeves and fine work.

Your iron will not stick if you do one of two things: (1) Add 1 tablespoonful of salt to $\frac{1}{2}$ gallon of starch; or (2) 1 tablespoonful of kerosene oil put into the cold starch. These give a pretty gloss.

Denatured alcohol and gasoline irons are very convenient and useful. They are not expensive to use and make ironing much easier, especially during the hot weather when ironing is a task.

Mangles—There are two kinds of mangles on the market, the cold roll ironing machine and the hot roll ironing machine. Both are very

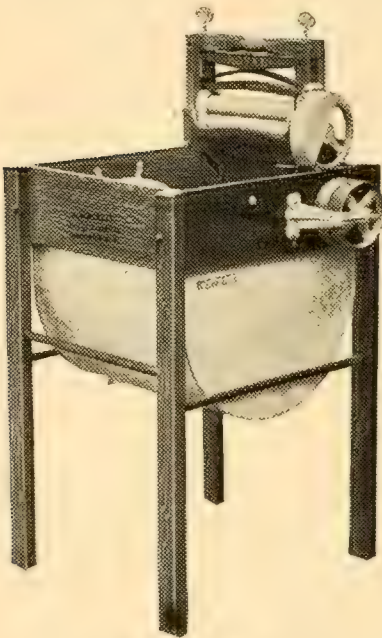

Fig. 1.—Power Washing Machine

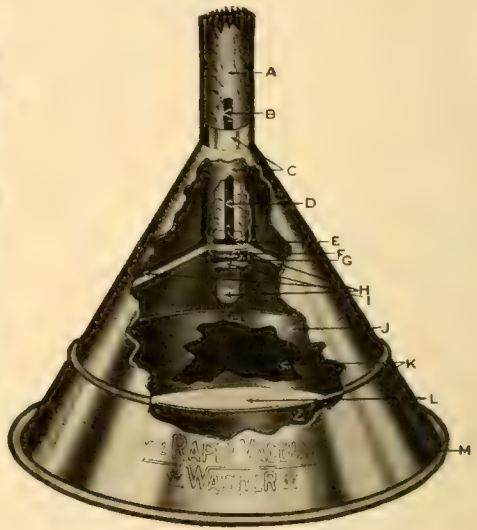

Fig. 2.—Hand Washer

satisfactory. They can be operated by hand or power. They are very good for ironing all flat pieces such as sheets, pillow slips, towels, table cloths, napkins, handkerchiefs, and the like.

Ironing Boards—These should be about 14 inches wide at the widest end and should slope down to about 8 inches at the other end, the ends should be rounding. Pad the board well, tack on tightly and cover with cloths that can be tied on.

The ironing board can be fastened to a stand or it can be attached to the wall. Care must be taken to place where the light is good. In new houses, ironing boards are very conveniently built in the wall

A sleeve board can be made in a very few minutes and will be found very useful for the ironing of sleeves, small yokes and dresses.

Home-made Soap — During winter, ham, pork, bacon and other meats which yield a great deal of fat, are used more freely than in the warm weather. The careful housewife should see to it that not a scrap of the fat is thrown away or wasted. To be sure some of it may be used to advantage in making gravies and sauteing vegetables; but in almost every household there is a tendency to throw away the fat as quickly as possible. Instead of practising this extravagance, strain the fat and put it into a covered pail or can. When you have three or four pounds, make it up into soap.

The fat should be free from impurities. A simple way of bringing about this result is to put the fat into a kettle with a little water; set on the stove or in the oven; the impurities will sink to the bottom of the kettle; the fat will come to the surface, and, when cold, may be taken out in a single cake. Weigh the fat carefully. Take this clarified fat, put it into a pail or kettle and set it where it will melt.

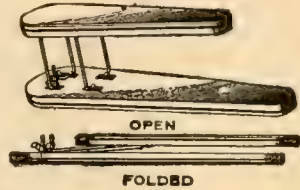

Fig. 3—Folding Sleeve Board

Into a good-sized crock or can put a can of lye for every 5 pounds of fat. Add to this lye 5 quarts of water and 2 tablespoonfuls of borax, stirring constantly until the mixture stops boiling—the fat is not put on the stove. When cool, stir in the fat slowly, and when the mixture has begun to thicken, pour into pans or pasteboard box covers. Mark off into squares before it hardens.

If soft soap for laundry purposes is desired, increase the quantity of water, using at least three times as much; keep this soap in a covered crock.

Home-made soap of this kind will make rich white suds; there need be no fear of using it when washing laces, blankets, or the daintiest of lingerie, for it will not harm the most delicate of fabrics.

If one wishes the soap for toilet purposes, it may be scented by adding a little violet, rose or other essence.

Special Instructions for Removing Stains

The process of removing stains is fundamentally the same as that of removing other forms of dirt, that is to find some substance in which the stain is soluble or which will aid in its mechanical removal. The chief solvents valuable in removing stains that resist ordinary washing processes are:

- | | |
|---|--|
| Turpentine (inflammable) | Benzol |
| Benzine, naphtha, or gasoline (inflammable) | Hydrogen peroxide |
| Carbena | Sunshine |
| Kerosene (inflammable) | Ammonia |
| Ether (inflammable and an anæsthetic) | Borax |
| Chloroform (an anæsthetic and a poison) | Salt |
| Alcohol (inflammable) | Vinegar |
| Olive oil, lard, etc. | Lemon juice |
| Fuller's earth and French chalk | Hydrochloric acid (a strong acid very corrosive to fabrics and to flesh) |
| Naphtha soaps | Ink eradicator |
| Water, both hot and cold | Milk |
| Oxalic acid (a poison) | |
| Javelle water | |

Cold water will not affect any stain and may remove some that hot water would set.

Grass stains—

1. For non-washable materials use alcohol.
2. Butter and salt applied.
3. Paste of soap and baking powder.
4. Molasses rubbed in and allowed to stand over night.
5. When the color is not delicate use ammonia and water.
6. Spread with lard; let stand a short time, and then wash with soap and water.

For Grease and oil—

1. Put powdered chalk or brown paper over the spot, then press with a hot iron.
2. Gasoline and flour made into a paste.
3. Alcohol and salt (applied with a sponge or flannel cloth, 4 teaspoonfuls of alcohol to 1 teaspoonful of salt).

When the goods cannot be washed use gasoline. Put folds of cloth under the spot and rub towards the center of stain.

For silk — Wet magnesium, let dry and brush off.

Vaseline — Soak in kerosene and wash.

Iron Rust —

1. Apply lemon juice and salt and hold over the steam from the spout of a boiling kettle. Wash out in water.
2. Apply lemon juice and salt and place in strong sunlight.

Mildew —(A plant growth in fiber).

1. If fresh, wet in strong soapsuds, cover with a paste of soap and powdered chalk, or chalk and salt, and put in strong sunlight for hours.
2. Apply strong vinegar, lemon juice and salt; or soak in buttermilk and place in the sunlight.
3. Javelle water or bleaching agents may be used but they weaken the fiber of the cloth.

Ink — While the spot is fresh, soak up all possible with blotting paper and by rubbing salt over spot.

1. If on white goods wash in salt and lemon juice; kerosene, turpentine or vinegar and salt.
2. Colored materials—place stain in sweet or sour milk for several days or apply equal parts of alum and cream of tartar moistened in water.
3. Oxalic acid neutralized with ammonia is good.
4. Alcohol and glycerine in equal proportions.
5. For ink on silk material allow wax to fall on the spot from a lighted candle; scrape off the wax when cool and ink will come also; remove the spot caused by the wax by passing a hot iron over a piece of blotting paper placed on spot.

6. Ammonia will remove ink from the fingers.

7. Oxalic acid will remove ink stains from paper, also ink eradicator is good.

Paint—(When fresh). Non-washable materials may be soaked in peroxide, benzine or gasoline.

For old paint, soak in equal parts of ammonia and turpentine.

For cotton cloth use hot vinegar, gasoline or kerosene.

Blood—

1. Soak in lukewarm water to which a little kerosene has been added.

2. On thick goods apply a paste of raw starch. Repeat process until stain has disappeared.

Wagon Grease—Soften with lard or oil and wash in soap and water.

Coffee—Pour boiling water through the stained part of cloth from a height so that it will strike the stain with force.

Fruit Juices—Try the boiling water treatment as for coffee stains. If ineffective try javelle water and boiling water.

Ice Cream—On silk—sponge with gasoline or chloroform, placing a pad of absorbent cotton under the spots.

Scorch—

1. If very bad, sprinkle on borax and water and place in sunlight through window.

2. Sunlight.

3. Peroxide.

Javelle water is one of the best agents for bleaching and removing stains. It should be used for removing stains after all else has failed.

Javelle water should be made as follows:

1 pound washing soda. $\frac{1}{2}$ pound chloride of lime. 1 quart boiling water. 2 quarts cold water.

Put soda in granite pan; add boiling water and stir until dissolved; let cool. Dissolve chloride of lime in cold water; let settle and pour the clean liquid into the soda; let settle. Pour off clear liquid, bottle, and put away in dark place. Use, mixed with equal parts or more of water, and do not let the garments stay in over half an hour. Rinse thoroughly in several waters, and lastly in diluted ammonia water.

To bleach materials quickly dampen and rub with soap, then hang in the sun to dry. Repeat this process until as white as desired.

Boil towels that have become yellow in soap and water with lemon peelings to whiten.

To whiten linen—Linen that has become yellow may be made white by boiling in one pound of white soap to one gallon of milk; or soak in buttermilk.

To keep material white—(Linen, etc.) If put away in a cloth that

has been thoroughly blued, table linen, dresses, etc., will not become yellow.

LAUNDRY HELPS

A laundry bag for the family that will be found very convenient is made in this fashion. Take any strong material and fold lengthwise to the size desired. Close it at the bottom with buttons and buttonholes. At the top where the double fold occurs, place six or more brass rings even distances apart. Put nails in the wall where it is to be hung, one for each ring, and hang the bag on this. Have the opening lengthwise of the front of the bag. To remove the clothes for washing simply unbutton the bottom of the bag and the clothes will fall out.

A clothes sprinkler may be made from a milk bottle. In it place a large cork, insert a garden sprinkling spray in the cork. This will dampen the clothes evenly.

Hard water, or water known as "permanent hard water," can be softened by adding ammonia, borax, soda and lye. "Temporary hard water" can be softened by boiling. The boiling causes the lime and mineral matter to settle to the bottom.

Prussian bluing is a liquid bluing. It should not be used as it is a salt of iron and yellows or spots the clothes, leaving iron rust spots on the clothes. Test for Prussian bluing by mixing the liquid with baking powder, if the mixture turns red it is Prussian blue.

When hanging out clothes, hang handkerchiefs, washcloths and small pieces by the corners and pin on with same pin that a larger piece is fastened on with; this will save time, space and prevent them from being torn or lost.

Dry clothes by hanging in a store room or some clean room not in general use in the winter time, and save yourself from exposure to the cold. A cord may easily be fastened in a room in the house.

Before hanging out clothes in the winter time, rub the hands well with flour or cornstarch and the hands will not get cold as soon as without. White yarn glove fingers may be worn while hanging clothes.

To keep clothes pins from sticking or freezing onto the clothes line, boil the pins while new in a solution of salt and water, and let dry. The salt will encrust the wood and keep the clothes from freezing to the line where pinned.

Old baby buggies may be utilized for wheeling the clothes basket

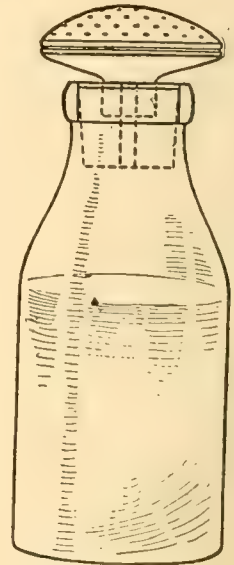

Fig. 4.—Clothes Sprinkler

around. Take off the body of the buggy and nail slats across it on which to place the clothes basket.

Line the clothes basket with white oilcloth and thereby do away with all danger of soiling the clothes, while they are in the basket.

Hang colored clothing on the line with the wrong side out to keep the sun from fading them. In the winter, dry colored clothing in the house as freezing fades them.

Fold clothes when taking off the line and it will save handling them again; also the basket will hold more if clothes are folded.

It is best to have **two sets of clothes pins**, one set for white clothes and one for colored clothes, as the pins used to pin colored materials often become stained and leave a spot on white clothes.

Starch — When making starch, thicken by adding a little flour. A tablespoon of borax to two quarts of starch will give a glossy finish to the clothes and prevent the iron from sticking.

Ordinary starch sometimes starches baby's clothes too stiff. A very fine starch may be made by pouring the water off of boiled rice. It is excellent for baby dresses or very fine laces.

Ironing — In the hot months do as little ironing as possible. The common hand towels, dish towels, sheets, underwear, stockings, washcloths, and bath towels may be straightened and folded without ironing.

Change bed sheets in the summer time on wash day and it will be possible to wash and dry and put them back on the bed again without ironing later in the day.

Place a tin pan over irons on the stove when heating and they will heat much sooner as it keeps all draughts and cold air from them.

Ironing will be much easier if the clothes are allowed to stand over night dampened and rolled. Care must be taken in the summer time that dampened clothes are not allowed to stand long as they mildew quickly in hot weather.

When ironing lace collars, embroideries, etc., place them on a large folded bed sheet and iron. This brings out the pattern and makes the work show up well.

Iron around and between small buttons on fine material by placing them on a folded sheet and ironing on the wrong side.

Iron silk under a cloth, it does not give the silk the stiffness that it would have otherwise and thus prevents silk from tearing so easily. It also gives a softer finish.

If white clothes are soaked over night they will wash much more easily. Soak in soapy water to which has been added turpentine, kerosene, borax or ammonia.

To keep dirt from spreading to other clothes, roll clothes when soaked.

To whiten clothes add a teaspoonful of turpentine, kerosene, or benzine to the washing water.

Clothes should never be put into boiling water as it will set any stains that have not been washed out. Put cold water into the boiler, when lukewarm, soap and add the clothes, bring to a boil gradually and boil for 15 minutes.

When naphtha soap is used boiling is omitted as boiling destroys the effect of the soap. But to keep the clothes white they should be boiled at least once a month. Boiling destroys germs, purifies and whitens clothing.

Soak handkerchiefs in a solution of boracic acid in a separate basin when there are colds in the family, then wash separately and boil for 20 minutes. For sanitary reasons it is always wise to soap and rinse the handkerchiefs before washing with the other clothes.

Put a very frail or thin garment in a pillow case when washing and you need have no fear of it being torn.

When washing light silk waists put a piece of crepe paper the same color as the waist in the rinsing water and the waist will be clear and bright when washed.

Never put woolens or silks into hot water as the hot water weakens the material. Wash woolen sweaters in lukewarm water. Wash by rubbing the soap into the sweater on the board with the hands. Never rub a sweater on the board. Hang the sweater to dry on a long rod or pole run through the sleeves. This will help to keep the sweater in shape.

To wash bed comforters—Make a nice warm soapsuds. Put the comforter in. Take scrubbing brush and scrub the soiled ends, using a washboard to scrub on. Let water off and drain, then fill tub with clean water and rinse. Drain again. Don't try to wring. Put on the line; when almost dry beat with a carpet beater. It will be as light and fluffy as new.

To wash blankets—Use a little soap in the last rinsing water. After they have been hung on the line and are thoroughly dry, beat with a carpet-beater. They will become soft and light, and the wool like new.

For washing flannels—Save the small pieces of laundry, toilet and bath soap until you have a teacup full. Put them into a quart of hot water with a tablespoonful of kerosene. Let simmer until dissolved. Make warm suds with this soap jelly. Set your flannels in the usual way. They will come out clean and soft.

Wash colored clothes in lukewarm water, hang in a shady place, the wrong side to the light. Do not iron with a very hot iron.

To set the following colors, soak over night in the solution given and dry before laundering:—

Pink, 1 cup vinegar to 1 gallon water.

Blue, 2 cups salt to 1 gallon water.

Red, 1 teaspoon alum to 1 gallon water.

Lavender, 1 teaspoon sugar of lead to 1 gallon of water.

Green, 1 gallon of water and 1 ounce of alum.

Black, gray and buff, 1 teaspoon pepper to 1 gallon water.

To wash white silk gloves — Wash in tepid water with white soap and dry at night, as light turns silk yellow.

To wash fine laces — Baste them to a piece of flannel. Make a strong soapsuds to which add a teaspoon of borax to two quarts suds, lay lace in this lukewarm solution, and let soak for ten hours. Squeeze and work suds over lace with the hands. Then put into hot suds and wash carefully. Rinse in several waters until clean. Starch in weak starch or rice starch, and squeeze dry. Tack flannel on a board. When dry remove basting threads.

Wash black lace and ribbon in one cup strong coffee to one teaspoonful of ammonia.

To give lace a yellow color, dip in tea or coffee.

To stretch curtains when a curtain stretcher is not on hand, place a newspaper or a clean sheet on a carpet; straighten and pin firmly to the carpet every inch or so.

To remove wrinkles from clothes which cannot be pressed easily, hang the garment over the bath tub and turn on the hot water. Close the door, leave two or three hours, then hang out in the fresh air. The kitchen will do just as well if it is damp with steam.

To remove shining spots on clothes:—

1. Dark serge may be washed in bluing water.
2. Moisten the spot with ammonia and then alcohol.
3. Pumice stone rubbed in and brushed out.

To clean chamois, wash thoroughly in tepid water and ammonia. Pull into shape as it dries. Rub between the hands occasionally to keep soft. Do not wring.

To clean carpets, sweep thoroughly, then wipe with a clean mop or cloth dipped in ammonia water.

To remove spots on carpets — Spread dry buckwheat on the carpet and allow to stand for a day.

Soot may be removed from carpets by covering it with salt or corn meal. Let stand for a few hours and then sweep off.

Kerosene on carpets may be removed by covering the spots with flour until the kerosene has been absorbed by the flour.

To clean velvets — Light velvet which is much soiled may be cleaned in a pan of gasoline by brushing the soiled parts with a brush. When cleaned hang up in air until all vapor has gone. (Do not wring the material. It should be hung up dripping.)

To take wrinkles out of velvet — Take three thicknesses of damp cotton cloth and place on the wrong side of the velvet. Then draw back and forth over a hot iron. Repeat this until all wrinkles are removed. Dry by passing velvet back and forth over the iron, being sure to keep under side next to iron and always to draw the velvet with the weave of the goods.

How to clean feathers — Take feather to be cleaned and place in one-half pint of gasoline to four tablespoonfuls of flour and let stand for

ten minutes. Then wash in the solution until clean, after which rinse in clear gasoline. Put outside and leave until all fumes are gone. Hold over stove a few minutes to add life to the feather. Curl over the edge of a silver knife.

To clean straw hats — Brush the hat well, wash with soap and water and then with hydrogen peroxide and hang out to dry.

To clean woolen serges, etc. — Put directly into gasoline. (Wash outdoors.) Run clothes up and down in gasoline. Let stand for a short time in the gasoline then rinse in clean gasoline and hang outside to dry. Press. Old spotted suits, coats, etc., can be cleaned this way.

To clean felt hats — White or light colored felt hats can be cleaned by rubbing with sandpaper.

BOOK XI

THE BUSINESS SIDE OF FARMING

THE BUSINESS SIDE OF FARMING

CHAPTER I

FARM RECORDS AND ACCOUNTS

- I. INTRODUCTION—WHAT RECORDS TO KEEP. II. FARM INVENTORIES. III. PLACING VALUES ON PROPERTY—REAL ESTATE—LIVE STOCK—MACHINERY AND TOOLS—FEEDS AND SUPPLIES—BILLS OTHERS OWE ME—CASH ON HAND IN BANK—BILLS PAYABLE. IV. CASH ACCOUNTS. V. PRODUCTION RECORDS—MILK RECORD—EGG RECORD—BREEDING RECORD. VI. THE FARM MAP. VII. SUPPLEMENTARY RECORDS—LABOR RECORDS—FEEDING RECORDS—HOUSEHOLD RECORDS—SEEDING RECORD. VIII. SUMMARIZING THE YEAR'S RECORD—FINANCIAL REPORT. IX. WHAT CONSTITUTES FARM PROFIT—HOW TO DETERMINE. X. SOME RESULTS OF COST INVESTIGATIONS—ANNUAL COST OF MAINTAINING A WORKHORSE—COST OF PRODUCING FARM CROPS—COST OF A DAIRY COW. XI. SUMMARY.

INTRODUCTION

The farmer who does not use his brains in this day of competition for land is being crowded to the poorer and cheaper lands. Farming is a business the same as the manufacturing of shoes is a business. It would be a poor manufacturer indeed who did not know how much an article cost him. By knowing the cost he knows what his profit will be by selling at market prices. The farmer is in the same position as the manufacturer—he has to subtract the cost of production from the selling price of the article to ascertain his profit.

The problem of the farmer is to meet conditions on his own farm in a way which will give him the greatest net returns for his labor and the use of his capital. He should receive interest on his capital as well as wages for his labor, but owing to the lack of proper records few farmers know what wages they actually receive. There is reason to believe that the majority of farmers are really living on the interest of their investments rather than on the profits of their farms.

The successful business of today receives a business administration. Scientific management of factories, railroad shops and business houses is the rule on every hand. It is not surprising that farming, the greatest industry of the world, in order to succeed should require practical business-method practices. Farming is now considered a business that demands and deserves a systematic order of administration. To provide this properly and successfully it becomes necessary to know certain facts about the individual business of farming. To ascertain these facts one must keep certain records of the business.

What Records to Keep—It is difficult to say offhand what records should be kept by each farmer. Types of farming are as numerous as kinds of stores, but in general those records that will tell the operator the gains and losses of the different enterprises of his business should be kept. This does not mean “bookkeeping” in the old sense, neither does it mean cost accounting in the detailed investigational sense. Any farmer can keep certain facts of his operations as they occur if he can read and write, although he knows absolutely nothing of debit or credit and such terms. The first requisite is to know what is essential to record the facts that can be *used*. It is worse than useless to keep accounts “just to be keeping them.” The kind of form on which the figures or notes are kept is not essential, although the simplicity of the forms may be important. If one starts out with the idea of knowing where the gains and losses of a business lie and of using the information, there can be no question of the value of farm records.

The following outline may be of value in separating the essential or primary records from the secondary or supplementary.



If one knows what each of the above records tells about the business, and how the results can be used to advantage, their value will be apparent to him who really is seeking to know more about his farm business. It is suggested that the actual keeping of records, by one unfamiliar with them, be approached by degrees, that is, starting with one and working into others as each brings experience and valuable practical knowledge.

FARM INVENTORIES

The most important single farm record is that of the inventory at the start of the farm year and at the end of the farm year. When properly taken the results tell more than any other one record.

An inventory is simply a tabulated list of what is on the farm at a given time. The various items are usually grouped for convenience under several heads or divisions merely as a means of systematizing the record. Such a list of property shows the total and proportionate investment, the bills owed to and by the proprietor and the net worth of the business. The net worth is the total value of all the property owned by the proprietor, plus the amount owed to the business, less the amount owed by the proprietor. The latter are known as “Bills Payable” or “What I Owe Others.” The second inventory, taken at the end of the year, should be placed by the first one for comparison. If the total net worth of the second invoice is greater than the first one there is a gain or increase in inventory; if less than the first, there

is a loss or decrease in inventory. Hence the two inventories show the loss or gain on the business. The big valuable point they do not show is just where the losses or gains occurred.

The following is an example of a farm inventory at the start and end of a farm year. This shows the grouping of the items under Real Estate, Live Stock, Machinery and Tools, Feed and Supplies, Bills Receivable or due the proprietor, Cash on Hand or in Bank and Bills Payable. The Summary at the end of the inventory lists these in total and shows the net worth and increase in inventory.

INVENTORY

Sample farm inventory: Farm of ———

Property.	April 1, 1914			April 1, 1915		
	No.	Rate.	Valuation.	No.	Rate.	Valuation.
REAL ESTATE.						
Farm of 180 acres (155 tillable), including buildings (dwelling \$1,600, barns \$1,800, other buildings \$600), fences, and other improvements.....			\$13,500.00			\$13,500.00
LIVE-STOCK.						
Dairy cattle:						
Cows, dry and in milk.....	24	\$50.00	\$1,200.00	26	\$50.00	\$1,300.00
Bull.....	1		50.00	1		45.00
Calves.....	6	14.00	84.00	8	15.00	120.00
Two-year olds.....	4	28.00	112.00	6	20.00	120.00
Total value of dairy cattle.....			1,446.00			1,585.00
Hogs:						
Brood sows.....	2	22.00	44.00	2	21.00	42.00
Pigs.....	8	4.00	32.00	6	3.00	18.00
Total value of hogs.....			76.00			60.00
Horses:						
Horse, Jim, 7 years old.....	1		200.00	1		180.00
Team, Nell and Bess, 5 and 6 years old.....	1		425.00	1		425.00
Team, Jack and Prince, 6 and 7 years old.....	1		400.00	1		400.00
Colt, 1 year old.....	1		75.00	1		145.00
Total value of horses.....			1,100.00			1,150.00
Poultry:						
Hens.....	160	\$0.60	\$96.00	125	\$0.60	\$75.00
Roosters.....	5	1.00	5.00	4	1.00	4.00
Turkeys.....	2	3.00	6.00	2	3.00	9.00
Total value of poultry.....			\$107.00			\$88.00
Total value of live-stock.....			2,729.00			2,883.00
MACHINERY AND TOOLS.						
Grain binder.....	1		90.00	1		82.00
Sulky plows.....	2	45.00	90.00	2	41.00	82.00
Disk harrow.....	2	28.00	56.00	2	25.00	50.00
Mower.....	1		35.00	1		30.00
Hay rake.....	1		20.00	1		19.00
(List all items of farm machines, wagons, harness, and small tools.)						
Total investment in machinery and tools (not all listed here).....			475.00			461.00

Samule farm inventory: Farm of—Cont'd.

Property	April 1, 1914			April 1, 1915		
	No.	Rate.	Valuation.	No.	Rate.	Valuation.
FEED AND SUPPLIES.						
Farm products:						
Corn..... bushels..	80	.60	48.00	125	.60	75.00
Oats..... do.....	200	.42	84.00	90	.50	45.00
Potatoes..... do.....	40	.75	30.00	80	.60	48.00
Hay, timothy..... tons..	10	16.00	160.00	20	15.00	300.00
Hay, mixed..... do.....	5	12.00	60.00	4	12.00	48.00
Silage..... do.....	40	4.00	160.00	40	4.00	160.00
Brant..... do.....	0 $\frac{1}{2}$		15.00			
Mixed feed..... do.....	1		31.00	2 $\frac{1}{2}$	30.00	75.00
Seed oats..... bushels..	30	.50	24.00	35	.80	28.00
Seed potatoes..... do.....	45	.80	36.00	50	1.00	50.00
Seed corn..... do.....	3	2.00	6.00	3	2.00	6.00
Cement..... sacks.....	4	.50	2.00			
Twine..... pounds.....	20	.10	2.00	10	.10	1.00
Total value of feed and supplies.....			658.00			836.00
BILLS RECEIVABLE.						
J. A. Brown, hay..... tons..	2	13.00	26.00			
R. S. Jones, potatoes..... bushels..	40	.50	20.00			
Total.....			46.00			
CASH.						
On hand.....			90.00			210.00
In bank.....			580.00			1,938.00
Total.....			670.00			2,148.00
BILLS PAYABLE.						
Farm mortgage.....			2,000.00			1,500.00
SUMMARY.						
Real estate.....			13,500.00			13,500.00
Investment.....			2,729.00			2,883.00
Machinery and tools.....			475.00			461.00
Feed and supplies.....			658.00			836.00
Bills receivable.....			46.00			
Cash on hand and in bank.....			670.00			2,148.00
Total investment.....			18,078.00			19,823.00
Bills payable.....			2,000.00			1,500.00
Net worth.....			16,078.00			18,323.00
Increase in inventory, \$2,257						

Taking the Actual Inventory—In taking down the values of property on the farm it is advisable to place all the stock on one page in a notebook, the machinery on another page and so on. This will permit of a checking over before copying onto a form similar to the one shown above. The best time to take an inventory is when the supplies are the lowest. This is usually March or April 1 in the Northwest.

PLACING VALUES ON PROPERTY

Real Estate—The number of acres should be given and a fair value placed on the land without the building values included. Endeavor to place a value that the farm would bring if sold at that time—not what was originally paid for the land. The buildings should be valued separately, thereby realizing often that there is an overcapitalization in farm buildings.

At the close of the farm year the value of the land should be the same as the first inventory unless extensive tiling, ditching, land clearing or similar permanent improvements have been performed during the year. If the value is increased by speculative rise in the land values at the end of the year a true gain of the operated farm business will not be shown. If, after determining the farm gain or loss, it is desired to add the speculative gain this may be done although it should be remembered this kind of gain is not actual cash or its equivalent. If the buildings have not been repaired it should be remembered there is usually a depreciation of from 3 to 5 per cent of the original value. The repairs and new buildings added during the year will govern this.

Live Stock—Market prices operating at the time of inventory should govern the values on live stock unless special performance or pure blood deserves higher prices. Exchange values should always be borne in mind in the endeavor to obtain as near a true value as possible.

Machinery and Tools—An itemized list of machinery should be made and, if possible, it is desirable to know the approximate initial cost of the machinery and the year purchased, in order to place a fair value on the machines. After the first fair value a depreciation charge of from 6 to 10 per cent per year, either on each machine or on the total value may be charged and a fairly good result obtained. The depreciation or lasting life of a machine depends on many factors, chief among which are proper lubrication when in use, and shelter when not in use. An itemized list of tools is of value in checking up and keeping in place the many small tools that accumulate on the farm. Many valuable hours of time in busy seasons are wasted because the tools are not to be found when needed.

Feeds and Supplies—Under this heading should be included the feed and seed for sale and for feed; such supplies as twine, lumber, cement, salt, cut wood, oils, etc. For farm-raised supplies, the market price less cost of hauling should be used to determine the value.

The marketing cost will average two to three cents per bushel for grain and about two to two and a half dollars a ton for roughage in the Northwest. It is usually difficult to estimate accurately the amount of hay, grain and feed on hand, unless care is taken to measure the mows and bins, or a knowledge of the yields, sales and feeding practices is had by the farmer. The common method of figuring ear corn in the crib is to obtain the number of cubic feed in the crib and divide by $2\frac{1}{2}$, to obtain bushels; with small grain, divide by $1\frac{1}{4}$; and with hay, to obtain tons, divide the cubical contents by, from $3\frac{1}{3}$ to $5\frac{1}{2}$, depending on the compactness of the hay.

Bills Others Owe Me—These are commonly known as "Bills Receivable" and should be entered in the inventory as a part of the value of the property investment of the farm. As far as the inventory is concerned these items are similar to cash—they are assets of the business. The entering of them in the inventory also serves to call attention to the amount of money due the proprietor from others. It is only business practice to know

the amount of the debt, the debtor, and the kind of property the debt represents.

Cash on Hand and in Bank — This amount is placed in the inventory as an asset and added in with the rest of the property to obtain the entire investment. In order to know the true gain or loss this item at the start and end of the year becomes very important.

Bills Payable or "What I Owe" — From the sum of all the foregoing assets the amount of money owed by the proprietor must be deducted. The remainder represents the net worth of the business. This simply means what the business is worth clear of all debts. These bills are known as liabilities or costs against the business. In this class are farm mortgages, store bills, feed bills, interest due others, etc. To obtain the net worth, it must be remembered that all incumbrances or debts against the business must be taken from the sum of the assets or property-investment values.

For convenience and ease of understanding it is essential to make a summary of the main heads of the inventory as shown in the Sample Farm Inventory.

CASH ACCOUNTS

It is seen, from the above, that an inventory properly taken at the start and end of a year will give the total loss or gain, but that it will not pin the losses and gains on to the particular enterprise—crops or groups of live stock responsible for the result. With the proper keeping of the cash account this may be done. There are other reasons for knowing the source of receipts and for what the funds are expended. Such a record will enable one to know at any time the cash balance or "standing" of his accounts; a record of disbursements on particular enterprises affords an opportunity for intelligent judgment regarding the possible profit to be derived from them; while the keeping of receipts from cows, crops, hogs, etc., often tells the operator facts that are of great value in the profitable management of the business.

In order to keep a complete cash record and to be able to know the cash "balance," it seems necessary to keep the household and personal cash accounts. Records indicate that very often these two accounts constitute almost half of the number of items entered in the cash account. This makes more detailed work than all the other accounts and it is suggested that these be entered in as large amounts and as few entries as is possible for accurate records. Often the grocery and personal bills can conveniently be paid once a month and the monthly amount entered in one entry.

There are several methods of keeping a cash account and one should consider the value of the yearly results in selecting the cash system. There is no system that is "self-keeping," that is, any system requires some work in entering items, some work in adding, and some labor in studying the results at the end of the year. Four methods will be described and illus-

trated in this text with advantages and criticisms of each. The most common method that at first suggests itself to a large number of persons when starting a cash system is simply to write one item after another on a page and place the amount received or expended in a column opposite the item. One may have one page for receipts and another for expenditures as shown in the following illustration.

ONE METHOD OF KEEPING CASH RECEIPTS AND EXPENDITURES

RECEIPTS.

19—

April	2	20 bushels potatoes, at .60.....	\$12.00	
	2	18 dozen eggs, at .21.....	3.78	
	7	2 tons hay, at 16.00.....	32.00	
	7	1 cow to J. Brown.....	47.50	
	7	30 dozen eggs, at .20.....	6.00	
	7	3 bushels seed potatoes, at 1.00.....	3.00	\$104.28

EXPENDITURES.

19—

April	2	1 ton cottonseed meal for dairy.....	\$35.00	
	2	Strap for work harness.....	.35	
	2	Personal.....	2.25	
	2	Household.....	1.60	
	7	Garden seeds.....	8.00	
	7	Express on seeds.....	.85	
	7	2 milk pails.....	2.00	
	7	Household.....	.86	
	7	Repairing plow.....	1.20	\$52.11

A modification of this system is to have two columns to the right of the page, one for cash received and one for cash paid out, but the system of entry is the same. The value of this system, or rather the one good point, is that little space is required for the cash account. The great fault with it is that one cannot know the receipts or expenses of any one particular enterprise without going over the account and picking out the items. This is very unsatisfactory in practice and is not to be recommended. Another fault of the modified system with two columns is that very often the person keeping the account will place receipts in the expense column and vice versa.

The second system is that of having a separate page for each account as dairy, hogs, poultry, corn, etc., with expenses on the left-hand page of an open book and receipts on the right-hand side with the items between, or the columns may be side by side on one page if great care is taken in entering the receipts or expenses in the proper columns.

The principal criticism of this system is that one must have a separate page or pages for each account and if many accounts or enterprises are being managed on the farm the method may prove irksome. The carrying forward of the final footings to a summary is also an extra task that experience shows is rarely accurately performed by the average farmer keeping accounts. This method is to preferred to the first one, however. The following

illustrates this method on different pages—one for cash received and one for cash paid out.

CASH ITEMS ENTERED DIRECT TO THEIR RESPECTIVE ACCOUNTS

DAIRY.

19—			Received.
April	9	2 cows to C. Brown.....	\$88.00
	9	1 yearling to Smith.....	19.00
	15	Milk and cream.....	114.25
			\$221.25

DAIRY.

19—			Paid.
April	2	1 ton cottonseed meal.....	\$35.00
	2	2 milk pails.....	2.00
	10	1 cow from A. Johnson.....	57.50
	10	One-half ton bran.....	15.50
			\$110.00

The third method is known as the special column account book with one entry serving as the first and only one, that is, the expense or receipt is "posted" or placed at once under the proper column or account. This requires more space and a larger book but time and labor is saved by this method. The receipts and expense accounts are kept separate in different parts of the book but under similar headings so that one can be subtracted from the other at any time. The first column on both the cash received and cash paid out pages is marked "Total Cash"—each amount is entered here first and then distributed to the proper account. By doing this one can find the total receipts or expenses by merely adding one column of figures instead of six or more as in the other methods. This system is illustrated as follows:

FORM ILLUSTRATING SPECIAL COLUMN CASH BOOK—ITEMS ENTERED DIRECT TO SEPARATE ACCOUNTS

RECEIPTS.

19—		Item.	Total Cash.	Dairy.	Poultry.	Crops.	General.
April	2	2 yearlings to Jones.....		\$35.00			
	3	2 tons of hay to Brown.....				\$32.00	
	4	14 dozen eggs, at 25 cents.....			\$3.50		

EXPENDITURES.

19—		Item.	Total Cash.	Dairy.	Poultry.	Crops.	General.
April	2	1 ton wheat bran.....		\$28.00			
	2	10 bushels seed oats, at \$1.....				\$10.00	
	7	2 bags chicken wheat.....			\$2.50		

One could have more columns and divide the crop among corn, oats, wheat, etc. In the actual entering of items in any of these systems, it is

best to state the date of transaction, the amount in pounds, tons, dozens or number of units bought or sold, and the price per unit. This is not always convenient or possible, but such information often becomes very valuable.

<i>Balance brought forward</i>			<i>Date</i>	<i>No.</i>
<i>Amount deposited</i>			<i>To</i>	
<i>From</i>			<i>For</i>	
<i>For</i>			<i>Figure Here</i>	
<i>Date</i>				
<i>Total</i>				
<i>Amount this Check</i>				
<i>Balance carried forward</i>				

TOWN, STATE, _____ 191 _____ No. _____

FIRST NATIONAL BANK

UNITED STATES DEPOSITARY

Pay to the order of

_____ \$ _____

Dollars

For _____

The fourth method is one that may be impossible for extensive use inasmuch as it contemplates the keeping of the account by the local bank and a system of reports to the farmer by the bank. With this method the farmer does strictly a check business, that is, pays all bills by check, and writes on the deposit slip and on his bank stub the amount of deposit, from whom and for what the money was received. At the end of the month the bank can very easily report the bills paid and money received and for what each transaction was performed. A yearly summary can easily be made from the monthly statements and the bank does the bookkeeping through the year. This plan is being tried out with success by a number of farmers and the banks seem willing to assist in a businesslike method of carrying on the farmer's cash account. The illustration shows the bank check and stub on which complete data can be written that will enable the proper keeping of the records.

PRODUCTION RECORDS

The production records of live stock and crops are of great value in sup-

plementing the cash account and inventories to afford a complete knowledge of profitable and unprofitable enterprises. Obviously it is not good business practice to expend labor and capital on cows, sows, horses and crops that are not productive enough in themselves to pay a profit. A farm as a whole may yield a profit, but various enterprises thereon may be "boarders" or living on the profit of other enterprises. A practical value of farm records lies in ascertaining where the leaks exist and employing steps that will stop the leaks. If ignorance of true conditions is the reason for present non-productive farm enterprises, there is great hope for a more profitable farm business; for the facts can be known by keeping records and the remedy is always applicable once the facts are known.

When production records are mentioned the usual thought is of milk or dairy records. While these are of great importance on a dairy farm there are other equally important records for farms on which no cows are kept. The feeding farm, the hog farm, the crop end of the business, all require a record of production, so that all the essential facts of their most profitable and least profitable practices may be known.

In Book XI, Chapter VIII, "The Science of Dairying," advice is given on keeping dairy records with forms and equipment required, hence no further mention will be made of them here. The feeder of beef cattle should know very closely how many pounds of gain is being received for the feed consumed. He should be familiar with the rate of gain; the margin or "spread" between the buying or selling prices; and the relative feeding values of the feed with which he is dealing. All of these points are an essential part of his business and the best feeders of beef cattle are those who know most of these things. A pair of wagon scales with a stock rack, a scale or notebook and a pencil should be considered as first essential equipment for hog or cattle feeding. Under the heading of "Feeding Records" will be discussed methods of easily computing the average amount of feed consumed.

The producer of pork surely should have accurate figures on the number of pounds of pork obtained per bushel of corn, or hundred pounds of feed consumed.

High prices of foodstuffs demand that the operator know the relative values if sold as grain or in form of meat or milk. This is not idle figuring but real practical profitable knowledge. Likewise the number of pigs in each litter from each sow should be noted and some idea gained as to the particular good or bad points of the mother sows. One farmer in Minnesota has a five-year average of over eight pigs twice a year or over sixteen pigs per season. The records are there to prove it and they constitute valuable data for that farmer.

Up-to-date poultry management insists on egg records and feed records of the poultry kept. It is becoming more widely known that a side cash income of no mean proportion can be realized from the too often neglected farm poultry. With the recent parcel post possibilities in marketing many

THE FARM MAP

The keeping of the cash account, the taking of the inventories, and the keeping of the important production records will tell the farm operator where and why money is being made or lost. They will furnish information, that, if properly used will stop the leaks and increase the net income. There can be no question about this for all the farm enterprises will be productive and that means farm profits. There is one other essential record, however, that is of great value to the farmer in his dealings with his farm land and that is the farm map or plat. This might be called a "mechanical" record and one less active than the others, that is, not requiring constant attention through the year. This is an argument in favor of it and no farmer can be so busy as not to have time to pace off or measure his fields and arrange on a sheet of paper as a map. There is no need of expert engineering ability in making a rough sketch of the farm fields.

It is, of course, best to attempt to draw the fields somewhat near to scale in order to obtain a correct view of the farm as a whole in its true relation to the various fields. If each farmer could get above his farm and see it as it actually lies, there would be many sudden and violent changes. Changes in fencing, area of fields, and crops readily suggest themselves in looking over a farm map. This should be a first step in planning a crop rotation, a minor stock rotation, and in the laying out and planning of the farmstead. The latter should be drawn out on a large scale and the buildings, groves, fences and natural features placed on the farmstead map. Were this always done before a new building was placed on the farm, there would be many more conveniently arranged farmsteads that would mean greater comfort and the actual saving of dollars in carrying on the farm operations.

The following chapter of this book deals with the planning of the farm and farmstead for profit and convenience. It should receive careful study.

The above four essential records may seem complicated at first thought, and doubt of their real practical value may arise in the minds of many farmers who have never kept any records. For those it is wise to start slowly; take an inventory at the start of a year and one at the end. The next year start a cash account and try to know what cows are paying or what the crops are doing and one will be surprised at the feeling of "business importance" that goes with real business achievement on the farm.

SUPPLEMENTARY RECORDS

A complete study of the farm business entails the keeping of other than the four essential records described in the preceding pages. If one is thoroughly to understand the factors that contribute to profits and efficiency in farming, attention must be given to labor, feeding and other records. Often a complete detailed study and analysis are impossible without knowing the labor requirements and labor efficiency. Where live stock forms an important part of the farm business the

feed requirements and cost are important factors to be known. The only way to accomplish these results is to keep records of the actual operations embracing them. Live-stock and crop-cost tables cannot be accurately formulated without the labor and feed items.

Labor Records—Labor cost plays a most important part in the cost of producing farm products. Published results from the Minnesota Experiment Station show that labor constitutes 50 per cent of the cost of growing corn and 30 per cent of the cost of growing small grains. The annual labor cost of maintaining a cow is over 50 per cent of the feed cost of the animal. Hence it is an important item and yet it is one which it is very difficult to keep properly and use the results of records. For that reason it is doubtful if many farmers will keep, in the many phases necessary, any sort of a satisfactory labor record of the farm business. A certain number can attack the problem and achieve very good results. The others should apply published results of detailed cost-accounting studies to their individual-enterprise operations to fairly approximate the labor cost. These figures may be obtained in bulletin form and can safely be used in approximating the cost of man and horse labor. For those who desire to learn their own actual labor cost the following is written.

MONTH OF <i>June</i> 5		MONTHLY WORK REPORT																									
		Corn			Wheat			Oats			Rye			Hay			Horses		Cattle		Hogs		Misc.		Total		
Day	Month	Man	Horse	Man	Horse	Man	Horse	Man	Horse	Man	Horse	Man	Horse	Man	Horse	Man	Horse	Man	Horse	Man	Horse	Man	Horse	Man	Horse		
1		5	10					10	40					1 1/2		5 1/2		1								93	50
2		10	20					10	20					2		8		2	2 1/2		2	2				34 1/2	44
3		9	18					9	19					1 1/2		6 1/2		1			4 1/2	1				32	38
Sunday	4													3 1/2		8 1/2		1 1/2						4		10 1/2	4
5																											
6																											
7																											
8																											
9																											
10																											
11																											
12																											
13																											
14																											
15																											
16																											
17																											
18																											
19																											
20																											
21																											
22																											
23																											
24																											
25																											
26																											
27																											
28																											
29																											
30																											
Total	31																										

FIG. 1—Illustration of a form of monthly labor-report blank.

To be of greatest value it is necessary to keep a labor record in terms of man and horse hours spent on the various enterprises. If

this be done by operation, as plowing, harrowing and planting the corn, it will require more detailed study and more space and final figuring. If each day's labor of man and horse is apportioned to the proper enterprises as corn, hay, cattle, etc., without the description of the operation performed, the record becomes more simple. With all these supplementary records it should be borne in mind that the value lies not in merely putting down certain figures but in studying and using them after they have been kept, and added into a final result at the end of the month or year. For keeping a record of labor by enterprises and not by operation the form shown in Figure 1 has been found very satisfactory.

In using this form only the total hours are recorded and no record is made of the labor of different workers. If it is desired to keep the daily time by operation and it is not essential to keep each man's labor separately, a symbol system of denoting the operation will be found adaptable to the above form. For instance two or three spaces might be left for each day and symbols or letters used to show the kind of work done, as, P for plowing, H for harrowing, D for disking, etc. These would each have to be gone over and added separately to obtain the separate operation totals for each crop or field as desired.

Where cost-accounting investigations are carried on in the endeavor to study in detail the farming business of a record, each man's labor is kept separately, in which case Fig. 2 shows a form illustrating the manner in which each man keeps his own labor. These are sent to a central office and tabulated. Obviously such forms are not practical for the operator who must tabulate and classify the labor in order to properly understand the results. For that reason practical farm records should not be confused with detail cost-accounting investigational work. The latter corresponds to the timing of factory operators in the new "Scientific Management" of certain industries.

Feeding Records—The keeper of live stock should be a student of live stock practice. The fact that a man is a live-stock farmer means that he has considerable capital invested in live stock. A part of the working capital, namely horses, is in live form. Because of the capital invested, because of the risk existing, and because the wisest of men cannot know enough about live stock, it is sound advice to say that a dealer in animals, whether dairy, beef or work stock, should take pains to know all possible about their feeding and management. For the careful man it is not enough to know that a cow eats hay and oats and corn or that a horse displays a liking for oats and hay. How much should each kind of stock have of each different kind of feed for the return to the farmer in the form of milk, beef or work? That is the important point although another of importance is, which feed is cheapest for the necessary efficiency? Thus the economy of feeding,

Regular Worker's Daily Time Sheet.

Frank Smith

Day of Week: Monday Date July 10

	KIND OF WORK. Include implements used, number of loads, etc.	FIELD.	MAN HOURS	HORSE.	
				NO.	HOURS.
4.30--					
5.00--					
5.30--	milking & care of cows				
6.00--	Breakfast				
6.30--					
7.00--	Take milk to depot		1/2	1	1 1/2
7.30--					
8.00--					
8.30--					
9.00--					
9.30--	Plowing corn	J	4	1	4
10.00--					
10.30--					
11.00--					
11.30--					
12.00--					
12.30--	luncheon				
1.00--					
1.30--					
2.00--					
2.30--	Hauling hay	B			
3.00--	working with Mr. Smith		4 1/2	2	9
3.30--					
4.00--	hauled in 4 loads				
4.30--	about 1 ton each				
5.00--			1/2		
5.30--	care of team				
6.00--	Supper				
6.30--	milking		1/2		
7.00--					
7.30--					
8.00--					
WORKMAN	O. Neal	TOTAL HOURS	12		14 1/2
REMARKS	Need rain. Corn suffering Hay short		REPORT O. K. <i>J</i>		

Fig. 2.—Illustration of a Desirable Form of Detailed Farm-Labor Records for Investigational Work.

especially when feeds are high in price with stock and the products relatively low in price, enters into the problem of feeding. It is surely poor business policy to market valuable field crops in the form of live stock or its products without knowing the cost of the marketing method.

Farm records indicate that the farmer makes a higher wage per hour in the field than in the barn working with live stock. How important it is then that the stock be productive and add profits rather

than consume the profit made in producing the crops fed. Only one way exists that will tell whether it pays to feed certain animals, and that is by keeping a feeding record together with a production record.

By using the results shown, the herd may be improved and profits added to those already made in the field. The kind of form used for this record depends somewhat on the kind and number of live stock kept on the farm. Beef, cattle and hog production on a car lot scale may permit of special forms and methods of arriving at the food consumed. For the average farmer, keeping four horses or over; from four to twenty cows with young stock, and marketing a carload or so of hogs yearly the form on the next page is suggested. If he wishes to divide each class of stock into two or three divisions and keep each kind separate on the feeding record this form may not be applicable.

Feeding Form—A brief study of this form shows that all the multiplying done to produce the total amount of feed fed to any one class of stock is plain and simple figuring directly before the operator. The only point in question may be the method of arriving at the average amount fed per head per day. This depends somewhat on the kind of feed—often the number of ears of corn fed per animal daily can be easily known and then, by weighing a hundred ears or so, a fair average weight per ear is obtained. The best method with small grain feeding is to use certain measures, as baskets, pails, scoops, etc., in feeding the various classes of stock or individual animals. Weighing these occasionally to arrive at a fair average weight will give a fairly accurate record. This practice will not only tell the amount fed but it will create interest and a desire to know more of the science of correct feeding.

If the feeding is largely that of car lot of stock the bulk system of keeping the record may give the total amount of feed and the feed cost of production, but the daily ration cannot be determined with this method. The real value of a feeding record lies in knowing from day to day the approximate daily feed cost, and the work or gain received for the feed consumed. One of the first requisites of the bulk method is to have certain bins of grain, or cribs of corn, or mows of hay that will be fed to a certain number of head of stock. Invoicing the amount of feed on hand at the start of the feeding period and again at the end of the period will give the feed consumed. A number of men practice the plan of having the grain bins marked off on the door or side of the bin, with notches or black marks indicating the capacity of the bin in the number of bushels at each mark. For example, one foot from the bottom of the bin, the capacity is 100 bushels of grain, two feet, 200 bushels and so on—this is really calibrating the grain bins to provide easy and rapid invoicing at any time.

This plan will not be as satisfactory for hay and roughage and ear

Month: April, 1915.

MONTHLY FEEDING RECORD

Kind of Feed	HORSES		COLTS		MILK COWS				OTHER CATTLE		HOGS		POULTRY	
	Ear Corn	Oats	Tim. Hay	Hay	Bran	Oats	Silage	Hay	Fodder	Hay	Corn	Milk	Oats	Milk
Av'g. lbs. daily, per head.	7	8	22	15	4	6	25	12	20	10	5	100 lb. to all	30 lb. to all	50 lb. to all
Number days fed	15	30	30	30	30	30	25	30	30	29	30	30	30	30
Total, per head, lbs.	105	240	660	450	120	180	625	360	600	290	150	3000	900	1500
Av'g. number head fed	6	6	7	2	8	8	10	10	12	12	30	3000	900	1500
Monthly total, lbs.	630	1440	4620	900	960	1440	6250	3600	7200	3480	4500	30000	9000	15000
Price, per lb., or bushel.	1c lb.	1c lb.	6 cwt	6 cwt	1 1/2c	1c	3 cwt	6 cwt	5 cwt	6 cwt	1c lb.	20c cwt	1c	20c cwt.
Value feed	\$6.30	\$14.40	\$13.86	\$2.70	\$12.00	\$14.40	\$9.38	\$10.80	\$18.00	\$10.44	\$45.00	\$6.00	\$9.00	\$3.00

MONTHLY COST SUMMARY

PASTURE RECORD

Feeds Fed	Ear Corn	Oats	Hay	Bran	Silage	Fod- der	Milk	Past- ure	Total Cost	Field	Kind	No., day	No. head	No Rate	Cost	Remarks
Total value fed to horses.	\$ 6.30	\$14.40	\$16.56					\$ 37.26		A	Rye	30	20	50c	\$10.00	
Total value fed to cattle.		14.40	21.24	\$12.00	\$9.38	\$18.00		\$5.02		B	Rye	30	30	10c	3.00	
Total value fed to hogs.	45.00						\$6.00	54.00						hd.mo.		
Total value fed to poultry.		9.00					3.00	12.00						hd.mo.		
Grand total value feed	\$51.30	\$37.80	\$37.80	\$12.00	\$9.38	\$18.00	\$9.00	\$188.28							\$13.00	

NOTE:—Twelve of these are added at end of year for each class of stock and each kind of feed.

corn as it is for small grain. Often the acreage of roughage and corn is noted to obtain the amount of feed consumed—the yield either estimated or the cost of production estimated, and this cost charged directly against the live stock. There is a current question as to whether feed should be charged to the stock consuming it at the market price less cost of marketing, or at the price of production cost. The proper method with feed that has another market than live stock, should be that of charging at the market price less the marketing cost. Unless this is done the field operations and the crop profits in the cost of production are entirely subordinated to the live stock. Following this practice is likely to result in lowering the standard of minimum live-stock production, especially in milk, for if large yields are obtained the cost per bushel will be low and hence a low producing unit of live stock may show a profit.

Each productive farm enterprise should show a profit—if not, that enterprise requires attention—it would be impossible to determine this in the case of crops, were the basis that of production costs. Is it always advisable to feed the crop rather than sell it? Is it good management to lose the field profit by feeding low producing live stock? These are practical, important questions that each man must rightly answer in his practice, if profits are to be large and the business worth while.

Household Records—The farm business is peculiar in that the household plays a most important part in the management and operation of the farm. It is almost impossible to keep the home business separate from the farm business. The home usually boards and shelters the farm help, the housewife usually performs the labor of providing food and caring for the laborers living on the farm. Her labor is usually unpaid labor and hence is difficult of financial interpretation. Farm produce is used in the household in the process of furnishing food and fuel and hence becomes a part of the farm business. For these reasons a complete record of the farm business entails the keeping of a household record to determine properly the profits in the business. With the understanding that the returns may be expressed as the labor income, the principal record required, other than the cash account already discussed, is that of the amount and value of the farm produce used in the house. The fuel can easily be computed from the cash account and wood lot inventories but the eatables are derived from various sources, usually in small amounts, so that some record of their consumption is necessary.

There are two general ways in which a household record of "farm produce used" may be kept. One requires a monthly record kept daily—that is, the daily consumption is indicated on a form which when filled gives the record for a month. An illustration of such a form follows:

FARM PRODUCE

Farm of		Month					Year		
Date	Eggs Laid	Poultry Used	Milk Used	Butter Made	Eggs Used				
1									
2									
3									
29	*	*	*	*	*	*	*	*	*
30									
31									
Totals									

NOTE—The weights of any farm animals, such as hogs, veal, etc., slaughtered during the month should be recorded in one of the blank columns above.

The second method is that of estimating at the end of the month the approximate amount of each kind of produce consumed during the month. The form for this method contains a year's record on one page. The columns are added at the end of the year, an average price is applied and the cost determined. While perhaps not as accurate as the former method, it is easier to keep and can be made fairly accurate by estimating each month, the average daily amount consumed and multiplying this by the number of days in the month.

The practical value of the household accounts lies in their use in determining the cost of man labor per hour, for use in obtaining the labor cost of production. The board cost amounts to about one-third of the total labor cost—hence it is a necessary item in cost-accounting work. For the average farmer a charge of \$15 per month for board and washing can safely be used in estimating as a part of the labor cost.

Year 19—

FARM PRODUCE USED IN HOUSEHOLD
(To be estimated and entered once a month)

Month	Cream and Milk	No. Eggs	Poultry, Lbs.	Potatoes, Bu.	Other Produce

To be added at end of year and an average price used to determine cost.

Seeding Record—In order to bring into the financial accounts all the values, both cash and items not cash, consumed during the year, it is necessary to know the amount and value of the home-grown seed

used from the previous year's crops. To be able to charge the seed against the proper field, it is of value to know on what field the seed was sown. These facts can be easily and simply recorded on any book page by simply ruling a few vertical columns and placing these headings at the top of the columns; kind of seed, dates sown, amount of seed, field where sown, number of acres, value of seed. To this may be added the dates of cutting, threshing and marketing in order to make a sort of a crop history of the record. Such notes, while of no economic value directly, often serve as guides or references for future crop practices.

SUMMARIZING THE YEAR'S RECORDS

The Financial Report—The practical farmer immediately thinks of the value of farm records to his business. How can I use these figures kept during the year? That is the question that he asks and unless there is a satisfying answer the records will not be kept.

Results are what count, not details of methods or management. The man who faithfully keeps the essential records of his business will be very little benefited unless he can summarize and properly interpret his results. The first report that is usually desired and which seems most important at the end of the farm year is the financial report. Everyone is interested in learning the financial standing, the profits and the losses of the various enterprises, and the total farm loss or gain. Such a report can be made very easily if the records have been kept up to date during the year. It is exceedingly difficult to make a financial statement if a large number of items have been left out and estimates must be made. Making a statement from memory is usually unsatisfactory.

WHAT CONSTITUTES FARM PROFIT

Very few farmers figure profits correctly. In fact many agricultural experts in figuring results often overlook important costs, thereby showing a large, though false profit. Let us assume that \$20,000 is invested in a farm business and that the current rate of interest on farm loans is 5 per cent. If this \$20,000 were loaned out at this rate it would earn a revenue of \$1,000 per year without any effort or labor on the owner's part. Therefore the first \$1,000 net income on the farm represents the interest on the investment and not profits. Assuming further that the unpaid family labor is worth \$300 and the owner's time and managerial ability is valued at \$500, the next \$800 of net income represents wages and not profit. In this case the net income would have to exceed \$1,800 in order to have any real profit.

How to Determine Farm Profit—To determine the real profit made during the year the following accounts are necessary:

- A. Two inventories, one at the beginning, the other at the end of the year.
- B. A cash account in order to show personal and household expense, interest paid on indebtedness, and cash on hand at end of year.
- C. The value of farm produce used in the household.

Statement showing a method of determining the farm profit.

Item.	April 1, 1914.	April 1, 1915.
Farm inventory:		
Real estate.....	\$13,500.00	\$13,500.00
Live stock.....	2,729.00	2,883.00
Machinery and tools.....	475.00	461.00
Feed and supplies.....	658.00	836.00
Bills receivable.....	46.00	
Cash on hand and in bank.....	670.00	2,148.00
Total farm investment.....	18,078.00	19,823.00
Bills payable.....	2,000.00	1,500.00
Net worth each year.....	16,078.00	18,323.00
Increase in net worth.....		2,250.00
Cash account:	148.00	
Personal expenses.....	420.00	
Household expenses.....	100.00	
Interest on mortgage of \$2,000.....		668.00
Total money paid out for other than farm expenses during year.....		
Supplies and rent:		
Supplies furnished by farm to owner.....	120.00	
Rent of farmhouse (its value to owner).....	180.00	
Total supplies and house rent.....		300.00
Total farm gain.....		3,218.00
Interest and labor:		
Interest on average of total farm investment of \$18,953, at 5 per cent.....	947.65	
Unpaid family labor (estimated).....	300.00	
Owner's labor (estimated).....	480.00	
Total interest on investment, etc.....		1,727.65
Actual farm profit.....		1,490.35

The statement just presented gives the items which are needed and the method used in determining the farm profit. The first part shows the two complete farm inventories. The difference between them, which is \$2,250, represents the increase in net worth exclusive of household and personal goods. This increase includes the farm gain from the growth of live-stock, the amount of unsold produce, etc. During the year the farmer paid out of the funds received from the sale of farm products \$148 for personal expenses, \$420 for household expenses, and \$100 interest on the mortgage of \$2,000, making a total of \$668 paid for other than farm expenses. The owner also received from the farm, milk, butter, eggs and garden produce, the total value of which for the year is estimated at \$120. The rental value of the farmhouse to the owner must be counted as a farm receipt and has been estimated at \$180. The house has been included in the farm investment, and, as interest is charged on the total investment, the farm should be credited with the value of this house rent. The \$2,250 increase in net worth plus the \$668

paid out for other than farm expenses plus \$300, the value of the supplies and rent furnished by the farm, constitute \$3,218, the total farm gain.

The farmer had invested \$18,078 the first year and \$19,828 the second year, or an average of \$18,953. This investment should pay him a fair rate of interest before he can count any profits. Assuming the rate of interest to be 5 per cent per annum, the interest charge is \$947.65; deducting this charge from the farm gain leaves \$2,270.35, which represents the amount that the farmer and his family made during the year. The owner's family, who did some work on the place during the year, were not paid in cash, and the value of their labor should be deducted before showing profits. In this instance it is estimated at \$300; subtracting this estimate from the \$2,270.35 leaves \$1,970.35, which amount can be called the farmer's labor income, or the amount of money that he earned on the farm during the year after all expenses except his own labor were deducted. To find the net farm profit the owner must be paid for his own labor, which in this case is estimated at \$480 for the year. This sum deducted from \$1,970.35 gives a farm profit of \$1,490.35. The last item, and no other, is the actual farm profit.

After determining the total farm profit or the labor income, the natural question arises as to the exact standing of each enterprise on the farm. This means a tabulated statement of the expenses or cost and the receipts or income of the crops and live stock on the farm. The first step in such statement is a summary of the cash account. This is merely a cash statement showing total yearly expenses and receipts for each enterprise. From this statement and other data will be made up the individual crop and stock reports. For the average farmer it is not essential or advisable to go into detail accounting and distribution of building, equipment, and overhead charges to the various crops. If the principal costs of land-interest or rent, labor, seed, twine, threshing, and cash costs are apportioned a very fair knowledge of costs and profits will be gained. The value of many systems of farm accounting is often lost, because of the labor and detailed knowledge of bookkeeping required to close the year's business into an understandable statement. Without a statement that is understood, and that is reasonably simple of compilation, the year's work in keeping the data will be wasted.

Such a table will give the essential costs and tell the farm operator the approximate cost per acre, the yield per acre and the cost and profit per bushel or ton. All the costs of the crop are not included, such as machinery, manure, taxes, building charge, and overhead expense but on the other hand there is no credit value given to the straw of the grain crops.

The following illustrates a simple form that can be ruled up by any one and the various costs supplied from the various records kept during

the year. This assumes the keeping of a labor record. The same form may be used and this item estimated from published bulletins.

CROP COST TABLE

Crop	Field	No. Acres	Man Labor Cost	Horse Labor Cost	Seed Cost	Twine Cost	Thresh Cost	Total Direct Cost	Assum'd Land Rent Per Acre
Corn.....	A	40	\$180.00	\$160.00	\$20.00	\$360.00	\$3.50
Oats.....	B	30	54.00	75.00	45.00	\$6.00	\$27.00	207.00	3.50
Wheat.....	C	30	55.00	75.00	42.00	6.00	13.20	191.20	3.50

Crop	Direct Cost Per Acre	Total Cost Per Acre	Total Yield Bu.	Yield Per Acre	Value-Grain Per Acre	Profit Per Acre	Loss Per Acre	Profit Per Bu.	Loss Per Bu.
Corn.....	\$9.00	\$12.50	2000	50	\$25.00	\$12.50	\$0.25
Oats.....	6.90	10.40	900	30	10.50	0.10	0.033
Wheat.....	6.37	9.87	330	11	8.80	\$1.07	0.097

Diagram for Above Cost Table

- Cost Figures Taken from
- Field and Acreage..... Farm map or sketch.
 - Labor cost..... Labor record or published data.
 - Seed Cost..... "Seed used" record or cash account.
 - Twine Cost..... Cash account and twine inventories.
 - Threshing Cost..... Cash account—(Charge at the cost per bu. in figuring for each crop.)
 - Land Rent or Interest..... Cash rent or estimated rental value.
 - Yield..... "Crop acreage and yields" record.

While estimates are used in such figures the bases for them are sound and far better than no figures on the crop costs. For those who desire to make up a separate statement of each crop in detail, such as is possible in cost-accounting investigations, the following statement may serve as an example:

Account with a crop of corn in field B (36.48 acres) on an Iowa farm, 191—

Items of statement.	Date.	Total—			Per acre—			Per bushel.
		Man hours. ²	Horse hours. ²	Cost.	Man hours. ²	Horse hours. ²	Cost.	
Plowing, fall of 1909 (14-inch gang).....	Mar. 25 to Apr. 2....	85½	342	\$46.48	2.34	9.38	\$1.279
Disking.....	Apr. 7 to 29.....	90½	361	49.28	2.47	9.89	1.351
Harrowing.....	Apr. 29 to May 4....	25½	51	8.56	.70	1.40	.235
Planting (with planter).....	Apr. 30 to May 5....	30½	61	10.25	.84	1.67	.281
Harrowing (after planting).....	May 10 to 14.....	33½	72½	11.86	.92	1.99	.325
Cultivating (first time).....	May 27 to 30.....	58	116	19.49	1.59	3.18	.531
Cultivating (second time).....	June 3 to 6.....	54½	109	18.31	1.49	2.99	.502
Cultivating (third time).....	June 14 to 18.....	51½	103	17.31	1.41	2.82	.474
Cultivating (fourth time).....	June 23 to July 5....	57	114	19.15	1.56	3.12	.525
Picking seed corn.....	Sept. 27 to Oct. 7....	59	7.44	1.62204
Husking (from standing stalks).....	Nov. 2 to 22.....	305½	611	102.65	8.38	16.75	2.814
Total labor cost.....	851	1,940½	310.98	23.32	53.19	8.524	..
Manure charge.....	124.91	3.424
Seed, 5½ bushels, at \$5.....	27.50751

Account with a crop of corn in field B (36.48 acres) on an Iowa farm 191—Continued.

Items of statement.	Date.	Total—			Per acre—			Per bushel.
		Man Hours. ²	Horse Hours. ²	Cost.	Man hours. ²	Horse hours. ²	Cost.	
General expense.....				18.24			.500	
Equipment.....				23.27			.638	
Taxes.....				25.53			.700	
Interest (rent).....				255.35			7.000	
Total cost.....				785.78			21.54	
Summary:								
Income ³				1,127.36			30.90	\$0.512
Cost.....				785.78			21.54	.357
Profit.....				341.58			9.36	.155

¹ Previous crop: Timothy for seed.

² Rates per hour: Man hours, 12.6 cents; horse hours, 10.5 cents.

³ Yield: 2,200 bushels of grain, at 50 cents (average, 60.3 bushels per acre), \$1,100; stalks, \$27.36; total, \$1,127.36.

In addition to the labor cost the table shows certain other charges against the crop, namely, the cost of seed, the value of manure used (only part of which is charged to the corn crop, the remainder being charged to later crops), the use of implements and machinery, general expenses, taxes and land rental or interest on the investment in land. The total of all these charges gives the total cost of growing the corn up to the time it is put in the crib. The equipment cost, or the charge for the use of machinery, is difficult to determine accurately. In this illustration the equipment charge was arrived at through carefully kept records.

The live stock statements are of great importance but owing to their widely differing costs and receipts, it is more difficult to place the statement in collective tabular form than the crop statement. For purposes of study it is preferable to make a statement of each class of stock at the end of the year. The important features of a live-stock statement are the costs, made up of decrease in inventory, feed, labor and cash; and the receipts, made up of increase of inventory, cash taken in, produce used in the household and stock products fed to live stock. These items require the keeping of inventories, cash accounts, production records and if possible the household record. In other words, it means keeping the essential records as outlined at the beginning of this article. Here, again, it is not possible, probably, for many farmers to ascertain some of the minor costs such as shelter, taxes, equipment charge, manure credit and others. If one can obtain the feed and labor costs and keep a careful inventory the results will be accurate enough for all practical purposes.

The above figures for a statement may all be obtained from the records when compiled for the year. The increase or decrease in inventory is taken from the two inventories; the cash costs, such as

new purchases, medicine, etc., are taken from the cash account; the feed cost and amounts of feed from the feeding records; the labor from labor records or assumed costs from published data that is applicable. The receipts are obtained either from the cash account as actual cash, or from the annual production of butter fat, pork, beef, eggs, etc. The latter method requires the use of an average farm price per unit in order to transform the figures into cash. If the farm produce used in the house is not recorded this may be estimated and included as a stock receipt. If the total annual production is taken, as mentioned above, the amount consumed in household and that fed to stock need not be considered. Such a statement would appear something as follows:

CATTLE STATEMENT

Average Number of Head 30 cows. Average Number of other cattle, 21 Head.	Year 19—	
	Decrease or Costs	Increase or Receipts
Opening inventory, 30 head.....	\$1,005.00	
Closing inventory, 52 head.....	4,260.00	\$255.00
FEED—Ground Feed 54500 lbs. @ \$1.01 cwt.....	550.06	
Silage 86.8T. @ 3.00.....	265.79	
Hay 32.5T. @ 7.54.....	245.06	
Corn Fodder 2.5T. @ 4.50.....	11.25	
Pasture.....	104.00	
Total.....		\$1,236.16
LABOR—5088 hours man labor @ 15c.....	\$763.20	
593 hours horse labor @ 10c.....	59.30	
CASH EXPENSE Stock.....	\$150.00	822.50
Medicine.....	22.15	
CASH RECEIPTS—Cream.....	\$1,744.62	
Stock.....	860.00	
Fed to stock.....	230.00	
Used in household.....	140.00	\$2,974.62
Totals.....		\$2,230.81
Gain over feed and labor.....		998.81
		\$3,229.62
		\$3,229.62

The above statement is sufficient for all practical purposes yet it would not answer for a complete account with a class of live stock, for all the costs and receipts are not included. The table on the following page shows the items included in such an account. Some are easily determined; others are estimates, and the accuracy of the final result depends largely on the accuracy with which these estimates are made. It is seen that the estimated value of the manure is about one-third of the final profit. The data as given in the table are an approximate yearly record on a large dairy farm.

The value of live-stock statements that show the facts in their true light cannot be overestimated. Many dairy farmers delude themselves by thinking that because their cows pay for their feed they are profitable, but such is not the case. It is also true that many cows were they put on a production record test, would find their way to the

butcher shop rather than remain in the costly barn of the farmer, consuming costly feed. It is also important to know that the profit made by producing the feed is not lost when fed to live stock. The real facts are that there are no good arguments against the keeping of such records on the farm.

Outline account for one class of live stock: Dairy herd.

Data.	Item	Subtotal.	Total.
Inventory:			
Jan. 1, 1910—			
Live stock—47 cows, 3 bulls.....		\$2,725.00	
Equipment.....		409.30	
Total.....			\$3,134.30
Jan. 1, 1911—			
Live stock—38 cows, 2 bulls.....		2,395.00	
Equipment.....		373.60	
Total.....			2,768.60
Difference (decrease).....			365.70
Receipts:			
Milk and cream (225,689.3 pounds).....	\$3,630.29		
Cows sold.....	1,521.60		
Bulls sold.....	117.60		
Calves sold (34).....	227.60		
Total receipts.....			5,497.09
Expenses:			
Mixed hay, 26.5 tons.....	212.00		
Alfalfa hay, 10.71 tons.....	128.57		
Silage, 163.28 tons.....	673.15		
Grain, 34.38 tons.....	835.12		
Pasture, 7 months.....	275.86		
Total feed cost.....		2,124.70	
Man labor, 8,819½ hours, at 12 cents.....	\$1,058.34		
Horse labor, 1,443½ hours, at 10 cents.....	144.35		
Total labor cost.....		\$1,202.69	
Feed for bulls.....	80.33		
New equipment.....	5.23		
Repairs on equipment.....	1.31		
Salt.....	13.70		
Advertisements.....	22.50		
Miscellaneous (general expenses, etc.).....	49.05		
Decrease in inventory.....	365.70		
Total miscellaneous expenses.....		537.82	
Total expenses.....			\$3,865.21
Difference between receipts and expenses.....			1,631.83
Interest at 5 per cent on average investment in cattle and equipment.....		147.56	
Building charge, \$6 per cow per year.....		255.00	
			402.56
Balance.....			1,229.32
Add estimated value of manure.....			641.05
Profit.....			1,870.37

SOME RESULTS OF COST INVESTIGATIONS

One of the important problems of the average farm is the management of the horse labor so as to gain maximum efficiency at minimum cost. Another problem along the same line is to keep the cost of

producing the farm products at a minimum while obtaining the maximum yields per acre, cow, sow, etc. This does not mean producing such a large yield as to abnormally increase the cost of production, for this may result in a smaller profit than lower or average yields at a low cost. Each farmer should have a working knowledge of the cost of producing his products so as to know the limits of production, both the minimum and the maximum.

Annual Cost of Maintaining a Farm Work Horse— Few farmers realize that the annual cost of keeping a farm work horse approximates one hundred dollars. The cost varies with the feed price, the care and management of the horse and the credit earned by colt raising. Many people think that a colt foaled and reared to one year of age is clear credit for the mare. This is not true; the service fee plus the feed and care required usually consume considerably over half the value of the colt. The efficiency in horse labor lies in providing profitable labor for the horses at all seasons with the result of keeping the horse rate per hour at the minimum.

Carefully gathered records from Minnesota farms indicate that the rate on average farms is about ten cents per hour. From an average of twenty-four farms covering five years the annual cost of maintaining a farm work horse varied from \$84.16 in northern Minnesota to \$103.41, in the southeastern part of the state. The horses averaged 1,040 hours of labor annually with a daily average per work day of 3.46 hours. This resulted in an average rate per hour of 9.2 cents. On many farms this rate will be increased while on those that provide more labor the rate will be lowered.

Cost of Producing Field Crops—The importance of knowing the cost of producing the farm crops that are commonly grown cannot be overestimated. If every farmer knew the cost per acre and therefore the cost per bushel, the average yields would be increased, for there are not the compensating profits in average yields that there should be to make the business successful. To serve as an example the following figures are quoted from Bulletin 115 of the Minnesota Experiment Station:

AMOUNT OF PRODUCT NECESSARY TO COVER COST OF PRODUCTION, 1908-1912

Crop	Average Cost	Average Farm Price Dec. 1, 1908-1912	Product Necessary
	Per Acre	Per Bu.	Bu.
Spring wheat, fall-plowed	\$10.78	\$0.898	12.00
Oats, fall-plowed	12.02	.352	34.14
Barley, fall-plowed	11.16	.586	19.04
Rye, stack-threshed	10.83	.630	17.19
Flax, stack-threshed	10.70	1.604	6.67
Corn, husked	14.52	.478	30.37
Hay, timothy, and clover	\$7.51	Per Ton \$7.760	Ton .96

Cost of Raising and Maintaining a Dairy Cow—From five-year records in Wisconsin it was concluded that the average net cost of a dairy heifer one year old is \$39.52. This cost is made up of its initial value, \$7.04; feed, \$24.67; labor, \$4.45, and other miscellaneous costs, \$6.36; total, \$42.52; credit for manure, \$3.00. The average net cost of a dairy heifer two years old was found to be \$61.41, the feed cost having risen to \$40.83; labor, \$7.81, and other costs, \$13.73, with a manure credit of \$8.00. (Figures from U. S. Department Bulletin 49).

It can be seen that a heifer entering the dairy herd must be worth about \$60 to cover the cost of production. After becoming a cow the cost of maintaining the animal varies considerably. The feed ration, based on the amount of milk produced is again the largest item, although the labor cost is increased to an important item. Minnesota Bulletin 124, which covered five years of carefully collected and tabulated data, states that under average Northwest conditions the annual cost of maintaining a cow approximates \$60. In the rural districts of the Central West and in the eastern part of the United States feed prices are higher, especially roughage, and the cost is increased to from \$75 to \$100 per year.

AVERAGE COST IN NORTHWEST OF MILK AND BUTTER FAT (BULLETIN 124)

Year	Milk per cwt.	Butter Fat, per lb.
1905	\$1.11	29.2 cents
1906	1.22	32.0 cents
1907	1.31	34.1 cents
1908	1.27	33.3 cents
1909	1.25	34.3 cents

SUMMARY

No attempt has been made in the foregoing pages to treat the subject in an exhaustive manner. It has been the aim rather to deal with as simple a record as possible and yet at the same time have the results of sufficient value to be of use to the farmer. The trained agricultural student or the business-college graduate will no doubt desire a more detailed system than has been outlined here, and in this desire he is perfectly justified. But the average farmer is not a trained book-keeper, and the very nature of his work is such that it is hard for him to do clerical work. After being in the field all day or out in a cold biting wind, it requires considerable exertion to write up a set of accounts in the evening. The farmer is trained to do physical work and, although he is intelligent and capable when it comes to deciding important matters, it is difficult for him to do clerical work of this character. When physically tired it is doubly difficult to do such work as adding a column of figures. Farm bookkeeping is a matter of adapting simple methods to the farmer's needs. It is not a question of forms or having the accounts on the right side of the page or of

having them balanced in a certain way, but it is a question of a correct knowledge and understanding of the facts as they exist on that particular farm.

The interpretation of the figures at the end of a year or period of time is far more important than keeping the record. Merely setting down a mass of figures may be worse than no record, while a few figures properly kept that tell a definite story may be very valuable. This is usually true of the farm inventories which require but little time. Aside from the intrinsic value of the knowledge afforded by well kept records, a certain interest and incentive in the farm business is inevitable. Such an interest works mightily for the increasing of efficiency, the elimination of waste and the increasing of the net income which makes for better business and better farm homes. These, in the end, are the aims of all well directed agricultural development.

CHAPTER II

REPLANNING A FARM FOR PROFIT

I. INTRODUCTION. II. HOW FARMS ARE REPLANNED BY THE OFFICE OF FARM MANAGEMENT—GENERAL CONSIDERATIONS—FUNDAMENTAL POINTS—PLAN No. 1—A GRAIN AND HAY FARM—PLAN No. 2—A GRAIN AND CLOVER-SEED FARM—PLAN No. 3—A GRAIN AND CLOVER FARM—PLAN No. 4—A SHEEP FARM—PLAN No. 5—A HOG FARM—PLAN No. 6—A DAIRY FARM. III. SUMMARY OF RETURNS FROM DIFFERENT TYPES OF FARMING—PLANS GIVEN NOT MODEL. IV. FIELD MANAGEMENT—NATURAL FIELD DIVISIONS—FENCING.

INTRODUCTION

In presenting this chapter on replanning the farm for profit, we will consider the subject matter under two distinct heads. First: the reorganization or readjusting of the different farm enterprises so as to secure greater incomes, either by adding new and more productive lines or by increasing the income of the old and well established departments. Second: the rearrangement of the fields to meet these demands.

One of the greatest difficulties the American farmer has to overcome is the inability to break away from old and time-worn customs. Habit frequently continues a type of farming in a community long after that type has become unprofitable. For instance wheat farming in the United States on new, cheap and virgin soil is generally very profitable, but there are many farmers who continue to grow wheat after it has ceased to return a profit.

Methods of farming that are known to be behind the times, the relics of early pioneer days, are allowed to stand because the farmers do not have the necessary capital to make a change, or because it is human nature to follow the lines of least resistance.

It was not until the land became exhausted of much of its fertility and land prices began to rise, that many farmers came face to face with the fact that they must change their methods or go out of business. It might be well here to mention briefly some of the agencies that would make farming unprofitable and reorganization necessary: High priced land and low yields, making it impossible for the farmer to pay operating expenses and at the same time to earn the interest on his investment; losses in handling farm machinery and labor on irregular and poorly shaped fields; losses from unproductive pasture lands and from long continued cropping to small grains and corn; and taxes or perhaps interest paid on rough or undrained land which is unproductive. Sometimes live stock is kept at a loss, because the farmer does not

know, through lack of an accounting system, whether his stock is a source of income or an expense. The kind of stock to keep because of the owner's personal liking, or the ability to produce certain feeds cheaply and abundantly, are all questions of vital importance in considering the question of farm reorganization. Again the question of a market is often the deciding factor.

At best the problem of replanning a farm to give the greatest degree of profit is a big one. In many states the experiment stations have departments of farm management, where each farmer of that state can go for help on his own particular problem. The United States Department of Agriculture is always ready and willing to help if the required information cannot be obtained from the state experiment station.

How Farms are Replanned by the Office of Farm Management—The Office of Farm Management of the Bureau of Plant Industry at Washington, D. C., has undertaken the replanning and reorganization of many farms in different parts of the country and for the purpose of illustration and to show the different ways in which the reorganization may be considered, one of their plans with some modifications is here shown.

The farm consists of 80 acres located in central Illinois. The owner stated that his farm was located on the black prairie corn land common to that section of the state, that it was valued at \$150 to \$175 an acre, would rent for \$5 an acre cash, and that it had been cropped with corn and oats for many years until the average yields were about 35 bushels of corn per acre or 20 bushels of oats.

In one year the actual yields were 24 bushels of corn and 12 bushels of oats per acre. The total income of the whole farm, estimating crops at average prices, was less than \$150 for the year, from which it will be readily seen that the labor and capital invested are not very handsomely rewarded. In fact, if the labor on the farm were hired the farm would be run at a considerable loss. Valuing the farm at \$12,000, the interest alone at 5 per cent is \$600.

This farm was chosen for illustration because it is typical of large farming areas in parts of the middle states and because the price of the land has outgrown the system of farming in vogue.

In the future management of this farm three propositions are open to the owner: (1) Continue the old method of farming and lose money; (2) rent the land out at \$5 per acre cash and permit the land to be further robbed of soil fertility and impoverished; and (3) change his plans to meet the new conditions and farm rationally and profitably.

In replanning this farm it was decided as a preliminary to make general estimates of the returns that might be expected if the farm were operated along any one of the following lines:

(1) A grain and hay farm, with a three-year rotation of corn, oats, and hay.

(2) A grain and clover-seed farm, with a three-year rotation of corn, oats, and clover for seed.

(3) A grain and clover farm, with a four-year rotation of corn, oats, and clover.

(4) A sheep farm.

(5) A hog farm.

(6) A dairy farm.

General Considerations in Replanning the Farm—Among the first things essential to know in replanning a farm is what can reasonably be expected from the farm if properly handled. Judgment on this point will be considerably influenced by what is being done by good farmers on similar land elsewhere under like conditions.

The usual crops grown in the vicinity and the usual rotation on most of the farms of the neighborhood are corn and oats. But very little hay is raised, notwithstanding both clover and timothy do well, nor is much stock fed. Some colts are raised, but most of the grain is sold direct to the elevator.

In the early days, when the land was new, corn yielded 75 to 80 bushels per acre and oats 40 bushels, and this type of farming—corn in rotation with oats—was very profitable. At the present time on similar land and within 10 miles of the farm in question, one extensive farmer has been able to maintain the average yield of both corn and oats for a period of sixteen years at 40 bushels per acre. Even on this farm scarcely 15 per cent of the area is yearly planted to clover, and no commercial fertilizer and practically no stable manure is used.

With a proper system of rotation, the introduction of clover into the farming scheme, and the use of comparatively small quantities of commercial fertilizers where barnyard manure is not available, it should be easily possible to make the average yields of corn on this farm 60 to 75 bushels per acre and of oats 40 to 45 bushels.

This estimate is based on the fact that in a thirty-year rotation experiment at the University of Illinois the yield of corn in a rotation of corn, oats, and clover has averaged 58 bushels per acre, and when treated with lime and phosphorus in addition for thirteen years the average yield of corn per acre has been 90 bushels. Our first thought, therefore, in replanning this farm is to introduce clover into the rotation and to use some form of commercial fertilizer that will maintain the fertility of the soil and increase the yield of money crops.

Some Fundamental Points to Be Kept in Mind—In replanning a farm it is essential that a few fundamental points in farming be kept constantly in mind:

(1) The plan should provide a reasonable reward for the labor and capital invested.

(2) The fertility of the farm should be maintained or increased.

(3) The plan must be suited to the capabilities of the owner for carrying it out.

It is assumed that in order to replan a farm for profit it is necessary to consider the capabilities of the farmer to put the new plan into effect. This, in general, will render it necessary to recombine the phases of farming with which he is already familiar or to bring in new features which are not very dissimilar to the ones he is already accustomed to. That is why in plan 1 the only change made is the addition of clover to the rotation, with a little bone meal to increase the corn crop.

PLAN 1.—A GRAIN AND HAY FARM

Live Stock to Be Kept—To successfully handle an 80-acre farm of heavy soil on which corn, oats, and hay are grown, about three work animals will be needed. These may well be draft brood mares, and it may safely be assumed that two colts a year will be produced. To supply the family with milk and butter, about two cows will be needed. The farmer will probably raise two or three hogs for pork and will keep a few chickens. It is assumed that the permanent pasture for two cows and two colts during the season, and possibly two or three hogs, depending on whether it may or may not be cheaper and less troublesome to buy pork than to put up hog fences and feed corn, together with the buildings, garden, and orchard, will require about 8 acres (ordinarily a cow requires 2 acres of pasture each season), thus leaving 72 acres of the farm which can be put into cultivated crops.

Rotation to Be Followed—These 72 acres will be divided into three fields of 24 acres each without division fences, and a three-year rotation of crops will be observed as follows:

One 24-acre field will be planted with corn, using selected seed and fertilizing the field with all the barnyard manure available, and in addition applying about 400 pounds of steamed bone meal per acre. As this land still produces a luxuriant crop of clover no lime will be added at present other than that contained in the bone meal. The corn crop will be cultivated, not necessarily the regulation three times and then laid by, but as often as may be necessary to keep the upper 2 or 3 inches of soil loose, mellow, and free from weeds. The corn will be planted on a clover sod which has been plowed down in the fall and left rough through the winter.

The second 24-acre field will be planted to oats, or possibly winter wheat, as winter wheat is again coming into favor with farmers in the section. The oats will be put in on corn ground which has been thoroughly disked and put into fine condition for this crop. No fertilizer will be used on the oats. Selected seed of the Swedish Select

variety or of some other variety that does well in the neighborhood will be sown. With the oats and ahead of the drill a mixture of about 6 pounds of common red clover and 8 pounds of timothy will be sown.

The third 24-acre field will be in hay, the timothy and clover mixture seeded with the oats the preceding year.

Yields to be Expected—In this first replanning of the farm, then, provision has been made for a three-year rotation of corn, oats, and clover, each to occupy the same field but one year before that field is refitted for another crop in the rotation. The total average yields that may be expected from this rotation after it is put into operation are about as follows:

Corn, 24 acres, at 60 bushels per acre (bushels).....	1,440
Oats, 24 acres, at 40 bushels per acre (bushels).....	960
Hay, 24 acres, at 2 tons per acre (tons).....	48

The second crop of clover hay should be plowed down for humus and nitrogen.

Feed Requirement for Stock—However, all of the product cannot be sold. The stock must be fed and for the purpose it is assumed that the following quantities will be required through the year for the different classes of live stock:

	Pounds
3 mares, 15 pounds oats, daily.....	16,425
2 colts, 2 pounds oats daily, for 300 days.....	1,200
2 cows, 4 pounds of oats daily for 210 days.....	1,680
Poultry, estimated amount fed.....	320

Total oats fed to all live stock.....19,625

	Pounds
2 cows, 2 pounds corn daily, for 210 days.....	840
Poultry, estimated amount fed.....	500
2 hogs, estimated amount fed.....	1,680

Total corn fed to all live stock.....3,020

Very little hay will be fed as the corn will all be cut and all the straw and fodder will be used for feed and bedding—however, with no pasture for horses and a limited pasture for cows, some hay will be required; six tons should be sufficient.

If this farm were being planned for the greatest profit instead of for the purpose of showing the various ways in which the problem may be attacked, less grain and more clover hay would be fed. In fact, all the hay produced on the place would be fed to stock of some kind bought or raised for the purpose.

Financial Returns to Be Expected—There will be required for use on the farm the following feeds and seed for the year: 613 bushels of oats, and for feed and seed about 60 bushels, making a total of 673 bushels; about 55 bushels of corn will also be used. The remainder of the oats grown, together with 1,386 bushels of corn and most of the

hay, 2 colts and probably 2 veals may be sold each year and together with poultry sales and poultry products, will constitute the gross income of the farm. The gross returns may be expected to be about as follows:

Corn, 1,386 bushels, at 50 cents a bushel.....	\$ 693.00
Oats, 287 bushels, at 40 cents a bushel.....	114.80
Hay, 42 tons at \$8 a ton.....	336.00
2 colts at \$50 each.....	100.00
2 calves at \$5 each.....	10.00
Poultry, estimated returns.....	123.00
Total gross income.....	\$1,378.80

From the \$1,378.80 gross income should be deducted the cost of about 5 tons of steamed bone meal at \$25 a ton, leaving a balance of \$1,253.80 as the gross returns, out of which must come the expenses of labor, living, interest on investment, etc.

The Effect of Adopting Plan 1—In this first outline plan it is seen that by the introduction of hay, a large part of which is clover, into the rotation, thus augmenting the humus and nitrogen content of the soil, and by the addition of 100 pounds to the acre of steamed bone meal on each crop of corn, it may be expected that the yields will be doubled and the income raised from less than \$450 to \$1,253.80 a year, with all expense charges remaining practically the same as before, and in addition \$125 paid out for steamed bone meal to help maintain the fertility of the farm. These results would not be secured the first year. The fertilized corn crop would first show the results of the system and not until the third year could the above results be expected.

The nearly 11 tons of grain fed, together with the 24 acres of oat straw and 24 acres of corn stover fed or used as bedding on the place, will make approximately 100 tons of manurial material to be used on the corn. This, with the plowed-under second crop of clover, will keep the farm fairly well supplied with humus. The 400 pounds of bone meal used on the corn, with that furnished by the manure, will more than supply the phosphoric acid removed by all the crops, and the only element of importance permanently decreased in the soil is potash. There is such an abundant supply of potash, however, in most corn soils that this factor can probably be neglected for several generations yet.

The income of \$1,253.80 per annum by the system of farming outlined in Plan 1 will pay only 5 per cent interest on a \$15,000 investment and leave but \$493.80 to pay taxes, running expenses, labor, etc., so further changes will be made as suggested in the following plan.

PLAN 2.—A GRAIN AND CLOVER-SEED FARM

In Plan 1, just described, the usual system of operating the 80-acre farm was modified in only one important particular. The rotation of corn and oats was changed to a three-year rotation of corn, oats, and

clover and timothy hay. The hay was sold for \$8 a ton. Instead of selling the hay, suppose only clover seed is sown—either mammoth, common red, or alsike—and the whole crop saved for seed. How would this change affect the income and fertility of the farm?

The live stock kept on the farm would be 3 brood mares, 2 cows, and 2 colts, as before. The method of feeding them would be the same. One man could do practically all the work on the farm, as before. The 400 pounds of bone meal per acre would be applied on the corn crop each year, but instead of attempting to put up or market hay, only clover seed would be sown and attention centered on the production of a heavy clover-seed crop. The rotation would be (1) corn, (2) oats, (3) clover for seed.

Possibilities of Clover-Seed Farming—What are the possibilities of clover seed as a standard farm crop? As commonly handled—the first crop cut for hay and the second crop taken for seed—the average yields vary from a peck to occasionally 2 bushels per acre. Thus handled, clover seed is a precarious crop and there is practically no money in it. But farmers are known in Ohio and Illinois who make a business of growing clover for seed each year and who count with as much certainty on getting yields of 4 bushels of seed per acre as they do on getting 50 bushels of corn per acre each year on good corn land.

To secure seed the clover-seed farmer aims to make his clover bloom in dry weather. He reduces the quantity of stem, and instead of a rank-growing plant that lodges badly he will have a short, stocky, upright clover plant. Likewise he aims to have only a medium thick stand of clover on the field when he grows it for seed, and so will use much less seed at planting time than when the crop is grown for hay. And probably most important of all, the successful clover-seed farmer will make his clover bloom at a time when the insects which injure the seed most are for the most part undergoing their transformations in the ground.

Usually all of the results referred to are accomplished by pasturing the clover back to about June 1 to 10, or clipping the clover with the mower at about the same time and letting the clippings lie on the ground. It is not usually possible to get both a good hay crop and a good clover-seed crop the same season. Generally the hay crop must be sacrificed or cut considerably earlier than usual.

An instance is known of a 50-acre field of clover in Illinois, not far from the 80-acre farm here being considered, where haying was begun one season about ten days earlier than usual and finished about the usual time. The whole of the second crop was then saved for seed. On the part cut earliest for hay the seed obtained at the second cutting averaged close to 5 bushels per acre for common red clover. On that portion of the field cut last for hay the seed yield of the second crop

was scarcely 1 bushel per acre. By cutting hay early the ravages of the clover-flower midge, which prevents clover-seed formation, were largely avoided and a good seed crop obtained.

Financial Returns to Be Expected — In the second plan it is assumed that if a farmer understands his business he can get average yields of at least 3 bushels of clover seed per acre. Assuming yields of 60 bushels of corn per acre and 40 bushels of oats, as before, that the stock will require the same quantity of feed as in Plan 1, and that prices will be 50 cents per bushel for corn, 40 cents for oats, and \$6 for clover seed, there will be for gross income the following:

Corn, 24 acres, 1,386 bushels, at 50 cents.....	\$ 693.00
Oats (feed and seed, 673 bushels), 287 bushels at 40 cents.....	114.80
Clover Seed, 24 acres, 72 bushels, at \$6.....	432.00
2 colts at \$50 each.....	100.00
2 calves at \$5 each.....	10.00
Poultry, estimated returns.....	125.00
Total Income.....	\$1,474.80

From this gross income of \$1,474.80 will be deducted \$125 for 5 tons of bone meal, leaving \$1,349.80 to pay for labor, interest on investment, and other charges against the farm.

The growing of the clover for seed instead of for hay is thus seen to be even more profitable than the hay proposition. The labor of harvesting the seed is much less exacting than handling the crop for hay, and if a rain or two should come after the seed crop is cut the damage is far less than in the case of the hay crop.

Besides, instead of the hay being sold, resulting in considerable loss of soil fertility to the farm, all the clover straw and chaff would be returned to the fields and the fertility of the soil maintained much more surely than by Plan 1.

It is thus seen that by simply modifying the present system of corn and oat growing on this farm by the addition of clover grown for either hay or seed the gross income is more than doubled and the land greatly improved at the same time. The returns from this system of farming will just about pay 5 per cent interest on a \$15,000 investment and moderate wages to one man for the year. It would not satisfy the man who had bought a farm and was trying to pay for it out of the proceeds of the farm.

PLAN 3.—A GRAIN AND CLOVER FARM

If the crops grown on this farm and the prices received for them are examined critically, attention is attracted at once to the fact that the largest return per acre, \$30, is secured from the corn crop. From the standpoint, therefore, of profit and the use of the crops here under consideration it is desirable to grow as large an acreage of corn each year as is consistent with good farming.

Some of the important factors that must be kept in mind in increasing the acreage of corn are the insects that affect the crop injuriously when grown too many seasons on the same field in succession, the necessity of maintaining the nitrogen and humus supply in the soil by the culture of some leguminous crop, and the supplying of adequate amounts of certain mineral fertilizers, like the phosphates, to secure maximum corn crops and insure the continued productiveness of the farm.

Rotation to Be Adopted—A rotation which has been found satisfactory and effective in parts of the corn belt and which puts half the farm in corn each year is as follows: (1) corn, (2) corn, (3) oats, (4) clover. This is a four-year rotation in which half the fields are in corn each year. It is true that in this rotation corn follows corn for two years, but this is not particularly objectionable on good corn ground, especially when, following corn, the field is given two years' rest from this crop and opportunity is thus afforded to free the land from the more serious pests of the corn. This is also a type of farming differing but little from that already in operation on the farm under consideration, and hence easy to adopt.

If it be assumed, as in previous plans, that 8 acres of the farm are devoted to buildings, yards, garden, orchard, and permanent pasture for the cows, colts, and calves, there will remain 72 acres to fit into this four-year rotation. These 72 acres, therefore, may be divided into four 18-acre fields and each year there will be grown (1) 18 acres of corn, (2) 18 acres of corn, (3) 18 acres of oats, and (4) 18 acres of clover. The corn will be fertilized each year with about 400 pounds of steamed bone meal per acre.

Live Stock to Be Kept and Yields to Be Expected—As in previous plans, it is assumed that the stock kept on the farm will be 3 brood mares, 2 colts, 2 cows, and 2 hogs. It has already been shown that to feed the fixed stock on the farm, about 19,625 pounds of oats will be needed. In feeding the grain and for seed, practically all the oats grown on the farm, about 720 bushels, will be needed, and about 56 bushels of corn in addition. The roughage and bedding for stock will consist of corn stover, about 6 tons of clover hay and oat straw. The clover may be handled either for seed or hay.

As the hay crop in the hands of the ordinary farmer is a little more certain than the seed crop, this phase will be considered in making the final calculations. The average yield expected will be as follows:

Corn, 36 acres, at 60 bushels per acre (bushels).....	2,160
Oats, 18 acres, at 40 bushels per acre (bushels).....	720
Clover hay, 18 acres, at 2 tons per acre (tons).....	36

Financial Returns to Be Expected—Of the oats, 40 bushels will be used for seed and all the remainder fed. Of the 2,160 bushels of corn,

all but 56 bushels will be sold. About 30 tons of the clover hay will be sold. The average gross returns of the farm from all sources should be about as follows for the four-year rotation:

Corn, 2,104 bushels, at 50 cents.....	\$1,052.00
Clover hay, 30 tons, at \$8.....	240.00
2 colts at \$50 each.....	100.00
2 calves at \$5 each.....	10.00
Poultry, estimated returns.....	125.00
Total	\$1,527.00

The amount of bone meal bought for the corn will be increased from 5 to 7 tons, which will cost about \$175, leaving \$1,352.00 as a return for the year's expenses, interest, and labor.

If the clover were harvested for seed instead of hay the returns for the clover crop would be \$324 instead of \$240, and in addition all the clover straw, which is worth as a fertilizer practically \$8 a ton, would be left on the land as a permanent improvement instead of being sold off for hay.

This plan yields a gross return of 5 per cent interest on \$15,000 investment and leaves a balance to pay taxes, running expenses and salary for manager of from \$602 to \$686.

To show the effect of making live stock the leading feature of the farm, plans showing the returns that may be expected by certain methods of handling different classes of stock will now be taken up.

PLAN 4.—A SHEEP FARM

Of all the different types of agriculture, live-stock farming is the surest way known to increase yields and keep up permanently the fertility of the farm or to build up the farm after it has once been run down by years of grain, cotton, or tobacco farming. The owner of the 80-acre farm here under consideration was conscious of this fact and thought possibly he might go into some kind of stock farming. Would it pay? He liked sheep; people said there was "money in sheep." He desired that in replanning the farm its possible conversion into a sheep farm be considered. To meet this request, therefore, the farm has been planned along one of the more usual lines of sheep farming common to Illinois to see about what returns might be expected.

Live-Stock Farming a Complex Problem—The introduction of stock on the farm complicates matters considerably in planning a cropping system which shall fit the needs of the stock kept and in estimating expenses and returns. First of all, in the present instance, it is necessary to know how many sheep an 80-acre farm will carry. Before this question can be answered it must be known roughly how much "fixed stock," like horses and cows, will be kept on the place, since it will require a certain amount of land to grow crops for this "fixed stock," and

it is only the area that is left that can be counted on for pasture and crops for the sheep. In the previous plans, where an excess of grain and roughage was grown, the acreage of crops required for the fixed stock did not necessarily enter into the problem except as regards final returns. Now, however, the number of fixed stock kept and what they eat will be a limiting factor on the number of sheep that can be kept, and must be known at the outset.

In order that the plan for the farm may be in a measure complete with the plans previously outlined it will be assumed at the outset that 3 brood mares will be kept for farm work, 2 colts raised yearly, 2 cows kept for family use, and 2 calves sold for veal.

Good sheep farming presupposes the growing of considerable clover or other leguminous hay. With clover hay for feed, an efficient ration for practically all this stock can be made, with corn as the principal grain ration. Some oats, perhaps, should be grown for the colts and cows, and some will be needed in starting lambs on grain rations, but as corn weighs more per bushel and yields more bushels per acre than oats, it is desirable to use corn instead of oats whenever possible.

Feed Requirement for Stock—The fixed stock on the place will be fed about as follows:

	Pounds
3 horses, 15 pounds of corn daily for year.....	16,425
2 cows, 2 pounds of corn daily for 210 days.....	840
Poultry, estimated amount fed.....	560
Total corn fed to all live stock.....	17,825

	Pounds
2 cows, 4 pounds oats daily, for 210 days.....	1,680
2 colts, 2 pounds of oats daily for 300 days.....	1,200
Poultry, estimated amount fed.....	320
Total oats fed to all live stock.....	3,200

	Pounds
3 horses, 5 pounds of hay daily for a year.....	5,475
2 cows, 10 pounds of hay daily for 210 days.....	4,200
2 colts, 5 pounds of hay daily for 180 days.....	1,800
Total hay fed to live stock.....	11,475

The above data indicate that for the fixed stock there will be required yearly 17,825 pounds of corn; 3,200 pounds of oats, and 11,475 pounds of hay.

With this type of farming, in which all of the crops grown on the farm are consumed on the farm and where clover will constitute the principal hay and pasture crop, it is assumed, as in previous plans, that the yields will be 60 bushels, or 3,360 pounds, of corn; 40 bushels or 1,280 pounds, of oats; and 2 tons of clover hay per acre on the average each year.

Acreage Required to Support Fixed Stock—With the above data in

hand it is possible to determine the amount of land that will be required to support the fixed stock on the farm. This is shown in the table below.

TABLE No. 1
ACREAGE OF CORN, OATS, AND HAY REQUIRED BY FIXED STOCK

Kind of feed required	Total quantity required	Yield of 1 acre	Total area of each crop required
	Pounds	Pounds	Acres
Corn	17,825	3,360 (60 bushels)	5
Oats	3,200	1,280 (40 bushels)	2.5
Hay	11,475	4,000 (2 tons)	2.8
Total acreage required		10.3

This table shows that 10.3 acres of the farm must be devoted to growing hay and grain for the fixed stock. If to the 10.3 acres of corn, oats, and hay required for the fixed stock 8 acres more are added for the buildings, orchard, garden, and permanent pasture for the cows, colts, and pigs, there will be left for sheep only 61.7 acres of the farm. The problem now is: How many sheep will this area support? What is the maximum number of ewes that can be maintained on this area and what are the average returns that may be expected per annum?

To answer these questions it is first necessary to find out how much land will be required to support one sheep. This, in turn, depends on what the sheep eats, and so at the outset it is found necessary to adopt a feeding system and plan of management for the flock.

Flock Management and Feeding System—Good grade Merino-Shropshire ewes will be used and pure-bred bucks of either the Shropshire, Oxford, Hampshire, or Southdown breeds. It is assumed that on the average each ewe in the flock will drop one lamb. It is planned to have the lambs dropped in February and sold the last of June or first of July, at a weight of from 40 to 50 pounds. This will avoid carrying the lambs through the hot summer months, when pastures are short, gains slow, and danger from infestation by stomach worms great. Besides, the ewes will be relieved by weaning the lambs at this season of the year and more pasture will be available for grazing; hence, more ewes can be kept and the ewes will be in better condition for September and October breeding.

The general scheme of feeding ewes and lambs will be about as follows:

Ewes. The ewes will run at pasture from May 1 to November 30, and it is assumed that an acre of good clover pasture will support about 4 ewes with their lambs. From December 1 to April 30 the ewes will receive about 3 pounds of clover hay daily, and in addition during the

month of February, when the lambs are coming, each ewe will be fed about 1 pound of oats daily, while during March and April the same quantity of grain will be fed the ewes with the idea of thus increasing the growth of the lambs, but half the grain will be oats and the other half corn.

Lambs. The lambs will run with the ewes up to the time they are sold, and from March 15 to June 30 will each receive daily on the average about three-eighths of a pound of corn until sold the latter part of June or early in July.

The total quantity of grain and hay that will be required for each ewe and her lamb during the year will be about as follows:

Ewes:	Pounds
Hay, December 1-April 30, 151 days, fed 3 pounds daily....	453
Oats, February 1-28, 28 days, fed 1 pound daily.....	28
Oats, March 1-April 30, 61 days, fed ½ pound daily.....	30.5
	58.5
Corn, March 1-April 30, 61 days, fed ½ pound daily.....	30.5
Lambs:	
Corn, March 15-June 30, 107 days, fed ¾ pound daily.....	40.1
	70.6

Acreage Required to Support Each Ewe and Her Lamb — As shown, each ewe and her lamb will require during the year a total of 453 pounds of hay, 58.5 pounds of oats, and 70.6 pounds of corn. In addition it has been assumed that they will also require one-fourth acre of pasture. The total area of land, then, required for each ewe and lamb for grain, hay, and pasture will be as shown in the following table:

TABLE No. 2
ACREAGE OF CORN, OATS, HAY, AND PASTURE REQUIRED BY EACH EWE AND HER LAMB
DURING A SEASON

Kind of feed required	Total quantity required	Yield of 1 acre	Total area of each crop required
	Pounds		Acres
Corn.....	70.6	3,360 (60 bushels)	0.021
Oats.....	58.5	1,280 (40 bushels)	.046
Hay.....	453.0	4,000 (2 tons)	.113
Pasture.....			.250
Total acreage for each ewe and her lamb.....			.430

In the above table the figures showing acreages in the last column are obtained by dividing the amount of feed required for each head by the quantity that can be produced on an acre. They show that there must be grown for each ewe and her lamb 0.021 of an acre of corn, 0.046 of an acre of oats, 0.113 of an acre of hay, and 0.25 of an acre of pasture, or a total of 0.43 of an acre for an ewe and her lamb.

Number of Ewes the Farm Will Carry — It has already been shown that the area required for the fixed stock, buildings, permanent pasture, etc., was 18.3 acres, thus leaving 61.7 acres of the farm for sheep, and since one ewe requires but 0.43 of an acre for her support, 61.7 acres will carry as many ewes as 0.43 is contained in 61.7, or 143, leaving off the fraction. It is assumed that three bucks will be needed for a flock of ewes of this size and that the bucks will require about the same feed as the ewes. It will therefore be safe to figure on a permanent flock of about 140 ewes and 3 bucks.

Acres of Crops to be Grown for Feed — In replanning this farm as a sheep farm only such crops will be grown as the sheep and other live stock require. The acreages devoted to each of the crops of hay, pasture, oats, and corn are easily determined by multiplying the amount of each crop required for one ewe and her lamb, as shown in Table No. 2, by the total number of mature sheep kept on the place, or 143, and adding these results to the acreages required by the fixed stock as shown in Table No. 1. In the following table these calculations are made.

TABLE No 3
ACREAGE REQUIRED FOR THE MAINTENANCE OF 143 SHEEP AND FOR THE FIXED STOCK

Kind of feed required	Area required for 1 sheep	Area required for whole flock	Area required for fixed stock	Total area of each crop grown
	Acres	Acres	Acres	Acres
Corn.....	0.021	3.	5.	8.
Oats.....	.046	6.57	2.5	9.
Hay.....	.113	16.18	2.8	18.9
Pasture.....	.250	35.7	35.7
Total acreage required				71.6

The last column of the above table shows that to meet the requirements of the sheep and fixed stock on the farm there should be grown each year about 8 acres of corn, 9 acres of oats, 18.9 acres of hay, and 35.7 acres of pasture, or 71.6 acres in all, in addition to the 8 acres of land devoted to buildings, orchard, and permanent pasture for cows and colts.

Rotation to be Followed — For all practical purposes, these 72 acres might be divided into four 18-acre fields and four-year rotation adopted as follows: (1) corn and oats (10 acres of corn, 8 acres of oats, and the whole field seeded to clover and timothy), (2) hay, (3) pasture, and (4) pasture. This rotation would supply each year 10 acres of corn, 8 acres of oats, 18 acres of hay, and 36 acres of pasture, which is practically what is needed by the stock kept.

This rotation calls for the seeding of clover in the corn at the last cultivation. Should the catch fail, a mixture of oats and field peas will be sown on the corn land the following spring and cut for hay.

A mixture of clover and grasses should be seeded with the peas and oats to furnish pasture the following season.

Another rotation and arrangement of fields which would meet the needs of the sheep as regards crops and pasture would be as follows: (1) 9 acres of corn, (2) 9 acres of oats, (3) 9 acres of mixed clover hay, (4) 9 acres of mixed clover hay, and (5) four 9-acre fields of permanent or semi-permanent pasture. The objection to this plan is the increased liability to stomach-worm diseases resulting from too long continued pasturing on the same fields.

Financial Returns to Be Expected—Having planned this farm as a sheep farm and having arranged to handle the flock by a method common on Illinois farms, the returns that may be expected from this type of farming may be considered. The sources of income and the gross returns that may be expected are about as follows:

140 lambs, at \$4 each.....	\$ 560.00
143 fleeces, at \$1.50 each.....	214.50
2 colts at \$50 each.....	100.00
2 calves at \$5 each.....	10.00
Poultry, estimated returns.....	125.00

Total returns\$1,009.50

These returns are not particularly attractive, though nearly double what the farm is now paying. They hardly pay wages and interest on the investment. Had the owner not done some such preliminary figuring as here recorded, he might have gone into the sheep business somewhat along the usual lines, as outlined above, to his considerable disappointment.

Pasturage Responsible for Low Returns—An examination of the crop acreages required to support this flock of 143 sheep indicates the reasons for the comparatively low returns from this type of farming. Comparatively low-priced crops are grown. More than half the farm is in pasture. One-fourth of it is in hay. This is too large a proportion of high-priced land in cheap crops for profit.

There are other types of sheep farming much better adapted to this high-priced land. If a four-year rotation of corn, oats, hay, and pasture were adopted, only half the number of sheep kept, and the surplus grain and hay sold, the income would be increased from \$1,009.50 to \$1,186.50.

Again, if a four-year rotation of (1) corn, (2) corn, (3) oats, and (4) clover for hay were adopted cowpeas sown in one cornfield at the time of planting, rape sown in the other at the time of laying by the corn, the first crop of clover cut for hay and the second used for pasture, and a good quality of western lambs bought in September at the average Chicago price for the past five years (\$5.87) and pastured on the clover, cowpeas, rape, and standing corn, then fed clover hay and corn until February and sold at the average Chicago price for the past five

years (\$7.44), the income from the farm after deducting the usual expenses for freight, commissions, etc., would be about \$2,065. This increased return is due primarily to the fact that three-fourths of the farm each year is in grain, while during the latter part of the season practically the whole farm is used for pasture. This system of sheep farming, besides taking more than \$2,500 extra capital for purchase of lambs, requires executive ability of a high order. It serves, however, to bring out the value of studying carefully the type of farming one is following for profit.

PLAN 5.—A HOG FARM

The returns that may be expected on this 80-acre farm from making hogs the main source of income and by following one of the better plans of hog raising will now be considered.

Pasture Crops Desirable for Hogs—A bushel of corn fed to hogs on a dry lot or in a pen will produce on an average 10 pounds of pork. The same corn fed in connection with bluegrass, clover, or other suitable pasture will produce 30 per cent more pork; besides the hogs will be healthier, and there will be much less danger from disease in the pastured hogs.

In replanning the 80-acre farm here under consideration as a hog farm, therefore, suitable pasture crops will be provided throughout the season. An acre of clover pasture or its equivalent should carry, when at its best, 12 to 20 hogs. In the present plan it is assumed that each brood sow on the farm will have one litter of 6 pigs a season, probably in April, and that 15 bushels of corn will carry a sow a year or produce a pig weighing 200 pounds by December.

Cropping Plan—While a ewe and her lamb in the farm system presented in Plan 4 will scarcely eat 130 pounds of grain a season, two pigs will eat 1,680 pounds of grain, or more than twelve times as much as the sheep. Sheep are primarily grass eaters. Hogs economically consume large quantities of grain. At the outset, then, it is seen that a hog farm must provide an abundance of grain, and in central Illinois that grain is corn.

In order, therefore, to grow as large an area of corn as possible and still follow a rotation of crops that will not permit of corn being planted on the same field oftener than two years in succession, with two years intervening before another corn crop is planted on the same field (for reasons that have been explained in Plan 3), only one-half of the farm at most can be put into corn in a four-year rotation.

If there is set aside, therefore, as in all the plans heretofore considered, about 8 acres for the house, barn, orchard, garden, and permanent pasture for the cows, calves, and colts, there will remain 72 acres on which to grow crops for the fixed stock and the hogs.

This area may be divided into four fields of 18 acres each and a rotation followed of (1) corn, (2) corn, (3) oats, and (4) clover, exactly as discussed in Plan 3. The important difference in the two plans is that instead of selling off the corn, as in Plan 3, it will be fed on the place. The grain will be made into pork and the farm built up in productiveness considerably more rapid than where all the corn is sold.

In the management of the fields the following general plan will be followed: One field of corn will be drilled in rows instead of check-rowed and with the corn will be planted about a peck of cowpeas. At the last cultivation of the corn a mixture of rye and rape will be sown in the corn to furnish additional green feed for the hogs in the fall. With the aid of movable fences this field of corn, cowpeas, rye, and rape will be harvested by the hogs themselves, the hogs being turned into the field early in September of each year.

The following year this field of corn, enriched by the planting of cowpeas, the pasturing off of the whole field with hogs, and the plowing under of the excess stubble and straw, will again be planted to corn. The third year the field will be seeded to oats and clover and the oats cut for grain. The fourth year the field will be in clover. A part of the clover will be pastured by hogs, part will be cut for seed, and a portion of the field plowed and seeded to a mixture of sorghum and rape for midsummer pasture, as outlined in detail farther along in this chapter.

Conditions Assumed — In this plan, as in the others, it is assumed, in accordance with reasons previously stated, that by the use of 400 pounds of bone meal or its equivalent per acre on the corn and the growing of clover or an equivalent legume crop on the land once every three or four years in systematic rotation, the corn yield can be made to average on the farm in question 60 bushels and oats 40 bushels per acre.

For this type of farm also, as in previous plans, about 3 work mares, 2 cows, 2 colts, 2 calves, and in addition 1 boar will be kept.

Feed Requirement for Stock —

	Bushels
Oats for feed.....	613
Oats for seed.....	40
	—
Total oats used.....	653
Corn, for boar.....	15
Corn, for poultry.....	10
Corn, for cows.....	15
	—
Total corn used.....	40

Number of Brood Sows that Can be Kept — Thirty-six acres of corn are grown in all and only 1 acre of it is required for seed and for extra feed for the fixed stock. It will therefore be safe to calculate roughly

on about 35 acres of corn that may be fed to hogs. But it has been assumed that each brood sow and each of her 6 pigs will consume on the average 15 bushels of corn; therefore the total quantity consumed by 1 brood sow and litter—7 pigs in all—will be 105 bushels. At 60 bushels of corn per acre 105 bushels represents 1.75 acres of corn required for each brood sow and litter; 35 acres of corn land, then, will support 20 brood sows and their litters.

Pasture for Hogs—From the time clover pasture is ready in the spring until about June 1 the hogs will be pastured on 5 acres of an 18-acre field of clover fenced off with a temporary hog fence. Up to about June 1 the suckling pigs running with the sows do not need much pasture, and this 5 acres of young clover will furnish them and the sows all they will need. After removing the hogs from this 5 acres the clover will come on and later be cut for seed. About June 1 the hogs will all be transferred to 7 acres of clover adjacent, now in prime condition for pasture, and kept on it until about July 15.

To furnish fresh prime pasture for the hogs from about July 15, when the clover is past its prime, up to the time when the corn is ready to be hogged off, 6 acres of the 18-acre clover field will be plowed up about May 1 and planted in sorghum and rape. About July 15 the temporary fence next to this sorghum and rape pasture will be removed and the hogs given the run of the pasture they are already on and in addition the 6 acres of sorghum and rape. This will furnish ample green feed for the hogs until September 15, when all but the sows will be turned in on a portion of the 18-acre cornfield planted with peas and later sown to rye and rape.

The corn plant will have considerable feeding value for the hogs in September, but as the stalks become more woody the cowpeas, rye, and rape will furnish the necessary green feed and the corn and cowpeas will furnish the grain. As the hogs clean up one portion of the cornfield the portable fence will be moved and another portion added, and by the time the entire field is cleaned up the hogs will be ready for market.

In handling the clover crop for seed it is quite desirable that the clover be pastured off until about June 1 in central Illinois. The 5-acre field of clover that the hogs were pastured on earliest in the season has been handled so as to fulfill this condition, as shown in Plan 2; therefore it may be cut for seed in late August. After the clover field has been cleared of the hogs which were turned into the cornfield and after the clover for seed has been harvested, the sows may be given the run of the entire 18-acre field until cold weather or until the field is plowed in the fall for the next year's crop.

Financial Returns to be Expected—The gross returns that may be expected from the 80-acre farm as here planned are about as follows:

120 hogs, 200 pounds each, at 5½ cents.....	\$1,320
5 acres of clover seed, 15 bushels, at \$6.....	90
2 colts, at \$50 each.....	100
2 calves, at \$5 each.....	10
Poultry (estimated amount).....	125

Total gross returns.....\$1,645

From this total must be deducted for the first few years about \$175 each year for bone meal for the corn, leaving \$1,470 to pay interest on the investment, wages, and expenses.

One of the interesting features of these results is that they are about \$443 better than when the farm is handled in the ordinary way as a sheep farm. Another fact worth noticing is that while the returns for hogs are not much greater than where the farm is run in a similar way without hogs, all the corn is fed on the place. This practice, together with the practice of sowing cowpeas, rape, and rye in the corn and pasturing it off, will tend rapidly to build up the farm, so that in time even larger yields of crops than here assumed would be easily possible.

It will also be noticed that each field has a leguminous crop on it three out of the four years over which the rotation runs and that the field of corn that was hogged off has practically everything that was grown on the land left on it. The fertilizer bill may be reduced materially and at the same time the yields largely increased. The labor of gathering the corn is saved, and the experience of some of the most successful hog raisers demonstrates that there is not enough waste of grain in this method of harvesting to offset the wages for the necessary labor to gather the corn. Most of the labor on this farm can be performed by one man. The necessary extra equipment for hog raising on the farm is comparatively inexpensive. This type of farming is very attractive to a great many farmers because usually the hog requires less attention than most other farm animals.

For a detailed account of a successful 80-acre hog farm in Illinois on which the annual income available for general expenses, family income, etc., was \$2,284, see Farmers' Bulletin 209.

PLAN 6—A DAIRY FARM

General Considerations on Dairy Farming—With good cows and good management dairy farming is one of the most profitable types of stock farming; but with poor cows and ordinary management there is no money in dairying.

It is not profitable to pasture cows on high-priced land and sell butter for 25 cents a pound; it requires too much land for pasture, about 2 acres for each cow kept.

Feeding silage to dairy cows the year around has been found to be as satisfactory as regards milk yield and butter production as soiling in summer and silage in winter, and more convenient. By either of

these methods many more cows can be kept on a farm of given size and more profit made than by the pasture system.

The most frequent sources of loss in the dairy business are poor cows, low crop yield, and inadequate rations. Home-grown feeds usually need to be supplemented with such feeds as cotton-seed meal, gluten feed, or oil meal in compounding rations for dairy cows which shall result in maximum milk and butter production.

With purchased feeds and the manure handled properly and put back on the land, dairy farming is one of the most certain methods known for building up a farm to a high state of productivity.

Conditions Assumed—It is assumed that if a man is going into dairying he will read up the business and make a thorough study of all the details of good cows, effective rations, proper herd management, suitable cropping systems, efficient methods of caring for and applying manure, and other like factors of importance. It is assumed that he will keep a herd of well-bred grade dairy cows, each of which will produce 6,000 pounds of milk or make 280 pounds of butter a year.

Since it is difficult to buy cows of this type whenever wanted, it is assumed that heifers will be raised for the purpose, and that on the average there will be about one-fourth as many heifer yearlings and one-fourth as many heifer calves as there are milch cows, or in all one-half as many young stock as there are cows in the herd.

The problem is, How many cows with corresponding young stock will this farm of 80 acres support? To answer this it is first necessary to know how much fixed stock, like horses, colts, bulls, etc., will be kept and what this fixed stock, the young stock, and the dairy herd will be fed.

Fixed Stock on Dairy Farm—As in previous plans, it will be assumed that 3 brood mares will be kept on the place and 2 colts raised each season, and one bull kept for herd use.

Feeding System for Stock—Horses and Colts—The horses, as heretofore, will be fed an average of 15 pounds of corn and 5 pounds of clover hay daily, with all the cornstalks they will eat throughout the year. The colts will be fed $1\frac{1}{2}$ pounds of clover hay for 120 days of the year and 2 pounds of oats for about 300 days.

Cows—The daily ration for the cows will average for the year as follows: 35 pounds of corn silage, 7 pounds of clover hay, 3 pounds of corn-and-cob meal, 2 pounds of oats, and 1 pound of cotton-seed meal. Corn stover in small amounts will be fed in addition.

The above combination of feeds will afford a well-balanced ration for cows giving 6,000 pounds of milk a year. All the grain will be grown on the place except the cotton-seed meal, or its equivalent, which will be bought. The grain will be mixed in about the proportions above indicated.

The quantity fed to one cow at any particular time will depend on the amount of milk the cow is giving. Roughly speaking, a pound of

mixed grain will be fed for every 3 or 3½ pounds of milk given. Thus, if the cow is giving 30 pounds of milk a day, 10 pounds of grain will be fed; if she gives only 15 pounds a day then only 5 pounds will be fed. The average for the whole year for one cow will be about as shown above.

Yearlings—The yearlings from about May 1 to October 31, 184 days, will run at pasture and will receive on the average about 4½ pounds of hay daily in addition. It is estimated that each yearling will require on the average 1 acre of pasture for its support. From November 1 to April 30, 181 days, the yearlings will be fed 12 pounds of silage, 10 pounds of hay, and 2 pounds of corn-and-cob meal daily.

Calves—The heifer calves that are kept will be allowed to run at pasture for about six months, or 180 days of the year, and one-half acre of pasture will be allowed for each calf. They will be fed in addition about 5 pounds of hay daily throughout the year. Supplementing the hay for about three months they will receive 6 pounds of corn silage. One pound of corn-and-cob meal per head will be fed for about six months of each year, with a little oil meal in addition. About 2,000 pounds of skim milk will be fed each calf raised.

Bull—The bull will be fed about 2 pounds of corn, 2 pounds of oats, a half pound of oil meal, 6 pounds of hay, and 25 pounds of silage a day.

Yields to be Expected—As in previous plans, average yields of 60 bushels of corn or 12 tons of silage, 40 bushels of oats, and 2 tons of hay per acre, when fairly started as a dairy farm, are assumed.

Acreage Required for Fixed Stock and for Buildings—The grain and hay required for the horses, colts, and one bull, and the land required to grow these crops on, calculated from the feeding data and assumed yields per acre previously given, are as follows:

Corn:	Pounds.	Acres.
3 horses, 15 pounds, 365 days.....	16,425	
1 bull, 2 pounds, 365 days.....	730	
Hogs and chickens (estimated amount).....	2,240	
Total corn	19,395	or 5.7
Corn silage:		
1 bull, 25 pounds, 365 days.....	9,125	or .380
Oats:		
2 colts, 2 pounds, 300 days.....	1,200	
1 bull, 2 pounds, 365 days.....	730	
Poultry (estimated amount).....	320	
Total oats	2,252	or 1.8
Hay:		
3 horses, 5 pounds, 365 days.....	5,475	
2 colts, 1½ pounds, 120 days.....	360	
1 bull, 6 pounds, 365 days.....	2,190	
Total hay	8,025	or 2.
Total area required for fixed stock		9.8

From the above table it is seen that about 6 acres of corn, 1.8 acres of oats, and 2 acres of hay, or a total of 9.8 acres of land, will be required to grow crops for the fixed stock on the farm. To this must be added the land devoted to orchard, garden, buildings, and exercise lot for the cattle, or about 4 acres, making in all practically 13.8 acres. This subtracted from 80 acres leaves 66.2 acres on which to support the cows and young stock of the farm.

The number of stock that this area will support may next be determined.

Number of Cows and Young Stock That Can be Kept — To determine how many cows and young stock can be kept on these 66.2 acres it is first necessary to determine how much land is required to keep one cow and one-half as much young stock.

Feed Consumed by One Cow and Corresponding Young Yearly — Based on the rations already assumed, the quantity of feed required by one cow and corresponding young and the acreage required to grow the same on the farm are shown in the following table:

TABLE No. 4
FEED AND ACREAGE REQUIRED FOR EACH COW AND CORRESPONDING YOUNG

Kind of Feed required	Cow (a)	Yearlings (b)	Calves (b)	Total feed required	Area corresponding to total feed required (c)
		Pounds	Pounds		Pounds
Corn silage.....	Pounds 12,775	Pounds 543.0	Pounds 135.0	Pounds 13,453.0	Acres 0.561
Corn and cob-meal.....	1,095	90.5	45.0	1,230.5	.293
Oats.....	730	730.0	.570
Clover hay.....	2,555	659.5	456.3	3,670.8	.918
Cotton-seed meal.....	365
Pasturage.....	Acres 0.25	Acres 0.125375
					2.717

(a) The amount of each feed required for a cow per year is obtained by multiplying by 365 the average quantity of feed consumed daily, as shown under "Feeding System for Stock."

(b) The quantity of feed required by the yearlings and calves corresponding to one cow will be the quantity fed, as shown in the rations assumed, multiplied by the number of days each feed is given, and the sum divided by 4, since there are only one-fourth as many yearlings and one-fourth as many calves as there are cows in the herd.

(c) The acreage of each crop required for one cow and corresponding young is determined by dividing the amount of feed required, as shown in column 4, by the yield per acre (as previously assumed) It is estimated, also, that 1 bushel of corn will produce 70 pounds of corn and cob meal, or 4,200 pounds per acre.

The last column of the above table shows that the area of land required to grow the crops for the maintenance of one cow and corresponding young is 2.717 acres. It has been shown that 66.2 acres of the farm are available for cows and young stock. This area will therefore support 24 cows.

Omitting the fraction for the sake of convenience, it may be assumed that the farm will support about 24 cows and 12 head of young stock and that it will produce all the grain and hay required for them except about 4.25 tons of cotton-seed meal or oil meal, which must be purchased at a cost of about \$32 per ton, or \$136.

Acreage of Crops Required for Feed — With the data given in the last column of Table 4, which shows the acreage of each crop grown for feed required for the support of one cow and corresponding young, it will be easy to calculate the acreage required for the whole herd. Thus, in the case of corn silage, if 0.561 acre is required for 1 cow and young, 23 cows will require 12.9 acres.

The acreage thus obtained for all the crops grown for the herd of 23 cows, as well as the acreages of the different crops required for the fixed stock on the place, as shown under that heading, are given in the following table:

TABLE No. 5
ACREAGE OF CROPS REQUIRED TO BE GROWN ON THE FARM

Kind of feed required	Acreage required for each cow and corresponding young	Acreage required for herd	Acreage required for fixed stock	Total acreage to be grown
	Acres	Acres	Acres	Acres
Corn silage.....	0.561	13.46	0.38	13.84
Corn for grain.....	.293	7.03	5.7	12.74
Oats.....	.570	13.68	1.8	15.48
Clover hay.....	.918	22.	2	24.03
Pasture.....	.375	9.	9
Total acreage.....	65.17	75.09

From the last column in the above table it will be seen that it will be necessary to grow on the farm each year for the herd and fixed stock 13.84 acres of corn for silage and 12.74 acres of corn for grain, or 26.58 acres of corn in all, 15.48 acres of oats, 24.03 acres of clover hay, and 9 acres of pasture.

Rotation to be Followed — For practical purposes of rotation it may be assumed that the acreages required for the different crops in round numbers are as follows: Corn, 26 acres; oats, 15 acres; hay, 24 acres; pasture, 9 acres; total, 74 acres. While on a dairy farm, where an abundance of stable manure is available, systematic rotation is not so essential as on a grain farm, yet rotation is always good farm practice. In the present instance it will be easy to fit the crops required to a four-year rotation. For this purpose the 74 acres may be divided into 4 fields of 18½ acres each and the following cropping plan adopted on each field:

First year, 18½ acres of corn, well manured.

Second year, 18½ acres of oats, 4 acres cut for hay, whole field seeded down.

Third year, 18½ acres of hay.

Fourth year, 18½ acres — 9 of pasture, 2 of hay, and 7½ of corn.

This scheme would require movable fencing for the 9-acre pasture.

Financial Returns to be Expected — The gross returns that may be

expected from a dairy farm on which 24 good cows are kept may be estimated about as follows:

280 pounds of butter from each of 24 cows, at 25 cents.....	\$1,680
100,000 pounds of skim milk, at 20 cents per hundred-weight....	200
16 calves, at \$5.00 each.....	80
2 colts, at \$50 each.....	100
Poultry receipts	125
Total gross income	<u>\$2,745</u>

From this gross income must be deducted \$136 for cotton-seed meal or oil meal, leaving \$2,609 as a gross return for the 80-acre dairy farm.

If milk were sold instead of butter and 4 cents a quart received, the returns would be about as follows:

61,000 quarts of milk, at 4 cents.....	\$2,440
16 calves, at \$5.00 each.....	80
2 colts, at \$50 each.....	100
Poultry receipts	125
Total gross income.....	<u>\$2,745</u>

Deducting from this gross income \$136 for concentrated feed, as before, leaves \$2,609 to pay the expenses, interest, and labor of the farm. The calves that are kept will about offset the decreased value of the herd from year to year.

Labor Item on a Dairy Farm—While these returns for the dairy farm appear larger than for any other type of farming they are not so in reality, because it requires more labor on this type of farm than on any of the types previously considered. It will require the labor of the owner and one other man the year around, and during the growing season at least, or about seven months of the year, a second man will have to be employed. The cost of this extra labor to the owner will be at least \$10 a month, including board, for each hired man, or about \$760. This would reduce the gross income from the farm when butter is made from \$2,609 to \$1,289, and when milk is sold, from \$2,609 to \$1,819. At 5 cents a quart the gross income after deducting these same items would be \$2,459.

Increased Investment Necessary in Dairy Farming—A further item necessary to take into consideration in the dairy type of farming is the considerable increase in investment necessary. Each cow in the herd of the character here planned for costs at least \$75. The cows, with the bull and young stock, represent an investment of at least \$2,000. To this must be added a suitable stable and about two 90-ton silos, which would represent an investment of at least \$1,500. In addition, a silage cutter, a milk separator, and other equipment would make in all an extra investment for dairy farming over the ordinary grain type of nearly \$1,000. It is a system, however, in which the returns begin

to come in at once and furnishes a cash income uniformly throughout the year.

Increased Productiveness of a Dairy Farm—While the labor bill and the investment are necessarily considerably increased in dairy farming, there is also a compensating feature. As all the crops grown on the farm are fed on the farm and additional grain bought and fed besides, the productiveness of the farm after the system has once fairly been put in operation will tend gradually to increase. In time every acre of land on the farm ought to be capable of producing an average of 90 bushels of corn or 3 tons of hay to the acre. This would permit an increase in the size of the herd, so that the profits would increase as the plan was continued.

SUMMARY OF RETURNS FROM DIFFERENT TYPES OF FARMING

A brief survey may now be taken of the differences in income which may be obtained from the same farm from the six different types of farming herein outlined. In all the types considered one man would be able to do practically all the work of the farm, except in rush seasons and in the case of dairy farming, and in one phase of sheep farming where two and sometimes three men would be required. Had the owner of the farm two or three sons to help him, more intensive types of farming than here outlined would have been planned.

The gross income from each of the different types of farming, after deducting the cost of fertilizers or feeding stuffs, is assembled below for comparison.

Farm as managed at present.....	\$ 450.00
(1) Farm planned as a grain and hay farm, three-year rotation	1,253.80
(2) Farm planned as a grain and clover-seed farm.....	1,349.80
(3) Farm planned as a grain and hay farm, four-year rotation...	1,352.00
(4) Farm planned as a sheep farm:	
(a) Pasture system.....	1,021.50
(b) Small flock.....	1,186.50
(c) Lamb feeding.....	2,065.00
(5) Farm planned as a hog and clover-seed farm.....	1,470.00
(6) Farm planned as a dairy farm:	
(a) Butter, sold at 25 cents (less extra labor).....	1,289.00
(b) Milk, sold at 4 cents a quart (less extra labor).....	1,849.00
(c) Milk, sold at 5 cents a quart (less extra labor).....	2,459.00

An examination of the figures shows the returns for the different types to vary from \$450 as now managed to \$2,459 per annum in the case of dairy farming, indicating a wide variation in the returns possible from the same farm by different systems of farming. These data emphasize the importance of studying closely the organization of a farm and the plan on which it is operated. If a corn-and-oat rotation of crops brings in but \$450 a year and by the use of clover and a little

fertilizer the returns can be increased by \$600 or \$800 without additional machinery or hired help, then a revision of the system of farming would seem worth while. By combining some of the types here considered and by introducing other modifications the returns might be still further increased.

Generally speaking, grain farming with a rotation of crops and the intelligent use of fertilizers is about as profitable a type of farming as any of the ordinary forms of stock raising. The following facts, however, should be considered in this connection. The fertilizer bills in the grain and hay types of farming must be indefinitely continued, and as the years go by will probably have to be revised. Quite certainly lime will be needed in addition to the phosphates applied if the yields assumed are maintained. On the other hand, in the live stock types of farming, particularly dairy farming, the fertilizer bills will grow less instead of increasing, while at the same time the land will be growing more productive, and instead of average yields of 60 bushels of corn and 2 tons of hay per acre, considerably larger yields than these may be confidently expected.

Plans Given Not Model Plans—The plans suggested in this chapter are neither complete nor are they models to follow. Their purpose is to show primarily that the income from the same farm can be doubled, trebled, or often quadrupled, by simply changing the system of farming and dropping the crops or practices that do not pay and substituting for them something that does pay.

The real purpose of the plans here made in some detail, is to illustrate various ways of thinking about the farm when the time comes for replanning it for profit; and to show ways of going at the problem of estimating the stock that can be kept, and the returns that may be expected to result, from the adoption of a given type of farming.

It would be easy to modify in a hundred different ways each plan given by the introduction of other crops, by varying the combinations of crops, by emphasizing the poultry industry or the orchard, by combining hogs with dairy cows, and so on. The plans given in this chapter, however, will serve their purpose if they suggest ways of looking at the problem and of estimating returns.

FIELD MANAGEMENT

The Natural Field Divisions—The modern farm originally consisted of one large field. Sometimes this field was all one level stoneless and treeless area, and sometimes it consisted partly of level, tillable land and partly of timber-covered, stony or rough and hilly land. Large areas of swamp or waste land sometimes prevented the forming of regularly shaped fields.

When the first farmer occupied the land it was necessary, in order

to make a living for himself and family and to grow feed for his stock, that some of the land be brought under cultivation as soon as possible. Naturally in such cases he plowed those areas that were most easily plowed, and left unplowed those fields that were hard to cultivate because of the presence of stones, stumps, sloughs, or hills.

Thus it is easy to see that the shape and size of the field was determined in a very large measure by the natural contour of the land, without any regard to the convenience of working. The number, size, and shape of these fields would depend on the number, size, and shape of those areas that were most easily cultivated.

After these field lines were once established they were not changed from generation to generation. It is not an uncommon thing to find

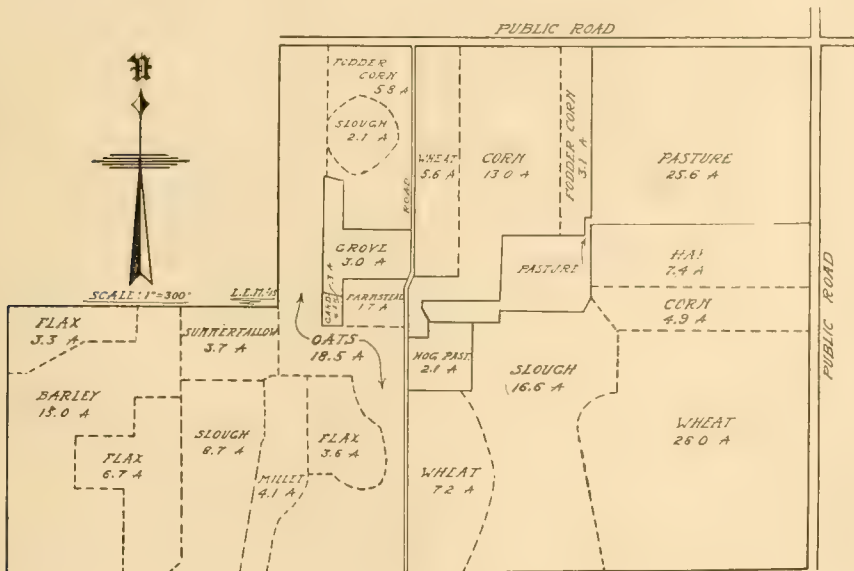

Fig. 1.—An Old Farm with over 20 Irregular Fields.

a farm having as many as twenty-five different fields. Very few farmers realize the tremendous loss of time and labor incidental to the cultivation of a large number of small irregularly shaped fields.

Crop rotations require a definite field arrangement. Before a definite and permanent rotation can be adopted, the farm must be divided into a given number of fields and these fields should be approximately uniform in size.

Fig. 1 represents a farm that has been farmed for over 30 years; on the farm are found twenty fields, all of them irregular in shape and varying in size from 2.1 acres to 28 acres. The presence of three sloughs makes it impossible to convert all the land into cultivated fields without a system of drainage. However, that is no good reason why so many

small irregular fields should be used. The unsystematic and haphazard field arrangement found on this farm shows a lack of forethought and careful planning.

Fig. 2 represents the same farm and a possible field arrangement without going to the expense of draining the sloughs. This provides for the same acreage of the different crops to be grown and the field arrangement is better.

Fig. 3 represents the same farm and a possible arrangement after the sloughs are drained, and a practical five-year rotation established, with plenty of hog pasture land and room for a minor rotation. In this plan the solid lines represent fences. It will be seen that all fields are

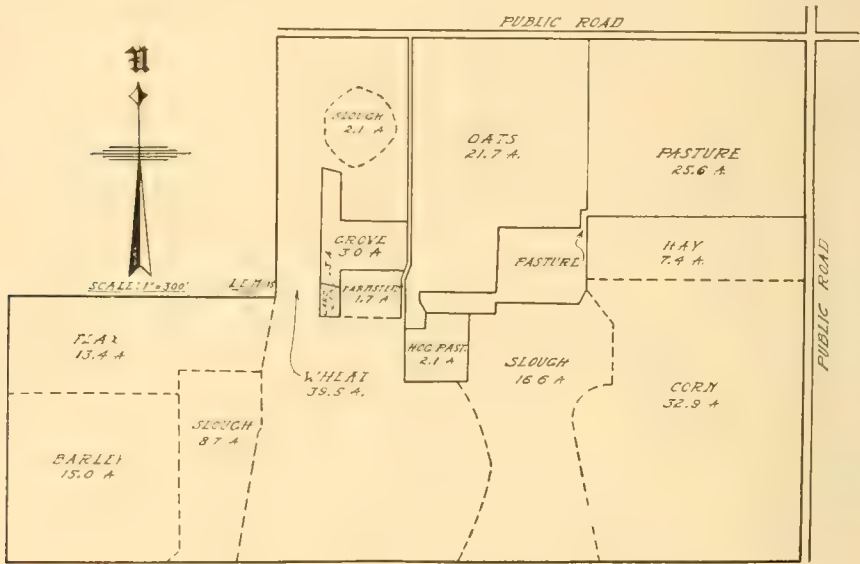

Fig. 2.—What Can Be Done Without Drainage Investment.

fenced, thus making it possible to utilize any waste grain by pasturing stock in the fields.

Five regularly shaped fields take the place of the twenty irregularly shaped fields, shown on plan No. 1. The crop acreage is very much increased. In place of 2.1 acres of hog pasture that has been used for that purpose for 10 to 12 years, plan No. 3 provides 15 acres of hog pasture that can be planned into a 3 or 4 year rotation.

In place of the 25.6 acres of wild pasture that had been pastured since the farm was settled and consequently furnished a very small amount of feed as compared with the same acreage in a good rotation, we find from 30 to 36 acres of good tame pasture.

The hay crop as provided in plan No. 1 was very uncertain. The farmer could not depend on any great quantity of hay; for, in some

wet seasons it was impossible to cut much in the sloughs, and about all the hay there was to be had was grown on the continuous wild hay meadows of 7.4 acres. In plan No. 3 from 30 to 36 acres of hay are provided each season, which should furnish 60 to 70 tons at a conservative estimate. In fact under this plan every acre of land is being used under a systematic rotation and if live stock enough is kept, the yields should increase instead of decrease, as they certainly would under the first field arrangement.

Fencing — One of the big advantages to be gained by a permanent rotation plan is that the field lines are permanent, thus making it practical to fence each field. As the fields are arranged on plan No. 1, their number, shape and size make it impractical to fence. It requires 1,410

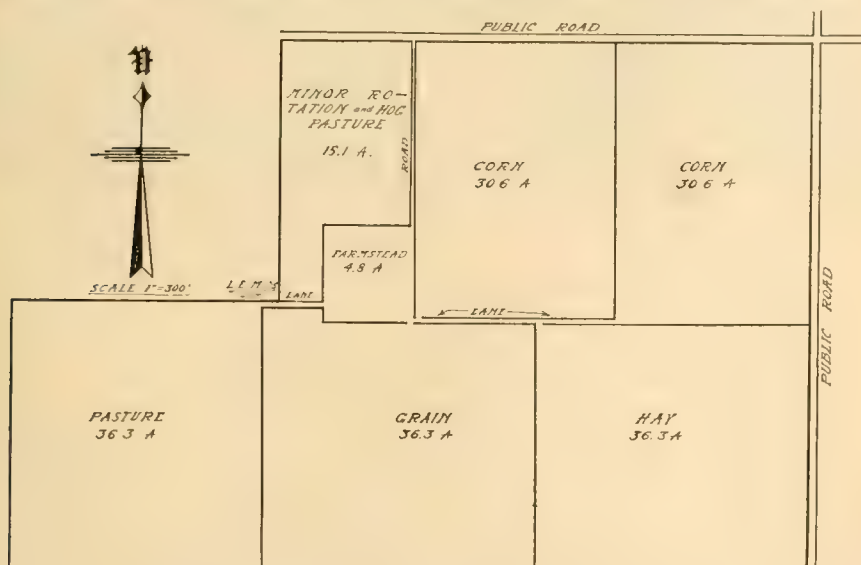

Fig. 3.—The Same Farm After Drainage.

rods for pasture and line fences alone; while plan No. 3 requires 1,431 rods (an increase of 21 rods) to fence all its fields. In arranging fields for rotation the cost of fencing should be considered.

Long narrow fields require more fence per acre to enclose them than do short or more nearly square fields. If possible all fields should be accessible from one central lane, and the lane should be as short as possible. The fact that fences cost money must not be lost sight of, and that unless some use of a fence can be made it is an unnecessary expense; the interest on the investment and the depreciation of a fence makes a fixed charge upon each and every acre enclosed, and unless this charge is more than equalled by benefits derived the fence should not be built.

The problem of changing the farm from the present condition as

shown in Fig. 1 to a highly organized unit as shown in Fig. 3 will require several years' time. It would not be practicable nor advisable to make the change all in one year. The rapidity with which the changes can be made depends somewhat on the ability of the farmer to drain the low places, break up the new field, and adjust the live stock to the improved conditions.

The plan should first be carefully worked out on paper showing each step in advance until the final, highly developed, properly organized farm is completed.

The final field arrangement depends on the type of farming to be followed as discussed earlier in the chapter. Obviously, if the farm is to be operated as a dairy farm the field arrangement and the number of fields will be somewhat different than if the farm were to be operated as a hog or grain farm.



Central City Market and Wholesale District, Minneapolis.

Courtesy of the Minnesota Experiment Station

CHAPTER III

THE MARKETING OF FARM PRODUCTS

- I. INTEREST IN MARKETING. II. MARKETING A PART OF PRODUCTION. III. COST OF MARKETING—REASONS FOR VARIATION. IV. SPECIALIZATION IN MARKETING. V. ORGANIZATION OF MARKETING—MIDDLEMEN—AT COUNTRY POINTS—NEED OF LOCAL SHIPPERS—WHOLESALE TRADE—BROKERS—AUCTION COMPANIES—RETAIL STORES—CHAIN STORES. VI. METHODS OF SALE—BASIS—KINDS OF SALE—BY CONSIGNMENT—DELIVERED AT DESTINATION—TRACK SALES—CONTRACT SALES. VII. PRICE QUOTATIONS. VIII. DEFECTS IN THE PRESENT SYSTEM OF MARKETING.

Interest in Marketing—Within the past few years there has arisen a great interest in the problem of marketing. Farmers have become dissatisfied with the comparatively low prices received for farm products, and consumers complain of the high prices that they have to pay. This interest has become acute largely because of the great increase in retail prices since 1900. Unfortunately the students of economics and of agriculture in our various universities have heretofore given very little attention to this subject, and there has been very little accurate knowledge available for those who are demanding information on marketing. Consequently there have arisen many fallacious notions about the present system, and

the great majority of the public believe that the organization of distribution is fundamentally wrong.

Marketing a Part of Production — To obtain a sane view of the marketing problem, it is necessary to have some understanding of the place that marketing occupies in the general economic organization of the country. In the first place marketing is a part of production, i. e., it is the process which adds value to the commodities marketed by taking them from places where they are less needed to places where they are more needed, by holding and storing them from one time to another, and by bringing them into the possession of people who wish to consume them. This is a difficult process under present conditions. If there were no large cities, and if people were evenly distributed throughout the producing areas, it would be a comparatively simple matter for farmers to sell directly to consumers in small villages, or at least through country stores, which would be the only middlemen necessary. In reality, we have millions of people congregated in large cities; we have millions of farmers scattered over a large territory, each having a small surplus of produce to market. Furthermore, most farm products are harvested and marketed during a short period of the year, whereas city consumers desire to spread their consumption of these commodities over as long a period as possible. Add to this the fact that many farm products are extremely perishable and the marketing problem appears complex on its face.

COST OF MARKETING

It has been said by many writers that the farmer gets only about thirty-five per cent of the price finally paid for his products; some say forty-six per cent. Either statement is absolutely misleading, not to say incorrect.

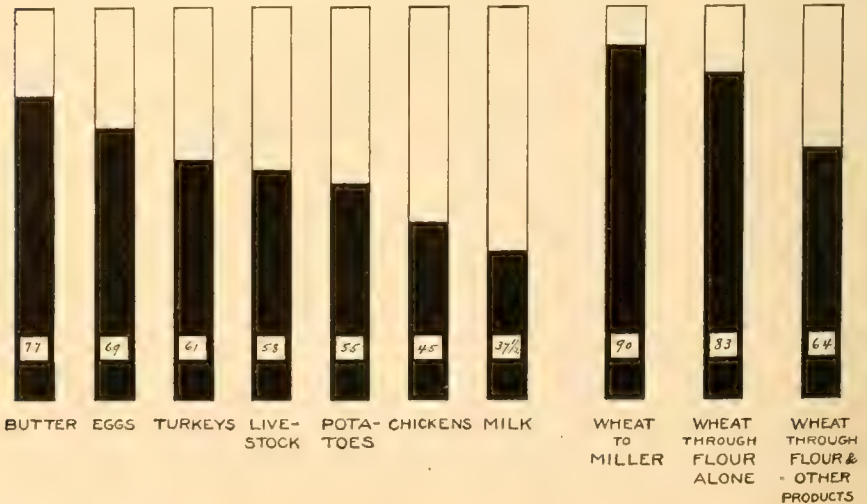

The preceding diagram shows the approximate proportion of Minneapolis retail prices received by Minnesota farmers:

	Per cent of retail price received by producer
Butter	77*
Eggs	69
Turkeys	61
Live Stock	58
Potatoes	55
Chickens	45
Milk	37½
**Wheat—	
To miller	90
Through flour alone	83
Through flour and other products.....	64

*Represents proportion of retail price received by country creamery.

**These figures for wheat were computed from data in Bulletin No. 130 of the United States Bureau of Labor Statistics, "Wheat and Flour Prices from Farmer to Consumer." The data in this bulletin were based on the Kansas City market, but they apply at least approximately to the Minneapolis market.

Reasons for Variation—Although these figures were compiled in Minnesota, they represent very closely the conditions in other parts of the country. At least, they give a good idea of the variation in cost of marketing different commodities, which is the object of their use in this place. If such commodities as apples, asparagus, lettuce, etc., were included, the proportion received by the farmer would be much less. The California cantaloupe grower, for example, receives less than twenty per cent of the price for which his cantaloupes sell in New York City. The principal reasons for this variation in cost of marketing aside from the distance from market are as follows:

1. **Perishability**—The more perishable a commodity is, the greater the cost of marketing. This is the principal reason for the wide spread on such articles as strawberries, cantaloupes, lettuce, etc. In the case of other commodities, such as butter and eggs, perishability is largely overcome by cold storage.

2. **Regularity or Irregularity of Supply Throughout the Year**—The more evenly the production of a commodity is distributed throughout the year, the less it costs to market it. Although butter and eggs are produced in greater volume during some seasons than others the fact that they are produced to a certain extent at all seasons undoubtedly reduces their cost of marketing.

6. **Waste and Shrinkage**—Closely allied to the question of perishability is the extent to which products are subject to damage, breakage, or shrinkage in transit, in storage, or in preparation for market. Breakage is an important factor in egg marketing; shrinkage in poultry marketing.

4. **Volume in Which Product Is Handled**—For those commodities that are handled in greatest volume, the facilities for marketing have become more highly developed. To say nothing of superior transportation facilities, efficient cold storage plants aid in the marketing of poultry and

butter; special loading and unloading machinery and highly efficient terminal elevators in the marketing of grain.

5. **The Extent to Which a Commodity May Be Subdivided Into Well-established Qualities or Grades**—There is a well recognized method of "scoring" butter which facilitates its handling. Grain is subdivided into such universally accepted grades that it is often bought and sold by merely naming the grade or at least by inspection of a small sample. When the buyer must carefully inspect the whole of the commodity he is buying, the cost of marketing is apt to be higher. The possibility of having standard grades enables the use of market quotations, which are often used as "trading bases" and which immensely facilitate the marketing of commodities.

6. **The Relation Between Bulk of a Commodity and Its Intrinsic Value Which Affects the Importance of the Freight Rate as a Factor in Marketing**—Potatoes and grain are of large bulk but of small intrinsic value, and hence the transportation charge constitutes a larger proportion of the total spread between producer and consumer than in the case of butter, which is a commodity of small bulk in relation to its value.

When these differences in cost are considered, it is apparent that some commodities are marketed on very small margins. As compared with manufactured articles in general, the great staple farm products pass through the hands of a greater number of middlemen but are marketed on smaller gross margins. Those who have been fond of calling attention to the wide spread between producer and consumer have dwelt on apples, strawberries, cantaloupes, celery, and other highly seasonal and perishable articles, and have failed to notice that the much more important products like wheat, butter, eggs, etc., are marketed on relatively small margins. If these staple articles were given their due weight in finding an average for all commodities, it would be found that the proportion received by farmers would be considerably higher than any figure heretofore spread broadcast by writers and speakers on this subject. From computations made for Minnesota products, it has been found that on the average the Minnesota farmer receives about sixty per cent of the price finally paid for his products.

SPECIALIZATION IN MARKETING

There is a general feeling that farm products pass through the hands of too many middlemen on their way from producer to consumer. Although this is undoubtedly the case with some products, the fact is generally overlooked that there is a good economic reason for subdivision of the marketing process into a number of separate steps. As already pointed out, marketing is a part of production, just as manufacturing is a part of production. We have come to praise the economies of division of labor or specialization in manufacturing. For example, in the packing plant each workman specializes on some individual task. In the shoe factory the material for a pair of shoes passes through any number of separate hands, each step adding

some increment of value. Again, we praise that kind of specialization whereby one plant operates blast furnaces and makes pig iron; another takes the pig iron and makes crude steel; another takes the crude steel and rolls it out into bars; other plants take the steel bars and make structural forms, machinery, and a thousand other different products.

There is no reason why this same argument of specialization should not apply to the marketing process. There are certain functions that must be performed on the way from farmer to consumer, and each class of dealers specializes on one particular class of functions. Although there is a possibility of carrying this process too far, there are other cases where more middlemen might be added and thereby reduce the cost of marketing. We must remember that middlemen are specialists in marketing, and when we actually study the operations of middlemen, we find that they ordinarily do their work with a high degree of efficiency.

THE ORGANIZATION OF MARKETING

Kinds of Middlemen—In passing from farmer to consumer, commodities generally pass through the hands of local shippers, wholesalers, or commission men, and retail stores. Oftentimes there are two classes of wholesale dealers, such as commission men and jobbers. Sometimes a broker appears between country shipper and wholesale receiver. In other cases auction companies perform part of the service of distribution.

Marketing at Country Points—Local shippers take the form of elevators in the grain trade, creameries in the butter trade, warehouses in the potato trade, cattle buyers and shipping associations in the live-stock trade, cash buyers in the poultry and egg trade, and country stores in the butter and egg trade.

The earliest and crudest form of marketing at country points is through the local stores. Farm-made butter and eggs are still marketed largely in this way. Farmers of the Northwest have much to learn in the marketing of these two commodities. Eggs are not collected often enough, and insufficient care is paid to hens on the farms. The country storekeeper pays the same for all eggs whether good or poor, because he does not dare to offend any of his farmer patrons. He usually pays in trade rather than in cash, which often means that the farmer regulates his purchases by the amount of trade coming to him, rather than by the actual needs of his household. In the southern part of Minnesota, more attention is being paid to the marketing of eggs, and farmers are often paid cash.

Conditions are even worse in the marketing of farm butter. Here again the storekeeper cannot distinguish between different qualities and pays in trade rather than in cash. The store sells the best of this butter to people in the village, and keeps the poorest in a barrel or box until enough has accumulated for shipment to a renovator in some large city. By the time the butter reaches the renovator it is very rancid and dirty. The renovator melts it and blows air through it to drive out some of the evil smell, and reworks

it into "process" or "renovated" butter, which is sold to poor people and cheap restaurants in the large cities.

Need of Local Shippers — It will be generally conceded that some kind of local shipping unit is necessary in nearly all trades. It is necessary for someone to collect and store products until ready for shipment, so that large enough shipments can be made to get carload rates. Sometimes a farmer has enough live stock, potatoes, or grain to ship a carload himself, but more commonly the farmer markets a small quantity at a time. Descriptions of elevators, creameries, and live-stock shipping associations will be found in subsequent chapters.

The Wholesale Trade — When goods reach a large city they pass first into the hands of a commission man or wholesale receiver. It used to be that nearly all farm products were handled on a commission basis, but gradually dealers have come to buy products outright to a much greater extent than formerly. Only in the grain trade and in the live-stock trade are commodities handled principally by commission men.

Wholesale receivers or commission men are dealers who receive goods in large quantities (usually car lots) from the country. These dealers separate the goods into units of convenient sizes, sort them out roughly according to quality, and oftentimes sell them to jobbers who in turn build up a trade with hundreds of retailers, seeing that each retailer gets just the quality, quantity and size that he desires, delivering small lots to retailers from day to day, and assuming the risk of bad debts and slow pay involved in dealing with retailers.

Brokers — Brokers are usually dealers who represent distant shippers. A shipper in northern Minnesota wants to send a carload of potatoes to Kansas City, but he does not know what dealer in that market is in the best position to handle his goods. He therefore turns them over to a broker, who goes around through the market and finds where he can make the best sale for the country shipper. In other words the broker acts as representative for a distant shipper and usually charges a very small amount, such as five dollars or ten dollars per car for his services. It is often well worth while for the country shipper to go to this additional expense, and the broker usually performs an important function.

Auction Companies — It has often been urged that facilities should be provided in our large cities so that all farm products might be sold at auction. As a matter of fact auction companies exist in seventeen of the largest cities of the country, but these companies handle comparatively few products, most of which are fruits. California citrus and deciduous fruits, Florida citrus fruits, fruit from Cuba and Porto Rico, citrus fruits and grapes from foreign countries, including bananas, are practically the only commodities sold at auction. Northwestern boxed apples are sold at auction to only a slight extent. Numerous attempts have been made to sell butter and eggs, and also vegetables at auction, but such attempts have always failed. To make auction sales successful it is necessary to have highly

perishable goods, to have them arrive in large quantities, and to have them absolutely standardized as to quality and package. Otherwise they will be sold at private sale rather than at open auction.

Retail Stores—The last link in the marketing of farm products is the retail store. This is also the most expensive part. Of the total difference between farm price and consumer's price, it has been found that on the average the retailer takes about one-half. In other words, the slice taken by the retail store is on the average about as large as the slice taken by local shippers, transportation companies, wholesalers, and jobbers combined. This does not mean that retail stores are making any larger profits than are wholesalers and other marketing agencies. It merely means that the costs of retailing are extremely high.

On account of the high cost of retailing, there has been a tendency for farmers to buy from catalog houses, and the merchants of many towns are up in arms over the situation. On some articles the catalog house often can and does undersell the local retailer, and whenever the farmer can save money by buying in this way he has a perfect right to do so. On the other hand, there are disadvantages in buying from catalog houses. The farmer can not see the goods that he is buying, and he is often disappointed in them. It often takes a long time to fill an order, and if there is any mistake in the order, it takes a good deal of time to get it straightened out. Furthermore, orders have to be accompanied by cash in advance. Studies made in Minnesota indicate that mail order houses are not offering such severe competition as storekeepers generally think. For instance in one village community, it was found that the mail order business amounted to less than five per cent of the total business of the village.

Chain Stores—In the large eastern cities the high cost of retailing has led to the development of the so-called chain stores, one of the most important recent developments in retail merchandising. A chain store company is one which owns a large number of retail stores in different parts of a city. Such a company usually has a central distribution depot where it concentrates food stuffs in large quantities, similar to a wholesaler or jobber, and delivers to its own stores in different parts of the city. Such stores usually do a spot cash business, and they save by buying goods in large quantities, by standardization of products and methods in the different stores, and by having a competent executive head to the whole system. There is also some saving in advertising and retail deliveries. In Philadelphia there are nine chain store companies with a total of 1,260 grocery stores, and it is claimed that they do over-half of the retail grocery trade in the city.

METHODS OF SALE

Basis of Sale—Sales may be of three different types according to the basis of the sale. These three types are as follows: sale by bulk; sale by sample; sale by description.

By bulk sale is meant a sale which is based on display or inspection of all the goods offered for sale. Sales of live stock are always bulk sales, because the whole animal is inspected by the buyer. Potatoes are commonly sold in bulk, because a buyer is usually afraid to buy by sample. Other commodities are sold very largely by sample, as for instance grain in the Minneapolis Chamber of Commerce. A car lot of grain is sold by the buyers' inspecting a small sample contained in a tin pan about eight inches in diameter and two or three inches deep. Sale by description means making a sale by merely describing the article. The mail order house sells its goods entirely by description in a catalog. Many farm products are sold on the description of the seller, especially when the buyer is a regular customer and knows about what to expect from the seller. In Duluth and Winnipeg wheat is sold largely by simply naming the grade and without even displaying a sample. This also is a good example of sale by description.

As a usual thing the marketing of a commodity is facilitated by the possibility of sale by sample or description. In either of these cases, only goods can be sold that run uniform in quality, and that are honestly packed. Standardization into established grades is one of the great needs in marketing. Many a farmer loses money by exercising no care in sorting his potatoes; eggs are always graded according to color and size by the wholesalers, and the time will come when it will be worth while for the farmers to do this themselves, as indeed they are doing in some parts of the country.

Kinds of Sale—When a farmer sells direct to a country buyer, the sale is usually a cash transaction. In this case both buyer and seller come together, and the operation is comparatively simple. When, however, the farmer, or the country shipper sends goods to a distant market, the situation is very different. The questions as to how the sale shall be made, how settlement shall be made, and how the price shall be determined become very important. In general, there are four different ways for a country shipper to sell to a dealer in a distant market, as follows: consignment, delivered at destination, on track, and by contract.

Sales by Consignment—It has already been stated that sales by consignment have been on the decrease, except in the live stock and grain trades. When a farmer consigns his produce to a commission merchant, he does not know what price he is to receive. The commission merchant does not become the owner of the goods, but merely acts as an agent of the shipper by selling at the highest possible price, from which he deducts a commission, ranging generally from five to ten per cent of the gross returns.

In addition to the fact that the shipper does not know the price he is to receive for his products, a further disadvantage of this method is the fact that commission men have it in their power to misrepresent

the quality of goods, to sell to some allied firm at a low price, or to falsify the returns made to the shipper. Most commission firms are honest, but there are apt to be a few who resort to these practices, and their actions throw discredit on the whole class. On account of the uncertainty of returns, shippers avoid the consignment method as much as possible.

What has been said about uncertainty and the possibility of false returns does not apply so much to the grain and live-stock businesses as to the fruit and vegetable businesses. This is due to the fact that in the principal grain and live-stock markets there are grain exchanges, such as the Minneapolis Chamber of Commerce and the South St. Paul Live-Stock Exchange, to which the commission men belong. One of the principal purposes of these organizations is to establish and enforce rules which govern the transactions of members. The rules governing returns made to shippers, commissions charged, etc., are very strict, and are carefully enforced. For these reasons the shipper is protected against dishonesty, and the only risk that he runs is in a fluctuation of market price between the time of shipment and the date of arrival at market, and, as will be pointed out in the chapter on grain marketing, even this risk can be eliminated by the shipper of grain through the use of the hedging operation.

Owing to the possibility of false returns and other illegitimate practices, Minnesota has a law requiring the licensing and bonding of commission merchants, and giving the Railroad and Warehouse Commission power to examine their books upon complaint from a shipper. New York State has recently passed a similar law, and a great many other states are considering the enactment of similar legislation.

Delivered at Destination—By sale on "delivered" basis, is meant an outright sale to a wholesale dealer, who agrees to take the goods on his own account on the day of arrival and either at a price prevailing on the day of arrival or at some other stipulated price, from which shall be deducted the freight charges from shipping point to destination. In other words, the shipper is not turning the goods over to a commission man who may do whatever he wants with them, but he is selling direct to a dealer who promises to pay full market price on day of arrival. This is a way in which a large proportion of Minnesota butter is marketed in New York and Philadelphia. The wholesale receivers agree to pay a certain price based on the New York butter quotation, as one-half cent under, or one cent over, or the flat quotation. The wholesale receiver knows the quality of butter that a creamery makes when it agrees to pay such a price from week to week. One disadvantage of this method is that even here the wholesale receiver may claim that the quality has fallen off, and he can refuse to pay the stipulated price. The shipper is at the mercy of the receiver in this case, because ordinarily he has no representative in the distant city to

examine the goods and find out if they really have deteriorated in quality. This suggests the need of such a representative, either by means of farmers' organizations, or through a system of government inspectors. The California Fruit Growers' Exchange, for example, has its own representatives in all the principal markets of the country.

There are some cases where wholesalers become the actual purchasers of goods on arrival and yet charge a commission. For example, New York wholesalers in making their returns to Minnesota creameries often report the price as agreed upon and then subtract a commission of five per cent. The object of doing this is to show as high a price paid for the goods as possible, and this accounts for the wide discrepancy in prices claimed by Minnesota buttermakers. For instance one buttermaker claims that he is getting one cent over the New York price delivered at New York, whereas the buttermaker at the next station may be getting the flat New York quotation. It may be that the one who is getting a cent over is having a five per cent commission deducted from the gross price, whereas the other is getting the flat quotation net. Although buttermakers and creamery managers are wise to this practice, the farmer patrons are often fooled, and it would be much better if all creamery patrons should insist that their butter be sold on a net basis rather than with a commission deducted, unless, of course, the butter is really sold on a true commission basis.

"Track Sales"—The principal difference between a track sale and a delivered sale is that in a track sale the price is made f. o. b. shipping point, rather than delivered at destination. The letters f. o. b. stand for "free on board," and mean that the commodities in question are loaded onto the car at shipping point, and that the buyer takes care of them from there on, and pays the freight to destination. Besides knowing actually what price he is receiving, the shipper has the further advantage of being free from loss or trouble due to injury of produce in transit. In other words, if claims arise against the railroad for carelessness in handling, the buyer at the other end assumes the responsibility of collection.

A true on-track sale means one where the price is fixed at time of shipment. This is the case in track sales of grain. Grain dealers send out track bids by mail or by telegraph or telephone, subject to acceptance before a certain time, usually the opening of the market the next morning. If the local shipper accepts such a bid, he knows definitely the price that he is receiving and he bills the grain out at once to the buyer. In some cases, however, track sales are made subject to price on day of arrival. This is frequently done in the butter trade, where the track price merely means a net price, from which no freight or commissions are subtracted.

Contract Sales—By contract sales are meant sales made where the price to be paid is fixed by agreement before the crop is marketed and

sometimes even before it is planted, the farmer agreeing usually to deliver to the buyer all of his crop, or a certain proportion, or a certain fixed amount. Where a contract is made before the crop is planted, such a contract assures a market for the farmer. For example, a canning factory often contracts with the farmers in the neighborhood to buy from them such quantities of peas, beans, or tomatoes, as the farmers may raise on a stipulated number of acres. Beet sugar factories also contract with farmers for a certain number of acres of beets. Often-times factories that contract in this way make advances to farmers to enable them to plant and cultivate the crops properly. Country elevators often contract with farmers for their wheat crops before they are harvested, but as a usual practice this method is hardly to be commended.

PRICE QUOTATIONS

Value of Price Quotations — One interesting and important marketing problem is the meaning, value, and method of determining the market quotations which appear in the daily papers for different commodities. When one follows the cattle market, for example, in the daily papers or farm papers, he reads the quotations, but seldom realizes how such quotations are obtained. Theoretically, at least, price quotations are supposed to report actual prices paid for commodities at a certain time. It is very difficult, however, in the case of some commodities to determine just what actual prices are, and hence the method of determining such prices becomes very important. It is apparent that if the price quotation system were in the hands of unscrupulous dealers, they would have it in their power to manipulate the price from day to day, so that those outside the trade would be misled as to actual market values.

One very important function of market quotations not generally understood, is their use as "trading bases." When a quotation is generally acceptable to the trade, it can be used as the basis for contracts or agreements, as in the case of the methods of fixing the price of butter sent to New York. If the New York quotation were not generally recognized as being correct, it could not be used as the basis for such trade agreements.

Quotations are obtained in various ways, in different trades, and in different markets. In a grain exchange, for example, all of the trades are made in one large room, and it is perfectly apparent to everyone just what prices are being paid. Under such conditions it is very easy to determine the quotations. The quotations of future prices are registered and sent all over the world by a telegraph operator, who sits on an elevated seat beside the trading pit. The closing quotations on cash grain are obtained by a committee which merely goes around the trading floor and finds out what prices are actually being paid.

In the live-stock market it is also comparatively easy to determine correct quotations. The sales are made in one restricted area and there is no secret about the price paid. Generally an independent market reporter, such as the one representing the South St. Paul Reporter, goes through the yards and finds out the price actually paid. And yet there is one question about the cattle quotations at South St. Paul which suggests the importance of the subject of quotations. By studying the South St. Paul Daily Reporter one may find the quotations for cattle, and also a list of the sales actually made, and it will be noticed that generally the highest quotations given for "killing cattle" are higher than any price actually paid during the day. The explanation is that the higher quotations report the price that packers *would be willing to pay* if cattle of good enough quality were received on the market.

In the marketing of butter and eggs, there are produce exchanges in most of the large cities. In Chicago there is the Chicago Butter and Egg Board; in Elgin, the Elgin Butter Board; in New York, the New York Mercantile Exchange. In Chicago and New York the traders come together every forenoon at a fixed hour, and they then proceed to hold a "call." This means that some presiding officer stands before the traders and asks for offerings of butter and eggs. The individual traders, if they have anything to sell, then state the quantity, quality, and price of their offerings. The chairman then calls for bids, and buyers state the price that they are willing to pay for the offerings that have already been made, or for qualities of goods that have not been offered.

Formerly a good deal of butter and eggs was sold under the call in this way in our large cities, but today an extremely small amount is actually sold. In Chicago and New York probably less than one per cent of the butter receipts are sold on the floor of the Exchange. The Elgin Board meets only once a week, and comparatively few tubs of butter are sold at this weekly meeting, and yet the price obtained on the Elgin Board goes out as the quotation of the Board for a whole week. It is apparent that where a very small proportion of a commodity is sold on an open exchange, there is serious question as to whether the prices of these few sales should become the quotations which are spread broadcast throughout the country. In other words, it is comparatively easy for large dealers to manipulate the price by making false bids and offers.

Realizing the shortcomings of the transactions under the call as an accurate index of market values, it came about that the exchanges appointed quotation committees who should decide arbitrarily what the quotations should be, irrespective of the bids and offers under the call. The trouble with this method was that such quotation committees usually fix the quotation so as to suit the purpose of the members of the committee, and as a usual rule they were apt to place the quotations

too low, so that the shippers would not know the true value of their stuff when it reached the principal markets. Practices such as this resulted in legal proceedings against some of our produce exchanges, and they have been prohibited by the courts from issuing quotations except those based on actual sales made on the floor of the exchange. This method is still used in Elgin, but in Chicago and New York the making of quotations is left to outside independent market reporters. In New York City this system has reached perhaps the highest development, where the making of quotations is in the hands of a private firm which has been performing this function in that market for over half a century, and concerning whose ability and impartiality there is not a shadow of suspicion among the members of the trade.

DEFECTS IN THE PRESENT SYSTEM OF MARKETING

Although the general public has a very wrong impression about the general system of marketing, and although it is on the whole much more efficient than is commonly thought, yet there are certain weaknesses or defects that will now be considered. They will be divided into two classes—those connected with marketing at country points, and those connected with the wholesale trade. The principal weaknesses of the system of marketing at country points are as follows:

1. Careless packing and lack of uniformity in packages.
2. Insufficient attention to quality of goods, to sorting before shipment, and to varieties produced.
3. Poor roads from farm to country shipping point.
4. Lack of knowledge of market conditions and prices on the part of farmers.
5. Poor business management on the part of local buyers, country stores, and farmers' organizations.
6. Lack of honesty on the part of both farmers and local buyers.
7. Abuse of monopoly power when there is one buyer, and price agreements when there are several buyers.

Some of the principal weaknesses of the organization and methods of the wholesale produce trade are as follows:

1. Opportunity for fraud and sharp practices. This is due largely to the fact that country shippers are not adequately represented in wholesale markets—a very important phase of the marketing problem.
2. Lack of adequate inspection systems. For some commodities, like grain, there are splendid inspection and grading systems, a function which has been taken over by the government in many states. For other commodities an inspection service is either inadequate or lacking altogether.
3. Wholesale markets are often poorly located, sometimes greatly congested, and often lacking in proper terminal facilities.

4. Lack of an adequate price-quotation system. For some commodities the methods of determining quotations have reached a high degree of development, while for others they are inadequate. Also the quotation system in some cities is more efficient than in others.

5. Lack of sufficient organization and means of obtaining and disseminating market information, resulting in uneven distribution of products among the several markets with consequent gluts and scarcities. This weakness is greatly exaggerated by most writers, because it applies only to the highly perishable and seasonal products. In the grain, live stock, butter, eggs, poultry, and other trades, the balancing of prices between different markets, results in such an even and automatic distribution that the results can only excite our wonder and admiration.

6. Lack of standardization of methods, customs, grades, packages, trade terms, etc., in different markets.

It is only necessary to recite these various shortcomings of our present system to prove that the marketing problem is vastly complex, and that improvement can be brought about only by careful investigation along a number of lines and by the application of one remedy here, and another there. Study of the subject has gone far enough at least to indicate in a general way the nature of some of the remedies. The most important may be classified broadly under four heads: first, co-operation, meaning a type of organization owned and democratically controlled by those who do business through it; second, voluntary associations among dealers; third, government regulation; and fourth, education.

In this country co-operative organizations have developed mainly among producers, and hence have to do principally with marketing at country points. So important is this subject that it will be treated separately in Chapter V.

The part played by associations of dealers in regulating and improving the marketing machinery is not fully appreciated. In many instances such associations have fallen into disrepute because of monopolistic tendencies — sometimes real and sometimes imaginary. It is safe to say, however, that the most highly organized and efficient marketing organizations in the country are to be found among our produce exchanges. The functions performed by such organizations in furnishing market places and trading facilities, adopting rules to prevent fraud, collecting and disseminating market information, and in providing systems of inspection and grading, are invaluable to the economical marketing and even distribution of certain commodities. Such organizations are gradually extending their fields of usefulness, and they must not be underestimated either for what they have done in the past or for what may be accomplished by them in the future.

Many features of the marketing system can be dealt with efficiently only by the government itself. We already have state inspection of grain in many states, and federal inspection, or at least federal supervision, has become a live issue. We have state warehouse laws which govern the operations of grain elevators, and the operations of cold storage plants. Some states have laws which provide for the bonding and licensing of commission merchants, and which compel them to show their books in case of complaint. New York State has recently passed an apple-grading law, and she has also established a Market and Food Department to deal with marketing problems. Minnesota has adopted a state brand for butter, and other states are contemplating a similar move. Several states have passed special laws to make possible the formation of co-operative organizations. Government regulation is an important factor in the solution of the marketing problem.

Finally, these various remedies should be supplemented by education. The principles of marketing should be covered in every course in elementary economics; specialized courses in market distribution should be given in agricultural colleges and schools of commerce; the public should be educated to the fact that they have to pay for the elaborate services that they encourage and demand on the part of retailers; and business men should be educated in matters of efficient merchandising.

In connection with these remedies, public markets and direct marketing by parcel post and express should be mentioned. Public markets where farmers meet consumers have been given relatively more attention than they deserve. They never can play a very important part in the solution of the problem for the following reasons: Only an infinitesimal part of a large city's food supply can be grown within hauling distance; farmers who haul to market can not afford the time necessary to wait around a large part of the day to sell to consumers; a very small proportion of the housewives of a city can leave their children or their household or social duties to go to market; public markets are open only part of each year; and their competition can not reduce prices in retail stores as much as is commonly imagined because people in general are willing to pay for the superior service offered by the stores. Such public markets are good as far as they go and should be encouraged — especially certain modifications of them — but let us not be too optimistic with regard to their possibilities.

A similar idea might be expressed about the possibilities of direct marketing by parcel post or express. The quantity of farm products so marketed is undoubtedly on the increase, but it will always be an extremely small proportion of the total volume. Several reasons might be given why direct marketing is not apt to develop on a large scale. In the bulletin, *Marketing Eggs by Parcel Post*, recently issued by the

United States Department of Agriculture, farmers were told seventeen different things which they must do, ranging from candling their own eggs to assuming losses from breakage, in order to make direct shipment a success. This bulletin, although written in an optimistic vein, furnishes the best of reasons why direct marketing of eggs can not develop on a large scale.



The Grain Elevators of a Minnesota Village.

Courtesy of the Minnesota Experiment Station

CHAPTER IV.

THE MARKETING OF GRAINS

I. MARKETING AT COUNTRY POINTS. II. THE PRICE OF WHEAT. III. MARKETING AT MINNEAPOLIS—FUNCTIONS OF A GRAIN EXCHANGE. IV. FUTURE TRADING—CONTRACT GRADE—SHORT SELLING—HEDGING—PURE SPECULATION—EVILS OF SPECULATION.

At country shipping points, grain ordinarily passes through a local elevator; it is then hauled in carload lots by the railroads to the great primary markets like Minneapolis, Duluth, or Chicago, where it is sold on the grain exchanges. The great bulk of the grain reaching primary markets is bought either by flour mills, or by terminal elevators for storage, or by shippers who buy to send it on to other markets. One interesting feature of grain marketing is "future trading," which takes place in the grain exchanges. Another important feature is the inspection and grading of grain, a function which is taken over in some cases by the states themselves (as for instance in Minnesota and Illinois). Many of the problems connected with the various phases of the grain trade are intricate, and difficult to understand. The most important of them will be described below.

Marketing at Country Points — Although a farmer occasionally loads his own grain direct into a freight car, the usual way is for him to sell to the local elevator. Local elevators are of three kinds, as follows:

1. Line elevators.
2. Independent houses.
3. Co-operative elevators.

When grain first began to be marketed in the Northwest, the country elevators were almost entirely line elevators. That is, they were owned by large companies, with headquarters in the primary markets, each of whom owned a number of houses, usually on certain lines of railroad. Although the line houses furnished a most necessary market for the farmers' grain, their high-handed and often dishonest methods were galling to the farmers. They were too apt to pay less than the wheat was worth; they were often guilty of undergrading or overdocking or underweighing.

As a result, the farmers began building their own houses. This movement began about 1890, but there were many obstacles to be overcome. The railroads were often in league with the line companies and refused to give the farmers trackage, or sell them sites adjacent to the

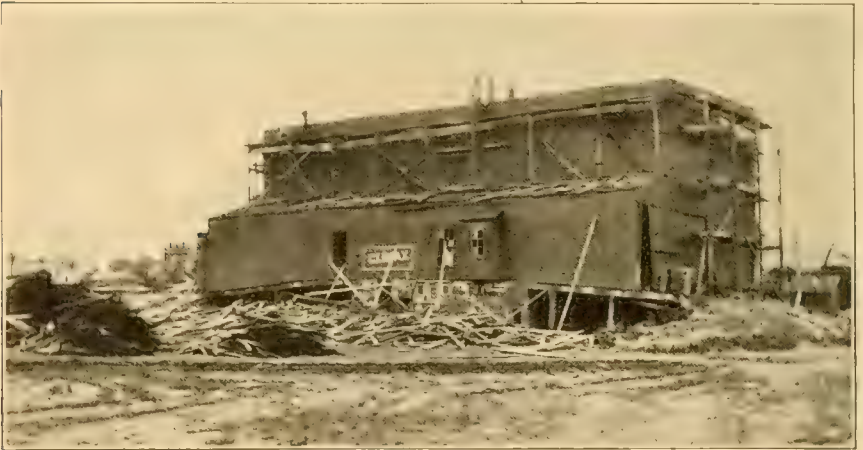

This elevator is being demolished; the lumber goes to Montana to be re-erected as a grain elevator.

Courtesy of the Minnesota Experiment Station

railroads. When a farmers' house began business the line elevators would raise their prices, so that the farmers' houses could not get grain, and they were frequently driven out of business, especially as the farmers themselves had not learned to co-operate, and frequently deserted their own elevators for the sake of getting a cent higher at the line house. After the farmers' house was driven out of business, the line houses of course reduced the prices again, and the farmers were worse off than before.

But since 1900, the farmers' elevator movement has been gaining rapidly on the line elevators. The following figures, issued by the Railroad and Warehouse Commission of Minnesota, show the number of line, independent, and farmers' houses in that state each year from 1909 to 1912:

	1909	1910	1911	1912
Line houses	1,038	994	828	777
Independent houses	283	298	317	300
Farmers' houses	189	213	232	238

It will be seen that line houses have been decreasing in number while farmers' elevators have been increasing. But these figures do not indicate the real importance of the farmers' houses, because they now market about one-third of all grain that is marketed in Minnesota. As a matter of fact there are many more local elevators in Minnesota than are needed. Not so much grain is raised in some parts, and more and more is kept on the farm and fed to cattle and hogs. Many line elevators have been torn down during recent years. The lumber from some of them has been shipped to Montana to be re-erected as grain elevators.

The cost of handling grain in farmers' elevators varies with the amount handled. The following statement shows elevators classed according to the total amount of grain handled, and the average cost of handling per bushel for each class:

Number of bushels handled	Cents per bushel
50,000 to 100,000.....	2.5
100,000 to 150,000.....	1.9
150,000 to 200,000.....	1.5
200,000 to 300,000.....	1.3
300,000 to 400,000.....	1.15

The Price of Wheat—The prices paid for grain at country points are based directly on the prices in the great primary markets. For example, the prices in the Northwest are based mainly on Minneapolis prices. Postal cards are sent out by an organization in Minneapolis to all country points, showing the price to be paid at each point. To determine the price at any single point, the Minneapolis price is taken as the basis; from that is deducted the freight rate per bushel from shipping point to Minneapolis; then one cent (in the case of wheat) is deducted to cover commission for selling in Minneapolis; finally, a margin of two or three cents is subtracted to cover the expense of handling through the local elevators, and to pay incidental charges such as inspection, weighing, and switching. For a point between 200 and 300 miles from Minneapolis, the total of these charges would be 10 or 11 cents, so that the price at such a point would be 10 or 11 cents less than the Minneapolis price.

One may ask, how, in turn, is the Minneapolis price determined? The Minneapolis price likewise depends on the price of wheat in other markets. Wheat flows from regions of surplus production to regions where little wheat is raised, and hence where consumers demand it in large quantities. The wheat world may be likened to a great shallow bowl. In the center, and at the bottom, would be England, Germany, and France, countries which have to import great quantities of wheat.

The principal market in that part of the world is at Liverpool, and hence we may speak of the bottom of the bowl as Liverpool. We can then imagine streams of wheat flowing from the great producing areas, like the American Northwest, Western Canada, Argentina, and Russia, toward the bottom of the bowl. But each stream has certain obstacles or dams over which the wheat must flow in order to reach the bottom. For instance, the wheat flowing from North Dakota, encounters a dam at Duluth, in the shape of flour mills, who take a certain amount of the wheat. But this dam is easily overcome, and the great bulk flows on, only to encounter another dam at Buffalo, where other flour mills partially stop the flow. New York City, or Boston offer some resistance, but still there is a surplus which overflows, and goes to Liverpool.

Now, whether the drawing power of Liverpool is great enough to keep wheat flowing past these obstacles, depends on the price that Liverpool is willing to pay. When American wheat continues to flow over the various dams, it is said to be on an "export basis," and in such a case the price of wheat at Duluth will be the Liverpool price minus the freight and other charges to get the wheat from Duluth to Liverpool. Normally, American wheat is on an export basis, because we produce more than we need. This explains why we say that Liverpool determines or fixes the price of wheat. It must also be obvious that Liverpool is willing to pay only so much as will be necessary to keep the streams flowing, and also that this depends on the world supply of wheat and the intensity of the demand in Liverpool. If the American crop is short, the dam at Minneapolis may arrest the flow, but it can do this only by paying a higher price than the Liverpool price minus the freight and carrying costs. Viewed in this way, it must be clear to anyone that the price of wheat depends primarily on world demand and supply.

MARKETING AT MINNEAPOLIS

Since such a large part of the grain crop of the Northwest is marketed at Minneapolis, and since the Minneapolis Chamber of Commerce is a typical grain exchange, it will be well to use that market as the basis of the following description of terminal marketing. The grain comes to Minneapolis in great quantities—a large number of carloads a day. Samples are taken from each car, one for the State Inspection Department which determines the grade, and the other for use on the floor of the Chamber of Commerce. The sample that goes to the Chamber is put in the hands of the commission man to whom the grain is consigned, the commission man places it on a table on the trading floor of the exchange, and buyers come around and make bids on the various samples. The commission man sells to the highest bidder.

Functions of a Grain Exchange — The principal functions of a grain exchange are as follows:

1. To furnish a convenient market place.
2. To collect and disseminate market information.
3. To establish rules and regulations to govern transactions.

The market place at Minneapolis is in the buildings belonging to the Chamber of Commerce. The greater part of the buildings is taken up by the offices of the various firms, but there is also one large room or hall where the actual trading floor is located. In one half of the room are tables on which the commission men display their samples of grain, and where the actual cash transactions are made. In the other half is located the "pit," where purchases and sales for future delivery are made. At the end of the room is a huge blackboard where quotations from markets all over the world are posted. Ample facilities are also provided for the telegraph companies who receive and transmit market information and quotations as well as the private messages of the members. The grain exchange itself buys and sells no grain. It is merely an association of individual traders, each of whom transacts business on his own account.

In the early days of the grain trade, some of the dealers in all primary markets were guilty of fraudulent practices, and hence the grain exchanges have passed stringent rules to govern the conduct of their members. Members guilty of "uncommercial conduct" are liable to fine or expulsion. The rates of commission are fixed, because otherwise the cut-throat competition of commission men in order to get consignments from country shippers results in many abuses. Systems for arbitration of disputes have been adopted. As a result of these various regulations, it is probably safe to say that marketing in the great organized exchanges is carried out on a higher plane of business morality than in the less thoroughly organized fruit, vegetable, and general produce trades.

FUTURE TRADING

Future trading, or speculation, as it is often called is one of the most difficult phases of the grain trade to understand. In the first place a future trade is nothing but a sale or purchase calling for delivery at some future time. Such a transaction may call for delivery at any time in the future, but it has been found convenient in the grain trade to have definite delivery months, which are September, December, May, and July. When a person sells May wheat, for example, it means that he is contracting to deliver a certain quantity of wheat at such time as he may choose during the month of the following May. The prices of May and July wheat in January, for example, are the prices which represent the combined judgment of a large number of experts as to what wheat will be worth when May and July arrive. Future trading therefore involves the forecasting of future conditions, as based on the

size of the crop and the amount that will be left for consumption when future months arrive.

Contract Grade — When a person buys wheat for future delivery, how does he know what kind or quality of wheat will be delivered to him, since no grade is specified when the deal is made? The rules of the exchange govern this, and in Minneapolis, No. 1 Northern Spring wheat is the "contract grade," i. e., No. 1 Northern must be delivered on contracts for future delivery as they mature, although No. 2 Northern may be delivered at a discount of three and one-half cents per bushel. The latter is rarely done. In Chicago, which is primarily a winter wheat market, No. 2 Hard Winter and No. 2 Red Winter are deliverable on contract.

Short Selling — When a person sells anything that he doesn't own, but which he believes he can buy before he has to make delivery, he "sells short." Thus a man may not own a bushel of wheat, and yet sell 10,000 for May delivery. He knows that before May arrives he can buy 10,000 bushels to fulfill this contract — but he is in hopes that the price will go down some time between the time he sells and the arrival of the following May, so that he can make a profit out of it. If he has to pay more than he has contracted to deliver it for, he will lose money. Consequently, a man that has sold short is in trading terms a "bear," and wants the market to go down. A "bull" on the other hand is a man who has already bought wheat for future delivery, and wants the price to go up so that he can sell out his purchases at a profit. A man may be a bull at some times and a bear at others. There is constant competition between the bulls and the bears, and they are buying and selling all the time during trading hours, so that if anyone wants to buy or sell at any given moment, he will always find someone who will trade with him. This is what is meant by the "continuous market"—an extremely valuable feature of organized grain exchanges. The more buying and selling there is, the "broader" the market; the less the buying and selling, the "narrower" the market.

Hedging — The principal value of future trading is that it offers a market for hedging operations. A dealer hedges the wheat he owns in order to protect himself against future fluctuations in price. A flour miller hedges his flour sales in order to protect himself against a rise in the price of wheat before he gets ready to make the flour he contracts to sell. For example, a flour miller contracts in January to deliver 10,000 barrels of flour in June. How is he to determine the price for which he can sell flour in June? He determines it by looking at the price of wheat for May delivery. When he closes the contract to deliver flour in June, he immediately buys 50,000 bushels of wheat for May delivery. He knows exactly what the wheat costs him, and it makes no difference to him how high the price of wheat may go by the time he gets ready to make the flour. The hedging operation is a protection

—or a kind of insurance. *If the flour miller could not hedge, he would have to sell his flour for a higher price per barrel in order to allow for possible fluctuations in the price of wheat.*

The use made of the future market by the terminal elevators also indicates the great value of the hedging operation. The bulk of the wheat crop is marketed during three or four months in the fall, and it is necessary for the terminal elevator companies to buy this surplus wheat up and hold it for distribution throughout the rest of the year as the flour millers require it. Suppose that we consider the situation of an elevator which has a capacity of 1,000,000 bushels, and let us assume that the price of wheat is about one dollar a bushel. Wheat comes onto the market in great quantities in October, and the elevator is desirous of buying up 1,000,000 bushels of wheat to store, provided it can feel reasonably sure of making a profit by doing so. If there were no future market, this elevator would have to speculate or gamble in the worst possible way. It would have to tie up one million dollars in its elevator, and simply run the risk of either a rise or fall in the price of the wheat. Since money has to be borrowed to finance such a large undertaking, even a slight fall in price would not only wipe out any possible profit, but would probably throw the elevator company into bankruptcy.

But with the system of future trading, the elevator company takes into consideration the future price. Suppose that the elevator company knows that it costs one-half cent per month to carry wheat in its elevator, that is, to pay for interest on capital, insurance, and operating expenses. To carry wheat from October until May (seven months) will cost the elevator three and one-half cents. If the wheat costs \$1.00 in October, and the elevator company can sell it immediately for \$1.05 for delivery in May, the elevator is sure of a profit of one and one-half cents per bushel irrespective of possible fluctuations in the price of wheat. If the May price should be only \$1.02, the terminal company would not buy wheat for storage, because then it would lose money. The terminal elevator companies hedge every bushel of wheat that is taken into their houses, by selling it for future delivery the same day that the actual wheat is bought for storage. If it were not for this possibility of hedging, the terminal elevator would be forced to pay a few cents less per bushel in order to protect itself against possible fluctuations in price. Of course there is a chance that the price of wheat may rise very high, in which case the elevator company would be better off simply to hold the wheat without selling it for future delivery, but there would be so much chance of loss, that the business would be extremely hazardous.

It is also advisable for country elevators to hedge their grain, even though they hold it for just a short time, for by doing this they can protect themselves against loss by possible fluctuation in the price

between the time the grain is bought in the country and the time that it reaches the terminal market. In order to do this, the country elevator sells for future delivery the amount of grain taken into the elevator. When the grain reaches market, it is sold as cash grain, and the future is bought in, thus cancelling the future transaction. If the price of wheat has fallen, the elevator loses on the cash wheat, but gains a similar amount on buying in the hedge, because the future price will have fallen also. This operation can be made clearer by using the following figures, where it is assumed that the price of wheat falls two cents per bushel between the time that it is sold for future delivery, and the time that it reaches market.

BOUGHT		SOLD	
Cash wheat	\$0.90	Future	\$0.95
Future93	Cash wheat88
	\$1.83		\$1.83

From this it will be seen that when the cash wheat was bought at 90 cents, it was immediately sold for future delivery at 95 cents. When it reached market it sold for 88 cents, and the future was bought in for 93 cents. It will be seen that the total amount paid is equal to the total amount received, or that the loss on the cash wheat was balanced by a gain on buying in the future. The elevator of course made its profit by taking out a sufficient margin when it bought the wheat from the farmers in the first place.

Pure Speculation — Not all purchases and sales for future delivery are made for the purpose of hedging. There are those on the market who buy and sell without owning any grain, and without any intention of having it delivered to them. For instance, if a man has bought 50,000 bushels for May delivery, and the price immediately goes up, he may sell it within an hour from the time that he bought it. Or one who has sold short, may "cover," that is, buy in a similar amount, on the same day that he has sold short. The men who do this class of business are the professional speculators. Their presence on the market makes possible the continuous market referred to above, and makes it possible for the man who wants to hedge to find a seller or buyer at any moment during market hours. To prohibit this kind of trading would so narrow the market as at least to injure it, and perhaps to destroy it for hedging transactions. As we have seen, hedging is a most important and necessary factor in the economical marketing of grain.

These speculators are professional risk takers. The handlers of actual wheat shift the risk of price fluctuations onto their shoulders. They also are the ones who forecast future conditions of supply and demand, and who, through expressing their opinions in the forms of bids and offers, cause the prices to be adjusted in such a way as to distribute the crop evenly throughout

the year. By buying and selling in the different markets they keep the prices in these different markets in line with each other, which results in an automatic distribution of the wheat crop among the various markets.

Evils of Speculation — Although speculation plays such an important part in the marketing of the wheat crop, there are certain evils connected with it. The speculators themselves, who are studying the business all the time, are well equipped to speculate, and on the whole they play a very safe game, taking their profits and losses in extremely small doses. They run no more risk in buying and selling wheat than does the farmer in planting a crop of wheat, or than does the merchant in starting a new store, or than does the manufacturer who builds a new plant. There are certain risks in all businesses that people must assume.

The principal trouble with our speculative system is that wheat is very easy to speculate in, that is, it requires so little capital, that outsiders are attracted to satisfy their gambling instinct. Untold misery and harm have resulted from speculation on the part of those who have no right to speculate. The farmer who takes a "flyer" in wheat is guilty of vicious gambling. There is not so much of this gambling by ignorant outsiders today, as there was fifteen years ago, but nevertheless there are some commission men who accept orders to buy and sell from outsiders, and some who even solicit such orders. This is the practice that must be stopped, as well as some minor features of grain exchanges, but these reforms must be brought about in such a way as not to injure the market for hedging transactions.

CHAPTER V

CO-OPERATION

- I. FUNDAMENTALS OF CO-OPERATION—ONE-MAN-ONE-VOTE—LIMITATION OF SHARES—PATRONAGE DIVIDEND. II. CONDITIONS NECESSARY FOR SUCCESSFUL CO-OPERATION—SPECIFIC OBJECT—MANAGEMENT AND ACCOUNTING—SUFFICIENT BUSINESS—SUFFICIENT CAPITAL—LOYALTY. III. CO-OPERATION IN MINNESOTA—SUMMARY—CO-OPERATIVE CREAMERIES—FARMERS' ELEVATORS—CO-OPERATIVE STORES—LIVE-STOCK SHIPPING ASSOCIATIONS—INSURANCE COMPANIES—TELEPHONE COMPANIES—CONCLUSION.

FUNDAMENTAL PRINCIPLES

What Is a Co-operative Organization—A co-operative association differs from an ordinary stock corporation in that the ownership and control lie in the hands of those who do business through the association rather than in the hands of stock owners. The stock of an ordinary corporation is usually owned by a very few people, who manage the business for their own benefit and profit, rather than for the benefit of those who do business through it. As one writer has put it: "The basis of the co-operative organization is men; of the capital stock corporation, money. Capital cannot co-operate; products cannot co-operate; only men can co-operate. When the degree of co-operation of a member is measured by the capital or the volume of business contributed, then the members as men are not co-operating; either capital or a product is the basis of co-operation through the member as a medium."

One-Man-One-Vote—The three fundamentals that are necessary to make an organization co-operative are as follows: the one-man-one-vote principle; the limitation of the number of shares that one person may own; and the patronage dividend. It is desirable to have the par value of stock comparatively small so as to bring it within reach of as many people as possible. Then, according to the one-man-one-vote principle, each member should have but one vote irrespective of the number of shares that he owns. In some cases, members are allowed to vote according to the number of cows, or the amount of grain hauled to the elevator, or some such measure of the member's contribution toward the business of the organization (but not according to capital owned). This method is fair, provided there are not two or three members who do most of the business, but it is simpler and more satisfactory to merely limit the number of votes to one for each member. In fact many of the state laws governing co-operative organizations definitely say that each member shall have but one vote.

Limitation of Shares — To further protect the organization against control by capital, and to make it as purely democratic as possible, it is advisable to limit the number of shares that each member may own. Some organizations limit the number to one share apiece, but in this case it may be difficult to raise enough with which to start business. More commonly the number of shares is limited to four or five or ten apiece. It depends largely on local conditions and on the size of the share where this limit should be put.

The Patronage Dividend — The third principle of co-operation is the patronage dividend. This means that profits should be divided first as a dividend on capital stock not to exceed six or seven per cent, and the surplus to be divided according to the amount of business done by each member with the organization, that is, in proportion to the patronage. This is sometimes called the pro rata division of profits.

It is generally believed by students of co-operation that it is best to include non-members who have patronized the organization, in the division of patronage dividends, although there is some difference of opinion about this and most of the co-operative organizations in the United States divide profits only among members. The argument in favor of including non-members is, first, that the more business that they bring to the organization, the smaller the expense per unit of product, and hence the greater the profit to the members themselves, even though a part of the profits is given to the non-members; and second, that it encourages non-members to buy stock and become full-fledged members of the organization.

It is customary and desirable that when patronage dividends are divided among non-members they should be allowed only half as large a profit per unit of business as is allowed to members. It is also a good plan, when this method is used, not to pay profits to non-members in the form of cash, but merely to credit them with so much paid toward the purchase price of a share of stock so that when a sufficient amount has been accumulated to pay for a share of stock, a stock certificate is issued to the non-member, thus bringing him into the fold.

There is a good deal of misconception and misapprehension about the use of the patronage dividend. In a live-stock shipping association, which requires no capital stock, and which is rarely incorporated, there is no need of a patronage dividend, because the whole returns from each shipment, minus necessary expenses, are divided among the members according to the amount of stock they each shipped. This division is made after each shipment, and no profits are accumulated which need to be divided at the end of the year. Much the same situation obtains in the case of co-operative creameries where members are paid for their butter fat each month by distributing the gross returns of the previous month minus the necessary expenses of that month. In such a case a creamery can be absolutely co-operative, even though the by-laws do not provide for the patronage dividend. If enough is taken out each month to merely pay interest of

five or six per cent on capital stock, that is all that is necessary. If, however, the profits are allowed to accumulate so that the association could pay more than six or seven per cent, then it is necessary to have the patronage dividend, so that members will not be trying to get high dividends, and so that each patron will be recompensed in proportion to the amount of butter fat that he brings in. To provide against such a contingency, it is better to always provide for the patronage dividend in the by-laws, even though the original intention is to run on a no-profit basis.

CONDITIONS NECESSARY FOR SUCCESSFUL CO-OPERATION

It is not so easy to co-operate successfully as one might think. The great number of failures that there have been are ample testimony that it is difficult to develop successful co-operation. Some of the essential conditions that are necessary to make a co-operative organization successful are discussed in the following paragraphs.

It is generally considered that first of all there must be some real need for the organization proposed. In other words there must be some conditions such as lack of marketing facilities, or dishonesty of local buyers, or monopoly on part of local buyers, or some other vital reason, why a co-operative organization is absolutely needed. This thought is expressed very forcibly by G. Harold Powell in his bulletin "Fundamental Principles of Co-operation in Agriculture," California Circular No. 123, as follows:

"A co-operative organization of farmers must be founded on economic necessity if it is to be permanently successful. The reason for its existence must lie in some vital service which it is expected to perform, if it is to have strength enough to live in the face of the competition to which it will be instantly subjected. It must compete with existing organizations and this competition will be directed towards eliminating it; it will be viciously attacked; every conceivable form of misrepresentation will be leveled against it; the officers will be attacked by insidious rumors concerning their ability or integrity, the banks, especially in the newer sections, may be controlled by competitors, and may refuse to furnish the necessary credit; and every weapon known to competition, either legitimate or disreputable, will be used to put it out of business.

The average producer is not a business man, nor is he skilled in the arts of competitive business. He is naturally a strong individualist. He is slow to delegate authority over his affairs to any one and when he is face to face with the skilful arguments of those who aim to break the organization and keep him working as an individual, he is likely to weaken and finally leave the organization unless he had felt the effect of hard times, a helplessness arising from a combination of those who buy or sell his products, excessive freight, or commission charges, or other forms of oppression. It

is an historical fact that the investment of the farmer must have been threatened by existing conditions before he has been able, in the past, to overcome his individualism sufficiently to work with his neighbors in co-operative work. The country is strewn with the wrecks of co-operative organizations that were born prematurely and which died by the wayside, because the farmer himself deserted in the first real conflict with the established agencies that have handled his business. Co-operation, to be successful, must be founded not only on economic necessity, but it must grow through gradual evolution. It must have a small beginning and grow in strength through experience, step by step, rather than by leaps and bounds. The fundamental mistake that is being made in many localities is to form a farmers' organization all at once on the plan of an organization that has taken years to develop. The plan may be sound but a co-operative organization can only succeed when given the unflinching support of the members who through years of experience have acquired an appreciation of the fundamentals that underlie a successful association of this kind. The success of any organization depends on its members, not on its form."

Must Have Specific Object — Another requirement is that a co-operative association should be organized for the purpose of handling some special crop or commodity, rather than for handling all commodities that the farmers have to sell. This is the reason why a single community often has a number of separate organizations, such as a creamery, an elevator, a stock-shipping association, etc. Sometimes a creamery handles eggs, but if there are enough eggs to make it worth while, it would be better to have a separate egg-shipping association. Sometimes when the manager of an organization has spare time on his hands, it is all right to let him handle some side-line. Farmers' elevators seem to be especially well suited for handling other commodities, especially in the purchase of supplies. It is better for an elevator not to try to market other commodities for farmers, although sometimes they handle live stock. As a general rule it is better not to try to handle too many commodities.

It is also a good plan not to try to have an organization cover too much territory. That is, it should comprise only the farmers living in a given locality, so that they can all get together frequently and know each other personally. There are, of course, some large co-operative organizations, but these are usually federations of small local units. Federations of this sort are highly desirable, and must be developed in the United States, but co-operation must begin with small local organizations as described above.

Management and Accounting — One of the most important requisites of co-operation is that it shall be managed by a competent man. Associations too frequently hire some retired farmer, or the son of one of the board of directors, or some other individual who has had no experience in marketing the commodity handled by the association. Farmers are also loath to pay a high enough salary to get an experienced, capable man. Figures compiled in Minnesota show that the managers of the successful farmers'

elevators are paid an average of ten dollars a month more than the managers of the elevators that lost money. The writer recently visited an elevator in the southern part of Minnesota which has lost \$5,000 in one season. Upon looking into the affairs of the company it was found that it had handled over \$200,000 worth of business under a manager who was a retired farmer with no experience either in selling grain or bookkeeping, and who was being paid fifty dollars a month! This company would have found it cheaper to pay ninety dollars or one hundred dollars a month for an experienced manager.

The lack of well-kept accounts is one of the principal weaknesses in the co-operative movement. There are some private companies that make a business of installing accounting systems for different kinds of farmers' organizations, and it is better to hire such companies to install a system unless the manager has had adequate experience elsewhere to develop his own system. The most encouraging thing along this line is the work started by the Office of Markets of the United States Department of Agriculture. This office has a division which is studying the systems of accounts used by farmers' organizations throughout the country and constructing systems for use by each kind of organization.

"Co-operative Organization Business Methods," Bulletin No. 178, U. S. Department of Agriculture, issued by the Office of Markets has this to say on the importance of a good accounting system:

"Accurate records and accounts are essential in the management of every business enterprise, great or small. The failure of many co-operative organizations for marketing farm products has been traced either directly or indirectly to the lack of proper accounting systems.

"The very life of a co-operative organization depends on the confidence reposed in it by the members and on their knowledge that the affairs of the organizations are conducted in a businesslike manner and that each transaction is recorded clearly and accurately in books of account. Such records will tend greatly to increase confidence. The organizations which keep accurate records will also be in a better position to command the necessary financial assistance from bankers and credit men, when such help is needed, than the associations having lax systems of accounting records."

Not only is a good accounting system necessary, but the organization must provide for both internal and external audits. The internal audit can be made by a committee of the board of directors, and this is the only kind of audit that most organizations provide for. Such an internal audit is good as far as it goes, but it is incomplete and usually made by members who are not experts in accounting. Consequently an internal audit is not a sufficient protection against fraud on the part of the manager, nor does it furnish a sufficiently accurate analysis of accounts. For this reason, every co-operative association should call in a public accountant to make a thorough audit of the books at least once a year before the annual meeting.

Must Have Sufficient Business—Oftentimes farmers make the

mistake of forming an organization when they haven't enough business to make it worth while. This has been true of a great many creameries, which have oftentimes been started as the result of an agitation by a professional promoter. Although such promoters are not so common now as they were twenty years ago, nevertheless they are still active in some parts of the country. Some promoters make their money by selling a plant or equipment at an advanced price to the new organization, while others make theirs by charging organization fees. Some of the latter are perfectly legitimate, but it is well for farmers to look up the record of anyone who comes into the community and tries to get the farmers to organize.

Must Have Sufficient Capital—Another mistake that farmers' organizations often make is to start in business with too little paid-in capital. This results in starting out with a large debt, a fact which keeps other farmers from joining, and which makes it hard for the organization to get on its feet. For some kinds of co-operative organizations, farmers must be careful about the time of year that the organization is started. For instance in the case of a farmer's elevator, it is well to start it in the winter so that there will be time to get enough capital subscribed and enough money paid in to allow ample time to buy or build an elevator in time for the harvesting season next fall. If not enough time is allowed, there is too much of a temptation to rush the thing through and to start in business without enough money paid in.

Loyalty—Above all things there must be a spirit of loyalty, or there must be what is often called the "spirit of co-operation" among the farmers of any community that forms an organization. Farmers who are so independent as to insist on the carrying out of their own ideas, and who will not graciously submit to the will of the majority, are undesirable members. When a member sells to an independent company because he can get a slightly higher price, he is not only doing his neighbors a great injustice, but he is cutting his own throat. It is hard to understand how a farmer can frequently be so short-sighted and so disloyal as to deliberately kill off his own organization by selling his products to a competitor for a few paltry cents more than he can get from his own association. In the long run, he, and the rest of the community, will suffer, because just as soon as his own association is killed, the outside buyers immediately lower their prices.

CO-OPERATION IN MINNESOTA

Summary—Since Minnesota leads all other states of the Union in number of co-operative organizations and in volume of business transacted co-operatively, a detailed discussion of co-operative organizations in that state serves the purpose of informing the reader about the various kinds of activity. The following statement shows the number of co-operative organizations of each kind in Minnesota on Jan. 1, 1914, and the volume of business transacted by them in 1913:

Number and Summary of the Annual Business of Co-Operative Organizations in Minnesota (Partly Estimated)

	Number	Annual Volume of Business
Creameries	614	\$21,675,252
Elevators	270	24,000,000
Stock-shipping associations	115	6,000,000
Stores	120	4,250,000
Fire insurance companies	154	696,732
Telephone companies	600	900,000
Cheese factories	34	637,224
Potato warehouses	20	100,000
Miscellaneous	86	2,500,000
Total	2,013	\$60,760,000

Among miscellaneous organizations are cow-testing associations, 11; fruit shipping associations, 3; lumber yards, 5; laundry, 1; egg-shipping associations, 2; cattle and horse-breeding associations, 60; wool-growers' warehouse, 1; terminal grain-marketing company, 1; butter-marketing association, 1; and terminal fruit and produce-marketing association, 1. More than four-fifths of the volume of business of these miscellaneous companies was transacted by the terminal grain-marketing company and the butter-marketing association.

Co-operative Creameries — The co-operative creameries are perhaps the most important farmers' organizations in Minnesota. There are 614 in all and this is nearly twice as many co-operative creameries as may be found in any other state in the country, and nearly one-third of all in the United States. Not only this, but nearly three-fourths of all the creameries of Minnesota are owned co-operatively by the farmers themselves, and 42 per cent of all farmers in the state are patrons of co-operative creameries. There is no important dairy state in the Union where the butter industry is so completely controlled by the farmers themselves.

In 1913 these 614 creameries made 71,931,910 pounds of butter, which if made into ordinary pound prints and placed end to end would reach over 5,000 miles. The patrons of these creameries received about \$20,000,000 for butter fat during 1913, or an average of over \$32,000 per creamery. The average number of pounds of butter made per creamery was 122,000 pounds. The average expense per pound of butter was 2.2 cents, the total number of patrons was 65,000, and the average number of patrons per creamery was 106.

Practically all of these creameries have the one-man-one-vote principle, and 65 per cent limit the number of shares that each member may own. One share apiece is the commonest limit, but many limit to two, four, five, and ten shares apiece. One of the most interesting features of these Minnesota creameries is the fact that there are a number which were never incorporated, and which started in business years ago by borrowing enough money to build the creamery on the joint note of several farmers. The loans have been paid back gradually by setting aside a small amount from each pound of butter sold. As the debts were extinguished and the notes cancelled, these creameries

have been left with apparently no legal owners and they continue to exist and do business in that condition. The farmers take pride in feeling that such creameries really belong to the community at large, and no finer example of true and loyal co-operation can be found in any country.

Only 20 per cent of the co-operative creameries of Minnesota make provision in their by-laws for the distribution of profits on a patronage basis. This, however, is not a serious matter, and does not indicate any failure to comply with co-operative principles, as pointed out above because a majority of creameries are operated on a no-profit basis, deducting from their gross receipts enough to cover expenses, and distributing the remainder from month to month according to the amount of butter fat brought by each patron. This is exactly equivalent to the patronage dividend, and is even better. In many of the older creameries, not even dividends on capital stock are paid.

Out of 229 creameries that reported how often patrons are paid for butter fat, 79.9 per cent (or practically four-fifths) pay monthly; 15.3 per cent semi-monthly, 1.3 per cent weekly, and 3.5 per cent daily. To pay patrons monthly is generally accepted as the best plan. The price paid for butter fat is then found by distributing the receipts of the previous month (minus expenses) over the total number of pounds of butter fat brought to the creamery. This method also involves the least amount of bookkeeping. When farmers are paid weekly or daily, it is more difficult to determine a fair price to be paid for butter fat, and it is difficult or even impossible to run safely on a no-profit basis. Under such conditions the patronage dividend is necessary in order to make the organization truly co-operative. The usual reason for paying patrons weekly or daily is that the competition of centralizers who pay cash for cream may be met. For a co-operative creamery to have to pay cash to farmers in order to keep them from shipping to centralizers, is an indication that the patrons are not over-loyal to their organization. The subject of the co-operative creamery is treated more fully in Chapter VI of this book.

Farmers' Elevators — On January 1, 1914, there were practically 270 farmers' elevators in Minnesota with an aggregate membership of approximately 34,500, an average of 128 members to a company. One farmer out of every five in the state is a member of a farmers' elevator company. The aggregate volume of business of these companies for the year following the harvesting of the 1912 crop was about \$24,000,000, of which about \$22,000,000 represents the value of grain marketed, and the other \$2,000,000 the value of supplies, such as coal, feed, twine, etc., purchased for members.

Many so-called "farmers' elevators" in Minnesota are not owned by farmers and should not be classed as co-operative companies. Even among the 270 elevators classified herein as co-operative, there are many which certain co-operation enthusiasts would undoubtedly exclude. But in all of the 270 elevator companies farmers own the majority of stock, and in all but 5.5 per cent of them each stockholder has but one vote irrespective of the

number of shares owned. Furthermore, in five-sixths of the companies the number of shares that may be owned by one person is limited. In other words, the elevators are not only owned by the farmers themselves, but they are controlled democratically by them.

As for the patronage dividend, it is in this particular that some of the farmers' elevators of Minnesota fall short of fulfilling complete requirements of co-operation. Only 26 per cent of the companies in the state distribute profits in this way. And yet there is danger of putting too much importance on the patronage dividend with regard to these farmers' elevators. Out of 139 companies from which complete information was obtained, there were 59, or 42.4 per cent of the total that paid no dividends at all; there were only 18 that paid over 10 per cent. One of these paid 125 per cent, but has since changed to the patronage dividend. Ten per cent was the commonest rate of dividends for these elevators to pay, and since many of them are situated in those parts of the state where interest rates are high, and since there is more or less risk in farmers' elevators anyway, there is some justification for allowing a stock dividend of 10 per cent. In fact, of those companies that have the patronage dividend a large number pay stock dividends of 10 per cent before distributing anything on a patronage basis. In other words, since the number of elevators that pay over a fair rate of interest is so small, and since they are owned and operated by the farmers themselves, there seems to be justification for including them all among co-operative companies.

The co-operative purchase of supplies through farmers' elevators is an important feature. Out of 239 companies reporting, there are only 41 that do nothing but market grain. Of the total, 63 per cent handle coal; 40 per cent, flour; 41 per cent, feed; 35 per cent, binding twine; 18 per cent, seeds; 16 per cent, salt; 7 per cent, tile; and 7 per cent, farm machinery. There are also a few that handle lumber, fence posts, wire fencing and cement.

Co-operative Stores—The aggregate sales of the 125 co-operative stores in Minnesota were approximately \$4,250,000 in 1913. The smallest business reported by a single store was \$5,312, and the largest \$161,850.

The history of the co-operative-store movement from the earliest days is not particularly encouraging, because undoubtedly more attempts have failed than have succeeded; but there are no figures to prove that the experience of co-operative stores has been much, if any, worse than that of privately owned stores. There are sufficient indications that within the last few years the co-operative-store movement has been proceeding on a more substantial and business-like basis. There are many stores that are in a very prosperous condition, and there are many that have been in business for a long time, although the following figures show that the great majority of those now in business have been organized within the last six or seven years.

Year of Organization of 62 Co-operative Stores.

Year of Organization	Number of Stores
1893.....	1
1894.....	1
1899.....	1
1900.....	1
1903.....	1
1901.....	1
1905.....	2
1906.....	3
1907.....	2
1908.....	6
1909.....	5
1910.....	8
1911.....	14
1912.....	9
1913.....	7

Fifty-nine stores reported a total of 6,160 stockholders, an average of 104 per company. Taking this as an average for the 120 stores, there are in the neighborhood of 12,000 people who are members of co-operative-store companies in Minnesota. Farmers own 86 per cent of the stock and this is one of the significant features of the co-operative stores of the state; they are not found in the large cities, but located in the villages and at country crossroads, and are owned and operated by farmers. All have the one-man-one-vote principle, and out of 53 stores, all but 7 limit the number of shares that the one person may own. Nearly half of these limit to 10 shares apiece, while some limit to 5 apiece.

Although the co-operative stores uniformly provide for patronage or trade dividends, there are many which have not had sufficient profits to pay any. In fact, out of 57 stores reporting, there were 18 that paid no dividends, even on stock. The average rate of stock dividend paid by the other 39 was 6.19 per cent. Twenty-eight paid trade dividends, an average rate of 5.6 per cent to members, and 3.5 per cent to non-members. The practice as to the payment of trade dividends to non-members varies. Out of 23 stores which reported on this point, there were 6 that paid the same rate to both members and non-members; 10 that paid members at twice as high a rate as non-members; and 7 that paid trade dividends to members only.

The average sales of 61 stores for 1913 were \$42,500, and the inventory value on January 1, 1914, was \$13,200, indicating a turn-over of little more than three times. The proportion of expenses to sales was only 10.9 per cent, which is lower than for ordinary privately-owned stores. Thirty-one per cent of total sales were credit sales; 59 per cent of sales were made to members, and balance to non-members.

Live-Stock Shipping Associations—The form of co-operation that is gaining most rapidly at present is the live-stock shipping association, and in this respect Minnesota far outstrips any other state in the Union. The movement began in 1908, and has been spreading very

rapidly, especially since 1911. On January 1, 1914, there were 135 shipping associations in the state. On January 1, 1915, there were nearly 150. During 1913 these associations marketed about \$6,000,000 worth of stock, or about 12 per cent of the total value of live stock marketed by Minnesota farmers.

The live-stock shipping association supplants the local cattle buyer through whom live stock is bought at the country points. Such a local buyer has the expense of traveling around the country to the various farms, and also has to make enough to pay for his own time. Through the co-operative method, the manager is appointed, and paid usually 6 cents per 100 pounds for shipping the stock. The farmers telephone to the manager when their stock is ready, and the expense of a local cattle buyer is saved, especially as the manager usually handles the farmers' stock as a sideline. In this way the farmer gets from 25 to 50 cents, or even more, per 100 pounds for his stock.

Live-stock shipping associations are easy to organize because no capital stock is required and it is not necessary to incorporate. A formal association must be organized, articles of association adopted and officers elected. After a competent and reliable manager is hired, the business is easy to handle. These associations are particularly well adapted to those parts of the Northwest where farmers want to sell less than a carload of stock at a time. In fact, in Iowa, where there are many carlot shippers, these associations have not developed to any great extent.

Insurance Companies—An account of co-operation in Minnesota would be incomplete without a reference to "township mutual insurance companies," of which there are 154 in Minnesota. This is the earliest form of permanently successful co-operation that developed in that state. It is said that the first two companies started as early as 1867, and that of all the companies that have been started, not one has ever failed. The total amount of insurance in force on January 1, 1914, was \$342,000,000, which was nearly twice as much as was in force eight years earlier.

The cost of insurance in these companies has been very low; in 1913 it was 18 cents per \$100. The rate of stock companies which still solicit this business is 46 cents per \$100 per year on three-year contracts. On the \$342,000,000 of insurance carried by the township mutuals, these companies saved the farmers of the state \$957,600 in the year 1913. The actual saving is much greater than this because the rates charged by the old-line companies have been forced down by the competition of the farmers' companies. It has been estimated that the total saving for 35 years up to 1910, allowing for the effect of competition in reducing the rates of old-line companies, and for compound interest on the premium charges saved from year to year, would probably be about \$20,000,000.

The number of policies in force on January 1, 1914, was 158,283, or about 2,000 more than the number of farms in the state. This is accounted for by the fact that personal property and buildings are commonly insured on separate policies. It is a conservative estimate, however, that 75 or 80 per cent of all farmers in Minnesota are insured in these co-operative companies.

Co-operative Telephone Companies—Co-operative telephone companies have also been increasing in number very rapidly during the past few years. In the whole state of Minnesota there were 148 telephone companies of all kinds in 1905; in 1913 there were 873. About 600 of these were owned and operated by the farmers themselves, and these rural lines have played an extremely important part in improving both the social and economic well-being of the farmers.

Less than half of these co-operative companies are incorporated. The average number of stockholders per company is 72, the average number of subscribers 76, and the average number of miles of line per company, 72. In other words, there is approximately one subscriber for each mile of line. On the whole these companies are not run for profit, and the average cost of telephone service per year is a little less than \$6, although the subscriber usually has to buy his own instrument and make his own connection with the main line.

Conclusion—It will be seen from the foregoing description of co-operation in Minnesota, that this much desired form of organization among farmers has reached a fairly high state of development. When it is considered that the rural population is sparse on account of the large size of farms, and when it is realized that the country is comparatively new and that it is settled by a great mixture of nationalities, it is surprising that co-operation has made the headway that it has. In fact the desire to organize is so strong in some localities that the movement needs supervision and direction more than encouragement. The various state universities are studying this subject, and most of them are already prepared to assist farmers in organizing and to instruct them how they should carry on business.

CHAPTER VI

CO-OPERATIVE CREAMERIES AND CHEESE FACTORIES

INTRODUCTION. I. THE FIRST MEETING—QUESTIONS TO BE DISCUSSED—ORGANIZATION AGREEMENT. II. GETTING SUBSCRIBERS. III. SECOND MEETING. IV. THE BUILDING. V. HIRING THE BUTTER OR CHEESE MAKER. VI. THINGS WORTH REMEMBERING. VII. ARTICLES OF INCORPORATION—BY-LAWS.

Introduction—Wherever co-operative creameries and cheese factories have been established a great increase both in quality and in quantity of the butter and cheese produced has been noted. In ten years Minnesota increased its dairy industry one-half and although part of this gain must be laid to the favorable natural conditions of that state, yet much assistance was rendered by the proper organization of the co-operative factories. Under proper conditions no industry will pay better than dairying, and co-operation assures the return of the profits straight to the farmers' pockets. Although the co-operative creamery is not a new thing and much has been said regarding its organization, yet it is a matter that cannot be taken up without exact information, and the following chapter, which is the result of years of work and experience will prove valuable to those desirous of building up the dairy industry in their community.

THE FIRST MEETING

It is desirable to have present at the first meeting some one who is in every way familiar with similar organizations and who fully understands what is needed to make a creamery or cheese factory successful from the start. A man to give such assistance can usually be had by applying to the dairy division of your university farm. The assistance of one in the state service gives the benefit of a disinterested man of experience. It is not necessary to go to the creamery promoter for advice in establishing a co-operative creamery.

If possible, it is also desirable to have present an officer of some successful creamery or cheese factory, as such a man can assist materially in answering numerous questions that are asked by those interested in the proposed organization.

It is not often that a sufficient number can be induced to come to the first meeting, so that a permanent organization can be perfected at once. There are always a number who prefer to wait and see whether the movement seems likely to succeed before they take an active part

in the work. This should not discourage those who do the preliminary work, as it is a matter of education, and some one must lead. Even if the first meeting in a community is not very well attended, it does not always follow that an organization should not be started. If you have the proper conditions it is possible to get those who hesitate at first to see that it is to their interest to join in the movement. It should be remembered that the men are needed in the organization as much as they need the organization. The work of arousing interest and selling shares is often left until after the factory is started, but such a course is likely to endanger the success of the undertaking.

Good Chairman Needed — The chairman of the meeting should be a man of some executive ability, as he must see that all questions are given due consideration. He must also make an effort to avoid unnecessary discussions and have all questions acted upon promptly, as any delay in the progress of organization may make it more difficult to complete. Much depends upon the chairman of the meeting.

Location — The most convenient location for the creamery or cheese factory should be decided upon, so that this information can be given to prospective buyers of shares. The points to consider are accessibility to patrons, good drainage facilities, and shipping advantages.

Amount of Raw Material Necessary — One of the vital questions to be discussed at the first meeting is whether there is enough milk within reach to make possible the economical operation of a factory. No creamery or cheese factory can be run without milk or cream, no matter how well organized or how skilfully managed. If, after discussing the matter fully, it is decided to see what can be done, an organization agreement should be drawn up and a committee chosen to see how many cows can be found in the territory. Those who are willing to join can sign an organization agreement before the meeting is adjourned, thus saving work for the canvassing committee.

Organization Agreement — The following preliminary or organization agreement signed after the amount of milk or cream needed and the size of the shares are determined, will protect the first signers:

“We, the undersigned citizens of County, State of, do hereby agree to form an association for the purpose of manufacturing and to take the number of shares of stock, at a rate of dollars each, and to furnish the milk or cream from the number of cows, set opposite our names. Provided, however, that if milk or cream from cows be not pledged and dollars subscribed on or before, 19... , this agreement shall be null and void.

Names	Shares	Cows
.....
.....

Number of Cows — The number of cows which should be required to make the agreement binding will depend somewhat on local conditions. In sections where grain raising is largely carried on, a greater number of cows will be required than where there is every indication of diversified farming and where everything points towards development along dairy lines. At least four hundred cows are required for starting a creamery, though it is much safer to have at least five hundred or six hundred; a cheese factory may be started with from one to two hundred.

Form of Organization — We believe the most businesslike way of organizing is to form a co-operative corporation at once in accordance with the laws of the state, as outlined at the close of this chapter. Full particulars will be furnished in most cases on application to your state dairy and food department. By incorporation the absolute legal status of the organization is established.



Albert Lea State Creamery.

Courtesy of the Minnesota Experiment Station

True Co-operation — We believe such an organization will be most successful if started along the line of true co-operation, the three important principles of which are: (1) one vote for each share-holder, regardless of the number of shares; (2) only a fair rate of interest paid on capital stock, and (3) dividends, if any, paid on the basis of patronage, that is, pro rata on the amount of cream or milk delivered for manufacture.

Size of Shares — The size of shares will depend much on local conditions. They vary from \$10 to \$50 each. In a locality where there are many renters or small farms it is best not to make the shares too large, as it may keep many from becoming shareholders. The number of shareholders is of much greater importance than the amount of money pledged, and the shares should be of such size that few, if any, will be barred from joining.

Lack of funds should not bar a man from becoming a shareholder, because a promissory note can be issued and is usually as good as cash. This note should bear the usual rate of interest and can be paid at a time convenient to the one giving it; or, if preferred, a stipulated sum or percentage of the value of the milk or cream brought to the factory by any patron may be applied on his share. In this way a share will eventually be delivered to the patron without any hardship to him.

Getting Subscribers—The time required to canvass the territory will depend upon how much interest is displayed and how many are willing to work to secure signers. The sooner this is finished, the better. A great deal of preliminary work must be done by some one, and it generally falls upon a few, whose only compensation is the thought that they are working in a good cause. This may not look like strict co-operation, but we must at least admit that those who spend time and energy to promote a co-operative organization are good co-operators, and are usually doing much to build up the dairy industry.

Committee on Subscriptions—Several committees, of one or two members each, should then be selected to visit the farmers in the community and solicit shares and ascertain the number of cows. These committees should be selected with a view to covering the territory as conveniently as possible. Four committees chosen from different parts of the territory should be sufficient under most conditions.

It is important that the necessary signers be secured before the date set for the second meeting, as a man who has signed his name to the agreement will be more likely to take an active interest in getting the organization under way than one who has made no promises.

Committee on By-Laws—A copy of Articles of Incorporation is submitted below. Similar copies can probably be obtained from the state dairy and food department, located at the state capitol, together with a set of by-laws, which will serve as a guide, and may be changed to suit local conditions. It will facilitate matters and save time if a committee is appointed at the first meeting to work out a set of by-laws to be presented later.

SECOND MEETING

At the second meeting a temporary president and secretary should again be chosen unless it is agreed to let the chairman and secretary of the former meeting continue to serve.

It is advisable to have the minutes of the first meeting read and approved in order that every one present may know what has been done. To insure success, everything must be open and above board, as this helps to avoid the jealousy and suspicion so unpleasant in co-operative organizations.

Reports of Committees—When the reports of the canvassing committees indicate that the required cows and capital have been pledged,

the organization may be made permanent by adopting articles of incorporation and electing permanent officers. The officers usually elected are president, vice-president, secretary, treasurer, and three directors.

Care should be exercised to elect the best available men, as the success of the organization depends largely upon them. In most cases the secretary acts also as manager, and it is desirable that the man selected for this office shall have had some previous experience in business and be qualified to keep accurate accounts. He should be agreeable and tactful, and one in whom the people have confidence.

If possible, it is best to select the officers from different parts of the community, as in that way the patrons will all feel that they have representatives on the board.

Salaries of Officers — The salaries the officers should receive depend largely on how much business is transacted. It is usual to pay the secretary and manager a small salary, varying from \$10 to \$25 per month. In the case of a new factory, it is advisable to pay him a moderate salary until it is known how extensive a business will be done and how much of his time will be required. The treasurer should be paid for the time he spends in the interest of the association. The directors are usually paid from \$1 to \$2 each for each board meeting they attend.

Name — The name of the association must be inserted in the articles of incorporation. Select a short one that you think is appropriate for your community. It is fitting that the word "Co-operative" should appear somewhere in the name.

Capital Stock — The amount of capital stock for a co-operative organization is limited by law to \$25,000. The amount of capital needed will depend on how much is necessary to erect and equip the building and carry on the business. The amount of capital stock needed varies from \$1,000 to \$10,000 for a creamery, and from \$3,000 to \$6,000 for a cheese factory. It is permissible and oftentimes expedient to capitalize for a larger amount than the anticipated cost of the plant so as to allow for future expansion.

Indebtedness — The amount of indebtedness the association may assume will depend on how much money is subscribed and how much it is necessary for the association to borrow in order to carry on the business. It is by far the best plan to have a substantial proportion of the subscribed stock paid for in cash before a creamery is erected.

In case the shares are not paid for in cash, the shareholder gives to the organization his promissory note for the amount of stock subscribed for by him. These notes are in turn left as collateral in the bank where the money is borrowed. The officers will in this way secure money for erecting buildings and equipping the factory.

When the factory which starts on borrowed capital exclusively begins operations, a sinking fund is levied as provided for in the by-laws. A

levy of one cent on each pound of butter fat is usually made. When the sinking fund thus accrued from any patron's delivery amounts to the sum subscribed by him, his note is returned and a certificate of stock equal to the sum subscribed is issued to him.

Signature of Articles — The articles of incorporation must be signed by at least seven persons and acknowledged by a notary, as provided for in articles of incorporation. However, a stockholder's liability is just as great whether he signs the articles of incorporation or not.

Raising Funds — One of the important questions that must be decided is how the necessary funds for erecting and equipping a factory shall be secured. If sufficient signers are all willing to pay cash, then the matter is easily settled, but if only a part of the money needed has been subscribed and paid in cash or notes, some provision must be made for raising the balance.

One method is to borrow money for the balance needed on notes given by the board of directors for the association, and then to pay off the loan by deducting a certain amount as a sinking fund from each pound of butter fat delivered. All stockholders should be held liable until the debt is paid.

An effort should always be made to sell as much stock as possible. Especially is this true in places where competition is strong. If an association starts out with little or no debt, its chances for success are much better, for the price paid for butter fat will necessarily be less when a large sinking fund is required to pay notes and interest.

A good way to distribute the cost of building and equipping a creamery or cheese factory is for each stockholder to take stock according to the number of cows he has. This may not work out well in a locality where there are many renters, as they do not usually feel like investing much money in a factory when they may not remain long in the community.

Majority Rule — Important questions usually arise which should be fully discussed before being voted on. The majority must rule even if all are not satisfied, as harmony is one of the essentials in co-operative work.

THE BUILDING

Kind and Size — The kind and size of building will depend on local conditions. If the locality is well adapted to dairying and if the farmers are inclined to favor diversified methods, and are willing to practice co-operation, then it is advisable to erect a good, substantial building, large enough to take care of the business for some time to come. Again, if the locality is one of those where grain farming is the favored occupation, and where many are dairying because they are forced to it, then it is well to fully consider what is in store for the factory in the future, and put up a building to cost no more than the conditions warrant.

Cost of Building—The cost of building and equipment will vary with the kind of material used, the size of the building, and the distance the building materials must be transported. Prices of building materials also vary, which makes it very hard to give accurate figures as to cost; hence only general data can be given in this line.

A small creamery building constructed of brick or cement, with cement floors, will cost from \$3,000 to \$4,000, a medium sized building \$5,000 to \$6,000, and a large one from \$7,000 to \$10,000. These prices secure good substantial buildings, constructed so that they are sanitary and practically frost proof, and that is the cheapest building to put up where dairying has come to stay. There are no doubt places, where lumber is cheap and dairying in its infancy, where it may be advisable to build a frame building, and in such places a building can possibly be put up for about half what it costs to build a more substantial one.

A small cheese factory building will cost about \$500. A larger building will vary in price from \$1,000 to \$3,000, depending on building material used.

The floors should always be made of concrete which should extend about two feet up the walls to make the building much warmer, more sanitary, and durable.

Cost of Equipment—The cost of equipping a creamery will vary according to the kind and quality of machinery bought, and whether pasteurizing machinery is installed. It is safe to say that a creamery for making from one hundred to one hundred and fifty thousand pounds of butter can be equipped with good machinery for from \$1,400 to \$1,800, while the machinery for a larger plant may cost \$3,000. Equipment for a cheese factory will cost from \$500 to \$1,000.

Building Committee—When the approximate size of the plant has been decided upon, it is usually best to elect a building committee to buy material and supervise the construction of the building. Such a committee may consist of from three to five members, and any or all of them may be selected from the regular board of directors, and one or more should be familiar with building construction. It is generally advisable for the building committee to visit one or more factories, to profit by the mistakes of others. They also get ideas that will be of value to them in supervising the construction of a building.

HIRING THE BUTTER- OR CHEESE-MAKER

It is advisable to hire the butter- or cheese-maker and have him begin work at the time the foundation is laid. If he has had experience, he can assist in arranging and installing the machinery, and he is better able to locate the defects in the equipment than one not familiar with the work. The stockholders should leave the hiring of the butter- or cheese-maker to the board of directors, because they can more conven-

iently investigate his qualifications. It is well to exercise all possible care in selecting the butter- or cheese-maker, as so much depends upon his ability. Besides being able to turn out a good grade of butter or cheese from the milk or cream he receives, he should also possess tact. A man who cannot get along with the patrons will usually not succeed in building up the business, so it is best to get his record from those for whom he has worked, to see if he has the desired qualifications.

A good butter- or cheese-maker is worth a good salary. To protect both parties to the agreement and to insure ample reward for services, it has been suggested that the butter- or cheese-maker be hired at a nominal salary and in addition receive a reasonable percentage on increased income secured by turning out an extra quality of product.

THINGS WORTH REMEMBERING

The advantages of a co-operative creamery or cheese factory are many. However, the most important point to consider is that the patrons will receive more net money by operating their own factory than they will by patronizing outside concerns. No one can deny that the co-operative creameries and cheese factories are responsible for placing thousands of dollars annually in the pockets of dairymen in certain districts which they would never get without co-operative association. This assertion is proved by conditions in other places, where the net price paid to the dairymen for butter fat is as much as ten cents per pound lower than the price received by dairymen from many of the co-operative creameries.

It is very evident that the difference is due to the prevalence of co-operation in these districts and to the fact that the control of the dairy business is in the hands of the dairymen themselves. There are places where the farmers are afraid to organize and operate their own factories, for fear of outside competition. It is not at all likely that a time will come when a co-operative creamery or cheese factory with proper patronage can be seriously injured in this way. For instance, if a creamery starts in any community where there is enough raw material to operate it economically, and if everybody in the organization continues to patronize it there is no chance for any one to injure it. The success of a creamery or cheese factory does not depend upon what outsiders do, but it does depend on whether those who should patronize it stand by it or not.

It should be remembered that there is a period of development for every creamery or cheese factory, just as for any business or farm. The first year things are not so well arranged as they should be later. In the establishment of a factory, this same period of development must be looked for, and it is through this period that the co-operative qualities of people are tested. The importance of standing by the local

creamery should be made plain to every one. If the advice of this chapter is carefully followed, any community in need of a creamery or cheese factory, in the course of a few years, may have a good plant. It is a duty each individual owes to his community and state to encourage such enterprises. Don't wait for some one to come in and develop the dairy industry. Do it yourselves and get the benefit. If an outsider comes in he will be looking after his interests and not the interests of the community. A poor start in a community is hard to overcome. It is important that you start right.

ARTICLES OF INCORPORATION

Articles of Incorporation of

Know all men by these presents, the undersigned adult residents of the State of do hereby make, sign, and agree to the following Articles of Incorporation under chapter and the several acts amendatory thereof and supplemental thereto for the purpose of buying, selling, manufacturing, and dealing in milk, cream, ice cream, butter and cheese and conducting a creamery business with power and authority to do and perform all acts and things usually requisite and necessary in carrying on such business, and have organized by adopting and signing the following Articles of Incorporation.

Article I. The name of this co-operative association shall be The nature of its business shall be buying, selling, manufacturing, and dealing in milk, cream, ice cream, cheese and butter, and handling, managing, owning, operating and controlling a creamery or creameries in the usual course of such business, and to do and perform all acts and things usual, requisite and necessary on the premises; and the principal place where the business of said co-operative association shall be transacted is in in the County of and State of

Article II. The time of commencement of said co-operative association shall be the day of, 19..., and the period of its continuancy shall be twenty years.

Article III. The amount of capital stock of said co-operative association shall be dollars, and shall be divided into shares of dollars each, and shall be paid at such time and in such manner as the by-laws of this association shall direct.

Article IV. The highest amount of indebtedness or liability which said co-operative association shall at any time contract shall not exceed dollars.

Article V. The name and residences of the persons forming this co-operative association are:

.....
.....
.....
.....

Article VI. The government of this co-operative association and the management of its affairs shall be vested in seven directors, including the following officers, to-wit:

A President, Vice-President, Secretary and Treasurer, and such directors and officers shall be elected by ballot at the annual meeting of the stockholders, which shall be held on the last Tuesday in January of each year.

Article VII. The names of the first Board of Directors of this co-operative association are as follows:

- President
- Vice-President
- Secretary
- Treasurer
- Other directors
-
-
-

Article VIII. The aforesaid Board of Directors shall hold their respective offices until their successors are elected and qualified.

Article IX. This co-operative association may be dissolved at any regular or special meeting of the stockholders, provided that two-thirds of such stockholders vote for the dissolution, and each stockholder shall have but one vote in person.

Article X. This certificate of incorporation may be amended at any general meeting of the stockholders or at any special meeting called for that purpose upon ten days' notice to the stockholders.

In Testimony Whereof we, the said incorporators, have hereunto set our hands and seals this day of, A. D. 19...
..... (Seal)
..... (Seal)

(Space for 7 or more signers.)

In the presence of

.....
.....
State of }
County of } ss.

Be it remembered that on this day of
A. D. 19... before me, a Notary Public within and for said county,
personally appeared

to me known to be the persons described in the above and foregoing instrument and whose names are subscribed hereto, and severally acknowledged that they executed the same freely and voluntarily for the uses and purposes therein expressed.

.....
Notary Public.

By-Laws—1. The President shall preside at all meetings of the association. He shall have power to call special meetings of the association whenever, in his judgment, the business of the association shall require it. He shall also, upon a written request of ten stockholders or three members of the board of directors, call a special meeting.

2. The Vice-President shall perform the duties of the President when the latter is absent or unable to perform the duties of his office.

3. The Secretary shall keep a record of all the meetings of the association and make and sign all orders upon the Treasurer and pay over to the Treasurer all money which comes into his possession, taking the Treasurer's receipt therefor. The Secretary shall make a report to the annual meeting of the association, setting forth in detail the gross amount of milk and cream receipts and the net amount of receipts from products sold and all other receipts, the amount paid out for running expenses, the sums paid out for milk and cream, and all other matters pertaining to the business of the association. A like statement shall be made each month and posted conspicuously in the creamery building at the time of the division of the previous month's receipt aforesaid. The Secretary shall give bond in the sum of dollars, same to be approved by the Board of Directors.

4. The Treasurer shall receive and receipt for all moneys belonging to the association, and pay out the same only upon orders signed by the Secretary. The Treasurer shall give bonds in the sum of dollars, same to be approved by the Board of Directors.

5. The Board of Directors shall hold at least one meeting every three months for the purpose of ascertaining the true condition of the affairs of the association. At the meeting of the Board of Directors no other persons shall have a right to vote but the Directors, unless in case of a tie, when the President shall be authorized to cast the deciding vote.

6. A sinking fund shall be provided by taking from each pound of butter fat, or each hundred pounds of milk delivered, such amount as the stockholders may vote at their regular annual meeting, such sinking fund to be used only for paying insurance and taxes, buying new machinery, and for erecting new buildings or improvement of buildings; also for advancing money on supplies, and for paying interest.

7. Each stockholder shall furnish all the milk or cream from the cows he has, all milk and cream to be sound, fresh and unadulterated,

and patrons of the association not stockholders may furnish such amounts of milk or cream as they have. The association shall receive and sell such milk or cream, or manufacture the same into butter, cheese or ice cream, and receive all money from the products, and from money so received deduct such a percentage thereof as shall have been agreed upon by the association, in the by-laws or otherwise, and deduct the running expenses of the creamery, the remainder thereof to be distributed among the stockholders and patrons proportionately to the amount of whole milk or fat furnished by each.

8. All milk or cream shall be delivered at the creamery or cheese factory during the forenoon at least three times each week. It shall be sweet and in good condition, and if any be found otherwise, the operator shall have the right to reject the same. The operator shall preserve a sample of each delivery of each patron's milk or cream, testing same at proper intervals.

9. Any person knowingly sending to the factory any bloody or unhealthy milk or cream, or any milk drawn from cows within fifteen days before or five days after giving birth to a calf shall upon conviction thereof, be subject to a fine of fifteen dollars and forfeit all claim for milk and cream delivered to the factory.

10. Salaries of all officers of this association shall be fixed by the stockholders.

11. The Board of Directors shall have full authority to employ the butter- or cheese-makers, and all other help needed for the operation of the factory.

12. Whenever, from any cause, a vacancy occurs in any of the officers of the association, the Board of Directors shall fill by appointment any such vacancy, and the person so appointed shall hold the office until the next annual meeting of the association, and he shall have the same power and be subject to the same duties and liabilities as the officer regularly elected.

13. Notice shall be posted at the factory, at least ten days before any board meeting, giving notice of such meeting, and any stockholder or patron shall have the privilege of appearing before the board and presenting any grievance or other matter of interest to the association.

14. All shares shall be paid in cash or by bankable note. When a note is given to the association for stock, it may be paid by a certain percentage deducted from each pound of butter fat or each hundred pounds of milk delivered by such stockholder. Provided, however, that no certificate shall be issued or interest paid on any share of stock until it is fully paid.

15. Twenty-five stockholders shall constitute a quorum at any meeting of the association. A majority of the board shall constitute a quorum at any board meeting.

16. All members agree to deliver their saleable cream and milk to the creamery association. Because of the difficulty of estimating or fixing the extent of damage caused the association when a member disposes of his cream outside of the creamery, the same is hereby estimated and agreed upon as cent per pound of butter fat or cent per hundred pounds of milk sold outside of the association, which sum shall be allowed as liquidated damages in any action brought by the creamery association to recover damages for the breach of this agreement by any member, if the creamery company elects, as it may elect, to bring such action.

17. Each shareholder shall have only one vote, regardless of the number of shares he owns in the company.

18. Dividends declared on capital stock shall not exceed six per cent annually.

19. Any member of this association violating the by-laws or articles of said association shall forfeit his stock and membership.

20. These by-laws may be amended or changed at any meeting of the association by a two-third majority of the stockholders present and voting, but no such amendment or change shall be made unless notice of such proposed change or amendment has been given at least ten days previous to the time of voting thereon.



A Farmers' Club at Play

Courtesy of the Minnesota Experiment Station

CHAPTER VII

FARMERS' CLUBS

- I. INTRODUCTION—WHAT A CLUB IS. II. ADVANTAGES—SOCIAL—EDUCATIONAL—OUTSIDE TALENT—COMMUNITY PROBLEMS—FINANCIAL ADVANTAGES. III. CO-OPERATION OR PEASANTRY—ECONOMY IN CO-OPERATION—CLUB PROMOTES CO-OPERATION. IV. HOW TO ORGANIZE A CLUB—MEETINGS—SUGGESTED CONSTITUTION AND BY-LAWS—FORM OF PROGRAM AND ORDER OF BUSINESS. V. WORK TO DO—PACE MAKERS. VI. CO-OPERATIVE EFFORT FOSTERED. VIII. RESULTS ACCOMPLISHED BY FARMERS' CLUBS.

What a Farmers' Club Is—A farmers' club is an organization of the people in any community for the improvement of themselves, their homes, and their community. It should include in its membership the whole family, men, women, and children. Two or more families may constitute a successful farmers' club, but it is best, where possible, to include all of the people in the community. A rural school district is a suitable territory to be covered by a farmers' club. Meetings are held in the homes of the members, in town halls, or schoolhouses. There are many advantages in having the meetings at the homes of the members wherever it is practical to do so. The territory should be small enough so that all of its members can conveniently get together.

ADVANTAGES OF A FARMERS' CLUB

A good, active farmers' club will do for a rural community just what a good, active commercial club will do for a village or city, namely: it will tend to secure the united influence of the community to bring about any desired improvement, and further, it will unite the community to oppose anything that is not for its best interests. We can conceive of

no way in which a farmers' club can be detrimental to a community, while we believe that there are at least three ways in which it may be helpful, (1) socially, (2) educationally, and (3) financially.

Social Advantages—People are essentially social beings. They are not usually happy when isolated, and do not develop properly except in groups. Life on the farm tends to keep people too much to themselves. A farmers' club that will bring the people together monthly or semi-monthly furnishes a very desirable change from the ordinary routine of farm life. Everyone is interested in making the most of himself and his life. An important part of one's pleasure and development comes from meeting people and gaining the ability to mingle with them freely, without which one cannot appear at his best or get the most out of life, either socially or in a business way.

One needs to get away from his own work and home and get an opportunity to see it from a different angle. As a rule, one is better satisfied with his own conditions when he sees how others live and do. A better acquaintance with people usually results in more tolerance for their shortcomings. Many times when left to ourselves we begin to think unkindly of our neighbors, and really believe they are not what they should be. Usually a closer acquaintance and a clearer knowledge of their trials and struggles shows us that they are really better than we had thought them to be. A community in which people are interested in each other, know each other, and are boosting for each other and for the community, is a much better place in which to live than is a community in which there is mutual distrust. As a rule, knowledge of one another increases confidence. Play is an important part of one's life. One cannot do his best if every minute is devoted to work. Relaxation and pleasure are absolutely essential to good living. Clubs that will bring some entertainment, social gatherings, or other means of amusement into the community, are very important.

Educational Advantages—A good farmers' club may be of the greatest possible influence in broadening the knowledge of its members. The community has more information than any one of its farmers, and the club meeting tends to give each member the benefit of the knowledge and experience of every other member.

Another valuable feature of the club and club programs is the fact that the members when called upon to speak are put on record, and to maintain their dignity in the community they must live up to that record. For example: if a farmer is asked to tell how he has succeeded in raising the best calves in the community, he will certainly state the very best method he knows of raising calves. After going on record as standing for the best methods known in calf-growing, he certainly cannot consistently do less than put into practice on his own farm the system he has advocated. He has established his own standard, and must live up to it.

Club Work a Stimulant to Study—Being called upon to present

various topics at club meetings stimulates study. No one farm or community has in it all that is good along all lines, and being forced to study and look into what is being done in other places increases the general knowledge of the community and of each individual therein.

Outside Talent in the Meeting—A farmers' club may increase the general knowledge of its members by bringing in outside talent. Business and professional men from the nearby towns or villages can be prevailed upon to address the club. Speakers from the university or the college of agriculture and other public institutions may be secured occasionally to bring in outside ideas and inspiration.

Community Problems—A discussion of the various problems of interest to the community always tends to stimulate every good, live citizen to desire better things, and to make a greater effort to secure them. Any one who has confidence in people and in his community believes that almost all good things are possible if the necessary effort and determination are put forth to secure them. If a club can succeed in arousing in its members a desire and determination for improvement in the community, better schools, better roads, better homes, better live-stock, better farms, and better people are possible.

Financial Advantages—Business is now done in this country on a large scale. Millions of dollars and thousands of people are used in great enterprises. A farmer usually deals with people representing business interests larger than his own. As a rule, in business enterprises he deals with men who have the advantage, simply because the transaction means more to the farmer than to the other fellow with his wider field. For example, a potato-buyer in a community may buy potatoes from 200 farmers. What is 100 per cent of the farmer's business in potatoes represents one-half of one per cent of the potato-buyer's business. Consequently, a deal that means 100 per cent to the farmer means one-half of one per cent to the potato-buyer, and because the deal means very little to the buyer and very much to the farmer, the farmer is at a disadvantage. Exactly the same condition prevails in purchasing supplies. The farmer is handicapped because of the small amount of business he is doing. A farmer who can use two dozen self-binders can purchase them more cheaply than the man who uses but one. The farmer who can sell many carloads of farm products of one class can get a better price for his products than can the one who has only a wagonload or less to market.

Co-operation or Peasantry—There seem to be but two solutions to the problem of putting the farmer on an equal business basis with those with whom he has business outside of the farm. One is to increase the size of the average farm; the other is to unite the interests of several farmers owning farms of ordinary size for purposes of outside contact, in both buying and selling. The latter plan is decidedly preferable, because it does not involve the landlord and tenant or landlord and hired-help system, and

makes possible the maintenance of the family-sized farm, which is probably one of our most important American institutions. Co-operation will help to make possible the maintenance of the family-sized farm, operated by its owner, longer than it can be maintained in any other way.

Economy in Co-operation—Co-operation in marketing and in buying is, we believe, essential to the economical distribution of products. Large quantities of uniformly good products can be sold much more advantageously than can smaller quantities of products, each sample of which may be good in itself but which when brought together are not uniform. When every farm was manufacturing its own butter, and each of the hundred or more farmers in the community was trying to sell butter of a different quality, the price of butter was comparatively low. Where butter is manufactured in one plant, the manager of the creamery has at his disposal large quantities of a uniform product and can sell at the best possible price.

If the products of a community, such as grain, potatoes, and live-stock, can be made uniform by co-operation among the members of the community in production, and then these larger quantities of uniform products can be sold by one man, the same advantages that come to the large farmer, or have come to the dairy industry can be secured in other enterprises on the farm.

Club Promotes Co-operation—A farmers' club is the logical forerunner of co-operation. In the first place, it gets the people of a community acquainted and increases the confidence of each in the other. This is absolutely essential to successful co-operation. In the second place, it provides a logical means for studying carefully any enterprise that it is proposed to undertake co-operatively, so that impractical undertakings are likely to be avoided. We believe the farmers' club is a vital factor in promoting co-operation for efficiency, because it is not organized to defeat any particular class of people but to study intelligently any problem that may come up, and to take the action necessary to put any plan decided upon into effective operation.

How to Organize a Club—The organization of a club is not complicated or difficult. A good way to start the movement is for someone in a community who is interested to invite two or more of his neighbors to meet at his home or some other suitable place. If an interesting program, including singing, and speaking by the young people can be arranged, so much the better. A dinner or supper should be provided, as eating together does more than any other one thing to break down reserve, formality and distrust. It is much easier to carry out a movement of this kind after a good meal has been served. The proposition should be talked over, and it is well if a considerable proportion of those present have discussed the matter beforehand, in private conversation. No one need have any fear of joining the club, because there is no stock sold and no possibility of

loss. It is simply a mutual understanding that the people in the community will take up collectively questions of interest to the community, instead of struggling with them individually.

Meetings—Meetings should be held once or twice a month during the winter and as frequently as possible during the summer. Meetings in the homes of the members have at least two advantages: (1) attendance is stimulated by the feeling of obligation to the host and hostess, and (2) the knowledge that the club is soon to meet on a given farm or in one's home is a great stimulus to housecleaning and decoration and corresponding outdoor activities.

Suggested Constitution and By-laws—The following simple constitution is suggested as suitable, but the form of constitution is not important:

Constitution—ARTICLE I. *Name and Object.*

Section 1. The name of this association shall be the Farmers' Club of

Sec. 2. The object of this association shall be to improve its members, their farms, and their community.

ARTICLE II.—*Membership*—Sec. 1. Any one in good standing may become a member of this club by paying the annual fee of \$.....

Sec. 2. When the head of a family joins the club any member of his family may become an active member without paying additional fees.

Sec. 3. One-third of the active members shall constitute a quorum for doing business at any regular meeting.

ARTICLE III.—*Officers*—Sec. 1. The officers of this association shall consist of a president, a vice-president, a secretary, and a treasurer. They shall be chosen because of their business ability rather than their popularity.

Sec. 2. The officers of the club become the executive board and shall constitute the program committee.

Sec. 3. The executive board may call a special meeting at any time by giving three days' written notice.

Sec. 4. The officers of this association shall be elected annually, and by ballot, at the regular annual business meeting, and shall hold office until their successors have been elected and qualified.

ARTICLE IV.—*Meetings*—The club shall hold an annual meeting the Regular meetings of this club shall be held on the of each month at the home of some member or at such place as shall be designated at a previous meeting, or by the executive board.

ARTICLE V.—*Amendments*—This constitution may be amended at any regular meeting by a two-thirds vote of the active members.

By-Laws—Sec. 1. The duties of each officer named in the constitution shall be such as usually pertain to his position.

Sec. 2. All other duties shall be performed by the executive and program committees.

Sec. 3. The club shall aid and further business associations among its members; particularly such associations as pertain to the purchase of necessary supplies, and the purchase and management of live-stock and agricultural and garden products.

Sec. 4. From time to time the club shall give entertainments and hold meetings under direction of the program committee, for the benefit of its members and of those whom they may invite to attend.

Sec. 5. Any members, after due hearing, may be expelled from the club by a majority vote of active members at any meeting, without a refund of dues.

Sec. 6. These by-laws may be amended at any regular meeting by a majority vote of active members upon one month's written notice.

Form of Program and Order of Business—1. Meeting called to order by presiding officer.

2. Instrumental music or a song by the club.

3. Roll call of members by the secretary.

Responses should take some other form than the mere word "present." The program committee or the president should previously designate the topic of response for roll call. The responses should be entertaining and instructive, but not too long. The following topics may be suggestive:

What I Have Done for the Club Since the Last Meeting.

How I Have Added to the Value of My Farm This Season.

What I Consider My Most Profitable Crop.

4. Reading and approval of the minutes of the last meeting.

5. Recitation by one of the younger members.

6. Discussion of timely farm topics led by a club member or some other speaker, followed by questions and a general discussion.

7. Reading or music.

8. Discussion of another farm or household topic illustrated by a demonstration if possible.

9. Question box. Timely and practical questions should be previously prepared by members and placed in the question box. Each question should be read and answered separately, the president calling upon some member or members to answer them.

10. A "For Sale" and "Wanted" box may also be provided. A member having something for sale or wishing to buy or hire something should list the same on a slip of paper, sign his name, and place it in the box. These slips should all be read at some time during the meeting. An exchange of these lists between clubs will be mutually helpful.

11. Reading of program for next meeting.

12. Report of executive committee.

13. Unfinished business.

14. New business.

15. Closing exercises and adjournment.

If desirable, the program may be divided into two parts by an intermission. Readings and recitations may be of a humorous nature to add life to the program. Variety is essential, and whenever possible a discussion of woman's work should be made a prominent feature of the program.

It may frequently be advisable to limit the time devoted to the discussion of each topic, especially if speakers are likely to waste a great deal of time. Matters pertaining to the welfare of the club and the mutual benefit of the members should be given constant thought. Debates may be held occasionally to interest the young people. Where clubs include the entire family in the membership, a basket lunch will add to the interest in the meeting, but it should be simple so as not to be a burden to the housewives.

The main point to consider is that there should be a good, live, snappy meeting. Short, pointed talks followed by general discussions are very much better than long talks. Music, humorous recitations or readings, and topics of general interest, as well as the more serious business problems of the community, should be given a place on the program. The monthly topics furnished by the agricultural extension division of your university will be found helpful in preparing the program.

WORK TO DO

No organization can exist very long unless it is doing something. From the start the club must be made of value to the community socially, educationally or financially, and in any event someone must do some work. As a rule those who do the most for the club get the most out of it. The regular meetings, if made interesting, will be made valuable socially and educationally. Every class of people in the neighborhood or in the club membership should be considered on the program. Wholesome entertainment is often as important as profitable business.

Pacemakers—A few clubs have adopted a plan of appointing pacemakers or specialists along the various lines of interest in the community. The following list is suggestive as to lines of work and methods of procedure:

Road-Builder—When chosen, it shall be the duty of the road builder to spread the gospel of good roads in as many ways as possible. He should be prepared to answer all road questions that may come up at club meetings or at other times. He should endeavor to set a good example by attention to all highways adjacent to his farm.

It is suggested that he, in conjunction with the other club members, designate two or three miles of adjacent highways for demonstration purposes, and endeavor to make it as good as possible.

Corn Crank—The selection of the corn crank should be made with a view to getting someone who is enthusiastic for corn, and who has made a marked success in corn growing. He should be an authority on the varieties to be planted, the preparation of the seed and the land, the planting, and the

subsequent cultivation. He should have a corn-breeding plat or at least a seed-corn plat. His field of corn should be a model in every way and a tribute to the locality.

Flower Queen—The selection of a flower queen should be made with a view of having someone well informed in the culture of flowers. She should be qualified to answer questions concerning this work, and to make her home flower garden a demonstration of the possibilities in flower culture. She should be capable of giving advice as to varieties practical for farm growing and easy to grow. She should also be able to advise regarding the purchase of seed, and might well arrange to get up club orders for seeds.

Dairy Wizard—The man selected for dairy wizard should be a man who has a dairy herd and ample opportunity to demonstrate methods



Looking for Nodules on the Roots A Farmers' Club Studies Alfalfa and Other Crops in the Field.

Courtesy of the Minnesota Experiment Station

and possibilities. He should be well informed about dairy practices, and if possible should arrange to keep a daily record of each cow in his herd.

Alfalfa Shark—The alfalfa shark should grow a field of alfalfa, should encourage its growth by others, and should make himself an authority on its culture, curing, and use in his community. He should adopt the slogan, "An acre or more of alfalfa on every farm," and should preach alfalfa in season and out of season.

Potato King—When elected, the potato king is expected to set the pace as to varieties to plant, preparation of the land, storing and preparation of the seed, time of planting, cultivating, harvesting and marketing. In fact, he is to be the club's source of potato information, and his field should be a demonstration of what may be done with potatoes in the locality.

The Booster—The booster should carry the responsibility of arousing community spirit; of devising various ideas that will arouse club members to community action; and of fostering such movements as tend to attract the public to the community and to the club.

Poultry-Keeper—The poultry-keeper should be some man or woman who is an enthusiast on poultry. His duties should be to maintain an up-to-date poultry plant, and to be informed on the general care, management, and improvement of poultry.

Business-Getter—The man chosen for business-getter should be especially qualified along business lines. His duties should be to look after the marketing problems of the club, and to see what steps could be taken to enable the club members to get their supplies most economically.

Home-Maker—The position of home-maker should be filled by some woman in the club who is a successful home-maker and who can spend some time in promoting the idea of better homes in the community.

It is proposed that each club arrange to select several pacemakers, and that each pacemaker plan to carry on some demonstration along his line of work. The agricultural extension division of your university will assist each pacemaker in planning his duties and his demonstration work. It is suggested further that the club arrange for a demonstration day, at which time the extension division will furnish speakers, the pacemakers will present reports, and a general inspection will be made of the demonstrations and the club work.

It would be entirely practical to choose as many pacemakers as there are members of the club, assigning to each one some particular phase of the community activity in which he is especially qualified. Each of these pacemakers, by specializing on one subject for a few months or for the year, would really become very proficient in that line and be able to be of great help to other members of the club. These pacemakers should be ready at all times to take part in the program and present briefly some development in their particular line of work. This plan has been found to help very much in getting up good, live programs.

Co-operative Effort Fostered—Various undertakings may well be fostered by the farmers' club. The members should decide on one variety of potatoes or other market crop to produce, and then find some way of marketing it jointly. One or two leading breeds of each kind of live stock should be adopted by the club. Pure-bred sires may be purchased and used co-operatively, to the advantage of everyone. Feed, flour, cement, and other supplies that can be handled in large lots, may be purchased co-operatively, usually at a considerable saving.

The question of organizing a live-stock shipping association is

worth considering where live stock is an important factor. Home conveniences, and a beef club for supplying fresh meat should be considered. When dairying is important, the organization of a cow-testing association is valuable. In any neighborhood, community effort along the line of road improvement is worth very careful consideration. Such



A Meat Club

One Farmers' Club has Solved the Question of Fresh Meat Supply on the Farm.

Courtesy of the Minnesota Experiment Station

matters as organizing a creamery, cheese factory, or farmers' elevator, the purchase of a stallion, or the introduction of a general drainage system for the community, should be considered by the club and acted upon only after all the facts in the case are known. One of the latest attempts of a farmers' club is to organize a co-operative laundry in connection with a co-operative creamery. In short, every enterprise connected with the farms, homes, or schools may be profitably considered by the club.

Results Accomplished by Farmers' Clubs — At Dassel, Minnesota, for example, a farmers' club has done many good things for the community. In the first place, the members decided to get some pure-bred sires, but before getting them it was thought best to have all herds tested for tuberculosis. Instead of each individual hiring a veterinarian independently, the club hired a veterinarian to test some 300 head of cattle, thus systematizing the work and reducing the cost. For several years they have conducted work in testing their herds for milk production. This work has resulted in doubling the production in some cases without increasing the size of the herds. They have taken up and successfully carried out a plan of marketing their eggs in cartons, through which system they have received considerably more for them than they would have received under the old system of marketing. Two years ago they reorganized as a farmers' corporation, and since then have conducted four lines of work: cow-testing, egg-marketing, live-stock shipping, and seed-grain marketing.

Another farmers' club took up live-stock shipping. The following statements show the growth of this undertaking:

Summary for Five Years

1st year—Carloads, 14;	Gross receipts.....	\$ 11,599.25
2nd year—Carloads, 35;	Gross receipts.....	39,569.27
3rd year—Carloads, 81;	Gross receipts.....	102,163.35
4th year—Carloads, 104;	Gross receipts.....	114,764.56
5th year—Carloads, 146;	Gross receipts.....	181,544.10

\$449,640.53

Summary of Report for Fifth Year

Net paid to farmers for stock.....	\$171,190.59
Total expense	10,318.77
Increase of sinking fund.....	34.74
	<hr/>
Gross receipts	\$181,544.10

In one locality several farmers' clubs united to dispose of their potato crop. They succeeded admirably, and since then have organized a potato-shippers' association, have built a warehouse; and have also organized a live-stock shippers' association. Both organizations are progressing successfully.

One farmers' club combined the feed orders of its members, buying over 100 tons, and thus saving over \$250.

The farmers' club in another district was an active agent in bringing about the organization of a co-operative laundry in connection with the co-operative creamery.

There are now in Minnesota, for example, more than 800 farmers' clubs, alive and active. The social, educational, and financial results from these clubs are very great. There should be a farmers' club in every rural school district throughout the country.



CHAPTER VIII

THE SCIENCE OF DAIRYING

- I. WHY THE BABCOCK TEST IS USED. II. STEPS IN THE BABCOCK TEST—MIXING AND SAMPLING—PRESERVING SAMPLES—FILLING THE PIPETTE—FILLING THE TEST BOTTLE—ADDING THE ACID—MIXING THE ACID AND MILK—WHIRLING THE BOTTLES—READING THE PER CENT OF FAT—CLEANING THE BOTTLES. III. CALCULATING WEIGHT OF FAT IN MILK. IV. SAMPLING AND TESTING THE MILK OF DIFFERENT COWS. V. MONTHLY OR DAILY WEIGHING OF THE MILK—SAMPLING MILK AT THE BARN FOR THE FAT TEST. VI. TESTING SKIM MILK BY THE BABCOCK TEST. VII. TESTING CREAM ON THE FARM. VIII. READING CREAM TESTS. IX. TESTING THE ACCURACY OF BABCOCK TEST BOTTLES. X. HOW COMPOSITE SAMPLES ARE MADE. XI. THE OVERRUN—FACTORS INFLUENCING OVERRUN—OVERRUN FROM CREAM—OVERRUN TABLE—BUTTER—CHEESE—CONDENSED MILK. XII. CALCULATING DIVIDENDS BY THE FAT TEST.

WHY THE BABCOCK TEST IS USED

Before 1890, when the Babcock test was invented, no simple, accurate method was known by which the farmer could measure the richness of the milk or cream which he sold, or of the skim milk which remained. At creameries and cheese factories, each patron was paid in proportion to the weight of milk delivered. It was then commonly believed that 100 pounds of milk from one cow would make as much butter or cheese as an equal weight of milk from any other cow. Cows were valued according to the number of pounds of milk they produced.

It is now well known that the weight of butter or cheese that can

be obtained from a given quantity of milk depends to a great extent upon the weight of fat present in the milk. For this reason, milk and cream are now both weighed and tested for fat by the Babcock test at most factories. Patrons are paid according to the test, that is, according to the weight of fat in the milk delivered by them.

The relative value of different cows in a herd is now determined by weighing and testing the milk of each. Many cows produce a profit of from \$25 to \$50 or more per year, but in almost every herd tested, some "robber" cows are found whose milk does not pay for the feed

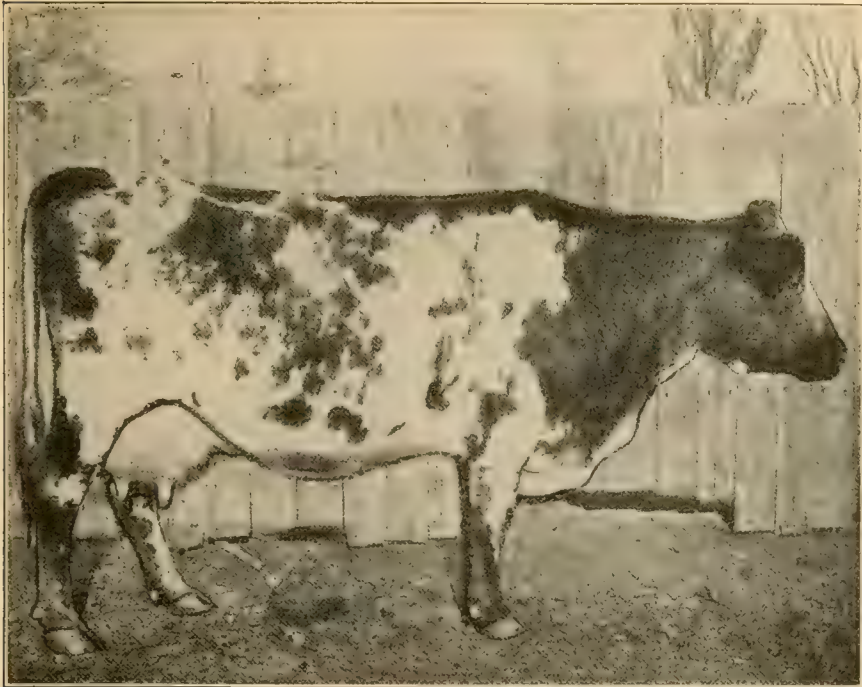

Fig. 1.—This cow milked 304 days; 8,132 pounds milk; average test, 4 per cent fat; 325 pounds fat; value of fat at 25 cents per pound, \$81.25. Cost of feed, etc., \$40.00; profit, \$41.25. Many a splendid producer is sold for much less than her value because her true worth is not known.

Courtesy of the Wisconsin Experiment Station.

consumed by them. By replacing the poorest cows with better ones, the herd will be improved. Compare Figs. 1 and 2.

Although there is only about one-eighth as much fat in separator skim milk as in milk skimmed from crocks or shallow pans, it should be tested for fat frequently to see if the separator is skimming as closely as it should. Ordinarily separator skim milk tests about five-hundredths (.05) of one per cent, but if, by running the separator too slowly or separating the milk when too cold or for other reasons, the skim milk should contain .15 per cent or more of fat, the loss may amount to 0.15

or \$2 per cow per year. This amount of money will more than pay for the entire expense of installing and operating a Babcock test. Although the fat in the skim milk is not wasted when fed to pigs or calves, yet it is much more profitable to sell butter fat as cream or butter than it is to make veal or pork out of it.

The dairyman who buys and uses a Babcock tester will soon find that he is aided in three ways: first, by testing his cows he will be able to weed out the "robbers" and retain his best producers for breeding, and milk and butter fat production; second, by frequently testing the milk or cream before it is sold he should have a check upon the test made at the factory; third, by occasionally testing the skim milk he will be able to see that no butter fat is being wasted.

On many dairy farms the Babcock test is saving annually many times its cost, and at the same time is enabling farmers to select their best cows and improve their herds as rapidly as possible. A Babcock tester should be used regularly on every dairy farm and in every rural school in the country.

STEPS IN THE BABCOCK TEST

1. Mix the milk thoroughly and take out a small sample.
2. Do not let the sample evaporate or curdle before testing.
3. Fill the 17.6 cc. pipette to the mark with milk.
4. Empty the pipette without loss into a Babcock test bottle.
5. Add sulphuric acid from the measuring cylinder to the test bottle.
6. Mix the acid and milk thoroughly by shaking the bottle.
7. Place bottles in the centrifuge, cover and whirl 5 minutes.
8. Add hot water up to the neck and whirl one minute.
9. Add hot water again so that the neck is nearly filled and whirl one minute.
10. Read and record the per cent of fat in the neck of the test bottle.
11. Empty the test bottles and wash thoroughly, using alkali water to take out fat.

Mixing and Sampling Milk— Provide a quart or more of milk, with which to practice sampling and testing. Mix it thoroughly by pouring several times from one vessel to another, or by stirring vigorously. Larger quantities of milk require more stirring. While the milk is still in motion, dip out half a teacupful and pour this at once into a small, clean, dry bottle. Fill the bottle nearly full, and stopper tightly to prevent evaporation. After stirring the milk again for a short time, take out another sample, place it in another bottle and stopper tightly as before. If the milk was thoroughly mixed each time, these two samples will show exactly the same per cent of fat by the Babcock test, provided the test bottles are accurately marked on the neck. Label the bottles with the name of the cow or owner.

The small sample taken for the test must contain exactly the same proportion of fat as the entire contents of the pail or can. If milk stands for

even a few minutes, the cream will begin to rise, and the top layer on the can will contain more fat than the rest of the milk. If the top part is used for the test, it will indicate a higher per cent of fat than is present in the entire lot of milk. It is incorrect to take a sample for testing out of a pail, can or bottle without first thoroughly mixing the milk by stirring, or pouring it from one vessel to another. When two people get different results in testing any lot of milk, it is usually because one or both of them did not first stir the milk long enough to get it thoroughly mixed before taking the sample. In any case where the accuracy of the results must be proven, it is

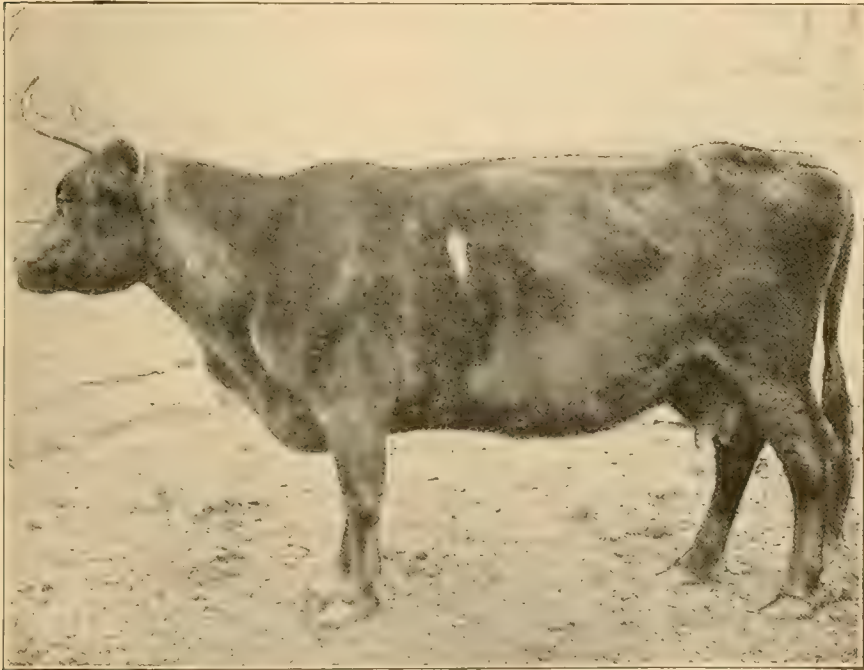

Fig. 2.—This cow milked 209 days, 4,061 pounds milk; average test, 3.9 per cent fat; 158 pounds fat; value of fat at 25 cents per pound, \$39.50. Cost of feed, etc., \$40.00; no profit. It is a waste of time to milk such cows.

Courtesy of the Wisconsin Experiment Station,

important that two or more separate samples be taken at different times while stirring. Each sample should then be tested by itself. If the results differ, it shows some error in the work, and if the difference is over one-tenth of one per cent, the sampling and testing should be repeated in a more careful manner.

Preserving Samples—If it is necessary to keep the milk samples several hours or days before testing, a preservative should be added to prevent curdling, and the bottles should be kept tightly stoppered. The preservative most commonly used is corrosive sublimate, which is a poison. It is sold in tablet form, in boxes containing 100 or 1,000. Each tablet also

contains some pink coloring matter, so that everyone may know that the milk, so colored, contains poison, is unfit to drink, and must not be fed to stock. For half pint or smaller samples, add one small preservative tablet to each bottle of milk and shake until dissolved. Formalin and bichromate of potash are other preservatives which may be used instead of the tablets. All these are poisonous and must be kept out of the reach of children.

Filling the Pipette—The milk test bottle and pipette (Fig. 3) are cleaned with hot water and if necessary with washing powder or soap, and thoroughly rinsed with clean water before using.

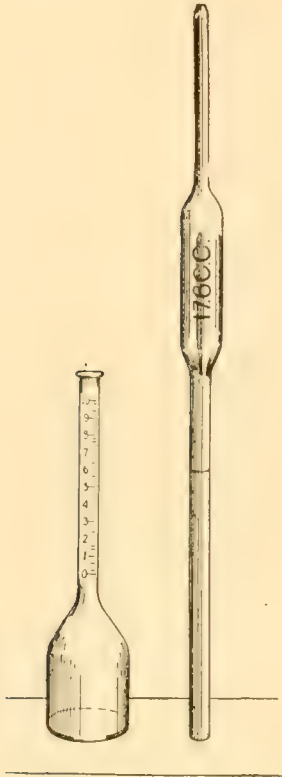

Fig. 3.—A pipette holding 17.6 cc. milk and a test bottle for milk, used in the Babcock test.

Before taking any milk out of the small sample bottle with the pipette the sample bottle should be well shaken, so as to mix the cream all through the milk. It should be remembered that cream is always rising in milk. If lumps of butter fat appear on the surface of the milk, warm the bottle and contents to about 100 degrees F., and shake again. Immediately put the narrow tip of the pipette into the milk (where it is still in motion); and, with the mouth, suck the air out until the milk rises in the pipette, above the mark on the neck. Quickly place the forefinger over the upper end of the pipette, before the milk runs down below the mark. If the finger is dry or nearly so, it is easy, by changing the pressure on the end of the tube, to let the milk run down slowly and to stop it exactly at the mark.

Filling the Test Bottle—The tip of the pipette is placed in the top of a test bottle, held in an inclined position, as shown in Figure 4, and the milk is allowed to run down one side of the neck of the bottle, without filling the neck completely, or preventing the escape of air. In this way exactly 18 grams (17.6 cc.) of milk are transferred to the test bottle without loss. It is well for a beginner to practice with pipette filled with water until the flow can be readily controlled with the forefinger. If a portion of the milk containing preservative should be drawn into the mouth, spit it out and rinse the mouth with clean water. After the samples of milk have been placed in the test bottles, they can be set aside for a day or a week, if necessary, and the testing can be finished at any time without affecting the result.

The milk in the test bottle should not be warmer than 60-70 degrees Fahrenheit just before the acid is added. For this reason, milk fresh from

the cow, or skim milk or cream from the separator, or whey from the cheese vat must be cooled before acid is added. Buttermilk or cream taken from the churn, and tested while yet at 50-60 degrees, gives clear fat columns, and correct results.

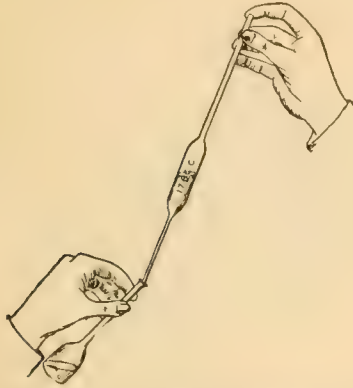

Fig. 4.—On slowly releasing the pressure of the finger at the top of the pipette, the milk runs, without loss, into the test bottle.

or a piece of sheet lead. Liquids containing sulphuric acid should not be thrown where live stock can come in contact with them, but can be poured with safety into an earthen jar or into a clay drain tile set on end in the ground. The sulphuric acid bottle should be kept stoppered because the acid readily absorbs moisture from the air and thus becomes weakened. Always add acid to milk in the bottle and never add milk or water to the strong acid.

As sulphuric acid will quickly eat holes in the clothing and cause blisters on the skin, the greatest of care should be taken not to spill it. To observe its effect, put a few drops of the acid on each of two pieces of paper, or cotton or woolen cloth. With a little water, rinse the acid as quickly as possible from one piece, and note whether it is spotted where the acid fell. Leave the other piece for a few hours and then wash it.

When handling sulphuric acid wear an apron and have a supply of water ready for washing acid from the clothing, person or furniture upon which it may be spilled in case of an accident. After thorough washing with water, a little household ammonia, or baking soda, or lime water may be applied and washed off with more water. *Sulphuric acid must not be measured in the pipette* because of the danger of drawing it into the mouth.

Mixing the Acid and Milk—The sulphuric acid in the test bottle weighs more than the milk, and the acid goes to the bottom at once, forming a clear layer, which may become brown where it touches the milk. As

Adding the Acid—Sulphuric acid, of specific gravity 1.82, sold for the Babcock test, can be obtained at any drug store or from dealers in dairy supplies. The acid, at 60-70 degrees, F., is measured in the little acid cylinder, shown in Figure 5, which, when filled to the mark holds just 17.5 cc.

The cylinder is then emptied into the test bottle, which is held in an inclined position, as shown in the figure, to permit escape of air, and to avoid spilling the acid. Since this acid destroys wood and nearly all metals, the bottle of acid and the little measuring cylinder should be kept standing on a brick, a piece of stone,



Fig. 5.—In pouring acid into the test bottle, incline the bottle a little, to avoid spilling acid on the hand.

soon as the acid is all poured in, the test bottle should be held by the neck and shaken in a circle so as to mix the acid and milk. See Figure 6. Keep the liquid out of the neck of the bottle, while shaking it, to prevent loss. During the filling and mixing, point the neck of the bottle away from the face, so that no drop of acid may be thrown into the eyes.



Fig. 6.—To mix the acid and milk whirl the bottle in a circle until the contents are of a uniform brown color.

Courtesy of the Wisconsin Experiment Station.

As the shaking is continued, the mixture turns to a uniform brown color and becomes quite hot. Be sure to mix thoroughly. Write the number of the sample with a common black lead pencil on the roughened spot on the side of the test bottle.

When there is much testing to be done, it is better to first measure all the milk samples into the bottles, labeling each. Shake each bottle immediately after adding acid to it and whirl the whole set while all are hot. If the test bottles become cold after adding acid and before whirling, they should be warmed again by placing for about 15 minutes in water heated nearly to boiling.

Whirling the Bottles—Having placed the bottles opposite each other in the whirling machine (called a centrifuge), close the cover and turn the handle for about five minutes at the speed indicated in directions furnished with the machine. Allow it to stop gradually. See Fig. 7.

The centrifuge is generally enclosed in an iron box, so that if anything should break while the machine is running, no one would be injured by the flying pieces. The cover should always be kept closed while the machine is running. The wheels will turn more easily and last longer, if they are oiled daily when in use. The bottles travel around in circle from 700 to 1,000 times a minute, moving about 40 miles per hour. The machines are not all of the same size and some go faster than others. A weight hung by a string 22 inches long will swing back and forth about 80 times per minute, and about 70 times if the string be made 24 inches long. Such a pendulum, once adjusted to the right length with the aid of a watch, is a help in running the tester at the right speed. In large factories where many samples are tested, the centrifuges are run by steam or electric power. (See Fig. 8). In such cases speed indicators are used to run the machines at the proper speed. Running faster than directed is likely to break the bottles. Running too slow may cause the test to read too low.

The cover is opened when motion has stopped, and with the pipette a small amount of hot, soft water is added to each bottle, without taking it out of the pocket. The bottles are thus filled to the bottom of the neck, and the machine is then closed and run at full speed for another minute. More hot water is added with the pipette, bringing the fat up into the neck,

between the top and bottom of the scale of figures, and the machine is closed and run another minute or two, for the third and last time.

Some operators prefer to add enough water after the first whirling to bring all the fat up into the neck and whirl the bottles only two times in all. It is always desirable that the layer of fat after whirling should be clear and

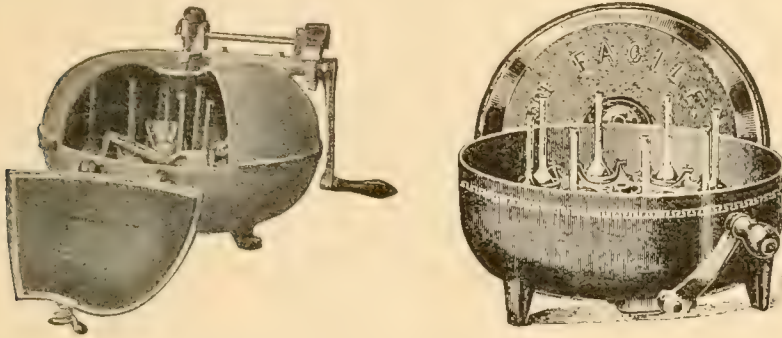

Fig. 7.—Different styles of hand testers now on the market.

free from watery bubbles or solid particles before it is brought up into the neck for reading. A little extra shaking after the first addition of water is sometimes helpful.

The bottles are then taken out of the machine and the per cent of fat is read from the neck of each bottle, while still hot and before the fat solidifies. To prevent cooling the bottles may be set in water at 130 or 140

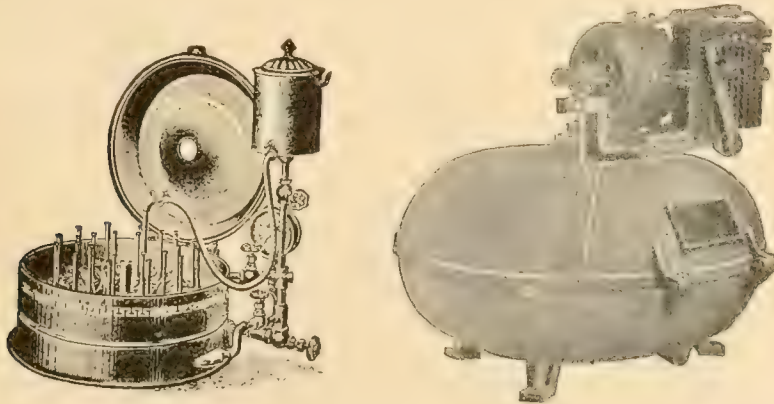

Fig. 8.—Testers run by steam or electric power, used in large creameries

degrees until each has been read, but this is not commonly done in milk testing.

Reading the Per Cent of Fat—In reading the per cent of fat in the neck of a milk test bottle, readings are made at the extreme top and at the bottom of the fat column. Subtracting the smaller of these figures from the larger gives the per cent of fat in the milk. By the

aid of a pair of dividers, the subtraction is avoided, and the per cent of fat is read directly from the neck of the bottle.

To use the dividers, adjust the points to the top and bottom of the fat column as shown in Fig. 9; and then, without changing the distance between them, place one point at the bottom of the scale of figures, and read on the scale the position of the other point as in Fig. 10. This gives the per cent of fat in the milk.

Fat solidifies at about 100 degrees. Warming the fat in the neck of a test bottle from 110 to 150 degrees makes it expand about 1.5 per cent of its volume. This expansion amounts to about .05 per cent fat on a test reading 3.5 per cent fat, and hence it is too small to be of importance in milk testing. However, in cream testing, it is necessary to regulate the temperature with care.

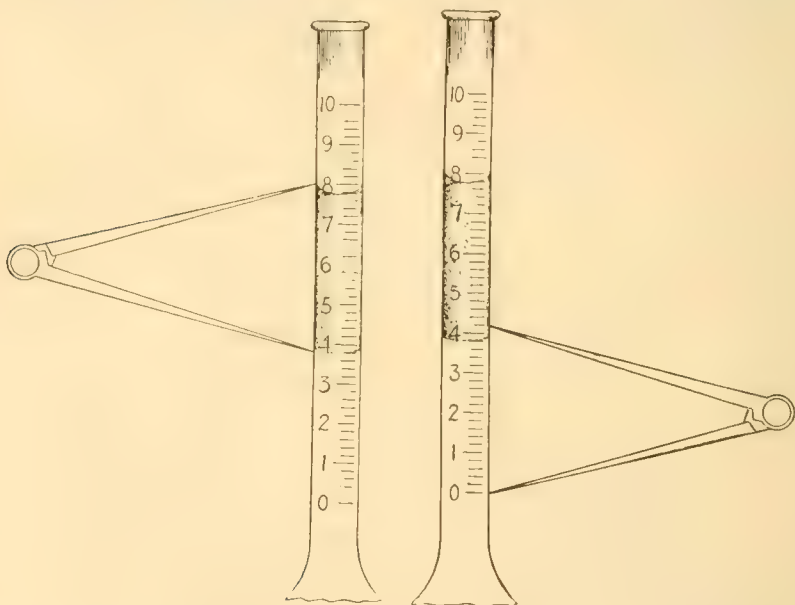

Figs. 9 and 10.—Showing dividers in first and second position for reading test.

The fat column when read should be light brown and uniform in color. Black or dark colored sediment appearing below or mixed with the fat caused by too violent action of the acid on the milk may interfere with correct reading. To avoid this trouble in repeating the test, the milk may be cooled if either milk or acid is above 60 or 70 degrees; or a little less acid may be used in the test. Even with strong acid with a specific gravity of 1.84, a clear test can be obtained by using only two-thirds to three-fourths of a measure full of acid.

Light colored curdy material, sometimes seen floating just below the fat column when the test is read, consists of a mixture of a little fat with some other milk constituent which was not fully dissolved by the acid. Where much of this light colored curd occurs, it is likely to contain consider-

able amounts of fat, so that the reading of the fat column will be too low. The cause of this trouble may be that the acid and milk were too cold when mixed, or that they were not sufficiently mixed by shaking and whirling, or that the acid used was too weak. To avoid such trouble, the milk may be warmed, or a little more than the usual proportion of acid may be used.

Bubbles of foam at the top of the fat column are sometimes caused by the use of hard water. To avoid this, use soft water for testing.

The beginner should practise sampling and testing milk until he is well acquainted with every step described above. He should be able to make several tests on the same sample of milk which do not differ in reading by more than one or two-tenths of a per cent.

Cleaning the Test Bottles — Having read and recorded the per cent of fat from each test bottle, empty all of the bottles while still hot. The white sediment in the bottom is most easily removed by shaking the bottle while the hot acid is running out. Wash the bottles thoroughly, using hot water and soda, washing powder, or soap if necessary, to remove all of the fat. Finally rinse with clean water. Small specks left sticking to the inside of the neck of the bottle can be removed by means of a brush sold for the purpose or with a bit of cloth fastened to the end of a wire.

Calculating Weight of Fat in Milk — To find the pounds of fat in any quantity of milk, it is necessary, first, to weigh the milk; second, to test the milk to find the per cent of fat; and third, to multiply the weight of the milk by the per cent of fat and divide by 100.

For practice, one learning to make the test may figure the pounds of fat in

25	pounds of milk	testing	5.0%	fat.	Ans.	1.25	lbs. of fat.
37	"	"	"	"	"	"	"
70	"	"	"	"	4.0%	"	"
97	"	"	"	"	3.5%	"	"
427	"	"	"	"	3.8%	"	"
					3.9%	"	"

SAMPLING AND TESTING THE MILK OF DIFFERENT COWS

Cow testing is of great importance. Any one who knows how to handle the Babcock test can successfully test the cows in the home herd. Thousands of dairy farmers are now testing their own cows, or have joined cow testing associations in order to have the work done for them, at a cost of about one dollar a year, for each cow in the herd. Very few dairymen who have had their cows tested for a year or more are willing to discontinue the work. For by this testing, the owner knows the weight of milk and of butter fat produced by each cow. This enables him at the end of the season to pick out his most profitable cows, whose calves should be kept to improve the herd, and also to know which are the poorest cows in the herd which should be replaced, because in very many cases they do not pay for their feed.

For cow testing, it is necessary to weigh and test the night's and morning's milk of each cow, once in each month. This is the plan followed by

most cow testing associations, and it is also suitable for farmers who do their own testing. In addition to the Babcock test outfit, a milk scale is needed, preferably one that reads in pounds and tenths instead of pounds and ounces. (Fig. 11.) It should weigh up to 30 pounds and should have a loose red index which can be set at zero when the milk pail is empty, thus giving directly the weight of milk obtained from each cow. The scale shown in the figure can be bought for \$3.50 or less. It should be hung in a well lighted place, and each cow's milk should be weighed just before it is strained into the milk can. The record of the weights for a month is kept on a sheet of paper which may be ruled as shown in Figure 12, and tacked up on the wall or on a swinging shelf.

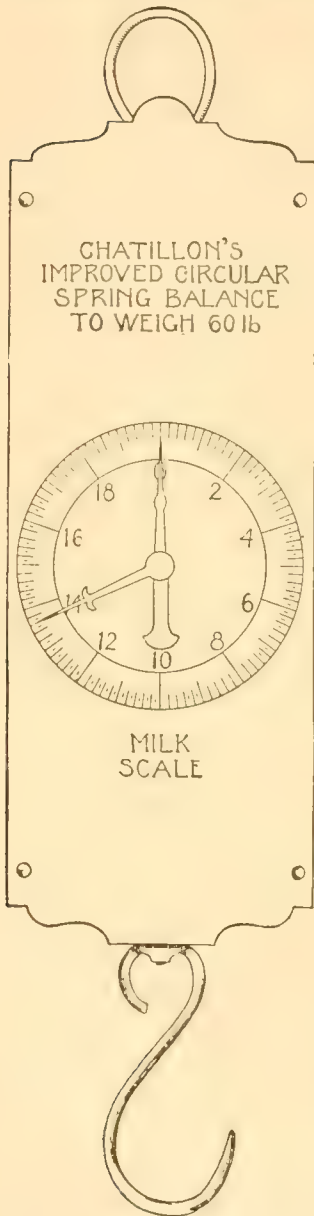

Fig. 11.—A scale for weighing milk.

Monthly or Daily Weighing of Milk —

After buying the milk scale and using it a few times, many find it so little work that they prefer to weigh the milk every day for the reasons given below, although the testing is done only one day in each month. The daily weighing of milk enables the owner: (1) To feed each cow in the most economical way according to her flow of milk, and to observe how the flow of each cow is affected by changes of feed or other condition. It has been found a good working rule to feed as many pounds of grain feeds per day to each cow as she produces pounds of butter fat in a week, or one-fourth to one-third as much grain as she gives pounds of milk daily, the amount depending upon the per cent of butter fat in the milk. Each cow should receive as much roughage as she will eat up clean and a portion of this should be of a succulent nature, like grass, silage, soiling crops or roots. (2) To quickly detect any sudden decrease in milk flow, which may indicate illness, and to give prompt treatment to such cases. (3) By comparison of one day's milk flow with

another, the owner can be sure that the milk used once a month for fat testing is normal in quantity. (4) Daily weighing of the milk shows which milker is doing the best work. It stimulates interest in the cows,

COW'S NUMBER	Month.....																Year.....	FARM MILK RECORD	Owner's Name.....
	1	2	3	4	5	6	7	8	9	10	11	12	13	14	15	16			
DATE.	AM	PM	AM	PM	AM	PM	AM	PM	AM	PM	AM	PM	AM	PM	AM	PM			
1																			
2																			
3																			
4																			
5																			
6																			
7																			
8																			
9																			
10																			
11																			
12																			
13																			
14																			
15																			
16																			
17																			
18																			
19																			
20																			
21																			
22																			
23																			
24																			
25																			
26																			
27																			
28																			
29																			
30																			
31																			
Total AM&PM																			
Total																			
Test																			
Lbs Butter Fat																			
Value																			

Fig. 12.—Similar record sheets can be purchased from dealers or made at home.

their milk yield, their care, and in the possibility of improving existing conditions, by skillful feeding, by grading up the herd and in other ways.

If the milk is weighed daily, the total weight of each cow's milk at the end of the month is obtained by adding up the daily weights. If the milk is weighed only on one day in the month, this weight is multiplied by 30 or the actual number of days in the month to get the total weight for the month. To get the weight of butter fat produced each month, the weight of the month's milk is multiplied by the per cent of butterfat which it contains, found by sampling and testing each cow's milk for fat.

Sampling Milk at the Barn for the Fat Test—This may be managed in various ways, according to the facilities at hand, and the choice of the owner. Two ways will be described, either of which gives results sufficiently accurate to show unmistakably which are the best and which are the poorest cows in the herd. In every case the day selected for the fat testing should be as near the middle of the month or test period as possible.

First Method—A small tin sampling dipper, holding about one ounce, and a set of 2-ounce or 4-ounce sample bottles (one bottle for each cow) with corks and labels, will be needed. A small box or frame, with partitions to prevent the bottles from tipping over is a convenience. On the day selected for fat testing, the set of sample bottles and the sampling dipper should be carried to the barn. The pail of milk from each cow is weighed as usual, and is then stirred well. While the milk is yet in motion, a dipper full is transferred from the pail to the sample bottle, which is then labeled with the cow's name or number, and closed tightly.



Fig. 13.—
Sampling
Dipper.

Since night's and morning's milk are apt to test differently, it is desirable that at the next milking, a second sample of each cow's milk be transferred in the same manner to her sample bottle. The bottle is then shaken with a rotary motion to wash down and mix in any cream that may have risen or stuck to the sides of the bottle. A 17.6 cc. pipetteful of the well mixed sample is transferred to a Babcock test bottle, and the tests are finished in the usual manner. If a test should be lost, another portion from the same sample bottle can be tested. In this way, only one Babcock test bottle is used for each cow, and the reading of the test represents the average per cent of fat in that cow's milk for the month. Some prefer to run two test bottles on each cow's milk, thus securing greater accuracy.

No preservative need be used if the bottles are kept in a cool place, so that samples of the first and second milkings can be mixed and pipetteful transferred to the Babcock test bottle before the milk has soured and thickened. If there is difficulty in keeping the samples from thickening, this can be entirely avoided by adding first to each sample bottle one small preservative tablet, which, dissolved in the milk, will prevent souring for a week or more.

Second Method — In this method no sampling dipper or sample bottles are needed. On the day that the milk is to be tested for fat, a 17.6 cc. pipette and a set of Babcock test bottles (one for each cow) are carried to the barn. A small box or tray with partitions is often used to prevent the bottles from tipping over. After weighing the milk as usual, it is stirred well and a sample is transferred from the pail with the 17.6 cc. pipette into a Babcock test bottle, which is labeled with the cow's number. As soon as convenient, these tests should be completed by adding acid, whirling, and reading the per cent of fat. It is also necessary to take a second sample of each cow's milk in the same way at the next milking time. The average of the tests of two consecutive milkings from any cow is used to represent the average per cent of fat in her milk for the month. If not enough test bottles are at hand to allow two bottles for each cow, the samples taken at the first milking should be whirled and read and the bottles emptied and washed in time to be used again at the second milking.

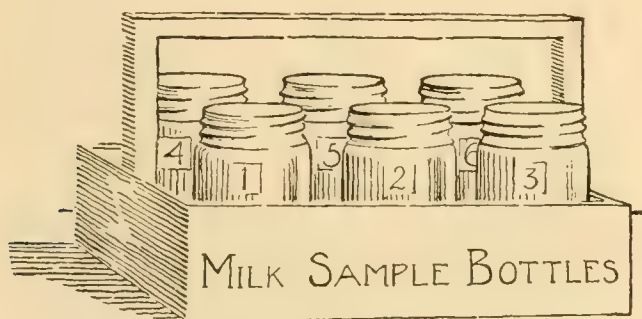

Fig. 14.—Convenient case for sample bottles.

Other Methods Sometimes Used—While the methods described above are sufficiently accurate for ordinary use, owners of exceptionally fine cows or those who have more time in which to do the testing may prefer to test more than one day's milk each month. For this purpose, preservative tablets are used, and the milk samples are added to the sample bottles for as many consecutive milkings as desired, usually covering two days, and in some cases three or four days. Since different milkings from the same cow vary in weight as well as in fat content, the method of collecting samples described above may be improved by purchasing and using a sampling tube instead of a sampling dipper. Where the sampling tube is used, the milk must be poured into a can having "straight-up" sides, and the sampling tube is then inserted to the bottom of the can. In this way, the volume of the sample taken from each milking is greater or smaller, in exact proportion to the amount of milk obtained from the cow. These and other precautions may be observed when a cow is being tested for the purpose of establishing a record. But when a herd is being tested by the owner to pick out the poorest

cows, in order that these may be sold and the herd improved, either the first or the second method described above will be found sufficiently accurate.

Testing Skim Milk by the Babcock Test—Wherever cream is sold, the skim milk should be tested occasionally to make sure that the cream separation is complete.

To test skim milk (1) collect the entire quantity of skim milk running from the separator in a tub or barrel, mix it well by stirring; (2) while

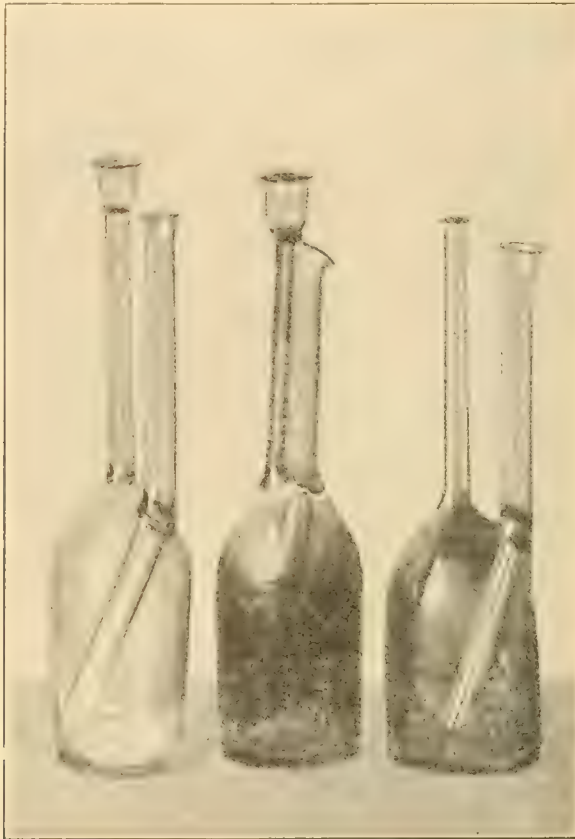

Fig. 15.—Test bottles used with skim milk and whey. Each division of the scale represents .05 per cent on the neck of the bottle at the right. On the two bottles at the left, each division represents .01 per cent fat.

Courtesy of the Wisconsin Experiment Station.

the skim milk is still in motion, measure with a pipette 17.6 cc. of milk, avoiding the foam, into a special form of Babcock test bottle called a skim milk bottle; (3) cool the milk to 60 degrees or lower, and (4) add acid and whirl at full speed for a few minutes longer than usual, and keep the bottles hot, since it is hard to get out all of the fat in testing skim milk.

The ordinary milk test bottle reading 10 per cent on the scale cannot be used for testing skim milk, because the column of fat from skim milk gen-

cally fills less than one division on the scale and therefore cannot be read. The skim milk test bottles, shown in Figure 15, have a double neck, with a wide tube for pouring in the milk and acid and a narrow tube in which the fat column rises. The scale reads up to one-fourth or one-half of one per cent.

These bottles are also used for testing buttermilk and whey. Only about three-fourths of a cylinder full of sulphuric acid should be added to each test bottle of whey. The test is then completed in the usual way.

TESTING CREAM ON THE FARM

Cream testing is more difficult than the testing of milk or skim milk, because in putting exactly 18 grams of cream into the test bottle, the cream cannot be measured with a pipette but must be weighed. There are three principal reasons for this. First, a pipette holding 18 grams of milk will hold 16 to 17 grams of cream, depending upon the richness. Second, much of the cream will stick to the inside of the pipette, which would make the

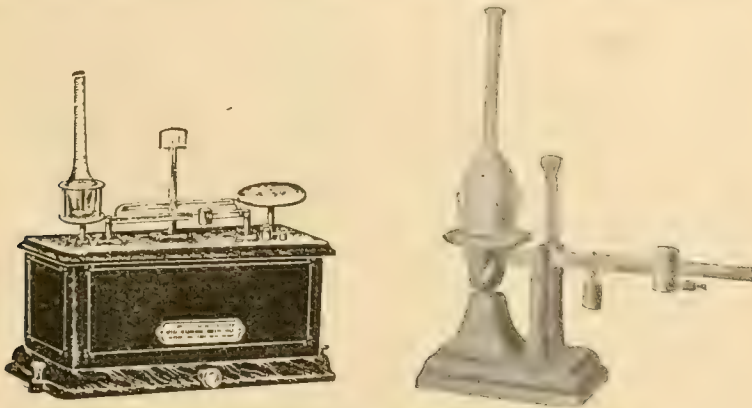

Fig. 16.—Scales for weighing samples of cream for the Babcock test should weigh accurately to .05 gram, or less.

test read entirely too low. Third, fresh separator cream contains many air bubbles.

Cream scales, accurate to one gram, and one or two nine-gram weights are needed for weighing cream samples into the test bottle. Several forms of scales are sold for this purpose. See Fig. 16.

Since cream may contain 20 to 45 per cent fat, a special form of cream test bottle, holding 18 grams of cream and reading up to 30, 40 or 50 per cent on the scale is used. See Figure 17.

Two cream test bottles are placed on opposite pans of the cream scales and the sliding weight is moved until the two sides are exactly balanced. Two nine-gram weights are then added to the right hand pan. The cream is thoroughly mixed by vigorously stirring, which must be continued longer than for sampling milk because cream is thicker and harder to mix. While the cream is still in motion, some of it is taken up in the pipette, and allowed

to flow into the cream bottle on the left hand pan of the scales without spilling, rapidly at first, and later by drops, until the scales are again exactly balanced. The bottle now contains exactly 18 grams of cream. The two nine-gram weights are then taken off and the second test bottle is filled until the scales are again balanced, from another pipette full of cream, taken from the can after stirring again. After mixing the acid and cream, the bottles are placed in the tester and whirled as usual.



Fig. 17.—Type of cream bottle which is widely used. The smallest graduation should be 0.5 per cent. The 6-inch bottles are most common, as the 9-inch sizes require a special centrifuge.

Courtesy of the Wisconsin Experiment Station

The per cent of fat in cream is read from the bottom of the fat column to the bottom of the upper meniscus. The test when read should be held at the level of the eye, which can be done more exactly, perhaps, with the aid of a mirror.

The fat should be at about 140 degrees F. when the reading is made and the bottles should always be set in hot water at this temperature for 15 minutes before making the final reading. The results of two tests on the same lot of cream should not differ more than .5 per cent.

If brown or black specks appear in the fat column so as to prevent correct

reading, the action of the sulphuric acid is too violent. To prevent this, see that neither the cream nor acid is too warm and either use a little less acid, or else as soon as the acid and cream have turned to the proper brown color in the test bottle, add water, up to the bottom of the neck, to dilute the acid and check its further action.

Instead of putting 18 grams of cream into the regular cream test bottle some operators use only nine grams in each bottle. To do this, one nine-gram weight instead of two is placed on the scale pan. The final reading is multiplied by two to get the per cent of fat in the cream. By this means cream containing 40 or 50 per cent fat can be tested in a cream test bottle graduated to only 30 per cent on the neck.

Nine-gram cream test bottles are also on the market with the scale on the neck so marked, that after weighing nine grams of cream into the bottle, the correct per cent of fat is read directly from the neck of the bottle. The reading is not multiplied by two. These bottles are distinguished by having "9 gram" engraved on the neck, near the top. Nine cc. of water and 17.5 cc. of acid are added to nine grams of cream in the test bottle.

The testing of cream should be attempted only by persons who are thoroughly familiar with the testing of milk by the Babcock test. Butter and cheese are sometimes tested for fat but these tests are much more difficult than the preceding and are seldom if ever made on the farm.

Reading Cream Tests—It may be somewhat difficult to see the bottom of the curve or meniscus at the top of the fat column in a cream test bottle. The meniscus can be flattened, and the reading made easier by placing on top of the fat column, just before reading, a few drops of glymol, amyl alcohol, or fat-saturated, 90 per cent grain alcohol (denatured.) The reading is best made immediately after the addition, before the bottles are shaken.

To prepare fat-saturated alcohol, add a small amount of butter to half a pint of alcohol in a small bottle. Shake well, and leave for a few hours. Some undissolved butter fat should always be present at the bottom of the bottle in order that the alcohol may become fully saturated. A dye may be used to color the alcohol red if desired. Glymol colored with alkanet is also widely used.

Testing the Accuracy of Babcock Test Bottles—Makers of Babcock test bottles are usually careful to get the marks on the neck in the right place, but sometimes bottles are found which are not correctly marked and these bottles give incorrect readings.

The correctness of the marks on the neck of a test bottle may be tested by weighing, or by means of a burette, or more quickly by the use of the Trowbridge calibrator. In using the burette, remember that the neck of the milk test bottle should hold exactly 2 cc. between the zero and the 10% mark, and an ordinary 30% cream test bottle should hold 6 cc. between the zero and the 30% mark.

The Trowbridge calibrator, shown in Figure 18, can be obtained in different sizes for milk bottles and for cream bottles.

To use the calibrator, fill the test bottle with water exactly to the lowest mark on the neck as shown in *B* in the figure. With a strip of cloth or blotting paper, remove any drops from the inside of the neck. Now push the calibrator into the neck until the top of the water stands half way between the brass plugs, as shown in *C*. The reading on the scale at the top of the water should then be just 5 per cent in the milk test bottle, if it is correctly marked. Push the second brass plug under the water, as in *D*, and read

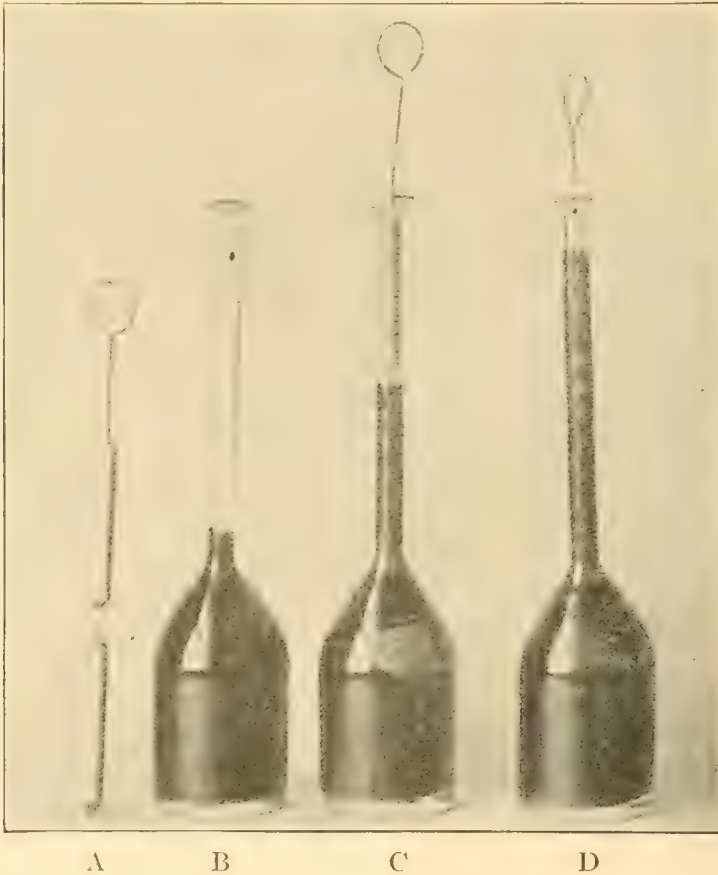

Fig. 18.—The Trowbridge calibrator is the most convenient device for testing the accuracy of test bottles on the farm. The water used can be colored if desired.

Courtesy of the Wisconsin Experiment Station

again. The reading should be just 10 per cent. If the scale does not read correctly to .1 per cent on a milk bottle or .5 per cent on a cream bottle, the bottle should not be used, but should be sent back to the dealer and exchanged. In calibrating, always read the bottom of the meniscus at the top of the water column.

In Wisconsin, the State Superintendent of Weights and Measures, at Madison, Wis., is authorized to test the accuracy of cream scales, milk

pipettes, and Babcock test bottles for milk and cream, etc., which are used in the state. Only those test bottles, scales, etc., which meet the state requirements as to mode of construction, and which bear the official seal, showing their accuracy, can be lawfully used, in Wisconsin, in the testing of milk or cream for sale. Dairymen and milk dealers should avail themselves of this opportunity to have their bottle calibrated free of charge, and when purchasing new test bottles should specify that they shall pass the inspection of the state authorities. Factory patrons should insist on the use of calibrated bottles, etc., in order to avoid errors in payments, through use of incorrect glassware.

How Composite Samples Are Made — Cream samples should be tested daily. At factories, there is not time to test each patron's milk every day. But if the milk were sampled and tested only on one or two days each month, it might happen on those days to be richer or poorer in fat than usual. To avoid such difficulty, factorymen generally provide a set of sample bottles, each marked with a patron's number and provided with a tight fitting stopper to prevent evaporation of contents. Every day a small portion of milk is taken from the weigh can with a sampling device and placed in each patron's bottle. The samples are kept from curdling by the addition of a small preservative tablet to each bottle, and the entire set of composite samples is tested at the end of two weeks.

THE OVERRUN

Many people do not know just what is meant by "overrun" in creameries and are often given the wrong idea of it by the man in charge of the creamery.

For illustration, let us take 100 pounds of milk, testing 5 per cent fat by the Babcock test. The butterfat from this 100 pounds of milk will be 5 pounds ($100 \times .05 = 5$ pounds). But this is not butter, as we are often led to believe. As a rule one pound of butterfat will make 1.2 pounds of butter, and 5 pounds of butterfat as in the illustration will yield 6 pounds of butter. This "increase of the churn over the test" is what is generally called "overrun," and will vary from 10 to 16 per cent; that is, if a quantity of milk contains exactly 100 pounds of butterfat, from 110 to 116 pounds of butter ready for market will be obtained from it. The overrun from cream will be somewhat larger, 18 to 22 per cent, but will never exceed 25 per cent, unless the butter contains less than 80 per cent fat.

Factors Influencing the Overrun from Milk — Even with the very best of care and attention to details, variations in the overrun will occur. The amount of butter that can be made from a given quantity of milk or cream will depend on four conditions: (1) The test of the milk or cream,—the higher the test the larger will be the overrun. (2) Losses of butter fat in the skim milk and the buttermilk will reduce the overrun. (3) The more water and salt that is incorporated in the butter the higher will be the over-

run, but quality of product should never be sacrificed in order to secure a large overrun. (4) Mechanical losses tend to reduce the overrun.

The grades of milk and cream probably influence the overrun more than any other single factor. Table No. 1 shows that with 2.5 per cent milk, there is a loss of 3.1 lbs. of fat in the skim milk, a loss of 1.2 lbs. of fat in the buttermilk, and of 3.0 lbs. in the creamery waste, for every 100 lbs. of fat in the whole milk, or a total loss of 7.6 lbs. from these sources. In case of 6 per cent milk these losses are 1.4 lbs., .5 lb. and 3.0 lbs. for skim milk, buttermilk and waste, respectively; a total loss of 4.9 lbs., or 2.7 lbs. less than the losses with poor milk.

TABLE No. 1.
FAT AVAILABLE FOR BUTTER IN DIFFERENT GRADES OF MILK

Grade of Milk	Whole milk	Skim milk	Butter milk	Waste	Total loss	Fat available for butter
						Per cent.
2.5 per cent.	4000 lbs. 2.5 per cent.	3400 lbs. .1 per cent.	400 lbs. .3 per cent.	Pounds	Pounds	
Fat	100 lbs.	3.4 lbs.	1.2 lbs.	3.0	7.6	92.4
3.5 per cent.	2857 lbs. 3.5 per cent.	2429 lbs. .1 per cent.	286 lbs. .3 per cent.			
Fat	100 lbs.	2.4 lbs.	.9 lb.	3.0	6.3	93.7
4.0 per cent.	2500 lbs. 4 per cent.	2125 lbs. .1 per cent.	250 lbs. .3 per cent.			
Fat	100 lbs.	2.1 lbs.	.7 lb.	3.0	5.8	94.2
6.0 per cent.	1666 $\frac{2}{3}$ lbs. 6 per cent.	1417 lbs. .1 per cent.	167 lbs. .3 per cent.			
Fat	100 lbs.	1.4 lbs.	.5 lb.	3.0	4.9	95.1

In the above table it is assumed that the skim milk tests 0.1 per cent fat and is 85 per cent of the whole milk, and that the buttermilk tests 0.3 per cent fat and forms 10 per cent of the whole milk.

The overrun from each of the four grades of milk can be calculated for butter containing a certain per cent of fat. Assuming the fat content of butter to be 83 per cent on the average, the quantity of butter obtained from the 100 lbs. of fat, or rather from the portion thereof which is available for butter, in each case will be as follows:

TABLE No. 2.

100 lbs. of fat from	Available fat	Butter cont. 83 per cent. fat	Overrun
	Pounds	Pounds	Per cent.
4,000 pounds of 2.5 per cent. milk.....	92.4	111.3	11.3
2,857 pounds of 3.5 per cent. milk.....	93.7	113.0	13.0
2,500 pounds of 4.0 per cent. milk.....	94.2	113.9	13.5
1,666 pounds of 6.0 per cent. milk.....	95.1	114.6	14.6

The overrun figures above may be increased by saving some of the three pounds of butter fat lost by waste. If it were possible to entirely eliminate this loss there would be three pounds more available fat in each case, viz., 95.4, 96.7, 97.2, 98.1 lbs. These amounts of fat will make 115,

116.5, 117.1, and 118.2 lbs. butter, corresponding to an overrun of 15, 16.5, 17.1, and 18.2 per cent from milk of the different fat contents mentioned.

Overrun from Cream — The overrun from cream is, as already stated, larger than from milk because there is no loss of fat in the skim milk to be considered. Rich cream will give a slightly larger overrun than thin cream, for the same reasons as have been shown in the calculations of overrun from milk of different fat contents. If similar calculations are made for cream of different richness as those given above for milk, the fat available for butter-making and the yield of butter per 100 pounds of fat in the cream will be as shown below. A mechanical loss in the process of butter-making amounting to 2 per cent has been assumed in these calculations.

TABLE No. 3.

100 lbs. fat in cream	Available fat	Butter of 83 per cent fat.	Overrun
Per cent.	Pounds	Pounds	Per cent
20	96.8	116.6	16.6
30	97.3	117.2	17.2
40	97.6	117.6	17.6

We note that the overrun for cream of different quality under the conditions given ranges from 16.6 for 20 per cent cream to 17.6 for 40 per cent cream. A somewhat larger overrun would be obtained when the butter made contains less fat and more water than assumed.

Use of Overrun Table — By means of table No. 4, the butter yield corresponding to overruns from 10 to 20 per cent may be ascertained. The total yield of butter is divided by the total number of pounds of fat delivered; the quotient will give the amount of butter made from one pound of fat, and this figure multiplied by the fat delivered by each patron shows the pounds of butter to be credited to each patron. To use the table, find in the upper horizontal line the number corresponding nearest to the number of pounds of butter from one pound of fat. The vertical column in which this falls gives the pounds of butter from 100 lbs. of milk containing the per cents of fat given in the outside columns (Babcock).

Butter — Cream is used for the manufacture of butter or for direct consumption. In the former case a certain amount of acidity is generally allowed to develop therein previous to the churning process. This secures a more complete churning and produces peculiar flavors in the butter, without which it would seem insipid to most people. Nearly all butter made in this country is salted before being placed on the market. Salt is a preservative and for a limited length of time prevents butter from spoiling. Unsalted butter made from sweet cream is a common food article in Southern and Middle Europe, but only an insignificant amount is manufactured and consumed in America; salted butter made in Europe also contains considerably less salt than American butter. Butter contains all the fat of the cream except a small portion which goes into the buttermilk, and a small unavoid-

able mechanical loss incident to the handling of the products. Butter should contain at least 80 per cent of fat and ordinarily contains about 83 per cent; besides this amount of fat, butter is generally composed of about 13 per cent water, 1 per cent curd and lactic acid, and 3 per cent salt.

TABLE No. 4.
OVERRUN TABLE, SHOWING POUNDS OF BUTTER FROM ONE HUNDRED
POUNDS OF MILK

Per cent. fat	Pounds Butter											Per cent. fat
	1.10	1.11	1.12	1.13	1.14	1.15	1.16	1.17	1.18	1.19	1.20	
Babcock Test												
3.0	3.30	3.33	3.36	3.39	3.42	3.45	3.48	3.51	3.54	3.57	3.60	3.0
3.1	3.41	3.44	3.47	3.50	3.53	3.57	3.60	3.63	3.66	3.68	3.72	3.1
3.2	3.52	3.55	3.58	3.62	3.65	3.68	3.71	3.74	3.78	3.81	3.84	3.2
3.3	3.63	3.66	3.70	3.73	3.76	3.80	3.83	3.86	3.89	3.93	3.96	3.3
3.4	3.74	3.77	3.81	3.84	3.88	3.91	3.94	3.98	4.01	4.05	4.08	3.4
3.5	3.85	3.89	3.92	3.96	3.99	4.03	4.06	4.10	4.13	4.17	4.20	3.5
3.6	3.96	4.00	4.03	4.07	4.10	4.14	4.18	4.21	4.25	4.28	4.32	3.6
3.7	4.07	4.11	4.14	4.18	4.22	4.26	4.29	4.33	4.37	4.40	4.44	3.7
3.8	4.18	4.22	4.26	4.29	4.33	4.37	4.41	4.45	4.48	4.52	4.56	3.8
3.9	4.29	4.33	4.37	4.41	4.45	4.49	4.52	4.56	4.60	4.64	4.68	3.9
4.0	4.40	4.44	4.48	4.52	4.56	4.60	4.64	4.68	4.72	4.76	4.80	4.0
4.1	4.51	4.55	4.59	4.63	4.67	4.72	4.76	4.80	4.84	4.88	4.92	4.1
4.2	4.62	4.66	4.70	4.75	4.79	4.83	4.87	4.91	4.96	5.00	5.04	4.2
4.3	4.73	4.77	4.82	4.86	4.90	4.95	4.99	5.03	5.07	5.12	5.16	4.3
4.4	4.84	4.88	4.93	4.97	5.02	5.06	5.10	5.15	5.19	5.24	5.28	4.4
4.5	4.95	5.00	5.04	5.09	5.13	5.18	5.22	5.27	5.31	5.36	5.40	4.5
4.6	5.06	5.11	5.15	5.20	5.24	5.29	5.34	5.38	5.43	5.47	5.52	4.6
4.7	5.17	5.22	5.26	5.31	5.36	5.41	5.45	5.49	5.55	5.59	5.64	4.7
4.8	5.28	5.33	5.38	5.42	5.47	5.52	5.57	5.62	5.66	5.71	5.76	4.8
4.9	5.39	5.44	5.49	5.54	5.59	5.64	5.68	5.73	5.78	5.83	5.88	4.9
5.0	5.50	5.55	5.60	5.65	5.70	5.75	5.80	5.85	5.90	5.95	6.00	5.0
5.1	5.61	5.66	5.71	5.76	5.81	5.87	5.92	5.97	6.02	6.07	6.12	5.1
5.2	5.72	5.77	5.82	5.88	5.93	5.98	6.03	6.08	6.14	6.19	6.24	5.2
5.3	5.83	5.88	5.94	5.99	6.04	6.10	6.15	6.20	6.25	6.31	6.36	5.3
5.4	5.94	5.99	6.05	6.10	6.16	6.21	6.26	6.32	6.37	6.43	6.48	5.4
5.5	6.05	6.11	6.16	6.22	6.27	6.33	6.38	6.44	6.49	6.55	6.60	5.5
5.6	6.16	6.22	6.27	6.33	6.38	6.44	6.50	6.55	6.61	6.66	6.72	5.6
5.7	6.27	6.33	6.38	6.44	6.50	6.56	6.61	6.67	6.73	6.78	6.84	5.7
5.8	6.38	6.44	6.50	6.55	6.61	6.67	6.73	6.79	6.84	6.90	6.96	5.8
5.9	6.49	6.55	6.61	6.67	6.73	6.79	6.84	6.90	6.96	7.02	7.08	5.9
6.0	6.60	6.66	6.72	6.78	6.84	6.90	6.96	7.02	7.08	7.14	7.20	6.0

Buttermilk has a composition similar to skim milk, but varies much more than this product, according to the acidity, temperature, and thickness of the cream, and other churning factors. It contains about 9 per cent. of solids, viz., milk sugar (and lactic acid) 4 per cent, casein and albumen 4 per cent, fat .3 per cent, and ash .7 per cent.

The quantity of butter and by-products obtained in the manufacture of butter are as follows: 1,000 lbs. of milk of average quality will give about 850 lbs. of skim milk and 145 lbs. of cream (separator slime and mechanical loss, 5 lbs.); this amount of cream will make about 42 lbs. of butter and 100 lbs. of buttermilk (mechanical loss, 3 lbs.).

Cheese—In the manufacture of American cheddar cheese, whole milk is heated about 86° F., and a small amount of rennet extract is added, which coagulates the casein; the albumen of the milk is not precipitated by rennet and remains in solution. "Green" cheese, as taken from the press, is made up, roughly speaking, of 37 per cent of water, 31 per cent of fat,

24 per cent of albuminoids (nearly all casein), and about 5 per cent of milk sugar, lactic acid, and ash (largely salt). In the curing of cheese there is some loss from drying, but the main changes occur in the breaking up of the firm curd into soluble and digestible nitrogenous compounds, peptones, amids, etc.

Whey is the by-product obtained in the manufacture of cheese. It consists of water and less than 1 per cent of solids; of the latter about 5 per cent is milk sugar, .8 per cent albumen, .6 per cent ash, and .3 per cent fat. Whey is generally used for feeding farm animals; it is the raw material from which milk sugar and whey cheese are made.

Condensed Milk—This is manufactured from whole milk or from partially skimmed milk. In many brands a large quantity of sugar (25 per cent or more) is added to the condensed milk in the process of manufacture so as to secure perfect keeping quality in the product. Brands to which no sugar has been added are also on the market, and with such brands the relation between the various solid constituents of the condensed milk will be essentially the same as that between the constituents of milk solids. Condensed milk should contain at least 1 per cent fat, and must be free from preservatives and other foreign substances (except sugar.)

CALCULATING DIVIDENDS BY THE FAT TEST

The Babcock test is now quite generally used at American cheese factories and creameries where it has replaced the old and very unjust "pooling system" of paying for milk and cream. To calculate the amount of money to be paid each patron at a co-operative factory it is first necessary to add the receipts from all sales made during the month, and subtract from this sum the running expenses, including supplies, labor, etc., as for example:

Total sales, month of June, 19—.....	\$2,101.23
Total expenses, month of June, 19—.....	175.00

Proceeds to be divided among patrons.....	\$1,926.23
---	------------

This amount of money, \$1,926.23, is to be divided among the patrons in proportion to the weight of butter fat delivered by each. To calculate how much money each man should receive, it is necessary first to add up the columns on the factory milk sheet shown in Figure 19 to find out how many pounds of milk each patron delivered during the first and second halves of the month. At most factories composite samples of the milk delivered by each patron are tested twice a month. From the record of weights and tests upon the milk sheet for patron No. 1, it is seen that between June 1 and 14 he delivered 3,123 pounds of milk, testing 4.2 per cent fat, which contained 131.2 pounds of fat. Between June 15 and 30 he delivered 3,010 pounds of milk testing 4.1 per cent fat or 123.4 pounds of fat, making a total of 254.6 pounds of fat during the month. In a similar way can be found the weight of fat delivered by each of the ten patrons during the month. Add these all together to find the total weight of butter fat delivered at the factory as follows:

Patron's number	Pounds fat delivered
1	254.6
2	567.5
3	
4	
5	
6	
7	
8	
9	
10	
Total pounds fat	8,175.4

FACTORY MILK SHEET, MONETA FACTORY, JUNE, 19—.

Patron's No.	1	2	3	4	5	6	7	8	9	10
Date June, 19—.	Lbs. Milk	Lbs. Milk	Lbs. Milk	Lbs. Milk	Lbs. Milk	Lbs. Milk	Lbs. Milk	Lbs. Milk	Lbs. Milk	Lbs. Milk
1	215	420	130	557	698	986	1548	317	811	1400
2	210	425	124	543	687	980	1537	324	820	1393
3	216	419	139	569	700	975	1530	333	831	1380
4	210	427	127	557	682	983	1559	325	815	1410
5	213	410	120	550	674	989	1545	328	827	1390
6	215	425	128	561	683	995	1560	329	809	1427
7	221	435	137	569	690	1018	1572	330	819	1438
8	232	430	130	574	698	992	1558	337	831	1395
9	236	428	133	565	680	987	1568	330	837	1396
10	223	420	137	563	703	985	1580	324	822	1358
11	222	431	146	579	694	989	1589	338	814	1400
12	245	435	140	570	687	996	1576	345	809	1430
13	236	439	150	583	675	990	1589	350	828	1411
14	229	447	143	580	684	1019	1580	337	835	1436
Total Milk	3123									
Test %	4.2	4.4	3.8	4.1	3.7	3.6	3.5	3.2	3.8	3.9
Lbs. Fat	131.2									
15	220	450	153	585	695	1007	1575	350	840	1470
16	215	445	159	597	693	995	1587	347	851	1462
17	206	453	152	580	704	990	1596	358	838	1497
18	197	462	147	583	711	999	1584	363	847	1460
19	190	465	158	590	715	1011	1598	355	859	1475
20	180	460	150	599	698	1015	1580	347	850	1483
21	180	455	141	587	700	992	1603	359	862	1479
22	175	465	158	580	715	989	1592	363	852	1470
23	180	469	162	593	704	996	1610	354	845	1465
24	172	473	168	585	719	990	1619	359	858	1475
25	181	462	158	579	711	998	1597	352	849	1480
26	189	475	167	570	730	986	1618	348	851	1473
27	182	467	154	578	725	979	1595	340	857	1481
28	180	453	169	585	739	984	1589	346	846	1490
29	178	478	153	592	747	996	1611	341	853	1470
30	185	488	160	597	732	1010	1620	350	870	1486
Total Milk	3010									
Test %	4.1	4.1	3.7	4.3	3.9	3.8	3.6	3.3	3.5	3.6
Lbs. Fat	123.4									
Total fat for month.	254.6									

Figure 19.—The factory milk sheet at the end of the month, showing the total fat delivered by patron No. 1. The reader should complete the calculation for the other nine patrons.

Dividing the proceeds, \$1,926.23, by the total number of pounds of fat delivered, 8,175.4, gives the price to be paid the patrons for each pound of butter fat delivered, which in this case is \$.2356.

The amount of money due each patron is found by multiplying the number of pounds of fat each delivered, by the price of butter fat, in this case \$.2356, as shown below.

Patron's number	Pounds fat delivered	Price per pound for butterfat	Amount due the patrons
1.....	254 6	Multiplied by \$0.2356	\$59 98
2.....	567 5	Multiplied by \$0.2356
3.....	Multiplied by \$0.2356
4.....	Multiplied by \$0.2356
5.....	Multiplied by \$0.2356
6.....	Multiplied by \$0.2356
7.....	Multiplied by \$0.2356
8.....	Multiplied by \$0.2356
9.....	Multiplied by \$0.2356
10.....	Multiplied by \$0.2356
Total.....	8,175 4	Total	\$1,926 11

The patrons are entitled to the amounts given in the last column, and there remain also 12 cents undivided which amount is carried over to the following month, as cash on hand.

PROBLEMS IN CALCULATING MILK AND CREAM TESTS

1. On the neck of a test bottle, the top of the fat column stood at 7.7 and the bottom at 3.5. What per cent of fat was present?
2. If a cow gave 4,280 pounds of milk in a year, with an average test 4.2 per cent fat, how many pounds of fat did she produce?
3. One cow in a herd gave in the morning 20 pounds of milk testing 3.7 per cent and at night 17 pounds testing 3.5 per cent. What was the total weight of the butter fat for that day? What was the average per cent. of butter fat for the day?
4. Another cow in the same herd gave 28 pounds of milk in the morning testing 3.6 per cent and 21 pounds testing 3.8 per cent in the evening. What weight of butter fat did the cow produce on that day?
5. If the two cows ate the same amount of feed, which is the more profitable?
6. The milk was sold for 20 cents per pound of butter fat. How much money did each cow bring in?
7. The next day the two cows gave the same amounts of milk and butter fat as on the previous day but the farmer ran the milk through the separator and sold the cream for 80 cents. How many cents did each cow bring in?
8. The skim milk from a hand separator which was out of order tested .20 per cent and there were on the average, 800 pounds of skim milk each day for a month. How many pounds of butter fat did the skim milk contain during the month?
9. After repairing the separator, the test was found to be only .05 per

cent on the average. How many pounds of butter fat did the skim milk contain that month?

10. How much butter fat was saved in a month by repairing the separator? How much in a year? If butter fat sold for 15 cents a pound the year around, how much money would be saved in a year?

11. One hundred pounds of milk, testing 4 per cent fat was run through a separator, and the cream weighed 12.5 pounds. The skim milk contained .05 per cent fat. Can you figure out how much the skim milk weighed, and what per cent of fat the cream contained?

12. At the Moneta factory, the patrons asked the secretary to figure out how much difference there would be in each patron's pay check, if payments were based on the weight of milk delivered, (the pooling system) instead of on the weight of fat delivered (payment by the test). Can you do this, using the figures given in Figure 19?

CHAPTER IX

DRESSING AND CURING MEAT

- I. SELECTION OF ANIMALS. II. CARE BEFORE KILLING—TOOLS NECESSARY. III. KILLING AND DRESSING HOGS. IV. CUTTING UP HOGS—DRESSED HOGS FOR MARKET. V. KILLING AND DRESSING CATTLE. VI. CUTTING UP BEEF—HOW TO CARRY A QUARTER. VII. KILLING AND DRESSING VEAL—DRESSED VEAL FOR MARKET. VIII. DRESSING SHEEP—CUTTING MUTTON. IX. KILLING AND DRESSING POULTRY—DRESSED POULTRY FOR MARKET. X. CURING MEAT—RECIPES. XI. SMOKING MEAT. XII. RENDERING LARD. XIII. SAUSAGE. XIV. FRESH MEAT—BEEF CLUBS.

The farmer, of all men, should have the best and most abundant supply of fresh meats for his table. All the ancient traditions of rural plenty are connected in some way with the meat supply, from the savory meal with which Rebekah beguiled Isaac, to the "fatted calf" of the Prodigal Son. Yet today we see such a perverted condition of affairs that in many farm homes the supply of meat for most of the year consists of salt pork and an occasional fowl. Much of the salt pork is of poor quality for lack of skill in slaughtering and curing.

A better supply of meat will do much to improve the farmer's bill of fare, and a well-supplied table does much to better and brighten the life of the farmstead.

The purpose of this Chapter is to show the farmer how he may supply his family, and perhaps his neighbors, with meat which would command the highest prices in the market. To do this he must know how to handle the animal that has been selected for slaughter. In addition to this he must follow a few simple rules in regard to slaughtering, and curing the meat. Home slaughtering promotes neighborhood co-operation in the distribution of the meat supply, and so presents an additional incentive for its more general adoption.

SELECTION OF ANIMALS

The first consideration in selecting an animal to be slaughtered for food is that it should be entirely healthy. No matter how good the outward appearance, or how fat the animal may be, it is impossible to secure good meat from an animal that is diseased. Besides, there is always danger that the disease may be transmitted to those who eat the meat. During the early stages of some animal diseases the danger is small, but it is difficult for anyone but a veterinarian to decide when the limit of safety has been passed. Better avoid every animal infected with tuberculosis, lumpy jaw, hog cholera, or any disease accompanied by fever. Fever always deranges

the system and impairs the wholesomeness and keeping qualities of the meat. "A healthy animal or none" is the best rule to follow.

Condition—Next to healthfulness, it is desirable that any animal selected for slaughter should be in good condition. Lean, scrawny animals, that have become thin from inferior feeding or care, will give little satisfaction when served up on the table. When losing flesh, the fibers of the muscles shrink, and the meat becomes tough and unpalatable. Such animals can usually be fattened, and the presence of a certain amount of fat will greatly improve the flavor, tenderness, and appearance of the carcass. It is here, by the way, that the breeding of animals plays an important part. Long continued care and selection, with good feeding, are sure to produce desirable carcasses.

Age—To yield the best meat, an animal should be neither too old nor too young. The meat from an old animal is usually tough; that from one too young lacks flavor and substance, owing to the large amount of water present. An old animal, in poor flesh, will make a fairly good carcass if fattened rapidly.

With some variation in the breeds, the best age for slaughtering cattle is from 18 to 36 months. Calves should not be slaughtered until about six weeks old; and the veal is much better if they are fed until eight or ten weeks old.

Hogs may be slaughtered at any age after two months; but the pork is better if from a well-fed animal from six to ten months old.

Sheep may be slaughtered when two months old; but to be desirable at that age they should be especially fed as milk lambs. The most desirable mutton comes from sheep from eight months to two years old. When over two years old, the meat is likely to be tough and lean, or if fat to carry too much waste.

Care Before Killing—Any animal should remain unfed for from twenty-four to thirty hours before killing. The object is to clear the system of food and to facilitate bleeding, as food left in the stomach will decompose rapidly after slaughtering and generate gases which are likely to taint the meat. The animals should be given all the water they will drink, as this will aid in clearing the system of food and make it easier to drain off the blood.

Never bruise or whip an animal just before killing. Not only does this tend to excite him, but it causes the clotting of blood under the skin. The mark disfigures the carcass after the hide has been removed. Pulling the wool of a sheep when alive will also result in a badly bruised carcass. An excited animal never makes a good carcass. Its temperature is usually two or three degrees above normal. It is difficult to remove this surplus heat and the meat will often spoil in a very short time.

Injured Animals—If an animal has a limb broken, or is otherwise badly hurt, it may be safely used for food provided it is bled at once. Unless this is done, fever resulting from infection of the injured tissues will spoil the meat, making it gluey and stringy.

Tools Necessary — It is false economy to attempt to do butchering without the few simple, necessary tools and apparatus. These are: a killing-ax or hammer; a 6-inch skinning-knife; a 12-inch steel; a 26 or 28-inch meat-saw; a hog-hook; a pritch for bracing beeves while skinning; a 6-inch sticking-knife; a few wooden gambrels; a candlestick scraper; a 14-inch steak knife; a block and tackle for raising the carcasses of heavy beeves; a small rack for hogs and sheep; a table for scalding hogs; and a barrel or tank for scalding water. The total cost of all need not exceed \$10. With such an outfit a person can do practically all kinds of farm butchering.

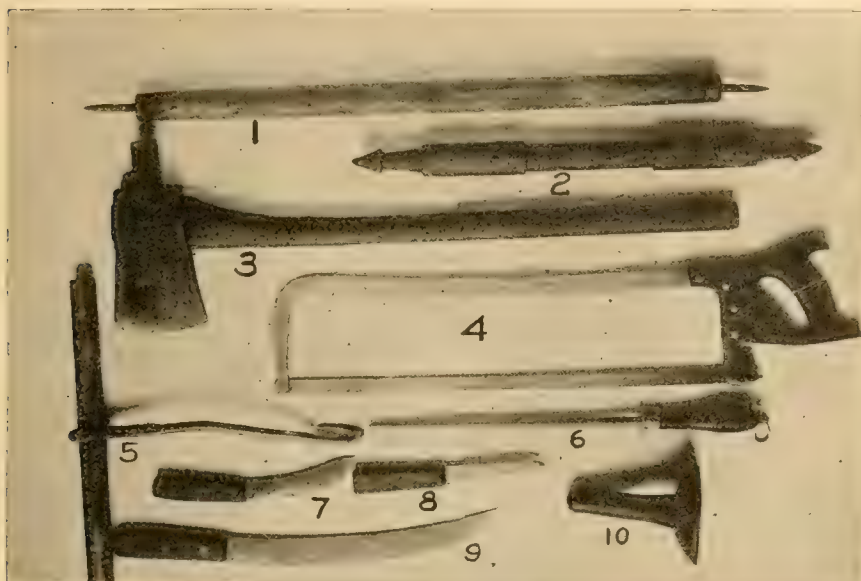

FIG. 1.—SET OF BUTCHER TOOLS

- | | | |
|---------------|-------------------|-------------------------|
| 1. Pritch | 4. Saw | 8. Sticking Knife |
| 2. Gambrel | 5. Hog Hook | 9. Steak Knife |
| 3. Killing Ax | 6. Steel | 10. Candlestick Scraper |
| | 7. Skinning Knife | |

Courtesy of the Minnesota Experiment Station

KILLING AND DRESSING HOGS

Be sure that everything needed is placed in readiness before beginning. Be careful at every step.

In handling the hog, put a quarter-inch rope around one of the hind legs or back of the tusks in the upper jaw. Either method is good, and if the rope is well adjusted there is no danger of the hog getting away. The best position for the hog, while sticking, is square on the back. Two men should reach under and grasp the legs on the opposite side, and with a quick jerk throw the hog over and roll it onto its back. Then it can easily be held in place by one man, who places one leg on each side, just back of the shoulder pits of the hog, holding the front feet with his hands, while his companion does the sticking, as shown in Fig. 2.

Where the hog is too large to handle in this way, it may be stunned by a blow from an ax, or by shooting. A 22 calibre rifle, which is found on almost every farm, is powerful enough to drop a hog of any size if it is in the hands of a good marksman. There need be no danger to the men in thus dropping the hog; it avoids fooling around with ropes; and the hog holds still while it is being stuck. Stunning with an ax is more disagreeable and it crushes in more skull. The gunman should crouch down so as to have the bullet penetrate the brain; if it does not the hog will squeal and it will be very difficult to get him to hold still while another shot is taken.

Sticking — A straight, narrow-bladed knife, about six inches long,



FIG 2.—STICKING A HOG

- | | |
|----------------------|-------------------------------|
| A. Breastbone | C. Path of knife |
| B. Slit made in skin | D. Main blood vessels severed |
| | E. Heart |

Note the proper angle at which to start the knife and that the knife does not go near the heart. It is neither necessary nor desirable to cut the heart. It should be entirely uninjured so that it can pump the blood out through the severed blood vessels.

Courtesy of the Minnesota Experiment Station

is most desirable for sticking. When the hog is on the ground, as shown in the cut, with the sticking-knife shave off the hair just in front of the breastbone for a distance of four or five inches. Thrust the knife in from 3 to 4 inches in front of the breastbone, directing it at an angle of between 30 and 45 degrees, directly over the midline and toward the root of the tail. Cut down toward the backbone, but not too far back, lest the knife enter the heart cavity; in which case the animal will die instantly, and the blood will not be properly drained from the body. The knife should be steadily kept on the midline, to avoid making an opening back of the ribs, in which the blood may settle. The purpose in sticking is to sever the arteries as they

come from the heart, outside of the chest cavity, and spread to enter the shoulders, thus draining the blood from the system. If the blood is desired for blood sausage the hog is turned upon its side, and the blood caught in a dish, with about a tablespoonful of salt in it. The blood must be stirred continuously, and after it has cooled somewhat, it is strained through a colander. The hog should never lie with its rear quarters lower than its front quarters or they may remain bloody. The hog should never be moved before it is dead or the parts that rub on the ground will be discolored.

If help is insufficient or the hog too large, it may be hoisted by means of pulleys, and stuck and bled while hanging.

Scalding—Unless the hog is too large, it is most conveniently scalded in a barrel, as it requires less hot water than a tank. Place the barrel at an angle of 45 degrees at the end of a table or platform two or two and one-half feet high, so that the top of the barrel will be even with the table. An inverted wagon box will do as a substitute for the table, but it is not good for the wagon box.

Hogs weighing above 225 pounds are best handled in scalding by using a block and tackle with four or five strands of rope, and an automatic clutch. The barrel can be set up straight, thus making the use of more water possible. This makes it certain that the front and rear scaldings will come together in the middle.

The only requirements are a block and tackle with a sound rope and a place to fasten it. Accidents will be reduced by the use of this plan. The tackle is applied by hooking a hook into the lower jaw bone, and for the front scalding in the rear hook. Never scald the hog before it is dead or it will be red.

Where the scalding is to be done out of doors, in cold weather, it is best to have the water at the boiling point. By the time it is removed from the kettle to the barrel, it will be at very nearly the right temperature for scalding, which is 185 degrees Fahrenheit.

If no thermometer is at hand, test the temperature by putting the finger in the water three times in rapid succession. If it burns quite severely the third time, the water is about right. Usually it will be necessary to add about half a pailful of cold water if the water was boiling. The water should be boiling before the hog is killed and then the hog should be near the barrel before the water is out into it.

To aid the scalding and help remove the scurf, it is well to add an alkali of some kind to the water. Soft soap or concentrated lye is best; but hardwood ashes will do. If soap is used, take a small handful to about thirty gallons of water; if lye, a teaspoonful; and if ashes, a small shovelful.

Stir the water well. Put the hoghook through the lower jaw, place the hog on the table, and slide it into the barrel, rear end first. The reason for this is that, if the water is temporarily too hot and the hair should "set" in scalding, it is easier to remove it by shaving from the rear than from the fore part of the animal.

To guard against scalding, lower the hog slowly into the barrel with the tackle and immediately pull it up again for a few seconds. Keep the body moving in the water, so that no part will rest too long against the side of the barrel.

Test the stage of scalding by pulling the body far enough out of the water to try the hair, and give it a little chance to air, which will hasten the scalding process. When the hair begins to come off easily, pull the body out upon the table. Cover the barrel with an old blanket, especially if the weather is cold, to keep the water hot.

Remove the hair and scurf on the legs and feet at once, by twisting them in both hands. Remove the dewclaws at the same time. Then, with the candlestick scraper or any convenient tool, take off as much of the hair and scurf as possible from the scalded rear part of the body.

Now loosen the tendons in the hind legs, and insert the gambrel, or put the hook through the hock joint of one leg, and scald the front part. In loosening the tendons to insert the gambrel, take care that both tendons on each leg are loosened. If only the upper one is loosened, the hog may fall after it is hung up, as this tendon alone is not strong enough to carry the weight. Because the water is not now so hot, it will take a little longer to scald the fore part. The hog should be kept in motion in the water.

If there should be unscalded patches on the hog, cover them up with hair and pour boiling water over it for a short time. This will loosen the hair so that it need not be shaved off.

Scraping—When a test shows that the hair comes off readily, again pull the body out upon the table. Scrape the head, ears, and feet first, as they are harder to clean and will retain the heat a shorter time than the other parts of the body. Hair and scurf having been mostly removed, pour hot water over the body; begin at one end, and shave off whatever hair is left.

Removing Entrails—The hog is now ready to be hung up, as the most convenient position for the removal of the internal organs. A handy place on a tree or the side of a building will suffice, so long as there is room to work. Fig. 3 shows a ladder being used.

After the hog is hung up, a pailful of water should be poured over the body, and the carcass scraped with the sharp edge of the knife at right angles to remove any remnants of dirt. It is well to open the hog's jaws and stick in a corncob. This separates the teeth, and thus makes sawing the head into pieces easier.

To remove the entrails, cut through the midline, beginning at the top, and cutting down to the head. Loosen the rectum by cutting around on each side and pulling it out between the pelvic bones.

Place the knife between the first and second fingers of the left hand, inserting the fingers where the opening has been made, and with the right hand force the knife down to the breastbone. Be careful that the knife does not stick through between the fingers. In this way, the fingers will serve

as a protection to the intestines and a guide in making the cut. After this opening has been made, remove the omentum or fat which surrounds the stomach. Then remove the intestines and stomach, cutting the gullet as soon as it is drawn up far enough. The gullet may be pulled out without cutting it off.

Next loosen the tongue by cutting on each side of it, just inside of the jawbone and pulling it out with an upward jerk. Then cut through the breastbone, beginning at the front end and cutting upward slightly to one side. Now remove the pluck—the heart, lungs, œsophagus, and windpipe—by cutting the diaphragm. This is the membrane which separates the organs of the chest from the stomach, bowels, and other abdominal organs. Cut just between the light and dark areas of the diaphragm. Cut down along the backbone, and it will be easy to pull out the entire pluck, together with the tongue. Pour some cold water through the chest cavity, to cleanse it of all foreign matter and blood.

The Leaf Lard—It is well to remove the leaf lard or kidney fat while the carcass is still warm, as this facilitates cooling the carcass, and lessens the danger of the hams and loin souring. The leaf lard should be spread out on a table to cool, with the outer surface, on which there is a thin membrane, down. When weather is cool it is as well to remove the leaf lard after cooling. It is then easily taken out by starting it at the front and stripping it out. Splitting the carcass through the middle while still warm further insures thorough cooling, and makes it easier to handle. If this is not done, take a stick about 18 inches long and spread the sides, so as to allow a free circulation of air. The splitting is more easily done when the carcass is cooled, and, if the weather is cool enough, it is probably best to wait. In splitting the carcass with saw or cleaver be careful to cut as near the midline as possible. A saw is preferred, except for an expert.



FIG. 3.—OPENING A HOG

Note that the knife is held in the right hand while the point is covered by the fingers of the left hand to prevent cutting the intestines.

Courtesy of the Minnesota Experiment Station

CUTTING UP HOGS

Pork carcasses should not be cut up until well cooled. Much pork is

spoiled in curing from lack of proper cooling in the carcass. The carcass is usually divided into four parts—head, shoulder, middle and hams.

The Head—The head is readily removed by cutting through the flesh surrounding the atlas joint with a knife, making the cut about an inch back of the ear and twisting the head off. This is most easily done when the hog is hanging. The head may be used for sausage or for making head-cheese. The jowl is very acceptable for use in baking beans.

The Shoulder—The shoulder is cut so as to include the first four or even five ribs.

After its removal from the middle, remove from the shoulder the ribs and that part of the backbone to which they are attached. These are the "spare ribs." In cutting them out, all the meat possible should be left on the shoulder, which should then be trimmed for curing.

In case only a small amount of cured meat is desired, the top of the shoulder, called the butt, may be removed, cutting at about one-third the distance from the top, parallel with the top line. The fat on the shoulder butt may be used for lard, and the lean portions for steaks or roasts. Trim off all rough edges on the shoulder, and use the trimmings for sausage.

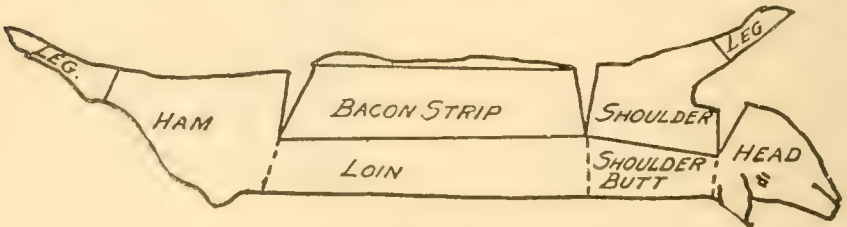

Fig. 4.—Showing Cuts of Meat in a Side of Pork.

If left, they will be wasted. All meat that is to go into the brine should be trimmed smooth. Remove the foot about an inch above the knee joint.

The Middle—In cutting the middle from the ham, make the cut just back of the rise in the backbone, and at an angle of about 45 degrees, cutting toward the root of the tail. Much loin meat is thus saved which would otherwise be trimmed off the ham for sausage. The middle is divided into loin, fat-back, spare ribs and bacon strip. The loin and fat back are cut off in one piece. The cut is made parallel to the backbone, and just below the tenderloin muscle on the rear part of the middle. Remove the fat on the top of the loin, being careful not to cut into the lean meat. The loin is used for chops or roasts, and the fat-back for lard.

Next remove the ribs from the bacon strip, cutting close, so as to leave as much lean meat as possible on the bacon piece, as it is one of the most highly prized parts of the carcass. It may be left entire or cut in two pieces. Before trimming the edges, take some flat instrument and flatten the sides by pounding. Then trim all edges square and smooth.

The Hams—Trim from the hams all rough and scraggy edges, but expose as little of the lean meat as possible, because the brine will harden it.

One should always try not to leave a cut muscle exposed but to have some fat or membrane on the outer surface. Cut off the leg about an inch above the joint.

Dressed Hogs for Market—When the hogs are dressed for the local market, it is very necessary to get them cleaned well. They should not be hauled to town before they are well cooled, and then they should be carefully protected from dirt with a clean white cloth. The liver usually accompanies the dressed carcass.

KILLING AND DRESSING CATTLE

Have all necessary tools ready at hand. Secure the animal with a three-quarters-inch rope, passed around its neck, with a slipknot over the nose, high enough not to choke the animal. Tie this rope to a tree, to a ring in



Fig. 5.—Proper method of Sticking a Beef.

Courtesy of the Minnesota Experiment Station

the corner of the barn, or to anything that is strong enough to hold the animal until it is stunned.

Stunning—The animal may be stunned with a killing-ax, a heavy hammer, or shot with a rifle. Draw an imaginary line from the base of each horn across to the eye on the opposite side, and place blow or bullet where these two lines intersect. A true aim is more necessary than a very heavy blow.

Bleeding—As soon as the animal is down, loosen the rope and stand squarely in front of the animal. Place one foot in front of the fore legs forcing them back, and with the other foot below the head, draw back so that the skin over the brisket and neck is stretched tight. With the skinning-

knife in the right hand, make a long incision from the tip of the brisket to well toward the head. Cut in deeply, so that the windpipe is exposed. Then feel for the tip of the breastbone; insert the knife at this point and push it straight toward the backbone, at right angles with it, on either side of the windpipe, being careful, however, not to cut back into the chest cavity. In this way you will sever the arteries and veins just where they cross, coming from the heart, outside of the chest cavity, and the blood will flow out very rapidly. Care should always be taken not to puncture the pleura, or thin membrane which lines the chest cavity, allowing the blood to flow into the chest cavity, and causing a blood-stained carcass.

Skinning – Begin skinning at the head. Make a long slit from the horns or the top of the poll to the nose, and skin the forehead and cheek of the side of the head that is up. Turn the head on the poll and skin the other cheek down as far as the ears and poll. As soon as the skin is removed on both sides as far as practicable, and over the back of the poll, remove the head, cutting across the “Adam’s apple,” or enlarged portion of the windpipe. Cut the muscle on either side, and sever the spinal cord at the atlas joint. The head will come off very easily, and there is no necessity for using an ax to cut the joint.

When the head is removed, take out the tongue before it gets cold. This is done by cutting on each side, immediately within the jawbone, loosening it at the tip and cutting back far enough so as to include all the meat around the base. Loosen the front part and pull it out backwards. Scrape it clean in cold water, working the knife against the sharp projections on the surface. When cool, lay it out flat, or hang it up by the tip.

The next step is to put the animal square on its back. Brace it by means of a block or a pritch. If a pritch is used, run the sharp end in the side as near the back of the fore leg as possible, because, if it is inserted too far back, it will leave a hole in the hide, which will decrease its value. Begin by skinning the front legs, cutting straight across the leg at the knee joint, just where it begins to enlarge. There are two joints at this place; one is known as the straight joint, and the other as a rough joint. Be sure that the cut is made across the straight joint, because if the irregular joint is cut it gives the front shank a poor appearance. Cut in deeply enough so as to cut the leg nearly off. Hold the knife firmly in the hand, skin down each side well past the dewclaws, remove the leg at the joint that has been opened, and pull it out backwards. After both front legs have been finished in this manner, nothing further is done to them until the carcass has been hung up.

Pass from the front to the hind legs, and put one leg between your knees and draw it well forward. Cut across the tendons at any place between the dewclaws and the hock, so as to straighten out the foot. Then, with the knife flat, split the skin over the hock and back over

the round, being careful not to cut into the lean muscle, making the opening to just back of the cod. Then skin out both sides of the hock and the sides of the leg. Skin down only far enough to expose the hock joint; cut across the enlargement of the joint and remove the leg at the straight joint. This will be a little more difficult than the joint on the fore leg, because it is a little harder to locate. Before the leg is removed, make the opening in the hock for the beef-tree by which the carcass is to be drawn up. Remove the other leg in the same manner, meeting the cut from the opposite side just back of the cod.

Open the skin by a long cut through the middle, from the brisket to the tail. Begin skinning on the side of the brisket down to the fore legs and down on the side as far as possible. While skinning, always keep the knife flat on the side of the hide and keep the hide drawn tight. Skin back to the round. Skin both sides, being careful at all times not to cut through the thin membrane which covers the outside of the carcass. Also keep the outside of the hide from coming in contact with the skinned surface. Keep at hand a cloth wrung out of hot water, so that any bloodstains may be removed or soiled parts cleaned.

While the animal is on its back, it is well to open the abdominal cavity for the removal of the intestines and other internal organs. Free the windpipe and gullet at the front end; then make a cut just to the rear of the breastbone, deep enough to open the abdominal cavity. With the knife in the right hand and the blade outward, insert the hand and make the cut from the breastbone to the cod, letting the hand serve as protection against cutting the intestines or paunch. Remove the caul fat which covers the paunch, and pull out the intestines to one side, so as to make room for the saw in splitting the pelvic bones; and also saw through the breastbone, being careful at all times to cut as near in the center as possible. While the carcass is in this position, cut around and loosen the rectum; also loosen the pluck in the chest cavity. Do not attempt to remove the paunch and intestines until the carcass has been raised.

In raising the carcass, a block and tackle, a hayfork, a rope and windlass, or anything that is convenient for hoisting a carcass, may be used. A beef tree especially made for raising beeves or a common two-horse evener, may be used to put through the hocks to spread the hind quarters. Raise the rear of the carcass about four feet from the ground, and resume the skinning.

Rumping — Skin out the tail by lifting a strip of skin from the root to the tip on the lower side. Skin out a trifle on each side, unjoint the tail from the body at the end joint, grasp it here with a dry cloth, and pull it free from the hide. Skin down over the rump, and back as far as possible. As soon as this is completed, the carcass should be raised a little higher, and the paunch and intestines removed. Be careful not

to loosen or remove the kidney fat. Split the carcass down to the loin, and then raise it so that it will just clear the floor. Split the hide from a point which was on the center of the brisket to the elbow, and over the back of the fore leg. Skin down the neck and on each side of the leg, skinning the sides and back by taking long, deep cuts from the hip bones clear down and over the shoulder. This is an easy way to remove the hide over the loin and ribs. Leave the hide attached



FIG. 6.—REMOVING THE ENTRAILS
Note the proper height for convenience in removing the paunch and intestines. The proper method of removing the hide from the round and back is also shown. The head has been cut off.

Courtesy of the Minnesota Experiment Station

at the round and hocks. This will carry the weight of the hide and facilitate skinning below. Skin out the round by stripping the hide off, beginning with the leg. This can be done without a knife if care is taken in getting the right start, and not breaking the thin membrane which covers the flesh.

Removing the Pluck—Remove the pluck by cutting the diaphragm, or membrane between the chest and abdomen, cutting just outside of the layer of muscle which holds it in place.

As soon as the hide has been removed, take a hot, damp cloth and remove all particles of foreign matter or blood that may be on the inside or outside of the carcass.

Splitting the Carcass—The carcass may be split with a saw, or by an adept, with a cleaver. Expose the backbone on the inside, by parting the kidneys and cutting through the fat and other tissues that might hide it on the inside.

Be careful, however, not to cut on either side, as to do so will expose the muscles on either side of the vertebræ.

Do not bear down on the saw, but let its natural weight do the work. Saw from the outside of the carcass. After cutting through about five of the vertebræ, that portion of the backbone will spread and make the

sawing easier. Be careful, however, that the spinous processes or projections from the backbone are split in the center all the way down. After splitting past the loin, these spinous processes become very long, and special care must be taken not to cut on either side.

Cut all scraggy ends from the inside of the shoulder and throat, and work both front legs up and down, so as to remove all blood that may have settled in the veins and arteries that were cut while sticking the beef.

Cooling—Cooling practically completes the operation until the carcass is taken to the cutting-room. It should be cooled as rapidly as possible; though care should be taken not to freeze the outer surface too rapidly, as it is likely to sour the meat round the bone and the thick portions, because of not giving the heat a chance to escape. Care should also be taken to keep flies away while meat is cooling.

Saving the Hide—Lay the hide flat upon the floor and spread out all the parts. In warm weather, put a heavy layer of salt on the inside,

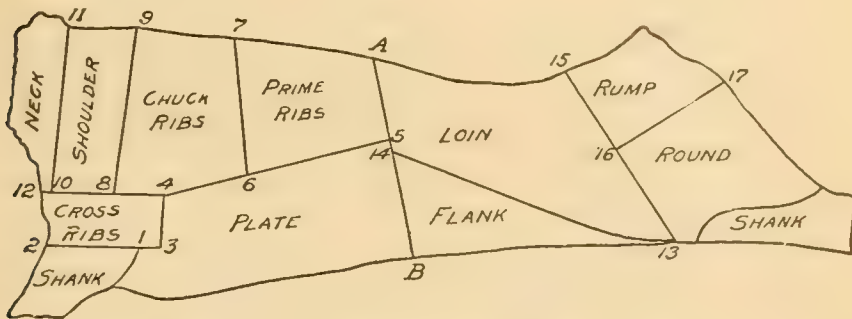

Fig. 7.—Side of Beef, Showing the Various Cuts.

evenly covering all parts. To fold the hide for storing or shipping, throw all the scraggy ends on the inside. Then fold it into a strip eighteen inches wide, and roll it up, beginning at the front part. Roll it tightly, leaving the tail on the outside of the hide. Tie it securely with a stout twine or small rope, so that it will not come open in handling or while it is being shipped.

CUTTING UP A BEEF

Having been halved while being dressed, beef carcasses are quartered before being put on the block. The front quarter is cut from the hind quarter between the twelfth and thirteenth ribs, counting from the front. This leaves one rib on the hind quarter. Care should be exercised in making this cut, so as to have it smooth and straight. Locate the exact place between the two ribs on the inside of the carcass, inserting the knife and cutting towards the backbone, keeping the knife in the middle. Turn the knife and cut out through the flank up to within

two or three inches of the outside. This part should be left uncut until the backbone has been sawed.

A wooden block or table of some kind should be provided on which to cut the meat. The front quarter should be thrown on the table with the outside of the carcass up. Fig. 7 shows the proper divisions to make in cutting a carcass of beef. They should be made in the order named below.

Front Quarter

Shank — Remove by cutting through the joint from 1 to 2. To prepare for cooking, cut into three or four pieces. It is used for stews and soup.

Plate — Remove by cutting from a point (5) about 12 or 14 inches from backbone, to 4, between the second and third ribs, to 3, to 2. Cut into small squares about four inches in size. It is used for stews, boiling meat, corned beef, and hamburger steak.

Cross-Ribs — Cut from 4 to 12. This cut is used for boiling and pot roasting.

Prime Ribs — Remove by cutting between the fifth and sixth ribs from 6 to 7. This cut includes seven ribs. To prepare for an oven roast, cut into three pieces, remove the bone on the back, also the tendon along the outer edge, and cut across the ribs with a saw. It may have all the bones removed, and be rolled up in a tight mass called a rolled roast.

Chuck Ribs — Cut from 8 to 9, removing all the ribs left in the front quarter. Cut into small pieces, to be used for boiling or pot-roasting.

Shoulder — Cut from 10 to 11, remove all scraggy ends, and cut into small pieces so that it may be used for boiling, or corning.

Neck — Trim off all bloody portions and cut the meat from the bone, to be used for hamburger steak or mincemeat.

Hind Quarter

Flank — Cut from 13 to 14, leaving about a four-inch piece of rib in the flank. Trim off the fat and connective tissue, and use for boiling meat or hamburger steak.

Loin — Cut from the rise in the spinal column over the rump 15 to 13. Begin to cut steaks from the large end, which will be sirloin until the small part of the loin is reached. The portion with the T-shaped bone and muscles, on both sides is the porterhouse steak. Steaks from the loin should vary from a half inch to an inch in thickness.

Rump — Cut from 16 to 17, parallel to the pelvic bone. Cut into convenient sizes to be used for oven roasts or boiling.

Round — Cut round steak from the thick portion, and use the lower portion for boiling. The round may also be used for corned beef or oven roasts and for making dried beef.

All pieces of meat should be properly trimmed, and all bloody and soiled portions removed before sending to the kitchen.

How to Carry a Quarter — As soon as the fore quarter is well placed on the shoulder of the person who is to carry it to the block the small strip by which it hangs is cut, and by taking a step forward just as the cut is made, the quarter will drop on the carrier's shoulder in good shape. To carry a quarter of beef properly, place the forearm of the carcass in the front of the shoulder, so that the weight will be squarely on top of the shoulder.

KILLING AND DRESSING VEAL

Calves should be killed for veal when about six to eight weeks old. Most states have laws stating what the age of calves must be before they can be sold. Some also have a minimum weight limit. Raise the calf by its hind legs, by means of a block and tackle or hoist of some kind. With a small hammer stun the animal, and stick in front of the brisket, as in sticking a beef.

Skinning — As soon as the blood is all removed, skin the head. Begin by skinning over the sides of the jaw and the lower part of the throat, and sever the head at the atlas joint. Next remove the hide over the lower part of the shank, as in the case of a beef. Be careful not to skin any part of the forearm.

Skin the hind legs by cutting across the hock-joint just where it begins to enlarge, or at what is known as the straight joint. Then remove the hide on the lower portion of the shank, and remove as in the case of beef. Make an opening through the hide and through the hock, in which the gambrel is put while finishing the carcass. This is all the skinning that is done in dressing a veal calf for market.

Removing the Entrails — Make an opening through the crotch and the midline, cutting down as far as the breast-bone, at the same time loosening the rectum from the upper side. Loosen the windpipe and gullet in the brisket. This is all the opening that should be made, remove the paunch, intestines, and gall sac, but be careful not to remove the liver, as this must always be left in a veal carcass for market. Take out the pluck by loosening the diaphragm and cutting down the backbone, drawing the pluck up through the opening made through the midline.

Take a hot, damp cloth, and wipe any soiled portion on the inside; also clean and trim off any scraggy or bloody portions around the neck. This completes the dressing.

For home consumption, the calf may be skinned while it is warm. The indications of a good veal calf are a brushy tail, compact form, and thick flesh, well covered with fat that is white and brittle. In cutting veal, practically the same plan is followed as in the case of beef.

Dressed Veal for Market — Calves are usually sold alive from dairy

farms at the age of about three weeks. It does not pay to keep them until they are eight weeks old, the proper age for farm slaughtering. But if they are slaughtered on the farm for shipment, they are not skinned.

DRESSING SHEEP

Select a dry place in which to do the work; because, if the wool is wet, it is almost impossible to get a clean carcass. It is well to have a small table on which the sheep may be placed for sticking; although it may be done on



Fig. 8.—Proper Method of Sticking a Sheep.

Courtesy of the Minnesota Experiment Station

the ground or on some dry straw. Care must be taken that the wool does not come in contact with the blood.

Throwing and Sticking — In catching a sheep, with one hand grasp it by the neck, and with the other by the root of the tail, the flank, or by a hind foot. Never catch it by the wool; as it will always produce a bruised spot, which detracts from the appearance of the carcass. Throw the animal on the left side, either by catching the left hind foot and pushing the sheep over to the left, or by drawing the left hind foot under the sheep toward the front end. Hold it thus by placing the knee on the sheep's right shoulder.

Place the left hand over the mouth, and draw the head back. With a

straight sticking-knife, cut just back of the jawbone. Cut close to the vertebrae, pushing the knife through to the opposite side; and cut outward through the windpipe; which, at the same time, will sever the arteries. Put the knife aside; place the right hand on top of the head, and with a quick jerk force the head over backward; which will break the spinal column. If the spinal cord is not broken by thus dislocating the Atlas joint, cut it with the knife. Be careful that no blood gets on the front legs and fleece.

Skinning — The knife should be used in skinning only about the legs and throat and tail; everywhere else, resort to fisting. Do not commence skinning until bleeding has entirely ceased. Then first remove the skin over the lower side of the head, and remove the tongue. Then place the left front foot between the knees, roll the sheep on its back, and begin skinning the front quarter; holding the knife flat and cutting a strip of wool from the toes, over the front of the leg toward the neck, leaving a triangular piece of hide over the front of the brisket. Hold the knife flat all the time, so as not to cut the thin lining on the outside of the carcass. Repeat the operation on the right fore leg.

Then take the left hind leg between the knees, and cut over the back of the leg and hock, as in skinning the front leg; but be careful not to cut the tendons by which the carcass is to be hung up later on. Carry this opening back to just below the tail. Make a similar-cut on the right leg. By making the opening in this way, a triangular piece of hide is left between the hind legs and over the cod, which will make it easier to remove the pelt later on. Skin out on each side of the hock; loosen the tendons on the back of the leg, and cut off the toes at the joint between the dewclaws and the toes.

Fisting — Henceforward the process of removing the pelt is mainly carried on by fisting. Be sure the hands are clean and dry. Have a pail of hot water at hand, in which to wash them whenever soiled; thus keeping the carcass perfectly clean.

Place the foot over the lower part of the head, and grasp the wedge-shaped piece of hide left in front of the brisket. Draw this backward over the brisket, and then, with the folded hand, work around under the pelt on each side of the brisket and shoulder; being careful to leave the thin membrane covering the carcass. Fist over the belly and sides as far back as the hind legs. Always work with the knuckles toward the hide. Next, fist over the hind quarter, removing the wedge-shaped piece of hide by working along the midline until the opening, which was made in front, is reached; and also fist toward each side over the leg. Then take a piece of stout cord and tie the two hind legs together by the tendons.

Hang the carcass on a rack or hook, high enough for the head to clear the floor. With a knife remove the fore feet, cutting across the enlargement of the joint just above the toes. Split the pelt through the midline, and let it drop back over the carcass; being careful that no wool touches the carcass so as to stain it. Fist back over the sides, and work up over the hind legs, on over the loin and shoulders, to very near the backbone. In fisting over

the hind legs, be sure to work up; for, if this is not done, the thin membrane which covers the leg is likely to be broken, thus causing difficulty in keeping the carcass.

While the knife is being used in removing the pelt around the tail, loosen the rectum by cutting around it on all sides. Then grasp the pelt at the top, and pull it down over the backbone, stripping it down to the base of the head. Remove the head by cutting through the Atlas joint. Wring a cloth out of hot water, and remove any particles of blood or dirt on the outside of the carcass.

Removing Viscera—Insert a knife in front of the brisket, cutting a slit down alongside of and loosening the windpipe. Then insert the knife just in front of the cod or pelvic bone, and split through the membrane to the breast-bone.

In the case of lambs or yearling sheep, remove the caul-fat which surrounds the paunch, and put it in the hide to keep it warm. Then remove the intestines, paunch and liver. As soon as these are taken out, remove the

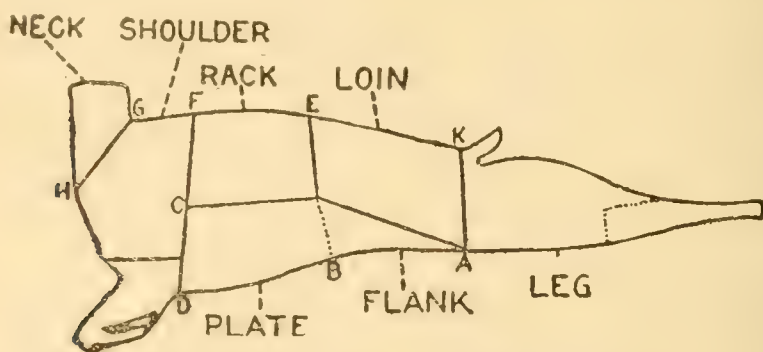

Fig. 9.—Side of Mutton, Showing Various Cuts.

pluck by cutting around the membrane which holds it in place, between the two cavities, and cutting downward at the backbone. Pull the pluck out through the opening made to remove the paunch and intestines. With a hot, damp cloth, remove any blood or dirt that may be inside the cavity, but do not use too much water. Wipe the outside also, wherever bloody or soiled. Then take the caul fat and put it around the hind legs.

Cutting Mutton—First split the carcass into halves, then cut off the flank and breast, following the line A B C D (Fig. 9). Cut off the leg at the top of the round, A to K, just touching the hip joint. Remove the shank below the fleshy part of the leg. Cut off the shoulder between the third and fourth ribs and the neck at the shoulder vein. Remove the front shank at the elbow joint. Where a "saddle of mutton" is wanted, one must deviate from this method of cutting and cut the saddle in one piece before the carcass is split into halves. The leg of mutton is sometimes cut into steak, but is usually roasted whole or boiled. The loin may be used for chops, the slices being cut parallel to the ribs, or it may be roasted if desired.

The chops should be cut "one rib" thick. If used as an oven roast the joints in the backbone should be cracked with a cleaver to admit of easy carving at the table. The rack is used in the same way as the loin. The joints in the back of the shoulder should be cracked and the ribs broken across the middle on the inside, when it may be used as an oven roast from a young mutton, or as a boiling piece if from an old one. The breast and flank when trimmed are used for stews; the neck and shank, for soup stock.

KILLING AND DRESSING POULTRY

Poultry for use in the farm home is dressed in small quantities and kept only a few days at the most, hence circumstances will dictate largely the methods to be followed.

Where only one or two chickens are to be dressed there is no quicker or surer way of bleeding than the old-fashioned one of chopping off the head. If to be used in a day or two they should be scalded at once and picked. If they are plunged into a pail of very cold water as soon as picked the heat will be taken out of the skin and the bird will keep without the skin drying so much. The crop and intestines should be removed as soon as the skin is cooled, though if they are empty no harm will come from leaving them undrawn until the fowl is wanted for use.

Turkeys, geese, and ducks may be treated in the same way, though they are usually bled and dry picked. In dry picking turkeys, as soon as the feathers droop, showing that collapse has begun, picking should begin with the bird suspended from a hook. It is important that it be done rapidly so as to complete the work before the feathers set. Grasping only a few feathers between the finger and thumb, pull upward and backward. Leave the bird hanging until cool in order that the blood may settle to the head.

With ducks and geese, owing to the thickness of the feathers, dry picking is a slower process than with other fowls. After bleeding, place a board across an open barrel that is clean. Wrap a cloth around the head of the fowl to catch the blood. Lay the goose or duck on the board, and with thumb and finger strip the feathers into the barrel. When the feathers have been removed the down may be singed off with a gasoline or alcohol flame. A hot flame should not be used as it will give an oily appearance to the skin.

Where it is not important to save the feathers quicker work may be done by scalding the fowls and wrapping them in a sack or blanket to steam for a few minutes; since there is a little danger of their being steamed too much, they should be closely watched. The feathers may then be removed as above described, and the birds cooled and singed. Chickens may be killed by dislocating their necks instead of bleeding them. This is a cleaner way and is claimed to preserve the meat better during shipment.

Dressed Poultry for Market—The fowls should fast about 18 hours before killing. Hang them up by their feet, open their beak, take a sharp thin-bladed knife and pass it up into the roof of the mouth, dividing the membrane. This kills them quickly and they bleed freely, and there is no

ugly cut in the skin. The fowl will bleed better if the neck is cut, and, if it is intended to remove the head anyhow, it is better to cut the throat. All fowls for market should be picked dry when still warm without tearing the bird's skin. Chickens and turkeys should be hung by the feet and ducks and geese by the head. Ducks and geese must never be scalded. As soon as the chickens are plucked, cut off their heads, draw the loose skin of the neck forward over the stump and tie it, remove the entrails and hang them up to cool. Fowls must never be put on sale undrawn, but the gizzard, heart, and liver should be packed inside each fowl.

The bodies of geese and ducks should never be singed to remove down, for this makes the skin oily and unsightly.

The fowls should be thoroughly cooled before packing, but never allowed to freeze. They should be chilled and packed tightly in boxes so that they cannot shake about.

CURING MEAT

Selection—Meat that is to be cured should always be thoroughly cooled and cut into convenient sizes before it is put into the brine or packed in dry salt. The pieces most commonly used for this purpose are the ham, shoulder, and bacon pieces from pork; and the cheaper cuts, such as the plate, shoulder, and chuck ribs, of beef. Mutton is very seldom cured and preserved. All the pieces that are to go through the curing process should be well trimmed, so as to leave no ragged edges or scraggy ends, as these portions will become dry and practically be wasted.

Methods—The two methods of curing meat that are commonly used are the brine process and dry-curing. Brine-cured meats are probably the best for farm use, for several reasons. In the first place, on most farms it is impossible to secure a desirable place in which to dry-cure. It is also less trouble handle the meat when brine-cured, as the only attention that it requires is to prepare properly and pack the meat in the vessel and prepare the brine for it, while the dry-curing method requires considerable time to rub and salt the meat at different times.

Preparing the Meat—It is highly essential that all animal heat shall be removed from the meat before an attempt is made to prepare it for curing. If salt comes in contact with the surface of the meat before all the animal heat is removed, it will have a tendency to shrink the muscles and form a coating on the outside which will not allow the generating gases to escape. Meat should never be frozen when salted, as the frost will prevent the proper penetration of the brine, and uneven curing will result.

Vessels—A round vessel of some kind is preferred for curing meat. It is easier to pack the meat in tightly, and better use can be made of the space. A clean hardwood barrel is best, either new, or one that has held molasses or syrup. A whiskey or vinegar barrel may be used, but in each case it should be well burned on the inside before it is used. A stone jar

may be used, but as a rule such jars are too expensive and too hard to handle, and there is danger of breaking them.

Preservatives—The preservatives that are most commonly used for curing meat are salt, saltpeter, and sugar or molasses. They are really the only ones necessary for perfect curing, although a number of other ingredients, such as boracic acid, borax, and soda, are quite frequently used for special purposes. Salt is astringent in its effect and has a tendency to make the muscle tissues hard and dry. Sugar or molasses, on the other hand, have a tendency to keep the muscle soft, besides adding a sweet and desirable flavor to the meat. Saltpeter is also an astringent and has a tendency to preserve the natural color of meat. Baking soda is often used merely for sweetening the brine and to keep it from spoiling.

Preparation of the Brine—Brine for 100 pounds of pork is made as follows:

10 lbs. salt	2 oz. granulated saltpeter
2 lbs. granulated sugar	4 gals. water

Dissolve the sugar, salt, and saltpeter in boiling water, or if possible, boil the brine for some time and let it cool thoroughly before pouring on the meat. Corn cobs are sometimes boiled in the water for 20 minutes, the water strained, and used in the making of the brine. The cobs give the artificial maple taste which some people desire.

The meat which is to be cured is washed and packed firmly in the barrel, with the skin side down, excepting the top layer which is to be laid with the skin up. Then weight down the meat with a clean rock. Keep the barrel in a cool, dark, well-ventilated place. Watch the brine and keep the foam skimmed off. If it becomes ropy or stringy, it should be boiled or new brine added, after washing the meat thoroughly. This meat should be repacked every ten days, putting the pieces that were on the bottom at the top of the barrel for the following ten days. This is essential, as the ingredients in the brine will settle, causing the brine to be stronger at the bottom of the barrel than at the top. Allow bacon to remain in the brine from 25 to 30 days and hams from 50 to 60 days, depending upon the thickness of the pieces. When cured, take the meat out and let it soak in fresh water from 4 to 6 hours, then hang up and let drip for 24 hours.

Recipes—We include at this point a number of recipes for which we wish to give credit to Professor Andrew Boss, of the University of Minnesota, College of Agriculture.

Corned Beef—The pieces commonly used for corning are the plate, rump, cross-ribs, and brisket; or, in other words the cheaper cuts of meat. The pieces should be cut to convenient sizes, say five or six inches square. Cut them all to about the same thickness, so that they will make an even layer in the barrel. Allow ten pounds of salt to each hundred pounds of meat. Sprinkle a layer of salt one-quarter of an inch in depth over the bottom of the barrel; pack in as closely as possible the cuts of meat, making

a layer five or six inches in thickness; then put on a layer of salt, following that with another layer of meat. Repeat until the meat and salt have all been packed in the barrel, care being used to reserve salt enough for a good layer on the top. After it has stood over night, add, for every 100 pounds of meat four pounds of sugar, two ounces of baking-soda, and four ounces of saltpeter, dissolved in a gallon of boiling water. Cool, and add three gallons more of water, which should be sufficient to cover this quantity of meat. A loose board cover, weighted down with a heavy stone or piece of iron, should be put on the meat to keep all of it under the brine. In case any should project, mould would start and the brine would spoil in a short time.

If the meat has been corned during the winter, and is to be kept until summer, it would be well to watch the brine closely during the spring, as it is more likely to spoil then than at any other season. If the brine appears to be ropy, or does not drip freely from the finger, it should be poured off and new brine added, after carefully washing the meat. The sugar or molasses in the brine has a tendency to ferment; and, unless the brine is kept in a cool place, there is sometimes trouble from that source. To secure thorough corning, the meat should be kept in the brine from twenty to thirty days.

Plain Salt Pork — Rub each piece of meat with fine common salt, and pack closely in a barrel. Let stand over night. The next day weigh out ten pounds of salt and two ounces of saltpeter for each 100 pounds of meat, and dissolve in four gallons of boiling water. Pour this brine, when cold, over the meat, cover, and weight the meat down to keep it under the brine. The pork should be kept in the brine until used.

Sugar-Cured Hams and Bacon — When the meat is cooled, rub each piece with salt and allow it to drain over night. Then pack it in a barrel, with the hams and shoulders in the bottom, using the strips of bacon to fill in between or to put on top. Weigh out eight pounds of salt, two of brown sugar, and two ounces of saltpeter for each 100 pounds of meat. Dissolve all in four gallons of boiling water, and after cooling cover the meat with it. Bacon strips should remain in the brine from four to six weeks; and hams from six to eight.

Dried Beef — Dried beef is one of the best lunch meats. The following formula for brine is a good one.

9 lbs. common salt	3 oz. saltpeter
2 lbs. granulated sugar	4 or 5 gallons cold water

The meat is salted for 24 hours, then washed and put in the brine. It should be turned every 6 to 10 days and the brine thoroughly stirred. The meat should remain in the brine for 50 or 60 days. Hang up to dry for a day or so and then put into the smokehouse and smoke for 3 days. A good plan is to smoke on alternate days, finishing on the fifth day. Keep the temperature about 80-90 degrees F., a little hotter than for hams and bacon. Store the same as hams and bacon.

SMOKING MEATS

Pickled and cured meats are smoked to aid in their preservation and to give flavor and palatability. The creosote formed by the combustion of the wood closes the pores to some extent, excludes the air, and is objectionable to insects.

House and Fuel—The smokehouse should be eight or ten feet high to give the best results, and of a size suited to the amount of meat likely to be smoked. Ample ventilation should be provided to carry off the warm air in order to prevent overheating the meat. Small openings under the eaves, or a chimney in the roof, will be sufficient, if so arranged as to be easily controlled. A firepot outside of the house proper, with a flue through which the smoke may be conducted to the meat chamber, gives the best conditions for smoking, when this cannot well be arranged, a fire may be built on the floor of the house. The construction should be such as to allow the smoke to pass up freely over the meat and out of the house.

Brick or stone houses are best, though the first cost is greater than if they are built of lumber. Large drygoods boxes, and even barrels, may be made to serve as smokehouses where only small amounts of meat are to be smoked. The care of the meat in such substitutes is so much more difficult, and the results so much less satisfactory, that a permanent place should be provided if possible.

The best fuel for smoking meats is maple wood, smothered with sawdust of the same material. Hard wood of any kind is preferable to soft wood. Resinous woods should never be used, as they are likely to impart disagreeable flavors to the product. Corncobs are the best substitutes for hard wood, and may be used if desired.

Filling the House—Meat that is to be smoked should be removed from the brine a day before being put into the smokehouse. If it has been cured in a strong brine, it will be best to soak the pieces in cold water over night, to prevent a crust of salt from forming on the outside when it is drained. The pieces should be hung up to drain, then hung in the smokehouse. All meat should be suspended below the ventilators, and should hang so that no two pieces come in contact, as this would prevent uniform smoking.

Firing—A slow fire may then be started, to warm up the meat gradually. During the winter months, in cold climates, it is best to keep the fire going continually until the smoking is complete, holding the temperature at about the same point. If the fire is allowed to die down, the meat becomes cold and the smoke does not penetrate readily. This results in too much smoking on the outside and very little on the inner portions of the meat. During the spring months and in the summer, a light fire may be started every second or third day for two weeks; the meat being allowed to hang in the smokehouse until sufficiently colored. When the fire is kept going steadily and an even temperature is maintained, from twenty-four to thirty-six hours will be required to finish one lot of meat. Smoke will not penetrate

frozen meat, and it will be necessary to extract all the frost from it before smoking such meat. In summer the house should be kept dark at all times, to prevent flies from entering. As soon as smoked sufficiently, the meat should be cooled by opening the ventilators or doors. When hard and firm, it may be canvased or packed away for summer use.

Keeping Smoked Meats — During moderate weather, smoked meat may be left in the smokehouse for some time. The house should be kept perfectly dark, and well enough ventilated to prevent dampness. A dry, cool cellar or attic, with free circulation, will be a satisfactory place for smoked meats at all seasons, if it is kept dark and the flies are excluded.

If to be kept only a short time, hams and bacon will need only to be hung out separately, without covering. For longer keeping, it will be necessary to wrap them first in waxed paper and then in burlap, canvas, or muslin, and to hang them in a cool, airy place, the object being to maintain a uniform temperature and to keep away insects.

RENDERING LARD

Only the best of fat should be used for choice lard. Leaf fat is the best. The back strip of the side also makes nice lard, as do the ham, shoulder, and neck trimmings. Gut fat should never be mixed with leaf and back fat. It makes a stronger flavored lard, and should be kept separate. All scraps of lean meat should be cut out of the fat before trying out, as they are very likely to stick to the kettle and get scorched, giving an unpleasant flavor to the lard. When preparing the fat for rendering, cut it into pieces from one to one and a half inches square. They should be nearly equal in size, so that they will render in about the same time. Fill a clean kettle about three-fourths full. Keep the kettle over a moderate fire until the cracklings are brown, and light enough to float. Frequent stirring will be necessary to prevent burning. When done, remove from the stove and allow to cool slightly, and then strain through a muslin cloth into a large jar. Stir it occasionally until it is cool enough to solidify. If pails or smaller jars are to be filled, the lard should be dipped out while just warm enough to be liquid. Stirring while the lard is cooling tends to whiten it and make it smoother. A quarter of a pound of saleratus added to each 100 pounds of fat has a like effect.

SAUSAGE

Pork sausage should be made only from clean, fresh pork. With each three pounds of lean pork use one pound of fat. As the parts usually used for sausage are the shoulder, neck, and lean trimmings, the sausage is quite likely to be too fat unless part of the fat is removed and used for lard. Mix the fat and lean meat together in chopping. If a rotary cutter is used, it is best to cut the meat twice. After it is cut the first time, spread it out thin and season. One ounce of pure, fine salt, one-half ounce of ground black pepper, and one-half ounce of pure leaf sage,

rubbed fine, to each four pounds of meat, will suit the taste of most persons. The seasoning should be sprinkled thinly over the cut meat, and the meat again run through the cutter, to mix the seasoning thoroughly. This method will give a more even mixing of the spices than can be obtained by working with the hands. For immediate use, the sausage may be packed away in stone jars or crocks, to be sliced for frying. Many people stuff it into casings made from the small intestines of the hog. When this is done, the intestines must be turned inside out and carefully cleaned.

There are many different methods of making sausage but that of the best quality is made from clean pork trimmings and a little water, although four parts of pork and one of beef make a very good mixture especially if seasoned as follows:

40 lbs. pork	3 oz. pepper
10 lbs. beef	5 oz. sage
1 lb. salt	5 lbs. water

To this formula may be added bread, boiled potatoes, or boiled rice, but these will make the sausage hard to keep because they sour quickly. Before frying the bulk pork sausage, mix about four eggs, thoroughly with each three pounds of meat. When frying never stick a fork into the meat but turn it over or take it out with a knife or spoon. A hole in the casing means the loss of a great deal of the flavor because the juices escape. Always cook pork of any kind until it is thoroughly done to kill trichina and other parasites which are injurious to man.

Breakfast Sausage — Breakfast sausage is made by adding to the pork sausage formula, three pounds of liver, two pounds of heart, and some bread. Use dry bread soaked in cold water but squeeze out the water before adding it to the meat. Otherwise it is made the same as pork sausage and stuffed into sheep casings.

Hamburg Steak — Often when steak is tough or when it looks as though it is rather dry it can be turned into Hamburg steak and with the proper seasoning can be made very juicy. This sausage is made by grinding clear beef trimmings with some beef suet and mixing as follows:

25 lbs. beef	2 oz. pepper
½ lb. salt	4 lbs. water

The meat is first ground through the coarse plate, spread out on a table or bench and seasoned, and then ground through the fine plate. Then add the water and mix as you would bread dough until it sticks together and will not crumb. Onions are added if desired but these are added when the sausage is used as the sausage would otherwise sour and become dark in color.

Liver Sausage — Liver sausage is one of the common domestic sausages. It was originally used among the Germans but now its use has become more general. It may be made in accordance with the following recipe:

35 lbs. pork trimmings (heads, shanks, etc.)	
15 lbs. lean veal or beef	1 lb. salt
7 lbs. liver	1 oz. allspice
7 lbs. dry bread	10 lbs. soup
2 oz. sweet marjoram	Garlic or onions if desired

First cook the pork and veal or beef for two or three hours, until it can easily be picked from the bones. Then allow it to cool, separate it from bones and add the raw liver and the water-soaked bread from which the surplus water has been squeezed. The mass is then ground through the fine plate. Now add the ten pounds of soup in which the meat was cooked and the rest of the seasoning. If onion or garlic is used chop fine. The mass is then thoroughly mixed with a paddle or with the hands for about fifteen minutes and stuffed into beef casings which have been soaked in warm water. Borax added to the water at the rate of about two ounces per bucketful will keep the casings from getting mouldy. Liver sausage tied in strings of five or six sausages can be most easily handled. The sausage, when tied, is cooked in water, not quite boiling, until it floats, then plunged into cold water to cool. When the sausage is likely to spoil it may be put into a weak brine made by adding four pounds of salt to three gallons of water. It can also be kept fresh by putting into a barrel of clean water which has a large lump of ice in it. This sausage is best fried but may be cooked in other ways. It is often eaten with sauerkraut.

Blood Sausage—Blood sausage is made in the same way as liver sausage except that in place of the liver, blood, preferably from a hog, is added. It should be caught in a pail as it escapes and stirred continuously. A little salt added will aid in preserving the blood. Stir for five or ten minutes and strain through a milk strainer and use only the liquid portion. In mixing, back fat cut into cubes about the size of peas may be added.

Bologna—This is one of our most commonly used sausages. It is used in the harvest field more than any other sausage. It derives its name from the town of Bologna, in Italy, where it was first made and where the people use it extensively to this day. Now, no meat market is complete without Bologna sausage and no farmer's wife has completed her shopping unless she has purchased Bologna sausage to be used for lunch. The following recipe is a good one:

80 lbs. beef	10 oz. pepper
20 lbs. pork	15 lbs. water
2 lbs. salt	Garlic if desired

If both can be procured use about half fresh beef and half cured but always use fresh pork if possible. First grind the meat through the coarse plate, then add the seasoning, but if cured meat is used do not add any salt. Now grind through the fine plate at least once and preferably twice as it will then mix a great deal more easily. When the meat is ground and

in a tub, place the tub on a box or bench high enough so you can work your hands in the meat. Then add the water and mix for thirty or forty minutes or until the meat is sticky and not crumbly. Take a piece in the hand and squeeze it and you can tell immediately whether it is crumbly or sticky. The meat will appear dull in color if mixed thoroughly but if the water is not all absorbed the mixture will appear glossy or watery. It is now ready to be stuffed in soaked beef casings or rounds which can either be cleaned on the farm or purchased from the local butcher. Stuff tightly, tie, arrange on sticks so that no two sausages will touch, and hang up in the smokehouse. Smoke with hard wood, preferably hard maple or hickory. Clean corncobs may be used but never use soft wood. Smoke in a temperature of about 60° or 70° F.

Tomato Sausage—Tomato sausage is not often used because few people know what it is or how it is made. It should be made of pulp from fresh tomatoes. Of course, canned tomatoes can be used, but with only fair results. The following is a good recipe for tomato sausage:

1½ lbs. ripe tomato pulp	1 lb. crackers soaked in cold water
7 lbs. sausage pork	Salt and pepper to taste

First prepare the tomato pulp by taking out the juicy, seedy part and using only the pulp. Then while the meat is being ground through the fine plate the mass is seasoned with salt and pepper to suit the taste.

This sausage can be fried or baked in the form of a loaf, preferably the latter. If frying, turn over with a knife or a cake-turner so as not to puncture the outer crust and allow the meat juices to escape.

Summer Sausage or Cervelat—Summer sausage is made in the country during the winter and kept for use during the summer. As a lunch sausage it has become very popular because of its keeping qualities. It can be dried and cured so that it will keep for many months. It may be mixed in the following proportions:

25 lbs. cured beef	¼ to ½ oz. coriander
15 lbs. fresh pork fat	1 oz. whole mustard seed
7 oz. white pepper	

No salt is needed because the cured meat will supply enough salt for the mixture. The beef is ground through both the coarse and fine plates of the grinder but the pork is ground only through the coarse plate, preferably two or three times. The ground meat should be seasoned and the pork and beef mixed thoroughly for at least thirty minutes. It should then be spread out on a bench in a cold, dry place and allowed to dry and chill for from one to four days, depending upon the weather, and turned once or twice so that all the meat is thoroughly chilled. After it has been allowed to cool and dry for two or three days, it should be stuffed tightly in beef straights, or beef intestines, and then hung up to dry for about two days to give the seasoning a chance to act on the meat.

In smoking summer sausage, be very careful not to get the temperature above 70° F. In other words, the sausage should be smoked with cold smoke. If you have a low smokehouse it is better to make a smokehouse for cold smoke as shown in Fig. 10. The sausage should be smoked for from thirty-six to forty-eight hours, being very careful to have a continuous fire. A large piece of wood with a big knot in it will smoke all night.

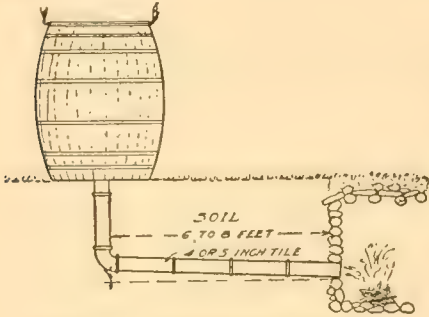

Fig. 10.—Cold Smoke Smokehouse.

The sausage should be kept in a cool, well-ventilated place. A little mould will improve the sausage, but if it spreads all over the skin it is harmful because it gives a mouldy flavor. If it begins to get too mouldy rub off the mould with a cloth dipped in a mixture of salt and lard.

This sausage is eaten cold. A good way to keep it is to pack it in oats, as they will absorb the moisture, but it ought to be well wrapped in cheesecloth if packed in oats.

If sausage gets a little slimy, put it back into the smoke-house and smoke it for five or six hours.

Head Cheese—Head cheese is usually made from pork but some beef or veal may be added in the following proportions:

20 lbs. pork	$\frac{1}{4}$ oz. allspice
5 lbs. beef	$\frac{1}{4}$ oz. cloves
$\frac{1}{4}$ lb. pepper	$\frac{1}{2}$ oz. caraway
$\frac{1}{2}$ lb. salt	4 lbs. soup

The pork is composed of heads, hearts, and tongues of hogs, and the veal or beef should be shank or neck. The meat is first boiled for about two or three hours, then separated from the bones. It is cut up by hand into half or quarter-inch cubes. Then the water in which the meat was cooked (soup) is added with the seasoning and the mass is thoroughly mixed by hand until the seasoning is properly worked through the meat. Onions may be added but they detract from the keeping quality of the mixture. This mixture is then put into hog paunches or beef straights and laid out to cool. They may be pressed by laying a weighted board over them. Serve either cold with vinegar or fried.

FRESH MEAT

Fresh meat is more palatable and desirable than salted or cured meat. On the farm, where there is no ice or cold storage of any kind, it is very difficult to keep meat fresh during the summer months, and only a small

amount can be handled at a time. It may, however, be kept for a few days, or even a week, in a cool cellar, where there is a free circulation of dry air, and flies and insects cannot get at the meat. A very convenient means of keeping a supply of fresh meat most of the time, is for two farmers to kill a calf or sheep every week or so, and divide the carcass. After the meat is cut into pieces of convenient size, it may be sprinkled with salt, which will greatly aid in keeping it.

During the winter months there is no difficulty in keeping fresh meat. It can be frozen or packed in snow, and kept in good shape. The most convenient way is to cut the carcass into desirable pieces for home use, and then put them out to freeze. Lay each piece out separately, so that it will freeze thoroughly. After this it may be packed in a box or barrel and kept frozen. To freeze a quarter of beef, and hang it in some place where it will remain frozen solid, is not so satisfactory as cutting it into small pieces, because it is more difficult to handle when a piece of meat is desired. Avoid alternate freezing and thawing, as that makes the meat flabby and also makes it lose its flavor.

Beef Clubs—Co-operative beef clubs are beginning to solve the problem of furnishing fresh meat for the farm home during the summer months, at a reasonable cost. Such a club is composed of twenty or more farmers, who organize and form a club to dispose of at least one beef each week. This is operated in connection with a creamery, or at some convenient place in the community. A beef is slaughtered once a week, usually on Friday evening, and put in a cellar to cool over night. The next morning the carcass is cut and divided into as many portions as there are members in the club. Each person gets a different portion of meat each week, until each has received a whole carcass. A price per pound for the different cuts is agreed upon, and cash paid for the meat. The proceeds are used for buying the animal and paying for the labor spent in dressing and cutting the carcass. These clubs have been successfully operated, and the farmers had fresh meat all season at a very small cost per pound during the summer.

Alphabetical and Analytical Index

	Page		Page
A-shaped hog house.....	554	Anthraxnose	
Abaca plant	910	—alfalfa	787
Acid and chemical treatment for		—bean	798
weeds	607, 620	—clover	787
Acid phosphate, cost.....	202	—raspberry	795
Acid phosphate in manure.....	204	Ants, to keep from cupboards.....	968
Acidity of soil		Anvil	891
—ammonia test for.....	169	Aphis	
—indicated by weeds.....	169	—apple	730-733
—lime test for.....	169	—corn-root	764
—litmus test for.....	166-169	—currant	713
—to correct for alfalfa.....	115	—English grain	673
—treatment for	172-179	—pea	691
Acidity of subsoil.....	401	—strawberry root	705
Alfalfa		—woolly apple.....	730
—as dry land crop.....	411, 432	Apple	
—as smother crop.....	623	—corers, parers	978
—benefit to alkali soil.....	171	—diseases of	789-793
—correcting soil for.....	115	—insect pests of.....	730-740
—cultivation	120	—sprays for	284
—diseases of	786	Architecture, farmhouse	471
—fallowing	120	Argentine Republic, rainfall.....	388
—field for	114	Army worms, 660; fall.....	662
—harvesting	120	Arsenate of lead.....	653, 656
—inoculation	116	Ash, for fence posts.....	938, 949, 950, 951
—inter-tilled	406	Ashes, wood, potassium.....	203
—nitrogen gatherer	194	Asparagus	224, 226
—seed selection	114	—beetle	704
—seed testing	28	Aspen, for fence posts.....	938
—sod, to plow	451	Aster	237
—sowing	120	Auction companies, product sold by	1062
—storage	121	Augers	886
—to clean	30	Australia, rainfall	388
—with timothy	142	Automobile, care of.....	877-879
Alkali soil, treatment.....	171-172	Awls	898
—spots in soil, cause.....	434	Ax	883
Alkalinity, soil, to test for.....	166-170	Babcock test, bottles, accuracy of	1135
Alsike clover, green manure.....	197	—calculating dividends by.....	1141
Alternate planting system.....	247	—composite samples	1137
Alyssum	238	—for cream	1133
Ammonia test for acidity.....	169	—for different cows.....	1127
Ammonium sulphate, cost.....	202	—for skim milk	1132
Analysis of soil, plant.....	163-164	—problems	1143
—value of chemical.....	163	—readings for	1123
Angoumois grain moth.....	45, 680	—steps in	1120
Animal to select for slaughter.....	1145	—taking samples for fat test.....	1130
Animals, weed seed distributed by..	640	—why used.....	1118
Annual, definition of.....	604	Baby buggies, uses for.....	983, 991
—sow thistle 619, colored plate of	610	Baby screen	984
Annual and biennial weeds, methods		Back firing	858
of eradication	606-611	Bacon	1166
Annuals (flowers).....	237		

- | | Page | | Page |
|-------------------------------------|-------------|----------------------------------|----------|
| Bacteria, cultures of..... | 117 | Beets | 222-226 |
| —soil, lime favorable to..... | 172 | —storage | 219 |
| —nitrogen fixing | 110, 136 | —to keep firm | 969 |
| Baking powder, home-made..... | 961 | —value of lime for..... | 176 |
| Balsam | 238 | Bench, a double purpose..... | 979 |
| —for fence posts | 949-951 | Birch, for fence posts..... | 938-951 |
| Bank check, use illustrated..... | 1005 | Birds, as insect destroyers..... | 748-761 |
| Bar | | —crops saved by..... | 750-756 |
| —claw | 887 | —enemies of..... | 756 |
| —iron | 904 | —food capacity of | 749-750 |
| —pinch | 896 | —nesting places (table)..... | 761 |
| Barberry, rust | 763 | —stomachs | 750-751 |
| Bare fallow, for weeds..... | 627 | —to attract | 757 |
| Barley | | —to protect vegetation (table).. | 761 |
| —amount of water needed for... 392 | | Biennial, definition of..... | 604 |
| —as dry land crop..... | 409, 422 | Bill-bugs | 676 |
| —cultivation | 89 | Bills payable, defined..... | 1002 |
| —culture | 88-90 | —receivable, defined | 1001 |
| —diseases of | 771-773 | Bins (grain) | |
| —harvesting | 89 | —care of | 46 |
| —plant food removed by..... | 191 | —construction | 50, 51 |
| —rotation | 88 | —to find cubic contents of..... | 47 |
| —seed | 33 | —to fumigate | 47-49 |
| —seed-bed | 88 | Bits, gimlet, screw driver..... | 886 |
| —seeding | 88 | Bitter rot, apple | 790 |
| —smut | 40 | Blackberries | 299 |
| —soil for | 88 | —diseases of, see Raspberry | |
| —sweating | 89 | Black mould, clover..... | 787 |
| —to clean | 30 | Black rot, tomato | 799 |
| —with alfalfa..... | 120 | Black rust | 763 |
| Barn | | Blackheads, wheat | 765 |
| —beef cattle | 536-539 | Blackleg, potato | 784 |
| —combination | 543-546 | Blacksmithing, tools for..... | 902 |
| —dairy | 481-507 | Blade blight, oats..... | 771 |
| —horse | 540-542 | Blankets, to wash | 992 |
| —location of | 469 | Blast, oats | 771 |
| —sheep | 575-577 | Bleaching | 989 |
| Barrett's Grade-One-Creosote | 943 | Blight | |
| Bars, iron | 904 | —apple | 792 |
| Basements, concrete | 339 | —bean | 798 |
| Basic slag, cost of..... | 202 | —control, by rotation | 41 |
| Basswood, for fence posts..... | 938-949-951 | —oats | 771 |
| Batteries | 855 | —pea | 800 |
| —exhausted | 852 | —potato | 777 |
| Baume scale of gravity..... | 830, 831 | —raspberry | 795 |
| Beans | 224-226 | Blinding | 377 |
| —diseases of | 798 | Blister beetles | 666, 688 |
| —soy (see soy beans) | | Blotting paper tests | 54 |
| —weevil | 691 | Blowing, soil | 207 |
| "Bear," explained as trading term.. | 1078 | Bluegrass | |
| Bedding, to conserve manure..... | 183 | —comparison with brome and | |
| Beef clubs..... | 1173 | quack grass | 626 |
| Beef, corned | 1165 | —to fight weeds..... | 611 |
| —cuts of | 1157 | Bluestone | 788 |
| —dried | 1166 | Boiler, for the laundry..... | 985 |
| —killing and dressing..... | 1153 | —use in canning..... | 965 |
| Beetle | | Boll weevil | 651, 741 |
| —asparagus | 704 | Bolley, H. L. quoted..... | 414 |
| —blister | 688 | Bolts, iron | 905 |
| —cucumber | 697 | Bone meal, cost of..... | 202 |
| —grain | 679 | Book-keeping | |
| —(maul) | 896 | —essentials | 998 |
| —potato | 657 | —value of | 1025 |
| | | Boots and gloves, to soften..... | 969 |

	Page		Page
Borax, use in starch.....	991	Butter	1139
Bordeaux mixture	655	—hard, to spread.....	966
—preparation of	788	—marketing	1061, 1062, 1065
Borders, flower	230	—milk	1140
Borer		—rancid, to sweeten.....	966
—currant	712	Butterfat	
—flat headed apple.....	731	—in grades milk.....	1138
—grape cane	715	—overrun in	1137
—raspberry cane	710	Bush fruits	
—raspberry root.....	710	—blackberries	299
—round headed apple.....	731	—currants	300
—strawberry crown	706	—culture of	291-302
Boss, Andrew, quoted	633	—dewberries	299
Bottles, to clean.....	969	—diseases of	795
Bound boxes	862	—gooseberries	302
Brace and bits.....	885	—raspberries	291-299
Brake test	834	By-Laws, for co-operative associa-	
—how conducted.....	835	—tions	1104
—power, how to figure.....	836	Byturus, raspberry	712
—when to use	837	Cabbage (culture)	222, 226
Bran mash, poisoned.....	604	—diseases of	800
—sweetened	666	—maggot	693
Bran wheat, value as soil builder... 191		—storage of	219
Brass, to clean.....	968	—worm, imported	694
Bread		Cake	
—board, to make.....	982	—board, to make.....	982
—crumbs to keep.....	958	—mixers	975
—mixers	975	—pans	954, 982
—pans	982	—pointers in making.....	960-962, 966
—uses for dried.....	958	Calcium cyanamide, cost of.....	202
Bread-making pointers	958, 966	Calf pen	500
Breeding records	1008	California circular, referred to.... 1084	
Brine, for meat	1165	Calibrator, Trowbridge	1135
Brokers, duties of.....	1062	Calliopius	238
Brome grass, culture.....	412	Canada field pea (see field peas)	
—seeding	422	Canada thistle	628
—to compare with quack grass... 625		Candy-making hints.....	960, 966
Brooder house, chicken.....	573	Cane blight, raspberry.....	795
Brooms, use and care.....	968	Cane-borers	
Brown rot, cherry, plum.....	793	—raspberry	710
Brown-tail moth	724	—grape vine.....	715
Brushes, household uses for.....	982	Canker	41
Brussels sprouts	222	—apple	793
—storage	219	—worms	726
Buckhorn seed, to remove.....	30	Canning fruits	962-965
Bud moth	737	Canning vegetables	220, 965
Buffalo tree hopper.....	721	Canvas dams	458, 462
Buffet, a home-made	981	Capillary water, in soil.....	390
Bulbs	238	Carbon bisulphide	48, 655
“Bull” explained as trading term... 1078		Carbon, deposits to remove.....	871
Bull pen.....	499	Carburetion in gas engine.....	822
Bunt, wheat	765, 766	—how to get proper mixture.....	824
Butchering		—lean and rich mixture.....	824
—cattle	1153	—process of	823
—hogs	1147	—requirements of	823
—poultry	1163	Carburetors vs. mixing values.....	825
—sheep	1160	Carey act	427
—to select animals for.....	1145	Carrots	222, 226
—tools	1147	—storage of	219
—veal	1159	Carpet sweeper, to clean.....	969
		Carpets, to clean.....	968, 993
		Carrots, to keep firm.....	969

	Page		Page
Cash accounts, method of keep- ing	1002-1005	Cippoletti weir	441
Cash book, special column.....	1004	Cisterns, concrete	349
Case-bearer, pistol and cigar.....	737	Clamp, harness	898
Casserole, its use.....	976	Clan bar	887
Catalog houses, buying from.....	1063	Clay soil	
Catalpa, for fence posts.....	938	—composition of.....	165
Caterpillar, hawk moth.....	716	—drainage of	370, 373, 374
Cattle		—effect of lime on.....	172
—barn	536-539	—movement of water in.....	390
—killing and dressing	1153	—need of phosphorous.....	165
—cutting up	1157	—plowing	398
—peas to fatten	149	—potassium in.....	165
Cauliflower	222, 226	—water hold capacity of.....	206
Cedar, white, red, for fence posts	938, 939, 950, 951	Clean culture-clover-crop system..	269
Ceiling, to paint.....	969	Cleaning seed	29-31
Celery	222, 226	—adherence method	30
—caterpillar	703	—fanning mill	29
—leaf tyer.....	702	—gravity	30
—storage of	219	—screening	31
—unblanched	219	Clematis	241
Cellar ways, concrete	353	Clonal test plat.....	144
Cement		Clover (culture)	109-113
—block silo.....	525	—amount of water needed for... 392	
—blocks, to make.....	525	—as cover crop.....	272
—Portland	300	—burr	111
—wash for silo.....	525	—crimson, as cover crop.....	272
Centrifuge	1124	—cutting of	111
Cereal, drop diseases.....	762-776	—diseases of.....	787
—prevention of	802	—green manure crop	196-197
Cereals		—harvesting of	112
—effect of manure on.....	187	—inoculation of	109
—hints in cooking.....	959	—insects injurious to.....	682-684
Chafer, rose	716	—nitrogen gatherer.....	195
Chaff, removal of.....	29	—plant food removed by... 165, 191	
Chain stores, development of.....	1063	—rotation	113
Chairs, convenient	979, 980	—seed	113
Chalcid, clover-seed	684	—seed-bed	109
Chalk line	887	—seed farming	1033
Chamois, to clean.....	993	—soils for	110
Charlock	616	—sowing	110
Charring, to preserve timber.....	993	—storing	112
Cheat	618	—sweet	197, 412, 422
Check board.....	454	—testing seed	28, 111
Check book, use of.....	1005	—to clean seed.....	30
Checking	76	—to control weeds.....	609
Cheese	1140	Clothes	
—head	1172	—drying hints	990, 991
—factories, co-operative .. 1094-1106		—horse	979
Chemicals, to kill weeds.....	607-620	—pins	990, 991
—use of on weeds.....	620	—sprinkler	990
Cherry, diseases of (see Plum)		—stick	985
Cherry stoner	979	—washing hints	991-993
Chess	618	Club, beet	1173
Chicago Butter and Egg Board, the	1068, 1069	Club root cabbage.....	800
Chicken, to clean.....	966	Clubs, farmers'	1107
—uses for fat.....	961	—advantages of	1107
Chickens, dressing of.....	1163	—to organize.....	1110-1113
Chinch bug	662	—work of	1113
Chisels, cold	886, 890	—results	1116
Cicada, periodical	722	Coal tar, to preserve timber.....	942
Cigar, case-bearer	737	Cocoa, in cake.....	960, 961
		Codling moth	738
		Coffee percolator.....	978
		—to clear.....	982

	Page		Page
Coil, adjustment of vibrator in..	855, 871	Concrete Construction	305-360
Coir fiber	911	—tables for basements	339
Cold-frame	213	—colors	321
Colorado potato beetle.....	687	—fence posts.....	357
Coloring, for concrete.....	321	—one hundred square feet	332
Colors, to set in washing.....	992	—two-bag batch.....	313
Combination barn.....	543-546	Conservation of moisture.....	205-206
Combustion, gas engine.....	825	—cultivation, effect on.....	206
—fuels	825	—experiment	206
—principles of	812	—fall plowing, effect on.....	206
Comforters, to wash.....	992	Contract grade in wheat.....	1078
Commission merchants	1064, 1065	Contract sales	1066
Commercial fertilizers	201-205	Contour lines	457
—cost of.....	202-203	Cookies, baking hints for.....	960, 981
—experiments with	203-204	Co-operative creameries and cheese factories	1094-1106
Composting manure	182-183	—advantages of	1101
Composting to kill weeds.....	640	—articles of incorporation.....	1102
Concrete		—building for	1099
—cisterns	349	—butter- or cheese-maker for....	1100
—coloring	321	—by-laws	1104
—composition	306	—to organize	1049-1099
—contraction of	329	Co-operative organization	1082-1093
—ditch lining	436	—conditions for successful..	1084-1087
—division boxes	452	—fundamental principles of....	1082
—fence posts.....	356, 357	—in Minnesota	1087-1093
—floor for dairy barn.....	483, 504	—limitation of shares in	1083
—floors	328, 333	—management and accounting of	1085-1086
—forms	324	—need of business for.....	1086, 1087
—foundation for silo.....	510	—need of capital for.....	1087
—foundations	337	—need of loyalty for.....	1087
—manure pit	346	—one man one vote in.....	1082
—materials for 100 square feet of	332, 345	—patronage dividend in....	1083, 1084
—measuring box	303	—specific object required in....	1085
—milk vat	345	Co-operative stores in Minnesota..	1090, 1091
—mixture	312	Copper, to clean.....	967
—one-course work	329	Copper sulphate	788
—piers	338	Corers, apple and pineapple.....	976
—placing	321	Corn (culture)	60-77
—proportions in mixing.....	311	—amount of water needed for....	392
—protection	322	—as dry land crop.....	409, 422
—reinforcing	323	—checking	76
—roof for silo	523	—cultivating	75
—root cellar	589	—curing and storage.....	64
—septic tank	350	—effect of manure on.....	187
—sidewalks	329	—harvesting	77
—silo	527, 535	—horse	77
—slipperiness	335	—insects injurious to.....	674-678
—step and cellarways.....	353	—kafir	407, 410
—stucco	359	—listing	423
—sub-foundations for	329	—marks of poor seed.....	162
—to mix.....	317	—plant food removed by.....	165, 191
—to prevent sticking.....	326	—planting	75
—tools	326	—plowing	74
—two-bag batch	313	—seed selection	77
—two-course work	313	—seed testing	66
—upheaval and scaling.....	329	—shelling and grading	72
—walls	340	—smut	40, 776
—weir boxes.....	442	—storage	46-64
		—testing	66
		—to measure in the crib.....	1001

- | | Page | | Page |
|--|------------|-------------------------------------|-----------------|
| Corn, tree | 65 | Cucumber | 224-226 |
| —rotation for | 1035 | —beetle, striped | 697 |
| —with speltz | 408 | —diseases | 799 |
| Corn spurry, as indication of acidity | 168 | —wild | 241 |
| Corn starch for thickening | 966 | Cultivation | |
| Corrosive sublimate | | —to kill weeds | 608 |
| —for preserving milk samples | 1121 | —to hold soil moisture | 206 |
| —to disinfect potatoes | 786 | —surface | 404 |
| Corrugators | 460 | Cultivators, for dry farming | 419 |
| Cosmos | 238 | Cupboards, handy | 953 |
| Cotton (culture of) | 100-108 | —in bottom step | 984 |
| —boll weevil | 104, 741 | Curing meat | 1164 |
| —cross fertilizing | 107 | Curculio, grape | 717 |
| —cultivation | 102 | —plum | 727 |
| —early maturing | 104, 106 | Currant, insects injurious to | 712-714 |
| —fertilizers | 101 | —leaf spot | 797 |
| —for rope | 910 | Currants, culture of | 300 |
| —grading and marketing | 103 | Curtains, to stretch | 993 |
| —improvement of | 107 | Custard, curdled | 966 |
| —picking | 103 | Cutworms | 658 |
| —planting | 102 | Cylinder | 813 |
| —seed-bed | 100 | —overhauling | 870 |
| —seed-oil, as shortening | 107 | —thumping in | 850 |
| —seed selection | 104 | —troubles | 858 |
| —soils for | 100 | —water in | 849 |
| —structure of flower | 107 | Dahlia | 239 |
| Cotton flannel test | 56 | Dairy barn | 481-507 |
| Cotton wood, for fence posts | | —bull pen | 499 |
| 938, 939, 950, 951 | | —ceiling | 485 |
| Cover crops | 270 | —floors | 483 |
| Covered smut, barley | 773 | —lighting | 494 |
| Cow | | —manure pit | 501 |
| —cost of raising and keeping | 1025 | —plans | 481-484, 502 |
| —testing | 1127 | —round | 502-507 |
| Cows | | —stalls | 495 |
| —acreage required for | 1048 | —ventilation | 485-494 |
| —feeding | 1046 | —water supply | 500 |
| —“robber” | 1119 | Dairy farm | 1045 |
| —rule for feeding | 1128 | Dairy thermometer | 982 |
| Creaking doors and windows, to prevent | 969 | Dairying, science of | 1118-1144 |
| Cream, composite samples of | 1137 | (See Babcock test, index) | |
| —overrun | 1139 | Daisy, ox-eye | 634, plate, 620 |
| —scales | 1133 | Dandelion | 222 |
| —testing of | 1133 | Dassel Farmers' club | 1116 |
| —to whip | 965 | Dead engine, causes of | 856 |
| Creamery, co-operative | 1094-1106 | Deposits, gas engine | 863 |
| Creosote | | Derrick | 519 |
| —cost of | 951 | Dewberries | 299 |
| —to preserve timber | 943 | Dianthus | 238 |
| Cress | 222 | Dikes, irrigation | 475 |
| Cricket, tree | 711 | Diseases, plant | 762-802 |
| Crisco, as shortening | 961 | —alfalfa and clover | 786 |
| Crop cost, tables and illustrations | 1020, 1021 | —cereals | 762-776 |
| —yield, to record | 1008 | —economics, importance | 762 |
| Cropping, orchard | 275 | —garden and truck crops | 798-802 |
| Crops saved by birds | 750-753 | —nature of | 762 |
| Cross-fertilizing cotton | 107 | —orchard | 788-795 |
| Crown gall, raspberry | 795 | —potato | 777-786 |
| Crown, spliced | 913 | —small fruits | 795-798 |
| Crowbar | 896 | —summary of control methods | 802 |
| Cubic feet per second | 439 | Dishwashing | 968, 976 |
| | | —machine for | 975 |
| | | Disk plowing | 399 |

	Page		Page
Dirt mulch, theory of.....	394	Dry Farming, size of farm.....	424
Ditch (drainage)		—soil for	424
(See surface ditch)		—soil moisture	389-393
Ditches (irrigation)		—summer fallow	415
—borrow	453	—ten commandments of.....	425
—construction of	451	—tillage operations	394-406
—head	436, 454, 458	—trees and shrubs.....	416
—linings of	434	Dry land farmer, rules for.....	393
—waste	454	Ducks, dressing	1163
Ditching machines	451	Dumb waiter	953
Dividend, patronage.....	1083, 1084	Duluth, wheat prices.....	1076
Dividers	896	Durum wheat	407
Division boxes	454	—seeding	422
Dorothy Perkins' rose.....	241	Dust, dangers of.....	981
Double boiler	957, 978	Duster, dustless	980
Double cookers	978	Dustpan, long handled.....	984
Doughnuts, frying	962	Duty of water	428, 429, 437
Downy mildew, grape.....	797	Dykes, with surface drain.....	387
Drain boards, in kitchen.....	953	Ear-worm, corn	677
Drainage, land	363-387	Early blight, potato.....	777
—amount needed	373	Egg plant	223-226
—benefits of	171, 364	Egg records	1007
—cost of	379	Egg whites	965
—effect on weeds.....	637	Eggs	965
—engineer	387	Eggs—marketing	1061-1062
—laying out system of.....	365	Electrodes	852
—legislation on	363	Elements	
—methods of	370	—deficient	164
—of close soil.....	370, 373, 374	—effect of crop upon.....	164
—of lake bed	380	—for plant growth.....	162
—of meadow	381	—removed by crops.....	165
—of open soil.....	370, 373, 374	—to determine required.....	163
—of peat land	382	Elevator companies	1073-1075
—of pot holes	371	—methods of business.....	1079-1080
—outlets	372	Elevator (granary)	578
—profit of	383	Elgin Butter Board	1068-1069
—projects	380	Elliott, C. G. (quoted).....	363-373-383
—random field	371	Elm, red, white, for fence posts... 938	
—subsurface	370	Emmer culture	409
—surface	370, 384	—seeding	422
—surveying for	366	Endive	222-226
—tile	373, 375, 379	English sparrow.....	749-753-757
—tools	375	Entomologist (state)	
—trench	374, 377, 379	—for Hessian fly.....	80
Drains, land,		Equipment, farm repair of.....	880-908
—capacity of	373	Ergot, rye	775
—distance apart	371	Erosion, control of.....	208
—intercepting	371	Evaporation	391
—location of	370	Experiment station, seed test.....	28
Drawbar, horsepower	833	Fallow, summer	415
Dried blood (fertilizer), cost.....	202	Fanning mill	78
Drills	892	Farm	
Drinking cup, birds.....	757	—as factory	467
Drinking cup, cattle.....	494	—arrangement of buildings.....	468
Drippings, savory	958	Farm buildings	467-600
Dropping boards	564	—beef cattle barn.....	536-539
Dry farming	388-426	—combination barn	543-546
—crops	407-416	—dairy barn	481-507
—definition of	389	—farmhouse	470-480
—live stock	414	—farmstead	467-469
—machinery	417-423	—granary	578-580
—rainfall, necessary for.....	424	—hog house	547-559
—rules for	393	—horse barn	540-542
—seeding	422	—machine shed	592-594

- | | Page | | Page |
|-------------------------------------|------------|---|-----------|
| Farm buildings, paints and painting | 598-600 | Farming | |
| —potato warehouse | 581-587 | —clover seed | 1033 |
| —poultry house | 560-574 | —dairy | 1045 |
| —root cellar | 589-591 | —live-stock | 1036 |
| —sheep barn | 575-577 | —profit from different type | 1052 |
| —silos | 508-539 | Farmstead | 467 |
| Farm equipment, repair of | 880-908 | Farrel (quoted) | 397 |
| —combination outfits | 900 | Fat | |
| —harness repair | 898 | —for soap making | 987 |
| —harness supplies | 907 | —in cooking | 957-958 |
| —iron working tools | 888 | Feathers, to clean | 993 |
| —materials for | 904 | Feed requirements of stock | 1031-1037 |
| —metal materials for | 904 | Feeding rack, outdoor | 539 |
| —miscellaneous tools | 896 | Feeding records | 1011 |
| —paints, etc. | 907 | Felt hats, to clean | 994 |
| —shop | 902 | Fence posts, concrete | 357 |
| —wood materials for | 904 | Fence posts, preservation and treatment | 937-951 |
| —wood working tools | 883 | —costs of | 938 |
| Farm management, office of | 1028 | —decay of | 939 |
| Farm manure | 179-192 | —durability of | 939 |
| Farm map | 1009 | —oil treatment | 944 |
| Farm products, marketing of | 1057-1072 | —substitutes | 938 |
| Farm property, value | 1000 | —to prevent rotting | 940 |
| Farm records and accounts | 997-1026 | —untreated posts | 937 |
| —breeding | 1008 | Fencing | 1055 |
| —cash account | 1002 | Fender, for pig pen | 547 |
| —cost investigations | 1023 | Fertility | |
| —essentials in | 998 | —elements of | 162 |
| —feeding | 1011 | —relation of farming to | 191-192 |
| —household | 1015 | Fertilizers | |
| —inventory | 998 | —commercial | 201-205 |
| —labor | 1010 | —for cotton | 101 |
| —map | 1009 | —for garden crops | 212 |
| —milk production records | 1005 | —for orchard | 276 |
| —profit | 1017 | —for potatoes | 123 |
| —seeding records | 1016 | —for sorghum | 94 |
| —summarizing | 1017 | —for sugar cane | 96 |
| —value of | 1025 | —for timothy | 143 |
| Farm replanned | | —for wheat | 82 |
| —dairy | 1045 | —plats for | 123 |
| —grain and clover | 1034 | —soil testing by | 166 |
| —grain and clover seed | 1032 | —to reinforce manure | 204 |
| —grain and hay | 1030 | Field | |
| —hog | 1042 | —management | 1052 |
| —summary of returns | 1051 | —observation | 163-164 |
| Farm supplies, value | 1001 | Field peas | |
| Farm vegetable garden | 211-227 | —amount of water needed for | 392 |
| Farmer, as drainage engineer | 387 | —as cover crop | 272 |
| Farmers' clubs | 1107-1117 | —as green manure | 146, 197 |
| —advantages | 1108 | —culture | 146-149 |
| —organization of | 1110-1113 | —diseases and pests | 149-800 |
| —results of | 1116 | —feeding value | 149 |
| —work to do | 1113 | —fertilization and rotation | 146 |
| Farmers' elevators | 1074, 1075 | —harvesting | 147-148 |
| —in Minnesota | 1089 | —hay crop | 148 |
| Farmhouse | 470-480 | —preparing soil | 146 |
| —L-type | 468 | —seed crop | 147 |
| —location | 469, 471 | —soil and climate | 146 |
| —plans | 473-480 | —sowing | 147 |
| Farming, business side of | 997-1173 | —storing | 147 |
| | | —threshing | 148 |
| | | —uses of | 149 |
| | | —varieties of | 148 |

	Page		Page
Files	891	Forge	890
Fillers, orchard	248	Fork, pastry	979
Fire blight, apple	792	Formaldehyde treatment	
Fireless cookers	971-973	—flax	152
Flannels, to wash	992	—smut	36, 766
Flat irons	958, 986	Forms, for concrete	324
Flax (culture)	150-156	—cellar wall	338
—as dry land crop	410, 422	—fence posts	356
—climate	151	—foundations	336
—danger in wetting	154-155	—hog trough	345
—diseases	141, 775	—hollow wall	340
—effect of manure on	187	—manure pit	348
—effect upon soil	151	—stair	353, 354
—feeding value	156	—tanks	343
—for rope	911	Foundations, concrete	337
—harvesting	154	Four-cycle engine	815
—irrigation	154	Frederick, Mrs. (quoted)	953
—on new land	156	Frederick the Great, destruction of	
—rotation	152	sparrows	752
—seed-bed	153	French chalk	987
—seed treatment	152	French weed	613
—seeding	153	Frosting, cake	960
—storage	155	Fruit	
—threshing	155	—cake, baking hints	961
—uses	156	—growers' associations	298
Flea beetle	651	—small, see Bush Fruits.	
—grape vine	715	—to protect from birds	757
—pale striped	701	Fruit trees	
Flock management	1038	—care before selling out	257
Flooding, irrigation	456	—ordering from nursery	255
Floors		—planting	259-263
—concrete	328, 333	—pruning	277-284
—to oil	968	—selection	251
Flour sifters, use for old	983	—spraying	284
Flow of water, to compute	446	—top pruning	263
Flower garden	228-242	—wounds	282
—borders	230	Fruits	
—location	232	—canning	962-965
—planting	234	—to keep	970
—planting scheme	231	Frying	
—planting table	242	—basket	982
—soil	233	—pan	983
—treatment of lawn	230	Fuels	
Flowers		—gas engine	828-832
—annuals	237	—composition of	825
—borders	230	—mixture	824
—bulbs	238	—supply	861
—care of	233-236	Fuller's earth, to remove stains	987
—on lawn	230	Fumigants	635
—perennials	236	Fumigation, grain	47
—planting table	240	Fungi, in soil	768
—shrubs	241	Fungous diseases, to control	220
—to send by mail	969	Furniture, to clean	969
—vines	240	Furrow dust, to kill	
Flues, ventilating	489-494	—insects	664
Flumes	454	Furrow, irrigation	458
Fly, as disease carrier	744	Fusarium wilt, potato	781
Fly specks, to remove	968	Future trading, grain	1077-1085
Food ball for birds	758	Gang mould	525
Food chopper, uses for	976	Garbage, care of	744
Foot warmer	983	Garden and orchard	211-302
Forbush, Dr. (quoted)	752	Garden and truck crops, diseases of	
Forest Service U. S.	950	798-802
Forestry, college of, Minn.	951		

- | | Page | | Page |
|---------------------------------------|---------------|--|---------------|
| Gas engine | 805-879 | Gravity scales | 831 |
| —care of | 865, 868, 872 | Gravy, hints on making | 966 |
| —cheap | 875 | Greeks, method of preserving tim-
ber | 941 |
| —combustion | 825 | Green manure | 193-200 |
| —fuels | 828-832 | —crops | 196-199 |
| —horse power | 833-838 | —effects of | 194, 196, 200 |
| —operation | 815-821 | —use of | 199, 200 |
| —parts | 813 | —value of | 193, 194 |
| —selection | 873 | Grindstone | 897 |
| —starting | 866 | Groceries, tins for | 968 |
| —stopping | 866 | Ground limestone | 174 |
| —testing | 834 | Grubs | |
| —troubles | 847-865 | —eaten by hogs | 75 |
| —uses | 806-811 | —white | 657 |
| Gaskets, leaky | 863 | Guide for circular brick laying | 518 |
| Gasoline | | Gurler silo | 510 |
| —commercial | 830 | Gypsum | 162 |
| —engine household use for | 975, 985 | —indirect fertilizer | 163 |
| —power of, compared to kerosene | 832 | —to preserve manure | 204 |
| —stove | 976 | Gypsy moth | 725 |
| Geese, dressing | 1163 | Hairbrushes, to clean | 968 |
| Germination tests | 53-57 | Hairy vetch, green manure | 198 |
| —blotting paper | 54 | Halters | |
| —box tester | 57 | —adjustable | 924 |
| —corn testing | 66 | —non-adjustable | 919 |
| —cotton flannel | 56 | Hamburg steak | 1169 |
| —experiment station | 28 | Hammers | |
| —seed list for | 54 | —blacksmith | 891 |
| —time table for | 56 | —claw | 887 |
| Gladiolus | 239 | —riveting | 889 |
| Glassware, to toughen | 967 | Hams, sugar cured | 1166 |
| Gloves, to wash | 993 | Hand lotion, to make | 969 |
| Glue, to remove | 968 | Hand saws | 884 |
| Gooseberries | 302 | Hangers, power house | 844 |
| —diseases of | 797 | Hardwood floors, to oil | 968 |
| Gospel of dry farming | 393 | Harness | |
| Gouger, plum | 728 | —repair | 898 |
| Grade line | 368-374 | —supplies | 907 |
| —to determine | 365 | Harrows, for dry farming | 417 |
| Grader, for irrigation purposes | 450 | Hatchet | 884 |
| Gradient slope | 374 | Hats, to clean | 994 |
| Grain (see Seed) | | Hawk-moth caterpillar | 716 |
| —bins | 46, 50, 51 | Head ditches, irrigation | 436, 454, 458 |
| —crops, diseases of | 762, 776 | Head gates | 452 |
| —infested | 45 | Hedging, trade | 1078-1080 |
| —louse, English | 673 | “Heeling-in” | 257 |
| —storage of | 46, 50 | Hellebore | 653 |
| —the marketing of | 1073-1081 | Hemp, for rope | 910 |
| —to kill insects in | 45-49 | Henshaw, Dr. (quoted) | 757 |
| Grains, insects injurious to | 657-673 | Hessian fly | 80, 651, 669 |
| Granary | 578-580 | Hexagonal planting system | 247, 249, 250 |
| Grape | | Hinges, strap | 906 |
| —berry moth | 717 | Hitches | 915 |
| —cane borer | 715 | Hitchings mulch | 268 |
| —curculio | 717 | Hog farm | 1042 |
| —diseases of | 797 | Hog house | 547-559 |
| —flea beetle | 715 | —location | 469 |
| Grape fruit seed, uses for | 970 | —movable | 553-559 |
| Grass, brome | 412-422 | —permanent | 547-553 |
| —crops, insects injurious to | 657-673 | —plans | 547, 550, 553 |
| —effect of manure on | 187 | —sanitation | 559 |
| —Sudan | 413-422 | —troughs | 344, 559 |
| Grasshoppers | 664 | —yard | 553 |
| Gravel, for concrete | 309 | | |

	Page		Page
Lard, leaf	1151	Lime, kind to use.....	176
—rendering	1168	—prepared	175
Late blight	777	—rapidity of action.....	176
Laterals, distance between.....	374	—test for acidity.....	169
—joining of	375	Limestone, cost	174-175
—size of	373	Lime sulphur	654
Laterals, irrigation, damming.....	456	—preparation of	789
—losses of water in.....	436	Line shaft, using a.....	808
Laundry saving devices and helps	985-994	Linen, to whiten	989
Laundry bag	990	Linseed oil	156
Lawn, flowers on.....	230	Listing (corn)	433
—treatment of	230	Litmus paper	115
Leaf-bug, four-lined	713	—test	166-169
Leaf-miner, apple	736	Live stock	
Leaf-roller, strawberry	707	—costs and receipts.....	1022-1023
Leaf-spot, alfalfa	786	—farming, problem of.....	1036
—clover	787	—inventory values	1001
—currant	797	—plant food removed by.....	191
—gooseberry	797	—shipping association	1091-1092
—pea	800	—with dry farming.....	414
—raspberry	796	Liverpool, as a wheat market.....	1076
—strawberry	797	Loam soil, power to hold moisture. .	206
—tomato	799	Locust, for fence posts.....	938-949
Leaf-tyer, celery or greenhouse... .	702	Locust, Rocky Mountain.....	665
Leaf-weevil, clover	682	—seventeen-year	722
Leather, for repairs.....	907	Log ditcher	451
—to soften	969	London bridge, piling of.....	941
Leek, seeding	227	Loose smut	
—storage	219	—barley	771
Legumes, as cover crops.....	272	—wheat	765
—for dry land.....	414	Louse	
—nitrogen gathering	196	—apple	730, 733
Lettuce	222-226	—corn root	674
Level, spirit	888	—currant	713
Leveling instrument, cost of.....	366	—English grain	673
—description	368	—pea	691
—necessity of	365	—strawberry	705
—operation of	366	—woolly apple	730
Lifter, for hot pans.....	978	Macaroni wheat	407
Lightning, protection from.....	595-597	Machine shed	592-594
Light-weight seed.....	28-33	—location of	469
Lime, amount to apply.....	175	Machines, run by gas engine.....	810
—agricultural	175	Machinery and tools, to inventory..	1001
—application of	173-174	Maggot	
—application on peat soil.....	166	—apple	739
—application on sandy soil.....	165	—cabbage	693
—compounds	174	—onion	703
—corrects acidity	172	—seed corn	675
—cost of	174	Magneto troubles	866
—crops benefited	178	Main drain	
—crops not benefited.....	173, 178	—capacity of	373
—definition of	162	—location of	370
—effect on phosphorus and potas- sium in soil.....	172	—slope of	373-374
—effect on physical conditions of soil	172	Mammoth red clover, green manure crop	197
—effect on bacteria	172-173	Management of a bearing orchard ..	266-285
—experiments with	169-170	Manger, individual	498
—fineness of division.....	176	—watering from	501
—form to use.....	174	Mangles, kinds and uses.....	986
—handling	177	Manila, fibre for rope.....	910
—harmful effects of.....	173		
—hydrated	175		

	Page		Page
Manure		Meat, cuts of pork	1132
—amount to apply	189-191	—fresh	1172
—application of	179-193	—hints on using	957, 958
—care of	181-189	—mutton	1160
—composition	179-180	—poultry	1163
—conserving plant food in	183-184	—recipes for	1165
—disease spores in	641	—sausage	1168
—disposal of	744	—selection of animal	1145
—effect on crops	188-189	—smoking	1167
—effect on soils	187-188	—veal	1159
—for garden crops	212	Mice and rats, to do away with	968
—frequency of application	189-190	Michigan, swamp land	363
—lasting effect of	186	Middlemen	1061
—liquid	180	Midge, clover-seed	683
—losses from leaching	181-183	Mignonette	238
—per cent of nitrogen phosphorus, potassium	180	Mildew	
—per cent of water	180	—downy	797
—re-inforcing	204	—powdery	797-799
—solid	180	Milk	
—straw, precaution in using	44	—condensed	1141
—time of application	189-190	—grades of	1138
—value of	181, 184, 185	—plant food removed by	191
—weed seed in	640	—record	1129
Manure pit	501	—scale	1128
Manure pits, concrete	346	—sheet	1142
Map, of farm	1009	—skim, to test	1132
Maple, for fence posts	939, 949, 950, 951	—to calculate weight of fat	1127
Marigold	238	—weighing of	1128
Marker, for round concrete floors	504	Milk-testing	1120
Market, public	1071	Milk-testing	
Marketing of farm products	1057-1072	—calculating dividends by	1141
Marketing of grains	1073-1081	—for cream	1135
Marketing		—for different cows	1127
—at country points	1061, 1073	—for skim milk	1132
—by parcel post	1071	—mixing samples for	1120
—cost of	1058	—problems	1143
—defects in system of	1069	—readings for	1123
—education in	1071	—to preserve samples	1121
—government regulations in	1071	Millet	
—grain in Minneapolis	1076	—as cover crop	273
—specialization in	1060	—for dry farming	406, 411, 422
—through auction companies	1062	Milo maize	410
—through brokers	1062	Mineral salts, to preserve timber	942
—through retail stores	1063	Miner's inch	439
Marlatt, C. L. (quoted)	651	Minneapolis	
Marsh, drainage of	370, 371	—prices of market products	1059
Martin houses	759	—wheat market	1076-1080
Massachusetts		Minnesota	
—control of gypsy moth in	725	—College of Forestry	951
—experiment station, orchard experiment	276	—co-operative organizations in	1087-1093
—insects consumed by birds in	748	—State Art Society	473, 474
—state board of agriculture in	752	—swamp land	363
Maul	896	—University farm	950
Meadow, drainage of	381	Misfiring	858
Meals, labor-saving plan of preparing	954	Miterbox	900
Measuring box	312	Mixture (see Fuel Mixture)	
Measuring cup	982	Mixtures	
Meat		—concrete	312
—curing	1164	—consistency of	320
—cuts of beef	1157	—timothy	142
—cuts of mutton	1162	Moisture, soil	
		—conserving	205, 389, 393
		—cultivation for	206

- | | Page | | Page |
|--|---------------|--|--------------------|
| Moisture, soil, experiments in..... | 205 | Nitrogen in soil, experiments... | 194-196 |
| —fall plowing for..... | 206 | —removed by crop..... | 191, 196 |
| —to save..... | 394 | —taken from air..... | 194 |
| Montana experiment station, summer fallow at..... | 415 | Nodules | |
| Mops, labor-saving..... | 980 | —alfalfa..... | 116 |
| Mormons, crops saved..... | 750 | —soy bean..... | 136 |
| "Mother" beets..... | 133 | North Dakota experiment station, winter seed drifting..... | 637 |
| Moth | | Nubbin, cucumber..... | 799 |
| —brown-tail..... | 724 | Nursery, ordering trees from... 251, 256 | |
| —bud..... | 737 | Nuts, extra..... | 906 |
| —codling..... | 738 | Nuts, in cooking..... | 961 |
| —grain and flour..... | 45, 680 | Oak, white, red, black, for fence posts..... | 938, 949, 950, 951 |
| —grape berry..... | 717 | Oats | |
| —gypsy..... | 725 | —amount of water needed for.... | 392 |
| —trap..... | 46 | —as corn crop..... | 273 |
| Mould, gang..... | 525 | —as dry land crop..... | 408, 422 |
| Moulds, concrete (see Forms) | | —culture..... | 85-87 |
| Movable hog house..... | 553, 559 | —cultivation..... | 86 |
| Movable "A"-shaped house..... | 554 | —diseases of..... | 769 |
| Movable "shed-roof" house..... | 556 | —harvesting..... | 86 |
| Mulch | | —on alkali soil..... | 172 |
| —definite..... | 269 | —plant food removed by..... | 165 |
| —dirt..... | 394 | —rotations..... | 86 |
| —dust..... | 205 | —seed..... | 33 |
| —for stubble land..... | 402 | —seed-bed..... | 85 |
| —manure..... | 188 | —seeding..... | 85 |
| —sod..... | 268 | —smut in..... | 38 |
| Muriate potash | | —to distinguish from wild oat... 614 | |
| —cost of..... | 203 | —with millet..... | 623 |
| —potassium in..... | 203 | —with peas..... | 148 |
| Mush, to cook..... | 959 | Ohio experiment station..... | 939 |
| Muskmelon..... | 224 | Ohio swamp land..... | 363 |
| Mustard, wild..... | 616 | Oil meal, for stock food..... | 156 |
| —(plate)..... | 603 | Oil treatment, for fence posts... 944, 945, 949 | |
| Mutton | | Oils | |
| —cutting..... | 1162 | —for repair work..... | 907 |
| —dressing..... | 1160 | —to preserve timber..... | 943 |
| Nails..... | 906 | Oiler..... | 897 |
| Naked smut, wheat..... | 763 | Oil stove..... | 897 |
| Name plate..... | 496 | Oil stove, on a farm..... | 976 |
| Naphtha soap, use of..... | 992 | Olin, W. H. (quoted)..... | 434, 463 |
| Nasturtium, climbing..... | 240 | Onion..... | 222, 226 |
| Neck chains, for cows..... | 498 | —maggot, imported..... | 703 |
| Nellon, Mr. (quoted)..... | 608 | —juice, to extract..... | 966 |
| Nests, poultry..... | 564 | Orchard | |
| Nesting places, guide for..... | 761 | —care of trees before planting... 257 | |
| New York, as butter market.... 1065 | | —crops, diseases of..... | 788-795 |
| New York experiment station, orchard experiment..... | 276 | —cultivation of..... | 270, 277 |
| New York Mercantile Exchange..... | 1068-1069 | —fertilizing..... | 275 |
| Nickel, to clean..... | 967-969 | —grass, rust..... | 764 |
| Nippers, cutting..... | 906 | —laying out..... | 249 |
| Nitrogen, for orchards..... | 272-276 | —number of trees per acre in... 248 | |
| Nitrogen-fixing bacteria... 109, 110-136 | | —nursery orders for..... | 255 |
| —cultures of..... | 117 | —other crops in..... | 267-273 |
| Nitrogen, in soil | | —planting..... | 245, 259 |
| —amount..... | 165 | —pruning..... | 263, 277-284 |
| —cost of..... | 181, 202, 203 | —selecting trees for..... | 251 |
| —crop indications of..... | 164 | —services of birds in..... | 752 |
| | | —site of..... | 244 |

- | | Page | | Page |
|------------------------------------|---------------|-----------------------------------|--------------------|
| Orchard, soil | 244 | Perennials, herbaceous..... | 234, 236 |
| —soil management | 266-277 | Petunias | 238 |
| —top pruning | 263 | Phosphoric acid | |
| Organic matter | | —amount of phosphorus in..... | 162 |
| —added to soil..... | 194 | Phosphorus | |
| —in soil | 205 | —amount in soils..... | 165 |
| —increased by manure..... | 186 | —cost of..... | 181, 202, 203 |
| Organization, co-operative..... | 1082-1893 | —crop indications of..... | 164 |
| Ounce, approximate measures of... | 956 | —freed by lime..... | 172 |
| Outhouses, care of..... | 745 | —in manure; per cent losses from | |
| Outlets, drainage..... | 372 | | 180, 181-183 |
| Ox-eye daisy | 634 | —per cent in phosphoric acid.... | 162 |
| —(plate) | 620 | —removed by crops..... | 191 |
| Oyster-shell scale | 732 | Phlox annual | 238 |
| Packers, for dry farming..... | 419 | “Physics of Agriculture” referred | |
| Packing soil..... | 394, 397, 402 | to | 493 |
| Paint | | Pie crust, suggestions for making | |
| —to preserve timber..... | 942 | | 959-960 |
| —to remove | 967 | Pie tins | 982 |
| Paints and painting..... | 598-600 | Piers, concrete | 338 |
| Paints, for repair work..... | 907 | Pine, jack, for fence posts..... | |
| Palette knife, in kitchen..... | 981 | | 938, 949, 950, 957 |
| Palmer (quoted) | 425 | Pineapple corers | 978 |
| Pans, homemade rack for..... | 983 | Pinks | 238 |
| Pansy | 238 | Pipe fitting | 895 |
| Paper, uses in kitchen..... | 982 | Pipette, for milk testing..... | 1122 |
| Parers | 976 | Pistol case-bearers | 737 |
| Paris green | 653 | Piston | 813 |
| Parsley | 222, 226 | —badly worn | 859 |
| —storage of | 219 | —over-heated | 857 |
| Parsnips | 222 | —over-hauling | 870 |
| Pastry flour | 960 | Piston rings, worn..... | 858, 860 |
| Pastry fork | 979 | Pit, manure | 346 |
| Pasturage | 1041 | Pit silo | 528 |
| Pea | | Planes | 886 |
| —aphis | 691 | Plans | |
| —diseases of | 800 | —cattle barn | 536-538 |
| —garden | 224-226 | —combination barn | 543-546 |
| —sweet | 240 | —dairy barn | 481-484, 507 |
| —weevils | 148, 690 | —farmhouse | 472-480 |
| Peat land, drainage of..... | 382 | —granary elevator | 579 |
| Peat soil | | —hog house | 547, 550-553 |
| —composition of | 166 | —horse barn | 540 |
| —moss, as absorbent..... | 183 | —machine shed | 593 |
| —power to hold moisture..... | 206 | —potato warehouse | 552-588 |
| Pen | | —poultry house..... | 561, 571-573 |
| —bull | 499 | —root cellar | 590-591 |
| —calf | 500 | —sheep barn | 576 |
| Pennsylvania experiment station, | | Plant bug, tarnished..... | 701 |
| orchard experiment..... | 276 | Plant diseases (see Diseases) | |
| Penny cress | 613 | Plant food | |
| Pens for hog house..... | 551 | —elements of | 162 |
| —doors | 552 | —freed by lime..... | 172 |
| —farrowing | 552 | —in manure; amounts..... | 181, 185 |
| —fender for | 547 | —conservation | 183 |
| —overlay | 551 | —loss | 181-183 |
| Peppers | 223, 226 | —removed by crops..... | 165 |
| Percolator, coffee | 978 | —removed by 3-year rotation.... | 191 |
| Perennial | | —removed by farming | 192 |
| —definition of | 604 | —supplied by fertilizers..... | 201 |
| —sow thistle | 631 | —supplied by green manures.... | 201 |
| Perennial weeds, methods of eradi- | | Planting, plans for orchard..... | 246 |
| cation | 620-624 | Planting table, flower..... | 242 |

- | | Page | | Page |
|--|---------------|------------------------------------|--------------|
| Planting the commercial orchard | 243-265 | Potatoes, seed-bed..... | 124 |
| Plastering, concrete | 359 | —soil for | 122 |
| Pliers | 896 | —storage | 129 |
| Plowing | | Pound, approximate measures of... | 956 |
| —dry land | 396-404 | Poultry, killing and dressing..... | 1163 |
| —relation of depth to soil mois-
ture | 206 | Poultry house | 560-574 |
| —to kill weeds..... | 621 | —brooder | 573 |
| Plows for dry farming..... | 417 | —feeding and watering devices.. | 567 |
| Plum | | —incubator | 573 |
| —curculio | 727 | —location | 469 |
| —diseases | 793 | —long | 569 |
| —gouger | 728 | —movable | 570-574 |
| Point rot, tomato..... | 799 | —nests | 563 |
| Poisons for insects..... | 653 | —permanent | 561-570 |
| Pony refrigerators | 298 | —plans | 561, 573 |
| Poplar, for fence posts.... | 949, 950, 951 | —roosts | 563 |
| Poppy | | —yard | 569 |
| —annual | 238 | Powdery mildew | |
| —California | 238 | —bean | 799 |
| Pork, cuts | 1161 | —gooseberry | 797 |
| —dressing | 1147 | —grape | 798 |
| —salt | 1166 | —pea | 802 |
| Portable gas engine, uses of..... | 807 | Powell, G. H. (quoted)..... | 1084 |
| Portland cement | 306 | Power, gas engine, see horsepower | |
| Pot-holes, drainage of..... | 371 | Power house | |
| Potash | | —farm | 839-846 |
| —amount of potassium in..... | 162 | —equipment | 843 |
| —bichromate | 1122 | Pre-ignition | 827-854, 859 |
| —muriate | 203 | Preservatives, for meat..... | 1165 |
| Potassium | | Press drill | 396 |
| —amount in soils | 165 | Press, for foods | 979 |
| —cost | 181-203 | Price quotations | 1067-1069 |
| —crop indications of | 164 | Prior rights | 428, 448 |
| —freed by lime..... | 172 | Property, value | 1000 |
| —in manure, per cent, 180; losses | 181-183 | Proportions, in cooking | 956 |
| —percent in potash | 162 | Proso millet | 406, 411 |
| —removed by crops..... | 191 | Protection from lightning..... | 595-597 |
| —sulphate | 203 | Pruning | |
| Potato | | —bearing orchard | 277-284 |
| —beetle | 651 | —bush fruits..... | 295 |
| —eyers | 978 | —root | 260 |
| —stalk borer | 685 | —top | 263 |
| —warehouse (see warehouse) | | —tools | 282 |
| —water | 961 | —wounds from | 282 |
| Potatoes (culture) | 122-130 | Prussian bluing | 990 |
| —amount of water needed for..... | 392 | Pseudomonose, alfalfa | 787 |
| —as dry land crop..... | 411-422 | Public market | 1071 |
| —commercial fertilizers for..... | 123 | Pulleys | 843 |
| —cultivation | 126 | —speed and sizes | 845 |
| —cutting seed | 126 | Pumice stone, for shiny spots..... | 993 |
| —digger | 128 | Pumping plants, irrigation..... | 431 |
| —diseases of | 777-786 | Pumpkin | 224 |
| —harvesting | 128 | —storage | 219 |
| —hopper | 127 | Punches | 890 |
| —irrigation of | 461 | —leather | 898 |
| —manuring | 123 | Pure-seed laboratories | 628 |
| —planting | 124 | Quack grass | 625 |
| —rotations | 122 | —rust | 764 |
| —seed | 129 | Quicklime | |
| | | —cost | 175 |
| | | Quincunx planting system..... | 247 |
| | | Rack, outdoor feeding..... | 539 |

	Page		Page
Radishes	222, 226	Rhubarb	224, 226
—to keep fresh.....	969	Rhizoctonia, potato	782
Rag-doll test for seed corn.....	71, 72	Ribbon, to wash.....	993
Railroad worm	739	Rice weevil	45
Rainfall		Rivet set	898
—amount necessary for dry farm- ing	424	Riveting machine	898
—less than 20 inches.....	388	Rivets	
Range, kitchen	953	—harness	907
Rasp, wood	887	—iron	906
Raspberries (culture)	291-299	Roadside weeds	611
—cultivation	294	Roberts, quoted	181
—diseases	299-795	Rock phosphate, cost.....	202
—getting plants	293	Rodents, killed by birds.....	754
—harvesting and marketing.....	298	Roller	
—insect pests of	299, 710-714	—corrugated	81
—planting	292-294	—effect on soil moisture.....	394
—pruning and thinning.....	295	—to make	421
—soil for	292	Roof, curb, to brace.....	481
—tying, staking, trellising.....	296	Roosts	563
—types	291	Root cellar	589-591
—varieties	299	Root crops	
—winter protection	297	—effect of manure on.....	187
Ratoons	97	—vegetable	222
Rats and mice, to do away with...	968	Roots, interference with tile.....	376
Records, farm	997-1026	Rope and its uses on farm.....	909-936
—breeding	1008	—construction of	910
—cash accounts	1002	—halters	919
—crop yield	1008	—hitches	915
—egg	1008	—splices	926
—feeding	1011	—strength of	911
—household	1015	—to prevent untwisting	912
—inventory	998	—weight of	912
—labor	1010	Rosette, potato	782
—milk	1129	Rot	
—production	1005	—apple	790
—seeding	1016	—bean	799
—time	1012	—cabbage	800
Reclamation Act.....	427	—cherry	793
Rectangular planting system.....	246	—grape	798
Red clover, as green manure crop..	196	—plum	793
Red rust	763	—potato	785
Reed, A. C., quoted.....	748	—tomato	799
Reinforcing, concrete	323	—vegetable	802
—for silos	514, 521, 527, 534	Rose, Dorothy Perkins	241
Removal of weed seed, chaff and light-weight grain.....	27-31	Rose, chafer	716
Repair work	880-908	Rotation as a means of blight con- trol	41
—conveniences for.....	898	Rotation	
—materials for	904	—experiment at U. of Ill.....	1029
—paints and oils for.....	907	—for corn belt	1035
—shop equipment	902	—for dairy farm	1049
—suggestions	907	—for grain and hay farm.....	1030
—tools for	882	—for sheep farm.....	1040
Repellents	655	—plant food removed by.....	190
Replanning a farm for profit.....	1027-1056	—principle of	41
—dairy farm.....	1045	—to kill weeds.....	609
—grain and clover farm.....	1034	Rotations	44
—grain and clover seed farm.....	1032	—alfalfa	121
—hog farm	1042	—barley	88
—sheep farm	1036	—clover	113
Reservoirs		—corn	77
—irrigation.....	430, 431	—dry land	413
—loss of water in.....	434	—flax	152
		—oats	86

- | | Page | | Page |
|------------------------------------|-------------|-------------------------------------|-------------|
| Rotations, rye | 92 | Saw horses | 900 |
| —soy beans | 140 | Scab | |
| —to preserve humus..... | 414 | —apple | 789 |
| Round dairy barn | 502-507 | —potato | 785 |
| Rule | | —wheat | 768 |
| —folding | 887 | Scale | |
| —plumb | 888 | —oyster shell | 732 |
| Run (see surface ditch) | | —San José | 719 |
| Russian thistle | 617 | —scurfy | 733 |
| Rust | | Scales, milk | 1128-1133 |
| —apple | 791 | Screening (seed) | 31 |
| —barberry | 763 | Screen, to hold babies' belongings. | 984 |
| —barley | 764, 771 | Screw driver | 886 |
| —control of | 764 | Screws, wood | 906 |
| —flax | 775 | Scrubbing brush | 984 |
| —oats | 769 | Sea Island cotton | 103 |
| —on grasses | 764 | Seed | |
| —on wild barley | 635 | —amount required | 226 |
| —raspberry | 796 | —cane | 96 |
| —rye | 773 | —corn | 60 |
| —wheat | 762, 763 | —discoloration of..... | 33 |
| Rye (culture)..... | 91-92 | —diseased and weak, marks of... 33 | |
| —as cover crop | 273 | —inspection laws | 28 |
| —as dry land crop..... | 409, 422 | —light weight | 28-33 |
| —diseases of | 773 | —list for testing..... | 53 |
| —harvesting | 92 | —mixtures | 33 |
| —rotation | 92 | —plat, seed for..... | 74 |
| —seed-bed | 91 | —selection | 32 |
| —seeding | 91 | —smutted | 33-34 |
| —threshing | 46 | —testing | 28-53-66-72 |
| Sage brush cutter..... | 449 | —time table for test..... | 56 |
| Salad dressing | 966 | —to clean | 29-30-31 |
| Sale, method of | 1063, 1067 | —weed | 28 |
| Salpiglossis | 238 | Seeders | |
| Sales | | —for dry farming..... | 421 |
| —basis of | 1063-1064 | Seed-bed | |
| —commission | 1064-1065 | —for dry farming..... | 404 |
| —consignments | 1064 | Seed corn tarring..... | 757 |
| —delivered | 1065 | Seed corn maggot..... | 675 |
| —track | 1066 | Seed selection and storage..... | 27-57 |
| —contract | 1066 | Seeding diseases | |
| Salsify | 222-226 | —oats | 771 |
| Salt Lake City monument to gulls.. | 750 | —wheat | 768 |
| Salt, to keep from lumping..... | 966 | Seeding | |
| Salt, to kill weeds..... | 608-620 | —for dry land crops..... | 422 |
| Salvia | 238 | —for hot-bed | 215 |
| San Jose scale | 719 | —for garden | 216 |
| Sand, for concrete | 308 | Selection of seed | 32-33 |
| —bank | 309 | Separator, to wash..... | 967 |
| Sandy soil, drainage of..... | 370-373-374 | Septic tanks | 350 |
| Sandy soils | | Sleeve board | 986 |
| —composition of..... | 165 | Shed, open cattle | 539 |
| —movement of water in plowing | 398 | “Shed roof” hog house..... | 556 |
| —power to hold moisture | 206 | Sheep barn | 575-577 |
| —treatment of | 199 | Sheep farm | 1036 |
| Sausage | 1168 | Sheep, killing and dressing..... | 1160 |
| Sausage cooking hints..... | 957 | Sheep shank (Hutch) | 915 |
| Saw | | Shining spots, to remove from | |
| —compass, bracket..... | 885 | clothing | 993 |
| —hack | 894 | Shock, to build | 82 |
| —sharpening of | 884 | Shoes, to keep patent leather..... | 969 |
| Sawdust box best for corn..... | 66 | Short circuit | 853 |
| Saw-fly, raspberry | 712 | Shortenings, for pastry..... | 960-961 |

	Page		Page
Shot hole		Soil, loam	165
—cherry—Plum	795	—management	394-406
Shrubs, in dry farming	416	—moisture held by cultivation	206, 389-393
Sidewalks, concrete	328-329	—peat	166
Silage, corn and soy beans	140	—productivity factors	161-162
Silk waists, to wash	992	—sanitation of	768
Silver, to clean	967	—sandy	165, 199
Silos	508-535	—testing	166-170
—all wood	509	Soils and Soil Fertility	161-208
—capacity of	533	Soldering irons	894
—cement blocks	525	Solanaceous vegetables	223
—cement, wash for	525	Sorghum	
—comparison of	532	—as dry land crop	410
—concrete	527-535	—culture	93-95
—construction devices	517	—cultivation	94
—casts	533-535	—harvesting	94
—doors	513-520	—planting	93
—floors	510	—seed-bed	93
—foundation	509-520-527	—seedlings	422
—gurler	509-511	—soil for	93
—hoop	511	Sorrel, showing acid soil	167
—Iowa	516	Sour soil (see acidity of soil)	
—location	508	—to correct, for alfalfa	115
—pit	528	South St. Paul Daily Reporter, the	1068
—reinforcing for	514-521-527	Sow thistle	
—roofs	511-523-534	—annual	619
—for round-barn	502	—perennial	631
—size	509	Soy beans	
—solid concrete	527-535	—as cover crop	273
—stave	512-534	—cultivation	137
—tables for construction	532	—culture	135-140
—vitrified clay	516	—harvesting	138
—siphons	453	—inoculation	136
Slicers, various kinds	978	—planting	137
Small fruits, diseases of	795-798	—rotations	140
Smoke, meaning of in gas engines	860	—seed	135
Smoke house	1167	—seed-bed	135
Smoking meat	1167	—storage	140
Smother crops, for weeds	622	—value of	135
Smut	34	Spark, timing of	826, 853
—barley	771	Sparrow, English	749, 753, 757
—corn	776	Spatula, in cooking	981
—grain crops	762	Special Pointers on Crops	60-156
—oats	770	—alfalfa	114
—rye	773	—barley	88
—wheat	765	—Canadian field peas	146
Snap dragon	238	—clover	199
Snips, tanners	896	—corn	60
Snyder (quoted)	206	—cotton	100
Soap, home-made	987	—field peas	146
Soap shaken	983	—flax	150
Sod mulch	268	—oats	85
Soda, uses in cooking	966	—potatoes	122
Sodium nitrate, cost	202	—rye	91
Soft rot, vegetables	763, 802	—sorghum	93
Soil		—soy beans	135
—acidity	166-169, 172-179	—sugar beets	131
—alkali	171-172	—sugar cane	96
—alkalinity	166-170	—timothy	141
—analysis of	163	—wheat	78
—clay	165	Specific gravity, scale	831
—composition of	161-166	—table	830
—fertility of	162		
—elements for plant growth	162-163		

- | | Page | | Page |
|--|------------|---|--------------------|
| Speculation, in wheat..... | 1077-1081 | Strawberries, renewing bed..... | 289 |
| —evils of..... | 1081 | —varieties..... | 290 |
| Speltz..... | 409 | —winter protection..... | 289 |
| —seeding..... | 422 | Straw-worm, wheat..... | 672 |
| —with corn..... | 408 | Streams for irrigation..... | 430 |
| Spice, in cake..... | 961 | Stripe disease, barley..... | 773 |
| Spinach..... | 222, 226 | Sub-irrigation..... | 455 |
| Spliced crown..... | 913 | Sub-soil, acid..... | 401 |
| Spliced eye..... | 934 | —ground seams in..... | 390 |
| Splices..... | 926 | Subsoiling..... | 400 |
| —long..... | 929 | Sub-surface drainage..... | 370-378 |
| —short..... | 926 | Sudan grass, as intertilled crop, cul-
ture..... | 413-422 |
| —spliced eye..... | 934 | Sugar, beet..... | 963 |
| Spokeshave..... | 887 | Sugar beet | |
| Spoons, best kind for..... | 981 | —amount of water needed..... | 392 |
| —for jelly making..... | 962 | —cultivation..... | 132-133 |
| Spraying..... | 788 | —culture..... | 131-134 |
| —for weeds..... | 607, 620 | —harvesting..... | 133 |
| —orchards..... | 284 | —seed..... | 133 |
| Springs, for irrigation..... | 430 | —seed-bed..... | 131 |
| Spruce for fence posts..... | 949, 951 | —seeding..... | 131 |
| Spud for weeds..... | 607 | —testing..... | 133 |
| Square, bevel, steel..... | 885 | —thinning..... | 132 |
| Squash..... | 224-227 | Sugar cane (culture)..... | 96-99 |
| —bug..... | 698 | —cultivation..... | 98 |
| —storage..... | 219 | —fertilization..... | 96 |
| Squeezers, lemon and orange..... | 982 | —harvesting..... | 98 |
| Squirt-can..... | 897 | —planting..... | 97 |
| Staging for silo..... | 517 | —seed cane..... | 96 |
| Stains, instructions for removing..... | 987-989 | —soil preparation..... | 97 |
| Stalk-borer, potato..... | 685 | —soils for..... | 96 |
| Stalls | | Sulphur, to fumigate with..... | 47 |
| —box..... | 542 | Sulphuric acid, for milk testing..... | 1123 |
| —dairy barn..... | 495-499 | Summary of information useful in
recognition of weeds..... | 642-647 |
| —for round barn..... | 506 | Surface ditch..... | 384-387 |
| Stanchions (see Stalls) | | Surface drainage..... | 370, 384-387 |
| Staple puller..... | 897 | Surface run (see Surface Ditch) | |
| Staples..... | 906 | Surveying, for drainage system.... | 366 |
| Starch, to prepare..... | 991 | Surveyor's level (see Leveling
Instrument) | |
| Stave silo..... | 512, 534 | Sweaters, to wash..... | 992 |
| Steam cooker..... | 976 | Sweating | |
| Stem rot, bean..... | 799 | —barley..... | 89 |
| Step ladder, in the kitchen..... | 979 | —grain..... | 51 |
| Steps, concrete..... | 353 | Sweeping, hints for..... | 968, 969 |
| Stink weed..... | 613 | Sweet clover, as green manure crop
..... | 197-198 |
| Stinking smut, wheat..... | 34, 765 | Sweet pea..... | 240 |
| Stock, feed requirements..... | 1031, 1037 | Tachina flies..... | 652, 661 |
| Stock foods, danger from..... | 156 | Tamarack, for fence posts
..... | 938, 949, 950, 951 |
| Stool, in kitchen..... | 980 | Tangle foot, tree..... | 655 |
| Storing grain..... | 50 | Tanks, concrete | |
| Storing vegetables..... | 218 | —septic..... | 350 |
| Stove lid, sectional..... | 982 | —water..... | 342 |
| Stucco, concrete..... | 359 | Tar paper, to kill weeds..... | 606 |
| Strainer holder..... | 979 | Telephone companies | |
| Straw, manure, precaution in use of..... | 44 | —co-operative..... | 1093 |
| Strawberry, insects injurious to..... | 705, 709 | Ten commandments of dry farming..... | 425 |
| Strawberries and bush fruits..... | 286-302 | Tent caterpillar..... | 735 |
| Strawberries (culture)..... | 286-291 | Test plat, clonal..... | 144 |
| —leaf spot..... | 797 | —potatoes..... | 123 |
| —location..... | 287 | | |
| —picking and marketing..... | 290 | | |
| —planting..... | 287, 288 | | |
| —propagation..... | 286, 290 | | |

- | | Page | | Page |
|-------------------------------------|----------|--|---------------|
| Testing seeds for germination..... | 53 | Treatment to Exterminate Insects | |
| Thermometer, use in churning..... | 982 | from Grains | 45 |
| Thistle, Canada..... | 628 | Tree-cricket, snowy | 711 |
| —Russian | 617 | Tree-hopper, buffalo | 721 |
| Thread, cutting | 895 | Trees | |
| Three-port engine | 820 | —effect of manure on..... | 188 |
| Thumb tacks, for oil cloth..... | 969 | Trench (drainage) | |
| Tile | | —cost of digging..... | 379 |
| —costs | 379 | —digging and grading..... | 374 |
| —depth | 373 | —filling of..... | 377 |
| —laying | 375-376 | Triple kettles, use..... | 973, 974 |
| —protection of | 372 | Troughs, concrete | |
| —size of..... | 373 | —hog | 344, 559 |
| Tillage, dry farming..... | 394-406 | —water | 342 |
| —before fallow | 401 | Trouvelot, Prof..... | 725 |
| —deep | 400 | Tumble weed (sec Russian Thistle) | |
| —inter- | 404 | Turkeys, dressing | 1163 |
| Timber | | Turnips | 222, 226 |
| —preserving of | 941 | Two-bag batch, concrete..... | 313 |
| —seasoning of | 939 | Two-cycle engine | 818 |
| Time sheet, worker's daily..... | 1012 | —differences from three-port.... | 821 |
| Timothy (culture)..... | 141-145 | United States | |
| —clonal test plat..... | 144 | —arid land | 388 |
| —harvesting | 143 | —bird population | 757 |
| —improvement of | 144 | —Forest Service | 950 |
| —manures | 142 | —insect loss..... | 748 |
| —mixtures | 142 | United States Department of Agri-
culture | |
| —plant food removed by..... | 165 | —bacteria cultures | 117 |
| —seed-bed | 141 | —pure seed laboratories | 628 |
| —soil for | 141 | Utah experiment station | |
| —sowing | 141 | —dry farming demonstrations... .. | 389 |
| —time to cut..... | 143 | Vacuum cleaners, advantages..... | 975 |
| —weed seed in..... | 634 | Valves, gas engine | |
| Tins, coffee | 959 | —leaky | 857 |
| Tip burn, potato | 780 | —worn | 860 |
| Tobacco | | Van Slyke (quoted)..175, 180, 185, 200 | |
| —effect of manure on..... | 187 | Vat, milk and cream, concrete.... | 345 |
| —to poison insects..... | 654, 655 | Vegetable garden | 211-227 |
| —worm | 741 | —amount of seed to sow | 226 |
| Tomatoes | | —cultivation | 213 |
| —culture | 223, 227 | —diseases | 220 |
| —diseases of | 799 | —fertilizers | 212 |
| —to ripen indoors | 969 | —insects | 220 |
| Tongs | 892 | —location | 211 |
| Toolrack, kitchen, home-made.... | 983 | —planning | 215 |
| Tools | | —seeding | 216 |
| —blacksmithing | 902 | —soil | 212 |
| —care of | 903 | —tools for | 213 |
| —combination outfits | 900 | —transplanting | 218 |
| —drainage | 375 | —value of | 211 |
| —for concrete | 326 | —weeds in | 218 |
| —for gardening | 213 | Vegetables | |
| —harness repair | 898 | —amount of seed required..... | 226 |
| —iron working | 888 | —canning | 220, 965, 966 |
| —miscellaneous | 896 | —cole crops | 222 |
| —purchase of..... | 882 | —diseases of | 220, 798-802 |
| —value of listing..... | 1001 | —foliage crops | 222 |
| —wood working | 883 | —hardy | 220 |
| Towel holder, simple device for.... | 983 | —insects | 220 |
| Toxic alkalis | 171 | —legumes | 224 |
| Transpiration, definition of..... | 391 | —perennial | 224 |
| Transplanting | 218 | | |
| Treatment of seed for smut..... | 34 | | |

- | | Page | | Page |
|-------------------------------------|---------------|-------------------------------------|------------------|
| Vegetables, root crops..... | 222 | Weeds | 603-645 |
| —soft rot..... | 802 | —annual, to eradicate..... | 606-611 |
| —solanaceous crops | 223 | —biennial, to eradicate..... | 606-611 |
| —storing | 218 | —descriptions of, | |
| —tender | 220 |613-619, 625-635, 642-647 | |
| —vine crops | 224 | —in garden | 218 |
| Vegetations | | —perennial | 620-624 |
| —birds to protect (table)..... | 760 | —propagation | 604 |
| Ventilation | | —roadside | 611 |
| —King system of..... | 485-494 | —spread of | 603, 636-641 |
| —for round barns..... | 504 | —summary to identify..... | 642-647 |
| Verbena | 238 | —troublesome | 613-619, 625-635 |
| Vetch, Dakota | 413 | Weedy Land, conditions which tend | |
| —seeding | 422 | to bring about | 636-641 |
| Vetch | | Weevils | |
| —hairy, for cover crop..... | 272 | —bean | 691 |
| —green manure crop..... | 198 | —boll | 741 |
| Vines, flowering | 240 | —clover leaf..... | 682 |
| Vise | 892, 896 | —grain | 679 |
| Vitrified block to test..... | 516 | —pea | 690 |
| Vitrified clay block silo..... | 516 | —strawberry | 708 |
| Walls | | Weights and measures..... | 954, 956 |
| —concrete | 340 | Weirs | 441-446 |
| —to clean | 968 | Weir boxes | 442 |
| Walnut, black, for fence posts..... | 938 | Weir boards | 443 |
| Warehouse, potato | 581-588 | Well-pipe hitch..... | 917 |
| —plans | 582 | Wells, for irrigation water..... | 432 |
| Washing machines | 985 | Whale oil soap..... | 654 |
| Washing of soil..... | 208 | Wheat, amount of water needed for | |
| Washington Bulletin | |392-393 | |
| —directions for picking raspber- | | —as dry land crop..... | 407, 422 |
| ries | 298 | Wheat (culture)..... | 78-84 |
| Washington, D. C., weed seed ex- | | —cultivation | 81 |
| periment | 753 | —diseases | 763 |
| Waste ditches | 454 | —fertilizers | 82 |
| Water, soil | 389-393 | —harvesting | 82 |
| Water, to soften hard..... | 966 | —insects injurious to..... | 669-673 |
| Water for irrigation | | —loose smut..... | 38 |
| —amount to use..... | 438 | —plant food removed by | 165 |
| —distribution of | 452, 455 | —prices | 1075-1080 |
| —duty of | 428, 429, 437 | —rotations | 83 |
| —formula for computing flow..... | 446 | —seed | 79 |
| —losses of | 434-438 | —seed-bed | 78 |
| —measurement | 439-447 | —smut | 34-38 |
| —rights | 427, 428, 439 | —soils for..... | 78 |
| —sources of | 430-433 | —sowing | 79-80 |
| —standards of measurement..... | 439 | —sterilizing smut | 34 |
| —value of | 428 | —threshing | 46 |
| Water glass, for eggs..... | 965 | —Winter, time to plant..... | 671 |
| Water jacket, cracked..... | 864 | Wheel tray | 953 |
| —to clean | 870 | Whipping of rope..... | 912 |
| Watermelon | 224, 227 | Whirling machine | 1124 |
| Watering system | | White grubs | 657 |
| —drinking cup | 494 | White wash, to preserve timber..... | 942 |
| Watering trough, location of..... | 469 | White weed | 634 |
| Webster, F. M., quoted..... | 671, 672 | Widtsoe, J. A., quoted..... | 392, 393, 415 |
| Web-worm— | | Willow, white, for fence posts..... | 938, 949, 951 |
| —sugar beet | 693 | Wilt— | |
| —fall | 723 | —alfalfa | 787 |
| Weed Seed | 28 | —clover | 787 |
| —consumed by birds..... | 753 | —cucumber | 799 |
| Weeders for dry farming..... | 419 | —flax | 151, 775 |
| | | —potato | 751 |
| | | Wind break for sorghum..... | 93 |
| | | Winter wheat, time to plant..... | 671 |

	Page		Page
Wire, to straighten.....	522	—cabbage	694
Wire stretcher	897	—canker	726
Wire worms	658	—corn ear	677
Wild mustard	618	—corn root	675
—plate	603	—currant	713, 714
Wild oats	614	—railroad	739
Wisconsin bulletin—		—tobacco	741
—damage of excessive water.....	364	—wheat joint	672
Wisconsin Experiment Station—		—wheat straw	672
—hog house	547	Worms, to kill in dirt.....	969
—method of survey.....	366	Wounds, from pruning.....	282
—price of tile.....	379	Wrenches	889
—weed seed count.....	610	Wyoming Experiment Station.....	941
Wisconsin, Superintendent of Weights and Measures	1136	Xanthorhiza	241
Wisconsin, swamp land.....	363	Yellows—	
Wood horse-tail, showing acid soil... 168		—cabbage	800
Wood-working, tools for.....	888	—raspberry	796
Work bench	899	Zinc, chloride, for fence posts.....	942
Work shop, plan of.....	902	Zinnia	238
Worm—			
—army	660		

LIBRARY OF CONGRESS



0 003 190 628 3