

A



R 652

Technical Report

**FEASIBILITY STUDY AND COMPARATIVE
ANALYSIS OF DEEP OCEAN LOAD
HANDLING SYSTEMS**

December 1969



Sponsored by

NAVAL FACILITIES ENGINEERING COMMAND



NAVAL CIVIL ENGINEERING LABORATORY

Port Hueneme, California 93041

This document has been approved for public release and sale; its distribution is unlimited.

TA
417
IN3
no. R652

JAN 7 1970

FEASIBILITY STUDY AND COMPARATIVE ANALYSIS OF DEEP OCEAN LOAD HANDLING SYSTEMS

Technical Report R-652

YF 38.535.003.01.007A

by

D. A. Davis and M. J. Wolfe

ABSTRACT

Nine candidate systems for lowering and raising negatively buoyant loads in the deep ocean were compared and evaluated by means of a systems effectiveness model. For both load ranges considered — 20 to 100 tons and 400 to 600 tons at 6,000 feet — a lift system employing a ship with pipe string suspension medium was considered to be the most feasible approach.

Accurate positioning of heavy modular loads can be most readily achieved by resorting to acoustic devices for guiding the translation and rotation of the surface support craft prior to final emplacement. A manned submersible would serve as a useful guidance backup system.

The transport of 10- to 30-ton loads for short distances in the near bottom environment is considered feasible. Final choice between two competing systems, a heavy-life submersible and a hydrocopter, must await further definition of work missions and load configurations.

This document has been approved for public release and sale; its distribution is unlimited.

Copies available at the Clearinghouse for Federal Scientific & Technical Information (CFSTI), Sills Building, 5285 Port Royal Road, Springfield, Va. 22151

CONTENTS

	page
INTRODUCTION	
OBJECTIVE OF STUDY	1
SCOPE OF STUDY	3
MISSION PROFILE	3
LIFTING AND LOWERING SYSTEMS	
CANDIDATE SYSTEMS	6
Conventional Surface Craft	6
Unconventional Surface Craft	9
Surface Independent	10
BACKGROUND	12
Surface Vessels	13
Pipe	16
Cable	24
Buoyancy Systems	27
OPERATIONAL ANALYSIS	30
Environmental Factors	30
Figures of Merit	31
Accountable Factors	31
Effectiveness Comparisons	32

MBL/WHOI



0 0301 0040406 7

	page
Availability Vector	33
Dependability Matrix	34
Capability Matrix	34
Heavy-Lift Analysis	35
Selection of the Figures of Merit	39
Costs	42
Systems Descriptions	43
Results and Conclusions	43
POSITIONING AND GUIDANCE OF LOADS	
DIVERCON I – A TEST CASE	49
MOTIVE SYSTEMS	52
Winches	52
Bottom Crawler	54
Submersibles	60
Displacement/Rotation of Surface Craft	61
ALIGNMENT SYSTEMS	63
Underwater Lighting	63
Underwater Television	64
Underwater Lasers	64
Guidelines	64
Acoustic Devices	66

	page
CONCLUSIONS	68
NEAR BOTTOM TRANSPORT SYSTEM	
PERFORMANCE CRITERIA	72
HEAVY-LIFT SUBMERSIBLE	74
Conceptual Design for a Helium Deballasting Vehicle	76
Conceptual Design for a Hydrazine Deballasting Vehicle	78
Conceptual Design for a Vehicle With Rigid Lift Tanks	79
Conclusions	79
HEAVY-LIFT BOTTOM CRAWLER	81
HYDROCOPTER	82
Conceptual Design	82
CONCLUSIONS	86
CONCLUSIONS	
LIFTING AND LOWERING	88
POSITIONING AND GUIDANCE	88
NEAR BOTTOM TRANSPORT	89

APPENDICES

A – SURFACE VESSELS 90

B – PIPE STRINGS. 103

C – CONCEPTUAL DESIGNS FOR CANDIDATE NEAR
BOTTOM TRANSPORT SYSTEMS 139

REFERENCES

INTRODUCTION

OBJECTIVE OF STUDY

The installation of offensive and defensive weapon systems on the sea floor will require a capacity for lowering, raising, and accurately positioning heavy, negatively buoyant loads. Loads envisioned are largely speculative at the present time but could conceivably consist of large concrete foundation blocks, nuclear reactor power stations, and structural steel frameworks, as well as a host of construction work subsystems: bottom crawling survey vehicles, dredgers and trenchers, and bottom-based load handling equipment, to name but a few.

The handling of buoyant loads or slightly negative, massive loads is not the subject of this report. This type of load — the prime example of which is the one atmosphere manned module or station — will most likely be implanted by the now thoroughly discussed winch-down technique. Safety for the human occupants dictates this implantment mode.

The authors used the Deep Ocean Technology Project Technical Development Plan (DOT TDP) as a guide in conceptualizing and evaluating candidate lifting, transporting, and positioning subsystems. The DOT TDP requirements are summarized in Table 1.

In the course of the study, the authors concluded that some of the TDP requirements such as the rate of lift, for example, should be relaxed somewhat while others, particularly the incidence of dynamic stresses in the load suspension system, were perhaps overstated. The authors, however, did not question nor modify the requirements for a 20- to 100-ton lift capability by FY-73 and a 400- to 600-ton lift capability by FY-77. Statements and conclusions concerning the shape, bulk, and weight of future loads are necessarily qualified by the present uncertainty as to their configuration.

Table 1. Desired Characteristics of the Lifting, Transporting, and Positioning Subsystem

Characteristic	Target Date	
	By FY-73	By FY-77
Surface-Support Subsystem		
Depth	6,000 ft	6,000 ft
Load Capacity	20-100 tons	400-600 tons
Rate of Lifting	1-3 fps	2-4 fps
Maximum Dynamic Stress in Cable (percent of static stress)	10-50%	5-10%
Maximum Vertical Oscillation of Object	1-2 ft	0.1-1.0 ft
Near Bottom Transport Subsystem		
Depth		6,000 ft
Load Capacity		10-30 tons
Height of Lift		20-100 ft
Transport Capability		300-600 ft
Alignment Tolerance (translation)		$\pm 0.1-0.5$ ft
Alignment Tolerance (rotation)		$\pm 1-3$ deg
Attitude Tolerance (vertical)		$\pm 1-3$ deg

SCOPE OF STUDY

The main body of the report is subdivided into five principal sections. The first three sections contain a discussion of nine candidate load lifting/lowering systems, and form the bulk of the report due to the accessibility of the raw data and experience record. Both load ranges, 20 to 100 tons and 400 to 600 tons, are given consideration. Mission profiles and systems descriptions are included and, where pertinent, appendixes are referenced. A relatively simple systems effectiveness model has been used herein as an aid in optimizing the choice(s) for the most feasible system(s). The model is described, the relevant operational parameters are discussed in detail, and the results of the model presented in tabular form.

Load positioning and guidance is considered separately from the task of lowering very heavy loads to the sea floor. The fourth section of the report is addressed to this problem. Unlike the previous case for lifting and lowering systems, however, no formal systems modeling was attempted due to the paucity and uncertainty of the available data.

The DOT TDP suggests that a Near Bottom Transport Subsystem (NBTS) would prove to be a useful auxiliary to a surface-supported, heavy-lift system. Thus the fifth and final section of the report attempts to define an NBTS mission profile as well as conceptualizing and comparing several candidate NBTS vehicles.

MISSION PROFILE

If one were to speculate on the mission profile for the first generation of large underwater systems, it seems logical to suppose that most units would be self-contained and require only one lift. The Manned Underwater Station designed by General Dynamics or a nuclear reactor are examples of loads which possess this self-contained characteristic.

The mission profile may best be described if the goals of the project are stated:

1. Transport an underwater structure of up to 600 tons from a port to a specified location at sea.
2. Place the underwater unit on the sea floor.
3. If necessary, monitor, control, and service the unit.

4. Retrieve the unit at a later date.
5. Return the unit to port.

These goals establish the major functions of the system and serve as a useful frame of reference for system conceptualization.

In an effort to provide an objective assessment of future underwater technology, the scenario discussed above, i.e., that of transporting, placing, and later retrieving one self-contained load, is based on projections of near-term installations. It is felt that as experience increases in placing this type of load, the task of assembling multipart, module-type loads will be closer to the realm of possibility; and the operational techniques and procedures for fulfilling the more complex task of assembly will be designed on a more knowledgeable and experienced basis than is presently possible.

Since it is highly probable that there will be a transition from single-unit loads to modular construction, an investigation of the latter is necessary for accurate definition of future problem areas. It is, therefore, considered essential to discuss the problems of transporting, guiding, and positioning loads once they are on the sea floor. Systems performing these tasks will follow a more advanced scenario than the single lift-or-lower operation:

1. Transport or receive from auxiliary vessels the components (modules) of an underwater structure.
2. Place and assemble the modular units on the ocean floor.
3. If necessary, enable the completed structure to be monitored, controlled, and serviced.
4. Disassemble and retrieve the units at a later date.
5. Transport (or transfer) the units to a port (or auxiliary vessels).

The primary differences between this and the first scenario are:

1. The more advanced system should be capable of receiving and transporting loads from auxiliary vessels at sea.

2. The system or an associated subsystem would be necessary to transport, guide, and accurately position the load once it is on the bottom.

The attributes, capabilities, limitations, and liabilities of techniques proposed for accomplishing these two functions are analyzed in the sections to follow.

LIFTING AND LOWERING SYSTEMS

CANDIDATE SYSTEMS

There are nine primary system configurations given consideration in this study:

1. Hydrodynamic winch
2. Platform and pipe
3. Ship and pipe
4. Platform and cable
5. Ship and cable
6. Free ascent/descent
7. Winch-down
8. Ship with buoyant assist
9. Platform with buoyant assist

During the course of the analysis some of these basic systems were modified by the addition of a subsystem. In general, however, the nine basic solutions to the problem form the core of the entire report.

Figure 1 gives an overall view of how the solutions are categorized. Three basic approaches to handling heavy loads at sea were conveniently defined on the basis of the support vessel(s) involved; these are: (1) conventional surface craft, (2) unconventional surface craft, and (3) surface independent.

Conventional Surface Craft

The most frequently proposed heavy-lift systems are those employing either a ship or a self-propelled platform which is used as surface support for suspending the load. Two suspending mediums, pipe and cable, are investigated in this report. Hence, there are four possible configurations for the conventional surface craft category:

1. Ship with cable
2. Ship with pipe string
3. Platform with cable
4. Platform with pipe string

These systems are illustrated schematically in Figure 2.

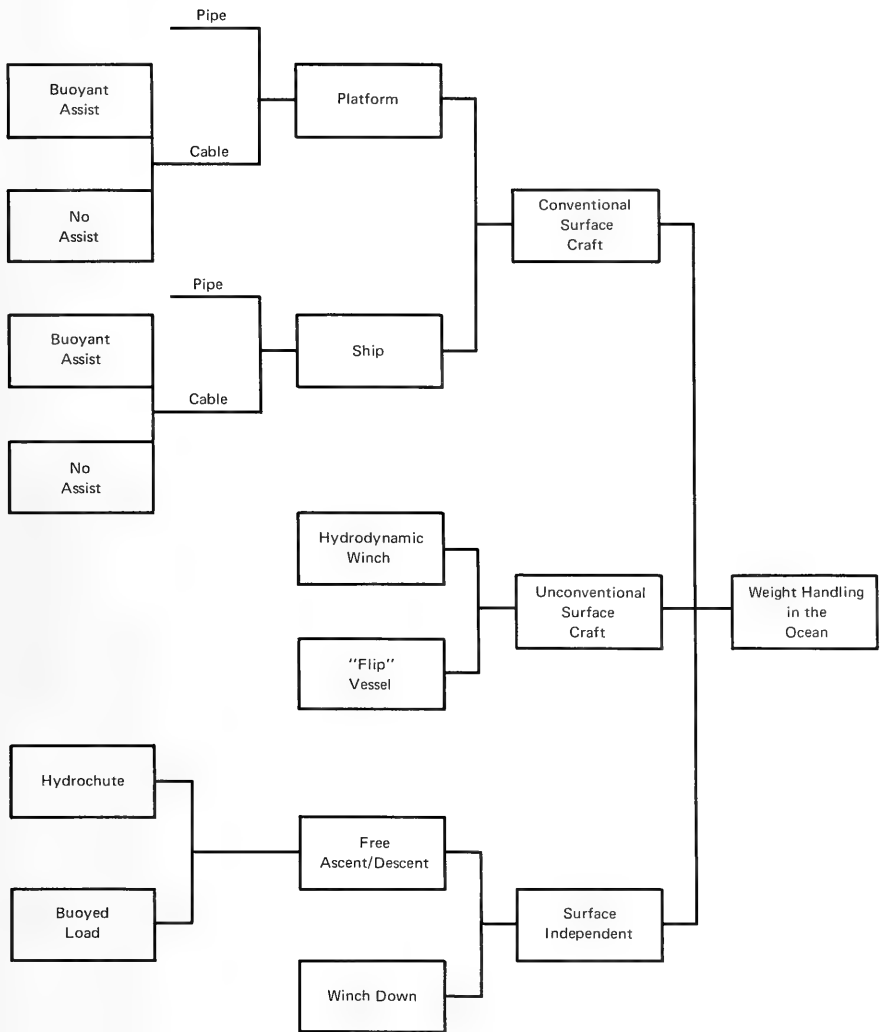
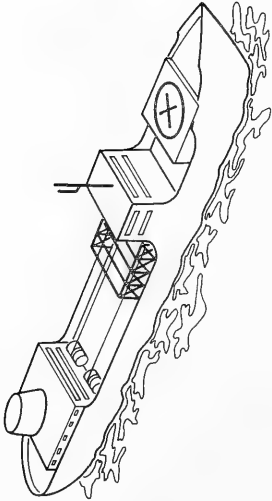
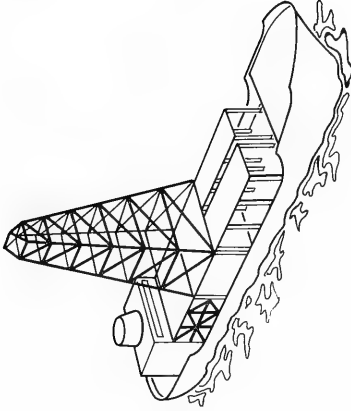

Figure 1. Candidate load handling systems.



(a) Ship with cable.



(b) Ship with pipe string.

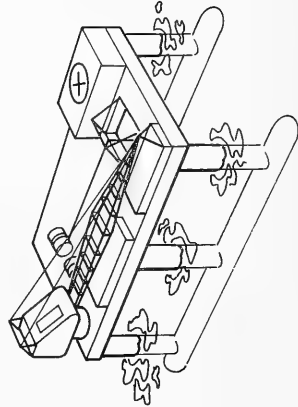

(c) Platform with cable.

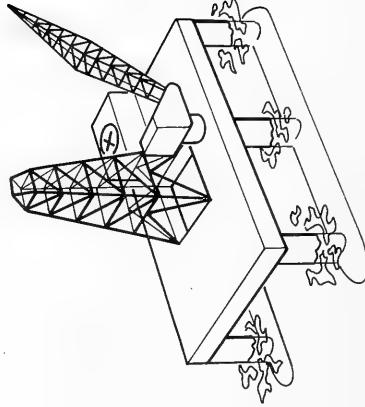

(d) Platform with pipe string.

Figure 2. Surface support vessels employing cable or pipe string as the load suspension medium.

There are, basically, no differences in the equipment or operational procedures among the systems using cable nor among the systems using pipe. It was assumed that the pipe handling equipment on the ship with pipe string, for instance, is exactly the same as that on the platform with pipe string. Thus, the differences between systems employing the same suspending medium are confined to the differences between surface vessel characteristics and the effects of these characteristics on system performance.

Operational procedures for these systems follow the tried and proven methods for lifting and lowering heavy loads. For the systems using cable, the load is suspended on one or more cables and lowered to the desired depth. In both the platform and ship it is assumed that a centerwell, amidships and open to the sea, is provided. No crane-type operations employing cable are investigated since the use of a boom was determined to be highly undesirable. In addition to the cable, all aspects of the winches, sheaves, and associated operations during usage are given careful scrutiny to determine the feasibility and desirability of utilizing cable on a ship or platform to satisfy the needs of the proposed heavy-lift system.

The operation of a system using pipe to support the load is very much the same as for cable. The same basic surface vessel is stipulated, i.e., one with a centerwell, but a single pipe is used to support the load. Moreover, there are the obvious additions of a derrick and the accompanying pipe handling equipment. The basic configuration is identical to that of the current fleet of mobile offshore drilling rigs. *Cuss I* is an example of this type of pipe system installed on a ship-like vessel, and the ill-fated MOHOLE platform exemplifies what is meant by "platform with pipe string" in this study. All facets of constructing and operating a system using pipe as the supporting medium are given consideration in the sections to follow.

Buoyant Assist. During the course of the study it was found highly desirable, if not necessary, to decrease the total load in the cable systems. Therefore, an external means of increasing the buoyancy of the load, thereby decreasing the total tensile force in the cable(s), is considered an important subsystem in the ship/cable and platform/cable systems. Various methods of providing this buoyancy are investigated. Cable systems employing these methods are said to have "buoyant assist."

Unconventional Surface Craft

Of the unconventional surface-supported systems, the hydrodynamic winch is given the most attention in this report.^{1,2} The hydrodynamic winch consists of a very large cylinder the interior of which is divided into

compartments by radial bulkheads. Water ballast is pumped between the compartments, subjecting the cylinder to a moment, and thereby forcing it to rotate. Wire rope lines attached to the cylinder wind around it as it is turning. The system is illustrated in Figure 3.

A second type of unconventional surface craft is patterned after the "Flip" vessel used by the Navy to test sonar. It is discussed briefly.

Surface Independent

The surface independent systems are virtually free of surface support during operation. Two basic concepts of surface independent systems are investigated in this report: (1) free ascent/descent and (2) winch-down.

Free Ascent/Descent. Free ascent/descent techniques are characterized by the need for slight negative buoyancy during descent and slight positive buoyancy during ascent. Two candidates of this category are considered in this study: (1) the hydrochute and (2) the buoyed load.

The hydrochute is simply an underwater parachute. It is attached to the load and the entire assembly is released. The chute provides enough drag to slow the load to an acceptable terminal velocity.

In the buoyed load concept, the negative buoyancy of the load is compensated for by a buoy system. The buoy system, which may or may not be expendable, can be adjusted for a calculated amount of lift for descent (slightly negative) or ascent (slightly positive) based on the permissible accelerations to which the load and/or buoys may be subjected. Only the buoyed load concept is considered in the systems effectiveness analysis.

Winch-Down. An excellent example of the winch-down concept is the Manned Underwater Station proposed by General Dynamics.³ In this system, the load, which is slightly buoyant, pulls itself down a cable anchored to the bottom. A winch mounted on the load provides the power for the lowering process. If need be, the load can be made positively buoyant by adding buoys of suitable size and characteristics.

The candidate systems are discussed in much greater detail in the following pages. The merits and liabilities of candidate subsystems common to all of the basic lifting and lowering systems are also discussed.

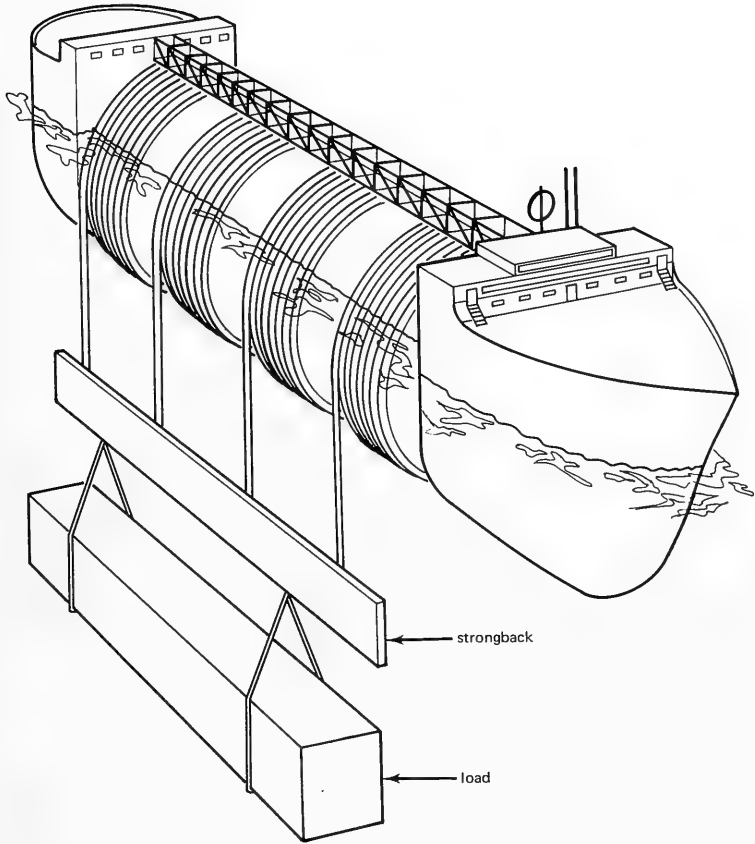

Figure 3. Hydrodynamic winch.

BACKGROUND

The first stages of the investigation included a comprehensive assessment of currently operating heavy-lift systems in the light of the TDP requirements. Nearly 20 past, present, and planned lifting/lowering systems were given careful consideration.⁴

It is clear that firms engaged in underwater construction and related fields expect no extreme departures from conventional methods of lowering loads into the ocean within the TDP time frame or even beyond. A good example of what is planned is the Alcoa *Seaprobe*, an all aluminum vessel which will be capable of lowering, via pipe string, loads of up to 200 tons to 6,000 feet — perhaps by 1972.⁵ The *Glomar Challenger*, a recently developed and constructed ship, will lower loads of at least 200 tons to unspecified depths in the very near future.⁶

Since industry-related development is based on extensions of past experiences, the tendency of the task team was to follow similar lines of thinking. It was assumed at the outset of the project, and subsequently affirmed, that most of the investigative effort should be concentrated on assessing the possibilities of extending the more tradition-based systems to meet the design criteria. However, sufficient time and study were given to the more novel solutions to adequately specify their respective problem areas and assets. Always kept in mind was the limited potential for more than nominal hardware development if the TDP schedule was to be met. Consequently, any technological potentialities were carefully considered to assure that only realistic predictions of future developments were utilized in the cost/effectiveness evaluations.

It can be seen that any one of the candidate systems previously discussed is actually a synthesis of component elements common to other systems. For example, cable is a component of the ship/cable, platform/cable, and hydrodynamic winch lift systems. The feasibility of these systems is primarily dependent on the feasibility of using cable. Similarly, adding buoyancy to the cable systems (buoyant assist) or to the loads in the free ascent/descent concept (buoyed load), produce systems which basically possess the same degree of feasibility; that is, the problems of one are the problems of the other. While there are differences among the systems, they will be accounted for in a more refined analysis; at present the concern is only with "basic feasibilities." Thus, the relative feasibilities of a large number of possible system configurations can be adequately determined by carefully specifying the limits and attributes of their common components.

The chosen approach entails consideration of common relevant factors and combinations of these factors. Inherent in this technique is the need for bounding the problem, i.e., limiting the number of alternatives. After gathering and weighing evidence during the initial stages of the project, it was found that familiarity with the following four subject areas would permit meaningful evaluations of virtually all the candidate systems:

1. Surface vessels
2. The use of pipe to suspend the load
3. The use of cable to suspend the load
4. Methods of supplying buoyancy to the load

The task team was organized to locate relevant technical and environmental data needed to carefully analyze these four subjects. When necessary, calculations were made in enough detail to answer specific questions on the effects of environment and similar factors on system performance.

Surface Vessels

All candidate heavy-lift systems require a surface vessel in some form. For ease of distinction, two types of surface craft are considered: platform and ship. Platforms are characterized by their very deep drafts when in the operational mode, while for ships most of the hull is near the water surface.

Five representative surface craft were investigated for their suitability as a component in the heavy-lift system. The dimensions and cost of these vessels are presented in Table 2; detailed descriptions are in Appendix A.

Three of the vessels were investigated in some detail: the *FORDS* platform, *T-2* tanker, and the *C1-M-AV1* ship. The characteristic responses of these vessels in various seas, the effects of the vessel motions on the system in question, and similar points were given attention. By way of summary, the following important points can be made.

Availability. There are many ships suitable and available for conversion to heavy-lift operation. In some cases, the conversions are relatively minor. There are very few, if any, available and suitable platforms. A platform fitting the needs of the project would definitely be a custom-built item.

Ease of Construction. There is much more experience in building ships than platforms. The result is that it is easier to design and build an acceptable ship. The limited experience in designing and constructing platforms has made this type of vessel relatively expensive to build.

Table 2. Design Parameters of Various Surface Vessels

Parameter	Vessel				
	T-2 ¹	C-2 ¹	ARD ¹	C1-M-AV1 ¹	FORDS ²
Length (ft)	523	459	489	338	204
Beam (ft)	68	63	81	50	204
Depth (ft)	---	---	---	---	488
Draft (ft)	30	35	15	21	265
Displacement, Full (long tons)	21,900	13,850	14,000	7,500	43,000
Displacement, Light (long tons)	8,500	4,640	10,000	3,200	31,000
Speed, Still Water (knots)	15	15	4	10	No power
Total Cost (\$1,000)	4,670	3,620	3,785	2,820	16,013

¹Design of a Deep Ocean Drilling Ship, NAS-NRC Report No. 984, 1962.

²J. Ray McDermott and Co, Inc., FORDS, Contract No. NBy-37640, April 1964.⁷

Shipyards are not particularly well-suited for constructing platforms. In addition, special facilities are needed for alterations and repairs on platforms, especially if drydocking is required.

Mobility. There is no question that ships are more mobile than any platform yet built. In fact, many platforms have no means of propulsion and must be towed between work sites.

Platforms can be designed to accommodate a propulsion system. A large amount of power is required to move a platform, since the hull configuration is not the best for movement through the water. It can be safely assumed that unless a tremendous (almost unrealistic) amount of power is provided, a platform is considerably slower than a ship.

Accommodations. Small ships are out of the question for the heavy-lift project simply because they do not have enough room for all of the equipment needed for a cable system or pipe string and derrick system. Intermediate size ships may be large enough to accommodate the derrick and pipe string or cable equipment, but there are some limitations on the volume of the load. In general, any vessel discussed in this report is large enough to accommodate the lift equipment of any candidate system.

Platforms are or can be considerably larger than ships. They are clearly superior to ships in that they are not restricted by beam width and deck space. Moreover, it is much easier to build a platform with a large centerwell. For a ship, there is obviously a restriction on how large the well can be; for instance, the *Glomar Challenger* has a beam of 65 feet, yet the well is only 20 feet by 22 feet.

Type of Operation. There appear to be two general types of operations that could be encountered in heavy-lift operations: (1) fast placement or recovery of objects on the ocean floor or (2) a test operation where a subsea system or component is held at depth for testing (similar to the *FORDS* platform⁷). As far as the surface vessel is concerned, these distinctly different operations are not compatible. For the first type of operation, i.e., lowering or recovery, a ship would be satisfactory – assuming the crew were given some leeway in the timing of the operation. For the second type of operation, simply holding a test specimen, there is no choice but to use a platform since the test could take some time and the support craft would have to be capable of withstanding the severest sea states. In this respect the platform is more versatile, since it can perform both types of operations.

Stability. Platforms are inherently more stable under most sea states and would be acceptable in all but the severest conditions; however, it appears possible for all reasonably sized ships to operate as a heavy-lift system at least 95% of the time in all the oceans of the world. As stated before, the importance of stability is related directly to the type of operation. The **FORDS** platform would be an exceptionally stable free-floating vessel, as it must be because of its primary mission of on-station testing. A **T-2** class tanker or equivalent would prove satisfactory in all but hurricane conditions. It appears unnecessary, therefore, to advocate the use of the exceptionally stable surface vessels; they are considerably more than is needed and would prove to be superior to less stable vessels for only a very small portion of the time.

Appendix B presents a comprehensive look into the motions of the **T-2** tanker, the **C1-M-AV1** ship, and the **FORDS** platform, and a less detailed look at the remaining vessels of Table 2. Figure 4 illustrates an important result of Appendix B, namely, the response of these vessels in heave in certain sea states. The heave amplitude at various frequencies is an important input for determining the dynamic stresses in the cable and pipe string systems. It will be seen in the following sections that these vessels offer varying yet acceptable degrees of stability. The **C1-M-AV1**, the smallest of the three, would probably prove to be satisfactory as a surface vessel in all but the more severe environments. There is no question that a ship the size of a **T-2** tanker or a platform similar to **FORDS** would be acceptable as a surface vessel in this project. For the sake of consistency and simplicity, the characteristics of the **T-2** tanker and **FORDS** will be used where pertinent in discussions of the ship and platform systems, respectively.

Conclusions. The general feeling of the authors is that no major distinction needs to be made between ships or platforms. Both would prove satisfactory for the purposes of this project. As discussed earlier and in Appendix B, the choice is really dependent on mission definition and anticipated uses for the heavy-lift system. Each has its advantages and limitations, and the final choice will undoubtedly be based on the total costs of representative vessels. If one were to judge from the composition of the offshore drilling fleet, a ship would probably be the chosen vessel.

Pipe

The possibilities of using pipe as the suspending medium are given a comprehensive examination in Appendix B. Included in the analysis is a look at the equipment associated with pipe handling operations.

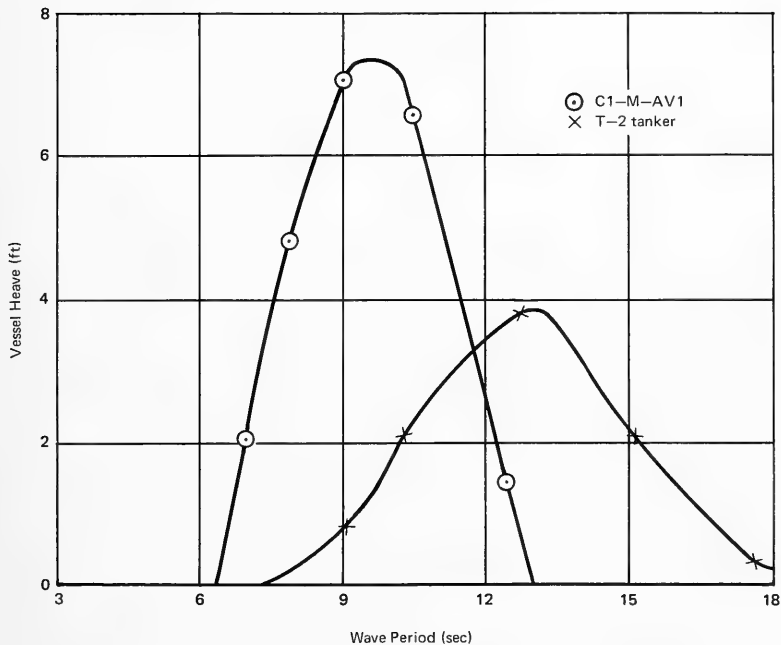

Figure 4. Heave of a T-2 tanker and a C1-M-AV1 in a fully developed sea with 20-knot winds.

Material. Aluminum and steel are the two most common materials used for pipe. It is readily apparent from even the most cursory glance at the literature that aluminum pipe is not suitable for lifting heavy loads. While some aluminum drill pipe has been used in the offshore drilling industry, the loads subjected to the pipe have been comparably mild. In addition, while some grades of aluminum are possibly suitable for heavy-lift applications, it has been found that readily available aluminum pipe is either not made of the stronger grades or is much too small for the loads in question.

High-grade steel is recommended for manufacturing pipe used to support heavy loads. Steels of minimum yield strengths in the range of 110,000 to 150,000 psi are the most suitable for the purposes of this project. Table 3 summarizes the important properties of two steels meeting these requirements.

Table 3. High-Grade Pipe Steels

(Source: FORDS Study, Table XI-8, Volume I)

Steel Grade	Properties	
P-110	Minimum Yield Strength	110,000 psi
	Minimum Tensile Strength	125,000 psi
	Average Elongation in 2 Inches	15%
V-150	Minimum Yield Strength	150,000 psi
	Yield Strength Maximum	171,000 psi
	Average Elongation in 2 Inches	19%

Pipes over 13 inches in diameter have been manufactured using P-110 and V-150 steels (Reference 7, p. S-45). Table 4 presents some relevant design parameters for a suitable range of pipe diameters. These pipes are off-the-shelf items and come in lengths of about 50 feet.

Couplings. Table 5 illustrates how the strengths of typical pipe joints compare with the strength of the pipe. It can be seen that the joints are at least 90% efficient and in two cases are actually stronger than the pipe. The joints are of the "shrink grip" variety, which is very similar to the standard plumbing coupling used in home water systems.

Design. Assuming a safety factor of two for static loading and limiting attention to the severest case of a 600-ton load at 6,000 feet, it can be shown that of the different pipes listed in Table 4, only the last three of V-150 grade steel will meet the requirements. These are 10-3/4-inch OD weighing 71.1, 76.0, and 81.0 pounds per foot, respectively.

It is obvious that at lesser depths and/or with lesser loads the static safety factor would increase.

The combined static force of the pipe string and load is necessary but not sufficient for a realistic design analysis of the pipe system. There are two types of dynamic loading that must be considered in a complete investigation: (1) loads incurred during sudden stops and (2) loads imposed on the pipe due to ship motion.

Table 4. Design Parameters for Steel Pipe

(Source: FORDS Study, Table XI-9, Volume I)

Pipe Grade	OD (in.)	Weight (lb/ft in air)	Allowable Tensile Load ¹ (kips)	Collapse Depth ¹ (ft)
P-110	9-5/8	53.5	85	—
	10-3/4	65.7	1,044	6,680 ²
	10-3/4	71.1	1,134	7,610 ²
	10-3/4	76.0	1,215	8,440 ²
	10-3/4	81.0	1,296	9,280 ²
V-150	9-5/8	53.5	1,166	9,000 ³
	9-5/8	58.4	1,288	10,000 ³
	9-5/8	61.1	1,323	10,950 ³
	10-3/4	65.7	1,424	8,800 ³
	10-3/4	71.1	1,547	9,920 ³
	10-3/4	76.0	1,658	11,000 ³
	10-3/4	81.0	1,767	12,000 ³

¹Safety factor = 2.

²Axial stress = 55,000 psi.

³Axial stress = 75,000 psi.

Based on operational procedures of similar systems, a heavy-lift system employing pipe as the suspending medium would use sections (or "stands") approximately 100 feet long. Thus, after a 100-foot section of pipe is lowered, the entire assembly must be stopped and the next pipe section joined. The pipe-load combination will therefore be stopped and started nearly 60 times during a lowering operation to 6,000 feet. If the system is stopped too rapidly, the resulting change in momentum would subject the support point to extremely high stresses. (An automatic pipe handling system is being developed in which the pipe sections are joined as the load is being lowered. While this system will eliminate much repetitive loading due to stopping and starting, large localized stresses would still be incurred during, say, an emergency stop.)

Calculations based on impulse-momentum and strain-energy considerations were made to determine the stress levels which may be expected during the stop/start lowering procedure. Typical results are shown in Figure 5. As suspected, there is definitely an upper limit on the velocity from which a pipe-load combination can be stopped. The overall impression of the stopping operation is that delicate and careful control will have to be exercised over the entire sequence. While the potential damage of too rapid deceleration is great, the problem is more in the area of a system limitation rather than a serious design drawback. Assuming adequate precautions are taken (which perhaps would be nothing more than having competent operators), it is safe to assume that excessive stresses due to this mode of loading can be avoided during the stopping operation.

The oscillations of the surface vessel, particularly in the heave mode, cause significant stresses in the pipe at the support point. This problem is comparatively difficult to solve because of the nonlinear damping due to drag forces on the oscillating load and added mass. A simplified solution has been derived and a program written for the computer; the output is the normalized amplitude of the maximum dynamic force. Axial forces per foot of heave for various load conditions and wave periods are given in Appendix B.

Table 5. Design Parameters for 10-3/4-Inch OD Casing

(Source: Jones and Laughlin Catalog, Oil Country Pipe, 1968 edition, p.c-25)

Pipe Grade	Weight (lb/ft)	Pipe Tensile Strength (kips)	Joint Strength ¹ (kips)
P-110	55.50	1,754	1,923
	60.70	1,922	2,107
	65.70	2,088	2,289
V-150	65.70 ²	2,847	2,799
	71.10 ²	3,094	2,957

¹ Joints same material as pipe; joints for P-110 pipe could be one grade higher.

² Casing is non-API; available on inquiry basis.

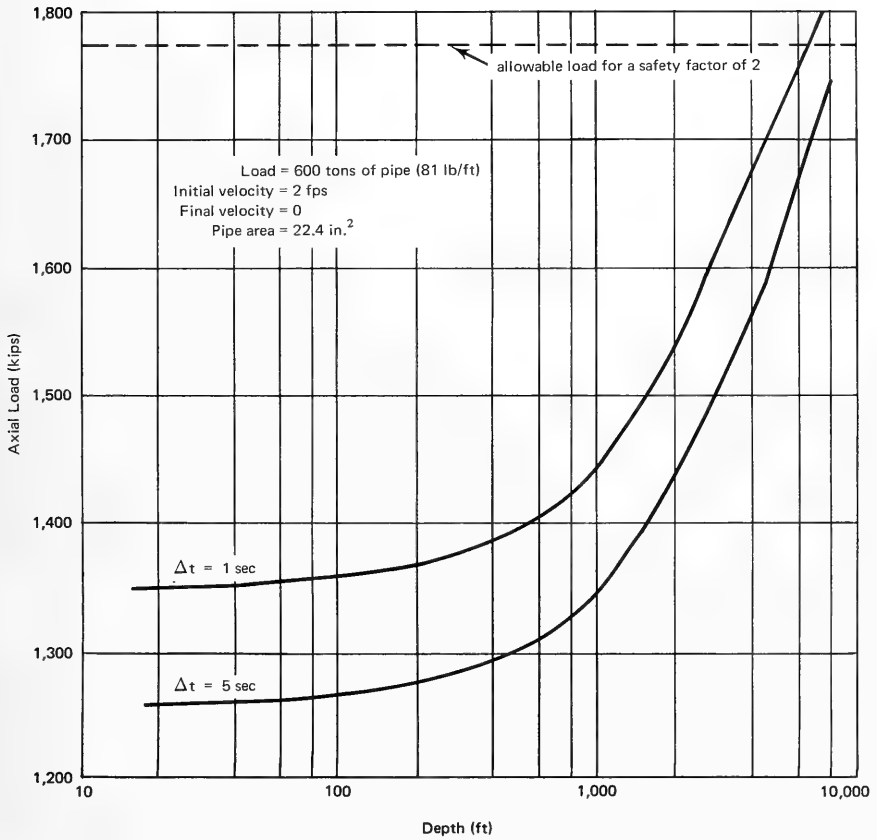

Figure 5. Average total loads due to deceleration of pipe suspension medium.

The heave characteristics of the *T-2* tanker, *C1-M-AV1* ship, and *FORDS* platform were determined by multiplying the response amplitude operators for heave motion in long-crested seas by the Neumann spectrum. Results of this analysis were combined with the force analysis of the pipe string. Typical resulting curves are given in Figure 6.

It can be readily seen that for all realistic conditions (sea state 4 or less) the motions of the surface vessels under consideration will not subject the pipe string to dynamic axial forces greater than 25% of the static 600-ton load. In fact, indications are that the dynamic forces will amount to less than 5% of the static load more than 90% of the time in most of the oceans of the world. This statement acquires added significance when it is realized that no account was taken of the natural tendencies for the system to dampen out motion. Also, there are some devices, such as bumper subs and shock absorbers, which have been designed to eliminate or greatly reduce the effects of vessel motions on suspended pipe strings. The incorporation of these devices into the system would unquestionably make the problem of dynamic loading either insignificant or very easily solved.

Pipe Handling Equipment. The equipment necessary to assemble and lower a pipe string for a heavy-lift operation would be very similar to the standard equipment found at any oil well. A thorough assessment of the required items of equipment and the capacities of these units can be found in Appendix B.

There is substantial evidence to indicate that a considerable portion of the hoisting equipment currently in use is readily adaptable for lifting loads of up to 500 tons in offshore construction. Standard derricks, crown blocks, traveling blocks, tool joints, and draw works will successfully lift a 500-ton load. Limited extensions of current technologies will provide items of equipment which will permit hoisting loads of up to 600 tons, the arbitrary maximum for this project.

Conclusions. It can be stated with confidence that a pipe string of the size discussed previously will satisfactorily support a load of up to 600 tons to a depth of 6,000 feet. It is worth stressing that much of the ocean industry is thinking along these lines. The heavy-lift systems under consideration are actually follow-on versions of systems presently in use. Of course, this is the soundest and most economical method of design; new systems are being evolved from the old, rather than basing new designs on heretofore untried concepts. Mobile offshore drilling rigs are serving as baseline designs for heavy-lift systems of the type under consideration.

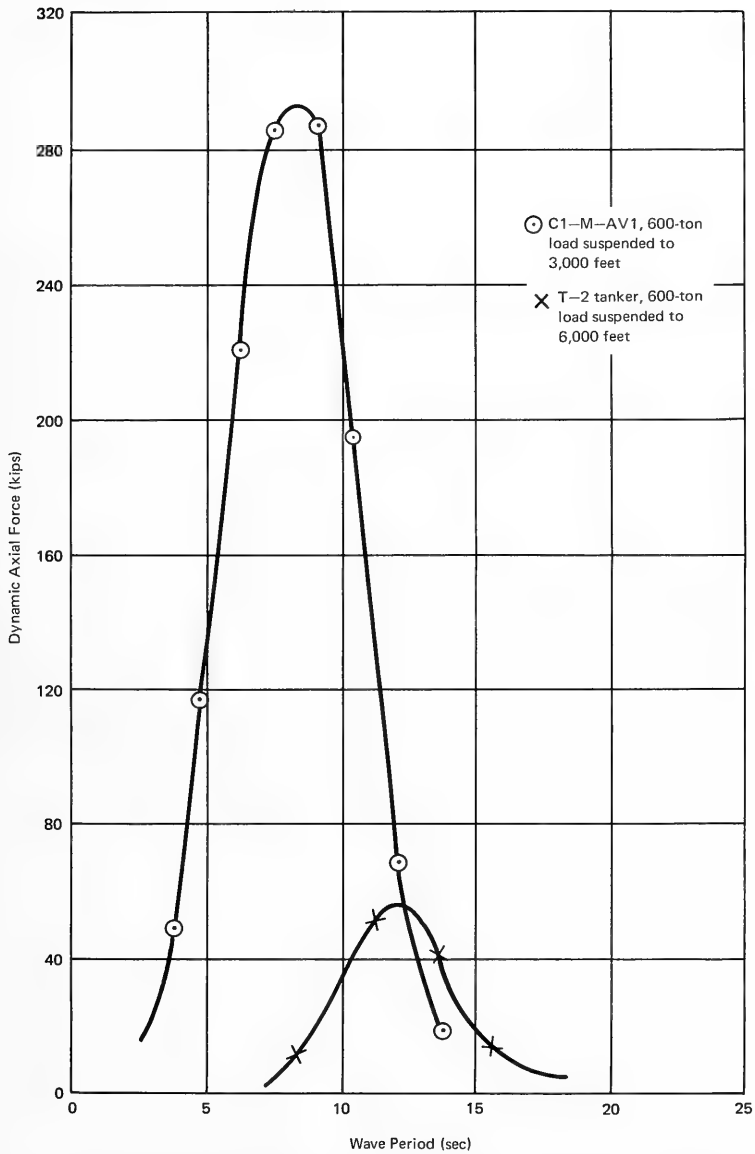

Figure 6. Dynamic axial loads in pipe string for a T-2 tanker and C1-M-AV1 in a fully developed sea with 20-knot winds.

Cable

Candidates employing cable as the suspending medium were examined in much the same manner as pipe systems. In general, the same types of questions were necessarily asked and answered. The state-of-the-art, projected future capabilities, the magnitude and types of loadings, and anticipated problem areas were given most of the emphasis in the study of the "flexible support" concepts.

There are two contenders: wire rope and synthetic rope. Both types have been widely used in ocean-related industries. The desirable and undesirable features of each are well-documented and in many cases are common knowledge.

Synthetic Rope. There are three primary types of materials used for manufacturing synthetic cables: nylon, dacron, and polypropylene. Nylon was the first of the synthetic fiber cables. It has a slight negative buoyancy in water and has a good deal of permanent elongation. Dacron is stronger than nylon but is not generally available in large diameter cables. Polypropylene is slightly less strong than nylon but has the added asset of slightly positive buoyancy; it is available in diameters up to 5 inches with breaking strengths on the order of 600,000 pounds.

Primary advantages of synthetic fiber cables are that they are comparatively buoyant, so no strength is lost due to cable weight, and that they are available in construction which does not twist under load. Disadvantages include a high degree of elasticity, susceptibility to fish bites, and a requirement for large storage areas for large diameter ropes.

Wire Rope. Wire rope is a mainstay of the ocean industries. Its development has closely paralleled the improvements in high-strength steels. It is possible to purchase high-strength rope in lengths up to 5,000 feet, 4 inches in diameter, 6 x 61 classification. This rope is used in dredging operations and has a breaking strength of 713 tons. It is flexible enough to be used as a hoisting rope. The continuous length of a rope that can be manufactured is limited by the weight-handling capacity of the wrapping machines, which is 80 tons.⁸ As a result, the maximum lengths of 4-inch, 3-3/4-inch, and 3-1/2-inch ropes are 5,420 feet, 6,160 feet, and 7,070 feet, respectively. The development of greater capacity rope would require substantial industry wide demand.

For reasons of safety and to account for the susceptibility of cable to dynamic loading, a safety factor of at least five is recommended for most usages. This high factor also takes into consideration the relatively low

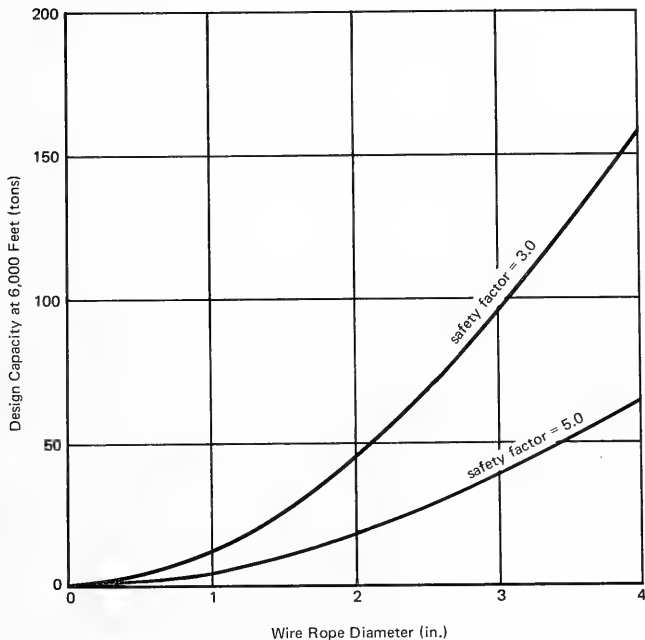

Figure 7. Design load capacity of wire ropes for 6,000 feet water depth.

resistance of cable to fatigue. Preliminary calculations indicate that the load capacity available for design becomes small indeed when a 5:1 safety factor is used. As an illustration, Figure 7 presents the design capacity for 5:1 and 3:1 safety factors; included in these curves are the payload plus an allowance for dynamic loads. From this analysis, a value of 100 tons is selected as the maximum load for a single cable 6,000 feet long and a safety factor of three.

After a detailed investigation of the above and additional factors, it was determined that a 3-1/2-inch diameter cable is the most desirable and feasible wire cable for suspending a load of 100 tons to 6,000 feet. However, there is a compromise: the safety factor is three. Each additional 100 tons, therefore, requires another wire rope plus handling equipment. The 3-1/2-inch wire rope was selected as the most desirable of all wire and synthetic ropes for the purposes of this project.

Design. It is apparent that loads weighing in excess of 100 tons will require more than one cable for support if they are to be safely lowered to 6,000 feet. The need for more than one suspending medium is peculiar to the cable systems. For a 600-ton load, for example, six cables controlled by six coordinated winches will be required for the system. Of primary concern in this or any other multiline system is the problem of cable entanglement. The tendency of wire ropes to rotate under strain and spinning of the load in underwater currents can cause the lines to wrap around each other. Another very serious source of line entanglement is the kinking which results from relieving line tension. There will be a large amount of energy stored in the cables when they are stretched their full lengths under high-load conditions. The release of this energy, initiated by disconnecting the load, will lead to very serious entanglement unless thwarted by some device such as a large strongback. Research on the cable tangling problem is being conducted at the Naval Civil Engineering Laboratory. At present, it should be considered an area of great uncertainty.

A dynamic load analysis analogous to that for the pipe string system was conducted. Heave motion spectra for the *T-2* tanker, *C1-M-AV1* ship, and *FORDS* platform, combined with dynamic load curves for the cable in question, indicate that no serious dynamic forces will be encountered with large vessels in a sea state 4 or less.

It was found that the lighter loads suspended on cable can be displaced considerable distances under heavy currents. However, no unusually high stresses will occur in the cable because of the current loading.

Cable Handling Equipment. The equipment needed to handle the amount and size of cable necessary for this project is within the state-of-the-art. The *FORDS* study⁷ of J. Ray McDermott and Company, Inc., contains a description of some winching equipment capable of raising and lowering a 450-ton payload to 6,000 feet. Each of the four winches supported one-fourth of the load, and was equipped with 6,600 feet of 3-1/8-inch diameter wire rope. As with the pipe handling systems discussed earlier, the winches, sheaves, and other associated items of equipment for the cable systems would be enlarged and strengthened versions of smaller units. The fact they are not off-the-shelf items can be attributed to lack of demand.

Conclusions. The limited load capacity of the largest cable feasible for this project, combined with the necessity of using a multicable approach, has relegated the cable suspension systems to a position inferior to pipe string systems. Probably the greatest drawback is the high degree of uncertainty that must be assigned to cable systems in general. The low fatigue life of cable, the possibility of cable entanglement, and the precise control required during an operation all help make the nature of cable systems unsure.

Buoyancy Systems

The surface-independent systems require that an external source of buoyancy be added to the load. The buoyancy-assist cable systems are also dependent on some source of buoyancy to help reduce the tensions in the cable(s). Hence, an important part of this study was the investigation of sources of buoyancy.

There are two types of buoyancy systems: variable and nonvariable. The buoyancy of the variable systems can be adjusted to a predetermined value and can continually compensate for changes in water density and temperature as the lifting and lowering operations take place. There is no provision for changing the buoyancy of the nonvariable systems once the operation begins. Both types of buoyancy sources are discussed in detail in Reference 9. Also presented in this reference are the results of a thorough analysis of buoyant-assist cable systems.

Nonvariable Buoyancy. There are four possible approaches to supplying a nonvariable buoyancy source to the load:

1. Syntactic foam
2. Hollow buoyancy objects
3. Liquids in containers
4. Metal alloy pressure vessels

For the last two concepts, relatively minor changes in the design would provide a variable buoyancy system.

Syntactic foam is a composite of small hollow spheres (usually glass) in an epoxy resin binder. The formulas for the better syntactic foams are proprietary information. Syntactic foams can return 0.6 pound buoyancy per 1 pound of foam, and can be used in depths up to 20,000 feet with little or no loss of buoyancy. They are, however, expensive; a cost of \$5 to \$6 per pound of foam is not unusual. Disregarding cost, syntactic foam is a most attractive nonvariable buoyancy material.

For hollow buoyancy type of systems, a rather large number of hollow objects are packed into a container. Perhaps the hollow objects could be commercially available glass spheres 10 inches in diameter. The latter are receiving much attention in the industry and are proving to be fairly reliable sources of buoyancy. It is easy to foresee vast and unavoidable handling problems for this type of system due to the inherent brittle property of glass.

Low-density organic liquids in containers have been used as buoyant materials. Gasoline, kerosene, and some other petroleum derivatives have been and are being put into compartmentalized, collapsible bags to provide buoyancy. This system has proven to be awkward, since some objects of rather large volume must be manipulated. In addition, complex rigging gear is necessary to harness the buoyancy.

Spherical or cylindrical metal alloy, external pressure vessels such as submarine hulls are another source of buoyancy. Steel, aluminum, and titanium are the prevalent competing materials for this type of structure. For now and the foreseeable future, high-strength steel represents the best choice as far as cost/effectiveness is concerned. A study of steel pressure vessels is included in Reference 9. In general, steel pressure vessels satisfying the requirements of this project are well within present manufacturing capabilities. They would be resistant to shipboard abuse and, as is true with all buoyancy systems, require much cargo space while in transit.

The consensus of the authors and knowledgeable outside personnel is that the nonvariable buoyancy systems discussed are operationally awkward. During the development of the operational procedures required for these systems (both cable and free ascent/descent), it became apparent that, of all the pertinent functional areas, the problem of what to do with the buoy after the load is released at the bottom was the most damaging factor to the feasibility of the concept. Since the load-buoy combination is nearly neutral, the release of the downward force of the load requires that the upward force of the buoy be opposed by some outside force, perhaps a dummy load. Many schemes were proposed and analyzed in the quest for a satisfactory solution to this problem. It was determined that some form of variable buoyancy system is the only realistic solution.

Variable Buoyancy. Two types of variable buoyancy sources are investigated in this study: (1) gas generators and (2) floodable metal alloy buoys.

Gas Generators. A significant amount of thought and development is being given to systems which expel water from hard-shell containers with a gas. It has been ascertained that air pumped from the surface to displace water is not feasible at depths over 1,000 feet. Thus, most effort has been concentrated in the development of gas generators. The Navy Underwater Weapons Center (NUWC) has successfully conducted feasibility tests using hydrazine fuel with a catalyst which causes spontaneous combustion (see Reference 10, for example). The gas generator, mounted directly on the buoy, provides a controllable decomposition of the gas and, consequently, a controllable buoyancy system.

At present, gas generating units have limited depth and load capabilities. It may be concluded with reasonable confidence that gas generators have not yet reached the stage of development that makes them feasible for heavy lift. Moreover, considering the cost of the hydrazine and the dangers associated with its use, there is some question whether they are even desirable for the heavy-lift project.

Metal Alloy Buoys. The addition of a mechanism for flooding the metal buoys previously discussed is considered the most desirable of the variable buoyancy systems and, therefore, the most desirable of all sources of buoyancy.

Included in Reference 9 is a comprehensive examination of ring-stiffened cylinders made of high-strength steel. The basic configuration investigated consists of a series of cylindrical hulls of uniform size placed end-to-end, the number of hulls depending on the buoyancy required. Each hull can be flooded as necessary to decrease the buoyancy of the entire string to the condition where the remaining unflooded hulls provide just enough buoyancy to lift the entire system upward at an acceptable rate. An important design input for the variable buoyancy system is the conclusion reached earlier that the 3-1/2-inch diameter cable is a near optimum compromise on a strength-diameter basis.

One of the primary advantages of the cylindrical hull, modular-type buoyancy system is that any load can be lifted with only one cable by simply adding buoyancy units to the load. The uncertainties and possibilities of cable entanglement are thereby eliminated. As an example, the 3-1/2-inch, 100-ton capacity cable can be used to lift a 600-ton load by first attaching 500 tons of buoyancy modules to the load. Once the load is placed on the bottom, some of the buoyancy modules can be flooded, so the total downward force on the cable is enough to prevent kinking and still less than 100 tons.

Conclusions. The concept of buoyant assist initially appeared to offer great promise. However, it was found that an important disadvantage of the system is the possibility of extreme dynamic overloads in even comparatively mild seas. Secondly, there is always some uncertainty in remotely activated devices, such as the valves which must open to flood the units. In general, all buoyancy-aided systems must be considered developmental items of uncertain potential, particularly since they are considerably more complex when compared to the other candidate heavy-lift systems.

OPERATIONAL ANALYSIS

After the necessary background data were gathered or derived, the next step was to perform an effectiveness evaluation of the proposed solutions. From this analysis it is possible to specify clear-cut points of departure for refined analyses of the more desirable systems. The following paragraphs provide some discussion of the steps used to evaluate the candidate systems.

Environmental Factors

The natural environmental conditions under which a system is required to operate can vary within fairly wide boundaries. The following factors enter into the environmental analysis of each system:

1. Sea state
2. Currents
3. Wind
4. Air temperature
5. Water temperature
6. Water density
7. Hydrostatic pressure
8. Turbidity
9. Soil properties on the bottom
10. Biological/chemical environment

These factors are evaluated as necessary in the analysis of each system and enter into the discussion only when they may possibly reveal important differences between alternate lift systems; moreover, they are analyzed only in the depth necessary to adequately expose these differences.

Figures of Merit

A figure of merit is an index of quality of a system. It is here that the operating parameters enter into the discussion. As an example, the rate of lifting and lowering a load would form a basis for assigning a figure of merit for the candidates. These factors are discussed only if it is suspected that they will cause significant differences in the final cost/effectiveness evaluation.

The magnitude and importance of the figures of merit in the system evaluations are at best subjective judgments. Arbitrary standards will vary in some logical manner with time, but they will also be assigned varying degrees of importance by different groups or individuals at any given point in time. In addition, technological breakthroughs or similar unforeseeable changes produce new possibilities and invariably alter standards. Thus, it is apparent that the heavy-lift system, the environment, and the ultimate mode of operation are sufficiently complex and variable with time that the possibility of optimization is out of the question. Therefore, the proposed method of effectiveness evaluation is based on the objectives of currency and the possibilities of systematic improvement.

Accountable Factors

Any factors which have or are suspected to have an influence on the figures of merit must be considered. In this study, the most obvious and important factors are the environmental conditions under which the system must operate. Temperature extremes, currents, and ocean waves are examples of the accountable factors which must be inputs for a realistic evaluation.

Other accountable factors given consideration in this report are the critical logistic support considerations. Included here is the ability of the lift system to receive loads from auxiliary support vessels while remaining on station.

In studies for which hard data are available, additional accountable factors include personnel requirements, maintenance policies and requirements, and failure-rate data. These factors can enter the discussions in only a general way, however, since there is very little experience on which to base predictions. For some components there is the possibility of estimating and extrapolating from related experience; for nonelectrical systems, however, this information is hard to locate (if indeed there is any).

Effectiveness Comparisons

A model based on mission-oriented factors is a reasonable method for assessing system effectiveness. This approach is utilized in this study, although some important questions must be answered concerning the possibilities of constructing the more unconventional systems. A modified version of the model proposed by the Weapon System Effectiveness Industry Advisory Committee (WSEIAC) is discussed. The following definitions apply:

System effectiveness is a measure of the degree to which a system may be expected to fulfill a specific set of mission requirements. It is a function of availability, dependability, capability, and the relationships between these factors. **Availability** is a measure of the state of a system at the beginning of a mission. **Dependability** is the probability of a system being in a certain state during a mission, given the state of the system at the beginning of the mission. **Capability** is the ability of the system to fulfill mission objectives, given the system condition during the mission.

The framework for system effectiveness evaluation is based on availability, dependability, and capability. Analytical methods based on the relationships among these factors enabled the authors to arrive at a numerical estimate of system effectiveness.

In general terms, the heavy-lift system must be capable of meeting m operational requirements while operating in n probable states. (The values of the numbers m and n are determined later.) The effectiveness of a system is composed of m figures of merit $e_1, \dots, e_k, \dots,$ and e_m

$$\text{where } e_k = \sum_{i=1}^n \sum_{j=1}^n a_i d_{ij} c_{jk}; \quad k = 1, \dots, m$$

and

e_k is the value of the k^{th} figure of merit

a_i is the probability that the system is in state i

d_{ij} is the probability that the effective state of the system is j , given that the mission was begun in state i

c_{jk} is the value of the k^{th} figure of merit, given that the effective state of the mission is j

The effectiveness vector $\bar{E} = e_k$ can be considered to be composed of three components:

1. The availability vector $\bar{A} = a_i$
2. The dependability matrix $[D] = d_{ij}$
3. The capability matrix $[C] = c_{jk}$

Therefore

$$\bar{E} = e_k = \left(\sum_{i=1}^n \sum_{j=1}^n a_i d_{ij} c_{jk} \right) = \bar{A} [D] [C]$$

Availability Vector

The availability vector is a row vector

$$\bar{A} = [a_1 \dots a_i \dots a_n]$$

The term a_i is the probability the system is in the i^{th} state at the time the mission begins.

Computing the elements of the availability vector requires that the n states be defined. Also, account must be taken of the failure and repair time distributions, checkout procedures, and similar factors to determine the probability that a system is in the i^{th} state. The total number of states which must be explicitly represented in the analysis depends on the system and the degree of importance associated with its availability.

Dependability Matrix

The dependability matrix permits representation of the system during a mission based on its condition at the beginning of the mission. It is a square array of numbers

$$[D] = \begin{bmatrix} d_{11} & \dots & d_{1n} \\ \vdots & & \vdots \\ d_{n1} & \dots & d_{nn} \end{bmatrix}$$

where

$$\sum_{j=1}^n d_{ij} = 1; \quad i = 1, \dots, n$$

and d_{ij} is the probability that the system is in state j , given that the mission was begun in state i .

Formulation of the dependability matrix is dependent upon the effect of failures during a mission and whether repair is possible during the mission. In an ICBM, for instance, no repair is possible during a mission and the state of the system is important only at the end of a mission. For most of the heavy-lift systems discussed earlier, limited repair is possible during a mission yet the fraction of the time out of commission is a mission criterion as is the time at which the failure occurs.

Capability Matrix

The element c_{jk} of the capability matrix is the k^{th} figure of merit associated with the effectiveness of the system in state j .

Given a system in state j , the probability of the system satisfying the k^{th} figure of merit in some predefined manner must be determined. The determination of these elements requires judicious selection of only the critical factors which can perhaps be arrived at only by making realistic assumptions relating to the accountable factors.

The general model discussed above can be applied to the effectiveness evaluation of any system. In highly complex systems, it may be necessary to generate the availability, dependability, and capability matrices with a digital or analog computer. Simulation techniques are also available for use in many system evaluations.

Heavy-Lift Analysis

The value of an analytical approach is that it requires the design team to analyze the impact of and relationships between design parameters. In the case of the heavy-lift system, the prediction of system effectiveness is made difficult by the lack of adequate data. The absence of comprehensive data sources, particularly data of an experimental nature, is currently the weakest step in the entire process. As a consequence, the model just discussed is necessarily subject to simplification and assumption. Nevertheless, the principles and relationships of the model can be used at some future date to analyze new data as it accumulates. At present, there is no choice but that of simplification.

Availability. Two possible system states are assumed in this study:

State 1: operative

State 2: inoperative

Therefore

$$\bar{A} = [a_1 \ a_2]$$

where a_1 = probability the system is operative at the beginning of a mission

a_2 = probability the system is inoperative at the beginning of a mission

$$\sum_{i=1}^2 a_i = 1$$

It is assumed in this study that $a_1 = 1$; that is, that the heavy-lift system is always in its fully usable state at the beginning of a mission. Considering the system will be used for construction, this is a reasonable assumption. As a consequence of this assumption, it can be seen that the heavy-lift system of this study does not possess the operational characteristics of static alert systems; that is, those systems which are kept in readiness for emergency use at some future time in a role of search, defense, or retaliation.

Since the availability vector reduces to $a_1 = 1$, the effectiveness equation reduces to

$$e_k = \sum_{j=1}^2 d_j c_{jk}; \quad k = 1, \dots, m$$

Dependability Matrix. The above assumption on the availability vector (i.e., $a_1 = 1$ and $a_n = 0$ for $n > 1$) reduces the dependability matrix to a $1 \times n$ row vector.

It is recognized in this report that great and unavoidable uncertainties are part of evaluating system dependability. Unfortunately, it is not possible to confront these uncertainties with traditional statistical techniques. For instance, the determination of confidence limits requires the examination of samples drawn from a well-defined population subjected to a well-understood environment. In the case of the heavy-lift system, there is no sizeable sample to examine for calculating the usual measures of reliability.

Since there is no possibility of accurately determining the dependability (failure rates, etc.) of the candidate systems, a less formal technique is necessarily used. Simplification of the problem is possible by assuming there are two states of interest after the system has begun a mission: (1) the fully operable state and (2) the fully inoperative state. These two stochastic system states simplify the effectiveness vector from

$$e_k = \sum_{j=1}^2 d_j c_{jk}; \quad k = 1, \dots, m$$

to
$$e_k = d c_k; \quad k = 1, \dots, m$$

where d is defined as the system dependability.

The uncertainty associated with estimating system dependability, d , can be considerably less than first appears possible. Uncertainty, though significant, is typically confined to a small number of elements. For example, while there is little information on the reliability of multicable systems used for heavy lift, the reliabilities of associated winches, ships, and positioning systems are estimable with a fair degree of certainty. The less certain factors of cable life and the problem of tangling, for instance, can be assigned a range of values. All other assumptions concerning the system remain constant, and the results thereby computed will provide estimates of the sensitivity of the system (financial or otherwise) to changes in the value of the uncertain technical or operational parameter.

In this (conceptual) stage of the project, the system dependability, d , is the equivalent of conventionality. Consequently, the more "dependable" system is the more conventional system. Radical departures from the norm cannot realistically be assigned high levels of dependability because of the inherent lack of favorable evidence. Critical decision-making in design is valid only if the level of confidence is based primarily on the available experimental and operational evidence, with some but less emphasis placed on theory and intuition. When it is stated that in the context of this study that System A is more dependable than System B, the inference is that the available evidence indicates the former has (at least) a smaller number of unsolved problems, i.e., System A is more conventional than System B and, therefore, is a more dependable system. Implicit in this definition of d is the assumption that any candidate is physically and operationally feasible if indefinite amounts of time, money, and effort are allotted to its development. However, the constraints of time and money and a sense of what is reasonable have forced the authors to rely heavily on logical extensions of the state-of-the-art. The narrow time frame for this project, i.e., a 600-ton lift capacity by 1977, leaves no other alternative. Moreover, the priority given the heavy-lift project, or for that matter any other ocean engineering project, does not lead one to assume that more than average development funding will be

available; that is, a crash program substituting resources for time is highly unlikely. As a consequence, the most rational basis for decision-making will include a measure of a candidate's conventionality.

Capability Matrix. Due to the foregoing assumptions and simplifications, the only system state of concern is the operative one, so the capability matrix reduces to a row vector of k elements. Therefore

$$\bar{E} = e_k = d(c_k); \quad k = 1, \dots, m$$

The resulting effectiveness vector will have m terms

$$\bar{E} = d(c_1 \cdot c_2 \cdot \dots \cdot c_m)$$

Each figure of merit, e_k , will have an associated weight w_k , and the dependability will have a weight w_d . The overall effectiveness, E , is defined as

$$E = d^{w_d} \prod_{i=1}^m c_i^{w_i}$$

The product of the figures of merit raised to their respective weighting factor is used to satisfy the requirements of dimensional analysis. A different measure of the overall effectiveness of the systems could be computed using the equation

$$E = d w_d \sum_{i=1}^m w_i c_i$$

when dimensional similitude exists among the effectiveness measures. To avoid this limitation, the more versatile product form of the effectiveness equation is used.

One of the primary goals of system performance methodology is to prevent decisions made on inadequate or inappropriate data. If used properly, the model discussed earlier will prevent such occurrences. As evidenced by the application of the model to the heavy-lift project, there is a chance of the equations being fairly trivial. While it is felt that the present analysis will adequately serve the needs of the project at this point in time, an extended version may possibly be developed at a later date to incorporate the anticipated experimental data. Future work in this area will be particularly helpful in mission definition and detailed design.

Selection of the Figures of Merit

The m figures of merit for each system were determined by assuming that the operational requirements of the 1968 TDP represent the most desirable values for the system parameters; thus, a calculated or estimated value less than the relevant TDP value is tantamount to a decrease in desirability. The following figures of merit and their associated weighting factors were used as guidelines in this study:

<u>Figure of Merit (e_k)</u>	<u>Weight (w_k)</u>
Dependability	3
Mobility	1
Extendability	1
Covertness	1
Rate of lift	2
Oscillation	2
Load transfer at the surface	3
Sensitivity to sea state	2
Sensitivity to water density	2
Sensitivity to water currents	2
Placement potential	2

The following definitions apply:

Dependability. Dependability is a measure of a system's conventionality, i.e., the amount the system exceeds the state-of-the-art. Since this is an indication of the realizability and reliability of a system within the allotted time frame, this figure of merit is assigned a relatively large weight. Dependability is discussed in some detail in the section on the dependability matrix.

Mobility. Mobility is a measure of a system's capability to be moved with relative ease. Self-propelled vessels are considered the most mobile. However, because of increased power requirements, platforms are not considered as mobile as ships. Finally, any system independent of surface support during operation, yet carried on a ship, is considered to have high mobility.

Since the only use of the system will be in underwater construction, it is felt that the high degree of planning in construction projects decreases the need for a rapidly deployable system; thus, rapid transit between construction sites will be unnecessary. Hence, a relatively low weighting factor is assigned to this figure of merit.

Extendability. Extendability is a measure of the possibility of increasing the capacity of a system. For some systems, the probability of increasing the weight, depth, or both is quite high. Also accounted for in this figure of merit is the amount of reworking necessary to extend a system's capacity.

Extendability was given the minimum weight of one. While a consideration for determining how quickly a system could become obsolete, extendability must not be overemphasized if a system is to have well-defined requirements and functional objectives.

Covertness. Covertness refers to a candidate's capability to remain undetected during an operation at sea. The success of presently undefined military operations would perhaps depend on this factor.

Rate of Lift. The rate of lift is self-explanatory. This figure of merit is considered to be important since it indirectly indicates how long the lift system must remain in operation on-station. The longer a system remains on-station, the greater the chance of unfortunate changes in the weather. Thus, it can be seen that the surface supported systems are particularly vulnerable and some emphasis should be placed on how long it takes a system to lift or lower a load.

Oscillation. Oscillation of the load is a measure of the effect of surface vessel motions on the load. For instance, it is possible for the heave of a ship to be magnified at the lower end of a pipe string. Obviously, this action could result in serious damage to the load as it approaches the ocean floor. It is felt that the potential for oscillation and the potential for combating it should be accounted for in this study. A weighting factor of two has been assigned to this figure of merit.

Load Transfer at the Surface. This factor is a measure of the ability of a system to receive loads while remaining on station. This may be one of the most important factors in choosing a system if the predictions of modular construction for underwater installations prove to be accurate. While the latter predictions are yet to be fulfilled, most thinking in the industry is leaning in this direction. Consequently, a heavy-lift system may be useful only if it can receive and transfer modules from other surface vessels while on station. A weighting factor of three reflects the importance associated with this operational characteristic.

Sensitivity to Sea State. The sensitivity of a system to the sea state is given a weighting factor of two. The higher ranking systems in this category can operate in more severe sea states. Those systems highly susceptible to the state of the sea (or severely constrained by it) are given lower rankings.

Sensitivity to Water Density. The sensitivity of a system to water density is concerned with subsurface operations. Systems for which buoyancy is necessary are particularly susceptible to changes in water density. The difficulty of sensing and accounting for these changes is measured in this figure of merit. The weight assigned is two.

Sensitivity to Water Currents. It was found during the course of the study that some systems could very easily be affected by even average currents (particularly with respect to positioning). The difficulty and/or possibility of counteracting these effects are indicated by the value assigned this factor. A weight of two is considered appropriate.

Placement Potential. The positioning of a load is considered to be of some importance. The desirability and feasibility of installing active positioning systems, such as underwater winches, or simply moving the surface vessel for positioning the load are given consideration in this figure of merit. The surface-supported systems were ranked about equally. Some

of the subsurface systems were given smaller scores because of the inherent complications in positioning the loads once they were on the bottom. A weighting factor of two is felt appropriate for this measure of system effectiveness.

The values of the figures of merit and system dependability were subjectively estimated on an arbitrary scale of 1 to 10. The higher the value the better the system meets TDP standards and/or standards set by the design team. A score of 5 indicates that a system does not have any apparent strong or weak points in that particular category. It is important to emphasize that this procedure is a measure of the levels of confidence associated with the selection criteria.

In this study, the rate of increase in favorable evidence with expenditures of time and effort is the equivalent of confidence that a design is physically realizable and operationally acceptable. The more favorable the evidence, the higher the level of confidence that can be assigned to a concept. The purpose of the analysis discussed is to put the levels of confidence into a quasi-quantitative framework and to force the participants of the design team to specify factors which they consider important. This approach or something similar to it is the only way the systems can be compared. While some uncertainty remains for all of the confidence measures, it will remain until the system is built and tested. The numbers, then, are really subjective confidence measures that help establish the relative ranking of the alternative systems based on the evidence accrued on the advantages, benefits, and liabilities of each system's operational and structural qualities.

Costs

The cost analysis of a system is one of the major sources of uncertainty. This is unfortunate since the financial feasibility of a system is ultimately the factor with the greatest control in planning future system configuration. This fact is particularly true in this study because the levels of effectiveness of the candidates are similar in many respects.

Variations in the accuracy of cost estimates can be attributed to differences in cost analyses, errors in the basic data, errors in extrapolation, and similar factors.

While uncertainties about major article costs are by no means trivial, the uncertainties about system specifications and operating assumptions are, at this point in time, deserving of careful scrutiny. Thus, some time and effort were allotted during the course of this study to assure that all possible, yet realistic, variations of a candidate system's functional

specifications and characteristics were considered. As described, the resulting systems are more schematic than actual. While errors of omission are unavoidable, it should be understood that the performance characteristics imposed on the designers are fairly gross and that detailed design is out of the question. It is suspected that during the development program additional requirements will be imposed on the project which will be minor, but still contribute to increasing costs. As the length of the development program increases and related development is carried on in other fields, minor improvements become more opportune. As a consequence, and other things being equal, it appears that the cost estimates are relatively accurate where the magnitude of the required technological advance is small. Where the magnitude of the technological advance still to be achieved is great, a considerable amount of potential variability should be associated with the cost estimate. Of the high-development, little-background type of projects, the experience of industry has been to grossly understate the magnitude of anticipated costs.

The cost estimates used in this study are: (1) the initial procurement-construction cost and (2) the estimated daily operating costs. It is assumed that the respective lifetimes of the systems are roughly the same. The construction-procurement cost is, of course, of interest in any study; the recurring operating cost is included to provide a crude but revealing measurement of the size of the operating budget which might be necessary during a system's lifetime.

Systems Descriptions

A system representative of each major category is used in the effectiveness analysis. These systems possess what appear to be the best combinations of the critical design characteristics. They are specified in enough detail to permit valid and important distinctions to be made between the competing concepts. Table 6 presents the systems capable of 100-ton lifts. Systems with a 600-ton capacity are presented in Table 7.

Results and Conclusions

Table 8 summarizes the results of the effectiveness evaluation. The average score for each system for each figure of merit is given. Table 9 presents the composite scores of each system. It should be noted that two systems with scores of the same order of magnitude are considered to be essentially equal in overall effectiveness; only very wide differences among the scores are significant.

Table 6. Candidate Systems – 100-Ton Lift

Item	Hydrodynamic Winch	Platform and Pipe	Ship and Pipe	Platform and Cable	Ship and Cable	Free Ascent/Descent	Winch-Down	Ship With Buoyant Assist	Platform and Buoyant Assist
Surface vessel Length (ft)	142.4	195	450	195	300	450	450	450	195
Beam (ft)	28.8	195	75	195	50	75	75	75	195
Draft (ft)	17.9	45	30	45	20	30	30	30	45
Displacement (short tons)	1,259	8,900	15,000	8,900	3,000	15,000	15,000	15,000	8,900
Centerwell (ft)	---	170 x 170	30 x 30	170 x 170	20 x 20	30 x 30	30 x 30	30 x 30	170 x 170
Speed (knots)	10	10	15	10	15	15	15	15	10
Design features	a. One 3-in. OD lifting line b. Safety factor = 1.95 in a sea state 3	a. Twin-hull platform with 160 ft derrick b. Pipe is 10-3/4 in. OD, P-110 grade, 53 lb/ft; joints of V-150 material, shrink-grip variety	a. Converted T-2 tanker equipped with derrick and centerwell b. Pipe is 10-3/4 in. OD, P-110 grade, 53 lb/ft; joints of V-150 material	a. Twin-hull platform b. Wire rope, 3-1/2 in. OD c. Traction hoists with 14 ft drum	a. 7,200 feet of 3-1/2 in. OD hoist with 14 ft drum b. Traction hoist with 14 ft drum c. Converted C1-M-AV1 with centerwell	a. Converted T-2 tanker b. Rate of lift = 2 fps c. Five 20-ton buoys reqd d. One 3-1/2 in. OD cable	a. Converted T-2 tanker b. Winch reqd at a cost of \$150,000 c. Five 20-ton buoys reqd	a. Converted T-2 tanker b. Traction hoist with 14 ft drum c. Cable stowage drum 18 ft dia	a. Twin-hull platform b. Generally the same as ship with buoyant assist
Costs (\$1,000)	83	1,449	1,449	2,900	528	678	828	527	527
Lifting equipment									
Vessel construction or modification	1,360	10,000	4,000	10,000	1,500	5,500	5,500	4,000	10,000
Outfitting	---	5,500	1,500	5,500	1,500	3,000	3,000	1,500	5,000
Daily operating	10	10	10	10	10	5	5	7.5	7.5

Table 7. Candidate Systems — 600-Ton Lift

Item	Hydrodynamic Winch	Platform and Pipe	Ship and Pipe	Platform and Cable	Ship and Cable	Free Ascent/Descent	Winch-Down	Ship With Buoyant Assist	Platform and Buoyant Assist
Surface vessel Length (ft)	250	195	450	195	450	195	195	450	195
Beam (ft)	62	195	75	195	75	195	195	75	195
Draft (ft)	30	45	30	45	30	45	45	30	45
Displacement (tons)	7,440	8,900	15,000	8,900	15,000	8,900	8,900	15,000	8,900
Centerwell (ft)	--	170 x 170	30 x 30	170 x 170	30 x 30	170 x 170	170 x 170	30 x 30	170 x 170
Speed (knots)	10	10	15	10	15	2 to 3	2 to 3	15	2 to 3
Design features	a. Four 3-1/2 in. OD cables b. Safety factor ≈ 2.46 , assuming a dynamic load 10% of static c. Lifting rate of 2 fpm	a. Twin-hull platform with 160 ft derrick b. Pipe is 10-3/4 in. OD, V-150 grade, 81 lb/ft c. Shrink-grip pipe joints of V-150 material	a. Converted T-2 tanker equipped with derrick and centerwell b. Pipe is 10-3/4 in. OD, V-150 grade, 81 lb/ft c. Shrink-grip pipe joints of V-150 material	a. Twin-hull platform with six 100-ton winches b. Six cables, each 7,200 ft long c. Traction hoist and cable storage drums	a. Converted T-2 tanker with six 100-ton winches b. Six cables, each 7,200 ft long c. Associated traction hoists and storage drums	a. Twin-hull platform b. Six 100-ton buoys read, each buoy 44 ft long and 15.6 ft dia c. Winch read at a cost of \$150,000	a. Twin-hull platform for ease of handling b. Six 100-ton buoys, each 44 ft long, and 15.6 ft dia c. Winch read at a cost of \$150,000	a. Converted T-2 tanker or equivalent with centerwell b. Six 100-ton buoys each 44 ft long, and 15.6 ft dia	a. Twin-hull platform with adequate storage area b. Six 100-ton buoys each 44 ft long, and 15.6 ft dia
Costs (\$1,000)	399	1,449	1,449	3,170	3,170	4,068	4,218	4,595	4,595
Lifting equipment		1,449	1,449	3,170	3,170	4,068	4,218	4,595	4,595
Vessel construction or modification	8,100	10,000	4,000	10,000	4,000	10,000	10,000	4,000	10,000
Outfitting	--	5,500	1,500	5,500	1,500	3,000	3,000	1,500	5,500
Daily operating	20	20	20	20	20	15	15	15	15

Table 8. Figure of Merit for Candidate Load Handling Systems

Criteria	Weight	Hydro-dynamic Winch		Platform and Pipe		Ship and Pipe		Platform and Cable		Ship and Cable		Free Ascent/Descent		Winch-Down		Ship With Buoyant Assist		Platform With Buoyant Assist		
		100 tn	600 tn	100 tn	600 tn	100 tn	600 tn	100 tn	600 tn	100 tn	600 tn	100 tn	600 tn	100 tn	600 tn	100 tn	600 tn	100 tn	600 tn	
Mobility	1	7	7	5	5	10	10	5	5	10	10	10	10	10	10	10	10	10	5	5
Extendability	1	6	5	10	8	10	8	6	7	6	6	4	4	4	4	4	7	7	7	7
Covertness	1	3	3	3	3	5	5	4	4	4	7	6	7	6	7	6	6	6	4	4
Rate of lift	2	3	3	9	8	9	8	8	8	8	8	7	7	8	8	8	8	8	8	8
Oscillation	2	4	5	9	9	9	9	9	9	9	7	9	9	9	9	9	6	6	9	9
Load transfer	3	6	5	9	8	7	5	10	8	7	5	6	4	6	4	7	4	8	7	7
Sensitivity to sea state	2	5	6	9	9	8	8	9	9	7	7	9	9	9	9	6	6	6	7	8
Sensitivity to water density	2	10	10	10	10	10	10	10	10	10	10	5	5	6	6	8	8	8	8	8
Sensitivity to water currents	2	9	9	9	9	10	10	9	9	9	9	4	4	5	5	7	7	7	7	7
Placement potential	2	7	7	7	7	8	8	8	8	8	8	5	5	6	6	7	7	7	7	7
Dependability	3	8	6	8	8	10	8	8	8	6	8	4	2	4	2	6	4	6	4	4

Table 9. Effectiveness of Candidate Systems

System	$E \times 10^{-16}$ (100 tn)	$E \times 10^{-16}$ (600 tn)
Hydrodynamic Winch	1.99	0.90
Platform/Pipe	1,180.00	524.00
Ship/Pipe	3,720.00	543.00
Platform/Cable	1,560.00	288.00
Ship/Cable	587.00	77.30
Free Ascent/Descent	1.24	0.17
Winch-Down	5.25	0.17
Ship/Cable/ Buoyant Assist	39.50	2.19
Platform/Cable/ Buoyant Assist	60.30	15.60

Exercise of the model served as confirmation of the authors' findings. Based on the assumptions of the model and the results of the investigations and calculations, it can be confidently asserted that a surface vessel lowering and raising a load via pipe string is the most realizable approach for compliance with the requirements of the project. There is little if any question that this approach offers the greatest possibility of success, yet still has high degrees of safety and predictability. While there are some shortcomings to a pipe string system, they are not in the realm of the unknown; no research and development is required before it can be built, nor is there a need to resort to untried techniques and equipment. The pipe string system is essentially state-of-the-art in both size and methodology.

For 100-ton loads there is the possibility of using cable as the suspending medium. As discussed earlier, suspending 100-ton loads from a 3½-inch diameter cable is feasible although the safety factor used would probably not meet with industrywide acceptance.

POSITIONING AND GUIDANCE OF LOADS

Accurate placement of ocean bottom resting loads has not necessarily been a serious requirement in the past. Emplacement of NCEL's Submersible Test Units, for example, requires only that the bottom site is reasonably flat, that the bottom sediments have sufficient strength to support the weight of the test rack, and that the coordinates of the surface ships, during emplacement, be known within the degree of accuracy provided by LORAC. Future sea floor installations, however, may require very precise alignment of two or more construction modules. The positioning of the first module in the complex may not be as critical as the positioning for those which follow. The first unit will be positioned at a site which is reasonably flat, where turbidity is at a minimum, and where the soil has the desirable strength properties. Subsequent units must mate with those emplaced with a fairly high degree of precision.

Concepts proposed as feasible for positioning and guidance systems include:

1. Manned and unmanned submersibles capable of grasping suspended leads and translating and/or rotating them for accurate alignment.
2. Multiple underwater winches, mounted either on the load or anchored to the sea floor, which would be used to position modules over preselected sites.
3. Bottom crawling vehicles which would depend upon tractive force for displacing loads.
4. Dynamic ship positioning systems sensitive enough to provide accurate displacement of loads suspended 6,000 feet below.
5. Guidelines and templates similar to those used in the offshore oil industry.

It is too early in the technology of underwater construction to state with certitude the necessary alignment tolerances. The Deep Ocean Technology (DOT) program TDP can serve as a point of departure. As previously stated, this document specified the following alignment tolerances for 10- to 30-ton loads to be handled by the near bottom transport subsystem (no tolerances were specified for positioning loads handled by the lifting/lowering subsystem):

Alignment tolerance (translation)	$\pm 0.1\text{--}0.5$ ft
Alignment tolerance (rotation)	$\pm 1\text{--}3$ deg
Attitude tolerance (vertical)	$\pm 1\text{--}3$ deg

To the above could be added the following desirable system characteristics:

1. Compatibility with interfacing subsystems, i.e., lifting/lowering and near bottom transport.
2. Reliability and safety.
3. Greatest possible operating radius.
4. Lowest possible cost consistent with meeting all of the aforementioned criteria.

***DIVERCON I* – A TEST CASE**

Before opening arguments for feasible deep ocean load positioning and guidance systems, a shallow water, diver-assisted construction project – *DIVERCON I* – will be described.¹¹ *DIVERCON I*, a diver construction experiment developed for *SeaLab III*, serves as a microcosm for future operations involving the positioning and assembly of very large construction elements. The basic *DIVERCON* structure consists of a cylinder, open-ended at the bottom and capped with a dome and is assembled from three mild-steel, ring-shaped modules. The structure may be blown dry with air or a helium/oxygen gas mixture and used as a dry storage or diver repair facility.

Hallanger reports that the three major technical problems encountered during the development of *DIVERCON* were:

1. Devising a means for lifting and moving the modular elements into a precisely determined location on the sea floor.
2. Mating the modular units and obtaining an effective seal between sections.

3. Corrosion of the component materials.

At first, *DIVERCON* engineers used a lift device consisting of an open-ended buoyancy chamber equipped with a lifting hook. The diver operator could add gas to the chamber for increased lift and could decrease lift by bleeding gas through a vent valve. The buoyancy chamber, however, proved to be unstable. In lift tests, divers discovered that they would either add or remove too much air, resulting in the buoy/load assembly accelerating upward or falling to the sea floor. The adjustment for the desired state of neutral buoyancy was not readily achieved. The developers next tried a "tethered lift" system using the same sky hook principle, but with the buoyancy chamber at all times tethered to the bottom with a two-point moor (Figure 8). One mooring point was a portable anchor equipped with five cylindrical variable ballast tanks which could be blown dry to reduce the submerged weight of the anchor and which, when flooded, would provide 2,000 pounds of deadweight. The other moor was provided by the steel/concrete anchor clump of the *DIVERCON* habitat.

A hydraulic winch mounted in the bottom of the lifting chamber served two functions: (1) lifting and lowering of the prefabricated habitat ring modules and (2) displacement of the chamber along the trolley line connecting the two mooring points. The winch runs on hydraulic power supplied from the control console by a hydraulic pump and electric motor. In shallow water test, the tethered lift system proved to be a workable scheme for providing both lateral and vertical displacement of the ring modules.

The sequence of events for mating the ring modules consist, first, of coarse rotational alignment using the painted pattern on the module extension as a guide. A series of fluted rods projecting from the lower module then engage the edge of the upper module. Thus, translational guidance is assured between modules. Two V-blocks insure that the appropriate guide rods are engaged and also provide the final rotational alignment. It is estimated that divers utilizing this system were able to align 10-foot diameter modules to within a tolerance of $\pm 1/8$ inch.

After a thorough survey of commercially available latch and fastening devices, a drawhook container latch was selected since it best met the required criteria: strength, durability, ability to provide sufficient force to effect a seal between modules, and easy operability by free-swimming divers. The first choice from among several candidate sealants was an elastomeric sealing tape of 1/4-inch thickness used in conjunction with a silicone grease lubricant.

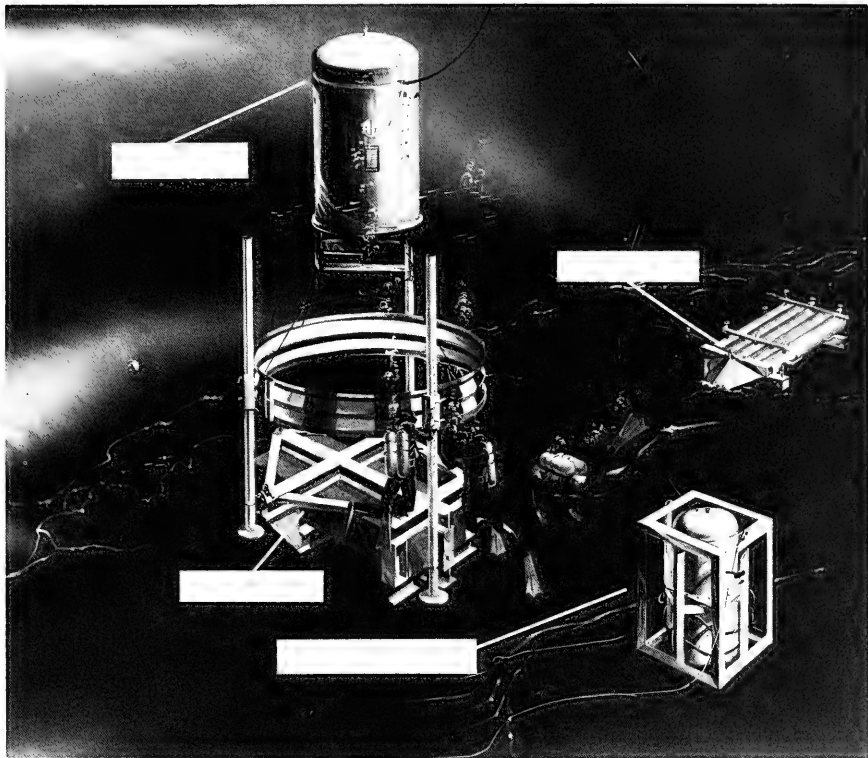

Figure 8. *DIVERCON I*.

The *DIVERCON I* project, a concept already tested and proven during shallow water tests in 50 feet of water, will be attempted again during *Sealab III* at a depth of 600 feet.

In future construction projects, whether diver assisted or at depths beyond present diving limits, some of the problems and solutions encountered in *DIVERCON I* will develop. Construction modules may be lowered to the approximate bottom site and coarse alignment will be provided by the surface vessel, underwater winches, guidelines, or by manned or unmanned submersibles. Guide rods, keyways, or electronic devices will then provide the fine alignment necessary to construct large, integrated sea floor installations.

MOTIVE SYSTEMS

Most concepts for positioning and guidance require both motive and alignment systems. In the discussion that follows, a distinction is drawn between the mechanical devices responsible for final emplacement of bottom loads and the subsystems, whether acoustic or photo-optical, which provide necessary feedback to guide emplacement. Some of the candidate motive systems are limited most by the availability of power at 6,000 feet. First to be discussed, then, are the motive systems for positioning suspended loads.

Winches

J-Star. A system utilizing the winch-anchor approach, for use in underwater search and recovery, has been successfully developed and employed by Jacobson Brothers, Inc., of Seattle, Washington.¹² Called the J-Star, the system uses four anchors and a remotely controlled camera-manipulator array. The system is illustrated in Figure 9.

The method of operation is relatively rapid and simple. The recovery vessel is first anchored in a three-point moor or a single-point moor using bow thrusters for positioning. Four camera anchors are then installed and the camera-manipulator is deployed. The array is supported by a single cable from the surface. Lateral movement of the array is achieved by paying out or winding (under tension) the four lines to each camera anchor by means of a four-spool hydraulic winch mounted on the recovery vessel. It is claimed that precise positioning within a fraction of an inch, uninfluenced by tides, is possible. The system is used, primarily, in water more than 600 feet deep, and long duration explorations in depths of around 3,500 feet are possible. The unit is extremely steady and has been used to locate, grasp, and raise a large number of torpedoes, arrays, and aircraft.

It is conceivable that this system could be modified to the point where it could be utilized for the placing of heavy modular units. However, the inherent need for cables, particularly for support of the array, would probably place a limit on the weight of the unit suspended. Nevertheless, it does appear that given moderate weight and depth requirements, only minor design problems must be solved to utilize this successful system for extremely accurate positioning of underwater loads.

Submersible Winches. Submersible winches have been used to depths greater than 1,000 feet, mostly in a vertical attitude to move loads up or down. *SeaLab III* will use a winch to ferry the personnel transfer capsule (PTC) from the surface to the habitat at a depth of 600 feet. The winch was

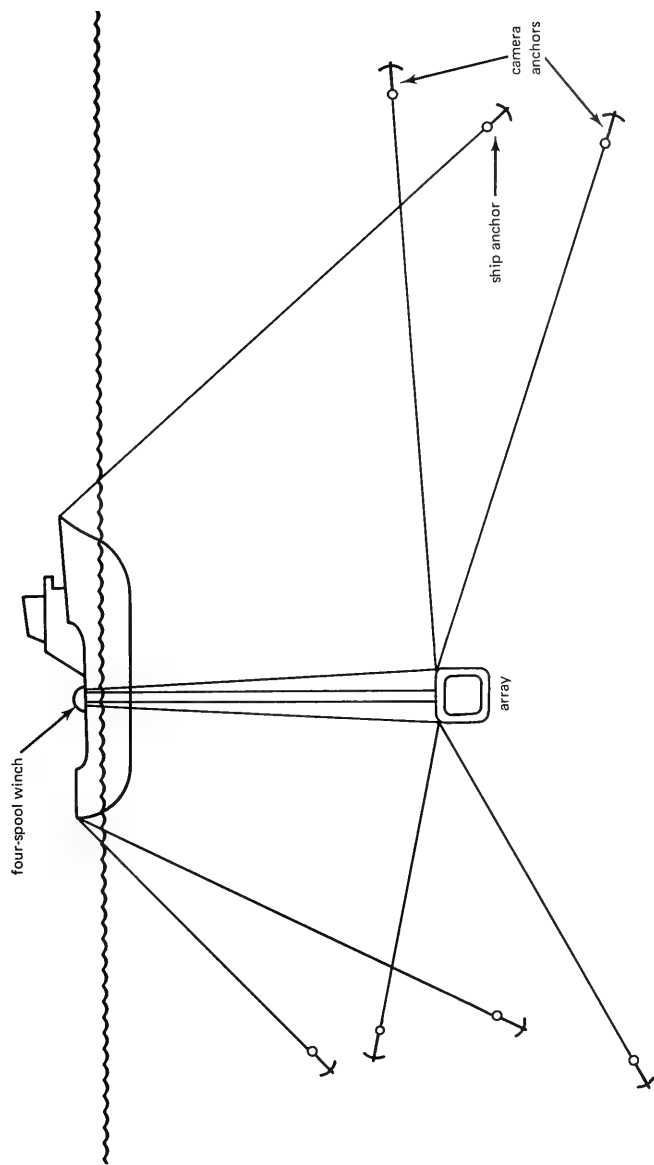

Figure 9. J-Star search and recovery system (based on a figure in Reference 12).

designed for a line tension of 5,000 pounds. According to cognizant personnel, the availability of power is the primary limitation on submersible winches at depths as great as 6,000 feet. A bottom-supported winch with a 10,000-pound rated capacity will move a suspended load about 50 feet and about 230 feet for 100-ton and 600-ton loads, respectively, at a depth of 6,000 feet. Submersible winches operable at 6,000 feet are not available as off-the-shelf items, so estimated costs run high. Previous estimates indicate that the cost for a 10,000-pound winch to operate at 6,000 feet may exceed \$250,000.^{3,13}

The use of underwater winches in the deep ocean requires anchorages to act as reaction points. Some types of anchors suitable for this function include explosive anchors, deadweight anchors, pile anchors, and embedment anchors. The most likely candidates are probably explosive and embedment anchors.

Underwater winches are likely to require the use of a submersible with controlled appendages to operate the winches. Activation of the winches may be accomplished remotely if sufficient reliability can be built into these systems. Several configurations for the use of underwater winches were suggested by Kusano in an unpublished report.¹⁴ Schematic diagrams of the use of a bottom winch and an auxiliary manned submersible are shown in Figures 10 and 11. Figures 12 and 13 show concepts in which the winch is mounted on the load. Figure 14 illustrates the use of a winch with a manned bottom crawler vehicle.

Bottom Crawler

By employing the tractive force developed by wheels or tracks, a bottom crawler could conceivably displace and position heavy, suspended loads. The vehicle, manned or unmanned, would grasp the load and direct final lowering and positioning. The vehicle would be powerful enough to pull or push the suspended load to the desired alignment position or it could serve as a work monitor, relaying positioning data to the surface based lifting/lowering system.

As a guidance and positioning subsystem, however, the bottom crawler concept has some serious limitations. First, is its dependence on bottom soil properties. Except where sandy, rocky, or firm soil abound, these vehicles will be prone to sinking-in and becoming hopelessly mired in bottom sediments. Where soils have sufficient strength to allow operation of crawlers, stirred-up bottom sediments are likely to obscure visibility.

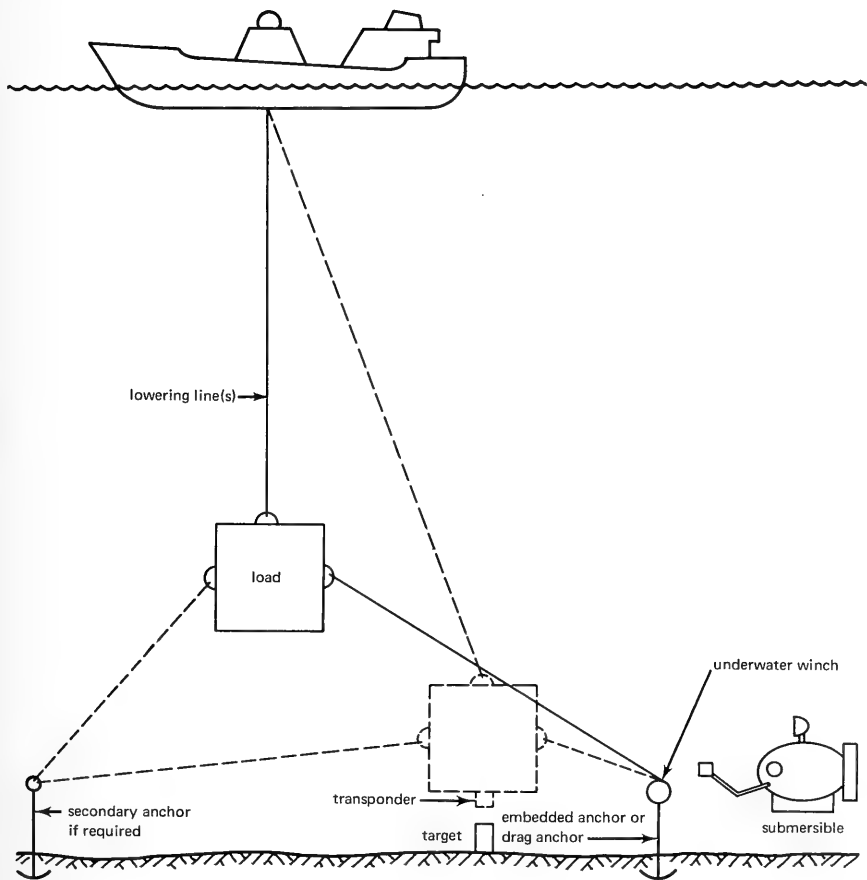

Figure 10. Lateral movement of loads with an underwater winch and anchor system.

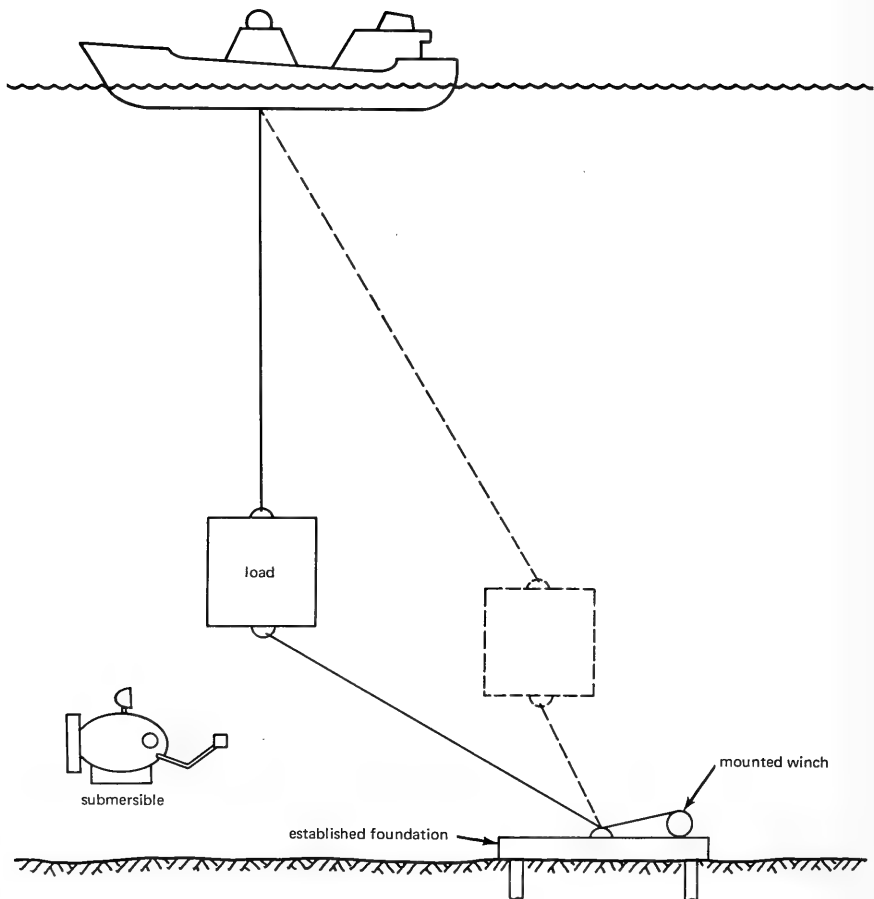

Figure 11. Load movement to an established foundation.

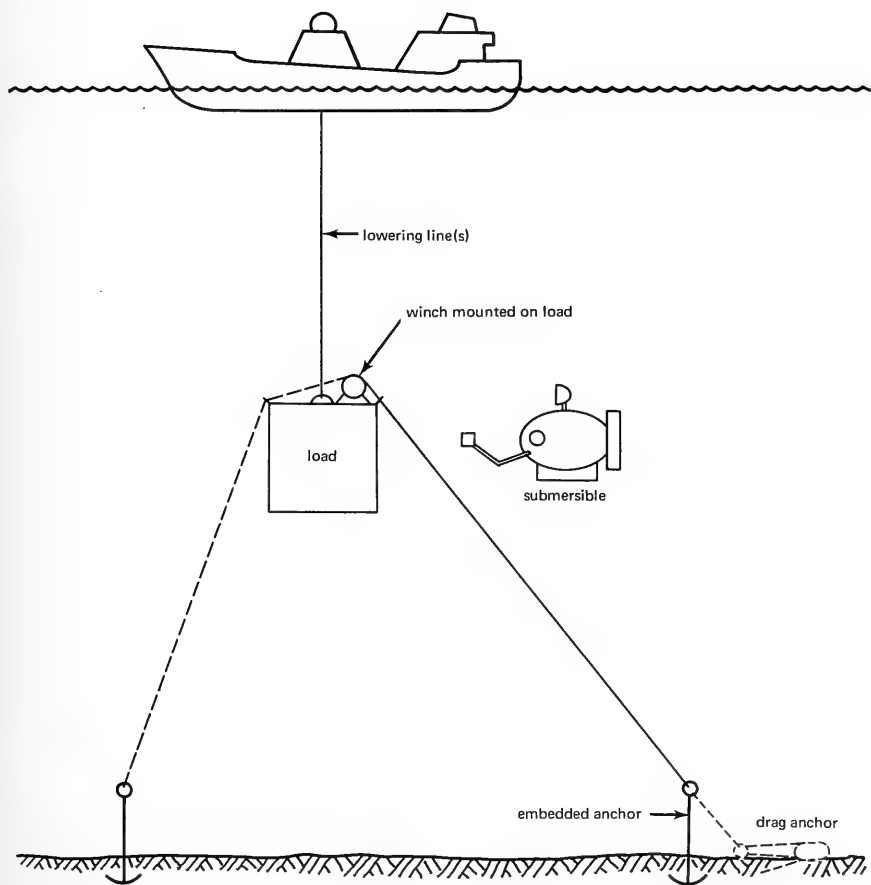

Figure 12. Underwater winch mounted on load.

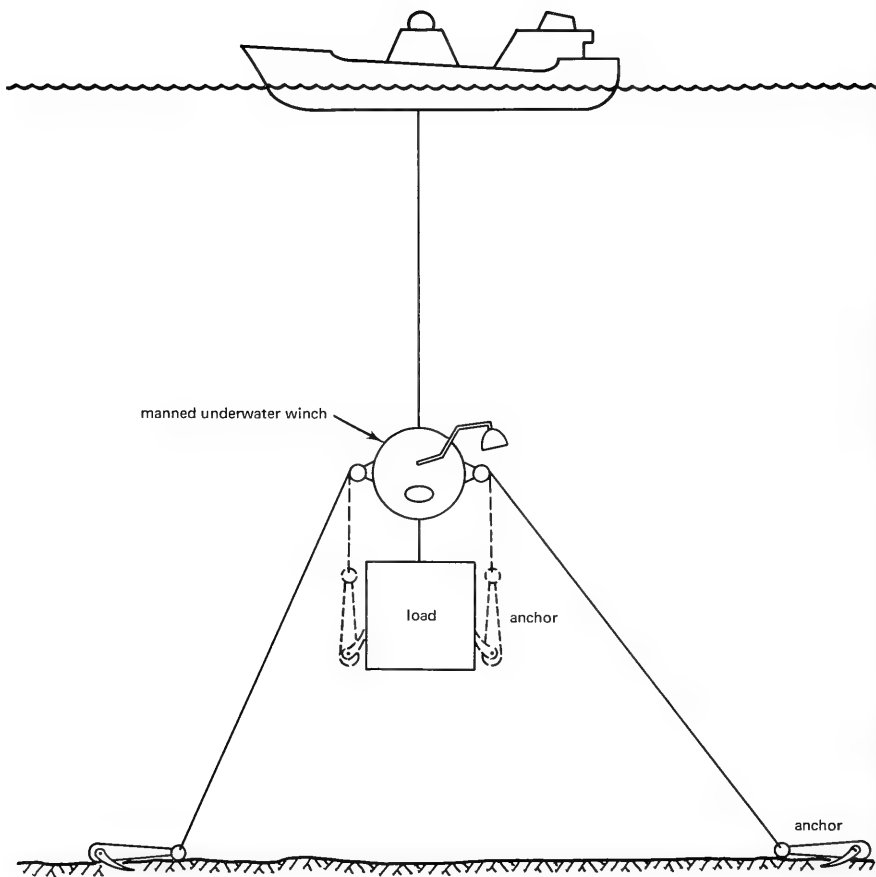

Figure 13. Manned underwater winch.

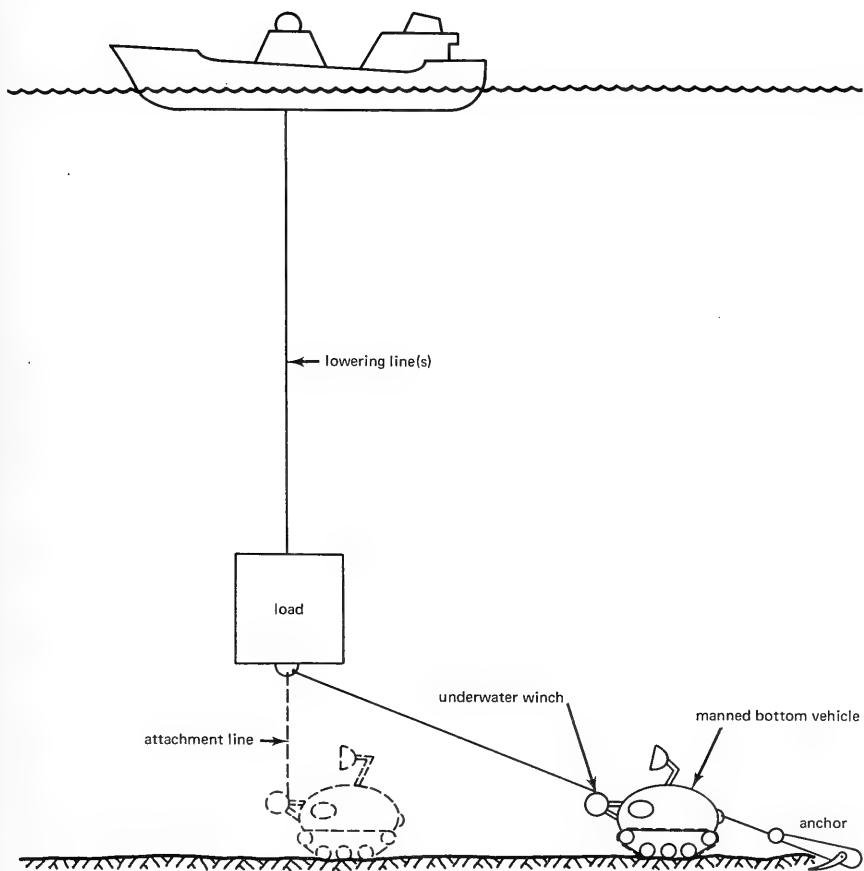

Figure 14. Manned bottom vehicle with winch.

A bottom crawling vehicle with integral power supply will have serious limitations on its ability to perform heavy and/or prolonged tasks. Integral power will be provided by storage cells, lead/acid or silver/zinc, and the maximum amount of storable energy available will be several hundreds of kilowatt hours. Crawlers dependent on external power sources, either surface based or bottom based, lack the mobility of self-contained vehicles. Higher density integral power sources such as fuel cells and nuclear generators with power output in the range required are currently beyond the state-of-the-art.

The attachment of telechiric devices or other vehicle appendages to heavy pendulous loads could prove disastrous from another standpoint. The relatively low mass and tractive force of the crawler in comparison with the mass of the suspended load means that the crawler would be subject to unplanned displacements of the load caused by movement of the surface support system. This could be an especially unfortunate situation if the load were to begin to swing toward the crawler prior to attachment of the vehicle appendages.

Although not considered in the current study, the development of bottom crawling vehicles with clearly defined missions in ocean floor exploration, bottom mapping, and soil property testing may prove to be feasible and useful deep ocean construction work systems. If so, a secondary mission for this vehicle could be that of load guidance and placement monitor. Observers aboard the crawler could relay alignment and position corrections to the surface load support system. However, a bottom crawling vehicle, the prime mission of which is to actively guide and position heavy, suspended loads, is not considered to be a desirable or even feasible concept.

Submersibles

Currently operational deep diving submersibles, as well as those planned for completion in the near future, are discussed elsewhere.^{15, 16} Two guidance and positioning roles were initially considered for submersibles: (1) physical displacement of suspended loads using the thrust of the vehicle propulsion system and (2) relaying of load position corrections to the load surface support system (ship or platform).

The first role disregards the thrust capabilities of all existing and projected, battery powered submersibles. Available thrust levels rarely exceed 200 pounds, which is all that is required to propel small underwater vehicles at speeds of 1 to 2 knots. A 200-pound horizontal force (typical of the thrust available on a conventional submersible) will displace a 100-ton suspended load about 4.5 feet from the vertical and a 600-ton load less than 1 foot. Significant displacement, say 100 feet, requires about

4,500 pounds and 20,000 pounds, respectively, for 100-ton and 600-ton loads. Unlike bottom crawling vehicles, submersibles will stir-up bottom sediments only slightly. They are also far less susceptible than bottom crawlers to becoming stuck in areas where soft, pelagic sediments predominate.

The second role, that of observer and relayer of position corrections to a surface based positioning system, i.e., dynamically positioned ship or platform, is probably a more feasible role for a deep diving submersible. An acoustic load targeting system patterned after the one developed by AC Electronics Corporation for drill hole reentry could serve as the prime load positioning subsystem with a submersible (which could be any one of several boats currently available with depth limits in excess of 6,000 feet) serving as a backup in the event of failure of the prime acoustic targeting system.

Displacement/Rotation of Surface Craft

The first step in lifting or lowering a load will be to determine the location of the surface vessel on the ocean. This obvious prerequisite for a successful operation implies that the vessel will be equipped with some advanced positioning and navigational systems which could be used to position the load on the bottom.

It is predicted with some confidence that dynamic positioning will be the most suitable system for maintaining surface position. The primary data needed in a dynamic positioning system are the relative positions of the surface craft and various points on the ocean floor. The more advanced systems are able to maintain a vessel's position over one point within fairly restrictive tolerances. In the case of the heavy-lift system, the relative positions of the load and ship, in addition to the relative positions of the load and a reference point on the bottom, would be required data inputs. An automated positioning system could provide commands to the positioning propellers to maneuver the ship into a position where the load could be placed on the desired spot. This system would work for both cable and pipe string suspension systems and would require only a slight modification to the command systems presently used for dynamic positioning. Figure 15 illustrates the arrangement of the components. A reference sonar beacon would have to be placed on the load, but this would probably be standard equipment for most ocean bottom installations. Assuming steady state conditions, a load could probably be placed within a circle of radius 1 to 2% of the water depth. For most near-term underwater installations this tolerance may be acceptable.

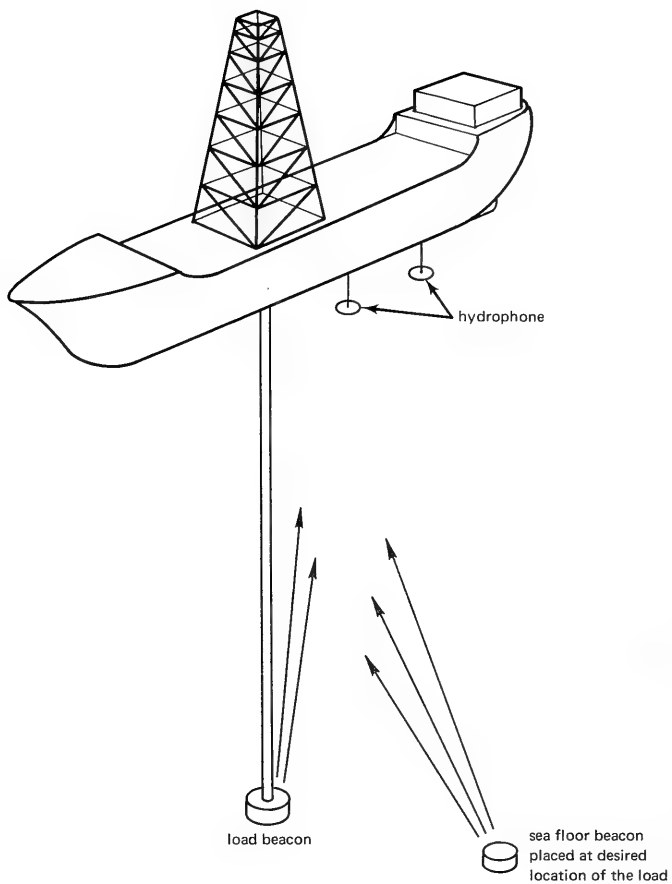

Figure 15. Dynamic load positioning system.

The details of this system are beyond the scope of this report; however, the system would not be too different from present positioning units. The entire operation would best be done automatically, perhaps by direct closed loop control of the entire positioning sequence. Areas worthy of future study are the optimal command-control tradeoffs necessary to determine the required data, the required calculations, and the best way to generate the correct response within the available time frame. At present, these factors are not adequately specified, nor can they be given a realistic assessment until the type of load, the required positioning accuracy, and the problem of interface coordination are analyzed.

ALIGNMENT SYSTEMS

In addition to mechanical systems for translating and rotating surface supported loads, accurate and reliable acoustic or visual networks are needed. They would supply feedback for making needed corrections in load alignment during final phases of emplacement. Several concepts have been investigated, including simple expedients such as manned observation (as passengers in a submersible or bathysphere) to more sophisticated robot systems featuring acoustic and laser targeting.

Good visual observation at 6,000 feet is dependent on such factors as water turbidity, lighting, and the sensitivity of photo-optical devices. Bottom sites where sediments can be easily stirred to create clouds of slowly settling debris are poor locations for the use of photo-optical devices (or the human eye).

Underwater Lighting

Three types of light sources are commonly used in underwater illumination: (1) the tungsten quartz iodide light, (2) the mercury vapor light, and (3) the mercury-thallium iodide light. Each has advantages for specific lighting tasks. The quartz iodide lamp, for example, is best for use in color photography since its light output, in the yellow and red region of the spectrum, tends to compensate for seawater absorption.¹⁷ The mercury vapor and the mercury-thallium iodide lights, both gas discharge lamps, provide much greater light output than incandescent lamps. This consideration coupled with the fact that the spectral output of these light sources very nearly matches the response curve of the standard vidicon tube makes them ideal to use with underwater television systems (Reference 17, p. 165).

Lingrey reports that tests with divers and underwater television systems have demonstrated the superiority of the latter from the standpoint of target image interpretation.¹⁸ The tests were conducted in shallow water under ambient lighting, and comparisons were made on the basis of contrast, resolution, and tone response. The general conclusion was that the subjective sightings of a television monitor technician ran about 30% better than the sightings of the diver (Reference 18, p. 57).

Accurate color rendition with underwater lighting is difficult except at close distances using quartz iodide lamps. Tests with 250-watt mercury vapor, thallium iodide and quartz iodide lamps demonstrated that practically all color rendition was lost at a distance of 3 meters from the light sources.¹⁷ Generally, yellow is the easiest color to distinguish underwater, followed by blue and green. Red should be avoided in underwater applications.

Underwater Television

Television offers some improvement over the human eye in both range and image contrast. In turbid waters, however, backscatter can limit usable television range to a distance of a few feet; in extreme cases to a distance of several inches. Backscattering is usually minimized by employing oblique lighting — placing the light source to one side and forward of the camera objective lens. Pulsed range gating using a laser light source offers some improvement in range over conventional vidicon systems.

Underwater Lasers

Terrestrial laser surveying and alignment systems have been used with great success. As a result, their use in similar applications under water has been suggested. Recent tests at NCEL with a diver operated laser transit indicate a usable range of about 150 feet. Tests were conducted in reasonably clear water. Laser range can best be extended by using pulse gated systems, and research in this direction is currently underway.

Guidelines

Advanced methods of subsea drilling have utilized guidelines for positioning wellhead systems on the ocean floor. Figure 16 is a drawing showing a longitudinal cross section of a typical drilling ship. The landing base and wellhead are lowered via the pipe string, thereby establishing the guideline system. The blowout preventer and various control systems can then be placed into position via the pipe string, guided by the guidelines. Usually, four guidelines are used.

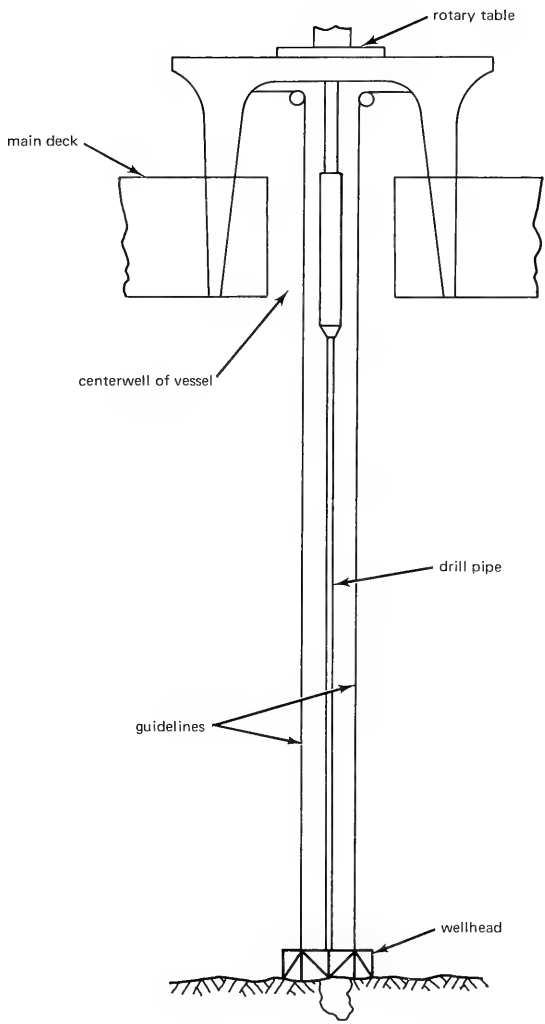

Longitudinal cross section through drilling ship.

Figure 16. Guidelines for positioning loads.

A tolerance of ± 9 inches is possible in positioning equipment utilizing the method illustrated in Figure 16. Most equipment placed through the use of guidelines have built-in guidance devices of simple design, the most common being a male-female cone arrangement. By careful design, practically any number of components could be assembled vertically using this approach.

The limitations of the guideline approach have been discussed with cognizant personnel. At present, an installation in water 1,000 feet deep is considered "ambitious." However, there is at least one guideline system in water 1,300 feet deep. Tangling has not yet been a problem in guideline installation, being avoided by ensuring that during the lowering operation a large tensile load is subjected to the lines to prevent slack which leads to line entanglement.

The use of guidelines has been limited almost exclusively to the deep-sea drilling industry. NCEL has plans to investigate a taut, wire guideline system to a depth of 1,000 feet, which is at the outer fringes of the state-of-the-art. As depths increase, the potential for tangling may become greater, thereby making extensions of the guideline systems to greater depths possible only if a system of spacers is devised to keep the lines separated. Obviously, these spacers would be fairly complicated if they could keep the lines from tangling while simultaneously allowing passage of the load.

An important point to consider is that guidelines dictate the form of the underwater unit more than any other positioning-guiding concept. If guidelines are to be used to help assemble a load or position it, a way to accommodate the guidelines must be designed into the load. This may or may not be convenient. Wellheads, for example, are suited for guideline assembly since they are invariably vertical structures consisting of components stacked onto each other. For other structures, a system of guidelines may be too complicated for efficient assembly, especially for underwater installations which may be built both vertically and horizontally. Thus, one must be cautious in recommending guidelines for assembly and positioning, since such a concept may be too restrictive to be used for all conceivable underwater construction tasks.

Acoustic Devices

As is true of virtually all electronic systems, the advances being made in sonar are rapid. The resulting short time to obsolescence, combined with the secretive nature of many development programs, make the state-of-the-art in sonar relatively difficult to assess.

Perhaps the best example of a presently available sonar unit with unclassified performance parameters is the AC-DRL Acoustic Guidance Sonar (AGS).¹⁹ The AGS is a high-resolution, echo-ranging sonar system capable of locating and displaying acoustically reflective submerged objects at ranges from less than 1 foot to 1,500 feet, in water up to 20,000 feet deep. Uses for the AGS include:

1. Reentry operations
2. Pipeline surveys
3. Bottom search and recovery operations
4. Object location and avoidance for unmanned submersibles.

A noteworthy advantage of the AGS system is that it can locate and display passive underwater objects. Devices such as beacons or transponders are therefore unnecessary, so the reliability and cost of these items are of no concern. Because the unit is self-contained, it can be used on any vessel or vessels. Moreover, since there is no need to mark the targets, it can be used to locate and identify any conceivable type of underwater structure at any time.

The resolution of this unit is exceptional and definitely would be of use for underwater positioning and guidance for near-future uses. For example, it would be possible to locate an object 6 inches on a side, 1,500 feet from the sonar scanner. An example of this high resolution is shown in Figure 17; the important features of Figure 17 are explained in Figure 18.²⁰ Figure 17 is a time exposure of the display of the AGS during a test in a 10-foot diameter wooden water tank at a depth of 10 feet. Noteworthy is blip No. 3, which is the sonar reflection from a No. 8-32 flathead wood screw, 1/4-inch long, and at a slant distance of approximately 4 feet. Assuming the pipe string supporting the sonar unit could be differentially controlled, it appears that the system could close on an object of this size — perhaps starting from as much as 1,500 feet away. An optical system could and most likely would be desired at this range. Nevertheless, there is sufficient evidence to conclude that even off-the-shelf sonar units such as the AGS are more than adequate for locating small objects. Indeed, it appears that the problem is really one of taking advantage of these sensitive sonar systems, since at the present time there is no efficient technique for effectively controlling either the sonar or, if need be, the target. Thus, the problem is one of designing the mechanical subsystems — the electronics are already more than adequate.

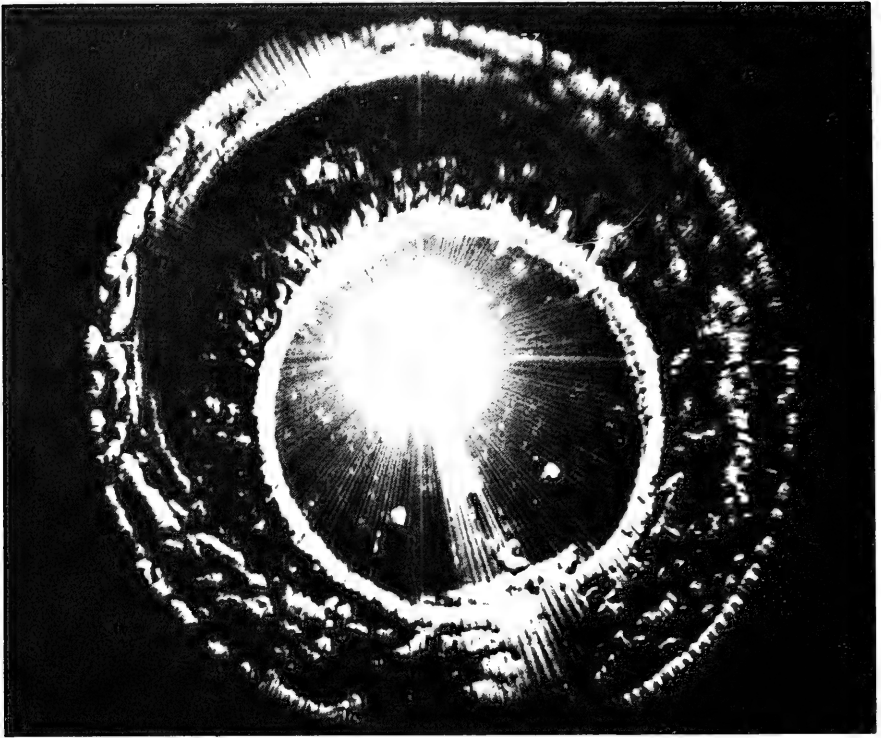

Figure 17. AGS display showing 10-foot diameter wooden water tank at a depth of 10 feet. (From Reference 20.)

CONCLUSIONS

Table 10 summarizes the findings of candidate load guidance and positioning systems. It is the judgement of the authors that positioning loads by movement of the surface support vessel is the most promising system for handling very heavy, negative loads at 6,000 feet. Modular loads would be positioned by this system in the following manner. A sea floor reference beacon will mark the bottom position for the first load. The beacon will direct the lifting vessel's dynamic surface positioning system to a station approximately above the chosen bottom site. The load will be lowered by

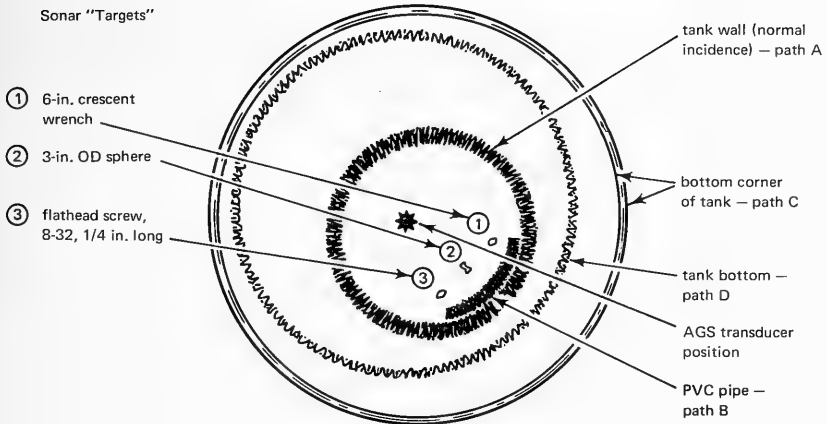
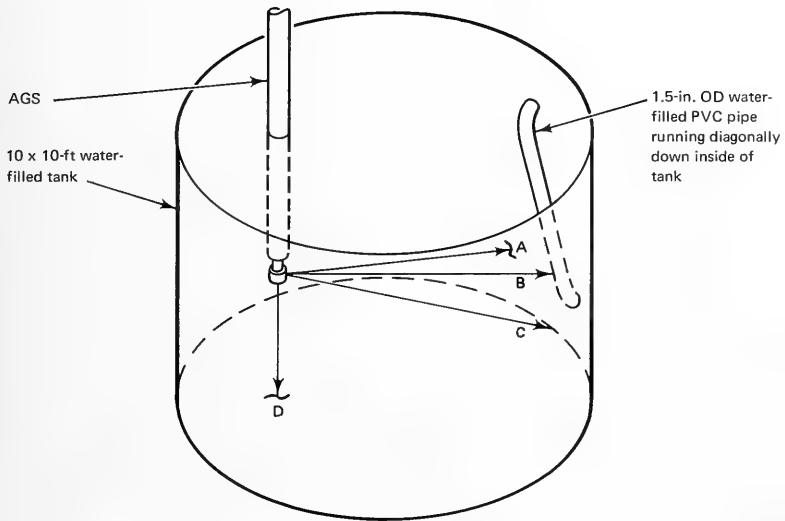

Figure 18. Interpretation of AGS display. (From Reference 20.)

Table 10. Candidate Load Positioning System

System	Compatibility With Cable Lift	Compatibility With Tubular Lift	Precision of Placement	State of Development	Other Comments
Submersible	No	Possibly	< 1"	At present, load position limited to very light loads at 6,000 ft; order of 100-200 lb.	High-thrust submersible will require major developmental effort. Power is most important limiting factor.
Bottom crawler	Possibly	Possibly	< 1"	Experimental and for shallow depths only.	Potential for relatively light load handling and positioning only. Stirs-up sediments and susceptible to becoming mired in bottom.
Guidelines	No	Possibly	< 9"	Currently used by oil industry to lower well heads to 1,300 ft. 2,000-3,000 feet possible near future.	Cable entanglement is a serious unsolved problem for deep ocean depths. More experimental data needed.
Bottom supported winches	Possibly	Possibly	< 1'	Submersible winches for diver personnel transfer capsule exist now. 6,000-foot winches within state-of-the-art.	Available power is limiting factor for use at 6,000 feet.
Surface supported winches	Yes	Yes	< 1"	Depth limit 2,700 feet now; 6,000 feet conceivable in near future.	Example is J-Star system. Loads currently limited to 5 tons. Some increase possible in future.
Positioning with surface vessel with sea floor beacon	Yes	Yes	1-2% of water depth w/o load mounted beacon With beacon mounted on load: < 1'	Operational to 18,000 ft. Experimental.	System used by drilling ship Glomar Challenger for maintaining station above drill hole.
Positioning with surface vessel with echo-ranging sonar	Yes	Yes	< 1'	Experimental; shallow water tests.	May be used by Glomar Challenger as drill hole reentry guidance system.

the suspension system (cable or pipe for 20- to 100-ton loads; pipe only for 400- to 600-ton loads) until contact is made with the sea floor. The initial load will be equipped with an acoustic beacon or it will be designed to have good sound-reflecting properties. For the former case, a sonar receiver attached to the second load (or to the end of the suspension system) will measure the relative displacement of the two loads and will instruct the surface vessel's dynamic positioning system to make appropriate position corrections. If the first modular load is not equipped with an acoustic beacon, the vessel position correction will be controlled by an echo-ranging sonar system similar to the one developed by the AC Electronics Corporation.

Both of these systems have merit for affecting "coarse" load positioning, i.e., alignment of loads to within several feet of each other. Final alignment will be monitored by a manned or unmanned submersible. The submersible will observe only and will make no attempt to translate or rotate suspended loads. The loads will have keyways, female/male connectors, or studs which will align and guide sections to form interlocking units.

The foregoing load positioning, guidance, and integrating system is within the current state-of-the-art. Further operational details are not warranted at this time due to the existing uncertainty regarding future undersea construction missions and load configurations. None of the other heavy-load positioning systems (high-thrust submersible, bottom crawler, guidelines, and bottom supported winches) are considered to have the potential for success exhibited by the chosen systems.

NEAR BOTTOM TRANSPORT SYSTEM

A need probably exists for a load handling system which would operate at or near the sea floor. Its principle mission would be to lift loads weighing 10 to 30 tons from the ocean floor, transport them to preselected construction sites, and accurately place them at the site. This system is conceived as a vehicle — self-sufficient, if possible, in both life support and power subsystems — which would evolve into the “tractor, fork lift, and crane” of future underwater construction programs. The kinds of loads to be carried by the transport subsystem would include: (1) trenchers, dredges, or drilling systems which lack the mobility to roam at will on the ocean floor; (2) transportable nuclear power sources which would provide power for habitats as well as for construction subsystems; (3) underwater winches and anchor blocks which would serve as components in sea floor construction systems; and, perhaps most importantly, (4) construction elements such as foundations, prefabricated concrete panels, and metal plates and girders to be used in building manned bottom installations. Construction materials could be stacked on pallets aboard surface vessels for easy off-loading by the Near Bottom Transport Subsystem (NBTS). The palletized load, weighing several hundred tons, would be lowered to the ocean bottom by the lifting/lowering subsystem and an acoustic beacon atop the load would guide the NBTS to the proper bottom site for rendezvous.

PERFORMANCE CRITERIA

A practical NBTS should meet certain cost and performance criteria. Some of these criteria previously specified as outlined in the DOT TDP²¹ are listed below:

Depth	6,000 feet
Load capacity	10–30 tons
Height of lift	20–100 feet
Transport capability	300–600 feet
Alignment tolerance (translation)	±0.1 – 0.5 feet

Alignment tolerance (rotation)	$\pm 1-3$ degrees
Attitude tolerance (vertical)	$\pm 1-3$ degrees

Undoubtedly, with refinements of DOT task objectives and load configurations, these criteria will be modified, but the authors feel that for the present study they represent a useful starting point.

To the above list can be added other desirable features for a feasible NBTS. For example, the system should be independent, as much as possible, from the lift system. For surface independence, power should be on-board; however, this may prove to be impractical due to the large power demand required for some systems. The NBTS should be capable of performing several lifts per mission in order to economize on bottom time. Some candidate systems will be launched from the surface, spend several hours on the bottom, and then return to the surface support vessel where the NBTS will be recycled for its next mission.

If manned, the NBTS should have certain fail-safe features. The passenger capsule, spherical or cylindrical, will be positively buoyant and separable from the remainder of the vehicle in the event of an emergency. Lift, whether provided by mechanical means or by vehicle buoyancy, should be controllable. The NBTS must at all times be near a state of neutral buoyancy, with or without a load attached, so as to prevent a sudden, disastrous ascent to the surface or an uncontrollable descent to the sea floor.

When operating near the sea floor, it is imperative that vehicles or devices do not stir up bottom sediments. Pelagic sediments, once disturbed, may obscure work sites for hours, weeks, or even years. Probably most work sites will not be located in areas where the softest sediments predominate, but the possibility of some vehicle induced turbidity is quite likely.

Cruising speed, range, and duration of candidate NBTS vehicles will depend, primarily, on available power sources. A bottom transport system should have a bottom time of at least 6 hours. This minimum time period will allow the NBTS to locate bottom resting loads, pick them up, and transport them to the desired site. Integral power will most likely be provided by batteries, lead/acid or silver/zinc, since fuel cells and nuclear sources are either at an early stage of development or are too costly. A range of several hundred yards and a speed of 1 to 2 knots is deemed adequate.

Vehicle response in attitude and horizontal and vertical alignment should be adequate to allow the precise positioning of loads. If manned, the operation of the NBTS must have visual access in all directions provided

by windows, television, or periscopes. Telechiric devices should operate with the maximum number of degrees of freedom possible so that the human masters can attach, position, and detach loads with dexterity.

Three basic approaches for achieving a workable Near Bottom Transport System are discussed in following portions of the report. One concept, an underwater helicopter (perhaps hydrocopter is more appropriate) would rely on mechanical means to generate the required lift. A heavy-lift submersible is considered to be another reasonable candidate system. Several alternate means for achieving variable ballast with such a submersible are described. A third choice is a bottom-crawling NBTS.

HEAVY-LIFT SUBMERSIBLE

A submarine capable of a 10- to 30-ton lift at 6,000 feet presents some unusual design problems, not the least of which is the development of a practical, variable deballasting system. Several possible approaches for supplying the ballast have been suggested and include:

1. Lift provided by syntactic foam, glass spheres, or gasoline filled containers.
2. Lift provided by high-strength steel pressure chambers maintained at a one atmosphere internal pressure.
3. Displacement of water ballast by gas produced from hydrazine or other gas generators.
4. Displacement of water ballast by a low-density gas such as helium stored in reservoirs at high pressure.

Concepts 1 and 2 are similar in design approach. Each vehicle is envisioned as having component parts consisting of: (1) a buoyant personnel sphere mounted on a structural steel framework (the sphere can be released from the vehicle in the event of an emergency); (2) battery packs to power the vehicle propulsion systems, interior and exterior lighting, telechiric devices, and winches; (3) lift buoys; (4) large, expendable ballast weights, and (5) a load attachment system. The two concepts differ in the choice of buoyant lift elements. One relies on the permanent buoyancy offered by syntactic foam or encased gasoline or other petroleum derivatives. This vehicle would descend to the sea floor carrying an expendable ballast weight,

probably concrete, which would compensate for the positive buoyancy of the foam or petroleum. Once on the bottom, the vehicle would search for the load, attach the lift gear to the load, drop the ballast weight (ballast weight and load weight are assumed equal), transport the load to the site where the vehicle would find another ballast weight placed there earlier by the lifting/lowering system, retrieve the new ballast weight, release the load, and then return either to the surface or search for another load. This load transport system has several serious limitations, perhaps the greatest being the possibility of rapid and hazardous ascent in the event that either the ballast weight or the load were detached prematurely.

The second concept differs from the preceding one in that positive ballast is provided by high-strength steel, external pressure vessels. These tanks could be HY-130 or HY-150 ring-stiffened cylinders with hemispherical end caps. The air-filled cylinders, sealed at the surface, would provide a net buoyancy equal to the submerged weight of the load. The vehicle would submerge with the aid of an expendable concrete ballast weight, pick up the load, jettison the ballast weight, and transport the load to the new bottom site. After carefully positioning the load in the proper attitude and alignment, the submersible would flood its ballast tanks until the submerged weight of the vehicle (excluding the weight of the load) was nearly neutral. With neutral buoyancy achieved, the submersible would detach the load, drop a small amount of fixed ballast such as lead shot, pig iron, or concrete, and return to the surface. This submersible differs in one important detail from the first system; it has the ability to control the buoyancy of its main lift tanks, and thus, is not dependent on finding and securing a second concrete ballast weight.

Both of the preceding heavy-lift submersible systems are dependent on somewhat unwieldy lift subsystems: in one case, fixed buoyancy provided by syntactic foam or other buoyant solids and liquids and in the other case, high-strength steel, external pressure chambers. If instead, a submersible carried a gas generator or a containment reservoir of high-pressure gas, buoyant lift could be created by displacing water from tanks with low-density gases. Whether filled with water or gas, the main ballast tanks would at all times be maintained at an internal pressure nearly equal to the surrounding hydrostatic pressure. Thus, the ballast tanks could be relatively inexpensive, thin-walled chambers having none of the fabrication and operational problems encountered with pressure vessels. Two approaches for the production of deballasting gas at 6,000 foot depths were considered: (1) the use of hydrazine or other reactant gas generators and (2) the use of a low-density gas, helium or hydrogen, for example, stored in reservoirs at high pressure.

A mission profile for this type of vehicle would be as follows:

(1) The vehicle, consisting of personnel sphere, propulsion system, lift tanks, and high-pressure gas reservoir (or gas generator systems), is launched from the support vessel; (2) the vehicle descends due to its slightly net negative buoyancy; (3) the lift tanks are open to the surrounding water at the sea floor, the submersible jettisons a small ballast weight and achieves near neutral buoyancy; (4) the submersible searches for, locates, and secures the load; (5) gas, stored at high pressure in spherical reservoirs, or produced by a gas generator, is allowed to flow into the lift tanks, displacing water and creating the force necessary to lift the load; and (6) the vehicle transports the load to the construction site. When the operators are certain that the load is aligned properly, vents are opened on the top of the lift tanks allowing gas to escape. The vehicle detaches the load, repeats its mission if there is sufficient gas left in the storage reservoirs, or returns to the surface by jettisoning additional lead shot or pig iron ballast.

Three conceptual designs for a heavy-lift submersible were studied. Two concepts employ the gas purging principle just described, while the other system relies on buoyant pressure chambers for lift.

Conceptual Design for a Helium Deballasting Vehicle

In this concept, helium, stored under high pressure, is used for deballasting water from the lift tanks. It was assumed that all candidate submersibles would be capable of at least a single 20-ton lift at 6,000 feet. Mission duration and maximum cruising speed were specified at 10 hours and 5.0 ft/sec, respectively. The conceptual design proceeded according to the following steps:

1. Estimate the vehicle drag force.
2. Estimate the total power requirement.
3. Estimate the weight and volume of the power source.
4. Determine the size and weight of the personnel sphere.
5. Design the two cylindrical ballast tanks.
6. Estimate the quantity of helium required.

7. Determine the size and weight of the helium reservoirs.
8. Estimate the amount of syntactic foam required to give the vehicle neutral buoyancy.

Detailed calculations are included in Appendix C.

The prototype submersible will have dimensions of approximately 40 feet in length, 16 to 20 feet in width, and a height of 6 to 8 feet. Dry weight will probably be in excess of 91,000 pounds. The submersible is dependent on a surface support vessel which will be equipped with means to launch and retrieve the submersible, track it during a mission, and have the on-board capability of charging the submersible's batteries and filling the high-pressure helium reservoirs.

With the exception of the helium reservoirs and associated valves and fittings, this concept represents application of current thinking. The detailed design of the reservoirs, however, will require special thought and consideration. Each of the 6-foot diameter spheres (five will be needed) will be welded from 2-inch thick plates of HY-130 steel. Pressurized at an internal pressure of 7,650 psi, the helium tanks will have a safety factor against rupture of about 2.0. This is a fairly small safety factor for high internal pressure vessels which undergo repeated cyclic loadings. The helium must be allowed to expand in the ballast tanks at a rate slow enough to prevent freezing of valves and water ballast. Further study will be required to estimate the magnitude of this problem.

Load attachment will be kept as simple as possible. Loads, whether power sources, equipment modules, or concrete foundation slabs, will be equipped with lifting eyes positioned above the mass centroid of the load. A hook, suspended beneath the submersible's centroid, will be used to engage the load lifting eye. Lifting arrays employing slings or multiple lifting points should be avoided due to the potential hazard of submersible entanglement.

The cost of the prototype heavy-lift submersible is estimated at \$1,500,000 exclusive of the high-pressure helium deballasting system. Cost of the latter is more difficult to estimate but a conservative figure would probably be on the order of \$250,000. Daily operating costs will probably be several times the cost of existing deep-diving submersibles. Gray reports that the operating cost of three such submersibles are as follows:²²

Westinghouse <i>DS 4000</i>	\$3,800/day
General Dynamics <i>Star III</i>	\$4,600/day
Reynolds <i>Aluminaut</i>	\$5,400/day

These cost figures include the operating cost of the surface support vessel.

Conceptual Design for a Hydrazine Deballasting Vehicle

This design differs from the preceding one in that the deballasting gas is provided by a hydrazine generator. The design is based largely on the results of a study conducted by the Naval Ordnance Test Station (NOTS) for an emergency deballasting system using liquid gas generators.¹⁰ The NOTS study requirements were for a system capable of displacing seawater at a rate of 100 lb/sec. Total volume to be displaced was 210 ft³ (equivalent to a lift of about 8 tons) at an ambient pressure of 3,550 psi (8,000 ft). Correcting the NOTS data for a hydrazine system using 5% ammonia, for an operating depth of 6,000 feet, it was found that:

1. 690 ft³ of water must be displaced for each 20-ton lift.
2. At a fuel density of 61.9 lb/ft³, 5,230 lb of hydrazine fuel are required.
3. At a deballasting rate of 100 lb/sec (7 minutes total time required for a 20-ton lift) a 12-horsepower pump will be needed.

The choice of hydrazine gas generation over stored helium for variable ballast control has several operational advantages. First, the dry weight of the hydrazine generator including fuel, pump, and catalyst bed is likely to be lower in weight than the helium reservoirs, thus simplifying vehicle handling at the surface. A serious problem with the stored helium system is the hazard presented by the high-pressure reservoirs which are subject to impact damage during launching and through fatigue failure due to repeated cyclic loading of the tanks.

On the debit side, however, hydrazine gas generators produce dangerous gaseous end products: hydrogen and ammonia. Although the mission profile calls for "dumping" deballasting gas at the sea floor, an alternate mission where the lift vehicle brings loads to the surface, would require retention of the lift gases (allowing, of course, for venting of excess gas due to expansion). Hydrogen in contact with atmospheric oxygen is a hazardous mixture. The hydrazine generator is a developmental item. Its feasibility will depend on several years of research and development effort. Additional information on the hydrazine gas generator system is included in Appendix C.

Conceptual Design for a Vehicle with Rigid Lift Tanks

This design is similar to the preceding two, except for the ballasting system. Two ring-stiffened cylinders constructed of HY-130 or HY-150 steel, sealed and filled with air, provide the required 20-ton lift capacity. Design details are included in Appendix C. An expendable 20-ton concrete ballast weight must be carried by the vehicle until the load is secured. The ballast weight is then dropped (the load now serves as ballast) and the lift vehicle proceeds to the construction site. Upon arrival at the site, the vehicle pilot carefully positions the load, partially floods the lift tanks such that the submerged weight of the vehicle minus the load is near neutral, detaches the load, and proceeds to the surface.

The vehicle operator must be especially careful that he does not dump the ballast weight or detach the load prior to readjusting the vehicle buoyancy to a near neutral state. Failure to do so will result in an abrupt, hazardous ascent. After positioning the load at the new site, the operator must be certain that he does not overflow the lift tanks, an oversight which could result in the loss of the vehicle. In the latter emergency, the personnel capsule could be jettisoned and its inherent positive buoyancy would insure return to the surface. The problem of overflowing the ballast tanks could be avoided if the vehicle carried sufficient fixed buoyant material to compensate for the deadweight of the fully flooded tanks. This design would also require an expendable ballast weight of approximately 40 tons — twice the weight as before. It is assumed, here, however, that ballast tank flooding can be accurately monitored and controlled by the vehicle operators, thus resort to the heavier and more costly “fail-safe” design is not necessary.

Conclusions

Table 11 compares features of all three competing, heavy-lift submersibles. Each of the three submersibles discussed has serious design, developmental, and operational problems. Development of the high-pressure helium vehicle places considerable strain on current and near future capabilities in pressure vessel fabrication. The five 6-foot diameter tanks will be vulnerable to damage during launch and retrieval or to accidental impacts while transporting loads at the sea floor. With the development of higher strength steels and titaniums, more compact and safer vehicles could be designed.

Table 11. Comparison of Candidate 20-Ton-Lift Submersibles

Vehicle	Approximate Dimensions (ft)	Dry Weight (lb)
1. Deballasting with hydrazine	30 x 18 x 8	50,043
2. Deballasting with high-pressure helium	40 x 18 x 8	91,003
3. Lift provided by buoyant, rigid chambers	45 x 20 x 8	117,470 (46,720 lb w/o ballast weight)

A vehicle employing buoyant, rigid lift tanks is the simplest in concept although it does have one detracting feature: the need for a heavy ballast weight (also large in size if made from concrete) which must be jettisoned after load attachment. Also, the dry weight of the rigid-chamber vehicle is the greatest of the three candidates.

A detailed design of the three heavy-lift vehicles was not attempted, so it is questionable whether each candidate has equal demands on a structural frame to support vehicle subsystems (each conceptual design assumes a 4,000-pound framework). The hydrazine vehicle is seemingly the most compact and lightest in weight. Its gas generator system, however, demands performance capabilities which are not now achievable even in the laboratory. Presumably, an urgent requirement for such a vehicle — with appropriate funds in support — would go far toward eliminating current shortcomings in performance.

Based on their limited review of the subject, the authors are convinced that a 20-ton-lift submersible operable to a 6,000 foot depth is a possibility, but will require considerable investment in resources — both in time and money. The rigid chamber vehicle and the vehicle using high-pressure helium for water deballasting are considered to be somewhat inferior in potential to the hydrazine vehicle. A considerably more detailed study is needed, however, to confirm this suspicion. Future studies might also explore the possibility of using the candidate vehicle concepts for lifting much lighter loads in both deeper and shallow water.

HEAVY-LIFT BOTTOM CRAWLER

At the outset of the present study, two design approaches seemed promising for conceptualizing a feasible bottom crawler with a 20-ton lift capacity. One, a tracked or wheeled vehicle with personnel sphere, lifting gear, power, and propulsion system, would depend on counterweight (or other restraint) to balance the load overturning moment. This design would incorporate a crane, A-frame, or fork lift at the forward end and a fixed (or jettisonable) counterweight at the rear. This concept, however, was found impractical for many potential sea floor construction sites. Pelagic soils are typically soft, oozy sediments with minimal bearing strength. Preliminary analysis showed that a bottom crawling vehicle, weighing at least 20 tons and equipped with any one of several wheel and track configurations, simply could not maneuver in soft ocean sediments.

Another approach was considered whereby the vehicle would be designed to have near neutral buoyancy at all times while operating on the ocean floor. After securing the load, a deballasting system would provide the increased lift needed to make the vehicle/load system once again near neutral buoyancy. Actually, the vehicle would probably operate in a slightly negative buoyant state in order that it remain affixed to the bottom. Powered, cleated wheels or tracks would provide the needed tractive force.

Several disadvantages of the foregoing concept can be enumerated. First, the vehicle is likely to be a greater consumer of power than competing systems such as the heavy-lift submersible previously discussed. A bottom crawling vehicle is likely to stir-up sediments, possibly obscuring and quickly bringing to a halt any prolonged underwater construction projects. There is also an ever present danger of getting stuck in the ooze and having to abort the mission, risking both the vehicle and its human occupants. Lastly, the variable deballasting crawler is little more than a heavy-lift submersible in disguise, albeit a more heavily powered submersible with wheels or tracks attached to its undercarriage. Although the crawler has some of the advantages offered by the pure submersible, it also has many more operational disadvantages. The latter are largely a result of the crawlers necessary contact with the ocean floor.

The authors see no point in considering a bottom crawling vehicle as a serious NBTS candidate. They are not implying, however, that bottom crawlers have no role in undersea construction. Possible applications for bottom crawling vehicles might include:

1. Exploratory vehicles for testing sediments and mapping bottom topography.
2. Trenchers and dredgers for laying power and utility lines.

HYDROCOPTER

The final NBTS candidate is a system which depends on mechanical thrust for lift. This concept has been discussed before by Beno and Clark and in a study done under contract by the Bechtel Corporation.^{23, 24} Such systems are usually thought of as having one or more vertical axis propellers and are invariably labeled as underwater helicopters or "hydrocopters."

After considering various propulsion and power systems, the authors decided that an underwater helicopter had potential as a heavy-lift vehicle. Any system dependent on mechanical means for generating 20 to 30 tons of thrust will inevitably be a large power consumer. The only practical way of supplying enough power would be through an electrical conductor from a remote power source, either at the surface or in the ocean floor. This is thought to be feasible.

Conceptual Design

Hull Configuration. A toroid hull was chosen since it appeared to offer the most efficient shape for a hydrocopter vehicle. The artist's sketch in Figure 19 shows a toroidal hull vehicle hovering above the sea floor. Figure 20 is a more detailed plan drawing which illustrates most of the principal vehicle design features.

A personnel sphere is accommodated in the toroid center "hole." It could be constructed from high-strength steel or titanium, or possibly manufactured from a titanium-glass composite, rigid titanium frame with large glass units, thus affording excellent viewing for the vehicle pilots. The sphere would be buoyant and detachable in the event an emergency prevents recovery of the entire vehicle.

Three, nearly cylindrical, ring-stiffened pressure hulls provide sufficient permanent buoyancy to compensate for the deadweight of other vehicle subsystems. In the event of power failure, the hydrocopter, which is near neutrally buoyant, would ascend by jettisoning a small amount of expendable ballast.

Propulsion System. After a trade-off study of candidate propulsion systems, it was decided that cycloidal propellers offered the greatest possible efficiency and versatility. Cycloidal propellers consist of circular rotary platforms to which are affixed several movable blades. The platform generally rotates about a vertical axis. Once forward movement is initiated, oscillating movement of each blade about its own axis, coupled with the uniform platform rotation, produces a cycloidal blade path.

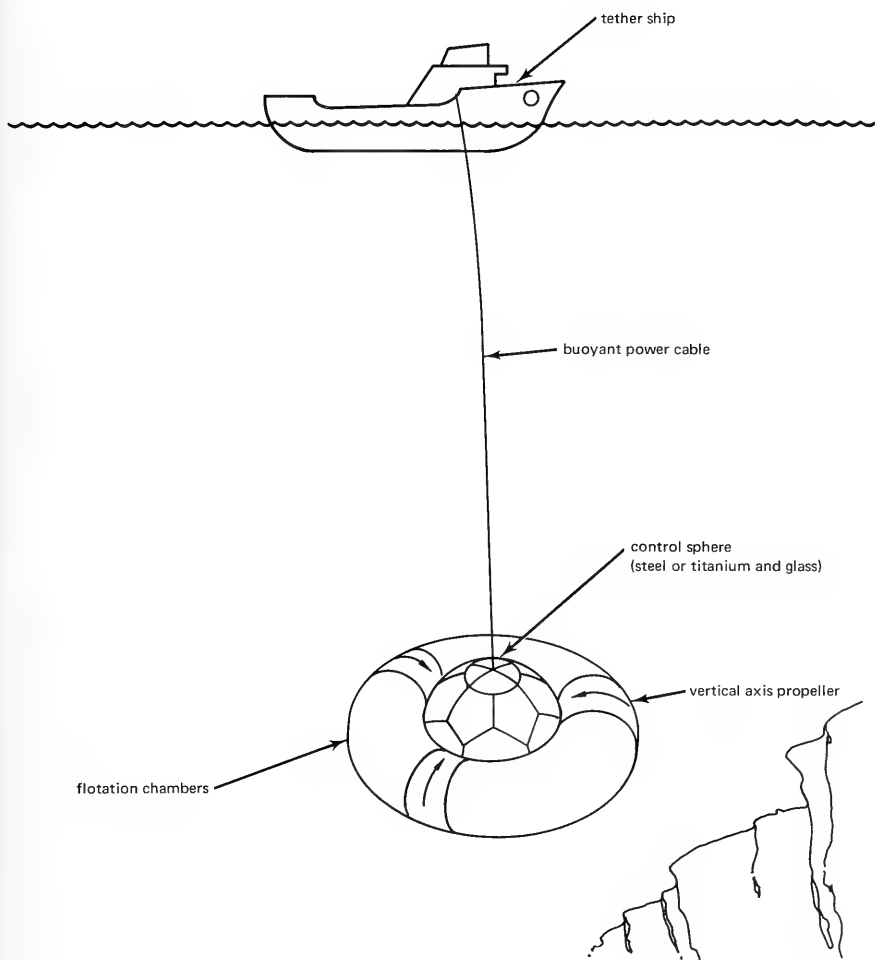

Figure 19. Hydrocopter lift vehicle.

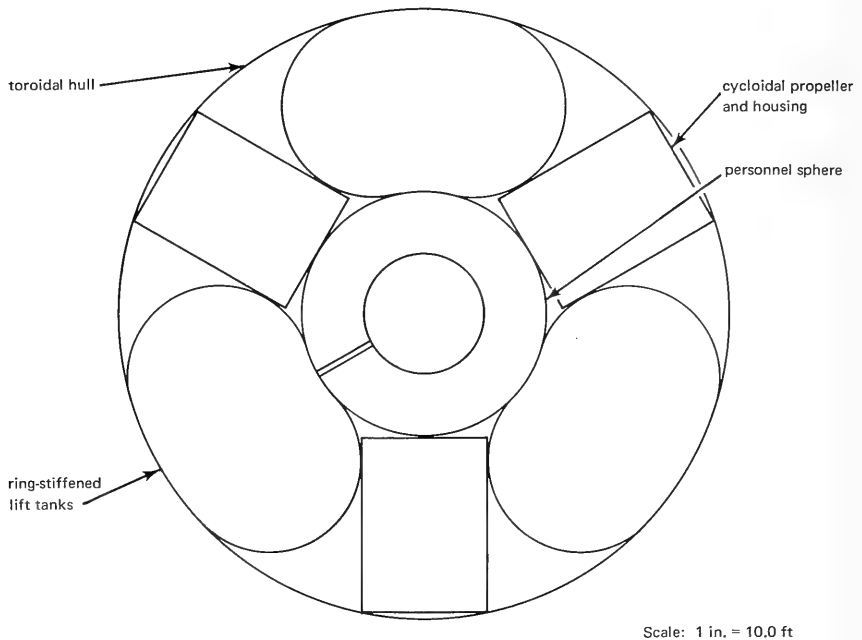
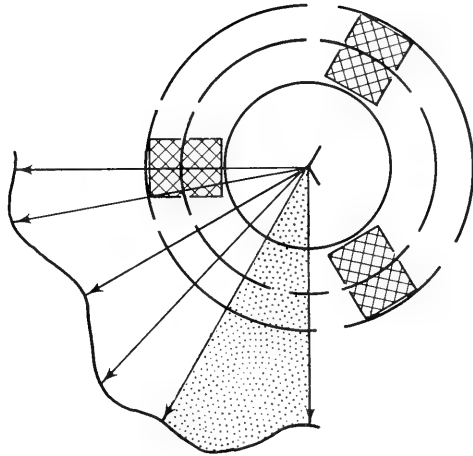

Figure 20. Plan view of hydrocopter.

The principal advantages of the cycloidal propeller over the more conventional variable and fixed pitch propellers are that the former is capable of thrust modulation (without change in engine rpm) and has the ability to direct the thrust in any direction of the rotor plane.

Three Voith-Schneider Model 24E cycloidal propellers with a static thrust rating of 20,000 pounds are each powered by a 1,000-horsepower horizontal induction motor and will provide lift and lateral thrust. Diagrams for both lift and lateral thrust are shown in Figure 21.



horizontal distribution of force
(vertical thrust = 0)

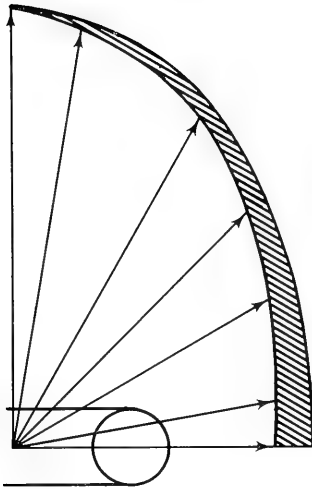

maximum force in the vertical plane

Assumed neutrally buoyant
Scale: 1 in. = 20,000 lb

Figure 21. Thrust diagrams for hydrocopter.

Power System. Conventional integral power sources such as lead/acid and silver/zinc storage cells are impractical for providing the power needed to drive the electric motors. Consequently, a surface supported, air breathing generator would provide power to the hydrocopter via a buoyant electrical conductor.

Miscellaneous Considerations. As is the case with the heavy-lift submersible, the hydrocopter would have a load lifting system. It should be simple in design and operation. A single hook, jettisonable in event of an emergency, is one possible solution.

A surface support vessel will be needed which is capable of lowering and lifting the hydrocopter into and out of the sea. For short distances, perhaps the hydrocopter can be towed to the offshore construction site. A more detailed discussion of the hydrocopter can be found in Appendix C.

Compared to the heavy-lift submersibles previously discussed, the hydrocopter is much heavier (dry weight in excess of 250,000 pounds), bulkier (overall diameter of 41.0 feet), and dependent on a surface power supply. The principal advantage of the hydrocopter is its considerable lateral thrust capacity which could be used to augment the prime, surface supported, load positioning and guidance system.

CONCLUSIONS

Three basic approaches for achieving a 20- to 30-ton lift at 6,000 feet have been discussed. One approach, employing a bottom crawling vehicle, has been discounted altogether — at least for loads of this magnitude. The remaining concepts, heavy-lift submersible and hydrocopter, however, appear to have potential as heavy load lifters.

The hydrocopter not only is capable of lifting heavy loads (up to 30 tons), but also has substantial lateral thrust capability. The latter would be an important consideration for load positioning. The hydrocopter could conceivably function in concert as a work monitor with the tubular support or cable lifting-lowering system. If needed, the hydrocopter NBTS could also use its considerable thrust to assist in translating heavy, suspended loads to the proper bottom construction site. The principle disadvantage of the hydrocopter is its dependence on an external power source. Power would be provided by surface generators through one or more electrical conductors. Such conductors, made buoyant if possible, could entangle in the lifting-lowering suspension system or break due to a sudden downward movement

of the hydrocopter. A power failure most certainly means an emergency ascent of the entire vehicle, while cable entanglement could result in jettisoning the personnel capsule and possible loss of the remainder of the lift vehicle.

A heavy-lift submersible using a hydrazine gas generator for displacing water ballast was considered to be the most likely candidate of the three possible submersible vehicles. Although capable of lifting 20-ton loads from the sea floor and transporting them to new bottom sites, the heavy-lift NBTS has only slight lateral thrust capability. Its propulsion system, unlike the one aboard the hydrocopter, is dependent on an internal power source. However, its internal power source means that the heavy-lift submersible is free from the hazards created by long surface-to-vehicle conductors. Stirring-up of bottom sediments, a problem endemic to the hydrocopter, is less likely to be as serious with the submersible. Both vehicles would require a surface support craft. Because of its greater weight and bulk, the hydrocopter's support craft would be somewhat larger than that required for the submersible.

Further and far more detailed studies of both the hydrocopter and submersible are necessary before deciding on the proper approach to a workable NBTS. An important consideration, and one not discussed in great detail here, is definition of the NBTS work mission. Proper mission description must await further refinement and definition of DOT goals. As discussed earlier, the NBTS is conceived as a work system for transporting other, nonmobile work systems, portable nuclear power sources, and anchorage systems, perhaps all of which are components of second or third generation construction missions. The 20- or 30-ton lift requirement, assumed here, is based on pure speculation as to the upper weight limit of portable bottom loads. Lighter or heavier loads (also their bulk and sensitivity to shock loading) will certainly be determining factors in the future selection of near bottom transport vehicles.

For the present, nothing more will be concluded except that either a submersible or hydrocopter with a 20-ton lift capability is probably possible within the present state-of-the-art. Such systems will be costly initially (several millions of dollars), costly to operate (probably two or three times as much as conventional deep-diving submersibles), and fraught with certain operational hazards for both crew and vehicle.

CONCLUSIONS

Lifting and Lowering

1. The use of pipe to suspend, lift, and lower loads is the most feasible method of those considered for satisfying the goals of the heavy-lift project. An acceptable system would most likely resemble the mobile offshore drilling vessels presently operating in many parts of the world.
2. The surface vessel required for support of a heavy-lift system can be either a ship or platform. The characteristics of these vessels generally have little influence on the performance of the lift systems considered in this study.
3. The feasibility of using cable to suspend, lift, and lower loads weighing greater than 100 tons to depths greater than 1,000 feet is judged to be significantly less than for pipe.
4. An effective and efficient method of supplying buoyancy to very large loads poses unsolved problems.
5. Lowering and raising 200 tons to 6,000 feet will be a near-term capability. At least one commercial vessel will have the capacity to perform this task in the very near future; drill pipe will be used as the suspending medium.

Positioning and Guidance

6. Positioning suspended loads by displacement of the surface support vessel is the most feasible means for coarse alignment at depths to 6,000 feet.
7. An echo-ranging sonar system or a system comprised of an array of sea floor acoustic beacons with a load-mounted receiver, are considered the most promising approaches for guiding the surface support vessel during emplacement, and are commercially available.
8. Fine alignment and integration of modular loads can best be achieved through the use of keyways, studs, or other load guide appurtenances.
9. A manned, deep diving submersible could serve as a positioning and guidance backup system supplementing, if need be, alignment corrections provided by the prime acoustic guidance system.

Near Bottom Transport

10. A system for transporting 10- to 30-ton loads for short distances in the near bottom environment is considered feasible.

11. The two most promising concepts are a submersible with a gas generator for displacing water ballast and a hydrocopter, dependent on mechanical means for generating lift.

12. Final choice between the two concepts must await further definition of work missions and load configurations.

Appendix A

SURFACE VESSELS

Specifications and costs of available and/or desirable surface vessels for heavy-lift systems are discussed in this appendix. The three general classifications of surface vessels, their assets and liabilities, and any additional points of interest are given consideration.

A portion of the appendix is devoted to a specific but important topic related to operations employing surface vessels: the problem of maintaining position on the surface during an operation. The possibilities of using a conventional anchoring system or a dynamic positioning system are discussed.

SURFACE VESSEL TYPES

There is a large number of trade-offs to be considered before the more desirable types of surface vessels can be chosen. It is convenient to define three general types of floating vessels: surface, semisubmersible, and submersible.

1. Surface Type. A surface-type vessel is characterized by having most of the hull near the water surface. Any ship could be considered a "surface-type" vessel. These vessels are designed so the center of gravity is below the metacenter. The stability is dependent upon the amount of mass initially above the water line and its location with respect to the center of roll. Vessels of this type, namely ships, have short beam dimensions when compared to their length, making them susceptible to roll.

2. Semisubmersible Type. Semisubmersible vessels have reduced roll and pitch which result from increasing the natural periods of these ship motions. The latter are achieved by placing large masses significant distances from the center of roll. Much of the added mass of the hull is below the water surface, although some of the hull is still above the water surface.

3. Submersible Type. The hull of a submersible vessel is completely below the water surface. To provide stability, the structure must usually be ballasted; if it were not, the center of gravity for most geometric shapes would be above the center of buoyancy and a very unstable vessel would result. These vessels have very deep drafts when in the operational mode.

All of the above mentioned types of surface vessels have been built. The submersible units are more stable and, therefore, have fewer restrictions on the limits for safe operation. The surface-type vessels are more common, of course, and have proven to be very successful in offshore oil well drilling. For simplification, the surface-type vessel will be called a "ship" and the semisubmersible and submersible will be called "platforms" in the following discussion.

A surface vessel meeting the requirements for the heavy-lift operation could be designed to be any one of the three types described. Each has its own advantages and weaknesses. For the project under consideration, it is important to study the following factors.

Availability. There are many ships suitable and available for conversion to heavy-lift operation. There are very few, if any, platforms suitable for heavy-lift operations. The latter would undoubtedly have to be custom-built.

Ease of Construction. There is much more experience in building ships than platforms. The result is that it is easier to design and build an acceptable ship; it is also easier to estimate the total cost. The limited experience in designing and constructing platforms has made this type of vessel relatively expensive to build. Shipyards are not designed for constructing platforms, nor are many of the personnel familiar with the construction procedures. In addition, special facilities are needed for alterations or repair of platforms; this is particularly true if drydocking is required.

Mobility. Ships are more mobile than any platform yet built. Many platforms have no means of propulsion and must be towed by a tugboat between work sites. Up to the present, there has been no need for a platform which has its own propulsive power, the only requirement being that it is safely towed. Towing speeds are on the order of 6 to 8 knots.

Platforms can be designed to accommodate a propulsion system. A large amount of power is required to move a platform since the hull configuration is not the best for movement through the water. It can be safely assumed that unless a tremendous (almost unrealistic) amount of power is provided, a platform is considerably slower than a ship.

Stability. The stability of the surface craft is very important. Platforms are inherently more stable than ships in every response mode; this is the main reason they are used. Large ships are fairly stable under most sea states and would be acceptable if a restricted range of operating environments is acceptable.

Accommodations. The amount of space available for equipment and personnel is an extremely important factor. Small ships are out of the question for this project simply because they do not have enough room for all of the equipment needed for a cable system or pipe string and derrick system. Larger ships may be large enough to accommodate the derrick and pipe string or cable equipment, but there are some limitations on the size of the load.

Platforms are considerably larger than ships. They are clearly superior to ships in that they are not restricted by beam width and deck space. Moreover, it is much easier to build a platform with a large centerwell; for a ship there is obviously a restriction on how large the well can be. For example, the *Glomar Challenger* has a beam of 65 feet, yet the well is only 20 by 22 feet.

It is apparent that as the load increases in size, the feasibility of using a ship to transport and lower it decreases accordingly. Much larger loads can be transported on and lowered from a platform. However, this is important only if it is necessary for the lift system to be self-contained. It is planned, for instance, to use the *Glomar Challenger* to lift loads larger than the 20 by 22 foot well by transporting the load in a separate barge, which will lower it under the *Challenger* where the pipe string can be attached. While it is desirable to keep the operation down to one self-sufficient ship, the size limitations of a ship's centerwell can be overcome, if necessary, by transporting the load in a suitable barge.

Type of Operation. There appear to be two general types of operations which could be encountered in heavy-lift operations: (1) fast placement or recovery of objects on the ocean floor or (2) a test operation where a subsea system or component is held at depth for testing (similar to the *FORDS* platform). As far as the surface vessel is concerned, these distinctly different operations are not compatible. For the first type of operation, i.e., lowering or recovery, a ship would be satisfactory — assuming the crew were given some leeway in the timing of the operation. For the second type of operation, simply holding a test specimen, there is probably

no choice but to use a platform since the test could take some time and the support craft will have to be capable of withstanding the severest sea states. In this respect, the platform is more versatile since it can perform both types of operations.

It has been stated that the present underwater search and recovery systems are seriously limited by the sea state; this is particularly true of submersibles. As a result, it is certain that the Navy will be particularly interested in the ability of any proposed heavy-lift system to operate in heavy seas.

A second requirement for any system used by the Navy is that it be readily deployable. The importance of portability was demonstrated in the H-bomb recovery operations off the coast of Spain. In that particular situation, it took entirely too long to gather all the necessary equipment for the operation; some of the recovery vessels were not easily transported to the scene, and many of the ships were slow in arriving. This problem can be solved in part by improving the organization of the operations. However, there were some serious limitations imposed on the project by the equipment used. In particular, the use of submersibles can significantly increase the total elapsed time of the operation. Thus, it is apparent that an acceptable heavy-lift system will have to be readily deployable.

It is easy to conclude that the type of operation anticipated for the heavy-lift system will have the greatest bearing on the configuration of the surface vessel. Unfortunately, a vessel which can operate in rough seas, like a platform, is not as readily deployable as a ship. However, the larger ships will operate successfully in any common sea state; only in the severest seas, for example a high sea state 6, will a ship not be safe to operate.

COST OF SURFACE VESSELS

Next to feasibility, the most important quality of a system is economy. Although a surface vessel may be technically feasible and acceptably reliable, it could also be too expensive. Usually the least expensive system is the best of all feasible systems. This fact demands that attention be given to the cost of construction or development of a system.

There is some difficulty in realistically comparing the cost of converting a *T-2* tanker, which has been done many times, with the cost of designing and constructing an entirely new platform. Experience is the best guide for a situation such as this, so it is necessary to rely heavily on actual construction costs of similar systems such as the *Mission Capistrano* or *Cuss I*. In any event, accurate cost estimates are particularly important when

comparing a system of superior operational capabilities with one of more restricted capabilities, since choosing the superior system can be justified only if the improvements in performance are commensurate with the increase in cost. Any error in cost estimates can, therefore, be misleading and lead to a false engineering decision.

There is no guideline available for estimating the construction cost of a platform, primarily because there have been few platforms constructed. For ships, it has been found that the cost per ton is a minimum of about \$1,600 for a cargo vessel and a maximum of \$3,000 for special research ships. The cost of a platform is probably comparable to that of a new ship. It is estimated that a cost of \$2,400 per ton for the platform is realistic, and the cost for a new ship would be about the same. Converting an old ship for heavy lift would cost roughly \$500 per ton, although a price of as much as \$1,000 per ton could result if extensive reworking is needed.

Table A-1 presents the approximate dimensions of the ships under consideration. Also included are order-of-magnitude total cost figures which require some explanation.

T-2. The **T-2** tanker is discussed in detail in Appendix B in the section on ship motions. The total cost is based on extensive modifications, including a new center section. Assuming no initial cost to purchase the ship, the cost breakdown is as follows:

Shipyards modifications	\$3,300,000
Preparing and approving plans	300,000
Positioning and sensing equipment	120,000
Electronics	350,000
Steering screws	400,000
Power equipment	<u>200,000</u>
Total	\$4,670,000

C-2. The **C-2** is a general cargo ship which would require only minor modifications for strengthening. The cost breakdown is as follows:

Shipyards modifications	\$1,800,000
Preparing and approving plans	250,000
Positioning and sensing equipment	120,000
Electronics	350,000
Steering screws	400,000
Power equipment	<u>700,000</u>
Total	\$3,620,000

Table A-1. Design Parameters of Various Surface Vessels

Parameter	Vessel				
	T-2 ¹	C-2 ¹	ARD ¹	C1-M-AV1 ¹	FORDS ²
Length (ft)	523	459	489	338	204
Beam (ft)	68	63	81	50	204
Depth (ft)	---	---	---	---	488
Draft (ft)	30	35	15	21	265
Displacement, Full (long tons)	21,900	13,850	14,000	7,500	43,000
Displacement, Light (long tons)	8,500	4,640	10,000	3,200	31,000
Speed, Still Water (knots)	15	15	4	10	No power
Total Cost (\$1,000)	4,670	3,620	3,785	2,820	16,013

¹Design of a Deep Ocean Drilling Ship, NAS-NRC Report No. 984, 1962.

²J. Ray McDermott and Co, Inc., FORDS, Contract No. NBy-37640, April 1964.⁷

ARD. The **ARD** is a floating drydock which requires large docking facilities for service. It is a slow vessel which would require much more time for transit between job sites. The cost breakdown is given below:

Shipyard modifications	\$1,925,000
Preparing and approving plans	290,000
Positioning and sensing equipment	120,000
Electronics	350,000
Steering screws	400,000
Power equipment	<u>700,000</u>
Total	\$3,785,000

C1-M-AV1. The **C1-M-AV1** is a cargo ship owned by the Maritime Administration. Its response characteristics are discussed in some detail in Appendix B. The **C1-M-AV1** was to be used as a test bed for the MOHOLE Project. The costs are as follows:

Shipyard modifications	\$1,330,000
Preparing and approving plans	200,000
Positioning and sensing equipment	120,000
Electronics	350,000
Steering screws	220,000
Power equipment	<u>600,000</u>
Total	\$2,820,000

FORDS. The **FORDS** concept, discussed earlier, was studied in some detail. J. Ray McDermott and Company, Inc. designed the platform and itemized the costs in a detailed summary duplicated below:

Design, inspection of station	\$1,187,000
Fabrication of structural components and corrosion protection	5,968,000
Hydraulic jacking system	796,000
Electric power generating units	1,383,000
Auxiliary propulsion units	1,300,000
Emergency ground tackle units	1,300,000
Operation subsystems	3,884,000
Navigation and communications	396,000
Quarters area	278,000
Solid ballast	383,000
Test and checkout	<u>80,000</u>
Total	\$16,013,000

The total cost of the *FORDS* concept includes everything except the cost of cable (or pipe string). The costs of the cable and cable handling equipment (or pipe and pipe handling equipment) must be added to the costs of all the above systems.

It is important to consider the limitations of the above surface vessels. Except for the platforms, there are serious restrictions on the size of the load that can be handled. The ships are relatively narrow and, as a consequence, the outside dimensions of the load will be restricted accordingly. Moreover, there is some question whether some of the smaller ships are large enough to accommodate even the equipment to lower the load, especially if a derrick of adequate size were required. Based solely on the criteria of versatility and size, a custom-built platform would be the most satisfactory.

As emphasized in the opening paragraphs of this appendix, economy of construction cannot be ignored. It is obvious that the ships offer the least expensive means of constructing a heavy-lift system, since they are only to be modified. Even if an entirely new ship were to be constructed, there is a good possibility that the total cost would still be less; the *Glomar Challenger*, for example, cost \$12.6 million.

Another factor which should be kept in mind is that the *FORDS* platform is probably more than is needed. It was designed to spend many days at sea, be self-sufficient, and survive the severest seas. It seems logical to suppose that the heavy-lift system will not be required to satisfy such stringent requirements; in other words, that the crew will have some choice as to when they can lower or lift a load. How closely the final system resembles the *FORDS* platform or the *Glomar Challenger* depends greatly on the scenario of the desired operation. A fast, mobile system will require a ship-like hull, while a system which requires less mobility could be configured as a stable platform.

MAINTAINING POSITION OF THE SURFACE VESSEL

Mooring

There are three main classifications of major mooring systems: (1) single-leg flexible, (2) multileg flexible, and (3) bottom-rest. Brief descriptions of these systems are given below.²⁵

Single-Leg Flexible Anchors. A single-leg flexible anchor consists of one anchor and a single slack riser line to the surface vessel. It is the most common form of anchorage and is used primarily to resist horizontal loads.

A typical single-leg flexible anchor also incorporates a weak link near the anchor to permit recovery of practically the entire line in case the anchor snags.

The single-leg flexible anchor is used to secure a ship for relatively short periods of time. The ship can drift considerable distances, conceivably to any point in a circle where the center is directly over the anchor and the radius is equal to 1.3 times the depth.

The USNS *Josiah W. Gibbs*, a 2,800 ton vessel, has been anchored in depths to 18,000 feet with a single-leg flexible system. In one instance the ship, anchored in 18,000 feet of water, did not experience any discernible drift in winds of 37 knots. The cable was 6 x 19 galvanized plow steel with a wire rope core. Significant here is the fact that the anchoring system was subjected to a thorough mathematical analysis — nothing was left solely to experience. Unfortunately, there is nothing in the literature which reveals whether this particular anchoring is typical; it would appear that it is not.

Multileg Flexible Anchorage System. It is evident from the literature that anchorage systems employing more than one leg are needed to achieve a sufficient degree of permanency for surface vessels. Multileg systems are fairly complex in shallow water and the complexity increases "at a geometric rate with depth." (Reference 25, p. 4.15.) As of late 1965, the maximum depth for a permanent installation of this type was felt to be in the neighborhood of 500 feet. Little has happened since that time to alter this situation.

A noteworthy example of a deep-mooring system is TOTO II. It is a three-legged mooring in 5,500 feet of water. This installation is quite involved and requires considerable amounts of time and support to accomplish. In the TOTO II system, a cruiser size vessel can be held on one heading and in position within a 50-foot radius.

Bottom-Rest Anchorage Systems. Bottom-rest systems are negatively buoyant structures that rest on the ocean floor. Offshore oil well rigs and man-made islands are typical of structures of this type. At present, most of these installations are in water depths of approximately 200 feet. It is unrealistic to suppose that a bottom-rest structure could be employed for this project.

Dynamic Positioning

Dynamic positioning is an automatic method for positioning a floating vessel without the use of anchors and anchor lines. Dynamic positioning utilizes on-board power units which maintain the vessel in a fixed location against wind, wave, and current forces.

Dynamic positioning has proven to be a fairly successful technique for maintaining position. Operators of vessels using the method claim it is relatively easy to maintain position within 5% of the water depth; percentages of 1 or 2% are not uncommon. More sophisticated systems controlled by computers are fully automated, providing almost instantaneous response to the constantly changing sea surface.²⁶

There are three types of position sensing systems used for dynamic positioning: (1) taut wire, (2) sonar, and (3) radar. The taut wire system has been successful in water up to 2,000 feet deep. It consists of a heavy sinker placed on the ocean floor which is connected to the vessel by a wire line. Any drift in the ship will change the orientation of the wire and this change is measured by a sensing device which, in turn, feeds a signal to the control system which executes the steps necessary to correct for the drift. This system is the quickest, easiest, and most practical to use.²⁷

Radar and sonar sensing devices measure the changes in the relationships between the surface vessel and fixed points. The latter can be points on a nearby land mass, buoys, or points on the ocean floor. Radar apparently has an advantage over sonar, primarily because sonar sensing devices usually require submerged buoys for satisfactory operation.

Probably the most successful and sophisticated dynamic positioning system is that on the *GLOMAR CHALLENGER*, a drilling vessel recently commissioned by its owner, the Global Marine Corporation. On its maiden voyage, the unanchored ship was held in position by its main propellers and four side thrusters, with great precision. During one operation, the ship was drilling in 17,600 feet of water but did not drift more than 125 feet from its set point, even though there were winds of up to 30 knots. It is claimed that the ship can maintain position in over 2,000 fathoms in a sea state 6 and 40 knot winds.⁶

The system on the *CHALLENGER* is relatively simple. The lateral distance and direction of the ship from either of two reference sonar beacons on the ocean floor are determined by use of a digital computer. The system is automatic and requires little power. Apparently the reference beacons are expendable; they have a life of about 10 days.⁶

The success of the *GLOMAR CHALLENGER's* dynamic positioning system serves as strong testimony to the desirability of having the same type of system on the heavy-lift vessel. Dynamic positioning systems are easier to use, faster, and require none of the auxiliary vessels necessary for conventional anchoring techniques. Moreover, conventional anchoring techniques are depth limited, thereby seriously restricting the chances of extending the depths to which the loads can be lowered and positioned.

POSITION LOCATION²⁸

A problem related to maintaining position is that of positioning the vessel at the proper location (as opposed to simply holding position). It appears that the accuracy of the positioning operation is inversely related to the vessel's distance from land. For example, visual fixes on a land-based object 5 miles away, possibly by the use of a sextant, will permit positioning to within ± 5 to 15 feet. For distances from 5 to 300 nautical miles from land, a surface craft can be positioned to within ± 30 to 50 feet; however, accuracies in this range are possible only with sophisticated receivers on board the vessel and elaborate shore-based transmitters. In areas more than 300 miles from land, it appears that accuracies can vary from 1 to 5 nautical miles; while this is accurate for navigational purposes, it is unacceptable for underwater construction.

At first glance it would appear that the limitations of present positioning technology would seriously inhibit underwater placement and recovery. However, this is not as severe a limitation as one would suppose; Table A-2 illustrates why this is true.

Table A-2. Average Distances From Land to Selected Depths

(Source: NCEL TR-597: Deep ocean power systems, by E. Giorgi. Sept. 1968)

Location	Average Number of Miles to Reach a Depth of –		
	600 ft	2,000 ft	6,000 ft
East Coast	70	150	175
West Coast	21	28	32

It would be reasonable to assume, therefore, that a construction vessel would very seldom be further than 200 miles from land during a typical operation. Consequently, it can be assumed that there will be little difficulty in positioning a vessel within 50 feet of the chosen location.

For operation on seas from 5 to 300 nautical miles from land, there are three electromagnetic positioning systems which possess the best combinations of range, cost, and accuracy of operation:

1. **British Hyperbolic Navigation System.**²⁹ The British Hyperbolic Navigation System is built by Decca and has a range of 425 nautical miles. The accuracy is within 25 to 250 feet. High frequency signals from land-based transmitters are used in the system. Only one vessel can use the system at any one time, although a time sharing scheme can be implemented to permit more than one ship to receive signals.
2. **Raydist System.**²⁹ The Raydist System has an operating range of about 200 miles and an accuracy of 12 to 100 feet. The range is reduced to approximately 100 miles at night or in bad weather. Two land-based transmitters are used in this system. There are some operational difficulties, if, for any reason, power is lost at either of the transmitters.
3. **LORAC B.**²⁹ LORAC B has an operating range of 300 miles and an accuracy of 15 to 400 feet. There are four transmitters in this system.

For any operation in excess of 300 nautical miles from land, the best that can be hoped for is an accuracy of $\pm 1/2$ nautical mile.

It has been stated that positioning to within ± 30 to 40 feet would be optimal for deep ocean construction operations (Reference 28, p. 2.6). If this range is assumed to be acceptable, then it is safe to conclude that positioning will not be a serious problem for any surface supported lift system operating in a depth range of 0 to 6,000 feet. This assumption appears even more reasonable when it is realized that navigational satellites are presently in orbit which permit position determination of nearly the above tolerance regardless of the distance from land. In short, practically any required accuracy for positioning is either within or nearly within the state-of-the-art.

CONCLUSIONS

The positioning of a surface vessel should present no problems at any location off the continental United States. Accuracy of ± 30 feet appears acceptable for work under water and, in addition, is within the state-of-the-art.

For holding position, a dynamic positioning system is the most desirable. Positions can be held to within 2% of the operating depth with units currently in use.

Dynamic positioning systems are superior to conventional moorings from both operational and economic standpoints (at least for heavy-lift operations). Vessels of 5,000 to 10,000 tons displacement have been moored in deep water, but the cost has been excessive; for a mooring in 600 feet of water, the total cost may approach \$500,000 for anchors, chains, winches, and auxiliary equipment (Reference 26, p. 5.5). Unless a mooring system is to be used for a long time, it is safe to state that a dynamic positioning system is superior for operations in water depths in excess of 300 feet.

Appendix B

PIPE STRINGS

STEEL PIPE

High-grade steel is recommended for manufacturing pipe used to support heavy loads. Steels of minimum yield strengths in the range of 110,000 to 150,000 psi are considered the most suitable for the purposes of this project. Table 3 of this report summarizes the important properties of two types of steel pipe which satisfy these requirements.

Pipes manufactured from P-110 or V-150 steels have been made in diameters of up to at least 10-3/4 inches. Table 4 of the report presents some pertinent design parameters for a suitable range of pipe diameters.

PIPE COUPLINGS

The oil industry has developed couplings made of material which possesses the same ultimate strength as the pipe itself. There has, in addition, been extensive experience in designing pipe strings which are subjected to the same type of loading and operational procedures encountered in deep-sea heavy lift. Since there will be much making and breaking of the pipe string, a special coupling should be used to provide the longest possible life for the system. Table 5 of the report illustrates how the strengths of typical joints compare with the strength of the pipe. It can be seen that the joints are about 90% efficient in most cases.

Pipe couplings of up to 13-3/8-inch diameter have been successful in oil field operations, suggesting that it will be fairly easy to make couplings suitable for the needs of this project. Two basic pipe joint designs have been extensively used in the oil industry (Figure B-1): shrink grip and flash-weld. For a shrink-grip joint, the end of the pipe is threaded and a heated tool joint is threaded onto the end of the drill pipe. For a flash-weld joint, a special tool joint thread is fabricated and the connection is welded onto the pipe. For reasons not stated, the project engineers for the *FORDS* chose the shrink-grip method of coupling. It would appear that this approach is indeed the best of the two. Since the pipe is made of high-grade steel and is relatively large, any amount of welding would contribute to increasing costs and inspection difficulties and should, therefore, be avoided.

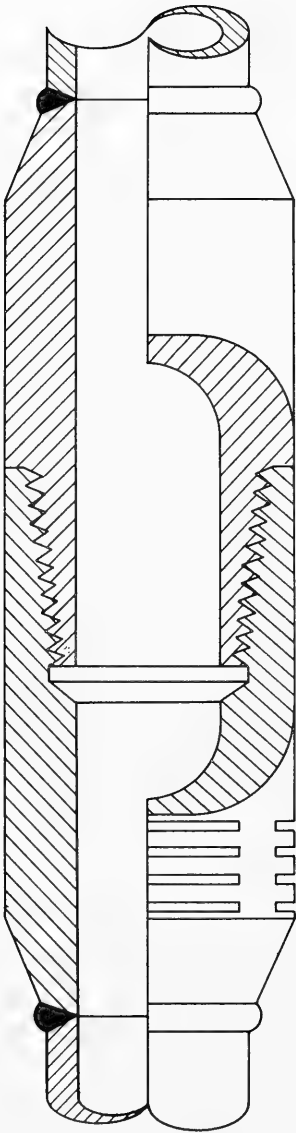

(a) Flash weld.

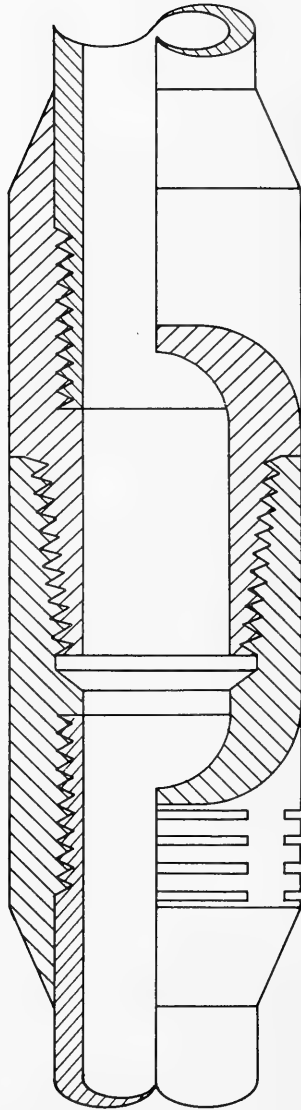

(b) Shrink grip.

Figure B-1. Pipe couplings.

There is some question whether the standard oil field drill pipe coupling will perform successfully in a heavy-lift operation. Drill pipes are, of course, rotated during the drilling operation and this helps prevent the couplings from unscrewing. It is conceivable that some unexpected vibrations in the drill string would tend to loosen the connections if a load were simply hung on the pipe. While this has not been given any thoughtful attention, it appears to be at worst a minor problem which could be solved by incorporating a mechanical locking device into the coupling.

PIPE STRING DESIGN

Assuming a safety factor of two and limiting attention to the severest case of a 600-ton load at 6,000 feet, it can be seen that of the different pipes given in Table 4, only the last three of V-150 grade steel will meet the requirements. These are the pipes of 10-3/4-inch OD weighing 71.1, 76.0, or 81.0 pounds per foot. The 10-3/4-inch OD pipe weighing 65.7 pounds per foot almost meets the design criteria, having a safety factor of 1.93. The 9-5/8-inch OD pipe weighing 61.1 pounds per foot has a safety factor of 1.81. The safety factors are presented in Table B-1.

Table B-1. Safety Factors for Pipe

Grade	OD (in.)	Weight (lb/ft in air)	Safety Factor for 600 Tons at 6,000 Feet
P-110	9-5/8	53.5	1.22
	10-3/4	65.7	1.47
	10-3/4	71.1	1.55
	10-3/4	76.0	1.62
	10-3/4	81.0	1.72
V-150	9-5/8	53.5	1.64
	9-5/8	58.4	1.75
	9-5/8	61.1	1.81
	10-3/4	65.7	1.93
	10-3/4	71.1	2.05
	10-3/4	76.0	2.17
	10-3/4	81.0	2.17

It is obvious that at lesser depths and/or lesser loads the safety factors would increase. Since it is highly conjectural how many lifts of 600 tons at 6,000 feet will be made, the only safe thing to do is give the worst case extra consideration. Therefore, assuming that a large fraction of the lifts will put the system to its maximum and, in addition, assuming that the highest factor of safety is the most desirable, the 10-3/4-inch OD pipe weighing 81 pounds per foot will be given a more detailed investigation.

Dynamic Loads

The preceding calculations for the factor of safety were based on conditions of static loading. For sea-going lift systems, the dynamic loads are extremely important and static conditions do not form a realistic basis for design. Because of this, the anticipated conditions of dynamic loading should be given.

There are two types of dynamic loading which are important in the analysis of this system: (1) loads incurred during a sudden stop and (2) loads imposed on the pipe due to ship motions.

Stresses Due to a Sudden Stop. Computing the stresses in the pipe due to a sudden stop requires that the force-time loading be either assumed or determined. It is extremely difficult, if not impossible, to determine the value of a load as a function of time. Because of this problem, it will be assumed that the load is applied suddenly over a limited duration and is constant (i.e., a rectangular pulse load). For a given time period, the force can be determined from impulse-momentum considerations. By use of the dynamic load factor, it is possible to compute the total load due to a sudden stop. The results are plotted in Figure B-2.

It can be seen in Figure B-2 that a safety factor of two is possible for all sudden stops at any depth, if the load-pipe string combination is decelerated from 2 to 0 feet per second in 5 seconds. Even if the stopping time is of the order of 1 second, the assumed safe maximum is not exceeded except for depths over 5,000 feet. As a basis for comparison, the stresses due to an immediate stop (computed using strain energy) are plotted in Figures B-3 and B-4. It is apparent that in the latter situation, the pipe string could be subjected to extremely high stresses; however, immediate stops are impossible to achieve, and the curves for the stresses imposed on the pipe over short time intervals are more realistic.

It is apparent that stopping the pipe string could be a risky operation, if the initial velocity were too high. The stopping operation is delicate and careful control has to be exercised over the entire sequence. Nevertheless, if

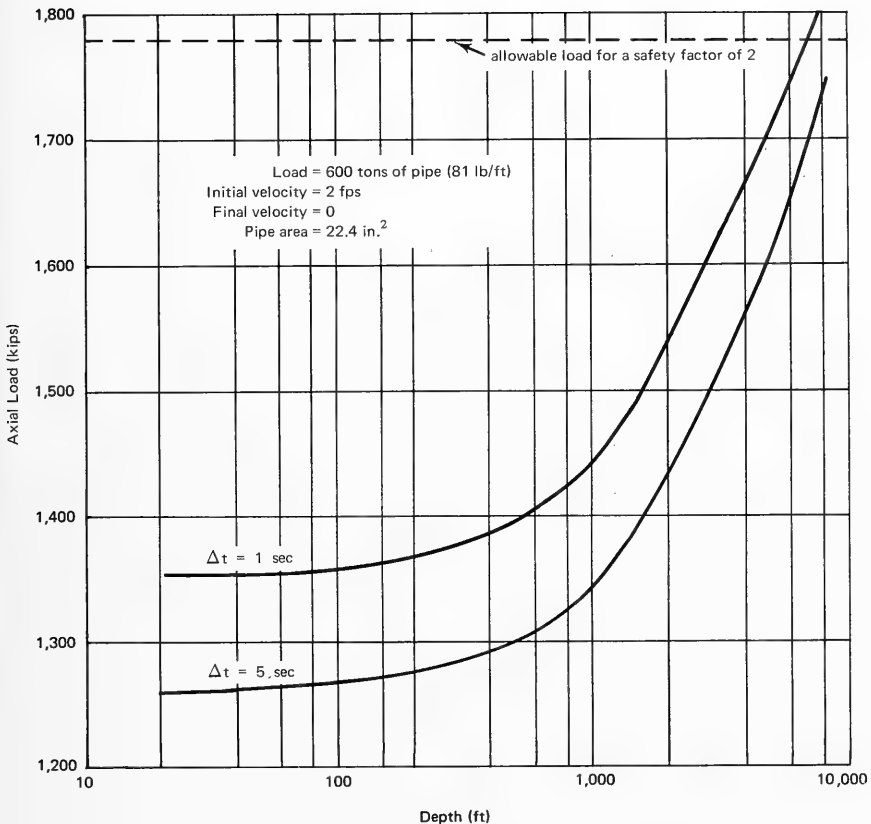

Figure B-2. Average total loads due to deceleration of pipe suspension medium.

it is assumed that such control is possible, (i.e., that adequate precautions are taken) then it is safe to assume that excessive stresses can be avoided during the stopping operation.

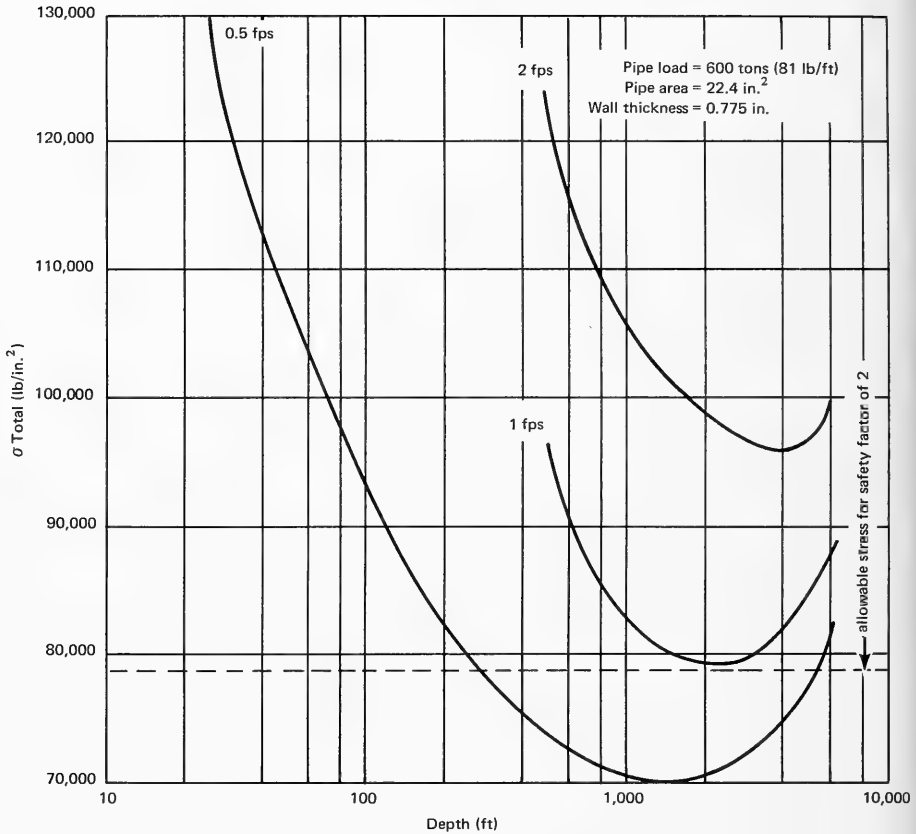

Figure B-3. Stresses due to an immediate stop of pipe suspension medium (600-ton load).

Stresses Due to Ship Motions. It is of great importance to investigate the pipe and load dynamics and the maximum dynamic stress in the pipe resulting in the motions of the suspension point. These factors can be utilized in a design procedure for calculating dynamic stresses for a given load at a given depth under varying conditions of sea surface oscillations.

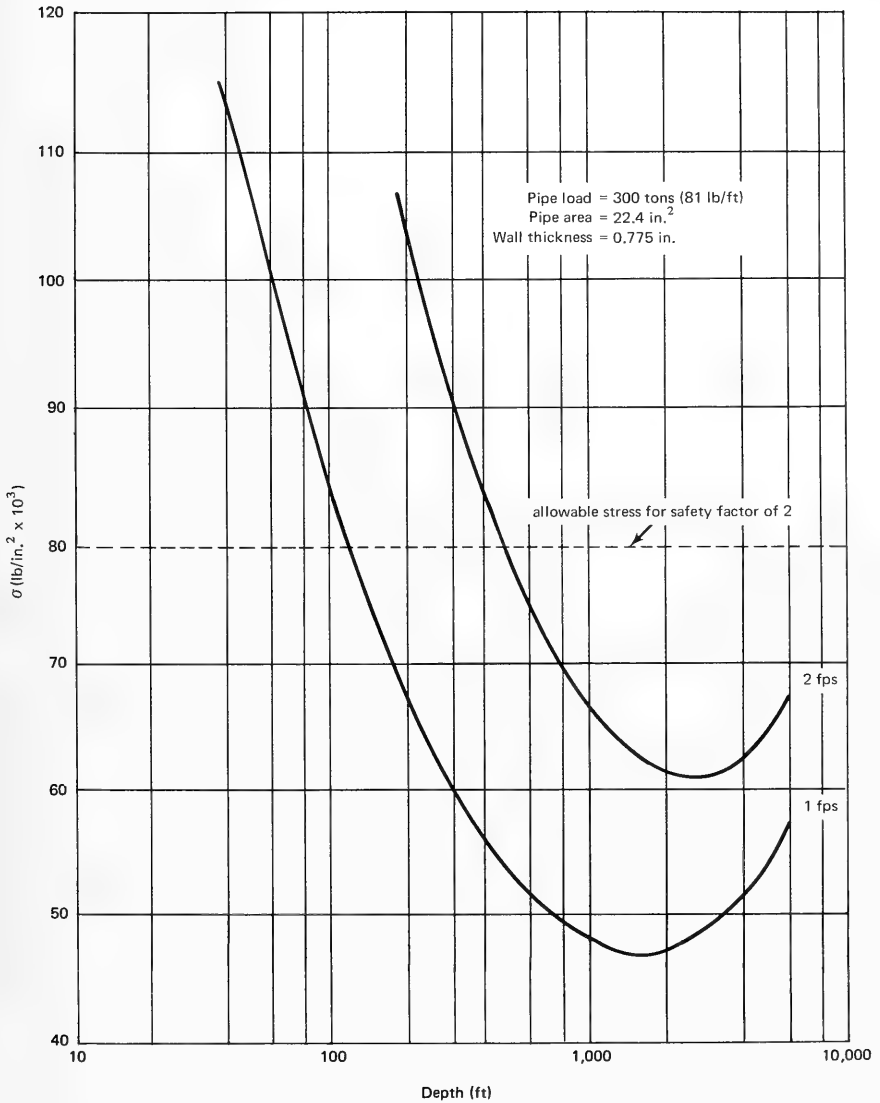

Figure B-4. Stresses due to an immediate stop of pipe suspension medium (300-ton load).

This problem is difficult to solve because of the nonlinear damping due to drag forces on the oscillating load and added mass. A simplified solution has been derived for cable systems.³⁰ It was modified for pipe string analysis and programmed for a computer. By using this program, the normalized amplitude of the maximum dynamic stress was computed. The results are plotted in Figure B-5. This figure presents the axial force induced in the pipe per foot of ship heave versus the period of the suspension point at the surface. For a given sea state and surface vessel, the period and heave can be calculated and the resulting dynamic force determined from the graphs.

Figure B-5 indicates that for periods up to 15 seconds significant loads can be imposed on the pipe for all depths and loads. Obviously, a floating platform or ship with a long period, say 60 seconds, would minimize the problem to the point of being insignificant. If a ship or platform is to be modified for heavy lift, its response in various sea states should be specified so that a range of safe operating environments can also be specified. In any case, it is apparent that by assuring the surface support vessel has a response of no less than, say 20 seconds in heave for the specified sea states of operation, and that the heave amplitude is 1 foot or less, the forces induced in the pipe string would be negligible. How difficult it would be to design a ship or platform satisfying these requirements is a point worthy of detailed investigation. This topic is discussed in greater detail near the end of this appendix.

Movement of the Load

The load will oscillate with the movement of the ship. The amount of oscillation is important during the final placement of the load. Excessive vertical oscillations will make accurate placement difficult and could conceivably subject the load to unacceptable shock loadings.

The same program used to compute the dynamic loads was used to calculate the movement of the object at the end of the pipe string. Figure B-6 shows the vertical movement of the load per foot of ship heave versus the period of the support point. For periods greater than about 12 seconds, the load moves with the ship; that is, the load moves the same amount as the ship heaves.

The effects of the ship heave on the load can be reduced to the point of being negligible. At points along the pipe string, bumper subs, which are simply large shock absorbers, can be installed to reduce the motion of the end of the pipe string and thereby reduce the strain on the pipe. There are various

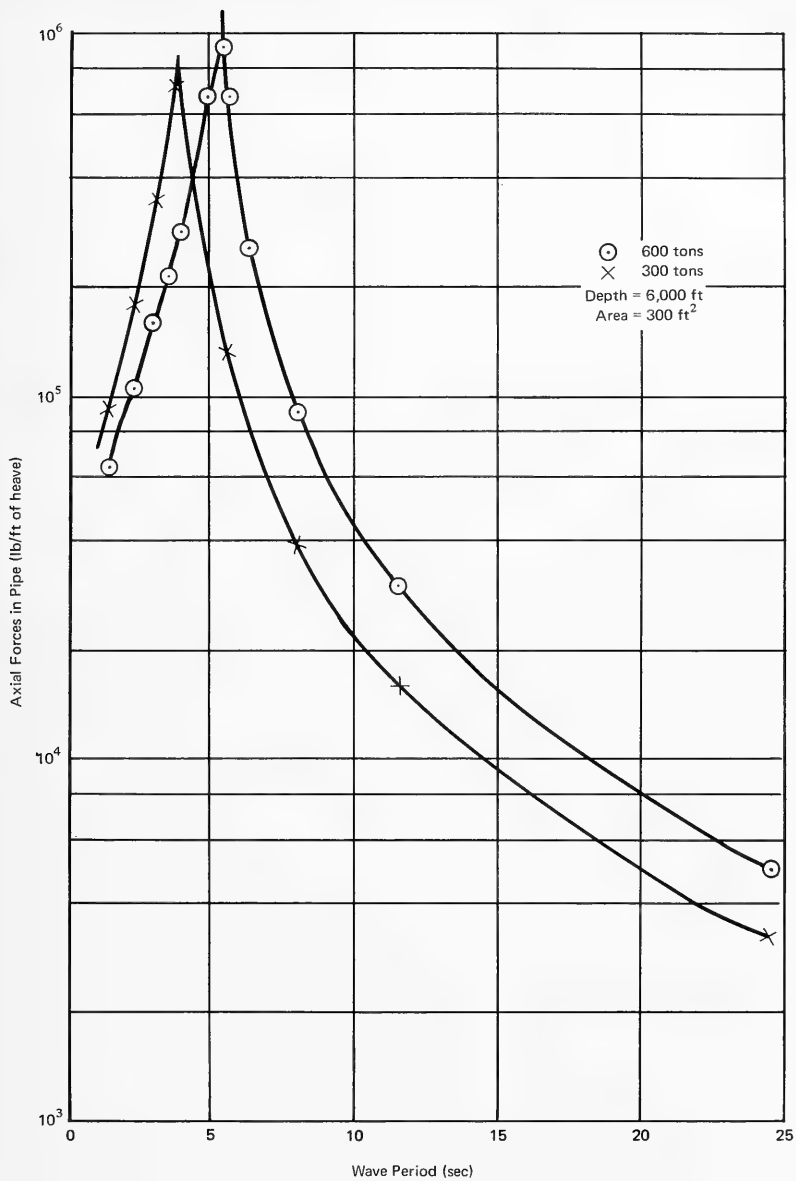

Figure B-5. Normalized amplitude of maximum dynamic force in pipe.

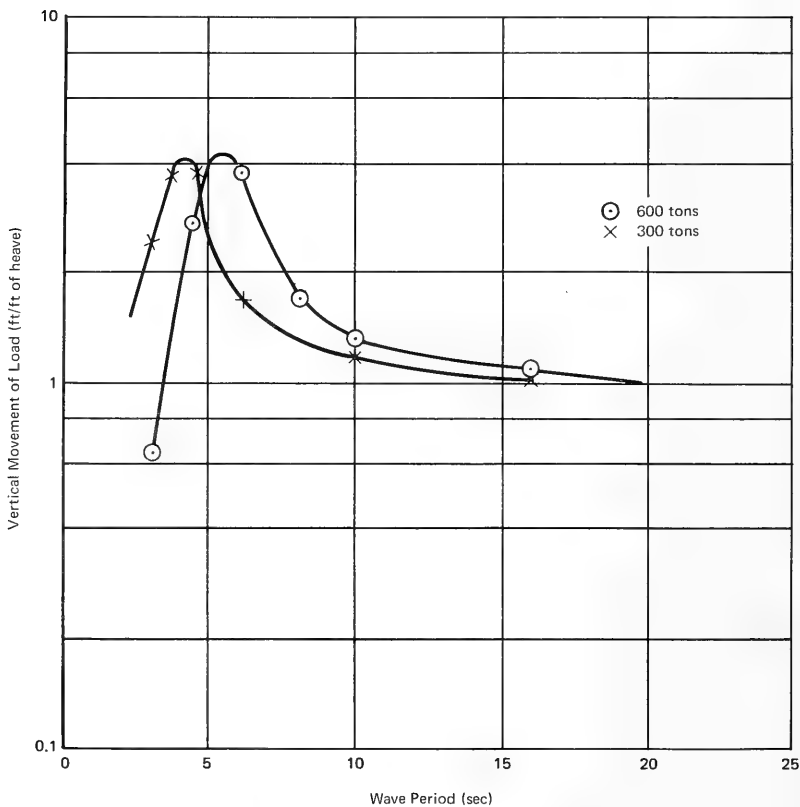

Figure B-6. Vertical movement of a load at 6,000 feet (cross-sectional area = 300 ft²).

types of bumper subs used in the oil industry, none of which are of size sufficient for the heavy-lift project. Although developmental items, it would appear to be fairly easy to fabricate bumper subs suitable for the heavy-lift project.

Conclusions

Assuming that the necessary precautions are taken in the design and operation of the pipe string assembly, it is safe to conclude that by using V-150 pipe, 10-3/4-inches in diameter, a 600-ton load could be lowered to 7,500 feet with a safety factor of two against failure. The most critical factor is the dynamic loading which could very easily overstress the pipe at the suspension point, if the support craft were heaving too much or if the load were stopped too suddenly. However, the latter are problems which are not unique to this project and serve to emphasize the importance of accurately stating the limitations of a system and operating within prescribed limits.

PIPE HANDLING EQUIPMENT³¹

The equipment necessary to assemble and lower a pipe string for a heavy-lift operation would be very similar to the standard equipment found at any oil well. The major components are: (1) derrick, (2) crown block, (3) traveling and hook block, (4) swivel, (5) pipe elevators, (6) tongs, (7) links, (8) slips, (9) guidelines, (10) leads, (11) draw works and power source, and (12) coupling devices.

Recently there have been some important improvements in pipe handling systems. *Discoverer II*, an offshore drilling vessel, has been outfitted with a hydraulic system which enables only three men to make and break drill pipe with the help of powered slips and tongs. The system is semi-automatic and utilizes equipment which, at the time it was constructed, was either available or required very little development. Other systems have been designed to make and break drill pipe which is in motion. The pipe handling system for MOHOLE was to be completely automated.

Derricks

The American Petroleum Institute has a set of standard specifications which serves as a guideline for the design of derricks of various sizes and load-handling capacities. Specifications for some of the largest "standard" derricks are given in Table B-2.

A typical offshore derrick is approximately 150 feet tall and has a load capacity of 500 tons. One of the largest derricks planned was that for MOHOLE: it was to be 196 feet high and hoist a 500-ton load with a safety factor of 1.67 (the static rating of the derrick was 1,000 tons).

Table B-2. Characteristics of Typical Derricks

Manufacturer	Height (ft)	Weight (tons)	Gross Nominal Capacity (tons)
Continental Emsco	142	52.9	526.5
IDECO, Presser Industries	143	45.7	407.5
Lee C. More Corp.	189	61.8	696.0

For the project under consideration, it is estimated that the derrick should be able to hoist 800 tons with a safety factor of two. This requirement is certainly within the state-of-the-art, but such a derrick would probably be one of special design.

Sheaves and Hoisting Equipment

Crown Blocks. The crown block provides a means of transferring the load to the derrick while, at the same time, providing mechanical advantage. Crown blocks usually consist of six or seven sheaves grooved to accommodate the wire cable. Specifications for some of the largest crown blocks are presented in Table B-3.

Table B-3. Characteristics of Standard Crown Blocks

Manufacturer	Maximum Working Load (tons)	Length (ft)	Height (in.)	Width (in.)	Weight (tons)
ALCO	600	---	---	---	---
Continental-Emsco	600	---	---	---	---
IDECO	560	9	63	46	5.0 – 5.4
National Supply	583	9	---	49-1/2	7.0
Oilwell Supply	580	8	59	50	6.3
Regan Forge	600	---	---	---	7.5 – 8.0

Designing a crown block to safely hoist an 800-ton load does not appear to be difficult. It is safe to conclude that an acceptable crown block could be built; it would most likely be a larger version of present units.

Traveling Blocks. It is desirable to have a unitized traveling block, i.e., one where the hook is attached directly to the block. Such an arrangement decreases the length of the hoisting equipment and thereby increases the length of pipe which can be handled in one lift cycle. Unitized traveling blocks have limited capacities, however, so the block will undoubtedly have to be separate from the hook. Capacities of some of the larger block-hook combinations are presented in Table B-4.

Table B-4. Characteristics of Standard Traveling Blocks

Manufacturer	Capacity (tons)	Weight (tons)
Continental Emsco with Byron Jackson "5,000" Dynaplex hook	600	7.8
Gardner Denver with Byron Jackson "5,000" Dynaplex hook	550	9.0
McKissack with Byron Jackson "5,500" Dynaplex hook	500	8.0
National Supply	500	11.2
Regan Forge with Byron Jackson "5,500" Dynaplex hook	500	5.8 – 11.0

It can be seen that currently available traveling blocks do not have large enough capacities for the purposes of this project. Again, however, it appears logical to assume that a traveling block of the desired capacity could be designed and built by simply increasing the size of the largest units presently available.

Draw Works and Winches. The draw works and hoisting drum are typically rated on the basis of horsepower. A unit of 2,500 horsepower is considered large, but for the MOHOLE project a unit of 4,000 horsepower had been designed. A typical unit can hoist 500 tons at a rate of 0.6 feet per second using a 6-sheave block.

Winch drums are available in varying sizes. The largest drum, 15 feet in diameter, is used in the mining industry. For the pipe handling unit under consideration, it does not appear that a unit this large will be needed. In all probability, the winch unit can be a standard off-the-shelf item.

Conclusions

There is substantial evidence to indicate that a considerable portion of the hoisting equipment currently in use is readily adaptable for lifting loads of up to 500 tons in offshore construction. Standard derricks, crown blocks, traveling blocks, tool joints, and draw works will successfully lift a 500-ton load. Limited extensions of current technology will provide items of equipment which will permit hoisting loads of up to 600 tons, the arbitrary maximum for this project.

COSTS OF PIPE HANDLING EQUIPMENT³²

The cost estimates are based on the V-150 pipe, 10-3/4 inches in diameter. The following is a rough estimate of the total cost (1964), exclusive of the derrick:

6,000 ft of pipe at \$1,630/100 feet	\$ 98,000
Tool joints	1,250
Double-drum hoisting unit with motor and brake	258,000
Crown block, traveling blocks, rope, guides, and hoist	177,000
Makeup and breakout machine	95,000
Pipe racking and storage units	194,000
26 guide sheaves	167,000
Installation	159,000
	<u>\$1,149,250</u>
	<u>300,000</u>
Estimated cost of derrick	
Total estimated cost	\$1,449,250

OTHER METALLIC PIPES

Other than aluminum, there are no nonferrous pipes being made in sufficient size and quantity for the heavy-lift operation. In fact, no aluminum pipe is made which will satisfy all the requirements for the project in question. Aluminum pipe currently manufactured is not large enough nor strong enough to safely support its own weight and a 600-ton load at 6,000 feet. Table B-5 presents the specifications for the larger aluminum drill pipes currently available.

Table B-5. Specifications for Aluminum Pipe

OD (in.)	Wall Thickness (in.)	Typical Breaking Load (lb)	Weight With Tool Joints in Air (lb/ft)
3-1/2	0.512	380,000	7.87
4	0.460	399,000	9.68
4-1/2	0.500	475,000	10.75
5	0.525	562,000	13.75
5-1/2	0.500	601,000	14.45

ADDITIONAL DESIGN CONSIDERATIONS

Bending Stresses

Currents acting normal to the pipe string can induce bending stresses at the support point. The worst possible case is that in which the pipe is assumed to have one fixed end. While this is not entirely possible for the drill string, the assumption will give conservative answers for the design analysis. The maximum moment, M_{\max} , due to bending is given by³³

$$M_{\max} = -W \sqrt{\frac{EI}{P}} \left[\ell \tanh \frac{\ell}{\sqrt{\frac{EI}{P}}} - \sqrt{\frac{EI}{P}} \left(1 - \operatorname{sech} \frac{\ell}{\sqrt{\frac{EI}{P}}} \right) \right]$$

- where W = uniform horizontal load (lb/ft)
 P = axial tensile load (lb)
 l = length of pipe (ft)
 E = Young's modulus (lb/ft²)
 I = moment of inertia (ft⁴)

Assuming the pipe is 10-3/4 inches in diameter and a horizontal current velocity of 1/2 knot, it is possible to use the above equation to compute the bending stress. The results are plotted in Figure B-7.

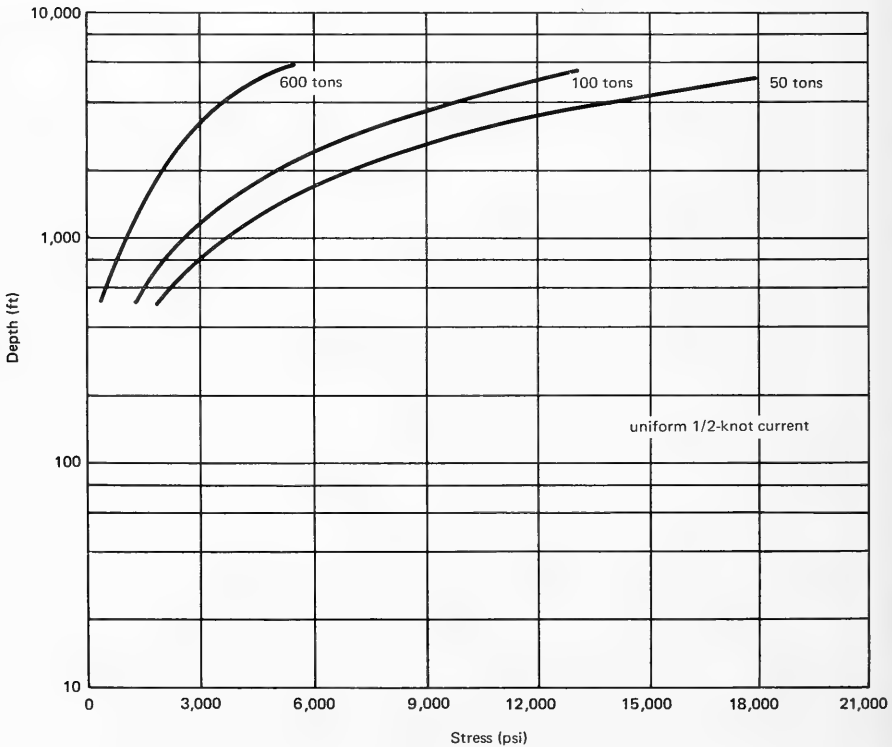

Figure B-7. Pipe stress due to bending.

A typical approximation in the industry is to assume that a 1/2-knot current is acting on the pipe string along its entire length. Since this assumption has proven to be a good design criterion, it appears that a stress of around 6,000 psi in bending can be considered the maximum for a horizontal current loading on a 600-ton load. For lighter loads, however, some fairly high stresses are possible. While these are significant, they will not stress the pipe beyond 70% of the yield stress (the industry's accepted maximum for the total combined stress).

Displacement of the Load

Horizontal currents will tend to displace the load. The maximum deflection, y_{\max} , is calculated by using the equation³³

$$y_{\max} = \frac{-Wj}{P} \left[j \left(1 - \frac{1}{2} U^2 - \sec hU \right) - \ell (\tan hU - U) \right]$$

where $U = \frac{\ell}{j}$

$$j = \sqrt{\frac{EI}{P}}$$

The deflections were calculated for various loads. The results are plotted in Figure B-8.

It can be seen that the load could be displaced considerable distances under the influence of a 1/2-knot current. The lighter loads will be displaced further than the heavier loads, in some cases over 200 feet. The distances plotted in Figure B-8 are less than those which would probably be encountered in an actual operation since the drag on the load was not taken into account.

It appears that there is no practical way to avoid the problem of displacement other than having some kind of guy wire arrangement. The obvious solution is to have the surface support vessel upstream from the foundations, although it would appear that this would be a difficult operation to perform with an acceptable degree of accuracy.

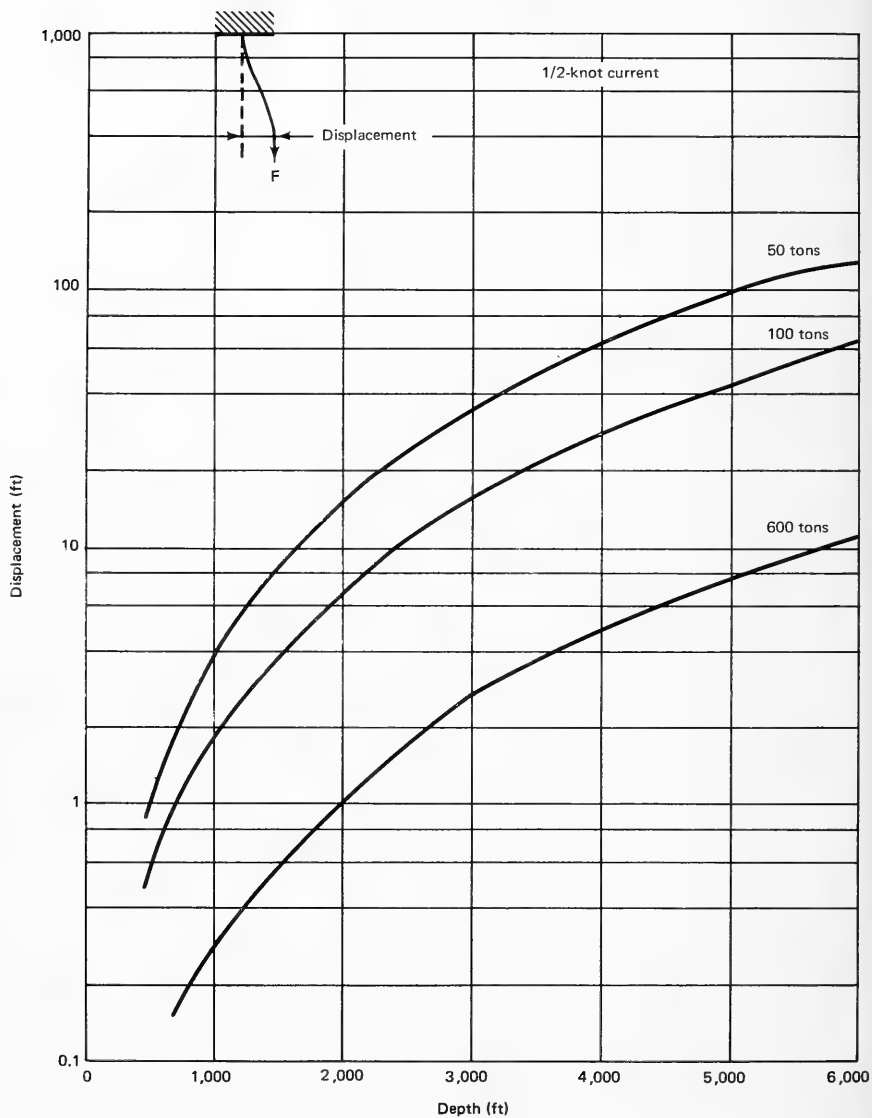

Figure B-8. Displacement of load due to horizontal currents.

Buoyancy

The pipe string itself could provide a considerable amount of buoyancy. All of the pipe sizes given in Table 4 have a collapse depth in excess of 6,000 feet with tensile loading, thereby making it unnecessary to flood the pipe to equalize the internal and ambient pressures. Figure B-9 illustrates how the buoyancy varies with depth.

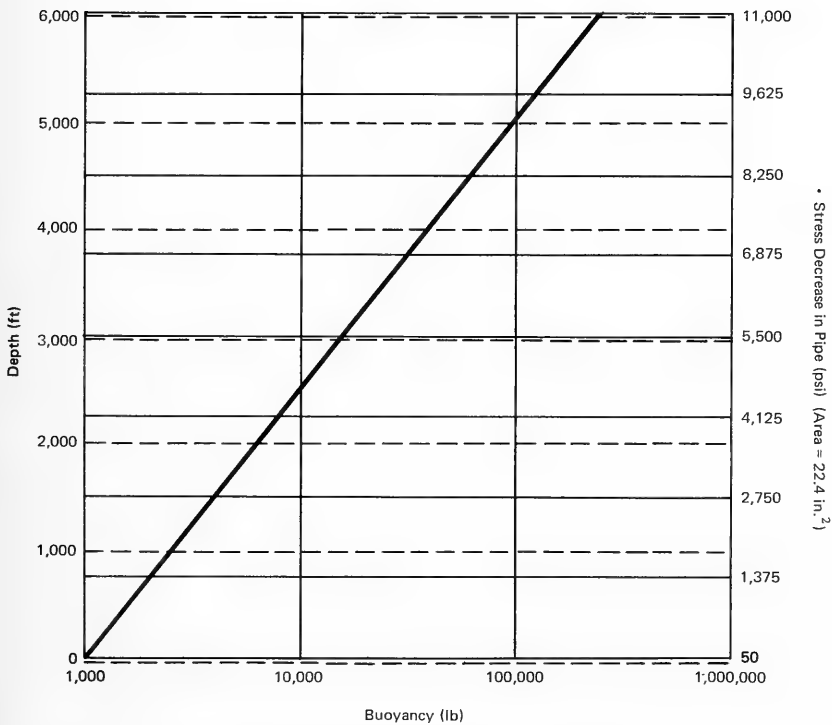

Figure B-9. Buoyancy of 10-3/4-inch diameter pipe.

It can be seen that the buoyant force can reduce the axial stress by about 10% of the stress due to the weight of the pipe string and a 600-ton load. This is of great advantage in reducing the total stresses and indicates that the pipe string should not be flooded.

Tapering

The desirability of tapering the pipe string is obvious. Sections of the pipe closer to the load can be lighter than those closer to the ship. A pipe string designed to take advantage of this principle is illustrated in Figure B-10.

There are probably other designs which would be more optimal than the one illustrated in Figure B-10; nevertheless, it is difficult to conceive of a design which would result in significant increases in the safety factors. For the design illustrated, the safety factors are not appreciably different than if the pipe weighed a uniform 81 lb/ft throughout its entire length. This is due, primarily, to the fact that the load (600 tons) is very nearly half the allowable load for the pipes. However, the pipe string presented in Figure B-10 will hold a 357-ton load at 6,000 feet with a safety factor of three.

There is no reason to make a major effort in trying to achieve optimal weight economy in the pipe string. The large load capacities of present pipe handling equipment makes this unnecessary, not to mention the fact that drill pipe of any kind and size represents only a small fraction of the total ship capacity. In addition, steels of high strength-to-weight ratios require that strict attention be paid to minimum wall thicknesses, since handling can cause impact damage resulting in cracks which lead to fatigue failure.

Fatigue

While important, yield strength alone cannot be used as a basis for design. It is not sufficient to know that sporadic accelerations of the load will not impart forces greater than the yield strength. The usable life of the pipe must be determined from the cumulative damage resulting from cyclic loading.

In the design of aircraft, the useful life of a structural member is calculated using the equation

$$\sum \frac{n_i}{N_i} = 0.3$$

where n_i = number of cycles at the stress level

N_i = life at the stress level

By fixing the allowable sum of the cycle ratios, as above, the duration of pipe usage may be determined. The fatigue properties of the materials must be known in some detail to establish the values of N_i . Experiments which will yield such data are common. Careful record keeping during the life of the system will serve as an aid to the operators in determining the probability of weaknesses in the pipe or joints. Another possibility is the system used by the crew of the *Glomar Challenger*. Each time the ship puts into port the pipe is inspected with an internal sonde and any pipe and/or joints with suspected defects are given a more thorough inspection before being put back into use.

Life of the Pipe. It is possible to analyze the life of a member if nothing is known about the material except the ultimate tensile stress. The results will, of course, be approximate, but they can be used as a safe basis for design.

It will be assumed that the stress variation, $\pm\Delta\sigma$, due to the dynamic load is 20% of the static stress, σ_{av} . The part is to have an infinite life. The material is V-150 having an ultimate tensile stress of 150,000 psi. It is desired to find the allowable mean stress, σ_{av} , due to static loading.

If no fatigue test data on the endurance limit are available, it can be assumed that one-third the ultimate stress is the endurance limit. In this case 50,000 psi is the endurance limit in completely reversed loading.

On the basis of the above, $\Delta\sigma = 0.20 \sigma_{av}$. From the assumption on the endurance limit

$$\Delta\sigma_o = \frac{\sigma_{ult}}{3}$$

Therefore
$$\frac{\Delta\sigma}{\Delta\sigma_o} = 0.60 \frac{\sigma_{av}}{\sigma_{ult}}$$

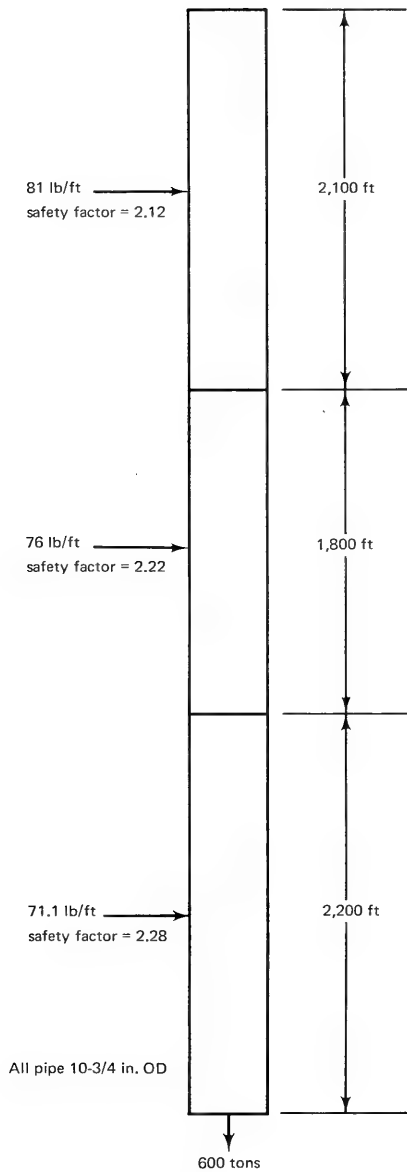

Figure B-10. Pipe string design.

Assuming a straight line interaction relationship

$$\frac{\Delta\sigma}{\Delta\sigma_0} + \frac{\sigma_{av}}{\sigma_{ult}} = 1.0$$

$$1.6 \frac{\sigma_{av}}{\sigma_{ult}} = 1$$

$$\frac{\sigma_{av}}{\sigma_{ult}} = 0.625$$

$$\sigma_{av} = 0.625 \sigma_{ult} = 0.625 (150,000)$$

$$\sigma_{av} = 94,000 \text{ psi}$$

This value of σ_{av} will have to be reduced by the appropriate safety factor. In the most severe case, 600 tons at 6,000 feet, $\sigma_{av} = 75,000$ psi. The factor of safety is therefore $124,000/75,000 = 1.25$; it increases, of course, as the depth and/or load decrease. In any case, it appears that the pipe is relatively safe from fatigue failure due to tensile loading only. As stated earlier, $\Delta\sigma$ is approximately 10% of the static stress in the severest sea states, so the above approximations are well on the safe side.

Additional Dynamic Forces

Angular ship motions about the horizontal plane create transverse and torsional vibrations in the pipe, at the ship. The roll of the ship is the principal cause of transverse excitation. This particular motion is important in determining the number of bending cycles imparted at the uppermost portions of the pipe string. However, only the first few sections of pipe will be affected by the slight amount of roll and the bending stresses will be small. For the purposes of this study they can be ignored.

Cyclic torsional stresses would not usually be encountered in a heavy-lift system employing pipe string. The pipe would not be rotated as would the drill pipe on a deep-sea rig. While this is advantageous in designing the system, it still has been found in drilling practice that torsion is not a major cause of drill string failure.

SHIP MOTIONS

Floating vessels oscillate in two modes: forced and free. The amplitude of forced oscillations is dependent upon the forces between the waves and the vessel and on the relationship between the natural frequency and wave frequency. The amplitude of the free oscillations is a function of the way in which the energy is dissipated as the vessel moves. Figure B-11 illustrates the relationship between the natural frequency of the ship and the frequency of the waves. The curve is the same as any resonant curve for a simple oscillating system with damping. A ship usually operates in the area around resonance, so there is a good chance that heave can exceed wave height. The response of a vessel is not as simple as Figure B-11 illustrates, since the ship motions will be modified if the wavelength is equal to the length of the ship or considerably smaller.

Two ships whose characteristics have been determined by laboratory tests are discussed in following paragraphs. These ships are the *T-2* tanker and the *C1-M-AV1*. They represent two important classes of ships that will give a realistic range of response characteristics for an operation of the type under consideration. The *FORDS* platform is investigated in some detail also.

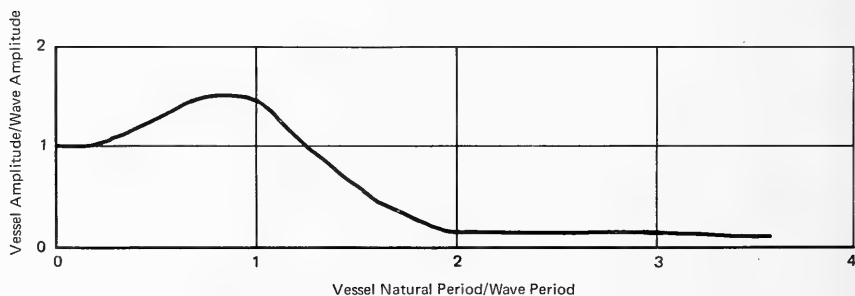

Figure B-11. Typical vessel response curve.

Response of a Converted T-2 Tanker³⁴

The T-2 tanker has been found to be one of the best of the currently available ships for conversion to special applications such as heavy lift. For example, Project ARTEMIS, which required lifts of approximately 190 tons to 1,200 feet, employed a converted T-2 tanker with a large free-flooding well near the center. The principal characteristics and dimensions of the enlarged T-2 tanker used in Project ARTEMIS are as follows:

Length	503 feet
Beam	68 feet
Mean draft	27 feet
Displacement	17,000 long tons
Natural pitching period	7.0 seconds
Natural heaving period	7.2 seconds
Natural rolling period	12.2 seconds

The T-2 tanker is a relatively large ship which has power sufficient to support a heavy-lift system. It is fairly stable and is large enough to provide ample room for both facilities and crew. However, most T-2 tankers are showing signs of age, thereby making it doubtful that one could be converted to heavy-lift operations without extensive modifications. Nevertheless, the amounts of heave, pitch, etc. of the T-2 in a fully developed sea are excellent inputs for computing the dynamic stresses imposed on lines suspended from ships of this size.

Of interest is a report entitled "Seaworthiness Tests on a Model of a T-2 Tanker With a Well Arrangement Near Amidships."³⁴ This report is concerned primarily with the effect of the well on the heave and pitch of the ship. The motions of the ship were observed in a fully developed sea state 5 with 21-knot winds. Table B-6 summarizes the average heave amplitudes for a T-2 tanker.

To get a better grasp on exactly how the ship heaves, the response amplitude operators for heave motion in long-crested seas is multiplied by the Neumann spectrum. The result is shown in Figure B-12. The figures in the graph compare favorably with those in Table B-6.

Assuming that the sea is in a steady-state condition, it is then possible to compute the axial force due to heave in the pipe string by multiplying the value of the heave spectrum by the force/heave diagram derived earlier. Figure B-13 illustrates the relationships between dynamic force and heave period for various depths for a T-2 tanker. There is little possibility of these values being exceeded. The graph indicates that the maximum dynamic stress is about 5% of the static stress.

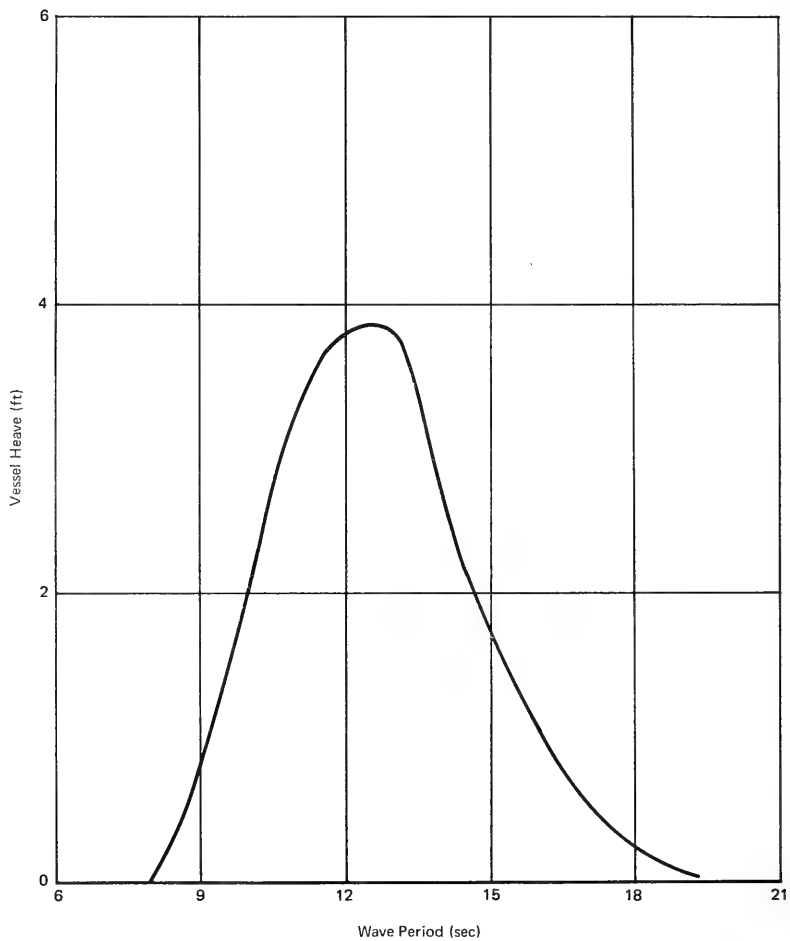

Figure B-12. Heave of a T-2 tanker in a fully developed sea with 20-knot wind.

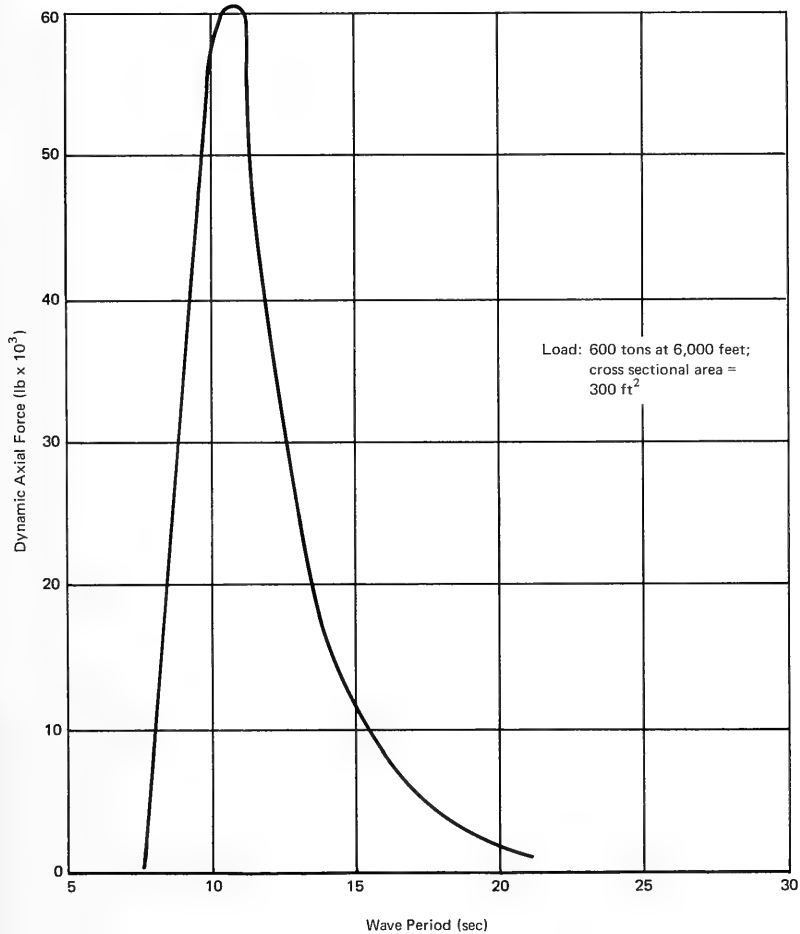

Figure B-13. Dynamic force in pipe string suspended from a T-2 tanker (fully developed sea with 20-knot wind).

Table B-6. Response Characteristics of a *T-2* Tanker¹

Ship Speed (knots)	1/3 Highest Amplitude		1/10 Highest Amplitude	
	Pitch (degrees)	Heave (ft)	Pitch (degrees)	Heave (ft)
0	0.78	0.77	0.97	0.98
5	0.92	—	1.17	—
10	1.11	—	1.42	—
15	1.10	1.06	1.40	1.35

¹ Reference 34, p. 5

A conclusion reached from the above is that a *T-2* tanker or a ship of similar size would safely support a pipe string—load combination in all but the severest sea states. There is some question whether the equipment necessary to handle and support the pipe string could be installed on the tanker. Up to the present, *T-2* tankers used for heavy-lift operations have used cable-winch systems to lower the load. It would appear at first glance that it would be no more difficult to install pipe handling equipment on the *T-2* than on the *Cuss I*. Therefore, a *T-2* tanker or comparable ship would be worthy of serious consideration in the heavy-lift project.

Response of the *C1-M-AV1*³⁵

The *C1-M-AV1* has been analyzed in some detail for use as a deep ocean drilling ship. This ship was at one time considered ideal for a test bed for the MOHOLE project. Its response would be very much the same as present drilling ships. The pertinent specifications are as follows:

Length	338 feet
Beam	50 feet
Full load displacement	7,400 tons

The wave amplitude spectrum describing a specific sea condition is needed to calculate the ship response spectra. Assuming a fully developed sea with a 20-knot wind, the following values can be determined:

Average wave height	5.0 feet
1/10 highest height	10.0 feet
1/1,000 highest height	15.0 feet

Calculation of the response motions of the ship in the above sea state can be complicated. However, by use of some simplifying assumptions (primarily eliminating nonlinearities), the amplitude response of the *C1-M-AV1* in head-on heave can be arrived at with a minimum of difficulty. The results are plotted in Figure B-14.

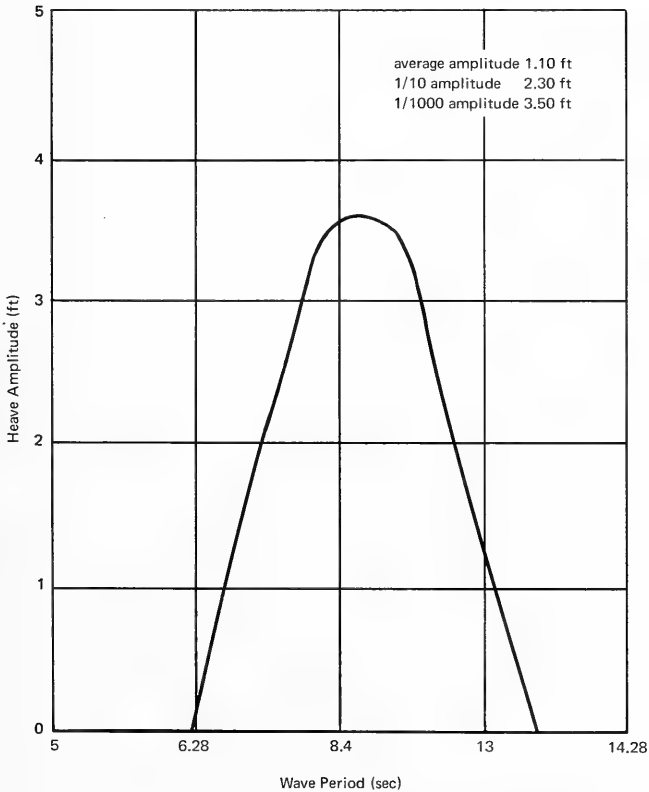

Figure B-14. Combined pitch and heave response of a *C1-M-AV1* in fully developed sea (20-knot wind).³⁵

It can be seen that the *C1-M-AV1* will not respond to waves of periods of about 6 seconds, while it will move with waves of periods greater than 14 seconds. The average amplitude for the ship is 1.1 feet in the wave. If it were in phase with an average wave, the total heave would be $5 + 1.1 = 6.1$ feet with respect to the ocean floor. Figure B-15 illustrates the relationship between dynamic axial force and the frequency of oscillation. The values are for average amplitudes and could increase significantly if conditions changed.

It appears that the ship used for heavy lift will need a longer period in heave than the *C1-M-AV1* or if that is found to be difficult to achieve, some type of heave compensating mechanism is needed to reduce the effects of vertical motion. The latter approach is being used on the *Alcoa Seaprobe*, where a heave compensating crown block will be installed. As far as is known, this is the first ship using such a device; much success is predicted by the designers.

Motion of *FORDS*³⁶

Probably the ultimate in stable platforms so far proposed is the Naval Research Laboratory's Floating Ocean Research and Development Station (*FORDS*). While the prototype was never constructed, models of the platform were tested in the David Taylor Model Basin. The results of the investigation illustrate the response characteristics of the platform in some detail.

Two important test conditions were studied in the experiments:

<u>Condition</u>	<u>Draft (ft)</u>	<u>Weight (long tons)</u>	<u>Natural Period in Heave (sec)</u>
1	30	13,510	5.3
2	265	19,220	123.3

The light draft motions (test condition no. 1) are comparable in magnitude to those of a ship of the same displacement.

Figure B-16 illustrates response of the platform in heave for regular waves of small amplitude. A summary of the irregular wave data is given in Table B-7.

Assuming a wave period of 9 seconds for both test conditions, the approximate dynamic axial forces are as shown in Table B-8.

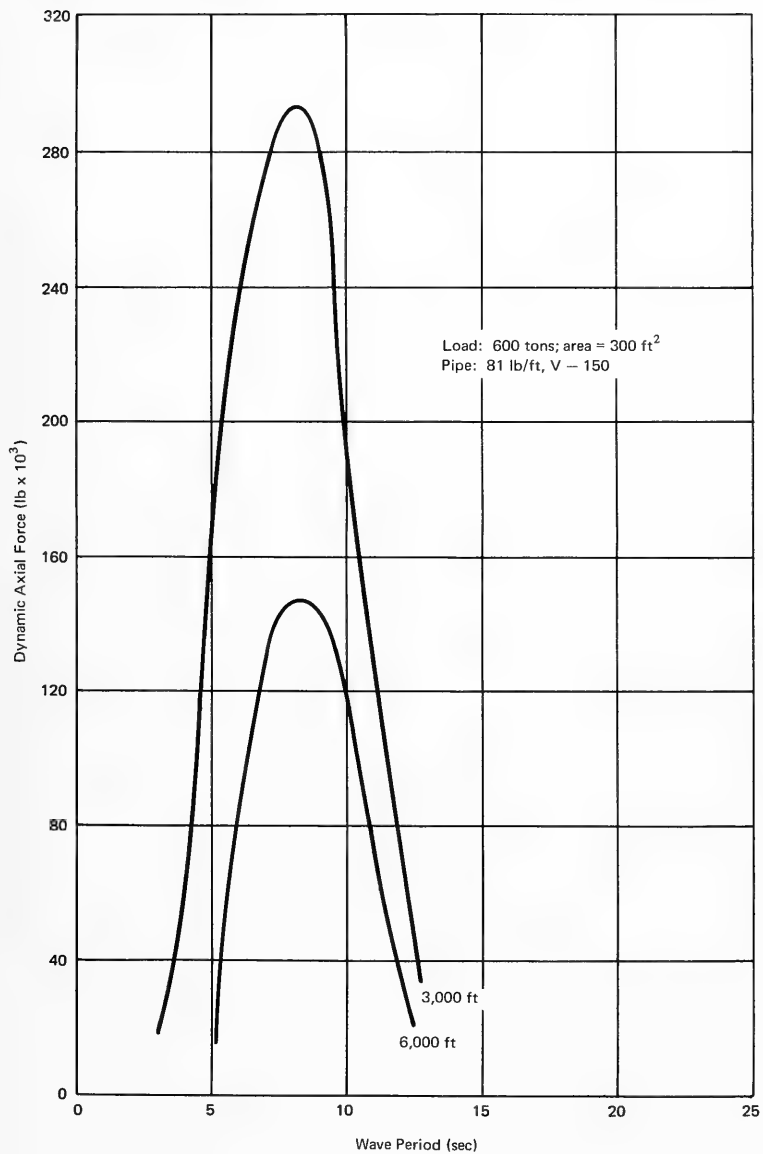

Figure B-15. Dynamic force in pipe string suspended from a *C1-M-AV1* (fully developed sea with 20-knot wind).

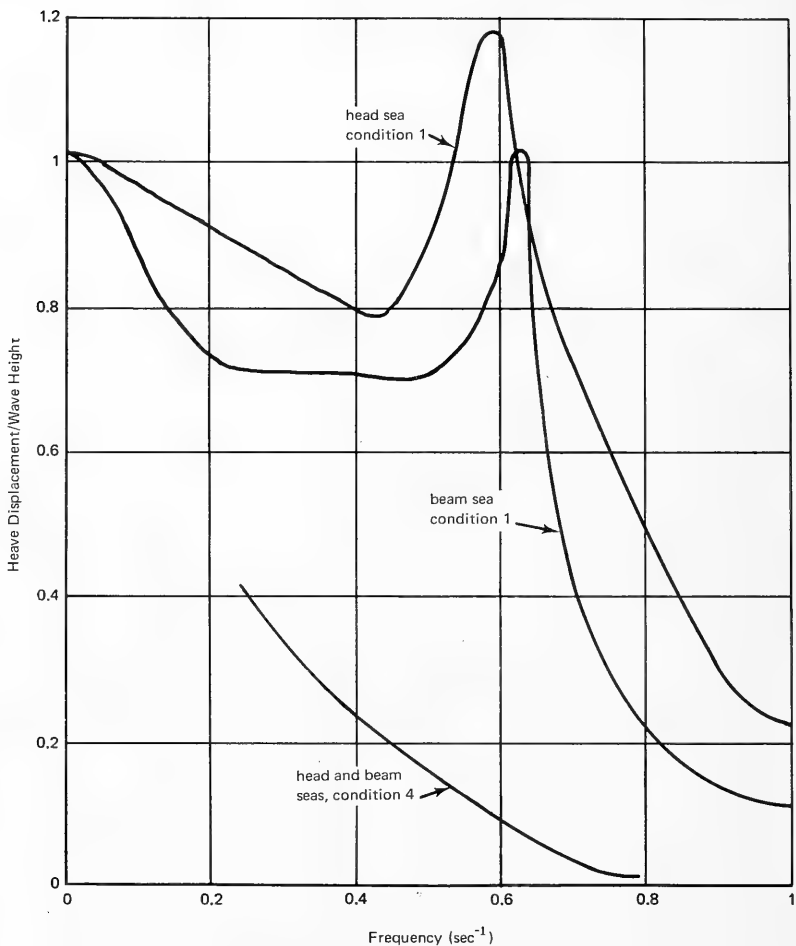

Figure B-16. Heave response of *FORDS* in regular waves of small amplitude.

The axial forces imparted in the string for test condition 1 are particularly significant; they are comparable to what can be expected in a ship of around 13,000 tons displacement. For a ship heading directly into a sea state 6, the dynamic forces are 17% of the static forces; for a sea state 4 the same heading will result in dynamic stress 10% of the static. The latter is more realistic.

Table B-7. Heave Response of *FORDS* Under Varying Draft Conditions

Condition	Sea State	Heading	Heave (ft)
1	4 ¹	head	2.50
		beam	4.09
1	6 ²	head	4.56
		beam	6.08
2	6	head	0.51
		beam	0.56
		oblique	0.35

¹Average wave height = 4.4 feet. Period of maximum energy is 9.1 seconds.

²Average wave height = 8.5 feet. Period of maximum energy is 9.4 seconds.

Table B-8. Dynamic Force in Pipe String Suspended from *FORDS*

(Load weighs 600 tons, has a cross-sectional area of 300 ft², and is suspended 3,000 feet below the surface vessel. Pipe weighs 81 lb/ft. (With respect to dynamic loading, this is the worst case.))

Condition	Sea State	Heading	Force (lb)
1	4	head	100,000
		beam	156,000
1	6	head	186,000
		beam	242,000
2	6	head	20,000
		beam	20,000
		oblique	14,000

It is obvious that the motions of the platform decrease significantly as the draft increases. In an oblique heading, the motions are generally less than a head or beam heading for the same sea state and draft. Based on intuition, it would seem likely that a platform or ship would heave less headed into the sea than having its full length exposed in a beam sea. The smaller motions of the platform in oblique seas are not as obvious, but important, since this does give more leeway in how the platform can be oriented. On the other hand, a ship will require a fairly accurate heading, especially in the more severe seas. This is important only if the direction of the predominant sea can change rapidly.

CONNECTING THE PIPE TO THE LOAD

The problem of disconnecting the pipe from the load after it has been placed can be solved by at least three techniques:

1. Use of a robot
2. A hydraulic actuated mechanism
3. A mechanical device

Examples of two of these approaches are illustrated in Figure B-17.

There are some important factors to consider in the design of the connector. Of primary concern are the difficulties of remote operation of mechanisms at a great distance. This is a problem when the load is to be disconnected from the pipe, but it is a special problem when the pipe must be reconnected to the load. The latter problem of location and reconnection can be solved in a number of ways; some of the more promising of these are:

1. Use of a manned submersible.
2. Use of underwater television, such as a *CURV*-like vehicle.
3. A permanent vertical cable, from the load to a submerged buoy, which could serve as a guideline for the connector.

It does not appear feasible to have a heavy-lift system which would have the capability of lifting all types of loads; it is not possible to have simple and dependable connectors that will accommodate all types of loads. Thus, the load will have to be designed with the lift system in mind; for example, for the pipe string system only one lifting point is allowable.

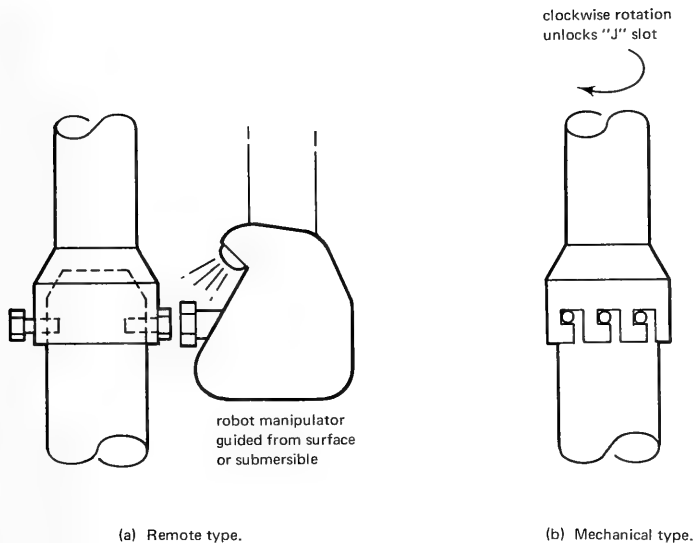

Figure B-17. Connector mechanisms.

For lifting debris from a wreckage, it does not appear possible to have a connector system that would satisfy all possible situations. There have been some designs for systems which would grasp an object (usually cylindrical) with mechanical fingers. *CURV*, the unmanned submersible, recovered the H-bomb with a mechanism of this type.

Most of the design and use of remote connector devices for underwater use are done in the oil industry. A review of the techniques and discussions with oil industry personnel indicate that a remote connector system will not present unsolvable problems although some development will be required.

CONCLUSIONS

It is important to note that no consideration has been given in the preceding analyses to damping. The added mass of the water column above the load and the water columns above the rubber pipe protectors will serve as buffers against undue stresses being imposed at the support point. The environment is one of random shock and vibrations, making dynamic stresses difficult to determine. However, the fact that there is damping would tend to decrease the dynamic loads at the points of maximum stress. The low frequency, high amplitude motions of the ship would be reduced to an acceptable maximum by a well-designed damping system.

To assure that the drill pipe on the *Glomar Challenger* would not resonate, ordinary rubber pipe protectors were installed every 5 feet along the pipe. It was predicted and later proven at sea that the protectors would sufficiently dampen any motion of the ship and thereby eliminate resonant buildup. A side benefit was that of eliminating the need for a tapered drill string. Similar approaches have been either suggested or attempted; of the latter, all have proven invaluable in avoiding resonance and increasing the safety factor.

Longitudinal oscillations are the most severe and, fortunately, the best known. These vibrations have been given a fair amount of attention in the preceding pages. It is safe to conclude that the proper drill string design with an efficient damping system, combined with a ship of suitable motion response characteristics, will successfully lower and lift heavy loads to depths of 6,000 feet. A ship the size of a *T-2* tanker with 10-3/4-inch OD pipe is particularly promising and could meet any reasonable design criteria. There is no question that a floating platform, such as *FORDS*, could handle loads of this type in all but extraordinary seas.

Appendix C

CONCEPTUAL DESIGNS FOR CANDIDATE NEAR BOTTOM TRANSPORT SYSTEMS

HEAVY-LIFT SUBMERSIBLE

Three configurations are investigated: (1) deballasting using high-pressure helium, (2) deballasting using a hydrazine gas generator, and (3) a vehicle employing buoyant ring-stiffened cylindrical lift tanks.

High-Pressure Helium System

1. **Ballast Tanks.** Two cylindrical tanks with hemispherical end caps would be used. Each tank will provide a nominal buoyant lift of 10 tons (the weight of helium in the tanks after deballasting will be neglected).

$$\text{displ} = (\text{vol of tank}) \gamma = \left[\frac{(2)(4)(\pi)(r^3)}{3} + \frac{\pi(d^2)(h)}{4} \right] 64.0$$

$$\text{displ} = \frac{(32)^2 \pi r^3}{6} + 16\pi d^2 h$$

Rearranging

$$h = \frac{\text{displ}}{16\pi d^2} - 1.33d$$

Let $d = 4.0$ ft

then $h = 19.6$ ft

and total length of each tank = $19.6 + 4.0 = 23.6$ ft

Assume that each tank is an unstiffened shell fabricated from 1/4-inch plate.

Then the total weight of each tank is

$$wt = h\pi dt\gamma + 4\pi r^2 t\gamma$$

where h is the length of the cylinder minus end caps, d is the diameter of the cylinder, r is the radius of the cylinder, t is the thickness of the cylindrical shell, and γ is the specific weight of the steel.

$$wt = \frac{(19.6)(\pi)(4.0)(0.25)(480)}{12} + \frac{(4)(\pi)(4.0)(0.25)(480)}{12}$$

$$wt = 2,460 + 503 = 2,963 \text{ lb (dry)}, 2,570 \text{ lb (wet)}$$

The total volume displaced by the two tanks is 625 ft³.

2. Personnel Sphere. The personnel sphere would be designed for a collapse pressure of 10,000 feet. The sphere will have an outside diameter of 6.0 feet and will be constructed from HY-80 steel.

For thin-walled spherical pressure vessels

$$t = \frac{pr}{2\sigma}$$

where t is the required thickness, p is the design pressure, r is the radius and σ is the yield strength of the material.

$$t = \frac{(4.45 \times 10^3)(3.0)(12.0)}{(2)(8.00 \times 10^4)} = 1.00 \text{ in.}$$

A check will show that elastic-instability is not the critical failure mode. The sphere displaces 7,230 lb of water and has a dry weight (exclusive of internal furnishings and payload) of approximately 4,420 lb. The capsule payload will consist of two occupants and life support and communications gear. Total weight is estimated at around 1,000 lb. Consequently, the sphere has a positive buoyancy of $7,230 - 5,420 = 1,810$ lb.

3. Propulsion System and Power Requirement. The submersible should have an endurance of 10 hours and a cruising speed of at least 5 ft/sec. The required thrust can be estimated by solving for the fluid dynamic drag force

$$D = C_D (V^2/2g) \gamma A$$

where D is the drag force, C_D is a drag coefficient, V is the vehicle velocity, γ is the specific weight of the fluid medium and A is the cross-sectional area of the vehicle in the direction of motion. For the case at hand

$$\begin{aligned} C_D &= 0.30 \\ V &= 5.0 \text{ ft/sec} \\ \gamma &= 64.0 \text{ lb/ft}^3 \\ A &= 73 \text{ ft}^2 \text{ (est)} \end{aligned}$$

then

$$D = 545 \text{ lb}$$

A rule of thumb suggests that a 1 hp motor and propeller delivers approximately 25 lb of thrust. Therefore, $545/25 = 21.8$ hp are required. Two 10 hp motors will be used. Assuming 70% efficiency for the electric motors, the power requirement will be

$$20\text{hp} \times 0.746\text{kw/hp} \times 1.30 = 19.4\text{kw}$$

The total energy needed for propulsion will be 194 kw-hr. Additional stored energy will be needed to power lights, telechiric devices, and miscellaneous gear. This requirement is estimated at

20 kw-hr for 2 kw lamps

10 kw-hr for remaining gear

Total stored energy will then be about 224 kw-hr. Because of greater efficiency, silver/zinc batteries will be used which have a power density of 0.06 kw-hr/lb. The weight of the battery package will then be $224/0.06 = 3,740$ lb.

4. Helium Reservoirs. Because of its low density and nonflammable nature, high-pressure helium would be used for displacing water from the ballast tanks. The helium reservoirs will be constructed of HY-130 steel formed into spheres. A trade-off study was conducted to determine the most favorable weight to displacement ratio. The results are shown in table C-1. The constraints used in the analysis were that:

1. The maximum diameter of individual spheres would not exceed 6 feet. Large diameter spheres would be too unwieldy.
2. The maximum thickness of the spherical shell could not exceed 3 inches, since thicker sections would create unusually troublesome welding problems.
3. Six would be the maximum number of spheres allowed. A greater number would create the need for complex piping and valving and thus afford a greater chance for system failure.

The near optimum arrangement appears to be five, 6-foot diameter spheres with a wall thickness of 2.0 inches and an operating pressure of 7,650 psia. At this pressure, the stress in the spherical shells is one-half of the 130 ksi yield strength (safety factor of 2.0). Although this arrangement represents the most favorable weight to displacement ratio, the submerged weight of the sphere array is still 5,920 pounds. In order to insure near neutral buoyancy of the lift vehicle, this weight must be compensated for by the addition of syntactic foam.

Table C-1. Feasible Helium Reservoir Configurations

(Design safety factor for all vessels is 2.0.)

Diameter (ft)	Number Required	Total Volume (ft ³)	Shell Thickness (in.)	Dry Weight (lb)	Displacement (lb)	Submerged Weight (lb)	Internal Pressure (psi)
6.0	5	435	3.00	62,300	36,200	28,740	11,810
6.0	4	348	3.00	49,800	28,960	22,950	11,810
6.0	5	454	2.50	51,000	36,200	17,030	9,430
6.0	5	465	2.25	44,600	36,200	10,560	8,380
6.0	5	476	2.00	40,100	36,200	5,920 ¹	7,650
5.0	6	287	2.50	36,800	21,600	16,888	11,380
5.0	5	239	3.00	42,500	17,950	26,200	13,650
4.5	6	201	3.00	41,100	18,350	24,260	15,250

¹Optimum design.

5. Weight Balance.

Submerged Weight of Vehicle Subsystems

a.	Personnel Capsule	+ 1,810 lb
b.	Helium Reservoirs	– 5,920 lb
c.	Ballast Tanks	– 2,570 lb
d.	Frame (est)	– 4,000 lb
e.	Lifting Gear	– 2,000 lb
f.	Batteries and Propulsion System	– 5,000 lb
	Total	<u>–17,680 lb</u>

Thus, the vehicle needs 17,680 lb of permanent buoyancy. This would be provided by syntactic foam with a density of 40 lb/ft³.

$$\text{Foam vol} = \frac{17,680}{24.0} = 737 \text{ ft}^3$$

Dry Weight of Vehicle Subsystems

a.	Personnel Capsule	5,420 lb
b.	Helium Reservoirs	42,120 lb
c.	Ballast Tanks	2,963 lb
d.	Frame	4,000 lb
e.	Lifting Gear	2,000 lb
f.	Batteries and Propulsion System	5,000 lb
g.	Foam	<u>29,500 lb</u>
	Total	91,003 lb

Hydrazine Gas Generator System

This vehicle would share some of the subsystems of the pressurized helium vehicle, namely, the personnel sphere, the propulsion system, frame, and lifting gear.

The generator will use hydrazine with 5% ammonia and will produce 0.132 ft³ of noncondensable gas per pound of fuel. The generator will be similar to the one described in the Naval Ordnance Test Station (NOTS) report entitled, "Emergency Deballasting of Submersibles Using Liquid Gas Generator Systems."¹⁰ At an operating pressure of 2,670 psia, the generator will have to displace about 690 ft³ of water from the ballast tanks. Thus, each ballast tank, if 4 feet in diameter, will have a length including hemispherical end caps of 26.1 feet. Its weight will be 3,283 pounds dry and 2,850 pounds submerged. If 0.132 ft³ of gas per pound of fuel is produced, then $690/0.132 = 5,230$ lb of fuel will be required. Fuel density is 61.9 lb/ft³. A 12 hp pump will be used for pumping the hydrazine from the fuel bay into the reactant chamber. Since the deballasting rate is 100 lb/sec, approximately 7 minutes will be required to complete the job of expelling the 690 ft³ of water from the lift tanks. The pump will require an estimated (1.04) kw-hr of electric energy based on the following:

$$12\text{hp} \times 0.746 \text{ kw/hp} \times 7/60 = 1.04 \text{ kw-hr}$$

This additional power requirement is negligible compared with the 224 kw-hr needed for propulsion and lighting.

Submerged Weight of Vehicle Subsystems

a.	Personnel Capsule	+ 1,810 lb
b.	Gas Generator (est) including wt of fuel bags	- 2,000 lb
c.	Hydrazine Fuel	+ 177 lb
d.	Ballast Tanks	- 2,850 lb
e.	Frame (est)	- 4,000 lb

f.	Lifting gear	– 2,000 lb
g.	Batteries and Propulsion System	– 5,000 lb
	Total	– 13,863 lb

Thus, permanent buoyancy equivalent to 13, 863 lb is needed. This will be provided by 578 ft³ of syntactic foam.

Dry Weight of Vehicle Subsystems

a.	Personnel Capsule	5,420 lb
b.	Gas Generator	2,000 lb
c.	Hydrazine Fuel	5,240 lb
d.	Ballast Tanks	3,283 lb
e.	Frame	4,000 lb
f.	Lifting Gear	2,000 lb
g.	Batteries and Propulsion System	5,000 lb
h.	Foam	<u>23,100 lb</u>
	Total	50,043 lb

Vehicle With Rigid Cylindrical Lift Tanks

This vehicle would employ two ring-stiffened, cylindrical pressure vessels for a 20-ton lift capacity at 6,000 feet. The pressure vessels will be constructed out of HY-150 steel. For ring-stiffened cylinders with this yield strength, it has been found that the hull weight is approximately equal to 53% of the submerged displacement. Therefore, for a diameter of 5.0 feet and a length of 45 feet, the displacement of each cylindrical tank is

$$\text{displ} = \left[\frac{(\pi) (25.) (40.0)}{4} + \frac{(4) (\pi) (15.6)}{3} \right] 64.0 = 54,500 \text{ lb}$$

The hull weight is

$$(0.53) (54,400) = 28,800 \text{ lb}$$

and the buoyancy of each tank is equal to

$$\frac{54,400 - 28,800}{2,000} = 12.8 \text{ tons}$$

Frame, personnel capsule, and lifting gear as used in the two previous designs is assumed compatible with the present design. Since the lift tanks are larger in diameter than the ballast tanks used for the hydrazine vehicle or the high-pressure helium vehicle, they will create additional drag which must be accounted for by redesign of the propulsion and power systems. The increase in cross-sectional area is equal to the cross-sectional area of the rigid steel tanks minus the cross-sectional area of the hydrazine vehicle deballasting tanks

$$\frac{(2) (\pi) (25.0)}{4} - \frac{(2) (\pi) (16.0)}{4} = 14.2 \text{ ft}^2 \text{ (say 14 feet)}$$

The new total cross-sectional area becomes

$$73 + 14 = 87 \text{ ft}^2$$

and proceeding as before

$$D = \frac{C_D V^2 \gamma A}{2}$$

$$D = \frac{(0.30) (25.0) (64.0) (87.0)}{(2) (32.2)} = 648 \text{ lb}$$

and $648/25.0 = 25.9$ hp required. Two motors rated at 13 hp will be used. Assuming 70% efficiency, the power requirement will be:

$$26 \text{ hp} \times 0.746 \text{ kw/hp} \times 1.30 = 25.2 \text{ kw}$$

and for a 10-hour mission, 252 kw-hr of energy must be stored. The total energy to be supplied by silver/zinc storage cells is 282 kw-hr which will require about $282/0.06 = 4,700$ lb of cells.

Submerged Weight of Vehicle Subsystems

a. Personnel Capsule	+ 1,810 lb
b. Lift Tanks	+ 51,250 lb
c. Frame	- 4,000 lb
d. Lifting Gear	- 2,000 lb
e. Batteries and Propulsion System	- 6,500 lb
	<hr/>
Total	+ 40,560 lb

An expendable ballast weight, assumed here to be concrete, weighing 40,560 pounds (wet) will be needed to compensate for the excess buoyancy created by the lift tanks.

Dry Weight of Vehicle Subsystems

a. Personnel Capsule	5,420 lb
b. Lift Tanks	28,800 lb
c. Frame	4,000 lb
d. Lifting Gear	2,000 lb

e.	Batteries and Propulsion System	6,500 lb
f.	Ballast Weight	70,750 lb
		<hr/>
	Total	117,470 lb

HYDROCOPTER

Propulsion System

The propulsion system would consist of three, Voith-Schneider model 24E cycloidal propellers with the following specifications:^{37, *}

1.	Overall Diameter	10.3 ft
2.	Length	8.7 ft
3.	Weight	35,062 lb
4.	Static Thrust	20,000 lb
5.	Approx Unit Price	\$95,500

Three 1,000 hp horizontal induction motors will drive the cycloidal propellers. Motor specifications are:

1.	Power	1,000 hp at 227 rpm
2.	Weight	5,503 lb (includes motor frame)
3.	Dimensions	106.4 by 80 by 54.5 in.
4.	Line Voltage	2,300 volts

Hull

The basic hull structure would be constructed from HY-80 steel. The three ring-stiffened lift tanks would be fabricated from HY-150 steel and have a net weight equal to approximately 53% of their submerged

* Based on table titled "Main Dimensions of the Voith-Schneider Propeller" in "Recommendations for the Installation of Voith-Schneider Propellers," copyrighted by J. M. Voith GMBH, Heidenheim (Brenz), Germany.

displacement. The toroidal hull will accommodate three cycloidal propellers with rotor axes lying in the plane of the toroid. A steel, titanium, or titanium-glass composite spherical personnel capsule will fit into the center of the toroid.

Vehicle Weight

Three components are responsible for most of the vehicle weight. Their estimated weights are:

1. Lift Tanks	166,000 lb
2. Propellers and Motors	61,650 lb
3. Toroidal Hull and Miscellaneous Equipment	86,000 lb
	<hr/>
Total	313,650 lb

The buoyancy of the lift tanks is estimated at 314,000 pounds.

REFERENCES

1. Navy Electronics Laboratory. Technical Memorandum TM-986: Hydrodynamic winch, by E. N. Rosenberg. San Diego, Calif., Sept. 1966.
2. Naval Civil Engineering Laboratory. A proposal: For the development of a hydrodynamic winch for deep ocean engineering. Port Hueneme, Calif., Feb. 1965.
3. ————. Contract Report CR 68.012: Concept development of manned underwater station. Groton, Conn., General Dynamics Corporation, Electric Boat Division, July 1968, 2 vols. (Contract N62399-67-C-0044) (AD 841546L, vol. 1; AD 841350L, vol. 2)
4. ————. Technical Note: Review of ocean load lifting/lowering systems, by D. A. Davis. Port Hueneme, Calif. (IN PREPARATION)
5. "Alcoa, OSE building aluminum ship for search, recovery work," Ocean Industry, vol. 3, no. 8, Aug. 1968, p. 11.
6. D. M. Taylor. "The Challenger's adventure begins," Ocean Industry, vol. 3, no. 10, Oct. 1968, pp. 35-50.
7. J. Ray McDermott and Company, Inc. Report on Contract NBy-37640: Feasibility study of a Floating Ocean Research and Development Station (FORDS), phase 1A, summary. New Orleans, La., Apr. 1964. (AD 438814)
8. Wire Rope Technical Board letter to D. A. Davis of NCEL, concerning rope closing machine. Washington, D. C., Jan. 6, 1969.
9. Naval Civil Engineering Laboratory. Unpublished report: Buoyancy assistance for cable lift systems, by D. B. Jones. Port Hueneme, Calif., undated.
10. Naval Ordnance Test Station. Memorandum no. 4582-042: Emergency deballasting of submersibles using liquid gas generator systems, by J. Witcher and J. O. Drake. China Lake, Calif., June 1966.

11. L. H. Hallanger. "DIVERCON I: A diver construction experiment, development problems and solutions," paper presented at American Society of Mechanical Engineers Underwater Technology Conference, San Diego, Calif., Mar. 9-12, 1969. (ASME paper no. 69-UN-T - 10)
12. Jacobson Brothers, Inc. Brochure: Underwater search and recovery systems. Seattle, Wash., undated.
13. Dortech Incorporated. Special qualification report for GSE development, design, fabrication, test and installation. Stamford, Conn., Jan. 1968.
14. Naval Civil Engineering Laboratory. Unpublished report: Deep-ocean lifting, transporting and positioning systems, by H. M. Kusano. Port Hueneme, Calif., Oct. 1968.
15. ———. Technical Report R- : An evaluation of deep ocean research vehicles, by J. B. Ciani. Port Hueneme, Calif. (TO BE PUBLISHED)
16. UnderSea Technology handbook directory 1968. Arlington, Va., Compass Publications, 1968, pp. B/33-B/36.
17. G. L. Hittleman and C. L. Stridland. "The application of incandescent, mercury vapor, and thallium iodide lighting to underwater tasks," in Proceedings of the SPIE Seminar of Underwater Photo-Optical Instrumentation Applications, San Diego, Calif., Feb. 5-6, 1968. Redondo Beach, Calif., Society of Photo-Optical Instrumentation Engineers, 1968, p. 163. (Whole article pp. 153-165)
18. J. L. Lingery. "A study of underwater color saturation recording," in Proceedings of the SPIE Seminar of Underwater Photo-Optical Instrumentation Applications, San Diego, Calif., Feb. 5-6, 1968. Redondo Beach, Calif., Society of Photo-Optical Instrumentation Engineers, 1968, pp. 51-61.
19. General Motors Corporation. AC Electronics-Defense Research Laboratories. Report S68-13: Acoustic guidance sonar. Goleta, Calif., Aug. 1968.
20. P. C. Curzan of AC Electronics-Defense Research Laboratories, letter to J. A. Drelicharz of NCEL, concerning acoustic guidance sonar display. Goleta, Calif., Mar. 21, 1969.

21. Chief of Naval Material (Development). Technical Development Plan 46-36X: Deep Ocean Technology project (U). Washington, D.C., May 1968, p. 8.53 CONFIDENTIAL (Rev. ed. Apr. 1969)
22. G. M. Gray. "Capability and cost interactions in deep submersible vehicles," in A critical look at marine technology; proceedings of the 4th annual MTS conference and exhibit, July 8-10, 1968. Washington, D.C., Marine Technology Society, 1968, p. 488. (Whole article pp. 485-502)
23. J. H. Beno and J. W. Clark. "Deep sea robots," UnderSea Technology, vol. 3, no. 1, Jan-Feb 1962, pp. 23-24.
24. Bechtel Corporation. Report on Contract NBy-32273: Research and development study for deep ocean reactor placement. San Francisco, Calif., May 1965, p. 3-1. (Prepared in cooperation with M. Rosenblatt & Son, San Francisco, Calif.) (AD 466696)
25. Naval Civil Engineering Laboratory. Technical Report R-284-7: Structures in deep ocean engineering manual for underwater construction, chap. 7. Buoys and anchorage systems, by J. E. Smith. Port Hueneme, Calif., Oct. 1965, pp. 4.11-4.21. (AD 473928)
26. W. J. Tudor. "Hydrodynamics and responses," in Naval Civil Engineering Laboratory, Technical Report R-345: Deep ocean civil engineering, back-up report, Undersea Technology Panel, Project SEABED, by O. B. Crumpler, et al. Port Hueneme, Calif., Sept. 1964, p. 5.5. OUO (AD 457974)
27. K. W. Foster. "Dynamic anchoring of floating vessels," in Exploiting the ocean; transactions of the 2nd annual MTS conference and exhibit, June 27-29, 1966. Washington, D.C., Marine Technology Society, 1966, pp. 158-172.
28. C. K. Paul. "Locating, surveying, and mapping," in Naval Civil Engineering Laboratory, Technical Report R-345: Deep ocean civil engineering, back-up report, Undersea Technology Panel, Project SEABED, by O. B. Crumpler, et al. Port Hueneme, Calif., Sept. 1964, pp. 2.1-2.10. OUO (AD 457974)

29. Naval Civil Engineering Laboratory. Technical Report R-284-3: Structures in deep ocean engineering manual for underwater construction, chap. 3. Reconnaissance and positioning, by T. T. Lee. Port Hueneme, Calif., Mar. 1964, pp. 1.7-1.8. (AD 600305)
— see also # 28, pp. 2.1-2.4
30. Naval Civil Engineering Laboratory. Technical Report R-433: Mechanics of raising and lowering heavy loads in the deep ocean: cable and payload dynamics, by P. Holmes. Port Hueneme, Calif., Apr. 1966. (AD 631267)
31. ————. Technical Note N-760: Construction equipment for handling heavy loads in the ocean, by B. J. Muga. Port Hueneme, Calif., Mar. 1966. (AD 808820L)
32. J. Ray McDermott and Company, Inc. Report on Contract NBy-37640: Feasibility study of a Floating Ocean Research and Development Station (FORDS), phase 1A. New Orleans, La., Apr. 1964. 4 vols. (AD 438811, vol. 1; AD 438812, vol. 2; AD 438813, vol. 3; AD 438814, Summary vol.)
33. R. J. Roark. Formulas for stress and strain, 4th ed. New York, McGraw-Hill, chap. 10, pp. 214-258.
34. David Taylor Model Basin. Report no. 1957: Seaworthiness tests on a model of a T-2 tanker with a well arrangement near amidships, by S. S. Hagara. Washington, D.C., June 1966. (AD 486546L)
35. National Academy of Sciences. Publication 984: Design of a deep ocean drilling ship. Washington, D.C., 1962.
36. David Taylor Model Basin. Report no. 1855: Motion characteristics of NRL Platform (FORDS) in waves, by J. Foster. Washington, D.C., Aug. 1964. (AD 605374)
37. J. M. Voith GMBH. Brochure 1584e: Recommendations for the installation of Voith-Schneider propellers. Heidenheim (Brenz), Germany, 1965, p. 3. (U. S. representative: Pacific Car and Foundry Co., Renton, Wash.)

DISTRIBUTION LIST

SNDL Code	No. of Activities	Total Copies	
—	1	20	Defense Documentation Center
FKAIC	1	10	Naval Facilities Engineering Command
FKNI	13	13	NAVFAC Engineering Field Divisions
FKN5	9	9	Public Works Centers
FA25	1	1	Public Works Center
—	14	14	RDT&E Liaison Officers at NAVFAC Engineering Field Divisions and Construction Battalion Centers
—	314	314	NCEL Special Distribution List No. 9 for persons and activities interested in reports on Deep Ocean Studies

Naval Civil Engineering Laboratory
FEASIBILITY STUDY AND COMPARATIVE ANALYSIS OF
DEEP OCEAN LOAD HANDLING SYSTEMS (Final),
by D. A. Davis and M. J. Wolfe
TR-652 155 p. illus December 1969 Unclassified

1. Submerged heavy load handling—Deep ocean I. YF 38.535.003.01.007A
- Nine candidate systems for lowering and raising negatively buoyant loads in the deep ocean were compared and evaluated by means of a systems effectiveness model. For both load ranges considered — 20 to 100 tons and 400 to 600 tons at 6,000 feet — a lift system employing a ship with pipe string suspension medium was considered to be the most feasible approach. Accurate positioning of heavy modular loads can be most readily achieved by resorting to acoustic devices for guiding the translation and rotation of the surface support craft prior to final emplacement. A manned submersible would serve as a useful guidance backup system. The transport of 10- to 30-ton loads for short distances in the near bottom environment is considered feasible. Final choice between two competing systems, a heavy-life submersible and a hydrocopter, must await further definition of work missions and load configurations.

Naval Civil Engineering Laboratory
FEASIBILITY STUDY AND COMPARATIVE ANALYSIS OF
DEEP OCEAN LOAD HANDLING SYSTEMS (Final),
by D. A. Davis and M. J. Wolfe
TR-652 155 p. illus December 1969 Unclassified

1. Submerged heavy load handling—Deep ocean I. YF 38.535.003.01.007A
- Nine candidate systems for lowering and raising negatively buoyant loads in the deep ocean were compared and evaluated by means of a systems effectiveness model. For both load ranges considered — 20 to 100 tons and 400 to 600 tons at 6,000 feet — a lift system employing a ship with pipe string suspension medium was considered to be the most feasible approach. Accurate positioning of heavy modular loads can be most readily achieved by resorting to acoustic devices for guiding the translation and rotation of the surface support craft prior to final emplacement. A manned submersible would serve as a useful guidance backup system. The transport of 10- to 30-ton loads for short distances in the near bottom environment is considered feasible. Final choice between two competing systems, a heavy-life submersible and a hydrocopter, must await further definition of work missions and load configurations.

Naval Civil Engineering Laboratory
FEASIBILITY STUDY AND COMPARATIVE ANALYSIS OF
DEEP OCEAN LOAD HANDLING SYSTEMS (Final),
by D. A. Davis and M. J. Wolfe
TR-652 155 p. illus December 1969 Unclassified

1. Submerged heavy load handling—Deep ocean I. YF 38.535.003.01.007A
- Nine candidate systems for lowering and raising negatively buoyant loads in the deep ocean were compared and evaluated by means of a systems effectiveness model. For both load ranges considered — 20 to 100 tons and 400 to 600 tons at 6,000 feet — a lift system employing a ship with pipe string suspension medium was considered to be the most feasible approach. Accurate positioning of heavy modular loads can be most readily achieved by resorting to acoustic devices for guiding the translation and rotation of the surface support craft prior to final emplacement. A manned submersible would serve as a useful guidance backup system. The transport of 10- to 30-ton loads for short distances in the near bottom environment is considered feasible. Final choice between two competing systems, a heavy-life submersible and a hydrocopter, must await further definition of work missions and load configurations.

Naval Civil Engineering Laboratory
FEASIBILITY STUDY AND COMPARATIVE ANALYSIS OF
DEEP OCEAN LOAD HANDLING SYSTEMS (Final),
by D. A. Davis and M. J. Wolfe
TR-652 155 p. illus December 1969 Unclassified

1. Submerged heavy load handling—Deep ocean I. YF 38.535.003.01.007A
- Nine candidate systems for lowering and raising negatively buoyant loads in the deep ocean were compared and evaluated by means of a systems effectiveness model. For both load ranges considered — 20 to 100 tons and 400 to 600 tons at 6,000 feet — a lift system employing a ship with pipe string suspension medium was considered to be the most feasible approach. Accurate positioning of heavy modular loads can be most readily achieved by resorting to acoustic devices for guiding the translation and rotation of the surface support craft prior to final emplacement. A manned submersible would serve as a useful guidance backup system. The transport of 10- to 30-ton loads for short distances in the near bottom environment is considered feasible. Final choice between two competing systems, a heavy-life submersible and a hydrocopter, must await further definition of work missions and load configurations.

Naval Civil Engineering Laboratory
FEASIBILITY STUDY AND COMPARATIVE ANALYSIS OF
DEEP OCEAN LOAD HANDLING SYSTEMS (Final),
by D. A. Davis and M. J. Wolfe
TR-652 155 p. illus December 1969 Unclassified

1. Submerged heavy load handling—Deep ocean I. YF 38.535.003.01.007A

Nine candidate systems for lowering and raising negatively buoyant loads in the deep ocean were compared and evaluated by means of a systems effectiveness model. For both load ranges considered — 20 to 100 tons and 400 to 600 tons at 6,000 feet — a lift system employing a ship with pipe string suspension medium was considered to be the most feasible approach. Accurate positioning of heavy modular loads can be most readily achieved by resorting to acoustic devices for guiding the translation and rotation of the surface support craft prior to final emplacement. A manned submersible would serve as a useful guidance backup system. The transport of 10- to 30-ton loads for short distances in the near bottom environment is considered feasible. Final choice between two competing systems, a heavy-life submersible and a hydrocopter, must await further definition of work missions and load configurations.

Naval Civil Engineering Laboratory
FEASIBILITY STUDY AND COMPARATIVE ANALYSIS OF
DEEP OCEAN LOAD HANDLING SYSTEMS (Final),
by D. A. Davis and M. J. Wolfe
TR-652 155 p. illus December 1969 Unclassified

1. Submerged heavy load handling—Deep ocean I. YF 38.535.003.01.007A

Nine candidate systems for lowering and raising negatively buoyant loads in the deep ocean were compared and evaluated by means of a systems effectiveness model. For both load ranges considered — 20 to 100 tons and 400 to 600 tons at 6,000 feet — a lift system employing a ship with pipe string suspension medium was considered to be the most feasible approach. Accurate positioning of heavy modular loads can be most readily achieved by resorting to acoustic devices for guiding the translation and rotation of the surface support craft prior to final emplacement. A manned submersible would serve as a useful guidance backup system. The transport of 10- to 30-ton loads for short distances in the near bottom environment is considered feasible. Final choice between two competing systems, a heavy-life submersible and a hydrocopter, must await further definition of work missions and load configurations.

Naval Civil Engineering Laboratory
FEASIBILITY STUDY AND COMPARATIVE ANALYSIS OF
DEEP OCEAN LOAD HANDLING SYSTEMS (Final),
by D. A. Davis and M. J. Wolfe
TR-652 155 p. illus December 1969 Unclassified

1. Submerged heavy load handling—Deep ocean I. YF 38.535.003.01.007A

Nine candidate systems for lowering and raising negatively buoyant loads in the deep ocean were compared and evaluated by means of a systems effectiveness model. For both load ranges considered — 20 to 100 tons and 400 to 600 tons at 6,000 feet — a lift system employing a ship with pipe string suspension medium was considered to be the most feasible approach. Accurate positioning of heavy modular loads can be most readily achieved by resorting to acoustic devices for guiding the translation and rotation of the surface support craft prior to final emplacement. A manned submersible would serve as a useful guidance backup system. The transport of 10- to 30-ton loads for short distances in the near bottom environment is considered feasible. Final choice between two competing systems, a heavy-life submersible and a hydrocopter, must await further definition of work missions and load configurations.

Naval Civil Engineering Laboratory
FEASIBILITY STUDY AND COMPARATIVE ANALYSIS OF
DEEP OCEAN LOAD HANDLING SYSTEMS (Final),
by D. A. Davis and M. J. Wolfe
TR-652 155 p. illus December 1969 Unclassified

1. Submerged heavy load handling—Deep ocean I. YF 38.535.003.01.007A

Nine candidate systems for lowering and raising negatively buoyant loads in the deep ocean were compared and evaluated by means of a systems effectiveness model. For both load ranges considered — 20 to 100 tons and 400 to 600 tons at 6,000 feet — a lift system employing a ship with pipe string suspension medium was considered to be the most feasible approach. Accurate positioning of heavy modular loads can be most readily achieved by resorting to acoustic devices for guiding the translation and rotation of the surface support craft prior to final emplacement. A manned submersible would serve as a useful guidance backup system. The transport of 10- to 30-ton loads for short distances in the near bottom environment is considered feasible. Final choice between two competing systems, a heavy-life submersible and a hydrocopter, must await further definition of work missions and load configurations.

DOCUMENT CONTROL DATA - R & D

(Security classification of title, body of abstract and indexing annotation must be entered when the overall report is classified)

1. ORIGINATING ACTIVITY (Corporate author) Naval Civil Engineering Laboratory Port Hueneme, California 93041		2a. REPORT SECURITY CLASSIFICATION Unclassified	
		2b. GROUP	
3. REPORT TITLE FEASIBILITY STUDY AND COMPARATIVE ANALYSIS OF DEEP OCEAN LOAD HANDLING SYSTEMS			
4. DESCRIPTIVE NOTES (Type of report and inclusive dates) Final; October 1968 - June 1969			
5. AUTHOR(S) (First name, middle (initial), last name) D. A. Davis and M. J. Wolfe			
6. REPORT DATE December 1969		7a. TOTAL NO. OF PAGES 155	7b. NO. OF REFS 37
8a. CONTRACT OR GRANT NO.		9a. ORIGINATOR'S REPORT NUMBER(S) TR-652	
b. PROJECT NO. YF 38.535.003.01.007A		9b. OTHER REPORT NO(S) (Any other numbers that may be assigned this report)	
c.			
d.			
10. DISTRIBUTION STATEMENT This document has been approved for public release and sale; its distribution is unlimited.			
11. SUPPLEMENTARY NOTES		12. SPONSORING MILITARY ACTIVITY Naval Facilities Engineering Command Washington, D. C.	
13. ABSTRACT Nine candidate systems for lowering and raising negatively buoyant loads in the deep ocean were compared and evaluated by means of a systems effectiveness model. For both load ranges considered - 20 to 100 tons and 400 to 600 tons at 6,000 feet - a lift system employing a ship with pipe string suspension medium was considered to be the most feasible approach. Accurate positioning of heavy modular loads can be most readily achieved by resorting to acoustic devices for guiding the translation and rotation of the surface support craft prior to final emplacement. A manned submersible would serve as a useful guidance backup system. The transport of 10- to 30-ton loads for short distances in the near bottom environment is considered feasible. Final choice between two competing systems, a heavy-life submersible and a hydrocopter, must await further definition of work missions and load configurations.			

Unclassified

Security Classification

14. KEY WORDS	LINK A		LINK B		LINK C	
	ROLE	WT	ROLE	WT	ROLE	WT
Load handling systems						
Deep ocean						
Near-bottom environment						
Pipe-string lift system						
Emplacement of heavy loads						
Underwater TV						
Acoustic location devices						
Underwater Laser systems						
Transport of near-bottom loads						
Heavy-lift submersible						
Hydrocopter						
Bottom crawler						



NAVAL CIVIL ENGINEERING
LABORATORY
PORT HUENEME, CALIFORNIA 93041

IN REPLY REFER TO:
L36/OWC/jd
YF 38.535.003.01
Serial 459
6 Mar 1970

From: Commanding Officer
To: Distribution List

Subj: Errata Sheet for Technical Report R-652, "Feasibility Study and Comparative Analysis of Deep Ocean Load Handling Systems," by D. A. Davis and M. J. Wolfe

Encl: (1) Reworked, reprinted pages 17, 18, 23, 24, 127, 128, 129, 130, 131, 132, 133, 134

1. Please remove the above pages from your copy of TR-652 and insert the new corrected ones.

J. G. HAMMER
By direction

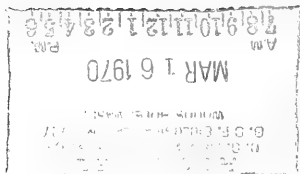

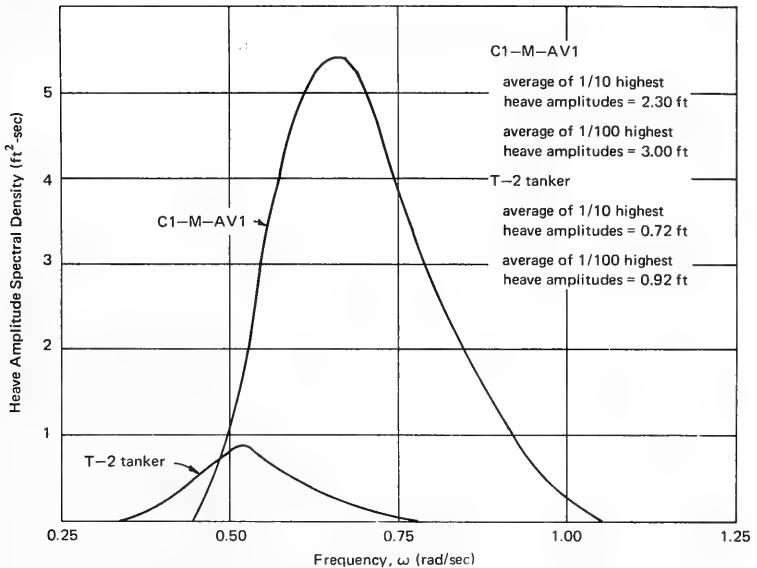

Figure 4. Heave amplitude spectra for T-2 tanker and C1-M-AV1 with 20-knot wind and fully developed sea.

Material. Aluminum and steel are the two most common materials used for pipe. It is readily apparent from even the most cursory glance at the literature that aluminum pipe is not suitable for lifting heavy loads. While some aluminum drill pipe has been used in the offshore drilling industry, the loads subjected to the pipe have been comparably mild. In addition, while some grades of aluminum are possibly suitable for heavy-lift applications, it has been found that readily available aluminum pipe is either not made of the stronger grades or is much too small for the loads in question.

High-grade steel is recommended for manufacturing pipe used to support heavy loads. Steels of minimum yield strengths in the range of 110,000 to 150,000 psi are the most suitable for the purposes of this project. Table 3 summarizes the important properties of two steels meeting these requirements.

Table 3. High-Grade Pipe Steels

(Source: FORDS Study, Table XI-8, Volume I)

Steel Grade	Properties	
P-110	Minimum Yield Strength	110,000 psi
	Minimum Tensile Strength	125,000 psi
	Average Elongation in 2 Inches	15%
V-150	Minimum Yield Strength	150,000 psi
	Yield Strength Maximum	171,000 psi
	Average Elongation in 2 Inches	19%

Pipes over 13 inches in diameter have been manufactured using P-110 and V-150 steels (Reference 7, p. S-45). Table 4 presents some relevant design parameters for a suitable range of pipe diameters. These pipes are off-the-shelf items and come in lengths of about 50 feet.

Couplings. Table 5 illustrates how the strengths of typical pipe joints compare with the strength of the pipe. It can be seen that the joints are at least 90% efficient and in two cases are actually stronger than the pipe. The joints are of the "shrink grip" variety, which is very similar to the standard plumbing coupling used in home water systems.

Design. Assuming a safety factor of two for static loading and limiting attention to the severest case of a 600-ton load at 6,000 feet, it can be shown that of the different pipes listed in Table 4, only the last three of V-150 grade steel will meet the requirements. These are 10-3/4-inch OD weighing 71.1, 76.0, and 81.0 pounds per foot, respectively.

It is obvious that at lesser depths and/or with lesser loads the static safety factor would increase.

The combined static force of the pipe string and load is necessary but not sufficient for a realistic design analysis of the pipe system. There are two types of dynamic loading that must be considered in a complete investigation: (1) loads incurred during sudden stops and (2) loads imposed on the pipe due to ship motion.

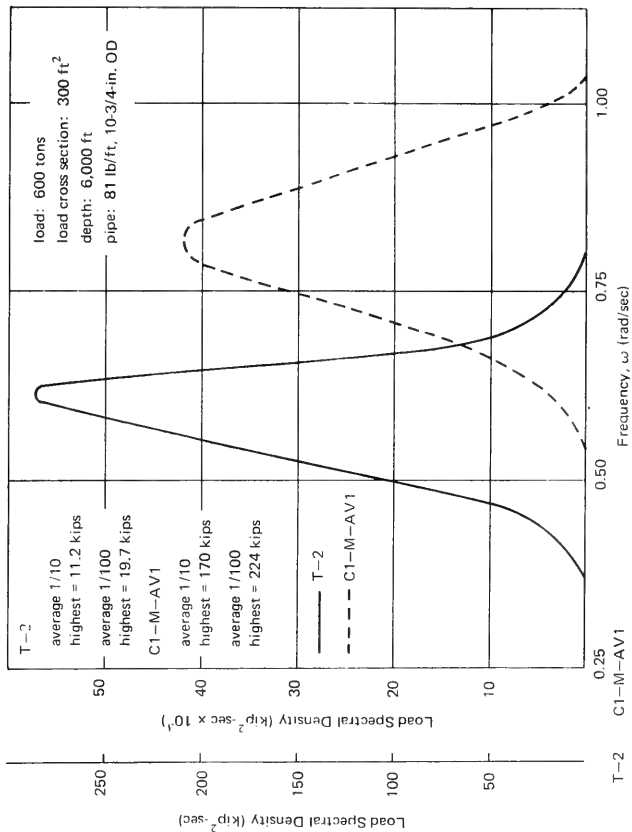

Figure 6. Dynamic load spectra for T-2 tanker and C1-M-AV1 with 20-knot wind and fully developed sea.

Cable

Candidates employing cable as the suspending medium were examined in much the same manner as pipe systems. In general, the same types of questions were necessarily asked and answered. The state-of-the-art, projected future capabilities, the magnitude and types of loadings, and anticipated problem areas were given most of the emphasis in the study of the "flexible support" concepts.

There are two contenders: wire rope and synthetic rope. Both types have been widely used in ocean-related industries. The desirable and undesirable features of each are well-documented and in many cases are common knowledge.

Synthetic Rope. There are three primary types of materials used for manufacturing synthetic cables: nylon, dacron, and polypropylene. Nylon was the first of the synthetic fiber cables. It has a slight negative buoyancy in water and has a good deal of permanent elongation. Dacron is stronger than nylon but is not generally available in large diameter cables. Polypropylene is slightly less strong than nylon but has the added asset of slightly positive buoyancy; it is available in diameters up to 5 inches with breaking strengths on the order of 600,000 pounds.

Primary advantages of synthetic fiber cables are that they are comparatively buoyant, so no strength is lost due to cable weight, and that they are available in construction which does not twist under load. Disadvantages include a high degree of elasticity, susceptibility to fish bites, and a requirement for large storage areas for large diameter ropes.

Wire Rope. Wire rope is a mainstay of the ocean industries. Its development has closely paralleled the improvements in high-strength steels. It is possible to purchase high-strength rope in lengths up to 5,000 feet, 4 inches in diameter, 6 x 61 classification. This rope is used in dredging operations and has a breaking strength of 713 tons. It is flexible enough to be used as a hoisting rope. The continuous length of a rope that can be manufactured is limited by the weight-handling capacity of the wrapping machines, which is 80 tons.⁸ As a result, the maximum lengths of 4-inch, 3-3/4-inch, and 3-1/2-inch ropes are 5,420 feet, 6,160 feet, and 7,070 feet, respectively. The development of greater capacity rope would require substantial industry wide demand.

For reasons of safety and to account for the susceptibility of cable to dynamic loading, a safety factor of at least five is recommended for most usages. This high factor also takes into consideration the relatively low

Response of a Converted T-2 Tanker³⁴

The T-2 tanker has been found to be one of the best of the currently available ships for conversion to special applications such as heavy lift. For example, Project ARTEMIS, which required lifts of approximately 190 tons to 1,200 feet, employed a converted T-2 tanker with a large free-flooding well near the center. The principal characteristics and dimensions of the enlarged T-2 tanker used in Project ARTEMIS are as follows:

Length	503 feet
Beam	68 feet
Mean draft	27 feet
Displacement	17,000 long tons
Natural pitching period	7.0 seconds
Natural heaving period	7.2 seconds
Natural rolling period	12.2 seconds

The T-2 tanker is a relatively large ship which has power sufficient to support a heavy-lift system. It is fairly stable and is large enough to provide ample room for both facilities and crew. However, most T-2 tankers are showing signs of age, thereby making it doubtful that one could be converted to heavy-lift operations without extensive modifications. Nevertheless, the amounts of heave, pitch, etc. of the T-2 in a fully developed sea are excellent inputs for computing the dynamic stresses imposed on lines suspended from ships of this size.

Of interest is a report entitled "Seaworthiness Tests on a Model of a T-2 Tanker With a Well Arrangement Near Amidships."³⁴ This report is concerned primarily with the effect of the well on the heave and pitch of the ship. The motions of the ship were observed in a fully developed sea state 5 with 21-knot winds. Table B-6 summarizes the average heave amplitudes for a T-2 tanker.

To get a better grasp on exactly how the ship heaves, the response amplitude operators for heave motion in long-crested seas is multiplied by the Neumann spectrum. The result is shown in Figure B-12. The figures in the graph compare favorably with those in Table B-6.

Assuming that the sea is in a steady-state condition, it is then possible to compute the axial force due to heave in the pipe string by multiplying the value of the heave spectrum by the force/heave diagram derived earlier. Figure B-13 illustrates the relationships between dynamic force and heave period for a T-2 tanker. There is little possibility of these values being exceeded. The graph indicates that the maximum dynamic stress is considerably less than 5% of the static stress.

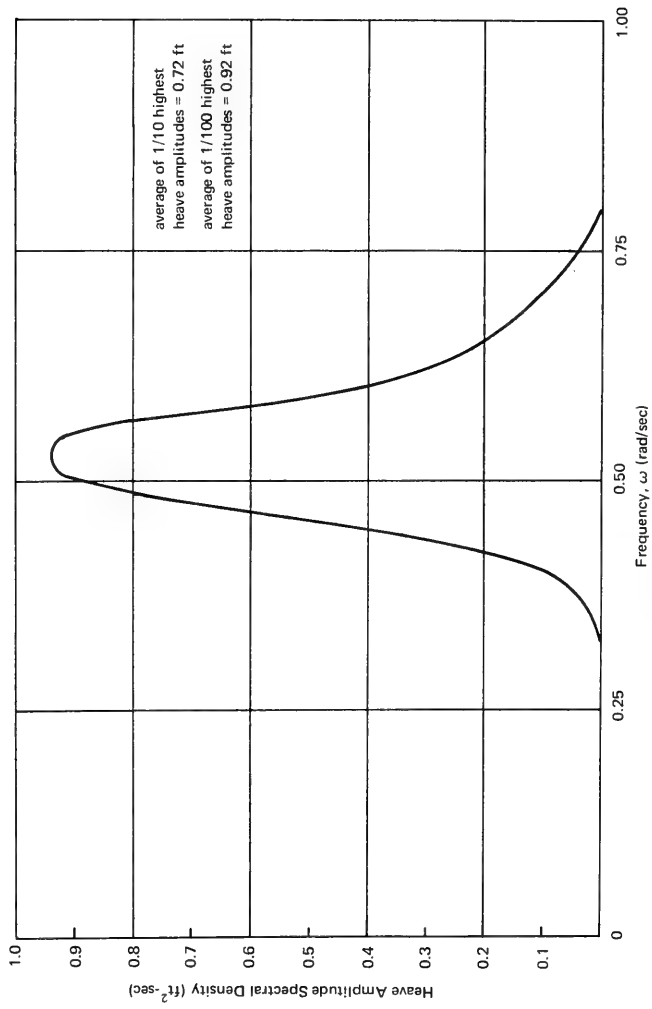

Figure B-12. Heave amplitude spectrum for T-2 tanker with 20-knot wind and fully developed sea.

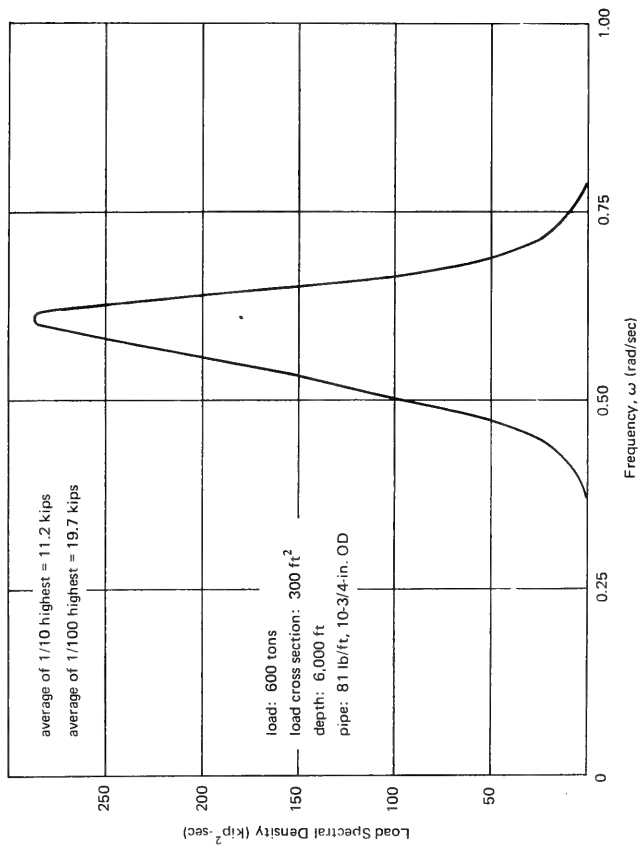

Figure B-13. Dynamic load spectrum for 7-2 tanker with 20-knot wind and fully developed sea.

Table B-6. Response Characteristics of a **T-2** Tanker¹

Ship Speed (knots)	1/3 Highest Amplitude		1/10 Highest Amplitude	
	Pitch (degrees)	Heave (ft)	Pitch (degrees)	Heave (ft)
0	0.78	0.77	0.97	0.98
5	0.92	---	1.17	---
10	1.11	---	1.42	---
15	1.10	1.06	1.40	1.35

¹ Reference 34, p. 5

A conclusion reached from the above is that a **T-2** tanker or a ship of similar size would safely support a pipe string-load combination in all but the severest sea states. There is some question whether the equipment necessary to handle and support the pipe string could be installed on the tanker. Up to the present, **T-2** tankers used for heavy-lift operations have used cable-winch systems to lower the load. It would appear at first glance that it would be no more difficult to install pipe handling equipment on the **T-2** than on the *Cuss I*. Therefore, a **T-2** tanker or comparable ship would be worthy of serious consideration in the heavy-lift project.

Response of the *C1-M-AV1*³⁵

The *C1-M-AV1* has been analyzed in some detail for use as a deep ocean drilling ship. This ship was at one time considered ideal for a test bed for the MOHOLE project. Its response would be very much the same as present drilling ships. The pertinent specifications are as follows:

Length	338 feet
Beam	50 feet
Full load displacement	7,400 tons

The wave amplitude spectrum describing a specific sea condition is needed to calculate the ship response spectra. Assuming a fully developed sea with a 20-knot wind, the following values can be determined:

Average wave height	5.0 feet
1/10 highest height	10.0 feet
1/1,000 highest height	15.0 feet

Calculation of the response motions of the ship in the above sea state can be complicated. However, by use of some simplifying assumptions (primarily eliminating nonlinearities), the amplitude response of the *C1-M-AV1* in head-on heave can be arrived at with a minimum of difficulty. The results are plotted in Figure B-14.

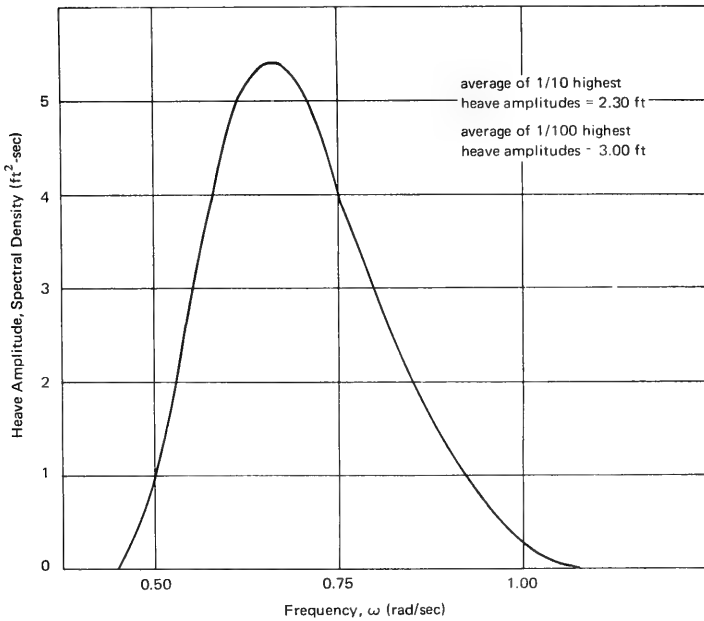

Figure B-14. Amplitude spectrum, combined pitch and heave, of a *C1-M-AV1* in a 20-knot fully developed sea.*

* After Figure 34 reference 35.

It can be seen that the *C1-M-AV1* will not respond to waves of periods of about 6 seconds, while it will move with waves of periods greater than 14 seconds. The average amplitude for the highest one-tenth of the heave motions is 2.30 feet for a total motion of 4.60 feet. Figure B-15 illustrates the relationship between dynamic axial force and the frequency of oscillation. The values are for average amplitudes and could increase significantly if conditions changed.

It appears that the ship used for heavy lift will need a longer period in heave than the *C1-M-AV1* or if that is found to be difficult to achieve, some type of heave compensating mechanism is needed to reduce the effects of vertical motion. The latter approach is being used on the *Alcoa Seaprobe*, where a heave compensating crown block will be installed. As far as is known, this is the first ship using such a device; much success is predicted by the designers.

Motion of *FORDS*³⁶

Probably the ultimate in stable platforms so far proposed is the Naval Research Laboratory's Floating Ocean Research and Development Station (*FORDS*). While the prototype was never constructed, models of the platform were tested in the David Taylor Model Basin. The results of the investigation illustrate the response characteristics of the platform in some detail.

Two important test conditions were studied in the experiments:

<u>Condition</u>	<u>Draft (ft)</u>	<u>Weight (long tons)</u>	<u>Natural Period in Heave (sec)</u>
1	30	13,510	5.3
2	265	19,220	123.3

The light draft motions (test condition no. 1) are comparable in magnitude to those of a ship of the same displacement.

Figure B-16 illustrates response of the platform in heave for regular waves of small amplitude. A summary of the irregular wave data is given in Table B-7.

Assuming a wave period of 9 seconds for both test conditions, the approximate dynamic axial forces are as shown in Table B-8.

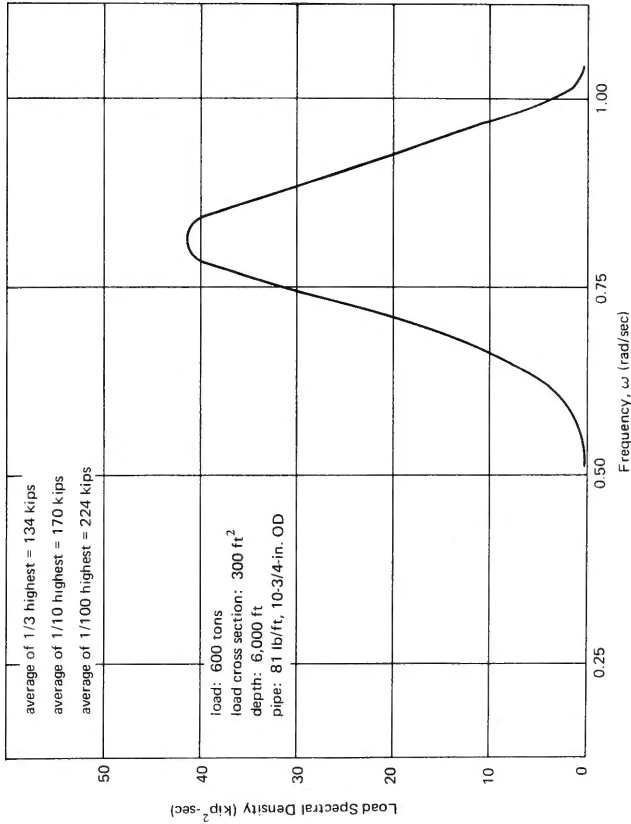

Figure B-15. Dynamic load spectrum for C1-M-AV1 with 20-knot wind and fully developed sea.

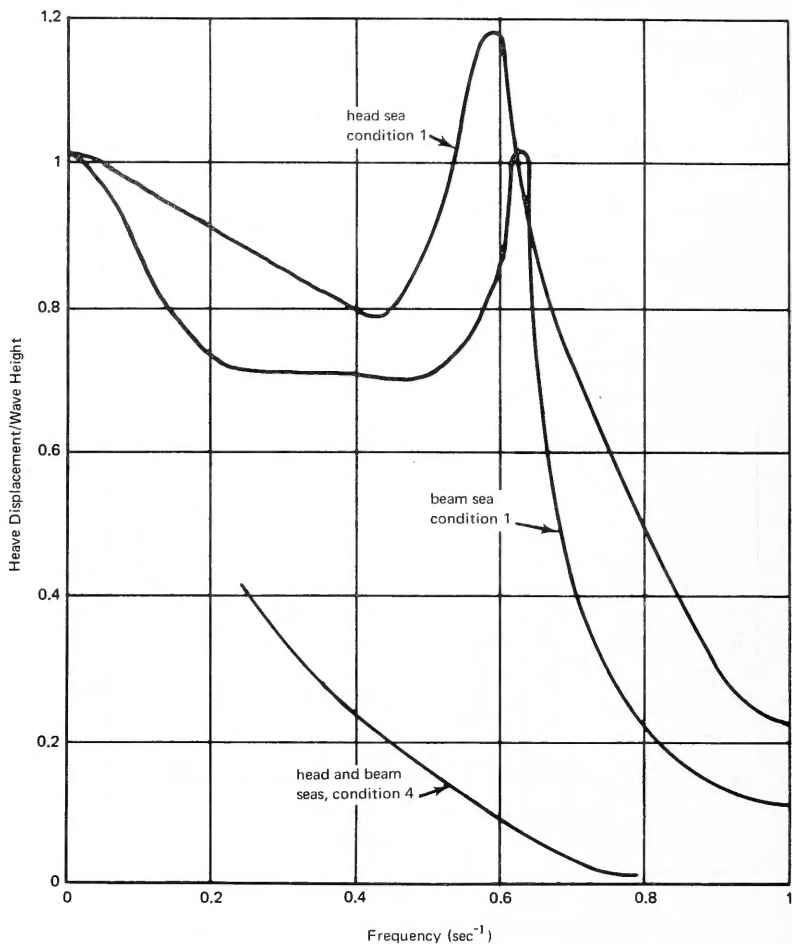

Figure B-16. Heave response of *FORDS* in regular waves of small amplitude.

The axial forces imparted in the string for test condition 1 are particularly significant; they are comparable to what can be expected in a ship of around 13,000 tons displacement. For a ship heading directly into a sea state 6, the dynamic forces are 17% of the static forces; for a sea state 4 the same heading will result in dynamic stress 10% of the static. The latter is more realistic.

Naval Civil Engineering
Laboratory, Port Hueneme,
California

AUTHOR Feasibility Study and
Comparative Analysis of Deep

TITLE Ocean Load Handling
Systems - December 1969

— —

.

1944
JULY
20