

Frank M. Chapman

FOR THE PEOPLE
FOR EDUCATION
FOR SCIENCE

LIBRARY
OF
THE AMERICAN MUSEUM
OF
NATURAL HISTORY

9/

THE FLIGHT OF BIRDS



Eagles soaring. (See Chap. X.)

THE FLIGHT OF BIRDS

BY F. W. HEADLEY, M.B.O.U.

Author of "The Structure and Life of Birds"
"Life and Evolution" &c.

WITH SIXTEEN PLATES
AND MANY TEXT-FIGURES

WITHERBY & CO.
326 HIGH HOLBORN LONDON

1912



Printed by WITHERBY & CO.
at their Printing Press in
Middle Row Place London

95-160 926-310.47

PREFACE.

The flight of birds cannot but be of interest to men who sail the air on their biplanes or monoplanes, for the bird is, as yet at any rate, peerless among aviators, and in describing his methods I have kept in view the methods and the difficulties of those who are striving to rival him. It is possible, therefore, that this little book may find readers among those who not only study flight but fly. But, since I have tried as far as possible to avoid technical terms and make it easily intelligible, I hope it may appeal to the larger class who, whether scientific ornithologists or not, take a delight in birds and their doings.

I have to thank many friends for their help ; Mr. J. A. Tregelles for three drawings which can speak for themselves (the frontispiece and figures 13 and 14) and also for reading a typewritten copy of the book : Mr. C. W. Adams for reading the first five chapters : four Haileyburians past or present for drawings and a photograph ; W. T. Hichens for figures 18-23 ; G. G. Nanson for the diagrams ;

G. H. G. Perry for figure 27 ; A. P. Whitehead for Plate XIV, D. Mr. P. Disney has been kind enough to read the proofs. In addition I have to thank Mr. R. C. Gilson for some valuable criticisms, Mr. F. H. Jeffery for help in some small experiments: Messrs. Duckworth have very kindly allowed me to reproduce several of the illustrations of my *Life and Evolution*. The photographs (with the one exception I have mentioned) are my own. Most of them are now published for the first time, but several have appeared in *British Birds*, and three in the *Journal* of the Aeronautical Society. The Editors of *British Birds* and the Secretary of the Aeronautical Society kindly permit me to use them.

F. W. HEADLEY.

HAILEYBURY,
March, 1912.

CONTENTS.

CHAPTER I.

GLIDING.

PAGE

Resistance of Air—Lift and Drift—Curve of Wings—Area of Supporting Surface	1
---------------------------------------------------------------------------------------	---

CHAPTER II.

STABILITY.

Centre of Gravity—Points that make for Automatic Stability —Voluntary Adjustments	23
----------------------------------------------------------------------------------------------	----

CHAPTER III.

MOTIVE POWER.

Leverage—Propulsion—Phases of the Wing-stroke ..	38
--------------------------------------------------	----

CHAPTER IV.

STARTING.

The Preliminary Jump—Loss of Altitude between Wing- strokes—The Wing's Freedom to Rotate—Aeroplanes —Muscles—Big Birds and Small	48
------------------------------------------------------------------------------------------------------------------------------------------------	----

CHAPTER V.

STEERING.

A Variety of Methods—Good Steerers and Bad	59
--------------------------------------------------	----

CHAPTER VI.

STOPPING AND ALIGHTING	64
--------------------------------	----

CHAPTER VII.

THE MACHINERY OF FLIGHT.

The Breastbone and the Connected Bones—Muscles and Quality of Muscle—The Scaffolding of the Wing—Pneumatic Bones—Stiffness of Wing—Expanse of Bone—The Spreading of the Wing—Structure of a Flight-Feather—Moulting—Legs	67
----------------------------------------------------------------------------------------------------------------------------------------------------------------------------------------------------------------------------------	----

CHAPTER VIII.

VARIETIES OF WING AND OF FLIGHT.

Curve—Narrow and Broad Wings—Styles of Flight—Flight in Flocks—The Whir of Wings	91
------------------------------------------------------------------------------------------	----

CHAPTER IX.

PACE AND LAST.

Experiments and Observations—Wind—Velocity of Migratory Flights—Endurance	103
-----------------------------------------------------------------------------------	-----

CHAPTER X.

WIND AND FLIGHT.

Rising—Flight with the Wind—Undulating Flight without Movement of the Wings—Advance in a Direct Line without Movement of Wing—Advance Sideways in a Direct Line—Soaring—Soaring in a Horizontal Wind Impossible.. .. .	120
------------------------------------------------------------------------------------------------------------------------------------------------------------------------------------------------------------------------	-----

CHAPTER XI.

SOME ACCESSORIES.

Digestion—Circulation, Breathing, Temperature—Repair of the Machine—Call-notes and Song	154
-------------------------------------------------------------------------------------------------	-----

LIST OF PLATES.

I.—Eagles soaring	<i>Frontispiece</i>
	<i>Facing page</i>
II.—Photographs of Pigeons and Gull, showing right and left wings giving different strokes	30
III.—Photographs of—A : Pigeon using tail for maintenance of equilibrium. B : Pigeon gliding. C : Gulls gliding	36
IV., V., and VI.—Photographs of Pigeons showing the phases of the wing-stroke in series ..	40, 42, 45
VII.—Photographs of Gulls flying	46
VIII.—A and B : Photographs of Pigeons starting to fly. C : of Pigeon rising with body steeply inclined. D : of Herring-Gulls starting	49
IX.—Photographs showing different methods of steering—A and B : of Gulls. C and D : of Pigeons	60
X.—A and B : Photographs of Pigeons alighting. C : of Pigeon checking speed	64
XI.—A : Photograph of wing, showing elastic ligament. B : of flight-feathers and tail-feather ..	85
XII.—Drawing by I. C. Maclean (from <i>Life and Evolution</i>), showing minute structure of flight-feather	86
XIII., XIV., XV.—Photographs of different types of wing	91, 92, 94
XVI.—Photographs of Gulls with motionless wings following steamer	136

LIST OF FIGURES IN TEXT.

	<i>Page</i>
1.—Glass balls, an illustration of Sir I. Newton's experiment	3
2.—Diagram illustrating gliding	6
3.—Parallelogram of forces	7
4.—Diagram and drawing of boat tacking	8
5.—Illustrating kite-flying	9
6.—Showing the proportion of resistance to support ..	10
7.—Further illustrating the subject of resistance and support	11
8.—Planes set at different angles to the horizon	12
9.—Showing the advantage of a curved surface	16
10.—Two cubes	19
11.—Showing the disadvantage of an excessive curve ..	25
12.—Showing the shifting of the centre of pressure ..	26
13.—Swift gliding with wings fully extended	35
14.—House-Martin gliding with wings partly flexed ..	35
15.—Showing the velocity with which the extremity of the wing moves	39
16.—Showing how the downstroke propels as well as lifts	42
17.—(After Marey) Gulls flying	43
18.—Breastbones of Guillemot and Falcon	68
19.—Breastbone and connected bones of Adjutant ..	69
20.—Clavicles of Tern and Eagle	70
21.—Humerus of Eagle	71
22.—Humerus of (a) Skua ; (b) Hornbill ; (c) Sea-Eagle. Drawn to scale.. .. .	78
23.—Skeleton of wing of Adjutant	80
24.—(After Alix) showing elastic ligament, anterior wing-membrane, etc	82
25.—Illustrating advance with motionless wings at right angles to the wind	131
26.—Illustrating advance in the teeth of the wind with wings held rigid	136
27.—Gull gliding sideways with wings held rigid ..	140

THE FLIGHT OF BIRDS.

CHAPTER I.

GLIDING.

RESISTANCE OF AIR—LIFT AND DRIFT—CURVE OF WINGS—
AREA OF SUPPORTING SURFACE.

NOT long ago the sight of a sparrow on the wing, or even the sight of a lark rising in air and singing as he rose, excited but little interest or wonder in the mind of the average man. It came natural to birds to fly, and to fly so perfectly that they concealed their art. If they had had difficulty in flying, there would have been matter for astonishment. But why waste any wonder on the easy flight of a lark or a sparrow? Such familiar things were taken for granted and seemed to call for no explanation. As soon, however, as men began to emulate birds—gliding downwards first from some elevated position and, later, by means of powerful engines, rising from the ground—then there was less disposition to take the bird's flight as a matter of course. The bird too, it was felt, had once been a beginner. He too had had difficult problems to solve and had solved them long ago, the very perfection of his methods making it difficult to

understand fully what his methods are. But whatever the difficulty of learning from him, the bird had certainly much to teach. Such a past master in the art of flying must needs be able to give some hints to the man whose ambition it was to discover the ideal design for an aeroplane.

And so the question "How does a bird fly?" became one that had an interest not only for ornithologists. Those who gave it any thought soon found that it involved a number of problems. First comes the question how the yielding air can support a heavy body when gravity is tugging it downwards. Then, of no less practical interest is the question, how the bird maintains his equilibrium, or recovers it if for the moment he happens to lose it. How does he move his wings so that they may at once propel and support him? How does he steer? How is it that the small bird is able to start so easily from the level ground? What of the easier but important problem of alighting without jar? How is it that the bird, big or small, is able to treat with contempt the sudden gusts and eddies that the boldest aviator fears? Does the bird ever gain advantage from the unequal velocity of the wind? Does he search for up-currents and get them to lift him?

Resistance of Air.

The first of these problems was solved by Sir Isaac Newton. By means of an experiment, that may well astonish us if we bear in mind how imperfect were the appliances that he had at his disposal, he demonstrated the peculiar property of

air that makes flight a possibility. The resistance of air to a moving body may be little, may be great. That it may sometimes be considerable many a bicyclist has found out to his cost when he has tried to double and redouble his speed. There comes at last a time when the "yielding air" almost refuses to yield. In fact the resistance it offers to a body moving through it increases as the square of the velocity. Of the ingenious experiment by which Newton proved this I must give a brief account. He took glass globes of equal size but unequal weights, corresponding to the figures 1, 4, 9, 16. These he let fall from the dome of St. Paul's and measured the velocities when they had settled down to a uniform pace. Since there was no gain or loss of velocity, the resistance of the air must have been in each case equal to the weight of the falling globe. But it

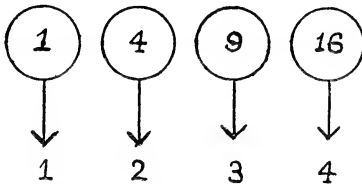

FIG. 1.

turned out that the relative velocities corresponded to the figures 1, 2, 3, 4, whereas the weights of the globes are represented by the squares of these numbers, viz. 1, 4, 9, 16. From this he concluded that the resistance of the air increases as the square of the velocity. Recent experiments have shown that Newton's law is not absolutely accurate. Up

to 10 metres per second (about 22 miles per hour) the increase in resistance is rather less than the square of the velocity, whereas for velocities greater than 10 metres per second the resistance increases at a still more rapid rate.*

But to resist, to give effective support, the air must be in proper condition. If it has just been pounded and battered, it is useless to trust to it. And so perpetual forward movement to ever fresh fields is necessary. A bird cannot mark time in the air. It is true that one often sees a Kestrel Hawk hovering, apparently without any forward motion, his wings, one might imagine, pounding the same air over and over again. But there is good reason to believe that the Kestrel never hovers except when there is a fair breeze to bring fresh unbattered air to his wings. If a long string be tied to a Pigeon's leg, he will fly perfectly well till he reaches the end of his tether. But as soon as he feels the pull of the string he will drop to the ground. When a flock of birds are travelling across the sky, it is easy to see that not one of them puts himself immediately behind any other. Were any individual to do so, he would not have at his disposal the fresh undilapidated columns of air that are essential, and moreover he would feel all the backwash from the bird in front. At least one aviator has lost his life through getting into the wash of an aeroplane that was a little ahead of him. In building a biplane the question of finding air that has not been tumbled is one that cannot be neglected. A writer who appears to speak with authority says

* Marey, *Vol des Oiseaux*, p. 218.

that its two surfaces must have a space of four feet between them, or else they will interfere with one another; one will tumble the other's air. It is true that I have seen a triplane with its "planes" at a distance from one another of three feet only. But whatever the minimum interspace, it must be considerable. And yet when birds are flying low over water they do not ruffle its surface. Pelicans flying over the Nile, not more than a foot from the water, so a good observer says, left the surface undisturbed.* Still, I cannot help thinking that the space between the birds and the water was under-estimated. At any rate a pigeon's first strong wing-strokes when he rises scatter straws, dust, and feathers from the ground where he takes off.

Enough has now been said to show how effective is the support that the air can give to a rapidly-moving body, and how essential it is that the bird or the aeroplane should be unceasingly moving onward to columns of air that are fresh and undisturbed.

Lift and Drift.

It is probable that the power of flight was first attained by terrestrial birds which jumped from tree to tree, their wings aiding them to float through the air. If this floating through the air had been their crowning achievement, they would have done nothing remarkable, for mere gliding is not flight. Since, however, gliding seems to have been their first attainment, just as it has been with human flyers, I shall begin by investigating this comparatively simple performance. At the outset there

* Quoted by Marey, *Vol des Oiseaux*, p. 30.

is a very elementary matter to be made clear. Let us picture the bird to ourselves as gliding in an exactly horizontal direction. The resistance of the air to his forward progress is equivalent to a horizontal wind blowing against him, and what is wanted is support, to counteract the downward pull of gravity. From a horizontal wind he must somehow get this support. The question presents no difficulty to anyone who has studied elementary mechanics, and in the application of mathematical principles the bird is a wonderful proficient. He inclines his aeroplane (his expanded wings and his

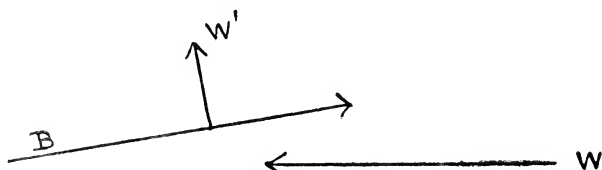

FIG. 2.

body) slightly upward, and the result is that the air supports him more than it resists him. It acts at right angles to the plane that he opposes to it.

In fig. 2, B represents the gliding bird, w the rush of air against his expanded surface. If the air is still, there will, nevertheless, be the wind due to the bird's own velocity. W' , at right angles to the bird, shows the direction in which the wind acts; its lifting power, when the bird inclines himself thus, being greater than its resistance. The action of the air at right angles to a plane moving through it, is illustrated by an experiment sometimes made by very unscientific persons. A stone is thrown

slanting-wise at a window—thrown by a dexterous, mischievous urchin standing far off beneath the wall of the house—and the fragments of glass as they go flying into the room make a right angle with the plane of the window.

The air, then, striking against the plane presented by the bird acts at right angles to it, and there comes into play a resolution of one force into two. This introduces what is known as the parallelogram of forces.

There is a force acting along $A B$ (fig. 3), and if resistance is in this direction it may resolve itself

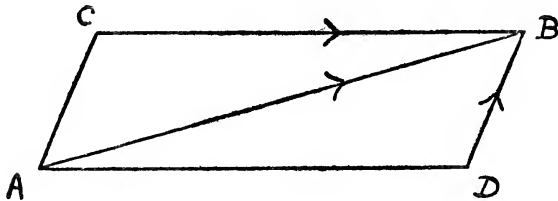

FIG. 3.

into two forces represented in magnitude and direction by the lines $C B$, $D B$. Take the case of a boat tacking. The wind acts at right angles to the sail, but the boat refuses to move much in that direction (i.e. broadside on); she makes only a little leeway. The force of the wind, therefore, acting towards x (fig. 4), is broken up into two forces acting towards D and L , and that towards L , as I have said, does not count for much, since the boat will not readily move broadside on. So there is much headway and a little leeway. The principle at work is the same when a bird is gliding horizontally. His body is inclined slightly upward. The force of the air acts

at right angles to the surface he presents to it. And this force is broken up into two, the one supporting him, the other tending to drive him backward, or, as it is now briefly and clearly put, the force is resolved into lift and drift.

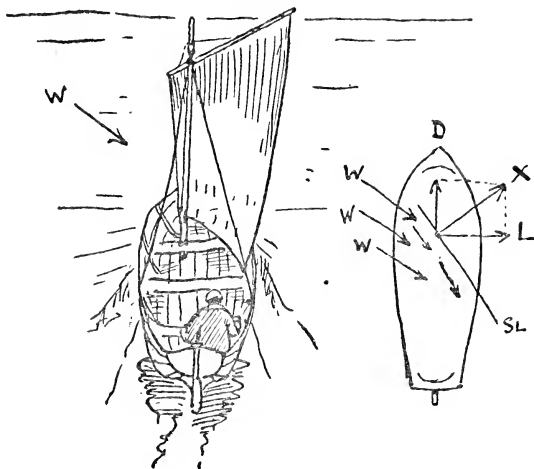

FIG. 4.

Boat tacking.— w , the wind which acts at right angles to SL (the sail), towards X . The force is broken up into two forces, acting towards D and L .

A paper kite supplies us with another and perhaps still more apt illustration. If the air is still, the kite-flyer may supply a force by running with the string; if there is a wind, he has merely to hold the string. Let us imagine that the wind is blowing horizontally. It will, nevertheless, lift the kite, as long as the string is held firmly. It strikes against the oblique surface which the kite presents, and

acts at right angles to it. Drift is prevented by the firmly-held string, and lift is the sole result (fig. 5).

It is only when there is resistance that there is any force to be thus resolved into two. If the string breaks, gravity at once begins to pull the kite to the ground.

We have now a further question to investigate and, to simplify it, we must consider not the gliding bird, but a flat plane set at a slight upward incline and driven horizontally through the air. A flat plane, having none of the curves and concavities of the bird's wing, is far inferior for purposes of flight, but its simplicity recommends it when the

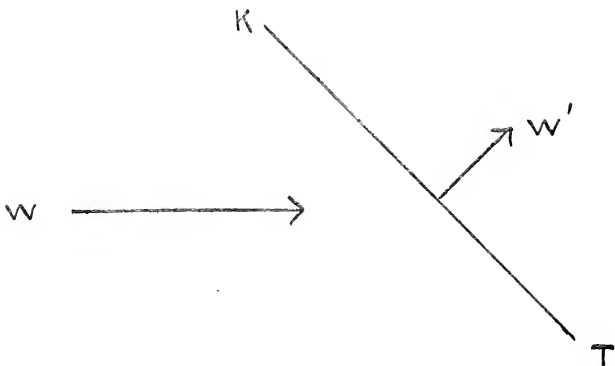

FIG. 5.

TO ILLUSTRATE KITE-FLYING.

w , horizontal wind blowing against kite, $K T$. w' (at right angles to $K T$), line along which the force of the wind acts.

object is to explain elementary principles. Set at an incline and moving horizontally it will tend to rise. The resistance of the air is equivalent to a wind blowing against it. The wind would act in

a direction at right angles to the plane, and the force so acting is, of course, resolved into two, one tending to raise the plane, the other resisting its horizontal progress. The question, then, which we wish to decide is : In what proportion is the force of the wind divided between the two components, between lift and drift? Now, supposing that BD (fig. 6) represents the plane set with an upward incline and driven horizontally through the air, it can be shown that line DC represents the resistance of the

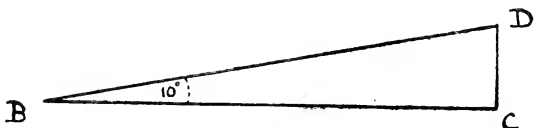

FIG. 6.

air to its onward progress and BC , a much longer line, the support given by the air. In fact, when the plane is inclined but slightly upward the support it gets from the air is far greater than the resistance, a fact that can be proved by experiment. The mathematical proof that DC represents the drift (or resistance), and BC the lift, I give in fig. 7.

It is now apparent that, as the angle of inclination to the horizon is more and more reduced, the proportion of lift to drift becomes greater and greater. Why not, then, reduce the angle till the resistance of the air to horizontal progress becomes a negligible quantity? But obviously there is a limit to the process. If the plane has so slight an incline that it is almost horizontal, the air will offer but little resistance, and however big a proportion of this we may allot to lift and however small a one

to drift, yet the actual amount of lift will be but small. If the strongest man among the survivors

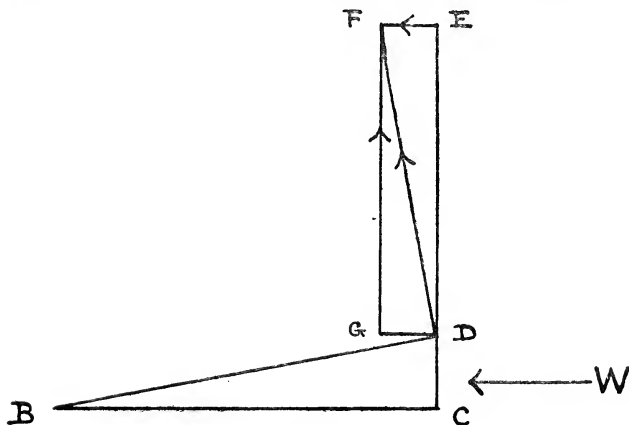

FIG. 7.

BD is the plane, w the wind blowing horizontally against it. BC is the cosine of the angle at B , DC the sine of the angle. Produce CD to E , making $DE = BC$. From D draw DF at right angles to BD . From E draw EF at right angles to DE . (This decides the length of the line DF). Draw FG parallel to ED and DG parallel to FE . Let DF represent the force of the wind acting at right angles to BD . It can be resolved into two forces, FE and $FG (=ED)$. ED we know $= BC$, and it can be shown that $FE = DC$.

In the triangles DEF , BCD , $BC = DE$, and the angles at E and C are each right angles. If we could prove a second angle $=$ a second angle, the triangles would be equal in every respect. Now the angles at D together $=$ two right angles, and the angle $BD F$ is a right angle. Therefore $BD C$ with FDE makes one right angle. But $D F E$ with $F D E$ makes one right angle. Therefore angle $D F E =$ angle $B D C$. The triangles then are equal, and the two sides FE and $DE =$ respectively DC and BC . But FE represents drift and DE lift. Therefore DC , the sine of the angle at B , represents the drift, while BC , the cosine, represents the lift.

of a starving ship's crew is able to take for himself nineteen-twentieths of the last biscuit, nevertheless he gets but a poor meal; and it is obvious that if

the plane were not inclined at all, but presented its edge to the air, there would be practically no support. There is, therefore, beyond all dispute a limit somewhere to the possible reduction in the incline of the aeroplane. The question is where, for practical purposes, that limit comes in. Newton formulated a law with regard to this, a law which is now quoted only to be condemned, and sometimes quoted with expressions of contempt for him and mathematicians in general.* Newton held that the resistance of the air increases as the square of the sine of the angle of inclination.

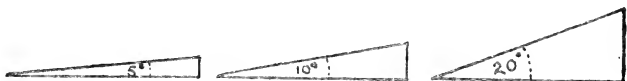

FIG. 8.

Thus, if we take angles of 5° , 10° , 20° , the resistance would increase, from 25 to 100, to 400. Instead of being grateful to Newton for his great contribution to our understanding of flight, his discovery that the resistance of the air increases as the square of the velocity of bodies moving through it, some writers have depreciated him and his work because he has come to a wrong conclusion on this further question. As a matter of fact the resistance of the air varies as the angle, i.e. as its sine, not as the square of its sine. Therefore, as you diminish the angle, you still have a considerable amount of resistance, and it is divided up largely in favour

* See Sir H. Maxim's *Artificial and Natural Flight*, pp. 2-6. The question is well dealt with in Prof. Langley's *Experiments in Aero-dynamics*; see especially pp. 24 and 25.

of support, of lift as opposed to drift. If Newton's law held good, if the angle of inclination were more and more reduced till it amounted only to, say, 5° , then the resistance offered by the air would be too small to be worth dividing up between lift and drift. Even the lion's share would be worth next to nothing. But experiment shows that an aeroplane set at an angle of 5° can, if it travels fast, find support in the air.

But, although as we reduce the angle of inclination the resistance of the air does not diminish at the rapid rate that Newton imagined, nevertheless there must obviously be a point beyond which the fining down of the angle cannot go, since the air will at last cease to give the required support. But before we reach the lowest possible limit another factor comes in which checks us as we are making successive reductions. As we continue to cut down the angle there comes at last a point at which the question of friction obtrudes itself in very unpleasant fashion. Imagine the aeroplane driven through the air at a very minute angle. If it is to find support, it must travel at a very great pace, else the resistance of the air will be too small. With every diminution of the angle there must be an increase of pace, and it might be thought that, if only the pace were increased sufficiently to make up for the diminution of the angle, all would go well. Professor Langley made some most valuable experiments which showed the great advantage of a small angle of inclination, and, emboldened by this great and important discovery, he proceeded to frame a formula and to speak

of a law. By experiment he had discovered an indubitable principle, but subsequent experiments have discovered an equally indubitable fact, which at a certain point interferes with its operation. The angle cannot be reduced below, approximately, 5° without bad results. At a less angle, with the necessary increase of pace, the friction of the plane against the air increases so rapidly that, so far from there being any gain from the further reduction of the inclination, there is an actual loss.*

On this subject a writer in *Flight* has some very interesting calculations, founded partly, it is true, on theory, and requiring further verification by experiment, but probably representing the facts without any considerable deviation.† Indeed experiment has already proved his main thesis, so that it is only detail that requires further testing. He imagines aeroplanes having the ideal camber or curve for their planes, a large curve if they are to travel slowly at a great angle of inclination, a slight curve if they are to travel fast. They are to carry a weight of 100 lb. Let us imagine them driven by 3 horse-power at the angles 30° , 25° , 20° , 15° , 10° , 5° . The velocity will increase rapidly as the angle is reduced. At 30° it will be 38 miles per hour. With the successive reductions of the angle it will increase to 47, 60, 78, 106, 134. The pace at 5° and even at 10° is greater than most people would wish to travel at, so the power applied might with advantage be reduced. Two horse-power at 10°

* See *The Aero Manual*, p. 21; *Flight*, July 9, 1910; and Langley's *Aero-dynamics*, p. 37.

† *Loc. cit.*

and 5° respectively would mean 70 and 90 miles per hour. Even 1 horse-power, with an angle of 5° gives a velocity of 43; in other words, 1 horse-power, if the plane is set at an angle of 5° , is more effective than 3 horse-power when the angle is 30° . In fact, if you have a good aeroplane and the skill to use it well, you require less power to fly fast than to fly slow. But if you reduce the angle of inclination below 5° you find that the tables are turned upon you. So far from economising power, you would have to use it in lavish style, to overcome friction.

Curve of Wings.

We must now turn to the question of curves. The curved surface is undoubtedly superior to the flat. A toy paper glider, being a mere feather-weight, can dispense with curves, but without curved surfaces—cleverly designed ones too—aviation would be out of the question. An aeroplane presents concave surfaces to the air; its “planes” curve from front to back, and a bird’s wings have concavities that are probably better adapted for flight than anything that human ingenuity has designed. On this subject even an umbrella can tell us something. When its ample concavity is turned towards the wind its efficiency in catching and holding the air is so great that it speedily becomes a wreck of wires. Lilienthal, a distinguished flight pioneer, whose experiments in gliding did much to make aviation practicable, fully appreciated the value of the curved surface. Sometimes when he was carrying his glider to a little

hillock, his jumping-off place, outside Berlin, he was cheered and emboldened by the way the wind would catch his glider's well-designed concavities and nearly lift him from the ground. When he reached his little hillock he would jump from it and make glides of 150 yards and more.

Lilienthal found that the air that met his glider's concave surface did not act at right angles to the chord of the arc (fig. 9), along F , but along a line occupying somewhat the position of F' .

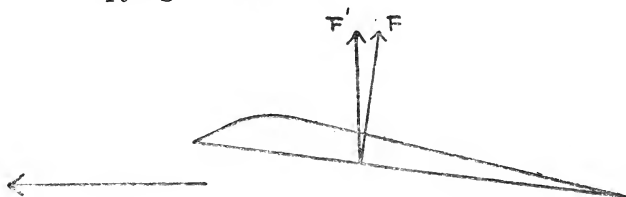

FIG. 9.

The arrow shows the direction in which the glider is travelling.

Experiments made by Mr. Wilbur Wright and his brother have shown that Lilienthal had called attention to a principle on which the aviator can base his calculations. In short, with a properly rounded surface the lift is greater and the drift is less than with a flat one. In order to obtain the maximum gain, the best possible curve must be discovered, and this can only be done by experiment. The writer in *Flight* already quoted is of opinion that each velocity has its appropriate curve. An aeroplane that is to be a racer should, he maintains, have its surfaces much less curved than a slowly-flying one, and undoubtedly the wings of birds suggest that he has enunciated a true principle.

Very fast flyers, such as the Swift, have very little concavity. There is another fact, too, that points to the same conclusion: in a bird's wing the part that is near the body is the most concave, while towards the extremity it becomes nearly flat, in some cases quite flat. Now the extremity of the wing, when a stroke is given, moves with great velocity forward as well as downward, the near part comparatively slowly. Thus birds seem to be exponents of the principle that the curve should vary inversely as the speed. And here I must point out a great advantage the bird has over his upstart rival, the aeroplane. The aeroplane is rigid, with at most the rear edge only of its plane flexible. If the principle to which I have called attention is sound, it must be built either with a curve appropriate to great speed or with one which suits comparatively slow travelling. It cannot be varied during flight according as the pace is varied. But when the bird takes a very hard stroke, the front-to-back curve of his wings, which is mainly the curve of the feathers, is much reduced, so that by plying his wings with great vigour he to some extent modifies his configuration and adapts it to his high velocity. (For birds in rapid flight, *see* Pls. IV-VII.)

It is always well to ask "Why is it so?" whenever experiment discovers a fact. Why, then, with a curved surface is the lift more and the drift less? It is very difficult to see how the air does its work, and theory on such a subject may prove to be only random guesswork. But the lift would seem to be greater from the simple fact that the

air cannot so easily escape. When the moving surface is a plane, the air is unconfined and the force is dissipated. The reduction of the drift (i.e. of the resistance to the forward movement of the surface) may be illustrated by the passage of a boat, built on good lines, through the water. The resistance of the water to the bow is balanced, or nearly so, by the shove given to the stern by the water closing behind it, so that there is little, except friction, to retard the boat. In the same way the air closes upon the hinder part of the curved surfaces of an aeroplane ; there is no region of " dead air " behind it. The matter is well explained in a little book on *Model Flying Machines* (pp. 19 and 20) by Mr. W. G. Aston. There is a region of " dead air " behind a flat surface when it is given an upward incline and is driven forward horizontally. The amount of " dead air " is the measure of the amount of resistance.

Area of Supporting Surface.

We can hardly leave the subject of gliding without touching on this important question : What area of supporting surface is required for, say, one pound weight ? Obviously no hard and fast rule can be laid down. Since it is the front part of the plane on which the wind mainly impinges, the back part is of less importance ; indeed it may be quite superfluous, a useless encumbrance, if the breadth from front to back is excessive. Besides this, as I shall show, we cannot frame a formula that will apply equally to big aeroplanes and small, to the big bird and the small bird. The *Aero Manual*

says, "Nearly one square foot for each pound weight." But it has in view big machines only. When we go to the various creatures that fly, weigh them and measure their surfaces, we get most diverse results. The big flyers, we find, have small wings, the small flyers big ones, if difference in weight is allowed for. Compared with a gnat or a butterfly a Stork has a very small supporting surface, a small one even when he is compared with a Swallow. When M. de Lucy discovered these facts and published them the astonishment was great. Here are some of his figures :—

			Surface per 1lb. weight.		
			sq. yds.	ft.	ins.
Gnat 4	6	105
Butterfly 3	8	87
Swallow 0	4	18
Pigeon 0	1	14
Stork 0	0	122*

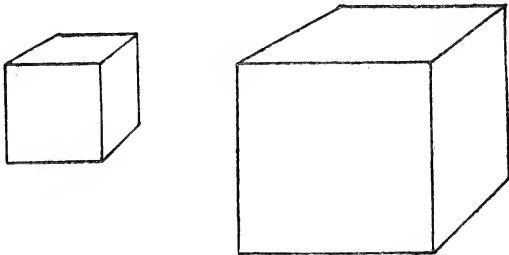

FIG. 10.

But before long mathematicians hit upon a plan by which they were able (or thought they were able) to rob the figures of their startling character, and

* See Marey, *Animal Mechanism*, p. 222, and Pettigrew, *Animal Locomotion*, p. 133.

put big and small birds in this respect more or less on a level. They appealed to the elementary principles of geometry. If you take two cubes, a side of one of which is twice the length of the other, the larger one is in bulk eight times as great as the smaller one, but its surface area is only four times as great. This holds true of other figures of three dimensions that are not cubes. Magnify a bird till it is eight times its former bulk and you will only have multiplied its surface area by four. In order, then, to compare bird with bird correctly, you should take (so say these theorists), the cube root of its weight (for the weight is practically the bulk, i.e. three dimensions multiplied together) and the square root of its surface area (since that is two dimensions multiplied together). When we adopt this method we find the preponderance of the small bird in point of wing-area per pound weight not so very great. And we may, if we are so constituted, derive a certain comfort from feeling that we are following out geometrical principles. But these principles have, it must be owned, in the case of some species been widely departed from. What are we to make of the legs and neck of the Flamingo? If any small bird of ordinary build were symmetrically enlarged, should we ever arrive at elongations so enormous? It is, of course, true that if the bulk of a small bird were multiplied many times, and the area (not the bulk) of his wings increased in proportion, he would have a greater expanse of wing than his muscles could possibly work. If the Stork had a wing-area as great in proportion to his weight as the Swallow, then

(taking his weight as four pounds and four-fifths) his wings would together measure twenty square feet! This would be a monstrous acreage of wing to raise and lower. But when we have pronounced it monstrous, we have still to answer the question why it is that the big flyer requires, in proportion to his weight, a comparatively very small supporting surface?

Let us imagine the Swallow supplied with wing-area at no more liberal rate per pound weight than that at which the Stork is supplied. Then, taking the Swallow's weight to be about five-sevenths of an ounce, he would have five square inches of wing-surface—two and a half on either side—a miserably poor allowance. A wing so small would be largely made up of margin, and the air would escape at the edges. The gnat has over four and a half square yards of wing for one pound weight. His actual allowance for his almost imponderable insignificance is considerable, but if we make provision for him at the rate at which the Stork is supplied, his wing-surface becomes a mere point, "without parts and without magnitude," to quote Euclid's familiar definition. The air would offer no resistance to so near an approximation to the theoretical point. Here, no doubt, we are getting at the main fact that explains the comparatively small size (when weight is allowed for) of the wings of the great flyers. Since the wing-surface is much larger *absolutely* the air does not escape so easily at the margins; each square inch is more effective, since there is less waste. Later on I shall make a further comparison of big birds and small, but

one important difference and its explanation have, I hope, been made clear (*see* Chap. iv).

It will be more convenient to consider the question of upward and downward gliding in the next chapter.

CHAPTER II.

STABILITY.

CENTRE OF GRAVITY—POINTS THAT MAKE FOR AUTOMATIC STABILITY—VOLUNTARY ADJUSTMENTS.

There are two things that we must carefully distinguish—stability and the maintenance of equilibrium. An aeroplane, when it has once completely lost its balance, cannot recover it, though some swaying or pitching can, no doubt, be corrected. The stability of a bird is a very different thing from the aviator's careful maintenance of equilibrium. A very strong and sudden gust may throw the bird on his side, or even on his back, and yet he will very quickly right himself.

Centre of Gravity.

But we want to know whether a bird in ordinary flight, when there are no very sudden gusts, is automatically stable, or whether he has to be perpetually making small adjustments. It is sometimes maintained that a bird need take no trouble about the question of balance, since his centre of gravity is low down. The great flight muscles, which are massed upon the breast, form a great part of his weight. I have weighed the three pairs of breast muscles of two Wood-Pigeons and those of two

domestic Pigeons, and found that they account for about one-fifth, or even more than one-fifth, of the weight of the whole bird. Indeed, in one Wood-Pigeon they were equal to three thirteenths of the total weight—a little less than a quarter.* Hence the centre of gravity lies considerably below, though not so very far below, the shoulder joints. But the idea that it is good to have the centre of gravity of a flying machine low down is altogether a misconception, a fact that can easily be put beyond all doubt by experiments with small gliders. Weight, placed low, tends to make the machine oscillate and even swing right round. It is best that it should be on a level with the supporting surface. In the case of the bird, the chief supporting surfaces, the wings, are always changing their relative position as they are raised or lowered, and, of course, as they move they to some extent raise or lower the centre of gravity. This must make voluntary adjustments for the purpose of recovering balance still more necessary. But Professor Marey has pointed out a curious fact which may make these oscillations less difficult for the bird to deal with. When the down-stroke takes place and the wings are lowered, the centre of gravity occupies a lower position in the bird, but the bird as a whole, except during very rapid flight, rises. With the up-stroke, on the other hand, there is a raising of the centre of gravity, but a lowering of the bird ; hence, though the bird's

* Legal and Reichel, in the *Jahresberichte der Schlesischen Gesellschaft* (1879), give $\frac{1}{3} \cdot \frac{1}{4} \cdot \frac{1}{3}$ ($= \frac{1}{3} \frac{0}{4} \frac{0}{3} =$ more nearly $\frac{1}{3}$ than $\frac{1}{4}$) as the proportion of the total weight of the pigeon accounted for by the three pairs of breast muscles. But this would seem to be a mistake: *Charadrius*, according to them, comes next with $\frac{2}{3}$.

body rises and falls, its centre of gravity travels onward almost in a straight line.*

Points that make for Automatic Stability.

Though the position of the centre of gravity is of no avail, the general build of the bird and the elasticity of the feathers make for automatic stability. To begin with, there is the question of curves. I have already pointed out that a curved surface gives more lift and less drift than a flat one. But anyone who experiments with gliders soon finds out that an excessive curve is fatal to stability. In the preface to the *Aero Manual* (1910) it is stated that the curve (the depth of the concavity) should not be more than one-twelfth of the breadth. Imagine a surface with a more considerable curve. The wind



FIG. 11.

Diagram to show the disadvantage of an excessive curve.

will impinge upon its upper side and the glider will duck and descend rapidly to earth. But if the curve is only slight, though the tendency to duck and dive may, no doubt, arise, yet it tends to correct itself. Imagine the glider launched on its way and developing a tendency to lower its head and raise its tail unduly. In proportion as the tendency develops, in

* There is no need to discuss the question of pendulum stability. It is possible to suspend a heavy weight from an aeroplane, and there are theorists who hold that automatic stability may be thus attained. It is obvious that in the case of a bird nothing of the nature of a pendulum is possible. See *Flight*, Feb. 25, March 18, and March 25, 1911.

proportion as the glider makes a smaller and smaller angle with the horizon, the point at which the air acts will be progressively nearer to the front margin, and this will obviously tend to prevent a dive downward.



FIG. 12

Diagrams showing the shifting of the centre of pressure.

This point requires some explanation. Take as an illustration a sailing boat when it is tacking. When it sails close to the wind, the air which strikes against the forepart of the sail is deflected from its course, and rushing towards the stern of the boat forms a buffer which shields the rest of the sail from the air, which would otherwise have impinged upon it. The drawing of a boat tacking, on page 8, and the accompanying diagram, will make this clear. The principle is called the law of Avanzini. The smaller the angle made by the wind with the sail, the nearer the point of impact approaches to the front edge. This is true no less of the slightly curved surfaces of aeroplanes. As the angle of incline to the horizontal is more and more reduced, the wind acts at a point closer and closer to the front edge, and thus the aeroplane may, possibly, correct the dangerous tendency automatically, without the aviator having to make readjustments.

To illustrate this principle I have made experiments with a catapult which, working within runners, threw pieces of cardboard horizontally,

the cardboard being set so as to have an upward incline ; in fact as an aeroplane is set when it is travelling horizontally. This was managed by means of small wire carriers having various inclines, on which the cardboard rested, and which were themselves thrown with the cardboard. So far from pitching head downwards, the cardboard missiles would, even when the angle of deflection from the horizon was small, rise in the air, and sometimes even turn over backwards, so strong was the action of the air on the front margin.

In the bird's wing there is a further automatic safeguard. It curves downwards at the back, at any rate that part of it that is nearer to the body. The wind acting over-strongly upon the downward-curving back part of the wing might, if the whole wing-surface were rigid, capsize the bird and send him diving head-foremost downward. But the elasticity of the feathers prevents an excessive lift. They yield to pressure, and the reduction of their curvature relieves the wing of any excess of pressure on its hinder part.

The same principle holds good with regard to lateral stability. If a strong gust or eddy of air strikes the right wing while the left is struck with less violence, the feathers of the right wing yield to the rush of air and bend upward, so that the very force of the gust to some extent reduces its effect. Such elasticity would seem to be impossible in the case of an aeroplane without dangerously reducing its strength. And yet an aeroplane, from its enormous breadth, is far more liable than a bird to suffer from gusts falling with unequal force on its

two extremities. At present the aviator is at a great disadvantage as compared with a bird. The great expanse of his planes is in itself a danger, and his machine has less power of automatic adjustment. Moreover, the most experienced pilot is a mere novice compared with a bird that has flown many times every day since he left the nest. Still, birds as flyers have already reached their zenith; for aviators greater things are still possible.

Leaving the possibilities or impossibilities of the future, I must return to the bird as he is, and call attention to another point which promotes stability. The extremities of the wings of the best flyers have very little downward curve. If they are travelling very fast through the air, the primary wing-feathers may even bend slightly upwards, and aviators have found that the upward incline of their "planes" reduces the amount of rolling. Thus inclined they give less support than if curved downwards at the extremities, but the very fact that the air is allowed to escape easily to right and left is favourable to equilibrium. If an attempt is made by bending the extremities downward to check its escape, to coop it up, it may make a sudden rush from the right or from the left concavity and cause risk of a capsize. The wing, amply concave as it is till it begins to taper, and shallowing as it tapers, keeps in view the questions of lift and equilibrium; it holds the air, yet provides for its escape. Sometimes when a bird wishes to glide downward he will point his wings steeply upward—a method often adopted by pigeons—much more steeply than the right and left surfaces

of a monoplane. This attitude must tend to ensure a comfortable equilibrium (Pl. III, B).

The question of the escape of air from beneath the curved surfaces seems to be of the utmost importance. Mr. Pilcher's celebrated glider was punctured with many small holes which were intended to encourage a steady escape instead of a sudden upsetting rush on one side. I cannot judge whether this was a good plan for dealing with the difficulty. At any rate, the wing of even a large bird presents too small a surface to be treated in this way. But it is probable that the notches between the feathers at the wing's posterior margin tend to prevent irregular escapes of air from below. The great soaring birds, whose steadiness as they circle with motionless wings is so marvellous, have the great flight-feathers parted like outspread fingers. Moreover, the force of the wind sometimes bends them conspicuously upward, thus giving them an incline that is recognized as favourable to equilibrium.

Voluntary Adjustments.

It cannot be gainsaid that there is much in the bird's build that makes for automatic stability. Nevertheless, since the wind, at low levels at any rate, is a chartered libertine, full of capricious unexpected eddies, such automatic adjustments are altogether inadequate. The bird must be ready at a moment's notice to give his mind to the question of balance, and make conscious voluntary adjustments. But even we ourselves find that movements we are perpetually making tend, through force of habit, to become automatic, and that in some cases

we are not conscious of any difference between the voluntary and the involuntary. In the case of a bird the line is still harder to draw, not only because we cannot get within his mind, but because the movements which we are bound to label voluntary, since they cannot be mere unconscious reflexes, are so largely instinctive. When the young Swallow takes the first plunge from the parental nest and trusts himself to the air, he finds at once that he can fly ; the power of flight is instinctive. A child has to learn by much practice to co-ordinate his muscles ; no other young creature is so devoid of instinctive skill. The young Swallow, though he can co-ordinate his muscular activities well enough to fly with some success, has, of course, much to learn. At the outset he misses most of the flies and gnats, and his parents have to come alongside and put their captures in his mouth. But he seems by instinct to spread his tail when it should be spread, and, no doubt, though it is hard to see this, he takes a harder stroke with one wing than the other, when a harder stroke is required. For fore-and-aft balance he depends largely on his tail. He has not a long neck that he can bend or straighten out, and his legs are so short and light that no movement of them can have much effect. For lateral stability he must, as far as voluntary adjustments are needed, depend mainly on unequal wing-strokes.* That birds do take unequal strokes has been clearly proved by the camera in the case of Pigeons, Owls, Gannets and some others (*see* Pl. II). This inequality, sometimes so conspicuous in a photograph, the human eye has

* *See* Chap. V.

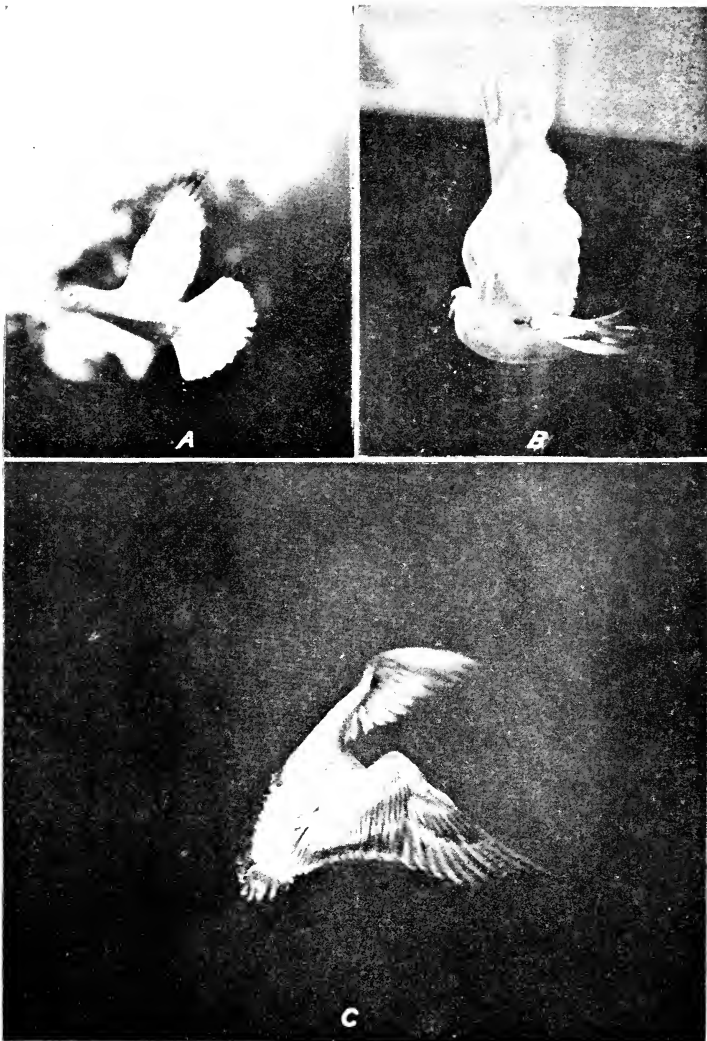

Right and left wings giving different strokes. A and B: Pigeons. C: Young Gull: the right wing only is flexed at the wrist. (See Chap. II.)

great difficulty in detecting, and but for the camera we should have had to own that, though the bird could hardly dispense with this method of balancing and steering, we could get no absolutely conclusive optical evidence. For fore-and-aft balance the means employed vary very much according to the build of the particular bird. Long-necked birds can move their centre of gravity forward and backward by extending or bending their necks. Ducks and Geese usually carry theirs stretched out, Herons habitually make a crook in theirs. Long necks are usually correlated with long legs, and long legs are no less serviceable in the matter of balance. This is shown by the fact that the long-legged have usually small, short tails, the long legs to some extent taking the place of the tail as balancers. A Flamingo, to take a conspicuous example, having legs of enormous length and a neck to match, has no need of much tail to regulate his fore-and-aft balance. A very little extension or retraction of legs or neck will set matters right if they are going wrong. But not only do long legs make a great expanse of tail unnecessary for balancing purposes, they must inevitably hamper its movements if it is to be pulled downward with a view to checking speed or steering to right or left. It may well be that this necessary inefficiency of tail is in part the cause of the comparatively clumsy steering of these big, heavy-legged birds.

It can be shown, too, that for purposes of balance webbed feet very probably play a part of some importance. Not only are they fairly heavy, but they can be used as the tail is used, though not so

effectively. The following table brings out very clearly the poverty of the long-legged and the web-footed in point of tail. I give first the actual length of tail, then the approximate weight of the bird. In two cases I have had to take the weight from a learned paper by two German ornithologists, and I suspect that their hen Sparrow-Hawk was far from plump. Lastly I have given the length of tail which each of the birds has for one pound of its weight. The results are very striking. Were I able to give the area of the tails, they would be much

Bird.	Length of tail.	Weight of bird.	Length of tail for each lb. weight of bird.	Notes.
Sparrow-Hawk (hen)	Ins. 8	5·3 oz. (Legal & Reichel)*	Ins. 24·1	Tail very broad.
Sparrow-Hawk(cock)	6·5	5·2 oz.	20	—
Lapwing	4·1	6·7 oz. (Legal & Reichel)*	9·8	—
Wood-Pigeon ..	6	1 lb. 4·25 oz.	4·7	Tail very broad.
Common Wild-Duck	4·75	1 lb. 15·7 oz.	2·3	Tail pointed, small in area, weak.
Common Heron	6·5	3 lb. 0·6 oz.	2·1	—
Curlew	4·62	2 lb 4 oz.	2·05	—

* *Jahresbericht der Schlesischen Gesellschaft, 1879.*

more so. But the area varies so much, according as they are expanded or not, that I have found it very difficult to give measurements. However, we can bear in mind that the tail of the Sparrow-Hawk, for example, is not only very long but very broad, whereas the tail of the Duck is not only short, but narrow and weak, its inefficiency being even more marked than its small size.

It is noteworthy that the bird which stands at the head of the list as being remarkable for size of tail is not a particularly short-legged bird. Two cock Sparrow-Hawks, of which I took measurements, had each legs 7 inches long (the toes being included). However, the legs are very thin, as if not intended for standing, but, armed as they are with long, efficient claws, for seizing a victim. It is often maintained that Hawks hang their legs down during flight, but this is certainly not usually the case. However, they could on occasion be lowered, to give the tail freer play, without much affecting the bird's equilibrium.

The main function of the tail is to prevent loss of equilibrium, and when large it plays its part wonderfully well. In spite of its great expanse, its weight is a negligible quantity and its working is splendidly prompt. Evolution has done wonders in thus metamorphosing the long, heavy tail of the bird's reptilian ancestor. A number of vertebrae have been compressed to form the pygostyle, the small bony base of this wonderful piece of machinery. What weight there is is almost all accounted for by this little bone and the muscles that move the large spread of feathers. The muscles have the

tail completely under command. At a moment's notice they spread it, make it concave, lower it or raise it, lower this side or that. If the tail is spread and lowered, at once the hinder part of the body is lifted (*see* Pls. III and IX). The opposite effect will follow from the raising of the tail, so that it may catch the wind but little. If a Lark be watched through a field-glass as he rises facing a fair breeze, he will be seen to be perpetually busy with the work of correcting his fore-and-aft balance; and it is to his tail that he trusts. A Chaffinch, perched on a rail with a fairly high wind blowing in his face, keeps his tail perpetually at work. The tail is, in fact, a fine balancer, even more important in this capacity than it is as a rudder. Were it not for the perfection of this balancer, a small bird could hardly land without danger to his eyes in the *chevaux de frise* of a furze bush.

There are other balancing movements still to be considered. From our present point of view, the way the wings are held is of great importance. I have already pointed out that when a boat is tacking (*see* fig. 4, p. 8) it is the front part of the sail that does most of the work, and that similarly when the gliding bird inclines his wings at a small angle to the horizon, it is the front margin that gives him most support. If, then, he holds his wings fully expanded, so as to have as wide-stretching a front as possible, not only will the lift be greater but the centre of pressure (the point at which we may consider the force of the wind as being, so to speak, focussed) will move forward, and this will tend to give the bird's body an upward incline.

And so, if he wishes to maintain his level or rise, he must extend his wings to the utmost; if, on the other hand, he wishes to descend rapidly, a partial flexing is the measure to adopt. To the aviator such a method is only to a very limited

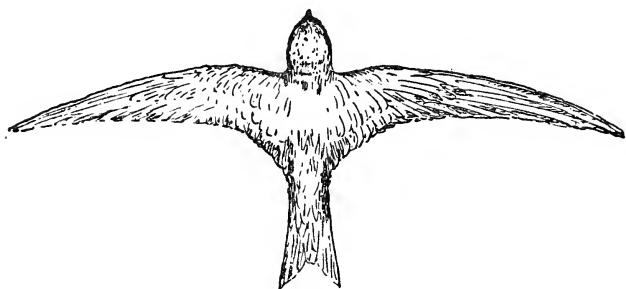

FIG. 13.

Swift, gliding with wings fully expanded.

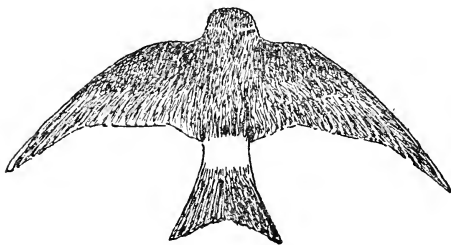

FIG. 14.

House-Martin, gliding with wings partly flexed.

extent possible; he cannot half-flex his planes. Nevertheless, he is able to slide down a steep incline, much as a bird does. By means of his fore-and-aft balancing apparatus, he sets his aeroplane at the proper angle and shuts off steam. If he is

a skilled and experienced pilot, he is, apparently, as steady as he rushes down towards the earth as a bird could be. But, if he did lose his balance, it would be fatal, whereas to the bird a momentary loss of equilibrium is of no consequence.

Leaving aviators and their splendid achievements, I must describe another attitude sometimes adopted by a bird in gliding downward. He will extend his wings to the full, but hold them slanting upward (*see* Pl. III). Obviously in this position the wings give less support, and so he descends. But he descends slowly, not with the rush that is characteristic of the head-foremost downward glide. The wings do not travel edgeways through the air and so they check his pace. Their upward slant is, as I have before remarked, advantageous to balance.

I must now conclude this brief investigation of the bird's stability when on the wing. What we see in the flight of birds—I am not now speaking of soaring—is not a steady, careful maintenance of equilibrium, but an instantaneous recovery of balance whenever it is lost. The bird can afford to be indifferent to the difficult problems which this subject presents. He has something much better than the power of maintaining equilibrium. However the gusts and vagaries of the wind may upset him, he can right himself at once. He owes his wonderful stability to some extent to his fine build and the elasticity of his feathers, but mainly to manœuvres and adjustments that cannot be mere reflexes. The flying machine which he pilots is admirably built: still it can never dispense with a pilot. But his voluntary adjustments are largely



A : Pigeon using tail for maintenance of equilibrium. (See Chap. II. and Plates IV., V., VI. and IX.). B : Pigeon gliding. C : Gulls gliding : (See Chap. II. and Chap. III.)

instinctive, and even the niceties of adjustment that he has to learn must become through habit almost automatic. And the result of it all—of his fine build, his instinct, and his art—is the perfect stability of the machine ; a thing to make the most skilful aviator envious : for who ever heard of a bird losing his balance and falling to the ground ? There are, of course, trials to which he may prove unequal. He may lose his way in a cloud, become exhausted when crossing a wide stretch of sea, or even fly stupidly into a telegraph wire. But an accident from want of balance would be evidence of morbid condition.

CHAPTER III.

MOTIVE POWER.

LEVERAGE—PROPULSION—PHASES OF THE WING-STROKE.

In describing gliding we have taken the motive power for granted, assuming that the bird already has momentum. We must now investigate his method of lifting and propelling himself. The lifting is the hard work, for the bird is so shaped that when he sets himself at a suitable angle the air offers but little resistance to his movement onward in a horizontal direction. To lift himself he must put great force into the downward beat of his wings, making their extremities move with such velocity that the air, the resistance of which increases as the square of the velocity, will very soon offer effective support. They will, in fact, become levers, each having its fulcrum mainly near the extremity, the weight to be lifted being, of course, the bird's body, or, more correctly, the whole bird. The power is applied quite close to the body (*see fig. 21, Chap. VII*). The depressor muscle, the great muscle that springs from the breastbone and covers it with its great expanse, attaches to the humerus (or upper-arm bone) close to the nearer end. With a lever like this there is no economy of power—very far from it. What is gained is rapidity of movement. A quick movement

of the near part of the wing will produce a movement of astonishing rapidity towards the further end, near the tips of the great primary-feathers.

If x (see the figure) moves half an inch, x will move two inches. Preparatory to the down-stroke, the wing is lifted till it points straight upward, its anterior margin being turned in the direction of the bird's flight. During the first part of its descent it

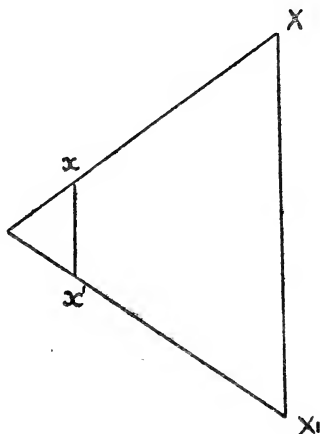

FIG. 15.

Diagram to show the velocity with which the extremity of the wing moves.

cuts edgewise through the air. But soon it turns face downwards and, the air opposing its descent, it finds a fulcrum. But, of course, there is some give. The fulcrum that the air supplies to the wing is, like the fulcrum that the oar finds in water, an imperfect one. When, however, the bird is taking full-length strokes, the wings appear to move with a far longer sweep than is really the case. With each stroke the

body rises, and this means a relative lowering of the wings.

It is a wonderful thing that the air can supply a tolerably firm support, something that will do duty as a fixed point. Archimedes undertook to lift anything if he could find a fulcrum for his lever. The bird finds a fulcrum where Archimedes would not have thought it worth while to look for one. The bird when flying is, in fact, taking a number of jumps. Often when he appears to be travelling in a horizontal line he is really, as Professor Marey has shown in his wonderful photographs that give successive phases of the process, rising and sinking with each down-stroke and up-stroke. Thus the bird's apparently horizontal line of progress is often an undulating one. But when he is travelling with great velocity, then there is no drop between the strokes; of this Professor Marey has obtained evidence. But there is probably some reduction of pace. Even though there is no rise with each stroke, the bird is nevertheless taking a series of jumps. And the marvel of these jumps, with no better take-off than the air, no amount of thinking can do away with. A man who is accounted a good high jumper can do very little if he has a poor take-off—if the ground is spongy. We all find it very hard work walking over soft snow when at each step we sink up to our knees before we find anything firm and resistant beneath our feet. We walk slowly and with labour along a beach where the small pebbles let our feet sink in. We climb with effort up a volcanic cone where, each step that we take, the small rounded ashes let us slide downward



Phases of the wing-stroke : photographs of Pigeons. A : Ready for the down-stroke. The series is continued on Plates V. and VI. (See Chap. III.)

till we lose almost all that we have gained. But the bird has to deal with a material that seems far more shifty and undependable than small pebbles or volcanic ashes, or than snow at its worst. He overcomes the difficulty by means of levers calculated to give the utmost rapidity of movement. The muscular effort required is great, but his muscles are strong, and it is long before they tire.

Propulsion.—Phases of the Wing-stroke.

But the bird has not only to lift himself, or to maintain the altitude he has already gained. He must also have onward momentum. Were this wanting, he could not even lift himself, for air has little or no supporting power when it has just been disturbed. He must, therefore, be perpetually advancing to fresh columns of air that have not yet been shattered by the beating of his wings. I have already pointed out that, when birds are flying in flocks, each takes care to keep clear of the backwash of the bird in front of him—takes care to avoid tracts of air that have already been disturbed; that a Pigeon, when he has a string tied to his leg, cannot maintain himself in air, however wildly he may ply his wings, when he has reached the end of his tether; that when a Kestrel hovers without advancing there is always a breeze, so that each wing-beat descends on fresh, unbattered air. For ordinary flight the wings must be so adjusted as to propel as well as lift. This the bird can effect only if the front part of the wing is lower than the hinder part. Thus the parallelogram of forces comes once more to his aid.

Let *F B* (fig. 16) represent a section through the

bird's wings, F being the front and B the back margin. The resistant air (w in the figure) will be equivalent to a wind blowing vertically upward. It will act at right angles to the plane of the wing, and the line representing its action will point not only upward but forward. During horizontal flight the front edge of the wing is slightly at a lower level than the back. But when the bird is rising and taking very

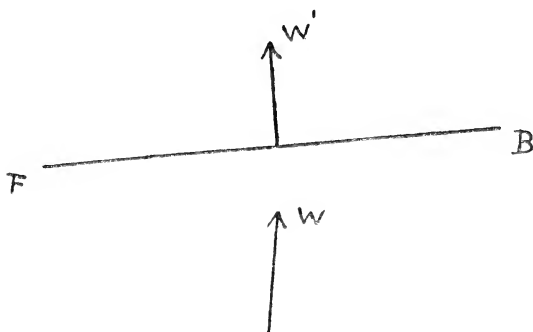
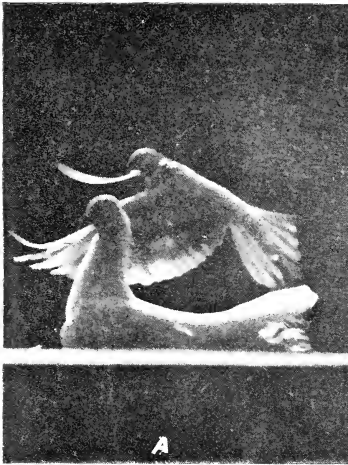

FIG. 16.

Diagram showing the effect of the lowering of the front margin of the wing.

energetic strokes, then the required incline is not obtained by that method only. The wing moves forward as it descends, so that at the end of the down-stroke, instead of making a right angle with the body, it points more forward than outward. When the wing is in this position, there is the downward slope that is wanted, from its base at the shoulder to the tip. One method passes gradually into the other ; indeed, the wing is inevitably shoved forward when the air lifts its hinder margin. On



Phases of the wing-stroke, continued from Plate IV. A : Last phase of the down-stroke. B : Beginning of the up-stroke. C : Feathers bent upward during the up-stroke (see Marey, *Vol des Oiseaux*, p. 268, and Plate at end). D : Up-stroke continued. Continuation of series on Plate VI. (See Chap. III.)

the forward-downward movement as giving the required incline I wish to lay stress, because treatises on flight do not, as far as I know, recognize this way of obtaining the downward slope, but speak only of the depressing of the front margin relatively to the back (*see* Pls. IV and V).

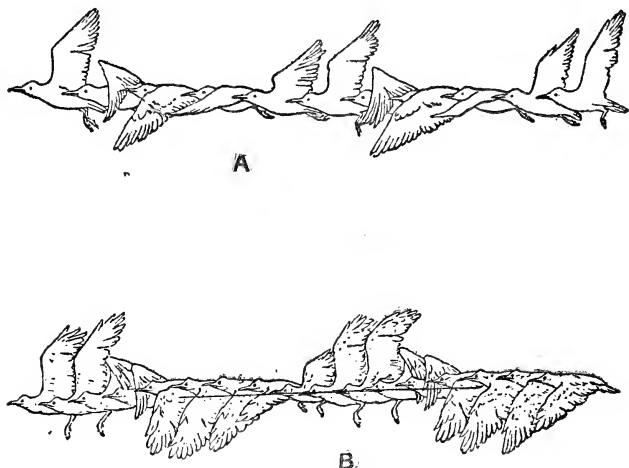
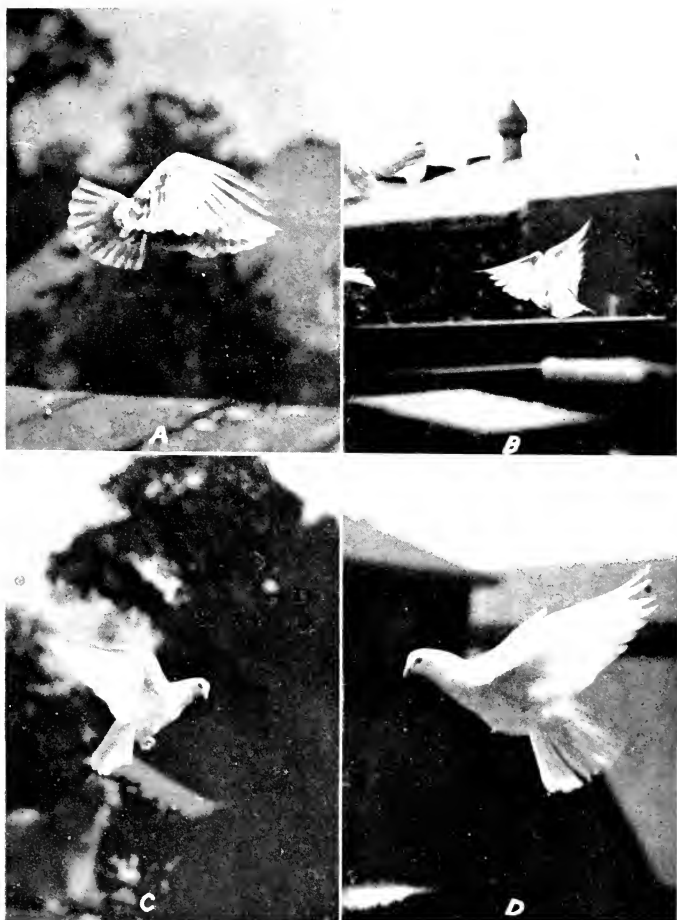

FIG. 17.

Gulls flying (after Marey). A.—25 photographs per second.
B.—50 per second.

I am now going to describe more in detail the different phases of the stroke. For this I must depend to some extent on Professor Marey's photographs. Other photographers, myself among them, taking snapshots, have caught the various wing positions. He shows us the various phases in series: they follow one another at the rate of 25 or of 50 per second (*see* fig.17 and Pls. IV, V, VI, VII).

I will first give some account of a long and complete stroke. Preparatory to the down-stroke, the wing is raised till it points vertically upward, its front margin being turned in the direction of the bird's flight. There may then be a moment's pause, the wing, as it were, resting before it strikes its blow. In the case of gulls the next move seems to be a slight bend at the wrist-joint. After this begins the serious work. The wing descends with lightning speed, so fast indeed that this early phase of the down-stroke does not always appear in the series when photography has succeeded in depicting all the other phases. The great rapidity at this stage seems to indicate that it is not till the wing is approaching the horizontal that it begins to feel the resistance of the air and do its work of lifting and propelling. When this work is going on, the upward bending of the primary-feathers leaves us in no doubt about the fact. As the wing descends it points more and more forward. The way in which this is brought about is highly interesting. The big muscle which lowers the wing attaches to the front part of the lower face of the humerus (upper-arm bone) (*see*, Chap. VII, fig. 21). Its pull, therefore, tends to lower the front of the wing relatively to the hinder part by rotating the bone. But the air, acting on the feathers that spread out rearward, greatly aids the muscle, lifts the hinder part of the wing, and encourages the rotation. But the work of the air does not end here. As soon as the wing has an upward incline from front to back, it cannot but move forward; the mere action of the air on a surface so inclined cannot but bring this about. Thus the upward incline from



Phases of the wing-stroke, continued from Plate V. A: Nearly the same as Plate V., and from a different point of view. B, C, D: Up-stroke continued. (See Chap. III.)

front to back, without which the bird would not make headway, is obtained first by the raising of the back part of the wing relatively to the front, and later, as the stroke advances, by the forward movement of the descending wing, which brings it about that the extremity occupies a position lower than and in advance of the base. For a moment let us consider the working of the wings in combination. With the body they form a kind of funnel—obviously one side of the funnel is missing, but this is unimportant. Caught in this funnel and deflected from the wing-surfaces, the air impinges upon the body and lifts it. When the wing has strained forward and downward till it can strain no further, the muscles at length relax. The wing is no longer rigidly extended, but slightly bent at the elbow-joint, and soon at the wrist also. If the bird is rising and has little onward momentum, the Elevator muscle does the work of lifting. The great flight-feathers, which during the down-stroke have been pressed close against one another and so have made the wing impervious to air, are now slightly rotated, so that interspaces are left which allow the air to pass, and thus the raising is effected without much opposition (*see* Chap. VII, fig. 24). If, on the other hand, the bird has much way on, the air itself effects the lifting and little work on the part of the muscles is required. After the strain of the down-stroke, the Depressor muscle ceases its contraction, and, perhaps, the Elevator gets to work. In any case the front margin of the wing is no longer depressed relatively to the hinder margin, but is lifted. The wing lets the wind have its way, and is carried

back, almost unresisting, but occasionally, as photographs show, it resists enough to cause a backward bending of the flight-feathers. It looks as if the bird, when his wings are being lifted by the rush of air into position for a fresh stroke, checked them for a fraction of a second in order to save himself from loss of altitude. It is possible this check in the course of the up-stroke may be the normal thing, or it may be only occasional (*see* Pl. v). When the wing is thus raised by the rush of air—more strictly by the resistance of the air to its momentum—the flight-feathers are pressed against one another and there are no gaps to make the lifting easy. But no such help is required. The wing is blown back as far as it has freedom to go, and at the end of its rearward movement it is no longer facing as it was; its under-surface is facing outward and its anterior margin is looking towards the bird's head. When the wing is in this position it is easy to raise it completely and bring it forward; in fact it moves edgewise. Anatomy supplies very remarkable evidence that the raising of the wing requires little effort. Whereas the muscle which lowers the wing is red, ridged, and granulated, the Elevator muscle is paler and exposes a smooth surface when it is cut. The former is by far the better class of muscle, capable of long, unflagging effort.

In ordinary horizontal flight most birds take a much shorter stroke than the one I have just described, nor is the wing pointed much forward (*see* Pl. VII). The upward incline from front to back that is needed is obtained by a slight lowering of the front margin relatively to the back, mainly

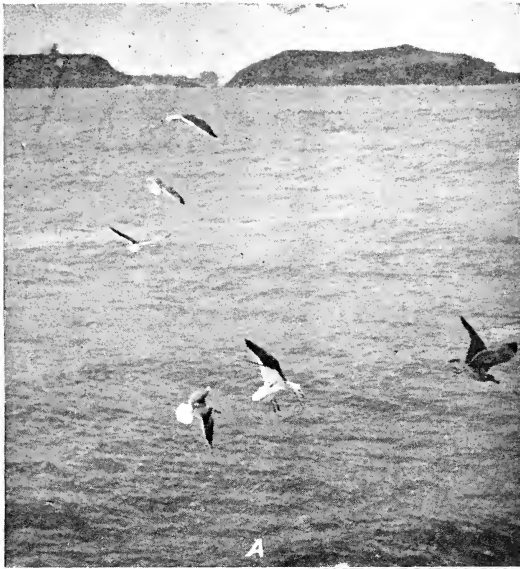

Gulls flying with short stroke. A: Lesser Black-backed Gulls. B: Black-headed Gulls; the lower bird on the left with wings bent at the wrist, shows an early phase of the up-stroke. (See Chap. III.)

towards the extremity of the wing, and this gives propulsion enough. This short stroke is the one adopted by gulls in their ordinary leisurely flight. The wings give the air a sharp slap, and this with a bird so well built for flight and so skilled is very effective. It is to be noticed that, when gulls are taking short, leisurely strokes, the wings during the down-strokes are very distinctly curved from their base to their extremity. This curve prevents a too easy slipping away of the air and so increases the wing's lifting power; but when a stronger stroke is taken the primary-feathers bend upward.

The question how a bird lifts and propels himself I have now briefly answered. In other chapters I shall try to describe the build of this living flying-machine, to my thinking the noblest of all craft that sail the air (*see* Chaps. VII, VIII, and XI).

CHAPTER IV.

STARTING.

THE PRELIMINARY JUMP—LOSS OF ALTITUDE BETWEEN WING-STROKES—THE WING'S FREEDOM TO ROTATE—AEROPLANES—MUSCLES—BIG BIRDS AND SMALL.

The Preliminary Jump.

I HAVE shown how a bird when flying maintains and propels himself, when we have given him in imagination a good start. We have now to study his method of starting.

Let us suppose that he is standing on the ground ; if he is to fly he must somehow get clear of it. For this purpose his long, strong legs are of great service to him ; it is owing to them that he is so good a starter. Such is the bird that I think of as typical. Not only are his legs strong, but they are long, unless we compare them with those of a Wader or a Heron, birds that for their particular mode of life have developed an inordinate length of leg. The Puffin and the Swift, by their helplessness on level ground, call attention to the remarkable leg-power of the ordinary small bird, or bird of moderate size. The Swift and the Puffin cannot take the preliminary jump with which flight must begin. Bulky, short-legged birds all rise with difficulty ; the jump that should in a moment obtain for them freedom of wing action is beyond their power.

PLATE VIII.



A and B: Pigeons starting to fly. B: A very hurried start. C: Pigeon rising with body inclined steeply upward. D: Herring-Gulls starting; photographed in September, when they were moulting. (See Chap. IV.)

It is not that they are deficient in lifting power, for it is said that an Eagle can carry a weight as great as its own, and I have seen a Falcon flying off with a victim that was not far short of itself in point of size.

Whether big or small, birds all fold their wings neatly upon their backs, where they cannot possibly interfere with freedom of leg action. In order to appreciate the excellence of this arrangement, we must compare the bird with the bat or with the pterodactyle, whose wings were remarkably bat-like. Extending, as they did, far back and attaching to his legs, they must have been as bad an encumbrance as long skirts. Though, no doubt, a fine flyer in a bat-like style when once launched on his way, the pterodactyle was a poor starter. The bird's legs, on the contrary, are not sacrificed to his wings (*see* Pl. VIII). Unless he is one of the specially bad starters, he jumps lightly into the air and is off.

With regard to the heavy, lumbering way in which many big birds rise, a great deal is to be learnt by watching a Heron start to fly from level ground. Unlike the Condor, the Comorant, the Puffin, and the Swift, he has no difficulty in getting under way. True, he does not rise with a steep incline as an ordinary small bird or a Pigeon can, but a gradual ascent he carries out without difficulty. He drops from the top of his long legs on to the spacious fields of air and is at once clear of the earth, with ample room for the plying of his wings. On the other hand, the big short-legged birds and small birds like the Swift, with very short, feeble legs, have no room for a full sweep of their wings,

unless they have, by some means other than a jump, attained some elevation. Hence the difficulty they have in starting from level ground. But even when this full sweep is possible big birds are still only capable of ascending with a gentle incline, and this is a fact that we must try to account for.

Loss of Altitude between Wing-Stroke.

To my thinking the explanation is this: since the big bird necessarily takes a longer stroke and requires more time to raise his wings for a fresh downward beat, he must inevitably lose more altitude between wing-strokes than the small bird. Professor Marey gives the rate of stroke for a number of birds as registered by means of scientific apparatus.*

				Strokes per second.
Sparrow	13
Duck	9
Pigeon	8
Marsh-Harrier		$5\frac{3}{4}$
Screech-Owl	5
Buzzard	3

In the case of a Sparrow it is evident that there is no time for a drop between the strokes, though compared with those of most insects even a Sparrow's wings move slowly and heavily. The leisurely working of a Heron's wings is familiar to everyone who ever takes the trouble to observe birds; usually he flaps along with only 130 strokes a minute or even slightly less. The Marsh-Harrier

* See his *Vol des Oiseaux*, p. 100.

has a much quicker beat, but even with such a rate as his a drop between the strokes is quite possible unless he has plenty of way on. And now we are getting to the explanation of the big bird's method of rising. In order to avoid losing altitude between the strokes, he must take care that he has momentum, and if he is to have momentum he must be content to ascend by a gentle incline.

The Wing's Freedom to Rotate.

Moreover, there is a want of freedom about his wing-movements which makes him incapable of anything but a very gradual ascent. If he were to incline his body steeply upward, after the manner of a small woodland bird that, making for a gap in the dense spreading boughs overhead, mounts almost vertically, he would have to rotate his wings in a way that is impossible for him; he would have to lower the front margin relatively to the back, or else they would beat in such a way as to drive him backward instead of lifting him. In fact, he has too little freedom at the shoulder. He cannot set his wings as a steep ascent requires. The small bird's wings, on the other hand, rotate so freely that even when he sets his body with a steep upward slant he can still turn them over so that they have an up-and-down beat and raise him skyward.

But though, speaking generally, the small bird is capable of a steeper ascent than the big bird, yet it would be a great mistake to imagine that if we were to arrange birds according to their weights, from the

lightest to the heaviest, we should at the same time be arranging them according to their angles of ascent—the angle which each makes with the horizon when the line of his ascent is as near to the vertical as his build and his powers allow. In the case of all very big, bulky birds, I believe the wing rotates reluctantly and with difficulty at the shoulder. The Gannet, Pelican, Cormorant, Eagle I have tested, and found that they have very little power of lowering the front edge of the wing relatively to the back; one Eagle was a partial exception. I have never had a live or a freshly-killed Condor at my disposal, but there is reason to believe that the Condor is among the stiffest of the stiff. The way in which Condors are trapped in Chile—it is described by Darwin in his *Journal of Researches* (Chap. ix)—supplies indirect evidence of the great bird's limitations. The plan is to place a carcass “on a level piece of ground within an enclosure of sticks with an opening, and, when the Condors are gorged, to gallop up on horseback to the entrance, and thus enclose them: for when this bird has not space to run it cannot give its body sufficient momentum to rise” from the ground.” In fact a Condor cannot rotate his wings and set them as they must be set if his line of ascent is to make a large angle with the horizon. As far as I know, all birds of great bulk have this defect, but when we come to birds of medium size we find great variations, and it soon becomes apparent that it is largely a question of habitat and environment. The Pheasant and Duck—I have tested the Mallard, the Sheld-duck and the Teal as representative of the Ducks—have great freedom of movement

at the shoulder, and can, moreover, point their wings forward so that at the finish of the down-stroke they have an upward incline from tip to base. On the other hand, the Partridge and the Herring-Gull have very little power of rotation. The striking contrast between the Partridge and the Pheasant throws a great deal of light upon the question. The Pheasant is a denizen of woods and has often to make for an opening in the branches that shows itself almost directly over his head. Heading straight for it, he points his body almost vertically upward, but, in spite of that, his wings have an up-and-down beat, and turn the concavity of their nether side towards the ground and their upper convex surface towards the sky. The Partridge, on the other hand, frequents plains and open fields where there are no entanglements to make a nearly vertical ascent even an occasional necessity. A Wild Duck sometimes finds it expedient to mount upward from her nest among the bushes in the same style as the Pheasant just described, and I have seen a Wigeon, without any apparent advantage to himself, shoot up thus from a large piece of open water. All birds, if we except those that frequent only open water, bare cliffs, bare hills or unwooded plains, may find, any moment, that they have to make a rapid ascent up a steep incline ; life itself may depend upon it. Hence great freedom at the shoulder is very common. I have observed it not only in the Pheasant and the Duck, but in the Jackdaw, Crow, Raven, Chough, Jay, Magpie, and Quail. No wing, I think, rotates more freely than that of the domestic Pigeon. Were it not for this, the bird in Pl. VIII could not achieve, as he is

evidently doing, the feat of an almost vertical ascent.

The big and bulky birds then, such as the Gannet and the Condor, having a much slower wing-stroke than the light-weights, must make it their first object to attain momentum, otherwise they will lose altitude between the strokes. When they have got way on, they can rise, but the line of their ascent is a gentle slope. For a steeper ascent the set of their wings unfits them. But there are birds of medium size, such as the Duck and the Pheasant, which, striking with very great rapidity and rotating their wings as freely as any small bird, are capable of raising themselves almost vertically through the air.

Aeroplanes.

In a country like England, with trees and hedges almost everywhere, an aeroplane capable of a steep ascent is a great desideratum. Captain Brooke-Popham, writing on military aviation, says that "with no wind a fully-loaded machine, with observer, could get off a hard level field in a length of 120 yards and clear a fair hunting hedge at the end. Our Air Battalion "Farman" can do this in 90 to 100 yards without any difficulty."* Thus even the "Farman" requires a great deal more space than a Condor or a Comorant, birds noted as slow, lumbering starters, and though aeroplanes are constantly being improved it may well be doubted whether a steep ascent will ever be achieved.

* *The Army Review*, January, 1912, p. 89.

Muscles.

To rise in air before he has got up pace is hard work for any bird unless he can get the wind to help him, for a great strain is put upon the muscle that lifts the wing. And here I may call attention to the remarkable development of the Elevator muscle in the Pheasant. Its weight amounts to nearly one-third of that of the Depressor. It is very pale and has little lasting power, but for a brief effort it is very effective. Its development in the Duck is considerable, but not equal to what is found in the Pheasant. As soon as the bird begins to travel rapidly, there comes an easier time for the overtaxed Elevator, for the resistance of the air to the onward impetus is sufficient to lift the wings, and the impetus is due mainly to the work of the great Depressor muscle. Hence the Depressor not only lowers the wing, but indirectly lifts it. The Elevator is not fitted for long-sustained effort. The Depressor is a redder, rougher, more granulated muscle, and its different colour and texture are indicative of superior quality.*

Big Birds and Small.

As a rule, when a small bird flies, his line of flight is undulating. For him to rise is easy; a few strong, rapid strokes lift him. He then partly flexes his wings and glides onward and slightly downward. This is very noticeable in the case of the Woodpecker. He flexes his wings more than most birds, and so the dipping character of his flight

* For more on this subject, see p. 45 and Chap. VII: Muscles.

is more conspicuous. The big bird, on the other hand, dare not lose altitude in so reckless a way, since when he has once lost it he with difficulty recovers it. He ploughs steadily on, whereas the small bird with a few rapid strokes gains altitude, then, like a bicyclist utilising his free wheel, glides restfully and rapidly onward, not minding the loss of some of the height he had gained. His stroke is more rapid, but he is able to take frequent easies.*

I have now compared and contrasted big birds and small, but even the biggest birds that fly are not very big; as compared with the larger mammals they are diminutive. Why, among all the birds that fly, are there none that weigh even half as much as, for example, a Zebra?

Helmholtz, dealing with this subject, produced a formula which, backed as it was by the authority of a great man, was too readily accepted, regardless of the fact that it was not founded on data obtained by experiment. There is nothing so misleading as mathematics when the premises are unsound. Helmholtz started with undeniable facts. If a bird's linear dimensions be multiplied by 4, then the area is multiplied by 16 (4^2), and the bulk, which must nearly correspond to the weight, by 64 (4^3). So far good. He showed that the weight increased more rapidly than the supporting area. But when he went on to maintain that the power required to lift the bird increased at a still more rapid rate—that, in the case I have taken, it would be 128 ($4^{\frac{7}{2}}$)—then he was building a theory without a proper foundation

* On big birds and small birds see Chap. I, pp. 18-22.

of proved fact. Even now, though the subject has been much studied, it would be very rash to venture on a formula. The big bird has great advantages. He can manage, as we have seen, with a relatively smaller expanse of wing, for the area, being greater absolutely, does not so readily allow the escape of air at the margins. Moreover, his wing, being longer absolutely, is a more powerful lever. The great weights which Eagles, for example, carry show that there is no deficiency of lifting power. But the big bird's wings have not the easiness of rotation at the shoulder-joint which makes it possible for a Greenfinch, for instance, or a Pheasant, to rise with a steep incline ; he cannot put himself in the right attitude. It does not appear, however, that bulk in itself is any handicap.

If this be so, it may well be asked why even big birds are quite small when compared with the larger mammals. I have already pointed out that the big bird, if his legs are short, has difficulty in beginning a flight, and so lacks a very important accomplishment. Then why are they not all mounted on stilts, like the Flamingo ? But legs of such length, or even the half of it, would for many birds be most inconvenient appendages, for a diving bird most of all. They would not help him to rise from the water, and they would be clumsy things beneath the surface. And thus among big birds there are many that for purposes of flight are handicapped by shortness of leg. Diminutive size brings with it another advantage. The small bird comes more rapidly to maturity. In his second spring, when he is not yet twelve months old, the Blackbird has already paired

and is busy nesting. The Gannet is known, I believe, not to nest till his fifth year; the Eagle comes to maturity later, possibly not till his tenth year. In rate of reproduction, therefore, a most important matter for the species, the small bird has a great advantage. And thus we can account for the small size of birds compared with that of mammals without recourse to any such theory as that of Helmholtz. The small bird is a better starter than the big, and he comes to maturity more quickly.

CHAPTER V.

STEERING.

A VARIETY OF METHODS—GOOD STEERERS AND BAD.

A Variety of Methods.

A BIRD can steer when his tail is gone. A Rook, when some accident has robbed him of this useful rudder and balancer, can still make shift. He is not like a ship left rudderless. It is evident, therefore, that the tail is not the bird's sole steering apparatus. If he wishes to steer to the left his usual method is to fling himself on his left side, the left wing pointing downward and the right wing upward, the two being in line with one another, while his head is pointed in the direction in which he wishes to travel (*see* Pl. IX). Then he can no longer progress along his former line of advance, for the expanse of his wings will check him. He travels, therefore, to the left, i.e. towards the point towards which his head is directed. But how does he effect the necessary change of balance? There is no doubt that he occasionally gives a harder stroke with one wing than the other, a thing which the camera sometimes detects, though it is difficult for the eye to see it clearly. On Plate II are some photographs in which the wings have been caught

at a moment when they were not held symmetrically. Another plan is to bend sideways at the waist, so as to move the centre of gravity towards one side. I was long doubtful whether this plan was actually adopted. At length I have obtained a photograph of a Gull, taken from below, where the waist, thus bent, is clearly shown, but unfortunately this photograph will not stand reproduction. Below I give some measurements which show that birds that are good steerers have greater suppleness of waist than clumsy steerers.

The tail also is undoubtedly used for steering, though, I believe, it is more frequently of service in maintaining or restoring equilibrium. The rule is, as I have shown, that if the legs are long the tail is small, and as it is indisputable that long legs are very useful for balancing and of but little use in steering, we may infer that the tail is more a balancer than a rudder. Nevertheless, it is of much use in steering. Though its edges look to right and left, it can be made an effective rudder by the lowering of one side more than the other.

Web-footed birds probably use their feet occasionally for steering purposes, but I doubt if their action counts for very much. When a Duck, for example, is hurtling through the air, if he lowers one foot, the resistance of the air will double it up, not expand it. It is very different when a Duck in swimming kicks backward; the water acts upon the under-surface and spreads the webs to their fullest extent. Some birds when alighting use their feet in the same way. A Gannet, for instance, kicks hard in order to correct his balance



A



B



D

A and B: Gulls steering by throwing themselves on one side. A: Steering to the right and looking to the left. C and D: Pigeons showing the tail used as a rudder. (See Chap. V.)

and get into the right attitude for settling. It is a clumsy performance.

The movement of the head to one side or the other has, no doubt, some slight influence on the balance. But the skull is very light, a great part of it as thin as paper, and one may occasionally see a Gull look to the left while he steers to the right (Pl. IX), just as a skater, who is quite at home on his skates, can make such minor movements without in any way upsetting his balance. This subject naturally brings to mind the wonderful way in which Mr. Cody showed the lateral stability of his biplane. He carried a passenger who stood at a distance of ten and a half feet from the centre where he himself was piloting. When a bird turns his head, it is far more probable that he is directing his eyes, to right or left, towards some object that has attracted his attention, than that he is regulating his balance. Mr. Bentley Beetham has a capital photograph* in which he has caught five Gulls in the act of turning their heads to the right. This may possibly be due, as he suggests, to a local current of air with which they all equally have to cope. But it seems far more likely that they have all suddenly caught sight of some object of interest, a fish or shoal of fish, at no great distance. What would one not give for a photograph of a large flock of birds scudding through the air high aloft—for a photograph taken at the moment when by some common impulse, as if following some leader, they each and all change their course? Might we not see, if we could obtain such a photograph,

* *British Birds*, Dec., 1910.

all the heads turned one way, the object being to follow with the eye the movements of the leader or leaders of the flock ?

Good Steerers and Bad.

There are good steerers and bad steerers. Contrast the Swallow, the Lapwing, or the Sparrow-Hawk, those adepts at sudden swerving and doubling, with the Duck! The Duck becomes the slave of his own ponderous momentum, and changes his course slowly and with effort. The Swallow, the Lapwing and the Sparrow-Hawk have all of them a fine expanse of tail, while the Duck's is small in area and, what there is of it, feeble. Efficiency or inefficiency of tail, no doubt, accounts for a great deal. But it is not the only factor to be considered. The Duck, though very strong, is lacking in agility; the three other birds have far more suppleness, I believe, notably at one important point. Though birds' backbones are, below the neck, very stiff, yet they allow of a good deal of bend, either up and down or sideways, at the waist. I have measured the amount of sideways bend in some few species and found that, as far as my far from complete evidence goes, good steerers

Angle formed by backbone
bending sideways at waist.

Kestrel	141·5°
Swallow	150°
Swift	153·5°
Common Tern	155°
Kestrel (another specimen) ..	156°
Domestic Duck	165°

have supple waists and poor steerers comparatively stiff ones, the Duck being a good deal the stiffest of those I have examined.

It is difficult to account for the difference between the two Kestrels, but there is no doubt that the Duck is, of the birds in question, decidedly the stiffest. In fact these measurements make it *a priori* probable that suppleness of waist counts for a good deal. The result of the sideways bend must be that the bird is thrown on to its side—the attitude which is assumed when a sudden turn is to be made.

For steering purposes, then, a bird has various methods at his disposal. He can take unequal wing-strokes or bend at the waist. Either of these means will put him in the attitude in which we see him steering to right or left, one wing pointing downward, the other upward. And he can use his tail as a rudder. Some birds may, no doubt, steer partly by means of their feet, but I doubt whether a foot is a very effective rudder. The Duck's webbed feet do not seem to make him an adept at turning.

CHAPTER VI.

STOPPING AND ALIGHTING.

A bird alights without any jar. Let us imagine that when we first catch sight of him he is flying at some height above the ground. Wishing to descend, he will give his wings an upward slope and float down in the style usually preferred by Pigeons, or more probably he will slant his body, from tail to head, downwards and, partly flexing his wings, glide rapidly towards the earth. On nearing his landing place he will suddenly let his hind-quarters sink, and give his body an upward incline ; his wings, spread wide, present their whole under-surface to the air. This soon checks his momentum. But if he wants to make a very sudden stop he gives a stroke with his wings, and this, when the body is nearly upright, as a glance at one of the photographs (*see Pl. x*) that illustrate the process will show, must bring him at once to a standstill. And just after landing, perhaps (notably if he is a Tern, a Lapwing or a Pigeon) he will raise his wings high above his head as if to stretch and refresh the muscles, in which attitude he looks very beautiful. A beautiful thing, too, is the folding of the wings ; it is all so quickly and so neatly done. A Tern or even a Pigeon when he alights has all the grace of the "Herald Mercury, new lighted on a heaven-kissing hill."

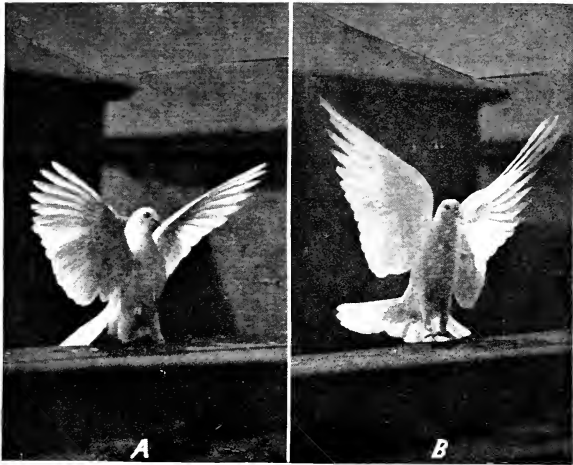

A and B: Pigeons alighting. Though in B the feet are still clear of the window-ledge, I think the bird is giving his wings the final stretch that with many species is preliminary to the folding of them. C: Pigeon checking speed before alighting. (See Chap. VI.)

As birds are so careful in alighting to avoid all jar, it is remarkable that some species have habits which would seem likely to cause concussion of the brain. It is astonishing that the Nuthatch, for example, when he has been half the day hammering at nuts with tremendous vigour, yet suffers no bad consequences. But we must bear in mind that the bird's neck, with its peculiar saddle-and-rider vertebrae, is more supple than a snake, whereas the backbone, except just at the waist, is remarkable for its rigidity. Hence, probably, the care and dexterity in alighting that contrast so strikingly with the reckless use of the beak and head as a hammer by the Nuthatch, the Woodpecker, and other birds. It must be owned that there are some birds which, when they are alighting, are very unlike the "Herald Mercury." Among these we must count the Gannet. When he gets near his nest upon some cliff, he paddles hard with his legs, and at last settles clumsily down. Mr. Bentley Beetham (*British Birds*, May, 1911) has some very good illustrations of the Gannet's style of alighting. One of them shows a bird that has so lost command of his movements, that he is flopping most ungracefully onto his nest. His breast is resting on the pile of dry seaweed, his outspread wings on the rock at either side. It is an astonishing attitude, but it must be borne in mind that the Gannet is in the habit of taking headers from a great height, and that his breast is shielded by air cavities beneath the skin, first-rate air-cushions that greatly reduce the shock when he dashes into the water. This may account for his descending breast foremost onto his nest. But the Cormorant, who has no

air-cushions, though he is the Gannet's near relative, is also clumsy in alighting, and Mr. H. F. Witherby has described to me how Cormorants, wishing to alight upon a post, will sometimes make a bad shot, pass it, and have to turn and try again. A Gull will alight gracefully enough on the water, but when he is aiming at a particular spot on a rock, for example, he will often paddle as awkwardly as a Gannet. The Lapwing is in a very different category; he is noted for his power of suddenly stopping, of making every possible turn. When you get near his nest he has a way of flying at you in threatening style, then suddenly checking himself and making off. He is a perfect master of bluff. A pair of Lapwings, by such menacing swoops and turns, will drive off a Crow whom they suspect of looking for their nest. In order to stop suddenly, what is wanted is a great expanse of feather, and I cannot help associating the Lapwing's remarkable wings—they are so strikingly broad at the extremity—with his well-known shock tactics.

I have already remarked on the skill which small birds show in alighting on their perch. Were a Linnet not very clever at making all the required adjustments, she would seldom reach her nest, somewhere deep in a gorse bush, without accident.

CHAPTER VII.

THE MACHINERY OF FLIGHT.

THE BREASTBONE AND THE CONNECTED BONES—MUSCLES AND QUALITY OF MUSCLE—THE SCAFFOLDING OF THE WING—PNEUMATIC BONES—STIFFNESS OF WING—EXPANSE OF BONE—THE SPREADING OF THE WING—STRUCTURE OF A FLIGHT-FEATHER—MOULTING—LEGS.

When we carve a Partridge or a Grouse, since other questions seem at the time of more pressing interest, we seldom give a thought to the fact that we are slicing and disjointing what has been a most marvellous flying machine. Yet so it is. When we carve the breast, we first cut through the Great Pectoral, the powerful muscle that lowers the wing. Lying below it we find, easily distinguishable, a much smaller, lighter-coloured muscle—in the Grouse and its kin markedly lighter. This smaller muscle lies in the angle between the keel and the sternum (or breastbone) proper; its work is the lifting of the wing.

The Breastbone and the Connected Bones.

The framework, the bony skeleton, is wonderfully adapted to the purpose to which it is put. It is most important, to begin with, that there should be a wide expanse of bone from which the great flight muscles may spring. And so the area of the sternum is increased by the large projecting keel.

The Ostrich has no keel, and is incapable of flight. The Hoatzin, that curious South American bird, according to all observers a most feeble flyer, has the front part of the keel missing. In every case the shape of the keel has its significance and is well worth observing, since it indicates the style of flight. The Duck and the Guillemot, having very long breastbones and keels, have of course very long flight muscles and a long muscle is capable of more

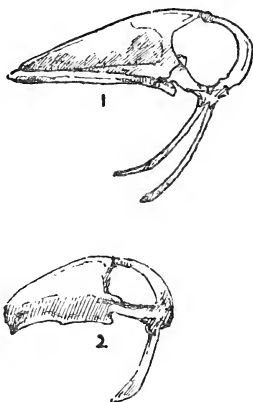

FIG. 18.

Breastbones of (1) Guillemot—actual length of keel $5\frac{1}{2}$ inches. (2) Falcon. Drawn to scale. Compare that of the Adjutant, a Stork famed for his soaring.

contraction than a short one. A glance at their breastbones, therefore, tells us that they are birds that fly with a long stroke. A Guillemot's wings are so small that a long, strong stroke is a necessity for him. A Duck, during horizontal flight, does not raise his wings very high, but the stroke is prolonged till the wings can strain no further downward.

The Tern and the Falcon, on the other hand, have short, deep keels, and therefore short but big and strong flight muscles. Accordingly, their ordinary stroke is short but powerful. It is highly important also that there should be a firm pivot on which the wing may rest as it moves. During part of the wing's down-stroke there must be considerable

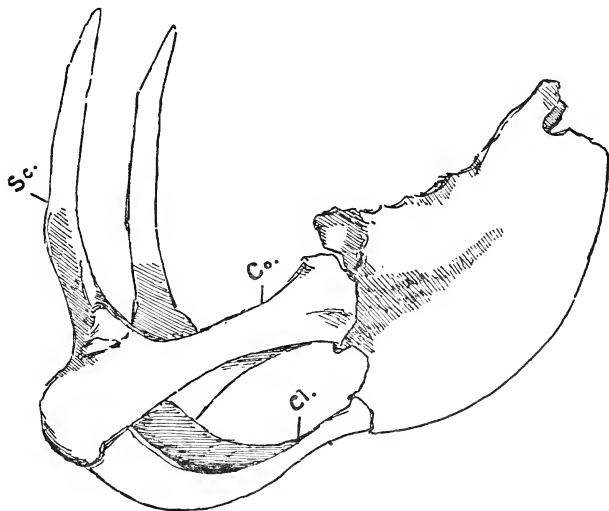

FIG. 19.

Breastbone and connected bones of Adjutant—actual length of keel $4\frac{3}{8}$ inches. Cl.: Clavicle; Co.: Coracoid; Sc.: Scapula.

pressure inward, and were the skeleton to give, were it to supply only an unsteady wobbling pivot, vigorous flight would be out of the question. How is the pivot formed? There is a strong bone, the coracoid, which springs from the front part of the breastbone and points forward and outward. It

slopes more outward in strong than in weak flyers, and, as a rule, more in big birds than in small. At the shoulder-joint the coracoid is met by two other bones, the clavicle or merrythought (which varies much in make and strength), and the scapula or shoulder-blade, and the three bones together form a first-rate pivot, so that the strong wing-beats do not shatter the bird's framework.

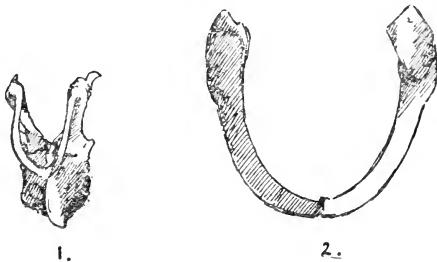

FIG. 20.

Clavicle of (1) Tern ; (2) Eagle. Drawn to scale.

Muscles and Quality of Muscle.

From the keel and from the outer part of the sternum (thus covering up the small Elevator muscle), and also from the clavicle, springs the Great Pectoral—the Depressor muscle ; it attaches by a short tendon to the front part of the under-surface of the humerus (upper-arm bone), and, attaching where it does, its pull tends to lower the front part of the wing relatively to the back. And springing as it does not only from the breastbone but also from the clavicle, it pulls the wing, not downward and backward, but simply downward. The underlying Elevator sends out a long tendon that passes

through a little tunnel formed by the three bones, which meet at the shoulder-joint, and after passing through the tunnel attaches to the upper side of the humerus, near to its preaxial or front edge. Its action is to erect the wing upon its pivot. Attaching



FIG. 21.

Humerus of right wing of Eagle. Actual length $6\frac{3}{4}$ inches. D : Flat area near the front margin of the under-surface, where the tendon from the Depressor muscle attaches.

where it does, it must necessarily bring the wing into the proper position for beginning the next stroke with its front edge looking in the direction of flight.

Sometimes, in order to carry out a movement, two muscles have to antagonise one another. When a bird wishes to check his speed suddenly, he lets his body hang downward, sometimes almost vertically, and holds his wings so that their under-surface faces in the direction of his flight. Now, if the Depressor were alone holding the wing, it would lower the front relatively to the back, and the resistance of the air would reinforce its action, making the wing turn its under-surface downward as in ordinary flight, whereas for checking speed it must face to the front. To orient it thus, by holding fast the front margin of the upper face of the humerus, is the work of the Elevator. The antagonising of one muscle by another is, of course, constantly going on. Were it not for this, with its steadying effect, no movement could be carried out with precision, no attitude could be maintained. There are, of course, other muscles which contribute to the working of the bird's wing, and, notably, there is a third pectoral, the office of which is to draw the wing back. But it is no part of this short treatise to describe the work of minor muscles.

I have already alluded to the different qualities of muscle found in birds. Muscle of the highest quality—capable of an enormous number of very rapid contractions in rapid succession—consists of fibres in which the fine striation in the direction of the pull of the muscle is much obscured by irregular, highly granulated cross ridges. In colour it is a rich red. The fibres consist of small, contractible fibrillæ, and are buried in a granular material known as sarcoplasm. Muscles which are capable of long-

continued exertion are rich in sarcoplasm, which would seem somehow to supply food to the muscle proper, to the contractile fibrillæ; at any rate this is a reasonable theory that explains the facts.* Now the muscle which in strong-flying birds is reddest and, in section, most ridged and granulated, is the Great Pectoral that lowers the wing. This is a muscle of great size, as I have already pointed out, and its output of unflagging energy is truly astonishing. The Elevator muscle is paler and smoother, and almost certainly of far inferior quality. Much less is demanded of it. As soon as the bird has got up pace, the resistance of the air lifts the wing, and the Elevator has little to do. In fact the great Depressor may claim to lift the wing, since to it is due the velocity which relieves the Elevator of its work. In the Blackcock, the Red Grouse and the Ptarmigan, the paleness of the Elevator forms a striking contrast against the rich red of the great muscle under which it lies. Among birds whose flight muscles I have examined, the Guillemot is the only one whose Elevator is as rich a red and almost as stringy as the Depressor. Is this explained by the fact that the bird uses his wings in swimming? Has he to raise his wings in the water by muscular effort? And is this due to the fact that when he swims he has less pace than when he flies? In the Chicken, since it seldom uses its wings, all the Pectoral muscles are very pale and smooth. The wild Jungle Fowl, from which our domestic bird springs, uses its legs far more than its wings, and, I believe, domestication has not much altered the

* See Starling's *Physiology* on quality of muscle (pp. 87, 88).

character of the different muscles. Remarkable also is the large size of the Chicken's Elevator muscle. Its wild kinsman, haunting the jungle as it does, has to rise to its perch without any wind to help it, so that all the work of raising the wing must fall upon the muscle. But the effort required is not a prolonged one, and so the muscle is pale. In the Sparrow-Hawk and, I believe, in other birds of prey, the Elevator is very small. Since they usually start to fly from a perch at some height above the ground, there is no difficulty in getting up speed enough to make the office of the Elevator largely a sinecure.

The brown flesh on a Chicken's leg, though the human palate pronounces it inferior, is, nevertheless, when regarded as muscle, of distinctly better quality. The Fowl is primarily a runner, not a flyer; hence, presumably, the darker colour and the greater strength and endurance of the leg muscles. Moreover, these muscles are kept on the strain throughout the night; by the bending of the knee and ankle joints the machinery of muscles and tendons throughout the leg is set to work and the bird's toes strongly grip the perch. His weight keeps the legs bent, and the bending of the legs keeps muscles and tendons to their work. Were they to relax for a moment the bird would probably lose his life; he would fall to the ground and some hungry carnivore, that happened to be prowling about, would seize him. But though in the Fowl the leg muscles are darker in colour than those of the breast and wings, they are not in section ridged and granulated like the great Pectoral of birds that are strong flyers. In the Moorhen, I have noted that the leg muscles are rather more ridged

than is the Elevator, but not so much as the Depressor. In most birds that I have examined, I have found that the leg muscles show less ridging and granulation even than the Elevator. But the Moorhen makes great use of his legs. He is both a swimmer and a runner. When not swimming he is generally walking on the grass beside his pond or stream, busied with the search for worms.

Before I leave the subject of quality of muscle I must point out that the inferiority of the pale to the red has been noticed also in thoroughbred horses. Mr. J. B. Robertson, in his very interesting paper on the *Principles of Heredity applied to the Racehorse* (p. 22), writes: "The pale fibres greatly predominate in the tissues of a pure sprinter, and the red fibres in those of a stayer."

The big muscles, the work of which I have described, are all massed upon the sternum. Even the muscles which bend or straighten the wing at the elbow spring not from the humerus or upper-arm bone, but from the top of the coracoid and the anterior end of the shoulder-blade respectively. I once cut off the wing of a domestic Pigeon as close as possible to the body and found that it scaled just under $\frac{4}{5}$ oz. The bird weighed $13\frac{1}{5}$ oz. Thus the two wings together accounted for just under one-eighth of the whole. It is wonderful that such strength can be combined with such lightness. And not only is the wing, as a whole, light; what weight it has belongs almost entirely to the bones and muscles of the near part. This Pigeon's wing balanced, when rested on a wire $2\frac{1}{2}$ inches from its base and 10 inches from its tip. The great primary

feathers (i.e. those which arise from the hand) point mainly outward and only slightly backward. Hence the length of a bird's wing is due largely to feathers, and they are proverbially light things. Their strength is no less remarkable than their lightness.

The Scaffolding of the Wing. Pneumatic Bones.

The scaffolding of the wing is itself very light. The thickest of the bones, the humerus, is hollow in big birds that are strong on the wing. In some the bones are hollow right on to the finger-tips; there is an opening in each bone at the near end (*see fig. 22*); a thin pulmonary membrane enters there, and thus they are filled with air that has passed through the lungs. The Gannet is a good example of this complete aeration. Many small birds, however, though first-rate flyers, have all their wing-bones solid; the Swallow, for example. The Swift has only the humerus pneumatic. The differences between nearly related birds are remarkable. The Gannet's remarkable pneumaticity I have already mentioned; his near relative, the Cormorant, has only the humerus pneumatic. Such examples seem to make it clear that aeration is an adaptation to the life and habits of the particular species, not an unvarying character firmly established in certain orders of birds.*

The fact that large birds have more aeration than small demands explanation. But the explanation

* Besides the wing-bones, the Gannet has the following bones pneumatic: The vertebrae, the greater part of the sternum (not the keel), the ribs, the coracoid, the ischium and the femur. There are also ample air-cushions beneath the skin that covers the breast.

is not far to seek. The small bird would gain but little in lightness by the aeration of his bones, since each bone consists almost entirely of its exterior shell. The big bird, with his stout, bulky bones, will gain far more. Here is a case in which we may appropriately quote some geometrical facts. We have seen above that if we take two cubes, the side of one of which is twice that of the other, then a face of the larger one is four times the area of a face of the smaller one, and the cubic content of the larger is eight times that of the smaller. Thus an increase in the length and girth of a bone means a far greater increase of the space within the outer shell. Obviously, then, a big bird stands to gain more in lightness by the hollowing of the bones. How he manages to do with so very little marrow—the bones having only a very thin lining—is another question to which I hope to return (*see* Chap. XI).

How much the bigness of the bone has to do with pneumaticity is made clearer by the facts which follow. If we make measurements of the humerus of a Skua, or other Gull—the Gulls have very little aeration—and of an Eagle as the representative of the birds which have a great deal, we find that the girth of the Eagle's bone is disproportionate to the bird's superiority in length of wing. And the explanation, no doubt, is this; the Eagle requires much greater strength in his wing-bones than does the Gull. Even a small increase in length of wing means a considerable increase in the pace at which the extremity will move. And, as we have seen, the resistance of the air increases as the square of the velocity. It is easy to see, then, that the Eagle and

other big, long-winged birds have wing-bones of larger girth (of a girth, that is, disproportionate to their superiority in length of wing) in order that they may be able to bear the far greater strain put upon them. A proportionate increase in weight would, no doubt, have caused difficulty, and this has been obviated by the aeration of the bones.

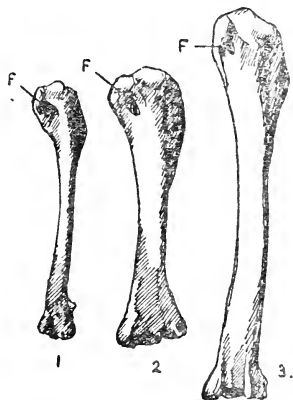

FIG. 22.

Humerus of (1) Skua ; (2) Rhinoceros Hornbill ; (3) Sea Eagle —actual length $6\frac{3}{4}$ inches. Drawn to scale. F: Foramen, where the bronchial membrane enters, on the upper surface.

To bring out this point more clearly I have taken the humerus of the Skua as the standard, and have calculated what would have been the length of the same bone in the Sea Eagle if it had been built on the same lines.

After all this I have to admit that there remains a very puzzling case on which I cannot throw any light. The Hornbills are slow, heavy flyers, they are not very big, and they are the most pneumatic

	Girth of humerus.	Humerus.		Aggregate length of wing-bones.	
		Actual length.	Length proportionate to girth.	Actual length.	Length proportionate to girth of humerus.
	Ins.	Ins.	Ins.	Ins.	Ins.
Skua ..	$2\frac{5}{32}$	$4\frac{3}{8}$	$4\frac{3}{8}$	$13\frac{5}{8}$	$13\frac{5}{8}$
Sea Eagle	$1\frac{5}{16}$	$6\frac{3}{4}$	$7\frac{7}{20}$	$20\frac{7}{8}$	$22\frac{1}{20}$

of all birds. The huge hollow beak is characteristic of the whole skeleton (*see* fig. 22).

Stiffness of Wing. Expanse of Bone.

It is highly important that the bird's wing when extended should be rigid—its bony framework, that is. It has elasticity where it is wanted, the elasticity of the great feathers, which tends, as I have shown, to make the bird automatically stable during flight. The stiffness of the scaffolding of the bird's extended wing is most remarkable when we compare it with the human arm. If we extend one of our arms horizontally to its full length with the palm of the hand downward, we can, while still keeping the upper arm lifted, bend the elbow-joint and point the fore-arm vertically upward. As the bird's wing descends with great velocity through the air, it does not give at the elbow, but remains rigid. But the stiffness of the bird's wrist is still more striking; when the wing is extended hardly any up-and-down movement at that point can

take place. The rigidity there is more easily brought about owing to the fact that of the two small rows of wrist-bones the further one has been fused with the hand-bones. When the fore-arm is brought into line with the upper arm, the hand also falls almost into line and is held tight in that position by ligaments. As soon as the wing is flexed at the elbow, it bends also at the wrist—bends backward, that is, towards where digit 5

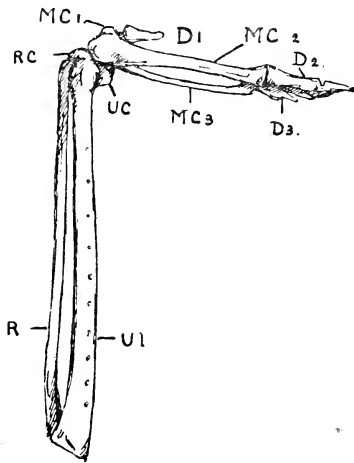

FIG. 23.

Skeleton of wing of Adjutant (from the elbow). D 1, 2, 3 : Digits 1, 2, 3. MC 1, 2, 3 : Metacarpals 1, 2, 3. R : Radius. RC : Radial carpal. Ul : Ulna. UC : Ulnar carpal. The marks left by the little pockets in which the secondary feathers are planted can be seen on the ulna.

would be if it existed—and then at the latter joint much freer upward movement also is possible. And so the wing is rigid when rigidity is wanted, and pliant when pliancy is in demand (*see* fig. 23).

It is essential, too, that there should be a large expanse of bone, a firm foothold for the great flight-feathers. The lizard, or lizard-like reptile, from which birds are undoubtedly descended, had a very wobbly hand. Even the Archæopteryx, the most ancient of birds, though it was beyond doubt a true bird and not a bird-like lizard, had three long fingers which show no sign of becoming fused together. With birds as we know them, things are very different. The three surviving metacarpals, or hand-bones, enlarged by the fusing with them of the further row of carpals or wrist-bones, are themselves fused together, the two of the three that are the most important fused both at the near and further ends. Of the three surviving digits two are fused; the little thumb, that supports the bastard-wing, remains independent and insignificant; and the result of all the fusing is that a broad, firm platform is provided for the feathers. Thus we see that the scaffolding of the wing when extended is remarkably rigid in spite of its lightness; its wide expanse of feathers is remarkably elastic, and is planted on a broad, firm base.

The Spreading of the Wing.

The machinery by which the wing is spread is well worth study. The rapidity with which it does its work is wonderful, and the accomplished result is most beautiful. When the triceps muscle straightens the wing at the elbow-joint, it is straightened also at the wrist, not absolutely but nearly; there are special muscles for giving the finishing touch. Of the two bones in the fore-arm the front one (the

radius) is pulled towards the body when the elbow is straightened and this straightens the wrist. A further result inevitably accompanies the first straightening movement. There is an elastic ligament that stretches from the armpit to the extremity of the digits. Through this pass all the secondary flight-feathers and, in every bird in which I have traced its course, all the primaries (those that spring from the hand). Part of this ligament is shown in

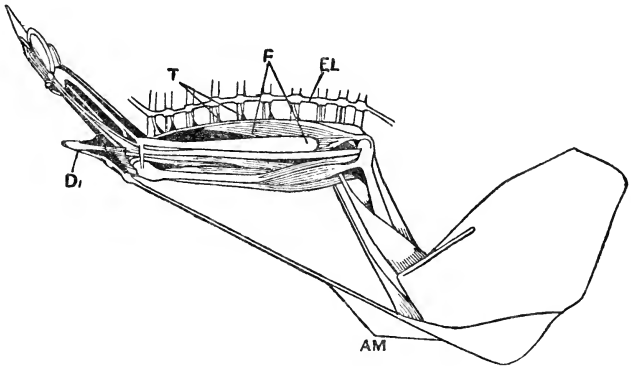

FIG. 24.

Wing viewed from below (after Alix, with a slight alteration, *see text*). AM: Muscle and tendon supporting anterior membrane, D1: Digit 1. EL: Elastic ligament. F: Flexor carpi ulnaris, dividing into two. T: Tendons connecting muscle with quills.

figure 24. But it is easy to see the whole of it in any bird's wing when the small covering feathers have been removed. The straightening of the wing stretches the ligament and the great flight-feathers spread like a fan.* (*See Pl. XI.*)

* There are differences in different families. In some the ligament, instead of being pierced by the quills, fastens only to their under-side.

There is another ligament which fastens to the under-side of the quills of the secondaries nearer to their base. Moreover, the secondaries grow backward, and plant themselves each in a little pocket of very tough fibrous tissue. These pockets are firmly rooted in the hinder of the two bones of the fore-arm (the ulna) and leave, each of them, their mark on it (*see fig. 23*). Planted thus, the secondaries, though very firmly gripped, have freedom to rotate. The primaries, pointing outward as they do, run along above the hand and finger bones and are held with a still stronger grip.

It is marvellous machinery which spreads the wings so rapidly, and which, having all its heaviest parts massed upon the body or very near to it, leaves them splendidly light, especially near their extremities. But we have not yet come to the end of the contrivances. During the down-stroke the secondaries press each against the one above it and so prevent the passage of air, whereas during the upstroke they let it pass. They are held fast by a number of stays; there are the little pockets just described, the ligaments and a sheet of fibrous tissue extending from their bases to the great ligament. There are also little tendons that connect the secondaries with a muscle which, arising from the further end of the humerus, attaches its other extremity to one of the wrist-bones (carpals) and to one of the metacarpals, or hand-bones, beyond (*see fig. 24*). Working unopposed it bends the wrist. When the wing is straightened it helps by its opposition to hold the wrist-joint tight, thus strengthening a point where the strain of flight is much felt. When

the wing is bent the muscle lies in a slightly curved form—we notice it when we are getting the meat from between the two long bones of a chicken's wing. It is straightened out when the wing straightens, and this, combined with the outward slope assumed by the feathers as they spread, stretches the little tendons that arise from it and are fastened to the feathers. The tendons slope outward, away from the shoulder, and attach to the under-side of the quills, or rather to the fibrous tissue with which the quills are surrounded. M. Alix (in his *Appareil locomoteur des Oiseaux*) makes some of them at any rate attach to the further edge of the lower face of the quills, and gives them the credit for rotating the feathers during the down-stroke, so that they press against one another and make the wing impervious to air. But when I have scraped these little tendons away in the wing of a freshly-killed Pigeon I have found that, when I extended the wing, the feathers still took their proper position. The extending of the wing causes a stretching of all the important stays—the ligaments, the sheet of fibrous tissue, and these tendons—and the ligaments may claim the largest share of the credit for the spreading and marshalling of the feathers. During the up-stroke the secondaries are firmly tethered, but are no longer marshalled for action. There are interspaces as there are between the leaves of a folded fan that has seen much service. The feathers being now no longer pressed tight together, the air can pass between them. When, however, the bird is flying fast and the wings are lifted, not so much by muscles



A : Wing of Lark, showing the elastic ligament that holds the primary and secondary feathers. Another ligament nearer to the base is faintly shown. B : Primary wing-feathers of Black Vulture (on left) and Pink-footed Goose, upper surface ; of Heron, under surface ; and outer tail-feather of Heron. In all the inner web is the broader. (See Chap. VII.)

as by the resistance of the air, the feathers during the up-stroke are pressed against one another and the passage of the air is prevented. But this causes no trouble. The wing is very rapidly swept backward and upward; it turns its front edge in the direction of flight, and when it is oriented thus it is easily straightened and moved forward into position for beginning the next down-stroke.

During the down-stroke the air helps the living machinery in its work, making it still more effective. The outer webs of the feathers (*see* Pl. XI) are very narrow compared with the inner ones, and the result is that the air acts much more strongly upon the latter during the down-stroke and also, when there is much momentum, during the up-stroke, with the result that each feather is rotated and has the inner side of its vane pressed very closely against the one that lies next to it and above it on the side nearer to the body.

Though on the surfaces of the wing nothing is visible but feathers, yet for no small amount of the expanse two membranes can claim the credit. What is called the anterior membrane stretches from the head of the clavicle (or merrythought) to the hand (*see* fig. 24). In the Gannet it is of great breadth and is so hung that it not only increases the area of the wing, but sloping steeply downward, as it does, to form the front margin, it deepens the wing's concavity and makes it, near to the body, what a parachute should be. In most birds the membrane is slung with only a gentle slope from its front edge backward. In all it is at once stretched when the wing is spread. The other membrane lies farther

back, in the armpit, and fastens the wing to the bird's side.

It is worth while noticing that though muscles springing from the body in the main control the movements of the whole wing, yet there is a good deal of local independence. There are niceties of adjustment which depend on local muscles. Though the triceps extends the upper arm, the fore-arm and the hand, yet the two united fingers, and with them the great feathers they carry, are not under its sway but depend upon special muscles to spread them to the full and carry out minor movements. The little bastard-wing has also its own muscles—more muscles than one would expect to be at the service of so insignificant a piece of machinery.

Structure of a Flight-Feather.

For the bird flight without feathers is obviously an impossibility. If the scales of the bird's reptilian ancestors had remained mere scales, the ancestors would have remained reptiles still, condemned to crawl the earth. The scale has been glorified till it is hardly recognisable. First comes the quill with the dried remains of the pulp—the pulp that was there when it was alive and growing—still visible within it. Above is the rachis, or shaft, grooved down its front face (*see* Pls. XI and XII). From the shaft spring the barbs sloping towards the tip of the feather, from the barbs branch out the barbules or radii. From those of the barbules that are on the far side of the barb (the side farther from the base of the feather) spring the barbicels (diminutive of a diminutive !) that fasten barbule to barbule and

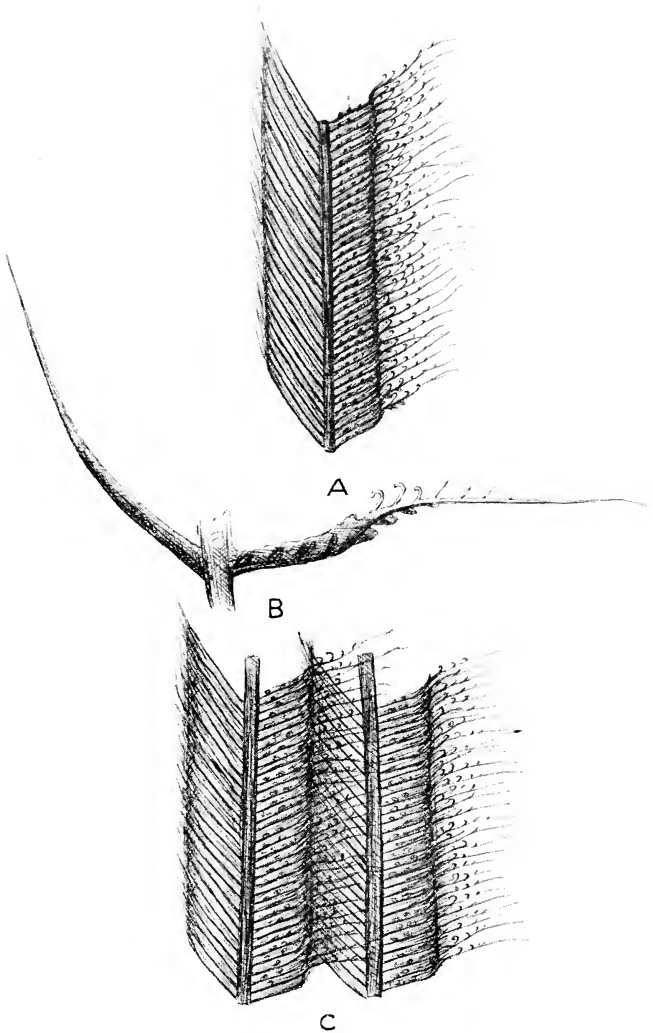

(From *Life and Evolution*.)

The barbs, barbules and barbicels of a flight-feather. A and C $\times 90$ diameters; B $\times 250$. A: A barb. C: A pair of barbs showing interlocking. B: A pair of barbules, showing the barbicels on the one nearer to the tip of the feather.

thus give the feather its elasticity, besides making it impervious to air. Compare for a moment a great flight-feather with one of those whose business is merely to clothe the bird and retain its animal heat—a poor, weak, fluffy thing. The barbicels have another name, hamuli or hooklets, from their shape. On the side of the barb which is nearer to the base of the feather, the barbules have no barbicels, but their endings resemble hairs, and these hair-like endings are neatly folded together so as to form a kind of hem. The opposite set of barbules lie over these smooth-ending ones, and among them they insert their hooklets. The hooklets slide along the barbules at moments of strain and stress, and to this, very largely, must be due the elasticity of the feather. The number of barbules is enormous; according to Dr. Gadow, over a million in one large flight-feather.

Here is another very interesting point: on the margin of the barbules opposite to that which is armed with barbicels are rough knobs. These are, I believe, the vestiges of barbicels which, being useless, are in process of disappearing. The feather is in fact thrice pinnate. The main shaft branches into barbs, the barbs into barbules, the barbules formerly branched, I believe, into barbicels on either side. But the barbules on the side nearer to the base of the feather have altogether lost their barbicels and have now only hair-like endings, while the other set have only one member of each pair properly developed, the other member being represented only by a mere vestige, so that there are only rough knobs to match the barbicels.

From whatever point of view we look at it, a flight-feather is a wonderful thing. It provides a large expanse to support the bird's weight, it is elastic, it is light and at the same time strong. Moreover, it is renewed every year, and in such a way that the bird does not even for a day lose his power of flight.

Moulting.

A living machine differs from a man-made machine in many ways, and notably in this, that it has as an indispensable characteristic, the power of self-repair. When a bird's feathers are broken or worn out, they must somehow be replaced. Now nearly all birds that fly shed their flight-feathers gradually and in pairs, so that, though during the moult they are not at their best, yet they can always rise on the wing (*see* Pl. VIII, 4). The Goose has somehow earned a widespread reputation for stupidity, but the most stupid thing that he does is not, I believe, generally known. He moults so rapidly that for a time he is reduced to helplessness. In the island of Kolguev, the Samoyeds drive thousands of moulting geese, who can only swim or run, into great nets and thus provide themselves with a store of food for the Arctic winter.

But, after all, this rapid method of moulting would involve but little danger for the Goose if man had not arrived on the scene, since his way of life became stereotyped. Many birds, not geese alone, have failed to find any means of escape from their enemy with his ever-changing method of attack. There are other birds which shed all the primary-feathers simultaneously without any disastrous consequences,

e.g. the Ducks. Mr. J. L. Bonhote has made a special study of the subject, and, quoting from him, I am able to give some very interesting and instructive facts. The simultaneous moulting of the primaries occurs among the Divers, the Guillemots, the Razorbills, the Puffins, the Auks, and besides these among the Rails, e.g. the Moor-hens, the Landrails, and the Crakes. Nearly all of them are water birds, and in the water they are fairly safe from their ordinary enemies. Some of them can dive, others can hide among reeds or under bushes; the Geese by force of numbers can, probably, beat off a bird of prey. A sea bird, if he is to moult in this fashion, must be a true diver in habit and in plumage, if not in name, and thus we find that the Cormorant (who is always wanting to dry his wings on a rock) and the Gannet moult gradually. When we turn to land birds the case of the Corncrake does not surprise us, for though he is a migrant, yet in his day-to-day life he trusts more to his legs than to his wings. The case of the Coot is perplexing; unlike the Moorhen, he is capable of flight throughout his moult; but, as Mr. Bonhote points out, he is the only member of the Rail family that frequents estuaries and open sheets of water, and he is, in addition, an indifferent diver.*

Legs.

I have already pointed out how some birds use their legs in balancing and, possibly, for steering. Indirectly the great leg-power possessed by most birds is a most important aid to flight. In order to

* See "Eclipse Plumage and Flightlessness" by J. L. Bonhote, in the *Field*, March 24, 1906.

rise with ease from the ground, they must be able first to jump into the air. Most birds have an active springing gait, and are good jumpers, their legs being built much in the same way as those of a horse or an antelope; the ankle-joint is raised high above the ground, and they walk or run upon their toes. The springiness is combined with remarkable lightness. The bird's foot is made almost entirely of skin, bone, and tendon; not like the human foot, fleshy and full of nerves. It is worked by long tendons attached to muscles that spring from the top of the leg-bone (the tibio-tarsus) or even from the base of the thigh-bone, and, running in grooves under the ankle-joint, give to the foot its springiness and to the toes their wonderful grip. The fusion of the two rows of ankle-bones with their bigger neighbours makes the ankle-joint an excellent pulley. Altogether the bird's wings have in the legs very able assistants. Comparatively few resemble the Swift in having very short and feeble legs; but, as I have pointed out above, there are a considerable number, mostly big, bulky birds, which, owing to their shortness of leg and small power of jumping, have difficulty in starting to fly from level ground.

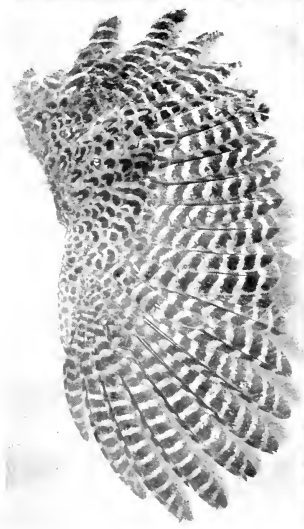

A: Wing of hen Pheasant, from above; B, from below. Actual length of wing photographed, $11\frac{2}{3}$ inches.
 C: Wing of Curlew, from below; actual length, 19 in. D: Wing of cock Sparrow-Hawk, from below;
 actual length $11\frac{2}{3}$ in. B, C, D are intended to show the amount of curve or camber, and the curved line of
 the back edge of the wing. (See Chap. VIII.)

CHAPTER VIII.

VARIETIES OF WING AND OF FLIGHT.

CURVE—NARROW AND BROAD WINGS—STYLES OF FLIGHT—
FLIGHT IN FLOCKS—THE WHIR OF WINGS.

Curve. Narrow and Broad Wings.

I shall first consider the question of curve, or, as the aviators call it, of camber—a question of the utmost importance. The wings of all birds are a good deal curved from front to back, so that as they descend they catch the air in a concavity and have plenty of lifting power. In some birds the front-to-back curve extends throughout the whole length of the wing, though in all there is some shallowing towards the tip. The Jay and the Red-legged Partridge (and their allies) supply good examples of a curve that shallows near the tip of the wing but does not disappear. In a Jay, of whose wings I made measurements, the depth of the curve—measured just on the near side of the starting-point of the bastard-wing—was 1 inch (*see* Pl. xv and also XIII and XIV). The breadth of the wing at this point was $5\frac{3}{8}$ inches. Thus the curve is 1 in $5\frac{3}{8}$, a curve such as no aviator would ever think of using. But it must be remembered that during the down-stroke it is much reduced by the pliancy of the feathers, which yield to the pressure of the air. The span

from wing-tip to wing-tip was only 18 inches. In fact it was a very short, broad, much-curved wing. The Pheasant's wing belongs to the same class; it is very short (in a hen bird of which I took measurements, only $20\frac{1}{2}$ inches); very broad (6 inches); and the curve in this particular bird was no less than $1\frac{1}{2}$ inches— $1\frac{1}{2}$ in 6! (see Pl. XIII).

The Hoopoe's wing is very much of the same build—unfortunately I cannot give exact measurements—and yet, when the season of migration comes round, many Hoopoes manage somehow to flap across the Mediterranean. As a rule migrating birds are characterized by wings of a very different make, and it sometimes happens that the wing is the feature in which they present the most striking contrast to their non-migratory kin. The clamorous Reed-Warbler, that is resident in Egypt, shows by his wings that he does not migrate—they are so very short. The migrant Reed-Warblers have decidedly longer and more pointed wings. As to the Hoopoe and its short, broad wings, it must be remembered that though it manages to cross the Mediterranean when the conditions are favourable, yet its migration flights are comparatively short. Some, I believe, do not migrate at all. If they are delayed by clouds while crossing the Mediterranean, their strength is apt to give out, whereas Herons and Swallows, to take two examples, have a reserve of vitality and will fly round a steamboat for hours, till, perhaps, the weather clears again, when with unflagging strength they will continue their journey.

To pass on to the Red-legged Partridge, I found the depth of the curve to be 1 inch, as in the Jay, but



C



D

Wings, from above. A : Gannet (actual length, 31 in.) and Montagu's Harrier. B : Of Tern and Herring Gull (actual length, 22 in.). C : Of Lapwing (actual length, 14 in.). D : Of Hoopoe (actual length, 7½ in.). (See Chap. VIII.)

the width of the wing was only $4\frac{1}{2}$ inches, whereas the Jay's was $5\frac{3}{8}$ inches wide. The wing-tip to wing-tip measurements were $18\frac{1}{8}$ inches, hardly an advance upon the Jay. It is a very short wing, and though narrower than the Jay's, it is a broad wing if we compare it with those of most birds. The Moor-hen, also, has a rounded and not very long wing, with a good deal of front-to-back curve, shallowing, however, very much near the extremity. The measurements in one specimen were: curve, $\frac{7}{16}$ inch; breadth, $4\frac{1}{8}$ inches; wing-tip to wing-tip, $21\frac{1}{2}$ inches. The breadth is very little greater than in the case of the Red-legged Partridge; in length the Moor-hen has decidedly the advantage, and the gaps between the extremities of the feathers are much less; in other words, the wing is more finished and more efficient. Here in England we look upon the Moor-hen as a stay-at-home bird, but it will cross the Alps in search of a warmer climate if need be. Frozen-out Moor-hens from northern or central Europe often accomplish this feat.

In other birds we find the curve much more reduced towards the extremity of the wing; in some it disappears almost entirely. In the Thrush the last inch and a half is nearly flat. In the Starling (Pl. xv) there are quite 3 inches with very little curve. To take a bird of larger build, the Curlew's wing (Pl. XIII) shows a great reduction of curve as soon as it begins to taper to a point; the last 4 inches are nearly flat. Moreover the curve has not the same character throughout. For a distance of some 9 inches from the body, a front margin, nearly an inch broad, is flat; behind that the downward

curve begins. Further out the whole breadth of wing is curved; for some distance from the front margin there is an upward slope, then a downward slope sets in. In the nearer region, also, there is not a simple curve maintained throughout, but the feathers in one part are more bent down than in another, so that the back edge presents a curiously undulating line. The Sparrow-Hawk's wing has similar curves, but they are much less pronounced. What the exact significance of all this complication may be, presenting so marked a contrast to the uniform curves of an aeroplane, it is difficult to say. Probably there is some significance, since in birds that are strong on the wing the whole mechanism of flight down to minute details is so efficient.

Sometimes we may see the wing-curves in their full beauty in a live bird, but it is only for a moment, and one wishes to look at them quietly and study them. The thing is, if one has a freshly-killed specimen, to cut off the wings close to the body and pin them out back downwards at their full stretch. Treated thus the wing retains its curves and a great deal of its beauty. If it is pinned face downwards and flattened, it conveys by no means so good an idea of what it was during the life of the bird. I have tried by photographs to show the outlines of various types of wing, the depth of their concavities, and the undulating curves seen in, for instance, the Curlew's wings. Some points come out distinctly, others the camera fails to see or does not see clearly.

To show the gradual tapering and flattening of the farther half, perhaps no wings are better than those of the Gannet and the Tern (Pl. XIV), and

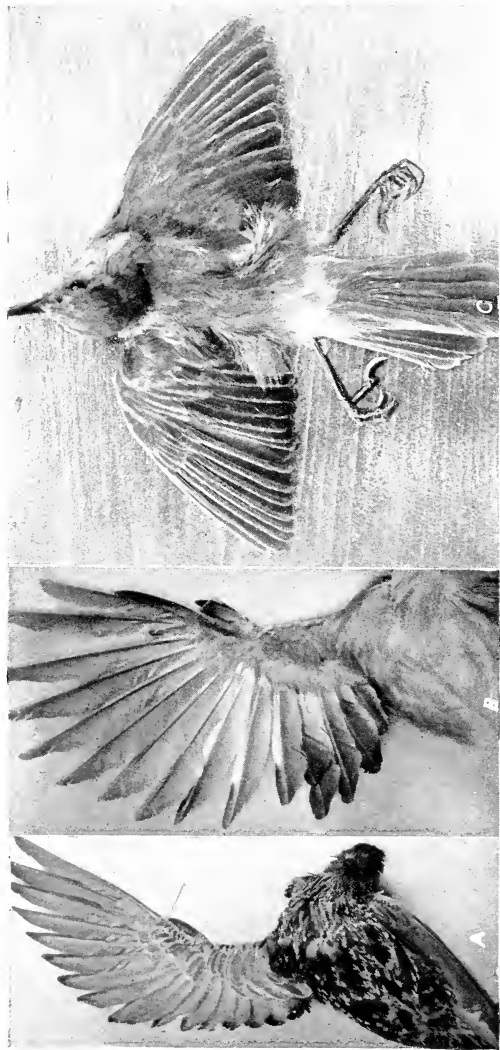

A and B: Freshly-killed birds suspended by the wing. A: Jay (actual length of wing, 9½ in.). B: Starling (actual length of wing, 7½ in.). C: *Acrocephalus stentoreus*, Clamorous Reed-Warbler (7 in. from wing-tip to wing-tip when wings are partly flexed, as in photograph). (See Chap. VIII.)

they are things of wonderful beauty. We are probably right in drawing from this flattening the inference that the swifter movement of this part of the wing makes a deep curve undesirable. The near part moves more slowly and is more parachute-like in character. The farther part, besides the momentum of the bird as a whole, has the great rapidity of stroke which sends it with a sudden dash both forward and downward. We can hardly doubt that the short, rounded wing is the primitive one. The wing of *Archæopteryx*, most ancient of known birds, did not taper to a point. And the clumsy flyers—those with rounded wings have a comparatively feeble flight—must have preceded the skilled flyers. The Hoatzin, with his very short, rounded wing, cuts a very poor figure in the air. The Hoopoe and the Jay are not strong flyers. It is not only that their wings are short and very broad: there are great interspaces, towards the hinder margin, between the feathers. This, as I have shown above, may aid automatically the maintenance of equilibrium, but the gaps are wider and deeper than are necessary for this purpose. In fact the Hoatzin's, the Jay's and the Hoopoe's wings suggest the work of a "prentice hand."

The narrow wing is certainly not primitive. I have shown above (*see* Chap. II) that most of the work is done by the front part of the wings, and this becomes increasingly true when the wing moves very much forward, cutting the air at a small angle with the horizon. This is the way in which the long wings of the best flyers cut the air. And it is in these best of flyers (I am not speaking of the Soarers)

that we find the breadth of the wing much reduced ; they taper towards the extremity where the rapidity reaches its maximum and the forward movement is greatest.

Styles of Flight.

There are two contrasted styles of flight that even the casual observer easily distinguishes. There is that of the small bird that lifts himself with two or three rapid strokes, then takes a rest and glides onwards, his wings as a rule not quite at their full span—glides so far that though his pace is considerable he loses not a little altitude. But a few strong strokes soon make this good, and he enjoys another slightly-downward glide. The Swift and the Swallow are first-rate exponents of this style, but it is common to most small birds. The Water-Ouzel is a striking exception ; his wings move so fast that you see only a blur, and he allows himself no easy intervals of gliding. Probably this is because, for his size and weight, his wings are decidedly small, so that he has to ply them unceasingly. When a larger bird flies in the dipping style—a few strokes and a glide, a few strokes and another glide—it is particularly striking. Everyone knows the dipping flight of the Woodpecker. When he glides, he flexes his wings more than most of the birds that intersperse little glides amid their flight, and so he dips more than others. Sometimes a bird whose wings are large for his size and who gains much altitude with a stroke or two, then half folds his wings, has a very butterfly-like appearance. The Wallcreeper, when he plays about a vertical face of rock in the Alps, spreading and then half flexing his

wings with their rich red coverts, looks like a butterfly, and a butterfly of marvellous beauty.

The reason that birds of larger build do not fly in this style is, probably, as I have pointed out above, that their rate of stroke being slower they lose altitude while raising their wings, unless they have considerable momentum. Their best policy, therefore, is to attain and maintain great pace, rather than to gain altitude and then indulge in a slightly downward glide. Moreover, if a big, bulky bird were to set his body at a suitable incline for rising almost vertically, as a Pigeon sometimes rises, his wings, turning stiffly as they do at the shoulder-joint, would not be able to beat in the right direction and would drive him backward rather than lift him. Some rather big birds do a good deal of gliding, but it is a very different performance from that of the small bird. They first gain altitude, not, however, by only two or three strokes, as the small bird does, but by a number. In fact they get up momentum and then are lifted, as an aeroplane set at a slight incline to the horizon is lifted when it is driven rapidly forward. They will then glide onward with wings outstretched to the full, so as to lose as little altitude as possible. A wide spread of wing is the thing needed, for, since it is the front part of the wing on which the air mainly acts, the greater the front presented the greater the supporting power. The big bird's gliding is very unlike that of the small bird that knows how easily by three or four strokes he can recover elevation, and therefore quickens his glide by the sacrifice of some of that which he has already gained. Let us take as examples of

comparatively big birds the Grouse and the Partridge. The great concavities beneath their wings, no doubt, aid them much. But the intervals of gliding, depending as they do on the preliminary attainment of great momentum, necessarily come at rarer intervals than they do in the case of the small bird. I am not speaking here of the long glides achieved without loss of altitude by some large, or fairly large, birds when the wind has an upward trend. That is a feat of the same nature as soaring, and I reserve it for another chapter.

In another way the big and the small bird present a striking contrast. The former is often the slave of his own momentum, and only with difficulty and effort deviates from his line of advance ; the Goose and the Duck are good examples of this. The Swallow, on the other hand, turns with the utmost agility and ease. Some bigger birds have a wonderful nimbleness, though, in this respect, I think, they are no match for the Swallow. The Sparrow-Hawk, as he pursues some coveted small bird, turns and twists among the trees and bushes with great skill, his long, broad tail helping him very much in steering. Birds of prey must, of course, have great nimbleness, great power of suddenly checking themselves or suddenly changing their course ; otherwise they would be unsuccessful as hunters, and would dash themselves to pieces when swooping upon some intended victim that was flying not far above the ground or a tree. The Lapwing turns to account his power of putting on the brake and making sudden turns by dashing at his enemy, alarming him, then suddenly pulling up and retreating only to make another dash. The

great breadth of his wings at their outer extremities may, as I have said, account for his well-known tactics and the skill with which he carries them out (see Pl. XIV).

The pace of the stroke varies very much in different species, a subject on which I have already said something.* A Stork goes along in very leisurely style, taking no more strokes per minute than a Heron, i.e. some 130, or even less. But one must not imagine that little force is being used. The Stork's wings are very long, and the upward bending of the primary feathers shows the great rapidity with which they are being driven through the air. It is the birds with big, long wings that have the slowest stroke. The great length of wing makes each stroke very effective, and the slow beats that we see so easily are not at all slow towards the wings' farther end. Heavy birds that have short wings have to take very rapid and very long strokes; the wing is lifted fairly high in horizontal flight, very high when they are rising, and descends till the tip has described a large segment of a circle. The Duck is a familiar instance of this style of flight. His long, strong strokes send him hurtling through the air with ponderous momentum. The same style of flight is carried to its extreme by the Guillemots, Razorbills, Puffins, and other diving birds which use their wings in swimming. It would be no good trying to fly under water with big, long wings; after the completion of a stroke, to get the wing back into position for the next would be a difficult operation. These birds, then, have the largest wings with which

* See p. 50.

it is possible for them to swim, and the smallest with which it is possible for them to fly. The wing-beats during flight are marvellously rapid ; there is visible a rapidly-moving body and a blur on either side where the wings are working with terrific speed. The Water-Ouzel searches for his food among the weeds in the bed of fast-running streams, and he, too, has short wings that he plies with very great rapidity.

The rolling flight of Partridges and Grouse is very striking. When you put them up, they never, till they have got some distance off, keep on an even keel. Probably this rolling flight makes it less easy for big birds of prey to swoop down upon them with true aim, and it may help them to glance at a pursuing enemy. In fact, the Partridge and the Grouse are still, in their habits, adapting themselves to an environment of raptorial birds rather than to an environment of sportsmen and gamekeepers. The zigzagging flight of the Snipe—a very spirited and characteristic performance—is a different thing ; the line of flight is a zigzag, but at the same time there is the rolling that we see in the Grouse's flight. It is well calculated to confuse the aim of an assailant, whether he be a bird of prey or a novice with a gun.

The way in which the long-necked and the long-legged birds carry their necks and their legs is interesting. The Duck and the Goose stretch their necks forward to their full length. This may be because the breastbone that carries the heavy flight-muscles is very long, so that the head and neck are used to balance the weight farther back. The Heron flies habitually with his neck bent—a remarkable fact

if we bear in mind that he carries his long legs stretched out behind. But his breastbone is short and deep, so that the great weight of muscle lies forward. Occasionally he may be seen to extend his neck full length, apparently for balancing purposes. The Stork is long-legged and the Flamingo still more long-legged, and both of them carry their necks and legs straight out. This is the normal attitude also of birds of prey. The Stilt, too, flies with his marvellous legs streaming out behind him ; his style of flight is well shown in a drawing in Mr. Abel Chapman's *Wild Spain*.

Flight in Flocks.

When birds fly in a flock, great or small, they often adopt a particular formation, very commonly that of a V, and this is sometimes spoken of as if it had some special merit. But really the only important thing for each bird is to keep clear of the wash of his predecessor and the broken columns of air that he leaves behind him. The force of the wash is the measure of the vigour a bird puts into his wing-strokes ; it will not do, therefore, to travel close in the wake of another bird. The bicyclist, on the other hand, breaks the resistance of the air, and the man who rides close behind another has an advantage since he finds the air more yielding. As the man in front is not riding on the air there is no back-current behind him (*see* p. 4).

The Whir of Wings.

Everyone must have noticed the different notes given out by the wings of different kinds of birds as

they fly. Very striking is the contrast between the shrill whistling of the wings of the slow-flapping Swan and the whir or swishing sound that accompanies the flight of a flock of Starlings. It has been thought that the particular note depended on the pace at which the wing moved through the air, but in reality it is due to the vibration of the feathers.

Wing music is often very beautiful ; it is a grand thing to get near to a large flock of Golden Plover and hear and see them go scudding by. There is also pleasure in watching an Owl when he comes near, and in realizing the complete silence of his flight. At the edge of the outer web of his first primary wing-feather, the hooklets of the barbules are missing, and the barbules themselves are mere vestiges. Consequently the edge of the feather has the softness of down, and this, no doubt, has much to do with the ghost-like silence of the Owl's flight. The Nightjar also is a very silent flyer, though in his wing-feathers the hooklets are nowhere missing. Still his plumage is remarkable for its softness, and this probably accounts for the absence of whir as he plies his wings.

CHAPTER IX.

PACE AND LAST.

EXPERIMENTS AND OBSERVATIONS—WIND—VELOCITY OF
MIGRATORY FLIGHTS—ENDURANCE.

Many and various are the ways that have been tried of measuring the velocity of the flight of birds, and, unfortunately, the various ways lead us to divergent conclusions. Some years ago some experiments of indisputable accuracy were made in a range constructed for experimental shooting. Two "screens" formed of very fine threads were put up at a distance of forty yards from one another. These screens were connected with electrical apparatus, by means of which the time occupied by the bird in traversing the forty yards was registered. The highest speed attained by any of the twelve Pigeons experimented on was 33·8 miles per hour, the lowest 26·1. Similar experiments have been made in the open. The velocity of four Pigeons was measured on a calm day by persons stationed at a certain distance from one another, who marked carefully the moment at which the birds came opposite to them and registered it with a stop-watch. The fastest travelled at the rate of 27·9 miles per hour. Pheasants were experimented on in the same way in the range and in the open; in the former case the velocity was 33·8, in the latter 36·1 miles per hour.

These outdoor observations may be inaccurate, but we can hardly cavil at the experiments in the shooting range.* The verdict, is, indeed, a startling one. If this is all they can do, birds have a reputation for far greater pace than is warranted by the facts. They are thought to be far swifter than the swiftest horse, but Ladas's time over the Derby course, $1\frac{1}{2}$ miles, gives him a velocity of $32\frac{1}{2}$, while Spearmint in 1906 won the Derby in 2 minutes 38.8 seconds; i.e. he maintained a speed of just over 34 miles per hour.

However, a thoroughly competent observer, Commander H. Lynes, has made similar experiments which give decidedly different results. In his observations on the *Migration of Birds in the Mediterranean* (*British Birds*, Vol. III), he writes: "The only passage speeds I was able to deal with were those of some of the species which arrived flying low. The best observations were made on the Quails by timing them from the moment they crossed the fore-and-aft line of the ship to the moment that, with a pair of glasses, they could be seen to fly into a quail-net exactly 500 yards distant. The result gave a speed of just 50 knots per hour. Corncrakes, Water-Rails and Spotted Crakes arriving appeared to be going just about the same speed, but proper time-observations of them were never obtained."

Fifty knots is just over 57 miles, a very different verdict from that pronounced on Pigeons by the experiments in the shooting-gallery and the other similar experiments in the open air. And yet the

* See Charles Lancaster's *Illustrated Treatise on the Art of Shooting*, p. 175, and Sir R. Payne-Gallwey's *Letters to Young Shooters*, p. 152.

Quail, when one sees it on migration, flying past a steamer, does not seem to be one of the fastest flyers. Unfortunately, Commander Lynes does not record any observations made on the wind at the time the Quails were flying the measured distance.

Mr. H. H. Clayton, when engaged in measuring the heights and velocities of clouds by means of special theodolites, took the opportunity of finding the pace and the height at which passing flocks of birds were flying. In one case—the birds were Ducks—he found the speed to be 47·8 miles per hour and the altitude 958 feet above the ground. Some Geese flew at 44·3 miles per hour at a height of 905 feet.* I believe Mr. Clayton gives no record of the wind.

The records of the races of Homing Pigeons give a very favourable verdict. But when the “times” have been very good, there has been in almost every case (perhaps in every case without exception) a tail-wind to help them. I take some records from the *Homing Fancier's Annual* for 1892. For 82 miles a bird maintained a velocity of just over 71 miles per hour. The weather was “splendid,” but the winner so outstripped all the others that we cannot help being slightly suspicious as to the correctness of the record. In a longer race—215½ miles, from the Scilly Isles to its home in Wiltshire—a Pigeon kept up a speed of 50½ miles per hour. In a short race—only 80 miles!—we have a velocity of 58¾ miles recorded. In a race of moderate length—170 miles—the winner travelled at the rate of just over 54 miles. There is another record of 57½ maintained for 104 miles. In all these cases, with one exception, it is recorded

* *Science*, N.S., Vol. v, No. 105, p. 26.

that there was a tail-wind to help the birds. With regard to the 80-mile race, the only meteorological note is "weather hazy." In the *Working Homer*, a high authority lays it down that a tail-wind is not absolutely essential to good "times"; what is all-essential is anticyclonic weather. A cyclone is disastrous to them. In a light breeze during an anticyclone it is recorded in this treatise that a Homing Pigeon flew from Banff to North Hants at the rate of 1,900 yards per minute, or 62 miles an hour, an astonishing pace. The author tells of a celebrated bird "Vonolel," which in two races maintained a velocity of over a mile a minute. Unfortunately he gives no record of the weather.

In France the experiment has been made of employing Swallows in place of Homing Pigeons. The idea is a very ancient one, for Pliny tells us that a certain Roman knight, who wished to let his friends at Volaterrae (in Tuscany) know who had won the chariot races, used to take with him to Rome—a distance of 130 miles—some Swallows, which he let loose after dyeing them the colour of the winner. Of the experiments in France I have not been able to obtain any accounts at first hand. One flight is reported to have been a very grand one, far surpassing anything credited to a Homing Pigeon. A Swallow was taken from Roubaix to Paris, a distance of 258 kilometres, or 160 English miles, and in 90 minutes from the time of its liberation at Paris it was back again. It had kept up a pace of 106 miles per hour!* This may seem incredible, but the

* See an article quoted from the *Globe* in the *Zoologist* for 1887, p. 397. In the *Homing News* for Sept. 13, 1889, is an account apparently of the same flight, the distance being given as 250 kilometres.

figures may possibly be correct. It must be remembered that the Swallow is better built for rapid flight than the Pigeon. Of the velocity attained by the Swift, that in his flight is very like the Swallow, but certainly more than his match, many people have arrived at an even higher estimate.

Wind.

But how are we to account for the Pigeon's comparatively very poor pace when tested in the shooting-gallery? I have shown that in most cases, when they make records, Homing Pigeons are aided by a tail-wind. Besides this it must be remembered that at a considerable altitude the air is more rarefied, and consequently offers less resistance. It is true that it gives less support. But a bird of strong flight, travelling fast, will get the support that he requires, so that he will gain and not be hindered by the rarefaction of the air. It hardly seems, however, that this can be the sole explanation, since Commander Lynes found that Quails maintained a velocity of 57 miles per hour when they had left the higher air and, on nearing a resting-place on their voyage, were flying low. Commander Lynes's observations were made, I believe, on a number of Quails under varying conditions, so that it seems probable that we have here the bird's own pace, not its pace plus that of the wind.

The difficult complication introduced by the wind has been ably dealt with by Dr. Thienemann at his post of observation not far from Rossitten, the well-known ornithological observatory on the Baltic. He has set up two lines of stakes half a kilometre

apart ; they run at right angles to the usual stream of autumn migration, which flows from NN.E. to SS.W. He takes up his position at a point in one of these lines ; at the corresponding point in the other line his assistant is stationed. With a stop-watch he marks the moment at which a bird passes his post of observation : at the moment it passes the other post, the assistant telephones the fact to Dr. Thienemann, who records it on his stop-watch. The direction of the wind is taken and the exact angle it makes with the bird's line of flight ; its pace is measured by means of an anemometer. With these data, whatever the angle may be, it is not difficult to calculate the distance travelled by the wind with the bird or in the opposite direction, while he is covering the measured half kilometre. After finding the rate at which the bird travels per second, per minute, per hour, Dr. Thienemann subtracts or adds the distance travelled by the wind, with or against, during the same time. Thus the disturbing wind-factor is eliminated and he arrives at the bird's own velocity. All this is wonderfully ingenious and wonderfully thorough ; the results have great value because they are undoubtedly dependable. We can only regret that the species of birds observed do not include any of those observed by Commander Lynes. Moreover it seems probable that they were not flying at full speed. Migration, as a rule, goes on at a great height ; these birds had descended to a low level, and with land beneath them were flying probably in leisurely style. The much greater velocity of Commander Lynes's Quails is accounted for, I believe, if we bear two facts in mind ; they are, presumably,

birds of more rapid flight, and besides this, though they had descended from their lofty heights, they were, unlike the birds at Rossitten, still straining towards the land. But in any case Dr. Thienemann's observations, in point both of method and results, are interesting and valuable. The pace of no less than twenty Grey Crows flying at different times under varying circumstances was measured, and the average velocity, after allowance had been made for the wind, was 50·04 kilometres, or 31·5 miles per hour. Two Jackdaws had an average of 39·6 miles. A Starling flew at the rate of 46·5. Six Finches averaged 33·0, two Crossbills 37·5. This is about what we should have expected. But these definite observations are much better than the shrewdest of guesses.

Velocity of Migratory Flights.

There is good reason to believe that birds while migrating attain far greater velocity than they do in their ordinary flights. Let us take an example for which there seems to be strong evidence, though it is almost too marvellous to be true. The American Golden Plovers breed in Arctic regions, from Alaska to Greenland, above the limits of forest growth, and when autumn comes they pass over Nova Scotia, strike boldly out to sea, and, generally leaving the Bermudas well to the west, sail on over the ocean till they reach the West Indies. It is difficult to believe that these are merely stray birds that have been blown out of their course and are sailing on to death. One witness after another declares that he has seen flocks of them flying southward several hundred

miles to the east of the Bermudas, on which islands they alight only if the weather is unfavourable. Flying south from the Bermudas or somewhere east of them, they must cover some 1,700 miles before they land on one of the West India islands. Either then they fly at an almost incredible pace or they remain upon the wing an almost incredible time. If this wonderful flight is really achieved by the American Golden Plover, it is certainly the most wonderful athletic feat with which birds can be credited. But there are other flights which might well strain our power of belief, if the evidence were not so strong. There are migrant birds which pass the summer (the Antipodean summer) in New Zealand, and among them are some land birds, notably two species of Cuckoo. "The long-tailed Cuckoo" (*Eudynamis taitensis*)—I quote from Mr. W. L. Buller's *Manual of the Birds of New Zealand**—"which is a native of the warm islands of the South Pacific, visits our country in the summer and breeds with us. It begins to arrive about the second week in October, but it is not numerous till the following month, when pairing commences." To get to New Zealand from New Caledonia it must pass a very wide stretch of sea, and, if it can find no small island to use as a resting-place, it must cover 1,000 miles in one flight. Since it almost certainly comes, not from Australia, but from the islands to the north-west and north of its summer home, there is little Norfolk Island or the Kermadec Islands that might be used as convenient halting-places. There is

* Buller's *Manual of New Zealand Birds*, p. 7. See Captain Hutton's *Animals of New Zealand*.

another Cuckoo (*Chrysococcyx lucidus*) called the Shining Cuckoo, which also probably follows the same route. Both of them pass over a very wide but shallow stretch of sea, from New Caledonia to New Zealand, a region that in the early Tertiary period was dry land. These birds, ultra-conservative like nearly all feathered creatures, are keeping up the practice of a great migratory flight, which, when first attempted, was an overland journey, but now passes over hundreds of miles of open sea. Captain Hutton and others who have studied New Zealand migrants are, apparently, of opinion that Norfolk Island and the Kermadecs are not used as *pieds à terre*, at any rate by all the birds that flock southward. And so they make the journey in one long flight. That the land birds ever rest on the sea is extremely unlikely, and it is, of course, impossible that they should ever get food from it. There is another bird that certainly deserves mention here—the Eastern Godwit (*Limosa baueri*). It has been found nesting in Alaska and in Northern Siberia (74°-75° N. lat.), and in August begins, in vast numbers, to move southward, passing along the coast of Formosa. It has been observed in Norfolk Island—a very interesting fact. But do all the Godwits reach New Zealand by this route? Even if they do, we must not assume that they always take a rest on Norfolk Island. It may be that they only pause there if the weather is unfavourable. It is highly probable that some migrant birds cross from Australia to New Zealand. The Australian Swallow occasionally makes its appearance there, and even if it pauses to rest on one of the Lord Howe Islands it

has still a stretch of more than 800 miles of sea to fly over. Thus the New Zealand evidence, though it is not yet as complete as we could wish, justifies us in attributing to birds quite extraordinary powers of endurance.

I have already pointed out that the rarefaction of the air at high altitudes makes it less resistant and less buoyant, an advantage without any drawback. The migrant bird flying, say, some three, four or five thousand feet above the sea level, will not suffer from the attenuation of the atmosphere, for, since he travels with very great velocity, it will give him all the support he wants. But there is another fact that must be borne in mind which may make the achievements of migrant birds more credible.

Homing Pigeons, as we have seen, make the best times as a rule when they have a tail-wind to help them. Migrant birds, on the other hand, very often have, it is said, the wind on the shoulder or blowing almost straight in their faces when they make their flights. But we must not without evidence jump to the conclusion that the wind at the altitude at which the birds are flying is blowing in the same direction as it does at our level. We have only to watch the clouds to discover that often at no very great height there is an upper current that is not following the same course as the wind below. Fifty years ago Mr. Glaisher made some investigations, by means of balloons, that threw much light on the subject. He found that, though the direction of the wind close to the earth was sometimes that of the whole mass of air up to 20,000 feet, yet at other times the direc-

tion changed no more than 500 feet up. Sometimes directly opposite currents were met with at different heights in the same ascent, and three or four streams of air were encountered moving in different directions.* But we have other more recent observations at our disposal. During the last few years the upper atmosphere has been investigated with a thoroughness never before attempted. Unfortunately most of the papers written on the subject deal more with the question of temperature than with wind direction. Often, too, they are concerned with altitudes to which no bird could possibly attain. But when we have made these deductions there still remains in the papers published by the Meteorological Society much that is of the greatest interest to the ornithologist. I single out the records of a few striking observations.

On June 23rd, 1909, kite ascents at Glossop brought out the fact that while the surface-wind was south, there was at an altitude of 2,460 feet a south-by-west current.† A great deal is to be learnt from Mr. Cave's *Pilot Balloon Observations in Barbados*, Dec. 6-11, 1909.‡ Mr. Cave found that on Dec. 8th, at an elevation of some 4,400 feet, the air-current formed an angle of 60° with the wind below. On Dec. 10th, at 6.10 a.m., at a height of 5,500 feet, there was a change in the direction of the wind amounting to 50° . When, therefore, the migrant bird may appear to have the wind on his shoulder

* See *Encyclopædia Britannica*, Vol. I, p. 267 ("Aeronautics").

† "Registering Balloon Ascents at Gloucester," June 23, 1909, by W. Marriott (Meteorological Society's Papers).

‡ Published by the Meteorological Society.

or to be facing a head-wind, he may in reality have the velocity of a tail-wind added to his own. We know as a fact that migrant birds do fly at a very great altitude. In 1880 an American ornithologist, Mr. E. D. Scott, at Princetown, New Jersey, used an astronomical telescope to watch birds passing over the disc of the moon at night. To be in focus a bird must be not less than a mile distant; it was assumed that he would not fly at a greater altitude than 10,000 feet. Knowing the angle made by the telescope with the horizon, Mr. Scott was able to calculate the lower limit; the birds were flying at a height of not less than half a mile.*

Another observer, Mr. F. M. Chapman,† also in New Jersey, made a similar use of an astronomical telescope for ornithological purposes, and watched 262 birds crossing the face of the moon. Of these 233 were calculated to be flying at a height of not less than 1,500 feet. It is remarkable that those that were at a low level were flying upward, as if they had not yet reached the stratum of air most favourable to flight. Some of the birds, as they passed over the moon's face, were silhouetted so clearly that Mr. Chapman felt confident that he succeeded in identifying the species.

Mr. F. W. Carpenter, in 1905,‡ tried a much more elaborate plan. Two telescopes, set at some distance apart—different distances were tried varying from ten to twenty-one feet—were directed upon the moon during a night in May and again during an October

* *Bulletin of Nuttall Ornithological Club*, Vol. VI.

† *The Auk*, 1888, pp. 37-39.

‡ *See The Auk*, April, 1906.

night. The eyepiece of each telescope was crossed by hairs that divided the field into "octants," and each observer had a chart of the moon divided into corresponding octants. When a bird appeared in the area covered by both telescopes, its course across the face of the moon was immediately marked on the charts by straight lines, and the hour noted. The bird, in fact, had the honour of being treated as a star; the angle at the bird subtended by the line between the two observers was calculated; a parallax was obtained, and very fairly accurate calculations were made. In May no bird was observed flying at more than 2,400 feet (less than half a mile) above the ground; the lowest was flying at a height of 1,200 feet. In October the birds ranged from 5,400 feet (over a mile) down to 1,400 feet. The calls of birds not far overhead were heard frequently during the observations, and Mr. Carpenter remarks that, probably, most flew lower than those observed through the telescopes. I don't understand this, since Mr. Carpenter says that objects as near as 1,000 feet were distinctly visible. If so, why did the low-flying birds not come into view?

It is quite possible, then, that migrant birds get much assistance from the wind. Though they often fly in such a direction that our low-level wind would strike upon their shoulder or even blow straight in their faces, yet a higher current may be shoving them onward, for they fly at an altitude up to which it frequently happens that the wind that sweeps over the earth's surface does not extend. Is it not possible that Homing Pigeons, though they fly lower

than most migrants, may sometimes get into the higher current? If occasionally they make very good times, apparently against the wind, may not the explanation be that they have got into a stratum of air that was moving in another direction? Mr. Glaisher, as I have pointed out, found that the direction of the wind sometimes changed at a height of no more than 500 feet. A Homing Pigeon, when he is starting, circles upward and takes his bearings, looking out for landmarks in the direction of the cot for which he is yearning, and it is possible that as he rises he may sometimes find a favourable breeze though the lower one is adverse. I suggest this, since a high authority on Homing Pigeons maintains that anticyclonic weather is the important thing, not the direction of the wind. Looking through the best records, however, I find that the low-level wind has been such as to propel the birds and add to their velocity. If they find themselves in a uniform horizontal current travelling in the direction in which they are travelling, there is no reason why they should be conscious of the movement of the air, unless, indeed, they mark the rapidity with which they pass their landmarks on the earth's surface and draw the inference that there is a tail-wind adding its velocity to theirs! They must, of course, fly faster than the wind, or the air will give them no support. Now, supposing their own efforts give them a velocity of 35 miles an hour and the wind has a velocity of 25, the two together make up the splendid total of 60. At present I say nothing about the question whether birds are able to fly *with* the wind when it is blowing a gale. Somehow the belief has

established itself that a bird would rather face a gale than fly before it.

Endurance.

I have already to a great extent dealt with the question of endurance. It cannot be separated from the question of pace when one is discussing the great southward flight of the American Golden Plover or the voyage of the land birds to their winter home in New Zealand, or even the flights of Homing Pigeons. In 1892 the bird that won the great race of the Manchester Flying Club from Nantes kept up a speed of $35\frac{3}{4}$ miles per hour for a distance of 430 miles. He was flying for over 12 hours, during which his flight muscles had no rest. I am assuming that he did not stop to rest. If he did stop for any length of time, his speed while he was on the wing must have been much over 35 miles. The wind was favourable, from the south-west, and the weather was fine, but this does not make the achievement a commonplace one. Another bird, when the Preston and District Homing Society had their Nantes race, flew home—a distance of 441 miles—at a rate of 36 miles per hour. A man considers 30 miles in a day a long walk. What a horse without a rider could do I don't know, but I feel sure it would be something far short of 400 miles.

In April, 1909, when I was on my way to Egypt, some Herons which were making their spring-migration flight over the Mediterranean showed astonishing endurance. When they first appeared—a flock of rather over 20—at 5.30 in the afternoon, they must already have flown at least 300 miles from the coast

of Africa. We were at the time just south of the Adriatic ; rain came on about ten in the morning, and numbers of birds, finding themselves enveloped in cloud and unable to see their way, descended to the clear air near the surface of the sea and so became visible. Throughout the day there were continually fresh arrivals. Many accompanied the ship for miles, flying round and round her, and in some cases settling and resting ; otherwise they remained continuously on the wing. When the passengers had retired to their berths the Herons were still describing circles round the ship. Next morning they were gone, and the officers who had been on duty on the bridge reported that ten of the number had flown round and round till the sun rose and then had gone off northward, having probably sighted the west end of Crete. In all they must have been at least 16 or 17 hours on the wing.

Migrant birds seem to have altogether exceptional power of endurance. Mr. J. L. Bonhote has called attention to the remarkable fact that when starting for a long voyage they are exceedingly fat, whereas they are thin when they reach their destination.* They would seem to live on their own fat, as the tadpole, when he is becoming a frog, lives by absorbing the fat in his tail. This is a very interesting fact which helps us to see how the thing is possible. But, in spite of actual or possible discoveries, the lasting power of migrant birds must always excite our wonder. Supposing that one of them takes no more than 130 strokes per minute—a very slow stroke—then, if he is on the wing 12 hours, the flight muscles

* See *Ornis*, Feb. 1909.

contract 93,600 times ! The red, stringy Depressor muscle can claim more credit for these marvellous flights than any of the others. The heart, the lungs, the whole machine, must be very strong and in perfect working order.

Sometimes birds make long flights, requiring great endurance, in the course of their day-to-day life. Of this I give an astonishing example, which is vouched for by two highly competent observers : "Another fact that well-nigh struck dumb the authors was that Ducks shot at dawn at Daimiel are found to be crop-full of rice. Now the nearest rice grounds are at Valencia, distant 180 miles ; hence these Ducks, not as a migratory effort, but merely as incidental to each night's food supply, have sped at least 360 miles between dusk and dawn"*—and, we may add, are probably ready to do it again the next day and the next. Such a trifle as 360 miles seems to put no strain on the digestive apparatus or any part of the organism. The heaviest meal is dealt with easily and causes no torpidity.

Whatever help the wind may give, it would seem to be a fair inference from the examples which I have quoted that birds surpass other animals in vitality. It is not for nothing that their normal temperature ranges in the case of some species to 111° F., and even slightly over.

* *Unexplored Spain*, p. 187, by Abel Chapman and Walter Buck.

CHAPTER X.

WIND AND FLIGHT.

RISING—FLIGHT WITH THE WIND—UNDULATING FLIGHT WITHOUT MOVEMENT OF THE WINGS—ADVANCE IN A DIRECT LINE WITHOUT MOVEMENT OF WING—ADVANCE SIDWAYS IN A DIRECT LINE—SOARING—SOARING IN A HORIZONTAL WIND IMPOSSIBLE.

No incline, however slight, escapes the notice of the bicyclist. He is as sensitive as a spirit-level. In the same way there are many birds that detect every up-current, even the most local, and make use of it, and, no doubt, detect the down-currents no less. When they have no serious business on hand they will practise manœuvres in the air, making the wind, as far as possible, do the work that would otherwise fall on their muscles. A wind with an upward trend will often lift them as if they were feathers and nothing else, provided they throw themselves into the correct attitude and hold their wings rigidly extended. Nothing but an upward-blowing wind can do the whole work of lifting, but a wind that is not of uniform velocity may be of assistance. In order to profit by the inequality, the bird must pass from a comparatively slow current of air into a comparatively rapid one. There is hardly a bird possessed of the power of flight that has not the skill to turn to account the fact that the

wind near the earth's surface increases in velocity with altitude.

Rising.

Almost everyone has noticed that birds always face the wind when they rise. In the case of big, heavy birds this is particularly striking, for they will often fly some little distance in the wrong direction, in a direction in which they certainly do not wish to go, in order to get the help of the wind in rising. When they have gained some little altitude they turn and make for their objective. When a steamer disturbs a Gannet floating on the water, if there happen to be a fresh breeze blowing from the steamer towards him, he will in rising head towards the imagined enemy, and not till he has at his disposal a few feet of altitude will he turn and make off rapidly with the wind behind him. Oystercatchers will do the same thing. Once, when walking along the sands south of the Solway Firth, I saw hundreds of them in front of me. There was a strong breeze blowing from me to them. Hence it was much easier for them to make a start if they flew towards me till they attained some slight elevation. They therefore flew a little way towards the disturber of their peace, then turned and settled some way off upon the sand. I put them up a good many times, and each time they began by flying a short distance towards me; so important is it for a bird to get the help of the wind in rising. I once saw a Cormorant fly a quarter of a mile or so in the wrong direction. He had been feeding with his fellows, which had all, after the meal, retired to a rock, where they were drying their wings in the usual

Cormorant style. There was a fresh breeze blowing from the feeding-place to the rock. As a preliminary, therefore, he flew some considerable distance in the opposite direction, then turned and joined the others.

If the wind is to help the bird to rise he must have inertia ; in other words, he must not drift with it like a balloon, but offer resistance. When he faces the wind and takes his initial jump, obviously he has inertia, for he has just left the earth, which is not moving with the wind. Facing the wind he gets it to help him. Imagine what would happen if he faced in the direction of the wind ; impinging on his back it would drive him downwards to earth again. But the assistance got from the wind does not end with the first jump into the air. The wind rapidly increases in velocity with altitude. During a terrific blizzard I once saw some Gulls with effort making headway against the blast ; they succeeded only by flying so close to the ground that their wings almost touched it. Even when there has been no gale blowing, but only a fairly stiff breeze, I have noticed that Gulls, heading against the wind, will fly as low as possible. Friction reduces the wind's velocity. Some years back some friends and I called in the help of an anemometer in order to get more definite evidence. On one occasion the anemometer recorded a velocity of 770 feet per minute at a height of 2 feet from the ground ; at $7\frac{1}{2}$ feet the velocity rose to 1,000 feet.

Here are facts of the utmost importance to bird and to aviator. We may for the sake of clearness divide the air into distinct successive streams, the second more rapid than the lowest, and each, as we

ascend, more rapid than the one below it, the rate of increase growing less as the earth is left farther and farther below. As he mounts through each successive stream of air the bird has always inertia ; he is never, like a balloon, the toy of the breeze. And this, not only because he keeps plying his wings, but because he is always emerging from a slower stream of air into a more rapid one. Consequently, quite apart from his vigorous wing-strokes, he offers resistance to the wind ; he has, in fact, the inertia that is indispensable. The force of the horizontal wind is broken up into two forces, one of which tends to lift him. The Lark, that past-master in the art of upward flight, always gets the wind to lighten the work of his wings, even up to considerable altitudes. Sometimes, when the wind fails, he will sweep vigorously round in a wide circle and make the velocity due to his own efforts to some extent take the place of a wind. Big and small alike, all birds are glad to have the help of the wind. The muscles that lift their wings are by no means strong, but as soon as they have got some way on the rush through the air does the work of lifting. A big, heavy Elevator muscle would, therefore, be a useless encumbrance during horizontal flight ; it is best to put all the strength into the Depressor. Not only is the Elevator small, but, as I have shown, it is of inferior quality ; it has not much last. All the more reason, therefore, to use artifice in order to economize effort in rising ; or, to put it more correctly perhaps, birds have not developed high-class Elevator muscles since their skill rendered them unnecessary. Big birds require the help of the wind to lift them at the

start much more than small birds. I have twice seen Snipe, if not, strictly speaking, rise, yet begin horizontal flight with the wind behind them. This shows what a good start a bird that has strong and fairly long legs gets from his first jump forward and upward from the ground. Things are very different with a Swift or a Puffin, owing to the shortness and feebleness of their legs, or such a bird as the Condor, that has no room when he is starting for the full sweep of his great wings. It is bad starters like these that are in difficulties when there is no wind to help them.*

Flight with the Wind.

I have already pointed out that Homing Pigeons make their best "times" when there is a fair breeze blowing in the direction of their flight. And for all birds that fly, not only for Pigeons, there is every reason to believe that a tail-wind means rapid travelling. But what if the wind be a gale? Somehow or other an idea has grown up that birds cannot fly, or at least do not like flying, with a gale blowing from behind them. It is curious how hard it is to get actual positive evidence for or against. Can we find competent observers who have seen birds racing before a regular gale? And who has seen anything from which we may reasonably infer that a gale from behind is an abomination to them? Some people are satisfied that they have settled this question by remarking that "it would, of course, ruffle up their feathers, and it is an undoubted fact that birds

* If there is anything of a wind, a bird, if flying with it, always wheels round and faces it when he alights, and the prudent aviator follows his example.

dislike this." By way of answer we may say that an undoubted fact is no better than blank cartridge if it does not apply to the particular case. It is true, no doubt, that whereas a horse or a cow will always turn tail to a strong breeze, a bird always stands facing it. I have just seen some forty Starlings on a dead poplar tree. All, to a bird, were facing the breeze. Gulls or Oyster-catchers may often be seen by the seashore all facing to the front like soldiers when the word "Eyes front!" is given. The nictitating membrane protects their eyes from the wind, and there is no tumbling of their neat plumage. But would such a thing be likely to happen during flight from whatever direction the wind was blowing? A bird must have some velocity of his own; he cannot be like a leaf carried by the wind; he is too heavy for such a method of travelling, and, were he to try it, he would soon descend precipitately to earth. But though he necessarily has velocity of his own added to that of the gale, it might seem possible that a terrific tail-wind might occasionally cause difficulty. Though the bird's body outpaces the gale, yet there may be moments when the gale overtakes his wings. When the down-stroke is over, the wings are moved backward as well as upward preparatory to the next stroke, though in long-distance horizontal flight the forward and backward movement is not very great. The velocity of the wind, too, varies from moment to moment, and Professor Langley showed that the greater the velocity the greater is the irregularity. Even a steady wind proves to be gusty when properly tested. If, then, the wings happened to be moving backward

just at the moment of a terrific gust, when the gale was outdoing itself, they might possibly be unable to move backward as they should. Certainly this is imaginable, though I cannot help thinking that the bird, though flustered for a moment, would cope with the difficulty. It must be remembered that it is only at slight altitudes above the earth's surface that the wind is so capricious and irregular; the obstructions it meets with there make it a broken, boisterous torrent. The migrant bird flying high above us is in a calmer stream, however rapid its onward sweep may be. What we want is positive evidence. Being in difficulties some years ago about this question, I was delighted when I came across a paper read before a learned society in Germany on this subject. The writer maintained that birds did often fly with a gale blowing from behind them, but that under these circumstances their flight is so rapid that we do not see them! And the learned society printed his paper! Commander Lynes has recorded an interesting observation that might seem to throw light upon the matter. A migrating Swallow was flying in the wrong direction, northward, when he should have been flying southward.* Apparently a gale sprang up, a gale from behind, and the Swallow in consequence, as it appeared, turned and was flying against the wind, as if intending to return to the place from which it had set out. It must not be forgotten, however, that migration, as a rule, proceeds at a great height, and that there the wind may not be blowing from the same quarter as it is at our lower level. At Alderney some years back I saw what I

* *British Birds*, Vol. III, p. 141.

attributed to unwillingness on the part of small shorebirds, Ringed Plovers and Dunlins, to fly with a gale behind them. It was a real gale. I could with difficulty make any headway when I faced it and tried to walk. The small birds kept flying from one patch of sand to another (the patches were scattered among the rocks). They never headed towards what seemed to be their objective, if, in order to reach it, they would have had to fly with the wind behind them. They would first face the wind and gain some little altitude, and then turning, so that they faced at about a right angle to it, let themselves be swept to the patch to which, apparently, they wished to go. Of this I saw a good many instances. But we cannot build much on such observations, and having since that time had occasional chances of watching similar manoeuvres in rather less violent, but still very strong winds, I am unable to draw the conclusion that I then did.

Birds are very fond of playing when upon the wing, and a good stiff breeze or a gale gives them fine opportunities. When nestlings they have very little chance of playing; they are too crowded in the nest, and in the case of many species restlessness would end in a fatal fall. But as soon as they have the use of their wings, the representatives of many species are never tired of aerial sport. No doubt this in a sense is practice. The Swallow improves in agility, and so is better able to catch gnats when he wishes to catch them. For the time he is not definitely on the hunt, but is simply enjoying the evolutions that the wind makes possible. If any one doubts this, let him watch Gulls circling by the

hour together above a cliff that gives the wind an upward incline. There are no fish to be caught there, nor anything material to be got by the performance. They are describing spirals high in air, and by their skill they get the wind to relieve them of all hard work. No wonder they enjoy it. To return to the Swallows, whose evolutions are different. When there is a fairly strong breeze blowing, the first thing is with its help to attain some altitude; they face the wind and it helps to lift them. Then, taking advantage of their position, they enjoy a variety of downward glides. Often they will face the wind and glide downward sideways, their course thus crossing the stream of the wind. If the wind has an upward trend this may be done without loss of elevation, as I hope to show later on. They can, of course, glide downward in the teeth of the wind. Sometimes they will glide sideways in the direction of the wind. In this case there are often two simultaneous movements. The bird glides downward, head leading, across the stream of the wind, but the gale sweeps him along sideways with such velocity that the other movement is obscured. I think this is the explanation of what I saw at Alderney. The birds were practising a sporting manœuvre; gaining a little elevation and then letting themselves be carried sideways by the gale.

Some aerial evolutions that I have just been watching—Swallows and one Swift were the performers—included no straight a-head flight before the wind: it was a strong wind, though not a gale. But I do not infer a positive dislike of such a thing. The manœuvres consist of varieties of tobogganing,

which familiar sport includes for human beings one thing that is not enjoyable, viz., the lugging of the toboggan to the top of the slope again. This part of the performance is laborious for the bird also, unless he can get help from the wind. This help he gets when he faces it. When he has risen high enough, he can plane down in whatever direction he may choose to go. If he chooses to go with the wind, he generally chooses the sideways method that I have described. If he were to go head leading and if his line of descent made only a slight angle with the horizontal, there would probably be a ruffling of his plumage, the thing that he abhors. It could not happen were he to take vigorous strokes, though the backward movement of the wing for the next down-stroke might imaginably, as I have shown, be a difficulty. During the Swallow manœuvres some Starlings flew past with the wind directly behind, at a considerable height, too, where the wind must have been even stronger. Their pace was no mean one, and they seemed to be suffering no kind of inconvenience. If the wind had freshened to a gale, would it have been no longer a help but a hindrance?

Since writing the above I have had a chance of watching Rooks and Starlings flying in so strong a wind that it might fairly be called a gale. The Rooks made use of up-currents and rose to a great height. Some of them flew before the wind, putting in vigorous strokes occasionally in order to outpace it. They seemed not to be in any way inconvenienced by it. Though Tennyson speaks of Rooks on a wild, windy day being "blown about the skies,"

these Rooks never for more than an occasional half-second lost command of their movements. The Starlings were no less at their ease, so that, to my thinking, this curious little problem of flight with a gale blowing from behind is settled. Birds *are* capable of such flight, and much enjoy it. But to migrate in such wild weather would be a different matter. It is no wonder that they do not choose a dark, stormy night for a long oversea voyage.

Undulating Flight without Movement of the Wings.

At one time I believed that this was possible when the wind was blowing horizontally, but I now feel sure that an upward trend is necessary. Take an example that is often to be seen. The wind is blowing at something like a right angle to the course of a steamer, and the Gulls, which are following to pick up any scraps that may be thrown into the sea, soon recognise that there is a chance of saving their muscles. There is an up-current of air on either side of the ship, for the wind is, so to speak, bent upward some little distance before it reaches the obstruction. To start with, then, the Gull obtains some slight elevation by means of a few strokes, then he glides down a gentle incline in the direction in which the ship is travelling. When close to the water he turns and faces the wind, which, having an upward trend, lifts him to the level from which he has just descended. He then glides downward again, and so the process goes merrily on.

Were the wind a horizontal one it would, no doubt, help the Gull to rise, but it would not make all

exertion on the bird's part unnecessary, any more than it does in the case of the Snipe that faces the wind in rising.

There is no reason why a bird should not advance in the same way in the teeth of a wind when the conditions are favourable, and occasionally Gulls may be seen employing this method behind a steamer when the wind is directly or almost directly ahead. As the vessel moves onward, there is a down-current behind the stern, since the air rushes down to fill the space just vacated by the advancing ship. The down-rush of air strikes the water and, rebounding

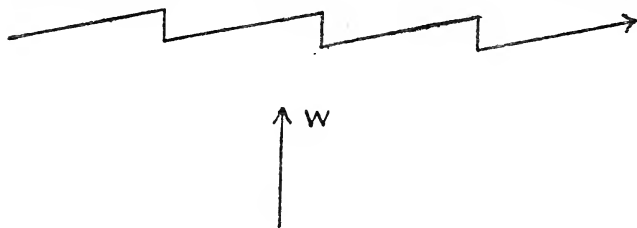

FIG. 25.

Flight at right angles to the wind, with motionless wings. W : the direction of the wind.

from it, forms an up-current a little way farther back. Here, then, is an up-current extending only over a very small area of water, but, since it moves on with the steamer, it opens up great possibilities. To start with, imagine the Gull flying a little in rear of the up-current. He glides swiftly downward and onward, and when near the water finds himself in the convenient up-draught, which lifts him to his former level, so that he is able again to glide downward and make much headway. At the end of his

glide he generally hits off the up-current, but not infrequently he fails and has to put in a few strokes. Small pieces of paper thrown over the stern show that the up-current is not always at the same distance behind the ship. Hence this method of advance, though a very gay and lively one, has, whenever I have observed it, been lacking in precision. However, when the conditions are not perfect, the Gull may be trusted to make the best of a bad job. I have just been watching some Gulls that were following a small steamer. The wind was blowing nearly at a right angle to the vessel's course. There was an up-current available, but apparently an unsatisfactory one, for there was never an advance, except for a few moments, without very distinct wing-beats. The Gulls faced the wind and, while almost uninterruptedly beating with their wings, advanced nearly sideways, right wing leading. Had there been no up-current, such a style of flight would, I believe, have been impossible. They must have been inclining their bodies slightly downwards, from the left side to the right, so as to induce movement in the direction desired. I am quite aware that birds, when they wish to advance at right angles to an ordinary horizontal wind, make a half-turn towards it, so as not to be swept out of their course. But here was an instance of a much more complete turn and an advance almost sideways.

Clever as the Gull is at such methods of advance, the Shearwater, to my mind, is a yet more perfect master of the art. He does not require any steamer to help him. If only there are waves and a wind, he has all the conditions that he wants. He keeps

gliding downward and onward till he is almost touching the water, then suddenly he faces the wind, showing his white under-surface, and is lifted a few feet, then he glides downward and onward again, again faces to right or left, and is again lifted without any sign of effort on his part. It is a weird performance, more impressive than the Gull's.

There must be up-currents when required, otherwise the Shearwater must be superior to physical laws, and such a superiority we cannot concede. The waves give to the wind the upward incline that is wanted ; even a small obstruction will cause a very considerable deflection (*see* p. 134). Advancing at something like a right angle to the wind, he feels an up-current as he is gliding downward and onward and at once turns and faces it ; thus he gains altitude and can begin another onward glide. And so he is able in most methodical style to cover large tracts of sea. Gannets may be seen employing the same method in British seas, and, no doubt, Shearwaters also, though I have seen them chiefly in the Mediterranean, where they are common. As a rule I have seen them advancing in this style at a considerable angle to the wind, but they sometimes employ the same method for an advance in the teeth of the wind. There is no reason why the Shearwater and the Gannet, having the waves and the resulting up-currents to assist them, should not do what Gulls do behind a steamer when there is a wind blowing across the vessel's course—I am speaking of the clever performance described above (*see* fig. 25, p. 131). The Shearwater and the Gannet have at

their disposal up-currents at short intervals, and these are just as serviceable to them as the travelling up-current behind a steamer is to the Gull.

Before I go further it will be best to mention some experiments I once made with a vane which, instead of swinging round to show from what point of the compass the wind was blowing, worked vertically up and down and detected up-currents and down-currents of air. For its large arm it had a thin piece of deal, one foot long by six inches broad, and this was exactly balanced by a lump of lead at the end of the shorter arm. There happened to be at New Romney, where I made these experiments, a number of banks forming barriers of a very convenient height. While standing on a bank only two feet high, its tripod lifting it four feet above the bank, the vane pointed decidedly upwards. Five yards to leeward of a bank six feet high it indicated that the wind blew downwards, making a large angle with the horizon ; there was but rarely an upward gust. Ten yards to leeward of the bank the direction was still mainly downward, but with not unfrequent upward movements. At twenty and at thirty yards' distance the wind came in wild gusts, as often upward as downward. On the windward side of the bank the results were no less remarkable. Twelve yards to windward the vane was not quite steady, but on the whole horizontal. At a distance of six yards there were occasional upward swings ; at four yards' distance there was a decided upward tendency, and this though the bank itself presented only a very gentle incline. These facts set one thinking. If a bank only six feet high is capable of so much, what

splendid up-currents must mountain ridges put at the service of a soaring Eagle!

Advance in a Direct Line Without Movement of Wing.

There is a feat perhaps more striking than any of those already described, a feat which, nevertheless, Gulls often achieve. A steamer is advancing against a fairly strong wind which, if not absolutely a head-wind, strikes the vessel at an acute angle. There results a steady up-current over the stern of the vessel, or slightly to one side or the other of the stern. Poised on this up-current the Gulls hang in mid-air, their wings held rigidly expanded. Only very slight wing-movements, evidently for purposes of balance, can be detected. Standing on the deck and watching these Gulls one is irresistibly reminded of the poising of the Kestrel high in air with wings held motionless, when he finds a wind that is all that he could wish. It is sometimes easy to forget that, unlike the Kestrel, they do not remain in one spot, but that all the while they are moving onward and, in fact, keeping pace with the steamer. The Gulls, like the Kestrel, are poising on an up-current of air, but they give their bodies a rather different incline, with the result that they keep travelling forward. The diagram will explain this. The general incline of their body and wing surfaces is slightly downwards. Hence the upward-streaming wind not only maintains them in air or lifts them higher, but, acting at a right angle, also drives them forward. Imagine a bird with his body sloped much more steeply downward. Obviously, the wind would then give him a shove forward. What the Gull does is like,

but with a difference, to a simple downward glide in still air. In the downward glide, the bird or aviator has to obtain a certain downward velocity by the help of gravity before the air will give him support. In the method of advance I have been describing no downward velocity is required, since the air has an upward trend and resists the pull of gravity. Sometimes this method of making headway without any motion of the wings may be seen in mountainous countries, where it is sometimes practised by feathered experts capable of nobler achievements

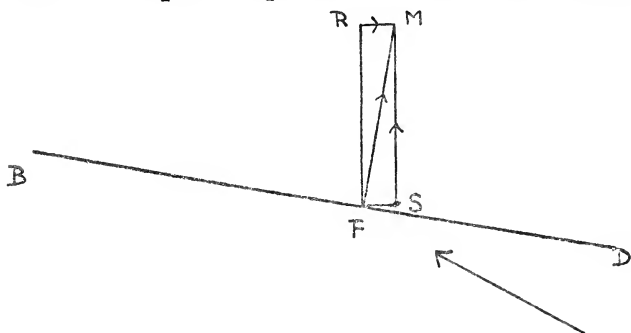

FIG. 26.

Illustrating advance, with wings held rigid, in the teeth of the wind, the wind having an upward trend. B-D, the body of the bird sloped slightly downward. The arrow represents the wind. Its force acting along F-M is broken up into two forces represented by S-M and R-M.

even than the Gull. In Algeria I once saw two Eagles sail straight ahead against the wind for about a mile and a half without moving their wings till they reached a high mountain ridge, blowing over which the wind had got an upward trend. Having done their mile and a half, they came back with the wind, beating with their wings, and then repeated their



A and B : Gulls following steamer, with motionless wings. Photographed from the stern of the ship. In A they are almost overhead. The fact that there are so many with their wings horizontal shows that it is not a case of ordinary flight. (See Chap. X.)

majestic performance, but this time at a higher level. It is not often, I believe, that there is a steady upward-trending wind extending over so long a reach. In the Alps I recently saw an Eagle perform a similar feat, but not on so grand a scale.

It is clearly possible for a bird to advance in this way facing with the wind instead of against it. The wind acts at right angles to the bird's expanse of wing and body, and, except for friction, it will not matter whether it blows from in front or behind. If it has a sufficient upward incline, it will not get between the feathers and ruffle them. But, as a fact, one very seldom sees a bird advancing in this way. Still I have occasionally met with examples, though I doubt whether the wind comes quite directly from behind; the bird turns himself just a little sideways. Circumstances are favourable when the wind blowing at a very slight angle against a cliff is deflected upward. The Gull then advances with the wind, head leading, wings motionless. But as I have said, there is, probably, always a very slight sideways turn made, so that the body from back to tail is not quite in line with the course of the wind. Is this to avoid a disarrangement of feathers—that bothersome question? Whatever the explanation of this very slight deflection, and though this method of utilising an up-current is not so common as others, yet it is important that it should obtain recognition. It will help us to understand soaring when we come to investigate that difficult subject.

The wonderful flight of the Albatross, his wings with their spread of twelve feet or more held motionless, I cannot undertake to describe, as I have never

had the luck to see it. Sometimes he seems to hang motionless over the stern of the steamer in the style with which Gulls have made us familiar. As I understand the story, the Albatross in Coleridge's famous poem was poised on an up-current above the ship's stern, presenting a big, steady target impossible to miss, when the Ancient Mariner was mean enough to shoot the unsuspecting bird. Sometimes, I am told, the Albatross sweeps majestically downward to a point some way off from the ship, his wings all the while outstretched. It seems that he must be practising the same kind of manœuvre that Gannets or Shearwaters practise, in their comparatively humble way, when they advance without a motion of their wings at right angles to the wind, or, occasionally, with the wind or against it. According to accounts, the Albatross takes downward sweeps on a gigantic scale. Those who describe it say that his evolutions carry him far away from the vessel. How, then, are we to provide him with an up-current that will lift him without his having to move his giant wings? What but the waves can deflect the wind for him, when he has planed down to regions beyond the steamer's sphere of influence? The Albatross is as completely subject to physical laws as any other bird, or as a man of twenty stone weight, and we may depend upon it that, if he is to rise in the air, it must either be by means of the contraction of muscles and powerful wing-strokes or else by the help of an ascending current of air. Those whose good fortune it is to see this noble bird at his play should watch him carefully and note all the conditions, instead of merely gazing, as many

seem to do, in open-mouthed astonishment. There is one question that, I believe, has been but little investigated. In tropical seas there may be up-currents rising from the heated surface, just as there are from sun-scorched plains even in much higher latitudes, up-currents sufficient to serve the turn of the Albatross. But his evolutions are to be seen in Antipodean regions where no such heating is likely to take place. Myself I have little doubt that the Albatross's art is only that of the Shearwater, though, owing to the great artist's enormous spread of wing, the effect produced is much grander. A writer quoted in *Flight* (Feb. 3rd, 1912) describes it thus: "The flight is generally near the water, often close to it. You lose sight of the bird as he disappears between the waves and catch him again as he rises over the crest. . . . He alters merely the angle at which his wings are inclined." Why, it is just in this style that a Shearwater sweeps downward, and then, by the help of a wave and the resultant up-current of air, regains all the altitude he has lost !

Advance Sideways in a Direct Line.

To return to the Gull, a more commonplace, yet intensely interesting subject. Often, when he wishes to advance at right angles to the wind, he faces it and travels with motionless wings sideways, or, more correctly, almost sideways. As if thinking of his objective, he inclines head and body very slightly towards it. We are, of course, presupposing an upward-trending wind ; the Gull is poised upon it. If the left wing leads, then the wind must be blowing

not exactly straight in the bird's face, but very slightly from the right. A very little shove is enough, as the air offers no great resistance to so well-built an aeroplane travelling at no more, at any rate, than twenty miles an hour, and generally slower. A man-made aeroplane is bound to move at a great pace or the air will not support it. But in the case we are considering it is the wind that must have the

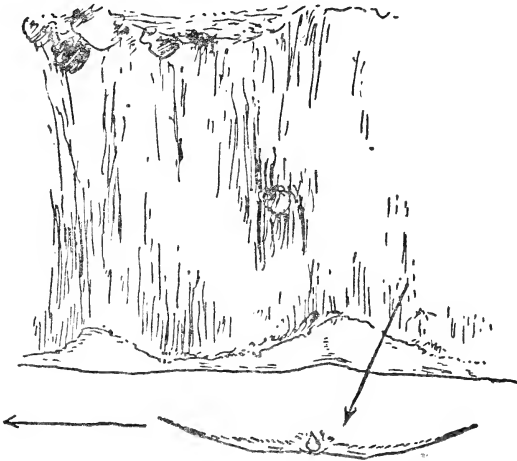

FIG. 27.

Gull gliding sideways, the left wing leading. The wind (represented by the arrow to the left) is deflected upward by the cliff.

pace. Poised upon the strong, upward stream, the Gull goes gently on his way. Some years ago, when I was at Port Erin, in the Isle of Man, it was interesting to see the Gulls returning in the evening to the little island called the Calf, at the southern

extremity of Man. The wind blowing from the west struck against the cliffs and was deflected upward. The Gulls, as they always do, saw their chance; here was a fine, effort-saving up-draught. Flying to the base of the cliff, they were lifted to the top and far above it. They would then turn and face the wind, and, with the left wing leading, return to their night quarters, their heads being inclined just a little towards the south. Occasionally Gulls adopt this method of travelling when the wind blows almost at right angles to the course of a steamer. They will hang over it and keep pace with it, their wings pointing to bows and stern. The slight adjustments that they have to make for balancing purposes are unceasing, but they are easily distinguishable from the strong wing-strokes of ordinary flight.

The two methods—advance in the teeth of the wind and advance with one wing leading—pass into one another. Obviously so, since, to get support from an upward trending wind, the Gull either faces it or much less often turns his tail towards it. Hence the necessity of progression sideways when he wishes to travel in a straight line at a right angle to the wind. When he travels at a half right angle to it, the line of advance will bisect the angle between the axis of his body and his wing. To put it less mathematically, he will be half-side face towards his line of advance.

Soaring.

Perhaps a definition of soaring may be useful. The word is used to describe the spiral ascent of a bird in the air, effected without taking any strokes

with his wings. He gets the wind to lift him, and as he rises he circles, or, more correctly, describes a spiral or helix. It is a marvellous performance. Had we not an unlimited capacity for getting used to anything, we should be lost in wonder whenever we see this splendid achievement.

Many of the larger birds are proficient at it—Eagles, Vultures, Pelicans, Storks, Falcons, Kites, Buzzards, Ravens, Gulls and others, all, even the smallest of them, possessed of wings that have a very considerable area, and are very different in outline from the long, narrow wings of the Tern or the Swift. The Gull's wing is less definitely a soaring wing than the others mentioned; adapted both for soaring and long-distance flapping flight, it is a compromise between the broad and the narrow.*

Evidently breadth, and not only length, is important in soaring, and the great primary feathers spread out, leaving very noticeable gaps between them. Probably this gives steadiness, preventing a too sudden escape of air from under one wing. If a bird is watched through a field-glass or telescope, the upward bending of these great feathers by the force of the wind is sometimes quite noticeable, the first primary being often bent considerably more than the others (*see* the Frontispiece).

It is a slow, sedate movement, this circling high in air. Mr. S. E. Peal,† who used to gaze with wonder at the circling of the Adjutants, a kind of Stork noted for their soaring, over the plain of Upper Assam, held, if I remember rightly, that the birds slept as

* See Pl. xiv.

† See *Nature*, Nov. 4, 1880; Sept. 26, 1889; May 21, 1891.

they described their sedate spirals. A bird is certainly capable of a great deal during sleep. When he sleeps standing on one leg, he is perpetually making small adjustments in order to maintain his balance. When a Duck sleeps floating on a pond with one leg tucked up, he will keep the other paddling, so that he may move in a circle and not be driven by the wind into the bank, where a hungry stoat may be waiting for him. But to sleep while soaring is an altogether different matter. The soaring bird has not only to make perpetual adjustments, but also to feel the pulse of the wind, to be alive to every gust and find out what adjustments have to be made. But the fact that so good an observer could hold this theory shows how sedate the movement is. Though the pace may vary, there is not a rapid sweep down a gentle incline in one-half of a circle, then, in the other half, when the bird has wheeled round, a slow advance with much gain of altitude : nothing corresponding to the gallop of the four-in-hand down the last fifty or hundred yards of a hill, in order that the coach's momentum may carry it some way up the hill that is immediately in prospect. The circling is slow, sedate, and apparently perfectly comfortable, and sometimes certainly the bird keeps rising through a whole turn of the spiral. He does not sweep downward in one part, then turn and gain elevation. If all goes well, if the wind is all that is required, there is no loss of altitude from beginning to end of the turn ; there may be a gain throughout.

The birds that soar are all of considerable size. Small birds, however expert in flying, are, apparently,

unable to get the wind to lift them. And yet, relatively to their bulk and weight, their wings are very decidedly larger in area than those of big birds. The explanation is, I believe, that, though the wing of the small bird is relatively the larger, yet, actually, it presents too small an expanse for the purpose of soaring. The wind, instead of giving the required support, escapes at the edges. In ordinary flight, when the beating wings move with enormous rapidity, their small area does not tell against them as it does when the bird merely remains passive and waits for the wind to strike it. In fact the velocity of the wing's movement during the down-stroke is distinctly greater than the velocity of the wind that supports the soaring bird. Even a Heron or a Crow in leisurely flight takes not less than 120 strokes per minute, the Pigeon, according to Professor Marey, 480, the Duck 540, and the Sparrow 780. This means that the farther part of the wing moves with astonishing rapidity. The big soaring bird, moreover, has a large cup-like concavity near the base of the wing, which must hold the wind and so give much support. Even the Gannet's wings, narrow and elegant as they are, have near the body a deep hollow that serves to catch and utilise any up-current that offers.

Soaring always goes on at a considerable altitude. In mountainous countries there are frequent opportunities of seeing it, and with luck one may occasionally get near to the scene of the performance. In Spain I once climbed to the top of a high cliff on which was a Vulture rookery, some fifteen nests of the Griffon Vulture, and saw the great birds circling

round a little below me. In hot countries it takes place over wide plains where there are no hills near. I have never seen or heard of it under such conditions in cold, northern regions. Nor have I seen any attempt at it over the sea. Gulls are no mean performers at soaring, and they may frequently be seen circling in fine style over cliffs. The fact that they do not soar out at sea, and that they frequently do where there are cliffs of any height, suggests the secret of the whole thing. The bird when soaring is lifted and maintained by an upward-trending wind. At sea, in our northern latitudes, there are no up-currents, or none of strength sufficient to make soaring possible. Sir Hiram Maxim is able to detect up-currents and down-currents of air that leave smooth or ruffle our comparatively cold northern seas.* It would be folly to deny their existence without very definite evidence. It is very difficult, however, to believe that they are currents of much strength. The water far away from the Tropics does not get heated sufficiently to cause a rapid upward movement of air. Were the up-currents which Sir Hiram Maxim has detected of any force and lifting power, would not the Gull and the Shearwater, quick as they are to avail themselves of any little up-draught due to steamer or to waves, hasten to make use of them? I am quite aware that I am here guilty, technically, of a *petitio principii*. I wish to show that soaring depends on up-currents of air, and I use the fact that Gulls do not soar at sea—at any rate not over our northern seas—as evidence that there are no strong up-currents. The reader

* *Artificial and Natural Flight*, p. 16.

must take the argument for what it is worth. But there is direct evidence. Aviators are now exploring the air just as birds for ages past have done, and I read in an article on military aviation* that *remous* (up and down currents of air) "are seldom met with when flying over a uniform surface such as the sea." In hot countries the air is heated by contact with the sun-baked soil. It ascends and when, at some height, it gets chilled by contact with colder air, it forms cumulus clouds. It is found that the rate at which balloons ascend varies much when there are clouds of this kind about, and that is good evidence that the air in places is streaming upward.† At a low level there are no distinct upward and downward streams, but at some height above the plains such streams begin to form and the great cumulus clouds tell us in what parts the movement is upward. One day in the Nile delta, a very hot day with a blazing sun, I was watching the Kites soaring. They were wheeling and wheeling round and not a motion of wing was to be seen. Suddenly a cloud obscured the sun, and very soon all the Kites began beating with their wings, and descended to a lower level. It may be maintained that they do not care to soar unless it is bright and sunny, and that they gave it up because, there being no longer any sunshine, they had no pleasure in continuing. Still I have seen Ravens soaring over hills in cloudy weather, and one day in the Alps, when snow or sleet fell at intervals and the wind was raw and nasty, I saw a

* By Captain Brooke-Popham, *Army Review*, Jan. 1912, p. 88.

† See "Methods for Observing Pilot Balloons," by C. J. P. Cave, *Journal of the Royal Meteorological Society*, Jan., 1910.

Kestrel hovering with motionless wings. The up-currents over sun-heated plains seem to have force up to an enormous height. In Egypt I once watched through my telescope a flock of Storks, ascending with wings held rigid till they looked mere specks. I wondered how they steered clear of one another, there were so many describing mazy, intersecting circles. It was just noon, and the day was decidedly hot.

Of course there may be among mountains upward currents that are in origin similar to those found over level plains. The extraordinary heat of the summer of 1911 has been well calculated to produce such currents in unusual places. I have a letter from Mr. R. C. Gilson that gives most striking evidence of this. "Lying on my back the other day," he writes (the letter is dated Sept. 16th, 1911, "on the summit of the Mürren Schildhorn, a flat-topped eminence (about 10,000 feet) with pretty steep sides—at all events two opposite sides are steep, the mountain is ridge-shaped—I saw a piece of paper carried up by the wind, and having no tendency to descend, but the reverse. I then noticed another much higher up, then others, an apparently indefinite series (the mountain is frequented by untidy tourists), of which the farthest that I could see were mere silvery specks in the sunshine. How high they were it is impossible to say, but I guess not far off 1,000 feet above the hill. The weather was anticyclonic, almost windless. Presumably the elevating forces were convection currents from the sun-warmed mountain-side. Where I lay I could hardly detect a breeze, but there was always a very

slight one perceptible if one approached close to the edge of the hill.”

What is going on in the air high aloft when soaring takes place over a dead level I imagine to be this. There is a wind sweeping over the plain, and at the outset it is horizontal. Coming into contact with an up-current from the heated surface below, it is deflected upward. The soaring bird, then, gets support not only from the ascending column of air, but from the wind to which the ascending column gives an upward trend. Were the heated air mounting from below the sole support, birds might soar in an almost dead calm, and that is a thing which all observers agree does not take place. They first ascend to some height—two or three hundred feet—by beating with their wings, and then the performance begins.

The reason of the spiral movement is not, I believe, far to seek. There are over the plain regions of ascending and regions of descending air. It is essential that the bird should not pass beyond the boundaries of the upward stream that maintains and lifts him. Had the wind over the whole extent of the plain an upward incline, then the Kites and the rest might soar, if the term will stand this straining of its use, in a straight line like the Eagles, whose majestic advance, without deviation to right or left, I have already described; or, to take an example more commonly seen, like the Gull that follows a steamer, poised on an up-draught over the stern. The up-and-down currents on which birds depend for soaring are sometimes very formidable to an aviator, who in a few seconds may pass through an

ascending column of air and suddenly find himself in a descending one. Captain Brooke-Popham, whom I have already quoted, says that it is probable that these *remous* seldom exceed 100 feet in width.*

In order to understand soaring, which often takes place at great heights where it is impossible, at any rate for anyone who is not an aviator, to investigate air currents, it is well to consider whether it is in principle at all different from what we may see taking place close at hand where investigation is easy. Gulls, as we know, have no difficulty, when the wind has an upward trend, in poising upon it and making headway against it. We have also seen that, the upward trend being there, they will occasionally advance, wings motionless, with the wind behind or almost behind them. When a soaring Eagle wheels round and circles, he does high aloft these two things that the Gull does near to the earth. He, of course, does something more, for when he makes a complete turn of the spiral he must, in the course of it, have the wind blowing first on one side of him and afterwards on the other. But the Gull too does something that approaches to this, for when he glides sideways he is not absolutely full face to the wind, but makes a slight turn so that it strikes him a little on one side. The soaring Eagle faces each point of the compass in turn, for he has to circle round in order not to pass beyond the limits of the upward stream of air that supports him. Let us picture him as he turns the spiral. He does not, like the earth, keep his axis pointed the same way from the beginning to the end of his orbit. As he

* *Loc. cit.*, p. 88.

revolves, he faces north, west, south, east in turn, or vice versa ; and, as he turns, the inner wing will always be rather lower than the outer one—this is with all birds the commonest way of steering. How he changes his balance is not quite clear. He may, holding his wings rigidly in a straight line, pull his body towards one wing or the other, and so weight one side more heavily than the other. More probably he bends sideways at the waist, as birds certainly do for balancing and steering purposes (*see* p. 60). Whatever the method, he has to execute slow, swaying movements with the utmost skill. Only when he travels straight for a bit will the two wings be on the same level. There is no reason why he should be in difficulties at all when the wind strikes him on the side. It will support him whichever way his head points. A glance at the frontispiece will help to make matters clear. Though the wings are held rigid, they are seldom horizontal for long together. The spiral movement demands a continual swaying of the body ; for the correct incline, not only fore and aft, but also from left to right, has to be maintained. The tail is frequently at work, and this is probably accompanied by the other movements I have just described. Otherwise the body would not swing round promptly ; the bird would not be able to describe his airy spirals. Frequently the wings are held slanting throughout the “ circle,” the inner wing pointing downwards to the centre and seeming to act as a pivot on which the bird revolves. But this is not always the case. Sometimes a bird will put in a considerable bit of straight-ahead travelling, gaining, maintaining or

losing altitude as he goes. Not unfrequently birds change from a left-handed to a right-handed spiral ; Gulls are very fond of this ; they often describe very small "circles," revolving round the downward-pointing inner-wing, and it may be that the change to the right-handed spiral saves them from giddiness.

Mr. Peal was of opinion that the Adjutants, whose soaring he studied so zealously, always made leeway as they rose. But there seems to be no reason why this should be so. It may have been that what looked like a movement to leeward had for its object the keeping within an upward slanting stream of air on which they depended. There seems no reason for an involuntary loss of leeway. Let us consider a particular turn of the spiral from start to finish. When the bird is facing the wind, he has only to incline his body correctly and he will make headway. When the wind strikes him from behind, he must slope his body downward, otherwise there will be a disarrangement of plumage, and there will result a slight loss by leeway, though no loss of elevation unless the bird so chooses. When he turns his side to the wind he is free to set himself at any incline he likes, and, according as he chooses, he will advance or retreat. During far the greater part of the circle, therefore, he is far from being the plaything of the wind. As a matter of fact birds may be seen circling over hill-tops without any loss by leeway, and I believe I have seen them equally successful over plains. There is this, too, to be remembered. When a bird has gained all the altitude he wants, by gliding slightly downward he can make headway in whatever

direction he wants, and, if there has been any loss by leeway, make it good.

Soaring in a Horizontal Wind impossible.

Given two things, a strong upward stream of air and a big bird possessed of great skill, soaring becomes quite explicable. But there are still some people, I believe, who hold that an up-current is not an indispensable condition, but that a horizontal wind is all that is needed if only the wind is not uniform, so that somehow the bird may perpetually manage to be passing from a comparatively slow current into a faster one. How such a process can be continued for an indefinite time is more than I can understand. Nevertheless some great mathematicians, who do not, however, profess to have actually watched birds soaring, maintain that it is theoretically possible. Setting aside theoretic possibilities for the moment, let us see what we can learn by observation. Wind is least uniform close to the earth, and there we find birds turning this want of uniformity to account. They face the wind as they rise and get help from it, owing to the fact that they are perpetually passing from comparatively slowly moving air into a more rapid current. But they cannot get the wind to do the whole work of lifting, whatever onward momentum they may have. They ply their wings vigorously all the time.

Evidently, then, a wind with varying velocities is not enough to account for soaring. Imagine, too, what would happen as the bird circled round. In each complete turn of the helix he must, for part of the time, have his back turned to the wind, and the

wind impinging on it—I assume the bird's body would be inclined slightly upward—would drive the bird downward, reinforcing gravitation with fatal effect. Again, it has been imagined that he is somehow perpetually passing from a slowly moving to a rapidly moving part of an eddy, a very precarious business. Even if we grant that such a method of soaring is theoretically possible, yet the stately, sedate wheeling of an Eagle shows that he is dependent on quite different conditions. He finds a strong up-current at his service, and he is securely riding upon it. Practical aviators, if they have not already done so, will be interested to read Mr. Wilbur Wright's observations on soaring birds. He has no doubt as to the necessity of an up-current. He has often watched Buzzards soaring; he calculated the upward incline of the wind where it was deflected by a hill, the hill where he and his brother were practising with their glider, and he considered the question whether he might not himself with practice learn to soar.*

And now wonderful news has come from America. Mr. Orville Wright has ascended on his glider, lifted by an up-current, and for sixty seconds has hung, almost without a quiver, in the air at a height of seventy feet over a hill-top, a truly marvellous achievement, worthy of a Kestrel.

* See "Gliding Experiments of the Wright Brothers," in the *Aero Manual*, 1910.

CHAPTER XI.

SOME ACCESSORIES.

DIGESTION—CIRCULATION, BREATHING, TEMPERATURE—REPAIR
OF THE MACHINE—CALL-NOTES AND SONG.

No one who undertook to describe a steam-engine would ever dream of omitting all mention of the furnace. To do so would be to leave out, if not the part of Hamlet, yet a most important part. I have, therefore, determined to write a short chapter on certain "accessories," which would, perhaps, be more correctly called preliminaries. These preliminaries are matters of physiology, such as feeding, digestion, breathing, regulation of temperature.

Digestion.

A bird is a glorified reptile, and one great difference between him and his cold-blooded ancestors and his cold-blooded surviving relatives also is that he needs far more fuel to keep the flame of his life burning with its normal brightness than they require to maintain their slowly smouldering fires. The bird has a huge appetite, and, except when a demand for a prolonged, uninterrupted effort is made, he craves for ample meals at no long intervals. The boa-constrictor will go a week, or, in captivity, three weeks or more without eating, even during hot weather. But such abstinence does not suit a bird.

He has a temperature considerably higher than that of a human being ; in some species it ranges up to 111° F., or even just over that. In fact his vitality is very great, and all his physiological processes are brisk and vigorous. It would not do, therefore, to economise in fuel. Though his fore limbs have been metamorphosed into wings and are incapable of doing the work of hands, his beak at the end of his long, supple neck (for it is of some length even in a comparatively short-necked bird) is quite equal to the task, and picks up big and small things easily and with skill. Moreover, birds of prey use their feet as hands, and most effectively too. As soon as he has seized his food, the bird sends it post-haste to his crop, or, if he is cropless, to his stomach, his proventriculus, to be digested. He has nothing corresponding to the apparatus that makes breathing easy for us while we chew our food. Nor has he any teeth ; powerful teeth could only exist if his jaws were strong and heavy, and it is important that his head should be light, for a heavy head would make fore-and aft balance difficult during flight. Digestion is rapid. In the case of a seed-eater, after the digestive juices have operated on the food in the proventriculus, it passes to the gizzard, to be ground up in that powerful mill. There seems to be no period of torpor after a meal as there is with a reptile, though the actual weight of what is swallowed may make flight difficult.

Circulation, Breathing, Temperature.

The heart is very efficient. Like the mammalian heart, it has four chambers, with an impassable wall

separating the two on the right from the two on the left, and the arterial blood is kept quite apart from the venous. The valve between the upper and lower chambers on the right is a single flap of muscle, very unlike the three flaps of membrane found in the mammal's heart. But it works in the same way, and is no less efficient. The blood swarms with red corpuscles, not round and without nucleus like ours, but oval and nucleated. Where they come from is a question. The marrow in human bones is believed to be a factory of red corpuscles, and so we cannot help wondering what substitute for this those birds may have whose chief bones are hollow, with only the very thinnest lining of marrow. We know that they have somewhere as good a factory as any mammal has; the richness in corpuscles banishes all doubt on this point. It may be that the spleen is very active. It is known that in mammals during the embryo stages and in after-life, in emergencies, the spleen gives birth to many red corpuscles. Whatever their origin may be, there they are in their thousands, putting vitality and energy into the bird.

The breathing apparatus is as wonderful as any part of this living flying machine. The lungs are very small and may be seen, brilliantly scarlet, neatly packed on either side of the backbone. Their efficiency is not to be measured by their very diminutive size. They have large extensions called air-sacs, into which the air rushes, passing through the lungs, when inspiration takes place. Some of the air breathed in finds its way at once into the minute air-passages that ramify about the lungs and does the work of oxidising the blood. The rest rushes straight

through large channels to the air-sacs, and, when expiration takes place, passes again, still almost fresh, to the lungs, and some of it, getting from the main passage to the little ramifications, continues the process of oxidation. Thus, if the bird takes twenty breaths in a minute, the lungs are supplied forty times with fresh air. If he has hollow bones—and in some birds almost all are hollow—pouches of pulmonary membrane extend into the cavities, and thus the bones are filled with air from the lungs (*see p. 77*).

When a bird is standing his breastbone moves with each breath; in a captive bird this is easy to see. In the case of Pelicans I have found the rate per minute to vary from 5-11, from very slow to rather slow, while in the most rapid breather, a Canary, it was not far short of 100. Between these extremes came a Blackbird with 39, a Bulbul with 48, an Ouzel with, at one time, 34, at another 50. Evidently the big bird when at rest is a slow breather; a Griffon Vulture took only nine respirations. The small birds are the more rapid, and as a rule they have a higher temperature. The Great Tit and the Swift are at one extreme with 111.2° F., and the Ostrich at the other with 99.2° . In between come the Duck with 109.1° and the Heron with 105.8° . The slow breathing of the big birds during rest is remarkable, but we cannot doubt that it becomes rapid during flight, whether the bird be big or small. Unfortunately it is very difficult to make observations, but of the method of breathing we may get some idea by watching a bird lying on his breast. When he adopts this attitude it is easy to see that his back rises with each respiration, no movement being

possible for his breast since he is resting his weight upon it. There is every reason to believe that he breathes in the same way during flight, his backbone rising and falling while his breastbone remains steady. It is difficult for the breastbone to move freely, since the pressure inwards of the wings tends to hold it fixed. Were it to move easily it would form a very unsteady pivot for the wings. The lowering of the wing helps to lift the back, for as it descends it hauls upon a muscle which passes from the upper arm-bone to the backbone, and sometimes even to the pelvis. Attempting to get direct evidence of this method of breathing, I suspended a freshly-killed pigeon by its wings and inflated its air-sacs by means of a blowing-tube inserted in the windpipe. The backbone, a little anterior to the thigh-joint, moved rather more than half an inch, the movement of the breastbone being almost too slight to measure. Of course, the conditions that obtain during flight were not reproduced; there was no pressure inwards. But the only result of such pressure would be to render the breastbone and the bones united with it still less ready to move.

The spacious air-sacs are useful not only for breathing. The bird regulates his temperature, but not by the machinery that is most effective in human beings and most mammals, for, like his reptilian ancestors, he does not perspire at any part of his surface. During hard exercise he prevents a rise to fever heat by giving off aqueous vapour from his lungs, and besides this the great amount of air that he breathes out when respiration is rapid has presumably a temperature not much below that of the

body. In other words, he is parting rapidly with caloric, and the result is that his temperature is regulated as effectively as any mammal's, though the system is in the main unlike that which operates in ourselves. All mammals, of course, throw off aqueous vapour from the lungs, but in most of them perspiration plays a very large part. Before passing on to other matters we must note that the air in pneumatic bones can be of little or no service in breathing, since it cannot be expelled at will.

Repair of the Machine.

Very often unfair comparisons are drawn between nature's machines and those which men manufacture. It is forgotten that the former have not only to do their special work, but also to keep themselves in repair; besides which they must reproduce themselves, i.e. they must be practically immortal. What a contrast to this is presented by an aeroplane which, without the constant attendance of skilled artificers, is speedily reduced to helplessness! Of the bird's stoking I have already spoken. The repairing is very wonderfully effected (*see* pp. 88, 89) without the machine having to go into hospital. The great wing-feathers on which flight depends and those in the tail also are moulted in pairs, so that, though not at his best while the process is going on, the bird is at no time incapable of flight. A few birds, as I have pointed out above, are exceptions, but under their special circumstances flightlessness, though, no doubt, an inconvenience, does not as a rule bring disaster. But for all warm-blooded beasts there is, of course, a time of helplessness when they sleep and

recuperate after the labours of the day. For most birds, however, the danger is reduced to a minimum. While they sleep perched on a branch the weight of their bodies keeps their legs bent at the ankle, and when the ankle is bent the toes grip automatically. Were it not for the automatic grip of the toes, the bird would fall and be at the mercy of any prowling enemy.

Call-notes and Song.

When the bird became able to move with speed and make long journeys, some new power was required to bring the sexes together and to prevent a pair that had mated from becoming separated. Hence it is that birds are loud-voiced, though reptiles are nearly all of them dumb. To a mere call-note, a very humble origin, it is probable that we can trace the beautiful songs of the Nightingale and the Blackcap. For many of the migrant birds in particular a loud, easily recognisable call-note was an urgent need. After a flight of some thousands of miles cock and hen must somehow find each other. The Nightingale, when he has passed the Mediterranean and reached his northern home, trumpets forth to all the world the fact that he has arrived. His future mate hears the call, and together they set about the all-important business of nesting. And thus we see that all a bird's activities must be viewed in connection with the fact that he has wings and is capable of long flights.

THE END.

INDEX.

- Adjutant Bird, 68, 142
Aero Manual, 18
Aeroplanes, 10, 12, 16, 18, 27,
36, 54, 61
Air, Rarefied, 112
— Resistance of, 2-5, 6-22, 41
Albatross, 137-139
Alighting, 64-66 (Pl. x), 124
Alix, M., 82
Angle of Incline, *see* Friction,
Gliding, Stability, Tacking
Archæopteryx, 95
Area and Cubic Content, 19, 76
Aston, Mr. W. G., 18
Avanzini, Law of, 26
Aviators, *see* Aeroplanes
- Backbone, 60, 62
Beetham, Mr. Bentley, 61, 65
Big Birds, 45, 55-58, 97, 98, 143,
144
Blood Corpuscles, 156
Bones, *see* Clavicle, etc.
— Pneumatic, 76-78
Bonhote, Mr. J. L., 89, 118
Breastbone, 67-69
Breathing, 157
Brooke-Popham, Captain, 54,
146, 149
Buller, Mr. W. L., 110
Butterfly, 19
Buzzard, 153
- Camber, *see* Curve
Carpals, 80
Carpenter, Mr. F. W., 114
Catapult (used to illustrate Glid-
ing), 26
Cave, Mr. C. J., 146
Chapman, Mr. Abel, 101, 119
— Mr. F. M., 114
Circulation of Blood, 155
- Clavicle, 69, 70
Clayton, Mr. H., 105
Cody, Mr., 61
Condor, 52
Coracoid, 69
Cormorant, 66, 121
Cubic Content and Area, 19, 76
Cuckoos in New Zealand, 110
Curlew (*see* Pl. xiii), 32, 93
Curve of Wings, 15-18
— Excessive, 25, 26
- Darwin, 52
de Lucy, M., 19
Digestion, 154
Duck, 31, 32, 53, 62, 68, 98, 119,
143
- Eagle, 57, 77, 136
Endurance, 117-119
Equilibrium (*see* Stability), 23-32
- Falcon, 68
Feathers (*see* Pls. xi and xii),
46, 84-86
— Moulting of, 88, 89
— Rotation of, 82
— Structure of, 86, 88
Feet, Use of, in Flight, 31, 32
— Structure of, 90
— Webbed, 60
Flamingo, 20, 31
Flight, Direct Advance without
Wing-strokes, 135 (Pl. xvi),
— in Flocks, 101
— Sideways, without Wing-
strokes, 139
— Styles of, 31, 96-102
— Undulating without Wing-
strokes, 130
— Velocity of, 103-117
— with the Wind, 124-130

- Flight* (Aero Weekly), 14, 16, 25
 Fowl, Jungle, 73
 Friction, 14

 Gannet (*see* Pl. xiv), 65, 76, 85,
 94, 121, 133
 Gilson, Mr. R. C., 147
 Glaisher, Mr., 112
 Gliders (*see* Aeroplanes), 25, 26,
 29, 153
 Gliding, Birds, 1-22, 96, 97
 Gnat, 19
 Godwit, Eastern, 111
 Goose, 88
 Gravity, Centre of, 23, 24
 Grouse, 73, 98, 100
 Guillemot, 68
 Gulls, 47, 60 (Pl. ix.), 77
 — Play of, 128
 — Soaring of, 145
 — Progression of, without
 Wing-strokes, 130-132, 139-
 141 (Pl. xvi)

 Hawks, 33, 74, 98
 Heart, 156
 Helmholtz, 56
 Heron, 31, 32, 50, 117
 Hoatzin, 68
 Hoopoe, 92
 Hornbill, 78
 Humerus, 71
 Hutton, Captain, 110

 Jay, 91, 93 (Pl. xv)

 Kestrel, 4, 41, 146
 Kite-flying, 9
 Kites Soaring, 146

 Lancaster, C., 104
 Langley, Prof., 12, 13, 125
 Lapwing (Pl. xiv), 32, 64, 66, 98
 Legal and Reichel, 24, 32
 Legs, Use of, in Balancing, 31,
 32, 60
 — Structure of, 90
 Lift and Drift, 1-15
 Ligament, Elastic, 82 (Pl. xi)
 Lilienthal, 16

 Lizard, 81
 Lynes, Commander, 104, 126

 Marey, Prof., 4, 5, 19, 24, 40, 43,
 50, 144
 Marriott, Mr. W., 113
 Martin, House-, 35
 Maxim, Sir H., 12, 145
 Membranes, Wing, 85
 Metacarpals, 80
 Migration, 109-117, 160
 Moor-hen, 75
 Moulting, 88, 89, 159
 Muscle, Quality of, 46, 55, 72-75,
 81
 Muscles 45, 55, 70-72
 — Weight of, 23

 Newton, Sir I., 3, 12
 Nuthatch, 65

 Ouzel, Water-, 100
 Owl, 102

 Pace, 103-117
 Parallelogram of Forces, 7
 Payne-Gallwey, Sir R., 104
 Peal, Mr. S. E., 142, 151
 Pettigrew, Prof., 119
 Pheasant, 53, 92 (Pl. xiii.)
 Pigeon (*see* Pls. ii, iii, iv, v, vi,
 viii, ix, x), 19, 32, 46, 64,
 97, 103
 — Homing, 105, 106, 117
 Pilcher, Mr., 29
 Plover, American Golden, 109
 Pressure, Centre of, 34
 Pterodactyle, 49
 Puffin, 48
 Pygostyle, 33

 Racehorse, The, 75
 Radius, 80, 82
 Rails, 89
 Raven, 146
 Reed-Warbler, Clamorous, 92
 (Pl. xv)
 Robertson, Mr. J. B., 75
 Rook, 129

- Scapula, 69
 Shearwater, 133, 134, 139
 Snipe, 130
 Soaring, 141-153
 — among Mountains, 144
 — always over Land, 145
 — over Plains, 146
 — impossible for small Birds, 143
 — impossible in horizontal wind, 152
 — spiral Movement in, 148, 151
 Sparrow-Hawk (*see* Pl. xiii), 32
 Starling, Prof., 73
 — 93 (Pl. xv)
 Stability, 23-37
 — Pendulum, 25
 Starting, 48-58 (Pl. viii), 121-124
 Steering, 59-63 (Pl. ix)
 Sternum, 67-69
 Stork, 19, 20, 101
 Surface, Area of supporting, 18-22
 Swallow, 19, 20, 98, 106, 128
 — Australian, 111
 Swift, 35, 48
- Tacking, Boat, 8, 26
 Tail, use of, in Balancing, 31-34
 — — Soaring, 150
 — — Steering, 60
 Temperature, Regulation of, 159
 Tern, 64, 94
 Thienemann, Dr., 107
- Ulna, 80
 Vane, Experiment with, 134
 Velocity, *see* Flight.
 Vertebrae, 76
 Voluntary Adjustments, 29-37
 Vulture, 144
- Weight and Supporting Surface, 19
 Wind and Flight, 107-109, 120-153
 Wind, at High Altitudes, 112-117
 — Horizontal, 130, 152
 — not Uniform in Velocity, 122-124, 125
 — having an upward Trend, 130-153
 Wing (*see* Area, Surface, Stability), Curve of, 15-18, 25, 26
 — Elasticity of, 27
 — as Lever, 38-40
 — Rotation of, 51-54
 — Shape of (*see* Pls. xiii-xv), 91-96
 — Spreading of, 81-86
 — Weight of, 75
 Wings, Whir of, 101
 Wing-strokes, Phases of (*see* Pls. iv.-vii.), 40-47, 84, 85
 — Rate of, 50, 99, 144
 — Short, 46
 — Unequal (Pl. ii), 30
 Witherby, Mr. H. F., 66
 Woodpecker, 55, 65
 Wright, Mr. Wilbur and Mr. Orville, 16, 153.

Headley, F.W. T

JUL 14 1949
AUG 9 1950

Headley, F. W.
The flight of birds. 1912/

AMNH LIBRARY



100108226

AMNH LIBRARY
100108226
Barcode
100108226