

[Faint, illegible text, possibly bleed-through from the reverse side of the page]

TABLE OF CONTENTS

| | | |
|------------|---|------------|
| 1.0 | INTRODUCTION | 1-1 |
| 1.1 | Project/Site Description | 1-1 |
| 1.2 | Site Problems and Project Objectives | 1-1 |
| 2.0 | RESPONSIBLE PARTIES | 2-1 |
| 2.1 | Contractor | 2-1 |
| 2.2 | Engineer | 2-1 |
| 2.3 | AMRB Manager | 2-1 |
| 3.0 | CONTRACT INFORMATION | 3-1 |
| 3.1 | Bidding and Pre-Construction Administration | 3-1 |
| 3.2 | Construction Administration | 3-2 |
| 3.3 | Equipment and Methods | 3-2 |
| 4.0 | COST SUMMARY | 4-1 |
| 4.1 | Summary of Pay Items | 4-1 |
| 4.2 | Job Unit Costs and Cost Comparisons | 4-2 |
| 5.0 | Project Summary | 5-1 |
| 5.1 | Site Conditions at Project Completion | 5-1 |
| 5.2 | Comments and Suggestions | 5-1 |
| 5.3 | Maintenance Follow-up | 5-2 |

LIST OF ATTACHMENTS

ATTACHMENT 1: Bid Tabulation

ATTACHMENT 2: Change Orders

ATTACHMENT 3: Payment Requests

ATTACHMENT 4: Analysis of Consultant Costs Incurred

ATTACHMENT 5: As-Built Drawings

ATTACHMENT 6: Photographs and Slides

ATTACHMENT 7: Other Project Documents

MEMORANDUM

TO : [Illegible]

FROM : [Illegible]

SUBJECT : [Illegible]

[Illegible text block]

[Illegible text block]

[Illegible text block]

[Illegible text block]

1.0 INTRODUCTION

1.1 Project/Site Description

The project area is located at the mouth of French Coulee, in the NW1/4, SE1/4, Sec 26, T19N, R6E on the Belt, MT, 7.5 minute USGS topographic quadrangle (Figure 1). It lies approximately 0.5 miles south of Belt, Montana between Anaconda Road to the southwest and the Burlington Northern Railroad tracks to the northeast. Landowners include Mayme Ballatore and Mary and Ken Martin of Belt, Beatrice MacLeod of Langly, Washington, Harriet Stanton of Tulsa, Oklahoma and the Burlington Northern Railroad.

The physiography of the Belt area is characterized by flat, benchlike uplands dissected by numerous creeks and coulees. Mississippian, Jurassic and Cretaceous sedimentary rocks are exposed in the area and are responsible for the majority of prominent landforms. The Cretaceous Kootenai sandstone serves as a caprock as well as a local and regional aquifer. The Kootenai non-conformably overlays the Jurassic Morrison Formation, the top of which contains a 4 to 15 foot zone of black, carbonaceous shale and bituminous coal (Osborne et al 1987). It is this coal seam which was mined extensively in the Belt area and French Coulee until the 1940's, at which time the demand for coal to fuel railroad engines was significantly diminished as a result of the advent of the diesel engine.

Surface water and precipitation infiltrating through soils and groundwater leaking through fractures in the overlying Kootenai into the abandoned mine workings results in the oxidation and hydrolysis of pyrite found in the coal and associated waste rock and leads to the formation of acid mine drainage (AMD).

Prior to construction, AMD from French Coulee was piped under a highway fill (MT Highway 87) and into 2 collection boxes located immediately west of Anaconda Road. From these boxes AMD entered a 6 inch clay pipe and flowed east under Anaconda Road and then north for approximately 1000 feet to a point where it discharged from the pipe into a drainage ditch and again flowed overland to the east under the BN tracks into a rip-rap ditch, joining with a much larger discharge of AMD from the old Anaconda mine and eventually flowing into Belt Creek.

1.2 Site Problems and Project Objectives

From the beginning of the project, the French Coulee Constructed Wetland was planned as an experimental project. Although wetlands have been used to treat AMD at eastern coal mines, success there has not been universal and much remains to be learned about the mechanisms and design parameters for successful application of the

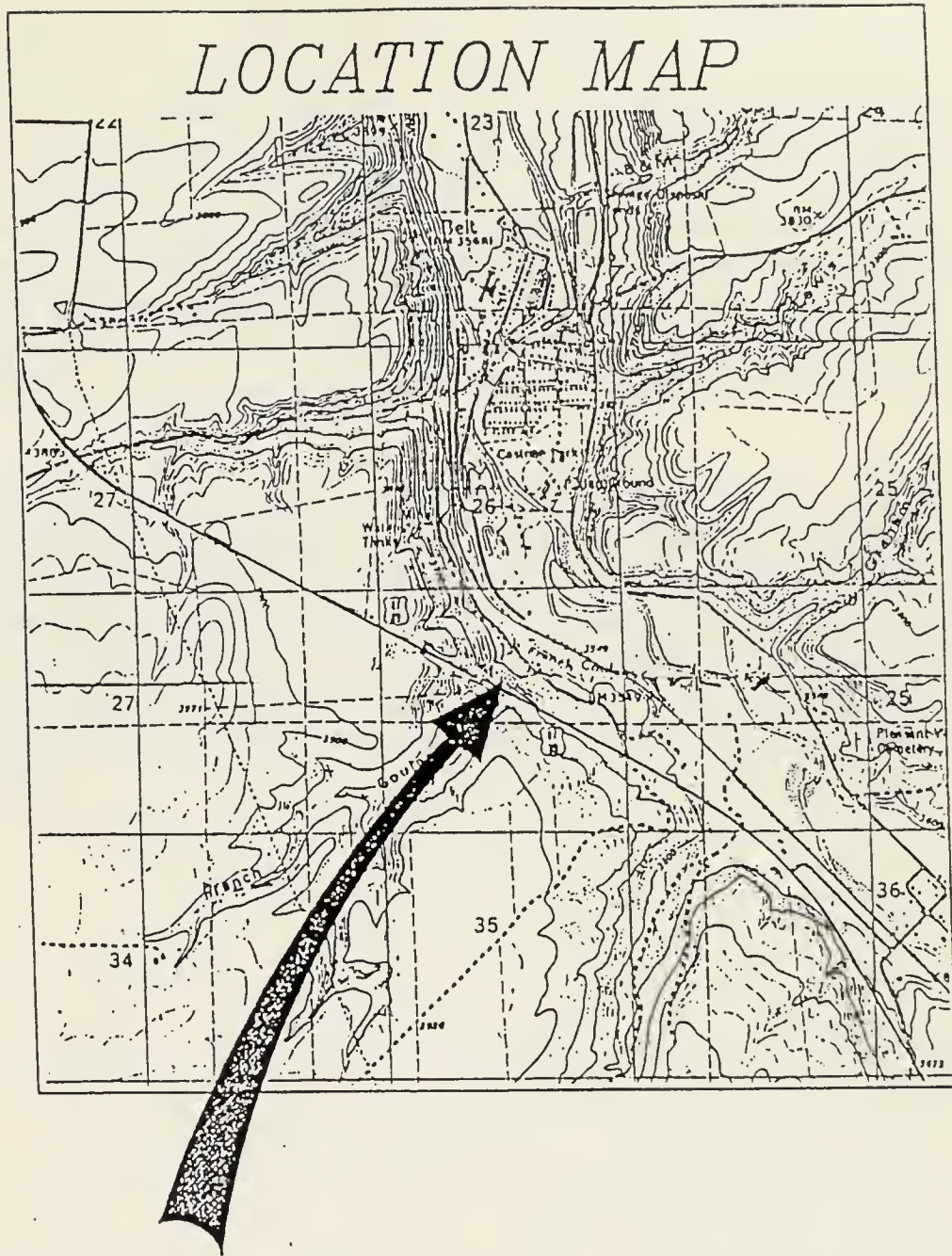

PROJECT AREA

Figure 1. French Coulee Wetland Site Location



Digitized by the Internet Archive
in 2015

<https://archive.org/details/frenchcouleecons1991scha>

technology. Sulfate reducing bacteria are believed to play an important role in removing both sulfate and dissolved metals in the form of metal sulfides. Maintenance of reducing conditions in the wetland is required for these bacteria to be active. This means an abundance of decaying organic matter must be present and oxygen should be excluded to the greatest extent possible. Application of wetland treatment technology to western sites has not been as common as it has been in the east. AMD at western sites is typically more acidic and higher in iron than that found in the east and this makes treatment more difficult. Consequently, the principal objective of the project was to provide a large scale platform to test the effectiveness of a wetland for treatment of AMD. With this in mind, the project was designed for flexibility in controlling water distribution to the treatment cells. Any cell can be operated for either upflow mode through the substrate, downflow mode through the substrate or crossflow mode over the substrate surface.

Even though the area was the subject of previous AMR work, it was still impacted by problems related to the AMD and previous mine operations. The collection boxes installed for interception and diversion of mine drainage showed evidence of periodic plugging and overflow producing burnouts on residential property. The drainage ditch leading to the culvert under the BN tracks also overflowed periodically with extensive areas of acid burnout in the area where cell 2 was located. In addition there were areas of coal spillage throughout the site which had been used for loading railcars during the era of active mining.

2.0 RESPONSIBLE PARTIES

2.1 Contractor

The prime contractor for the project was Ed Boland Construction, Inc. of Great Falls, Montana. Earthwork on the project was done by W S Repair of Great Falls as a temporary employee of Boland Construction. Formwork and concrete work was done by Tom Skovron of Great Falls, also as a temporary employee of Boland. Subcontractors to Boland were Northwest Fence of Great Falls for fencing and Western Industries of Miles City for HDPE liner and geofabric installation.

2.2 Engineer

Both design and construction supervision for the project were provided by Schafer and Associates of Bozeman, Montana. Project Manager was Ed Spotts. The responsibilities for Construction Inspector and project administration were shared jointly by Mr. Spotts and Mr. Tom Hudson.

2.3 AMRB Manager

Montana AMRB Project Manager for the French Coulee Constructed Wetland was Mr. Stu Levit.

3.0 CONTRACT INFORMATION

3.1 Bidding and Pre-Construction Administration

In January of 1990, Schafer and Associates was retained by the Montana Department of State Lands - Abandoned Mine Reclamation Bureau to design a wetland to treat acid mine drainage (AMD) emanating from abandoned coal mines in French Coulee. A bid package was prepared and advertisements were placed in major Montana newspapers for a period of three weeks by Montana DSL-AMRB. The bid period was opened on June 10, 1990 and closed on June 28, 1990. A pre-bid conference was held on June 19, 1991. Two bids were received and are shown below. A complete Bid Tabulation is provided in Attachment 1.

- | | |
|--|--|
| 1. Ed Boland Construction, Inc. Great Falls, MT. \$ 592,253.16 | 2. Schumaker Construction Great Falls, MT. \$ 689,643.63 |
|--|--|

Both bids were higher than the Engineer's estimate of \$ 409,730.00. Contractors bids were substantially higher than the engineer's estimate in the areas of sand and gravel substrate placement, soil anchor mat placement and in the some of the piping items. Boland typically was most competitive on items related to piping while Schumaker provided the most competitive bid on cell construction and material placement in the cells. This may be a reflection of the particular area of strength of each bidder. Boland does a great deal of piping contract work while Schumaker's strength is in earthwork.

There were significant variations for unit prices on some items. Schumaker was over three times as high for excavation and embankment, a lump sum item. We believe that the level of effort put forth by Boland in this area was not covered by the bid amount. Schumaker was also three times higher for the Parshall flume construction. Again, we do not feel that the bid covered Boland's costs in this area. Finally, Schumaker was substantially higher for cattail planting, Pay Item 27. This is an area in which neither bidder had much experience to draw on. Boland's bid was probably fairly close to the mark.

The bid tabulation seems to indicate that Boland put substantially more effort into the preparation of its bid. Schumaker's bid is characterized by unit costs which are round numbers. For example, unit costs between \$ 1.00 and \$ 10.00 are all in even dollar amounts and those over \$ 10.00 are rounded to the nearest \$ 5.00. Boland on the other hand appears to have worked up a unit cost for each item and carried it out to two or three significant digits. This may have allowed Boland to make a more competitive bid than Schumaker.

A contract for \$ 592,253.16 was awarded on July 5, 1990 to Boland Construction and an Agreement was executed with DSL on August 15th, 1990. A Notice to Proceed was issued on August 28, 1990 and construction start-up commenced the same day.

3.2 Construction Administration

A pre-construction meeting was held at the site on August 13th, 1990 with Barry Boland, Don Hanson and Matt Weingart of Boland Construction, Tom Hudson and Ed Spotts of Schafer and Associates and Stu Levit of AMRB in attendance. However, because of some late concerns of Mr. Frank Ballatore (on behalf of Mayme Ballatore) regarding resurveying of existing property boundaries, construction start-up was delayed until August 28th. Resurveying revealed that the existing fenceline between property owned by Mrs. Ballatore and the Martins was improperly located by approximately 40 feet, confirming the belief of all landowners involved. The survey conducted was difficult because of the lack of useable monuments but boundaries were closed with an accuracy of approximately 4 feet. The survey was recorded in the public record so that it would be of use to the public in the future.

The project benefited from exceptionally good weather which resulted in relatively few delays. Although a work stoppage was not issued, work was delayed on November 5th and 6th due to inclement weather. Work was stopped for the winter on December 14th with only a few minor tasks outstanding. This consisted primarily of completion of fencing, seeding, cattail planting, wetland flooding and tying in AMD collection points to the 8 inch main. These tasks were completed during the period of April 22, 1991 to May 9, 1991. Change Order No. 4, issued on May 22, 1991, provided for the planting of shrubs on wetland berms and other areas at the request of Stu Levit of AMRB. Because of the onset of warm weather it was deemed advisable to delay planting of shrubs until the fall. The final payment request provided funds (\$ 2,000.00) for this work. Payment was held by AMRB until completion of the work. The planting was done on October 17th and 18th, 1991.

3.3 Equipment and Methods

Construction of the French Coulee Wetland required careful sequencing of events in order that the project could be completed without delays. The sections below describe the major activities of the project and equipment used to do the work. The design of the project, utilizing three separate cells, was a distinct asset in the construction phase because it made it possible to maintain three levels of completion so that a delay on one cell would not cause the entire project to slow down.

3.3.1 Earthwork

Excavation and embankment work was done with a 5 cy Wagner scraper-hauler where there was no evidence of the presence of coal waste. Topsoil was salvaged from excavation and fill areas whenever there was no evidence of coal waste and stockpiled in separate areas according to property ownership for measurement and payment. Salvaged topsoil was used to provide for some of the project's topsoil needs although substantial additional topsoil purchases from more distant sources were required. Berms forming the cell were constructed from material excavated from the bottom of the cells and from a borrow area nearby. The borrow area identified and purchased from landowners was a knob near Anaconda Road on the property boundary between Ballatore's and Martin's. There was sufficient material on hand here to complete the earthwork. The leveling of the knob was also a major improvement to the land in that it provided more useable land for hay production and improved the view of residences across the street. An aging utility pole located on the knob was replaced by Montana Power and Light at no cost to the project.

Berms were constructed with continuous compaction provided by a Caterpillar D-4 tractor pulling a sheepsfoot. Water was applied periodically for dust control and to aid in compaction. A 1000 gallon truck with spray bar was sufficient for this task. Each load delivered by the scraper-hauler was followed by compaction with the sheepsfoot and periodic watering as required. Compaction testing by Chen-Northern verified that greater than 95 percent compaction was achieved. The D-4 was also used for initial clearing and grubbing. However, a D-7 was found to be more effective for most clearing because of its greater power and blade width.

Occasional areas of extensive coal spillage were encountered. When this occurred, the material was stockpiled for measurement and payment. The coal waste stockpile was eventually relocated next to the BN tracks between cell 2 and cell 3. In this position it provided the base for a roadway extending the full length of the project providing access for project maintenance and railroad maintenance as well.

A road grader was also operated on the site for establishment of final grades on berms and on roadways.

3.3.2 Pipe Installation

The initial trenching operation for pipe installation was for the 18 inch culvert between cells 1 and 2. This was attempted with a small Ford tractor with backhoe. However, soils in this area were cemented from years of exposure to AMD and the

backhoe was not capable of doing the job. A Caterpillar C225 trackhoe was brought to the site and this proved to be a much more capable machine, although the AMD impacted area was nearly too severely consolidated for this machine as well. The project nearly required a blasting operation in order to complete the culvert installation. Most subsequent pipe installations utilized the C225 for excavation. This included installation of 8 inch main piping, 8 inch bypass piping, manifold installations in the berms, and excavations into the berms for placement of 4 inch stubs to which the perforated piping in the cell bottoms would eventually be connected. The C225 remained on site for most of the job duration and was utilized for a wide range of other applications described below.

The selection of PVC pipe made pipe installation fast and relatively low in equipment demands. Small pipe was positioned and joined manually; pipe 8 inch and larger required the trackhoe and cable lift to aid in pipe joining. The trackhoe was used for initial excavation, placement of bedding material, and trench backfill. Rock-free bedding material was located on site and delivered as required with one of two frontend loaders on site, a Case W14 with 1-1/2 yard bucket or a John Deere JD544B tractor with a 2 yard bucket. Initial compaction of pipe installations was done with a small handheld gas engine tamper. However, the compaction needs of the project were too extensive and a Bulldog compactor was brought on the project for completion of pipe installations in trenches.

The 8 inch main was filled and pressure tested on July 2, 1991 prior to introduction of AMD to the wetland and found to have no measurable rate of leakage.

3.3.3 Soil/Bentonite Liner

Bentonite was delivered to the site in nominal 1 ton bags. Actual weight based on bills of lading averaged 2500 pounds. A 200 mesh grade was used. The bags proved to be a convenient and clean way of receiving, storing and using the product for a job of this size. The C225 backhoe was used to unload bags from the flatbed delivery trucks and again to empty bags into the hoppers of vehicles used for spreading.

Locating suitable soil for a soil/bentonite liner was a problem. No materials were available on site. The engineer's estimate and all bids were based on incorporating bentonite into the existing soils and fill material used for berm construction. However, the excavated site was completely unsuitable. Some areas were very rocky. Others were impacted by mine drainage and coal spillage. The old railroad bed was exposed in one area and at least one building foundation was unearthed. The fill material identified on site was essentially free of rocks but tested too high in calcium to be suitable without high rates of bentonite; it was also

certain to be exhausted before meeting our needs. A search was conducted for offsite soils and a large area of suitable material was identified near Highway 87 about a mile from the site. This area was cleared with the scraper-hauler and excavated with a 2 yd frontend loader. The excavated material was delivered to the site with a 12 yard dump truck.

The plan for liner construction was to spread soil material uniformly on the inside face of berms, apply bentonite, and rototill in. The cell bottom would be done last. However, an initial test of the equipment indicated that the bentonite spreader could not be maneuvered reliably even on 3:1 grades, especially with a full load. This was an especially severe problem in cell 1 which was narrow and difficult to work in. An alternative method of operation was developed in which material was mixed in the cell bottom and dozed into place on the berms. This method proved to be satisfactory although it was more difficult to produce a uniform liner thickness. In-place liner measurements varied from 6 inch thick to 11 inch thick against a target of 8 inches.

The soil delivered to the site was all taken from near the surface. Consequently, during October, the moisture content was very low. It was necessary to bring moisture content to the optimum compaction value of 16 to 18 percent prior to bentonite application. This required the use of two water trucks applying water from the top of the berm and a rototiller mixing the water in. Multiple passes were required to get uniform consistency of the wetted soil. The water trucks were 1000 and 1500 gallon capacity and equipped with two inch hoses with nozzles. The rototiller was 8 feet wide and had a maximum tilling depth of 12 inches. The rototiller was hydraulically positioned for proper depth but the tines were driven by PTO. An Allis Chalmers 7045 farm tractor was used to pull it. Water application was an expensive and time consuming operation, not fully appreciated before the job began. There were discussions about wetting the soil before excavation but it was felt this would create problems with excavation and difficulty in emptying the truck efficiently.

The 200 mesh bentonite was difficult to work with. A modified fertilizer spreader which had been used previously for bentonite application was rented by Boland Construction. The unit was equipped with a constant speed hydraulically driven apron feeder and an adjustable height gate on the discharge end. The material fed to a 1 foot diameter slinger disk which was driven by PTO from the tractor drive train. A rubber shroud 8 feet wide, 2 feet deep, 2 feet high and 6 inches off the ground was intended to contain material in order to minimize dust loss.

There were several problems with this unit. First, uniform application rates could only be achieved at constant speed. Rates were controllable only through

adjustment of the gate height and then were only valid at a specific rate of speed. This spreader was tested with fill material and this produced a uniform rate of application. On a level surface this method would probably have been workable but on sideslopes the spreader could not be pulled reliably because of poor traction. Using the bentonite material other problems surfaced as well. Dusting was severe even with the rubber shroud so that losses were significant and the dust was a potential nuisance to residents. Bridging in the hopper was also a problem. It was not possible to keep a steady flow of material to the slinger without two men with dust masks and shovels riding the hopper to assure continuous flow from the apron feeder. This method was felt to be too dangerous and inefficient to continue.

An alternative method was devised which worked reasonably well. Sufficient soil was moved into the bottom of the cell to provide liner for one or two panels of the cell liner. The necessary soil material was determined by area measurement. Loose yards to produce an 8 inch compacted liner were estimated to be that area times 11 inches thick. Soil was hauled into the cell and spread loosely with dozers to 11 inches depth in an area adjacent to the panel to be lined. The scraper-hauler was then used to spread the bentonite. A calculated number of 2500 pound bags (based on application rates for the soil developed from laboratory test data) plus 33 percent to account for inconsistencies of the spreading method and dust losses were applied to the surface of the soils. This varied from 3 bags on the end panels of cell 1 to 16 bags on the floor of cell 2. Occasionally, especially at the start of a spreading run, the scraper would apply bentonite too heavy. These areas were respread by a small dozer or raked out by hand. Once moving, though, the scraper achieved a surprisingly uniform rate of application. Two passes were necessary to spread the required quantity of bentonite over the area being treated. Although dust loss was still a factor, it was much less than with the spreader. This operation is recommended only with a very experienced operator.

The rototiller followed the spreader and tilled the bentonite into the soil. Initial passes were relatively shallow and this helped to redistribute the bentonite for even more uniform coverage. Multiple passes were required to mix the bentonite in to full depth. Complete mixing was indicated by the development of a uniform soil color. On a large area (10000 square feet or more) this took up to two hours of tilling. Occasionally, additional water would be added as the soil mix tended to dry out under such extended and vigorous mixing.

When mixing was complete dozers were used to push the soil/bentonite mix up the side of the berm panel(s) to be lined. In order to expedite this operation three dozers were often used on the larger panels. A Caterpillar D-7 and D-3 and a small Fiat-Allis dozer were available for this. Berms were staked in order to

control depth of application. This was only partially effective. There was a tendency to get especially thick application at the bottom of the berms where they met the floor of the cell.

The first attempts to compact the bentonite were with a small conventional roller. It was very difficult to operate on the 3:1 slopes with this machine. There was a lot of slipping and a tendency to create an uneven surface. Part of this was due to some overwetting of the surface. It is important to keep water trucks away from mixed material. However, even properly wetted material provides very poor traction. A Dynapac vibratory roller with tired drive wheels was brought on the job. This did an excellent job of compaction and produced a smooth finished surface. Water application was made twice daily to completed liner panels to prevent cracking until the synthetic liner was applied. Care should be exercised in water application at this stage since drainage is very poor. Synthetic liner installation is more difficult over a damp surface producing a higher rate of burnouts on seams which must then be located and repaired individually.

Following bentonite liner placement, buried stubs of the distribution piping were excavated by hand and extended into the finished cell bottom. Bentonite material was set aside and reused to fill the areas around the extended pipes.

3.3.4 Geomembrane Liner

The geomembrane liner installation was a relatively rapid process compared to the bentonite liner. An entire cell could be lined with HDPE in a single day. Geofabric liner and Enkamat erosion fabric installation took another day. HDPE was supplied in 20 foot wide rolls. A front end loader was used to bring rolls to the work area and to suspend the roll in the air for rapid unspooling of the required lengths. Sections were laid across the cells in a transverse direction. Seams were made with an electrically heated automatic seaming machine with power delivered from a portable generator. The ends of the cells tended to produce noticeable folds in the material as a result of trying to fit a flat surface onto an angular one. When these folds were large enough to suggest creasing they were cut diagonally at the corner of the cell from the top to the bottom, trimmed and seamed manually. All seams were pressure tested (the seams are made with a double weld that leaves an air pocket) to establish the integrity of the weld. Questionable welds were tested with a spark tester to locate leaks which were then repaired manually.

Boots were fabricated on site for sealing pipe penetrations. The HDPE was cut around each pipe, a boot was slipped over the pipe and welded to the liner. Silicone cement was applied liberally to the inside of the boot prior to fitting to make a seal to the pipe. Stainless steel hose clamps completed the boot

installation.

Geofabric installation was similar to the HDPE operation except that joints were sewn. Cell 1 was installed with seams up. This was satisfactory but a cleaner looking seam was made on cells 2 and 3 by seaming on the bottom side and then folding that panel down. Uneven coverage on the ends of cells was not considered to be a problem; excess material was simply folded over.

Enkamat erosion fabric was used to provide a rough surface for applied topsoil to prevent it from sloughing from sideslopes. Installation was facilitated by surveying the final substrate grade and marking this line on the geofabric. Enkamat was cut to extend past this mark into the cell by 3 feet which provided 1 foot of embedded depth. Three inches of overlap was required; sections were joined with plastic ties. All three materials were anchored in a "V" trench at the top of the berm. Tires and sandbags were used to hold liners in place until the trench could be backfilled. The Enkamat was particularly subject to damage from wind. Sandbags were applied and remained in place until substrate material placement was completed in order to keep this material in place.

3.3.5 Substrate Placement

The selection of substrate materials was altered during the course of construction to include a 12 inch lift of aged cow manure immediately above the gravel replacing part of the 18 inches of Eko-Compost originally planned in this lift. This decision was prompted by late results from column testing showing better performance in columns with readily available organic matter. Construction was somewhat more difficult in that it required proper sequencing of loads of manure and compost.

Elevations of various lifts of material were surveyed in and painted on the geofabric prior to material placement. Initial access to the cell bottom was provided by placing a small area of 1 to 3 inch gravel subbase by hand in a corner of each cell to a depth of 8 inches. A temporary ramp of Eko-Compost 1-1/2 feet thick was built down to the bottom onto this starter area. Sheets of 3/4 inch plywood were laid over the gravel in the starter area to evenly distribute the weight of equipment which would bring additional material into the cell. Two loaders were used to bring materials into the cells. Plywood was extended the entire length of the cell and moved laterally as required to provide access to new work areas. Loads were emptied and backdragged for rough spreading. Two laborers provided finished grade control with shovels and rakes. When 1 to 3 inch gravel placement was complete, 3/4 inch gravel was brought in and placed in a similar manner removing the plywood as material was placed.

When all gravel was in place, the plywood was relaid to the far end of the cell and coconut fiber mat was installed over the gravel. The C225 trackhoe was brought into the cell to assist with material spreading. This had the effect of reducing loader cycle times and the amount of manual labor for finishing. The coconut mat would be extended over the gravel to provide new work areas as required. Manure and Eko-Compost were brought into the cell alternately as needed for the first lift of organic substrate. Loaders would bring sufficient manure to provide an initial 12 inch lift. The trackhoe spread this material by swinging its bucket back and forth across the cell. Loaders dumped loads of Eko-Compost onto leveled areas of manure and this was spread by the trackhoe in a similar manner to the required depth with the assistance of manual labor for final leveling. This operation retreated to new work areas until the first substrate interval was in place over the entire cell floor. A second layer of coconut fiber mat was placed over the first substrate interval to prevent intermingling with a 6 inch sand layer above it which is intended to help redistribute water flow. The sand layer was applied with loaders and spread with the D-4. The second and final lift of substrate consisting of 18 inches of Eko-Compost was placed over the sand. This lift used the same methods of operation for material placement and spreading described above.

One particular problem was identified pertaining to the sand placement. As sand was placed, the weight of vehicles running on the plywood bringing material into the cell and the weight of the sand itself tended to compact the loose substrate below. The result was an overfilling of cell 1 and 2 with sand. Instead of getting a 6 inch thickness a 10 inch layer resulted. This was compensated for in cell 3 by overfilling the first substrate interval with four additional inches of manure (16 inches total) plus the 12 inches of Eko-Compost then compacting by running the D-7 over it before placing sand.

Large quantities of material were delivered to and stockpiled on the site. It was a constant concern to keep material of the proper kind coming so work could continue. Manure was supplied with a 12 yard dump truck and 10 yard pup trailer with 2 foot high wooden extensions for additional haul capacity. Sand and gravel were delivered in single loads in twelve yard dump trucks. Eko-Compost was delivered in 25 to 35 yard loads by either a long bed end dump trailer and truck or by a walking floor trailer and truck. The walking floor trailer carried larger loads and was easier to unload. One end dump trailer was destroyed when it tipped over on site bending the frame and aluminum box and damaging the hydraulic dump mechanism. Apparently, the back portion of the load emptied but the front portion did not, leaving the trailer top heavy and off balance.

3.3.6 Parshall Flumes

Parshall flume construction was done late in the construction sequence after installation of the liners. The HDPE liner was notched in a rectangular shape where the flume was to be located and folded back. A trench was excavated either by hand or with the assistance of the trackhoe if access permitted. Trackhoe trenching was possible on all flumes except the connecting flume between cell 1 and 2. Trenching exposed stubbed off piping which was buried in the berms to provide the required pipe connections to the flumes. Bedding material was placed in the floor of the trench and hand labor was used to trim the trench floor to the elevations required by plans.

Epoxy coated rebar was assembled and wooden forms were built around the rebar and the pipe stubs. The Parshall flumes and weir gates were positioned in the floor and walls to be cast in place. Because it was necessary to bring in imported material for bentonite liner construction after the berms were constructed, the open ends of the flumes had to be extended 2 to 3 feet longer than shown in plans in order to penetrate the completed cell. Consequently, the flumes were built to fit and dimensions vary somewhat from plans.

Concrete pouring and finishing was straightforward using sulfate resistant concrete as called for in specifications. Forms were removed after two or three days and inside surfaces were touched up for a smooth finish surface. Exposed pipe stubs were cut off and ground flush with the inside concrete wall. Inside concrete surfaces were painted with epoxy paint for improved acid resistance. Stop plates were installed over pipe openings by bolting to the walls with expansion bolts and sealed with silicone. Stainless steel screens with 1/2 inch openings were fitted over pipe openings to prevent debris from washing into the piping system. The excavation was then backfilled and the bentonite liner was replaced and compacted with a hand tamper. The HDPE liner was trimmed and refitted to the outside flume walls. Cuts at the corners were heat welded back together. The fitted liner was then sealed to the flume using neoprene rubber cement and held tightly to the wall with stainless steel battens bolted to stainless steel anchor bolts in the concrete.

3.3.7 Topsoil

Imported and salvaged topsoil was applied to all disturbed areas and to the inside of the cell berms to cover the synthetic liner according to specifications. Subsoils were scarified using a scarifier attached to the road grader prior to topsoil placement and soils were disked prior to seeding in areas where this was possible. Front end loaders delivered soil to a work area and dozers spread it to the required depth. Material placed on the inside of the cells had to be spread by hand to prevent damage to the liner by equipment.

3.3.8 Seeding

Seeding was done using a hydroseeder in two applications. The initial application consisted of the seed and a light mulch. The second application was with fertilizer and a heavy mulch. Seeding of the disturbed areas around the collection boxes was done by hand. No mulch was applied in these areas.

3.3.9 Cattail Planting and Wetland Flooding

Cattails were hand planted in a random pattern for uniform distribution. The substrate surface was raked into ridges to provide areas of high and low water which was intended to minimize short circuiting of water flow as well as providing a variety of water depths for the cattails. The cells were flooded from the bottom up using water pumped from the diversion channel and delivered to the appropriate cell by a hose. This procedure resulted in a considerable amount of floating bark chips from the Eko-Compost and the uprooting of some of the cattails especially in areas of deeper water.

3.3.10 Rip-rap

Rip-rap was placed in two locations at the site: in the stream diversion from Anaconda Road to the end of cell 3 and in the storm drainage leading to the 18 inch culvert buried in the berm between cell 1 and 2. Rip-rap was difficult to find in this area. However, a source was located on a Hutterite farm south of the project site. Rocks had been removed from the fields on this farm and were stockpiled. Rip-rap size and angularity was acceptable. Rip-rap was placed with the trackhoe. Material placed in the bottom of the stream channel was embedded using pressure on the trackhoe bucket.

3.4 Planning and Design

A number of planning and design considerations were alluded to in the discussions of paragraph 3.3. Future projects should provide for the following to facilitate smooth project execution:

- Identification and testing of soils for bentonite/soil liners before bid solicitations. The project was slowed by the sampling, testing and price negotiating for alternate soil sources.
- Consider the physical capabilities of construction equipment during design. Cell 1, which was small and narrow, was very difficult to work in. Unfortunately, it was always the first to be worked on as well which made it that much more difficult.

Construction of the larger cells seemed to go so much smoother.

- More detailed design work needed to go into the flumes, which are actually fairly complex structures to build. For example, because of the short design phase of the project vendor drawings of stop plates were not available. The use of screens for debris removal was an afterthought in the field which proved its worth when the cells were flooded.
- It may make more sense to construct the flumes prior to installation of lining materials. This was not possible in our case because we needed the plastic flumes, stop plates and weir guide inserts before concrete could be poured and these required fairly long delivery times and vendor drawing certification prior to fabrication. We simply could not delay major elements of the project waiting for these items.
- The project schedule was too optimistic. Because of the nature of the cell construction, sequencing of events was critical. Neither bidder took exception to the 60 day project completion period. However, Boland Construction did express concern over the tightness of the schedule from the first day of the project even though intending to complete it within the permitted time frame if possible. The 60 day completion period was set somewhat arbitrarily without development of a formal schedule or a critical path analysis. A short design period, which was barely adequate for completion of design drawings, probably contributed to this problem. Activities which normally depend on a complete set of drawings (bid document preparation, schedule development and cost estimate) suffered as a result.
- Pipe sizing for the 12 inch manifold appears to be too large. However, in light of the problems of screen fouling at the openings of these manifolds this oversizing may still be justified. The 8 inch main also appears to be oversized. Again, however, it may be best to wait until a maintenance history is established to determine whether a smaller pipe size is justified.
- Methods of filling cells with substrate could be more efficient, particularly on larger projects. Conveyor systems were considered by Boland but rejected. Future projects should reconsider methods for substrate placement.

4.0 COST SUMMARY

4.1 Summary of Pay Items

The final payment form, Payment Request No. 5, is included in Attachment 3. This form lists the original 43 pay items which were the basis for the bid submittals. Pay items 44 through 57 were added during the execution of the project as the result of change orders, work directives and additions to the scope of work.

Quantities used varied somewhat from original estimates. Earthwork and cell fill materials were most often subject to this. The need to go offsite for soil materials suitable for bentonite liner construction has already been mentioned. There was also a design error in cell 2 which when corrected resulted in excavation which was 1.5 feet less material than shown on the plans. This had the effect of increasing the quantity of backfill required from other sources. It also resulted in a cell floor which was wider than shown on the plans. Consequently, the quantities of fill materials were all higher than planned. Sand use was also higher than anticipated because of the compaction problem noted above. Three-quarter by one-half inch gravel usage was substantially higher than anticipated. We suspect that there was a tendency for some of this material to fill voids in the top of the 3 inch gravel on which it was placed.

One area in which quantities were lower than anticipated was in the cell liner installation. Original plans were to have this installation running up the hill on the southwest sides of cells 1 and 2. As built, the liner was terminated at an elevation from 2 to 3.5 feet higher than the top of the substrate. This was done to accommodate a temporary access road on that side of the project which was necessary for both earthwork and for cell filling.

Some items of work were eliminated or substantially reduced. Summer erosion control was never required. The lined ditch was never built. Instead, a buried 8 inch pipe was installed in the coal waste storage area to bring water from cell 2 to cell 3. This eliminated the costs for the ditch but increased the quantity of 8 inch pipe required. Much of the unlined ditch construction on the southwest of cells 1 and 2 was eliminated as well. It was felt that the areas being drained were not sufficiently large and were adequately vegetated such that runoff would not be a problem.

Change orders were generally under control on the project totalling \$ 40,165.67. The single biggest change order, Pay Item No. 45 for \$ 19,600.00, was for the supply of offsite soils for bentonite liner. This accounted for about one-half of the total change orders. Some change orders were at the direction of AMRB. These included Pay Items 47, 48, and 56. Most of the other change orders are related to details of flume construction and piping. We felt that drawings and plans for these items were not sufficiently clear to define exactly what was required of the contractor.

4.2 Job Unit Costs and Cost Comparisons

Unit costs for this project can be found in the final pay request in Attachment 1. However, as noted earlier some items varied substantially between the two bids submitted so it would be advisable to take this into account if these unit costs are to be used for estimating future jobs.

Useful measures of comparative costs for this project are not easily defined. One must bear in mind that the site was constructed as an experimental testbed and this resulted in a more complex design than might otherwise be the case. The following capital cost ratios, based on 15 gpm design flow rate, 700 ppm iron content, 1.52 acres of treatment area and an estimated 20 year useful life, may provide a guide for future projects of this type:

| | | |
|---|----|------------|
| Cost per gpm of mine drainage treated: | \$ | 45,000.00 |
| Cost per K gallon of mine drainage, 20 year life: | \$ | 4.30 |
| Cost per pound of Fe removed annually: | \$ | 14.00 |
| Cost per pound of Fe removed, 20 year life: | \$ | 0.70 |
| Cost per acre of wetland treatment area: | \$ | 445,000.00 |

Initially defined pay items (1 through 43) were brought in at \$ 637,221.81 or 7.6 percent over original plan. Change orders on the project were \$ 40,165.67 or 6.8 percent above original plan.

A summary of the design costs and construction supervision costs is found in Attachment 4.

5.0 PROJECT SUMMARY

5.1 Site Conditions at Project Completion

In mid-July, 1991, water from the two intercepted sources was being successfully treated at an influent rate of approximately 14 gpm producing effluent at pH 7. Discharge from cells 1 and 2 was running decidedly acid (pH 3), however. Initial analytical results indicated that the first two cells were functioning primarily for metal removal and doing an effective job at this.

Cattails were established in all of the cells but were flourishing best in cell 3. Aquatic organisms were observed in all of the cells but only in cell 3 was a diverse culture apparent. During the summer hundreds of dragon flies and damsel flies inhabited the area; several different species were noted. Killdeer were seen around cell 3 though it was not established whether they had successfully nested there. One duck was observed on cell 3. Birds seemed to avoid the more acidic areas of cells 1 and 2.

The seeding produced an abundance of wild mustard. Apparently this was brought in with the topsoil. The mustard was cut down before going to seed. There was some debate whether this was appropriate action. Some felt that the mustard would be a beneficial nurse crop for germinating grasses and would best be left in place. Ultimately the grasses should dominate again.

There was some problem with plugging of screens with floating debris. This may be only an initial problem which will subside with time or it may require either a permanent remedy or a maintenance program to keep screens clean.

In general, the overall appearance of the area was much improved. As-built drawings of the project are provided in Attachment 5.

5.2 Comments and Suggestions

Most of the problems on the job were related to inadequate or insufficient information in design documents. In particular, definition of soil sources, flume details and piping details were not entirely adequate. As noted earlier, this was due to a very short design schedule. Nonetheless, these problems were not beyond resolution in the field and did not result in major cost impacts on the project. Additional design work would probably not have resulted in substantially lower project costs but could have produced a somewhat shorter construction schedule, a more accurate project cost estimate and fewer change orders.

One design improvement has been identified now that the cells have been flooded and are operational. All flumes are sloped to provide for drainage away from the Parshall flume inserts. However, because there is a two inch lip on the stopplate frames, and because of the tendency for screens to plug, the slope provided is not sufficient to prevent flooding of the flume inserts. Thus, meaningful flow data are difficult to obtain. These measurements can be made at the inlet of all three cells by lifting the downstream weirs and allowing the flume to discharge to the surface of the cell until a reading is made. On the discharge flumes from cells 2 and 3 this technique cannot be used. These flumes cannot be used for measurement as installed. Future designs should provide for additional slope or a depressed drainage box to provide better drainage in the area of the Parshall insert.

5.3 Maintenance Follow-up

A program of regular sampling is being conducted to gather data on the wetland performance. This should ultimately include sampling of substrate material to determine mechanisms of metal removal. This sampling program together with operating and maintenance requirements was described in an Operating and Maintenance Plan submitted to AMRB on September 16, 1991.

It is too early to assess the need for action to deal with the observed problem of screen plugging. This problem may subside with continued use. Possible remedies, should the problem persist, include the following:

- Removal of screens when floating debris subsides,
- Operation of the cells in downflow mode which will cause the substrate to act as a filter media,
- Modification of flume inlets to provide for effective screening there rather than at the inlets to pipe openings,
- Installation of flume covers to prevent wind blown debris from collecting in the flumes. This may also be beneficial if winter operations indicate a problem with ice formation, and
- Initiation of a permanent maintenance program to inspect and clean flume structures on a regular basis.

ATTACHMENT 1
BID TABULATION

**FRENCH COULEE WETLAND
ENGINEER'S ESTIMATE**

| ESTIMATED QUANTITY | UNITS | ITEM DESCRIPTION | UNIT PRICE | TOTAL PRICE |
|--------------------|----------|--------------------------------|------------|-------------|
| 1 | LUMP SUM | MOBILIZATION | XXXXX | 30,000.00 |
| 1 | LUMP SUM | DEBRIS REMOVAL | XXXXX | 2,000.00 |
| 5,060 | BCY | EXCAVATION AND EMBANKMENT | 2.40 | 12,144.00 |
| 5,820 | BCY | PROVIDE BACKFILL | 3.00 | 17,460.00 |
| 2,840 | BCY | HAUL | 1.40 | 3,976.00 |
| 1,165 | BCY | PROVIDE TOPSOIL | 7.00 | 8,155.00 |
| 89,550 | SF | SOIL-CLAY LINER | 0.30 | 26,865.00 |
| 103,650 | SF | GEOMEMBRANE LINER | 0.55 | 57,007.50 |
| 103,650 | SF | PROTECTIVE GEOFABRIC | 0.20 | 20,730.00 |
| 86,900 | SF | UNDERLAYMENT FABRIC | 0.21 | 18,249.00 |
| 44,300 | SF | SOIL ANCHOR MAT | 0.25 | 11,075.00 |
| 690 | CY | 1.5/3 INCH GRAVEL | 5.00 | 3,450.00 |
| 365 | CY | 0.5/0.75 INCH GRAVEL | 5.00 | 1,825.00 |
| 4,460 | CY | ORGANIC SUBSTRATE | 24.00 | 107,040.00 |
| 740 | CY | SAND SUBSTRATE | 5.00 | 3,700.00 |
| 5 | EACH | PARSHALL FLUME | 2,000.00 | 10,000.00 |
| 2,590 | LF | 8 IN PVC (MAIN/BY-PASS) | 4.00 | 10,360.00 |
| 200 | LF | 12 IN PVC (MANIFOLD) | 20.00 | 4,000.00 |
| 200 | LF | 6 IN PVC (MANIFOLD) | 16.00 | 3,200.00 |
| 180 | LF | 8 IN SCH 80 DOWN-FLOW PIPE | 6.00 | 1,080.00 |
| 2,065 | LF | 4 IN PVC SCH 80 | 1.40 | 2,891.00 |
| 4,455 | LF | 4 IN PVC SCH 80 (PERFORATED) | 1.70 | 7,573.50 |
| 5 | EACH | 6 IN ACID-RESIST. VALVE | 400.00 | 2,000.00 |
| 1.95 | ACRES | FERTILIZE, SEED, AND MULCH | 1,000.00 | 1,950.00 |
| 1.30 | ACRES | LIME APPLICATION - 25 T/AC | 1,200.00 | 1,560.00 |
| 1.95 | ACRES | SUMMER EROSION CONTROL | 600.00 | 1,170.00 |
| 1.49 | ACRES | PROVIDE CATTAILS | 10,000.00 | 14,900.00 |
| 615 | LF | UNLINED DRAINAGE DITCH | 2.50 | 1,537.50 |
| 375 | LF | LINED DRAINAGE DITCH | 4.50 | 1,687.50 |
| 320 | CY | RIP-RAP | 16.00 | 5,120.00 |
| 160 | LF | 18 IN CULVERT | 10.00 | 1,600.00 |
| 1,220 | LF | GRAVEL COURSE | 1.20 | 1,464.00 |
| 112 | KGAL | PROVIDE WATER | 14.00 | 1,568.00 |
| 590 | KGAL | FLOOD WETLAND | 8.00 | 4,720.00 |
| 680 | LF | REMOVE FENCE | 1.00 | 680.00 |
| 2,420 | LF | F-4 FARM FENCE | 0.85 | 2,057.00 |
| 9 | EACH | CORNER PANELS | 95.00 | 855.00 |
| 4 | EACH | SINGLE PANELS | 70.00 | 280.00 |
| 4 | EACH | F-4 GATES | 100.00 | 400.00 |
| 1 | LUMP SUM | BACKFILL AND COMPACT WELL | XXXXX | 500.00 |
| 1 | LUMP SUM | CLEAN OUT COLLECTION BOX/PIPE | XXXXX | 400.00 |
| 1 | LUMP SUM | INST. MANIFOLD IN COLLECT. BOX | XXXXX | 500.00 |
| 1 | LUMP SUM | REMOVE AND REPLACE STRUCTURE | XXXXX | 2,000.00 |
| | | | | ===== |
| | | | | 409,730.00 |

FRENCH COULEE
CASCADE COUNTY, MONTANA

DSL/AMRB 90-010
DATE JUNE 28, 1990

| BID TABULATIONS | | | | | | Ed Boland Construction Great Falls, MT | | Schumaker Contracting Great Falls, MT | | | | | |
|-----------------|-----------------------|------|-----------------------------------|---------------|----------------|---|------------|--|------------|--|--|------|------|
| Item Number | Estimated Quantity | Unit | Description | Unit Price | Total Price | | | | | | | | |
| 1. | 1 | LS | Mobilization | | | 30,000.00 | 30,000.00 | 30,500.00 | 30,500.00 | | | 0.00 | 0.00 |
| 2. | 1 | LS | Debris Removal | | | 1,250.00 | 1,250.00 | 500.00 | 500.00 | | | 0.00 | 0.00 |
| 3. | 1 | LS | Excavation and Embankment | | | 15,560.00 | 15,560.00 | 51,000.00 | 51,000.00 | | | 0.00 | 0.00 |
| 4. | 5,820 | CY | Provide Backfill | | | 4.30 | 25,026.00 | 6.00 | 34,920.00 | | | 0.00 | 0.00 |
| 5. | 2,840 | CY | Haul | | | 1.53 | 4,345.20 | 2.00 | 5,680.00 | | | 0.00 | 0.00 |
| 6. | 1,165 | CY | Provide Topsoil | | | 12.30 | 14,329.50 | 6.00 | 6,990.00 | | | 0.00 | 0.00 |
| 7. | 89,550 | SF | Soil/Clay Liner | | | 0.33 | 29,551.50 | 0.50 | 44,775.00 | | | 0.00 | 0.00 |
| 8. | 103,650 | SF | Geomembrane Liner | | | 0.73 | 75,664.50 | 0.45 | 46,642.50 | | | 0.00 | 0.00 |
| 9. | 103,650 | SF | Protective Geofabric | | | 0.23 | 23,839.50 | 0.20 | 20,730.00 | | | 0.00 | 0.00 |
| 10. | 86,900 | SF | Underlayment Fabric | | | 0.27 | 23,463.00 | 0.20 | 17,380.00 | | | 0.00 | 0.00 |
| 11. | 44,300 | SF | Soil Anchor Mat | | | 0.65 | 28,795.00 | 1.00 | 44,300.00 | | | 0.00 | 0.00 |
| 12. | 690 | CY | 1.5"/3.0" Gravel | | | 33.21 | 22,914.90 | 20.00 | 13,800.00 | | | 0.00 | 0.00 |
| 13. | 365 | CY | 0.5"/0.75" Gravel | | | 33.21 | 12,121.65 | 20.00 | 7,300.00 | | | 0.00 | 0.00 |
| 14. | 4,460 | CY | Organic Substrate | | | 25.21 | 112,436.60 | 25.00 | 111,500.00 | | | 0.00 | 0.00 |
| 15. | 740 | CY | Sand Substrate | | | 32.59 | 24,116.60 | 25.00 | 18,500.00 | | | 0.00 | 0.00 |
| 16. | 5 | EACH | Parshall Flume | | | 2,927.00 | 14,635.00 | 8,500.00 | 42,500.00 | | | 0.00 | 0.00 |
| 17. | 2,590 | LF | 8-inch PVC (Main/by-pass pipe) | | | 9.84 | 25,485.60 | 15.00 | 38,850.00 | | | 0.00 | 0.00 |

| BID TABULATIONS | | | | | | Ed Boland Construction Great Falls, MT | | Schumaker Contracting Great Falls, MT | | | | |
|-----------------|-----------------------|-------|----------------------------|---------------|----------------|---|-----------|--|-----------|--|------|------|
| Item Number | Estimated Quantity | Unit | Description | Unit Price | Total Price | | | | | | | |
| 18. | 105 | LF | 8-inch PVC Down Flow Pipe | | | 9.84 | 1,033.20 | 15.00 | 1,575.00 | | 0.00 | 0.00 |
| 19. | 200 | LF | 12-inch PVC manifold | | | 13.53 | 2,706.00 | 20.00 | 4,000.00 | | 0.00 | 0.00 |
| 20. | 200 | LF | 6-inch PVC Manifold | | | 7.38 | 1,476.00 | 20.00 | 4,000.00 | | 0.00 | 0.00 |
| 21. | 2,065 | LF | 4-inch PVC Sch. 80 | | | 3.80 | 7,847.00 | 7.00 | 14,455.00 | | 0.00 | 0.00 |
| 22. | 4,455 | LF | 4-inch PVC Sch. 80 Perf. | | | 4.70 | 20,938.50 | 7.00 | 31,185.00 | | 0.00 | 0.00 |
| 23. | 5 | EACH | Acid-resistant Valve | | | 1,110.00 | 5,550.00 | 2,000.00 | 10,000.00 | | 0.00 | 0.00 |
| 24. | 1.95 | ACRES | Fertilizer, Seed and Mulch | | | 500.00 | 975.00 | 2,000.00 | 3,900.00 | | 0.00 | 0.00 |
| 25. | 1.95 | ACRES | Lime Application (25 T/A) | | | 4,045.00 | 7,887.75 | 2,000.00 | 3,900.00 | | 0.00 | 0.00 |
| 26. | 1.3 | ACRES | Summer Erosion Control | | | 1,600.00 | 2,080.00 | 0.01 | 0.01 | | 0.00 | 0.00 |
| 27. | 1.49 | ACRES | Provide Cattails | | | 8,254.00 | 12,298.46 | 20,000.00 | 29,800.00 | | 0.00 | 0.00 |
| 28. | 615 | LF | Unlined Drainage Ditch | | | 5.55 | 3,413.25 | 1.00 | 615.00 | | 0.00 | 0.00 |
| 29. | 375 | LF | Lined Drainage Ditch | | | 6.55 | 2,456.25 | 20.00 | 7,500.00 | | 0.00 | 0.00 |
| 30. | 320 | CY | Rip-Rap | | | 22.15 | 7,088.00 | 30.00 | 9,600.00 | | 0.00 | 0.00 |
| 31. | 160 | LF | 18-inch Culvert | | | 22.75 | 3,640.00 | 30.00 | 4,800.00 | | 0.00 | 0.00 |
| 32. | 1,220 | LF | Gravel Course | | | 9.06 | 11,053.20 | 10.00 | 12,200.00 | | 0.00 | 0.00 |
| 33. | 112 | KGAL | Provide Water | | | 5.00 | 560.00 | 0.01 | 1.12 | | 0.00 | 0.00 |
| 34. | 590 | KGAL | Flood Wetland | | | 5.00 | 2,950.00 | 10.00 | 5,900.00 | | 0.00 | 0.00 |
| 35. | 680 | LF | Remove Fence | | | 0.65 | 442.00 | 1.00 | 680.00 | | 0.00 | 0.00 |
| 36. | 2,420 | LF | Farm Fence F-4M | | | 2.00 | 4,840.00 | 1.25 | 3,025.00 | | 0.00 | 0.00 |

| BID TABULATIONS | | | | | | Ed Boland Construction Great Falls, MT | | Schumaker Contracting Great Falls, MT | | | | |
|-----------------|-----------------------|------|---|---------------|----------------|---|------------|--|------------|--|------|------|
| Item Number | Estimated Quantity | Unit | Description | Unit Price | Total Price | | | | | | | |
| 37. | 9 | EACH | Corner Panels | | | 160.00 | 1,440.00 | 100.00 | 900.00 | | 0.00 | 0.00 |
| 38. | 4 | EACH | Single Panels | | | 100.00 | 400.00 | 80.00 | 320.00 | | 0.00 | 0.00 |
| 39. | 64 | LF | Farm Fence Gates Type F-4 (16 ft/gate) | | | 8.50 | 544.00 | 5.00 | 320.00 | | 0.00 | 0.00 |
| 40. | 1 | LS | Backfill and Compact Well | | | 400.00 | 400.00 | 100.00 | 100.00 | | 0.00 | 0.00 |
| 41. | 1 | LS | Clean Out Collection Box/ Pipe | | | 2,850.00 | 2,850.00 | 1,000.00 | 1,000.00 | | 0.00 | 0.00 |
| 42. | 1 | LS | Install Manifold in Collection Box | | | 2,350.00 | 2,350.00 | 1,500.00 | 1,500.00 | | 0.00 | 0.00 |
| 43. | 1 | LS | Remove and Replace Structure | | | 1,500.00 | 1,500.00 | 2,500.00 | 2,500.00 | | 0.00 | 0.00 |
| | | | | | | | 592,253.16 | | 689,643.63 | | 0.00 | 0.00 |

G:\RECLAM\AMRB\FRENCH.BID

ATTACHMENT 2
CHANGE ORDERS

CHANGE ORDER

ORDER NO: # 1

RECEIVED
 SEP 18 1990
 STATE LANDS

PROJECT TITLE: FRENCH COULEE WETLAND/ACID MINE DRAINAGE CONTROL

MONT A/E or DSL-AMRB: DSL/ANRB 90-010

CONTRACT DATE: JUNE 28, 1990

OWNER: MONTANA DEPT. OF STATE LANDS - AMR BUREAU

CONTRACTOR: ED BOLAND CONST. GT. FALLS, MT. 59401

Change Orders must be accompanied by an itemized cost breakdown. You are hereby requested to comply with the following changes from the Contract Documents. (Show separate costs for materials, labor, equipment, and miscellaneous. Show percent where applicable.)

| ITEM NO. | DESCRIPTION OF CHANGES - ESTIMATED QUANTITIES & UNITS | COST OF CHANGES | | | | TOTAL UNIT COST | TOTAL COST |
|--|---|-----------------|-------|--------|-------|-----------------|------------|
| | | MAT'LS. | LABOR | EQUIP. | MISC. | | |
| 35 | Remove additional fence 750 l.f. @ \$.65 per LF | | | | | | \$487.50 |
| TOTAL COST - MATERIALS, LABOR, EQUIPMENT & MISC. | | | | | | | |
| OVERHEAD & PROFIT @ _____% | | | | | | | |
| GRAND TOTAL - THIS CHANGE ORDER | | | | | | | \$487.50 |

| | |
|--|------------|
| Original Contract Price | \$442.00 |
| Current Contract Price Adjusted by Previous Change Order | |
| Cost this Change Order (+ or -) | + \$487.50 |
| New Contract Price including this Change Order | \$929.50 |

The completion date as set forth in the Contract Documents shall be (unchanged) increased, decreased) by calendar days.

The date for completion of all work will be same as initial

Description and Justification for Change:

1. Need for Access Development and location of Construction features (ditch, cells).

SURETY CONSENT

The Surety hereby consents to the aforementioned Contract Change Order and agrees that its bond or bonds shall apply and extend to the Contract as thereby modified or amended per this Change Order. The Principal and the Surety further agree that on or after execution of this consent, the penalty of the applicable Performance Bonds or Bonds is hereby increased by \$ 487.50 (100% of the Change Order amount) and the penalty of the applicable Labor and Material Bond or Bonds is hereby increased by \$ 487.50 (100% of the Change Order amount).

COUNTERSIGNED BY MONTANA
RESIDENT AGENT

SURETY

By: _____

Seal

Recommended by: *Richard Spotts*
Engineer

9/12/90
Date

Accepted by: *Raymond Adams*
Contractor

9/12/90
Date

Approved by: *Larry Marshall*
Owner

10/1/90
Date

CHANGE ORDER

ORDER NO: NO. 2

PROJECT TITLE: FRENCH COULEE WETLAND/ACID MINE DRAINAGE CONTROL

MONT A/E or DSL-AMRB: DSL-AMRB 90-010

CONTRACT DATE: JUNE 28, 1990

OWNER: MONTANA DEPARTMENT OF STATE LANDS - AMR BUREAU

CONTRACTOR: ED BOLAND CONSTRUCTION, GREAT FALLS, MT 59401

Change Orders must be accompanied by an itemized cost breakdown. You are hereby requested to comply with the following changes from the Contract Documents. (Show separate costs for materials, labor, equipment, and miscellaneous. Show percent where applicable.)

| ITEM NO. | DESCRIPTION OF CHANGES - ESTIMATED QUANTITIES & UNITS | COST OF CHANGES | | | | | TOTAL UNIT COST | TOTAL COST |
|--|---|-----------------|--------|--------|-------|--|-----------------|------------|
| | | MAT'LS | LABOR | EQUIP | MISC | | | |
| 44 (new) | Provide off-site soil materials suitable for construction of bentonite liners. Work item to include purchase, loading, hauling, stockpiling, and placement in wetland cells. Estimated quantity is 3,000 cu yds measured loose in trucks. | \$3.50 | \$1.50 | \$1.50 | \$.50 | | \$7.00 | +21,000 |
| 4 | Reduction in backfill locally provided. 2,000 compacted yards estimated. | | | | | | \$4.30 | - 8,600 |
| TOTAL COST - MATERIALS, LABOR, EQUIPMENT & MISC. | | | | | | | \$ 12,400.00 | |
| OVERHEAD & PROFIT \$ ____% | | | | | | | included | |
| GRAND TOTAL - THIS CHANGE ORDER | | | | | | | \$ 12,400.00 | |

| | |
|--|----------------------|
| Original Contract Price | <u>\$ 590,690.91</u> |
| Current Contract Price Adjusted by Previous Change Order | <u>\$ 591,178.41</u> |
| Cost this Change Order (+ or -) | <u>\$ +12,400.00</u> |
| New Contract Price including this Change Order | <u>\$ 603,578.41</u> |

The completion date as set forth in the Contract Documents shall be (unchanged, increased, decreased) by 10 calendar days.

The date for completion of all work will be November 5, 1990.

Description and Justification for Change:

1. **Materials suitable for bentonite liner construction were not available within the immediate area. Excavation materials had either too much rock, too much coal waste, or too much calcium. This necessitated a time consuming search for alternate materials off-site and testing of same. Purchase price of suitable material is substantially higher than on site material. Piping work was completed in Cell 1 on Saturday, September 22, 1990. Allowing another day (Monday, September 24, 1990) to trim Cell to final contours makes the first available date for lining September 25, 1990, a ten (10) calendar day delay based on the date of this Change Order.**

SURETY CONSENT

The Surety hereby consents to the aforementioned Contract Change Order and agrees that its bond or bonds shall apply and extend to the Contract as thereby modified or amended per this Change Order. The Principal and the Surety further agree that on or after execution of this consent, the penalty of the applicable Performance Bond or Bonds is hereby increased by \$ _____ (100% of the Change Order amount) and the penalty of the applicable Labor and Material Bond or Bonds is hereby increased by \$ _____ (100% of the Change Order amount).

COUNTERSIGNED BY MONTANA
RESIDENT AGENT

SURETY

FLYNN INSURANCE AGENCY

GREAT AMERICAN INSURANCE COMPANY

[Signature]

By: [Signature]

Recommended by: [Signature]
Engineer

LORI L. WALKER Seal ATTY-IN-FACT
10/4/90
Date

Accepted by: [Signature]
Contractor

10/4/90
Date

Approved by: sm [Signature]
Owner

10/12/90
Date

CHANGE ORDER

ORDER NO: NO. 3A

PROJECT TITLE: FRENCH COULEE WETLAND/ACID MINE DRAINAGE CONTROL

MONT A/E or DSL-AMRB: DSL-AMRB 90-010

CONTRACT DATE: JUNE 28, 1990

OWNER: MONTANA DEPARTMENT OF STATE LANDS - AMR BUREAU

CONTRACTOR: ED BOLAND CONSTRUCTION, GREAT FALLS, MT 59401

Change Orders must be accompanied by an itemized cost breakdown. You are hereby requested to comply with the following changes from the Contract Documents. (Show separate costs for materials, labor, equipment, and miscellaneous. Show percent where applicable.)

| ITEM NO. | DESCRIPTION OF CHANGES - ESTIMATED QUANTITIES & UNITS | COST OF CHANGES | | | | | TOTAL COST |
|--|--|-----------------|-------|-------|------|-----------------|------------|
| | | MAT'LS | LABOR | EQUIP | MISC | TOTAL UNIT COST | |
| 47 | Provide for Richard Chartier to remove and dispose of debris and provide weed control at DSL Chartier Mine Fire Project site. All (100%) labor and materials provide by R. Chartier under subcontract to Ed Boland Construction, Inc. of Great Falls, Montana. All work to be completed by January 31, 1991. . | | | | | | 500.00 |
| TOTAL COST - MATERIALS, LABOR, EQUIPMENT & MISC. | | | | | | \$ 500.00 | |
| OVERHEAD & PROFIT \$ ____% | | | | | | | |
| GRAND TOTAL - THIS CHANGE ORDER | | | | | | \$ 500.00 | |

| | |
|--|---------------|
| Original Contract Price | \$ 592,253.16 |
| Current Contract Price Adjusted by Previous Change Order | \$ 605,140.66 |
| Cost this Change Order (+ or -) | \$ + 500.00 |
| New Contract Price including this Change Order | \$ 605,640.66 |

The completion date as set forth in the Contract Documents shall be (unchanged, increased, decreased) by _____ calendar days.

The date for completion of all work will be January 31, 1991.

Description and Justification for Change:

1. **Owner directed change.**

SURETY CONSENT

The Surety hereby consents to the aforementioned Contract Change Order and agrees that its bond or bonds shall apply and extend to the Contract as thereby modified or amended per this Change Order. The Principal and the Surety further agree that on or after execution of this consent, the penalty of the applicable Performance Bond or Bonds is hereby increased by \$_____ (100% of the Change Order amount) and the penalty of the applicable Labor and Material Bond or Bonds is hereby increased by \$_____ (100% of the Change Order amount).

COUNTERSIGNED BY MONTANA
RESIDENT AGENT

SURETY

By: _____

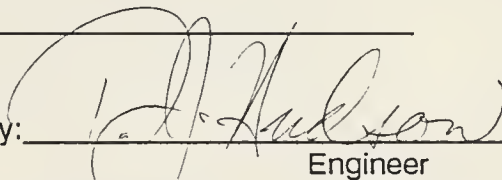
Recommended by: 
Engineer

Seal
12/12/90
Date

Accepted by: 
Contractor

12/12/90
Date

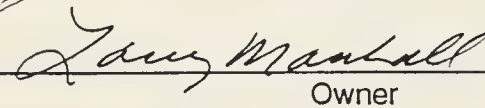
Approved by: ^{12/14/90} 
Owner

12/14/90
Date

CHANGE ORDER

ORDER NO: NO. 04

PROJECT TITLE: FRENCH COULEE WETLAND/ACID MINE DRAINAGE CONTROL

MONT A/E or DSL-AMRB: DSL-AMRB 90-010

CONTRACT DATE: JUNE 28, 1990

OWNER: MONTANA DEPARTMENT OF STATE LANDS - AMR BUREAU

CONTRACTOR: ED BOLAND CONSTRUCTION, GREAT FALLS, MT 59401

Change Orders must be accompanied by an itemized cost breakdown. You are hereby requested to comply with the following changes from the Contract Documents. (Show separate costs for materials, labor, equipment, and miscellaneous. Show percent where applicable.)

| ITEM NO. | DESCRIPTION OF CHANGES - ESTIMATED QUANTITIES & UNITS | COST OF CHANGES | | | | | TOTAL COST |
|--|---|-----------------|---------|-------|--------|----------------------------|-------------------|
| | | MAT'LS | LABOR | EQUIP | MISC | TOTAL UNIT COST | |
| 52 | Build and install locking caps on all PVC cleanouts | 485.69 | 585.00 | | | | 1070.69 |
| 53 | Install 1/2 inch stainless steel screens over all pipe openings in flumes. Replace all factory bolts for stop plates with stainless steel. Install steel chain and locks on all stop plates and all-thread hold down on redwood weir gates. | 1216.49 | 774.00 | | | | 1990.49 |
| 54 | Clean and manifold all existing in-flow pipes to south collection box. | 279.00 | 450.00 | | 138.00 | | 867.00 |
| 55 | Batten and seal HDPE liner to all concrete flumes. | | | | | | 3935.29 |
| 56 | Plant native shrubs on site. | 665.00 | 1075.00 | | | 1740.00 | 1740.00 |
| 57 | Install walk-through swing gates for school children access across site. | | | | | 350.00 | 350.00 |
| TOTAL COST - MATERIALS, LABOR, EQUIPMENT & MISC. | | | | | | \$ 9,953.47 | <u> </u> |
| *O/H and profit on items 52, 53, 54, 56 | | | | | | OVERHEAD & PROFIT \$ 15% % | \$ 850.23 |
| GRAND TOTAL - THIS CHANGE ORDER | | | | | | \$ 10,803.70 | <u> </u> |

| | |
|--|----------------------|
| Original Contract Price | <u>\$ 592,253.16</u> |
| Current Contract Price Adjusted by Previous Change Order | <u>\$ 605,640.66</u> |
| Cost this Change Order (+ or -) | <u>\$ 10,803.70</u> |
| New Contract Price including this Change Order | <u>\$ 616,444.36</u> |

The completion date as set forth in the Contract Documents shall be (~~unchanged~~, increased, decreased) by * calendar days. *see explanation below.

The date for completion of all work will be June 1, 1991 .

Description and Justification for Change:

1. All work was approximately 95% complete on December 18, 1990 and had been performed in a timely manner. On this date, a severe winter storm hit. Subsequent poor winter weather lead to the discontinuance of work. It had been decided that the planting of cattails, seeding/fertilizing/mulching, flooding of the wetland and completion of all remaining incidental tasks should commence at the earliest possible date in the Spring of 1991, and be completed in a timely manner. Work commenced again on 4/22/91. The date of completion for all work, with the exception of the planting of shrubs anticipated in Fall, 1991, shall be June 1, 1991.

SURETY CONSENT

The Surety hereby consents to the aforementioned Contract Change Order and agrees that its bond or bonds shall apply and extend to the Contract as thereby modified or amended per this Change Order. The Principal and the Surety further agree that on or after execution of this consent, the penalty of the applicable Performance Bond or Bonds is hereby increased by \$ 10,803.70 (100% of the Change Order amount) and the penalty of the applicable Labor and Material Bond or Bonds is hereby increased by \$ 10,803.70 (100% of the Change Order amount).

COUNTERSIGNED BY MONTANA
RESIDENT AGENT

SURETY

By: _____

Recommended by: _____

Edward J. Smith
Engineer

Seal

5/22/91
Date

Accepted by: _____

Contractor

_____ Date

Approved by: _____

Owner

_____ Date

ATTACHMENT 3
PAYMENT REQUESTS

PAYMENT REQUEST NO. -1-

FROM 28 AUG 90 TO 28 SEPT 90

PROJECT TITLE: FRENCH COULEE WETLAND/ACID MINE DRAINAGE CONTROL

LOCATION: BELT, MONTANA MONT A/E or DSL-AMRB: 90-010

NAME OF CONTRACTOR: ED BOLAND CONSTRUCTION, INC.

ADDRESS: 2608 NINTH AVENUE NORTH, GREAT FALLS, MT 59405

| CHANGE ORDERS | | | CONTRACT STATUS | | | | |
|---|--------------------------|----------|-----------------|-----------------------------|--------------------|------------------|---------------|
| No. | Description | Amount | Total Amount | Completed Amount | Uncompleted Amount | Percent Complete | |
| 1 | Additional Fence Removal | 487.50 | 590,691.00 | 161,737.00 | 428,954.00 | 27.4 | |
| 2 | Off-Site Soils | 5,250.00 | | | | | |
| Total Change Orders | | | 5,737.50 | | | | |
| CONTRACT TO DATE INCLUDING CHANGE ORDERS | | | \$ 161,736.58 | COMPLETED TO DATE | | | \$ 75,783.23 |
| | | | | PLUS MATERIALS ON SITE | | | \$ 85,953.35 |
| *for use only when securities are on deposit in lieu of retainage | | | | TOTAL COMPLETED TO DATE | | | \$ 161,736.58 |
| TOTAL RETAINAGE | | | \$ _____ | CHANGE ORDERS TO DATE | | | \$ 16,173.66 |
| SECURITIES ON DEPOSIT | | | \$ _____ | TOTAL AMOUNT EARNED TO DATE | | | \$ 145,562.92 |
| ADJUSTED RETAINAGE | | | \$ _____ | LESS PREVIOUS PAYMENTS | | | \$ 0.00 |
| | | | | AMOUNT DUE THIS PAYMENT | | | \$ 145,562.92 |
| | | | | LESS 1% TAX | | | \$ 1,455.63 |
| | | | | TOTAL DUE CONTRACT | | | \$ 144,107.29 |

I certify that this claim is correct and just in all respects and that payment or credit has not been received.

APPROVED BY:

BOLAND CONSTRUCTION, INC.

DEPARTMENT OF STATE LANDS - AMR BUREAU

Contractor

Owner

By Ed Boland

By Jerry Marshall

Date 10/5/90

Date 10/12/90

RECOMMENDED BY:

SCHAFFER AND ASSOCIATES

Engineer

By [Signature]

Date 10/4/90

ITEMIZATION OF QUANTITIES AND COSTS

| Item | Description | Estimated Plan Quantity | Unit Price Bid | Units of Work Completed To Date | Total Cost of Completed Work | Percent Complete |
|--------------|---|-------------------------|----------------|---------------------------------|------------------------------|------------------|
| 1 | Mobilization | L.S. | 30,000.00 | L.S. | 30,000.00 | 100 |
| 2 | Debris Removal | L.S. | 1,250.00 | L.S. | 1,250.00 | 100 |
| 3 | Excavation and Embankment | L.S. | 15,560.00 | 90% | 14,364.00 | 90 |
| 4 | Provide Backfill | 5,820 CY | 4.30 | 4,300 CY | 18,490.00 | 74 |
| 5 | Haul (revised as of today, 9/27/90) | 2,840 CY | 1.53 | 741 CY | 1,133.73 | 75 |
| 31 | 18" culvert | 160 LF | 22.75 | 104 LF | 2,366.00 | 65 |
| 33 | Provide Water | K-GAL | 5.00 | 20,000 G | 100.00 | 17 |
| 35 | Remove Fence (see CO#1) | 680 LF | 0.65 | 680 LF | 442.00 | 100 |
| 40 | Backfill and Compact Well | L.S. | 400.00 | L.S. | 400.00 | 100 |
| 43 | Remove and Replace Structure | L.S. | 1,500.00 | L.S. | 1,500.00 | 100 |
| CO#1 | Remove Additional Fence | 750 LF | 0.65 | 750 LF | 487.50 | 100 |
| CO#2 | Provide off-site soil materials for bentonite liner (50% prepayment to Landowner) | 3,000 YD (loose) | 7.00 | -0- | 5,250.00 | 0 |
| TOTAL | | | | | \$ 75,783.23 | |

SCHEDULE OF MATERIAL ON SITE

PROJECT TITLE: FRENCH COULEE/WETLANDS ACID MINE DRAINAGE CONTROL

DSL-AMRB: 90-010

CONTRACTOR: ED BOLAND CONST. GREAT FALLS, MONTANA 59401

| | | |
|-------------------|---|-----------------------------|
| Item <u>8</u> | Material Delivered <u>GEOMEMBRANE LINER</u> | |
| | Material in Place <u>WESTERN INDUSTRIES INC.</u> | |
| | Material on Site 103,650 sq.ft. | <u>\$30,071.25</u> |
| Item <u>11</u> | Material Delivered <u>SOIL ANCHOR MAT.</u> | |
| | Material in Place <u>AMERICAN EXCELSIOR</u> | |
| | Material on Site 44,300 sq.ft. | <u>\$19,009.36</u> |
| Item <u>10</u> | Material Delivered <u>UNDERLAYMENT FABRIC</u> | |
| | Material in Place <u>MACON SUPPLY</u> | |
| | Material on Site 86,900 sq.ft. | <u>\$12,960.00</u> |
| Item <u>9</u> | Material Delivered <u>PROTECTIVE GEOFABRIC</u> | |
| | Material in Place <u>ROSCOE STEEL</u> | |
| | Material on Site 103,650 sq.ft. | <u>\$14,054.94</u> |
| Item <u>17-18</u> | Material Delivered <u>8in. P.V.C. PIPE</u> | |
| | Material in Place <u>DANA KEPNER</u> | |
| | Material on Site 2740 LF | <u>\$7,946.00</u> |
| Item <u>19</u> | Material Delivered <u>12 in. P.V.C. PIPE</u> | |
| | Material in Place <u>DANA KEPNER</u> | <u>\$1,537.80</u> |
| | Material on Site 200 LF | <u> </u> |
| Item <u>20</u> | Material Delivered <u>6 in. P.V.C. PIPE</u> | |
| | Material in Place <u>DANA KEPNER</u> | |
| | Material on Site 200 LF | <u>\$374.00</u> |
| | TOTAL MATERIAL ON SITE | <u>\$85,953.35</u> |
| | (Attach applicable invoices or bills of lading) | |

Requested by: ED BOLAND CONST. 2608 9TH AVE. NO. Gt.Falls, MT. 59401
(Contractor)

To be included in Payment Request No. -1-

PAYMENT REQUEST NO. -2-

FROM 29 SEPT 90 TO 31 OCT 90

PROJECT TITLE: FRENCH COULEE WETLAND/ACID MINE DRAINAGE CONTROL

LOCATION: BELT, MONTANA MONT A/E or DSL-AMRB: 90-010

NAME OF CONTRACTOR: ED BOLAND CONSTRUCTION, INC.

ADDRESS: 2508 NINTH AVENUE NORTH, GREAT FALLS, MT 59405

| CHANGE ORDERS | | | CONTRACT STATUS | | | |
|---|-------------|-----------|-----------------------------|------------------|--------------------|------------------|
| No. | Description | Amount | Total Amount | Completed Amount | Uncompleted Amount | Percent Complete |
| 1 | | 487.50 | 605,140.66 | 302,549.12 | 302,591.54 | 50.0 |
| 2 | | 12,400.00 | | | | |
| | | | | | | |
| Total Change Orders | | 12,887.50 | | | | |
| CONTRACT TO DATE INCLUDING CHANGE ORDERS \$ 605,140.66 | | | COMPLETED TO DATE | | \$ 302,549.12 | |
| | | | PLUS MATERIALS ON SITE | | \$ 43,357.85 | |
| *for use only when securities are on deposit in lieu of retainage | | | TOTAL COMPLETED TO DATE | | \$ 345,906.97 | |
| TOTAL RETAINAGE \$ _____ | | | RETAINAGE (10%) | | \$ 34,590.70 | |
| SECURITIES ON DEPOSIT \$ _____ | | | TOTAL AMOUNT EARNED TO DATE | | \$ 311,316.27 | |
| ADJUSTED RETAINAGE \$ _____ | | | LESS PREVIOUS PAYMENTS | | \$ 144,107.29 | |
| | | | AMOUNT DUE THIS PAYMENT | | \$ 167,208.33 | |
| | | | LESS 1% TAX | | \$ 1,672.08 | |
| | | | TOTAL DUE CONTRACT | | \$ 165,536.30 | |

I certify that this claim is correct and just in all respects and that payment or credit has not been received.

APPROVED BY:

BOLAND CONSTRUCTION, INC.
Contractor

DEPARTMENT OF STATE LANDS - AMR BUREAU
Owner

By [Signature]

By [Signature]

Date 11/17/90

Date 11/4/90

RECOMMENDED BY:

SCHAFER AND ASSOCIATES
Engineer

By [Signature]

Date 11/7/90

ITEMIZATION OF QUANTITIES AND COSTS

| Item | Description | Estimated Plan Quantity | Unit Price Bid | Units of Work Completed to Date | Total Cost of Complete Work | Percent Complete |
|----------|---------------------------|-------------------------|----------------|---------------------------------|-----------------------------|------------------|
| 1 | Mobilization | L.S. | 30,000.00 | 100% | 30,000.00 | 100 |
| 2 | Debris Removal | L.S. | 1,250.00 | 100% | 1,250.00 | 100 |
| 3 | Excavation and Embankment | L.S. | 15,560.00 | 90% | 14,364.00 | 90 |
| 4 | Provide Backfill | 5,820 CY | 4.30 | 5,340 CY | 22,962.00 | 100 |
| 5 | Haul | 2,840 CY | 1.53 | 988 CY | 1,511.64 | 100 |
| 6 | Provide Topsoil | 1,165 CY | 12.30 | 111 CY | 1,365.30 | 10 |
| 7 | Soil-Clay Liner | 89,550 SF | .33 | 79,621 SF | 26,274.93 | 95 |
| 8 | Geomembrane | 103,650 SF | .73 | 90,327 SF | 65,938.71 | 95 |
| 9 | Geofabric | 103,650 SF | .23 | 90,327 SF | 20,775.21 | 95 |
| 10 | Underlayment | 86,900 SF | .27 | 0 | 0.00 | 0 |
| 11 | Anchormat | 44,300 SF | .65 | 42,000 SF | 27,300 | 100 |
| 12 | 3 x 1-1/2 Gravel | 690 CY | 33.21 | 0 | 0.00 | 0 |
| 13 | 1-3/4 x 1/2 Gravel | 365 CY | 33.21 | 0 | 0.00 | 0 |
| 14 | Organic Substrate | 4,460 CY | 25.21 | 0 | 0.00 | 0 |
| 15 | Sand Substrate | 740 CY | 32.59 | 0 | 0.00 | 0 |
| 16 | Parshall Flume | each | 2,927.00 | 0 | 0.00 | 0 |
| 17 | 8" PVC Main/Bypass | 2,590 LF | 9.84 | 1,990 LF | 19,581.60 | 80 |
| 18 | 8" Downflow (Sch 80) | 105 LF | 9.84 | 0 | 0.00 | 0 |
| 19 | 12" PVC Manifold | 200 LF | 13.53 | 211 LF | 2,854.83 | 100 |
| 20 | 6" PVC Manifold | 200 LF | 7.38 | 120 LF | 885.60 | 100 |
| 21 | 4" Sch 80 PVC | 2,065 LF | 3.80 | 1,361 LF | 5,171.80 | 65 |
| 22 | 4" Sch 80 Perf PVC | 4,455 LF | 4.70 | 2,806 LF | 13,188.20 | 65 |
| 23 | Acid Resist Valves | 5 each | 1,110.00 | 2 each | 2,220.00 | 40 |
| 24 | Fertilize, Seed, Mulch | 1.95 acre | 500.00 | 0 | 0.00 | 0 |
| 25 | Lime Application | 1.95 acre | 4,045.00 | .24 acre | 970.80 | 15 |
| 26 | Summer Erosion Control | 1.3 acre | 1,600.00 | 0 | 0.00 | 0 |
| 27 | Cattails | 1.49 acre | 8,254.00 | 0 | 0.00 | 0 |
| 28 | Unlined Ditch | 615 LF | 5.55 | 0 | 0.00 | 0 |
| 29 | Lined Ditch | 375 LF | 6.55 | 0 | 0.00 | 0 |
| 30 | Rip-Rap | 320 CY | 22.15 | 220 CY | 4,873.00 | 100 |
| 31 | 18" Culvert | 160 LF | 22.75 | 104 LF | 2,366.00 | 65 |
| 32 | Gravel Course | 1,220 LF | 9.06 | 1,100 LF | 9,966.00 | 80 |
| SUBTOTAL | | | | | 273,819.62 | |

SCHEDULE OF MATERIAL ON SITE

PROJECT TITLE: FRENCH COULEE WETLAND/ACID MINE DRAINAGE CONTROL

DSL-AMRB: 90-010

CONTRACTOR: ED BOLAND CONSTRUCTION

| | | |
|----------------|--|---------------------------|
| Item <u>8</u> | Material Delivered <u>Geomembrane Liner</u> Material in Place <u>90,327 sq. ft.</u> Material on Site <u>23,000 sq. ft.</u> | \$ <u>5,692.50</u> |
| Item <u>9</u> | Material Delivered <u>Protective Geofabric</u> Material in Place <u>90,327 sq. ft.</u> Material on Site <u>13,323 sq. ft.</u> | \$ <u>1,806.60</u> |
| Item <u>10</u> | Material Delivered <u>Underlayment Fabric</u> Material in Place <u>0</u> Material on Site <u>86,900 sq. ft.</u> | \$ <u>12,960.00</u> |
| Item <u>12</u> | Material Delivered <u>3" Gravel</u> Material in Place <u>0</u> Material on Site <u>approx. 670 CY</u> | \$ <u>8,612.33</u> |
| Item <u>14</u> | Material Delivered <u>Organic Substrate</u> Material in Place <u>0</u> Material on Site <u>410 CY</u> | \$ <u>6,970.00</u> |
| Item <u>16</u> | Material Delivered <u>Parshall Flume</u> Material in Place <u>5 each</u> Material on Site <u>5 each</u> | \$ <u>3,625.00</u> |
| Item <u>17</u> | Material Delivered <u>8" PVC</u> Material in Place <u>1990 ft.</u> Material on Site <u>742 ft.</u> | \$ <u>2,151.80</u> |
| Item <u>19</u> | Material Delivered <u>12" PVC Pipe</u> Material in Place <u>211 ft.</u> Material on Site <u>8 ft.</u> | \$ <u>55.92</u> |
| Item <u>20</u> | Material Delivered <u>6" PVC Pipe</u> Material in Place <u>120 ft. installed</u> Material on Site <u>100 ft.</u> | \$ <u>170.00</u> |
| Item <u>23</u> | Material Delivered <u>Acid Resistive Valve, Valve Box, Riser and Stem Extension</u> Material in Place <u>2 each</u> Material on Site <u>1 each</u> | \$ <u>732.00</u> |
| Item <u>31</u> | Material Delivered <u>18" Culvert</u> Material in Place <u>104 ft. installed</u> Material on Site <u>56 ft.</u> | \$ <u>581.70</u> |
| | TOTAL MATERIAL ON SITE (Attach applicable Invoices or bills of lading) | \$<u>43,357.85</u> |

Requested by: Ed Boland Construction
(Contractor)

To be included in Payment Request No. 2.

PAYMENT REQUEST NO. -3-

FROM 01 NOV 90 TO 07 DEC 90

PROJECT TITLE: FRENCH COULEE WETLAND/ACID MINE DRAINAGE CONTROL

LOCATION: BELT, MONTANA MONT A/E or DSL-AMRB: 90-010

NAME OF CONTRACTOR: ED BOLAND CONSTRUCTION, INC.

ADDRESS: 2608 NINTH AVENUE NORTH, GREAT FALLS, MT 59405

| CHANGE ORDERS | | | CONTRACT STATUS | | | |
|---|------------------------|---------------|--|------------------|--------------------|------------------|
| No. | Description | Amount | Total Amount | Completed Amount | Uncompleted Amount | Percent Complete |
| 1 | Additional Fence Reimb | 487.50 | 605,640.66 | 595,215.63 | 52,458.38* | 91.9 |
| 2 | Offsite Soils | 12,400.00 | | | | |
| 3A | Chartier Mine Fire | 500.00 | | | | |
| Total Change Orders | | 13,387.50 | *INCLUDES OUTSTANDING WORK DIRECTIVE CHANGES | | | |
| CONTRACT TO DATE INCLUDING CHANGE ORDERS | | \$ 605,640.66 | COMPLETED TO DATE | | \$ 595,215.63 | |
| | | | PLUS MATERIALS ON SITE | | \$ 16,541.92 | |
| | | | TOTAL COMPLETED TO DATE | | \$ 611,757.55 | |
| *for use only when securities are on deposit in lieu of retainage | | | RETAINAGE (10%) | | \$ 61,175.75 | |
| TOTAL RETAINAGE | \$ _____ | | TOTAL AMOUNT EARNED TO DATE | | \$ 550,581.80 | |
| SECURITIES ON DEPOSIT | \$ _____ | | LESS PREVIOUS PAYMENTS | | \$ 312,771.30 | |
| ADJUSTED RETAINAGE | \$ _____ | | AMOUNT DUE THIS PAYMENT | | \$ 237,810.50 ✓ | |
| | | | LESS 1% TAX | | \$ 2,378.10 | |
| | | | TOTAL DUE CONTRACT | | \$ 235,432.40 | |

I certify that this claim is correct and just in all respects and that payment or credit has not been received.

APPROVED BY:

BOLAND CONSTRUCTION, INC.
Contractor

DEPARTMENT OF STATE LANDS - AMR BUREAU
Owner

By [Signature]

By [Signature]

Date 12/12/90

Date 12/14/90

RECOMMENDED BY:

SCHAFFER AND ASSOCIATES
Engineer

By [Signature]

Date 12/12/90

RECEIVED

DEC 12 1990

STATE LANDS

ITEMIZATION OF QUANTITIES AND COSTS

| Item | Description | Estimated Plan Quantity | Unit Price Bid | Units of Work Completed to Date | Total Cost of Complete Work | Percent Complete |
|----------|---------------------------|-------------------------|----------------|---------------------------------|-----------------------------|------------------|
| 1 | Mobilization | L.S. | 30,000.00 | 100% | 30,000.00 | 100 |
| 2 | Debris Removal | L.S. | 1,250.00 | 100% | 1,250.00 | 100 |
| 3 | Excavation and Embankment | L.S. | 15,560.00 | 100% | 15,560.00 | 100 |
| 4 | Provide Backfill | 5,820 CY | 4.30 | 5,340 CY | 22,962.00 | 100 |
| 5 | Haul | 2,840 CY | 1.53 | 988 CY | 1,511.64 | 100 |
| 6 | Provide Topsoil | 1,165 CY | 12.30 | 1366 CY | 16,801.80 | 95 |
| 7 | Soil-Clay Liner | 89,550 SF | .33 | 79,621 SF | 26,274.93 | 100 |
| 8 | Geomembrane | 103,650 SF | .73 | 90,327 SF | 65,938.71 | 95 |
| 9 | Geofabric | 103,650 SF | .23 | 90,327 SF | 20,775.21 | 100 |
| 10 | Underlayment | 86,900 SF | .27 | 76,788 SF | 20,732.76 | 100 |
| 11 | Anchormat | 44,300 SF | .65 | 42,000 SF | 27,300.00 | 100 |
| 12 | 3 x 1-1/2 Gravel | 690 CY | 33.21 | 861 CY | 28,593.81 | 100 |
| 13 | 1-3/4 x 1/2 Gravel | 365 CY | 33.21 | 596 CY | 19,793.16 | 100 |
| 14 | Organic Substrate | 4,460 CY | 25.21 | 5392 CY | 135,932.32 | 100 |
| 15 | Sand Substrate | 740 CY | 32.59 | 1,454 CY | 47,385.86 | 100 |
| 16 | Parshall Flume | 5 each | 2,927.00 | 2 @ 75% | 4,390.50 | 30 |
| 17 | 8" PVC Main/Bypass | 2,590 LF | 9.84 | 2,350 LF | 23,124.00 | 80 |
| 18 | 8" Downflow (Sch 80) | 105 LF | 9.84 | 140 LF | 1,377.60 | 100 |
| 19 | 12" PVC Manifold | 200 LF | 13.53 | 211 LF | 2,854.83 | 100 |
| 20 | 6" PVC Manifold | 200 LF | 7.38 | 120 LF | 885.60 | 100 |
| 21 | 4" Sch 80 PVC (solid) | 2,065 LF | 3.80 | 1,721 LF | 6,539.80 | 100 |
| 22 | 4" Sch 80 Perf PVC | 4,455 LF | 4.70 | 4,456 LF | 20,943.20 | 100 |
| 23 | Acid Resist Valves | 5 each | 1,110.00 | 2 each | 2,220.00 | 40 |
| 24 | Fertilize, Seed, Mulch | 1.95 acre | 500.00 | 0 | 0.00 | 0 |
| 25 | Lime Application | 1.95 acre | 4,045.00 | .24 acre | 970.80 | 15 |
| 26 | Summer Erosion Control | 1.3 acre | 1,600.00 | 0 | 0.00 | 0 |
| 27 | Cattails | 1.49 acre | 8,254.00 | 0 | 0.00 | 0 |
| 28 | Unlined Ditch | 615 LF | 5.55 | 0 | 0.00 | 0 |
| 29 | Lined Ditch | 375 LF | 6.55 | 0 | 0.00 | 0 |
| 30 | Rip-Rap | 320 CY | 22.15 | 220 CY | 4,873.00 | 100 |
| 31 | 18" Culvert | 160 LF | 22.75 | 104 LF | 2,366.00 | 100 |
| 32 | Gravel Course | 1,220 LF | 9.06 | 1,430 LF | 12,955.80 | 100 |
| SUBTOTAL | | | | | 564,313.33 | |

PAYMENT REQUEST NO. -4-

FROM 08 DEC 90 TO 31 DEC 90

PROJECT TITLE: FRENCH COULEE WETLAND/ACID MINE DRAINAGE CONTROL

LOCATION: BELT, MONTANA MONT A/E or DSL-AMRB: 90-010

NAME OF CONTRACTOR: ED BOLAND CONSTRUCTION, INC.

ADDRESS: 2608 NINTH AVENUE NORTH, GREAT FALLS, MT 59405

| CHANGE ORDERS | | | CONTRACT STATUS | | | |
|---|------------------------|-----------|--|------------------|-------------------------------|------------------|
| No. | Description | Amount | Total Amount | Completed Amount | Uncompleted Amount | Percent Complete |
| 1 | Additional Fence Reimb | 487.50 | 605,640.66 | 639,965.50 | 24,763.46* | 96.4 |
| 2 | Offsite Soils | 12,400.00 | | | | |
| 3A | Chartier Mine Fire | 500.00 | | | | |
| Total Change Orders | | 13,387.50 | *INCLUDES OUTSTANDING WORK DIRECTIVE CHANGES | | | |
| CONTRACT TO DATE INCLUDING CHANGE ORDERS | | | \$ 605,640.66 | | COMPLETED TO DATE | |
| | | | | | \$ 635,902.57 | |
| *for use only when securities are on deposit in lieu of retainage | | | | | PLUS MATERIALS ON SITE | |
| | | | | | \$ 4,063.69 | |
| TOTAL RETAINAGE | | | | | TOTAL COMPLETED TO DATE | |
| \$ _____ | | | | | \$ 639,966.26 | |
| SECURITIES ON DEPOSIT | | | | | RETAINAGE (released for 1990) | |
| \$ _____ | | | | | \$ 0.00 | |
| ADJUSTED RETAINAGE | | | | | TOTAL AMOUNT EARNED TO DATE | |
| \$ _____ | | | | | \$ 639,966.26 | |
| | | | | | LESS PREVIOUS PAYMENTS | |
| | | | | | \$ 550,581.80 | |
| | | | | | AMOUNT DUE THIS PAYMENT | |
| | | | | | \$ 89,384.46 | |
| | | | | | LESS 1% TAX | |
| | | | | | \$ 893.84 | |
| | | | | | TOTAL DUE CONTRACT | |
| | | | | | \$ 88,490.62 | |

I certify that this claim is correct and just in all respects and that payment or credit has not been received.

APPROVED BY:

BOLAND CONSTRUCTION, INC.
Contractor

DEPARTMENT OF STATE LANDS - AMR BUREAU
Owner

By [Signature]

By SJM [Signature]

Date 1-24-91

Date 2/4/91

RECOMMENDED BY:

SCHAFFER AND ASSOCIATES
Engineer

By [Signature]

Date 1/22/91

ITEMIZATION OF QUANTITIES AND COSTS

| Item | Description | Estimated Plan Quantity | Unit Price Bid | Units of Work Completed to Date | Total Cost of Complete Work | Percent Complete |
|----------|---------------------------|-------------------------|----------------|---------------------------------|-----------------------------|------------------|
| 1 | Mobilization | L.S. | 30,000.00 | 100% | 30,000.00 | 100 |
| 2 | Debris Removal | L.S. | 1,250.00 | 100% | 1,250.00 | 100 |
| 3 | Excavation and Embankment | L.S. | 15,560.00 | 100% | 15,560.00 | 100 |
| 4 | Provide Backfill | 5,820 CY | 4.30 | 5,340 CY | 22,962.00 | 100 |
| 5 | Haul | 2,840 CY | 1.53 | 988 CY | 1,511.64 | 100 |
| 6 | Provide Topsoil | 1,165 CY | 12.30 | 1642 CY | 20,196.60 | 100 |
| 7 | Soil-Clay Liner | 89,550 SF | .33 | 79,621 SF | 26,274.93 | 100 |
| 8 | Geomembrane | 103,650 SF | .73 | 90,327 SF | 65,938.71 | 100 |
| 9 | Geofabric | 103,650 SF | .23 | 90,327 SF | 20,775.21 | 100 |
| 10 | Underlayment | 86,900 SF | .27 | 76,788 SF | 20,732.76 | 100 |
| 11 | Anchormat | 44,300 SF | .65 | 42,000 SF | 27,300.00 | 100 |
| 12 | 3 x 1-1/2 Gravel | 690 CY | 33.21 | 861 CY | 28,593.81 | 100 |
| 13 | 1-3/4 x 1/2 Gravel | 365 CY | 33.21 | 596 CY | 19,793.16 | 100 |
| 14 | Organic Substrate | 4,460 CY | 25.21 | 5392 CY | 135,932.32 | 100 |
| 15 | Sand Substrate | 740 CY | 32.59 | 1,454 CY | 47,385.86 | 100 |
| 16 | Parshall Flume | 5 each | 2,927.00 | 5 @ 90% | 13,171.50 | 90 |
| 17 | 8" PVC Main/Bypass | 2,590 LF | 9.84 | 2,864 LF | 28,181.76 | 100 |
| 18 | 8" Downflow (Sch 80) | 105 LF | 9.84 | 140 LF | 1,377.60 | 100 |
| 19 | 12" PVC Manifold | 200 LF | 13.53 | 211 LF | 2,854.83 | 100 |
| 20 | 6" PVC Manifold | 200 LF | 7.38 | 120 LF | 885.60 | 100 |
| 21 | 4" Sch 80 PVC (solid) | 2,065 LF | 3.80 | 1,721 LF | 6,539.80 | 100 |
| 22 | 4" Sch 80 Perf PVC | 4,455 LF | 4.70 | 4,456 LF | 20,943.20 | 100 |
| 23 | Acid Resist Valves | 5 each | 1,110.00 | 11 each | 12,210.00 | 100 |
| 24 | Fertilize, Seed, Mulch | 1.95 acre | 500.00 | 0 | 0.00 | 0 |
| 25 | Lime Application | 1.95 acre | 4,045.00 | .52 acre | 2,103.40 | 100 |
| 26 | Summer Erosion Control | 1.3 acre | 1,600.00 | 0 | 0.00 | 0 |
| 27 | Cattails | 1.49 acre | 8,254.00 | 0 | 0.00 | 0 |
| 28 | Unlined Ditch | 615 LF | 5.55 | 105 LF | 582.75 | 100 |
| 29 | Lined Ditch (Deleted) | | | | | |
| 30 | Rip-Rap | 320 CY | 22.15 | 255 CY | 5,648.75 | 95 |
| 31 | 18" Culvert | 160 LF | 22.75 | 104 LF | 2,366.00 | 100 |
| 32 | Gravel Course | 1,220 LF | 9.06 | 1,430 LF | 12,955.80 | 100 |
| SUBTOTAL | | | | | 594,027.99 | |

SCHEDULE OF MATERIAL ON SITE

PROJECT TITLE: FRENCH COULEE WETLAND/ACID MINE DRAINAGE CONTROL

DSL-AMRB: 90-010

CONTRACTOR: ED BOLAND CONSTRUCTION

| | | |
|----------------|---|--------------------|
| Item <u>7</u> | Material Delivered <u>Bentonite</u> Material in Place <u>79,621 sq. ft.</u> Material on Site <u>6.5 tons w/bags</u> | \$ <u>593.00</u> |
| Item <u>8</u> | Material Delivered <u>Geomembrane Liner</u> Material in Place <u>90,327 sq. ft.</u> Material on Site <u>9,000 sq. ft.</u> | \$ <u>2,226.60</u> |
| Item <u>9</u> | Material Delivered <u>Geofabric</u> Material in Place <u>90,327 sq. ft.</u> Material on Site <u>1,215 sq. ft.</u> | \$ <u>139.72</u> |
| Item <u>10</u> | Material Delivered <u>Underlayment Fabric</u> Material in Place <u>85,320 sq. ft.</u> Material on Site <u>1,080 sq. ft.</u> | \$ <u>146.45</u> |
| Item <u>19</u> | Material Delivered <u>12" PVC Pipe</u> Material in Place <u>211 ft.</u> Material on Site <u>8 ft.</u> | \$ <u>55.92</u> |
| Item <u>20</u> | Material Delivered <u>6" PVC Pipe</u> Material in Place <u>120 ft. installed</u> Material on Site <u>100 ft.</u> | \$ <u>170.00</u> |
| Item <u>23</u> | Material Delivered <u>Acid Resistive Valve, Valve Box, Riser and Stem Extension</u> Material in Place <u>11 each</u> Material on Site <u>1 each</u> | \$ <u>732.00</u> |

TOTAL MATERIAL ON SITE \$ 4,063.69
(Attach applicable invoices or bills of lading)

Requested by: Ed Boland Construction
(Contractor)

To be included in Payment Request No. 4.

Ed Spotts

PAYMENT REQUEST NO. -5-

FROM 01 JAN 91 TO 01 JUNE 91

PROJECT TITLE: FRENCH COULEE WETLAND/ACID MINE DRAINAGE CONTROL

LOCATION: BELT, MONTANA MONT A/E or DSL-AMRB: 90-010

NAME OF CONTRACTOR: ED BOLAND CONSTRUCTION, INC.

ADDRESS: 2608 NINTH AVENUE NORTH, GREAT FALLS, MT 59405

| CHANGE ORDERS | | | CONTRACT STATUS | | | |
|---|-------------------|--------|--|------------------|--------------------|------------------|
| No. | Description | Amount | Total Amount | Completed Amount | Uncompleted Amount | Percent Complete |
| ** | See attached list | | 616,444.36 | 676,955.48 | 0.00* | 100 |
| Total Change Orders 24,191.20 | | | *INCLUDES OUTSTANDING WORK DIRECTIVE CHANGES | | | |
| CONTRACT TO DATE INCLUDING CHANGE ORDERS \$ 616,444.36 | | | COMPLETED TO DATE \$ 676,955.48 | | | |
| *for use only when securities are on deposit in lieu of retainage | | | PLUS MATERIALS ON SITE \$ 732.00 | | | |
| TOTAL RETAINAGE \$ _____ | | | TOTAL COMPLETED TO DATE \$ 677,687.48 | | | |
| SECURITIES ON DEPOSIT \$ _____ | | | RETAINAGE (for 1991) \$ 3,772.20 0 | | | |
| ADJUSTED RETAINAGE \$ _____ | | | TOTAL AMOUNT EARNED TO DATE \$ 673,913.28 677,687.48 | | | |
| | | | LESS PREVIOUS PAYMENTS \$ 639,965.50 | | | |
| | | | AMOUNT DUE THIS PAYMENT \$ 33,949.78 37,721.98 | | | |
| | | | LESS 1% TAX \$ 339.50 377.22 | | | |
| | | | TOTAL DUE CONTRACT \$ 33,610.28 } 35,344.76 } 2 } checked | | | |
| | | | E | | | |

Ym mb

we'll be the \$200 til comp

I certify that this claim is correct and just in all respects and that payment or credit has not been received.

APPROVED BY:

BOLAND CONSTRUCTION, INC.
Contractor

DEPARTMENT OF STATE LANDS - AMR BUREAU
Owner

By [Signature]

By [Signature]

Date 5-28-91

Date 5/31/91

RECOMMENDED BY:

SCHAFFER AND ASSOCIATES
Engineer

By [Signature]

Date 5/22/91

| ITEMIZATION OF QUANTITIES AND COSTS | | | | | | |
|-------------------------------------|----------------------------------|-------------------------|----------------|---------------------------------|-----------------------------|------------------|
| Item | Description | Estimated Plan Quantity | Unit Price Bid | Units of Work Completed to Date | Total Cost of Complete Work | Percent Complete |
| 1 | Mobilization | L.S. | 30,000.00 | 100% | 30,000.00 | 100 |
| 2 | Debris Removal | L.S. | 1,250.00 | 100% | 1,250.00 | 100 |
| 3 | Excavation and Embankment | L.S. | 15,560.00 | 100% | 15,560.00 | 100 |
| 4 | Provide Backfill | 5,820 CY | 4.30 | 5,340 CY | 22,962.00 | 100 |
| 5 | Haul | 2,840 CY | 1.53 | 988 CY | 1,511.64 | 100 |
| 6 | Provide Topsoil | 1,165 CY | 12.30 | 1722 CY | 21,180.60 | 100 |
| 7 | Soil-Clay Liner | 89,550 SF | .33 | 79,621 SF | 26,274.93 | 100 |
| 8 | Geomembrane | 103,650 SF | .73 | 90,327 SF | 65,938.71 | 100 |
| 9 | Geofabric | 103,650 SF | .23 | 90,327 SF | 20,775.21 | 100 |
| 10 | Underlayment | 86,900 SF | .27 | 76,788 SF | 20,732.76 | 100 |
| 11 | Anchormat | 44,300 SF | .65 | 42,000 SF | 27,300.00 | 100 |
| 12 | 3 x 1-1/2 Gravel | 690 CY | 33.21 | 861 CY | 28,593.81 | 100 |
| 13 | 1-3/4 x 1/2 Gravel | 365 CY | 33.21 | 596 CY | 19,793.16 | 100 |
| 14 | Organic Substrate | 4,460 CY | 25.21 | 5392 CY | 135,932.32 | 100 |
| 15 | Sand Substrate | 740 CY | 32.59 | 1,454 CY | 47,385.86 | 100 |
| 16 | Parshall Flume | 5 each | 2,927.00 | 5 | 14,635.00 | 100 |
| 17 | 8" PVC Main/Bypass | 2,590 LF | 9.84 | 2,904 LF | 28,575.36 | 100 |
| 18 | 8" Downflow (Sch 80) | 105 LF | 9.84 | 140 LF | 1,377.60 | 100 |
| 19 | 12" PVC Manifold | 200 LF | 13.53 | 211 LF | 2,854.83 | 100 |
| 20 | 6" PVC Manifold | 200 LF | 7.38 | 120 LF | 885.60 | 100 |
| 21 | 4" Sch 80 PVC (solid) | 2,065 LF | 5.80 | 1,721 LF | 6,539.80 | 100 |
| 22 | 4" Sch 80 Perf PVC | 4,455 LF | 4.70 | 4,456 LF | 20,943.20 | 100 |
| 23 | Acid Resist Valves | 5 each | 1,110.00 | 11 each | 12,210.00 | 100 |
| 24 | Fertilize, Seed, Mulch | 1.95 acre | 500.00 | 3.19 | 1,595.00 | 100 |
| 25 | Lime Application | 1.95 acre | 4,045.00 | .52 acre | 2,103.40 | 100 |
| 26 | Summer Erosion Control (Deleted) | | | | | |
| 27 | Cattails | 1.49 acre | 8,254.00 | 1.93 | 15,930.22 | 100 |
| 28 | Unlined Ditch | 615 LF | 5.55 | 105 LF | 582.75 | 100 |
| 29 | Lined Ditch (Deleted) | | | | | |
| 30 | Rip-Rap | 320 CY | 22.15 | 255 CY | 5,648.25 | 100 |
| 31 | 18" Culvert | 160 LF | 22.75 | 104 LF | 2,366.00 | 100 |
| 32 | Gravel Course | 1,220 LF | 9.06 | 1,430 LF | 12,955.80 | 100 |
| SUBTOTAL | | | | | 614,393.81 | |

ITEMIZATION OF QUANTITIES AND COSTS

| Item | Description | Estimated Plan Quantity | Unit Price Bid | Units of Work Completed to Date | Total Cost of Complete Work | Percent Complete |
|-------------|---|-------------------------|----------------|---------------------------------|-----------------------------|------------------|
| 33 | Provide Water | 112 KGAL | 5.00 | 220,000 G | 1,100.00 | 100 |
| 34 | Flood Wetland | 590 KGAL | 5.00 | 590,000 G | 2,950.00 | 100 |
| 35 | Remove Fence | 680 LF | .65 | 680 LF | 442.00 | 100 |
| 36 | Farm Fence | 2,420 LF | 2.00 | 3018 | 6,036.00 | 100 |
| 37 | Corner Panel | 9 each | 160.00 | 13 | 2,080.00 | 100 |
| 38 | Single Panel | 4 each | 100.00 | 16 | 1,600.00 | 100 |
| 39 | Gates | 64 LF | 8.50 | 128 | 1088.00 | 100 |
| 40 | Backfill Well | L.S. | 400.00 | 100% | 400.00 | 100 |
| 41 | Clean-out Cell Box | L.S. | 2,850.00 | 100% | 2,850.00 | 100 |
| 42 | Manifold Box | L.S. | 2,350.00 | 100% | 2,350.00 | 100 |
| 43 | Remove Structure | L.S. | 1,500.00 | 100% | 1,500.00 | 100 |
| 44 | Additional Fence (CO#1) | 750 LF | .65 | 750 LF | 487.50 | 100 |
| 45 | Off-Site Soils (CO#2) | 3,000 YD | 7.00 | 2,800YD | 19,600.00 | 100 |
| 46 | 4" Main Piping (WD-04) | 170 ft | 9.84 | 170 LF | 1,672.80 | 100 |
| 47 | Chartier Mine Fire (CO #3) | L.S. | 500.00 | 100% | 500.00 | 100 |
| 48 | Railroad Insurance | L.S. | 3,030.00 | 100% | 3,030.00 | 100 |
| 49 | Flume Dimensional Changes | 3.66 CY | 400.00 | 3.66 CY | 1,464.00 | 100 |
| 50 | Restocking Charges | L.S. | 1,500.48 | 100% | 1500.48 | 100 |
| 51 | Extraordinary Freight (Special Orders) | L.S. | 1,107.80 | 100% | 1107.80 | 100 |
| 52 | Locking Caps for Cleanouts | L.S. | 1,231.69 | 100% | 1,231.69 | 100 |
| 53 | Flume Screens-Wier Gate Bolts/Locks | L.S. | 2,289.06 | 100% | 2,289.06 | 100 |
| 54 | Clean and Manifold South Collection Box | L.S. | 997.05 | 100% | 997.05 | 100 |
| 55 | Flume/Liner Sealing | L.S. | 3,935.29 | 100% | 3,935.29 | 100 |
| 56 | Shrub Planting | L.S. | 2,000.00 | 100% | 2,000.00 | 100 |
| 57 | Install Walk-Through Gates | 2 | 175.00 | 2 | 350.00 | 100 |
| | | | | | 62,561.67 | |
| GRAND TOTAL | | | | | 676,955.48 | |

PAY REQUEST NO. 5

ATTACHMENT NO. 1

PROJECT TITLE: FRENCH COULEE WETLAND/ACID MINE DRAINAGE CONTROL

MONT A/E or DSL-AMRB: DSL-AMRB 90-010

CONTRACT DATE: JUNE 28, 1990

OWNER: MONTANA DEPARTMENT OF STATE LANDS - AMR BUREAU

CONTRACTOR: ED BOLAND CONSTRUCTION, GREAT FALLS, MT 59401

| CHANGE ORDERS | | |
|----------------------------|---|-----------------------------------|
| NO. | DESCRIPTION | AMOUNT <i>(dollars)</i> |
| 1 | Additional fence reimbursement | 487.50 |
| 2 | Off-site soils | 12,400.00 |
| 3A | Chartier mine fine | 500.00 |
| 4 | Flume finishing and security/south collection box | 10,803.70 |
| TOTAL CHANGE ORDERS | | 24,191.20 |

SCHEDULE OF MATERIAL ON SITE

PROJECT TITLE: FRENCH COULEE WETLAND/ACID MINE DRAINAGE CONTROL

DSL-AMRB: 90-010

CONTRACTOR: ED BOLAND CONSTRUCTION

| | | |
|----------------|---|------------------|
| Item <u>23</u> | Material Delivered <u>Acid Resistive Valve, Valve Box, Riser and Stem Extension</u> | |
| | Material in Place <u>11 each</u> | |
| | Material on Site <u>1 each</u> | \$ <u>732.00</u> |

TOTAL MATERIAL ON SITE \$ 732.00
(Attach applicable invoices or bills of lading)

Requested by: Ed Boland Construction
(Contractor)

To be included in Payment Request No. 5.

ATTACHMENT 4

ANALYSIS of CONSULTANT COSTS INCURRED

**ANALYSIS OF CONSULTANT COSTS INCURRED
 FOR THE MONTANA DEPARTMENT OF STATE LANDS
 ABANDONED MINE RECLAMATION BUREAU
 DSL/AMRB PROJECT NUMBER: 90-010
 DATE OF PREPARATION: NOVEMBER 27, 1991**

| Engineering Service | Amount |
|--|--------------------------|
| Design Engineering 1989 AMR Contract | \$ 78,574.91 |
| SUBTOTAL DESIGN ENGINEERING COST: | \$ 78,574.91 |
| Construction Engineering and Project Administration Cost 1990 Subcontract to Peccia and Associates 1991 AMR Contract | 60,034.32 1,982.00 |
| SUBTOTAL CONSTRUCTION ENG. COST: | \$ 62,116.32 |
| PROJECT ENGINEERING COST: | \$ 140,691.23 |
| CONSTRUCTION COST: | \$ 677,687.48 |

| | |
|---|--------|
| Design Engineering/Construction Cost Ratio: | 11.6 % |
| Construction Engineering/Construction Cost Ratio: | 9.2 % |
| Total Engineering Cost/Construction Cost Ratio: | 20.8 % |

ATTACHMENT 5
AS-BUILT DRAWINGS

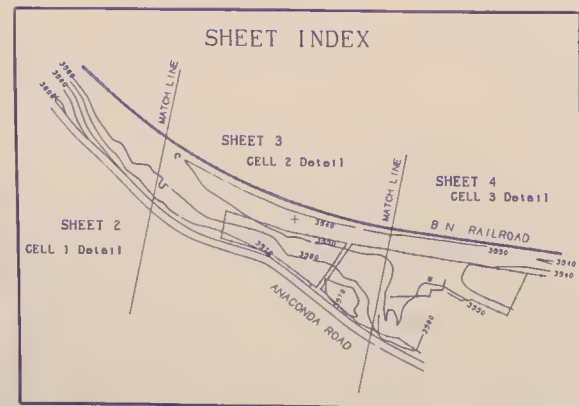
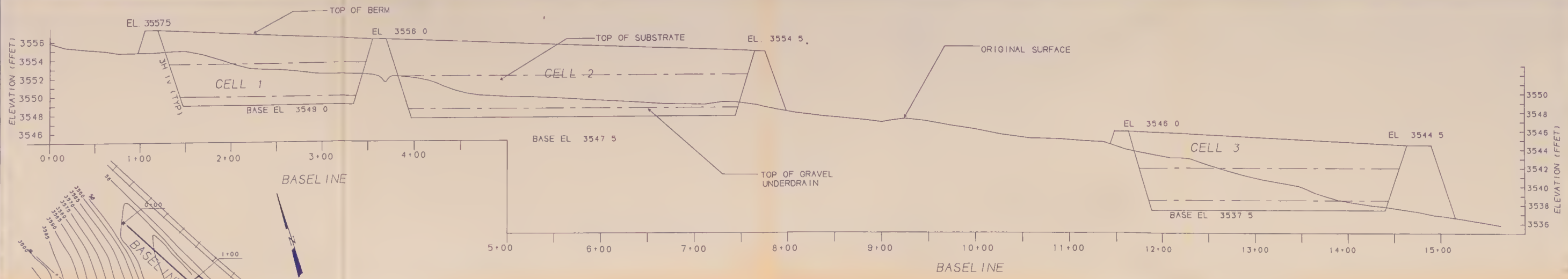

- SYMBOL LEGEND**
- ACTIVE RAIL LINE
 - CLEAN-OUT
 - AMD INFLUENT PIPE
 - SOIL BORING
 - OVERHEAD POWER LINE (POLES SHOWN)
 - FENCE
 - U/G TELEPHONE

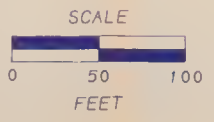

RECEIVED
DEC 20 1991
STATE LANDS

| | | | |
|--|---|----------------------------|---|
| Schafer and Associates P O Box 8188 Bozeman MT 59716 (406) 687-3476 | | | FRENCH COULEE WETLAND CASCADE CO., MT |
| SHEET 1: PLAN AND PROFILE, AS BUILT | | | |
| CLIENT: MT DEPT. OF STATE LANDS (41-12) | LOCATION: NW1/4, SE1/4 SECT 28, T19N, R8E | DRAWING NUMBER: FC5/CADD83 | REVISION NUMBER: 2 |
| SHEET 1 OF 6 | DATE: Nov 26, 1991 | SCALE: 1 in. = 50 ft | DRAWN BY: DA/TH |
| | | CHECKED BY: | |

1 INCH PARSHALL FLUME -
LEVEL OF INLET 2 FEET BELOW
TOP OF BIRM

TOPSOIL OUTSIDE FACE TOP AND
INSIDE OF CELL TO LEVEL OF SUBSTRATE
WITH 8 INCH LIFT

NOTE BASE GRADE CORRSponds
TO TOP OF SOIL-CLAY LINER

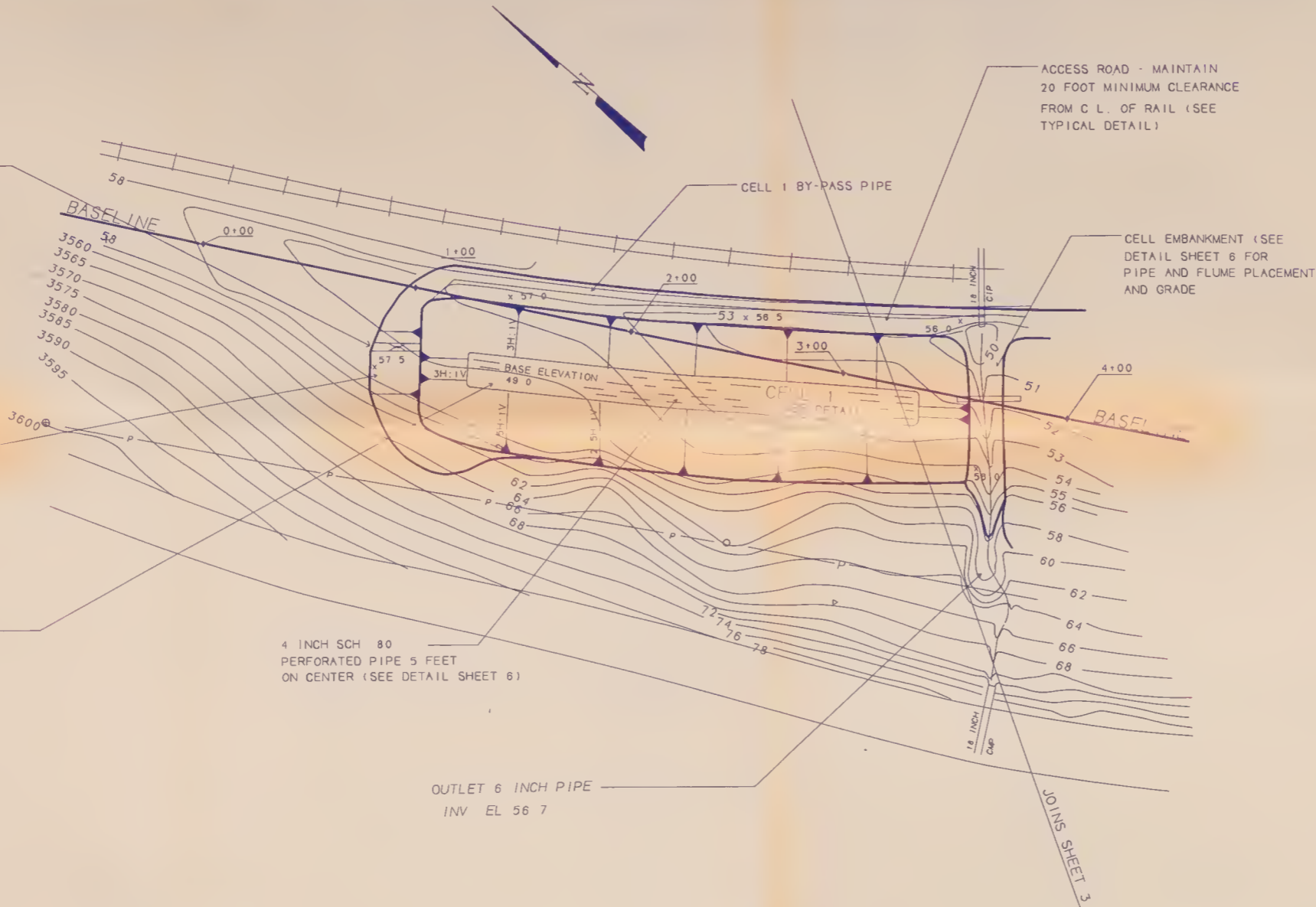

TYPICAL CELL CROSS-SECTION

(STATION 6+70)

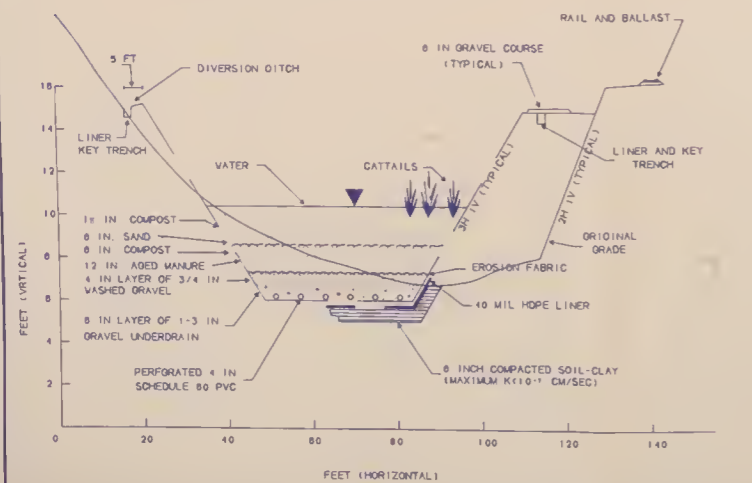

ACCESS ROAD DETAIL

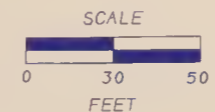
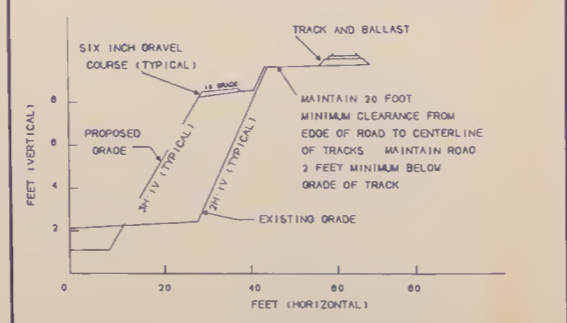

- SYMBOL LEGEND
- ACTIVE RAIL LINE
 - AMD INFLUENT PIPE
 - SOIL BORING
 - OVERHEAD POWER LINE (POLES SHOWN)
 - FENCE
 - U/G TELEPHONE

RECEIVED
DEC 20 1991
STATE LANDS

| | | | |
|--|---|----------------------------|--|
| Schafer and Associates P.O. Box 0100 Bozeman, MT 59716 (406) 587-3478 | | | FRENCH COULEE WETLAND CASCADE CO., MT |
| SHEET 2: CELL 1 PLAN, AS BUILT | | | |
| CLIENT: MT. DEPT. OF STATE LANDS | LOCATION: NW1/4, SE1/4 Sect 26, T19N, R6E | DRAWING NUMBER: FC4/CADD83 | REVISION NUMBER: 2 |
| SHEET 2 OF 6 | DATE: Nov 28, 1991 | SCALE: 1 in : 30 ft | DRAWN BY: DA/TH CHECKED BY: |

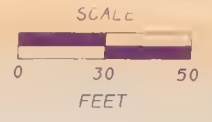
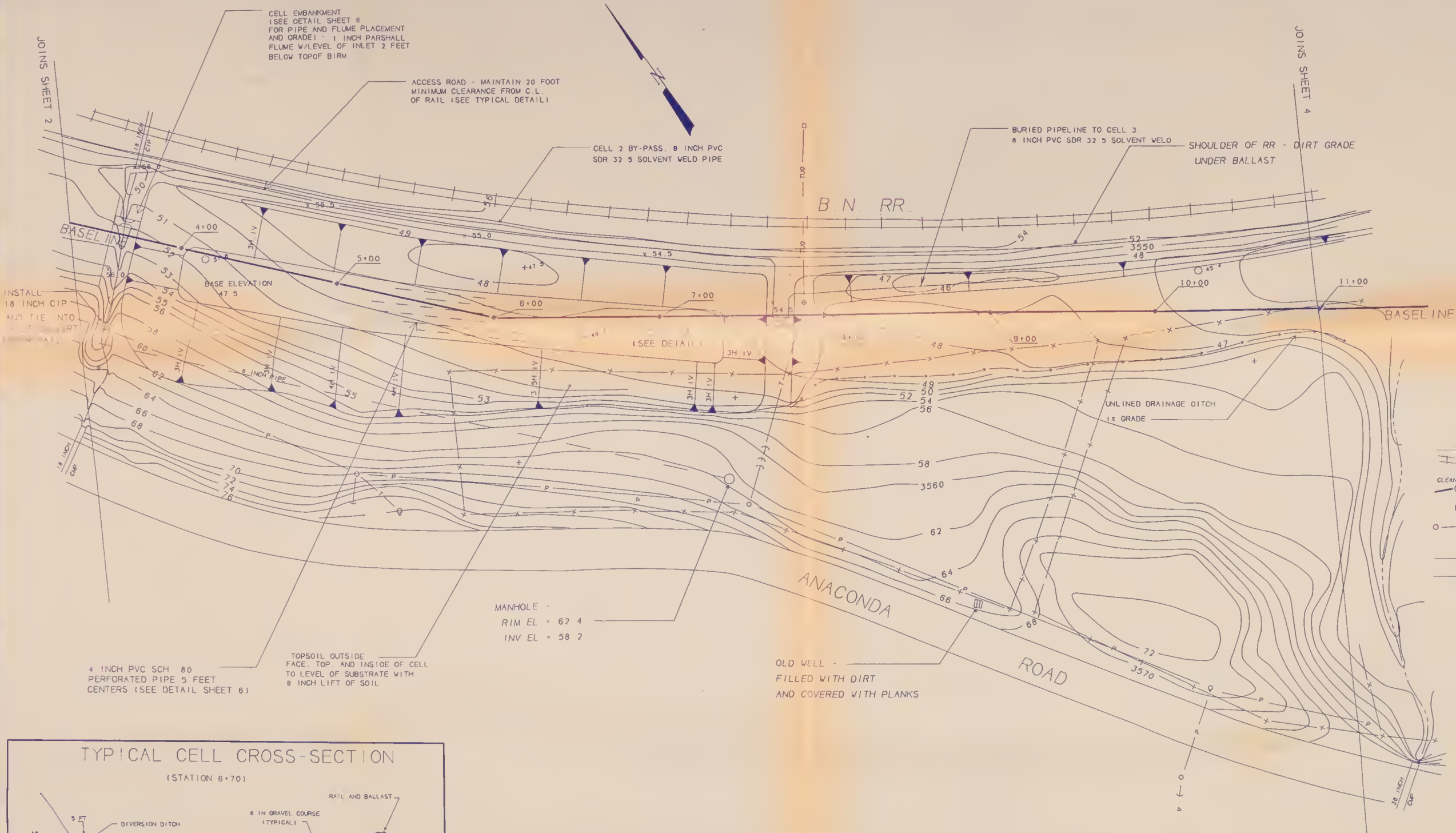

- SYMBOL LEGEND
- ACTIVE RAIL LINE
 - AMD INFLUENT PIPE
 - SOIL BORING
 - OVERHEAD POWER LINE (POLES SHOWN)
 - FENCE
 - U/G TELEPHONE

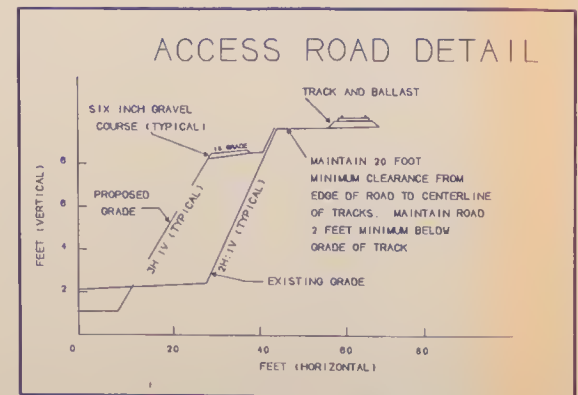
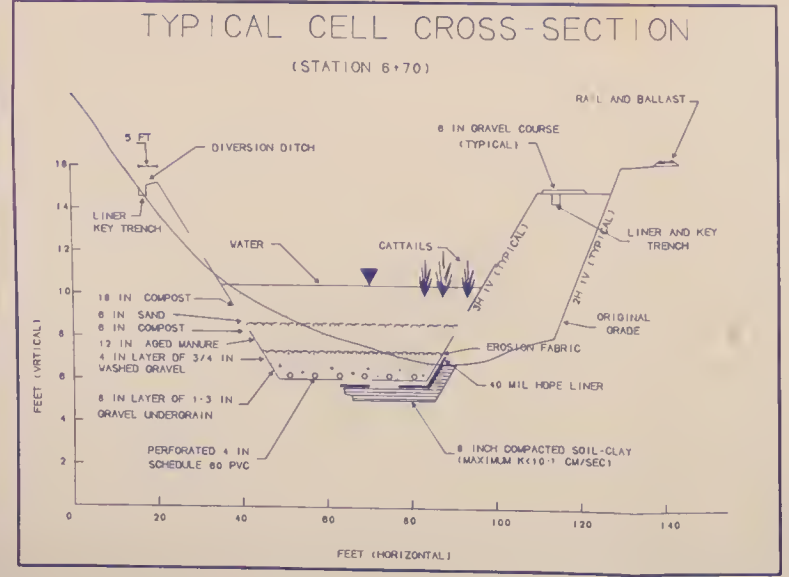

RECEIVED
DEC 20 1991
STATE LANDS

Schofer and Associates
P O Box 6186
Bozeman MT 59716
(406) 567-8476



FRENCH COULEE WETLAND
CASCADE CO., MT

SHEET 3: CELL 2 PLAN, AS BUILT

| | |
|----------------------------------|---|
| CLIENT: MT. DEPT. OF STATE LANDS | LOCATION: NW1/4, SE1/4 Sect 26 T19N R8E |
| SHEET 3 OF 6 | DRAWING NUMBER: FC2/CADD84 |
| DATE: Nov 28, 1991 | SCALE: 1 in = 30 ft |
| | REVISION NUMBER: 2 |
| | DRAWN BY: DA/TH |
| | CHECKED BY: |

JOINS SHEET 3

CELL EMBANKMENT (SEE DETAIL SHEET 6 FOR PIPE AND FLUME PLACEMENT AND GRADE)

ACCESS ROAD - MAINTAIN 20 FOOT CLEARANCE FROM C.L. OF RAIL (SEE TYPICAL DETAIL)

NOTE: BASE GRADE CORRESPONDS TO TOP OF SOIL-CLAY LINER

B.N. RAILROAD

BOX CULVERT APPROX 5 FT WIDE BY 4 3 FT HIGH - INV EL 29 0

1 1/2 INCH PARSHALL FLUME LEVEL OF INLET 2 FEET BELOW TOP OF BIRM

TOPSOIL OUTSIDE, TOP, AND INSIDE OF CELL TO LEVEL OF SUBSTRATE WITH 8 INCH SOIL LIFT

UNLINED DPA NAGE DITCH 1/2 GRADE

CELL 3 (SEE DETAIL)

4 INCH PVC SCH 80 PERFORATED PIPE (SEE SHEET 6), 6 FEET ON CENTER

REMOVE AND REPLACE STORAGE SHED

RIP-RAP LINED DRAINAGE CHANNEL

ANACONDA ROAD

TYPICAL CELL CROSS-SECTION (STATION 6+70)

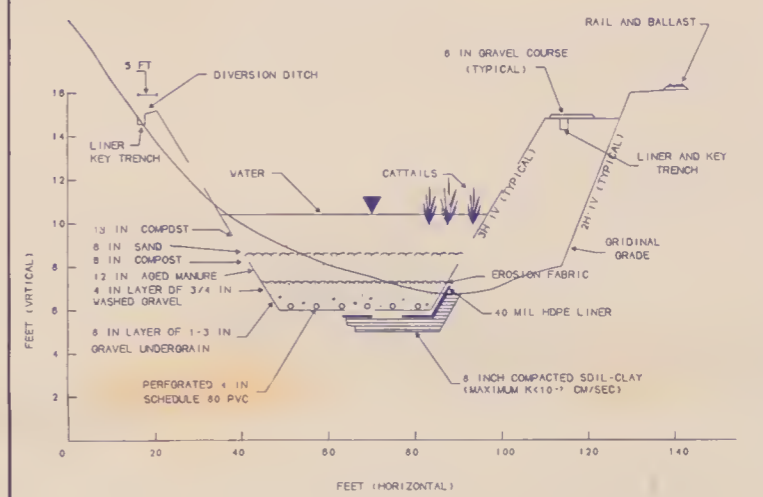

SYMBOL LEGEND

- ACTIVE RAIL LINE
- AMD INFLUENT PIPE
- SOIL BORING
- OVERHEAD POWER LINE (POLES SHOWN)
- FENCE
- U/G TELEPHONE

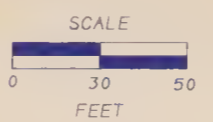

ACCESS ROAD DETAIL

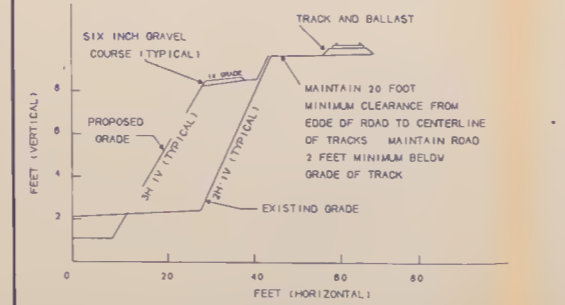

RECEIVED
DEC 20 1991
STATE LANDS

Schafer and Associates
P.O. Box 0100
Bozeman MT 59716
(406) 687-3478



FRENCH COULEE WETLAND
CASCADE CO., MT

SHEET 4: CELL 3 PLAN, AS BUILT

| | |
|--|---|
| CLIENT: MONT. DEPT. OF STATE LANDS 41-12 | LOCATION: SW1/4, SE1/4 SECT 26, T19N, R9E |
| SHEET 4 OF 6 | DRAWING NUMBER: FC3/CADD83 |
| DATE: Nov 26, 1991 | SCALE: 1 IN. = 30 FT |
| | DRAWN BY: DA/TH |
| | CHECKED BY: |

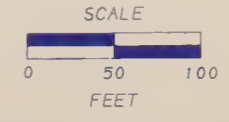
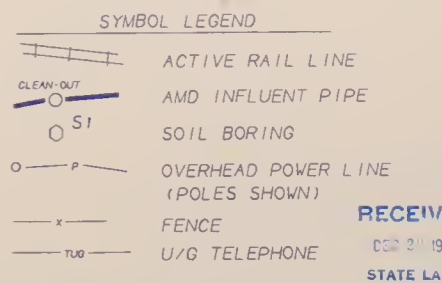
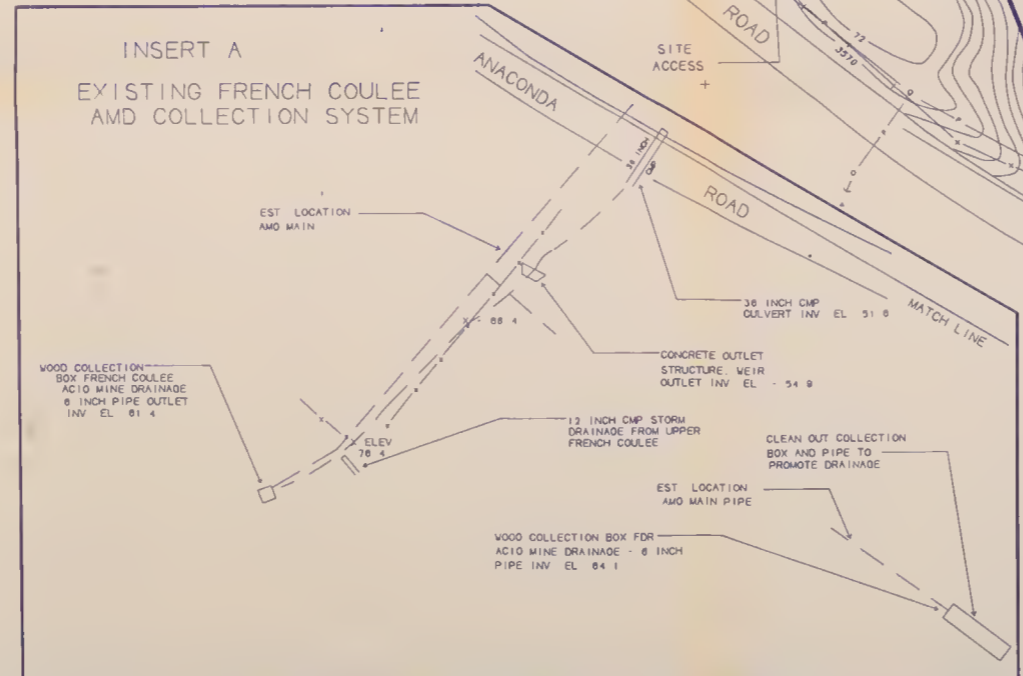
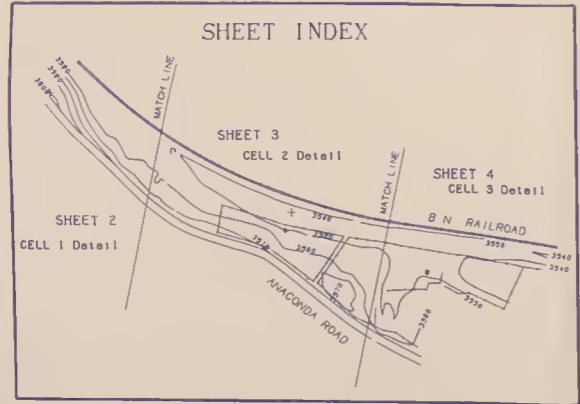
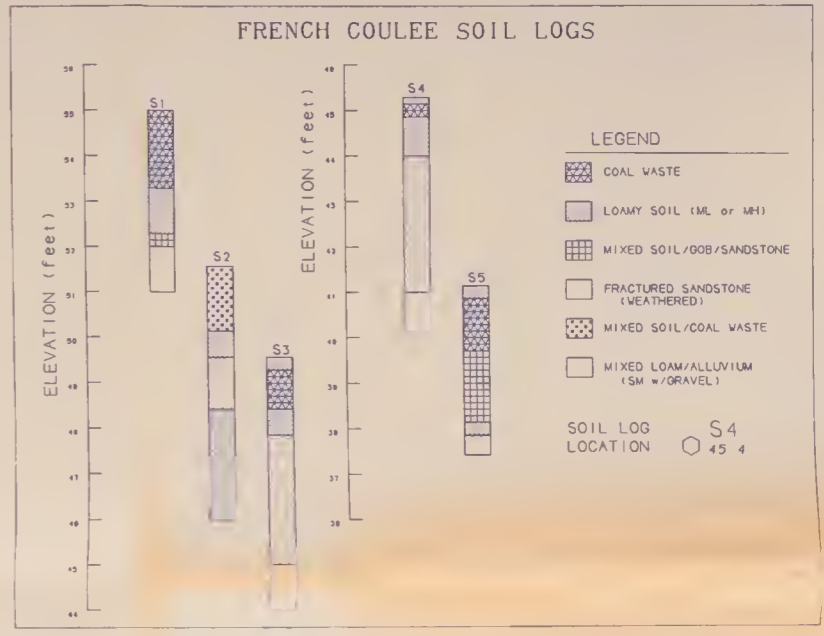
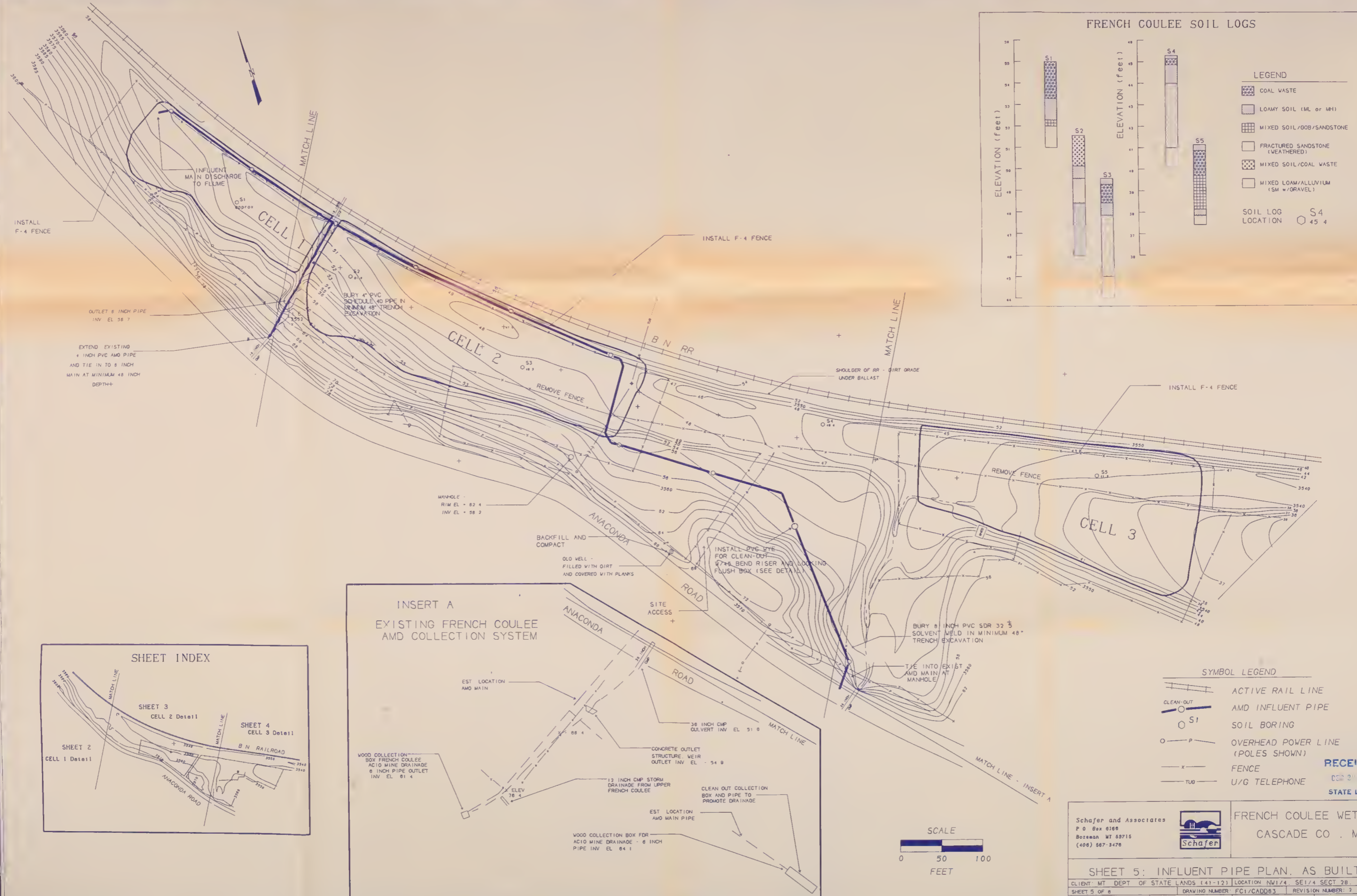

Schafer and Associates
P O Box 0100
Bozeman MT 59715
(406) 587-3478

FRENCH COULEE WETLAND
CASCADE CO., MT

SHEET 5: INFLUENT PIPE PLAN, AS BUILT

CLIENT: MT DEPT OF STATE LANDS (41-12) LOCATION: NW1/4, SE1/4, SECT 28, T19N, R8E
SHEET 5 OF 6 DRAWING NUMBER: FC1/CADD83 REVISION NUMBER: 2
DATE: Oct 11, 1991 SCALE: 1 in = 50 ft DRAWN BY: DA/TH CHECKED BY:

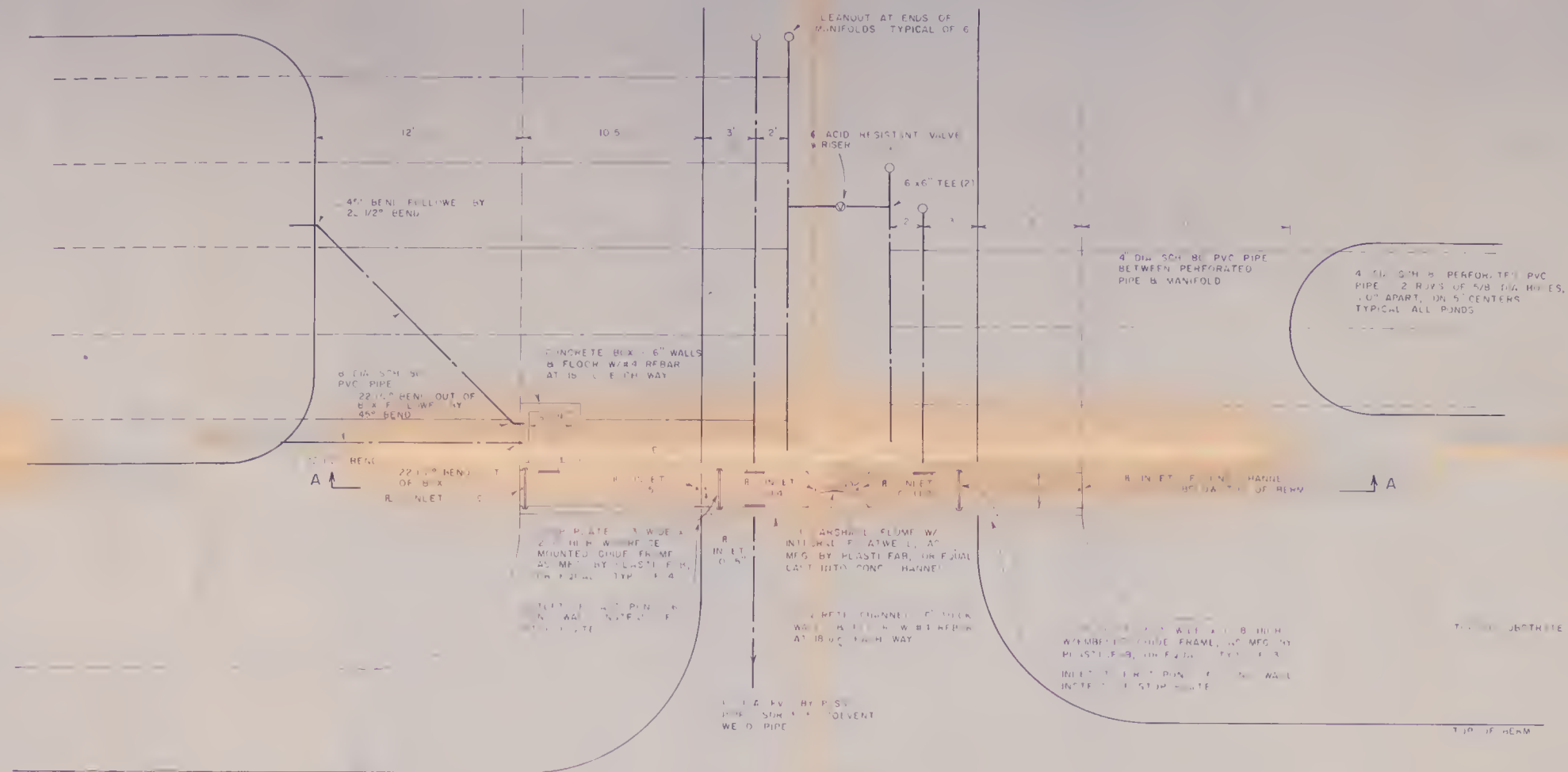

PLAN VIEW

TYPICAL 1/2" GAP BETWEEN PIPES

NOTE: THE 1/2" GAP OF ALL OPENINGS IN THE CHANNEL, WALL, F.H. MANIFOLD PIPE, BY-PASS PIPE, ETC., SHALL BE SET 2" ABOVE THE BOTTOM OF THE CHANNEL.

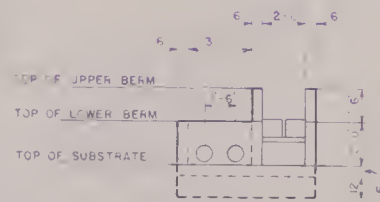

SEC. B-B

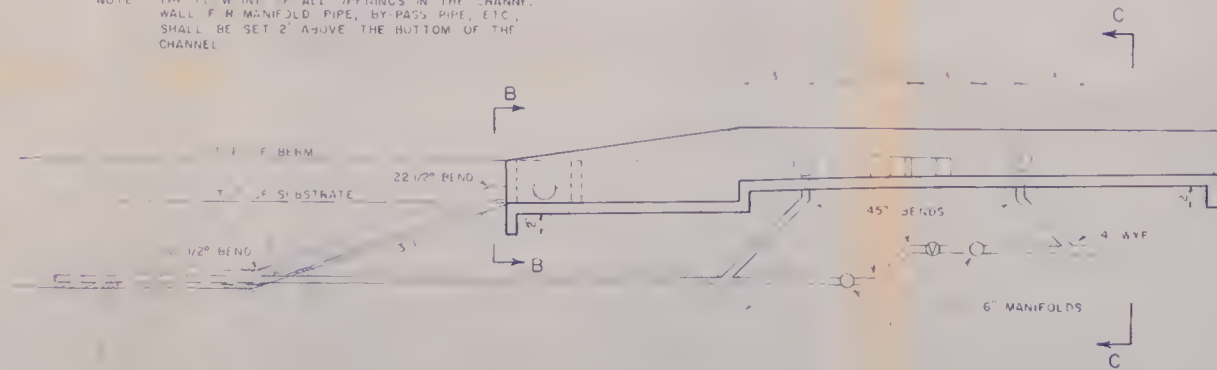

SEC. A-A

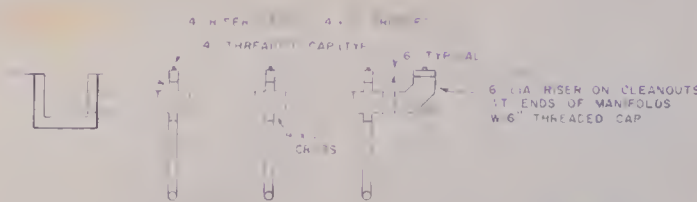

SEC. C-C

RECEIVED
DEC 21 1991
STATE LANDS



Schafer and Associates
P.O. Box 6186
Bozeman, MT 59715
(406) 597-3478



FRENCH COULEE WETLAND
CASCADE CO., MT

| | |
|------------------------------|--------------------|
| 6 | HYDRAULICS DETAILS |
| LOCATION: CASCADE COUNTY, MT | REVISION NUMBER |
| SCALE: 3/8" = 1'-0" | CHECKED BY: RC |

END OF QUARTER

1900 16 BOUND

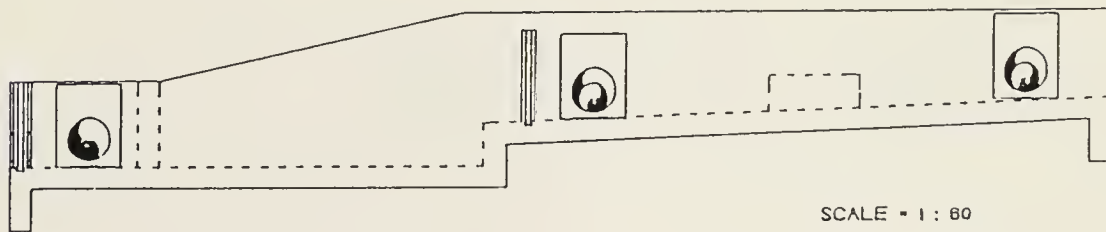
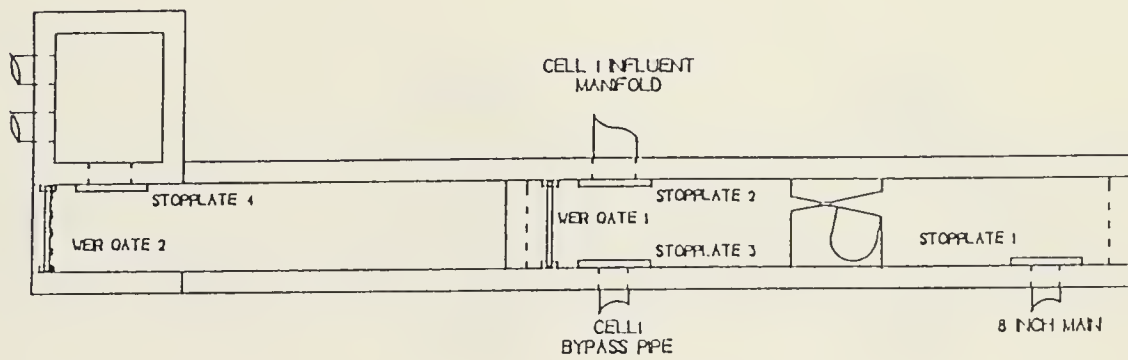

SCALE = 1 : 60



FRENCH COULEE WETLAND
 SUPPL. DWG. 1a: CELL 1 INFLUENT FLUME

NOVEMBER 20, 1991

CADD65/1A

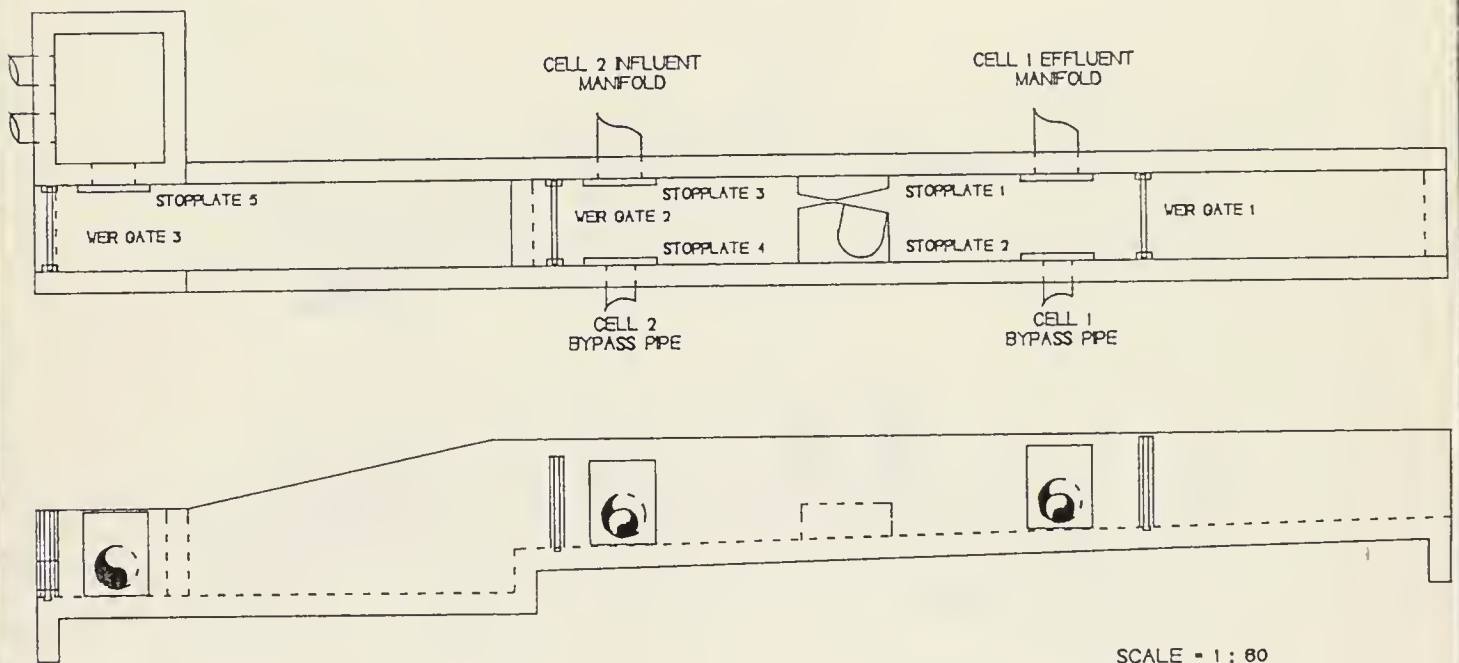

SCALE = 1 : 80



FRENCH COULEE WETLAND
 SUPPL. DWG. 1b: CELL 2 INFLUENT FLUME

NOVEMBER 20, 1991

CADD65/1B

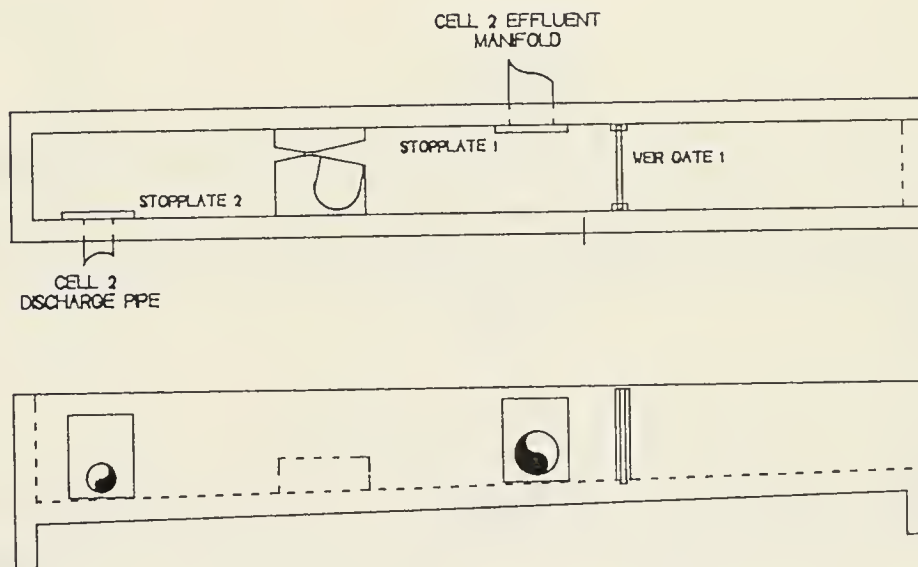

SCALE = 1 : 60



FRENCH COULEE WETLAND
 SUPPL. DWG. 1c: CELL 2 EFFLUENT FLUME

NOVEMBER 20, 1991

CADD65/1C

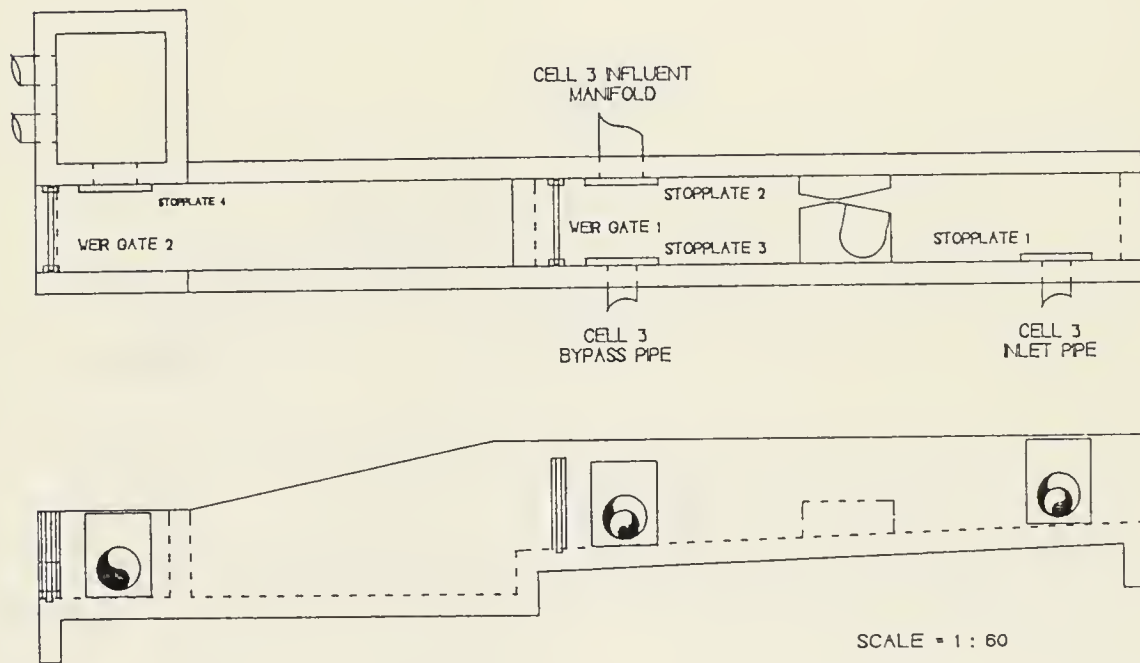

FRENCH COULEE WETLAND

SUPPL. DWG. Id: CELL 3 INFLUENT FLUME

NOVEMBER 20, 1991

CADD65/ID

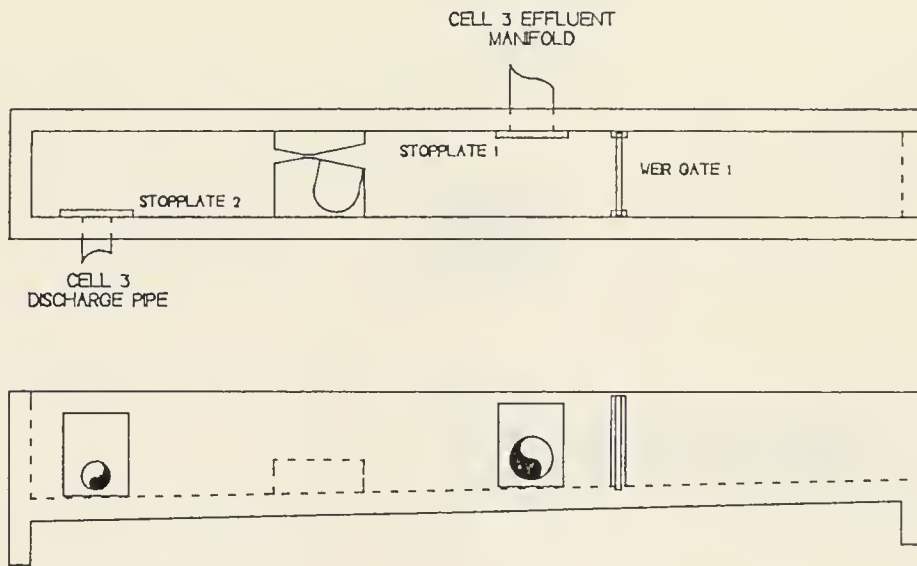

SCALE = 1 : 60



Schafer

FRENCH COULEE WETLAND

SUPPL. DWG. 1e: CELL 3 EFFLUENT FLUME

NOVEMBER 20, 1991

CADD65/1E

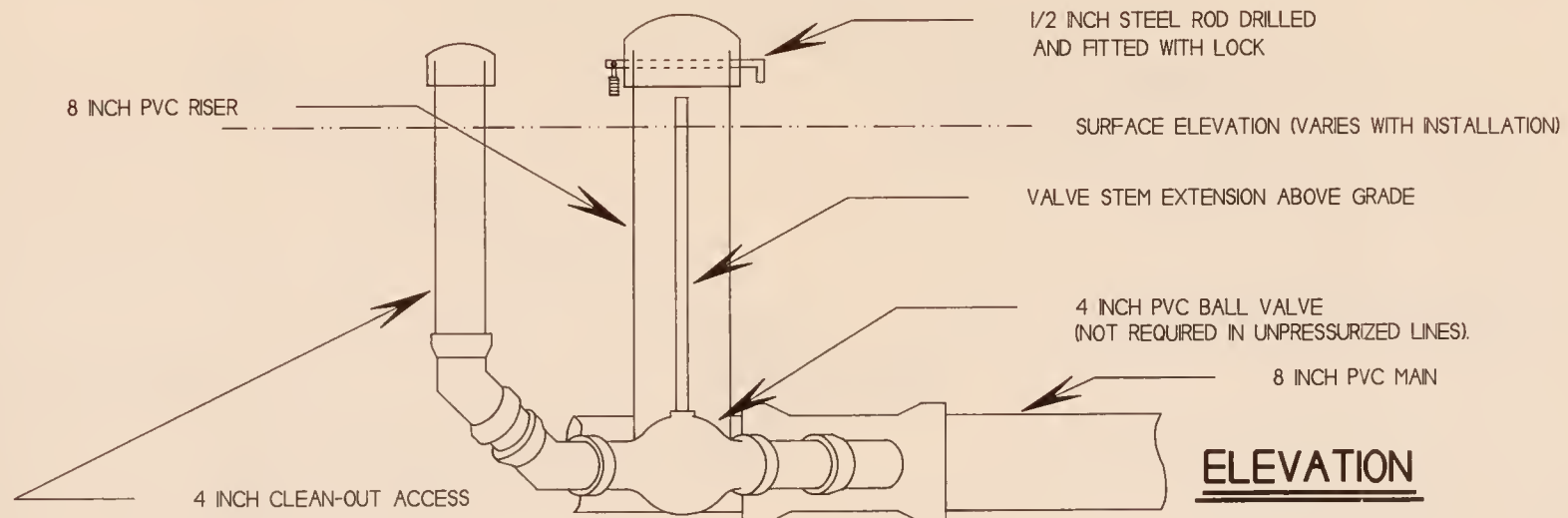

ELEVATION

PLAN

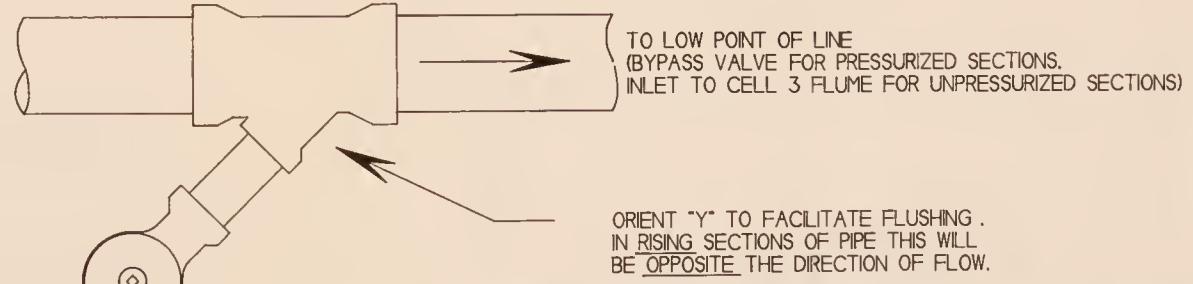

| | | |
|--|---|---|
| <p>Schafer and Associates P.O. Box 6186 Bozeman, MT 68716 (406) 687-8478</p> |  | <p>FRENCH COULEE WETLAND</p> |
|--|---|---|

SUPPL. DRW. 2: 8 INCH MAIN CLEANOUT DETAILS

| | | | |
|-------------------------|---------------------------------|-------------------------|-------------|
| CLIENT: DSL/AMRB 90-010 | | LOCATION: BELT, MONTANA | |
| SHEET OF | DRAWING NUMBER: CA0065/CLEANOUT | REVISION NUMBER: 0 | |
| DATE: Nov. 26, 1991 | SCALE: | DRAWN BY: TH | CHECKED BY: |

8 INCH MAIN BELOW.
CELL 1 AND CELL 2 BYPASS ABOVE

PRESSURIZED CLEANOUT (TYPICAL of 10)
SHUT-OFF VALVE REQUIRED
(SEE SUPPLEMENTAL DRAWING 2 FOR DETAIL)

8 INCH PIPE, CELL 2 TO CELL 3

UNPRESSURIZED CLEANOUT (TYP of 3)
SHUT-OFF VALVE NOT REQUIRED

4 INCH TIE IN AT CULVERT

8 INCH MAIN BYPASS TO CELL 3
(SEE DETAIL BELOW)

CELL 3 BYPASS PIPE

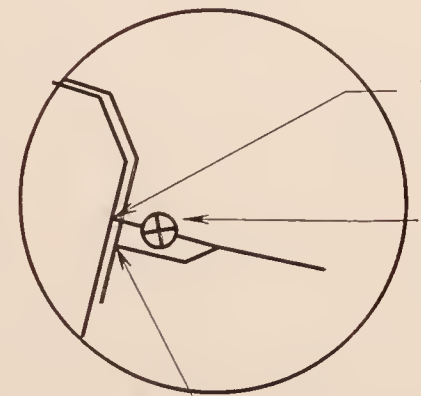

TIE IN TO 8 INCH MAIN
IN TRENCH BELOW

8 INCH MAIN BYPASS VALVE

TIE IN TO CELL 2 BYPASS
AND CELL 2 DISCHARGE
IN TRENCH ABOVE

8 INCH TIE IN AT MANHOLE

Schafer and Associates
P.O. Box 6180
Bozeman, MT 59716
(406) 587-8478



FRENCH COULEE
WETLAND

SUPPL. DRW. 3: COLLECTION PIPING DETAILS

| | | |
|-------------------------|--------------------------------|--------------------|
| CLIENT: DSL/AJRB 90-010 | LOCATION: BELT, MONTANA | |
| SHEET OF | DRAWING NUMBER: CADDOS/P IPING | REVISION NUMBER: 0 |
| DATE: Nov. 28, 1991 | SCALE: | DRAWN BY: TH |
| | | CHECKED BY: |

ATTACHMENT 6
PHOTOGRAPHS and SLIDES

LIST OF PHOTOS

- A1 Allis Chalmers 7045 tractor pulling the rototiller.
- A2 Wagner scraper-hauler used for earthwork, bentonite application and road construction.
- A3 Dynapac vibratory compactor finishing compaction of a cell floor.
- A4 The Dynapac works on the end of cell 1 while a backhoe excavates buried manifold prior to tying in 8 inch main.
- A5 A Case W14 loader used for cell substrate placement here shown delivering topsoil.
- A6 A JD544-B bringing gravel into a cell.
- A7 An end dump longbed trailer used to haul Eko-Compost from Missoula. This trailer tipped over while emptying and was destroyed.
- A8 A walking floor trailer carried larger loads and was much safer to operate for Eko-Compost delivery.
- B1 200 mesh bentonite was delivered in nominal one ton bags and stored on site.
- B2 Bags were emptied into the hopper of the scraper hauler using the C225 trackhoe.
- B3 The scraper hauler applying bentonite to a mix area. A spreader proved to be unworkable because of a tendency to bridge in the hopper and severe dusting during application.
- B4 It was possible to get fairly uniform bentonite application using a scraper hauler for application. Total application thickness was approximately 3/4 inch. An experienced operator was essential to obtain uniform application.
- B5 Areas getting too heavy application were respread with a small dozer or raked out by hand.
- B6 Rototilling bentonite into the soil.
- B7 Water application to get moisture content up to optimum before bentonite application.
- B8 Dozing bentonite-soil mixture into place on a sideslope.
- C1 Sampling coarse gravel.

- C2 Moisture testing of soil prior to bentonite application.
- C3 Soil-bentonite layer is clearly visible over an excavated distribution pipe stub.
- C4 Measuring liner installation.
- C5 Excavating buried distribution piping after soil bentonite liner placement.
- C6 Exposed distribution piping from a manifold ready for extension into the cell bottom.
- C7 Perforated piping installed in the bottom of cell 2.
- C8 A close-up of perforated (and unperforated) 4 inch PVC pipe used for distribution piping.
- D1 Backfilling a "V" trench following liner installation.
- D2 Unspooling a sheet of HDPE liner for installation over the soil-bentonite liner.
- D3 Making a seam between two sheets of HDPE liner with an automatic seaming machine.
- D4 Close-up of a manually welded joint in HDPE.
- D5 Distribution pipe extensions were sealed with an HDPE boot, silicone cement and a stainless steel hose clamp.
- D6 Protective geofabric installed over the HDPE liner.
- D7 Fabricating an HDPE boot.
- D8 A finished boot seal.
- E1 "V" trench for anchoring liner materials.
- E2 Sandbags were used to hold materials in place.
- E3 Cell 1 ready for distribution pipe installation. Note that wind has damaged Enkamat erosion fabric because of a lack of sandbagging.
- E4 Fitting boots over pipe.
- E5 Manual welding for completion of a boot installation.
- E6 Fabricating an HDPE boot.

- E7 Seaming two sections of geofabric.
- E8 Compacting the backfill in a liner trench.
- F1 Starting the substrate filling process in a corner of a cell with a temporary ramp and coarse gravel.
- F2 Extending the temporary ramp into the cell bottom.
- F3 Requirements for materials storage areas were considerable during the cell filling process.
- F4 Bringing the first lift of gravel into the cell.
- F5 Fine gravel installation completed in cell 2.
- F6 Cell 1 was constructed somewhat differently than the other cells in that several lifts of material were under construction at the same time. Here one can see coarse gravel, fine gravel, coconut fiber mat, manure and Eko-Compost.
- F7 A loader emptying a load of substrate materials.
- F8 C225 trackhoe spreading substrate.
- G1 The liner was cut and folded back to provide access for flume construction.
- G2 Establishing grades for flume construction.
- G3 Formwork for flume construction.
- G4 Parshall flume insert and other embedments and pipe penetrations were placed prior to concrete pour.
- G5 Pouring concrete into a form.
- G6 End view of a form showing two pipe penetrations.
- G7 A stopplate with screen covering the opening.
- G8 A finished flume.
- H1 A temporary ramp access to one of the cells.
- H2 An overview of cell 2 during construction.
- H3 Materials storage area during the peak of cell construction.

- H4 A laser is used to hold grade during bypass pipe installation.
- H5 Cells 1 and 2 nearing completion.
- H6 The storage area and cell 3 nearing completion.
- H7 Scarifying an area that had been heavily compacted during construction.
- H8 The liner was attached to the flume with stainless steel battens and sealed with neoprene rubber sealant.
- I1 A view of cell 3 during liner installation with rip-rapped channel to the right.
- I2 Rip-rapped channel leaving the construction area on the east side of the project.
- I3 A view of the rip-rapped channel on the south side of cell 3.
- I4 C225 trackhoe placing rip-rap.
- I5 Installation of a manifold in cell 1.
- I6 Using a Bulldog compactor to consolidate fill in a pipe trench.
- I7 A completed manifold installation.
- I8 Installing perforated pipe in the bottom of cell 1.
- J1 Small dikes were constructed on the surface of cells to minimize short circuiting of water across the surface.
- J2 Hand planting cattails in the substrate.
- J3 Cattails were planted 4 to 6 inches below the surface.
- J4 An overview of cattail planting.
- J5 Cell 2 is flooded.
- J6 An overview of the site at completion of the project.
- J7 Mustard, carried in with topsoil, emerged along with the grasses which were seeded.
- J8 Typical fence installation on the project.



A2



A3



A4

A6



A8



A5



A7



DATE _____ NO. _____
TITLE _____

Photo-Saver
Made in U.S.A.

vue-all
ARCHIVAL



B1



B2



B3



B4

B6



B8



B6



B7







C6

C6

C8

C7

NO.

DATE

TITLE



D1



D2

8



D3



D4

Photo-Saver

Made in U.S.A.

vue-all
ARCHIVAL



D5



D6



D7

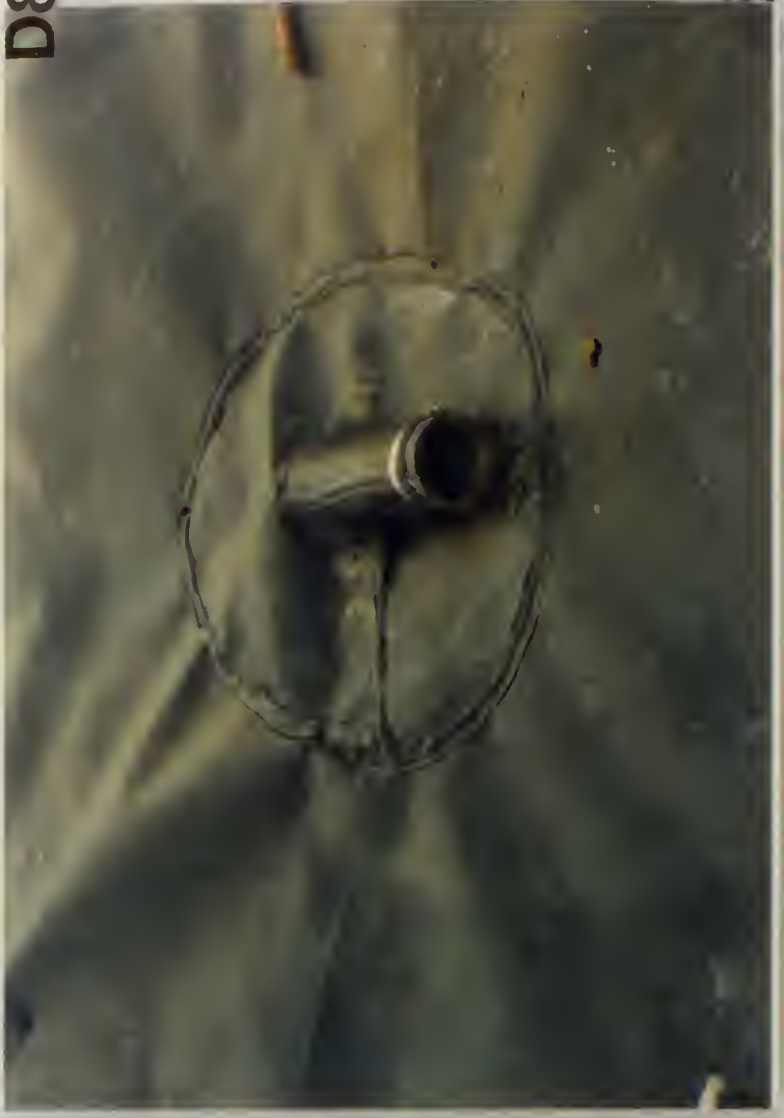

D8

DATE _____ NO. _____

TITLE _____

Photo-Saver
Made in U.S.A.

VUE-ALL
ARCHIVAL



E1



2

3

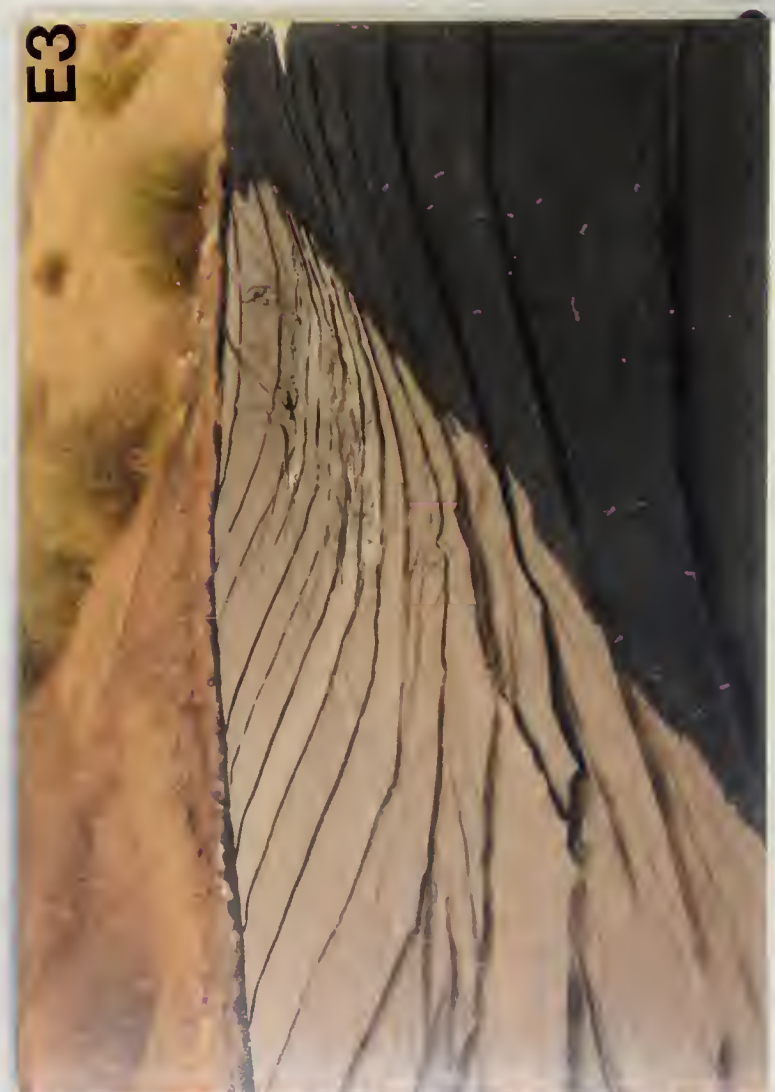

E3



E4

4



E5



E6



E7



E8



F2

3



F3



F4

1

F5



F6



F7



F8



NO.

DATE

TITLE

Photo-Saver
Made in U.S.A.

vue-all
ARCHIVAL



G1



G2



G3



G4

G5



G7



G8



DATE _____

NO. _____

TITLE _____

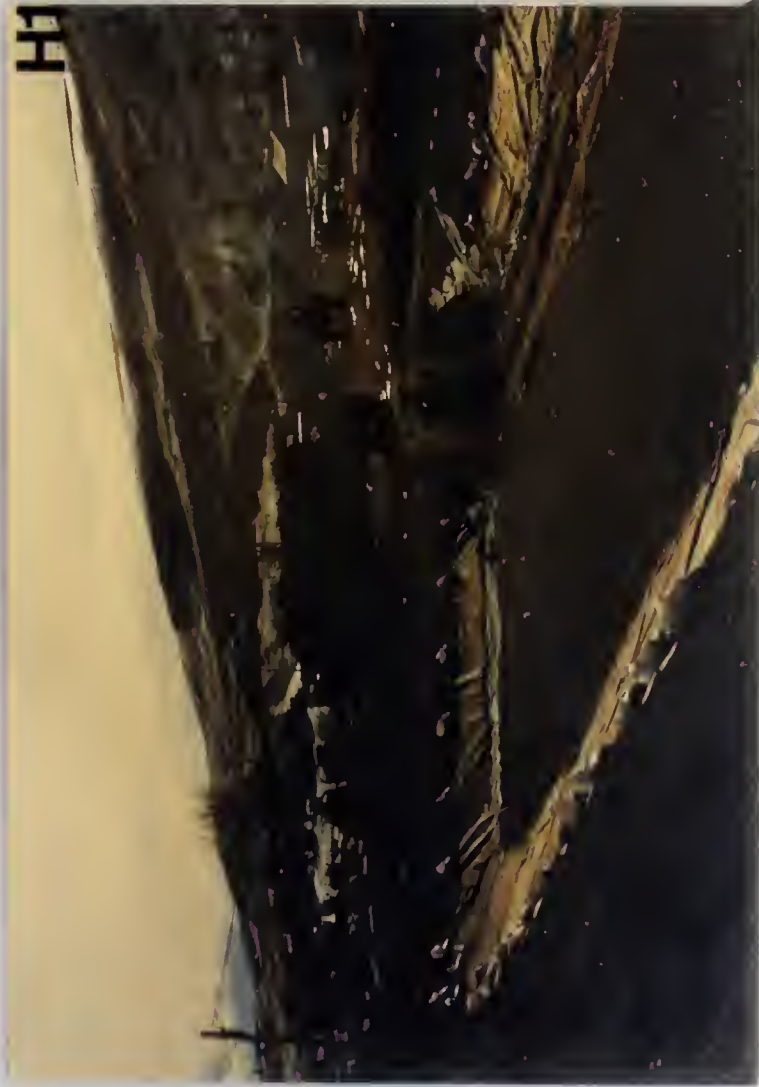

H1



H2

8

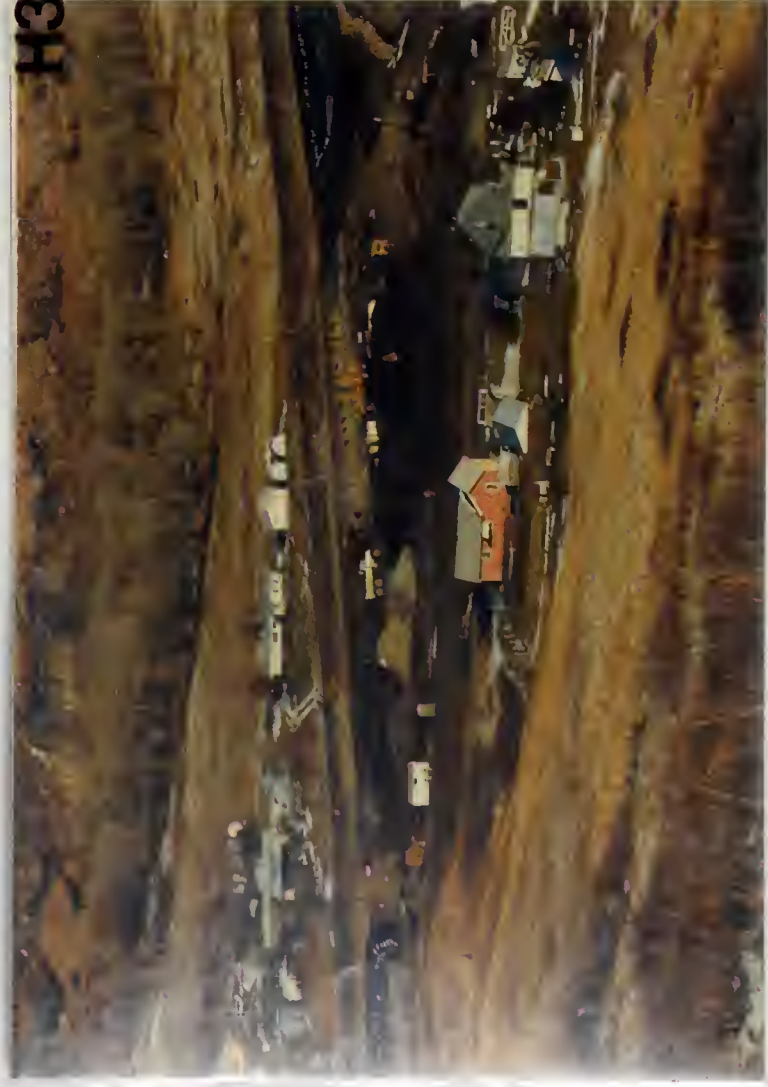

H3



H4

3

H5



H6



H7



H8



DATE _____
TITLE _____

NO. _____

11



12



13



14

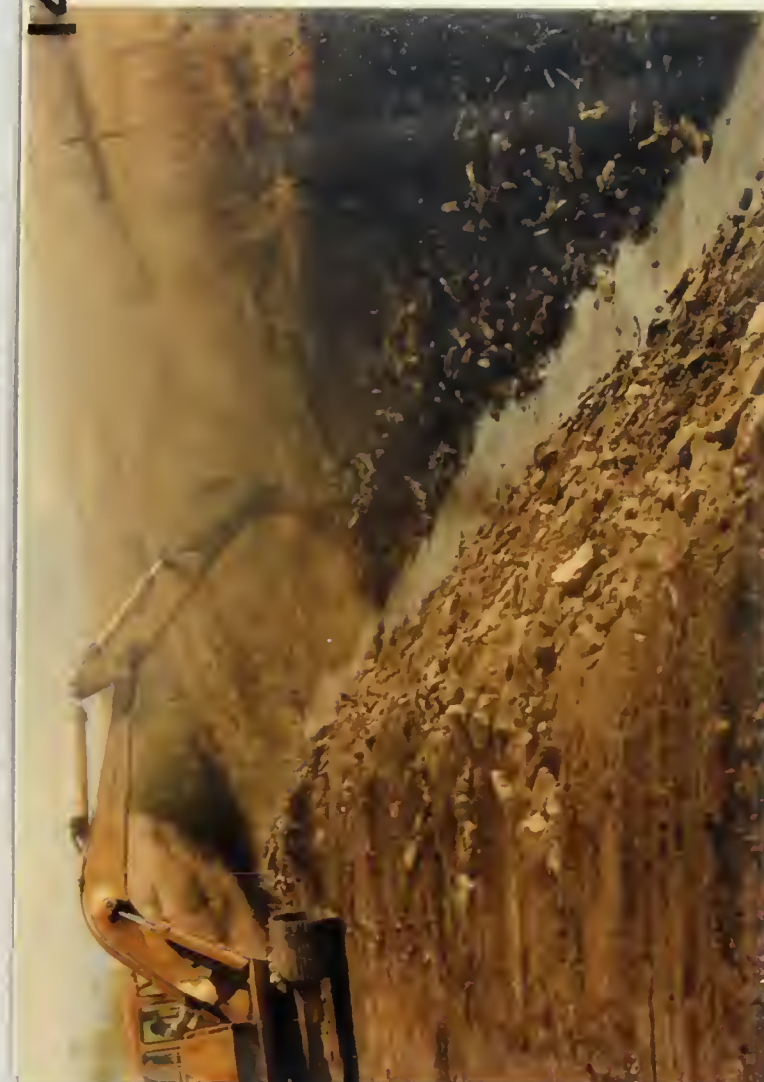

16



18



15



17





J1



J2

8



J3



J4

3



J6

J4

J8

J5

J5

J7

ATTACHMENT 7
OTHER PROJECT DOCUMENTS

RECEIVED MAY 8 - 1990

CITY OF BELT

BELT, MONTANA 59412

PHONE 277-3621

MAY 4, 1990

Ed Spotts
Schafer & Associates
P.O. Box 6186
Bozeman, Montana 59715

Dear Ed:

The attached Right of Entry Form is sent per your recent request. We do understand that the Town of Belt still reserves the right to review and approve all final plans and locations prior to the letting of bids and/or start of any construction on the proposed wetlands.

Thanks for your assistance in this project.

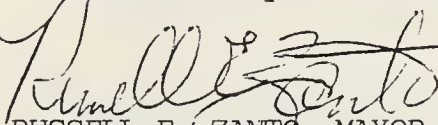
RUSSELL E. ZANTO, MAYOR
TOWN OF BELT

CONSENT FOR RIGHT OF ENTRY/RECLAMATION

I/We, CITY OF BELT, the Owner(s) of record of the following described property:

do hereby grant to the Office of Surface Mining Reclamation and Enforcement, U.S. Department of the Interior (Office) and the Montana Department of State Lands (Department), their agents, employees, or contractors, the right to enter upon the above-described property:

- to DETERMINE THE EXISTENCE OF adverse effects of past coal hard rock mining practices and to determine the feasibility of restoration, reclamation, abatement, control, or prevention of such adverse effects. I/We give this consent for the length of time necessary to complete the EXPLORATORY WORK subject to my/our continued ownership and use of the property.
- to RESTORE, RECLAIM, ABATE, CONTROL OR PREVENT the adverse effects of past coal hard rock mining practices and to do all things necessary or expedient to protect the public health, safety, or general welfare. I/We give this consent for the length of time as set forth in the "Work Description" necessary to complete the RECLAMATION described on the "Work Description" attached hereto subject to my/our continued ownership and use of the property.

Entry and exploratory or reclamation and abatement work, if any, performed by the Office and/or the Department, their agents, employees, or contractors, is pursuant to the authority granted in Title IV of the Surface Mining Control and Reclamation Act of 1977, 30 USC 1231 et seq. and Section 82-4-239 MCA (Montana Code Annotated).

I/We understand that:

- there will be no lien placed against my/our above-described property for reclamation work and that reclamation work is to be performed at no cost to me/us. I/We represent that I/we did not consent to, participate in or exercise control over the mining operation which necessitated the reclamation work. (Land mined for coal and deed acquired before 5/2/77; land mined for hard rock minerals)
- a lien may be placed on my/our property if the reclamation work performed results in an increase in the market value of my property. The lien, if appropriate, will be determined and filed in accordance with Section 408 of the Surface Mining Control and Reclamation Act of 1977 and 30 CFR 882.13 and 30 CFR 882.14 of the rules, Section 82-4-239(5) MCA and ARM (Administrative Rules of Montana) 26.4.1242. (Land mined for coal and deed acquired after 5/2/77)

In giving my/our consent to this entry, I/we do not waive any rights conferred upon me/us by virtue of the language contained in Title IV of the Surface Mining Control and Reclamation Act of 1977, 30 USC 1231, et seq. or Section 82-4-239 MCA.

Dated this 4th day of May, 1990.

Russell E. Zonta, Mayor, Town of Belt
Owner of Record, Owner of Record

CONSENT FOR RIGHT OF ENTRY/RECLAMATION

I/We, RICHARD BALLATORE, the Owner(s), Claimant(s), Lessee(s), Rentor(s) of record of the following described property:

All holdings in SW1/4, SE1/4, Section 26, T19N, R6E Montana Meridian including specifically Lot 17 of Castner's Fourth Addition to the town of Belt.

do hereby grant to the Office of Surface Mining Reclamation and Enforcement, U.S. Department of the Interior (Office) and the Montana Department of State Lands (Department), their agents, employees, or contractors, the right to enter upon the above-described property to DETERMINE THE EXISTENCE OF AND TO RESTORE, RECLAIM, ABATE, CONTROL OR PREVENT the adverse effects of past coal hard rock mining practices and to do all things necessary or expedient to protect the public health, safety, or general welfare. I/We give this consent for the length of time as set forth in the "Work Description" necessary to complete the RECLAMATION described on the "Work Description" attached hereto subject to my/our continued ownership and use of the property.

Entry and exploratory or reclamation and abatement work, if any, performed by the Office and/or the Department, their agents, employees, or contractors, is pursuant to the authority granted in Title IV of the Surface Mining Control and Reclamation Act of 1977, 30 USC 1231 et seq. and Section 82-4-239 MCA (Montana Code Annotated).

I/We understand that:

- there will be no lien placed against my/our above-described property for reclamation work and that reclamation work is to be performed at no cost to me/us. I/We represent that I/we did not consent to, participate in or exercise control over the mining operation which necessitated the reclamation work. (Land mined for coal and deed acquired before 5/2/77; land mined for hard rock minerals)
- a lien may be placed on my/our property if the reclamation work performed results in an increase in the market value of my property. The lien, if appropriate, will be determined and filed in accordance with Section 408 of the Surface Mining Control and Reclamation Act of 1977 and 30 CFR 882.13 and 30 CFR 882.14 of the rules, Section 82-4-239(5) MCA and ARM (Administrative Rules of Montana) 26.4.1242. (Land mined for coal and deed acquired after 5/2/77)

In giving my/our consent to this entry, I/we do not waive any rights conferred upon me/us by virtue of the language contained in Title IV of the Surface Mining Control and Reclamation Act of 1977, 30 USC 1231, et seq. or Section 82-4-239 MCA.

Dated this 27 day of August, 1990.

Richard Ballatore
Owner of Record

Owner of Record

CONSENT FOR RIGHT OF ENTRY/RECLAMATION

I/We, MAYME BALLATORE, the Owner(s), Claimant(s), Lessee(s), Rentor(s) of record of the following described property:

All holdings in SW1/4, SE1/4, Section 26, T19N, R6E, Montana Meridian including specifically Lots 18 through 20 of Castner's Fourth Addition to the town of Belt and a piece of property immediately NW of Lot 17 bounded by the BN Railroad to the NE, the center section line to the NW, Anaconda Road to the SW and Lot 17 to the SE. do hereby grant to the Office of Surface Mining Reclamation and Enforcement, U.S. Department of the Interior (Office) and the Montana Department of State Lands (Department), their agents, employees, or contractors, the right to enter upon the above-described property to DETERMINE THE EXISTENCE OF AND TO RESTORE, RECLAIM, ABATE, CONTROL OR PREVENT the adverse effects of past coal hard rock mining practices and to do all things necessary or expedient to protect the public health, safety, or general welfare. I/We give this consent for the length of time as set forth in the "Work Description" necessary to complete the RECLAMATION described on the "Work Description" attached hereto subject to my/our continued ownership and use of the property.

Entry and exploratory or reclamation and abatement work, if any, performed by the Office and/or the Department, their agents, employees, or contractors, is pursuant to the authority granted in Title IV of the Surface Mining Control and Reclamation Act of 1977, 30 USC 1231 et seq. and Section 82-4-239 MCA (Montana Code Annotated).

I/We understand that:

- there will be no lien placed against my/our above-described property for reclamation work and that reclamation work is to be performed at no cost to me/us. I/We represent that I/we did not consent to, participate in or exercise control over the mining operation which necessitated the reclamation work. (Land mined for coal and deed acquired before 5/2/77; land mined for hard rock minerals)
- a lien may be placed on my/our property if the reclamation work performed results in an increase in the market value of my property. The lien, if appropriate, will be determined and filed in accordance with Section 408 of the Surface Mining Control and Reclamation Act of 1977 and 30 CFR 882.13 and 30 CFR 882.14 of the rules, Section 82-4-239(5) MCA and ARM (Administrative Rules of Montana) 26.4.1242. (Land mined for coal and deed acquired after 5/2/77)

In giving my/our consent to this entry, I/we do not waive any rights conferred upon me/us by virtue of the language contained in Title IV of the Surface Mining Control and Reclamation Act of 1977, 30 USC 1231, et seq. or Section 82-4-239 MCA.

Dated this 27 day of August, 1990.

Mayme E. Ballatore
Owner of Record

Owner of Record

CONSENT FOR RIGHT OF ENTRY/RECLAMATION

I/We, MRS. BEATRICE MacLEOD, the Owner(s), Claimant(s), Lessee(s), Rentor(s) of record of the following described property:

Lot E on the Cascade County Assesors Sec 26, T19N, R6E Plat, located in the NE1/4, SW1/4 and NW1/4, SE1/4, Sec 26, T19N, R6E on the USGS Belt, Montana 7.5 minute topographic quadrangle

do hereby grant to the Office of Surface Mining Reclamation and Enforcement, U.S. Department of the Interior (Office) and the Montana Department of State Lands (Department), their agents, employees, or contractors, the right to enter upon the above-described property to DETERMINE THE EXISTENCE OF AND TO RESTORE, RECLAIM, ABATE, CONTROL OR PREVENT the adverse effects of past coal hard rock mining practices and to do all things necessary or expedient to protect the public health, safety, or general welfare. I/We give this consent for the length of time as set forth in the "Work Description" necessary to complete the RECLAMATION described on the "Work Description" attached hereto subject to my/our continued ownership and use of the property.

Entry and exploratory or reclamation and abatement work, if any, performed by the Office and/or the Department, their agents, employees, or contractors, is pursuant to the authority granted in Title IV of the Surface Mining Control and Reclamation Act of 1977, 30 USC 1231 et seq. and Section 82-4-239 MCA (Montana Code Annotated).

I/We understand that:

- there will be no lien placed against my/our above-described property for reclamation work and that reclamation work is to be performed at no cost to me/us. I/We represent that I/we did not consent to, participate in or exercise control over the mining operation which necessitated the reclamation work. (Land mined for coal and deed acquired before 5/2/77; land mined for hard rock minerals)
- a lien may be placed on my/our property if the reclamation work performed results in an increase in the market value of my property. The lien, if appropriate, will be determined and filed in accordance with Section 408 of the Surface Mining Control and Reclamation Act of 1977 and 30 CFR 882.13 and 30 CFR 882.14 of the rules, Section 82-4-239(5) MCA and ARM (Administrative Rules of Montana) 26.4.1242. (Land mined for coal and deed acquired after 5/2/77)

In giving my/our consent to this entry, I/we do not waive any rights conferred upon me/us by virtue of the language contained in Title IV of the Surface Mining Control and Reclamation Act of 1977, 30 USC 1231, et seq. or Section 82-4-239 MCA.

Dated this 23 day of August, 1990.

Beatrice MacLeod
Owner of Record

Joseph L. Macpherson
Owner of Record

CONSENT FOR RIGHT OF ENTRY/RECLAMATION

I/We, GEORGE DRGA, the Owner(s) of record of the following described property:

NE1/4 of SW1/4 and SE1/4 NW1/4, Sec 26, T19N, R6E; East of Anaconda Road and West of BN railroad tracks on the 7.5 minute U.S.G.S. Belt, Montana topographic quadrangle.

The area marked in green on the map
do hereby grant to the Office of Surface Mining Reclamation and Enforcement, U.S. Department of the Interior (Office) and the Montana Department of State Lands (Department), their agents, employees, or contractors, the right to enter upon the above-described property:

- to DETERMINE THE EXISTENCE OF adverse effects of past coal hard rock mining practices and to determine the feasibility of restoration, reclamation, abatement, control, or prevention of such adverse effects. I/We give this consent for the length of time necessary to complete the EXPLORATORY WORK subject to my/our continued ownership and use of the property.
- to RESTORE, RECLAIM, ABATE, CONTROL OR PREVENT the adverse effects of past coal hard rock mining practices and to do all things necessary or expedient to protect the public health, safety, or general welfare. I/We give this consent for the length of time as set forth in the "Work Description" necessary to complete the RECLAMATION described on the "Work Description" attached hereto subject to my/our continued ownership and use of the property.

Entry and exploratory or reclamation and abatement work, if any, performed by the Office and/or the Department, their agents, employees, or contractors, is pursuant to the authority granted in Title IV of the Surface Mining Control and Reclamation Act of 1977, 30 USC 1231 et seq. and Section 82-4-239 MCA (Montana Code Annotated).

I/We understand that:

- there will be no lien placed against my/our above-described property for reclamation work and that reclamation work is to be performed at no cost to me/us. I/We represent that I/we did not consent to, participate in or exercise control over the mining operation which necessitated the reclamation work. (Land mined for coal and deed acquired before 5/2/77; land mined for hard rock minerals)
- a lien may be placed on my/our property if the reclamation work performed results in an increase in the market value of my property. The lien, if appropriate, will be determined and filed in accordance with Section 408 of the Surface Mining Control and Reclamation Act of 1977 and 30 CFR 882.13 and 30 CFR 882.14 of the rules, Section 82-4-239(5) MCA and ARM (Administrative Rules of Montana) 26.4.1242. (Land mined for coal and deed acquired after 5/2/77)

In giving my/our consent to this entry, I/we do not waive any rights conferred upon me/us by virtue of the language contained in Title IV of the Surface Mining Control and Reclamation Act of 1977, 30 USC 1231, et seq. or Section 82-4-239 MCA.

Dated this 2 day of June, 1990

Owner of Record

George Drga
Owner of Record

CONSENT FOR RIGHT OF ENTRY/RECLAMATION

I/We, MR. AND MRS. KENNETH MARTIN, the Owner(s) of record of the following described property:

SW1/4 of SE 1/4, Sec 26, T19N, R6E on the Belt, Montana 7.5 Minute USGS Topographic Quadrangle

do hereby grant to the Office of Surface Mining Reclamation and Enforcement, U.S. Department of the Interior (Office) and the Montana Department of State Lands (Department), their agents, employees, or contractors, the right to enter upon the above-described property:

- to DETERMINE THE EXISTENCE OF adverse effects of past coal hard rock mining practices and to determine the feasibility of restoration, reclamation, abatement, control, or prevention of such adverse effects. I/We give this consent for the length of time necessary to complete the EXPLORATORY WORK subject to my/our continued ownership and use of the property.
- to RESTORE, RECLAIM, ABATE, CONTROL OR PREVENT the adverse effects of past coal hard rock mining practices and to do all things necessary or expedient to protect the public health, safety, or general welfare. I/We give this consent for the length of time as set forth in the "Work Description" necessary to complete the RECLAMATION described on the "Work Description" attached hereto subject to my/our continued ownership and use of the property.

Entry and exploratory or reclamation and abatement work, if any, performed by the Office and/or the Department, their agents, employees, or contractors, is pursuant to the authority granted in Title IV of the Surface Mining Control and Reclamation Act of 1977, 30 USC 1231 et seq. and Section 82-4-239 MCA (Montana Code Annotated).

I/We understand that:

- there will be no lien placed against my/our above-described property for reclamation work and that reclamation work is to be performed at no cost to me/us. I/We represent that I/we did not consent to, participate in or exercise control over the mining operation which necessitated the reclamation work. (Land mined for coal and deed acquired before 5/2/77; land mined for hard rock minerals)
- a lien may be placed on my/our property if the reclamation work performed results in an increase in the market value of my property. The lien, if appropriate, will be determined and filed in accordance with Section 408 of the Surface Mining Control and Reclamation Act of 1977 and 30 CFR 882.13 and 30 CFR 882.14 of the rules, Section 82-4-239(5) MCA and ARM (Administrative Rules of Montana) 26.4.1242. (Land mined for coal and deed acquired after 5/2/77)

In giving my/our consent to this entry, I/we do not waive any rights conferred upon me/us by virtue of the language contained in Title IV of the Surface Mining Control and Reclamation Act of 1977, 30 USC 1231, et seq. or Section 82-4-239 MCA.

Dated this 5th day of July, 1990.

Marlene Cinker
Owner of Record

Owner of Record

AKA
Lilly Marlene Martin

CONSENT FOR RIGHT OF ENTRY/RECLAMATION

I/We, MRS. BETTY M. VOYTOSKI, the Owner(s), Claimant(s), Lessee(s), Rentor(s) of record of the following described property:

Lots 25 and 25A of Castner's Fourth Addition to the town of Belt, Montana, located in the SW1/4, SE1/4, Sec 26, T19N, R6E on the Belt 7.5 Minute USGS topographic quadrangle

do hereby grant to the Office of Surface Mining Reclamation and Enforcement, U.S. Department of the Interior (Office) and the Montana Department of State Lands (Department), their agents, employees, or contractors, the right to enter upon the above-described property to DETERMINE THE EXISTENCE OF AND TO RESTORE, RECLAIM, ABATE, CONTROL OR PREVENT the adverse effects of past coal hard rock mining practices and to do all things necessary or expedient to protect the public health, safety, or general welfare. I/We give this consent for the length of time as set forth in the "Work Description" necessary to complete the RECLAMATION described on the "Work Description" attached hereto subject to my/our continued ownership and use of the property.

Entry and exploratory or reclamation and abatement work, if any, performed by the Office and/or the Department, their agents, employees, or contractors, is pursuant to the authority granted in Title IV of the Surface Mining Control and Reclamation Act of 1977, 30 USC 1231 et seq. and Section 82-4-239 MCA (Montana Code Annotated).

I/We understand that:

- there will be no lien placed against my/our above-described property for reclamation work and that reclamation work is to be performed at no cost to me/us. I/We represent that I/we did not consent to, participate in or exercise control over the mining operation which necessitated the reclamation work. (Land mined for coal and deed acquired before 5/2/77; land mined for hard rock minerals)
- a lien may be placed on my/our property if the reclamation work performed results in an increase in the market value of my property. The lien, if appropriate, will be determined and filed in accordance with Section 408 of the Surface Mining Control and Reclamation Act of 1977 and 30 CFR 882.13 and 30 CFR 882.14 of the rules, Section 82-4-239(5) MCA and ARM (Administrative Rules of Montana) 26.4.1242. (Land mined for coal and deed acquired after 5/2/77)

In giving my/our consent to this entry, I/we do not waive any rights conferred upon me/us by virtue of the language contained in Title IV of the Surface Mining Control and Reclamation Act of 1977, 30 USC 1231, et seq. or Section 82-4-239 MCA.

Dated this 20 day of August, 19 90.

Betty M. Voytoski
Owner of Record

Owner of Record

CONSENT FOR RIGHT OF ENTRY/RECLAMATION

I/We, MR. AND MRS. GEORGE STANTON
_____, the Owner(s), Claimant(s), Lessee(s), Rentor(s)
of record of the following described property:

Lots 24A and 25A of Castner's Fourth Addition to the town of Belt, located in the SW1/4, SE1/4, Sec 26, T19N, R6E on the USGS Belt, Montana 7.5 minute topographic quadrangle

do hereby grant to the Office of Surface Mining Reclamation and Enforcement, U.S. Department of the Interior (Office) and the Montana Department of State Lands (Department), their agents, employees, or contractors, the right to enter upon the above-described property to DETERMINE THE EXISTENCE OF AND TO RESTORE, RECLAIM, ABATE, CONTROL OR PREVENT the adverse effects of past coal hard rock mining practices and to do all things necessary or expedient to protect the public health, safety, or general welfare. I/We give this consent for the length of time as set forth in the "Work Description" necessary to complete the RECLAMATION described on the "Work Description" attached hereto subject to my/our continued ownership and use of the property.

Entry and exploratory or reclamation and abatement work, if any, performed by the Office and/or the Department, their agents, employees, or contractors, is pursuant to the authority granted in Title IV of the Surface Mining Control and Reclamation Act of 1977, 30 USC 1231 et seq. and Section 82-4-239 MCA (Montana Code Annotated).

I/We understand that:

- there will be no lien placed against my/our above-described property for reclamation work and that reclamation work is to be performed at no cost to me/us. I/We represent that I/we did not consent to, participate in or exercise control over the mining operation which necessitated the reclamation work. (Land mined for coal and deed acquired before 5/2/77; land mined for hard rock minerals)
- a lien may be placed on my/our property if the reclamation work performed results in an increase in the market value of my property. The lien, if appropriate, will be determined and filed in accordance with Section 408 of the Surface Mining Control and Reclamation Act of 1977 and 30 CFR 882.13 and 30 CFR 882.14 of the rules, Section 82-4-239(5) MCA and ARM (Administrative Rules of Montana) 26.4.1242. (Land mined for coal and deed acquired after 5/2/77)

In giving my/our consent to this entry, I/we do not waive any rights conferred upon me/us by virtue of the language contained in Title IV of the Surface Mining Control and Reclamation Act of 1977, 30 USC 1231, et seq. or Section 82-4-239 MCA.

Dated this 23 day of Aug, 1990.

Harriet J. Stanton
Owner of Record

George H. Stanton
Owner of Record

2.7 NOTICE TO PROCEED

TO: Ed Boland Construction, Inc
4601 7th Avenue South
Great Falls, MT 59601

Date: August 28, 1990
Project: French Coulee Wetland/
Acid Mine Drainage Control
DSL AMRB 90-010

You are hereby notified to commence Work in accordance with the Agreement, dated August 15, 1990, no later than August 28, 1990, and you are to complete the Work within 60 consecutive calendar days thereafter. The date of completion of all Work is, therefore, October 20, 1990.

OWNER: DEPARTMENT OF STATE LANDS

By: Larry Marshall
LARRY MARSHALL, CHIEF
Title: Abandoned Mine Reclamation Bureau

ACCEPTANCE OF NOTICE

Receipt of the above Notice to Proceed is hereby acknowledged this 4TH day of SEPT., 1990.

ED BOLAND CONST. INC.
CONTRACTOR

By: Ed Boland
Title: G.P.

2.4 AGREEMENT

STATE OF MONTANA DEPARTMENT OF STATE LANDS

FORM OF AGREEMENT BETWEEN CONTRACTOR AND OWNER

This Agreement made on August 15, 1990, between Ed Boland Construction, Inc., hereinafter called the "Contractor", and the STATE OF MONTANA, acting by and through the Commissioner, DEPARTMENT OF STATE LANDS, hereinafter called the "Owner".

WITNESSETH, that the Contractor and the Owner for the consideration hereinafter named agree as follows:

ARTICLE 1. SCOPE OF WORK

The Contractor shall furnish all the materials and perform all of the work for the general portion of the Contract as shown on the Drawings and described in the Specifications entitled French Coulee Wetland/Acid Mine Drainage Control, DSL/AMRB 90-010, and shall do everything required by the Contract Documents.

ARTICLE 2. TIME OF COMPLETION

The work to be performed under this Contract shall be commenced on or before a date set forth by the Owner in a written "Notice to Proceed" and shall be completed within sixty (60) calendar days.

Liquidated damages are Four Hundred Dollars (\$400.00) per calendar day.

ARTICLE 3. THE CONTRACT SUM

The Owner shall pay the Contractor for the performance of the Contract, subject to additions and deductions provided, in current funds as follows:

Five Hundred ninety two thousand two hundred fifty three dollars and sixteen cents. (592,253.16)

ARTICLE 4. PROGRESS PAYMENTS

The Owner shall make payments on account of the Contract as follows: ninety (90) percent of the value, based on the Contract prices of labor and materials incorporated in the work and of materials suitably stored at the project site or at some other location agreed upon in writing, up to the last day of the month, less the aggregate of the previous payments.

ARTICLE 5. ACCEPTANCE AND FINAL PAYMENT

Final payment shall be due thirty (30) days after completion and acceptance of the work, provided the work is fully completed and the Contract is fully performed. Upon receipt of written notice that the work is ready for final inspection and acceptance, the Owner shall promptly make his inspection; and when he finds the work acceptable under the Contract and the Contract fully performed, he shall promptly issue a final certificate, over his own signature, stating the work provided for in this Contract has been completed and is acceptable by him under its terms and conditions and that the entire balance found to be due the Contractor and noted in the final certificate is due and payable.

Before issuance of a final certificate, the Contractor shall submit evidence satisfactory to the Owner that all payrolls, materials bills, and other indebtedness connected with the work have been paid. If the work has been substantially completed and the Owner certifies that full completion thereof is materially delayed through no fault of the Contractor, the Owner shall, without terminating the Contract, make payment of the balance due for the portion of the work fully completed and accepted. Payment shall be made under the terms and conditions governing final payment, except that it shall not constitute a waiver of claims.

ARTICLE 6. NO DAMAGES FOR DELAY - OTHER CONTRACTORS

It shall be the affirmative duty of each and every Contractor on the project to cooperate and coordinate the scheduling and progress of its work with that of all other Contractors. Under no circumstances shall the State of Montana be liable for any damages for delay caused by the acts or omissions of another Contractor, and each Contractor expressly consents to suit by other Contractors for each and every claim for delay by said Contractors performing work on the aforementioned project. It is further stipulated and agreed that the terms of this provision shall govern over any other Contract document as defined in Article 7, infra.

ARTICLE 7. THE CONTRACT DOCUMENTS

The Bid Documents, together with this Agreement, form the Contract; and they are as totally a part of the Contract as if hereto attached or herein repeated. The following is an enumeration of the Bid Documents:

The Invitation for Bids, Instructions to Bidders, Proposal, Bid Bond, Notice of Award, Performance Bond or Letter of Credit, Labor and Material Bond or Letter of Credit, Notice to Proceed, Work Directive Change, Change Order, Affidavit on Behalf of Contractor, General Conditions, Special Provisions, Technical Specifications, Plans and Wage Rates.

ARTICLE 8. STANDARD PREVAILING RATE OF WAGES AND PREFERENCE OF MONTANA LABOR

The Contractor and Subcontractors shall pay the standard prevailing rate of wages, including fringe benefits for health and welfare and pension contributions and travel allowance provisions in effect and applicable to the county or locality in which the work is being performed. These prevailing wage rates will be determined by the Commissioner of Labor and Industry, State of Montana in accordance with 18-2-401 and 18-2-407, Montana Code Annotated, and will be attached to the Specifications and are incorporated herein.

ARTICLE 9. VENUE

In the event of litigation concerning the Contract, venue shall be the First Judicial District in and for the County of Lewis and Clark, Montana, and the agreement shall be interpreted according to the laws of Montana.

WHEREOF the parties hereto have executed this Agreement, the day and year first above written.

CONTRACTOR:

ED BOLAND CONSTRUCTION INC
(Firm)
Ed Boland
(Signature)
ED BOLAND - PRESIDENT
(Typed/Printed Name and Title)

OWNER:

STATE OF MONTANA
DEPARTMENT OF STATE LANDS
you are
[Signature]
Commissioner
8-15-90
Date

2.3 NOTICE OF AWARD

JUL 11 1990

DEPT. OF STATE LANDS

TO: Ed Boland Construction, Inc.
4601 7th Avenue South
Great Falls, MT 59401

PROJECT DESCRIPTION: French Coulee Wetland/Acid Mine Drainage Control, Cascade County, Montana, DSL/AMRB-90-010.

The Owner has considered the Bid submitted by you for the above-described Work in response to its Advertisement for Bids dated June 10, 1990 and Information for Bidders.

You are hereby notified that your bid has been accepted for items in the amount of \$ 592,253.16.

You are required by the Information for Bidders to execute the Agreement and furnish the required Contractor's Performance Bond, Labor and Material Bond, and certificates of insurance within ten (10) calendar days from the date of this Notice to you.

If you fail to execute said Agreement and to furnish said Bonds within ten (10) days from the date of this Notice, said Owner will be entitled to consider all your rights arising out of the Owner's acceptance of your Bid as abandoned and as forfeiture of your Bid Bond. The Owner will be entitled to such other rights as may be granted by law.

You are required to return an acknowledged copy of this Notice of Award to the Owner.

Dated 5 day of July, 1990.

OWNER: DEPARTMENT OF STATE LANDS

By: Larry Marshall

LARRY MARSHALL, CHIEF

Title: Abandoned Mine Reclamation Bureau

ACCEPTANCE OF NOTICE

Receipt of the above Notice of Award is hereby acknowledged this 14 day of July, 1990.

CONTRACTOR: ED BOLAND CONSTRUCTION INC

By: Ed Boland

Title: PRESIDENT

Chen-Northern, Inc.

A member of the **HIH** group of companies

528 SMELTER AVENUE
P. O. BOX 949
GREAT FALLS, MT 59403
(406) 453-1641
FAX (406) 727-2070

TECHNICAL REPORT

RECEIVED OCT 24 1990

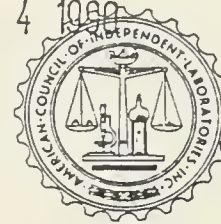

COPY

REPORT TO:

BOLAND CONSTRUCTION (2)
4601 - 7TH AVENUE SOUTH
GREAT FALLS, MT 59405

DATE: October 18, 1990
JOB NUMBER: 79-358
SHEET: 1 OF 2
INVOICE NO.: 88680

REPORT OF: Field density tests of compacted backfill material for Cells 1, 2 and 3, Belt Mine Reclamation

SAMPLE IDENTIFICATION:

Attached are the results of field density tests performed on the above-referenced project on the dates and at the locations shown. Unless otherwise noted, our personnel utilized the nuclear densameter method of testing in accordance with ASTM D2922. In accordance with our quality control procedures, occasional routine correlation tests are performed using sand cone methods in accordance with ASTM D1556.

Contractor: Boland Construction

Test Locations were selected by: Chen-Northern personnel at random locations

Minimum required in-place density: 85% of the maximum laboratory density

Maximum density as determined by: ASTM D698

Remarks:

Reviewed By:

Distribution:

TEST RESULTS:

| Test Date | Lab No. | Field Moisture Content, % | Field Dry Density, pcf | Maximum Lab Dry Density, pcf | Percent Maximum Obtained |
|---|---------|---------------------------|------------------------|------------------------------|--------------------------|
| 10/10/90 | 45739 | 11.8 | 106.9 | 108.5 (a) | 98.5 |
| Location: Cell #1, Sta. 2+95, 22' toward Cell #1 from railroad track, at subgrade. | | | | | |
| 10/10/90 | 45740 | 10.8 | 113.9 | 119.0 (b) | 95.7 |
| Location: Cell #2, Sta. 6+03, 19' toward Cell #2 from railroad track, at subgrade. | | | | | |
| 10/10/90 | 45741 | 15.7 | 97.4 | 100.0 (b) | 97.4 |
| Location: Cell #3, Sta. 13+00, 33' toward Cell #3 from railroad track, at subgrade. | | | | | |

- (a) Maximum Density Curve - Performed by Braun Engineering
- (b) Maximum Density Curve - Performed by Braun Engineering
- (c) Maximum Density Curve - Lab No. 44981

October 22, 1990

Mr. Edward Spotts
Schafer & Associates
P. O. Box 6186
Bozeman, MT 59715

Dear Ed:

I have attached copies of the soil tests we performed on the seven samples from the French Coulee Project. The samples are numbered in order of reception. The respective sample locations, as I understand, are as follows:

| <u>Sample</u> | <u>Source Location</u> |
|---------------|------------------------|
| 1 | Cell 1 - In Situ |
| 2 | Cell 2 - In Situ |
| 3 | Cell 3 - In Situ |
| 4 | Local Clay Pit |
| 5 | Lalich Alfalfa Field |
| 6 | Belidore North |
| 7 | Belidore South |

Apparently sample 5 was ultimately used for the soil-bentonite membrane. The other samples were either too clayey or contained unacceptable amounts of carbonate and/or sulfate.

The data sheets are self-explanatory except for the first sheet on samples 1, 2, and 3. These first sheets are comparisons of the respective French Coulee samples with similar samples previously tested by Wyo-Ben.

Mr. Edward Spotts
October 22, 1990
Page 2

If you need clarification of the data or additional information, please let me know. Thank you for the business, and if you have a current or future project in which you feel our bentonite products may be applicable, please let me know.

Best regards,



Ronald J. Wells
Sales Representative

RJW/jdm

rjwspotts@ed



#1

0905-803 MDD MC Perm T/PC rate
 ranch Cooley
 1.8/34.6/42.8/20.8 105 18 140^{-7} 200 Plus 4-9%
 contaminants
 4.2 lbs/ft³
 2.8 lbs/ft²

eta ca.
 0/34.8/41.2/24.0 105.8 18.1 33×10^{-8} -10 xtra 2%
 +

il Services Ky.
 0/32/44.4/23.6 105 17 5.6×10^{-8} -10 3

river Mass
 0/31.6/55.6/12.8 110 13 3.9×10^{-7} 200 8
 4.37×10^{-6} -10 8

Est. Gate Mt.
 0/36/52/12 110 12 5×10^{-8} 200 8.5

QUALITATIVE SOILS ANALYSIS

DATE 9-5-90

JOB: French road

ENGINEER/CONTRACTOR: Boland Const.

SOIL SAMPLE I.D. 0905903

MOISTURE CONTENT (% dry weight, as received)

Tare wt: (#6) 77.81

Wet Gross: 237.29

Wet Net: 159.48

Dry Gross: 220.46

Dry Net: 142.65

MC wt: 16.83 = 11.8 %

PARTICLE SIZE ANALYSIS

Gravel (+10) Test

Tare wt: (#6) 77.81

Wet Gross Wt. Whole Sample 237.29

Wet Net Wt. Whole Sample 159.48

Wet Net Wt. Whole Sample $\times \left(\frac{100 - MC\%}{100} \right) =$ Dry Net Wt. Whole Sample 140.66

Tare Wt: (#6) 77.81

Dry Gross Wt. +10 Sample 80.10

Dry Net Wt. +10 Sample 2.59

Dry Net Wt. +10 Sample \div Dry Net Wt. Whole Sample = +10 1.8 %

Hydrometer Test

| Reading (gms) | Temp. (°F) | Corr. (0.2g/°F) | Corr. (Reading (gm)) | Time off |
|--------------------|----------------|-----------------|----------------------|---------------|
| 40 sec. <u>31</u> | <u>75</u> | <u>1.4</u> | <u>32.4</u> | |
| 120 min. <u>9</u> | <u>76</u> | <u>1.6</u> | <u>10.6</u> | <u>3:22</u> |
| Wt(gms) | +10 Mesh | -10 Mesh Sand | Silt | Clay |
| %(Screened sample) | | <u>17.6</u> | <u>21.8</u> | <u>10.6</u> |
| %(Whole Sample) | <u>1.8</u> | <u>35.2</u> % | <u>43.6</u> % | <u>21.2</u> % |
| | <u>7.942</u> % | <u>34.6</u> % | <u>42.8</u> % | <u>20.8</u> % |

Apparent Organic Material (Roots, etc.): 0

Mica (type, relative amount): 2-4

Textural Soil Description: loam

pH _____

CO₃: 01234

SO₄: 01234

% VOIDS

Proctor Results (from _____)

X=MDD _____ lb./ft³ @ _____ % MC.

Y=Dry wt. of test sample _____ gm.

Z=Volume of test sample _____ cc

V_s=Volume of Solids in X

V=Volume of 1 ft.³ = 28317 cc.

$\frac{X}{Y} Z = V_s$ (_____) =

$\frac{V - V_s}{V} = \% \text{ Voids}$ $\frac{28317 - \text{_____}}{28317} =$

swell
22 compared to 26

**LABORATORY DATA SHEET
COMPACTION PERMEABILITY TEST**

Test Cell # 3

Test Date: 9-10-90

Job: French Cooley Grt. Falls MT.

Contractor: Boland Const.

Soil Sample I.D.: 0905903 (#1)

Test # 1 of Bentonite: 200 Xtra 1#/r 507 Amt. 4 % = 4.2 lb./cu.ft.
PLUS SA 1771

Soils Data

Proctors: Max Dry Density 125 lb./cu.ft.³ Optimum Moisture Content 18 %

Proctor Maximum Dry Density Adjustment For Added Bentonite

| | | | | | | | | | | |
|--|-------------------------|-----|-----|------------|-----|-----|-----|-----|-----|-----|
| Bentonite % | 1 | 2 | 3 | <u>4</u> | 5 | 6 | 7 | 8 | 9 | 10 |
| Proctor M.D. Density Decrease (lb./cu.ft.) | 1 | 1.4 | 1.8 | <u>2.2</u> | 2.7 | 3.1 | 3.6 | 4.0 | 4.4 | 4.8 |
| Net Maximum Dry Density | <u>102.8</u> lb./cu.ft. | | | | | | | | | |

Particle Size Analysis +10 1.8 %; -10 Sand 34.6 %; Silt 42.8 %; Clay 20.8 %

Calcium: CaCO₃ (Acid Reaction) 0 1 2 3 CaSO₄ (BaSO₄ Reaction) 1 2 3

pH (Sat. Paste by Strip): - Moisture Content (As Received): 11.8 %

Project Specifications

Permeability: K = 1 X 10⁻⁷ cm/sec, or, Hydraulic Conductivity: @ Head

Compaction: 90 % (Standard/Modified) Membrane Thickness: "

Compaction Moisture Content 20 % = 2 % over Optimum

Test Parameters

Constants: 6" Cell Diameter = 15.24; Cross Sectional Area = 182.41 cm²
2" Membrane Volume = 0.03272 ft³

Membrane Composition

Total Dry Wt: Vol. 0.3272 ft³ x Net MDD 102.8 16/ft³ x 453.6 gm/lb = 1525.7 gm
 Compaction Spec. Total Dry Wt: Compact Spec. 90 % x Total Dry Wt 1525.7 gm = 1373.2 gm
 Bentonite @ 0% MC: Comp. Spec. Dry Wt. of Memb. 1373.2 gm x Bentonite % 4 = 54.9 gm
 Bentonite @ Product MC (18.9 %): Bent. Dry Wt. 54.9 gm + (100-Bent. MC 8.9 %) = 60.3 gm
 Soil @ 0% MC: Comp. Spec. Dry Wt. of Memb. 1373.2 gm - Dry Wt. of Bent. 54.9 gm = 1318.3 gm
 Soil @ Received MC (11.8 %): Dry Soil Wt 1318.3 gm + (100 - Soil MC 11.8 %) = 1494.7 gm

Water Additions to Achieve Compaction Moisture Content (CMC%)

Bentonite: Bent. @ 0% MC 54.9 gm + (100 - CMC% 20) - Bent. @ Product MC 60.3 gm = 9.3 ml
 Soil: Soil @ 0% MC 1318.3 gm + (100 - CMC% 20) - Soil @ Received MC 1494.7 gm = 153.2 ml
 Total Water Addition: Bentonite 9.3 ml + Soil 153.2 ml = 161.5 ml + 2.5% = 165.5 ml

Test Membrane Specs.

Membrane Thickness: 7" - Mold Freeboard 13.1 cm = 4.68 cm (1.84 ")
 Membrane Volume: Membrane Thickness 1.84 " x 28.274 in² + 1728 in³/ft³ = 0.03011 ft³
 Compactive Effort: #Hammer Blows 19 x 15 ft lb/blow + Memb. Vol. 0.03011 ft³ = 946.3 ft lb/ft³
 Calculated % Compaction: Expected Memb. Vol. 0.3272 ft³ + Calculated Memb. Vol. 0.03011 ft³ x
 (100 - Specified Compaction 90 %) = 97.7 %
 (2100)
 Soil Lost (Dry Wt): gm (Tare [#]), Wet grs. , Dry grs. , MC = %
 Net Calculated Dry Membrane Wt: Total Memb. Dry Wt. gm - Soil Lost gm = gm
 Membrane Wt/ft³: Net Calc. Dry Memb. Wt. 1373.2 gm + 453.6 gm/lb + Memb. Vol. 0.03011 ft³ = 105 lb/ft³

II 2

| | MOD | MC | Perm | Type | rate |
|--|-----|-------|--------------------|-------------|---|
| 0905904 French Cooley 7/12/69.1/29.0 | 103 | 17.21 | 1×10^{-7} | 200 plus | 4.2% contaminates 4.12 lbs/ft ³ 2.8 |

1 tower ca.

| | | | | | |
|-----------------|-----|------|----------------------|---------------|---|
| 0/13.6/668/19.6 | 107 | 20.5 | 6.2×10^{-8} | 10 extra + | 6 |
|-----------------|-----|------|----------------------|---------------|---|

catello

| | | | | | |
|----------------|-------|------|--|------------|------------|
| 0/20/63.6/16.4 | 105.5 | 16.8 | | -10 200 | 3.3 2.2 |
|----------------|-------|------|--|------------|------------|

shland mass

| | | | | | |
|----------------|-----|----|----------------------|----------------|---|
| 0/10.4/76/13.6 | 100 | 23 | 4.5×10^{-6} | -10 extra + | 8 |
|----------------|-----|----|----------------------|----------------|---|

SU

| | | | | | |
|-----------|-----|------|----------------------|-----|----|
| 0/4/74/22 | 102 | 19.5 | 6.3×10^{-8} | 200 | 2% |
|-----------|-----|------|----------------------|-----|----|

QUALITATIVE SOILS ANALYSIS

DATE 9-5-90

JOB: French covey

ENGINEER/CONTRACTOR: Boland const.

SOIL SAMPLE I.D. 0905904

MOISTURE CONTENT (% dry weight, as received)

Tare wt: (# 5') 84.92

Wet Gross: 255.66

Wet Net: 170.74

Dry Gross: 235.12

Dry Net: 150.20

MC wt: 20.54 = 13.7 %

PARTICLE SIZE ANALYSIS

Gravel (+10) Test

Tare wt: (# 5') 84.92

Wet Gross Wt. Whole Sample 255.66

Wet Net Wt. Whole Sample 170.74

Wet Net Wt. Whole Sample $\times \left(\frac{100 - MC\%}{100} \right) =$ Dry Net Wt. Whole Sample 147.35

Tare Wt: (# 5') 84.92

Dry Gross Wt. +10 Sample 85.93 Dry Net Wt. +10 Sample 1.01

Dry Net Wt. +10 Sample \div Dry Net Wt. Whole Sample = +10 .7 %

Hydrometer Test

| | Reading (gms) | Temp. (°F) | Corr. (0.2g/°F) | Corr. (Reading (gm)) | Time off | |
|--------------------|---------------|------------|-----------------|----------------------|----------|------|
| 40 sec. | 48 | 75 | 1.4 | 49.4 | | |
| 120 min. | 13 | 76 | 1.6 | 14.6 | | |
| Wt(gms) | | +10 Mesh | -10 Mesh Sand | Silt | Clay | 3:24 |
| %(Screened sample) | | | 1.2 % | 69.6 % | 29.2 % | |
| %(Whole Sample) | | .7 % | 1.9 % | 69.1 % | 29.0 % | |

Apparent Organic Material (Roots, etc.): 0

Mica (type, relative amount): 2-4

Textural Soil Description: silty clay 100m

pH: _____

CO₃: 01234

SO₄: 01234

% VOIDS

Proctor Results (from _____)

X=MDD _____ lb./ft³ @ _____ % MC.

Y=Dry wt. of test sample _____ gm.

Z=Volume of test sample _____ cc

V_s=Volume of Solids in X

V=Volume of 1 ft.³ = 28317 cc.

$$\frac{X}{Y} Z = V_s \quad (\quad) =$$

$$\frac{V - V_s}{V} = \% \text{ Voids} \quad \frac{28317 - \quad}{28317} =$$

Swell
17 compared to 26

**LABORATORY DATA SHEET
COMPACTION PERMEABILITY TEST**

Test Cell # 4

Test Date: 9-10-90

Job: French Conley Cart Falls MT

Contractor: Boland Const.

Soil Sample I.D.: 090590 4 (# 2)

Test # 2 of _____ Bentonite: 200 x 100 + 1 1/2 (171) 500 Amt. 4 % = 4.32 lb./cu.ft.

Soils Data

Proctors: Max Dry Density 108 lb./cu.ft.³ Optimum Moisture Content 18 %

Proctor Maximum Dry Density Adjustment For Added Bentonite

| | | | | | | | | | | |
|--|---|-----|-----|------------|-----|-----|-----|-----|-----|-----|
| Bentonite % | 1 | 2 | 3 | <u>4</u> | 5 | 6 | 7 | 8 | 9 | 10 |
| Proctor M.D. Density Decrease (lb./cu.ft.) | 1 | 1.4 | 1.8 | <u>2.2</u> | 2.7 | 3.1 | 3.6 | 4.0 | 4.4 | 4.8 |

Net Maximum Dry Density 105.8 lb./cu.ft.

Particle Size Analysis +10 7 %; -10 Sand 1.2 %; Silt 69.1 %; Clay 27.0 %

Calcium: CaCO₃ (Acid Reaction) 0 1 2 3 CaSO₄ (BaSO₄ Reaction) 0 1 2 3

pH (Sat. Paste by Strip): _____ Moisture Content (As Received): 3.3 %

Project Specifications

Permeability: K = 1 X 10⁻⁷ cm/sec or, Hydraulic Conductivity: _____ @ _____ Head

Compaction: 90 % (Standard/Modified) Membrane Thickness: _____

Compaction Moisture Content 19 % = 2 % over Optimum

Test Parameters

Constants: 6" Cell Diameter = 15.24; Cross Sectional Area = 182.41 cm²

2" Membrane Volume = 0.03272 ft³

Membrane Composition

Total Dry Wt: Vol. 0.03272 ft³ x Net MDD 105.8 16/ft³ x 453.6 gm/lb = 1570.3 gm

Compaction Spec. Total Dry Wt: Compact Spec. 90 % x Total Dry Wt 1570.3 gm = 1413.2 gm

Bentonite @ 0% MC: Comp. Spec. Dry Wt. of Memb. 1413.2 gm x Bentonite % 4 = 56.5 gm

Bentonite @ Product MC (19 %): Bent. Dry Wt. 56.5 gm + (100 - Bent. MC 19 %) = 62.1 gm

Soil @ 0% MC: Comp. Spec. Dry Wt. of Memb. 1413.2 gm - Dry Wt. of Bent. 56.5 gm = 1356.7 gm

Soil @ Received MC (3.3 %): Dry Soil Wt 1356.7 gm + (100 - Soil MC 3.3 %) = 1403.0 gm

Water Additions to Achieve Compaction Moisture Content (CMC%)

Bentonite: Bent. @ 0% MC 56.5 gm + (100 - CMC% 19) - Bent. @ Product MC 62.1 gm = 7.7 ml

Soil: Soil @ 0% MC 1356.7 gm + (100 - CMC% 19) - Soil @ Received MC 1403.0 gm = 271.9 ml

Total Water Addition: Bentonite 7.7 ml + Soil 271.9 ml = 279.6 ml + 2.5% = 286.6 ml

Test Membrane Specs.

Membrane Thickness: 7" - Mold Freeboard 12.9 cm = 4.88 cm (1.92 ")

Membrane Volume: Membrane Thickness 1.92 " x 28.274 in² + 1728 in³/ft³ = 0.03142 ft³

Compactive Effort: #Hammer Blows 14 x 15 ft lb/blow + Memb. Vol. 0.03142 ft³ = 8593.3 ft lb/ft³

Calculated % Compaction: Expected Memb. Vol. 0.03272 ft³ + Calculated Memb. Vol. 0.03142 ft³ x

$$\frac{(100 - \text{Specified Compaction } 90\%) = 93.7\%}{2100}$$

Soil Lost (Dry Wt): _____ gm (Tare [#] _____), Wet grs. _____, Dry grs. _____, MC _____ = _____ %

Net Calculated Dry Membrane Wt: Total Memb. Dry Wt. _____ gm - Soil Lost _____ gm = _____ gm

Membrane Wt/ft³: Net Calc. Dry Memb. Wt. 1413.2 gm + 453.6 gm/lb + Memb. Vol. 0.03142 ft³ = 99.2 lb/ft³

500
214.3

Test Cell # 4

21011-11/1002

| Hydration | Time | Date | Pressure |
|-----------|---------|---------|------------|
| Begin | 2:30 | 9-10-90 | 7" |
| Change 1 | 8:00 | 9-13-90 | 7" ± 2 PSI |
| Change 2 | | 9-12-90 | 1 PSI |
| Change 3 | gradual | 9-13-90 | 7" ± 3 |
| Change 4 | gradual | 9-18-90 | 5.25 PSI |
| Change 5 | | | |
| End | | | |

TESTS

$$K \text{ (cm./sec.)} = \frac{\text{Outflow (ml)} \times \text{Memb. Thickness (cm)}}{\text{Head Pressure (cm Water)} \times \text{Memb. Area (cm}^2\text{)} \times \text{Time (Secs)}}$$

| | Time | Date | Pressure | Outflow |
|--------|--|---------|------------|--|
| Test 1 | | | | |
| Begin | 8:11 | 9-17-90 | 6.54 + 3.8 | |
| End | 2:47 | | | 9.8 ml |
| K = | $\frac{9.8 \text{ ml} \times 4.88 \text{ cm}}{283.8 \text{ cm} \times 182.41 \text{ cm}^2 \times 23760 \text{ secs}}$ | | | $= 3.89 \times 10^{-8} \text{ cm/sec}$ |
| Test 2 | | | | |
| Begin | 8:32 | 9-19-90 | 6.17 + 5.3 | |
| End | 1:48 | | | 10.4 ml |
| K = | $\frac{10.4 \text{ ml} \times 4.88 \text{ cm}}{386.3 \text{ cm} \times 182.41 \text{ cm}^2 \times 15360 \text{ secs}}$ | | | $= 4.66 \times 10^{-8} \text{ cm/sec}$ |
| Test 3 | | | | |
| Begin | 8:04 | 9-21-90 | 5.82 + 5.3 | |
| End | 11:50 | | | 8.0 ml |
| K = | $\frac{8.0 \text{ ml} \times 4.88 \text{ cm}}{387.4 \text{ cm} \times 182.41 \text{ cm}^2 \times 13560 \text{ secs}}$ | | | $= 4.0 \times 10^{-8} \text{ cm/sec}$ |
| Test 4 | | | | |
| Begin | 7:59 | 9-24-90 | 5.13 + 5.3 | |
| End | 12:33 | | | 9.3 ml |
| K = | $\frac{9.3 \text{ ml} \times 4.88 \text{ cm}}{385.7 \text{ cm} \times 182.41 \text{ cm}^2 \times 16440 \text{ secs}}$ | | | $= 3.92 \times 10^{-8} \text{ cm/sec}$ |
| Test 5 | | | | |
| Begin | | | | |
| End | | | | ml |
| K = | $\frac{\text{ml} \times \text{cm}}{\text{cm} \times \text{cm}^2 \times \text{secs}}$ | | | cm/sec |

3

| 0905905 | MD | MC | Perm | TYPE | rate |
|------------------|-----|----|--------------------|------|--|
| French cooley | 108 | 18 | 1×10^{-7} | 2000 | 3% 2.5% |
| 7.9/34.3/43.8/14 | | | | | 2.63 lbs/ft ³ 1.74 lbs/ft ² |

olota ca.

| | | | | | |
|----------------|-------|------|----------------------|-----------------|----|
| 0/34.8/41.2/24 | 105.8 | 18.1 | 3.3×10^{-8} | -10 KTH PLUS | 2% |
|----------------|-------|------|----------------------|-----------------|----|

QUALITATIVE SOILS ANALYSIS

DATE 9-5-90

JOB: French clay

ENGINEER/CONTRACTOR: Boland, Const.

SOIL SAMPLE I.D. 0905905

MOISTURE CONTENT (% dry weight, as received)

Tare wt: (#17) 84.93

Wet Gross: 290.76

Wet Net: 205.83

Dry Gross: 244.63

Dry Net: 159.20

MC wt: 46.13 = 29.9 %

PARTICLE SIZE ANALYSIS

Gravel (+10) Test

Tare wt: (#17) 84.93

Wet Gross Wt. Whole Sample 290.76

Wet Net Wt. Whole Sample 205.83

Wet Net Wt. Whole Sample $\times \left(\frac{100 - MC\%}{100} \right) =$ Dry Net Wt. Whole Sample 146.25

Tare Wt: (#17) 84.93

Dry Gross Wt. +10 Sample 96.53 Dry Net Wt. +10 Sample 11.6

Dry Net Wt. +10 Sample \div Dry Net Wt. Whole Sample = +10 7.9 %

Hydrometer Test

| Reading (gms) | Temp. (°F) | Corr. (0.2g/°F) | Corr. (Reading (gm)) | Time off | |
|--------------------|------------|-----------------|----------------------|----------|-------|
| 40 sec. 30 | 75 | 1.4 | 31.4 | | |
| 120 min. 6 | 76 | 1.6 | 7.6 | | |
| Wt(gms) | +10 Mesh | -10 Mesh Sand | Silt | Clay | 31.26 |
| %(Screened sample) | | 18.6 | 23.8 | 7.6 | |
| %(Whole Sample) | 7.9 % | 37.2 % | 47.6 % | 15.2 % | |
| | | 34.3 % | 43.8 % | 14.0 % | |

Apparent Organic Material (Roots, etc.): 3-4

Mica (type, relative amount): 1-4

Textural Soil Description: loam

pH _____

CO₃: 01234

SO₄: 01234

% VOIDS

Proctor Results (from _____)

X=MDD _____ lb./ft³ @ _____ % MC.

Y=Dry wt. of test sample _____ gm.

Z=Volume of test sample _____ cc

V_s=Volume of Solids in X

V=Volume of 1 ft.³ = 28317 cc.

$$\frac{X}{Y} Z = V_s \quad (\quad) =$$

$$\frac{V - V_s}{V} = \% \text{ Voids} \quad \frac{28317 - \quad}{28317} =$$

LABORATORY DATA SHEET COMPACTION PERMEABILITY TEST

Test Cell # 1

Test Date: 9-19-90

Job: French Coadley Grt. Falls Mt.

Contractor: Boland Const.

Soil Sample I.D.: 0905915 (#3)

Test # 2 of _____ Bentonite: 200 Amt. 1 % = _____ lb./cu.ft.

Soils Data

Proctors: Max Dry Density 108 lb./cu.ft.³ Optimum Moisture Content 18 %
 Proctor Maximum Dry Density Adjustment For Added Bentonite

| | | | | | | | | | | |
|--|-----|-----|-----|-----|-----|-----|-----|-----|-----|-----|
| Bentonite % | (1) | 2 | 3 | 4 | 5 | 6 | 7 | 8 | 9 | 10 |
| Proctor M.D. Density Decrease (lb./cu.ft.) | 1 | 1.4 | 1.8 | 2.2 | 2.7 | 3.1 | 3.6 | 4.0 | 4.4 | 4.8 |

 Net Maximum Dry Density 107 lb./cu.ft.

Particle Size Analysis +10 7.9 %; -10 Sand 34.3 %; Silt 43.8 %; Clay 14.0 %
 Calcium: CaCO₃ (Acid Reaction) 0.1 2 3 CaSO₄ (BaSO₄ Reaction) 0.1 2 3
 pH (Sat. Paste by Strip): — Moisture Content (As Received): 3.3 %

Project Specifications

Permeability: K = 1 X 10⁻⁷ cm/sec or, Hydraulic Conductivity: _____ @ _____ Head
 Compaction: 90 % (Standard/Modified) Membrane Thickness: _____"
 Compaction Moisture Content 19 % = 1 % over Optimum

Test Parameters

Constants: 6" Cell Diameter = 15.24; Cross Sectional Area = 182.41 cm²
 2" Membrane Volume = 0.03272 ft³.

Membrane Composition

Total Dry Wt: Vol. 0.03272 ft³ x Net MDD 107 16/ft³ x 453.6 gm/lb = 1588.1 gm
 Compaction Spec. Total Dry Wt: Compact Spec. 90 % x Total Dry Wt 1588.1 gm = 1429.3 gm
 Bentonite @ 0% MC: Comp. Spec. Dry Wt. of Memb. 1117.7 gm x Bentonite % 1 = 143 gm
 Bentonite @ Product MC (7.9 %): Bent. Dry Wt. 14.3 gm + (100 - Bent. MC 8.9 %) = 15.7 gm
 Soil @ 0% MC: Comp. Spec. Dry Wt. of Memb. 1429.3 gm - Dry Wt. of Bent. 14.3 gm = 1415.0 gm
 Soil @ Received MC (3.3 %): Dry Soil Wt. 1415.0 gm + (100 - Soil MC 3.3 %) = 1463.3 gm

Water Additions to Achieve Compaction Moisture Content (CMC%)

Bentonite: Bent. @ 0% MC 14.3 gm + (100 - CMC% 7.9) - Bent. @ Product MC 15.7 gm = 20 ml
 Soil: Soil @ 0% MC: 1415.0 gm + (100 - CMC% 7.9) - Soil @ Received MC 1463.3 gm = 273.6 ml
 Total Water Addition: Bentonite 20 ml + Soil 273.6 ml = 293.6 ml + 2.5% = 292.8 ml

Test Membrane Specs.

Membrane Thickness: 7" - Mold Freeboard 12.5 cm = 5.29 cm (2.08 ")
 Membrane Volume: Membrane Thickness 2.08 " x 28.274 in² + 1728 in³/ft³ = 0.03403 ft³
 Compactive Effort: #Hammer Blows 19 x 15 ft lb/blow + Memb. Vol. 0.03403 ft³ = 2724.2 ft lb/ft³
 Calculated % Compaction: Expected Memb. Vol. 0.03403 ft³ + Calculated Memb. Vol. 0.03403 ft³ x
 (100 - Specified Compaction 90 %) = 86.5 %
 Soil Lost (Dry Wt): _____ gm (Tare [#] _____), Wet grs. _____, Dry grs. _____, MC _____ = _____ %
 Net Calculated Dry Membrane Wt: Total Memb. Dry Wt. _____ gm - Soil Lost _____ gm = _____ gm
 Membrane Wt/ft³: Net Calc. Dry Memb. Wt. 1429.3 gm + 453.6 gm/lb + Memb. Vol. 0.03403 ft³ = 92.6 lb/ft³

1550
27.4

Test Cell # 1

Gravel Rock

| Hydration | Time | Date | Pressure |
|-----------|-------|---------|-----------|
| Begin | 11:10 | 9-19-90 | 7" |
| Change 1 | 4:19 | 9-19-90 | 7" ± 1/2" |
| Change 2 | | | |
| Change 3 | | | |
| Change 4 | | | |
| Change 5 | | | |
| End | | | |

TESTS

$$K \text{ (cm./sec.)} = \frac{\text{Outflow (ml)} \times \text{Memb. Thickness (cm)}}{\text{Head Pressure (cm Water)} \times \text{Memb. Area (cm}^2\text{)} \times \text{Time (Secs)}}$$

| Time | Date | Pressure | Outflow |
|--|---------|-------------|---------|
| Test 1 | | | |
| Begin 8:55 | 9-21-90 | 5.71 ± 1.2 | |
| End 10:02 | | | 11 ml |
| $K = \frac{11 \text{ ml} \times 5.28 \text{ cm}}{98.9 \text{ cm} \times 182.41 \text{ cm}^2 \times 4020 \text{ secs}} = 8.01 \times 10^{-7} \text{ cm/sec}$ | | | |
| Test 2 | | | |
| Begin 7:55 | 9-24-90 | 3.68 ± 1.2 | |
| End 10:04 | | | 9.3 ml |
| $K = \frac{9.3 \text{ ml} \times 5.28 \text{ cm}}{93.7 \text{ cm} \times 182.41 \text{ cm}^2 \times 7740 \text{ secs}} = 3.71 \times 10^{-7} \text{ cm/sec}$ | | | |
| Test 3 | | | |
| Begin 8:07 | 9-25-90 | 3.21 ± 1.05 | |
| End 10:59 | | | 11.9 ml |
| $K = \frac{11.9 \text{ ml} \times 5.28 \text{ cm}}{82.0 \text{ cm} \times 182.41 \text{ cm}^2 \times 10320 \text{ secs}} = 4.07 \times 10^{-7} \text{ cm/sec}$ | | | |
| Test 4 | | | |
| Begin 8:09 | 9-26-90 | 2.85 ± 1.0 | |
| End 11:09 | | | 11.0 ml |
| $K = \frac{11.0 \text{ ml} \times 5.28 \text{ cm}}{77.6 \text{ cm} \times 182.41 \text{ cm}^2 \times 10500 \text{ secs}} = 3.80 \times 10^{-7} \text{ cm/sec}$ | | | |
| Test 5 | | | |
| Begin | | | |
| End | | | ml |
| $K = \frac{\text{ml} \times \text{cm}}{\text{cm} \times \text{cm}^2 \times \text{secs}} = \text{cm/sec}$ | | | |

1350
 Test Cell # 2

(Handwritten notes)
 General Pack
 when D.T.
 1000
 1000

| Hydration | Time | Date | Pressure |
|-----------|---------|---------|----------|
| Begin | 2:05 | 9-12-90 | 7" |
| Change 1 | 4:00 | 9-13-90 | 7"+1 |
| Change 2 | Gradual | 9-13-90 | 7"+2.5 |
| Change 3 | Gradual | 9-18-90 | 4.0 psi |
| Change 4 | | | |
| Change 5 | | | |
| End | | | |

TESTS

$$K \text{ (cm./sec.)} = \frac{\text{Outflow (ml)} \times \text{Memb. Thickness (cm)}}{\text{Head Pressure (cm Water)} \times \text{Memb. Area (cm}^2\text{)} \times \text{Time (Secs)}}$$

| Time | Date | Pressure | Outflow |
|--|---------|------------|---------|
| Test 1 | | | |
| Begin 8:09 | 9-17-90 | 6.85 + 2.5 | |
| End 3:31 | | | 4.8 ml |
| $K = \frac{4.8 \text{ ml} \times 5.18 \text{ cm}}{193.2 \text{ cm} \times 182.41 \text{ cm}^2 \times 26520 \text{ secs}} = 2.66 \times 10^{-8} \text{ cm/sec}$ | | | |
| Test 2 | | | |
| Begin 8:27 | 9-19-90 | 6.66 + 4.2 | |
| End 3:33 | | | 2.0 ml |
| $K = \frac{2.0 \text{ ml} \times 5.18 \text{ cm}}{312.2 \text{ cm} \times 182.41 \text{ cm}^2 \times 25560 \text{ secs}} = 2.5 \times 10^{-8} \text{ cm/sec}$ | | | |
| Test 3 | | | |
| Begin 8:59 | 9-20-90 | 6.45 + 4.1 | |
| End 4:00 | | | 7.3 ml |
| $K = \frac{7.3 \text{ ml} \times 5.18 \text{ cm}}{304.7 \text{ cm} \times 182.41 \text{ cm}^2 \times 25260 \text{ secs}} = 2.7 \times 10^{-8} \text{ cm/sec}$ | | | |
| Test 4 | | | |
| Begin 8:02 | 9-21-90 | 6.35 + 4.1 | |
| End 4:02 | | | 7.7 ml |
| $K = \frac{7.7 \text{ ml} \times 5.18 \text{ cm}}{304.4 \text{ cm} \times 182.41 \text{ cm}^2 \times 26800 \text{ secs}} = 2.49 \times 10^{-8} \text{ cm/sec}$ | | | |
| Test 5 | | | |
| Begin 7:56 | 9-24-90 | 6.02 + 4.1 | |
| End 3:02 | | | 6.8 ml |
| $K = \frac{6.8 \text{ ml} \times 5.18 \text{ cm}}{303.6 \text{ cm} \times 182.41 \text{ cm}^2 \times 25560 \text{ secs}} = 2.49 \times 10^{-8} \text{ cm/sec}$ | | | |

LABORATORY DATA SHEET COMPACTION PERMEABILITY TEST

Test Cell # 2

Test Date: 9-12-90

Job: French Conley GRT Falls Mt.

Contractor: Boland Const.

Soil Sample I.D.: 0905905 (#3)

Test # 1 of _____ Bentonite: 200 Amt. 2.5% = 2.7 lb./cu.ft.

Soils Data

Proctors: Max Dry Density 108 lb./cu.ft.³ Optimum Moisture Content 18 %

Proctor Maximum Dry Density Adjustment For Added Bentonite

| | | | | | | | | | | |
|--|---|-----|-----|-----|-----|-----|-----|-----|-----|-----|
| Bentonite % | 1 | 2 | 3 | 4 | 5 | 6 | 7 | 8 | 9 | 10 |
| Proctor M.D. Density Decrease (lb./cu.ft.) | 1 | 1.4 | 1.8 | 2.2 | 2.7 | 3.1 | 3.6 | 4.0 | 4.4 | 4.8 |

Net Maximum Dry Density 106.4 lb./cu.ft.

Particle Size Analysis +10 7.9 %; -10 Sand 34.3 %; Silt 43.8 %; Clay 14 %

Calcium: CaCO₃ (Acid Reaction) 0 1 2 3 CaSO₄ (BaSO₄ Reaction) 10 1 2 3

pH (Sat. Paste by Strip): _____ Moisture Content (As Received): 2.2 %

Project Specifications

Permeability: K = 1 X 10⁻⁷ cm/sec or, Hydraulic Conductivity: _____ @ _____ Head

Compaction: 90 % (Standard/Modified) Membrane Thickness: _____"

Compaction Moisture Content 19 % = 1 % over Optimum

Test Parameters

Constants: 6" Cell Diameter = 15.24; Cross Sectional Area = 182.41 cm²

2" Membrane Volume = 0.03272 ft³

4 mosh screened out

Membrane Composition

Total Dry Wt: Vol. 0.03272 ft³ x Net MDD 106.4 16/ft³ x 453.6 gm/lb = 1579.2 gm

Compaction Spec. Total Dry Wt: Compact Spec. 90 % x Total Dry Wt 1579.2 gm = 1421.3 gm

Bentonite @ 0% MC: Comp. Spec. Dry Wt. of Memb. 1421.3 gm x Bentonite % 2.5 = 35.5 gm

Bentonite @ Product MC (19 %): Bent. Dry Wt. 35.5 gm + (100 - Bent. MC 18 %) = 39.0 gm

Soil @ 0% MC: Comp. Spec. Dry Wt. of Memb. 1421.3 gm - Dry Wt. of Bent. 35.5 gm = 1385.8 gm

Soil @ Received MC (3.3 %): Dry Soil Wt 1385.8 gm + (100 - Soil MC 3.3 %) = 1433.1 gm

Water Additions to Achieve Compaction Moisture Content (CMC%)

Bentonite: Bent. @ 0% MC 35.5 gm + (100 - CMC% 19 %) - Bent. @ Product MC 39.0 gm = 4.8 ml

Soil: Soil @ 0% MC 1385.8 gm + (100 - CMC% 19 %) - Soil @ Received MC 1433.1 gm = 277.8 ml

Total Water Addition: Bentonite 4.8 ml + Soil 277.8 ml = 282.6 ml + 2.5% = 289.6 ml

Test Membrane Specs.

Membrane Thickness: 7" - Mold Freeboard 12.6 cm = 5.18 cm (2.04 ")

Membrane Volume: Membrane Thickness 2.04 " x 28.274 in² + 1728 in³/ft³ = 0.03338 ft³

Compactive Effort: #Hammer Blows 18 x 15 ft lb/blow + Memb. Vol. 0.03338 ft³ = 27068.7 ft lb/ft³

Calculated % Compaction: Expected Memb. Vol. 0.03272 ft³ + Calculated Memb. Vol. 0.03338 ft³ x (100 - Specified Compaction 90 %) = 88.2 %

Soil Lost (Dry Wt): _____ gm (Tare [#] _____), Wet grs. _____, Dry grs. _____, MC _____ = _____ %

Net Calculated Dry Membrane Wt: Total Memb. Dry Wt. _____ gm - Soil Lost _____ gm = _____ gm

Membrane Wt/ft³: Net Calc. Dry Memb. Wt. 1421.3 gm + 453.6 gm/lb + Memb. Vol. 0.03338 ft³ = 93.9 lb/ft³

PERMEABILITY CURVE

By WYO-BEN, INC. for

MADE IN USA

DRAWING PAPER NO. 1371-21
 TRACING PAPER NO. 1230-21
 SEMI-LOG. 3 CY. BY 10 DIV. / IN.

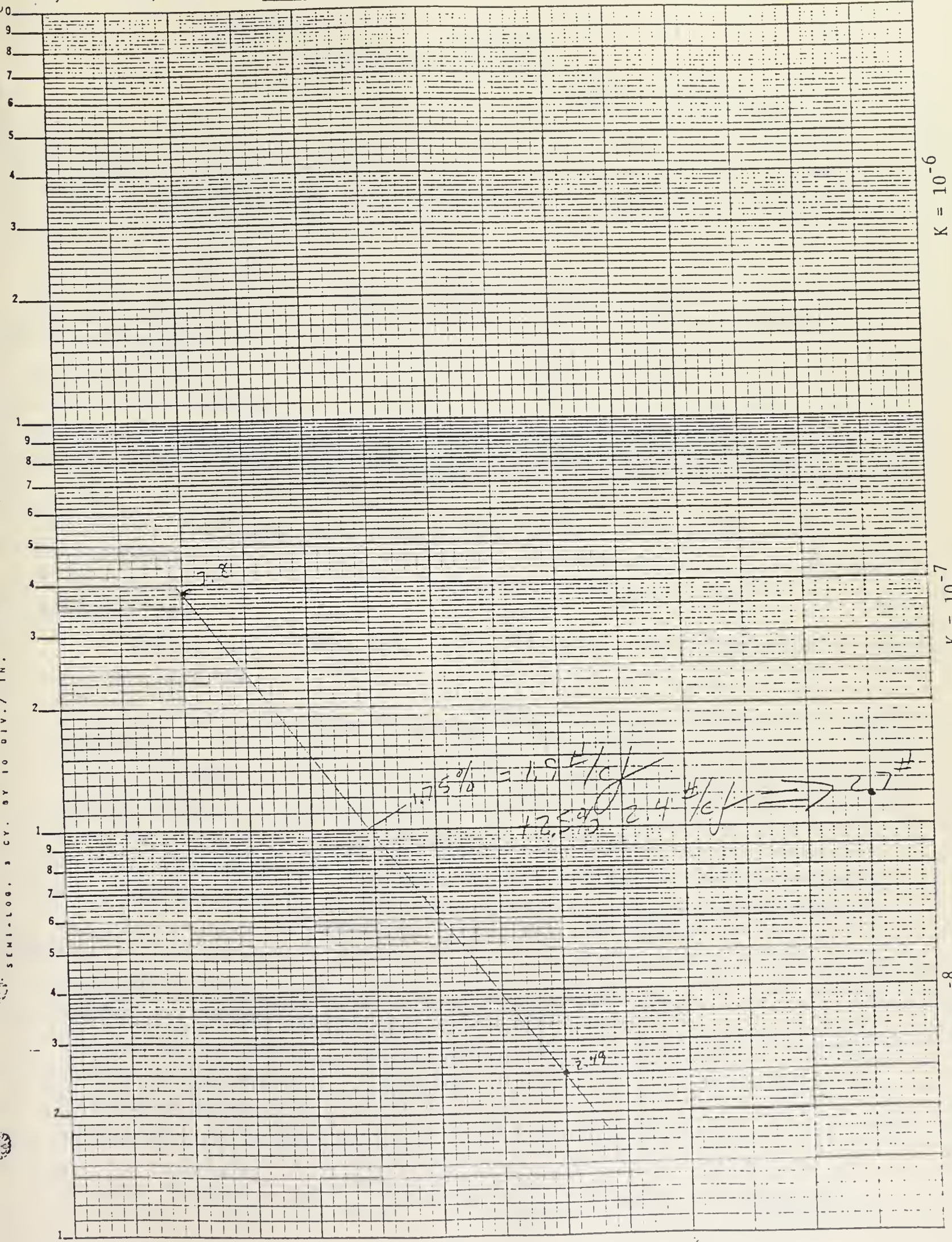

$K = 10^{-6}$

$K = 10^{-7}$

$K = 10^{-8}$

% Bentonite by Density of Soil

QUALITATIVE SOILS ANALYSIS

DATE 9-24-90

JOB French Corley

ENGINEER/CONTRACTOR: Beland Const.

SOIL SAMPLE I.D. MO21902 #4

MOISTURE CONTENT (% dry weight, as received)

Tare wt: (#5) 84.92

Wet Gross: 258.09

Wet Net: 173.17

Dry Gross: 246.16

Dry Net: 161.24

MC wt: 11.93 = 7.4 %

PARTICLE SIZE ANALYSIS

Gravel (+10) Test

Tare wt: (#5) 84.92

Wet Gross Wt. Whole Sample 258.09

Wet Net Wt. Whole Sample 173.17

Wet Net Wt. Whole Sample X $\left(\frac{100 - MC\%}{100} \right) =$ Dry Net Wt. Whole Sample 160.36

Tare Wt: (#5) 84.92

Dry Gross Wt. +10 Sample 86.57 Dry Net Wt. +10 Sample 165

Dry Net Wt. +10 Sample ÷ Dry Net Wt. Whole Sample = +10 1 %

Hydrometer Test

| Reading (gms) | Temp. (°F) | Corr. (0.2g/°F) | Corr. (Reading (gm)) | Time off |
|--------------------|--------------------|-----------------|----------------------|---------------|
| 40 sec. <u>46</u> | <u>73</u> | <u>1.0</u> | <u>47</u> | |
| 120 min. <u>32</u> | <u>71</u> | <u>1.2</u> | <u>33.2</u> | |
| Wt(gms) | +10 Mesh | -10 Mesh Sand | Silt | Clay |
| | | <u>3.0</u> | <u>13.8</u> | <u>33.2</u> |
| %(Screened sample) | | <u>6 %</u> | <u>27.6 %</u> | <u>66.4 %</u> |
| %(Whole Sample) | [<u>71.99 %</u>] | <u>5.7 %</u> | <u>27.3 %</u> | <u>65.7 %</u> |

Apparent Organic Material (Roots, etc.) 0

Mica (type, relative amount): 0

Textural Soil Description: Clay

pH _____

CO₃: 0.1234

SO₄: 0.1234

% VOIDS

Proctor Results (from _____)

X=MDD _____ lb./ft³ @ _____ % MC.

Y=Dry wt. of test sample _____ gm.

Z=Volume of test sample _____ cc

V_s=Volume of Solids in X

V=Volume of 1 ft.³ = 28317 cc.

$$\frac{X}{Y} Z = V_s \quad (\quad) =$$

$$\frac{V - V_s}{V} = \% \text{ Voids} \quad \frac{28317 - \quad}{28317} =$$

LABORATORY DATA SHEET COMPACTION PERMEABILITY TEST

Test Date: 9-24-90

Test Cell # _____

Job: Frank Cooley Grt. Falls, MT.

Contractor: Boland Const.

Soil Sample I.D.: 0921902 #4

Test # 1 of _____ Bentonite: 0 Amt. 0 % = 0 lb./cu.ft.

Soils Data

Proctors: Max Dry Density 95 lb./cu.ft.³ Optimum Moisture Content 21 %
 Proctor Maximum Dry Density Adjustment For Added Bentonite
 Bentonite %
 Proctor M.D. Density Decrease (lb./cu.ft.)

| | | | | | | | | | | | |
|--|---|---|-----|-----|-----|-----|-----|-----|-----|-----|-----|
| | 0 | 1 | 2 | 3 | 4 | 5 | 6 | 7 | 8 | 9 | 10 |
| | 0 | 1 | 1.4 | 1.8 | 2.2 | 2.7 | 3.1 | 3.6 | 4.0 | 4.4 | 4.8 |

Net Maximum Dry Density 95 lb./cu.ft.

Particle Size Analysis +10 _____ %; -10 Sand _____ %; Silt _____ %; Clay _____ %
 Calcium: CaCO₃ (Acid Reaction) 0 1 2 3 CaSO₄ (BaSO₄ Reaction) 0 1 2 3
 pH (Sat. Paste by Strip): _____ Moisture Content (As Received): 74 %

Project Specifications

Permeability: K = 1 X 10⁷ cm/sec or, Hydraulic Conductivity: _____ @ _____ Head
 Compaction: 90 % (Standard/Modified) Membrane Thickness: _____"
 Compaction Moisture Content 22 % = _____ % over Optimum

Test Parameters

Constants: 6" Cell Diameter = 15.24; Cross Sectional Area = 182.41 cm²
 2" Membrane Volume = 0.03272 ft³.

Membrane Composition

Total Dry Wt: Vol. 0.03272 ft³ x Net MDD 95 16/ft³ x 453.6 gm/lb = 1409.97 gm
 Compaction Spec. Total Dry Wt: Compact Spec. 90 % x Total Dry Wt 1409.97 gm = 1268.97 gm
 Bentonite @ 0% MC: Comp. Spec. Dry Wt. of Memb. 1268.97 gm x Bentonite % 0 = 0 gm
 Bentonite @ Product MC (_____ %): Bent. Dry Wt. 0 gm + (100 - Bent. MC _____ %) = 0 gm
 Soil @ 0% MC: Comp. Spec. Dry Wt. of Memb. 1268.97 gm - Dry Wt. of Bent. 0 gm = 1268.97 gm
 Soil @ Received MC (74 %): Dry Soil Wt. 1268.97 gm + $\frac{(100 - \text{Soil MC } 74\%) \times 1268.97}{100}$ = 1370.4 gm

Water Additions to Achieve Compaction Moisture Content (CMC%)

Bentonite: Bent. @ 0% MC 0 gm + $\frac{(100 - \text{CMC } 22) \times 0}{100}$ - Bent. @ Product MC 0 gm = 0 ml
 Soil: Soil @ 0% MC 1268.97 gm + $\frac{(100 - \text{CMC } 22) \times 1268.97}{100}$ - Soil @ Received MC 1370.4 gm = 256.5 ml
 Total Water Addition: Bentonite 0 ml + Soil 256.5 ml = 256.5 ml + 2.5% = 262.9 ml

Test Membrane Specs.

Membrane Thickness: 7" - Mold Freeboard 140 cm = _____ cm (11 7/8" + 4 1/4")
 Membrane Volume: Membrane Thickness _____" x 28.274 in² + 1728 in³/ft³ = _____ ft³
 Compactive Effort: #Hammer Blows 19 x 15 ft lb/blow + Memb. Vol. _____ ft³ = _____ ft lb/ft³
 Calculated % Compaction: Expected Memb. Vol. _____ ft³ + Calculated Memb. Vol. _____ ft³ x
 $\frac{(100 - \text{Specified Compaction } 90\%) \times 2100}{2100}$ = _____ %
 Soil Lost (Dry Wt): _____ gm (Tare [#] _____), Wet grs. _____, Dry grs. _____, MC _____ = _____ %
 Net Calculated Dry Membrane Wt: Total Memb. Dry Wt. _____ gm - Soil Lost _____ gm = _____ gm
 Membrane Wt/ft³: Net Calc. Dry Memb. Wt. _____ gm + 453.6 gm/lb + Memb. Vol. _____ ft³ = _____ lb/ft³

Soil # 2923901

#5 (Lalich alfalfa field #3)

Similar to soil #3 (#0905905)

which tested @ Sug Rate = 2.7 #/cf

use 3.0 #/cf or 1.5 #/sf/6"

Egel 200

QUALITATIVE SOILS ANALYSIS

DATE 9-25-80

JOB: French complex
 ENGINEER/CONTRACTOR: Roland Const.
 SOIL SAMPLE I.D. 1923901 #5 (Lalich alfalfa field #3)
 MOISTURE CONTENT (% dry weight, as received)

Tare wt: (#17) 84.94
 Wet Gross: 268.45 Wet Net: 183.51
 Dry Gross: 249.55 Dry Net: 164.61 MC wt: 18.9 = 11.5 %

PARTICLE SIZE ANALYSIS

Gravel (+10) Test
 Tare wt: (#17) 84.94
 Wet Gross Wt. Whole Sample 268.45 Wet Net Wt. Whole Sample 183.51
 Wet Net Wt. Whole Sample $\times \left(\frac{100 - MC\% 11.5}{100} \right) =$ Dry Net Wt. Whole Sample 162.41
 Tare Wt: (#17) 84.94
 Dry Gross Wt. +10 Sample 45.57 Dry Net Wt. +10 Sample .63
 Dry Net Wt. +10 Sample \div Dry Net Wt. Whole Sample = +10 .4 %

Hydrometer Test

| | Reading (gms) | Temp. (°F) | Corr. (0.2g/°F) | Corr. (Reading (gm)) | Time off |
|--------------------|---------------|------------|-----------------|----------------------|----------|
| 40 sec. | 34 | 76 | 1.6 | 35.6 | |
| 120 min. | 10 | 76 | 1.6 | 11.6 | 11:25 |
| | | +10 Mesh | -10 Mesh Sand | Silt | Clay |
| Wt (gms) | | | 14.4 | 24 | 11.6 |
| %(Screened sample) | | | 28.8 % | 48 % | 23.2 % |
| %(Whole Sample) | .4 | %.996 % | 28.7 % | 47.8 % | 23.1 % |

Apparent Organic Material (Roots, etc.): 4-4

Mica (type, relative amount): 0

Textural Soil Description: loam

pH _____ CO₃: 01234 SO₄: 01234

% VOIDS

Proctor Results (from _____)

X=MDD _____ lb./ft³ @ _____ % MC.

Y=Dry wt. of test sample _____ gm.

Z=Volume of test sample _____ cc

V_s=Volume of Solids in X

V=Volume of 1 ft.³ = 28317 cc.

$$\frac{X}{Y} Z = V_s \quad (\quad) =$$

$$\frac{V - V_s}{V} = \% \text{ Voids} \quad \frac{28317 - \quad}{28317} =$$

Swell!
23 compared 25

QUALITATIVE SOILS ANALYSIS

DATE 10-1-90

JOB : French clay

ENGINEER/CONTRACTOR: Billand Const.

SOIL SAMPLE I.D. 0924901 (copy)

MOISTURE CONTENT (% dry weight, as received)

Tare wt: (#6') 77.81

Wet Gross: 165.52

Wet Net: 87.71

Dry Gross: 162.17

Dry Net: 74.36

MC wt: 3.35 = 4.0 %

PARTICLE SIZE ANALYSIS

Gravel (+10) Test

Tare wt: (#6') 77.81

Wet Gross Wt. Whole Sample 165.52

Wet Net Wt. Whole Sample 87.71

Wet Net Wt. Whole Sample X $\frac{(100 - MC\%4.0)}{100}$ = Dry Net Wt. Whole Sample 84.2

Tare Wt: (#6') 77.81

Dry Gross Wt. +10 Sample 77.81 Dry Net Wt. +10 Sample 0

Dry Net Wt. +10 Sample ÷ Dry Net Wt. Whole Sample = +10 0 %

Hydrometer Test

| | Reading (gms) | Temp. (°F) | Corr. (0.2g/°F) | Corr. (Reading (gm)) | Time off |
|----------|---------------|------------|-----------------|----------------------|--------------|
| 40 sec. | <u>41</u> | <u>67</u> | <u>-1.2</u> | <u>40.8</u> | |
| 120 min. | <u>10</u> | <u>67</u> | | <u>10</u> | <u>10.38</u> |

| Wt(gms) | +10 Mesh | -10 Mesh Sand | Silt | Clay |
|--------------------|--------------|---------------|---------------|-------------|
| | | <u>9.2</u> | <u>30.8</u> | <u>10</u> |
| %(Screened sample) | | <u>18.4 %</u> | <u>61.6 %</u> | <u>20 %</u> |
| %(Whole Sample) | <u>100 %</u> | <u>18.4 %</u> | <u>61.6 %</u> | <u>20 %</u> |

Apparent Organic Material (Roots, etc.): 4-4

Mica (type, relative amount): 2-4

Textural Soil Description: silt loam

pH _____ CO₃: 01234 SO₄: 01234

% VOIDS

Proctor Results (from _____)

X=MDD _____ lb./ft³ @ _____ % MC.

Y=Dry wt. of test sample _____ gm.

Z=Volume of test sample _____ cc

V_s=Volume of Solids in X

V=Volume of 1 ft.³ = 28317 cc.

$\frac{X}{Y} Z = V_s$ (_____) =

$\frac{V - V_s}{V} = \% \text{ Voids}$ $\frac{28317 - \text{_____}}{28317} =$

24

QUALITATIVE SOILS ANALYSIS

DATE 10-1-90

JOB: Franklin county

ENGINEER/CONTRACTOR: Boisland Const

SOIL SAMPLE I.D. 07291902 (small)

MOISTURE CONTENT (% dry weight, as received)

Tare wt: (#7) 77.31

Wet Gross: 198.39

Wet Net: 121.08

Dry Gross: 195.37

Dry Net: 119.06

MC wt: 3.02 = 2.6 %

PARTICLE SIZE ANALYSIS

Gravel (+10) Test

Tare wt: (#7) 77.31

Wet Gross Wt. Whole Sample 198.39

Wet Net Wt. Whole Sample 121.08

Wet Net Wt. Whole Sample $\times \left(\frac{100 - MC\%}{100} \right) =$ Dry Net Wt. Whole Sample 117.93

Tare Wt: (#7) 77.31

Dry Gross Wt. +10 Sample 22.21 Dry Net Wt. +10 Sample 4.9

Dry Net Wt. +10 Sample \div Dry Net Wt. Whole Sample = +10 4.2 %

Hydrometer Test

| Reading (gms) | Temp. (°F) | Corr. (0.2g/°F) | Corr. (Reading (gm)) | Time off |
|--------------------|------------|-----------------|----------------------|----------------|
| 40 sec. 41 | 67 | -0.2 | 40.8 | |
| 120 min. 10 | 68 | 0 | 10 | 10:40 |
| Wt (gms) | +10 Mesh | -10 Mesh Sand | Silt | Clay |
| | | 9.2 | 30.8 | 10 |
| %(Screened sample) | | 18.4 % | 61.6 % | 20 % |
| %(Whole Sample) | 4.2 % | 95.9 % | 17.7 % | 57.1 % (7.2 %) |

Apparent Organic Material (Roots, etc.): 4-4 roots

Mica (type, relative amount): 2-4

Textural Soil Description: Silt loam

pH _____

CO₃: 01234

SO₄: 01234

% VOIDS

Proctor Results (from _____) 28

X=MDD _____ lb./ft³ @ _____ % MC.

Y=Dry wt. of test sample _____ gm.

Z=Volume of test sample _____ cc

V_s=Volume of Solids in X

V=Volume of 1 ft.³ = 28317 cc.

$$\frac{X}{Y} Z = V_s \quad (\quad) =$$

$$\frac{V - V_s}{V} = \% \text{ Voids} \quad \frac{28317 - \quad}{28317} =$$

2.8 WORK DIRECTIVE CHANGE

No. 1201

PROJECT: FRENCH COLLEGE DATE OF ISSUANCE: 9/6/90
WETLAND / AMR CONTROL

OWNER: MONTANA DEPARTMENT OF STATE LANDS - AMR BUREAU

CONTRACTOR: BOLAN'S CONST. OWNER'S PROJECT NO: DSL/AMRB-90-009 ^{C15}

ENGINEER: SCHAFER & ASSOCIATES

CONTRACT FOR: Mine Reclamation ENGINEER'S PROJECT NO. 073-02

You are directed to proceed promptly with the following change(s):

Description: REMOVE ADDITIONAL FENCE BETWEEN CELLS 2 AND 3.
REMOVE FENCE BOTH SIDES OF PATHWAY FROM ADJACENT ROAD TO INTERSECTION WITH
Purpose of Work Directive Change: ITEM (2) REMOVE FENCE FROM PATHWAY TO UTILITY POLE
EXPOSE KNOB FOR BACKFILL EXCAVATION
PROVIDE CONSTRUCTION ACCESS AND EXPOSE KNOB FOR BACKFILL EXCAVATION
Attachments: (list documents supporting change)
REF. SHEETS OF DRAWINGS (WELLS PIT PLAN)

If a claim is made that the above change(s) have affected Contract Price or Contract Time, any claim for a Change Order based thereon will involve one of the following methods of determining the effect of the change(s).

Method of determining change in Contract Price:

Method of determining change in Contract Time:

- Time and Material
- Unit prices (50 LFF BASIS)
- Cost plus fixed fee
- Other

- Contractor
- Contractor's records
- Engineers's records

Estimated increase (decrease) in Contract Price:

\$ _____

If the change involves an increase, the estimated amount is not to be exceeded without further authorization.

Estimated increase (decrease) in Contract Time:

(0) days. If the change involves an increase, the estimated time is not to be exceeded without further authorization.

RECOMMENDED:

By [Signature]
Engineer

AUTHORIZED:

By [Signature]
Owner

ACCEPTED:

By [Signature]

WORK DIRECTIVE CHANGE

(Instructions on Reverse Side)

No. 002

PROJECT: French Coulee Wetland
AMD Control

DATE OF ISSUANCE: September 24, 1990

CONTRACTOR: Ed Boland Construction
(Name, 4601 7th Ave South
Address) Great Falls, MT 59405

OWNER: Montana Department of State Lands
AMR Bureau

MONT A/E or DSL-AMRB:

CONTRACT FOR: Mine Reclamation

ENGINEER: Schafer and Associates

You are directed to proceed promptly with the following change(s):

Description: 1) Excavate bottom of Cell #2 to 3547.5 feet; place edge of berm on E side of all cells a minimum of 28 feet from west rail of tracks. Over excavate Cells 1 and 2 8" to allow for bentonite liner. Excavate and build berms for all Cells at location, grades and elevations shown on amended plans.

Purpose of Work Directive Change:

- 1) To fit Cells to existing topography and drainage while maintaining integrity of piping system.

Attachments: (list documents supporting change)
See amended plans.

If a claim is made that the above change(s) have affected Contract Price or Contract Time, any claim for a Change Order based thereon will involve one of the following methods of determining the effect of the change(s).

Method of determining change in Contract Price:

- Time and Materials
 Unit Prices
 Cost Plus Fixed Fee
 Other N/A

Method of determining change in Contract Time:

- Contractor's Records
 Engineer's Records
 Other N/A

Estimated increase (decrease) in Contract Price:

\$ N/A. If the change involves an increase, the estimated amount is not to be exceeded without further authorization.

Estimated increase (decrease) in Contract Time: 0 days.

If the change involves an increase, the estimated time is not to be exceeded without further authorization.

RECOMMENDED:

By

Richard Spott
Engineer

ACCEPTED:

By

Contractor

AUTHORIZED:

By

Owner

WORK DIRECTIVE CHANGE

(Instructions on Reverse Side)

No. 003

PROJECT: French Coulee Wetland
AMD Control

DATE OF ISSUANCE: September 24, 1990

CONTRACTOR: Ed Boland Construction
(Name, 4601 7th Ave South
Address) Great Falls, MT 59405

OWNER: Montana Department of State Lands
AMR Bureau

MONT A/E or DSL-AMRB:

CONTRACT FOR: Mine Reclamation

ENGINEER: Schafer and Associates

You are directed to proceed promptly with the following change(s):

- Description:
- 1) Change location of 8" PVC main line as shown on Supplemental Drawing 2.
 - 2) Change 4" main cleanout design and location as shown on Supplemental Drawing 4.
 - 3) change from use of butterfly valves (2) to ten (10), 4" acid resistant ball valves as shown on Supplemental Drawing Nos. 2, 3, and 4.

Purpose of Work Directive Change:

- 1) To maintain designed head in main line, provide for easier access and cleanout of main line and reduce overall depth of main burial.

Attachments: (list documents supporting change)

See Supplemental Drawing Nos. 2, 3, and 4.

If a claim is made that the above change(s) have affected Contract Price or Contract Time, any claim for a Change Order based thereon will involve one of the following methods of determining the effect of the change(s).

Method of determining change in Contract Price:

Time and Materials

Unit Prices

Cost Plus Fixed Fee

Other _____

Method of determining change in Contract Time:

Contractor's Records

Engineer's Records

Other _____

Estimated increase (decrease) in Contract Price:

\$ _____. If the change involves an increase, the estimated amount is not to be exceeded without further authorization.

Estimated increase (decrease) in Contract Time: 1 days.

If the change involves an increase, the estimated time is not to be exceeded without further authorization.

RECOMMENDED:

By _____

Engineer

ACCEPTED:

By _____

Contractor

AUTHORIZED:

By _____

Owner

WORK DIRECTIVE CHANGE

(Instructions on Reverse Side)

No. 004

PROJECT: French Coulee Wetland
AMD Control

DATE OF ISSUANCE: September 24, 1990

CONTRACTOR: Ed Boland Construction
(Name, 4601 7th Ave South
Address) Great Falls, MT 59405

OWNER: Montana Department of State Lands
AMR Bureau

MONT A/E or DSL-AMRB:

CONTRACT FOR: Mine Reclamation

ENGINEER: Schafer and Associates

You are directed to proceed promptly with the following change(s):

Description: 1) Connect and tie into 8" main, a 4" PVC pipe discharging AMD located on west side project area between Cells 1 and 2.

Purpose of Work Directive Change:

1) To treat this source of AMD in wetland.

Attachments: (list documents supporting change)

See Supplemental Drawing 2.

If a claim is made that the above change(s) have affected Contract Price or Contract Time, any claim for a Change Order based thereon will involve one of the following methods of determining the effect of the change(s).

Method of determining change in Contract Price:

Time and Materials

Unit Prices

Cost Plus Fixed Fee

Other N/A

Method of determining change in Contract Time:

Contractor's Records

Engineer's Records

Other _____

Estimated increase (decrease) in Contract Price:

\$ N/A. If the change involves an increase, the estimated amount is not to be exceeded without further authorization.

Estimated increase (decrease) in Contract Time: 1 days.

If the change involves an increase, the estimated time is not to be exceeded without further authorization.

RECOMMENDED:

By

ACCEPTED:

By

Engineer

Contractor

AUTHORIZED:

By

Owner

WORK DIRECTIVE CHANGE

(Instructions on Reverse Side)

No. 005

PROJECT: French Coulee Wetland
AMD Control

DATE OF ISSUANCE: September 24, 1990

CONTRACTOR: Ed Boland Construction
Lands
(Name, 4601 7th Ave South
Address) Great Falls, MT 59405

OWNER: Montana Department of State
AMR Bureau

MONT A/E or DSL-AMRB:

CONTRACT FOR: Mine Reclamation

ENGINEER: Schafer and Associates

You are directed to proceed promptly with the following change(s):

Description: 1) Build flumes and associated piping (manifolds, bypass, etc.) as shown on Supplemental Drawing 1a, 1b, 1c, and 1d. Change number of stopplates and other material quantities as per drawings.

Purpose of Work Directive Change:

1) To make individual flume design consistent with As-Built main and piping/plumbing.

Attachments: (list documents supporting change)

See Supplemental Drawing Nos. 1a, 1b, 1c and 1d.

If a claim is made that the above change(s) have affected Contract Price or Contract Time, any claim for a Change Order based thereon will involve one of the following methods of determining the effect of the change(s).

Method of determining change in Contract Price:

- Time and Materials
- Unit Prices
- Cost Plus Fixed Fee
- Other N/A

Method of determining change in Contract Time:

- Contractor's Records
- Engineer's Records
- Other N/A

Estimated increase (decrease) in Contract Price:

\$ N/A. If the change involves an increase, the estimated amount is not to be exceeded without further authorization.

Estimated increase (decrease) in Contract Time: 0 days.
If the change involves an increase, the estimated time is not to be exceeded without further authorization.

RECOMMENDED:

By

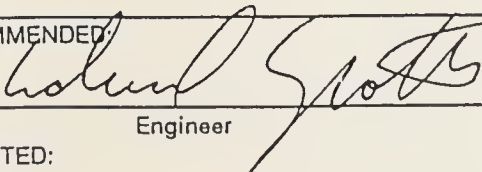

Engineer

ACCEPTED:

By

Contractor

AUTHORIZED:

By

Owner

WORK DIRECTIVE CHANGE

INSTRUCTIONS

A. GENERAL INFORMATION

This document was developed for use in situations involving changes in the Work which, if not processed expeditiously, might delay the Project. These changes are often initiated in the field and may affect the Contract Price or the Contract Time. This is not a Change Order, but only a directive to proceed with Work that may be included in a subsequent Change Order.

For supplemental instructions and minor changes not involving a change in the Contract Price or the Contract Time, a Field Order may be issued.

B. COMPLETING THE WORK DIRECTIVE CHANGE

Engineer initiates the form, including a description of the items involved and attachments.

Based on conversations between Engineer and Contractor, Engineer completes the following:

METHOD OF DETERMINING CHANGE, IF ANY, IN CONTRACT PRICE: Mark the method to be used in determining the final cost of Work involved and the net effect on the Contract Price. If the change involves an increase in the Contract Price and the estimated amount is approached before the additional or changed work is completed, another Work Directive Change must be issued to change the amount of Contractor may stop the changed Work when the estimated time is reached. If the Work Directive Change is not likely to change the Contract Price, the space for estimated increase (decrease) should be marked "Not Applicable".

METHOD OF DETERMINING CHANGE, IF ANY, IN CONTRACT TIME: Mark the method to be used in determining the change in Contract Time and the estimated increase or decrease in Contract Time. If the change involves an increase in the Contract Time and the estimated time is approached before additional or changed Work is completed, another Work Directive Change must be issued to change the time or Contractor may stop the changed Work when the estimated time is reached. If the Work Directive Change is not likely to change the Contract Time, the space for estimated increase (decrease) should be marked "Not Applicable".

Once Engineer has completed and signed the form, all copies should be sent to Owner for authorization because Engineer alone does not have authority to authorize changes in price or time. Once authorized by Owner, a copy should be sent by Engineer to Contractor.

Once the Work covered by this directive is completed for final cost and time determined, Contractor should submit documentation for inclusion in a Change Order.

THIS IS A DIRECTIVE TO PROCEED WITH A CHANGE THAT MAY AFFECT THE CONTRACT PRICE OR THE CONTRACT TIME. A CHANGE ORDER, IF ANY, SHOULD BE CONSIDERED PROMPTLY.

Supplemental
Drawing # 4

TCH
9/13/90
Revised 9/24/90
2.5

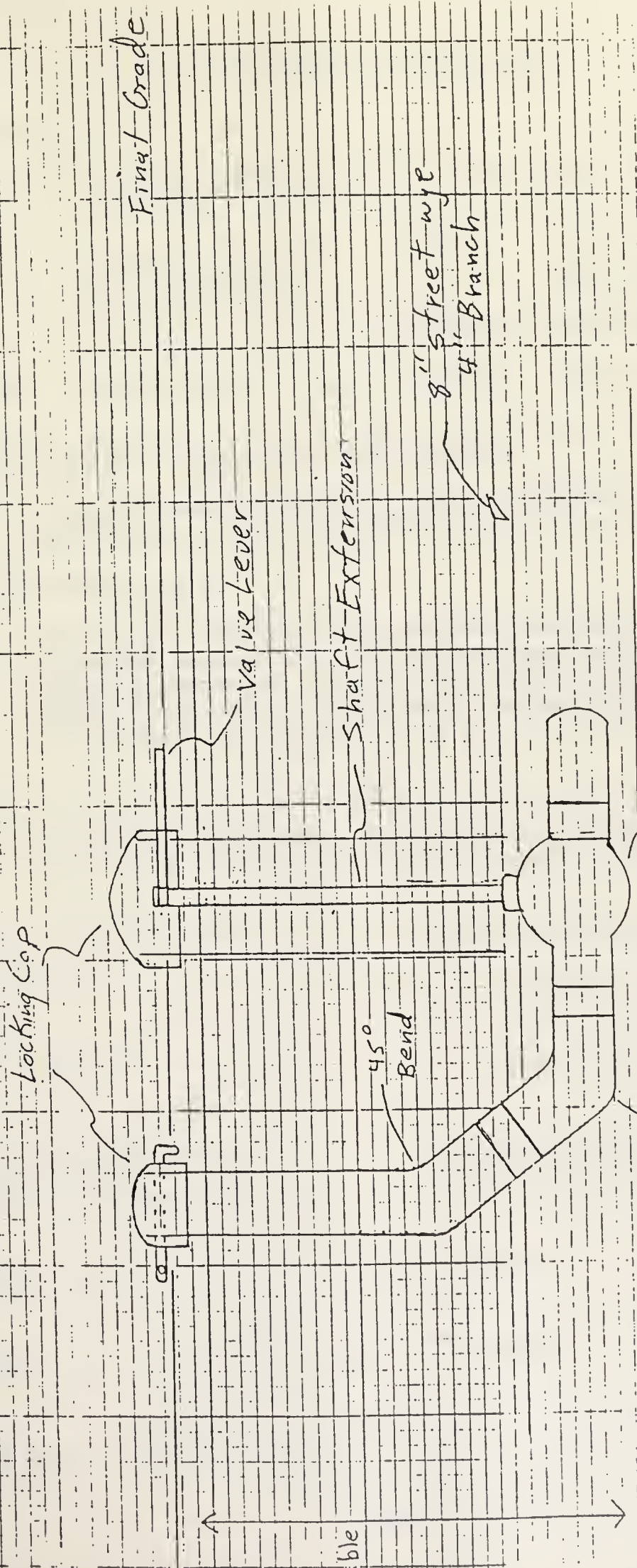

1964

RECEIVED

RECEIVED

AMERICAN ...

...

...

...

...

...

...

...

...

...

...

...

...

...

...

...

...

...

...

...

...

...

...

...

...

...

...

WORK DIRECTIVE CHANGE

No. WD-07

(Instructions on Reverse Side)

PROJECT: French Coulee Wetland
AMD Control

DATE OF ISSUANCE: 11/30/90

CONTRACTOR: Ed Boland Construction
(Name, 4601 7th Ave South
Address) Great Falls, MT 59401

OWNER: Montana Dept of State Lands
AMR Bureau

MONT A/E or DSL-AMRB: 90-010

CONTRACT FOR: Mine Reclamation

ENGINEER: Schafer and Associates

You are directed to proceed promptly with the following change(s):

Description: Install approximately 350 feet of 8 inch PVC pipeline buried to a minimum depth of 4 feet from Cell 2 discharge flume to Cell 3 inlet flume in lieu of lined ditch.

Purpose of Work Directive Change:

The lined ditch will tend to collect wind-blown debris which may require frequent cleanout and increases the possibility for introducing foreign matter to the wetland buried distribution piping. In addition school children use this area when going to and from the bus stop on Anaconda Road. A pipe will not require the development of a footbridge or culvert to maintain easy access across this area.

Attachments:

If a claim is made that the above change(s) have affected Contract Price or Contract Time, any claim for a Change Order based thereon will involve one of the following methods of determining the effect of the change(s).

Method of determining change in Contract Price:

- Time and Materials
- Unit Prices
- Cost Plus Fixed Fee
- Other _____

Estimated increase (decrease) in Contract Price:
\$ 900.00. If the change involves an increase,
the estimated amount is not to be exceeded without further
authorization.

Method of determining change in Contract Time:

- Contractor's Records
- Engineer's Records
- Other _____

Estimated increase (decrease) in Contract Time: 0 days.
If the change involves an increase, the estimated time is not
to be exceeded without further authorization.

RECOMMENDED:

By _____
Engineer

ACCEPTED:

By _____
Contractor

AUTHORIZED:

By _____
Owner

