

HERP
QL
668
.E257
D84
1999

Scientific Papers

Natural History Museum
The University of Kansas

30 July 1999

Number 13:1-78

Frogs of the Genus *Eleutherodactylus* (Anura: Leptodactylidae) in the Andes of Northern Peru

By

WILLIAM E. DUELLMAN AND JENNIFER B. PRAMUK

Natural History Museum and Biodiversity Research Center, and Department of Ecology and Evolutionary Biology,
The University of Kansas, Lawrence, Kansas 66045-2454, USA.

CONTENTS

ABSTRACT	2
RESUMEN	2
INTRODUCTION	3
ACKNOWLEDGMENTS	3
MATERIALS AND METHODS	3
ANDES OF NORTHERN PERU	4
GEOLOGICAL HISTORY	4
PHYSIOGRAPHY	5
CLIMATE	5
VEGETATION	8
GENERA OF ELEUTHERODACTYLIINE FROGS	10
SUMMARY OF TAXONOMIC CHARACTERS	11
IDENTIFICATION OF SPECIES	17
KEY TO THE SPECIES	17
CLAVE DE LAS ESPECIES	18
ACCOUNTS OF SPECIES	20
<i>ELEUTHERODACTYLUS CONSPICILLATUS</i> GROUP	20
<i>ELEUTHERODACTYLUS NIGROVITTATUS</i> GROUP	33
<i>ELEUTHERODACTYLUS ORESTES</i> GROUP	35
<i>ELEUTHERODACTYLUS UNISTRIGATUS</i> GROUP	41
BIOGEOGRAPHY	69
LITERATURE CITED	72
APPENDICES	75
SPECIMENS EXAMINED	75
GAZETTEER	77

ABSTRACT We recognize 45 species in the leptodactylid frog genus *Eleutherodactylus* in the Andes of northern Ecuador. Twenty-one of these species have been known previously from Peru, but three of them are reported for the first time from the Andes. Six other species known previously from Ecuador are recorded for the first time in Peru, and 18 species are described as new. The majority (31) of the 45 species are members of the large *Eleutherodactylus unistrigatus* group, and nine species belong to the *Eleutherodactylus conspicillatus* group; one species belongs to the *Eleutherodactylus nigrovittatus* group, and four Peruvian species are in the *Eleutherodactylus orestes* group, which otherwise is known from three species in the Andes of southern Ecuador. Each species is treated in an account that includes a diagnosis, description or reference to a description, habitat, and distribution. Keys in English and Spanish to the species in the Andes of northern Peru are provided; 16 species are illustrated in color.

In the Andes of southern Ecuador and northern Peru, all members of the *Eleutherodactylus conspicillatus* group occur at elevations of less than 1500 m, but two species extend to elevations in excess of 2000 m. Members of the *Eleutherodactylus nigrovittatus* and *orestes* groups mostly are confined to elevations above 3000 m, whereas species in the *Eleutherodactylus unistrigatus* group range throughout the elevations in the Andes to 3200 m. Among the isolated mountain ranges in northern Peru, the Cordillera del Cóndor has the largest number of species of *Eleutherodactylus* (19); of these, 11 are shared with Cordillera Oriental in Ecuador, nine with the Cordillera de Cutucú in Ecuador, and only five are among the 16 species known from the northern part of the Cordillera Central in Peru. The Cordillera Colán has five species of *Eleutherodactylus*; one is shared with the Cordillera Oriental in Ecuador and another with the Cordillera Central in Peru. Of the 11 species inhabiting the Cordillera de Huancabamba, three are shared with the Cordillera Occidental in Ecuador, two with the Cordillera Oriental in Ecuador, and two with the Cordillera Occidental in Peru. The absence of collections of *Eleutherodactylus* from many mountain ranges in northern Peru suggests that the number of species far exceeds that reported here.

Key Words: Leptodactylidae, *Eleutherodactylus*, Andes of northern Peru, Taxonomy, Biogeography.

RESUMEN Reconocemos 45 especies en el género leptodactílido *Eleutherodactylus* en los Andes del norte Perú. Vientiuna de estas especies eran conocidas previamente para Perú, pero tres de ellas se reportano por primera vez para los Andes. Otras seis especies conocidos para Ecuador son reportadas por primera vez para Perú, y 18 especies son descritas como nuevas. La mayoría (31) de las 45 especies son miembros del grupo *Eleutherodactylus unistrigatus*, y nueve especies pertenecen al grupo *Eleutherodactylus conspicillatus*; una especie pertenece al grupo *Eleutherodactylus nigrovittatus*, y cuatro especies peruanas están en el grupo *Eleutherodactylus orestes*, el cual también es conocido por tres especies en los Andes del sur de Ecuador. Para cada una de las especies se realiza un resumen que uncluye diagnosis, descripción o referencia a una descripción, habitat y distribución geográfica. Se proveen claves en ingles y español para la identificación de las especies en los Andes del norte de Perú; 16 especies se ilustradan a color.

En los Andes del sur de Ecuador y el norte de Perú, todos los miembros del grupo *Eleutherodactylus conspicillatus* se encuentran en elevaciones menores a 1500 m, pero dos especies se extienden hasta elevaciones mayores a 2000 m. Miembros de los grupos *Eleutherodactylus nigrovittatus* y *Eleutherodactylus orestes* están restringidos a elevaciones mayores de 3000 m, mientras que especies en el grupo *Eleutherodactylus unistrigatus* se extienden por todas las elevaciones de los Andes hasta los 3200 m. Entre las cordilleras aisladas en el norte del Perú, la Cordillera del Cóndor tiene el número más grande de especies de *Eleutherodactylus* (19); de estas, 11 se encuentran también en la Cordillera Oriental en Ecuador, nueve en la Cordillera de Cutucú en Ecuador, y solamente cinco están entre las 16 especies conocidas en el parte norte de la Cordillera Central en Perú. La Cordillera Colán tiene cinco especies de *Eleutherodactylus*; una ocurre también en la Cordillera Oriental en Ecuador y otra en la Cordillera Central en Perú. De las 11 especies que habitan la Cordillera de Huancabamba, tres ocurren también en la Cordillera Occidental en Ecuador, dos en la Cordillera Oriental en Ecuador, y dos en la Cordillera Occidental en Perú. La ausencia de colecciones de *Eleutherodactylus* de muchas cordilleras en el norte de Perú sugiere que el número de especies excede en mucho al que aquí se reporta.

Palabras claves: Leptodactylidae, *Eleutherodactylus*, Andes del norte de Perú, Taxonomía, Biogeografía.

INTRODUCTION

Frogs of the genus *Eleutherodactylus* are speciose in the cloud forests on the slopes of the Andes in Ecuador and Colombia (Lynch et al., 1997; Lynch and Duellman, 1980, 1997). Several species of *Eleutherodactylus* have been described from cloud forests on the Amazonian slopes of the Andes in southern Peru (Duellman, 1978a, b), but until recently, few species have been recorded from northern Peru. The first were *E. cajamarcensis* and *E. lynmani*, which were collected by G. K. Noble in 1916 and described by Barbour and Noble (1920); both species are now known to be rather widely distributed in northwestern Peru and southwestern Ecuador (Lynch and Duellman, 1997). More than half a century passed until more collections were made in the Andes in northern Peru.

Field parties from The University of Kansas collected amphibians and reptiles in the Andes of northern Peru in 1979, 1989, and 1991, and field parties from Louisiana State University obtained specimens from the Cordillera de Huancabamba in 1974 and the Cordillera Colán in 1978. Likewise field parties from the University of Florida obtained specimens in 1970 and 1972. Rainer Schulte, a resident of Tarapoto, Peru, and his field companions collected several species of amphibians from the eastern slopes of the Andes and outlying ranges, as well as the southern slopes of the Cordillera del Cóndor. Alfonso Miranda of the Universidad Nacional Cajamarca, Peru, obtained specimens in the northern part of the Cordillera Occidental, and Javier Icochea and Robert P. Reynolds collected several species on the eastern slopes of the Cordillera del Cóndor in 1994. Material resulting from these field expeditions led to the descriptions of nine new species of *Eleutherodactylus*—*E. schultei* (Duellman, 1990a) and *E. lirellus* (Dwyer, 1995) from the Cordillera Central, *E. petrobardus* (Duellman, 1991a) from the Cordillera Occidental, *E. bearsei* (Duellman, 1992a) and *E. citriogaster* (Duellman, 1992b) from eastern outliers of the Andes in Departamento San Martín, and *E. ceuthospilus*, *rhodoplichus*, *sternothylax*, and *wiensi* from the Cordillera de Huancabamba (Duellman and Wild, 1993). The latter authors also provided the first Peruvian records for three species (*E. colodactylus*, *cryptomelas*, and *phoxocephalus*) previously known only from Ecuador. Reynolds and Icochea (1997) reported the first Peruvian locality for *E. condor*, previously only known from Ecuador, and provided the first locality for *E. peruvianus* from the Andes of northern Peru. Flores and Rodríguez (1997) described *E. karcharias* from the northern part of the Cordillera Central. Thus, 17 spe-

cies have been reported from the Andes of northern Peru.

Among the collections of *Eleutherodactylus* from northern Peru are specimens of 18 more unnamed species, as well as examples of six species known from Ecuador but previously not reported from Peru. The purposes of this paper are to present descriptions of the new species and to provide a review of the species of *Eleutherodactylus* known to occur in the Andes and associated mountain ranges in northern Peru—departamentos Amazonas, Cajamarca, Piura, and San Martín. Despite the large number of species now known from the region, our knowledge of anurans in the Andes of northern Peru is rudimentary. More thorough collecting surely will expand the presently known ranges of many species, and the exploration of previously uncollected, isolated mountain ranges certainly will reveal additional species. We would not be surprised if the present number represents no more than half of the eleutherodactyline fauna of northern Peru.

ACKNOWLEDGMENTS

Duellman is indebted to his field companions—Thomas J. Berger, David C. Cannatella, Fernando M. Cuadros V, Michael E. Morrison, Rainer Schulte, and John J. Wiens—whose efforts contributed greatly to the amount of material available for study, to many residents of northern Peru who provided shelter, food, and assistance to the field parties, and to B. Anthony Luscombe of Lima, and Rainer Schulte of Tarapoto for logistical support. For the loan of specimens, we are grateful to David L. Auth of the Florida State Museum; Frank T. Burbrink, David A. Good, and Douglas A. Rossman of Louisiana State University; and Robert P. Reynolds of the National Museum of Natural History. We are grateful to Rainer Schulte for providing photographs of one species, Erik R. Wild for measuring many of the specimens and to Analía Púgener for considerable help with the Resumen and key in Spanish. The manuscript benefited from critical review by S. Blair Hedges and John D. Lynch and careful editing by Linda Trueb; we thank them profusely for their efforts. Permits for the collection and exportation of specimens were issued by Luis J. Cueto Aragón, Armando Pimental Bustamento, Gonzalo Bravo Mejía Muñoz, and José Purisaca, Dirección General Forestal y de Fauna, Ministerio de Agricultura, Lima, Peru. The research reported herein is part of a study on patterns of speciation and biogeography of Andean anurans supported by a grant (BSR 8805920) from the National Science Foundation (W. E. Duellman, P.I.).

MATERIALS AND METHODS

Specimens in museum collections are identified by their catalogue numbers preceded by the following codes: ANSP

= Academy of Natural Sciences of Philadelphia; BM = British Museum (Natural History); KU = Natural History

Museum, University of Kansas; LSUMZ = Museum of Zoology, Louisiana State University; MCZ = Museum of Comparative Zoology, Harvard University; MHNSM = Museo de Historia Natural, Universidad Nacional Mayor de San Marcos, Lima, Peru; MNCN = Museo Nacional de Ciencias Naturales, Madrid, Spain; NHMG = Naturhistoriska Museet Göteborg, Sweden; NHRM = Naturhistoriska Riksmuseet, Stockholm, Sweden; MSNT = Museo e Instituto di Zoologia Sistematica, Università di Torino, Italy; USNM = National Museum of Natural History; UF = Florida State Museum, University of Florida, Gainesville. All specimens from northern Peru and Ecuador that have been studied are listed in Appendix 1. Localities from which specimens have been examined are listed with their geographic coordinates and elevations in Appendix 2.

Measurements, definitions of structural characters, and numbered characteristics in diagnoses follow the methods of Lynch and Duellman (1997). Diagnoses of *E. bromeliaceus*, *colodactylus*, *cryptomelas*, *proserpens*, and *versicolor* were modified from those of Lynch (1979), and those of *E. cajamaricensis*, *lymani*, and *phoxocephalus* were taken from Lynch and Duellman (1997), whereas those of *E. incomptus*, *condor*, *galdi*, *ockendeni*, and *peruvianus* were modified from those of Lynch and Duellman (1980) and that of *E. pecki* from Duellman and Lynch (1988).

A major problem in providing adequate diagnoses of *Eleutherodactylus* is the comparison of new taxa with the plethora of existing species. In order to be able to ascertain character states among the many species that might be confused with the species described or discussed herein, we tabulated character states for all diagnostic characters

used by Lynch and Duellman (1997). For the purposes of this study, we included all described species of *Eleutherodactylus* from Peru and Ecuador, as well as the new taxa; it is extremely unlikely that species from any other region occur in northern Peru. To the nonspecialist, it may seem that we have elaborated unnecessarily the diagnoses of all of the taxa and the descriptions of the new taxa. However, the distinction between specimens of many species of *Eleutherodactylus* is difficult even for the specialist. We present detailed diagnoses and descriptions in an endeavor to facilitate comparisons with other taxa that certainly will be discovered in the future.

Measurements were taken with dial calipers to the nearest 0.1 mm. If sex and reproductive condition were not evident externally (nuptial pads or vocal sacs in males and eggs visible through the body wall in females), sex and reproductive condition were determined by dissection. The following abbreviations are used: E-N = eye-nostril distance; HL = head length; HW = head width; IOD = interorbital distance; SVL = snout-vent length. Photographs noted as (ERW) were taken by Erik R. Wild; all others were taken by Duellman.

Except for the sites visited by Reynolds and Icochea, who used GPS devices, geographical coordinates were obtained from maps, principally the Mapa Físico Político, 1:1,000,000 (1973) but also the Carta Nacional del Peru, 1:100,000 (1986) for those regions so mapped; both sets of maps were produced by the Instituto Geográfico Militar del Peru. Coordinates for Ecuadorian localities were obtained from the 1974 edition of the Mapa de Ecuador, 1:1,000,000, produced by the Instituto Geográfico Militar, Quito. Elevations were obtained by altimeters or in some cases from maps.

ANDES OF NORTHERN PERU

Equaled in heights and expanse only by the Himalayas, the majestic Andean mountain chain was described by Enock (1907) as: "Heavenward thrown, crumpled, folded, ridged and fractured, with gleaming 'porcelain' gnomons pointing to the sun; shattered strata and shear crevasse; far terraces and grim escarpments, hung over with filmy mist-veils, and robed with the white clothing of crystalised rains and mists; the birthplace of the winds and hails; the father of rivers whose floods are borne a thousand leagues away—the mighty cordillera is!" This description is especially appropriate for the Andes of northern Peru (departamentos Amazonas, Cajamarca, Piura, and San Martín), where north-south mountain ranges are separated by deep valleys.

GEOLOGICAL HISTORY

In northern Peru and southern Ecuador, a major structural and physiographic break exists in the Andes (Figs. 1,

2); this is the Huancabamba Depression, a complex system of relatively low ridges, basins, and valleys. Therein is the lowest pass in the Andes between Colombia and southern Chile—Abra de Porculla at 2145 m. In the Huancabamba Depression, there is a structural deflection of the Andean faults that corresponds to two major tectonic segments of the Andes (Sillitoe, 1974). South of the depression the axis of the Andes is northwest to southeast; north of the depression the axis is north-northeast-south-southwest.

Geological evidence points to extensive marine transgressions in the region of the Huancabamba Depression during the Cretaceous (Ham and Herrera, 1963). Orogenic events associated with plate tectonics along the west coast of South America in the Late Cretaceous resulted in the uplift of the Andes to elevations probably not exceeding 1000 m above sea level (Zeil, 1979). The major uplift of the

Andes south of the depression was in the Miocene (Harrington, 1962; Aubodin et al., 1973; Sempere et al., 1990); the final major uplift was in the Pliocene with some additional orogeny in the Pleistocene (James, 1973; Gansser, 1973; Noble et al., 1990). In contrast, the uplifted terrain resulting from the Late Cretaceous orogeny subsequently was eroded to low hills before the major uplift of the Andes north of the Huancabamba Depression was initiated in the Pliocene; this uplift continued into the Quaternary, as evidenced by many active volcanoes in Ecuador and Colombia (Herd and Naeser, 1974; Sauer, 1971; Shagam, 1975; Simpson, 1979). Thus, the Huancabamba Depression is not only a physiographic anomaly in the Andes and a tectonic border, but it bridges tectonic segments that were uplifted at different times.

The present elevations and drainage patterns in the Andes of northern Peru and the Huancabamba Depression probably were achieved in the Pleistocene (Gansser, 1973; Harrington, 1956). During the Pleistocene, climatic fluctuations included cooler, drier conditions during glacial phases, and warmer, more moist conditions during interglacial phases. According to Sauer (1971), during interglacials, climates were depressed 1500–2000 m in the Ecuadorian Andes, whereas in the Peruvian Andes they were depressed 1000–1500 m on the eastern slopes and 500–1000 m on the western slopes (Hastenrath, 1967; Dollfus, 1976). These postulated changes are in accord with the paleoecological work in Colombia by van der Hammer (1974), van der Hammen and Cleef (1986), and Clapperton (1987), and in the Ecuadorian Andes by Colinvaux (1988). These climatic fluctuations presumably resulted in alternating isolation and interconnection of montane environments, thereby providing corridors for, and barriers to, dispersal in the Andes (Simpson, 1979; Colinvaux, 1993).

PHYSIOGRAPHY

A casual glance at a physiographic map of South America reveals the long Andean mountain chain bordering the west side of the continent; as such, one might expect major drainages to be east and west. Although there are many rivers originating in the Andes, some of the most significant drainages are north and south. This is especially evident in Colombia where the Río Magdalena and Río Cauca form broad valleys between three major north-south cordilleras.

Between the Nudo de Pasto (Macizo Colombiano) in southern Colombia, the Andes are formed by two major ranges in Ecuador—the western Cordillera Occidental and the eastern Cordillera Oriental. Between the eastern and western cordilleras are 10 basins that are completely or partially separated by transverse ridges that in most cases connect the cordilleras. South of the dry valley of the Río

Jubones, the Cordillera Occidental diminishes in isolated ranges, such as the Estribaciones de Celica. On the other hand, the Cordillera Oriental is continuous with the Cordillera de Huancabamba and Cordillera de Tabacones in northern Peru, both of which terminate north of the Río Chamaya, a tributary of the Río Marañón (Fig. 2).

In Peru, the Cordillera Occidental forms the backbone of the Andes; it is confluent with the Cordillera Oriental at the Nudo de Pasco. To the north of the Nudo de Pasco, the valley of the Río Marañón separates the Cordillera Central from the Cordillera Occidental. The northern part of the Cordillera Oriental is separated from the Cordillera Central by the valley of the Río Huallaga, which, as it curves eastward, forms the northern boundary of the Cordillera Oriental. Thus the easternmost range of the Andes in Peru north of about 7° S Lat. is the Cordillera Central.

In southern Ecuador and northern Peru, the complex topography is associated with north and south drainages (Fig. 2). For example, the Cordillera del Cóndor is bordered on the west by the Río Narangaritzá (flowing northward) and on the east by the Río Cenepa (flowing southward). The major drainage system in the region is the Río Marañón, which at its confluence with the Río Huallaga forms the Río Amazonas. With the exception of the Río Chamaya, the major tributaries of the Río Marañón flow southward (e.g., Río Huancabamba, Río Cenepa, Río Chinchipe) or northward (e.g., Río Chotano, Río Utcubamba, Río Chiriaco). These rivers separate distinct north-south mountain ranges (e.g., Cordillera de Huancabamba, Cordillera Colán; Fig. 3). The change in direction (from north to east) of the Río Marañón forms the northern boundary of the Cordillera Central. The northern part of the Cordillera Central is dissected by rivers that flow northward (Río Chiriaco and Río Utcubamba) and southward (Río Mayo). The resulting complex topography contains major isolated highland areas (e.g., Cordillera Colán) and the high elevations to the east of the Río Mayo; many ridges more than 1000 m above sea level extend southward almost to the Río Huallaga. Unlike other mountain ranges in the region, the highest parts of the Cordillera del Cóndor consist of sandstone table mountains (Foster and Beltran, 1997).

CLIMATE

Temperature is dependent primarily on elevation. In the lower valley of the Río Marañón, temperatures may exceed 40°C. At high elevations (> 3000 m), mean monthly temperatures are relatively constant throughout the year, but the daily fluctuation can be as much as 20°C with nocturnal lows below freezing (Schwerdtfeger, 1976).

Rainfall patterns are determined by wind patterns and topography. The prevailing winds from the Amazon Ba-

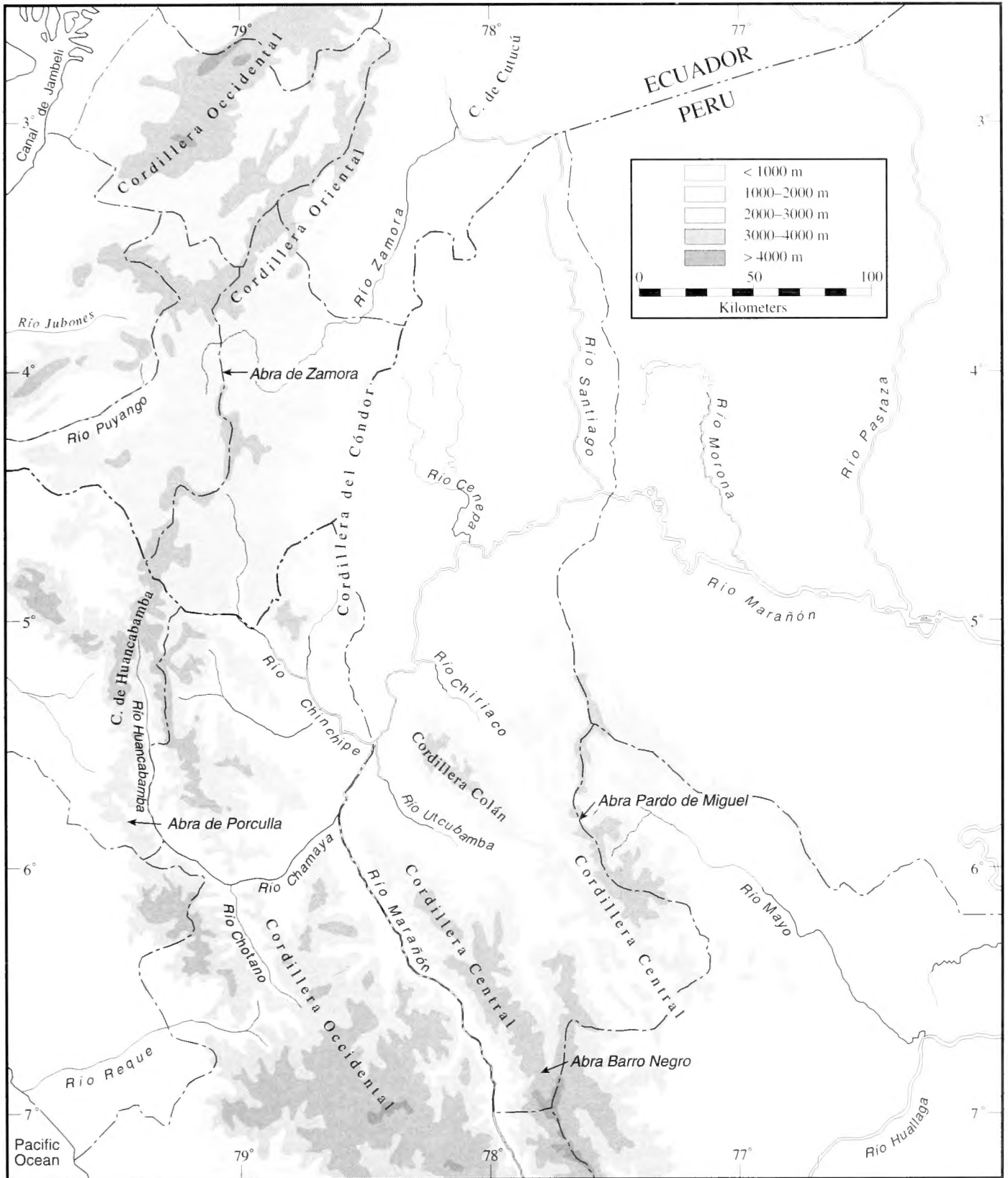

Fig. 2. Physiographic map of the Andes of northern Peru and southern Ecuador.

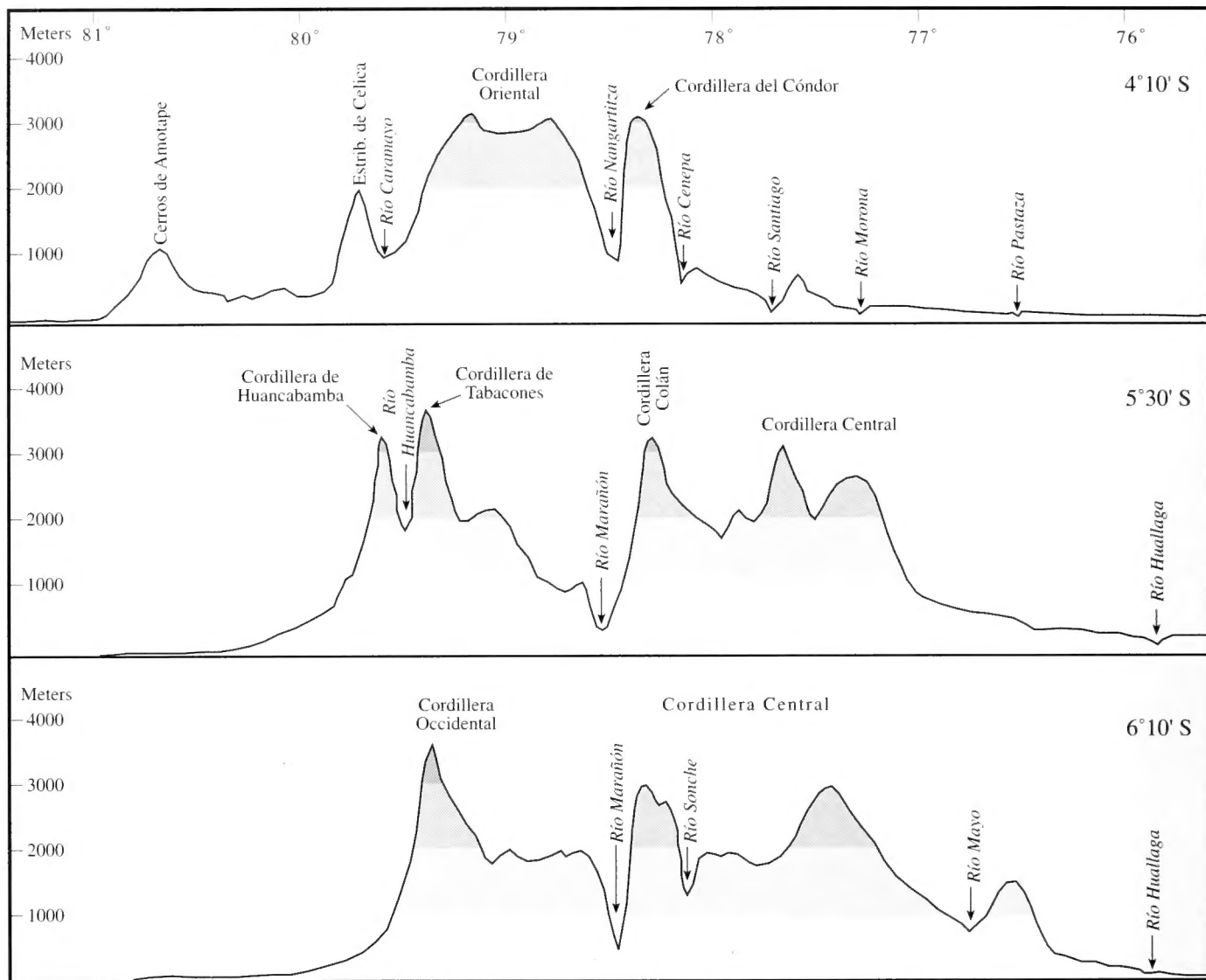

Fig. 3. Profiles of the Andes in southern Ecuador and northern Peru. Vertical exaggeration 35X.

sin bring moisture to the eastern slopes of the mountain ranges throughout the region. Generally rainfall is highest (± 2500 mm annually) at elevations of 500–1500 m on the windward slopes and lower at higher elevations and on the leeward slopes. Deep valleys, such as those of the Río Marañón and its tributaries in the Huancabamba Depression are in rain shadows and receive only 250–500 mm of rain annually; most of this falls in October–May.

Influenced by the cold Humboldt Current, the winds blowing off of the Pacific Ocean have relatively little moisture; some of this moisture is dissipated as fog on the dry western flanks of the Cordillera Occidental, where annual precipitation may be less than 150 mm. However, as noted by Foster and Beltran (1997), the relatively low passes in the western cordilleras permit the westerlies to provide

rainfall on the higher mountains to the east (e.g., Cordillera del Cóndor and Cordillera de Huancabamba). Of course, the former receives its greatest rainfall from the winds off the Amazon Basin. Sporadically, rainfall is increased along the Pacific lowlands and on the western slopes of the Andes by the southward movement of the warm waters of the counter-equatorial current, El Niño.

VEGETATION

The complex topography and associated climatic patterns result in a great variety of vegetation formations. Herein we use the terminology for vegetation formations (and associated maps) in Peru proposed by Tosi (1960, based on Holdridge's [1967] classification) and extend these into Ecuador, as classified and mapped by Cañadas (1983). As noted by Savage (1975) and Lynch and Duellman (1997), the Holdridge system seems to be too sophisticated

for determining broad patterns of animal distribution. Therefore, we have simplified the terminology by combining some of the categories.

A transect from west to east across northern Peru at approximately 05°30' S. Lat. begins in coastal desert, ascends dry, rocky, slopes to humid highlands, drops to an arid valley and repeats this sequence until descending into the Amazonian lowlands. In making this transect, one passes through dry scrub forest, dry montane forest, humid montane forest, and lowland rainforest. Each of the major vegetation formations in northern Peru is discussed briefly below; Tosi's (1960) terminology is in parentheses.

Desert scrub.—(Desierto subtropical y tropical; Maleza desértica subtropical y tropical). Essentially, the entire Pacific lowlands of Peru is extremely dry; with annual rainfall less than 150 mm, only a few xeric-adapted plants are present. In the drier regions, vegetation may be absent or consist only of a terrestrial gray *Tillandsia*. Farther inland and close to the base of the Andes, vegetation becomes more diverse with legumes (e.g., *Prosopis juliflora* and *Capparis* sp.) and cacti (e.g., *Cereus*, *Lemairocereus*, and *Opuntia*).

Thorn forest.—(Bosque espinosa subtropical y tropical). In regions receiving up to 500 mm of rainfall annually, this type of forest develops on the western slopes of the Cordillera Occidental to elevations of about 1200 m. It also is prevalent in the interior valleys of the ríos Chamaya, Chinchipe, Huancabamba, Marañón, and Utcubamba, as well as in the Catamayo Basin in Ecuador. Trees consist principally of legumes (*Prosopis* and *Acacia*) with other drought-resistant trees especially near streams—*Bombax*, *Bursera*, *Jacaranda*, and *Pithecolobium*. Cacti (*Cereus*, *Opuntia*, and *Lemairocereus*) are numerous, especially in the middle Marañón Valley, where dense cactus forest predominates. Both terrestrial and arboreal bromeliads (e.g., *Tillandsia*) are locally abundant. In many areas, especially near rivers, there are irrigated fields of rice or sugar cane.

Dry forest.—(Bosque seco tropical; Bosque muy seco tropical; bosque seco subtropical). Occurring peripheral to the thorn forests in the interior river valleys and in the rain shadow in the lower Río Mayo Valley, there is a forest that develops in areas receiving 500–1000 mm of rain annually. This forest has no closed canopy and is made up of moderate-sized trees of diverse genera (e.g., *Bauhinia*, *Bombax*, *Bursera*, *Cordia*, *Centrolobium*, *Curatella*, *Inga*, *Pithecolobium*, *Tabebuia*). The epiphytic Spanish moss (*Tillandsia usneoides*) is prevalent locally, and both terrestrial and arboreal bromeliads (e.g., *Pitcairnia* and *Tillandsia*) are abundant locally. In the lower Río Mayo Valley and extending to the middle part of the Río Huallaga, the dry forest receives more rainfall (1000–2000 mm annually). In this region, the forest contains several genera of trees (e.g.,

Brosimum, *Cedrela*, *Myroxylon*, *Swietenia*) characteristic of humid tropical forest.

Montane dry forest.—(Bosque seco montano bajo). Isolated patches of this forest occur at elevations of 2000–2500 m in the upper Río Marañón Valley, in the Cordillera Occidental in the vicinity of Cajamarca and southward, in the vicinity of Chachapoyas in the Cordillera Central, and in the mountains south and west of Loja in Ecuador. Natural vegetation consists of trees such as *Jacaranda acutifolia*, *Caesalpinia tinctoria*, and various *Acacia* and *Mimosa*. Generally, these areas are heavily cultivated and have plantings of *Agave americana* and *Eucalyptus globulus*.

Humid Montane Forest.—(Bosque húmedo montano). This is the dominant type of forest on the lower slopes (up to about 2500 m) of the cordilleras Huancabamba, Tabacones, Cóndor, and Colán, where it is continuous to the Cordillera Central. Principal trees include *Berberis*, *Polylepis*, and *Eugenia*. At higher elevations (>3000 m) in the Cordillera Occidental, this vegetation is reduced to few trees, bushes (*Baccharis*) and bunch grasses. Much of this forest has been cleared and cultivated; at higher elevations *Eucalyptus* has been planted.

Very humid montane forest.—(Bosque muy húmedo montano). This is the “ceja de la montaña” or “cloud forest” characteristic mostly of windward slopes at elevations of 2500–3000 m and receiving 1000–2000 mm of rainfall annually. This forest exists on the higher ridges of the cordilleras Huancabamba, Tabacones, Cóndor, and Colán, as well as on the slopes (especially eastern) of the Cordillera Central in Peru and the Cordillera Occidental in Ecuador. A variety of trees, often stunted and covered with lichens and mosses, includes *Polylepis* and *Podocarpus*. Also characteristic are bushes (*Baccharis*) and the spiny bamboo (*Chusquea spicata*). Arboreal bromeliads are locally abundant.

Humid subtropical forest.—(Bosque húmedo y muy húmedo subtropical). Covering the lower (500–1900 m) eastern slopes of the Cordillera Central and middle Río Mayo Valley, and lower slopes of the Cordillera Oriental in Ecuador, this type of forest develops in areas receiving as little as 1000 mm of rainfall annually to others that receive rainfall in excess of 3000 mm. The forest consists of a variety of moderate to large trees including *Juglans neotropica*, *Cedrela fissipes*, *Tabebuia*, and genera common in the Amazonian lowlands—*Brosimum*, *Cordia*, *Inga*, *Piper*, *Swietenia*. In some areas, the forest has been cleared for citrus and coffee plantations.

Subtropical pluvial forest.—(Bosque pluvial subtropical). In northern Peru, this type of forest is known only on the highest ridges of the Cordillera Central east of the Río Mayo Valley, where rainfall is expected to be in excess of 4000 mm annually. This type of forest consists of stunted trees with emergent palms, such as *Euterpe*.

Humid tropical forest.—(Bosque húmedo tropical). This is the Amazonian rainforest, which receives rainfall in excess of 2000 mm annually and has a great richness of tree species. The trees form a continuous, or nearly so, canopy 30–40 m above the ground, but there are canopy emergents, such as species of *Cedrela*, *Ceiba*, and *Ficus*. This diverse forest contains many kinds of palms (e.g., *Bactris*, *Iriartea*, *Scheelea*), but under certain edaphic and hydrological conditions, the forest is clearly dominated by one species of palm, *Mauritia reflexa*.

Other formations.—Local climatic and edaphic conditions may result in different local vegetation formations. For example, the Abra de Zamora at 2800 m in the Cordil-

lera Oriental of Ecuador is windswept and has vegetation consisting of thick growths of low bushes supporting mosses and large bromeliads. Although Tosi (1960) mapped the highest reaches of the Cordillera Colán as very humid montane forest, data on a field tag of an *Eleutherodactylus* collected by Thomas S. Schulenberg at 3300 m in that cordillera noted “in a grassy bog above treeline.” In the poorly explored Cordillera del Cóndor, the flat-topped sandstone mountains at 2000–2300 m are mostly are covered by sclerophyllous shrublands—shrubs and small trees 2–5 m high; according to Foster and Beltran (1997), these shrublands are composed mostly of species of *Ilex*, *Weinmannia*, *Clusia*, and *Persea*.

GENERA OF ELEUTHERODACTYLIINE FROGS

Four genera within the tribe Eleutherodactylini, as defined by Lynch (1971) occur in the Andes of northern Peru. Only species in the genus *Eleutherodactylus* are treated herein. However, we provide brief diagnoses of external features of all four genera presently recognized in the Andes of northern Peru, so that specimens can be allocated to the proper genus. There is no substantial evidence that any of the genera are monophyletic, and *Eleutherodactylus* may be paraphyletic with respect to the other genera. For example, Lynch (1986) questioned the allocation of species to *Phyllonastes* or *Phrynopus*, and Harvey and Keck (1995) noted the occurrence of “diagnostic” characters of *Ischnocnema* in some species of *Eleutherodactylus*.

Eleutherodactylus Duméril and Bibron, 1841

Diagnosis.—Terrestrial or arboreal frogs characterized by (1) skin on venter smooth or areolate; (2) relative lengths of Fingers I and II variable; (3) relative lengths of Toes III and V variable; (4) digits bearing terminal discs and pads; (5) tips of digits rounded, elliptical, or truncate; (6) tarsal tubercle present or absent; (7) palmar and subarticular tubercles not greatly enlarged; (8) adult size 10–120 mm SVL.

Content.—About 600 species in five subgenera, only one of which (*Eleutherodactylus*) includes the 45 species known from the Andes of northern Ecuador.

Distribution.—Tropical and subtropical America (exclusive of arid regions), through the West Indies and into southwestern United States.

Remarks.—The 45 species known from the Andes of northern Peru are members of four species groups, which are defined in the following Accounts of Species.

Ischnocnema Reinhardt and Lütken, 1862

Diagnosis.—Terrestrial frogs characterized by (1) skin on venter smooth; (2) Finger I > II; (3) Toe V > III; (4) digits bearing small terminal discs; pads present or absent; (5) tips of digits rounded; (6) tarsal tubercle absent; (7) pal-

mar and subarticular tubercles greatly enlarged; (8) adult size 30–55 mm SVL.

Content.—Five species, of which only *Ischnocnema saxatilis* and *I. simmonsii* are in the Andes of northern Ecuador (Duellman, 1990b; Lynch, 1974a).

Distribution.—Upper Amazon Basin, Andean slopes in southern Ecuador, northern Peru, and Bolivia.

Remarks.—Harvey and Keck (1995) questioned the validity of *Ischnocnema*.¹

Phrynopus Peters, 1874

Diagnosis.—Terrestrial frogs characterized by (1) skin on venter smooth or areolate; (2) relative lengths of Fingers I and II variable; (3) Toe III longer than, or equal in length to, Toe V; (4) digits not bearing terminal discs or pads; (5) tips of digits rounded; (6) tarsal tubercle absent; (7) palmar and subarticular tubercles not greatly enlarged; (8) adult size 18–45 mm SVL.

Content.—More than 20 species, of which three have been reported from the Andes of northern Peru; descriptions of three others are being written (Duellman, in prep.).

Distribution.—Humid habitats at moderate to high elevations in the Andes from Colombia to Bolivia. In the Andes of northern Peru, *Phrynopus nebulanastes* and *P. parkeri* are endemic to the Cordillera de Huancabamba, and *P. simonsii* is widespread in the northern part of the Cordillera Occidental (Cannatella, 1984; Lynch, 1975a); one of the undescribed species is from the northern part of the Cordillera Central, and two are from the Cordillera Occidental.

¹It is doubtful that the Amazonian *Ischnocnema quixensis* and the three Andean species are related to the type species, *I. verrucosus*, in southeastern Brazil. If that should be shown to be true, *Oreobates* Jiménez de la Espada, 1872 (type species by monotypy *O. quixensis*) is an available generic name.

Remarks.—In reviewing the osteology of *Phrynopis*, *Phyllonastes*, and other genera, Lynch (1986) noted that the *Phrynopis peruvianus* group and *Phyllonastes* may be related.

Phyllonastes Heyer, 1977

Diagnosis.—Terrestrial frogs characterized by (1) skin on venter smooth; (2) Finger I shorter than or equal in length to Finger II; (3) Toe III shorter than Toe V; (4) digits not bearing terminal discs or pads; (5) tips of at least Toes III and IV pointed; (6) prominent tarsal tubercle present; (7) palmar and subarticular tubercles not greatly enlarged; (8) adult size 13–20 mm SVL.

SUMMARY OF TAXONOMIC CHARACTERS

Morphological characters, size, and color pattern of members of this genus in western Ecuador were described in detail and illustrated by Lynch and Duellman (1997). Consequently, we treat the characters rather briefly herein; 22 morphological characters and eight features of color pattern for species of *Eleutherodactylus* in the Andes of northern Peru are tabulated in Tables 1 and 2. As deemed necessary, we attempt to clarify some of these characters below.

Skin texture.—Although statements in the diagnoses and descriptions may suggest that various states are discrete, they are not in many cases. For example, the distinction between the dorsal skin being shagreen with scattered tubercles versus finely tuberculate is not discrete, and certainly different persons may describe the conditions in different ways. The ventral skin commonly has been described as granular; we use the term areolate. In contrast, fine granules on the dorsum give the skin a finely textured appearance that we term shagreen. If the granules are large and subconical or conical, we define the texture as tuberculate.

Dorsolateral folds on the body are evident in seven species of the *Eleutherodactylus conspicillatus* Group (*E. avicuporum*, *citriogaster*, *condor*, *karcharias*, *lymani*, and *peruvianus*) and in *E. araiodactylus*. Of these, *E. avicuporum* and *E. karcharias* also have interrupted, longitudinal folds on the flanks. In the Andes of northern Peru, *E. avicuporum* is unique in having a dermal interocular ridge. This feature also is present in another member of the *Eleutherodactylus conspicillatus* Group, *E. skydmainos* (Flores and Rodríguez, 1997) and in some other species of the (e.g., *E. quinquagesimus* [Lynch and Duellman, 1997]).

Tubercles.—The most noticeable and taxonomically useful tubercles are those on the upper eyelid and heels. We diverge from Lynch and Duellman (1997) in the recognition of eyelid tubercles; they used the term only for the presence of enlarged conical or subconical tubercles on the

Content.—Four species, two of which occur in the Andes of northern Peru.

Distribution.—*Phyllonastes myrmecoides* inhabits the upper Amazon Basin, whereas three montane species have been reported from only a few localities—*P. heyeri* from Alamor, Ecuador, and the Cordillera de Huancabamba in Peru (Lynch, 1986)²; *P. lochites* from the Cordillera del Condor in Ecuador (Lynch, 1976); and *P. lynchi* from the northern part of the Cordillera Central in Peru (Duellman, 1991b).

Remarks.—See Remarks under *Phrynopis*.

eyelid. No species in the Andes of northern Peru possess such distinctive tubercles, but many species have a few pungent tubercles on the upper eyelid. If a tubercle is present on the heel, it usually is small, but four species (*Eleutherodactylus galdi*, *lanthanites*, *muscosus*, and *quaquaversus*) have large, conical tubercles on the heel.

Tuberculation on the tarsus is highly variable. Tubercles are absent in several species (e.g., *Eleutherodactylus citriogaster*, *colodactylus*, *proserpens*, and *ruficulis*). Tubercles are present on the outer surface of the tarsus in many species (e.g., *E. anemerus*, *bearsei*, *schultei*, and *versicolor*); the outer tarsal tubercles are noticeably conical in *E. galdi*. The inner edge of the tarsus may be unadorned (e.g., *E. condor*, *infraguttatus*, *percnopterus*, and *phoxocephalus*), bear a low, elliptical tubercle distally (e.g., *E. ceuthospilus*, *cuneirostris*, *nephophilus*, and *petrobardus*), or have a low fold distally (e.g., *E. atrabracus*, *avicuporum*, *melanogaster*, and *rhodoplichus*).

A row of tubercles may be present on the ventrolateral surface of the forearm. These ulnar tubercles are absent in several species (e.g., *Eleutherodactylus bromeliaceus*, *incomptus*, *lymani*, and *phoxocephalus*). The tubercles are especially prominent in *E. cryptomelas* and *E. infraguttatus*, conical in *E. galdi*, and coalesced to form a short fold in *E. pinguis*.

Two species (*Eleutherodactylus anemerus* and *E. proserpens*) have a noticeable tubercle (papilla) on the tip of the snout, and *E. phoxocephalus* has a low vertical keel on the snout. *Eleutherodactylus karcharias* is unique in having a finlike middorsal tubercle on the body.

Tympanum.—As emphasized by Lynch and Duellman (1997:28): “The terms ‘tympanum’ and ‘external ear’ have been used to identify a combination of characters rather than a single character. The ‘tympanum’ is a combination

²A specimen (LSUMZ 39364) from the Cordillera Cólan extends the known range of this species eastward into Departamento Amazonas, Peru.

Table 1. States of structural characters in *Elicuthierodactylus* from the Andes of northern Peru. Snout: Acutely rd. = acutely rounded, Blunt. rd. = bluntly rounded, Incl. pv. = inclined posteroventrally, Subacum. = subacuminate. Tympanum condition: A = membrane and annulus prominent, B = membrane absent but most of circumference of annulus visible through skin, C = membrane absent and annulus evident only ventrally, D = membrane and annulus absent. Digital fringes: F = fingers, T = toes. Toe condition: A = Toe III = Toe V, B = Toe V > Toe III but not extending to penultimate subarticular tubercle of Toe IV, C = Toe V >> Toe III.

Species	Skin on venter	Skin on dorsum	Dorsolateral folds	Snout dorsal	Snout Profile	Tympanum Condition	Eyelid Width	Eyelid Tubercles	Disks on fingers	Digital Fringes	Fingers I & II	Heel Tubercles	Toe Condition
<i>acuminatus</i>	Areolate	Smooth	Absent	Acuminate	Incl. pv.	C	<< IOD	Absent	Elliptical	—	I < II	Absent	C
<i>anemerus</i> ¹	Areolate	Tuberculate	Absent	Acuminate ²	Truncate	A	≤ IOD	Absent	Truncate	F, T	I < II	Absent	C
<i>ariodactylus</i>	Smooth	Smooth	Present	Rounded	Rounded	A	< IOD	Absent	Small	F, T	I = II	Absent	A
<i>aridionychius</i>	Areolate	Smooth	Absent	Rounded	Rounded	C	≤ IOD	Absent	Rounded	F, T	I < II	Absent	C
<i>atrabracus</i> ¹	Areolate	Shagreen	Absent	Blunt. rd.	Blunt. rd.	A	≤ IOD	Absent	Small	F, T	I < II	Absent	B
<i>avucaporum</i> ³	Areolate	Smooth	Present ⁴	Blunt. rd.	Rounded	A	≤ IOD	Present	Truncate	F	I > II	Absent	B ⁵
<i>basei</i>	Areolate	Tuberculate	Absent	Rounded	Rounded	A	≤ IOD	Absent	Truncate	F, T	I < II	Absent	C
<i>bromeliaceus</i>	Areolate	Smooth	Absent	Subacum.	Acutely rd.	A	≤ IOD	Present	Elliptical	F, T	I < II	Small	C
<i>cujamarcensis</i>	Areolate	Shagreen	Absent	Rounded	Rounded	A	≤ IOD	Present	Rounded	T	I < II	Absent	C
<i>cutiophilus</i>	Areolate	Shagreen	Absent	Acutely rd.	Acutely rd.	A	≤ IOD	Present	Rounded	F, T	I < II	Absent	C
<i>citriogaster</i>	Smooth	Smooth	Present	Subacum.	Rounded	A	≤ IOD	Absent	Rounded	—	I > II	Absent	B
<i>colodactylus</i> ⁶	Areolate	Areolate	Absent	Subacum.	Rounded	A	≤ IOD	Present	Elliptical	F, T	I < II	Small	C
<i>condor</i>	Smooth	Shagreen	Present	Subacum.	Rounded	A	> IOD	Absent	Elliptical	T	I > II	Absent	B
<i>cryptomelas</i>	Areolate	Shagreen	Absent	Subacum.	Acutely rd.	A	≤ IOD	Present	Truncate	F, T	I < II	Small	C
<i>cuneirostris</i> ⁷	Smooth	Smooth	Absent	Rounded	Acutely rd.	A	≤ IOD	Present	Truncate	—	I = II	Absent	B
<i>exoristus</i>	Areolate	Truncate	Absent	Acutely rd.	Blunt. rd.	A	< IOD	Present	Elliptical	—	I < II	Absent	C
<i>galdi</i>	Smooth	Areolate	Absent	Acuminate	Truncate	A	< IOD	Present	Truncate	F, T	I < II	Conical	C
<i>incomptus</i> ¹	Areolate	Smooth	Absent	Acutely rd	Rounded	A	≤ IOD	Absent	Truncate	T	I < II	Absent	C
<i>infragitatus</i>	Areolate	Smooth	Absent	Rounded	Rounded	A	≤ IOD	Present	Elliptical	F, T	I < II	Absent	C
<i>karcharias</i> ^{7,8}	Areolate	Shagreen	Present ⁴	Rounded	Rounded	A	> IOD	Absent	Truncate	F, T	I = II	Absent	B ⁵
<i>lanthanites</i>	Smooth	Tuberculate	Present	Acuminate	Rounded	A	≤ IOD	Absent	Truncate	—	I > II	Small	B
<i>lirellus</i>	Areolate	Areolate	Absent	Subacum.	Rounded	D	≤ IOD	Present	Elliptical	F, T	I < II	Small	C
<i>lymani</i>	Areolate	Shagreen	Present	Subacum.	Rounded	B	≤ IOD	Absent	Rounded	F, T	I > II	Absent	B
<i>melanogaster</i> ^{1,6}	Areolate	Areolate	Absent	Rounded	Rounded	A	≤ IOD	Present	Small	—	I < II	Absent	B
<i>metabates</i>	Smooth	Tuberculate	Absent	Rounded	Rounded	A	≤ IOD	Present	Truncate	F, T	I > II	Absent	B ⁵
<i>muscosus</i> ⁷	Areolate	Smooth	Absent	Blunt. rd.	Blunt. rd.	A	≤ IOD	Present	Truncate	F, T	I > II	Conical	C
<i>nephophilus</i>	Areolate	Smooth	Absent	Rounded	Rounded	A	≤ IOD	Present	Truncate	F, T	I < II	Absent	C
<i>ockendeni</i>	Shagreen	Areolate	Absent	Subacum.	Rounded	A	≤ IOD	Present	Elliptical	F, T	I < II	Small	C
<i>pataikos</i> ^{1,7}	Areolate	Smooth	Absent	Rounded	Rounded	B	≤ IOD	Absent	Small	—	I < II	Rounded	C
<i>pecki</i>	Areolate	Smooth	Absent	Subacum.	Rounded	A	≤ IOD	Present	Small	F, T	I < II	Absent	B
<i>percnopteris</i> ¹	Areolate	Tubercular	Absent	Subacum.	Rounded	A	≤ IOD	Abs./ pres.	Rounded	—	I < II	Small	C
<i>peruvianus</i>	Smooth	Shagreen	Present	Subacum.	Rounded	A	≤ IOD	Present	Truncate	—	I < II	Absent	C
<i>petrobardus</i>	Areolate	Pustular	Absent	Subacum.	Rounded	A	> IOD	Absent	Elliptical	F, T	I > II	Absent	B
<i>phoxocephalus</i> ⁹	Areolate	Shagreen	Absent	Rounded	Subacum.	A	≤ IOD	Absent	Elliptical	F, T	I < II	Small	C
<i>pinguis</i> ⁷	Areolate	Areolate	Absent	Acutely rd.	Blunt. rd.	A	≤ IOD	Absent	Small	T	I < II	Absent	B
<i>proserpens</i>	Areolate	Areolate	Absent	Subacum. ²	Rounded	A	< IOD	Present	Rounded	F, T	I < II	Absent	C ⁵
<i>quaquaversus</i>	Shagreen	Areolate	Absent	Subacum.	Subacum.	C	< IOD	Present	Elliptical	F, T	I < II	Conical	C
<i>rhodoptichus</i> ¹	Areolate	Shagreen	Absent	Subacum.	Subacum.	A	≤ IOD	Present	Elliptical	F, T	I < II	Small	C
<i>rhodostichus</i>	Areolate	Shagreen	Absent	Subacum.	Subacum.	A	≤ IOD	Present	Elliptical	F, T	I < II	Absent	C
<i>rufioculis</i> ⁶	Areolate	Smooth	Absent	Acuminate	Incl. pv.	A	≤ IOD	Absent	Small	T	I < II	Absent	C
<i>schultei</i>	Areolate	Shagreen	Absent	Rounded	Rounded	B	≤ IOD	Absent	Elliptical	T	I < II	Absent	C
<i>serendipitus</i>	Areolate	Shagreen	Absent	Subacum.	Incl. pv.	A	≤ IOD	Present	Rounded	F, T	I < II	Small	B
<i>sternophilax</i>	Areolate	Tuberculate	Absent	Subacum.	Blunt. rd.	A	≤ IOD	Absent	Elliptical	—	I < II	Absent	C
<i>versicolor</i> ⁶	Areolate	Shagreen	Absent	Subacum.	Acutely rd.	A	≤ IOD	Absent	Truncate	F, T	I < II	Absent	C
<i>witensi</i>	Areolate	Smooth	Absent	Acutely rd.	Rounded	C	≤ IOD	Abs./ pres.	Elliptical	F, T	I < II	Absent	C

¹Vomerine odontophores absent

²Tubercle on tip of snout

³Interocular dermal fold

⁴Also lateral fold on body

⁵Toes webbed basally

⁶Vocal slits absent

⁷Condition of vocal slits unknown

⁸Finlike middorsal tubercle

⁹Vertical keel on snout

of (1) a differentiated tympanic membrane and (2) a tympanic annulus." They recognized four states of tympanic annuli and membranes. In most *Eleutherodactylus* in the Andes of northern Peru, a prominent tympanic membrane and annulus are present. The membrane is not differentiated but most of the annulus is visible beneath the skin in *E. melanogaster*, *pataikos*, and *rufioculis*, whereas only the ventral part of the annulus is visible below the skin in *E. acuminatus*, *ardalonychus*, *quaquaversus*, and *wiensi*. There is no external evidence of an ear in *E. colodactylus* and *E. lirellus*.

Fingers and toes.—In all members of the *Eleutherodactylus orestes* and *unistrigatus* groups in the Andes of northern Peru, the first finger (thumb) is shorter than the second. The first finger is longer than the second in most species in the *Eleutherodactylus conspicillatus* Group, but the two digits are about equal in length in *E. cuneirostris* and *E. karcharias*, as well as in *E. araiodactylus* in the *Eleutherodactylus nigrovittatus* Group. As shown by Lynch and Duellman (1979), the relative lengths of Toes III–IV is an important taxonomic character. Except for *E. araiodactylus*, in which Toes III and V are of equal length, Toe V is longer than Toe III in all species in the region. In members of the *Eleutherodactylus conspicillatus* and *orestes* groups, Toe V is only slightly longer than Toe III, and neither toe extends to the level of the distal subarticular tubercle on Toe IV. In species in the *Eleutherodactylus unistrigatus* Group, Toe V is noticeably longer than Toe III and extends to the middle or distal border of the distal subarticular tubercle of Toe IV.

With the exception of species in the *Eleutherodactylus nigrovittatus* and *orestes* groups, in which the discs on the fingers and toes are barely expanded, the discs on Fingers I and II and all toes are expanded. Their shapes are described arbitrarily as rounded, elliptical (much wider and long), or truncate.

Most species have lateral fringes on the digits. We do not distinguish between fringes (thin) and keels (thick). Webbing between the toes is absent in all species, except three members of the *E. conspicillatus* group (*E. avicuporum*, *karcharias*, and *metabates*) in which basal webbing is present.

Coloration.—The dorsal coloration can be used readily for identification of most species of frogs—not so for most species of *Eleutherodactylus*, in which distinctive coloration may be present only in the groin or on the anterior and/or posterior surfaces of the thighs (Table 2). In northern Peru, only two species are easily identified by their dorsal coloration—uniform green (in life) in *E. acuminatus* and uniform orange-red (in life) in *E. anemerus*. In preservative, the dorsal coloration of most species is varying shades of tan, brown, or gray, usually with darker markings. These may consist of distinct spots (e.g., *E. cuneirostris*), chev-

rons (V-shaped marks with the apex anterior) (e.g., *E. lanthanites* and *E. lymani*), or a W-, X-, or H-shaped mark in the scapular region (e.g., *E. ardalonychus*, *exoristus*, and *sternothylax*). Other dorsal patterns include dark longitudinal streaks or dashes (e.g., *E. ceuthospilus*, *galdi*, and *percnopterus*), a large middorsal blotch (e.g., some *E. proserpens*), and pale vermiculations (*E. muscosus*). Identification is confused further by pattern polymorphism in several species. For example, some individuals of *E. colodactylus*, *proserpens*, *rhodoplichus*, and *sternothylax* have pale dorsolateral stripes, whereas some individuals of *E. schultei* and *E. wiensi* have dark dorsolateral stripes. Some specimens of *E. barsei* and *E. petrobardus* have pale spots on the dorsum.

Facial markings usually consist of dark labial bars, but these are absent in some species (Table 2). *Eleutherodactylus cuneirostris* and some specimens of *E. peruvianus* have a pale labial stripe. A dark canthal stripe is evident in most species and is especially notable in *E. acuminatus* and *E. galdi*. The canthal stripe is incorporated into a dark face mask encompassing the loreal region in *E. peruvianus*.

The coloration on the venter in most species is cream (with or without dark flecks) to brown. However, distinctive coloration is present in a few species—bright yellow (in life) in *Eleutherodactylus citriogaster*, uniform black in *E. melanogaster*, black on the ventral surfaces of the hind limbs in *E. atrabracus*, and brown or black marbling or reticulation (e.g., *E. ardalonychus*, *infraguttatus*, *muscosus*, and *versicolor*).

Whereas the groin is colored like the flanks in most *Eleutherodactylus*, distinctive markings are present in some species. Commonly these are pale spots, which are white, yellow, or red in life; such spots are characteristic of most species in the *Eleutherodactylus orestes* Group, but also exist in *E. cajamarcensis*, *condor*, *lirellus*, *muscosus*, and *rufioculis*. The groin has dark reticulation in *E. phoxocephalus* and is black in *E. cryptomelas*.

In preserved specimens of *Eleutherodactylus*, the posterior surfaces of the thighs usually are varying shades of tan to brown, with or without pale flecks or spots that are cream to red in life (Table 2). Notable exceptions are dark reticulations (*E. phoxocephalus*, *quaquaversus*, and *E. rhodoplichus*), pale mottling (*E. ardalonychus*, *citriogaster*, and *infraguttatus*), or black with white spots (*E. lymani*).

Sizes and proportions.—The sizes of adults of *Eleutherodactylus* are highly variable. With the exception of some species in the *Eleutherodactylus conspicillatus* Group, most species in the Andes of northern Peru have SVLs of less than 35 mm (Table 3). Considerable sexual dimorphism in size is evident in most species of *Eleutherodactylus*, in which females usually are at least one third larger than males. In the species in the Andes of northern Peru, SVLs

Table 2. Coloration of *Elautherodactylus* from the Andes of northern Peru. Coloration is that of preserved specimens, unless noted otherwise.

Species	Interorbital bar	Labial bars	Limb bars	Dorsum of body	Flanks	Groin	Posterior thighs	Throat and belly	Other markings
<i>E. acuminatus</i>	Faint	No	No	Uniform pale	Uniform pale	Unmarked	Uniform pale	Uniform pale	Black canthal stripe
<i>E. anemerus</i>	No	No	No	Uniform pale	Uniform pale	Unmarked	Uniform pale	Pale with black flecks	Dorsum orange-red in life
<i>E. araiodactylus</i>	Yes	No	Faint	Pale with dark median mark	Dark brown	Unmarked	Uniform tan	Uniform tan	Middorsal pale stripe
<i>E. ardalonychus</i>	Yes	Diagonal	Diagonal	Scapular W; sacral chevron	Diagonal bars	Unmarked	Cream mottling	Brown reticulations	Dark edges on digital discs
<i>E. atrinetractus</i>	No	No	No	Uniform brown	Uniform brown	Large pale spot	Uniform brown	Brown reticulations	Black on venter of hind limbs
<i>E. aticuporum</i>	Faint	Faint	Faint	Medial dark spot; pale chevron	Uniform tan	Unmarked	Small pale spots	Brown reticulation	None
<i>E. bearsei</i>	Yes	Yes	Yes	Scapular W; dark blotches	Brown with cream flecks	Unmarked	Uniform brown	Brown with cream flecks	Large pale spots dorsally in some
<i>E. bromeliacicus</i>	Yes	Yes	Spots	Few dark spots or chevron	Uniform tan	Unmarked	Brown with cream spots	Cream (with brown flecks in ♀♀)	Dorsum green in life
<i>E. cojanmarcensis</i>	Yes	Faint	Faint	Small dark blotches	Tan with dark spots	Black with white spots	Black with white spots	Cream with dark spots	Groin and thighs red in life
<i>E. ceuthospilus</i>	Yes	Yes	Yes/no	Uniform tan, or with dark dashes	Uniform tan	Pale spots	Tan with pale spots	Pale with brown flecks	Pale spots yellow in life
<i>E. citriogaster</i>	Yes	Yes	Yes	Brown chevrons	Diagonal bars	Unmarked	Cream mottling	Dark flecks on throat	Venter bright yellow in life
<i>E. colodactylus</i>	Pale, no	No	No	Brown or gray	Brown or gray	Unmarked	Uniform brown	Brown	Pale dorsolateral stripe in some
<i>E. condor</i>	Yes	Yes	Yes	Dark chevrons	Diagonal bars	Pale spots	Cream spots	Brown throat; brown mottling on belly	None
<i>E. cryptomelas</i>	Yes	Yes	Diagonal	Scapular W; sacral chevron	Cream	Black	Black	Cream with brown reticulation	Black in axilla
<i>E. cuietirostris</i>	No	No	Yes	Many dark spots	Uniform tan	Unmarked	Uniform brown	Cream with faint brown reticulation	Pale labial stripe
<i>E. exoristus</i>	Yes	Yes	Yes	Scapular W or H; sacral chevrons	Diagonal bars	Unmarked	Brown with cream flecks	Tan with brown flecks	Diffuse canthal stripe
<i>E. galdi</i>	Yes	No	Narrow	Cream with dark dashes	Uniform cream	Unmarked	Uniform cream	Uniform cream	Dorsum green in life
<i>E. incomptus</i>	Yes	Yes	Yes	Scapular W; sacral chevron	One diagonal streak or not	Unmarked	Uniform brown	Uniform brown	None
<i>E. infraquattatus</i>	Yes	No	Yes	Scapular spots	Tan with brown spots posteriorly	Unmarked	Brown with cream mottling	Cream with brown marbling	Anterior thigh red in life
<i>E. karcharias</i>	Yes	Yes	Diagonal	Scapular W; two chevrons	Diagonal bar	Unmarked	Brown with cream spots	Cream with brown flecks	None
<i>E. lanthanites</i>	Yes	Yes, no	Yes	Dark chevrons	Diagonal bars	Unmarked	Brown with small pale spots	Belly white with gray flecks	White stripe on gray throat
<i>E. lirellus</i>	Faint, no	Yes	Yes	Broad scapular H	Faint diagonal bars	Pale spot	Uniform brown	Cream with black flecks	Groin spot yellow in life
<i>E. lymani</i>	Yes	Yes	Yes	Dark chevrons or spots	Dark spots	Unmarked	Black with white spots	White with gray flecks on throat	None

Table 2 continued

Species	Interorbital bar	Labial bars	Limb bars	Dorsum of body	Flanks	Groin	Posterior thighs	Throat and belly	Other markings
<i>E. melanogaster</i>	No	No	No	Uniform black	Uniform black	Pale spots	Uniform black	Uniform black	Spots in groin yellow in life None
<i>E. metaltatis</i>	Faint	Faint	Faint	X-shaped mark and/or chevrons	Diagonal bars	Unmarked	Brown with cream flecks	Cream; brown flecks on throat	None
<i>E. muscosus</i>	Faint	Yes	Yes	Dark with white vermiculations	Brown with white spots	Pale spots	Brown with cream spots	Cream with brown reticulation	Pale spots under hind limbs
<i>E. nephophilus</i>	Yes, no	Yes	Diagonal	Dark blotches or streaks	Diagonal bars or reticulation	Unmarked	Brown with cream bars	Heavily flecked with brown	Iris red in life
<i>E. ockendeni</i>	Narrow or faint	Yes	Diagonal	Scapular W or chevrons	Uniform tan	Unmarked	Uniform brown	White with brown spots	Venter unspotted in some
<i>E. pataikos</i>	No	No	No	Uniform brown	Uniform brown	Unmarked	Uniform brown	Uniform tan	Cream canthal stripe in life
<i>E. pecki</i>	Yes, no	Yes	Yes	Dark spots or streaks	Uniform brown	Unmarked	Uniform brown	Heavily flecked with brown	None
<i>E. perenopteris</i>	Yes	Yes	Diagonal	Scapular black spots or streaks	Uniform pale brown	Unmarked	Uniform pale brown	Tan with small black flecks	None
<i>E. peruvianus</i>	Yes, no	Yes	Diagonal	Dark chevrons	Diagonal bars	Unmarked	Brown with pale flecks	Cream with brown flecks	Some unpatterned dorsally
<i>E. petrobardus</i>	Yes	Yes	Diagonal	Irregular dark streaks	Diagonal bars	Unmarked	Brown with cream spots	White with black flecks	White spots on dorsum in some
<i>E. phoxcephalus</i>	Yes, no	No	Faint, no	None or irregular dark marks	None or dark reticulation	Dark reticulation	Dark reticulation	Uniform cream	Pale spots on dorsum in some
<i>E. pinguis</i>	Faint	No	Diagonal	Small dark flecks	None	Large pale spot	Cream with brown marks	Uniform cream	Pale spots on dorsum in some
<i>E. proserpens</i>	Yes	No	Yes	X or large blotch	Uniform tan	Unmarked	Uniform cream or brown	Uniform brown	None
<i>E. quaquaversus</i>	Yes	No	Diagonal	Dark spots or chevrons	Uniform tan	Unmarked	Brown reticulations	White	Dorsolateral stripes in some
<i>E. rhodoplichus</i>	Triangle	No	Yes, no	Small irregular dark marks	Diagonal bars or reticulation	Unmarked	Dark reticulation	Cream with dark flecks	Ventral spots in some
<i>E. rhodostichus</i>	Yes	Faint	Yes	Scapular and sacral streaks	Small dark spots	Unmarked	Uniform tan	Tan with flecks laterally	Pale dorsolateral stripe in some
<i>E. ruficollis</i>	Yes	No	Faint	Small scapular dark spots	Cream spots	Cream spots	Brown with cream flecks	Heavily flecked with brown	Linear marks red in life
<i>E. schultzei</i>	Yes, no	No	Faint, no	Uniform pale	Pale with dark streaks	Unmarked	Uniform pale	White	Iris red in life
<i>E. serondipitus</i>	Yes	Yes	Yes	Scapular marks; sacral chevron	Pale brown	Unmarked	Uniform brown	Cream with brown flecks	Dark dorsolateral stripe in some
<i>E. sternothulax</i>	Triangle	Yes	Diagonal	Scapular X, H, or W; chevrons	Diagonal streaks	Unmarked	Uniform brown	Cream with brown flecks	None
<i>E. versicolor</i>	Yes	Yes	Yes	Dark blotches	Diagonal or vertical bars	Unmarked	Brown with cream flecks	Brown with black reticulation	Pale dorsolateral stripe in some
<i>E. wicensi</i>	Yes	Yes	Yes	Dark spots	Cream with dark mottling	Unmarked	Brown with cream spots	Irregular brown spots	White spots on flanks in some
									Dark dorsolateral stripe in some

Table 3. Body sizes (SVL in mm) of *Eleutherodactylus* in the Andes of northern Peru. Values include range (mean, sample size), SD = sexual dimorphism. Unless noted otherwise, measurements are for Peruvian specimens only.

Species	Males	Females	SD
<i>E. acuminatus</i>	21.3–21.5 (21.4, 2)	24.3	1.14
<i>E. anemerus</i>	20.4	—	—
<i>E. araiodactylus</i>	—	24.5	—
<i>E. ardalonychus</i>	19.7–21.9 (20.8, 2)	27.4	1.32
<i>E. atrabracus</i>	18.9	22.7	1.20
<i>E. avicuporum</i>	25.2	31.0–34.3 (32.4, 6)	1.29
<i>E. bearsei</i>	22.7–25.5 (24.0, 3)	38.0–38.8 (38.4, 2)	1.60
<i>E. bromeliaceus</i> ¹	16.7–23.2 (20.8, 14)	22.9–28.1 (26.5, 5)	1.27
<i>E. cajamarcensis</i>	22.6–25.9 (24.7, 5)	27.0–32.0 (29.2, 14)	1.18
<i>E. ceuthospilus</i>	19.9–25.8 (21.3, 35)	23.5–26.7 (25.2, 8)	1.18
<i>E. citriogaster</i>	31.6–41.3 (37.0, 9)	42.0–51.0 (44.4, 4)	1.20
<i>E. colodactylus</i>	16.8–19.6 (18.3, 19)	19.1–23.2 (21.5, 9)	1.17
<i>E. condor</i> ²	32.1–39.5 (36.5, 9)	52.6–63.2 (58.7, 3)	1.61
<i>E. cryptomelas</i> ³	28.2–30.2 (29.2, 4)	38.6	1.32
<i>E. cuneirostris</i>	—	29.1	—
<i>E. exoristus</i>	15.0–16.9 (16.2, 4)	21.3–23.5 (22.7, 6)	1.40
<i>E. galdi</i> ⁴	17.1–24.8 (21.0, 8)	28.1–34.0 (31.7, 11)	1.51
<i>E. incomptus</i> ⁵	15.6–18.8 (17.5, 10)	23.7–25.9 (24.5, 7)	1.40
<i>E. infraguttatus</i>	15.8	22.9–24.3 (23.6, 3)	1.49
<i>E. karcharias</i>	—	30.4	—
<i>E. lanthanites</i> ⁶	21.7–26.0 (23.5, 20)	27.5–44.8 (36.2, 32)	1.54
<i>E. lirellus</i>	14.1–17.0 (15.3, 13)	19.4–24.0 (21.5, 12)	1.39
<i>E. lymani</i>	39.7–45.3 (41.9, 4)	48.4–66.7 (58.7, 4)	1.40
<i>E. melanogaster</i>	20.6–22.8 (21.9, 3)	24.2–24.7 (24.5, 2)	1.12
<i>E. metabates</i>	29.9–32.2 (31.1, 2)	—	—
<i>E. mucosus</i>	—	29.6–46.1 (37.8, 4)	—
<i>E. nephophilus</i>	—	24.6–34.0 (29.8, 5)	—
<i>E. ockendeni</i> ⁷	16.9–21.2 (19.1, 3)	24.6–31.5 (28.0, 12)	1.47
<i>E. pataikos</i>	—	21.6	—
<i>E. pecki</i> ⁸	15.3–18.7 (17.3, 3)	25.2	1.46
<i>E. percnopterus</i>	21.5–23.2 (22.5, 3)	25.9	1.15
<i>E. peruvianus</i> ⁶	26.1–30.0, 28.1, 8)	36.0–42.5 (39.1, 9)	1.39
<i>E. petrobardus</i>	27.0–30.7 (28.5, 7)	—	—
<i>E. phoxocephalus</i>	22.7–27.8 (26.2, 5)	38.9	1.48
<i>E. pinguis</i>	—	28.4–29.8 (28.9, 3)	—
<i>E. proserpens</i> ⁹	15.2–21.0 (18.6, 11)	20.2–23.5 (22.0, 4)	1.18
<i>E. quaquaversus</i> ¹⁰	19.6–22.5 (20.7, 29)	24.6–31.3 (27.3, 20)	1.32
<i>E. rhodoplichus</i>	21.8–28.9 (25.8, 17)	30.1–34.2 (32.5, 4)	1.26
<i>E. rhodostichus</i>	19.3	—	—
<i>E. rufioculis</i>	18.1	20.6	1.14
<i>E. schultei</i>	23.5–26.5 (25.0, 10)	28.4–34.0 (31.8, 5)	1.27
<i>E. serendipitus</i>	20.4–21.2 (20.8, 2)	—	—
<i>E. sternothylax</i>	18.3–29.1 (24.2, 39)	28.3–36.7 (32.1, 6)	1.33
<i>E. versicolor</i>	21.8–24.7 (23.3, 2)	26.0–27.3 (26.5, 3)	1.14
<i>E. wiensi</i>	27.8–33.0 (30.7, 6)	37.0	1.21

¹Provincia Morona-Santiago, Ecuador (Lynch, 1979)
²Including specimens from Provincia Morona-Santiago, Ecuador (Lynch and Duellman, 1980)
³Provincias Loja and Santiago-Zamora, Ecuador (Lynch, 1979)
⁴Cordillera Oriental, Ecuador, and Cordillera del Cóndor (Lynch and Duellman, 1980)
⁵Provincia Napo, Ecuador (Lynch and Duellman, 1980)
⁶Upper Amazon Basin (Lynch, 1980)
⁷Amazonian Peru (Lynch, 1980)
⁸Including specimens from the Cordillera de Cutucú, Ecuador (Duellman and Lynch, 1988)
⁹Cordillera Oriental, Ecuador (Lynch, 1979)
¹⁰Cordillera Oriental, Ecuador (Lynch and Duellman, 1980)

of females are 1.12–1.61 (\bar{x} = 1.25) greater than those of males.

The three groups of *Eleutherodactylus* in the Andes of northern Peru have distinctly different proportional hind-limb lengths (Fig. 4). In members of the *Eleutherodactylus orestes* Group, the mean tibia/SVL ratio is 37.0–39.6 (\bar{x} = 38.4, n = 4), whereas members of the *Eleutherodactylus conspicillatus* Group have much longer hind limbs; the mean tibia/SVL ratio is 60.4–65.6 (\bar{x} = 62.2, n = 9). Ratios among species in the *Eleutherodactylus unistrigatus* Group are intermediate—43.3–56.0 (\bar{x} = 49.4, n = 31). The lowest ratios (43.3 and 44.1) are for two bromeliad-dwelling species, *E. colodactylus* and *E. proserpens*; elimination of those two species gives a range of 47.5 (*E. phoxocephalus*, also a bromeliad-dweller), to 56.0 (*E. rufioculis* and *E. wiensi*) with a mean of 49.9.

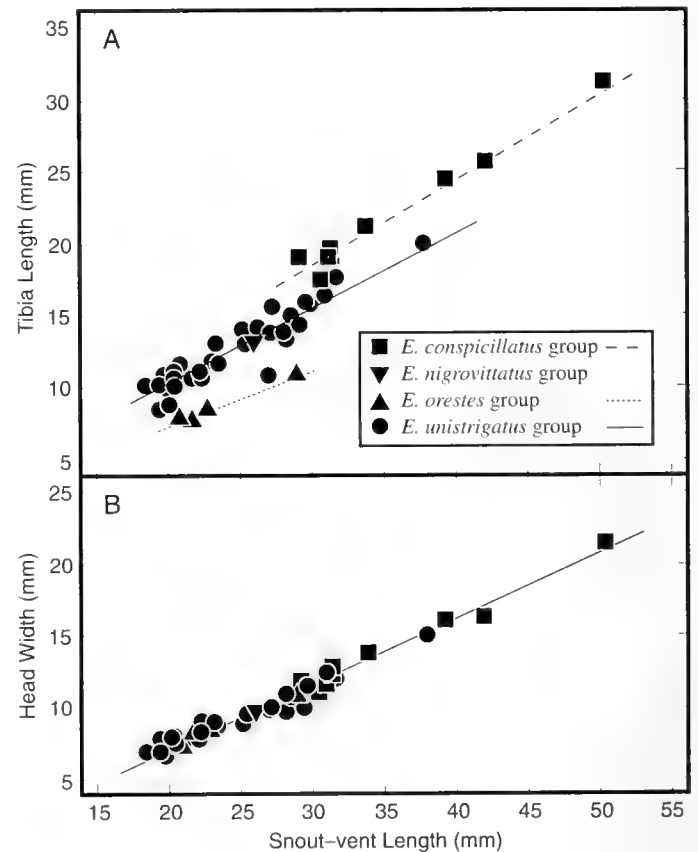

Fig. 4. Correlations of tibia length (A) and head width (B) with snout-vent length in *Eleutherodactylus* in the Andes of northern Peru. Symbols for the species groups are the same in both graphs.

IDENTIFICATION OF SPECIES

KEY TO THE SPECIES

This key emphasizes those external features usually independent of maturity and sex; however, juveniles are always difficult to identify, because the distinctness of the tympanic membrane and annulus increases with age, and many features of color patterns on the venter and concealed surfaces of the limbs develop with age. This key is only a guide; it is necessary to confirm the identifications by referring to the diagnoses and descriptions.

1. Toe V longer than Toe III 2
Toes III and V equal in length *E. araiodactylus*
2. Toe V only slightly longer than Toe III 3
Toe V much longer than Toe III 15
3. Finger I longer than, or equal in length, to Finger II; outer fingers with greatly expanded discs 4
Finger I shorter than Finger II; outer fingers with narrow, rounded discs 12
4. Skin on belly areolate 5
Skin on belly smooth 6
5. Fin-shaped middorsal tubercle present; interocular fold present *E. karcharias*
Fin-shaped middorsal tubercle absent; interocular fold usually present, weak *E. avicuporum*
6. Toes webbed basally *E. metabates*
Toes unwebbed 7
7. Prominent conical tubercle on heel; throat dark with median white stripe *E. lanthanites*
Heel lacking tubercle; no white stripe on throat 8
8. Snout long, wedge shaped; broad, pale labial stripe present; dorsum with many small dark spots
..... *E. cuneirostris*
Snout not wedge-shaped; labial region usually barred; dorsal pattern not consisting of many small dark spots 9
9. Posterior surfaces of thighs dark with pale flecks .. 10
Posterior surfaces of thighs with dark and pale mottling 11
10. Throat dark; belly and ventral surfaces of hind limbs with dark mottling *E. condor*
Throat pale; dark flecks or reticulations on throat and chest *E. peruvianus*
11. Posterior surfaces of thighs black with bold cream mottling; dark marks on margin of lower jaw
..... *E. lymani*
Posterior surfaces of thighs brown with tan mottling; venter pale (yellow in life) with diffuse brown spots on throat *E. citriogaster*
12. Dorsum and venter black *E. melanogaster*
- Dorsum brown; venter variable 13
13. Ventral surfaces of hind limbs black *E. atrabracus*
Ventral surfaces of hind limbs cream or tan 114
14. Large pale spot in groin; posterior surfaces of thighs cream with brown marks *E. pinguis*
No pale spot in groin; posterior surfaces of thighs uniform brown *E. pataikos*
15. Tympanic membrane not differentiated 16
Tympanic membrane distinct with well-defined tympanic annulus 22
16. Tympanic annulus absent 17
Tympanic annulus visible beneath skin or evident only ventrally 18
17. Fingers short, stubby, with round discs; labial and limb bars absent; no pale spot in groin *E. colodactylus*
Fingers long, slender, with elliptical discs; labial and limb bars present; pale spot in groin *E. lirellus*
18. Tubercle present on heel 19
Tubercle absent on heel 20
19. Tubercle on heel large, conical; flanks uniform tan; venter white *E. quaquaversus*
Tubercle on heel small, rounded; flanks cream with dark mottling; venter pale with irregular brown spots *E. wiensi*
20. Snout acuminate; dorsum pale (green in life); only markings are black canthal and supratympanic stripes *E. acuminatus*
Snout rounded; dorsal markings consisting of at least interorbital bar, transverse bars on limbs, and dark markings on body 21
21. Flanks with diagonal dark bars; venter cream with brown reticulations *E. ardalonychus*
Flanks dark with pale spots; venter densely flecked with brown *E. rufiocularis*
22. Tubercle present on heel 23
Tubercle absent on heel 32
23. Tubercle on heel large, conical 24
Tubercle on heel small, not conical 25
24. Snout acuminate in dorsal view; row of conical tubercles on outer edge of tarsus; flanks uniform cream *E. galdi*
Snout bluntly rounded in dorsal view; one or two small tubercles on outer edge of tarsus; flanks brown with white spots *E. muscosus*
25. Upper eyelid lacking tubercles *E. petrobarbus*
Upper eyelid bearing tubercles 26
26. Snout rounded in dorsal view; posterior surfaces of

thighs brown with cream bars *E. nephophilus*
 Snout subacuminate in dorsal view; posterior surfaces
 of thighs not brown with cream bars 27

27. Groin and posterior surfaces of thighs black
 *E. cryptomelas*
 Groin and posterior surfaces of thighs not black 28

28. Flanks pale with darker markings 29
 Flanks uniform tan or brown 30

29. Flanks with diagonal bars or reticulations; posterior
 surfaces of thighs with dark reticulations
 *E. rhodoplichus*
 Flanks with dark streaks; posterior surfaces of thighs
 uniformly pale *E. schultei*

30. Posterior surfaces of thighs brown with cream spots
E. bromeliaceus
 Posterior surfaces of thighs uniform brown 31

31. Dorsal markings consisting of dark scapular W or chev-
 ron; venter white with brown spots *E. ockendeni*
 Dorsal markings consisting of dark spots and streaks;
 venter densely flecked with gray *E. pecki*

32. Prominent tubercle on tip of snout 33
 No tubercle on tip of snout 34

33. Dorsum uniformly pale (orange-red in life)
 *E. anemerus*
 Large middorsal blotch or X-shaped mark, interorbital
 and limb bars present *E. proserpens*

34. Posterior surfaces of thighs brown or black with pale
 markings 35
 Posterior surfaces of thighs uniform tan or brown with
 or without darker markings 39

35. Posterior surfaces of thighs and groin black with white
 spots *E. cajamarcensis*
 Posterior surfaces of thighs brown with cream mark-
 ings; groin unmarked 36

36. Posterior surfaces of thighs brown with cream mot-
 tling; flanks tan with brown spots posteriorly
 *E. infraguttatus*
 Posterior surfaces of thighs brown with cream spots
 or flecks; flanks not so marked 37

37. Flanks uniform tan *E. ceuthospilus*
 Flanks tan or cream with diagonal or vertical dark bars
 38

38. Dorsal markings consisting of scapular H- or W-shaped
 mark and chevrons; venter tan with brown flecks
 *E. exoristus*
 Dorsal markings consisting of dark blotches; venter
 dull white with brown or black reticulations
 *E. versicolor*

39. Posterior surfaces of thighs tan with dark brown re-

ticulations; vertical keel on snout *E. phoxocephalus*
 Posterior surfaces of thighs not so colored; no vertical
 keel on snout 40

40. Flanks uniform tan or brown 41
 Flanks with pale or dark markings 42

41. Venter tan with small black flecks; limb bars diagonal
 *E. percnopterus*
 Venter cream with brown flecks; limb bars transverse
 *E. serendipitus*

42. Flanks brown with cream flecks *E. bearsei*
 Flanks not brown with cream flecks 43

43. Flanks with small dark spots; eyelid tubercles present;
 snout acuminate in dorsal view *E. rhodostichus*
 Flanks not having small dark spots; eyelid tubercles
 absent; snout not acuminate in dorsal view 44

44. Throat and belly uniform brown *E. incomptus*
 Throat and belly cream with brown flecks
 *E. sternothylax*

CLAVE DE LAS ESPECIES

Esta clave pone énfasis en los rasgos externos usualmente independientemente de la madurez y el sexo; sin embargo, los juveniles son siempre difíciles de identificar debido a que la membrana y el anillo timpánicos se hacen más visibles con la edad, y muchos rasgos del patrón de coloración del vientre y superficies ocultas de los miembros se desarrollan con la edad. Esta clave es solamente una guía; es necesario confirmar las identificaciones consultando las diagnósis y descripciones.

1. Dedo V del piemás largo que Dedo III 2
 Dedos III y V del pie iguales en largo *E. araiodactylus*
2. Dedo V del pie solamente un poco más largo que Dedo III 3
 Dedo V del pie mucho más largo que Dedo III 15
3. Dedo I de la mano más largo que, o igual de largo que Dedo II; dedos externos con discos muy dilatados ... 4
 Dedo I de la mano más corta que Dedo II; dedos externos con discos angostos, redondeados 12
4. Piel del vientre areolada 5
 Piel del vientre lisa 6
5. Tubérculo dorso medial en forma de aleta presente; pliegue interocular presente *E. karcharias*
 Tubérculo dorso medial ausente; pliegue interocular usualmente presente, incospicuo *E. avicuporum*
6. Dedos posteriores con palmeadura basal *E. metabates*
 Dedos posteriores sin palmeadura 7
7. Tubérculo cónico prominente en el talón; garganta con raya blanca mediana *E. lanthanites*
 Sin tubérculo en el talón; sin raya blanca en la garanta 8

8. Rostro largo, en forma de cuña; raya labial ancha, pálida presente; dorso con muchas manchas oscuras pequeñas *E. cuneirostris*
Rostro no en forma de cuña; región labial usualmente con barras; patrón dorsal no compuesto de muchas manchas oscuras pequeñas 9
9. Superficies posteriores de los muslos oscuras con puntillos pálidos 10
Superficies posteriores de los muslos con monteado oscuro y pálido 11
10. Garganta oscura; vientre del cuerpo y los miembros posteriores con monteado oscuro *E. condor*
Garganta pálida; puntillos o reticulaciones oscuras en la garganta y el pecho *E. peruvianus*
11. Superficies posteriores de los muslos negras con monteado crema; marcas oscuras en el margen de la mandíbula *E. lymani*
Superficies posteriores de los muslos café oscuro con monteado café pálido; vientre pálido (amarillo en vida) con manchas difusas de café oscuro en la garganta ...
..... *E. citriogaster*
12. Dorso y vientre negro *E. melanogaster*
Dorso café; vientre variable 13
13. Superficie ventral de los miembros posteriores negra *E. atrabracus*
Superficie ventral de los miembros posteriores crema o café claro 14
14. Mancha pálida grande en la ingle; superficies posteriores de los muslos crema con marcas café
..... *E. pinguis*
Sin mancha pálida en la ingle; superficies posteriores de los muslos uniformemente café *E. pataikos*
15. Membrana timpánica no diferenciada 16
Membrana timpánica distintiva con anillo timpánico bien definido 22
16. Anillo timpánico ausente 17
Anillo timpánico visible debajo de la piel o evidente solamente ventralmente 18
17. Dedos de la mano cortos y tiesos, con discos redondos; barras de los labios y miembros ausentes; sin mancha pálida en la ingle *E. colodactylus*
Dedos de la mano largos, delgados, con discos elípticos; barras de los labios y miembros presentes; mancha pálida en la ingle *E. lirellus*
18. Tubérculo presente en el talón 19
Tubérculo ausente en el talón 20
19. Tubérculo en el talón grande, cónico; flancos uniformemente café claro; vientre blanco
..... *E. quaquaversus*
Tubérculo en el talón pequeño, redondeado; flancos crema con monteado oscuro; vientre pálido con manchas café irregulares *E. wiensi*
20. Rostro acuminado; dorso pálido (verde en vida); las únicas marcas son rayas canthales y supratimpánicas *E. acuminatus*
Rostro redondeado; marcas dorsales compuestas al menos de una barra interorbital, barras transversales en los miembros y marcas oscuras en el cuerpo 21
21. Flancos con barras oscuras diagonales; vientre crema con reticulaciones café *E. ardalonychus*
Flancos oscuros con manchas pálidas; vientre densamente con puntillado café *E. ruficulis*
22. Tubérculo presente en el talón 23
Tubérculo ausente en el talón 32
23. Tubérculo en el talón grande, cónico 24
Tubérculo en el talón pequeño, no cónico 25
24. Rostro acuminado en vista dorsal; fila de tubérculos cónicos en el borde externo del tarso; flancos uniformemente crema *E. galdi*
Rostro redondeado sin filo en vista dorsal; uno o dos tubérculos pequeños en el borde externo del tarso; flancos café con manchas blancas *E. muscosus*
25. Párpado superior sin tubérculos *E. petrobardus*
Párpado superior con tubérculos 26
26. Rostro redondeado en vista dorsal; superficies posteriores de los muslos café con barras crema
..... *E. nephophilus*
Rostro subacuminado en vista dorsal; superficies posteriores de los muslos diferente de café con barras crema 27
27. Ingle y superficies posteriores de los muslos color negro *E. cryptomelas*
Ingle y superficies posteriores de los muslos distinto de negro 28
28. Flancos pálidos con marcas más oscuras 29
Flancos uniformemente café claro o café oscuro 30
29. Flancos con barras diagonales o reticulaciones; superficies posteriores de los muslos con reticulaciones oscuras *E. rhodoplichus*
Flancos con rayitos oscuras; superficies posteriores de los muslos uniformemente pálido *E. schultei*
30. Superficies posteriores de los muslos café con manchas cremas *E. bromeliaceus*
Superficies posteriores de los muslos uniformemente café 31
31. Marcas dorsales compuestas de una W en la región escapular o chevrón; vientre blanco con manchas café *E. ockendeni*
Marcas dorsales compuestas de manchas y rayitas oscuras; vientre con puntillado gris densamente
..... *E. pecki*

32. Tubérculo prominente en el extremo del rostro 33
Sin tubérculo en el extremo del rostro 34
33. Dorso uniformemente pálido (naranja-rojo en vida) .
..... *E. anemerus*
Mancha grande mediodorsal o marca en forma de X;
barras interorbital y en los miembros presentes
..... *E. proserpens*
34. Superficies posteriores de los muslos café o negro con
marcas pálidas 35
Superficies posteriores de los muslos uniformemente
café claro o café oscuro con o sin marcas más oscuras
..... 39
35. Superficies posteriores de los muslos y la ingle negras
con manchas blancas *E. cajamarcensis*
Superficies posteriores de los muslos café con marcas
crema; ingle sin marcas 36
36. Superficies posteriores de los muslos café montado
con crema; flancos café claro con manchas café oscuras
posteriores *E. infraguttatus*
Superficies posteriores de los muslos café con manchas
o puntillos crema; flancos con patrón diferente 37
37. Flancos uniformemente café claro *E. ceuthospilus*
Flancos café claro o crema con barras diagonales o
verticales 38
38. Marcas dorsales en forma de H o W in la región
escapular o chevrones; vientre café claro con puntillos
café oscuro *E. exoristus*
- Marcas dorsales compuestas de manchas oscuras;
vientre blanco mate con reticulaciones café o negro *E.*
versicolor
39. Superficies posteriores de los muslos café claro con
reticulaciones café oscuro; quilla vertical en el extremo
del rostro *E. phoxocephalus*
Superficies posteriores de los muslos con otro patrón;
sin quilla vertical en el extremo del rostro 40
40. Flancos uniformemente café claro o café oscuro 41
Flancos con marcas pálidas u oscuras 42
41. Vientre café claro con puntillos negros pequeños;
barras diagonales en los miembros *E. percnopterus*
Vientre crema con puntillos café oscuro; barras
transversales en los miembros *E. seredipitus*
42. Flancos café oscuro con puntillos crema *E. bearsei*
Flancos distinto de café oscuro con puntillos crema ..
..... 43
43. Flancos con manchas oscuras pequeñas; párpados
superiores con tubérculos; rostro acuminado en vista
dorsal *E. rhodostichus*
Flancos sin manchas oscuras; párpados superiores sin
tubérculos; rostro no acuminado en vista dorsal 44
44. Garganta y vientre uniformemente café oscuro
..... *E. incomptus*
Garganta y vientre crema con puntillos café oscuro ..
..... *E. sternothylax*

SPECIES ACCOUNTS

ELEUTHERODACTYLUS CONSPICILLATUS GROUP

The inclusion of several new species necessitates a slight modification of the definition of this group as given by Lynch and Duellman (1997). Most species have smooth skin on the venter, but the skin is areolate in *E. avicuporum*, *caprifer*, and *karcharias*. Finger I is longer than Finger II in most species, but the first two fingers are equal in length in *E. cuneirostris* and *E. karcharias*. The toes are unwebbed in most species, but basal webbing is present in *E. avicuporum*, *malkini*, *metabates*, and *karcharias*. Moreover, two species, *E. citriogaster* and *E. zeuctotylus*, apparently are unique in *Eleutherodactylus* by possessing round, instead of bifid, palmar tubercles.

Lynch and Duellman reported 29 species in the group. This number is increased by five species in Peru—*E. karcharias* and *E. skydmainos* (Flores and Rodríguez, 1997) and three species described herein. Nine members of the group are known from low to moderate elevations in the Andes of northern Peru.

Eleutherodactylus avicuporum new species

Holotype.—LSUMZ 39365, an adult female, from 12 km [by trail] E La Peca (05°36' S, 78°19' W, 1700 m), Provincia

Bagua, Departamento Amazonas, Peru, one of a series collected by L. J. Barkley on 11 June 1978.

Paratypes.—LSUMZ 39361 from 2030 m and KU 288628, LSUMZ 39367–68, 39371–72 from 1700 m, one adult male and five adult females, all from the western slope of the Cordillera Colán east of La Peca.

Referred specimens.—LSUMZ 39359, 39366, 39374–75, 45089, juveniles, and LSUMZ 39370, a partially smashed adult female.

Diagnosis.—A member of the *Eleutherodactylus conspicillatus* Group having (1) skin on dorsum smooth with scattered tubercles; low interocular dermal ridge present in females; skin on venter weakly areolate; discoidal fold prominent; dorsolateral folds present; (2) tympanic membrane smooth, and tympanic annulus prominent, slightly higher than long, its length slightly more than ½ length of eye; (3) snout moderately long, bluntly rounded in dorsal view, rounded in profile; (4) upper eyelid with numerous, small, low tubercles, narrower than IOD; cranial crests absent; (5) vomerine odontophores prominent, triangular; (6) males possessing vocal slits and nonspinous nuptial pads; (7) Finger I slightly longer than II; discs on

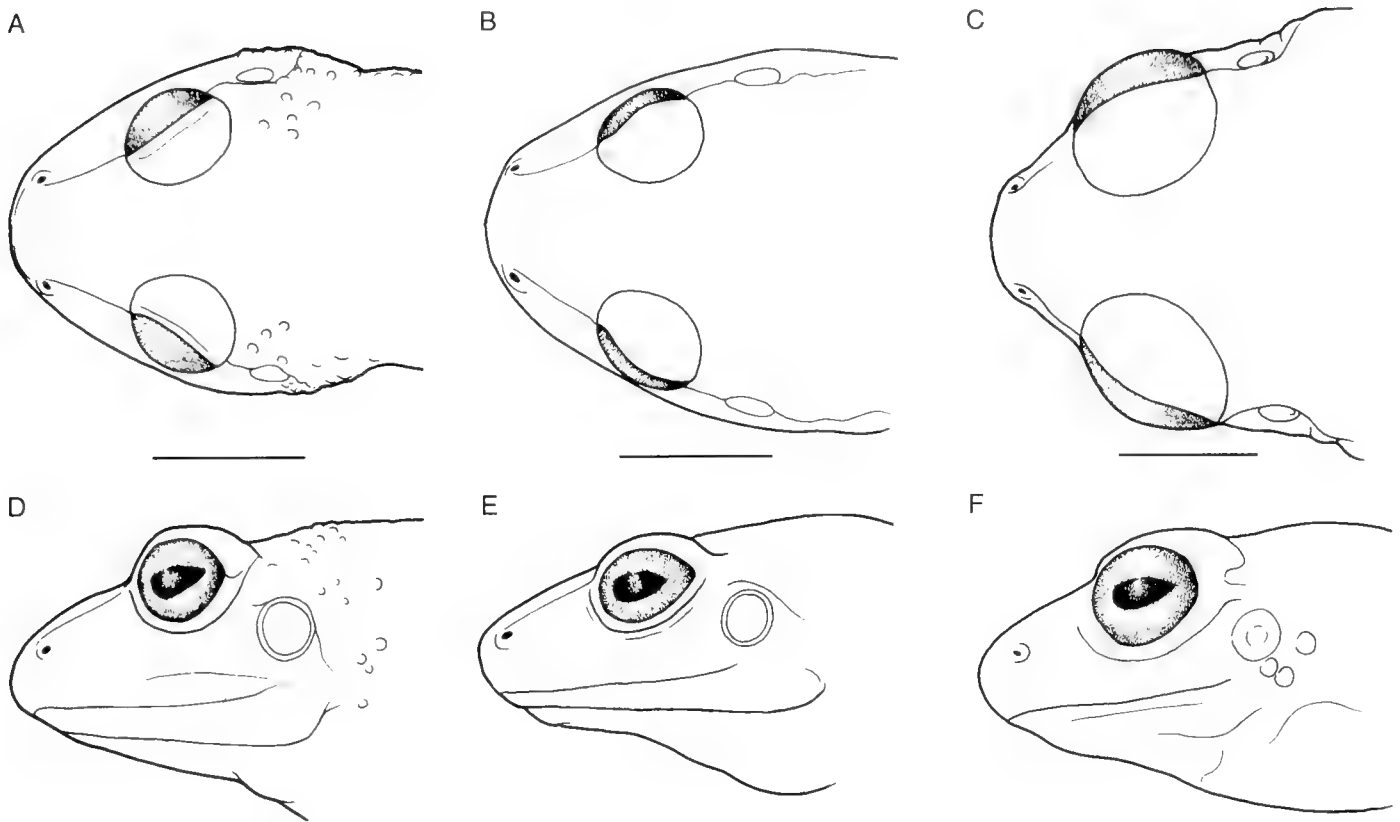

Fig. 5. Dorsal and lateral views of the heads of three species in the *Eleutherodactylus conspicillatus* group. A and D. *E. avicuporum*, LSUMZ 39365. B and E. *E. cuneirostris*, LSUMZ 39369. C and F. *E. metabates*, KU 186504. Scale bars = 5 mm.

outer fingers expanded, truncate, more than twice width of digit proximal to pad; (8) fingers bearing narrow lateral fringes; (9) ulnar tubercles low, round; (10) heel and outer edge of tarsus lacking tubercles; inner edge of tarsus bearing low fold distally; (11) inner metatarsal tubercle elliptical, about 2–3× rounded outer metatarsal tubercle; supernumerary plantar tubercles absent; (12) toes lacking lateral fringes; webbing basal; Toe V slightly longer than III; discs equal in size to those on outer fingers; (13) dorsum brown with single, small, prominent, dark brown middorsal spot; venter tan with diffuse brown reticulations; posterior surfaces of thighs brown with small tan spots; (14) SVL in male 25.2 mm, in 6 females 31.0–34.3 (\bar{x} = 32.4) mm.

By having an interocular dermal fold, *Eleutherodactylus avicuporum* is most similar to *E. skydmainos* of the Amazonian lowlands and lower (<750 m) slopes of the Cordillera Oriental in central and southern Peru; *E. skydmainos* differs by having the venter smooth and immaculate. *Eleutherodactylus cuneirostris* is sympatric with *E. avicuporum*; the former differs by having a long, wedge-shaped snout, many round, dark spots on the dorsum, a broad pale labial stripe, and a smooth venter.

Eleutherodactylus avicuporum is like *E. caprifer* of the Chocóan Region of southern Colombia and Ecuador and *E. karcharias* of the Río Utcubamba Valley on the west slope of the Cordillera Central in northern Peru in having areolate skin on the belly. The latter differs from *E. avicuporum* by having a fin-shaped middorsal tubercle, and the former differs by having a broad brown dorsolateral stripe and many dark chevrons on the dorsum of the body and brown stripes on the throat.

Description.— (n = 1 male, 6 females). Head as wide as body; HW 38.8–42.8 (\bar{x} = 40.3)% SVL; HL 40.1–46.6 (\bar{x} = 42.3)% SVL; snout moderately long, bluntly rounded in dorsal view and rounded in profile (Fig. 5A); E–N 95.1–120.0 (\bar{x} = 106.1)% length of eye; nostrils slightly protuberant, directed laterally; canthus rostralis angular, straight; loreal region noticeably concave; lips rounded; upper eyelid bearing small, rounded tubercles, especially on lateral edge; upper eyelid width 57.1–71.4 (\bar{x} = 61.7)% IOD; supratympanic fold moderately heavy; abruptly curving downward behind tympanum, obscuring dorsal and posterodorsal edge of tympanum; side of head nearly vertical; tympanic membrane prominent; tympanic annulus slightly higher than long; length of tympanic annulus 51.7–

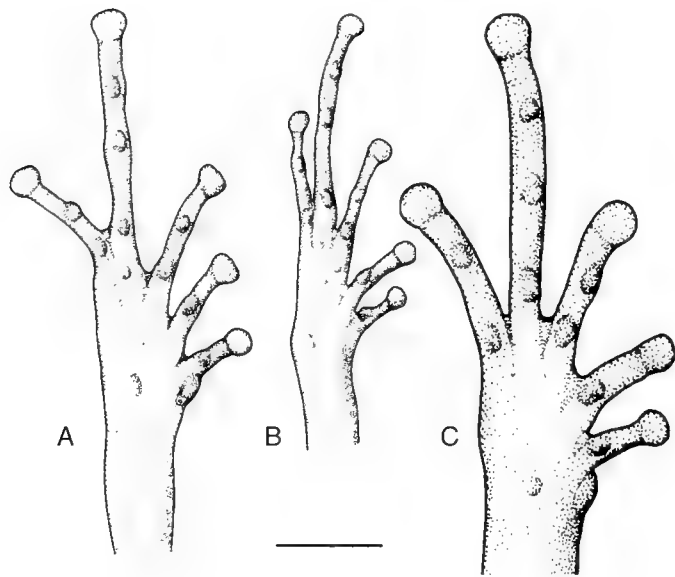

Fig. 6. Feet of three species in the *Eleutherodactylus conspicillatus* group. A. *E. avicuporum*, LSUMZ 39365. B. *E. cuneirostris*, LSUMZ 39369. C. *E. metabates*, KU 186504. Scale = 5 mm.

= 5.3) teeth; tongue about twice as long as wide, barely notched posteriorly; posterior half not adherent to floor of mouth.

Skin on dorsum smooth to very weakly shagreen with scattered small tubercles especially posteriorly and laterally; low interocular dermal ridge (absent in male); dorso-lateral fold weakly tubercular; lateral fold nearly as pronounced as dorso-lateral one; skin on flanks areolate; skin on throat and belly weakly areolate; other ventral surfaces smooth, except coarsely areolate on proximal posteroventral surfaces of thighs; discoidal fold prominent; cloacal sheath short; large tubercles in cloacal region absent. Ulnar tubercles low, round (barely discernible in two specimens; coalesced so as to form low ridge distally on forearm in two specimens); thenar tubercle elevated, elliptical, slightly larger than bifurcate palmar tubercle; palmar supernumerary tubercles absent; subarticular tubercles prominent, subconical; fingers bearing thin lateral fringes; Finger I slightly longer than II; discs on Fingers I and II small, round; discs on outer fingers truncate, more than twice width of digit proximal to pad; all fingers having ventral pads well defined by circumferential grooves. Upper surfaces of hind limbs smooth with scattered minute tubercles; heel and outer edge of tarsus lacking tubercles; inner edge of tarsus bearing low fold distally; inner metatarsal tubercle elevated, elliptical, 2-3 \times rounded outer metatarsal tubercle; plantar supernumerary tubercles absent; subarticular tubercles small, subconical; toes lacking

62.9 (\bar{x} = 57.2)% length of eye; two or three prominent postrictral tubercles below tympanum. Choanae small, ovoid, not concealed by palatal shelf of maxillary arch; vomerine odontophores prominent, triangular in outline, moderately separated medially, located well behind posterior edges of choanae, each odontophore bearing 4-6 (\bar{x}

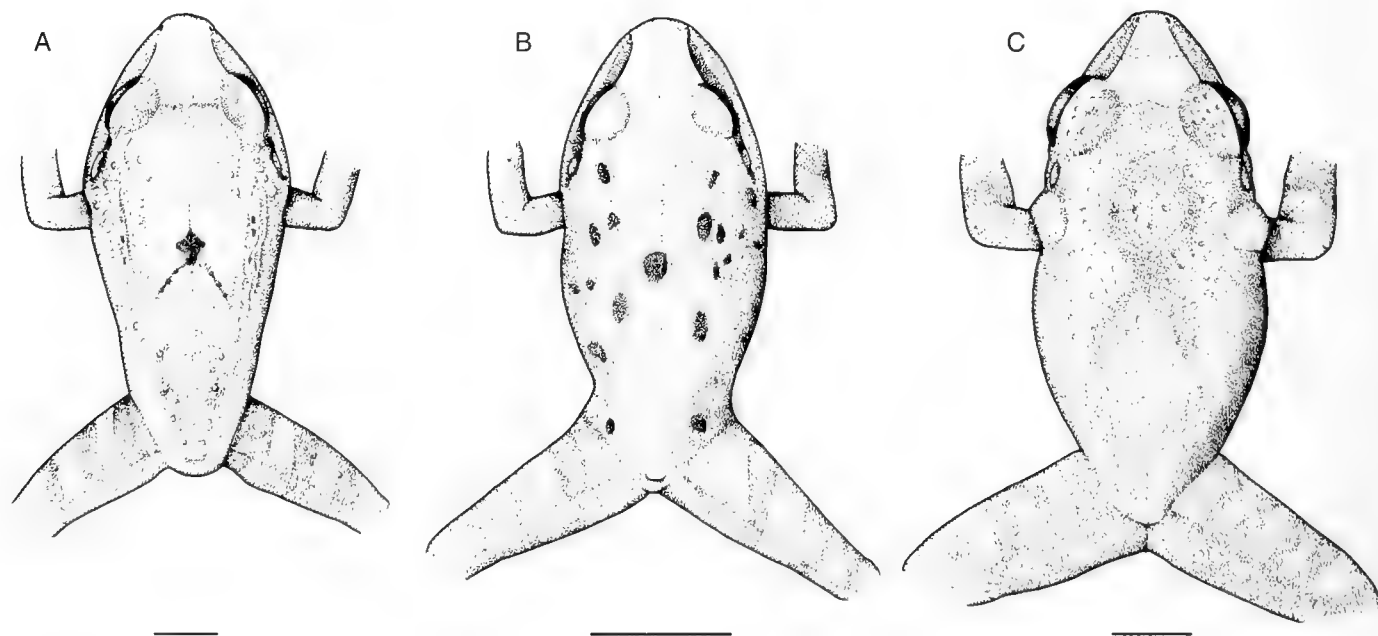

Fig. 7. Dorsal color patterns of three species in the *Eleutherodactylus conspicillatus* group. A. *E. avicuporum*, LSUMZ 39365. B. *E. cuneirostris*, LSUMZ 39369. C. *E. metabates*, KU 186504. Scale bars = 5 mm.

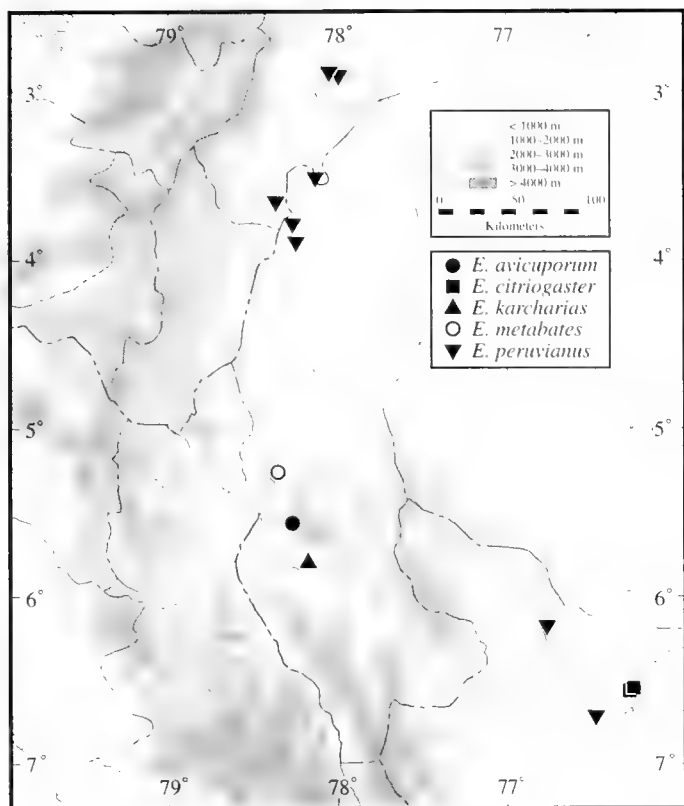

Fig. 8. Localities of known occurrence of five species in the *Eleutherodactylus conspicillatus* group in the Andes of southern Ecuador and northern Peru.

lateral fringes; toes webbed basally; discs on toes about equal in size to those on outer fingers; tip of Toe V extending to distal edge of pentultimate subarticular tubercle on Toe IV; tip of Toe III extending to middle of pentultimate subarticular tubercle on Toe IV (Fig. 6A); when hind limbs flexed perpendicular to axis of body, heels broadly overlapping; shank 58.0–63.9 (\bar{x} = 60.7)% SVL.

Coloration in preservative: Dorsum brown with darker brown markings consisting of small round spot middorsally about midway between scapular region and sacrum, canthal and supratympanic stripes, minute spots posterolaterally from scapular region (2 specimens), row of minute spots just ventral to dorsolateral fold (1 specimen); diffuse brown marking consisting of interorbital bar, labial bars that extend onto margin of lower lip, and narrow transverse bars on forearms, thighs, shanks, and tarsi; one individual with diffuse brown chevron posterior to sacrum, and one with diffuse brown spot posterior to sacrum followed by diffuse transverse mark posteriorly; flanks tan. Posterior surfaces of thighs dark brown with small tan spots, especially distally. Throat and belly tan with diffuse brown reticulation; ventral surfaces of thighs and shanks creamy tan with diffuse brown reticulations

and flecks; ventral surfaces of tarsi black, bordered by narrow creamy tan stripes.

Coloration in life: Unknown.

Measurements of holotype: SVL 33.2, tibia length 20.1, foot length 17.7, head width 13.1, head length 13.9, IOD 4.1, upper eyelid width 2.4, E–N 4.0, eye, 3.5, tympanum 2.0.

Distribution and habitat.—*Eleutherodactylus avicuporum* is known only from elevations of 1700–2030 m on the western slopes of the Cordillera Colán in northern Peru (Fig. 8). All individuals were on the ground in humid montane forest.

Etymology.—The specific name is derived from the Latin *avicupis* meaning bird catcher, and the genitive plural suffix *-orum*. The name is used in recognition of the efforts expended by ornithologists from the Museum of Zoology, Louisiana State University, collecting amphibians in the Cordillera Colán.

Remarks.—The five juveniles have SVLs of 14.0–19.3 (\bar{x} = 17.4) mm. The interocular dermal ridge is weak in three individuals and absent in two, both of which are males. The coloration is like that of the adults, except that in three of the juveniles a diffuse brown chevron is present immediately posterior to the middorsal dark brown spot.

Eleutherodactylus citriogaster Duellman

Eleutherodactylus citriogaster Duellman, 1992b:24. Holotype: KU 212277, adult female, from Cataratas Ahuashiyacu, 730 m, 14 km [by road] NE Tarapoto, Departamento San Martín, Peru.

Diagnosis.—A member of the *Eleutherodactylus* (*Eleutherodactylus*) *conspicillatus* Group having (1) skin on dorsum shagreen, lacking tubercles, that on venter smooth; discoidal fold evident; dorsolateral folds indistinct; (2) tympanic membrane and tympanic annulus prominent, round, its length about 30% length of eye; (3) snout subacuminate in dorsal view, rounded in profile; canthus rostralis angular; (4) upper eyelid lacking tubercles, slightly narrower than or equal to IOD; cranial crests absent; (5) vomerine odontophores triangular, prominent; (6) males having vocal slits and nuptial pads; (7) Finger I longer than II; discs broad, round; (8) fingers lacking lateral fringes; (9) ulnar tubercles present distally; (10) heel and tarsus lacking tubercles; (11) inner metatarsal tubercle oval, 3 \times oval outer metatarsal tubercle; plantar supernumerary tubercles numerous; (12) toes lacking lateral fringes; webbing basal; Toe V longer than III but not extending to distal subarticular tubercle of Toe IV; discs as large as those on fingers; (13) dorsum grayish brown with or without narrow brown chevrons and interorbital bar; venter cream with brown flecks on throat and thighs; (14) SVL in males 31.6–41.3 mm, in females 42.0–51.0 mm.

In general appearance, *Eleutherodactylus citriogaster* (Fig. 9) closely resembles two other species in the *E. conspicillatus*



Eleutherodactylus citriogaster, KU 212277, female, 42.0 mm SVL.



Eleutherodactylus melanogaster, KU 212321, female, 24.7 mm SVL.



Eleutherodactylus patankos, KU 212320, female, 21.6 mm SVL.



Eleutherodactylus pinguis, KU 181284, female, 28.5 mm SVL.



Eleutherodactylus anemerus, KU 219798, male, 20.4 mm SVL (ERW).



Eleutherodactylus ardalonychus, KU 212301, female, 27.4 mm SVL.



Eleutherodactylus ceuthospilus, KU 219776, male, 22.2 mm SVL (ERW).

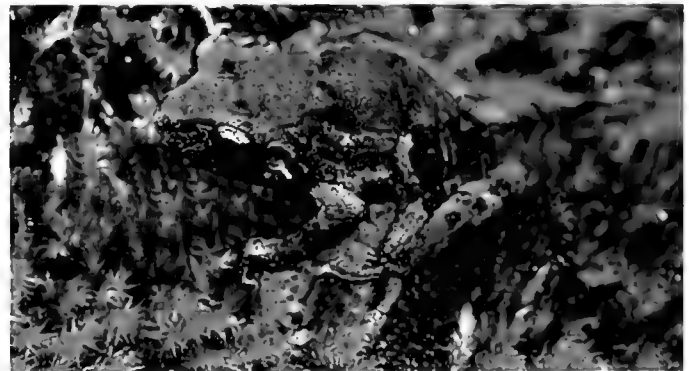

Eleutherodactylus intraquittatus, KU 212297, female, 22.9 mm SVL.

Fig. 9. Eight species of *Eleutherodactylus* from the Andes of northern Peru.



Eleutherodactylus nephophilus, KU 212307, female, 28.3 mm SVL.



Eleutherodactylus petrobardus, KU 212292, male, 28.7 mm SVL.



Eleutherodactylus rhodophilus, KU 219787, male, 25.7 mm SVL (ERW).



Eleutherodactylus rhodostichus, KU 212264, male, 19.3 mm SVL.



Eleutherodactylus rufoculitis, KU 212312, male, 18.1 mm SVL.

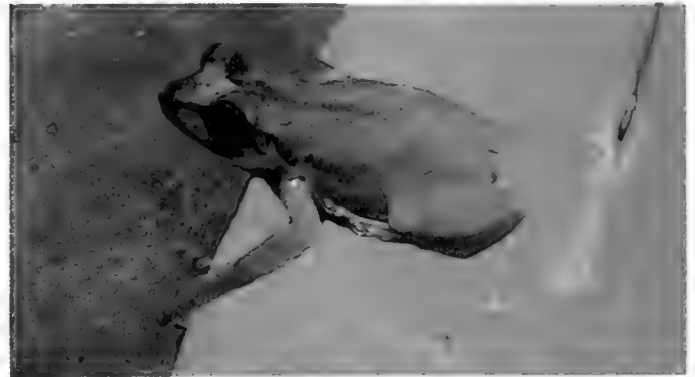

Eleutherodactylus schulleri, KU 212222, male, 26.5 mm SVL.



Eleutherodactylus serendipitus, KU 181279, male, 20.4 mm SVL.



Eleutherodactylus zwiensi, KU 219795, male, 32.1 mm SVL (ERW).

Fig. 10. Eight species of *Eleutherodactylus* from the Andes of northern Peru.

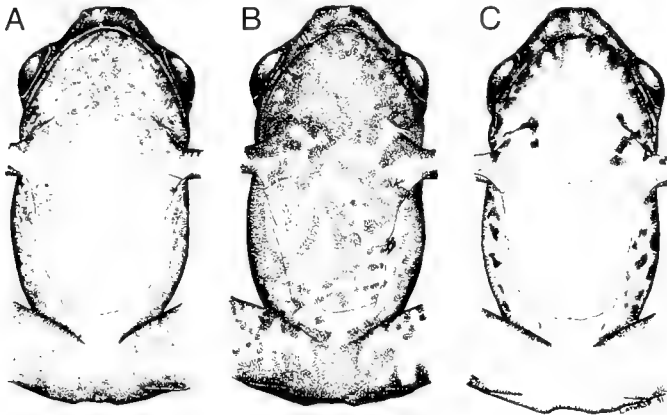

Fig. 11. Ventral color patterns of three large species in the *Eleutherodactylus conspicillatus* group. A. *E. citriogaster*, KU 212287; B. *E. condor*, KU 147020; C. *E. lymani*, KU 181265. From Duellman (1992b).

Group in northern Peru and southern Ecuador—*E. condor* and *E. lymani*. The three species are distinguishable on the basis of color pattern on the posterior surfaces of the thighs—bold black and white spots or reticulations in *E. lymani*, brown with pale flecks in *E. condor*, and dark brown and tan mottling in *E. citriogaster* (Figs. 11A, 12A). Furthermore, *E. citriogaster* has a round, instead of bifid, palmar tubercle. Other members of the *E. conspicillatus* Group are smaller; of those in the upper Amazon Basin and lower slopes of the Andes, *E. conspicillatus*, *malkini*, *metabates*, and *peruvianus* have the posterior surfaces of the thighs dark brown with small cream to red spots, and two of these (*E. malkini* and *E. metabates*) have basal webbing between the toes, whereas *E. fenestratus*, *lanthanites*, and *vilarsi* have uniformly dark brown posterior surfaces of the thighs. Furthermore, *E. lanthanites* has median pale stripe on a dark throat and a prominent tubercle on the heel, and *E. vilarsi* has a bifid palmar tubercle. Other small members of the *E. conspicillatus* Group in the region differ in structure and coloration. *Eleutherodactylus buccinator* has pink spots on the groin on the hidden surfaces of the thigh (Rodríguez, 1994); *E. karcharias* has a prominent fin-shaped middorsal tubercle, and *E. avicuporum* and *E. skydmainos* have an interocular fold. In *E. avicuporum* and *E. karcharias*, the skin on the belly is areolate.

Description.—The description by Duellman (1992b) is adequate and contains all information known about this species.

Distribution and habitat.—This species is known only from elevations of 600–800 m in lower humid montane forest on the slopes of a ridge northeast of Tarapoto, Departamento San Martín, Peru (Fig. 8). All adults were observed at night on rocks in and along cascading streams.

Remarks.—Duellman (1992b) overlooked the fact that the presence of a round, instead of bifid, palmar tubercle

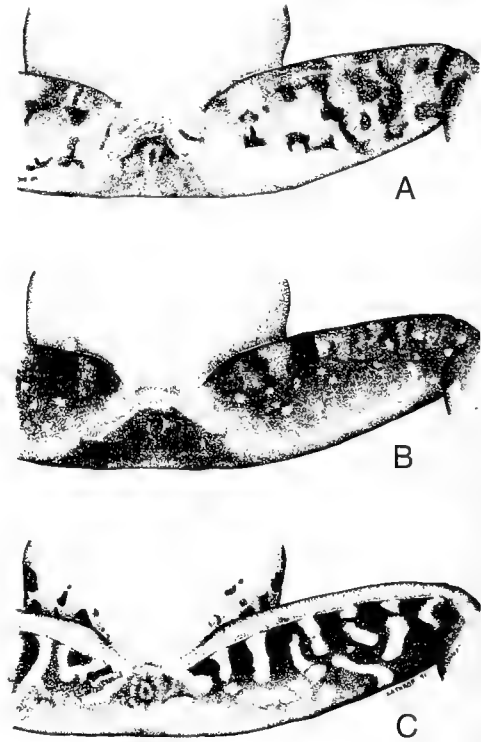

Fig. 12. Color patterns on the posterior surfaces of the thighs in three large species in the *Eleutherodactylus conspicillatus* group. A. *E. citriogaster*, KU 212287. B. *E. condor*, KU 147020. C. *E. lymani*, KU 181265. From Duellman (1992b).

is shared in *Eleutherodactylus* only with *E. zeuctotylus*, a member of the *Eleutherodactylus conspicillatus* Group in northeastern South America (Lynch and Hoogmoed, 1977).

Eleutherodactylus condor Lynch and Duellman

Eleutherodactylus condor Lynch and Duellman, 1980:18. Holotype, KU 146992, a juvenile female, from the Río Piuntza, Cordillera del Cóndor, Provincia Morona-Santiago, Ecuador.

Diagnosis.—A member of the *Eleutherodactylus conspicillatus* Group having (1) skin on dorsum shagreen, that on venter smooth; discoidal fold evident; dorsolateral folds present; (2) tympanic membrane smooth, and tympanic annulus prominent, nearly round, its length about $\frac{1}{2}$ length of eye; (3) snout subacuminate in dorsal view, rounded in profile; (4) upper eyelid lacking tubercles, slightly narrower than or equal to IOD; cranial crests palpable in large females; (5) vomerine odontophores prominent, triangular; (6) males possessing vocal slits and nonspinous nuptial pads; (7) Finger I longer than II; discs expanded, about twice width of digit proximal to pad; (8) fingers lacking lateral fringes; (9) ulnar tubercles absent; (10) heel and tarsus lacking tubercles; (11) inner metatarsal tubercle elongate, 6–8 \times round outer metatarsal tubercle; supernumerary plantar tubercles few or absent; (12) toes bearing narrow lateral fringes; webbing absent; Toe V

slightly longer than III; discs slightly smaller than those on outer fingers; (13) dorsum brown with darker brown markings—labial bars, interorbital bar, chevrons; venter cream with brown blotches; throat heavily pigmented with brown; posterior surfaces of thighs brown with cream or white spots; (14) SVL in males 32.1–39.5 mm, in females 52.6–62.2 mm.

In general appearance, *Eleutherodactylus condor* is most similar to *E. citriogaster* and *E. lymani*. The venter in *E. condor* is creamy white with dense gray pigmentation on the throat, belly, and ventral surfaces of the thighs (Figs. 11B, 12B); the posterior surfaces of the thighs are brown with pale spots. In contrast, in *E. lymani*, the venter is essentially unpigmented, except for dark bars on the margin of the lower lips and posterolaterally on the throat; the posterior surfaces of the thighs are black with bold cream mottling. In *E. citriogaster*, the venter is yellow with brown or gray mottling on the throat, laterally on the belly, and on the ventral surfaces of the thighs; the posterior surfaces of the thighs are mottled dark brown and creamy tan. Furthermore, the palmar tubercle is round, instead of bifid, in *E. citriogaster*. Other members of the *E. conspicillatus* Group are smaller; of those in the upper Amazon Basin and lower slopes of the Andes, *E. conspicillatus*, *malkini*, *metabates* and *peruvianus* have the posterior surfaces of the thighs dark brown with small cream to red spots, and two of these (*E. malkini* and *E. metabates*) have basal webbing between the toes, whereas *E. fenestratus*, *lanthanites*, and *vilarisi* have uniformly dark brown posterior surfaces of the thighs. Furthermore, *E. lanthanites* has median pale stripe on a dark throat and a prominent tubercle on the heel, and *E. vilarisi* has proportionately shorter hind limbs and larger tympana. Other small members of the *E. conspicillatus* Group in the region differ in structure and coloration. *Eleutherodactylus cuneirostris* has a wedge-shaped snout and many small dark spots on the dorsum, and *E. buccinator* has pink spots on the groin on the hidden surfaces of the thigh (Rodríguez, 1994); *E. karcharias* has a prominent fin-shaped middorsal tubercle, and *E. avicuporum* and *E. skydmainos* have an interocular fold. *Eleutherodactylus avicuporum* and *E. karcharias* differ from other members of the group in the region by having areolate skin on the belly.

Distribution and habitat.—The few records for *Eleutherodactylus condor* suggest a rather limited elevational distribution on mountain ranges to the east of the Cordillera Oriental of the Andes (Fig. 13). The species is known from 1975 m in the Cordillera de Cutucú (Duellman and Lynch, 1980), the type locality at 1550 m³ and Coangos at 1500–1600 m (Almendáriz, 1997) on the western slope of the Cordillera del Cóndor, and from 1750 m on the eastern

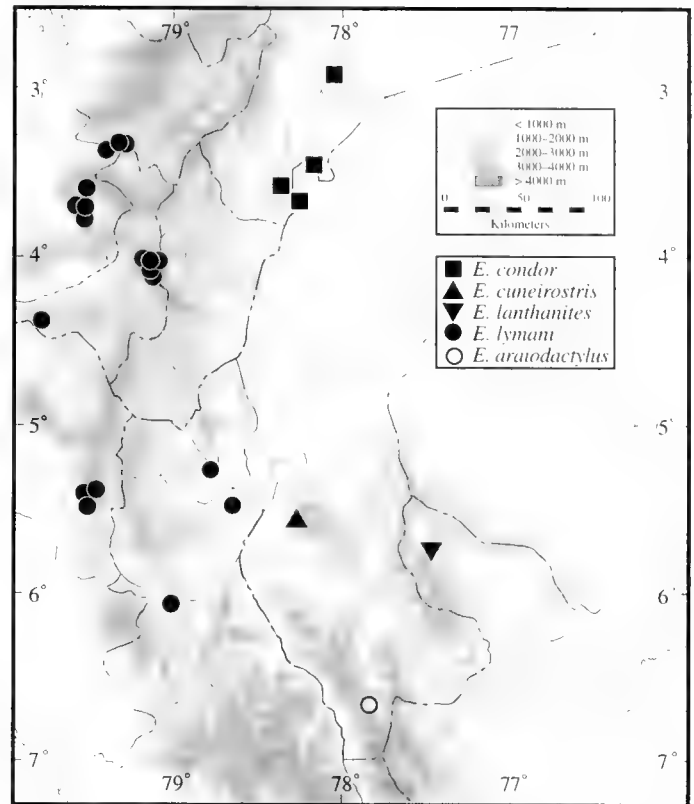

Fig. 13. Localities of known occurrence of four species in the *Eleutherodactylus conspicillatus* group and one species in the *Eleutherodactylus nigrovittatus* group (*E. araiodactylus*) in the Andes of southern Ecuador and northern Peru.

slope of the Cordillera del Cóndor. All individuals have been taken in humid montane forest.

Remarks.—This first Peruvian record is based on USNM 525437, an adult female having a SVL of 60.2 mm. The specimen was obtained at a site on the upper Río Comainas, at the base of Cerro Machinaza in the Cordillera del Cóndor, by Thomas S. Schulenberg on 6 August 1994.

Eleutherodactylus cuneirostris new species

Holotype.—LSUMZ 39369, an adult female, from 12 km [by trail] E La Peca (05°36' S, 78°19' W, 1700 m), Provincia Bagua, Departamento Amazonas, Peru, obtained on 11 June 1978 by L. J. Barkley.

Diagnosis.—A member of the *Eleutherodactylus conspicillatus* Group having (1) skin on dorsum smooth; that on venter smooth; discoidal fold evident; dorsolateral folds absent; (2) tympanic membrane smooth, and tympanic annulus prominent, slightly higher than long, its length slightly more than ½ length of eye; (3) snout long, rounded in dorsal view, protruding well beyond margin of lower lip and acutely rounded in profile; (4) upper eyelid lacking tubercles, narrower than IOD; cranial crests

³Lynch and Duellman (1980) erroneously gave the elevation of the type locality as 1830 m.

absent; (5) vomerine odontophores prominent, oblique; (6) condition of vocal slits and nuptial pads unknown; (7) Finger I equal in length to II; discs on outer fingers expanded, truncate, about twice width of digit proximal to pad; (8) fingers lacking lateral fringes; (9) ulnar tubercles absent; (10) heel and outer edge of tarsus lacking tubercles; inner edge of tarsus bearing low, elliptical tubercle distally; (11) inner metatarsal tubercle elliptical, about 3× subconical outer metatarsal tubercle; supernumerary plantar tubercles absent; (12) toes lacking lateral fringes; webbing absent; Toe V slightly longer than III; discs slightly smaller than those on outer fingers; (13) dorsum tan with small dark brown spots; venter creamy tan with diffuse brown reticulations on belly and ventral surfaces of thighs; posterior surfaces of thighs brown; (14) SVL in one female 29.1 mm.

Eleutherodactylus cuneirostris differs from all other members of the *Eleutherodactylus conspicillatus* Group in the region by having a long, wedge-shaped snout and a conspicuous pale labial stripe. *Eleutherodactylus peruvianus* also has a pale labial stripe, but the dorsum usually has dark chevrons (otherwise uniform tan, red, or green); the throat has dense dark flecks, and there are no reticulations on the belly. Of other small members of the *E. conspicillatus* Group, *E. fenestratus*, *lanthanites*, and *vilarsi* have uniformly dark brown posterior surfaces of the thighs. Furthermore, *E. lanthanites* has median pale stripe on a dark throat and a prominent tubercle on the heel, and *E. vilarsi* has proportionately shorter hind limbs and larger tympana. Other small members of the *E. conspicillatus* Group in the region differ in structure and coloration. *Eleutherodactylus buccinator* has pink spots in the groin and on the hidden surfaces of the thighs (Rodríguez, 1994); *E. karcharias* has a prominent fin-shaped middorsal tubercle and areolate skin on the venter, and *E. avicuporum* and *E. skydmainos* have an interocular fold. *Eleutherodactylus metabates* lacks a pale labial stripe and has X- or chevron-shaped marks on the back. In the larger species in the *E. conspicillatus* group in the region, the venter in *E. condor* is creamy white with dense gray pigmentation on the throat, belly, and ventral surfaces of the thighs; the posterior surfaces of the thighs are brown with pale spots. In *E. lymani*, the venter is essentially unpigmented, except for dark bars on the margin of the lower lips and posterolaterally on the throat; the posterior surfaces of the thighs are black with bold cream mottling. In *E. citriogaster*, the palmar tubercle is round (instead of bifid), and the venter is yellow with brown or gray mottling on the throat, laterally on the belly, and on the ventral surfaces of the thighs; the posterior surfaces of the thighs are mottled dark brown and creamy tan.

Description.— (*n* = 1 female). Head as wide as body. HW 40.5% SVL; HL 44.6% SVL; Snout long, rounded in dorsal view, protruding well beyond margin of lower lip

and acutely rounded in profile, giving wedge-shaped appearance (Fig. 5B); E–N 97.1% length of eye; nostrils notably protuberant, directed laterally; canthus rostralis angular, straight; loreal region noticeably concave; lips rounded; upper eyelid lacking tubercles; upper eyelid width 70.6% IOD; supratympanic fold weak; abruptly curving downward behind tympanum, not obscuring edge of tympanum; side of head inclined ventrolaterally; tympanic membrane prominent; tympanic annulus slightly higher than long; length of tympanic annulus 55.9% length of eye; two low, rounded postictorial tubercles posteroventral to tympanum. Choanae large, round, not concealed by palatal shelf of maxillary arch; vomerine odontophores prominent, oblique, narrowly separated medially, located well behind posterior edges of choanae, each odontophore bearing five teeth. Tongue about twice as long as wide, barely notched posteriorly; posterior half not adherent to floor of mouth.

Skin on dorsum smooth; dorsolateral fold absent; skin on flanks and venter smooth, except coarsely areolate on proximal posteroventral surfaces of thighs; discoidal fold prominent; cloacal sheath short; large tubercles in cloacal region absent. Ulnar tubercles absent. Thenar tubercle elevated, elliptical, slightly smaller than bifurcate palmar tubercle; palmar supernumerary tubercles absent; subarticular tubercles prominent, subconical; fingers lacking lateral fringes; Finger I equal in length to II. Discs on Fingers I and II small, round. Discs on outer fingers truncate, about twice width of digit proximal to pad; all fingers having ventral pads well defined by circumferential grooves. Upper surfaces of hind limbs smooth; heel and outer edge of tarsus lacking tubercles; inner edge of tarsus bearing small, elliptical tubercle distally; inner metatarsal tubercle elevated, elliptical, about 2× subconical outer metatarsal tubercle; plantar supernumerary tubercles absent; subarticular tubercles small, subconical; toes lacking lateral fringes; toes webbed basally; discs on toes about equal in size to those on outer fingers; tip of Toe V extending to distal edge of penultimate subarticular tubercle on Toe IV; tip of Toe III extending to base of penultimate subarticular tubercle on Toe IV (Fig. 6B); when hind limbs flexed perpendicular to axis of body, heels overlap by about one-third length of shank; shank 65.6% SVL.

Coloration in preservative: Dorsum tan with dark brown markings consisting of many small round or ovoid spots on dorsum of body and flanks (Fig. 7B). Canthal and supratympanic stripes; transverse mark above vent and small spots distally on anterior surfaces of thighs; narrow transverse bars on limbs barely evident; broad creamy tan labial stripe. Posterior surfaces of thighs dull brown; throat creamy tan with minute brown flecks; belly and ventral surfaces of thighs creamy tan with diffuse, faint brown reticulations. Ventral surfaces of tarsi black.

Coloration in life: Unknown.

Measurements of holotype: SVL 29.1, tibia length 19.1, foot length 15.6, head width 11.8, head length 13.0, IOD 3.4, upper eyelid width 2.4, E-N 3.3, eye, 3.4, tympanum 1.9.

Distribution and habitat.—*Eleutherodactylus cuneirostris* is known only from 1700 m in humid montane forest on the western slopes of the Cordillera Colán in northern Peru (Fig. 13).

Etymology.—The specific name is an adjective from the Latin *cuneus* meaning wedge and the Latin *rostrum* meaning snout. The name refers to the wedge-shaped snout.

Remarks.—Among species of *Eleutherodactylus* in Ecuador and Peru, the long, wedge-shaped snout of this species is approached only by the long, subacuminate snout in *E. longirostris*, a member of the *Eleutherodactylus* (*Craugastor*) *fitzingeri* group in the Chocóan region.

Eleutherodactylus karcharias Flores and Rodríguez

Eleutherodactylus karcharias Flores and Rodríguez, 1997:392. Holotype, MCZ 89075, immature female, from Alva, 1000m, between Chachapoyas and Bagua Grande, Departamento Amazonas, Peru.

Diagnosis.—A member of the *Eleutherodactylus conspicillatus* Group having (1) skin on dorsum shagreen with scattered tubercles, especially on flanks, prominent fin-shaped middorsal tubercle; skin on venter areolate; discoidal fold prominent; dorsolateral and flank folds present; (2) tympanic membrane smooth, and tympanic annulus prominent, slightly higher than long, its length about $\frac{1}{4}$ to $\frac{1}{2}$ length of eye; (3) snout rounded in dorsal view and in profile; (4) upper eyelid lacking tubercles, broader than IOD; cranial crests present; (5) vomerine odontophores prominent, triangular; (6) condition of vocal slits and nuptial pads unknown; (7) Finger I equal in length to II; discs expanded, about twice width of digit proximal to pad; (8) fingers bearing broad lateral fringes; (9) ulnar tubercles absent; (10) heel and tarsus lacking tubercles; (11) inner metatarsal tubercle oval to elongate, 2–6× round outer metatarsal tubercle; (12) toes bearing broad lateral fringes; webbing basal; Toe V slightly longer than III; discs nearly equal in size to those on outer fingers; (13) dorsum pale grayish tan to brown with darker brown markings—interorbital and labial bars, canthal and supratympanic stripes, W-shaped mark in scapular region, two dorsal chevrons (anterior one enclosing black spot with middorsal tubercle), triangular mark enclosing vent, and diagonal bars on limbs; venter cream with brown flecks, most dense on chest and throat; posterior surfaces of thighs brown with cream flecks or spots; (14) SVL in subadult female 30.4.

Except for three species, all members of the *Eleutherodactylus conspicillatus* Group have smooth venters. By having an areolate venter, *Eleutherodactylus karcharias* resembles *E. caprifer* of the Chocóan Region of southern

Colombia and Ecuador and *E. avicuporum* of the Cordillera Colán. The latter differs from *E. karcharias* by lacking a fin-shaped middorsal tubercle and distinct dorsal markings, and the former differs by having a broad brown dorsolateral stripe and many dark chevrons on the dorsum of the body and brown stripes on the throat.

Description.—Nothing can be added to the description by Flores and Rodríguez (1997).

Distribution and habitat.—*Eleutherodactylus karcharias* is known from a single locality at an elevation of 1000 m in the valley of the Río Utcubamba (tributary of the Río Marañón) in the northern part of the Cordillera Central in northern Peru (Fig. 8). The specimens were “taken from moist leaf litter in cloud forest” (Flores and Rodríguez, 1997).

Remarks.—This species is known from only seven immature females.

Eleutherodactylus lanthanites Lynch

Eleutherodactylus lanthanites Lynch, 1975b:10. Holotype, KU 146144, an adult female, from Santa Cecilia, 340 m, Provincia Napo, Ecuador.

Diagnosis.—A member of the *Eleutherodactylus conspicillatus* Group having (1) skin on dorsum finely tuberculate with scattered larger tubercles, that on venter smooth; discoidal fold prominent; dorsolateral folds absent; (2) tympanic membrane smooth, and tympanic annulus prominent, nearly round, its length about $\frac{1}{2}$ length of eye; (3) snout long, subacuminate in dorsal view, rounded in profile; (4) upper eyelid lacking tubercles, narrower than IOD; cranial crests absent; (5) vomerine odontophores prominent, oblique; (6) males possessing vocal slits and nonspinous nuptial pads; (7) Finger I longer than II; discs expanded, about twice width of digit proximal to pad; (8) fingers lacking lateral fringes; (9) ulnar tubercles absent; (10) heel bearing conical tubercle; outer edge of tarsus bearing row of indistinct tubercles; inner tarsal tubercles and fold absent; (11) inner metatarsal tubercle elongate, about 5× conical outer metatarsal tubercle; supernumerary plantar tubercles few in number; (12) toes lacking lateral fringes; webbing absent; Toe V slightly longer than III; discs equal in size to those on outer fingers; (13) dorsum brown with darker brown markings (usually chevrons); venter cream with dark flecks; throat heavily pigmented with brown or black, defining median white stripe; posterior surfaces of thighs brown with cream flecks; (14) SVL in males 21.7–27.9 mm, in females 27.5–45.4 mm (Lynch and Duellman, 1980).

Eleutherodactylus lanthanites differs from all other members of the *Eleutherodactylus conspicillatus* Group, except *E. gutturalis*, by having a dark throat with a median white stripe. The latter species, which inhabits the Guianan Region, differs from *E. lanthanites* by lacking a tubercle on the heel and by having proportionately longer hind limbs (Hoogmoed et al., 1977).

Distribution and habitat.—*Eleutherodactylus lanthanites* is widespread in the upper Amazon Basin in southern Colombia, Ecuador, extreme western Brazil, and northern Peru (Lynch, 1980; Duellman and Mendelson, 1995). The species ascends the eastern slopes of the Andes to elevations of 1440 m in southern Colombia and 1490 m in Ecuador (Lynch and Duellman, 1980). In northern Peru, the species has been taken only at Venceremos at an elevation of 1630 m, Departamento San Martín (Fig. 13). The single individual was on the ground by day in humid montane forest.

Remarks.—A juvenile male has a SVL of 19.0 mm. In life, the dorsum was tan with dull red markings. The anterior, ventral, and posterior surfaces of the thighs were orange, and the face mask was dark brown. The belly was yellow with black flecks, and the throat was black with cream spots and a median white stripe. The iris was bronze with a median, horizontal, red streak. This juvenile is assigned to *Eleutherodactylus lanthanites* on the basis of the throat pattern, which is unique to this species in the *Eleutherodactylus conspicillatus* Group.

Eleutherodactylus lymani Barbour and Noble

Eleutherodactylus lymani Barbour and Noble, 1920:403. Holotype: MCZ 5422, young female, from Perico, Departamento Cajamarca, Peru.

Eleutherodactylus carrioni Parker, 1932:23. Holotype: BM 1947.2.15.99, adult female, from Loja, Provincia Loja, Ecuador. Synonymy fide Lynch, 1969:263.

Eleutherodactylus lymani—Lynch, 1969:263.

Diagnosis.—A member of the *Eleutherodactylus* (*Eleutherodactylus*) *conspicillatus* Group having (1) skin on dorsum shagreen with scattered tubercles, that on venter smooth; discoidal fold prominent; dorsolateral folds present; (2) tympanic membrane and tympanic annulus prominent, round, its length about $\frac{1}{2}$ length of eye; (3) snout subacuminate in dorsal view, rounded in profile; canthus rostralis angular; (4) upper eyelid lacking tubercles, usually narrower than IOD; cranial crests absent; (5) vomerine odontophores subtriangular in outline, prominent; (6) males lacking vocal slits; nuptial pads present; (7) Finger I longer than II; discs small; (8) fingers bearing lateral keels; (9) ulnar tubercles absent; (10) heel and outer edge of tarsus lacking tubercles; inner surface of tarsus bearing fold; (11) inner metatarsal tubercle elongate, 4 \times round outer metatarsal tubercle; plantar supernumerary tubercles absent; (12) toes bearing lateral fringes; webbing absent; Toe V slightly longer than III; discs as large as those on fingers; (13) dorsum brown with dark brown to black markings; venter cream to white; groin and posterior surfaces of thighs black with white spots or reticulations; (14) SVL in males 25.7–45.3 mm, in females 48.4–69.3 mm.

In size and general appearance, *Eleutherodactylus lymani* closely resembles two other species in the *E. conspicillatus*

Group in northern Peru and southern Ecuador—*E. condor* and *E. citriogaster*. The three species are distinguishable on the basis of color pattern on the posterior surfaces of the thighs—bold black and white spots or reticulations in *E. lymani*, brown with pale flecks in *E. condor*, and dark brown and tan mottling in *E. citriogaster* (Figs. 11C, 12C); furthermore, *E. citriogaster* has a round, instead of bifid, palmar tubercle. Other members of the *E. conspicillatus* Group are smaller; of those in the upper Amazon Basin and lower slopes of the Andes, *E. conspicillatus*, *malkini*, *metabates*, and *peruvianus* have the posterior surfaces of the thighs dark brown with small cream to red spots, and two of these (*E. malkini* and *E. metabates*) have basal webbing between the toes, whereas *E. fenestratus*, *lanthanites*, and *vilarisi* have uniformly dark brown posterior surfaces of the thighs. Furthermore, *E. lanthanites* has median pale stripe on a dark throat and a prominent tubercle on the heel, and *E. vilarisi* has proportionately shorter hind limbs and larger tympana. Other small members of the *E. conspicillatus* Group in the region differ in structure and coloration. *Eleutherodactylus cuneirostris* has a wedge-shaped snout and many small dark spots on the dorsum, and *E. buccinator* has pink spots in the groin and on the hidden surfaces of the thighs (Rodríguez, 1994); *E. karcharias* has a prominent fin-shaped, middorsal tubercle, and *E. avicuporum* and *E. skydmainos* have an interocular fold. Two members of the *E. conspicillatus* Group in the region (*E. avicuporum* and *E. karcharias*) have areolate skin on the belly.

Description.—Lynch (1969) provided a thorough redescription of the species, which was augmented by Lynch and Duellman (1997).

Distribution and habitat.—*Eleutherodactylus lymani* has a reasonably broad distribution on the drier Pacific slopes and lowlands of southern Ecuador and northwestern Peru (Fig. 13). Most records are at elevations of less than 1600 m, but it has been found as high as 3000 m in subparamo in Provincia Loja, Ecuador. Three specimens (KU 196464, 196509; LSUMZ 19553) are from 28 km N of Santa Cruz, 725 m, Provincia Jaén, Departamento Cajamarca, Peru; this village is on the road between Jaén and Bellavista in the valley of the Río Marañón. The frogs were collected by Richard Thomas on 8 July 1968; they were under rocks at the edge of a stream in thorn forest with trees 12–18 m high. LSUMZ 32460 is from 20 km SW of Chiriaco, Provincia Bagua, Departamento Amazonas, Peru; this locality also is in the valley of the Río Marañón.

Lynch (1969:266) listed MCZ 5436 as being from Palambra in Departamento Cajamarca. We have been unable to find a Palambra in Departamento Cajamarca, but a village by that name exists at 5°23' S, 79°37' W in Departamento Piura. Although no place by that name was cited in Noble's (1921) account of his travels in northern

Peru, the village is in the immediate vicinity of the route described by Noble; furthermore, Barbour and Noble (1920:395) stated: "The towns of Huancabamba and Palambra are on the western range of the Andes, on the border of Piura." Duellman and Wild (1993) recorded *Eleutherodactylus lymani* from Canchaque, 1120 m; Palambra is about 2 km south of Canchaque and at the same elevation.

Remarks.—Of the specimens reported herein, one (KU 196464) is a subadult male having a SVL of 34.6 mm and the other (LSU 19553) is a female having a SVL of 47.0 mm.

Eleutherodactylus metabates new species

Holotype.—KU 186504, an adult male, from 20 km [by road] SW of Chiriaco (05°13' S, 78°17' W, 525 m), Provincia Bagua, Departamento Amazonas, obtained by Richard Thomas on 16 December 1974.

Paratypes.—LSUMZ 32460, an adult male from the type locality.

Diagnosis.—A member of the *Eleutherodactylus conspicillatus* Group having (1) skin on dorsum smooth weakly tuberculate, that on venter smooth; discoidal fold prominent; dorsolateral folds absent; (2) tympanic membrane smooth, and tympanic annulus prominent, slightly higher than long, its length slightly less than ½ length of eye; (3) snout moderately long, rounded in dorsal view and in profile; (4) upper eyelid with numerous, small, low tubercles, as wide as IOD; cranial crests absent; (5) vomerine odontophores prominent, oval; (6) males possessing vocal slits, lacking nuptial pads; (7) Finger I slightly longer than II; discs on outer fingers expanded, nearly truncate, more than twice width of digit proximal to pad; (8) fingers bearing narrow lateral fringes; (9) ulnar tubercles absent; (10) heel and outer edge of tarsus lacking tubercles; inner edge of tarsus bearing distinct fold distally; (11) inner metatarsal tubercle elevated, elliptical, about 10× subconical outer metatarsal tubercle; supernumerary plantar tubercles absent; (12) toes bearing broad lateral fringes; webbing basal; Toe V slightly longer than III; discs slightly smaller than those on outer fingers; (13) dorsum brown with faintly darker X- or chevron-shaped marks; venter cream with diffuse brown flecks on throat; posterior surfaces of thighs brown with small cream flecks; (14) SVL in two males 29.9–32.2 (\bar{x} = 31.1) mm; females unknown.

Eleutherodactylus metabates is most similar to *E. conspicillatus* and *E. peruvianus*, both of which have small, pale flecks on the posterior surfaces of the thighs, but both species lack webbing and usually have dark face masks; moreover, *E. peruvianus* has dark mottling on the throat and chest. The structurally similar *E. malkini* has more webbing between the toes and black and cream mottling on the posterior surfaces of the thighs. Of other small mem-

bers of the *E. conspicillatus* Group, *E. fenestratus*, *lanthanites*, and *vilarsi* have uniformly dark brown posterior surfaces of the thighs. Furthermore, *E. lanthanites* has median pale stripe on a dark throat and a prominent tubercle on the heel, and *E. vilarsi* has proportionately shorter hind limbs and larger tympana. Other small members of the *E. conspicillatus* Group in the region differ in structure and coloration. *Eleutherodactylus buccinator* has pink spots in the groin and on the hidden surfaces of the thighs (Rodríguez, 1994); *E. karcharias* has a prominent middorsal tubercle, and *E. avicuporum* and *E. skydmainos* have an interocular fold. *Eleutherodactylus avicuporum* and *E. karcharias* have areolate skin on the belly, and *E. cuneirostris* has a wedge-shaped snout and many round, dark brown spots on the dorsum. In the larger species in the *E. conspicillatus* group in the region, the venter in *E. condor* is creamy white with dense gray pigmentation on the throat, belly, and ventral surfaces of the thighs; the posterior surfaces of the thighs are brown with pale spots. In *E. lymani*, the venter is essentially unpigmented, except for dark bars on the margin of the lower lips and posterolaterally on the throat; the posterior surfaces of the thighs are black with bold cream mottling. In *E. citriogaster*, the palmar tubercle is round (instead of bifid), and the venter is yellow with brown or gray mottling on the throat, laterally on the belly, and on the ventral surfaces of the thighs; the posterior surfaces of the thighs are mottled dark brown and creamy tan.

Description.—(n = 2 males). Head wider than body; HW 37.1–37.3 (\bar{x} = 37.1)% SVL; HL 41.8–42.2 (\bar{x} = 42.0)% SVL; snout moderately long, rounded in dorsal view and in profile (Fig. 5C); E–N 86.0–92.7 (\bar{x} = 89.4)% length of eye; nostrils barely protuberant, directed dorsolaterally; canthus rostralis angular, straight; loreal region nearly flat; lips rounded; upper eyelid bearing small, rounded tubercles; upper eyelid width 100.0–103.4 (\bar{x} = 101.7)% IOD; supratympanic fold moderately heavy; abruptly curving downward behind tympanum, obscuring dorsal and posterodorsal edge of tympanum; side of head nearly vertical; tympanic membrane prominent; tympanic annulus slightly higher than long; length of tympanic annulus 41.3–41.5 (\bar{x} = 41.4)% length of eye; two prominent postictal tubercles posteroventral to tympanum. Choanae small, round, partly concealed by palatal shelf of maxillary arch; vomerine odontophores prominent, oval, moderately separated medially, located well behind posterior edges of choanae, each odontophore bearing 5–6 (\bar{x} = 5.5) teeth; tongue nearly twice as long as wide, barely notched posteriorly; posterior one third not adherent to floor of mouth.

Skin on dorsum weakly tuberculate; dorsolateral fold absent; skin on flanks tuberculate; skin on venter smooth; discoidal fold prominent; cloacal sheath short; large tubercles in cloacal region absent. Ulnar tubercles absent;

thenar tubercle elevated, elliptical, slightly smaller than bifid palmar tubercle; palmar supernumerary tubercles absent; subarticular tubercles prominent, subconical; fingers bearing lateral fringes; first finger slightly longer than second; discs on Fingers I and II small, round; discs on outer fingers nearly truncate, more than twice width of digit proximal to pad; all fingers having ventral pads well defined by circumferential grooves. Upper surfaces of hind limbs smooth; heel and outer edge of tarsus lacking tubercles; inner edge of tarsus bearing distinct fold distally; inner metatarsal tubercle elevated, elliptical, about 10× subconical outer metatarsal tubercle; plantar supernumerary tubercles absent; subarticular tubercles small, rounded; toes bearing broad lateral fringes; toes webbed to basal subarticular tubercles; discs on toes slightly smaller than those on outer fingers; tip of Toe V extending to middle of penultimate subarticular tubercle on Toe IV; tip of Toe III extending to base of penultimate subarticular tubercle on Toe IV (Fig. 6C); when hind limbs flexed perpendicular to axis of body, heels overlapping by about ½ length of shank; shank 62.2–62.4 (\bar{x} = 62.3)% SVL.

Coloration in preservative: Dorsum brown with faint darker brown markings consisting of interorbital bar, labial bars, supratympanic stripe (but no canthal stripe), X- or chevron-shaped marks on the back, and barely discernible transverse bars on limbs (Fig. 7C); flanks tan with diffuse brown diagonal bars; axilla cream with small brown spots; posterior surfaces of thighs brown with cream flecks; venter cream with diffuse brown flecks on throat.

Coloration in life: Unknown.

Measurements of holotype: SVL 32.2, tibia length 20.1, foot length 17.0, head width 12.0, head length 13.6, IOD 3.2, upper eyelid width 3.2, E–N 3.5, eye, 4.6, tympanum 1.9.

Distribution and habitat.—*Eleutherodactylus metabates* is known only from the type locality at an elevation of 525 m in the Río Marañón Valley in Departamento Amazonas, Peru (Fig. 8). This region supports thorn forest.

Etymology.—The specific name is a Greek noun meaning leaper. The name is applied to this long-legged species that presumably is capable of lengthy jumps.

Remarks.—The paratype (adult male having a SVL of 29.9 mm) differs from the holotype only by having a more pallid coloration.

Eleutherodactylus peruvianus (Melin)

Hylodes peruvianus Melin, 1941:43. Holotype, NHMG 490, an adult female, from Roque, Departamento San Martín, Peru

Eleutherodactylus peruvianus—Gorham, 1966:91.

Diagnosis.—A member of the *Eleutherodactylus conspicillatus* Group having (1) skin on dorsum shagreen with scattered tubercles, that on venter smooth; discoidal fold prominent; dorsolateral folds present; (2) tympanic

membrane smooth, and tympanic annulus prominent, nearly round, its length about ½ length of eye; (3) snout rounded to subacuminate in dorsal view, rounded in profile; (4) upper eyelid lacking tubercles, broader than IOD; cranial crests absent; (5) vomerine odontophores prominent, triangular; (6) males possessing vocal slits and white, nonspinous nuptial pads; (7) Finger I longer than II; discs expanded, about twice width of digit proximal to pad; (8) fingers bearing lateral fringes; (9) ulnar tubercles absent; (10) heel and tarsus lacking tubercles, except for small tubercle on inner edge of tarsus; (11) inner metatarsal tubercle oval, about 6× subconical outer metatarsal tubercle; supernumerary plantar tubercles few in number; (12) toes bearing lateral fringes; webbing absent; Toe V slightly longer than III; discs equal in size to those on outer fingers; (13) dorsum usually brown with darker brown chevrons; venter cream with brown flecks, most dense on throat; posterior surfaces of thighs brown with cream spots; (14) SVL in males 29.2–35.8 mm, in females 38.6–46.4 mm (Lynch and Duellman, 1980).

Eleutherodactylus peruvianus is most similar to *E. conspicillatus*, *malkini*, and *metabates*, all of which have pale spots on the posterior surfaces of the thighs. The structurally similar *E. conspicillatus* lacks dark pigmentation on the throat and chest and lacks labial bars, whereas *E. malkini* and *E. metabates* have distinct webbing between the toes (absent in *E. peruvianus*), and *E. malkini* has black and cream mottling on the posterior surfaces of the thighs. Of other small members of the *E. conspicillatus* Group, *E. fenestratus*, *lanthanites*, and *vilarsi* have uniformly dark brown posterior surfaces of the thighs. Furthermore, *E. lanthanites* has median pale stripe on a dark throat and a prominent tubercle on the heel, and *E. vilarsi* has proportionately shorter hind limbs and larger tympana. Other small members of the *E. conspicillatus* Group in the region differ in structure and coloration. *Eleutherodactylus buccinator* has pink spots in the groin and on the hidden surfaces of the thighs (Rodríguez, 1994), and *E. cuneirostris* has many small, dark spots on the dorsum; *E. karcharias* has a prominent mid-dorsal tubercle, and *E. avicuporum* and *E. skydmainos* have an interocular fold (Flores and Rodríguez, 1997). In the larger species in the *E. conspicillatus* Group in the region, the venter in *E. condor* is creamy white with dense gray pigmentation on the throat, belly, and ventral surfaces of the thighs; the posterior surfaces of the thighs are brown with pale spots. In *E. lymani*, the venter is unpigmented, except for dark bars on the margin of the lower lips and posterolaterally on the throat; the posterior surfaces of the thighs are black with bold cream mottling. In *E. citriogaster*, the palmar tubercle is round (instead of bifid), and the venter is yellow with brown or gray mottling on the throat, laterally on the belly, and on the ventral surfaces of the thighs; the posterior surfaces of the thighs are mottled dark brown and creamy tan.

Distribution and habitat.—*Eleutherodactylus peruvianus* is widespread in the upper Amazon Basin in western Brazil, Ecuador, and Peru (Lynch, 1980; Lynch and Duellman, 1980). Herein, we record it at elevations of 950 and 1080 m on the eastern slopes of the Cordillera Central in northern Peru—respectively, KU 217313 from 15.4 km SW of Zapatero and KU 212291 from Abra Tangarana, 7 km [by road] NE San Juan de Pacaysapa, both in Provincia Lamas, Departamento San Martín (Fig. 8). The latter was on the ground by a stream during the day. The species ascends the eastern slopes of the Andes to elevations of nearly 2000 m in Ecuador and Peru (Lynch and Duellman, 1980). It has been reported from elevations of 1700–1975 m in the Cordillera de Cutucú (Duellman and Lynch, 1988), from 1500–1830 m on the western slopes of the Cordillera del Cóndor (Almendáriz, 1997; Lynch and Duellman, 1980), and from 665–1750 m on the eastern slopes of the Cordillera del Cóndor in Peru (Reynolds and Icochea, 1997). Two of the latter were on vegetation at night, and one was in a bromeliad; all were in humid montane forest.

Remarks.—Two specimens (USNM 525438–39) from the upper Río Comainas, 1750 m, base of Cerro Machinaza, Departamento Amazonas, are adult females having SVLs of 37.8 and 37.2 mm, respectively. A third individual (USNM 525440) from the Puesto Vigilancia, Río Comainas, 665 m, Departamento Amazonas, is a male having a SVL of 28.7 mm. In USNM 525438, the dorsum is uniform olive tan, and the flanks are brown, whereas in the other specimens, the dorsum is tan with brown chevrons. In the females, the throat and chest have dark gray mottling, whereas only small gray flecks are present on the throat and chest of the male. The coloration of living individuals was: USNM 525438—Dorsum reddish brown; flanks and legs brown; dark canthal mask; chin mottled brown-yellow; chest and belly yellow with brown spotting; underside of legs yellow with brown spotting; iris bronze (R. P. Reynolds field notes, 17 July 1994). USNM 525440—Dorsum tan with light brown chevrons; dark canthal stripe; legs barred; rear of thighs brown with yellow spots; chin green; belly cream (Robert P. Reynolds field notes, 31 July 1994). The specimen from Abra Tangarana is a juvenile with a SVL of 23.5 mm. In life, the dorsum was dull olive-tan with brown chevrons, and the posterior surfaces of the thighs were brown with pale red flecks; the ventral surfaces of the limbs were pale yellow (WED field notes, 5 February 1989).

ELEUTHERODACTYLUS NIGROVITTATUS GROUP

This group was defined by Lynch (1989) as having the skin on the venter smooth, dorsolateral folds present or absent, Finger I longer than Finger II, discs on digits not expanded, and vomerine odontophores present. Lynch and Duellman (1997) added relative length of the toes—Toe III

longer than Toe IV. The inclusion of the new species described below necessitates a slight modification of the definition—Finger I longer than, or equal in length to, Finger II, and Toe IV shorter than, or equal in length to Toe III.

In addition to the species described herein, the group includes four species—*E. latens* and *E. manipus* in the Andes of Colombia, *E. classodiscus* in the Cordillera Oriental in Ecuador, and *E. nigrovittatus* in the upper Amazon Basin and lower slopes of the Andes in Colombia, Ecuador, and Peru. (See map in Lynch et al., 1997.)

Eleutherodactylus araiodactylus new species

Holotype.—UF 40764, subadult female, from 24 km [by road] SW Leimebamba (06°40' S, 77°50' W, 3370 m), Provincia Chachapoyas, Departamento Amazonas, Peru, obtained on 25 April 1972 by Fred G. Thompson.

Diagnosis.—A member of the *Eleutherodactylus (Eleutherodactylus) nigrovittatus* Group having (1) skin on dorsum smooth; that on venter smooth; discoidal fold evident; dorsolateral folds present; (2) tympanic membrane smooth, and tympanic annulus prominent, nearly round, its length about ½ length of eye; (3) snout moderately long, rounded in dorsal view and in profile; (4) upper eyelid lacking tubercles, narrower than IOD; cranial crests absent; (5) vomerine odontophores prominent, elongately oval; (6) condition of vocal slits and nuptial pads unknown; (7) Finger I equal in length to II; discs on outer fingers narrow, acutely rounded; (8) fingers bearing lateral fringes; (9) ulnar tubercles absent; (10) heel and tarsus lacking tubercles; (11) inner metatarsal tubercle elliptical, about 2× subconical outer metatarsal tubercle; supernumerary plantar tubercles few; (12) toes bearing lateral fringes; webbing absent; Toes V and III equal in length; discs equal to those on outer fingers; (13) dorsum tan with middorsal brown marking; venter and posterior surfaces of thighs tan; (14) SVL in one female 24.5 mm.

Eleutherodactylus araiodactylus is readily distinguished from all other members of the genus in the Andes of northern Peru by having a combination of smooth skin on the venter and undilated discs on the digits. The only other species in the region having smooth skin on the venter are members of the *Eleutherodactylus conspicillatus* Group, all of which have greatly expanded digital discs. From other members of the *Eleutherodactylus nigrovittatus* Group, *E. araiodactylus* differs by having Fingers I and II of equal length (instead of Finger I > II), Toes III and IV of equal length (instead of Toe III > V), digits acutely rounded instead of nearly pointed, and a diagonal dermal ridge posteroventral to the tympanum. Moreover, *E. araiodactylus* differs from *E. classodiscus* by having dorsolateral folds and lateral fringes on the digits; the latter character also differentiates *E. araiodactylus* from *E. nigrovittatus*, a species with proportionately shorter fingers and more robust body. The

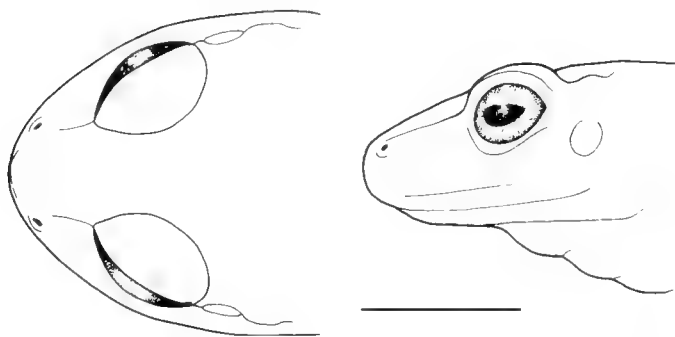

Fig. 14. Dorsal and lateral views of the head of *Eleutherodactylus araiodactylus*, UF 40764. Scale bar = 5 mm.

presence of lateral fringes on the digits also distinguishes *E. araiodactylus* from *E. manipus*.

Description.— ($n = 1$ female). Head as wide as body. HW 40.0% SVL; HL 44.0% SVL; Snout moderately long, rounded in dorsal view and in profile (Fig. 14); E-N 89.7% length of eye; nostrils slightly protuberant, directed dorsolaterally; canthus rostralis rounded, slightly curved; loreal region noticeably concave; lips rounded; upper eyelid lacking tubercles; upper eyelid width 71.0% IOD; supratympanic fold moderate; abruptly curving downward behind tympanum, barely obscuring upper edge of tympanum; side of head nearly vertical; tympanic membrane evident; tympanic annulus distinct; length of tympanic annulus 48.3% length of eye; prominent diagonal dermal ridge (possibly coalesced postrictal tubercles) posteroventral to tympanum. Choanae small, round, not concealed by palatal shelf of maxillary arch; vomerine odontophores prominent, oval, widely separated medially, located behind posterior edges of choanae, each odontophore bearing three teeth. Tongue about 1.5 \times as long as wide, not notched posteriorly; posterior half not adherent to floor of mouth.

Skin on dorsum smooth; dorsolateral fold low, extending from level of axilla to groin; skin on flanks pustular, venter smooth, except coarsely areolate on proximal posteroventral surfaces of thighs; discoidal fold prominent; cloacal sheath short; large tubercles in cloacal region absent. Ulnar tubercles absent. Thenar tubercle elevated, elliptical, about twice size of inner palmar tubercle; palmar tubercle elevated, completely divided, outer tubercle about $\frac{1}{2}$ size of inner; palmar supernumerary tubercles absent; subarticular tubercles large, round; fingers bearing lateral fringes; first finger equal in length to second. Discs on Fingers I and II small, round; discs on all fingers narrow, round, barely wider than digit proximal to pad (Fig. 15); Fingers II-IV having ventral pads weakly defined by circumferential grooves. Upper surfaces of hind limbs smooth; heel tarsus lacking tubercles; inner metatarsal tu-

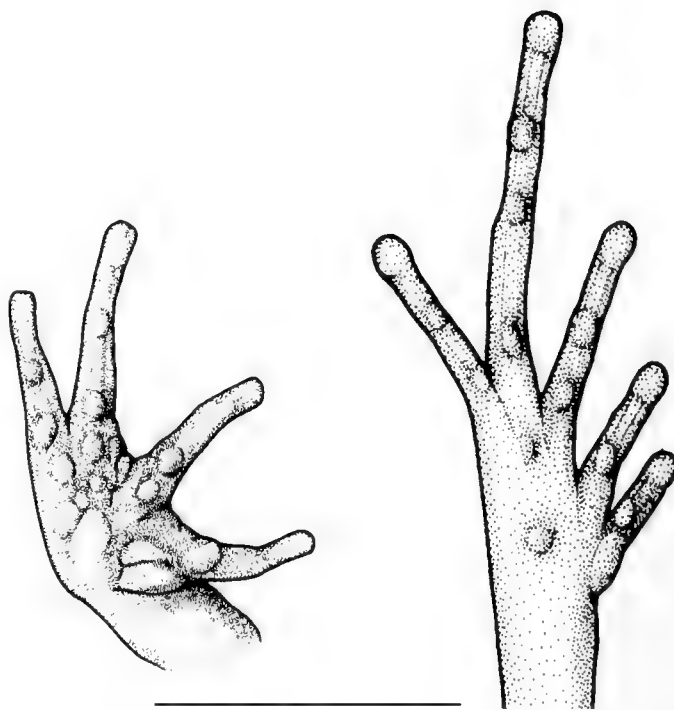

Fig. 15. Hand and foot of *Eleutherodactylus araiodactylus*, UF 40764. Scale = 5 mm.

bercle elevated, elliptical, about 2 \times subconical outer metatarsal tubercle; few plantar supernumerary tubercles on proximal segments of Toes IV and V; subarticular tubercles small, subconical; toes bearing lateral fringes; toes not webbed; discs on toes about equal in size to those on fingers; tips of Toes III and V extending to distal edge of penultimate subarticular tubercle on Toe IV (Fig. 15); when hind limbs flexed perpendicular to axis of body, heels overlap by about $\frac{1}{4}$ length of shank; shank 54.3% SVL.

Coloration in preservative: Dorsum between dorsolateral folds tan with narrow, median cream stripe from snout to vent; on body, stripe bordered by irregular brown markings 2-3 \times width of stripe (Fig. 16). Brown interorbital bar, and canthal and supratympanic stripes present; short, dark brown stripe from upper eyelid extending posteromedially onto occiput; labial bars absent. Flanks brown; groin unmarked; forelimbs tan with two brown spots on inner surface of forearm; hind limbs brown with faint, narrow, darker diagonal marks; venter and posterior surfaces of thighs uniform tan.

Coloration in life: Unknown.

Measurements of holotype: SVL 24.5, tibia length 13.3, foot length 13.5, head width 9.8, head length 9.8, IOD 3.1, upper eyelid width 2.2, E-N 2.6, eye, 2.9, tympanum 1.4.

Distribution and habitat.—*Eleutherodactylus araiodactylus* is known only from 3370 m in very humid

montane forest in the northern part of the Cordillera Central in Peru (Fig. 13).

Etymology.—The specific name derived from the Greek *araios*, meaning thin, and the Greek *daktylos*, meaning finger or toe. The name applies to the extremely slender digits of this species.

Remarks.—This is one of the most distinctive species of *Eleutherodactylus* in northern Peru; consequently, we have no qualms about naming it on the basis of a single specimen. The presence of a middorsal pale stripe is a color polymorphism in many species of *Eleutherodactylus*; its presence in the holotype probably is not indicative of the species.

ELEUTHERODACTYLUS ORESTES GROUP

Inclusion in the *Eleutherodactylus orestes* Group of the four species described herein necessitates a slight modification of the definition of the group as given by Lynch and Duellman (1997). These are that vocal slits and vomerine odontophores are present (*E. orestes*, *simonbolivari*, and *vidua*), absent (*E. melanogaster* and *E. pataikos*), vomerine odontophores absent and vocal slits present (*E. atrabracus*), or vomerine odontophores present and vocal slits unknown (*E. pinguis*). Furthermore, the distribution of the group needs to be changed. Members of the group inhabit high-altitude cloud forests in the Cordillera Occidental in western Ecuador (*E. simonbolivari*), paramo in the southern part of the Cordillera Oriental in Ecuador (*E. orestes* and *E. vidua*), and supra-treeline habitats in the Cordillera Colán (*E. atrabracus*) and the northern parts of the Cordillera Central (*E. melanogaster* and *E. pataikos*) and Cordillera Occidental (*E. pinguis*) in Peru.

Eleutherodactylus atrabracus new species

Holotype.—LSUMZ 49144, adult female from the Cordillera Colán, east of La Peca (05°36' S, 78°22' W, 2963 m), Provincia Bagua, Departamento Amazonas, Peru, obtained on 4 September 1978 by Morris D. Williams.

Paratype.—LSUMZ 45090, adult male from the Cordillera Colán, east of La Peca, 3330 m, obtained on 31 August 1978 by Thomas S. Schulenberg.

Diagnosis.—A member of the *Eleutherodactylus* (*Eleutherodactylus*) *orestes* Group having (1) skin on dorsal surfaces finely shagreen, that on throat, belly, and ventral surfaces of thighs coarsely areolate; discoidal fold weak posteriorly; dorsolateral folds absent; (2) tympanic membrane differentiated, tympanic annulus round; its diameter slightly about ½ length of eye; (3) snout moderately long, bluntly rounded in dorsal view and in profile, inclined anteroventrally from level of nostrils; (4) upper eyelid narrower than IOD, lacking tubercles; cranial crests absent; (5) vomerine odontophores absent; (6) vocal slits present; nuptial excrescences absent; (7) Finger I shorter

than II; discs on outer fingers rounded, barely wider than digit proximal to pad; (8) fingers bearing lateral fringes; (9) ulnar tubercles absent; (10) heel and outer edge of tarsus lacking tubercles; low, thick fold on distal part on inner surface of tarsus; (11) inner metatarsal tubercle elevated, ovoid, about 5× round outer metatarsal tubercle; plantar surfaces coarsely areolate; (12) toes bearing lateral fringes; webbing absent; Toe V slightly longer than III; discs as large as those on outer fingers; (13) dorsum nearly uniform brown; throat and belly creamy tan with fine brown reticulations; ventral surfaces of hind limbs black; groin and anterior surfaces of thighs dark brown with large tan spots; (14) SVL in one adult male 18.9, in one adult female 22.7 mm.

Eleutherodactylus atrabracus differs from all other members of the *E. orestes* Group by having a pale belly and the ventral surfaces of the hind limbs black; furthermore, it differs from *E. pataikos* by having large pale spots in the groin and on the anterior surfaces of the thighs (Fig. 17). *Eleutherodactylus atrabracus* differs from *E. melanogaster* and *E. simonbolivari* by having a pale, instead of black, belly, and from *E. pinguis* by having the ventral surfaces of the hind limbs black and by lacking vomerine teeth. Two other species in the group, *E. orestes* and *E. vidua*, both of which have vomerine odontophores, also have pale spots in the groin; in the latter, the spots are large and lie between diagonal brown bars on the posterior half of the flanks, whereas in *E. vidua*, the groin is black with small white spots.

Description.—(*n* = 1 male, 1 female). Head narrower than body; HW 34.9–36.1 (\bar{x} = 35.5)% SVL; HL 34.9–40.5 (\bar{x} = 37.7)% SVL; snout moderately long, bluntly rounded in dorsal view; in profile, inclined anteroventrally from level of nostrils to margin of lip; E–N 90.0–100.0 (\bar{x} = 95.0)% length of eye; nostrils slightly protuberant, directed laterally; canthus rostralis weakly angular, slightly curved; loreal region noticeably concave; lips rounded; upper eyelid lacking tubercles; upper eyelid width 71.4–84.0 (\bar{x} = 77.7)% IOD; cranial crests absent; supratympanic fold weak, barely obscuring upper edge of tympanum; side of head nearly vertical; tympanic membrane differentiated; tympanic annulus round; length of tympanic annulus 39.1–50.0 (\bar{x} = 44.6)% length of eye; postrictal tubercles low, diffuse. Choanae small, round, not concealed by palatal shelf of maxillary arch; vomerine odontophores absent; tongue much longer than wide, shallowly notched posteriorly, posterior half not adherent to floor of mouth.

Skin on dorsum finely shagreen, that on venter areolate; discoidal fold barely evident posteriorly; dorsolateral folds absent; cloacal sheath short; enlarged tubercles in cloacal region absent. Ulnar tubercles absent; thenar tubercle ovoid, elevated, about half the size of bifid palmar tubercle; supernumerary palmar tubercles round;

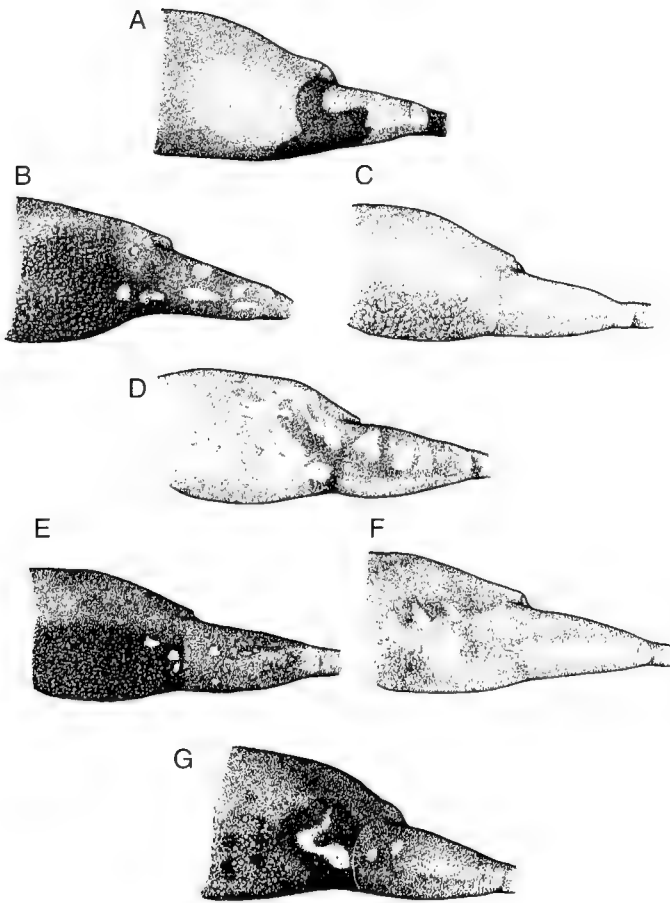

Fig. 17. Color pattern and skin texture in the groin and on the anterior surfaces of the thighs in species in the *Eleutherodactylus orestes* group. A. *E. atrabracus*, LSUMZ 49144. B. *E. melanogaster*, KU 218513. C. *E. pataikos*, KU 212320. D. *E. pinguis*, KU 181283. E. *E. simonbolivari*, KU 218253. F. *E. vidua*, KU 120083. G. *E. orestes*, KU 141999. Not drawn to scale.

subarticular tubercles prominent, round; fingers bearing thick lateral fringes; Finger I shorter than II; discs on all fingers small, only slightly wider than width of digits; all fingers having ventral pads weakly defined by circumferential grooves. Upper surfaces of hind limbs coarsely shagreen; heel and outer edge of tarsus lacking tubercles; inner edge of tarsus bearing low, thick fold distally; inner metatarsal tubercle elevated, ovoid, about 5× round outer metatarsal tubercle; plantar surfaces areolate; subarticular tubercles, round; toes bearing thick lateral fringes; webbing absent; discs on toes about equal in size to those on fingers; tip of Toe V extending to proximal edge of penultimate subarticular tubercle on Toe IV; tip of Toe III not extending to that tubercle; when hind limbs flexed perpendicular to axis of body, heels barely overlapping; shank 38.6–40.5 (\bar{x} = 39.6)% SVL.

Coloration in preservative: Dorsum of head, body, and limbs nearly uniform brown; faint dark brown canthal and

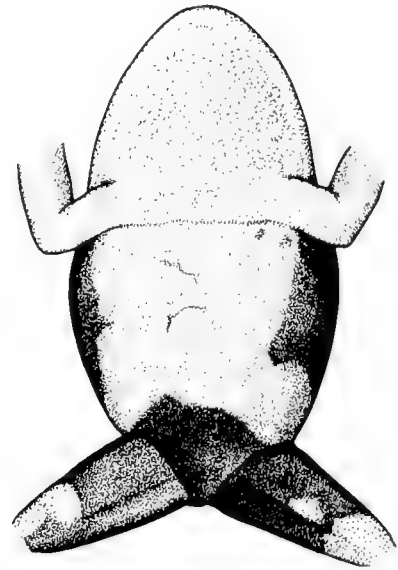

Fig. 18. Ventral color pattern *Eleutherodactylus atrabracus*, LSUMZ 49144. SVL = 22.7 mm.

supratympanic stripes present in both specimens; in female holotype, diffuse brown dorsolateral line and distinct middorsal tan stripe from tip of snout to vent; interorbital bar, labial bars and transverse bars on limbs absent. Groin and anterior surfaces of thighs dark brown with large tan spots (Fig. 17A); throat and belly creamy tan with fine brown reticulations and narrow transverse line in thoracic region; ventral surfaces of hind limbs black (Fig. 18).

Coloration in life: Unknown.

Measurements of holotype: SVL 22.7, tibia length 9.2, foot length 9.5, head width 8.2, head length 9.2, IOD 22.5, upper eyelid width 2.1, E–N 2.3, eye 2.3, tympanum 0.9.

Distribution and habitat.—*Eleutherodactylus atrabracus* is known only from two localities at elevations of 2963 and 3330 m on the western slopes of the Cordillera Colán in northern Peru (Fig. 19). The paratype was in a grassy bog above treeline.

Etymology.—The specific name is derived from the Latin adjective, *atra*, meaning black and the Latin noun, *braca*, meaning trousers, and refers to the black ventral surfaces of the hind limbs in this species.

Eleutherodactylus melanogaster new species

Holotype.—KU 212321, adult female, from the north slope of Abra Barro Negro (06°41' S, 77°51' W, 3470 m), 28 km [by road] SSW Leimebamba, Provincia Chachapoyas, Departamento Amazonas, Peru, one of a series collected on 23 January 1989 by William E. Duellman and John J. Wiens.

Paratypes.—KU 212322–23 and 218513, adult males, collected with the holotype; KU 181281, an adult female,

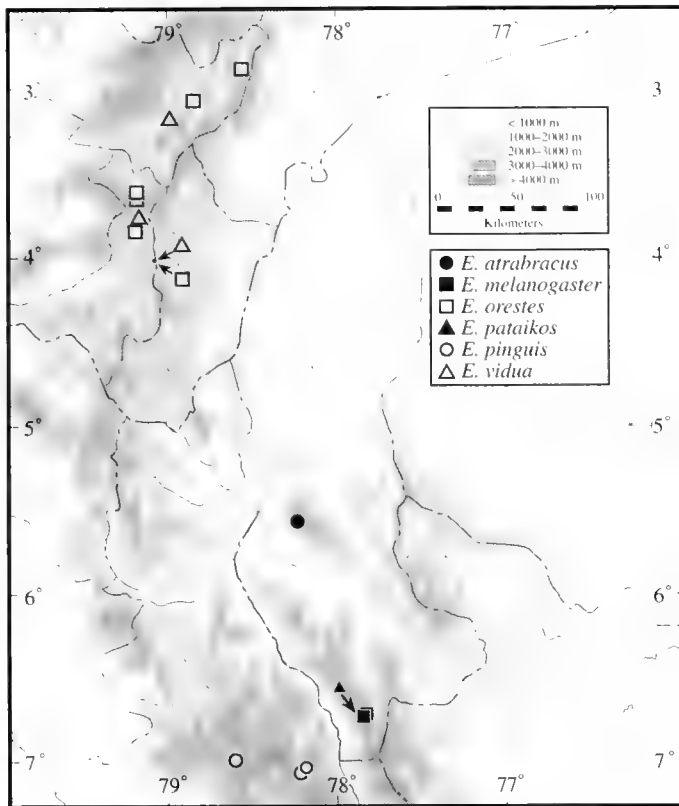

Fig. 19. Localities of known occurrence of six species in the *Eleutherodactylus orestes* group in the Andes of southern Ecuador and northern Peru. Another member of the group, *E. simonbolivari*, occurs farther north in Cordillera Occidental in Ecuador.

from the north slope of Abra Barro Negro, 3300 m, 25.5 km [by road] SSW Leimebamba, Provincia Chachapoyas, Departamento Amazonas, Peru, collected on 6 March 1979 by William E. Duellman.

Diagnosis.—A member of the *Eleutherodactylus orestes* Group having (1) skin on most surfaces coarsely areolate, nearly pustular dorsolaterally; snout, anterior surfaces of thighs and inner surfaces of shanks smooth; discoidal fold weak posteriorly, prominent as transverse thoracic fold anteriorly; dorsolateral folds absent; (2) tympanum indistinct, tympanic annulus round; its diameter about 30% length of eye in males, 60% in females; (3) snout short, rounded in dorsal view and in profile; (4) upper eyelid narrower than IOD, lacking tubercles; cranial crests absent; (5) vomerine odontophores absent; (6) vocal slits and nuptial excrescences absent; (7) Finger I shorter than II; discs on outer fingers rounded, barely wider than digit proximal to pad; (8) fingers lacking lateral fringes; (9) ulnar tubercles absent; (10) heel and outer edge of tarsus lacking tubercles; inner edge of tarsus bearing low, indistinct fold distally; (11) inner metatarsal tubercle elevated, ovoid, about 3× round outer metatarsal tubercle;

plantar surfaces areolate; (12) toes lacking lateral fringes; webbing absent; Toe V slightly longer than III; discs as large as those on outer fingers; (13) dorsum and venter black with or without pale spots in groin and on anterior and posterior surfaces of thighs and inner surfaces of shanks; (14) SVL in three adult males 20.6–22.8 (\bar{x} = 21.9 mm), in two adult females, 24.2–24.7 (\bar{x} = 24.5 mm).

Eleutherodactylus melanogaster differs from all other members of the *E. orestes* Group by having the skin on the dorsum coarsely areolate and by being black dorsally and ventrally. With the exception of the nature of the skin on the dorsum, *E. melanogaster* most resembles the smaller *E. simonbolivari*, which also has pale spots in the groin and on the hidden surfaces of the hind limbs, but *E. simonbolivari* has vomerine odontophores and a small, nonconical tubercle on the heel. *Eleutherodactylus orestes* and *E. pinguis* also have pale spots in the groin and on the posterior surfaces of the thighs, but the skin on the dorsum is finely tuberculate, the dorsum is brown with darker brown markings, vomerine odontophores are present, and there is a small, nonconical tubercle on the heel in *E. simonbolivari*. The sympatric *E. pataikos* is like *E. melanogaster* in lacking vomerine odontophores and a tubercle on the heel, but it differs by having a smooth dorsum that is pale brown and by lacking markings in the groin and on the posterior surfaces of the thighs. *Eleutherodactylus atrabracus* also lacks vomerine teeth, but it has a finely shagreen dorsum, a pale belly, and black ventral surfaces of the hind limbs.

Description.—(n = 3 males, 2 females; proportions are for males with followed those of by females). Head narrower than body; HW 36.0–38.3 (\bar{x} = 36.9), 39.2–39.4 (\bar{x} = 39.3)% SVL; HL 33.8–36.4 (\bar{x} = 35.1), 36.4–37.2 (\bar{x} = 36.8)% SVL; snout short, rounded in dorsal view, and in profile; E–N 64.0–71.4 (\bar{x} = 67.8), 80.0–83.0 (\bar{x} = 81.5) % length of eye; nostrils slightly protuberant, directed dorsolaterally; canthus rostralis rounded, curved; loreal region weakly concave; lips rounded; upper eyelid lacking tubercles; upper eyelid width 68.0–71.4 (\bar{x} = 70.3), 75.9–76.7 (\bar{x} = 76.3)% IOD; cranial crests absent; supratympanic fold a series of pustular granules, obscuring upper edge of tympanum; side of head nearly vertical; tympanum indistinct; tympanic annulus thin; tympanic membrane thickened; tympanic annulus round; length of tympanic annulus 33.3–44.0% (37.8), 60.0–66.7 (63.3) % length of eye; postrictal tubercles not discernible from other pustules; skin on top of head smooth. Choanae small, round, not concealed by palatal shelf of maxillary arch; vomerine odontophores absent; tongue much longer than wide, not notched posteriorly, posterior half not adherent to floor of mouth. Males lacking vocal slits and nuptial excrescences.

Skin on dorsum coarsely areolate, especially dorsolaterally; that on venter coarsely areolate; discoidal

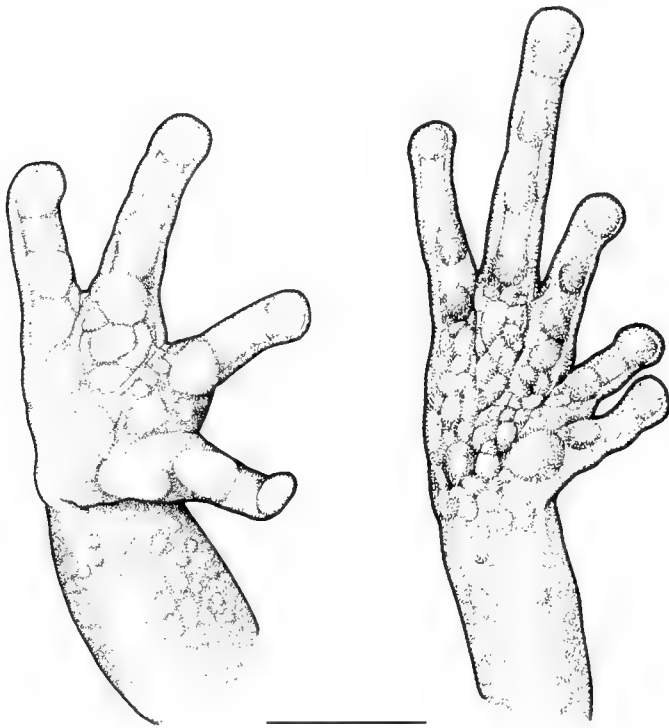

Fig. 20. Hand and foot of *Eleutherodactylus melanogaster*, KU 212321. Scale = 5 mm.

fold barely evident posteriorly, present as distinct transverse thoracic fold anteriorly; dorsolateral folds absent; flanks coarsely areolate; cloacal sheath short; enlarged tubercles in cloacal region absent. Ulnar tubercles not distinguishable; thenar tubercle ovoid, slightly elevated, about as large as ovoid palmar tubercle; supernumerary palmar tubercles not evident; subarticular tubercles prominent, round; fingers lacking lateral fringes; first finger shorter than second; discs on all fingers small, only slightly wider than width of digits (Fig. 20); all fingers having ventral pads weakly defined by circumferential grooves. Upper surfaces of hind limbs coarsely areolate; heel and outer edge of tarsus lacking tubercles; inner edge of tarsus with low fold distally; inner metatarsal tubercle elevated, ovoid, about 3× round outer metatarsal tubercle; plantar surfaces areolate; subarticular tubercles large, round; toes lacking lateral fringes; webbing absent; discs on toes about equal in size to those on fingers; tip of Toe V extending to point midway between penultimate and distal subarticular tubercles on Toe IV; tip of Toe III extending to distal edge of penultimate tubercle on Toe IV (Fig. 20); when hind limbs flexed perpendicular to axis of body, heels not overlapping; shank 36.4–39.3 \bar{x} = 37.5), 37.1–37.7 (\bar{x} = 37.4) % SVL.

Coloration in preservative: Female holotype and one male (KU 212323) black above and below with small, dif-

fuse white spots in groin, on anterior and posterior surfaces of thighs (Fig. 17B), and on inner surfaces of shanks; spots absent in other female (KU 181281) and in two males (KU 212322, 218513).

Coloration in life: KU 212321: Dorsum dull brown with creamy tan canthal stripe bordered below by black line (Fig. 9); black postocular stripe; belly dark gray; axilla, groin, and ventral surfaces of limbs black with bright yellow spots; iris pale gold with black flecks (WED field notes, 23 January 1989).

Measurements of holotype: SVL 24.7, tibia length 9.3, foot length 10.5, head width 9.7, head length 9.0, IOD 3.0, upper eyelid width 2.3, E–N 2.0, eye 2.4, tympanum 1.6.

Distribution and habitat.—*Eleutherodactylus melanogaster* is known only from two localities at elevations of 3300 and 3470 m, respectively, on the road from Balsas to Leimebamba, near the crest of the northern part of the Cordillera Central in northern Peru (Fig. 19). All individuals were under stones by day; those from 3470 m were in wet paramo, whereas the individual from 3300 m was in elfin forest; both habitats fall within the very humid montane forest

Etymology.—The specific name is derived from the Greek adjective *melanos* meaning black and the Green noun *gaster* meaning belly; the name is used in reference to the uniformly black ventral coloration.

Eleutherodactylus pataikos new species

Holotype.—KU 212320, adult female, from the north slope of Abra Barro Negro, (06°41' S, 77°51' W, 3470 m), 28 km [by road] SSW Leimebamba, Provincia Chachapoyas, Departamento Amazonas, Peru, obtained on 23 January 1989 by William E. Duellman.

Diagnosis.—A member of the *Eleutherodactylus* (*Eleutherodactylus*) *orestes* Group having (1) skin on dorsum smooth with few low tubercles dorsolaterally and on hind limbs, that on venter coarsely areolate; discoidal fold weak; dorsolateral folds absent; (2) tympanum indistinct, tympanic annulus distinguishable anteroventrally, round; its diameter less than ½ length of eye; (3) snout short, rounded in dorsal view and in profile; (4) upper eyelid narrower than IOD, lacking tubercles; cranial crests absent; (5) vomerine odontophores absent; (6) condition of vocal slits and nuptial excrescences unknown; (7) Finger I shorter than II; discs on outer fingers rounded, barely wider than digit proximal to pad; (8) fingers lacking lateral fringes; (9) ulnar tubercles absent; (10) heel and outer edge of tarsus lacking tubercles; inner edge of tarsus bearing single, low tubercle; (11) inner metatarsal tubercle flat, ovoid about 4× round outer metatarsal tubercle; supernumerary tubercles low, diffuse; (12) toes lacking lateral fringes; webbing absent; Toe V slightly longer than III; discs as large as

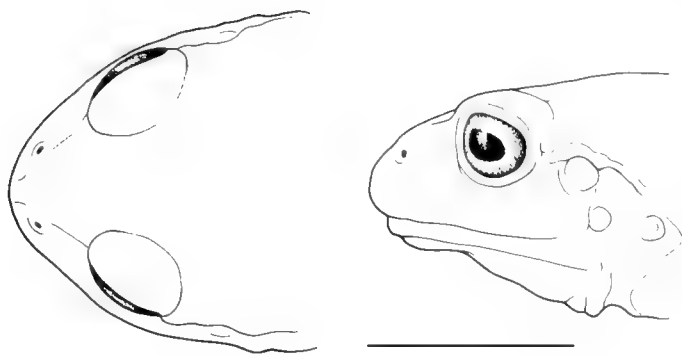

Fig. 21. Dorsal and lateral views of the head of *Eleutherodactylus pataikos*, KU 212320. Scale bar = 5 mm.

those on outer fingers; (13) dorsum uniform pale brown; venter tan; posterior surfaces of thighs brown; (14) SVL in one adult female 21.6 mm.

Eleutherodactylus pataikos differs from other members of the *E. orestes* Group by lacking distinctive markings. *Eleutherodactylus atrabracus*, *orestes*, *pinguis*, *simonbolivari*, and *melanogaster* have large pale spots in the groin, and the latter, which occurs sympatrically with *E. pataikos*, has coarsely areolate skin on the dorsum, which, like the venter, is black. *Eleutherodactylus pinguis* and *E. atrabracus* also differ by having a prominent tympanum and tympanic annulus; the former also differs by having the ulnar tubercles coalesced into a fold, and the latter also differs by having a pale belly and black ventral surfaces of the hind limbs. *Eleutherodactylus orestes* and *E. vidua* have cream spots at least distally on the posterior surfaces of the thighs, which are uniform pale brown in *E. pataikos*; the latter (*E. pataikos*) also differs by lacking vomerine odontophores, a feature shared only with *E. atrabracus* and *E. melanogaster* in the *E. orestes* Group.

Description.—($n = 1$ female). Head narrower than body; HW 39.4% SVL HL 36.1 % SVL; snout short, rounded in dorsal view, and in profile (Fig. 21); E–N 71.4% length of eye; nostrils slightly protuberant, directed dorsolaterally; canthus rostralis rounded, nearly straight; loreal region weakly concave; lips rounded; upper eyelid lacking tubercles; upper eyelid width 70.8% IOD; cranial crests absent; supratympanic fold diffuse, obscuring upper edge of tympanum; side of head nearly vertical; tympanic annulus thin, evident only anteroventrally; tympanic membrane not pustular or thickened; tympanic annulus round; length of tympanic annulus 33.3% length of eye; two large, round postrictal tubercles, posteroventral to tympanic annulus; skin on head smooth. Choanae small, round, not concealed by palatal shelf of maxillary arch; vomerine odontophores absent; tongue much longer than wide, not

notched posteriorly, posterior half not adherent to floor of mouth. Males unknown.

Skin on dorsum smooth with few low tubercles dorsolaterally and on hind limbs, that on venter coarsely areolate; discoidal fold weak; dorsolateral folds absent; flanks tuberculate; cloacal sheath short and enlarged tubercles in cloacal region absent; skin on throat smooth, on belly coarsely granular; discoidal fold weak. Ulnar tubercles absent; thenar tubercle ovoid, flat, about as large as ovoid palmar tubercle; supernumerary palmar tubercles few, large, round; subarticular tubercles prominent, round; fingers lacking lateral fringes; Finger I shorter than II; discs on all fingers small, only slightly wider than width of digits; all fingers having ventral pads weakly defined by circumferential grooves. Upper surfaces of hind limbs smooth with scattered small tubercles; heel and outer edge of tarsus lacking tubercles; inner edge of tarsus bearing small, indistinct tubercle; inner metatarsal tubercle flat, ovoid about 4× round outer metatarsal tubercle; supernumerary tubercles low, diffuse; subarticular tubercles large, round; toes lacking lateral fringes; webbing absent; discs on toes about equal in size to those on fingers; tip of Toe V extending to point midway between penultimate and distal subarticular tubercles on Toe IV; tip of Toe III extending to distal edge of penultimate tubercle on Toe IV; when hind limbs flexed perpendicular to axis of body, heels not overlapping; shank 37.0% SVL.

Coloration in preservative: Dorsum, flanks and hidden surfaces of limbs dull, pale brown; venter, dull tan. No markings evident (Fig. 17C).

Coloration in life: Dorsum pale brown with narrow, diffuse cream stripe on canthus and outer edge of eyelid, and narrow, dark brown supratympanic stripe (Fig. 9); venter creamy gray; groin dark gray; iris dull bronze with black flecks.

Measurements of holotype: SVL 21.6, tibia length 8.0, foot length 8.8, head width 8.5, head length 7.8, IOD 2.4, upper eyelid width 1.7, E–N 1.5, eye 2.1, tympanum 0.7.

Distribution and habitat.—The species is known only from one locality at 3470 m on the road from Balsas to Leimebamba, near the crest of the northern part of the Cordillera Central in northern Peru (Fig. 19). The only known specimen, an adult female, was under a rock in very humid montane forest by day.

Etymology.—The specific name *pataikos* is a Greek noun in apposition for an odd-shaped dwarflike Phoenician deity. The name refers to the small but Rubenesque stature of this frog.

Remarks.—Loath though we are to describe a new species of *Eleutherodactylus* from a single specimen, this individual certainly is distinctive in the *Eleutherodactylus orestes* Group.

Eleutherodactylus pinguis new species

Holotype.—KU 181283, an adult female from 23 km [by road] SW Celendín (06°58' S, 78°06' W, 3050 m), Provincia Celendín, Departamento Cajamarca, Peru, one of a series collected by David C. Cannatella, William E. Duellman, and Thomas J. Berger on 8 March 1979.

Paratypes.—KU 181282 collected with the holotype, and KU 181284 from 33 km [by road] SW Celendín, 3200 m, Provincia Celendín, Departamento Cajamarca, Peru.

Referred specimen.—UF 40766 from 57 km [by road] N Cajamarca, 3760 m, Provincia Cajamarca, Departamento Cajamarca, Peru.

Diagnosis.—A member of the *Eleutherodactylus* (*Eleutherodactylus*) *orestes* Group having (1) skin on dorsal surfaces finely areolate, that on throat, belly, and ventral surfaces of thighs coarsely areolate; discoidal fold weak posteriorly, prominent as transverse thoracic fold anteriorly; dorsolateral folds absent; (2) tympanum membrane differentiated, tympanic annulus round; its diameter slightly more than $\frac{1}{2}$ length of eye; (3) snout moderately long, acutely rounded in dorsal view and bluntly rounded in profile; (4) upper eyelid narrower than IOD, lacking tubercles; cranial crests absent; (5) vomerine odontophores prominent, oblique; (6) condition of vocal slits and nuptial excrescences unknown; (7) Finger I shorter than II; discs on outer fingers rounded, barely wider than digit proximal to pad; (8) fingers lacking lateral fringes; (9) ulnar tubercles coalesced into short fold; (10) heel and outer edge of tarsus lacking tubercles; low, thick fold on distal part on inner surface of tarsus; (11) inner metatarsal tubercle flat, ovoid, about 3 \times subconical outer metatarsal tubercle; plantar surfaces coarsely areolate; (12) toes bearing lateral fringes; webbing absent; Toe V slightly longer than III; discs as large as those on outer fingers; (13) dorsum brown; venter tan with brown flecks or reticulations; groin and proximal anterior surfaces of thighs dark brown with large cream spots; (14) SVL in three adult females 28.4–29.8 (\bar{x} = 28.9 mm).

Eleutherodactylus pinguis differs from other members of the *E. orestes* Group by having the ulnar tubercles coalesced into a low fold; it differs from *E. melanogaster* and *E. simonbolivari* by having a pale, as opposed to a dark, venter, and from *E. atrabracus*, *melanogaster*, and *pataikos* by having vomerine teeth. *Eleutherodactylus pinguis* also differs from *E. pataikos* by having a prominent tympanum and tympanic annulus and distinctive markings in the groin and pale spots on the posterior surfaces of thighs, which are uniform pale brown in *E. pataikos*. Two other species in the group, *E. orestes* and *E. vidua*, also have pale spots in the groin; in the latter, the spots are large and lie between diagonal brown bars on the posterior half of the flanks,

whereas in *E. vidua*, the groin is black with small white spots.

Description.—(n = 3 females). Head narrower than body; HW 36.5–38.0 (\bar{x} = 37.1)% SVL; HL 34.2–36.1 (\bar{x} = 35.1)% SVL; snout moderately long, acutely rounded in dorsal view, and bluntly rounded in profile; E–N 75.9–92.8 (\bar{x} = 83.0)% length of eye; nostrils slightly protuberant, directed dorsolaterally; canthus rostralis weakly angular, slightly curved; loreal region noticeably concave; lips rounded; upper eyelid lacking tubercles; upper eyelid width 56.4–65.7 (\bar{x} = 59.7)% IOD; cranial crests absent; supratympanic fold weak, granular, obscuring upper edge of tympanum; side of head nearly inclined ventrolaterally; tympanic membrane weakly differentiated; tympanic annulus round; length of tympanic annulus 53.6–55.2 (\bar{x} = 54.6)% length of eye; postrictal tubercles not discernible from other tubercles. Choanae small, round, not concealed by palatal shelf of maxillary arch; vomerine odontophores prominent, oval in outline, oblique, widely separated medially, located behind posterior edges of choanae, each odontophore bearing 3 or 4 (\bar{x} = 3.8 teeth); tongue much longer than wide, shallowly notched posteriorly, posterior half not adherent to floor of mouth. Males unknown.

Skin on dorsum finely areolate, more coarsely areolate laterally; that on venter coarsely areolate; discoidal fold barely evident posteriorly, present as distinct transverse thoracic fold anteriorly; dorsolateral folds absent; cloacal sheath short; enlarged tubercles in cloacal region absent. Ulnar tubercles coalesced so as to form low ridge distally on forearm; thenar tubercle ovoid, slightly elevated, somewhat smaller than bifurcate palmar tubercle; supernumerary palmar tubercles not evident; subarticular tubercles prominent, round; fingers bearing thick lateral fringes; Finger I shorter than II; discs on all fingers small, only slightly wider than width of digits; all fingers having ventral pads weakly defined by circumferential grooves. Upper surfaces of hind limbs coarsely areolate; heel and outer edge of tarsus lacking tubercles; inner edge of tarsus bearing low, thick fold distally; inner metatarsal tubercle flat, ovoid, about 3 \times subconical outer metatarsal tubercle; plantar surfaces areolate; subarticular tubercles large, round; toes bearing thick lateral fringes; webbing absent; discs on toes about equal in size to those on fingers; tip of Toe V extending to distal edge of penultimate subarticular tubercle on Toe IV; tip of Toe III not extending to that tubercle; when hind limbs flexed perpendicular to axis of body, heels not overlapping; shank 35.4–40.4 (\bar{x} = 38.1)% SVL.

Coloration in preservative: Dorsum of head, body, and limbs brown with faintly darker brown markings (absent in KU 181284); markings consisting of faint interorbital mark, numerous small irregular flecks on body and faint

diagonal crossbar on shank. Dark brown markings in groin and on proximal anterior surfaces of thighs, nearly enclosing large cream spots (Fig. 17D); distal portion of posterior surfaces of thighs and inner surfaces of shanks cream with large, dark brown markings. Venter creamy tan with minute brown flecks on throat and belly in KU 181282, larger clusters of flecks, especially on belly, in KU 181283, and fine brown reticulations in KU 181284.

Coloration in life: KU 181284: Dorsum dull red becoming dull green on upper flanks; venter dull yellow reticulated with grayish brown; iris dull reddish bronze (Fig. 9; WED field notes, 08 March 1989).

Measurements of holotype: SVL 28.4, tibia length 10.7, foot length 11.4, head width 10.8, head length 9.7, IOD 3.5, upper eyelid width 2.2, E–N 2.2, eye 2.9, tympanum 1.6.

Distribution and habitat.—*Eleutherodactylus pinguis* is known from three localities in the northern part of the Cordillera Occidental in Peru (Fig. 19). Two localities are at elevations of 3050 and 3200 m on the road between Cajamarca and Celendín, on the eastern slopes of Abra Comulica. All individuals were under stones by day. Those from 3050 m were in a wet grassy area, whereas the individual from 3200 m was in a bunch grass–*Baccharis* association. Another specimen is from an elevation of 3760 m north of Cajamarca; it was under a rock in a grassy region by day.

Etymology.—The specific name is a Latin adjective meaning fat; the name refers to the corpulent habitus of this species.

Remarks.—A subadult female (UF 40766) having a snout-vent length of 24.0 mm is like the type series in structural features. The color pattern is faded, so there are no markings evident in the groin or on the thighs; no dark flecks are present on the venter.

ELEUTHERODACTYLUS UNISTRIGATUS GROUP

As noted by Lynch and Duellman (1997), members of this group are characterized by areolate skin on the venter and Toe V being much longer than Toe III. This is the largest group of *Eleutherodactylus* and now contains more than 175 species, of which 31 are known from the Andes in northern Peru.

Eleutherodactylus acuminatus Shreve

Eleutherodactylus acuminatus Shreve, 1935:217. Holotype, MCZ 19951 from Canelos, Provincia Pastaza, Ecuador.

Diagnosis.—A member of the *Eleutherodactylus* (*Eleutherodactylus*) *unistrigatus* Group having (1) skin on dorsum smooth, that on belly and proximal posteroventral surfaces of thighs coarsely areolate; skin on other ventral surfaces smooth; discoidal fold barely evident posteriorly; dorsolateral folds absent; (2) tympanic membrane not differentiated; tympanic annulus distinguishable under skin,

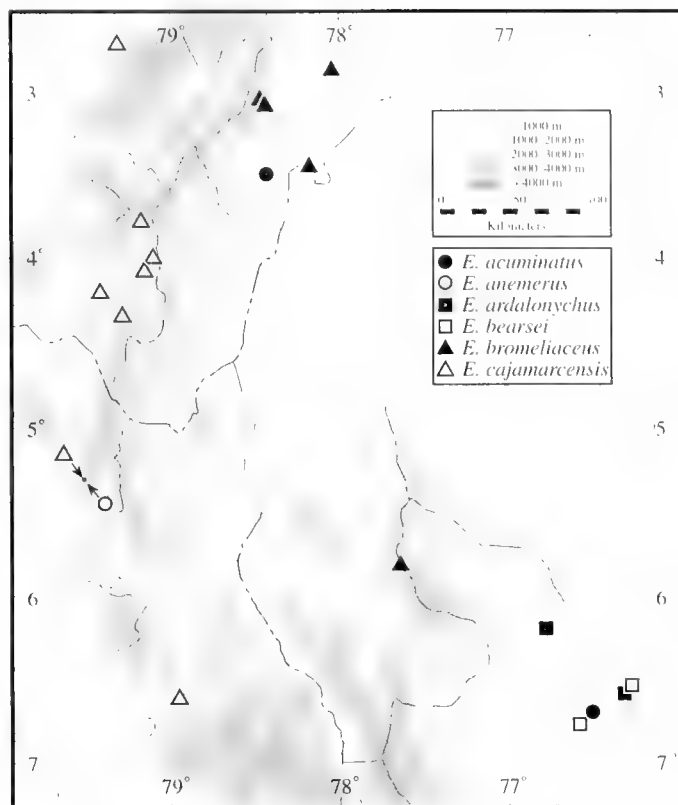

Fig. 22. Localities of known occurrence of six species in the *Eleutherodactylus unistrigatus* group in the Andes of southern Ecuador and northern Peru.

round, its length less than $\frac{1}{2}$ length of eye; (3) snout long, acuminate in dorsal view, truncate and posteriorly inclined in profile; (4) upper eyelid lacking tubercles, much narrower than IOD; cranial crests absent; (5) vomerine odontophores low, ovoid; (6) males lacking vocal slits and nuptial pads; (7) Finger I shorter than II; discs on outer fingers elliptical; (8) fingers lacking lateral fringes; (9) ulnar tubercles absent; (10) heel lacking tubercles; outer edge of tarsus bearing two or three low subconical tubercles; inner edge of tarsus lacking tubercles or fold; (11) inner metatarsal tubercle elevated, elliptical, about 4 \times conical outer metatarsal tubercle; plantar supernumerary tubercles absent; (12) toes lacking lateral fringes; webbing absent; Toe V much longer than III; discs nearly as large as those on outer fingers; (13) dorsum creamy tan (green in life) with black canthal and supratympanic stripes and narrow interorbital bar; limb bars absent; venter and hidden surfaces of thighs cream; (14) SVL in males 17.1–22.6 mm, in females 25.6–31.3 (Lynch, 1980).

This nearly uniformly green species with an acuminate snout, broad head, and concealed tympana is readily distinguished from all other members of the genus in the region. The only other predominately green species is *E. galdi*,

which has flared lips, cranial crests, distinct tympanum, large truncate discs, conical tubercles along the tarsus, and bars on the limbs.

Description.—The description by Shreve (1935) was augmented by Duellman (1978c).

Distribution and habitat.—This primarily Amazonian species invades the lower reaches of the Andes in southern Ecuador and northern Peru. It is known from San José, 830 m, Provincia Morona-Santiago, Ecuador (KU 147976) on the western slopes of the Cordillera del Cóndor and from 15.4 km [by road] SW Zapateros, 950 m, Provincia Lamas, Departamento San Martín, Peru (KU 217308–10) on the eastern slopes of the Cordillera Central (Fig. 22). The latter were in arboreal bromeliads by day.

Remarks.—Two of the specimens from the Cordillera Central are males with SVLs of 21.3 and 21.5 mm; the other is a female having a SVL of 24.3 mm. Although this species is abundant in the lowland rainforest in Amazonian Ecuador, it has been reported only twice from Amazonian Peru—Río Aguayita, Departamento Loreto (Lynch, 1980), and San Jacinto, Departamento Loreto (Duellman and Mendelson, 1995). Additional records are from Departamento San Martín—Río Cainarache, 330 m, 33 km [by road] NE Tarapoto (KU 209466), and Río Shilcayo, 500 m, near Tarapoto (KU 209467).

Eleutherodactylus anemerus new species

Holotype.—KU 219798, adult male, from El Tambo (05°21' S, 79°33' W, 2770 m, 31 km [by road] ENE of Canchaque, Provincia Huancabamba, Departamento Piura, Peru, obtained on 9 January 1991 by Erik R. Wild.

Diagnosis.—A member of the *Eleutherodactylus* (*Eleutherodactylus*) *unistrigatus* Group having (1) skin on dorsum finely tuberculate, that on venter areolate; discoidal fold prominent; dorsolateral folds absent; (2) tympanic membrane and tympanic annulus prominent, round, its length slightly more than ½ length of eye; (3) snout short, acuminate in dorsal view, truncate and posteriorly inclined in profile; tubercle on tip of snout; canthus rostralis rounded; (4) upper eyelid lacking tubercles, narrower than IOD; cranial crests absent; (5) vomerine odontophores absent; (6) males having vocal slits but lacking nuptial pads; (7) Finger I shorter than II; discs moderately small, nearly truncate; (8) fingers bearing narrow lateral fringes; (9) ulnar tubercles low, diffuse; (10) heel lacking tubercles; outer edge of tarsus bearing low tubercles; inner edge of tarsus lacking tubercles or fold; (11) inner metatarsal tubercle broadly ovoid, about 5× subconical outer metatarsal tubercle; plantar supernumerary tubercles few, basal only; (12) toes bearing narrow lateral fringes; webbing absent; Toe V much longer than III; discs about equal in size to those on outer fingers; (13) dorsum uniform, yellowish tan; venter creamy white with minute black flecks; (14) SVL in male 20.4 mm.

lowish tan; venter creamy white with minute black flecks; (14) SVL in male 20.4 mm.

No other species of *Eleutherodactylus* in the region has an unmarked orange-red dorsum and yellow flanks. The dorsal coloration is reminiscent of some individuals of *E. chalceus*, a member of the *Eleutherodactylus diastema* Group in Chococoan Colombia and Ecuador. (See Lynch and Duellman, 1997:plate 8.) However, *E. chalceus* differs from *E. anemerus* in a number of features—areolate skin on the dorsum, absence of a tympanum, papillate discs on the fingers, and Toe V shorter than Toe III. Five other species of *Eleutherodactylus* in the Andes of northern Peru lack vomerine odontophores; three of these (*E. atrabracus*, *melanogaster*, and *pataikos*) robust-bodied members of the *E. orestes* Group that have small terminal discs on the fingers, short hind limbs, and Toe V only slightly longer than Toe III. The other two (*E. incomptus* and *E. percnopterus*) are members of the *E. unistrigatus* Group and have distinctive dark markings on the dorsum.

Description.—($n = 1$ male). Head as wide as body; HW 36.3% SVL; HL 35.3% SVL. Snout moderately short, acuminate in dorsal view, truncate and slightly incline posteroventrally in profile, with subconical tubercle on tip; E–N = length of eye; nostrils noticeably protuberant, directed dorsolaterally; canthus rostralis rounded, slightly curved; loreal region weakly concave; lips rounded; upper eyelid width 77.0% IOD, lacking tubercle; cranial crests absent; supratympanic fold weak, obscuring upper edge of tympanic annulus; side of head inclined ventrolaterally; tympanic membrane present; tympanic annulus round; length of tympanic annulus 55.0% length of eye; three small, subconical poststrictal tubercles below and posteroventral to tympanum. Choanae small, round, not concealed by palatal shelf of maxillary arch; vomerine odontophores absent; tongue nearly twice as long as wide, distinctly notched posteriorly posterior half not adherent to floor of mouth; vocal slits small, extending posterolaterally from lateral base of tongue; vocal sac single, median, subgular.

Skin on dorsum finely tuberculate; dorsolateral fold absent; skin on throat, belly, and ventral surfaces of thighs areolate; skin on other ventral surfaces smooth; discoidal fold prominent; cloacal sheath short; large tubercles in anal region absent. Ulnar tubercles low, diffuse; thenar tubercle elevated, elliptical, slightly larger than bifurcate palmar tubercle; palmar supernumerary tubercles absent; subarticular tubercles moderately small, round; fingers bearing narrow lateral fringes; first finger shorter than second; discs on fingers nearly truncate, nearly 1½× width of digit proximal to pad; all fingers having ventral pads well defined by circumferential grooves. Upper surfaces of hind limbs smooth with small tubercles; heel lacking

tubercle; outer edge of tarsus bearing low tubercles; inner edge of tarsus lacking tubercles or fold; inner metatarsal tubercle elevated broadly ovoid, about 5× subconical outer metatarsal tubercle; plantar supernumerary tubercles few, basal; discs on toes about equal in size to those on fingers; toes bearing narrow lateral fringes; toes unwebbed; tip of Toe V extending to distal edge of distal subarticular tubercle on Toe IV; tip of Toe III extending to middle of penultimate subarticular tubercle on Toe IV; when hind limbs flexed perpendicular to axis of body, heels broadly overlapping; shank 52.5% SVL.

Coloration in preservative: Dorsum uniform tan; canthal and supratympanic stripes, labial and interorbital bars, and transverse marks on limbs absent; venter creamy tan with minute black flecks on throat and belly.

Coloration in life: Dorsum of head, body, and limbs orange-red; flanks, ventral surfaces of limbs, upper lips, loreal region, tympanum, and vocal sac yellow; rest of venter cream; tubercles on dorsum, flanks, and venter white; iris bronze with black reticulations and median, horizontal red streak (Fig. 9; Erik R. Wild, field notes, 8 January 1991).

Measurements of holotype: SVL 20.4, tibia length 10.7, foot length 9.9, head width 7.5, head length 7.2, IOD 2.6, eyelid width 2.0, E–N 2.0, eye 2.0, tympanum 1.1.

Distribution and habitat.—This species is known only from 2770 m in humid montane forest on the western slopes of the Cordillera de Huancabamba (Fig. 22). The male was calling from a red leaf 0.5 m above the ground at night.

Etymology.—The specific epithet is a Greek adjective, *anemeros*, meaning wild. The name is used in reference to Erik R. Wild, collector of the only known specimen.

Remarks.—Duellman and Wild (1993) recognized this species as being distinct from others in the Cordillera de Huancabamba and were reluctant to name the species on the basis of a single specimen. After our review of the *Eleutherodactylus* of the Andes of northern Peru, we are convinced that the specimen cannot be associated with any species described previously.

Eleutherodactylus ardalonychus new species

Holotype.—KU 212301, an adult female, from the Río Cerranayacu (05°46' S, 77°27' W, 1200 m), 76 km [by road] NW Rioja, Provincia Rioja, Departamento San Martín, Peru, obtained on 2 February 1989 by William E. Duellman.

Paratypes.—KU 212299, adult male, from the west slope of Abra Tangarana, 1080 m, 7 km NE [by road] San Juan de Pacaysapa, Provincia Lamas, Departamento San Martín, Peru; KU 212300, adult male, from 8 km [by road] NE Tarapoto, 680 m, Provincia San Martín, Departamento San Martín, Peru.

Referred specimen.—KU 212310, juvenile, from the type locality.

Diagnosis.—A member of the *Eleutherodactylus* (*Eleutherodactylus*) *unistrigatus* Group having (1) skin on dorsum smooth with scattered low tubercles on posterior part of body, that on venter weakly areolate; discoidal fold barely evident posteriorly; dorsolateral folds absent; (2) tympanic membrane not differentiated; tympanic annulus distinguishable under skin, round, its diameter about ½ length of eye; (3) snout long, rounded in dorsal view and in profile; (4) upper eyelid narrower than IOD, lacking tubercles; cranial crests absent; (5) vomerine odontophores low, ovoid; (6) males having vocal slits and unpigmented nuptial pads; (7) Finger I shorter than II; discs on outer fingers rounded, about twice width of digit proximal to pad; (8) fingers bearing narrow lateral fringes; (9) ulnar tubercles absent; (10) heel and outer edge of tarsus lacking tubercles; inner edge of tarsus bearing low, elongate tubercle; (11) inner metatarsal tubercle elevated, elliptical, about 10× low, round outer metatarsal tubercle; supernumerary plantar tubercles numerous; (12) toes bearing narrow lateral fringes; webbing absent; Toe V much longer than III; discs nearly as large as those on outer fingers; (13) dorsum brown with darker brown markings; venter tan with dark brown flecks or reticulations; posterior surfaces of thighs brown, with or without cream flecks or mottling; (14) SVL in two adult males 19.7 and 21.9 mm and an adult female 27.4 mm.

The only other species in the region that can be confused with *Eleutherodactylus ardalonychus* is *E. versicolor*, which also has diagonal bars on the flanks and brown reticulations on the venter, but the reticulations are much coarser than those in *E. ardalonychus*. Furthermore, *E. versicolor* differs by having a shagreen dorsum with scattered fine tubercles, a prominent tympanum, and elliptical, instead of rounded, discs on the outer fingers.

Description.—($n = 2$ males, 1 female; proportions are for the males with mean in parentheses, followed by those of the female). Head noticeably wider than body; HW 37.4–38.1 ($\bar{x} = 37.8$), 38.0% SVL; HL 38.4–39.1 ($\bar{x} = 38.8$), 39.1% SVL; snout long, rounded in dorsal view and in profile; E–N 92.3–100.0 ($\bar{x} = 96.2$), 96.8% length of eye; nostrils slightly protuberant, directed laterally; canthus rostralis rounded, nearly straight; loreal region concave; lips not flared; upper eyelid with lacking tubercles; upper eyelid width 73.9–76.0 ($\bar{x} = 75.0$), 70.8% IOD; cranial crests absent; supratympanic fold weak, not obscuring upper edge of tympanic annulus; side of head nearly vertical; tympanic annulus thin; tympanic membrane not pustular or thickened; tympanic annulus round; diameter of tympanic annulus 40.0, 41.7% length of eye; single, enlarged postrictal tubercle, posteroventral to tympanic annulus; skin on head smooth except for single, rounded tubercle

between orbits in KU 212301; choanae large, nearly round, not concealed by palatal shelf of maxillary arch; vomerine odontophores, low, oblique, posteromedian to choanae, oval in outline, each slightly smaller than choanae, separated medially by distance greater than width of odontophore, bearing 2-2 or 2-3 teeth in males, 3-4 in female; tongue longer than wide, its posterior border shallowly notched, posterior half not adherent to floor of mouth. Male with vocal slits extending posterolaterally from midlateral base of tongue; vocal sac single, median, subgular; unpigmented nuptial pads present.

Dorsum of head, body, and limbs smooth with scattered low tubercles on posterior part of body, small, subconical tubercles; dorsolateral folds absent; flanks finely tuberculate; cloacal sheath short; skin on throat weakly areolate, on belly coarsely areolate; discoidal fold barely evident posteriorly. Ulnar tubercles absent; thenar tubercle ovoid, about $\frac{1}{2}$ size of bifid palmar tubercle; supernumerary palmar tubercles few, minute; subarticular tubercles prominent, round; fingers bearing distinct lateral fringes; Finger I shorter than II; disc on thumb barely expanded; disk on Finger II slightly larger; discs on Fingers III-IV broadly rounded, more than twice width of digits; all fingers having ventral pads defined by circumferential grooves. Upper surfaces of hind limbs smooth; heel and outer edge of tarsus lacking tubercles; inner edge of tarsus bearing low, elongate tubercle; inner metatarsal tubercle elevated, elliptical, about 10 \times low, round, outer metatarsal tubercle; supernumerary plantar tubercles numerous; subarticular tubercles round, subconical; toes bearing narrow lateral fringes; webbing absent; discs on toes equal in size to those on fingers; tip of Toe V extending to distal edge of distal subarticular tubercle on Toe IV; tip of Toe III extending to distal edge of penultimate subarticular tubercle on Toe IV; when hind limbs flexed perpendicular to axis of body, heels barely overlapping; shank 51.8-52.5 (\bar{x} = 51.2), 50.0% SVL.

Coloration in preservative: Dorsum tan with dark brown markings—KU 212264; elongate mark on snout, interorbital bar, canthal stripe. Supratympanic stripe, labial bars, W-shaped mark in scapular region (absent in KU 212229); chevron in sacral region (absent in KU 212229 and 212310). Diagonal bars on flanks and limbs, digits cream with dark brown transverse bars, discs cream with dark brown on distal edges. Posterior surfaces of thighs brown with cream mottling in KU 212229-300 and cream flecks in KU 212310. Venter creamy tan with fine dark brown reticulations (brown flecks in KU 212301).

Coloration in life: KU 212301, female: Dorsum reddish brown with dark brown marking; venter and anterior and posterior surfaces of thighs gray; iris dull bronze with median, horizontal, red streak (Fig. 9). KU 212299, male:

Dorsum tan, black dorsolaterally with greenish-tan bars on flanks; dorsal surfaces of limbs olive-brown with yellowish-tan bars; axilla, groin, and ventral surfaces of hind limbs salmon; throat and belly dull yellow with black flecks; salmon suffusion on belly; iris reddish copper. KU 212300, male: Dorsum mottled reddish brown and dark brown; flanks cream with diagonal cream bars; venter cream with gray mottling; iris bronze with median, horizontal, red streak.

Measurements of holotype: SVL 27.4, tibia length 13.7, foot length 11.6, head width 10.4, head length 10.7, IOD 2.4, upper eyelid width 1.7, E-N 3.0, eye 3.0, tympanum 1.2.

Distribution and habitat.—The species is known from three localities at 680-1200 m on the east slope of the northern part of the Cordillera Central in northern Peru, where they were found in lower humid montane forest (Fig. 22). The juvenile was on the ground by day, and one male was in the axil of an elephant ear plant (*Xanthosoma*) by day. The female was on the leaf of an elephant ear plant at night, and a male was on the leaf of an herb at night.

Etymology.—The specific name is derived from the Greek *ardalos* meaning dirty and the Greek *onychos* meaning fingernail; the name is applied in reference to the irregular, dark periphery of the discs on the fingers.

Remarks.—One juvenile male (KU 212310) has a SVL of 14.4 mm. In life, the dorsum was black with a tan mid-dorsal stripe broken by a black interorbital bar and at the level of the forelimbs. The flanks and dorsal surfaces of the thighs were marked with yellow bars; the throat and chest were black with pale yellow flecks, and the belly and groin were cream with yellow flecks. The iris was bronze-brown.

Eleutherodactylus barsei Duellman

Eleutherodactylus barsei Duellman, 1992a:2. Holotype: KU 212268, adult female, from Cataratas Ahuashiyacu, 730 m, 14 km [by road] NE Tarapoto, Provincia San Martín, Departamento San Martín, Peru.

Diagnosis.—A member of the *Eleutherodactylus* (*Eleutherodactylus*) *unistrigatus* Group having (1) skin on dorsum shagreen, bearing scattered low tubercles in males, that on venter areolate; discoidal fold evident only posteriorly; dorsolateral folds absent; (2) tympanic membrane and tympanic annulus prominent, vertically ovoid, its length about 30% length of eye; (3) snout acutely rounded in dorsal view, bluntly rounded in profile; canthus rostralis angular; (4) upper eyelid lacking small tubercles, broader than IOD; cranial crests absent; (5) vomerine odontophores transverse, prominent; (6) males having vocal slits but lacking nuptial pads; (7) Finger I shorter than II; discs broad; (8) fingers bearing lateral fringes; (9) ulnar tubercles diffuse; (10) heel lacking tubercles; outer edge of tarsus bearing tubercles; inner edge of lacking tubercles or fold; (11) inner metatarsal tubercle oval, 8-10 \times subconical outer

metatarsal tubercle; supernumerary tubercles diffuse, present only proximally; (12) toes bearing lateral fringes; webbing absent; Toe V much longer than III; discs nearly as large as those on fingers; (13) dorsum brown with darker brown marks on back and transverse bars on limbs; venter brown with cream flecks; (14) SVL in males 22.7–25.5 mm, in females 38.0–38.8 mm.

Only three species of *Eleutherodactylus* in the Andes of northern Peru have pale spots or flecks on brown flanks. In *Eleutherodactylus bearsei*, cream flecks are present on the flanks; the posterior surfaces of the thighs are uniform brown. The flanks have cream (*E. rufioculis*) or white (*E. muscosus*) spots, and the posterior surfaces of the thighs have cream spots in *E. muscosus*. The latter and *E. rufioculis* have smooth skin on the dorsum (shagreen and tuberculate in *E. bearsei*); the former also differs from *E. bearsei* by having a conical tubercle on the heel, and the latter differs by lacking a tympanic membrane.

Description.—The description by Duellman (1992a) is adequate.

Distribution and habitat.—This species is known from the type locality and 30 km [by road] SW Zapatero (ca. 10 km NE San José de Sisa), 500 m, Provincia Lamas, Departamento San Martín, Peru (Fig. 22). Adults were found on mossy boulders and juveniles on herbaceous vegetation at night in deep ravine at elevations of 500 and 730 m in lower humid montane forest.

Remarks.—As noted by Duellman (1992a), *Eleutherodactylus bearsei* can be grouped phenotypically with three other species (*E. diadematus*, *eurydactylus*, and *platydactylus*) in the upper Amazon Basin and on the lower Amazonian slopes of the Andes.

Eleutherodactylus bromeliaceus Lynch

Eleutherodactylus bromeliaceus Lynch, 1979:12. Holotype: USNM 199731, adult female, from between Sapote and Suro Rancho, Provincia Morona-Santiago, Ecuador.

Diagnosis.—A member of the *Eleutherodactylus* (*Eleutherodactylus*) *unistrigatus* Group having (1) skin on dorsum smooth, that on venter coarsely areolate; discoidal fold prominent; dorsolateral folds absent; (2) tympanic membrane and tympanic annulus evident, round, its length about 30% length of eye; (3) snout subacuminate in dorsal view, acutely rounded in profile; canthus rostralis rounded; (4) upper eyelid bearing small tubercles, slightly narrower than IOD; cranial crests absent; (5) vomerine odontophores oblique, prominent; (6) males having vocal slits but lacking nuptial pads; (7) Finger I shorter than II; discs elliptical; (8) fingers bearing lateral fringes; (9) ulnar tubercles absent; (10) heel and outer edge of tarsus bearing low tubercles; inner edge of tarsus bearing one tubercle; (11) inner metatarsal tubercle oval, 3× elongate outer metatarsal tubercle; supernumerary tubercles numerous; (12)

toes bearing lateral fringes; webbing absent; Toe V much longer than III; discs slightly smaller than those on fingers; (13) dorsum tan with brown flecks or blotches on dorsum; venter cream, with brown flecks in adult females; (14) SVL in males 16.7–23.2 mm, in females 22.9–28.1 mm.

This species with a broad head and pointed snout has small tubercles on the upper eyelid and on the heel. Other species with this combination of characters are *Eleutherodactylus ceuthospilus*, *rhodoplichus*, and *schultei*. *Eleutherodactylus ceuthospilus* differs by having the skin on the dorsum shagreen and having a brown (as opposed to green) dorsum in life and pale spots in the groin; *E. rhodoplichus* differs by lacking vomerine odontophores and labial bars and by having dark diagonal bars or reticulations on the flanks and dark reticulations on the posterior surfaces of the thighs, whereas *E. schultei* differs by having a uniformly pale dorsum (as opposed to dark spots) and dark streaks on the flanks, and by lacking labial bars, pale spots on the posterior surfaces of the thighs, and dark flecks on the venter.

Description.—The description by Lynch (1979) is adequate.

Distribution and habitat.—The distribution of this species is discontinuous. It is known from the Amazonian slopes of the Cordillera Oriental (1707–2622 m), northern (1500–1600 m) and western (1830 m) slopes of the Cordillera del Cóndor, and the Cordillera de Cutucú (1700 m) in southern Ecuador, and from Abra Pardo de Miguel (2180 m) in the northern part of the Cordillera Central, Departamento San Martín, Peru (Fig. 22). All localities are in humid montane forests, where individuals were found on low vegetation at night and in bromeliads by day. At Abra Pardo de Miguel, a female was on the leaf of a herb and a male was calling from the leaf of a bush on the night of 31 January 1989; the call is a soft “peep.”

Remarks.—Previously, this species has been recorded only from Ecuador (Almendáriz, 1997; Duellman and Lynch, 1988; Lynch, 1980). The two Peruvian specimens (KU 212213–14) are a subadult female having a SVL of 22.7 mm and an adult male having a SVL of 23.0 mm, respectively. In life, the dorsum of the female was mottled green and brown, and the venter was gray; the dorsum of the male was tan with brown mottling, and the flanks, groin and vocal sac were yellow and the belly cream. In both individuals, the iris was red to reddish brown.

Eleutherodactylus cajamarcensis Barbour and Noble

Eleutherodactylus cajamarcensis Barbour and Noble, 1920:404. Holotype: MCZ 5407, adult male, from ruins near Huambos, Departamento Cajamarca, Peru.

Diagnosis.—A member of the *Eleutherodactylus* (*Eleutherodactylus*) *unistrigatus* group having (1) skin on dorsum shagreen, bearing ill-defined rows of pustules, that

on venter areolate; discoidal fold prominent; dorsolateral folds absent; (2) tympanic membrane and tympanic annulus prominent, round, its length no more than $\frac{1}{2}$ length of eye; (3) snout rounded in dorsal view and in profile; canthus rostralis angular; (4) upper eyelid bearing small tubercles, slightly narrower than IOD; cranial crests absent; (5) vomerine odontophores oblique, not prominent; (6) males having vocal slits and nuptial pads; (7) Finger I shorter than II; discs small, round; (8) fingers lacking lateral fringes; (9) ulnar tubercles indistinct or absent; (10) heel and outer edge of tarsus lacking tubercles; inner edge of tarsus usually bearing one tubercle; (11) inner metatarsal tubercle oval, 4–6 \times outer metatarsal tubercle; plantar supernumerary tubercles numerous; (12) toes bearing lateral fringes; webbing absent; Toe V much longer than Toe III; discs as large as those on fingers; (13) dorsum gray to pale brown with darker brown markings; venter cream with brown or gray spots; (14) SVL in males 19.2–24.1 mm, in females 27.1–33.8 mm.

The only other members of the *Eleutherodactylus unistrigatus* Group in the Andes of northern Peru that have pale spots in the groin are *E. ceuthospilus*, *lirellus*, *muscosus*, and *rufiocularis*. In all of these, the pale spots are not set in a black field, as in *E. cajamarcensis*. Furthermore, the larger *E. muscosus* has a conical tubercle on the heel and white (instead of brown) spots on the flanks, whereas the smaller *E. rufiocularis* lacks a tympanic membrane and tubercles on the upper eyelid, and has cream (instead of brown) spots on the flanks. The much smaller *E. lirellus* lacks a tympanic membrane and annulus. *Eleutherodactylus ceuthospilus* differs by lacking brown spots on the flanks and having dark flecks (instead of spots) on the venter; the spots in the groin are bright yellow in life. In *E. cajamarcensis*, the large spots in the groin are red in life.

Description.—Lynch (1969) provided a thorough redescription of the species. Coloration of living individuals from Peru was described by Duellman and Wild (1993) and of individuals from southern Ecuador by Lynch and Duellman (1997).

Distribution and habitat.—This species is widely distributed in the mountains of the Huancabamba Depression and around the Cuenca de Loja, where it occurs at elevations of 1800–3100 in tropical dry forest, humid montane forest, and subparamo (Fig. 22). A few records exist for the Pacific slopes of the Cordillera Occidental in Peru (Huambos, Departamento Cajamarca) and in Ecuador (Luz María, Provincia Azuay). Most individuals have been found under rocks and logs or in arboreal or terrestrial bromeliads by day; few have been observed perched on low vegetation at night.

Remarks.—*Eleutherodactylus cajamarcensis* is the most widespread species of the genus in western Peru and adjacent Ecuador.

Eleutherodactylus ceuthospilus Duellman and Wild

Eleutherodactylus ceuthospilus Duellman and Wild, 1993:8. Holotype: KU 219775, adult male, from 15.8 km [by road] ENE Canchaque, 1800 m, Departamento Piura, Peru.

Diagnosis.—A member of the *Eleutherodactylus (Eleutherodactylus) unistrigatus* Group having (1) skin on dorsum shagreen with minute, low, round tubercles and lacking folds, that on venter areolate; discoidal fold evident; dorsolateral folds absent; (2) tympanic membrane and tympanic annulus prominent, round, its length about $\frac{1}{2}$ length of eye; (3) snout acutely rounded in dorsal view and in profile; canthus rostralis rounded; (4) upper eyelid bearing small tubercles, narrower than IOD; cranial crests absent; (5) vomerine odontophores low, round, concealed in buccal mucosa; (6) males having vocal slits but lacking nuptial pads; (7) Finger I shorter than II; discs large, elliptical; (8) fingers bearing lateral fringes; (9) ulnar tubercles low, diffuse; (10) heel lacking tubercles; outer edge of tarsus with few, low, round tubercles; inner edge of tarsus bearing low tubercles or fold; (11) inner metatarsal tubercle oval, 6 \times subconical outer metatarsal tubercle; plantar supernumerary tubercles numerous; (12) toes bearing lateral fringes; webbing absent; Toe V much longer than III; discs nearly as large as those on fingers; (13) dorsum gray to pale brown, usually with small brown flecks or streaks; venter cream with minute dark flecks; (14) SVL in males 19.0–25.8 mm, in females 23.5–26.7 mm.

Eleutherodactylus ceuthospilus most closely resembles *E. cajamarcensis*, which differs by having dark (instead of pale) spots on the flanks and dark spots (instead of flecks) on the venter; moreover, the spots in the groin are dull red in life in *E. cajamarcensis* and bright yellow in *E. ceuthospilus* (Fig. 9). Other members of the *Eleutherodactylus unistrigatus* group in the region that have pale spots in the groin are the larger *E. muscosus* and the smaller *E. lirellus* and *E. rufiocularis*; both of the small species lack a tympanic membrane (annulus also absent in *E. lirellus*), whereas *E. muscosus* differs in color pattern (white reticulations on the dorsum) and by having a conical tubercle on the heel.

Description.—The description given by Duellman and Wild (1993) is adequate.

Distribution and habitat.—This species is known from humid montane forest at elevations of 1735–2870 m on the western slopes of the Cordillera de Huancabamba, and from a site at 12 km [by road] W of Lamas (1500 m) on the Pacific slope of the Cordillera Occidental in northern Peru (Fig. 23). Males call from low vegetation in cloud forest at night; adults of both sexes have been found in bromeliads by day.

Remarks.—Richard Thomas (field notes, 8 December 1974) described the call as ratchetlike, rapid sequence of three (rarely 2 or 4) clicks repeated at intervals of 15–20 sec.

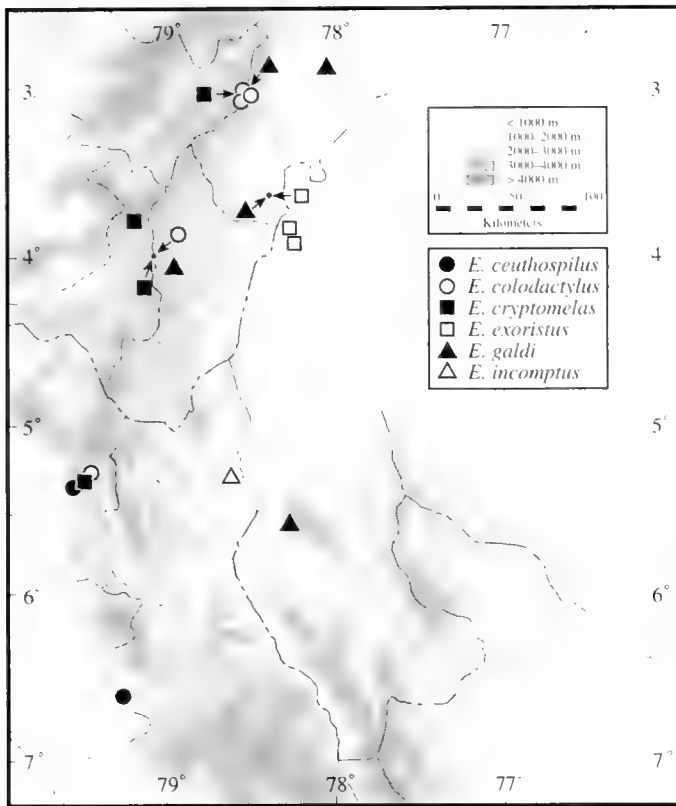

Fig. 23. Localities of known occurrence of six species in the *Eleutherodactylus unistrigatus* group in the Andes of southern Ecuador and northern Peru.

Eleutherodactylus colodactylus Lynch

Eleutherodactylus colodactylus Lynch, 1979:15. Holotype: KU 142151, adult female, from Abra de Zamora, 2800 m, 13.5 km [by road] E Loja, Provincia Loja, Ecuador.

Diagnosis.—A member of the *Eleutherodactylus* (*Eleutherodactylus*) *unistrigatus* Group having (1) skin on dorsum and venter areolate; discoidal fold and dorsolateral folds absent; (2) tympanic membrane and tympanic annulus absent; (3) snout rounded in dorsal view, bluntly rounded in profile; canthus rostralis rounded; (4) upper eyelid bearing one or two small but prominent tubercles, narrower than IOD; cranial crests absent; (5) vomerine odontophores oval, concealed; (6) males lacking vocal slits and nuptial pads; (7) Finger I shorter than II; discs small, round; (8) fingers having lateral fringes; (9) ulnar tubercles absent; (10) heel bearing single, conical tubercle; tarsus lacking tubercles and fold; (11) inner metatarsal tubercle oval, 4–5× round outer metatarsal tubercle; plantar supernumerary tubercles numerous, continuing onto toes; (12) toes bearing lateral fringes; webbing basal; Toe V longer than III; discs about as large as those on fingers; (13) dorsum brown with pale dorsolateral stripes or interorbital bar; venter cream with brown flecks; (14) SVL in males 14.0–20.7 mm, in females 16.5–25.8 mm.

In the region under consideration, only *Eleutherodactylus proserpens* is like *E. colodactylus* in having short, stocky fingers, but *E. colodactylus* differs from *E. proserpens* by lacking a cloacal sheath, tympanic membrane and annulus, a papilla on the tip of the snout, and prominent vomerine odontophores. In other *Eleutherodactylus* in the region having digital pads that are only slightly broader than the digit proximal to the pad (*E. atrabracus*, *melanogaster*, *pataikos*, and *pinguis*), the fingers are proportionately longer and more slender than those in *E. colodactylus* and *E. proserpens*; moreover, in those robust-bodied species, Toe V is only slightly longer than Toe III. The absence of a tympanum and tympanic annulus distinguishes *E. colodactylus* from all other species in the region, except *E. lirellus*; the latter differs by having vocal slits, labial and limbs bars, a yellow spot in the groin, black flecks on the venter, and long fingers bearing elliptical discs.

Description.—The original description by Lynch (1979) was augmented with data from Peruvian specimens by Duellman and Wild (1993).

Distribution and habitat.—This species is known from two disjunct regions—Amazonian slopes (2195–3140 m) of the Cordillera Oriental in Provincia Morona-Santiago, Ecuador; the crest and Amazonian slopes (2710–2800 m) of the Abra de Zamora in the southern Cordillera Oriental; and the crest and upper eastern slopes of the Cordillera de Huancabamba in northern Peru (Fig. 23). All individuals for which habitat data are available were found in terrestrial and arboreal bromeliads by day in humid montane forest or subparamo.

Eleutherodactylus cryptomelas Lynch

Eleutherodactylus cryptomelas Lynch, 1979:21. Holotype: KU141992, immature female, from 15 km [by road] E of Loja, 2710 m, Provincia Morona-Santiago, Ecuador.

Diagnosis.—A member of the *Eleutherodactylus* (*Eleutherodactylus*) *unistrigatus* Group having (1) skin on dorsum shagreen, bearing conical warts and ridges, that on venter areolate; discoidal fold prominent; dorsolateral folds absent; (2) tympanic membrane and tympanic annulus prominent, its length 30–40% length of eye; (3) snout subacuminate in dorsal view, rounded in profile; canthus rostralis rounded; (4) upper eyelid bearing tubercles, slightly broader than IOD; cranial crests absent; (5) vomerine odontophores round to oval, prominent; (6) males lacking vocal slits and nuptial pads; (7) Finger I shorter than II; discs broad, elliptical; (8) fingers having weak lateral fringes; (9) ulnar tubercles prominent; (10) heel and outer edge of tarsus bearing conical tubercles; inner edge of tarsus bearing indistinct tubercle; (11) inner metatarsal tubercle oval, 4–6× conical outer metatarsal tubercle; plantar supernumerary tubercles numerous; (12) toes bearing lateral fringes; webbing absent; Toe V longer than III; discs

smaller than those on fingers; (13) dorsum gray to brown sparse darker markings; venter white to cream with brown reticulations; (14) SVL in males 28.2–30.2 mm, in female 38.6 mm.

Eleutherodactylus cryptomelas is readily distinguished from all other members of the *Eleutherodactylus unistrigatus* Group in the region by having the groin and hidden surfaces of the thighs uniform black. The only other species having extensive black coloration are short-legged members of the *Eleutherodactylus orestes* group—*E. atrabracus* with black on the undersides of the hind limbs and *E. melanogaster*, which is nearly uniform black dorsally and ventrally; both species have pale yellow spots in the groin.

Description.—The original description by Lynch (1979) is adequate, but coloration in life was expanded by Duellman and Wild (1993).

Distribution and habitat.—This species is known from elevations of 2470–2710 m on the Amazonian slopes of the Cordillera Oriental and the ridges (3000–3100 m) north of the Cuenca de Loja in Ecuador, and at elevations of 2770–2820 m on the western slope of Cordillera de Huancabamba in Peru (Fig. 23). In Ecuador, the frogs were found in terrestrial bromeliads or under rocks in paramo and subparamo by day. In Peru, the frogs were in humid montane forest; one was under a rock by day, and another was in a tree at night

Eleutherodactylus exoristus new species

Holotype.—KU 147051, an adult female, from the Río Piuntza (03°52' S, 78°15' W, 1550 m), western slope of the Cordillera del Cóndor, Provincia Morona-Santiago, Ecuador, one of a series collected on 3 January 1972 by John E. Simmons, Robert Fiske, and Bruce MacBryde.

Paratypes.—KU 147048–49, 147053, 147056, adult males, and 147047, 147052, 147054–55, 147058, adult females, from the type locality, 3–6 January 1972.

Referred specimens.—KU 147050, 147057, juveniles, from the type locality; USNM 525442, an adult female, from Puesto Vigilancia Comainas, 665 m, Río Comainas, Departamento Amazonas, Peru; USNM 525448, 525462, 525470 from Alfonso Ugarte, 1138 m, upper Río Comainas, Departamento Amazonas, Peru.

Diagnosis.—A member of the *Eleutherodactylus (unistrigatus) unistrigatus* Group having (1) skin on dorsum tuberculate with small conical tubercles in dorsolateral rows, that on venter areolate; discoidal fold evident; dorsolateral folds absent; (2) tympanic membrane differentiated; tympanic annulus prominent, round, its diameter slightly less than $\frac{1}{2}$ length of eye; (3) snout moderately long, acutely rounded in dorsal view, bluntly rounded in profile; (4) upper eyelid slightly narrower than IOD, bearing many conical tubercles; cranial crests absent; (5)

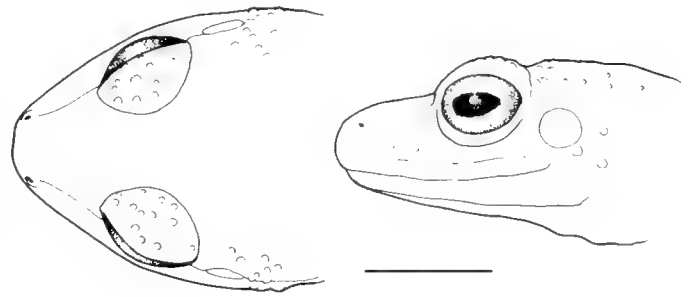

Fig. 24. Dorsal and lateral views of the head of *Eleutherodactylus exoristus*, KU 147051. Scale bar = 5 mm.

vomerine odontophores low, ovoid, oblique; (6) males having vocal slits but lacking nuptial pads; (7) Finger I shorter than II; discs on outer fingers elliptical, about twice width of digit proximal to pad; (8) fingers lacking lateral fringes; (9) ulnar tubercles absent; (10) heel and outer edge of tarsus lacking tubercles; inner edge of tarsus bearing low, elongate tubercle distally; (11) inner metatarsal tubercle elevated, elliptical, about 8× subconical outer metatarsal tubercle; supernumerary plantar tubercles few, low; (12) toes lacking lateral fringes; webbing absent; Toe V much longer than III; discs nearly as large as those on outer fingers; (13) dorsum brown with darker brown markings; flanks pale tan, usually with diffuse diagonal bark bars; venter tan with dark brown flecks; posterior surfaces of thighs brown with small cream flecks ventrally; (14) SVL in four adult males 15.0–16.9 (\bar{x} = 16.2) mm and six adult females 21.3–23.5 (\bar{x} = 22.7) mm.

Eleutherodactylus exoristus differs from all other species in the region by having flared lips and tubercles arranged in sinusoidal dorsolateral rows on the body. This species is most similar to *E. percnopterus* and *E. serendipitus*, both of which lack lateral fringes on the digits and tubercles on the heels and have tubercles on the dorsum, but the tubercles are lower and not arranged in dorsolateral rows; furthermore, these species lack conical tubercles on the upper eyelids, are slightly larger, and vomerine odontophores are absent in *E. percnopterus*. Other species in the region having tubercles on the dorsum are *E. anemerus*, which lacks dorsal markings and has a tubercle on the tip of the snout, the much larger *E. bearsei*, which has a rounded snout, lateral fringes on the digits, and no tubercles on the upper eyelids, and *E. lanthanites*, which has a smooth venter, first finger longer than the second, and fifth toe only slightly longer than the third.

Description.—(n = 4 males, 6 females). Head slightly wider than body; HW 36.2–42.0 (\bar{x} = 38.7% SVL; HL 40.0–46.0 (\bar{x} = 42.8)% SVL; snout moderately long, acutely rounded in dorsal view, bluntly rounded in profile (Fig. 24); E–N 74.0–93.3 (\bar{x} = 83.9)% length of eye; nostrils slightly

protuberant, directed laterally; canthus rostralis distinctly angular, slightly curved; loreal region concave; lips flared; upper eyelid bearing many conical tubercles; upper eyelid width 81.5–91.3 (\bar{x} = 85.8)% IOD; cranial crests absent; supratympanic fold weak, barely obscuring upper edge of prominent tympanic annulus; side of head nearly vertical; tympanic membrane not pustular or thickened; tympanic annulus round, its diameter 37.9–52.3 (\bar{x} = 43.7)% length of eye; two or three conical postrictal tubercles posteroventral to tympanic annulus. Choanae small, oval, not concealed by palatal shelf of maxillary arch; vomerine odontophores, low, oblique, medial to posterior edges of choanae, oval in outline, narrowly separated medially, each bearing three teeth in males (odontophore absent on one side in each of two males), 3–6 (\bar{x} = 5.8) in females; tongue slightly more than twice as long as wide, its posterior border shallowly notched, posterior half not adherent to floor of mouth. Males with vocal slits extending posterolaterally from midlateral base of tongue; vocal sac single, median, subgular; nuptial pads absent.

Dorsum of head, body, and limbs bearing conical tubercles; in most individuals tubercles forming shallow, sinusoidal rows extending from posterior border of orbit to point posterior to sacrum; numerous low tubercles on dorsum of snout; dorsolateral folds absent; flanks finely tuberculate; skin on throat, belly, and ventral surfaces of thighs areolate; discoidal fold evident; cloacal sheath short; enlarged tubercles lateral to vent absent. Ulnar tubercles absent; thenar tubercle low, ovoid, nearly as large as low, bifid palmar tubercle; supernumerary palmar tubercles few, subconical; subarticular tubercles prominent, subconical; fingers lacking lateral fringes; Finger I shorter than II; disc on thumb moderately expanded; discs on other fingers elliptical, about twice width of digits proximal to pad; all fingers having ventral pads defined by circumferential grooves. Heel and outer edge of tarsus lacking tubercles; inner edge of tarsus bearing low, elongate tubercle distally; inner metatarsal tubercle elevated, elliptical, about 8× subconical outer metatarsal tubercle; supernumerary plantar tubercles few, low; subarticular tubercles low, round; toes lacking lateral fringes; webbing absent; discs on toes nearly as large as those on fingers; tip of Toe III extending to middle of distal subarticular tubercle on Toe IV; Toe V extending to point midway between penultimate and distal subarticular tubercles on Toe IV; when hind limbs flexed perpendicular to axis of body, heels overlapping by about 20% length of shank; shank 52.1–59.3 (\bar{x} = 54.3)% SVL.

Coloration in preservative: Dorsum of head, body, and limbs reddish brown with darker brown to black markings (Fig. 25) consisting of distinct labial bars and transverse bars on limbs and diffuse canthal stripe in all individuals, interorbital bar (8 individuals), narrow

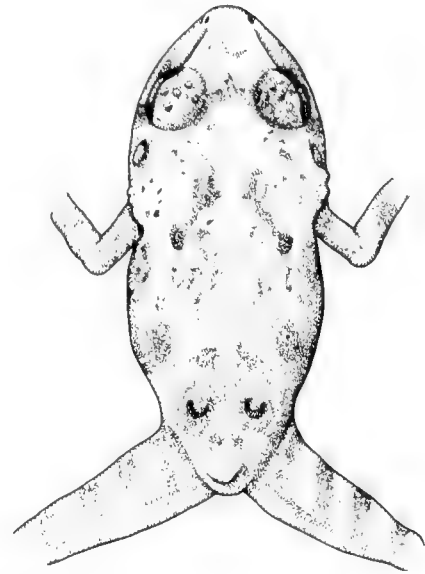

Fig. 25. Dorsal color pattern of *Elcutherodactylus exoristus*, KU 147051. SVL = 23.4 mm.

supratympanic stripe (5), W- or H-shaped mark in scapular region (4), paravertebral streaks on anterior part of body (6), diffuse sacral chevrons (3); one individual (KU 147050) with pale middorsal stripe, and one (KU 147058) with large cream blotch in sacral region. Flanks cream or tan with (8) or without (2) vertical to slightly diagonal bars; posterior surfaces of thighs brown with intrusion of tan dorsally and minute pale flecks ventrally; venter tan with brown flecks, most dense on throat and chest; two individuals with pale tan heels.

Coloration in life: Dorsum brown to reddish brown with darker brown markings; one with white middorsal stripe and one with yellow blotch in sacral region; flanks yellow with brown bars; venter gray with or without white flecks (John E. Simmons field notes, 3–6 January 1972).

Measurements of holotype: SVL 23.4, tibia length 12.5, foot length 10.5, head width 9.0, head length 9.6, IOD 2.3, upper eyelid width. 2.1, E–N 2.8, eye 3.0, tympanum 1.3.

Distribution and habitat.—This species is known from one locality at 1550 m on the western slopes of the northern part of the Cordillera del Cóndor and two localities along the Río Comainas (665 and 1138 m) on the eastern slopes of the southern part of the Cordillera del Cóndor (Fig. 23). All individuals were on low vegetation in humid montane forest at night.

Etymology.—The specific name is a Greek adjective, *exoristos*, meaning exiled. The name is applied in the sense of the species being restricted to the isolated Cordillera del Cóndor.

Remarks.—The two juveniles from the type locality have SVLs of 13.3 and 14.0 mm. They are colored like the adults; one has bars on the flanks, and in the other the flanks are uniform tan. Three subadult females from 1138 m on the eastern slopes of the Cordillera del Cónдор have SVLs of 17.4–19.4 (\bar{x} = 18.7) mm. Structurally, they are like the topotypes, except that USNM 525462 is less tuberculate on the dorsum. That individual has short paravertebral dark streaks and plain flanks; USNM 525470 has a diffuse middorsal blotch and plain flanks, whereas USNM 525448 has a dark chevron in the scapular region, a transverse bar in the sacral region, and barred flanks. In life, the last two individuals had “clear green” or “clear blue green” venters (Robert P. Reynolds field notes, 21 and 23 July 1994). The largest and most tuberculate specimen is an adult female (USNM 525442) having a SVL of 25.6 mm. It has a dark W-shaped mark in the scalar region, dark bars on the flanks, and faint brown reticulations on the posterior part of the belly. In life, the dorsum was brown with darker mottling, and the flanks were tan with brown bars; the venter was cream with brown spots, and the undersides of the thighs were reddish (Robert P. Reynolds field notes, 3 August 1994).

Eleutherodactylus galdi (Jiménez de la Espada)

Pristimantis galdi Jiménez de la Espada, 1870:62. Types, MNCN (now lost) from San José de Motí, Provincia Napo, Ecuador.

Hylodes festae Peracca, 1904:28. Holotype: MSNT AN413, ex. 3776, adult male, from San José de Cuchipamba, Provincia Morona-Santiago, Ecuador. Synonymy fide Lynch, 1974b:16.

Hylodes margaritifera Boulenger, 1912:189. Syntypes, BM 1912.11.1.54–55 (= 1947.2.16.78–79), from El Topo, Río Pastaza, Provincia Tungurahua, Ecuador. Synonymy fide Lynch, 1969:270.

Eleutherodactylus festae—Peters, 1955:348.

Eleutherodactylus margaritifera—Peters, 1955:349.

Eleutherodactylus galdi—Peters, 1955:350; Lynch, 1969:270; Lynch, 1974b:16.

Diagnosis.—A member of the *Eleutherodactylus* (*Eleutherodactylus*) *unistrigatus* Group having (1) skin on dorsum smooth to finely shagreen with scattered small tubercles, that on venter coarsely areolate, usually with scattered larger warts; discoidal fold evident; dorsolateral folds absent; (2) tympanic membrane differentiated, and tympanic annulus prominent, nearly round, its length $\frac{1}{4}$ – $\frac{1}{2}$ length of eye; (3) snout long, acuminate in dorsal view, truncate in profile, with slightly swollen tip; (4) upper eyelid bearing conical tubercle, narrower than IOD; cranial crests present, serrate in large females; (5) vomerine odontophores prominent, oblique; (6) males possessing vocal slits; nuptial pads absent; (7) Finger I shorter than II; discs on outer fingers expanded, truncate, more than twice width of digit proximal to pad; (8) fingers bearing weak lateral fringes; (9) ulnar tubercles conical; (10) heel, outer edge of tarsus, and outer edge of foot bearing conical tubercles; inner edge of tarsus lacking tubercles; (11) inner

metatarsal tubercle elliptical, 5–6 \times ovoid outer metatarsal tubercle; supernumerary plantar tubercles absent; (12) toes bearing weak lateral fringes; webbing absent; Toe V much longer than III; discs smaller than those on outer fingers; (13) dorsum cream (green in life) with dark brown canthal and supratympanic stripes, interorbital and limb bars, and sparse spotting on dorsum; venter cream with minute dark flecks and usually dark streaks on throat; posterior surfaces of thighs cream; (14) SVL in males 17.1–24.8 mm, in females 28.1–34.0 mm (Lynch and Duellman, 1980).

The green (in life) or cream (in preservative) coloration in combination with an acuminate snout, flared lips, greatly expanded, truncate discs on the outer fingers, row of conical tubercles extending from the heel to the outer edge of the foot, and serrate cranial crests (in large females) immediately distinguish *Eleutherodactylus galdi* from all other species in the region. The only other predominately green species is *E. acuminatus*, which has rounded lips and elliptical discs and lacks tubercles along the tarsus, cranial crests, and bars on the limbs; moreover, *E. acuminatus* has an undifferentiated tympanic membrane. *Eleutherodactylus quaquaversus* also has a conical tubercle on the upper eyelid and a conical tubercle on the heel, but it lacks a tympanum, cranial crests, tubercles along the outer edge of the tarsus and foot, and large, truncate discs on the fingers.

Description.—Adequate descriptions and illustrations were provided by Lynch (1969) and Lynch and Duellman (1980).

Distribution and habitat.—In Ecuador, this gaudy arboreal species is known in humid montane forests at elevations of 1000–1740 m on the eastern face of the Cordillera Oriental (Lynch and Duellman, 1980), 1700–1975 m in the Cordillera de Cutucú (Duellman and Lynch (1988), and 1500–1550 in the Cordillera del Cónдор (Almendáriz, 1997; Lynch and Duellman, 1980). The only Peruvian record is from 12 km [by trail] east of La Peca, 1700 m on the western slope of the Cordillera Colán, Provincia Bagua, Departamento Amazonas (Fig. 23). The specimen was along a stream in humid montane forest.

Remarks.—The single Peruvian specimen (LSUMZ 39362) is a juvenile having a SVL of 13.9 mm. In this small specimen, cranial crests and ventral warts are not evident. The dorsum is yellowish tan with dark brown canthal and supratympanic stripes, narrow interorbital bar, pair of diagonal (directed posteromedially) streaks in the scapular region, chevron in sacral region, and limb bars. Several short, dark brown streaks are present on the posterior part of the throat.

Eleutherodactylus incomptus Lynch and Duellman

Eleutherodactylus incomptus Lynch and Duellman, 1980:35. Holotype: KU 143484, adult male, from 16.5 km [by road] NNE Santa Rosa, 1700 m, Provincia Napo, Ecuador.

Diagnosis.—A member of the *Eleutherodactylus* (*Eleutherodactylus*) *unistrigatus* Group having (1) skin on dorsum smooth with low, flat tubercles, that on venter coarsely areolate; discoidal fold prominent; dorsolateral folds absent; (2) tympanic membrane smooth, and tympanic annulus prominent, nearly round, its length about 30% length of eye; (3) snout moderately short, rounded in dorsal view and in profile; (4) upper eyelid with or without tubercles, as wide as IOD; cranial crests absent; (5) vomerine odontophores not visible except in large females, low, oblique; (6) males possessing vocal slits and nonspinous nuptial pads; (7) Finger I shorter than II; discs on outer fingers expanded, rounded, about twice width of digit proximal to pad; (8) fingers bearing narrow lateral fringes; (9) ulnar tubercles absent; (10) heel and outer edge of tarsus lacking tubercles; inner edge of tarsus bearing one or two tubercles; (11) inner metatarsal tubercle oval, 5–6× subconical outer metatarsal tubercle; supernumerary plantar tubercles numerous; (12) toes bearing narrow lateral fringes; webbing absent; Toe V much longer than III; discs equal in size to those on outer fingers; (13) dorsum brown with darker brown markings—interorbital bar, W-shaped or diagonal shaped marks in scapular region, and labial and limb bars; venter brown; posterior surfaces of thighs dark brown; (14) SVL in males 15.6–18.8 mm, in females 23.7–25.9 mm (Lynch and Duellman, 1980).

Eleutherodactylus incomptus is most easily confused with *E. percnopterus*, which is similar in size and also lacks vomerine odontophores; the latter differs from *E. incomptus* by having the snout subacuminate in dorsal view, discs on fingers nearly truncate, digits lacking lateral fringes, inner edge of tarsus lacking tubercles, and males lacking nuptial pads. Furthermore, in *E. percnopterus*, the only distinct dorsal markings consist of a pair of small black spots or streaks in the scapular region, and the venter is cream. The only other member of the *Eleutherodactylus unistrigatus* Group in the Andes of northern Peru that lacks vomerine odontophores is *E. anemerus*, a frog that lacks dorsal markings and has an orange-red dorsum, yellow flanks, and a prominent tubercles on the snout. Three other species (*E. atrabracus*, *melanogaster*, and *pataikos*) are robust-bodied members of the *E. orestes* Group that have small terminal discs on the fingers, short hind limbs, and Toe V only slightly longer than Toe III. In its absence of distinctive features, *Eleutherodactylus incomptus* is like *E. pecki*, which differs from the former by having vomerine odontophores, a small tubercle on the heel and distinctly larger digital discs. It also resembles *E. exoristus*, which differs by having finely tuberculate skin on the dorsum, tubercles on the upper eyelid, cream flecks on the posterior surfaces of the thighs, and dark flecks on a cream venter.

Distribution and habitat.—*Eleutherodactylus incomptus* has been reported from elevations of 1370–1910 m on the

Amazonian slopes of the Cordillera Oriental in Ecuador (Lynch and Duellman, 1980). The present specimens (KU 217319–20) represent the first records of the species from Peru; they were in terrestrial bromeliads (*Aechmea*) by day at Santa Rosa de la Yunga, 19 km north of Pongo de Rentema on the Río Marañón, Provincia San Ignacio, Departamento Cajamarca, by W. Razzetto and W. A. Alarcón on 15 July 1989. This locality is at about 1300 m on the southern slopes of the Cordillera del Cóndor (Fig. 23).

Remarks.—The two specimens are a subadult female having a SVL of 18.2 mm and a juvenile having a SVL of 13.9 mm. Both specimens have the dark brown W-shaped mark in the scapular region.

Eleutherodactylus infraguttatus sp. nov.

Holotype.—KU 212297, adult female, from the east slope of Abra Pardo de Miguel (05°46' S, 77°42' W, 2180 m), Provincia Rioja, Departamento San Martín, Peru, one of a series of five specimens collected on 31 January 1989 by William E. Duellman.

Paratypes.—KU 212298, 212314–16 from the type locality, and KU 217317 from 14 km [by road] west of Venceremos, 2000 m, Provincia Rioja, Departamento San Martín, Peru.

Diagnosis.—A member of the *Eleutherodactylus* (*Eleutherodactylus*) *unistrigatus* Group having (1) skin on dorsum smooth with scattered, small tubercles, that on venter areolate; discoidal fold absent; dorsolateral folds absent; (2) tympanic membrane evident, and tympanic annulus thin, not prominent, higher than long, its length $\frac{1}{4}$ – $\frac{1}{2}$ length of eye; (3) snout short, rounded in dorsal view and in profile; (4) upper eyelid with small tubercles posteriorly, about as wide as IOD; cranial crests absent; vomerine odontophores low, oval in outline; (6) males possessing vocal slits but lacking nuptial pads; (7) Finger I shorter than II; discs on outer fingers nearly truncate, more than twice width of digit proximal to pad; (8) fingers bearing narrow lateral fringes; (9) ulnar tubercles prominent; (10) heel and inner edge of tarsus lacking tubercles; (11) inner metatarsal tubercle ovoid, about 5× round outer metatarsal tubercle; supernumerary plantar tubercles evident; (12) toes bearing narrow lateral fringes; webbing absent; Toe V slightly longer than III; discs equal in size to those on outer fingers; (13) dorsum brown with diffuse darker markings; venter cream with dark brown mottling; throat brown with cream mottling; groin and posterior surfaces of thighs cream to tan with brown bars; (14) SVL in one male 15.8 mm, in three females 22.9–24.3 mm (\bar{x} = 23.6).

Eleutherodactylus infraguttatus has more distinct dark mottling on the belly than any other member of the *Eleutherodactylus unistrigatus* Group in the region. Four other species have dark reticulations on the belly, but all have dark labial bars (absent in *E. infraguttatus*). Further-

more, of these species, *E. ardalonychus* differs by lacking tubercles of the upper eyelid and diagonal bars on the flanks, and *E. muscosus* differs by having a conical tubercle on the heel and pale spots on the flanks; *E. versicolor* lacks vocal slits and has distinct bars on the flanks, whereas in *E. cryptomelas*, the groin and hidden surfaces of the thighs are black.

Description.—($n = 4$; 1 male, 3 females; proportions are for male, followed by range and mean in parentheses of three females). Head as wide as body in male and in mature females, wider than body in gravid females; HW 39.2, 37.4–38.9% ($\bar{x} = 38.1$) SVL; HL 37.9, 37.1–40.1% ($\bar{x} = 38.8$) SVL; snout short, rounded in dorsal view, and in profile; E–N 68.3, 60.0–74.6% ($\bar{x} = 68.9$)% length of eye; nostrils slightly protuberant, directed laterally; canthus rostralis weakly angular, barely concave; loreal region weakly concave sloping abruptly to lips; lips not flared; upper eyelid with small tubercles posteriorly; upper eyelid width 63.6, 70.3–89.0% ($\bar{x} = 76.9$)% IOD; cranial crests absent; supratympanic fold weak, barely obscuring upper edge of tympanic annulus; side of head nearly vertical; tympanic annulus thin; tympanic membrane not pustular or thickened; tympanic annulus slightly higher than long; length of tympanic annulus 42.1, 26.9–33.3% ($\bar{x} = 30.7$)% length of eye; postrictal tubercles small, subconical, posteroventral to tympanic annulus; skin on head smooth. Choanae small, round, not concealed by palatal shelf of maxillary arch; vomerine odontophores posteromedian to choanae (absent in one female), oval in outline, each about twice size of choana, separated medially by distance less than width of odontophore, each bearing two teeth in male and 4–6 teeth in female in single row; tongue longer than wide, its posterior border deeply notched, posterior half not adherent to floor of mouth; vocal slits short, posterolateral to base of tongue; vocal sac single, median, subgular.

Dorsum smooth with scattered, small, subconical tubercles and faint dermal ridge from posteromedian border of eyelid to scapular region (most evident in male); dorsolateral folds; flanks smooth; cloacal sheath and enlarged tubercles in cloacal region absent; skin on throat and belly areolate; discoidal fold absent. Upper surfaces of arms smooth; ulnar tubercles round; thenar tubercle ovoid, smaller than bifid palmar tubercle; supernumerary palmar tubercles prominent, round, smaller than round, non conical subarticular tubercles; fingers bearing narrow lateral fringes; Finger I shorter than II; disc on thumb not expanded; discs on Fingers II–IV nearly truncate, twice width of digits; all fingers having ventral pads defined by circumferential grooves; nuptial pads absent in male. Upper surfaces of hind limbs smooth with scattered subconical tubercles; heel tubercles absent; outer edge of tarsus lacking tubercles; inner metatarsal tubercle nearly round, flat, about 5× subconical outer metatarsal tubercle;

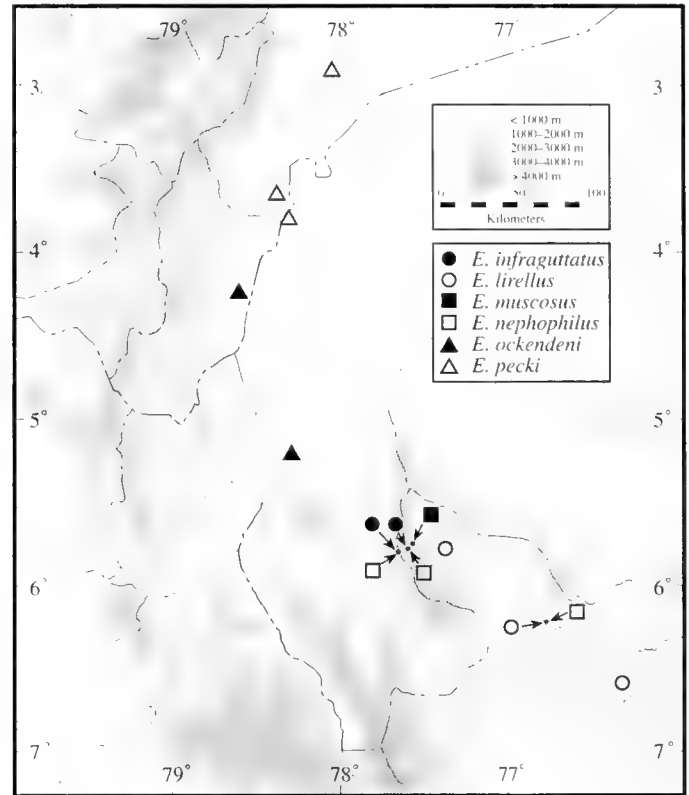

Fig. 26. Localities of known occurrence of six species in the *Eleutherodactylus unistrigatus* group in southern Ecuador and northern Peru.

supernumerary plantar tubercles small, subconical; subarticular tubercles round, not conical; toes bearing lateral fringes; webbing absent; discs on toes nearly as large as those on fingers; tip of Toe V extending to distal edge of distal subarticular tubercle on Toe IV; tip of Toe III not extending to that tubercle; when hind limbs flexed perpendicular to axis of body, heels barely overlapping; shank 49.4%, 46.7–50.8 ($\bar{x} = 49.0$)% SVL.

Coloration in preservative: Dorsum brown with darker brown canthal stripe, supratympanic stripe, interorbital bar, scapular marks, and transverse bars on limbs; flanks creamy tan with brown suffusion or spots posteriorly; anterior and posterior surfaces of thighs brown, mottled with cream; venter cream with brown marbling in females, primarily brown in male.

Coloration in life: Dorsum mottled dull olive and tan; flanks yellow and brown (Fig. 9); anterior surfaces of thighs red; venter greenish yellow with brown mottling; iris dull bronze with median, horizontal, brown streak (WED field notes on holotype, 31 January 1988).

Measurements of holotype: SVL 22.9, tibia length 10.7, foot length 9.9, head width 8.9, head length 8.5, IOD 2.8, upper eyelid width 2.0, E–N 1.8, eye 2.5, tympanum 0.8.

Distribution and habitat.—The species is known only from two localities at 2000 and 2180 m along the road from Abra Pardo de Miguel to Moyobamba on the east slope of the northern part of the Cordillera Central in northern Peru (Fig. 26). All individuals were on leaves on low vegetation (< 1 m) above the ground in humid montane forest at night.

Etymology.—The specific name is derived from the Latin prefix *infra*—meaning underside and the Latin adjective *guttatus* meaning dappled; the name is applied in reference to the dark mottling on the venter.

Remarks.—Two juvenile females (KU 212314–15) have SVLs of 17.4 and 18.2 mm.

Eleutherodactylus lirellus Dwyer

Eleutherodactylus lirellus Dwyer, 1995:247. Holotype: KU 212240, adult female, from western slope of Abra Tangarana, 1080 m, 7 km [by road] NE San Juan de Pacaysapa, Provincia Lamas, Departamento San Martín, Peru.

Diagnosis.—A member of the *Eleutherodactylus* (*Eleutherodactylus*) *unistrigatus* Group having (1) skin on dorsum coarsely areolate with scattered small tubercles, that on finely areolate; discoidal fold prominent; dorsolateral folds absent; (2) tympanic membrane tympanic annulus not visible; (3) snout subacuminate in dorsal view, rounded in profile; (4) upper eyelid bearing many small tubercles, narrower than IOD; cranial crests absent; (5) vomerine odontophores prominent, oblique; (6) males possessing vocal slits; nuptial pads absent; (7) Finger I shorter than II; discs expanded, about twice width of digit proximal to pad; (8) fingers bearing lateral fringes; (9) ulnar tubercles absent; (10) heel bearing two small tubercles; outer edge of tarsus bearing row of tubercles; inner tarsal tubercles and fold absent; (11) inner metatarsal tubercle elliptical, 4–5× subconical outer metatarsal tubercle; supernumerary plantar tubercles proximally; (12) toes bearing lateral fringes; webbing absent; Toe V much longer than III; discs nearly as large as those on outer fingers; (13) dorsum brown with darker brown markings; groin brown with one pale spot; venter cream with dark flecks; posterior surfaces of thighs dark brown with cream flecks; (14) SVL in males 14.1–17.0 mm, in females 19.4–24.0 mm (Dwyer, 1995).

The absence of a tympanum and tympanic annulus distinguishes *Eleutherodactylus lirellus* from all other species in the northern Andes, except *E. colodactylus*, which differs by lacking vocal slits and having short fingers with round discs. Furthermore, *E. colodactylus* lacks labial and limb bars and a yellow spot in the groin. The latter feature is shared by several species in the upper Amazon Basin. Two of these (*E. toftae* and *E. variabilis*) have a distinct tympanic annulus; *E. carvalhoi* and *E. croceoinguinis* lack vocal slits and lateral fringes on the fingers and toes, and *E. imitatrix* has small yellow spots on the anterior surfaces of

the thighs. Andean species with pale spots in the groin are *E. ceuthospilus*, *muscosus*, and *rufioculis*, all of which have tympanic membranes and distinct tympanic annuli, except *E. rufioculis*, in which the tympanic membrane is absent, and the annulus is evident only ventrally. In the northern Andes, other species having yellow or pale spots in the groin are members of the *Eleutherodactylus orestes* Group; these small frogs have robust bodies, digits with narrow terminal discs, and Toe V only slightly longer than Toe III.

Description.—The description by Dwyer (1995) is adequate.

Distribution and habitat.—*Eleutherodactylus lirellus* is known from three localities at elevations of 470–1200 m on ridges of the eastern slopes of Cordillera Central in northern Peru (Fig. 26). All individuals were found at night on low vegetation in lower montane rainforest.

Remarks.—Dwyer (1995) provided a detailed morphometric analysis of *Eleutherodactylus lirellus* and five Amazonian species that have yellow spots in the groin. However, there is no evidence that the presence of yellow spots in the groin is a synapomorphy.

Eleutherodactylus muscosus new species

Holotype.—KU 219482, adult female, the east slope of Abra Pardo de Miguel (05°46' S, 77°41' W, about 1800 m), Provincia Rioja, Departamento San Martín, Peru, one of a series of four specimens collected on 30 July 1981 by Rainer Schulte.

Paratypes.—KU 209479–80, subadult females, and 209481, an adult female, collected with the holotype.

Diagnosis.—A member of the *Eleutherodactylus* (*Eleutherodactylus*) *unistrigatus* Group having (1) skin on dorsum smooth with scattered, small tubercles, that on venter areolate; discoidal fold not evident; dorsolateral folds absent; (2) tympanic membrane and tympanic annulus distinct, slightly higher than long, its length about 30% length of eye; (3) snout long, bluntly rounded in dorsal view and rounded in profile; (4) upper eyelid narrower than IOD, with one or two round tubercles posteriorly; cranial crests absent; (5) vomerine odontophores prominent, slightly oblique; (6) males unknown; (7) Finger I shorter than II; discs on outer fingers broadly expanded, nearly truncate, more than twice width of digit proximal to pad; (8) fingers bearing narrow lateral fringes; (9) ulnar tubercles low, diffuse; (10) heel bearing conical tubercle; outer edge of tarsus bearing one or two tubercles proximally, inner edge of tarsus lacking tubercles; (11) inner metatarsal tubercle elevated, ovoid, about 3× subconical rounded outer metatarsal tubercle; supernumerary plantar tubercles prominent, in single row on each digit; (12) toes bearing narrow lateral fringes; webbing basal, between

Toes III and IV, and IV and V; Toe V much longer than III; discs slightly smaller than those on outer fingers; (13) dorsum with darker brown markings and with or without narrow, irregular white venation; throat and chest tan with brown reticulations or blotches; belly, groin, posterior surfaces of thighs, and ventral surfaces of hind limbs dark brown with cream spots; (14) SVL in four females 29.6–46.1 mm (\bar{x} = 37.8).

In coloration, *Eleutherodactylus muscosus* is unlike any other species of the genus in the Andes of northern Peru. The pale vermiculations on the dorsum are similar to those exhibited by some specimens of *E. spinosus* (Lynch, 1979:fig. 19), a species that differs in being smaller (females 28.3–34.5 mm) and having a snout that is truncate in profile, elongate tubercles on the upper eyelid, low cranial crests, and subconical ulnar tubercles. Only two other species in the region have tubercles on the upper eyelid and a conical tubercle on the heel; of these, *E. galdi* differs by having an acuminate snout in dorsal view and a uniformly cream venter, and *E. quaquaversus* differs by having elliptical (as opposed to truncate) discs on the fingers and a white venter.

Description.—(n = 4 females). Head as wide as body; HW 39.4–41.0 (\bar{x} = 39.8)% SVL; HL 40.1–43.4 (\bar{x} = 41.9)% SVL; snout moderately long, bluntly rounded in dorsal view, rounded in profile; E–N 80.7–91.0 (\bar{x} = 86.1)% length of eye; nostrils barely protuberant, directed laterally; canthus rostralis angular, barely concave; loreal region deeply weakly concave, sloping abruptly to rounded lips; upper eyelid with one or two rounded tubercles posteriorly; upper eyelid width 67.8–83.3 (\bar{x} = 75.7)% IOD; cranial crests absent; supratympanic fold moderately heavy, obscuring upper part of tympanum; side of head nearly vertical; tympanic annulus thin; tympanic membrane not pustular or thickened; tympanic annulus slightly higher than long; length of tympanic annulus 31.3–38.6 (\bar{x} = 35.9)% length of eye; postrectal tubercles small, subconical, posteroventral to tympanic annulus; skin on head smooth. Choanae small, oval, not concealed by palatal shelf of maxillary arch; vomerine odontophores slightly oblique, posteromedian to choanae, elongately oval in outline, each about 4 \times size of choana, separated medially by distance less than width of odontophore, each bearing 4–6 (\bar{x} = 4.9) teeth; tongue oval, longer than wide, its posterior border not notched, posterior third not adherent to floor of mouth.

Dorsum of head, body, and limbs smooth with scattered, small, subconical tubercles; dorsolateral folds absent; flanks weakly tuberculate; cloacal sheath and enlarged tubercles in cloacal region absent; skin on throat and belly areolate; discoidal fold not evident. Ulnar tubercles few, low, diffuse; thenar tubercle elongately elliptical, about equal in size to bifid palmar tubercle; supernumerary palmar tubercles few, minute; subarticular tu-

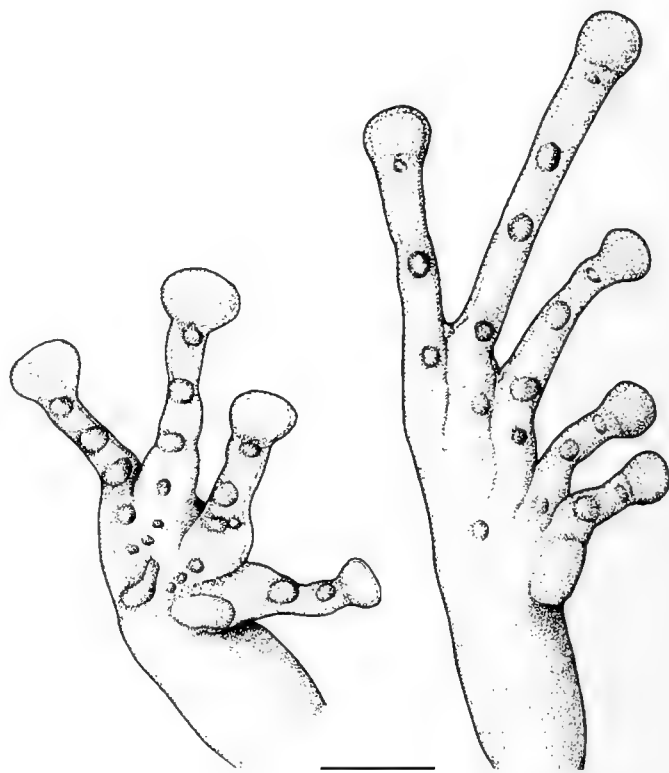

Fig. 27. Hand and foot of *Eleutherodactylus muscosus*, KU 219482. Scale bar = 5 mm.

bercles prominent, round; fingers bearing narrow lateral fringes; first finger shorter than second; disc on thumb expanded, round; discs on Fingers II–IV broadly expanded, nearly truncate, more than twice width of digits (Fig. 27); all fingers having ventral pads defined by circumferential grooves. Upper surfaces of hind limbs smooth; heel bearing conical tubercle; outer edge of tarsus bearing one or two subconical tubercles proximally; inner surfaces of tarsus smooth; inner metatarsal tubercle elevated, ovoid, about 3 \times rounded outer metatarsal tubercle; supernumerary plantar tubercles prominent, in single row on each digit; subarticular tubercles subconical; toes bearing narrow lateral fringes; webbing basal between Toes III and IV and IV and V; discs on toes slightly smaller than those on fingers; tip of Toe V extending beyond distal edge of distal subarticular tubercle on Toe IV; tip of Toe III not extending to that tubercle (Fig. 27); when hind limbs flexed perpendicular to axis of body, heels slightly overlapping; shank 51.0–56.3 (\bar{x} = 53.3)% SVL.

Coloration in preservative: Dorsum grayish brown with darker brown markings consisting of streaks on dorsum of snout, labial bars, diffuse interorbital bar, supratympanic stripe, and transverse bars on limbs (Fig. 28). In two smallest specimens (KU 209479–80, SVLs 32.7 and 29.6 mm) dark transverse marks in scapular and sac-

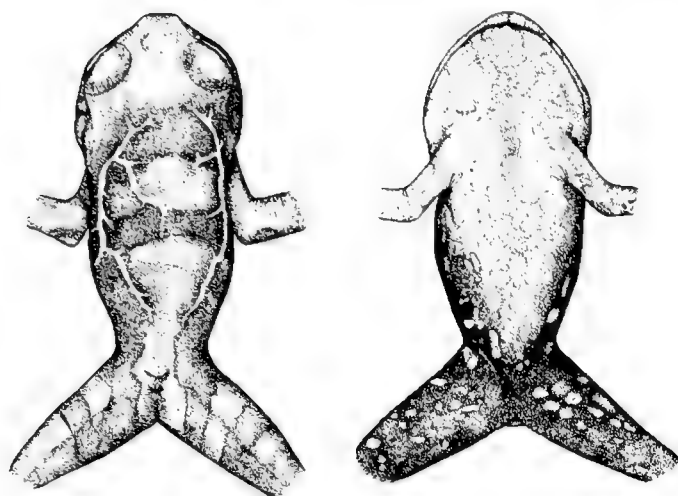

Fig. 28. Dorsal and ventral color pattern of *Eleutherodactylus muscosus*, KU 219462. SVL = 46.1 mm.

ral regions. In two largest specimens (KU 209481–81, SVLs 41.9 and 46.1 mm) dorsum of body pale brown with white vermiculations. Throat and chest of two smallest specimens tan with brown blotches. Throat, chest, and anterior part of belly in two larger specimens tan with fine brown markings nearly forming reticulations; flanks brown with white spots. Posterior part of belly, ventral surfaces of hind limbs, groin, and posterior surfaces of thighs dark brown with cream spots.

Coloration in life: Dorsum green with many brown and black spots and irregular white lines resembling structures made by worms or fly larvae on stones; groin and lower surfaces of hind limbs with orange-yellow spots (R. Schulte, photographs and field notes, 30 July 1981).

Measurements of holotype: SVL 46.1, tibia length 23.1, foot length 24.5, head width 18.3, head length 18.5, IOD 5.9, upper eyelid width 4.0, E–N 4.2, eye 5.2, tympanum 2.0.

Distribution and habitat.—This species is known only from the type locality on the eastern slopes of the northern part of the Cordillera Oriental in northern Peru (Fig. 26). The type locality is a stream with rocky banks in humid, upper montane forest. Stones along the edge of the stream are covered with moss. The frogs were found by day in cavities between stones; according to R. Schulte, the frogs are “imitating exactly a mossy stone.”

Etymology.—The specific name is a Latin adjective *muscosus*, meaning mossy; the name is used in reference to the appearance of the species, as well as its habitat.

Remarks.—The four specimens of this distinctive species are poorly preserved; they died en route from the type locality to the collector’s home in Tarapoto. Consequently, neither the measurements nor the descriptions of certain

morphological structures are as accurate as in our other descriptions. Although Schulte’s field notes imply white vermiculations on all four individuals, they are evident only in the two largest individuals; however, the distinctive ventral coloration is the same in all four specimens.

Eleutherodactylus nephophilus new species

Holotype.—KU 212306, an adult female, the east slope of Abra Pardo de Miguel (05°46' S, 77°42' W, 2180 m, Provincia Rioja, Departamento San Martín, Peru, one of a series of six specimens collected on 31 January 1989 by William E. Duellman, Michael E. Morrison, and John J. Wiens.

Paratypes.—KU 212307–09 from the type locality; KU 217322, an adult female, from 14 km [by road] W Venceremos, 2000 m, Provincia Rioja, Departamento San Martín, Peru.

Referred specimens.—KU 212305 and 212317, juvenile females, from the type locality; KU 212311, juvenile, from the west slope of Abra Tangarana, 7 km [by road] NE San Juan de Pacaysapa, Provincia Lamas, Departamento San Martín, Peru.

Diagnosis.—A member of the *Eleutherodactylus* (*Eleutherodactylus*) *unistrigatus* Group having (1) skin on dorsum smooth with sinusoidal dermal ridges from orbit to scapular region and scattered, small tubercles, that on venter areolate; discoidal fold weak; dorsolateral folds absent; (2) tympanic membrane evident, and tympanic annulus distinct, slightly higher than long, its length only 20–30% length of eye; (3) snout moderately long, rounded in dorsal view and in profile; (4) upper eyelid narrower than IOD, with small tubercles posteriorly; cranial crests absent; (5) vomerine odontophores prominent, oblique; (6) males unknown; (7) Finger I shorter than II; discs on outer fingers nearly truncate, more than twice width of digit proximal to pad; (8) fingers bearing narrow lateral fringes; (9) ulnar tubercles present; (10) heel and outer edge of tarsus bearing tubercles; inner edge of tarsus bearing tubercles tending to coalesce into low ridge; (11) inner metatarsal tubercle ovoid, about 5× subconical outer metatarsal tubercle; supernumerary plantar tubercles prominent; (12) toes bearing narrow lateral fringes; webbing absent; Toe V slightly longer than III; discs slightly smaller than those on outer fingers; (13) dorsum brown with or without darker markings or paler markings; venter tan with dense dark brown flecks; posterior surfaces of thighs brown with cream spots; (14) SVL in five adult females 24.6–34.0 mm (\bar{x} = 29.8).

Eleutherodactylus nephophilus is like the sympatric *E. rufioculis* in having a red iris, but it differs from that smaller species (female = 20.6 mm) in several features—tubercles and ridges on dorsum (smooth in *E. rufioculis*), prominent

tympanum (annulus visible under skin), tubercles on upper eyelid (absent), oblique vomerine odontophores oblique (ovoid), lateral fringes on fingers (absent), ulnar, heel, and tarsal tubercles (absent), dark bars on limbs diagonal (transverse), interorbital bar absent (present), labial bars present (absent), and posterior surfaces of thighs dark with pale spots (pale with dark spots). *Eleutherodactylus nephophilus* is smaller than *E. muscosus* (females to 37.8 mm), which differs by having truncate discs, conical tubercle on the heel, and large pale spots on the flanks and lower surfaces of the hind limbs.

Description.—($n = 5$ females). Head slightly wider than body; HW 37.8–40.0 ($\bar{x} = 39.1$)% SVL; HL 37.8–39.4 ($\bar{x} = 38.1$)% SVL; snout moderately long, rounded in dorsal view, and in profile; E–N 81.8–100.0 ($\bar{x} = 92.5$)% length of eye; nostrils slightly protuberant, directed laterally; canthus rostralis weakly angular, barely concave; loreal region weakly concave sloping abruptly to lips; lips not flared; upper eyelid with small tubercles posteriorly; upper eyelid width 75.8–88.9 ($\bar{x} = 80.4$)% IOD; cranial crests absent; supratympanic fold weak, barely obscuring upper edge of tympanic annulus; side of head nearly vertical; tympanic annulus thin; tympanic membrane not pustular or thickened; tympanic annulus slightly higher than long; length of tympanic annulus 21.2–37.5 ($\bar{x} = 28.4$)% length of eye; postrectal tubercles large, subconical, posteroventral to tympanic annulus; skin on head smooth. Choanae small, oval, not concealed by palatal shelf of maxillary arch; vomerine odontophores oblique, posteromedian to choanae, oval in outline, each about 4× size of choana, separated medially by distance less than width of odontophore, each bearing 3–5 ($\bar{x} = 4.2$) teeth; tongue longer than wide, its posterior border shallowly notched, posterior half not adherent to floor of mouth.

Dorsum of head, body, and limbs smooth with scattered, small, subconical tubercles; tubercles forming sinusoidal ridge from posteromedian edge of eyelid to scapular region; single, conical tubercle on midline anterior to orbits in two individuals; dorsolateral folds absent; flanks tuberculate; cloacal sheath and enlarged tubercles in cloacal region absent; skin on throat and belly areolate; discoidal fold evident posteriorly. Ulnar tubercles few, round to subconical; thenar tubercle ovoid, about ½ size of bifid palmar tubercle; supernumerary palmar tubercles few, minute; subarticular tubercles prominent, subconical; fingers bearing narrow lateral fringes; Finger I shorter than II; disc on thumb barely expanded; discs on Fingers II–IV elliptical, nearly truncate, more than twice width of digits; all fingers having ventral pads defined by circumferential grooves. Upper surfaces of hind limbs smooth with scattered small tubercles; heel bearing subconical tubercle; outer edge of tarsus bearing three or four subconical tu-

bercles; low fold on distal third of inner surfaces of tarsus; inner metatarsal tubercle flat, ovoid, about 5× subconical outer metatarsal tubercle; supernumerary plantar tubercles prominent, round; subarticular tubercles round, not conical; toes bearing weak lateral fringes; webbing absent; discs on toes nearly as large as those on fingers; tip of Toe V extending to distal edge of distal subarticular tubercle on Toe IV; tip of Toe III not extending to that tubercle; when hind limbs flexed perpendicular to axis of body, heels barely overlapping; shank 50.6–55.2 ($\bar{x} = 52.9$)% SVL.

Coloration in preservative: Dorsum brown with a variety of markings—KU 212306: broad, median grayish tan blotches (snout, occipital region, scapular region, and sacral region); KU 212307: broad cream middorsal stripe narrowly bordered by dark brown; KU 212308 and 217322: dark brown dermal ridges in occipital-scapular region; KU 212309: like KU 212308 but with top of head pale tan with faint brown markings. Dorsal surfaces of limbs brown with darker brown diagonal bars narrower than interspaces. Flanks brown with narrow creamy tan diagonal marks or reticulations, especially evident posteriorly; anterior and posterior surfaces of thighs brown with pale cream vertical bars dorsally and spots or reticulations ventrally; distinctive dark cloacal patch absent. Canthal stripe and interorbital bar usually absent (canthal stripe present in KU 217322); three or four dark labial bars; dark postorbital stripe encompassing upper part of tympanum or not. Entire venter tan heavily flecked with brown, reticulate in KU 217322; cream midventral line on chest and belly in KU 212307.

Coloration in life: Dorsal coloration highly variable—KU 212306: mottled yellowish tan, olive-green, and dark dull red; KU 212307: olive with median yellow stripe and orange dorsolateral area (Fig. 10); KU 212308: dull brown; KU 212309: brown with grayish-tan head. Flanks brown (dull red in KU 212306) with cream markings; venter dull yellow to tan with reddish, dark brown, or black flecks or reticulations; iris red.

Measurements of holotype: SVL 29.7, tibia length 15.9, foot length 13.4, head width 11.6, head length 11.4, IOD 3.3, upper eyelid width 2.5, E–N 3.0, eye 3.0, tympanum 1.0.

Distribution and habitat.—The species is known only from three localities at 1080, 2000, and 2180 m along the road from Abra Pardo Miguel to Moyobamba on the east slope of the northern part of the Cordillera Central in northern Peru (Fig. 26). Five adults and two juveniles were on leaves on low vegetation (< 1 m) above the ground in humid montane forest at night; one juvenile was on the ground by day.

Etymology.—The specific name is derived from the Greek *nephos*—meaning cloud and the Greek adjective

philia meaning fondness; the name is applied in reference to the species inhabiting cloud forest.

Remarks.—Three juveniles (KU 212317, 212305, and 212311) have SVLs of 17.1, 16.9, and 9.1 mm, respectively.

Eleutherodactylus ockendeni (Boulenger)

Hylodes ockendeni Boulenger, 1912:187. Syntypes, BM 1907.5.7.19–21 (= 1947.2.16.88–90), from La Unión, Río Huacamayo, Carabaya, Departamento Puno, Peru.

Hylodes hylaeformis Melin, 1941:48. Types, NHMG, from Roque, Departamento San Martín, Peru. Synonymy fide Lynch, 1980.

Syrrhophus calcaratus Andersson, 1945:27. Holotype, NHRM 1941, from Río Cosanga near Archidona, Provincia Napo, Ecuador. Synonymy fide Lynch, 1974:16.

Eleutherodactylus melini Bokermann, 1958:95. Replacement name for *Hylodes hylaeformis* Melin, 1941, non *Phylllobates hylaeformis* Cope, 1875). Synonymy fide Lynch, 1974b:16.

Eleutherodactylus anderssoni Lynch, 1968:292. Replacement name for *Syrrhophus calcaratus* Andersson, 1945, non *Hylodes calcaratus* Boulenger, 1908. Synonymy fide Lynch 1974b:16.

Eleutherodactylus ockendeni—Lynch, 1974b:16; 1980:12.

Diagnosis.—A member of the *Eleutherodactylus* (*Eleutherodactylus*) *unistrigatus* Group having (1) skin on dorsum shagreen with or without W-shaped occipital-scapular ridges and dorsolateral folds, that on venter coarsely areolate; discoidal fold evident; (2) tympanic membrane and tympanic annulus usually prominent, its length about $\frac{1}{4}$ – $\frac{1}{2}$ length of eye; (3) snout short, subacuminate in dorsal view, rounded in profile; (4) upper eyelid usually bearing tubercles, about equal in width to IOD; cranial crests absent; (5) vomerine odontophores, oval, oblique; (6) males having vocal slits, lacking nuptial pads; (7) Finger I shorter than II; discs moderately large, elliptical; (8) fingers having narrow lateral fringes; (9) ulnar tubercles minute; (10) heel bearing rounded tubercle; outer edge of tarsus bearing small tubercles; inner edge of tarsus lacking tubercles or fold; (11) inner metatarsal tubercle elliptical, 4–6 \times round outer metatarsal tubercle; plantar supernumerary tubercles few; (12) toes bearing lateral fringes; webbing absent; Toe V much longer than III; discs as large as those on fingers; (13) dorsum cream to brown with brown to black interorbital bar, subocular spots, supratympanic stripe, dorsal chevrons, and bar posterior to sacrum; posterior surfaces of thighs uniform brown; venter white with or without brown flecks; (14) SVL in males 16.9–21.2 mm, in females 24.6–31.5 mm (Lynch, 1980, for Amazonian Peru).

The presence of a W-shaped scapular mark on an otherwise plain pale brown dorsum is shared with *Eleutherodactylus percnopterus*, which lacks vomerine odontophores and has a dark canthal stripe. Four other members of the *Eleutherodactylus unistrigatus* Group in the region may have a W-shaped scapular mark; three of these (*E. exoristus*, *incomptus*, and *sternothylax*) have diagonal bars or streaks on the flanks, whereas *E. bearsei* has cream flecks

on the flanks, and *E. cryptomelas* has black in the groin and on the anterior surfaces of the thighs.

Description.—The description by Lynch (1974b) was augmented by that of Lynch (1980).

Distribution and habitat.—*Eleutherodactylus ockendeni* is distributed throughout the upper Amazon Basin from southern Colombia to southern Peru. A few records indicate that the species ascends to slopes of the Andes to moderate elevations. The species was reported from 1140–1150 m on the eastern slopes of the Cordillera Oriental (Lynch and Duellman, 1980) and from Miaza, 900 m, on the western slope of the Cordillera del Cóndor (Almendáriz, 1997) in Ecuador, and from 1100–1280 m in the Serranía de Sira, Departamento Huánuco, Peru (Duellman and Toft, 1979). A single specimen from 4 km SW of Chiriaco, 725 m, Provincia Bagua, Departamento Amazonas, Peru, documents the occurrence of *E. ockendeni* in the Río Marañón Valley in the Andes of northern Peru (Fig. 26).

Remarks.—The specimen (KU 196470) from the Río Marañón Valley is a female having a SVL of 26.0 mm.

Eleutherodactylus pecki Duellman and Lynch

Eleutherodactylus pecki Duellman and Lynch, 1988:135. Holotype: KU 147040, adult male, from the Río Piuntza, 1550 m, Cordillera del Cóndor, Provincia Morona-Santiago, Ecuador.

Diagnosis.—A member of the *Eleutherodactylus* (*Eleutherodactylus*) *unistrigatus* Group having (1) skin on dorsum smooth with small tubercles on flanks, posterior part of back, and upper surfaces of limbs, that on venter areolate; discoidal fold evident; dorsolateral folds absent; (2) tympanic membrane and tympanic annulus prominent, its length about 32% length of eye; (3) snout short, subacuminate in dorsal view, rounded in profile; canthus rostralis rounded; (4) upper eyelid bearing tubercles, equal in width to IOD; cranial crests absent; (5) vomerine odontophores small, oval; (6) males having vocal slits and white, nonspinous nuptial pads; (7) Finger I shorter than II; discs moderately large, round; (8) fingers having weak lateral fringes; (9) ulnar tubercles absent; (10) heel bearing small tubercle; outer edge of tarsus lacking tubercles; inner edge of tarsus bearing elongate tubercle; (11) inner metatarsal tubercle oval, 3–4 \times round outer metatarsal tubercle; plantar supernumerary tubercles numerous; (12) toes bearing lateral fringes; webbing absent; Toe V longer than III; discs smaller than those on fingers; (13) dorsum brown, darkest laterally; venter cream; (14) SVL in males 15.3–18.7 mm, in female 25.2 mm.

As noted by Duellman and Lynch (1988), *Eleutherodactylus pecki* is most similar to *E. incomptus* and the lowland *E. martiae*. It differs from *E. incomptus* by having a tubercle on the heel and tubercles on the upper eye-

lid, and it differs from *E. martiae* by being larger (males of *E. pecki* being as large as females of *E. martiae*) and in having a prominent tympanum. Of the other species in northern Peru having tubercles on the upper eyelids and small tubercles on the heels, *E. bromeliaceus*, *cryptomelas*, *lirellus*, *nephophilus*, and *rhodoplichus* differ from *E. pecki* in having the discs on the outer fingers being elliptical (much broader than long) instead of nearly rounded. Rounded terminal discs also are present in *E. colodactylus* and *E. schultei*, both of which have tubercles on upper eyelids and small tubercles on the heels. *Eleutherodactylus colodactylus* differs by lacking a tympanum, vocal slits, and nuptial pads. *Eleutherodactylus schultei* differs by being much larger (males > 25 mm; females > 28 mm), by having the snout inclined posteroventrally in profile (rounded in *E. pecki*), and in coloration.

Description.—The original description by Duellman and Lynch (1988) is expanded by the addition of a female (USNM 525476) having a SVL of 25.2 mm. Comparison of this specimen with the holotype and two paratypes (KU 147041–42) reveals that in the female the tubercles on the eyelids of smaller and lower than those in the type series; furthermore, the tubercles on the heels are barely discernible. The coloration of the female resembles the males in the type series. The dorsum is tan with three diffuse longitudinal, brown streaks and diffuse dark brown dorsolateral stripes. The flanks and hidden surfaces of the thighs are dark brown, and the venter is heavily flecked with brown. A dark brown canthal stripe and two brown labial bars are present, but an interorbital bar is absent.

Distribution and habitat.—This species is known from elevations of 1700 m in the Cordillera de Cutucú, 1550 m on the western slopes of the Cordillera del Cóndor, and 1138 m on the eastern slopes of the Cordillera del Cóndor (Fig. 26). The last locality is the only record for the species in Peru; the specimen was on a leaf 2 m above the ground at night in lower montane rainforest.

Remarks.—Duellman and Lynch (1988) suggested that *Eleutherodactylus frater*, *incomptus*, and *pecki* were allopatric variants of *E. ockendeni* in the lowlands of the upper Amazon Basin. The latter is known from elevations as high as 1150 m in the Cordillera del Dué in Ecuador, 1280 m in the Serranía de Sira in Peru (Lynch and Duellman, 1980), and 900 m on the western slope of the Cordillera del Cóndor in Ecuador (Almendáriz, 1997). Likewise, Flores and Vigle (1994) considered *E. librarius*, which is sympatric with *E. ockendeni* in the upper Amazon Basin in Ecuador, to be closely related to *E. ockendeni*.

Eleutherodactylus percnopterus new species

Holotype.—KU 217318, adult female, from Santa Rosa de la Yunga (06°05' S, 78°43' W, 1300 m), Provincia Jaén,

Departamento Cajamarca, Peru, obtained on 15 July 1989 by Weyder Razzetto and Walter A. Alarcón.

Paratypes.—KU 196505 and LSU 32462–63, adult males, from 33 km [by road] SE Ingenio, 1830 m, Provincia Chachapoyas, Departamento Amazonas, Peru.

Referred specimens.—KU 196506, subadult male, from 20 km [by road] SW Chiriaco, Provincia Bagua, Departamento Amazonas, Peru; KU 209472, subadult female, from pass at 2400 m, 5 km [by road] NW Mendoza, Provincia Rodríguez de Mendoza, Departamento Amazonas, Peru. USNM 525443, juvenile, from the upper Río Comainas at base of Cerro Machinaza, 1750 m, Provincia Condorcanqui, Departamento Amazonas, Peru; USNM 525445–46, 525449–63 from Alfonso Ugarte, 1138 m, Provincia Condorcanqui, Departamento Amazonas, Peru.

Diagnosis.—A member of the *Eleutherodactylus (Eleutherodactylus) unistrigatus* Group having (1) skin on dorsum with few small tubercles, that on venter weakly areolate; discoidal fold prominent; dorsolateral folds absent; (2) tympanic membrane present; tympanic annulus distinct, round, its diameter about 40% length of eye; (3) snout moderately long, subacuminate in dorsal view, rounded in profile; (4) upper eyelid narrower than IOD, with or without low tubercles; cranial crests absent; (5) vomerine odontophores absent; (6) males having vocal slits, lacking nuptial pads; (7) Finger I shorter than II; discs on outer fingers nearly truncate, more than twice width of digit proximal to pad; (8) fingers lacking distinct lateral fringes; (9) ulnar tubercles absent; (10) heel and tarsus lacking tubercles; (11) inner metatarsal tubercle, elevated, elliptical, about 5× subconical outer metatarsal tubercle; supernumerary plantar tubercles low, rounded; (12) toes lacking lateral fringes; webbing absent; Toe V much longer than III; discs nearly as large as those on outer fingers; (13) dorsum pale brown with dark brown marks in scapular region; venter tan with fine dark brown flecks; posterior surfaces of thighs tan; (14) SVL in three adult males 21.5–23.2 (\bar{x} = 22.5) mm, in one adult female 25.9 mm.

Eleutherodactylus percnopterus is most easily confused with *E. incomptus*, which is similar in size and also lacks vomerine odontophores (except in large females); the latter differs from *E. percnopterus* by having the snout rounded in dorsal view, discs on fingers rounded, digits bearing narrow lateral fringes, inner edge of tarsus bearing one or two tubercles, and males having nuptial pads. Furthermore, in *E. incomptus*, dorsal markings are more extensive and contrasting with the ground color, and the venter is brown. The only other member of the *Eleutherodactylus unistrigatus* Group in the Andes of northern Peru that lacks vomerine odontophores is *E. anemerus*, a frog that lacks

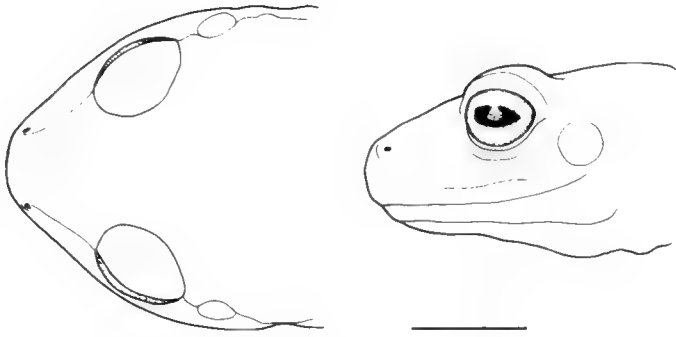

Fig. 29. Dorsal and lateral views of the head of *Eleutherodactylus percnopterus*, KU 217318. Scale bar = 5 mm.

dorsal markings, has an orange-red dorsum, yellow flanks, and a prominent tubercles on the snout. The presence of scapular marks on an otherwise plain pale brown dorsum is shared with the primarily Amazonian *E. ockendeni*, which has vomerine odontophores and lacks a dark canthal stripe. In its absence of distinctive features, *E. percnopterus* is like *E. pecki*, which differs from the former by having vomerine odontophores, a small tubercle on the heel and a dark venter. Three other species in the region that lack vomerine odontophores (*E. atrabracus*, *melanogaster*, and *pataikos*) are robust-bodied members of the *E. orestes* group that have small terminal discs on the fingers, short hind limbs, and Toe V only slightly longer than Toe III.

Description.—($n = 3$ males, 1 female; proportions are for males, followed by those of the female). Head as wide as body; HW 35.8–36.3 ($\bar{x} = 36.1$), 39.4% SVL; HL 35.8–37.6 ($\bar{x} = 37.0$), 38.6% SVL; snout moderately long, subacuminate in dorsal view, rounded in profile (Fig. 29); E–N 70.1–100.0 ($\bar{x} = 89.6$), 90.0% length of eye; nostrils barely protuberant, directed laterally; canthus rostralis rounded, curved; loreal region concave; lips slightly flared; upper eyelid with low tubercles in males; upper eyelid width 64.2–87.5 ($\bar{x} = 73.9$), 69.4% IOD; cranial crests absent; supratympanic fold weak, barely obscuring upper edge of tympanic annulus; side of head slightly inclined ventrolaterally; tympanic annulus thin; tympanic membrane not pustular or thickened; tympanic annulus round; diameter of tympanic annulus 37.0–44.0 ($\bar{x} = 41.0$), 46.6% length of eye; postriatal tubercles low, diffuse. Choanae moderately large, ovoid, not concealed by palatal shelf of maxillary arch; vomerine odontophores absent; tongue longer than wide, its posterior border distinctly notched, posterior half not adherent to floor of mouth. Males with vocal slits extending posterolaterally from midlateral base of tongue; vocal sac single, median, subgular; nuptial pads absent.

Dorsum of head and body smooth with scattered, small, subconical tubercles; dorsal surfaces of limbs with

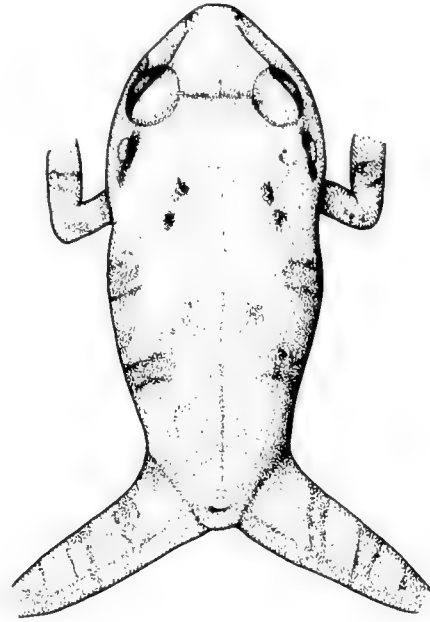

Fig. 30. Dorsal color pattern of *Eleutherodactylus percnopterus*, KU 217318. SVL = 25.9 mm.

low tubercles; dorsolateral folds absent; flanks smooth; cloacal sheath and enlarged tubercles in cloacal region absent; skin on throat weakly areolate, on belly and ventral surfaces of thighs coarsely areolate; discoidal fold prominent. Ulnar tubercles absent; thenar tubercle broadly ovoid, elevated more than $\frac{1}{2}$ size of bifurcate palmar tubercle; supernumerary palmar tubercles absent; subarticular tubercles prominent, subconical; fingers lacking distinct lateral fringes; Finger I shorter than II; disc on thumb barely expanded; discs on fingers broadly elliptical, nearly twice width of digit proximal to disc; all fingers having ventral pads defined by circumferential grooves. Heel and tarsus lacking tubercles; inner metatarsal tubercle elevated, elliptical, about 5 \times subconical outer metatarsal tubercle; supernumerary plantar tubercles low, rounded; subarticular tubercles subconical; toes lacking lateral fringes; webbing absent; discs on toes nearly as large as those on fingers; tip of Toe V extending to distal edge of distal subarticular tubercle on Toe IV; tip of Toe III extending to distal edge of penultimate subarticular tubercle on Toe IV; when hind limbs flexed perpendicular to axis of body, heels barely overlapping; shank 55.3–56.8 ($\bar{x} = 55.9$), 54.4% SVL.

Coloration in preservative: Dorsum pale brown with narrow, dark brown canthal and supratympanic stripes, faint brown labial bars and interorbital bar, faint brown diagonal bars on limbs, and pair of small black spots or short streaks in scapular region (Fig. 30); flanks, groin, and hidden surfaces of thighs uniform pale brown; venter creamy tan with minute dark flecks on throat and belly.

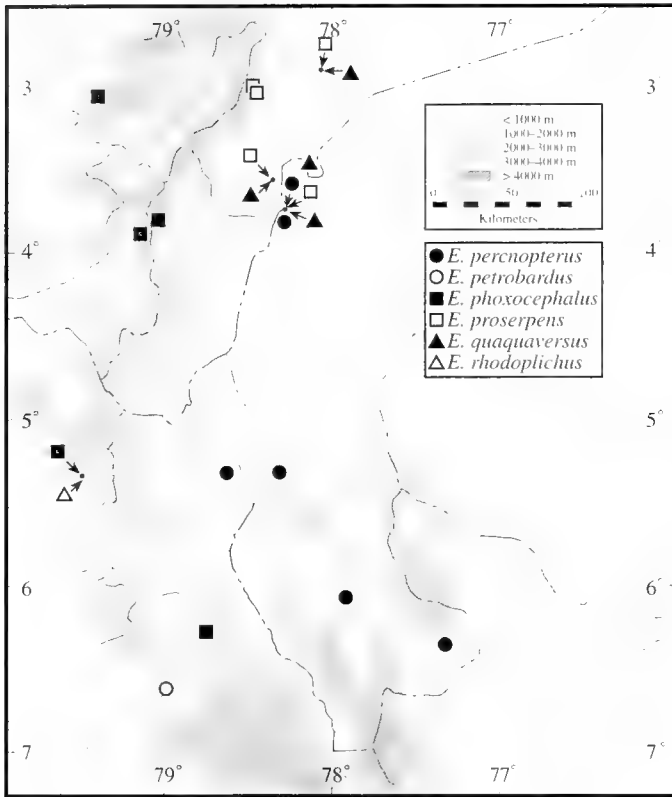

Fig. 31. Localities of known occurrence of six species in the *Eleutherodactylus unistrigatus* group in southern Ecuador and northern Peru.

Coloration in life: KU 217318: Dorsum pale grayish brown with reddish tint on head and small black spots; venter whitish gray (Rainer Schulte field notes, 15 July 1989).

Measurements of holotype: SVL 25.9, tibia length 14.1, foot length 12.7, head width 10.2, head length 10.0, IOD 3.6, upper eyelid width 2.5, E–N 2.7, eye 3.0, tympanum 1.9.

Distribution and habitat.—The species is known from two localities at elevations of 1138 m and 1750 m on the eastern slopes of the Cordillera del Cóndor, and one locality at 1300 m on the southern edge of the Cordillera del Cóndor (Fig. 31). The species also is known at elevations of 1830 and 2400 m in the northern part of the Cordillera Central in Peru. The latter is a pass northwest of Mendoza at the headwaters of the Río Chiriaco; the type locality also is in the Río Chiriaco Drainage. The locality 20 km SW Chiriaco is at an elevation of less than 1000 m in the arid Río Marañón Valley. Thus, the known elevational distribution is at least 1400 m and suggests that the species may have a continuous distribution between the Cordillera del Cóndor and the Cordillera Central. The holotype was in an arboreal bromeliad by day in semiarid forest. Specimens from the eastern slopes of the Cordillera del Condor were on low vegetation at night in humid montane forest.

Etymology.—The specific name is the Greek noun *perknopteros* meaning vulture; the name is in loose reference to *Vultur gryphus*, the Andean condor, to which the Cordillera del Cóndor refers.

Remarks.—The paratypes were collected by Richard Thomas on 21–22 December 1974. One (KU 196505) was calling. The call consists of 2–5 notes (“pink”) followed or not by an ascending series of 10 or more ratchetlike clicks (Richard Thomas field notes, 21 December 1974). The subadult male from 20 km SW Chiriaco (KU 196506), has a SVL of 18.5 mm, and a subadult female from 5 km [by road] NW of Mendoza (KU 209472) has a SVL of 21.6 mm. Both have color patterns like those of the type series. Of the specimens from eastern slopes of the Cordillera del Cóndor, five subadult females have SVLs of 18.7–21.0 (\bar{x} = 20.1) mm, and 13 juveniles having SVLs of 10.7–16.0 (\bar{x} = 14.6) mm. The juveniles tend to be more boldly patterned than the adults.

Eleutherodactylus petrobardus Duellman

Eleutherodactylus petrobardus Duellman, 1991a:6. Holotype: KU 212292, adult male, from approximately 2 km [by road] W Huambos, 2500 m, Provincia Chota, Departamento Cajamarca, Peru.

Diagnosis.—A member of the *Eleutherodactylus* (*Eleutherodactylus*) *unistrigatus* Group having (1) skin on dorsum, flanks, and limbs with small, irregularly arranged pustules, that on venter areolate; discoidal fold evident; dorsolateral folds absent; (2) tympanic membrane and tympanic annulus distinct, round, its length about 45% length of eye; (3) snout rounded in dorsal view and in profile; canthus rostralis rounded; (4) upper eyelid lacking tubercles, slightly narrower than IOD; cranial crests absent; (5) vomerine odontophores oblique, prominent; (6) males having vocal slits but no nuptial pads; (7) Finger I shorter than II; discs broad; (8) fingers bearing lateral fringes; (9) ulnar tubercles low, diffuse; (10) heel bearing small tubercles; outer edge of tarsus lacking tubercles; inner edge of tarsus bearing elongate tubercle; (11) inner metatarsal tubercle ovoid, 3–4× conical outer metatarsal tubercle; plantar supernumerary tubercles small; (12) toes bearing lateral fringes; webbing absent; Toe V much longer than III; discs as large as those on fingers; (13) dorsum tan with irregular brown markings, with or without white spots; venter cream; (14) SVL in males 27.0–30.7 mm, unknown in females.

Of the species in the *Eleutherodactylus unistrigatus* Group in the Andes of northern Peru, *Eleutherodactylus petrobardus* is most similar to the smaller *E. versicolor*, a species that differs by lacking vocal slits and a small tubercle on the heel, and by having brown reticulation on the venter, whereas the belly is white with black flecks in *E. petrobardus*. Also, *E. petrobardus* has more pustular skin on the dorsum than do other species in the region (Fig. 10).

Description.—The description by Duellman (1991) is adequate.

Distribution and habitat.—This species is known only from the type locality in dry scrub forest on the Pacific slopes of the Cordillera Occidental in Departamento Cajamarca, Peru (Fig. 31). Individuals were in terrestrial bromeliads or calling from rock ledges at night.

Eleutherodactylus phoxocephalus Lynch

Eleutherodactylus phoxocephalus Lynch, 1979:29. Holotype: KU 142075, adult male, from Pilaló, 2340 m, Provincia Cotopaxi, Ecuador.

Diagnosis.—A member of the *Eleutherodactylus* (*Eleutherodactylus*) *unistrigatus* Group having (1) skin on dorsum shagreen, that on venter areolate; discoidal fold prominent; dorsolateral folds absent; (2) tympanic membrane and tympanic annulus evident, round, its length no more than $\frac{1}{2}$ length of eye; (3) snout rounded in dorsal view but with vertical fleshy keel, subacuminate in profile; canthus rostralis rounded; (4) upper eyelid lacking tubercles, narrower than IOD; cranial crests absent; (5) vomerine odontophores oblique, prominent; (6) males having vocal slits and nuptial pads; (7) Finger I shorter than II; discs broad; (8) fingers bearing lateral fringes; (9) ulnar tubercles absent; (10) heel and tarsus lacking tubercles and folds; (11) inner metatarsal tubercle oval, 4–6 \times round outer metatarsal tubercle; plantar supernumerary tubercles at bases of Toes II–IV; (12) toes bearing lateral fringes; webbing absent; Toe V much longer than III; discs as large as those on fingers; (13) dorsum gray to brown with few or no darker markings; venter cream; lower flank, groin, and concealed surfaces of limbs white with or without brown or black reticulations; (14) SVL in males 22.3–29.9 mm, in females 29.6–38.9 mm.

Structurally, *Eleutherodactylus phoxocephalus* is unique in the region by having a vertical keel on the snout, which is difficult to discern in some specimens. However, dark reticulations in the groin and on the posterior surfaces of the thighs distinguish *E. phoxocephalus* from congeners in the region, except *E. rhodoplichus*, which differs by having a small tubercle on the heel and by lacking vomerine odontophores.

Description.—The original description by Lynch (1979) is complete, and includes color in life of specimens from provincias Cotopaxi and Loja, Ecuador. Coloration of living individuals from provincias Cotopaxi and Pichincha, Ecuador, were given by Lynch and Duellman (1997) and for two individuals from Departamento Piura, Peru, by Duellman and Wild (1993).

Distribution and ecology.—This species occurs in upper humid montane forest and subparamo at elevations of 1800–3100 m on the Pacific slopes of the Cordillera Occidental in Ecuador and the Andes of southern Ecuador.

In Peru, it is known from only two localities—15 km [by road] ENE Canchaque, 1850 m (KU 181271) and El Tambo, 2770 m (MHNSM 15399)—on the western slopes of the Cordillera de Huancabamba, Departamento Piura, and from San Andres de Cutervo, about 1800 m, in the northern part of the Cordillera Occidental in Departamento Cajamarca (Fig. 31). In the Cordillera de Huancabamba, one individual was on a mossy cliff at night and another was calling at night from low vegetation. In Ecuador, many individuals have been found in the axils of elephant ear plants and arboreal bromeliads by day.

Remarks.—Four specimens (KU 221710–13) were collected at San Andres de Cutervo, Provincia Cutervo, Departamento Cajamarca, Peru, by Alfonso Miranda on 25 June 1992 and 1 April 1993. Of these, one female has a SVL of 38.9 mm, and three males have SVLs of 26.6–27.8 (\bar{x} = 27.2) mm. All specimens have a fleshy vertical keel on the snout; the keel is less pronounced in the female than in the males. The dorsum is brown (female) or tan (males) with dark brown canthal and supratympanic stripes and irregular interorbital bar. The female and one male have numerous small dark brown spots on the dorsum of the head and body anterior to the sacrum; one male has a pair of dark spots in the scapular region, and the other male has many small dark spots in the scapular region and a pair of spots in the sacral region. The venter is cream with minute dark flecks, and the groin and hidden surfaces of the thighs are uniform tan.

Structurally, these specimens compare favorably with two individuals (KU 181271 and MHNSM 15399) from the Cordillera de Huancabamba and with several series from the southern part of the range in Ecuador—Provincia Azuay (KU 131281–82), Provincia Cañar (KU 142118–31), Provincia Loja (KU 135460–62, 142113–17), and Provincia Zamora-Chinchipec (KU 142104–12). However, there are some minor differences in coloration between the Peruvian and Ecuadorian specimens. One of the specimens from the Cordillera de Huancabamba (MHNSM 15399) and all four from San Andres de Cutervo have minute dark flecks over the entire venter, as opposed to small brown spots or more dense flecking in the Ecuadorian specimens, most all of which have dark mottling in the groin and hidden surfaces of the thighs.

Eleutherodactylus proserpens Lynch

Eleutherodactylus proserpens Lynch, 1979:32. Holotype: USNM 198484, adult female, from between Sapote and Suro Rancho, 2622 m, Provincia Morona-Santiago, Ecuador.

Diagnosis.—A member of the *Eleutherodactylus* (*Eleutherodactylus*) *unistrigatus* Group having (1) skin on dorsum and venter areolate; discoidal fold and dorsolateral folds absent; cloacal sheath extending onto posterior surfaces of thighs (2) tympanic membrane and tympanic

annulus prominent, round, its length no more than $\frac{1}{2}$ length of eye; (3) snout long, subacuminate in dorsal view, rounded in profile; small papilla at tip of snout; (4) upper eyelid bearing low, round tubercles, narrower than IOD; cranial crests absent; (5) vomerine odontophores low, oval; (6) males lacking vocal slits and nuptial pads; (7) Finger I shorter than II; fingers short, broad, with round discs only slightly wider than digit proximal to pad; (8) fingers bearing ridgelike lateral fringes; (9) ulnar tubercles absent; (10) heel and tarsus lacking tubercles; (11) inner metatarsal tubercle elliptical, 2 \times round outer metatarsal tubercle; plantar supernumerary tubercles numerous, some nearly as large as subarticular tubercles; (12) toes bearing ridgelike lateral fringes; webbing basal, coalesced with lateral fringes; Toe V much longer than III; discs slightly smaller than those on fingers; (13) dorsum tan to brown with darker brown markings—interorbital bar, supratympanic stripe, limb bars, and X-shaped mark or large, elongate blotch on back—or pale dorsolateral stripe; posterior surfaces of thighs cream to brown; venter pale brown; (14) SVL in males 15.2–21.0 mm, in females 20.2–23.5 mm (Lynch, 1979).

In the region under consideration, only *Eleutherodactylus colodactylus* is like *E. proserpens* in having short, stocky fingers, but *E. proserpens* differs from *E. colodactylus* by having a cloacal sheath, tympanic membrane and annulus, a tubercle on the tip of the snout, and prominent vomerine odontophores. The only other species in the region with a tubercle on the tip of the snout is *E. anemerus*, which has a unicolor dorsum and lacks a tubercle on the heel and vomerine odontophores. In other *Eleutherodactylus* in the region having digital pads that are only slightly broader than the digit proximal to the pad (*E. atrabracus*, *melanogaster*, *pataikos*, and *pinguis*), the fingers are proportionately longer and more slender than those in *E. colodactylus* and *E. proserpens*; moreover, in those robust-bodied species, Toe V is only slightly longer than Toe III.

Description.—The description by Lynch (1979), which includes illustrations of the head and hand, is adequate.

Distribution and habitat.—In Ecuador, this species is known from elevations of 1710–2620 m in the southern part of the Cordillera Oriental, from 1700 m in the Cordillera de Cutucú, and from 1550 m on the western slope of the Cordillera del Cóndor (Duellman and Lynch, 1988; Lynch, 1979). The only Peruvian record is from the upper Río Comainas at the base of Cerro Machinaza, 1750 m, on the eastern slopes of the Cordillera del Condor, Provincia Cordoncanqui, Departamento Amazonas (Fig. 31). All specimens have been found in bromeliads in humid montane forest.

Remarks.—The single Peruvian specimen (USNM 525447) is a juvenile having a SVL of 11.6 mm. Despite its

small size, it has the distinguishing characteristics of *Eleutherodactylus proserpens*—small hands, papilla on snout, and cloacal sheath. In preservative, the dorsum is grayish tan with a large, dark brown, middorsal blotch extending from the anterior edges of the orbits to the sacrum. Dark brown canthal and supratympanic stripes and transverse bars on the limbs are present; labial bars are absent. The venter is heavily flecked with brown.

Eleutherodactylus quaquaversus Lynch

Eleutherodactylus quaquaversus Lynch, 1974b:9. Holotype: KU 123745, adult female, from south slope Cordillera del Dué, above Río Coca, Provincia Napo, Ecuador.

Diagnosis.—A member of the *Eleutherodactylus* (*Eleutherodactylus*) *unistrigatus* Group having (1) skin on dorsum shagreen, that on venter areolate; discoidal fold prominent; dorsolateral folds absent; (2) tympanic membrane absent; tympanic annulus absent or evident only ventrally; (3) snout subacuminate in dorsal view, rounded or weakly pointed in profile; (4) upper eyelid bearing conical tubercle, slightly narrower than IOD; cranial crests absent; (5) vomerine odontophores prominent, triangular; (6) males having vocal slits but lacking nuptial pads; (7) Finger I shorter than II; discs broad, elliptical; (8) fingers bearing lateral fringes; (9) ulnar tubercles absent; (10) heel bearing conical tubercle; outer and inner edges of tarsus bearing small tubercles; (11) inner metatarsal tubercle elliptical, 4–5 \times rounded outer metatarsal tubercle; plantar supernumerary tubercles few; (12) toes bearing narrow lateral fringes; webbing absent; Toe V much longer than III; discs as large as those on fingers; (13) dorsum pale brown to reddish brown with darker brown interorbital bar, chevrons or spots, and narrow diagonal bars on limbs; canthal and supratympanic stripes absent; labial bars variably present; posterior surfaces of thighs reddish brown with brown reticulations; venter white, with or without brown spots; (14) SVL in males 19.6–22.5 mm, in females 24.6–31.3 mm (Lynch and Duellman, 1980).

Of the species in the Andes in northern Peru, *Eleutherodactylus quaquaversus* is like *E. galdi* in having a conical tubercle on the upper eyelid and a conical tubercle on the heel, but the predominately green *E. galdi* has a prominent tympanum, cranial crests, a row of tubercles along the outer edge of the tarsus and foot, and larger, truncate discs on the fingers. *Eleutherodactylus quaquaversus* is superficially similar to *E. ockendeni* and *E. percnopterus*, both of which have well-defined tympana and usually a W-shaped mark in the scapular region (never present in *E. quaquaversus*), and they lack conical tubercles on the upper eyelids and heels and lack brown reticulations on the posterior surfaces of the thighs.

Description.—The original description by Lynch (1974b) was augmented by Duellman (1978c) and Lynch and Duellman (1980).

Distribution and habitat.—Although *Eleutherodactylus quaquaversus* occurs at elevations as low as 200 m in the Amazonian lowlands of Peru (Duellman and Mendelson, 1995), the species is distributed primarily on the eastern slopes of the Andes, where it is known in Ecuador from elevations of 920–1740 m in the Cordillera Oriental (Lynch and Duellman, 1980), 1700 m in the Cordillera de Cutucú (Duellman and Lynch, 1988), and 1500–1550 m on the western slopes of the Cordillera del Cóndor (Almendáriz, 1997; Lynch and Duellman, 1980). We now report the species from the eastern slopes of the Cordillera del Cóndor—upper Río Comainas, base of Cerro Machinaza, 1750 m, Provincia Condorcanqui, Departamento Amazonas, Peru (Fig. 31). Nearly all individuals have been found on low vegetation at night.

Remarks.—In life, juvenile (USNM 525444) with a SVL of 14.8 mm from the upper Río Comainas was described as: “dorsum tan; brown bar between orbits; lips barred; two spots on scapula; legs barred; chin gray; belly green.” (Robert P. Reynolds field notes, 18 July 1994).

Eleutherodactylus rhodoplichus Duellman and Wild

Eleutherodactylus rhodoplichus Duellman and Wild, 1993:13. Holotype: KU 219786, adult male, from El Tambo, 2770 m, 31 km [by road] ENE Canchaque, Provincia Huancabamba, Departamento Piura, Peru.

Diagnosis.—A member of the *Eleutherodactylus (Eleutherodactylus) unistrigatus* Group having (1) skin on dorsum coarsely shagreen, bearing scattered low, round or subconical tubercles, that on venter areolate; discoidal fold prominent; dorsolateral folds absent; (2) tympanic membrane and tympanic annulus prominent, round, its length no more than 60% length of eye; (3) snout subacuminate in dorsal view, rounded in profile; canthus rostralis rounded; (4) upper eyelid bearing low, round tubercles, narrower than IOD; cranial crests absent; (5) vomerine odontophores absent in males in most females, small and elliptical in other females; (6) males having vocal slits but lacking nuptial pads; (7) Finger I shorter than II; discs broad, elliptical; (8) fingers bearing lateral fringes; (9) ulnar tubercles few, low; (10) heel bearing small, subconical tubercles; outer edge of tarsus bearing round, diffuse tubercles; inner edge of tarsus bearing fold; (11) inner metatarsal tubercle elliptical, 3× conical outer metatarsal tubercle; plantar supernumerary tubercles numerous, low, round; (12) toes bearing lateral fringes; webbing absent; Toe V much longer than III; discs slightly smaller than those on fingers; (13) dorsum brown with fine, irregular darker brown markings; venter cream to tan with dark brown flecks; (14) SVL in males 21.8–28.9 mm, in females 30.1–34.2 mm.

Of the other species in the *Eleutherodactylus unistrigatus* Group in the Andes of northern Peru, only *E. anemerus*, *E. incomptus*, and *E. percnopterus* lack vomerine odontophores.

Eleutherodactylus anemerus differs by lacking dorsal markings and having a tubercle on the tip of the snout; both *E. incomptus* and *E. percnopterus* lack the small tubercle on the heel that is present in *E. rhodoplichus* (Fig. 10), and *E. incomptus* also differs by being much smaller and by lacking tubercles on the upper eyelid.

Description.—The description by Duellman and Wild (1993) is adequate.

Distribution and habitat.—This species is known only from elevations of 2770–3050 m in humid montane forest on the western slopes and crest of the Cordillera de Huancabamba (Fig. 31). Individuals were found at night on low vegetation and under rocks by day.

Eleutherodactylus rhodostichus new species

Holotype.—KU 212264, an adult male, from the west slope of Abra Tangarana, 1080 m, 7 km [by road] NE San Juan de Pacaysapa, Provincia Lamas, Departamento San Martín, Peru, one of a series collected on 5 February 1989 by William E. Duellman and Rainer Schulte.

Paratypes.—KU 212265–67 collected with the holotype.

Diagnosis.—A member of the *Eleutherodactylus (Eleutherodactylus) unistrigatus* Group having (1) skin on dorsum finely shagreen with scattered, small tubercles, that on venter areolate; discoidal fold prominent; dorsolateral folds absent; (2) tympanic membrane evident, and tympanic annulus distinct, round, its diameter about 40% length of eye; (3) snout long, acuminate in dorsal view, acutely rounded above and inclined posteroventrally in profile; (4) upper eyelid narrower than IOD, with low tubercles posterolaterally; cranial crests absent; (5) vomerine odontophores low, ovoid; (6) males having vocal slits, lacking nuptial pads; (7) Finger I shorter than II; discs on outer fingers rounded, less than twice width of digit proximal to pad; (8) fingers bearing distinct lateral fringes; (9) ulnar tubercles present; (10) heel lacking tubercles; outer and inner edges of tarsus bearing small tubercles; (11) inner metatarsal tubercle elliptical, about 4× subconical outer metatarsal tubercle; supernumerary plantar tubercles numerous; (12) toes bearing narrow lateral fringes; webbing absent; Yoe V much longer than III; discs nearly as large as those on outer fingers; (13) dorsum tan with brown markings; venter tan with fine dark brown flecks; posterior surfaces of thighs tan; (14) SVL in an adult male 19.3 mm and a subadult female 19.7 mm.

By having a snout that is acuminate in dorsal view and inclined posteroventrally in profile, *Eleutherodactylus rhodostichus* differs from all other members of the genus in the region, except *E. acuminatus* and *E. schultei*, both of which lack a pattern on the dorsum. Furthermore, *E. acuminatus* differs by lacking a tympanic membrane, and

E. schultei differs by having a small tubercle on the heel. Red streaks on the dorsum of the body in living individuals also distinguish *E. rhodostichus* from other species in the region.

Description.—($n = 1$ male, 1 female; proportions are for the male, followed by those of the female). Head noticeably wider than body; HW 38.3, 38.7% SVL; HL 36.3, 39.6% SVL; snout long, acuminate in dorsal view, acutely rounded above and inclined posteroventrally in profile; E–N 76.0, 79.2% length of eye; nostrils slightly protuberant, directed laterally; canthus rostralis weakly angular, nearly straight; loreal region weakly concave sloping abruptly to lips; lips not flared; upper eyelid with indistinct tubercles posterolaterally; upper eyelid width 85.0, 66.7% IOD; cranial crests absent; supratympanic fold weak, barely obscuring upper edge of tympanic annulus; side of head slightly inclined ventrolaterally; tympanic annulus thin; tympanic membrane not pustular or thickened; tympanic annulus round; diameter of tympanic annulus 40.0, 41.7% length of eye; postrictal tubercles small, subconical, posteroventral to tympanic annulus; skin on head smooth. Choanae large, nearly round, not concealed by palatal shelf of maxillary arch; vomerine odontophores, low, oblique, posteromedian to choanae, oval in outline, each about size of choana, separated medially by distance greater than width of odontophore, bearing 1-0, 3-3 teeth; tongue longer than wide, its posterior border shallowly notched, posterior half not adherent to floor of mouth. Male with vocal slits extending posterolaterally from midlateral base of tongue; vocal sac single, median, subgular; nuptial pads absent.

Dorsum of head, body, and limbs smooth with scattered, small, subconical tubercles, more pronounced in female than in male; dorsolateral folds absent; flanks tuberculate, especially in female; cloacal sheath and enlarged tubercles in cloacal region absent; skin on throat weakly areolate, on belly coarsely areolate; discoidal fold evident posteriorly. Ulnar tubercles few, low, round; thenar tubercle ovoid, about $\frac{1}{2}$ size of weakly bifid palmar tubercle; supernumerary palmar tubercles few, minute; subarticular tubercles prominent, subconical; fingers bearing distinct lateral fringes; Finger I shorter than II; disc on thumb barely expanded; disc on Finger II slightly larger; discs on Fingers III–IV broadly rounded, nearly twice width of digits; all fingers having ventral pads defined by circumferential grooves. Upper surfaces of hind limbs smooth with scattered small tubercles; heel lacking tubercle; outer edge of tarsus bearing three or four subconical tubercles; inner edge of tarsus with two or three low tubercles; inner metatarsal tubercle flat, elliptical, about $4\times$ subconical outer metatarsal tubercle; supernumerary plantar tubercles low, diffuse; subarticular tubercles round, subconical; toes bearing narrow lateral fringes; webbing absent; discs on toes slightly

smaller than those on fingers; tip of Toe V extending to middle of distal subarticular tubercle on Toe IV; tip of Toe III not extending to that tubercle; when hind limbs flexed perpendicular to axis of body, heels broadly overlapping; shank 53.8, 54.3% SVL.

Coloration in preservative: Dorsum tan with sparse brown markings—KU 212264: small spots laterally in scapular and sacral regions, narrow interorbital bar, weakly defined labial bars and transverse bars on hind limbs; KU 212265: short lines laterally in scapular and sacral regions, narrow interorbital bar, diagonal marks on top of snout, weakly defined labial bars and transverse bars on hind limbs. Small dark spots on flanks; posterior surfaces of thighs tan; venter pale tan with minute dark brown flecks laterally on throat and belly.

Coloration in life: KU 212264: Dorsum green with red and tan marks; anterior and posterior surfaces of thighs pale green; heels and elbows tan (Fig. 10); vocal sac yellow; belly cream; ventral surfaces of limbs pale green; iris reddish brown.

Measurements of holotype: SVL 19.3, tibia length 10.4, foot length 9.0, head width 7.4, head length 7.0, IOD 2.0, upper eyelid width 1.7, E–N 1.9, eye 2.5, tympanum 1.0.

Distribution and habitat.—The species is known only from one locality at 1080 m on the road from Abra Pardo Miguel to Moyobamba on the east slope of the northern part of the Cordillera Central in northern Peru (Fig. 32). Two adults and two juveniles were in terrestrial bromeliads in lower humid montane forest by day.

Etymology.—The specific name is derived from the Greek *rhodon*—meaning red and the Greek *stichos* meaning line; the name is applied in reference to the red linear markings on the dorsum of the body.

Remarks.—Two juveniles (KU 212266–67) have SVLs of 15.8 and 16.9 mm, respectively. Both are colored like the female paratype, except that both have a middorsal, brown, triangular mark (apex anterior) just anterior to the level of the sacrum.

Eleutherodactylus rufiocularis new species

Holotype.—KU 212313, a subadult female, from the east slope of Abra Pardo de Miguel, 2180 m, Provincia Rioja, Departamento San Martín, Peru, obtained on 31 January 1988 by Michael E. Morrison.

Paratypes.—KU 212312, collected with the holotype.

Referred specimens.—USNM 525465, subadult female, USNM 525464, 525467–68, and 525473 from the upper Río Comainas, base of Cerro Machinaza, 1750 m, Provincia Condorcanqui, Departamento Amazonas, Peru; USNM 525474–75 from Alfonso Ugarte, 1138 m, upper Río Comainas, Provincia Condorcanqui, Departamento Amazonas, Peru.

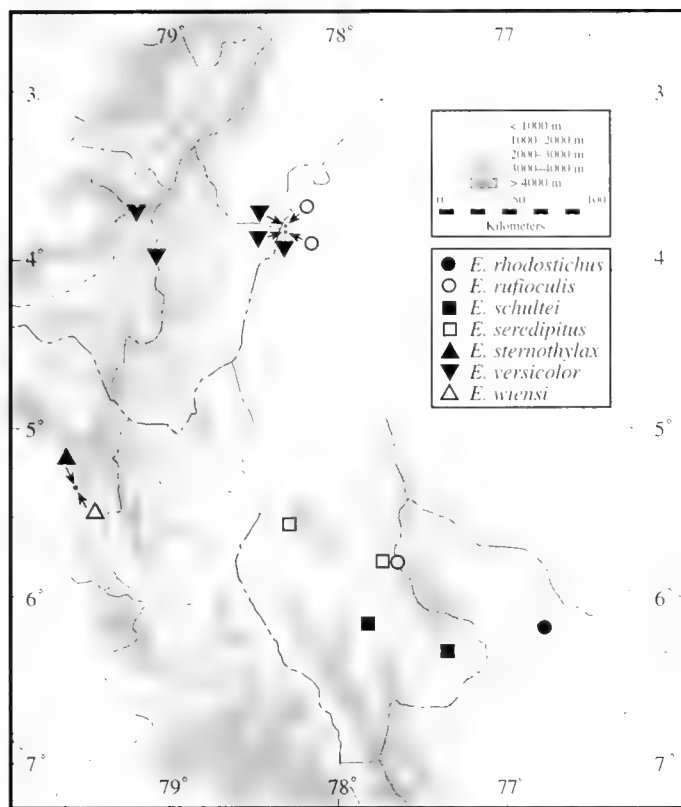

Fig. 32. Localities of known occurrence of seven species in the *Eleutherodactylus unistrigatus* group in the Andes of southern Ecuador and northern Peru.

Diagnosis.—A member of the *Eleutherodactylus unistrigatus* Group having (1) skin on dorsum smooth, that on venter areolate; discoidal fold present; dorsolateral folds absent; (2) tympanic membrane smooth, and tympanic annulus visible beneath skin, its length about 30% length of eye; (3) snout moderately long, rounded in dorsal view and in profile; (4) upper eyelid lacking tubercles, narrower than IOD; cranial crests absent; (5) vomerine odontophores elongately ovoid; (6) males lacking vocal slits and nuptial pads; (7) Finger I shorter than II; discs on outer fingers expanded, about twice width of digit proximal to pad; (8) fingers lacking lateral fringes; (9) ulnar tubercles absent; (10) heel and tarsus lacking tubercles; (11) inner metatarsal tubercle oval, 3× outer metatarsal tubercle; supernumerary plantar tubercles minute, diffuse; (12) toes bearing narrow lateral fringes; webbing absent; Toe V longer than III; discs slightly smaller than those on outer fingers; (13) dorsum tan; venter cream, suffused with brown; throat brown with cream flecks; groin brown with cream spots; posterior surfaces of thighs brown with cream flecks; (14) SVL in 1 male 18.1 mm, in 1 female 20.6 mm.

Eleutherodactylus rufiocularis is like *E. colodactylus* and *E. versicolor* in lacking vocal slits in males. Of these, *E.*

colodactylus differs by completely lacking a tympanic membrane and by having much shorter fingers with round discs, and *E. versicolor* differs by having a prominent tympanum, diagonal bars on the flanks, and dark reticulation on the belly. The flanks are dark brown with pale yellow or white spots in only two species in the region—*E. rufiocularis* and *E. muscosus*, which differs from *E. rufiocularis* by being larger and having tubercles on the upper eyelid and a conical tubercle on the heel. From the sympatric *E. nephophilus*, which also has a red iris, *E. rufiocularis* can be distinguished by having a smooth dorsum and no differentiated tympanum, and no tubercles on the eyelid, heel, or tarsus.

Description.—($n = 1$ male, 1 female; proportions are for the male, followed by those of the female). Head as wide as body; HW 36.5, 37.4% SVL; HL 39.8, 40.1% SVL; snout moderately long, rounded in dorsal view and in profile; E–N 135, 115% length of eye; nostrils barely protuberant, directed laterally; canthus rostralis rounded, straight; loreal region barely concave; lips rounded; upper eyelid smooth; upper eyelid width 77.7, 70.3% IOD in female; cranial crests absent; supratympanic fold weak, not obscuring upper edge of tympanum; tympanic membrane smooth; tympanic annulus distinctly visible beneath skin; length of tympanic annulus 35%, 26% length of eye; postriatal tubercles low, diffuse; side of head nearly vertical. Choanae ovoid, not obscured by palatal shelf of maxillary arch; vomerine odontophores posteromedial to choanae, elongately ovoid in outline, each more than twice size of choana, separated medially by distance about equal to width of odontophore, each bearing 2–4 teeth in single row; tongue more than twice as long as wide, its posterior border barely notched; posterior half not adherent to floor of mouth; vocal slits and vocal sac absent.

Dorsum smooth; dorsolateral folds absent; flanks smooth; cloacal sheath and enlarged tubercles in cloacal region absent; skin on throat and belly weakly areolate; discoidal fold weak, evident only posteriorly. Upper surfaces of arms smooth; ulnar tubercles absent; thenar tubercle low, oval, smaller than bifid palmar tubercle, supernumerary palmar tubercles minute, diffuse; subarticular tubercles round; fingers lacking lateral fringes; Finger I shorter than II; disc on thumb not enlarged; discs on Fingers III and IV twice width of digits, that on Finger II 1.5× width of digit; all fingers bearing ventral pads defined by circumferential grooves; nuptial pads absent in male. Upper surfaces of hind limbs smooth; tubercles on heel and tarsus absent; inner metatarsal tubercle flat, oval, 3–4× of outer metatarsal tubercle; supernumerary plantar tubercles minute, diffuse; subarticular tubercles round, non conical; toes bearing narrow lateral fringes; webbing absent; tip of Toe V extending to middle of distal subarticular tu-

bercle on Toe IV; tip of Toe III not extending to that tubercle; when hind limbs flexed perpendicular to axis of body, heels overlapping by about $\frac{1}{4}$ length of shank; shank 56.4, 55.8% SVL.

Coloration in preservative: Dorsum reddish brown with faint darker brown interorbital bar, and flecks laterally in scapular region; indistinct darker brown transverse bars on limbs; flanks pale brown with large cream spots posteriorly; anterior surfaces of thighs creamy tan with vertical brown marks; posterior surfaces of thighs brown with cream flecks; venter creamy tan, heavily suffused with brown flecks. Male with pale tan on snout anterior to interorbital bar and on elbows and on heels.

Coloration in life: Dorsum olive (with two pairs of dull red spots in female; grayish-white snout and tan elbows and heels in male) (Fig. 10); groin and anterior surfaces and thighs mottled yellow and dull red; venter yellow with brown mottling; iris red (WED field notes, 31 January 1988).

Measurements of holotype: SVL 20.6, tibia length 11.5, foot length 9.2, head width 7.7, head length 8.2, IOD 2.7, upper eyelid width 1.9, E-N 2.2, eye 2.6, tympanum 0.7.

Distribution and habitat.—The species is known from the type locality at 2180 m on the eastern slopes of the northern part of the Cordillera Central and from 1138 m and 1750 m on the eastern slopes of the Cordillera del Cóndor (Fig. 32). All individuals were on low vegetation (≤ 1 m) in humid montane forest at night.

Etymology.—The specific name is derived from the Latin *rufus*, meaning red, and the Latin *oculis*, meaning eye; the name is used in reference to the red iris.

Remarks.—The small series from the Cordillera del Cóndor consists of one subadult female having a SVL of 20.2 mm and six juveniles having SVLs of 13.4–17.3 (\bar{x} = 15.1) mm. The color patterns of these specimens are like that of the type series, except that two juveniles have dark W-shaped marks in the scapular region and transverse bars in the sacral region. Another juvenile has dark brown transverse marks in the scapular and sacral regions and a broad, pale bar immediately anterior to the interorbital bar.

Eleutherodactylus schultei Duellman

Eleutherodactylus schultei Duellman, 1990a:348. Holotype: KU 212222, adult male, from 5 km N Levanto, 2850 m, Departamento Amazonas, Peru.

Diagnosis.—A member of the *Eleutherodactylus* (*Eleutherodactylus*) *unistrigatus* Group having (1) skin on dorsum shagreen, bearing low, tubercles on forelimbs and in tympanic region, that on venter areolate; discoidal fold absent; dorsolateral folds absent; (2) tympanic membrane and tympanic annulus distinct, round, its length slightly less than $\frac{1}{2}$ length of eye; (3) snout subacuminate in dorsal view, inclined posteroventrally in profile; canthus rostralis rounded; (4) upper eyelid bearing low tubercles, narrower

than IOD; cranial crests absent; (5) vomerine odontophores present or absent, oblique; (6) males having vocal slits but lacking nuptial pads; (7) Finger I shorter than II; discs broad, rounded; (8) fingers bearing lateral fringes; (9) ulnar tubercles present, low; (10) heel and outer edge of tarsus bearing many, low tubercles; inner edge of tarsus lacking fold; (11) inner metatarsal tubercle ovoid, $2\times$ subconical outer metatarsal tubercle; plantar supernumerary tubercles numerous; (12) toes bearing lateral fringes; webbing absent; Toe V much longer than III; discs equal to those on fingers; (13) dorsum tan, reddish brown, or green, bordered or not by narrow dark brown line from snout to point above vent; venter white; (14) SVL in males 23.5–26.6 mm, in females 28.4–34.0 mm.

Eleutherodactylus schultei is one of three species in the region in which the snout is acuminate or subacuminate in dorsal view and inclined posteroventrally in profile (Fig. 10). Of these, *E. acuminatus*, which like *E. schultei*, lacks a pattern on the dorsum of the body, differs by lacking a tympanic annulus; *E. rhodostichus* has dark markings on the dorsum of the body and lacks a tubercle on the heel.

Description.—The description by Duellman (1990) is adequate.

Distribution and habitat.—This species is known from only two localities at elevations of 2400 and 2850 m in humid montane forest in the northern part of the Cordillera Central in Departamento Amazonas, Peru (Fig. 32). The second locality (5 km [by road] NW of Mendoza) is about 42 km [airline] east of the type locality. The frogs were found in large terrestrial and arboreal bromeliads by day.

Eleutherodactylus serendipitus new species

Holotype.—KU 181279, adult male, from 8 km [by road] NNE Balzapata, 1850 m, Provincia Bongará, Departamento Amazonas, Peru, obtained on 3 March 1979 by William E. Duellman.

Paratype.—KU 181280, an adult male, collected with the holotype.

Referred specimens.—LSUMZ 39360, subadult female, and LSUMZ 39363 and 39376, juveniles, from 12 km [by trail] E La Peca, 1700 m, western slope of the Cordillera Colán, Provincia Bagua, Departamento Amazonas, Peru.

Diagnosis.—A member of the *Eleutherodactylus* (*Eleutherodactylus*) *unistrigatus* Group having (1) skin on dorsum finely tuberculate, that on venter areolate; discoidal fold barely evident posteriorly; dorsolateral folds absent; (2) tympanic membrane smooth, and tympanic annulus distinct, its length about 40% length of eye; (3) snout moderately long, subacuminate in dorsal view and bluntly round in profile; (4) upper eyelid lacking tubercles, narrower than IOD; cranial crests absent; (5) vomerine

odontophores oblique; (6) males having vocal slits and nuptial pads; (7) Finger I shorter than II; discs on outer fingers expanded, nearly truncate, more than twice width of digit proximal to pad; (8) fingers lacking lateral fringes; (9) ulnar tubercles absent; (10) heel and outer edge of tarsus lacking tubercles; weak inner tarsal fold on distal third of tarsus (11) inner metatarsal tubercle elevated, elongately elliptical, about 8× outer subconical metatarsal tubercle; supernumerary plantar tubercles low, subconical; (12) toes lacking lateral fringes; webbing absent; Toe V much longer than III; discs slightly smaller than those on outer fingers; (13) dorsum tan with diffuse brown markings; venter cream with brown flecks; groin cream; posterior surfaces of thighs brown; (14) SVL in 2 males 20.4–21.2 (\bar{x} = 20.8).

Eleutherodactylus serendipitus has uniformly brown flanks and hidden surfaces of the thighs; three other species in the *Eleutherodactylus unistrigatus* group in the Andes of northern Peru are similarly colored. Of these, *E. ockendeni* and *E. pecki* differ by having tubercles on the upper eyelid and a tubercle on the heel. Furthermore, in the former the width of the upper eyelid equals the IOD, and in the latter the venter is densely flecked with brown. *Eleutherodactylus percnopterus* differs by having a more rounded snout in profile and diagonal (instead of transverse) bars on the hind limbs, and by lacking vomerine odontophores.

Description.—(n = 2 males). Head about as wide as body; HW 34.9–37.3 (\bar{x} = 36.1)% SVL; HL 37.7–38.7 (\bar{x} = 38.2)% SVL; snout moderately long, subacuminate in dorsal view, bluntly rounded in profile; E–N 76.0–78.6 (\bar{x} = 77.3)% length of eye; nostrils distinctly protuberant, directed dorsolaterally; canthus rostralis rounded, straight; loreal region barely concave; lips rounded; upper eyelid smooth; upper eyelid width 70.0–71.4 (\bar{x} = 70.7)% IOD; cranial crests absent; supratympanic fold weak, barely obscuring upper edge of tympanum; tympanic membrane smooth; tympanic annulus prominent; length of tympanic annulus 39.3–44.0 (\bar{x} = 41.7)% length of eye; postriatal tubercles low, diffuse; side of head nearly vertical. Choanae ovoid, not obscured by palatal shelf of maxillary arch; vomerine odontophores posteromedial to choanae, small, elliptical, separated medially by distance more than width of odontophore, each bearing two teeth in single row (absent in KU 181280); tongue nearly twice as long as wide, its posterior border not notched; posterior half not adherent to floor of mouth; vocal slits and median, subgular vocal sac absent.

Dorsum of snout smooth; other dorsal surfaces smooth with scattered, small tubercles, especially prominent on flanks; dorsolateral folds absent; cloacal sheath and enlarged tubercles in cloacal region absent; skin on throat and chest smooth, that on belly areolate; discoidal fold barely evident posteriorly. Upper surfaces of arms smooth

with scattered, minute tubercles; ulnar tubercles absent (indistinct ulnar fold in KU 181279); thenar tubercle ovoid, about same size as bifid palmar tubercle, supernumerary palmar tubercles minute; subarticular tubercles round; fingers lacking lateral fringes; first finger shorter than second; disc on thumb barely enlarged; discs on Fingers III and IV more than twice width of digits, that on Finger II 1.5× width of digit; all fingers bearing ventral pads defined by circumferential grooves; nuptial pads absent. Upper surfaces of hind limbs smooth; tubercles on heel and outer edge of tarsus absent; low, indistinct inner tarsal fold on distal end of tarsus; inner metatarsal tubercle elevated, elongately elliptical, 8× subconical outer metatarsal tubercle; supernumerary plantar tubercles distinct, in single row on proximal segments; subarticular tubercles round, nonconical; toes lacking lateral fringes; webbing absent; discs on toes slightly smaller than those on fingers; tip of Toe V extending to middle of distal subarticular tubercle on Toe IV; tip of Toe III extending to middle of penultimate subarticular tubercle on Toe IV; when hind limbs flexed perpendicular to axis of body, heels overlapping by about ¼ length of shank; shank 55.2–55.4 (55.3) % SVL.

Coloration in preservative: Dorsum tan with diffuse brown marks—broad interorbital bar, canthal stripe, single labial bar, supratympanic stripe, diagonal mark on either side in scapular region (Fig. 10); chevron (KU 181279) or transverse mark (KU 181280) in sacral region, flanks pale brown anteriorly, cream with minute brown flecks posteriorly; posterior surfaces of thigh pale brown; venter cream with brown flecks.

Coloration in life: At night, pale gray; by day, brown with darker brown markings; venter gray and throat dull yellow, both heavily flecked with gray; iris dull bronze with median, horizontal red-brown streak (WED field notes, 3 March 1979).

Measurements of holotype: SVL 20.4, tibia length 11.3, foot length 9.5, head width 7.6, head length 7.9, IOD 2.9, upper eyelid width 2.0; E–N 1.9, eye 2.5, tympanum 1.1.

Distribution and habitat.—The species is known from the type locality at 1850 m on the upper western slopes of the northern part of the Cordillera Central, which is drained by tributaries of the Río Chiriaco that flows northward into the Río Marañón, and from 1700 m of the western slopes of the Cordillera Colán (Fig. 32). At the type locality, two males were calling at night from leaves of low herbaceous plants in highly disturbed humid upper montane forest. In the Cordillera Colán, a subadult female was on a bush near a stream, and two juveniles were in leaf litter in humid montane forest.

Etymology.—The specific name is the Latinized English word seredipitous, meaning characterized by

seredipity, which comes from the Persian fairy tale, *The Three Princes of Serendip*, who were known for finding valuable things that were not sought for. The collection of amphibians made at the type locality was seredipitous because a stop was made there only after we were unable to proceed on a road closed by an accident.

Remarks.—Of the specimens from the Cordillera Colán, the subadult female has a SVL of 21.7 mm, and the juveniles have SVLs of 13.8 and 14.6 mm. The female (LSUMZ 39360) has narrow dorsolateral dark streaks posterior to the sacrum and a short, median interorbital mark.

The type locality of this species also is the type locality of *Hyla aperomea* Duellman, *Phyllomedusa duellmani* Cannatella, and *Scinax oreites* Duellman and Wiens.

Eleutherodactylus sternothylax Duellman and Wild

Eleutherodactylus sternothylax Duellman and Wild, 1993:17. Holotype: KU 219793, adult male, from 16 km [by road] ENE Canchaque, 1840 m, Provincia Huancabamba, Departamento Piura, Peru.

Diagnosis.—A member of the *Eleutherodactylus* (*Eleutherodactylus*) *unistrigatus* Group having (1) skin on dorsum shagreen, bearing few, low, round tubercles posteriorly and laterally, that on venter areolate; discoidal fold evident; dorsolateral folds absent; (2) tympanic membrane and tympanic annulus distinct, round, its length about ½ length of eye; (3) snout subacuminate in dorsal view, acutely rounded in profile; canthus rostralis acutely rounded; (4) upper eyelid bearing low, round tubercles, narrower than IOD; cranial crests absent; (5) vomerine odontophores prominent, oval; (6) males having vocal slits but lacking nuptial pads; (7) Finger I shorter than II; discs broad, truncate; (8) fingers bearing lateral fringes; (9) ulnar tubercles absent; (10) heel and tarsus lacking tubercles; inner edge of tarsus lacking fold; (11) inner metatarsal tubercle elliptical, 3–4× round outer metatarsal tubercle; plantar supernumerary tubercles diffuse; (12) toes bearing lateral fringes; webbing absent; Toe V much longer than III; discs smaller than those on fingers; (13) dorsum tan with dark brown markings; venter cream with minute brown flecks; (14) SVL in males 18.3–29.1 mm, in females 28.3–36.7 mm.

The presence of an acuminate snout and absence of tubercles on the upper eyelids and heels distinguishes *Eleutherodactylus sternothylax* from all other members of the *Eleutherodactylus unistrigatus* Group in the region, except *E. acuminatus* and *E. anemerus*. The former differs by lacking a tympanic membrane and dark markings on the dorsum and flanks, whereas the latter differs by having a prominent tubercle on the tip of the snout, as well as lacking dark markings.

Description.—The description by Duellman and Wild (1993) is adequate.

Distribution and habitat.—This species is known only from elevations of 1735–1840 m in humid montane forest on the western slopes of the Cordillera de Huancabamba (Fig. 32).

Eleutherodactylus versicolor Lynch

Eleutherodactylus versicolor Lynch, 1979:45. Holotype: KU 119858, adult male, from 13.5 km [by road] E Loja, 2800 m, Provincia Loja, Ecuador.

Diagnosis.—A member of the *Eleutherodactylus* (*Eleutherodactylus*) *unistrigatus* Group having (1) skin on dorsum shagreen with fine tubercles, that on venter areolate; discoidal fold prominent; dorsolateral folds absent; (2) tympanic membrane and tympanic annulus prominent, length of tympanum about 40–50% length of eye; (3) snout subacuminate in dorsal view, rounded in profile; canthus rostralis angular; (4) upper eyelid bearing tubercles or not, narrower than IOD; cranial crests absent; (5) vomerine odontophores prominent, oblique; (6) males lacking vocal slits and nuptial pads; (7) Finger I shorter than II; discs broad, elliptical; (8) fingers bearing weak lateral fringes or none; (9) ulnar tubercles low, diffuse; (10) heel lacking tubercles; outer edge of tarsus bearing row of small, conical tubercles; inner edge of tarsus bearing low fold distally; (11) inner metatarsal tubercle ovoid, 3–4× conical outer metatarsal tubercle; plantar supernumerary tubercles numerous, conical; (12) toes lacking lateral fringes; webbing absent; Toe V much longer than III; discs slightly smaller than those on fingers; (13) dorsum brown with darker brown markings—chevrons, interorbital bar, canthal and supratympanic stripes; flanks usually with vertical bars; venter cream with brown reticulations; (14) SVL in males 19.3–25.2 mm, in females 22.7–29.8 mm (Lynch, 1979).

The only other species in the region that can be confused with *Eleutherodactylus versicolor* is *E. ardalonychus*, which also has diagonal bars on the flanks and brown reticulations on the venter, but the reticulations are much finer than those in *E. versicolor*. Furthermore, *E. ardalonychus* differs by having a smooth dorsum, no tympanic membrane and tympanic annulus visible only ventrally, and rounded, instead of elliptical, discs on the outer fingers.

Description.—The description by Lynch (1979) requires slight modification. Specimens herein assigned to this species are like topotypic material except that tubercles are present on the upper eyelids—1/2 in one specimen, 2/3 in one, and many in four.

Distribution and habitat.—This species has been reported from an elevation of 3100 m in subparamo north of San Lucas, Provincia Loja, Ecuador and from 2500–2800 m in subparamo and cloud forest at Abra de Zamora, Ecuador (Lynch, 1979). The specimens reported herein are from somewhat lower elevations on the eastern slopes of the Cordillera del Cóndor and represent the first records

of the species from Peru (Fig. 32). The following localities are in humid montane forest in Departamento Amazonas: upper Río Comainas, base of Cerro Machinaza, 1750 m (USNM 525466, 525477), Alfonso Ugarte, upper Río Comainas, 1138 m (USNM 525469, 525471–72); Puesto Vigilancia Comainas, upper Río Comainas, 665 m (USNM 525441). All of the Peruvian specimens were collected at night on vegetation up to 2 m above the ground.

Remarks.—Three of the specimens from the Cordillera del Cóndor are females having SVLs of 26.0, 26.2, and 27.3 mm; two are males having SVLs of 21.8 and 24.7 mm, and one is a juvenile with a SVL of 17.5 mm. Five individuals have dark, irregular, chevron-shaped marks on the dorsum; one male (USNM 525477) has pale cream dorsolateral stripes extending from the posterior edge of the eyelid to a point above the insertion of the hind limbs.

Eleutherodactylus wiensi Duellman and Wild

Eleutherodactylus wiensi Duellman and Wild, 1993:22. Holotype: KU 219795, adult male, from 12.7 km [by road] ENE Canchaque, 1600 m, Provincia Huancabamba, Departamento Piura, Peru.

Diagnosis.—A member of the *Eleutherodactylus* (*Eleutherodactylus*) *unistrigatus* Group having (1) skin on dorsum smooth with scattered, small, conical tubercles, that on venter areolate; discoidal fold evident; dorsolateral folds weak; (2) tympanic membrane absent and tympanic annulus evident only ventrally, its length about 30% length of eye; (3) snout acutely rounded in dorsal view, rounded in profile; canthus rostralis rounded; (4) upper eyelid bearing tubercles on outer edge or not, narrower

than IOD; cranial crests absent; (5) vomerine odontophores prominent, oblique; (6) males having vocal slits but lacking nuptial pads; (7) Finger I shorter than II; discs broad, truncate; (8) fingers bearing lateral fringes; (9) ulnar tubercles few, diffuse; (10) heel bearing single, conical tubercle; outer edge of tarsus bearing few, low, round tubercles; inner edge of tarsus bearing low fold distally; (11) inner metatarsal tubercle ovoid, 4× subconical outer metatarsal tubercle; plantar supernumerary tubercles minute; (12) toes bearing lateral fringes; webbing basal; Toe V much longer than III; discs equal to or slightly smaller than those on fingers; (13) dorsum grayish tan with irregular brown markings; venter cream with brown spots or reticulations; (14) SVL in males 27.8–33.0 mm, in female 37.0 mm.

This is one of four species in the *Eleutherodactylus unistrigatus* Group in the region that lacks a tympanic membrane but has a tympanic annulus visible ventrally (Fig. 10). Of these, *E. acuminatus*, which lacks dorsal markings, and *E. ardalonychus*, which has dark reticulations on the belly, differ from *E. wiensi* by having a tubercle on the heel; *E. rhodoplichus* differs by lacking vomerine odontophores and having tubercles on the upper eyelid.

Description.—The description by Duellman and Wild (1993) is adequate.

Distribution and habitat.—This species is known from only two localities at elevations of 1600 and 1735 m in humid montane forest on the western slope of the Cordillera de Huancabamba, Departamento Piura, Peru (Fig. 32). Individuals were perched on low vegetation at night.

BIOGEOGRAPHY

Because of the complex topography and diverse environments in the Andes of northern Peru and southern Ecuador, together with the intervening Huancabamba Depression, this region has many endemics, and it is the northern or southern limits of distributions of many taxa, such as toads of the *Bufo spinulosus* and *veraguensis* groups (Duellman and Schulte, 1992) and lizards of the genus *Pholidobolus* (Montanucci, 1973; Reeder, 1996). Aside from frogs of the genus *Eleutherodactylus*, many species of other groups of anurans are known only from this region—centrolenids (Cadle and McDiarmid, 1990; Duellman and Schulte, 1993), *Gastrotheca* (Duellman, 1987; Duellman and Trueb, 1988; Trueb and Duellman, 1978), and leptodactylids of the genera *Ischnocnema* (Duellman, 1990b; Lynch, 1974a), *Phrynopus* (Cannatella, 1984; Lynch, 1975a), and *Phyllonastes* (Duellman (1991b; Lynch, 1976), as well as lizards of the genus *Stenocercus* (Cadle, 1991). The dry valleys even are barriers to the distributions of montane-forest birds (Parker et al., 1985).

The following discussion refers to patterns of distribution of *Eleutherodactylus* only in the Andes of northern

Peru and southern Ecuador, and in the intervening Huancabamba Depression. Most of the species of *Eleutherodactylus* in the region inhabit humid montane forests, and many are restricted to that habitat or extend upward into very humid montane forest (including subparamo and paramo), where species richness is lower (Table 4). With few exceptions, only members of the *Eleutherodactylus conspicillatus* Group occur in the dry habitats in the Huancabamba Depression, where they usually are found along streams. Species in this group are widespread geographically and altitudinally in western South America (Lynch and Duellman, 1997). Two members of this group (*E. karcharias* and *E. metabates*) are known only from dry environments below 1000 m, and *E. lymani* inhabits these same environments, as well as montane habitats. In the region of the Huancabamba Depression, three members of the group (*E. avicuporum*, *condor*, and *cuneirostris*) are known only from humid montane forest. Three other species in the group (*E. citriogaster*, *lanthanites*, and *peruvianus*) primarily occupy humid tropical forest in the Amazon Basin, but ascend to humid montane forest

Table 4. Geographic and latitudinal distribution of *Eleutherodactylus* in the Andes of northern Peru and southern Ecuador. Numbers in columns are elevations in meters. Species followed by an asterisk (*) also occur in the upper Amazon Basin.

Species	Cordillera Occidental, Ecuador	Cordillera Oriental, Ecuador	Cordillera de Cutucú	Cordillera del Cóndor	Cordillera de Colán	Cordillera Central, Peru	Cordillera Occidental, Peru	Cordillera de Huan-cabamba
<i>Eleutherodactylus conspicillatus</i> Group								
<i>E. avicuporum</i>	—	—	—	—	1700–2030	—	—	—
<i>E. citriogaster</i>	—	—	—	—	—	600–800	—	—
<i>E. condor</i>	—	—	1975	1500–1750	—	—	—	—
<i>E. cuneirostris</i>	—	—	—	—	1700	—	—	—
<i>E. karcharias</i>	—	—	—	—	—	1000	—	—
<i>E. lanthanites*</i>	—	1000–1490	—	—	—	1630	—	—
<i>E. lymani</i> ¹	610–3000	—	—	—	—	—	—	1120–1850
<i>E. metabates</i> ²	—	—	—	—	—	—	—	—
<i>E. peruvianus*</i>	—	1410–1910	1700–1975	665–1750	—	—	—	—
<i>E. w-nigrum</i>	800–3200	1100–2220	—	—	—	—	—	—
<i>Eleutherodactylus nigrovittatus</i> Group								
<i>E. araiodactylus</i>	—	—	—	—	—	3370	—	—
<i>Eleutherodactylus orestes</i> Group								
<i>E. atrabracus</i>	—	—	—	—	2960–3330	—	—	—
<i>E. melanogaster</i>	—	—	—	—	—	3300–3470	—	—
<i>E. orestes</i>	—	2720–3120	—	—	—	—	—	—
<i>E. patakos</i>	—	—	—	—	—	3470	—	—
<i>E. pinguis</i>	—	—	—	—	—	—	3050–3760	—
<i>E. vidua</i>	—	2710–3100	—	—	—	—	—	—
<i>Eleutherodactylus unistriatus</i> Group								
<i>E. acuminatus*</i>	—	—	—	830	—	950	—	—
<i>E. altamazonicus*</i>	—	—	—	1500–1600	—	—	—	—
<i>E. anemerus</i>	—	—	—	—	—	—	—	2770
<i>E. ardalonychus</i>	—	—	—	—	—	680–1200	—	—
<i>E. atratus</i>	—	2195–2850	—	—	—	—	—	—
<i>E. balionotus</i>	—	2800	—	—	—	—	—	—
<i>E. baryecuuus</i>	—	2195–1990	—	—	—	—	—	—
<i>E. bearsei</i>	—	—	—	—	—	500–730	—	—
<i>E. bromeliaceus</i>	—	1710–2620	1700	1500–1600	—	2180	—	—
<i>E. cajamarcensis</i>	2660–3000	—	—	—	—	—	2200	3050–3100
<i>E. ceuthospilus</i>	—	—	—	—	—	—	1500	1735–2870
<i>E. colodactylus</i>	—	2195–3140	—	—	—	—	—	2745–3110
<i>E. cryophilus</i>	3080–3200	2835–3355	—	—	—	—	—	—
<i>E. cryptomelas</i>	—	2470–3100	—	—	—	—	—	2770–2820
<i>E. exoristus</i>	—	—	—	665–1550	—	—	—	—
<i>E. galdi</i>	—	1000–1740	1700–1975	1500–1550	1700	—	—	—
<i>E. ganonotus</i>	—	—	1700	—	—	—	—	—
<i>E. incomptus</i>	—	1270–1910	—	1300	—	—	—	—
<i>E. infraguttatus</i>	—	—	—	—	—	2000–2180	—	—
<i>E. lirellus</i>	—	—	—	—	—	470–1200	—	—
<i>E. muscosus</i>	—	—	—	—	—	1800	—	—
<i>E. nephophilus</i>	—	—	—	—	—	1080–2180	—	—
<i>E. nigrogriseus</i>	—	1180–2835	1700	1150	—	—	—	—
<i>E. ockendeni</i> ^{3,4}	—	1000–1100	—	900	—	—	—	—
<i>E. pecki</i>	—	—	1700	1138–1550	—	—	—	—
<i>E. percnopterus</i>	—	—	—	1138–1750	—	1830	—	—
<i>E. percultus</i>	—	2850	—	—	—	—	—	—
<i>E. percnopterus</i>	—	—	—	1138–1750	—	1830	—	—
<i>E. petrobarbus</i>	—	—	—	—	—	—	2500	—
<i>E. phoxocephalus</i>	1800–3100	—	—	—	—	—	1800	1850–2770
<i>E. prolatus</i>	—	1140–1490	1700	—	—	—	—	—
<i>E. proserpens</i>	—	1710–2620	1700	1550	—	—	—	—
<i>E. pycnodermis</i>	—	2650–3000	—	—	—	—	—	—
<i>E. quaquaversus</i>	—	920–1740	1700	1500–1550	—	—	—	—
<i>E. rhodoplichus</i>	—	—	—	—	—	—	—	2770–3050
<i>E. rhodostichus</i>	—	—	—	—	—	1080	—	—

Table 4 continued

Species	Cordillera Occidental, Ecuador	Cordillera Oriental, Ecuador	Cordillera de Cutucú	Cordillera del Cóndor	Cordillera de Colán	Cordillera Central, Peru	Cordillera Occidental, Peru	Cordillera de Huancabamba
<i>E. riveti</i>	2620–3420	2720–3280	—	—	—	—	—	—
<i>E. ruidus</i>	2317	—	—	—	—	—	—	—
<i>E. rufioculis</i>	—	—	—	1138–1750	—	2180	—	—
<i>E. schultei</i>	—	—	—	—	—	2400–2850	—	—
<i>E. serendipitus</i>	—	—	—	—	1700	1850	—	—
<i>E. spinosus</i>	—	1700–2835	—	1550	—	—	—	—
<i>E. sternothylax</i>	—	—	—	—	—	—	—	1735–1840
<i>E. trachyblepharis</i>	—	950–1250	—	900–1600	—	—	—	—
<i>E. ventrimarmoratus</i> ¹	—	1000–1740	1700	—	—	—	—	—
<i>E. versicolor</i>	—	2500–3100	—	665–1750	—	—	—	—
<i>E. wiensi</i>	—	—	—	—	—	—	—	1600–1735

¹Also at elevations of 500–1000 m in the Río Marañón Valley

²Only at elevation of 525 m in the Río Marañón Valley

³Also at elevation of 725 m in the Río Marañón Valley

on the eastern slopes of the Andes. Most species in this group are terrestrial and capable of lengthy leaps, as evidenced by their long hind limbs.

The *Eleutherodactylus nigrovittatus* Group consists of five species, one of which (*E. nigrovittatus*) has a broad distribution in the upper Amazon Basin in Ecuador and northern Peru. The other four species inhabit montane forests and subparamo in the Andes of Colombia, Ecuador, and northern Peru. Species in this group are small, terrestrial frogs that hop about in leaf litter. According to Lynch et al. (1997), the lowland *E. nigrovittatus* is the sister group to *E. latens* + *E. manipus* in the Colombian Andes, and these three species are the sister group to *E. elassodiscus* in the Ecuadorian Andes; they postulated dispersal of *E. nigrovittatus* as a means of explaining the geographical and cladistic relationships.

The seven species making up the *Eleutherodactylus orestes* Group are small, terrestrial frogs that make short hops; this mode of locomotion is correlated with the short hind limbs. Members of this group primarily have allopatric distributions in humid or very humid montane forests or subparamo and paramo. The distributions of *E. orestes* and *E. vidua* are mostly allopatric, but the two species occur sympatrically in the southern part of their ranges; *E. melanogaster* and *E. pataikos* occur sympatrically in the Cordillera Central in Peru.

Members of the large *Eleutherodactylus unistrigatus* Group reach their greatest diversification in humid montane forests, but many species occur in humid tropical forests, and a few extend upward above treeline. Although some species are encountered on the ground by day, these inhabitants of forests generally are arboreal, or at least perch on leaves and limbs of bushes at night. Only a few clades have been identified within this large group. Of the

species known from northern Ecuador, only *E. galdi* has been placed in a clade (Lynch, 1996; Lynch and Rueda-Almonacid, 1997); the four species in this clade have allopatric distributions in the Andes from northern Colombia to northern Peru.

Because phylogenetic relationships have not been ascertained among the *Eleutherodactylus* in the Andes of northern Peru and their extralimital congeners, only a descriptive analysis of their distributions is possible. Even this is hampered by the absence of collections from many areas. Nonetheless, some patterns seem to be apparent. More species (26) inhabit the southern part of the Cordillera Oriental in Ecuador than any other mountain system under consideration here⁴; this is followed by the Cordillera del Cóndor (19) and the northern part of the Cordillera Central in Peru (16). An intermediate number (11) is known from the Cordillera de Cutucú and Cordillera de Huancabamba, whereas many fewer species are known from the southern part of the Cordillera Occidental in Ecuador (7) and the Cordillera Occidental in Peru (5). These low numbers are indicative of the scarcity of suitable habitat for most species of *Eleutherodactylus*. The relatively low number of species recorded from the Cordillera de Cutucú and Cordillera Colán probably reflect the fact that no herpetologists have collected in those cordilleras; in fact, our existing knowledge of the anuran faunas in those cordilleras comes from collections made by ornithologists.

Endemism in the various cordilleras varies from 0% in the Cordillera del Cóndor to 75% in the Cordillera Central in northern Peru (Table 5). Endemism is highest in species that are distributed at elevations above 2000 m.

⁴Seventy-two species are known from the Cordillera Occidental in Colombia (J. D. Lynch, pers. comm.).

Table 5. Numerical comparisons of *Eleutherodactylus* in the Andes of southern Ecuador and northern Peru.

Region	Number Species	Number Endemic	Percent Endemic
Cordillera Occidental, Ecuador	7	1	14
Cordillera Oriental, Ecuador	26	7	27
Cordillera de Cutucú	11	1	9
Cordillera del Cóndor	19	0	0
Cordillera Colán	5	3	60
Cordillera Central, Peru	16	12	75
Cordillera Occidental, Peru	5	2	40
Cordillera de Huancabamba	11	4	36

The apparent absence of endemism in the Cordillera del Cóndor probably is related to the absence of collections from high elevations in that cordillera. On the other hand, the apparent high endemism in the Cordillera Central in Peru is owing to several species that are known only from the eastern slopes of that cordillera; once the Cordillera Colán becomes better known, it is assumed that several species now known in the Cordillera Central will show up in the Cordillera Colán.

Each of the eight cordilleras shares species with at least two other cordilleras (Fig. 33). Generally, the degree of commonality of species is related to distance, as well as elevations of intermediate regions. The two cordilleras just east of the Cordillera Oriental in Ecuador, the Cordillera de Cutucú and Cordillera del Cóndor share more species than do any other cordilleras. However, some of these species, as well as those shared with the Cordillera Central in Peru (e.g., *Eleutherodactylus acuminatus*, *lanthanites peruvianus*, and *ventrimarmoratus*), are primarily lowland species that ascend the slopes of the Andes. However, four species (*E. bromeliaceus*, *galdi*, *nigrogriseus*, and *proserpens*) that are shared by the Cordillera Oriental in Ecuador, Cordillera de Cutucú, and Cordillera del Cóndor are not known to occur at elevations of less than 1000 m.

Occupation of more than one cordillera is less common in the west, where drier environments occur at the lower elevations. However, *Eleutherodactylus cajamarcensis* occurs in three cordilleras and is unknown at elevations of less than 2200 m. Assuming that each species has changed little, if any, physiologically and ecologically during its existence, interpretation of present patterns of distribution

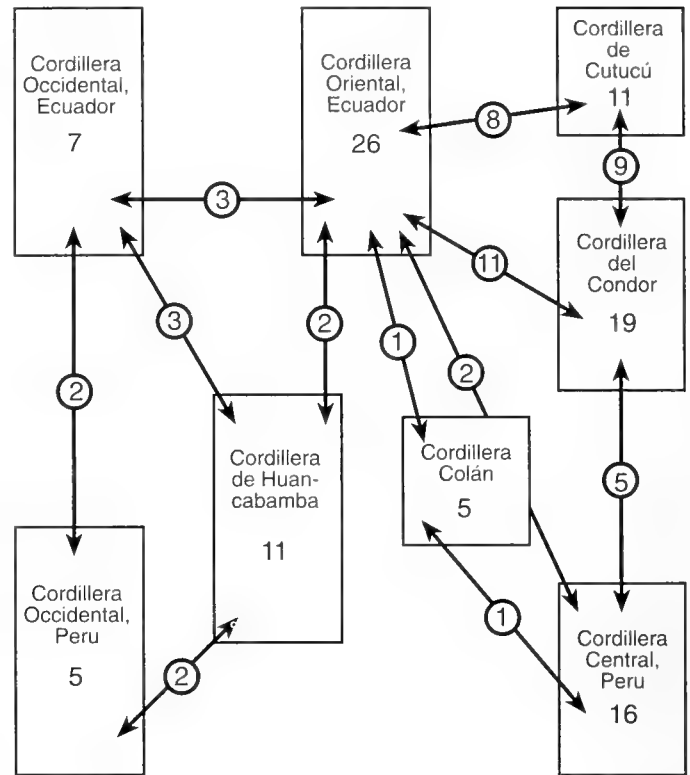

Fig. 33. Diagrammatic representation of eight cordilleras in southern Ecuador and northern Peru. Numbers in boxes are the number of species of *Eleutherodactylus* in each cordillera; numbers in circles indicate number of species shared by cordilleras at the ends of arrows.

must invoke past climatic change to account for present disjunctions. If the predictions of Pleistocene climatic depression in the Andes by Dollfus (1976), Hastenrath (1967), and Sauer (1971) are anywhere near correct, regions of humid montane forest now isolated on the various cordilleras would have been connected, thereby permitting dispersal among the cordilleras; subsequent elevation (in interglacial phases) would have resulted in isolation of populations and possibly speciation. This climatic-speciation model championed by Simpson (1979) was refined in theory by Lynch and Duellman (1997) for *Eleutherodactylus* in western Ecuador. Cladograms of various lineages of *Eleutherodactylus* in the Andes of Colombia follow this pattern of allopatric speciation within the same elevational limits (Lynch et al., 1997).

LITERATURE CITED

- Almendáriz, A. 1997. Amphibian and reptile species recorded in the northern and western Cordillera del Cóndor. Pp. 199–201 in T. S. Schulenberg and K. Awbrey (eds.), *The Cordillera del Cóndor Region of Ecuador and Peru: a biological assessment*. RAP Working Papers No. 7. Washington, D. C.: Conservation International.
- Andersson, L. G. 1945. Batrachians from east Ecuador collected 1937. 1938 by Wm. Clarke-Macintyre and Rolf Blomberg. *Arkiv för Zoologi*, 37A (2):1–88.
- Aubodin, J., A. V. Borrello, G. Cecioni, R. Charrier, P. Chotin, J. Frutos, R. Thiele, and J.-C. Vicente. 1973. Esquisse paléogéographique et structurale des Andes Méridionales. *Revue de Géographie Physique et de Géologie Dynamique* 15:11–72.
- Bokermann, W. C. A. 1958. A preoccupied name of a neotropical frog, genus *Eleutherodactylus*. *Herpetologica* 14:95.
- Boulenger, G. A. 1908. Descriptions of new batrachians and reptiles discovered by Mr. M. G. Palmer in south-western Colombia. *Annals &*

- Magazine of Natural History, Ser. 8, 12:515–522.
- Boulenger, G. A. 1912. Descriptions of new batrachians from the Andes of South America, preserved in the British Museum. *Annals & Magazine of Natural History*, Ser. 8, 10:185–191.
- Barbour, T., and G. K. Noble. 1920. Some amphibians from northwestern Peru, with a revision of the genera *Phyllobates* and *Telmatobius*. *Bulletin, Museum of Comparative Zoology, Harvard University* 63:395–427.
- Cadle, J. E. 1991. Systematics of lizards of the genus *Stenocercus* (Iguania: Tropicoduridae) from northern Peru: new species and comments on relationships and distribution patterns. *Proceedings Academy of Natural Sciences, Philadelphia* 143:1–96.
- Cadle, J. E., and R. W. McDiarmid. 1990. Two new species of *Centrolenella* (Anura: Centrolenidae) from northwestern Peru. *Proceedings Biological Society of Washington* 103:746–768.
- Cañadas, C. L. 1983. *El Mapa Bioclimático y Ecológico del Ecuador*. Quito: Editoriales Asociados Cia., Ltda.
- Cannatella, D. C. 1984. Two new species of the leptodactylid frog genus *Phrynonopus*, with comments on the phylogeny of the genus. *Occasional Papers, Museum of Natural History, University of Kansas* 113:1–16.
- Clapperton, C. M. 1987. Maximal extent of the late Wisconsin glaciation in the Ecuadorian Andes. Pp. 165–180 in J. Rabassa (ed.), *Quaternary of South America and Antarctic Peninsula*. Vol. 5. Rotterdam: A. A. Balkema.
- Colinvaux, P. A. 1993. Pleistocene biogeography and diversity in tropical forests of South America. Pp. 473–499 in P. Goldblatt (ed.), *Biological Relationships between Africa and South America*. New Haven: Yale University Press.
- Colinvaux, P. A., K. Olson, and K-b Liu. 1988. Late-glacial and Holocene pollen diagrams from two endorheic lakes of the inter-Andean plateau of Ecuador. *Review of Paleobotany and Palynology* 55:73–81.
- Cope, E. D. 1875. On the Batrachia and Reptilia of Costa Rica. *Journal of the Academy of Natural Sciences of Philadelphia*. New ser. 8(2):93–154.
- Dollfus, O. 1976. Les changements climatique Holocenes dans les hautes Andes tropicales. *Bulletin de l'Association Geographique Française* 433:95–103.
- Duellman, W. E. 1978a. Two new species of *Eleutherodactylus* (Anura: Leptodactylidae) from the Peruvian Andes. *Transactions of the Kansas Academy of Science* 81:65–71.
- Duellman, W. E. 1978b. New species of leptodactylid frogs of the genus *Eleutherodactylus* from the Cosñipata Valley, Peru. *Proceedings of the Biological Society of Washington* 91:418–430.
- Duellman, W. E. 1978c. The biology of an equatorial herpetofauna in Amazonian Ecuador. *Miscellaneous Publication, Museum of Natural History, University of Kansas* 65:1–352.
- Duellman, W. E. 1987. Two new species of marsupial frogs (Anura: Hylidae) from Peru. *Copeia* 1987:903–909.
- Duellman, W. E. 1990a. A new species of *Eleutherodactylus* from the Andes of northern Peru (Anura: Leptodactylidae). *Journal of Herpetology* 24:348–350.
- Duellman, W. E. 1990b. A new species of leptodactylid frog, genus *Ischnocnema*, from Peru. *Occasional Papers, Museum of Natural History, University of Kansas* 138:1–7.
- Duellman, W. E. 1991a. A new species of *Eleutherodactylus* (Anura: Leptodactylidae) from the Cordillera Occidental of Peru. *Herpetologica* 47:6–9.
- Duellman, W. E. 1991b. A new species of leptodactylid frog, genus *Phyllonastes*, from Peru. *Herpetologica* 47:9–13.
- Duellman, W. E. 1992a. *Eleutherodactylus bearsei* new species (Anura: Leptodactylidae) from northeastern Peru. *Occasional Papers, Museum of Natural History, University of Kansas* 150:1–7.
- Duellman, W. E. 1992b. A new species of the *Eleutherodactylus conspicillatus* group (Anura: Leptodactylidae) from northeastern Peru. *Revista Española de Herpetología* 6:23–29.
- Duellman, W. E., and J. D. Lynch. 1988. Anuran amphibians from the Cordillera de Cutucú, Ecuador. *Proceedings of the Academy of Natural Science of Philadelphia* 140:125–142.
- Duellman, W. E., and J. R. Mendelson III. 1995. Amphibians and reptiles from northern Departamento Loreto, Peru: taxonomy and biogeography. *University of Kansas Science Bulletin* 55:329–376.
- Duellman, W. E., and R. Schulte. 1992. Description of a new species of *Bufo* from northern Peru with comments on phenetic groups of South American toads (Anura: Bufonidae). *Copeia* 1992:162–172.
- Duellman, W. E., and R. Schulte. 1993. New species of centrolenid frogs from northern Peru. *Occasional Papers, Museum of Natural History, University of Kansas* 155:1–33.
- Duellman, W. E., and C. A. Toft. 1979. Anurans from Serranía de Sira, Amazonian Perú: taxonomy and biogeography. *Herpetologica* 35:60–70.
- Duellman, W. E., and L. Trueb. 1988. Cryptic species of hylid marsupial frogs in Peru. *Journal of Herpetology* 22:159–179.
- Duellman, W. E., and E. R. Wild. 1993. Anuran amphibians from the Cordillera de Huancabamba, northern Peru: systematics, ecology, and biogeography. *Occasional Papers, Museum of Natural History, University of Kansas* 157:1–53.
- Dwyer, C. M. 1995. A new species of *Eleutherodactylus* from Peru (Anura: Leptodactylidae). *Amphibia-Reptilia* 16:245–256.
- Enock, C. R. 1907. *The Andes and the Amazon*. New York: Charles Scribner's Sons.
- Flores, G., and L. O. Rodríguez. 1997. Two new species of the *Eleutherodactylus conspicillatus* group (Anura: Leptodactylidae) from Perú. *Copeia* 1997:388–394.
- Flores, G., and G. O. Vigle. 1994. A new species of *Eleutherodactylus* (Anura: Leptodactylidae) from the lowland rainforests of Amazonian Ecuador, with notes on the *Eleutherodactylus frater* assembly. *Journal of Herpetology*, 28:416–424.
- Foster, R. B., and H. Beltran. 1997. Vegetation and flora of the eastern slopes of the Cordillera del Cóndor. Pp. 44–63 in T. S. Schulenberg and K. Awbrey (eds.), *The Cordillera del Cóndor Region of Ecuador and Peru: a biological assessment*. RAP Working Papers No. 7. Washington, D. C.: Conservation International.
- Gansser, A. 1973. Facts and theories on the Andes. *Journal of the Geological Society, London* 129:93–131.
- Gorham, S. W. 1966. Liste der rezenten Amphibien und Reptilien: Ascaphidae, Leiopelmatidae, Pipidae, Discoglossidae, Pelobatidae, Leptodactylidae, Rhinophrynidae. *Das Tierreich* 85:i–xvi, 1–222.
- Ham, C. K., and L. J. Herrera, Jr. 1963. Role of sub-Andean fault system in tectonics of eastern Peru and Ecuador. Pp. 47–61 in O. E. Childs and B. W. Beebe (eds.), *Backbone of the Americas*. Memoir, American Association of Petroleum Geologists.
- Harrington, H. J. 1956. Main morphostructural regions of South America. Pp. xii–xviii in W. F. Jenks (ed.), *Handbook of South American Geology*. Memoir, Geological Society of America.
- Harrington, H. J. 1962. Paleogeographic development of South America. *Bulletin of the American Association of Petroleum Geologists* 46:1773–1814.
- Harvey, M. B., and M. B. Keck. 1995. A new species of *Ischnocnema* (Anura: Leptodactylidae) from high elevations in the Andes of Central Bolivia. *Herpetologica* 51:56–66.
- Hastenrath, S. I. 1967. Observations on the snow line in the Peruvian Andes. *Journal of Glaciology* 6:541–550.
- Herd, D. G., and C. W. Naeser. 1974. Radiometric evidence for pre-Wisconsinian glaciation in the northern Andes. *Geology* 2:603–604.
- Holdridge, L. R. 1967. *Life Zone Ecology*. San José, Costa Rica: Tropical Science Center.
- Hoogmoed, M. S., J. D. Lynch, and J. Lescure. 1977. A new species of *Eleutherodactylus* from Guiana (Leptodactylidae, Anura). *Zoologische Mededelingen, Rijksmuseum van Natuurlijke Historie Leiden* 51: 33–41.
- James, D. E. 1973. The evolution of the Andes. *Scientific American* 229(2):60–70.

- Jiménez de la Espada, D. M. X. 1870. Faunae neotropicalis species quaedam nondum cognitae. *Jornal de Sciencias Mathematicas Physicas e Naturaes, Academia Real das Sciencias de Lisboa* 3 (9):57–65
- Lynch, J. D. 1968. Systematic status of some Andean leptodactylid frogs with a description of a new species of *Eleutherodactylus*. *Herpetologica* 24:289–300.
- Lynch, J. D. 1969. Taxonomic notes on Ecuadorian frogs (Leptodactylidae: *Eleutherodactylus*). *Herpetologica* 25:262–274.
- Lynch, J. D. 1971. Evolutionary relationships, osteology, and zoogeography of leptodactylid frogs. *Miscellaneous Publication, Museum of Natural History, University of Kansas* 53:1–238.
- Lynch, J. D. 1974a. A new species of leptodactylid frog (*Ischnocnema*) from the Cordillera del Condor, Ecuador. *Journal of Herpetology*, 8:85–87.
- Lynch, J. D. 1974b. New species of frogs (Leptodactylidae: *Eleutherodactylus*) from the Amazonian lowlands of Ecuador. *Occasional Papers, Museum of Natural History, University of Kansas* 31:1–22.
- Lynch, J. D. 1975a. A review of the Andean leptodactylid frog genus *Phrynosus*. *Occasional Papers, Museum of Natural History, University of Kansas* 35:1–51.
- Lynch, J. D. 1975b. The identity of the frog *Eleutherodactylus conspicillatus* (Günther), with descriptions of two related species from northwestern South America (Amphibia, Leptodactylidae). *Contributions in Science, Natural History Museum of Los Angeles County* 272:1–19.
- Lynch, J. D. 1976. Two new species of frogs of the genus *Euparkerella* (Amphibia: Leptodactylidae) from Ecuador and Peru. *Herpetologica* 32:48–53.
- Lynch, J. D. 1979. Leptodactylid frogs of the genus *Eleutherodactylus* from the Andes of southern Ecuador. *Miscellaneous Publication, Museum of Natural History, University of Kansas* 66:1–62.
- Lynch, J. D. 1980. A taxonomic and distributional synopsis of the Amazonian frogs of the genus *Eleutherodactylus*. *American Museum Novitates* 2696:1–24.
- Lynch, J. D. 1986. New species of minute leptodactylid frogs from the Andes of Ecuador and Peru. *Journal of Herpetology* 20:423–431.
- Lynch, J. D. 1989. Intrageneric relationships of mainland *Eleutherodactylus* (Leptodactylidae). I. A review of the frogs assigned to the *Eleutherodactylus discoidalis* species group. *Contributions in Biology and Geology, Milwaukee Public Museum* 79:1–25.
- Lynch, J. D. 1996. New frog (*Eleutherodactylus*: Leptodactylidae) from the Andes of eastern Colombia, part of a remarkable pattern of distribution. *Copeia* 1996:103–108.
- Lynch, J. D., and W. E. Duellman. 1980. The *Eleutherodactylus* of the Amazonian slopes of the Ecuadorian Andes (Anura: Leptodactylidae). *Miscellaneous Publication, Museum of Natural History, University of Kansas* 69:1–86.
- Lynch, J. D., and W. E. Duellman. 1997. Frogs of the genus *Eleutherodactylus* in western Ecuador: systematics, ecology, and biogeography. *Special Publication, Natural History Museum, University of Kansas* 23:1–236.
- Lynch, J. D., and M. S. Hoogmoed. 1977. Two new species of *Eleutherodactylus* (Amphibia: Leptodactylidae) from northeastern South America. *Proceedings of the Biological Society of Washington* 90:424–439.
- Lynch, J. D., P. M. Ruiz-Carranza, and M. C. Ardila-Robayo. 1997. Biogeographic patterns of Colombian frogs and toads. *Revista de la Academia Colombiana de Ciencias Exactas, Físicas y Naturales* 21:237–248.
- Lynch, J. D., and J. V. Rueda-Almonacid. 1997. Three new frogs (*Eleutherodactylus*: Leptodactylidae) from cloud forests in eastern Departamento Caldas, Colombia. *Revista de la Academia Colombiana de Ciencias Exactas, Físicas y Naturales* 21:131–142
- Melin, D. 1941. Contribution to a knowledge of the Amphibia of South America. *Göteborgs Kungl. Vetenskaps- och Vitterhets-Samhälles Handlingar Series 6 B*, 1(4):1–70.
- Montanucci, R. R. 1973. Systematics and evolution of the Andean lizard genus *Pholidobolus* (Sauria: Teiidae). *Miscellaneous Publication, Museum of Natural History, University of Kansas* 59:1–52.
- Noble, D. C., E. H. McKee, T. Mourier, and F. Mégard. 1990. Cenozoic stratigraphy magmatic activity, compressive deformation, and uplift in northern Peru. *Geological Society of America Bulletin* 102:1105–1113.
- Noble, G. K. 1921. A search for the marsupial frog. *Natural History* 21:474–485.
- Parker, H. W. 1932. Some new or rare reptiles and amphibians from southern Ecuador. *Annals and Magazine of Natural History* (10)14:21–26.
- Parker, T. A., III, T. S. Schulenberg, G. R. Graves, and M. J. Braun. 1985. The avifauna of the Huancabamba reguion, northern Peru. *Ornithology Monographs* 36:169–197.
- Peracca, M. G. 1904. Viaggio del Dr. Enrico Festa nell' Ecuador e regioni vicine. Rettili ed anfibiai. *Bollettino el Muso di Zoologia dell' Università di Torino*, 19 (465):1–41.
- Peters, J. A. 1955. Herpetological type localities in Ecuador. *Revista Ecuatoriana de Entomologia-Parasitologia* 2:335–352.
- Reeder, T. W. 1996. A new species of *Pholidobolus* (Squamata: Gymnophthalmidae) from the Huancabamba Depression of northern Peru. *Herpetologica*, 52:282–289.
- Reynolds, R. P., and J. Icochea M. 1997. Amphibian and reptile species of the upper Río Comainas, Cordillera del Cóndor. Pp. 82–84, 204–206 in T. S. Schulenberg and K. Awbrey (eds.), *The Cordillera del Cóndor Region of Ecuador and Peru: a biological assessment*. RAP Working Papers No. 7. Washington, D. C.: Conservation International.
- Rodríguez, L. O. 1994. A new species of the *Eleutherodactylus conspicillatus* group (Leptodactylidae) from Peru, with comments on its call. *Alytes* 12:49–63.
- Sauer, W. 1971. *Geologie von Ecuador*. Berlin: Gebrüder Borntraeger.
- Savage, J. M. 1975. Systematics and distribution of the Mexican and Central American stream frogs related to *Eleutherodactylus rugulosus*. *Copeia* 1975:254–306.
- Schwerdtfeger, W. (ed.). 1976. *World Survey of Climatology. Vol. 12. Climates of Central and South America*. Amsterdam: Elsevier.
- Sempere, T., G. Hérail, J. Oller, and M. G. Bonhomme. 1990. Late Oligocene-Early Miocene major tectonic crisis and related basins in Bolivia. *Geology* 18:946–949.
- Shagam, R. 1975. The northern termination of the Andes. Pp. 325–420 in A. E. M. Nairn and F. G. Stehli (eds.), *The Ocean Basins and Margins. Vol. 3. The Gulf of Mexico and the Caribbean*. New York: Plenum Press.
- Shreve, B. 1935. On a new teiid and Amphibia from Panama, Ecuador, and Paraguay. *Occasional Papers of the Boston Society of Natural History* 8:209–218.
- Sillitoe, R. H. 1974. Tectonic segmentation of the Andes: implications for magnetism and metalogeny. *Nature* 250:542–545.
- Simpson, B. B. 1979. Quaternary biogeography of the high mountain regions of South America. Pp. 157–188 in W. E. Duellman (ed.), *The South American herpetofauna: its origin, evolution, and dispersal*. University of Kansas Museum of Natural History Monograph 7:1–485.
- Tosi, J. A., Jr. 1960. *Zonas de Vida Natural en el Peru*. Turrialba, Costa Rica: Instituto Interamericano de Ciencias Agrícolas.
- Trueb, L., and W. E. Duellman. 1978. An extraordinary new casque-headed marsupial frog (Hylidae: *Gastrotheca*). *Copeia* 1978:498–503.
- van der Hammen, T. 1974. The Pleistocene changes in vegetation and climate in tropical South America. *Journal of Biogeography* 1:3–26.
- van der Hammen, T., and A. M. Cleef. 1986. Development of the high Andean páramo flora and vegetation. Pp. 153–201 in F. Vuilleumier and M. Monasterio (eds.), *High Altitude Tropical Biogeography*. New York, London: Oxford Univ. Press.
- Zeil, W. 1979. *The Andes: A Geological Review*. Berlin: Gebrüder Borntraeger.

APPENDIX I
SPECIMENS EXAMINED

The specimens from the Andes of northern Peru and comparative material from elsewhere in Peru and from Ecuador are documented below, alphabetically by species. Localities are arranged alphabetically within departamentos or provinces, which also are arranged alphabetically within countries. Within a locality, specimens are listed chronologically by catalogue number following museum abbreviations, which are arranged alphabetically.

Eleutherodactylus acuminatus (17 specimens)

ECUADOR: *Prov. Morona-Santiago*: San José, 830 m, KU 146976. *Prov. Napo*: Limoncocha, KU 183523; Río Yasuní, KU 175105. *Prov. Sucumbíos*: Puerto Libre, 570 m, KU 123255–60; 15 km ENE Umbaqui, 720 m, KU 123254. *Prov. Pastaza*: Canelos, 530 m, KU 119473.

PERU: *Depto. Loreto*: San Jacinto, 175–190 m, KU 221995. *Depto. San Martín*: Río Cainarachi, 33 km NE Tarapoto 330 m, KU 209466; Río Shilcayo, near Tarapoto, 500 m, KU 209467; 15.4 km SW Zapatero, 950 m, KU 217308–10.

Eleutherodactylus anemerus (1 specimen)

PERU: *Depto. Piura*: El Tambo, 31 km [by road] ENE Canchaque, 2770 m, KU 219789 (holotype).

Eleutherodactylus araiodactylus (1 specimen)

PERU: *Depto. Amazonas*: 24 km [by road] SW Leimebamba, 3370 m, UF 40764 (holotype).

Eleutherodactylus ardalonyctus (4 specimens)

PERU: *Depto. San Martín*: Abra Tangarana, 7 km NE San Juan de Pacaysapa, 1080 m, KU 212299; Río Cerranayacu, 76 km [by road] NW Rioja, 1200 m, KU 212301 (holotype), 212310; 8 km [by road] NE Tarapoto, 680 m, KU 212300.

Eleutherodactylus atrabracus (2 specimens)

PERU: *Depto. Amazonas*: Cordillera Colán, E La Peca, 2963–3330 m, LSU 49144 (holotype), 45090.

Eleutherodactylus avicuporum (13 specimens)

PERU: *Depto. Amazonas*: 12 km [by trail] E La Peca, 1700 m, KU 288628, LSUMZ 39359, 39361, 39365 (holotype), 39366–68, 39370–72, 39374–75, 45089.

Eleutherodactylus bearsei (11 specimens)

PERU: *Depto. San Martín*: Cataratas Ahuashiyacu, 14 km [by road] NE Tarapoto, 730 m, KU 212268 (holotype), 212269–74, 217314–15; 30 km [by road] SW Zapatero, 500 m, KU 212275–76.

Eleutherodactylus bromeliaceus (9 specimens)

ECUADOR: *Prov. Morona-Santiago*: 8.8 km [by road] WSW Plan de Milagro, 2370 m, KU 202316–17; Río Piuntza, Cordillera del Cóndor, 1830 m, KU 146974; between Logroño and Yaupi, 1700, ANSP 29254, 29272, 29278. *Prov. Zamora-Chinchipe*: 22 km [by road] W Zamora, 1730 m, KU 141772.

PERU: *Depto. San Martín*: East slope Abra Pardo de Miguel, 2180 m, KU 212213–14.

Eleutherodactylus cajamarcensis (147 specimens)

ECUADOR: *Prov. Azuay*: Luz María, 1880 m, KU 221706–09. *Prov. Loja*: 5 km NE Cariamanga, 1870 m, KU 141896–909; 12 km [by road] NE Catacocha, 2060 m, KU 141890–95; 6.8 km [by road] E Loja, 2640 m, KU 217851–52; 9 km [by road] E Loja, 2660 m, KU 119949–50; 12 km [by road] S Loja, KU 2250 m, KU 165190–92; 6 km [by road] N San Lucas, 2850–2900 m, KU 165193–99, 120007–15; 7–8 km [by road] N San Lucas, 2940–3000 m, KU 119951–120006; 13 km [by road] E Veracruz, 2250 m, KU 141860–89.

PERU: *Depto. Cajamarca*: San Andres de Cutervo, KU 221706–09. *Depto. Piura*: between Canchaque and Huancabamba, 3100 m, KU 135495, 135502; 25.5 km [by road] SW Huancabamba, 3010 m, KU 181250–61; 26 km SW [by road] Huancabamba, 3050 m, KU 196508; 29.3 km [by road] SW Huancabamba, 3100 m, KU 181244–49.

Eleutherodactylus ceuthospilus (53 specimens)

PERU: *Depto. Cajamarca*: 12 km [by road] W Lamas, 1500 m, KU 212215–18. *Piura*: 15–16 km [by road] ENE Canchaque, 1735–1840 m, KU 181270, 181272–78, 196492–98, 219775 (holotype), 219776–85, LSUMZ 32321–31, MHNSM 15387–97; 29 mi (46 km) [by road] E Canchaque, 9200 ft (2840 m), UF 34103.

Eleutherodactylus citriogaster (22 specimens)

PERU: *Depto. San Martín*: Cataratas Ahuashiyacu, 14 km [by road] NE Tarapoto, 730 m, KU 212277 (holotype), 212278–85, 217316, 217339–42, MHNSM 6080–82; Río Cainarachi, 33 km [by road] NE Tarapoto, 330 m, KU 209384; 8 km [by road] NE Tarapoto, 680 m, KU 212286; 18 km [by road] NE Tarapoto, KU 209483; 28 km [by road] NE Tarapoto, KU 212289–90.

Eleutherodactylus colodactylus (131)

ECUADOR: *Prov. Loja*: 14 km [by road] E Loja, 2770 m, KU 142160–61; 15 km [by road] E Loja, 2710 m, KU 142162–64. *Prov. Zamora-Chinchipe*: Abra de Zamora, 2800 m, KU 142151–54, 142156–59, 165219–21.

PERU: *Depto. Piura*: 23 mi (37 km) [by road] E Canchaque, 9300 ft (2870 m), UF 52077–89, 52091–138, 112513–33; 31 km [by road] SW Huancabamba, 3080 m, KU 181262–64; 33 km [by road] SW Huancabamba, 3050 m, KU 196443–46; Summit of Cordillera de Huancabamba (on road between Canchaque and Huancabamba), 3100 m, KU 135494, 135496–501.

Eleutherodactylus condor (48 specimens)

ECUADOR: *Prov. Morona-Santiago*: “Camp 3,” Cordillera de Cutucú, 1975 m, ANSP 29235, 29255–56, 29258; Río Piuntza, Cordillera del Cóndor, KU 146991, 146992 (holotype), 146993–147033.

PERU: *Depto. Amazonas*: upper Río Comainas, base of Cerra Machinaza, 1750, USNM 525437.

Eleutherodactylus crytomelas (6 specimens)

ECUADOR: *Prov. Loja*: 15 km [by road] E Loja, 2710 m, KU 141992–93; 8–9 km [by road] N San Lucas, 3000–3100 m, KU 120995–96.

PERU: *Depto. Piura*: El Tambo, 31 km [by road] ENE Canchaque, 2770 m, KU 181269, MHNSM 15398.

Eleutherodactylus cuneirostris (1 specimen)

PERU: *Depto. Amazonas*: 12 km [by trail] E La Peca, 1700 m, LSUMZ 39369 (holotype).

Eleutherodactylus exoristus (16 specimens)

ECUADOR: *Prov. Morona-Santiago*: Río Piuntza, Cordillera del Cóndor, 1830 m, KU 147047–50, 147051 (holotype), 147052–58.

PERU: *Depto. Amazonas*: Alfonso Ugarte, upper Río Comainas, 1138 m, USNM 525448, 525462, 525470; Puesto Vigilancia Río Comainas, 665 m, USNM 525442.

Eleutherodactylus galdi (15 specimens)

ECUADOR: *Prov. Morona-Santiago*: “Camp 2,” 1700 m, Cordillera de Cutucú, ANSP 29245, 29247; “Camp 3,” 1975 m, Cordillera de Cutucú, ANSP 29248; Río Piuntza, Cordillera del Cóndor, KU 146977–85. *Prov. Napo*: Río Azuela, 1740 m, KU 143416, 165422.

PERU: *Depto. Amazonas*: 12 km [by trail] E La Peca, Cordillera Colán, LSUMZ 39362.

Eleutherodactylus incomptus (63 specimens)

ECUADOR: *Prov. Napo*: Río Azuela, 1740 m, KU 143497; Río Salado, ± 1 km upstream from Río Coca, 1410 m, KU 146169, 165844–58, 177298–319; 2 km [by road] SSW Río Reventador, 1490 m, KU 165932; 16.5 km

[by road] NNE Santa Rosa, 1700 m, KU 143455, 143461–64, 143484 (holotype), 143485–96. *Prov. Pastaza*: 9.5 km [by road] NW Mera, 1270 m, KU 179000–03.

PERU: *Depto. Cajamarca*: Santa Rosa de la Yunga, KU 217319–20.

Eleutherodactylus infraguttatus (6 specimens)

PERU: *Depto. San Martín*: East slope Abra Pardo de Miguel, 2180 m, KU 212297 (holotype), 212298, 212314–16; 14 km [by road] W Venceremos, 2000 m, KU 217317.

Eleutherodactylus lanthanites (50 specimens)

ECUADOR: *Prov. Sucumbios*: Santa Cecilia, 340 m, KU 123852–77, 126215–16, 146144 (holotype), 146145–60.

PERU: *Depto. Loreto*: junction Río Yanomono and Río Amazonas, KU 220446, 220898; San Jacinto, 175–190 m, KU 222000–01. *Depto. San Martín*: Venceremos, 1630 m, KU 212225.

Eleutherodactylus lirellus (27 specimens)

PERU: *Depto. San Martín*: Abra Tangarana, 7 km [by road] NW San Juan de Pacaysapa, 1080 m, KU 212240 (holotype), 212241, 212251–59; Ponga de Shilcayo, 4 km [by road] NNW Tarapoto, 470 m, KU 212260–63; Río Cerranayacu, 76 km [by road] NW Rioja, 1200 m, KU 212226–32, 212234, 212236–39.

Eleutherodactylus lymani (34 specimens)

ECUADOR: *Prov. Azuay*: 55.9 km [by road] E Pasaje, 1000 m, KU 152009. *Prov. Loja*: Loja, 2150 m, KU 119502; 2 km [by road] E Loja, 2210 m, 3.9 km [by road] E Loja, 2460 m, KU 202418; KU 119504–12; 7 km [by road] E Loja, 2500 m, KU 119503; 9 km [by road] E Loja, KU 202416; 7.6 km [by road] S Loja, 2210 m, KU 141962–64; 9 km [by road] S Loja, 2230 m, KU 165539–40; 12.2 km [by road] S Loja, 2275 m, KU 141292; 14.4 km [by road] S Loja, 2260 m, KU 202417; 17 km [by road] NE Macará, 1240 m, KU 141965.

PERU: *Depto. Cajamarca*: 28 km [by road] N Santa Cruz, 725 m, KU 196464, 196509, LSUMZ 19553. *Depto. Piura*: Canchaque, 1120 m, MHNSM 11172; 15 km [by road] E Canchaque, 1850 m, KU 196465–69, 181265–67.

Eleutherodactylus melanogaster (5 specimens)

PERU: *Depto. Amazonas*: north slope Abra Barro Negro, 28 km [by road] SSW Leimebamba, 3470 m, KU 212321 (holotype), 212322–23, 218513; 25.5 km [by road] SSW Leimebamba, 3300 m, KU 181281.

Eleutherodactylus metabates (2 specimens)

PERU: *Depto. Amazonas*: 20 km [by road] SW Chiriaco, 525 m, KU 196504 (holotype), LSUMZ 32460.

Eleutherodactylus muscosus (4 specimens)

PERU: *Depto. San Martín*: east slope Abra Pardo de Miguel, 1800 m, KU 200479–81, 2094782 (holotype).

Eleutherodactylus nephophilus (8 specimens)

PERU: *Depto. San Martín*: Abra Tangarana, 7 km [by road] E San Juan de Pacaysapa, 1080 m, KU 212311; east slope Abra Pardo de Miguel, 2180 m, KU 212305, 212306 (holotype), 212307–09, 212317; 14 km [by road] W Venceremos, 2000 m, KU 212311.

Eleutherodactylus ockendeni (71 specimens)

PERU: *Depto. Amazonas*: 4 km [by road] SW Chiriaco, 725 m, KU 196470. *Depto. Cuzco*: Atalaya, 650 m, KU 154797–99, 154805. *Depto. Huánuco*: Finca Panguana, Río Lullapichis, KU 154761–78, 154804, 171831–48; south slope Serranía de Sira, 690–1280 m, KU 154779–85. *Depto. Loreto*: junction Río Sucusari and Río Napo, KU 220356–57, 220449; San Jacinto, 175–190 m, KU 222021; Teniente López, 200 m, KU 222022; 1.5 km N Teniente López, 310–340 m, KU 222023. *Depto. Madre de Dios*: Cocha Cashu, 400 m, KU 154788–96; Manu, 365 m, KU 154786, 154866. *Depto. San Martín*: Río Cainarachi, 33 km [by road] NE Tarapoto, 330 m, KU 209468–71.

Eleutherodactylus pataikos (1 specimen)

PERU: *Depto. Amazonas*: north slope Abra Barro Negro, 28 km [by road] SSW Leimebamba, 3470 m, KU 212320 (holotype).

Eleutherodactylus pecki (9 specimens)

ECUADOR: *Prov. Morona-Santiago*: Río Piuntza, 1550 m, Cordillera del Cóndor, KU 147040 (holotype), 147041–42; trail between Logroño and Yaupi, 1700 m, ANSP 29271, 29273–77.

PERU: *Depto. Amazonas*: Alfonso Ugarte, Río Comainas, 1138 m, USNM 525476.

Eleutherodactylus percnopterus (24 specimens)

PERU: *Depto. Amazonas*: Alfonso Ugarte, Río Comainas, 1138 m, USNM 525445–46, 525449–63; 20 km [by road] SW Chiriaco, 525 m, KU 196506; 33 km [by road] SE Ingenio, 1830 m, KU 196505, LSUMZ 32462–63; 5 km [by road] NW Mendoza, 2400 m, KU 209472; upper Río Comainas, base of Cerro Machinaza, 1750 m, USNM 525443; Santa Rosa de la Yunga, 1300 m, KU 217318 (holotype).

Eleutherodactylus peruvianus (79 specimens)

ECUADOR: *Prov. Morona-Santiago*: “Camp 2,” Cordillera de Cutucú, ANSP 29234, 29237–44, 29249–50, 29259, 29264; “Camp 3,” Cordillera de Cutucú, ANSP 29286; Río Pintza, Cordillera del Cóndor, 1830 m, KU 147034–38; trail between Logroño and Yaupi, ANSP 29236.

PERU: *Depto. Amazonas*: Puesto Vigilancia, Río Comainas, 665 m, USNM 525440; upper Río Comainas, base of Cerro Machinaza, 1750 m, USNM 525438–39. *Depto. Ayacucho*: Estero Ruana in Tambo-Valle de Apurimac trail, 1800 m, KU 196473; Huanuachayoc in Tambo-Valle de Apurimac trail, 1650 m, KU 196472, 196474. *Depto. Huánuco*: Finca Panguana, Río Lullapichis, KU 154835–47, 154858–62, 1718667–91; South slope Serranía sw Sira, 690 m, KU 154848–52, 154863–68. *Depto. Loreto*: Quebrada Orán, 5 km N Río Amazonas, 85 km NE Iquitos, KU 206094; Quebrada Vainilla, 10 km SSW mouth of Río Napo, KU 206093; Teniente López, 200 m, KU 222030; 1.5 km N Teniente López, 310–340 m, KU 222024–29. *Depto. Pasco*: Santa Cruz, 9 km [by road] SSE Oxapampa, 2050 m, KU 206095–97. *Depto. San Martín*: Abra Tangarana, 7 km [by road] NE San Juan de Pacaysapa, 1080 m, KU 212291; Río Cainarachi, 33 km [by road] NE Tarapoto, 330 m, KU 208475–77; 20 km [by road] NE Tarapoto, KU 209473–74; 40 km [by road] NE Tarapoto, KU 217312; 15.4 km [by road] SW Zapatero, 950 m, KU 217313.

Eleutherodactylus petrobardus (7 specimens)

PERU: *Depto. Cajamarca*: 2 km [by road] W Huambos, 2500 m, KU 212292 (holotype), 212293–96, MHNSM 6196–97.

Eleutherodactylus phoxocephalus (36 specimens)

ECUADOR: *Prov. Azuay*: 10 km [by road] SW Victoria del Portete, 2700 m, KU 131281–82. *Prov. Cañar*: 18.4 km [by road] NW El Tambo, 2860 m, KU 142118–31. *Prov. Loja*: Río Zamora, 6.5 km [by road] N Loja, 2060 m, KU 142113; Saraguro, 2500 m, KU 135460–62; 3.3 km [by road] NNE Saraguro, 2400 m, KU 142117; 2 km [by road] S Saraguro, 2680 m, KU 142114–16. *Prov. Zamora-Chinchipec*: 15 km [by road] E Loja, 2710 m, KU 142104–12.

PERU: *Depto. Cajamarca*: San Andres de Cutervo, KU 221710–13. *Depto. Piura*: 15 km [by road] ENE Canchaque, 1850 m, KU 181271; El Tambo, 31 km [by road] ENE Canchaque, 2770 m, MHNSM 15399.

Eleutherodactylus pinguis (4 specimens)

PERU: *Depto. Cajamarca*: 57 km [by road] N Cajamarca, 3760 m, UF 40766; 23 km [by road] SW Celendín, 3050 m, KU 181282, 181283 (holotype); 33 km [by road] SW Celendín, 3200 m, KU 181284.

Eleutherodactylus proserpens (10 specimens)

ECUADOR: *Prov. Loja*: Abra de Zamora, 15 km [by road] E Loja, 2800 m, KU 202130–31. *Prov. Morona-Santiago*: “Camp 2,” 1700 m, Cordillera de Cutucú, ANSP 29230–33; Río Piuntza, 1830 m, Cordillera del Cóndor, KU 147044–46.

PERU: *Depto. Amazonas*: Upper Río Comainas, base of Cerro Machinaza, 1750 mm, USNM 525447.

Eleutherodactylus quaquaversus (52 specimens)

ECUADOR: *Prov. Morona-Santiago*: “Camp 2,” 1700 m, Cordillera de Cutucú, ANSP 29257, 29263, 29265–66, 29270, 29281, 29283–85; Río

Piuntza, 1830 m, Cordillera del Cóndor, KU 146987–90. *Prov. Napo*: Río Azuela, 1740 m, KU 143448–54; 2 km [by road] SSW Río Reventador, 1490 m, KU 165563–65; Río Salado, ± 1 km upstream from Río Coca, 1410 m, KU 165566–85; 16.5 km [by road] NNE Santa Rosa, 1700 m, KU 143441–47.

PERU: *Depto. Amazonas*: Upper Río Comainas, base of Cerro Machinaza, 1750 m, USNM 525444. *Depto. Loreto*: 1.5 km N Teniente López, 310–340 m, KU 222031.

Eleutherodactylus rhodoplichus (24 specimens)

PERU: *Depto. Piura*: El Tambo, 31 km [by road] ENE Canchaque, 2770 m, KU 219786 (holotype), 219787–91, MHNSM 15400–04; 12.7 km [by road] NE El Tambo, 2820 m, KU 219792; crest of Cordillera de Huancabamba, 33 km [by road] SW Huancabamba, 3050 m, KU 196499–503, LSUMZ 32417, 32428–33.

Eleutherodactylus rhodostichus (4 specimens)

PERU: *Depto. San Martín*: West slope Abra Tangarana, 7 km [by road] NE San Juan de Pacaysapa, 1080 m, KU 212264 (holotype), 212265–67.

Eleutherodactylus rufioculis (10 specimens)

PERU: *Depto. Amazonas*: Alfonso Ugarte, Río Comainas, 1138 m, USNM 525474–75; Upper Río Comainas, base of Cerro Machinaza, 1750 m, USNM 525464–65, 525467–68, 525473–74. *Depto. San Martín*: East slope Abra Pardo de Miguel, 2180 m, KU 212312, 212313 (holotype).

Eleutherodactylus schultei (16 specimens)

PERU: *Depto. Amazonas*: 5 km [by road] N Levanto, 2850 m, KU

212220–21, 212222 (holotype), 212223–24, 209496–97, MHNSM 6172–73; 5 km [by road] NW Mendoza, 2400 m, KU 209498–504.

Eleutherodactylus serendipitus (5 specimens)

PERU: *Depto. Amazonas*: 8 km [by road] NNE Balzapata, 1850 m, KU 181279 (holotype), 181280; 12 km [by trail] E La Peca, Cordillera Colán, LSUMZ 39360, 39363, 39377.

Eleutherodactylus sternothylax (49 specimens)

PERU: *Depto. Piura*: 15 km [by road] ENE Canchaque, 1735 m, 196479–91, LSUMZ 32320, 32332–50, 32352, 32418–27, 32458; 16 km [by road] ENE Canchaque, 1840 m, KU 219793 (holotype), 212794, MHNSM 15405–06.

Eleutherodactylus versicolor (69 specimens)

ECUADOR: *Prov. Loja*: 13.5 km [by road] E Loja, 2800 m, KU 1198858 (holotype), 119859–71, 119911–44, 141449–60, 141465–66; 8–9 km [by road] N San Lucas, 3000–3100 m, KU 119945.

PERU: *Depto. Amazonas*: Alfonso Ugarte, Río Comainas, 1138 m, USNM 525469, 525471–72; Puesto Vigilancia Río Comainas, 665 m, USNM 525441; Upper Río Comainas, base of Cerro Machinaza, 1750 m, USNM 525466, 525477.

Eleutherodactylus wiensi (7 specimens)

PERU: *Depto. Piura*: 12.7 km [by road] ENE Canchaque, 1600 m, KU 219795 (holotype), 219706–97, MHNSM 15407–08; 15 km [by road] ENE Canchaque, 1735 m, KU 196510–11.

APPENDIX 2

GAZETTEER

Following is a list of localities in the Andes of northern Peru where specimens of *Eleutherodactylus* were collected. After each place name the departamento is given in parentheses, followed by geographic coordinates, elevation, and vegetation type. Except for localities on the eastern slope of the Cordillera del Cóndor documented by Reynolds and Icochea (1997), coordinates were determined from maps (Mapa Físico Político del Perú, 1:1,000,000, 1973, and Carta Nacional del Perú, 1:100,000, 1986). Elevations were obtained from altimeter readings or from maps. When known, specific sites and habitats are given followed by names of collectors (only those responsible for field notes) and the month and years that they collected at the sites. Names of collectors are abbreviated: AM = Alfonso Miranda, ERW = Erik R. Wild, FRG = Fred G. Thompson, GKN = G. K. Noble, KLC = Kenneth L. Campbell, LSU = Louisiana State University ornithologists; RPR = Robert P. Reynolds, RAM = Russell A. Mittermeier, RS = Rainer Schulte, RT = Richard Thomas, WED = William E. Duellman. All localities are shown on the map (Fig. 1).

Abra Barro Negro (Amazonas)—06°41' S, 77°51' W, 3500 m; very humid montane forest. A pass in the Cordillera Central on the road between Balsas and Leimebamba. Collections made on the north slope along the road at 25.5 km SSW of Leimebamba, 3300 m, and 28 km SSW of Leimebamba 3470 m in January 1989 by WED. At both sites there were few trees; dominant vegetation consisted of small shrubs (*Baccharis*), bunch grass, ferns, scattered flower herbs, and mosses 10–20 cm deep.

Abra Pardo de Miguel (Amazonas-San Martín)—05°46' S, 77°42' W, 2210 m; very humid montane forest. A pass in the eastern range of the Cordillera Central. Collections made on the east slope at about 1800 m in January 1981 by RS and just below the crest on the road to La Rioja, at an elevation of 2180 m in January 1989 by WED. Many trees laden with

bromeliads, tree ferns, spiny bamboo (*Chusquea spicata*) and broad-leaved *Gunnera*; rocky cliffs covered with mosses and lichens.

Abra Tangarana (San Martín)—06°12' S, 76°44' W, 1120 m; humid subtropical forest. A pass in a low ridge of the Cordillera Central, 7 km NE of the small village San Juan de Pacaysapa on the road between Moyobamba and Tarapoto. Collections were made in a rocky ravine on the western slope by WED in February 1989. Trees in the forest held many bromeliads; elephant-ear plants (*Xanthosoma*) were abundant along the stream.

Alfonso Ugarte (= Puesto Vigilancia 3) (Amazonas)—03°54' S, 78°25' W, 1138 m; humid montane forest. Military post on the upper Río Comainas, eastern slope of Cordillera del Cóndor. Collections made in July–August 1994 by RPR.

Alva (Amazonas)—Approximately 05°53' S, 78°56' W, 1000 m; presumably thorn forest. Site on slopes of Cordillera Central above Pedro Ruiz Gallo in Río Utcubamba Valley. Collection in May 1974 by RAM.

Balzapata (Amazonas)—05°46' S, 77°51' W, 1640 m; humid montane forest. A village just west of the crest of the Cordillera Central. Collections made in disturbed and partly cultivated forest 8 km NNE (1850 m) on the road to La Rioja in March 1979 by WED.

Cajamarca (Cajamarca)—07°12' S, 78°30' W, 2750 m; montane dry forest. City in Cordillera Occidental. Collection from grassland in humid montane forest at 3750 m, 57 km N of Cajamarca in April 1972 by FGT.

Canchaque (Piura)—05°22' S, 79°36' W, 1120 m; tropical dry forest. A town near the western base of the Cordillera de Huancabamba. Collections were made in dry forest near the town and humid montane forest at varying distances from the town on the road across the Cordillera de Huancabamba to the town of Huancabamba in April 1970 by KLC, December 1974 by RT, March 1979 by WED, and January 1991 by ERW.

Cataratas Ahuashiyacu (San Martín)—06°30' S, 76°20' W, 730 m; humid subtropical forest. Waterfall and rocky stream in deep ravine 14 km NNE of Tarapoto on the road to Yurimaguas. Collections in February 1989 by WED.

Celendín (Cajamarca)—06°52' S, 78°08' W, 2625 m; humid montane forest. City in the Cordillera Occidental. Collections from the east slope of Abra Comulica, 23 km SW (3050 m) and 33 km SW (3200 m) of Celendín

in March 1979 by WED. Both sites heavily disturbed, mostly grassy marsh (3050 m) and bunch-grass-*Baccharis* association.

Chiriaco (Amazonas)—05°09' S, 78°21' W, ± 450 m; thorn forest. Town on the Río Marañón at the confluence of the Río Chiriaco. Collections made in dry forests 4 km SW and 20 km SW (525 m) on road to Bagua in December 1974 by RT.

El Tambo (Piura)—05°21' S, 79°33' W, 2770 m; humid montane forest. Settlement on the western slope of the Cordillera de Huancabamba, 31 km NNE of Canchaque on the road to Huancabamba. Collections in relatively undisturbed forest in March 1979 by WED and January 1991 by ERW.

Huambos (Cajamarca)—06°27' S, 78°57' W, ± 2200 m; montane dry forest. Town on the western slopes of the Cordillera Occidental. Collections from "pre-Incan ruins" in 1916 by GKN and in scrubby forest with terrestrial bromeliads 2 km W (2500 m) in February 1989 by WED.

Huancabamba (Piura)—05°14' S, 79°28' W, 1957 m; dry forest. City on the Río Huancabamba at eastern base of the Cordillera de Huancabamba; area in immediate vicinity mostly cultivated. Collections from very humid montane forest just east of and at the crest of the Cordillera de Huancabamba, 25–26 km SW (3010–3050 m) in March 1979 by WED and 31–33 km SW (5050–3100 m) in December 1974 by RT and in March 1979 by WED.

Ingenio (Amazonas)—05°55' S, 78°55' W, 1280 m; thorn forest. Settlement in the Río Utucubamba Valley. Collection from dry forest on slopes of Cordillera Central 33 km SE (1830 m) on road to Chachapoyas in December 1974 by RT.

Lamas (*Llama*) (Cajamarca)—06°31' S, 79°07' W, ± 2200 m; thorn forest. Village in valley on west slope of Cordillera Occidental. Collection from 12 km W (1500 m) in December 1974 by RT.

La Peca (Amazonas)—05°36' S, 78°22' W, ± 1400 m; thorn forest. Village near western base of Cordillera Colán. Collections from the Cordillera Colán—humid montane forest 12 km (by trail) E (1700 m) and very humid montane forest E (2963–3330 m) in August–September 1978 by LSU.

Leimebamba (Amazonas)—06°33' S, 77°49' W, 2200 m; humid montane forest. Town in the upper Río Utucubamba drainage in the Cordillera Central. Collection from 24 km (by road) SW, 3370 m in very humid montane forest in April 1972 by FGT.

Levanto (Amazonas)—06°17' S, 77°21' W, 2650 m; humid montane forest. Village south of Chachapoyas in the Cordillera Central. Collection from bromeliad-laden trees in highly disturbed forest 5 km N (2850 m) in January 1989 by WED.

Mendoza (Amazonas)—06°18' W, 77°25' W, 1650 m; humid montane forest. Town in the Cordillera Central. Collection from pass (headwaters of Río Chiriaco) 5 km NW (2400 m) in July 1981 by RS.

Palambla (Piura)—05°23' S, 79°36' W, 1120 m; tropical dry forest. Village near the western base of the Cordillera de Huancabamba. Collection in 1916 by GKN.

Perico (Cajamarca)—05°22' S, 78°47' W, ± 1000 m; thorn forest. Village in Río Marañón Valley; collection in 1916 by GKN.

Puesto Vigilancia Comainas, Río Comainas (Amazonas)—04°06' S, 78°23' W, 665 m; humid subtropical forest. Military camp on the west bank of the Río Comainas, eastern slope of Cordillera del Cóndor. Collections made in July–August 1994 by RPR.

Río Cerranayacu (San Martín)—05°46' S, 77°27' W, 1200 m; humid montane forest. Tributary of the Río Mayo on the eastern flank of the Cordillera Central. Collection from narrow valley near crossing of the Balzapata–La Rioja road in February 1989 by WED.

Río Comainas, base of Cerro Machinaza (Amazonas)—03°53' S, 78°25' W, 1750 m; humid montane forest. Site on the eastern slopes of the Cordillera del Cóndor. Collection in July–August 1994 by RPR.

San Andres de Cutervo (Cajamarca)—05°14' S, 78°42' W, ± 2500 m; humid montane forest. Village in the Cordillera Occidental. Collection in June and December 1992 by AM.

Santa Cruz (Cajamarca)—06°05' S, 78°51' W, ± 1300 m; thorn forest. Village in the Río Chamaya Basin. Collection from 28 km N (725 m) in December 1974 by RT.

Santa Rosa de la Yunga (Cajamarca)—06°05' S, 78°43' W, 1000 m; dry forest. Village on the southern slope of Cordillera del Cóndor. Collection from disturbed dry forest immediately above village in July 1989 by RS.

Tarapoto (San Martín)—06°31' S, 76°23' W, 370 m; humid tropical forest. Town near confluence of Río Mayo and Río Huallaga just east of Cordillera Central. Collections from various distances and elevations in February 1989 by RS and WED.

Venceremos (San Martín)—05°44' S, 77°31' W, 1630 m; humid montane forest. Former road camp and now small settlement on the road between Balzapata and La Rioja. Collections from immediate vicinity in February 1989 by WED and from 14 km W (2000 m on road to Balzapata) in July 1981 by RS.

Zapatero (San Martín)—06°34' S, 76°30' W, 320 m; humid tropical forest. Village at base of hills north of the Río Huallaga. Collections from disturbed humid montane forest 15.4 km SW (950 m) in June 1989 by RS and from ravine in cutover humid tropical forest 30 km SW in February 1989 by WED.



~~NEW~~

DATE DUE

DATE DUE	
MAY 04 2008	perm loan

PUBLICATIONS OF THE NATURAL HISTORY MUSEUM, THE UNIVERSITY OF KANSAS

The University of Kansas Publications, Museum of Natural History, beginning with Volume 1 in 1946, was discontinued with Volume 20 in 1971. Shorter research papers formerly published in the above series were published as The University of Kansas Natural History Museum Occasional Papers until Number 180 in December 1996. The Miscellaneous Publications of The University of Kansas Natural History Museum began with Number 1 in 1946 and ended with Number 68 in February 1996. Monographs of The University of Kansas Natural History Museum were initiated in 1970 and discontinued with Number 8 in 1992. The University of Kansas Science Bulletin, beginning with Volume 1 in 1902, was discontinued with Volume 55 in 1996. The foregoing publication series are now combined in a new series entitled Scientific Papers, Natural History Museum, The University of Kansas, begun with Number 1 in 1997. Special Publications began in 1976 and continue as an outlet for longer contributions and are available by purchase only. All manuscripts are subject to critical review by intra- and extramural specialists; final acceptance is at the discretion of the editor.

The publication is printed on acid-free paper. Publications are composed using Microsoft Word® and Adobe PageMaker® on a Macintosh computer and are printed by The University of Kansas Printing Services.

Institutional libraries interested in exchanging publications may obtain the Scientific Papers, Natural History Museum, The University of Kansas, by addressing the Exchange Librarian, The University of Kansas Libraries, Lawrence, Kansas 66045-2800, USA. Available back issues of The University of Kansas Science Bulletin may be purchased from the Library Sales Section, Retrieval Services Department, The University of Kansas Libraries, Lawrence, Kansas 66045-2800, USA. Available issues of former publication series, Scientific Papers, and Special Publications of the Natural History Museum can be purchased from the Office of Publications, Natural History Museum, The University of Kansas, Lawrence, Kansas 66045-2454, USA. Purchasing information can be obtained by calling (785) 864-4450, fax (785) 864-5335, or e-mail (kunhm@ukans.edu). VISA and MasterCard accepted; include expiration date.

SERIES EDITOR: William E. Duellman

EDITOR FOR THIS NUMBER: Linda Trueb

PRINTED BY
THE UNIVERSITY OF KANSAS PRINTING SERVICES
LAWRENCE, KANSAS

MCZ
LIBRARY

MAR 29 2000

HARVARD
UNIVERSITY