

UNIVERSITY OF TORONTO



3 1761 01444410 3

Digitized by the Internet Archive  
in 2008 with funding from  
Microsoft Corporation

SEEN BY  
PRESERVATION  
SERVICES

DATE.....

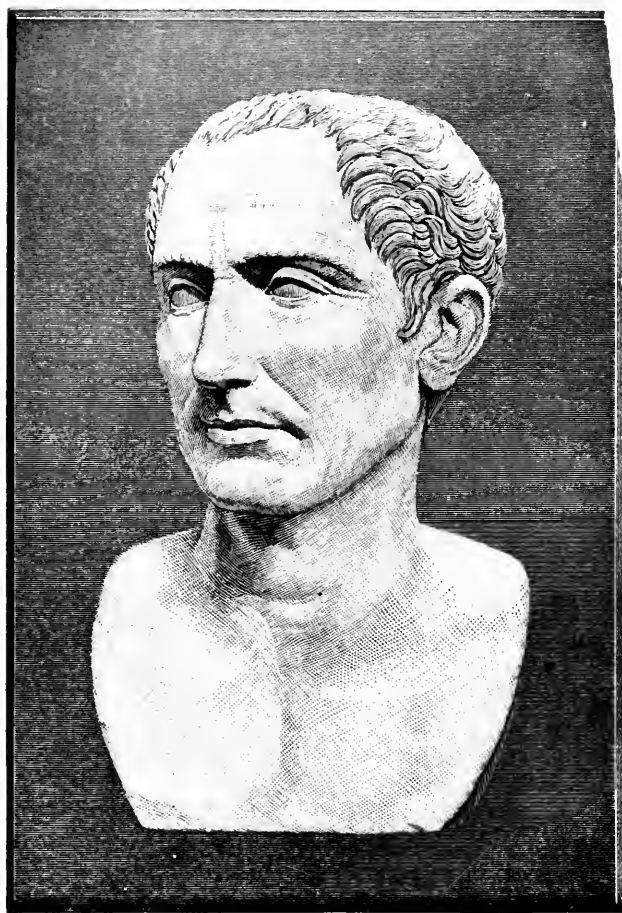

CÆSAR

FROM A COLOSSAL BUST IN THE MUSEUM AT NAPLES

AL  
51203-18 A. 2  
CL. 30m  
ALLEN & GREENOUGH'S LATIN SERIES

# CÆSAR'S GALLIC WAR

COMPLETE EDITION, INCLUDING  
SEVEN BOOKS

EDITED BY

J. H. AND W. F. ALLEN AND H. P. JUDSON

WITH NOTES AND DISSERTATIONS, FULLY ILLUSTRATED, ON  
CÆSAR'S GALLIC CAMPAIGNS AND THE ROMAN MILITARY  
ART, PREPARED BY H. P. JUDSON; AND A SPECIAL  
VOCABULARY, BY J. B. GREENOUGH.

182173  
8.7.23

Οὕτω δὲ ὁ θεὸς Καῖσαρ ἐν τοῖς ὑπομνήμασιν  
εἴρηκεν. — STRABO, iv. 1.

DEPARTMENTAL  
LIBRARY

BOSTON, U.S.A.:

PUBLISHED BY GINN & COMPANY.

1889.

Entered, according to Act of Congress, in the year 1886, by  
J. H. AND W. F. ALLEN AND H. P. JUDSON,  
in the Office of the Librarian of Congress, at Washington.

PA  
6235  
A2  
1889

## PREFACE.

---

IN preparing this completed edition of Cæsar's Gallic War, the notes on the earlier portion have been diligently revised and largely re-written. In general, the plan and substance, approved by wide and satisfactory use for eleven years, have been retained. Besides the grammatical references to Allen & Greenough's Grammar, which have been carefully verified, references are given to the grammars of Gildersleeve and Harkness. The map of Gaul has been corrected according to the latest investigations, and a large number of illustrations, diagrams, and battle-plans have been introduced from the most recent and trustworthy sources.

A still more important feature is the elaborate study of the Roman military art as exemplified in the campaigns of Cæsar, carefully prepared from the most recent authorities by Mr. H. P. Judson, Professor of History in the University of Minnesota, to whom its plan and execution are solely due. The special value of these military notes is quite apparent. The Commentaries are little more than a military history, — a story of battle and siege, — and to read the book understandingly the student must have a definite notion of the Roman army and its methods. This edition aims to enable him, with each sentence, to place before his eye a picture, — the same picture it suggested to the intelligent Roman reader.

The Vocabulary, by Professor Greenough, is on the same plan as his Vocabulary to Virgil. It attempts to give, first, the etymological meaning of each word as far as is possible; second, the general meanings of the words, representing the

conceptions as they appeared to the Romans ; third, such renderings as may be necessary to present the thought in a suitable English form. In the last case care is taken to indicate by the use of phrases and by notes the difference between the Roman and the English conceptions. In giving the etymologies, the actual mode of formation in each case, so far as it is known, is shown, and all the elements which have entered into the formation are noted. It is, of course, not intended that such etymological matter is to be studied as task-work by the pupil ; but both teachers and students will do well to form the habit of analyzing words in this manner rather than content themselves with vague notions about roots, and with loose connections of words.

This edition of Cæsar follows, with slight change of orthography, the text of Nipperdey, the more important various readings being given in the notes. It is believed to be an advantage even to the youngest learner to deal with a standard text, and to know something of those variations which make the reading of an ancient classic differ from that of a modern author. In illustration of the narrative, constant use has been made of the more recent authorities, Mommsen, Kraner, Long, Merivale, and the "History of Julius Cæsar" by Napoleon III., with the excellent school edition of Moberley. Much care has been taken, with the earlier portion especially, to furnish in the notes a guide to the thorough study of syntactical construction, for which no author is, by general consent, so well adapted as Cæsar.



# CONTENTS.



	PAGE
THE LIFE OF CÆSAR .....	xi
BOOK I. HELVETIAN WAR; CAMPAIGN AGAINST ARIOVISTUS ..	1
BOOK II. THE BELGIAN CONFEDERACY.....	35
BOOK III. ALPINE CAMPAIGN; NAVAL CAMPAIGN; SOUTHERN GAUL .....	53
BOOK IV. CAMPAIGN AGAINST THE GERMANS; FIRST INVASION OF BRITAIN .....	69
BOOK V. SECOND INVASION OF BRITAIN; FRESH RISINGS OF THE GAULS.....	88
BOOK VI. SECOND EXPEDITION INTO GERMANY; ACCOUNT OF GAUL AND GERMANY; DEFEAT OF THE EBURONES AND SIGAMBRI.....	118
BOOK VII. UPRISING OF GAUL UNDER VERCINGETORIX.....	141

## NOTES.

### MILITARY NOTES.

The Legionary .....	1
The Roman Legion .....	17
Fortifications on the Rhone .....	20
The Personal Baggage.....	23
The Cavalry .....	34
The Order of Battle.....	35
The Gallic Array and Arms .....	37
The Military Standards.....	39
Relative Rank of the Centurions .....	49
The Camp.....	57

MILITARY NOTES ( <i>continued</i> ).	PAGE
<i>Legati</i> .....	64
Cæsar's Legions .....	66, 102, 117, 136, 149, 165, 192
Arrangement of the Cohorts in Camp .....	70
Camp Duties.....	71
<i>Tormenta</i> .....	75
The Siege.....	77
The Baggage Train.....	85
The March .....	86
Tactics of the Cavalry... ..	92
The Martial Music.....	94
The Winter Camp .....	104
Siege of the Coast Towns .....	110
The Mines .....	115
Bridge over the Rhine.....	125
The British Chariots.....	134
Strength of the Legion.....	135
The Circle ( <i>Orbis</i> ).....	136
The <i>Agger</i> in Britain.....	140
The Council of War .....	145
<i>Turres</i> .....	147
Position at Avaricum.....	170
<i>Agger</i> at Avaricum.....	173
Position at Gergovia .....	177, 179
Position at Alesia.....	185
Roman Works at Alesia .....	188-192



FRANCE.

For comparison with the Map of Gaul.



## LIST OF ILLUSTRATIONS.



Caesar .....	<i>Frontispiece</i>
Map of Gaul .....	xxii, xxiii
Map of France.....	to face p. I

	NOTES, PAGE
The Legionary .....	2
Fig. 1. <i>Scutum</i> .....	4
“ 2. <i>Gladius</i> .....	4
“ 3. <i>Pilum</i> .....	4
“ 4. <i>Centurio</i> .....	18
Plan I. Fortifications on the Rhone .....	20
Fig. 5. Roman Soldiers .....	23
“ 6. <i>Eques</i> .....	34
“ 7. The Maniple .....	35
Plan II. Battle with the Helvetians .....	36
Fig. 8. <i>Aquila</i> .....	39
“ 9. <i>Vexillum</i> .....	39
“ 10. <i>Signum</i> .....	39
“ 11. <i>Aquilifer</i> .....	40
“ 12. <i>Fossa Punica</i> .....	58
“ 13. <i>Fossa directis lateribus</i> .....	58
“ 14. Wall and Ditch.....	59
“ 15. <i>Castra Romana</i> .....	60
“ 16. Fortifying the Camp.....	61
Plan III. Battle with Ariovistus .....	65
“ IV. Battle on the Aisne.....	74
Fig. 17. <i>Catapulta</i> .....	75
“ 18. <i>Scorpio</i> .....	75
“ 19. <i>Ballista</i> .....	76
“ 20. <i>Pluteus</i> .....	78
“ 21. <i>Pluteus</i> .....	79
“ 22. <i>Pluteus</i> .....	80
“ 23. Portion of <i>Agger</i> .....	80

	PAGE
Fig. 24. Vertical Section of <i>Agger</i> and Wall .....	81
“ 25. General View of Siege Operations.....	82
“ 26. <i>Oppugnatio</i> .....	84
“ 27. Cohort in Line of Battle.....	87
“ 28. Legion in Line of Battle .....	88
“ 29. Cohort in Column of Maniples.....	87
“ 30. Cohort in Column of Centuries.....	87
“ 31. Cohort in Column of Centuries, 5 Files.....	87
“ 32. Legion marching by the Right Flank.....	88
“ 33. Legion marching to the Front.....	88
“ 34. Legion marching in Square.....	89
Plan V. Battle on the Sambre.....	93
Fig. 35. <i>Lituus</i> .....	95
“ 36. <i>Tuba</i> .....	95
“ 37. <i>Buccina</i> .....	95
Plan VI. Siege of Aduatuca .....	100
“ VII. Campaign against the Veneti .....	109
Fig. 38. Bridge over the Rhine.....	126
“ 39. The Attack with Chariots.....	134
“ 40. Ground Plan of Gallic Wall .....	171
“ 41. Vertical Section of Gallic Wall.....	172
“ 42. Section of Roman <i>Agger</i> at Avaricum.....	172
Plan VIII. Siege of Avaricum .....	173
“ IX. Siege of Gergovia.....	176
Fig. 43. Sections of the Double Trench at Gergovia.....	178
Plan X. March of Labienus against Lutetia .....	182
Plan XI. Defeat of Vercingetorix on the Vingeanne.....	184
“ XII. Siege of Alesia .....	187
Fig. 44. Section of Contravallation at Alesia .....	188
“ 45. <i>Lilium</i> .....	189



4 Longitude West 2 0 2 East from 4 Greenwich 6 8 10

Map No. 1.

# GAUL

IN THE TIME OF CÆSAR.

ENGLISH STATUTE MILES.

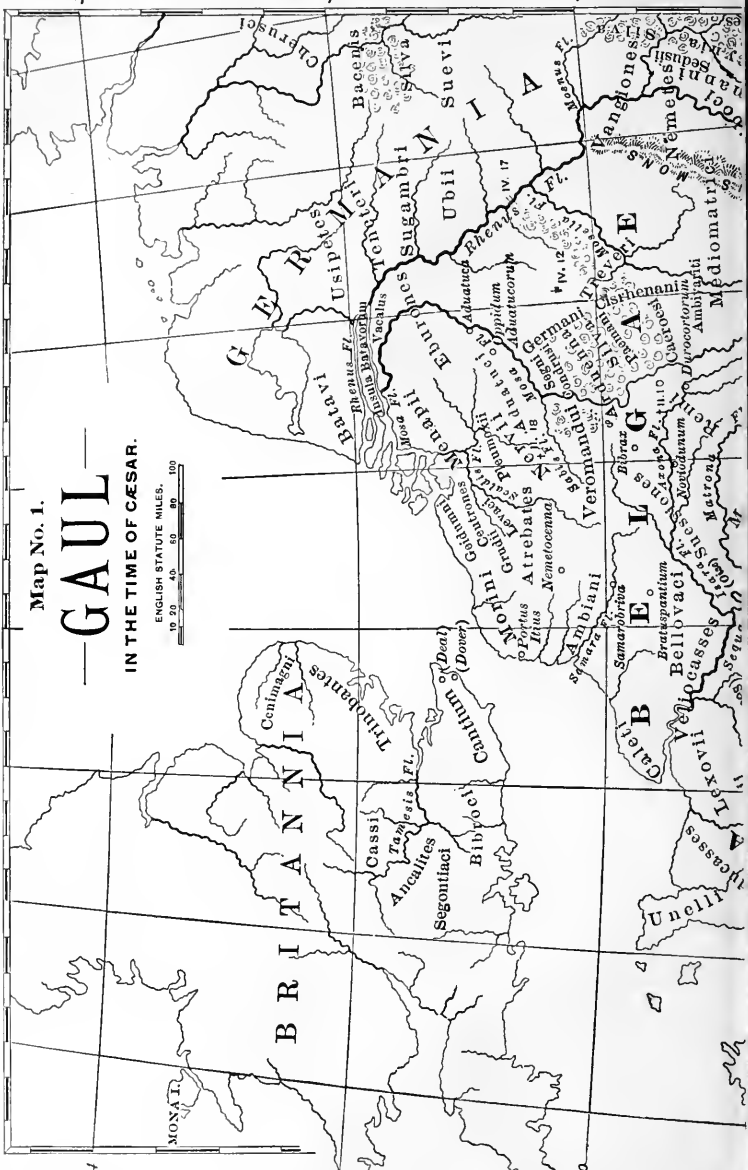

54

52

50

54

50

MONA I.

Contuagri

Triobantes

CASSI

Tamesis Fl.

Ancalites

Segontiaci

Bibolci

Calturno (Dover)

Calturno

Atreates

Atreates

Atreates

Atreates

Atreates

Atreates

Atreates

Atreates

Atreates

Atreates

Atreates

Atreates

Atreates

Atreates

Atreates

Atreates

Atreates

Atreates

Atreates

Atreates

Atreates

Atreates

Atreates

Atreates

Atreates

Atreates

Atreates

Atreates

Atreates

Atreates

Atreates

Atreates

Atreates

Atreates

Atreates

Atreates

Atreates

Atreates

Atreates

Atreates

Atreates

Atreates

Atreates

Atreates

Atreates

Atreates

Atreates

Atreates

Atreates

Atreates

Atreates

Atreates

Atreates

Atreates

Atreates

Atreates

Atreates

Atreates

Atreates

Atreates

Atreates

Atreates

Atreates

Atreates

Atreates

Atreates

Atreates

Atreates

Atreates

Atreates

Atreates

Atreates

Atreates

Atreates

Atreates

Atreates

Atreates

Atreates

Atreates

Atreates

Atreates

Atreates

Atreates

Atreates

Atreates

Atreates

Atreates

Atreates

Atreates

Atreates

Atreates

Atreates

Atreates

Atreates

Atreates

Atreates

Atreates

Atreates

Atreates

Atreates

Atreates

Atreates

Atreates

Atreates

Atreates

Atreates

Atreates

Atreates

Atreates

Atreates

Atreates

Atreates

Atreates

Atreates

Atreates

Atreates

Atreates

Atreates

Atreates

Atreates

Atreates

Atreates

Atreates

Atreates

Atreates

Atreates

Atreates

Atreates



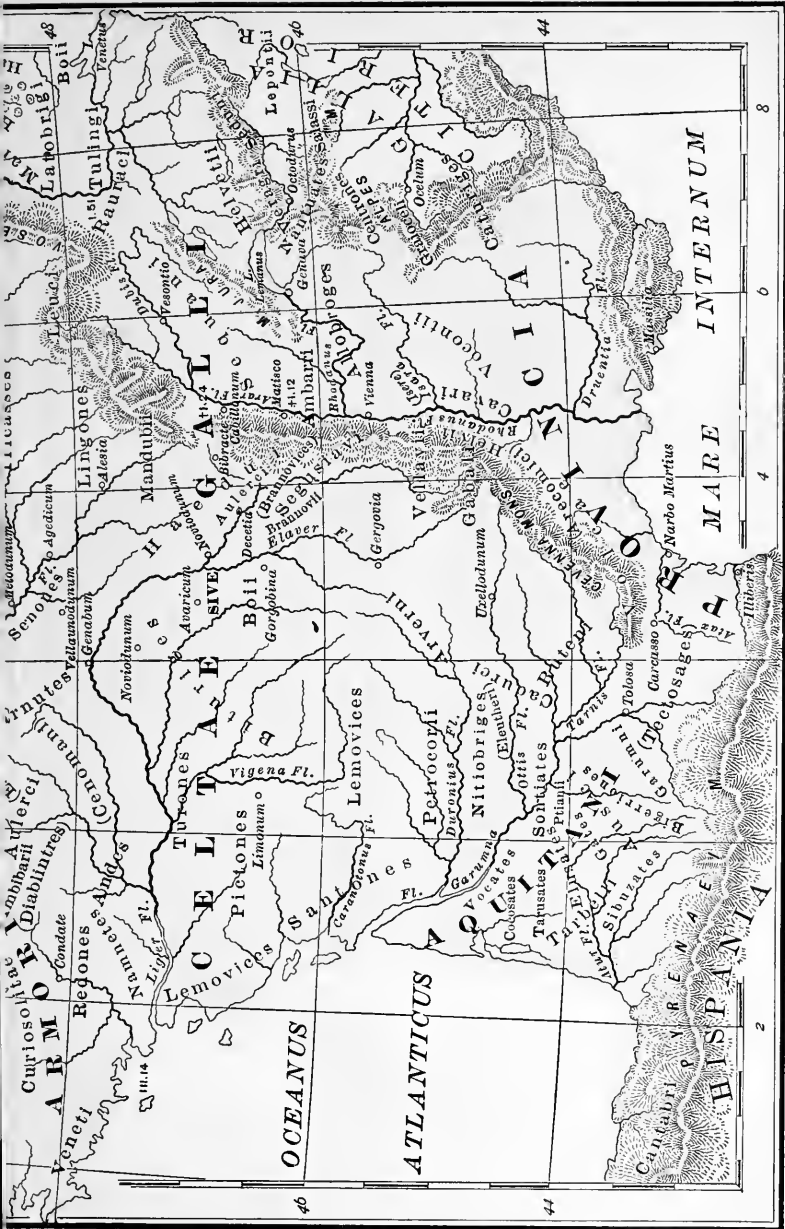



## INTRODUCTION.



### I. — THE LIFE OF CÆSAR.

#### I. *Cæsar's Earlier Career.*

CAIUS JULIUS CÆSAR was born, by the common account, July 12, B.C. 100; or, by a probable reckoning, two years earlier.<sup>1</sup>

He belonged to an ancient patrician family, which claimed descent from Iulus, or Ascanius, the son of Æneas. When "almost a boy," he was made a priest of Jupiter by Marius, his uncle by marriage. When still a youth of eighteen or twenty, he boldly refused to divorce his wife Cornelia, daughter of Cinna, and barely escaped the proscription of Sulla, who "saw many a Marius in that young man."

Though of patrician birth, Cæsar was thus early allied with the popular party, which began to make head directly after the dictator's death. He went through the usual course of political honors to which a Roman of the higher ranks felt himself entitled. At the age of thirty-five, B.C. 67 (assuming the earlier date for his birth), he was Quæstor in Further Spain. Two years later (B.C. 65) he was Curule Ædile, — an office which gave great opportunity to court popular honor, in its charge of

<sup>1</sup> The common date rests on the statement of Plutarch, Suetonius, and Appian that he died at the age of fifty-six. On the other hand: (1) Marius, who died B.C. 86, would hardly have given a priesthood to a child of thirteen; (2) he received the usual honors, by the common reckoning, each two years earlier than the legal age; (3) certain coins struck by him in B.C. 49 have the date LII., apparently the years of his age.

public games and exhibitions.<sup>1</sup> By this time he was recognized as a party leader who would not scruple at the most daring and questionable measures, and was even suspected of having a hand in the schemes of Catiline.

At the age of thirty-nine (B.C. 63) he was elected *pontifex maximus*, — that is, official head of the state religion, — in opposition to the leader of the aristocracy, Quintus Catulus. This was an open declaration of war against the governing aristocracy. Cæsar, it is said, refused a large offer made by Catulus to buy him off the course; and when the day of election came, said to his mother, who would have kept him out of the struggle, “To-day shall see me *pontifex maximus* or an exile.” This office he held for life. The following year (B.C. 62) he was chosen *prætor*, and the next year went, as *proprætor*, to govern the province of Further Spain.

At this period he was chiefly known as a dissolute debtor and demagogue. Before leaving for his province, he was obliged to find security to the amount of eight hundred talents — more than a million dollars. He is reported to have said, in his reckless way, that he wanted four million sesterces to be worth just nothing at all. But in the government of his province he displayed the civil and military ability which afterwards made him famous, as well as the financial ability which enabled him to pay off his debts in one campaign.

He returned to Rome the following year (B.C. 60), and soon formed a political coalition with Pompey and Crassus, his contribution to the common stock being his influence in the political clubs and control of votes. This coalition is sometimes called “the first triumvirate.”<sup>2</sup> One part of the bargain was

<sup>1</sup> In Cæsar’s games “all the equipments, even the cages of the wild beasts, appeared of massive silver; and by a liberality which was all the more princely, that it was based solely on the contraction of debt” (in Latin phrase, “paid by other men’s money”).

<sup>2</sup> The term “triumvirate” means properly a commission or board of three men, invested by law with special powers and functions. This was

that Cæsar should have the consulship for the next year (B.C. 59), and after that the government of Gaul for five years.<sup>1</sup> This embraced the three provinces of *Gallia Narbonensis*, *Gallia Cisalpina* (North Italy), and *Illyricum*. Crassus and Pompey received no special authority at first, but remained in the city, ostensibly as private persons, to look after the interests of the coalition. This was further strengthened by the marriage of Pompey with Cæsar's young and beautiful daughter Julia.

After two successful campaigns in Gaul, in the spring of B.C. 56, Cæsar met his two confederates at Luca, in Etruria, to arrange their future schemes. The conference was held with great display, almost like a royal court. More than two hundred senators were present, and one hundred and twenty lictors were in attendance, attached to the several magistrates. At this conference it was agreed that Pompey and Crassus should hold the consulship the following year, and, after their term of office, should receive by popular vote a similar command to that held by Cæsar, — namely, that Pompey should command in Spain and Crassus in Syria for five years each; also that when Cæsar's five years were up, he should receive in the same way a second term of five years. His ten years' administration would then close at the end of B.C. 49; after which time — an interval the case with the triumvirate of Octavianus (Augustus), Antony, and Lepidus after the death of Cæsar; but this earlier one was only a private knot of political aspirants.

<sup>1</sup> It was a law that both consuls and prætors should have their power (*imperium*) continued for a year after their term of office, and, under the title *proconsul* or *proprator*, govern one of the military provinces. If the proconsul was not relieved at the end of the year, his power continued by the necessity of the case. In one instance, that of Pompey, an extraordinary power was conferred upon the proconsul by act of the people (the Manilian Law). Regularly, however, the assignment of provinces was reckoned a part of the administrative powers of the Senate; and a law of Caius Gracchus directed that the consular provinces should be determined before the election, — that is, a year and a half in advance, — and that then the consuls should draw lots which to have.

of ten years having elapsed—he would be eligible again as consul,

The programme was duly carried out. Crassus departed (B.C. 54) to his province, where he was defeated the next year by the Parthians in the battle of Carrhæ, and shortly after entrapped and killed. Pompey put his province in the hands of one of his subordinates, and remained in the neighborhood of Rome, unwilling to remove from the seat of his personal influence. The death of his wife Julia (B.C. 54) soon sundered the ties which bound him to Cæsar. Jealous from the first, he gradually became openly hostile to him; and at last he found himself leader of the Senate and the aristocracy against Cæsar's revolutionary schemes.

## 2. *Condition of Italy.*

The Roman state was in form and in name a Commonwealth or Republic (*res publica*); but in course of time all political power had come into the hands of a rich landed aristocracy, made up of both "patricians" (*patricii*, men of family) and "plebeians" (*plebeii*, men of the people). The organ of this aristocracy was the Senate, a body ordinarily of six or seven hundred men, who became members of it by holding certain magistracies, from the quæstorship upward, and then kept their seats for life. These magistracies were elective, so that a seat in the Senate rested in theory upon the popular will; but the great houses exercised such controlling influence over the elections through their clients and freedmen, and also by means of the peculiar machinery of election, that it was very difficult for any person not of a noble family (*nobilis*) to be chosen to any office. Opposed to the landed aristocracy was a class of wealthy capitalists known as *equites*, the "Equestrian Order." Many of these were as rich as the senators; but their wealth—most of it gained by usury, state contracts, slave-dealing, and

“farming” of provincial taxes — consisted in money instead of land. A passage in Cicero’s *Cluentius* (ch. 56) speaks of the motives which led young men of that day to renounce the anxious splendor of a political career for the safer pursuit of money-getting. The moneyed aristocracy, accordingly, held aloof from public life, except where it might aid them to obtain rich contracts, or to secure (through the lobby) the passage of some measure that should advance their private interests. There was no industrious middle class in Rome. Manufacture on a large scale, as a means of wealth, was absolutely unknown; while all mechanical industries were carried on by slaves. The poorer class of citizens, the *plebs*, were wholly influenced in their votes by their wealthy patrons or by scheming demagogues.

The rural portions of Italy were for the most part held in large plantations (*latifundia*), owned by nobles, or men of the senatorial order, and cultivated by slaves, or, more frequently, occupied by great droves of cattle tended by herdsmen. This plantation system had crowded out the class of free peasant proprietors in almost all parts of the peninsula. There still remained, however, here and there, especially in Northern Italy (Cisalpine Gaul), a considerable body of small land-owners; and the municipal towns (*municipia*), about four hundred in number, whose territories comprised, politically speaking, the whole area of Italy, were still (as we see in Cicero’s *Roscius*) the home of a fairly prosperous middle-class. The municipal nobility, who had in their hands the government of these towns, were classed with the Equestrian Order: of this important class Cicero himself (a native of Arpinum) is the best-known example. The *equites* of the municipal class, joined with the peasant population where it still survived, formed a considerable body of substantial character and intelligence, who might have served as an opposition party to the corrupt ruler and the aristocracy. But they were too scattered or too distant to exert, as a body, any perceptible influence on public affairs. Since there was no

system of representation, they must go to Rome in person to cast their votes ; and here they were wholly powerless against the hangers-on of the nobles or the turbulent political clubs of the metropolis.

In this class, however, lay whatever hope there was of escape from the corrupt and inefficient rule of the aristocracy. Partisans of the nobility were known as *Optimates* ; those opposed to them, as *Populares*. To the party of the *populares* Cæsar attached himself from his first entrance into public life, notwithstanding he was himself a member of the highest patrician stock ; and, by his remarkable personal qualities as a leader, he succeeded in defeating all the power of the aristocracy in the elections. He appears in his policy to have been powerfully and from conviction influenced by the social and economical necessities of the rural communities and the municipal towns, as is shown by some features of his legislation during the short period of his rule. But the constitution of the Republic was hopelessly inefficient. The governing class was wholly incompetent to its task ; and the only resource against anarchy appears to have been that some one man, by craft or force, should get all the reins of power into his single hand.

For a time, Pompey seemed likely to be this man. Both by military reputation and by personal qualities he might appear to have been well fitted for it ; and a strong personal party — Cicero and Cato among the rest — stayed by him to the last. His sympathies were, on the whole, with the Senate ; and he had neither the energy of political conviction nor the controlling personal ambition to break finally with the traditions of the State. Cæsar had all the qualities, — statesmanlike insight, political ambition, and reckless audacity ; and he put himself at the head of the *populares*, probably with a half-conscious assurance that the end would be to make him master of the Roman world.



## 3. Cæsar's Later Career.

The remainder of Cæsar's life belongs to the general history of Rome. At the close of the Gallic war, the senatorial party required that he should disband his army. This he refused to do, unless Pompey should make an equal surrender of military force. From these demands grew the charge of false play on each side, until the Civil War broke out (B.C. 49), and Pompey fled to Greece, where he was defeated the following year at Pharsalia, and shortly after was murdered in Egypt. Two years later (B.C. 46), in the decisive battle of Thapsus, in Africa, the Republic was finally crushed, and its leader, Cato, put himself to death at Utica. Cæsar now returned to Rome,<sup>1</sup> where he was made *imperator* — possessing the entire *imperium*, or military dominion of Rome, not of a single colony or province merely — and perpetual dictator (*dictator perpetuo*), which offices clothed him with all the political authority of the State. By the powers thus conferred he laid the foundations of the Imperial constitution, which was afterwards (B.C. 30) set in operation by his grand-nephew and adopted son, Octavianus, later known as Augustus. This scheme of government eventually became (as was possibly foreseen from the start) an hereditary monarchy, under the name and form of a republic. During the short period of Cæsar's rule he carried a series of measures of wise and practical statesmanship, such as the reform of the calendar, the regulation of the administrative system, and the policy of checks upon the abuses of the money power; but his possession of this exalted authority aroused the alarm and hate of a fanatic party, who vainly thought to

<sup>1</sup> It is a remarkable illustration of Roman feeling, that, on the day of his triumph, Cæsar, the epicurean rationalist, mounted on his knees the long flight of steps that led up to the Capitol, that by this act of ostentatious humility he might avert those divine judgments supposed to be provoked by inordinate good fortune (*felicitas*).

restore the rule of an effete aristocracy ; and on the Ides of March (March 15), B.C. 44, Julius Cæsar was murdered in the Senate-house by a conspiracy under the pedantic and ungrateful lead of Brutus.

#### 4. *Person and Character of Cæsar.*

In person, Cæsar was tall and slenderly built, his face rather long and thin, his eyes black, vivacious, and keen ("falcon eyes"), his nose prominent, of the Roman type, his head somewhat bald in later life.<sup>1</sup> It might seem certain that he was a man of extraordinary physical as well as mental vigor ; but he was reproached for effeminacy in early life, and is said to have had attacks of epilepsy. "I should have liked," says Michelet, "to see that white and pale countenance, withered before its time by the debauches of Rome ; that delicate and epileptic man, walking at the head of his legions under the rains of Gaul, swimming across its rivers, or riding on horseback among the litters in which his secretaries were borne, and dictating four or six letters at a time ; agitating Rome from the remotest part of Belgium, sweeping away two millions of men on his path, and in the space of ten years subduing Gaul, the Rhine, and the northern ocean."<sup>2</sup> He was a man of varied powers : a student of language, who composed a treatise on grammar while crossing the Alps ; an orator, only second in his generation to

<sup>1</sup> In several of the portraits the character of face reminds one of Henry Clay. That prefixed to this edition, from a bust in the Museum at Naples, is regarded as one of the most authoritative, but as somewhat idealized. An article by Mr. John S. Ropes, in *Scribner's Magazine* for March, 1887, gives engravings of all the best of these portraits. It is interesting, however, to note, as illustrating the wide difference of opinion of many experts on this subject, that Mr. Ropes hardly mentions the Paris bust, which Professor Bernoulli, the highest German authority, considers the most authentic of all.

<sup>2</sup> History of the Roman Republic, Book iii., chap. 5.

Cicero, and, as we can easily believe, of a more sober and masculine style than he. As an historian he has the high qualities of a keen and critical observation, and a style of much condensed vigor; his best ability in this line is shown in the Seventh Book of the *Gallic War*, which is a masterpiece of graphic and energetic narration. The earlier books, while hardly more than a collection of memoranda and military reports, are full of historical information of great interest and value.

## II. — GAUL AND GERMANY.

### I. *The Gallic Province.*

THE district upon whose government Cæsar entered in the spring of B.C. 58, consisted primarily of the two Gallic provinces, Cisalpine and Transalpine. Cisalpine Gaul was the northern portion of Italy, which had been several centuries earlier occupied by invaders from Gaul proper, and was not yet reckoned as politically a part of Italy: it was a wealthy, populous, and orderly country, the proconsul's main dependence for troops and supplies, and his regular winter residence. Transalpine or Narbonnese Gaul received its name from its capital, the Roman colony Narbo. It contained some thriving cities and peaceful districts; but it had as a whole been only recently brought under the authority of Rome, and was still essentially a foreign country. It comprised the whole coast of the Mediterranean, from the Pyrenees to the Alps, its northern boundary being an irregular and uncertain line, separating the conquered nations of Gaul from those which were still free. To these two provinces was attached Illyricum, which was a source of strength, but did not receive much of his attention.

The authority of the governor over his province was that of a military commander, who was not amenable to the laws which protected the citizens of Rome. A few privileged cities

or nations, as the old Greek city Massilia, and the allied tribe of the Ædui (after they were brought within the limits of the empire), were wholly exempted from his authority; but all other parts of the province, even Roman colonies like Narbo, were liable to tribute, and more or less under the jurisdiction of the governor. Each province had its financial officer, or quæstor, who ranked next the governor himself: the commander was likewise attended by staff-officers (*legati*, usually three in number), appointed by the Senate from persons of rank and position; and by an indefinite number of aids (*contubernales* or *comites*), who composed what was sometimes, but incorrectly, called the prætorian cohort. A consular army consisted regularly of two legions (at this time of from 3,000 to 3,600 men); to these were added auxiliaries, both foot and horse, while the governor had power to levy new legions as he required them. Thus we find that Cæsar had six legions in his campaign against the Nervii.

The free territories adjoining a Roman province were in no respect under the authority of the governor; but they were regarded as a legitimate field for his ambition, and there was no lack of pretexts for war. The Roman policy was to enter into friendly relations with one of the parties or tribes in the free territory, load this with favors and privileges, and make use of it to overcome their rivals: in Gaul the Ædui were the favored nation.

Cæsar's province, at its western extremity, touched Spain, a country which had belonged to the empire for more than a hundred and fifty years. North of it lay three great nationalities, with all of which he was brought in contact. These were the Gauls, the Germans, and the Britons.

Free Gaul (*Libera Gallia*) consisted of all the unsubdued territory between the Pyrenees on the one side, and the Rhine and the Alps on the other, thus comprising, in general, modern France and Belgium, with parts of Holland, Germany, and

Switzerland. The central portion of this territory, fully a half in extent and population, was occupied by the Gauls proper, or, as they called themselves, Celts. Southwest of these were the *Aquitani*, of Iberian race, cognate to the Spanish: these are represented by the Basques of the present day. Northeast were the Belgians, whose ethnic affinities are much disputed: all that can be considered certain is that they were largely mixed with Germans. The Belgians occupied more territory than that of the modern Belgium, including a considerable part of Holland, and the northern belt of France.

## 2. *The Gallic State.*

The GAULS were an intellectual and prosperous people, far more civilized than either Germans or Britons. The country, though extensively covered with forests, especially towards the north, was well provided with roads and bridges. The entire population has been reckoned at about seven millions. The people of the Gallic race were tall, fair-complexioned, of restless, sanguine temperament, and addicted to fighting, but skilled in many arts — some portions in weaving; the *Aquitani*, especially, in mining and engineering; and the Bretons (*Veneti*) in open-sea navigation, which they followed with stout, high-built ships, leathern sails, and iron chain-cables. The dress of the Gauls included trousers, and shirts with sleeves; they had a barbaric taste for gaudy ornament; their arms were showy, but clumsy and ineffective beside the tempered weapons of the Romans. They had numerous flourishing cities, which, however, had no political or corporate character like those of Greece and Italy, but were merely places of residence and trade.

The Gauls were not a nation, but a group of nations or tribes, about sixty in number, united by only the slightest bond of consanguinity and common religion. These tribes (which

may be compared to those of the North American Indians, though they were at a much higher degree of civilization) varied greatly in extent and power, the smaller ones often maintaining only a nominal independence under the protection of some larger one. They were for the most part ruled by a turbulent and oppressive aristocracy, sometimes with an elected chief magistrate, while sometimes an ambitious leader, like Orgetorix, succeeded in establishing for a time a kingly power. Thus the several states were torn by hostile parties, and were at the same time grouped into national factions, under the lead of the more powerful states, like the *Ædui*, *Arverni*, and *Remi*. Of these factions, at the time of Cæsar's invasion, the *Ædui* were at the head of one which sought to gain supremacy by entering into alliance with the Romans. Their nearest neighbors and antagonists, the *Sequani*, had naturally looked in the opposite direction for allies, and found them in the Germans.

The Britons were, like the Gauls, of Celtic race, and resembled them in every respect, except that, being further from the civilized world, they were ruder, freer, and more warlike.

It was the destiny of Julius Cæsar to bring the great Gallic people into the system of civilization and government represented by Rome: it was a definite and large extension of the bounds of civilized society. From him, too, we have the earliest authentic accounts of the other two nationalities,—the Germans and the Britons.

### 3. *Germany.*

The GERMANS occupied nearly the same territory as at the present day, — not so far west as now, but, on the other hand, extending farther to the east. Less advanced in civilization than the Gauls, they were still far from being savages. They appear to have been just emerging from what is known as the barbarous state, — beginning to acquire fixed habitations, and

to cultivate the ground : they had no cities. They had brought with them from their migrations a political system — similar in origin to that of the Gallic tribes — based upon an original community of descent, in which the patriarchal organization had already expanded into a multitude of petty nations, grouped into larger combinations of race. Their institutions, unlike those of the Gauls, were democratic ; they had noble families, but these possessed no political prerogatives. Some nations had kings ; but these were only a higher grade of magistrates, possessing no despotic or controlling authority. We find, however, among the Germans, the germ of the later feudal aristocracy, in the practice of their chiefs to surround themselves with a body of personal followers or retainers, whom they employed in war and maintained in peace.

Various considerations, says a recent writer, make it probable “that the Germans had come down from the northeast not very long before the Christian era, and intruded themselves, as a wedge, between those two more anciently recorded nations (Scythians and Celts). . . . We shall see evidence of the continuous advance of a civilized race from the confines of India to these islands, and nothing indicative of a great rush from the North of wild hordes bent upon robbery and destruction, as it has been usually represented to have been. The gradual drying of the Caspian Sea left the interior of Asia more and more barren ; the knowledge of the useful metals facilitated the conquest of the savages of the West ; and predatory bands of Huns and Turks, and allied nomadic nations, are likely to have accelerated the movement by rendering the labors of agriculture less remunerative. Thus the migration, being one that proceeded from constantly acting causes, extended over many centuries. . . .

“In these mere names [of plants and fruits], setting aside all other sources of information, we discover that these people came from their home in the East with a knowledge of letters

and the useful metals, and with nearly all the domestic animals ; that they cultivated oats, barley, wheat, rye, and beans ; built houses of timber, and thatched them ; and, what is important as showing that their pasture and arable land was intermixed, and acknowledged as private property, they hedged their fields and fenced their gardens. Cæsar denies this ; but the frontier tribes, with whom he was acquainted, were living under certain peculiar Mark laws, and were, in fact, little else than an army on its march. The unquestionably native, and not Latin or Celtic, origin of such names as Beach and Hawthorn, of Oats and Wheat, prove that although our ancestry may have been indebted to the provincials of the empire for their fruit-trees and some other luxuries, for a knowledge of the fine arts, and the Latin literature, and a debased Christianity, the more essential acquirements, upon which their prosperity and progress as a nation depended, were already in their possession." — PRIOR, *Popular Names of British Plants*. Introd. (1863).<sup>1</sup>

<sup>1</sup> The account here given of the civilization and social condition of the Germans is graphic and correct in its main features, and we have thought it best to cite it in full. It ought to be noted, however, that the description of their agriculture and landed institutions is not in accordance with the presently received opinions. There is no ground for disparaging or doubting the testimony of Cæsar and Tacitus, whose statements confirm one another and are confirmed by all that we can gather from other sources of information. The Germans were now passing from their migratory or semi-nomadic condition into that of settled habitations and regular industry, but they had not yet completed the transition. There was, as Cæsar informs us, no individual ownership of land among them, and it is doubtful whether there was such even in the times of Tacitus, one hundred and fifty years later. The events narrated in the last half of the first book form an important epoch in the history of civilization. The occupation of the Sequanian territory by Ariovistus was the last step forward in their migration ; and to Cæsar belongs the credit of having put a final and decisive check upon this movement, and confined them within the limits of the Rhine. Fifty years before this, the Cimbri and Teutones had invaded the empire and excited great terror and consternation ; but their invasion was



4. *The Campaigns in Gaul.*

The campaigns of Cæsar in Gaul lasted through eight seasons (B.C. 58-51), and are told in eight books, — the last written by Hirtius, an officer of Cæsar, — each book containing the operations of a single year. The following is a brief outline : —

I. Cæsar checks the attempt of the Helvetians to colonize in Western Gaul, and forces them, after a bloody defeat, to return to their own territory. He then engages with a powerful tribe of Germans, who had made a military settlement in Eastern Gaul, and drives them, with their chief, Ariovistus, beyond the Rhine.

II. A formidable confederacy of the northern populations of Gaul is suppressed, with the almost complete extermination of the bravest Belgian tribe, the *Nervii*, in a battle which seems to have been one of the most desperate of all Cæsar ever fought. In this campaign the coast towns of the west and northwest (Brittany) are reduced to submission.

III. After a brief conflict with the mountaineers of the Alps, who attacked the Roman armies on their march, the chief operations are the conquest of the coast tribes of Brittany (*Veneti*, etc.), in a warfare of curious naval engineering in the shallow tide-water inlets and among the rocky shores. During the season, the tribes of the southwest (*Aquitani*), a mining population, allied to the Iberians or Basques, are reduced by one of Cæsar's officers.

IV. An attack from the Germans on Northern Gaul is repulsed ; and Cæsar follows them, by a bridge of timber hastily built, across the Rhine. Returning, he crosses to Britain in the early autumn for a visit of exploration.

a predatory raid, permanently ended when they were defeated by Marius. Ariovistus, on the other hand, was the leader of a colonizing movement, like that of Hengist and Horsa on the shores of Britain.

V. The partial conquest of Britain (second invasion) is followed by various movements in Northern Gaul, in which the desperate condition of the Roman garrisons is relieved by the prudent and brave conduct of Labienus and Quintus Cicero.

VI. Cæsar makes a brief expedition across the Rhine, against the Germans. Some general disturbances are quelled, and Northern Gaul is reduced to peace.

VII. Vercingetorix, a brave and high-spirited chief of Southern Gaul, effects a confederacy of the whole country, which is at length subdued. Vercingetorix, in brilliant equipment, surrenders himself to secure the quiet of the country, and is taken in chains to Rome, where he is afterwards put to death in Cæsar's triumph.

VIII. Slight insurrections, breaking out here and there, are easily subdued; and by the capture of the last native stronghold, Uxellodunum, the subjugation of Gaul is made complete.

NOTE.—The following, taken from notes of a summer excursion made by one of the editors of this volume, may help the young student to conceive a little more distinctly one of the earlier scenes of these celebrated campaigns.

### DID CÆSAR FORTIFY THE RHONE ?

SOME years ago, having occasion to look at the matter, I was struck to find that in the *Life of Cæsar* by Napoleon III., reports of engineers were given, to the effect that only a few points here and there in those nineteen miles needed fortification, or probably ever were fortified; and those same engineers reported that they had found traces, at such points, of what they supposed to be Cæsar's forts. This may have been because they looked for them there; and perhaps if they had looked for something else, they would have found that too.

At least my curiosity was moved, and I thought to myself that if I ever had the chance I would look with my own eyes and see what I could see. Now it happened, in the summer of 1881, that I spent a few days at Geneva, and on the third day proceeded to put my scheme in practice. In the morning I went by omnibus over the five dusty miles to Ferney, to see Voltaire's estate and chapel there; and from this elevation had a splendid view not only of the Mont-Blanc range to the southeast, but of the slope of the Jura, as plain as it is on the map, toward the Rhone and the southwest. At noon I was back in Geneva, and spent the afternoon in following the parched, rough, and dusty margin of the river as far down as I could conveniently go. A good deal of the way was through a rather scrubby growth of trees, and some of it over rough field cracked with the heat and drought of early August. I kept, as nearly as I could, the line which must have been followed by Cæsar's engineers, and may fairly say that I stood on every "coigne of vantage" that commanded a fair view of the river for at least five miles below Geneva.

As to the remaining dozen or fifteen miles, I of course do not pretend to say. But the general impression I took from the survey I did make might be summed up by saying that General Scott might as well have claimed, for political effect, to have fortified the gorge

below Niagara against the Canadians in the War of 1812. At Geneva, as everybody knows, the river rushes out of the lake in great body and force. Byron calls it "the arrowy Rhone," which the guide-book improves upon by saying that it flows "swift as an arrow." Some allowance must be made for this poetic but violent hyperbole. But it is no exaggeration at all to say that the Rhone, as it passes under and issues from the bridges at Geneva, is a gigantic mill-race. At its narrowest it is about four hundred feet wide (by my reckoning), and though it widens out a good deal below, it seems to abate nothing of its speed. The Arve comes in, a mile or so below the city, and its white-brown, clayey water spins along on the surface of the torrent, showing hardly any sign of mingling as far as I could follow it with my eye.

To all appearance it would be perfectly idle to float a boat in the current. Not a sign of a boat was anywhere to be seen, except where here and there some craft was moored to the shore, so as to take advantage of the stream to turn a mill-wheel, — possibly, too, to catch fish, or wash clothes. As for navigation, it seemed ridiculous to hint at any such thing. Yet just here, the river being perhaps half a mile wide, — or a few miles below, where it is wider yet and about as swift, — we are to believe that the unfortunate Helvetians made a serious attempt to cross in their pitiful canoes, and it is something of a victory for Cæsar's troops to have prevented their landing! If they did try, it would be hard to persuade me that they ever got half way over, or that the victory was anything more than the fun of seeing them swept helpless down the stream.

I am, further, very sceptical as to their ever reaching the water's edge on the other side. All the way along, on both sides, there are precipitous banks, coming close down into the river, which I roughly guessed to be (on the opposite side) about a hundred feet high. The *cabarétier* on the hither bank, where I got my humble repast, thought they were full three hundred. Either height is quite enough to make any such attempt impossible. In order to give the proportions of his victory, Cæsar tells us, afterwards, that the armed migration of the Helvetians consisted of more than 368,000, — men, women, and children, to say nothing of wagons and live-stock. And only a sharp fight prevents these poor creatures, — after they have climbed down that precipice and got somehow to the water's

edge, — from forcing a landing on the other bank, equally high, steep, and barricaded with trees! Where did the fleet of boats come from? And how was that multitude, cattle, carts, and all, to get across that half-mile mill-race? I ought to say that there is not even a respectable wall of rock to climb down by, but (so far as one can judge) a sort of indurated clay, — not slaty shale, like that at Niagara, which you can crumble off in your fingers, but lumpy, amorphous, and (one would think) the most treacherous climbing in the world.

I do not believe that Cæsar would have made his — real or imaginary — wall extend all the way from Geneva, as he did, if he had not been at a safe distance from Rome. With all his great qualities as a military leader, he was at the same time a shrewd politician, watching his chances at home when the war of conquest should be over. His notes of battle and march were hastily made up, in little packages, and sent to his friends at the capital, as powder for the campaign going on there. They were written for political effect; and I do not see why we should take them at their word, any more than other things written for political effect. At least in this part of the ground, I think the story is very suspicious. I dare say there may have been fortified spots here and there along the bank, as the French engineers assert, — probably for purposes of observation, not defence. But as to this “wall nineteen miles long and sixteen feet high, with a ditch,” I conclude that we may take as much or as little of it as we choose.

## CENTURY OF CIVIL WARS IN ROME.

---

B.C.

133. Tribune and death of TIBERIUS GRACCHUS.  
 123. Tribune of CAIUS GRACCHUS; 121. His death.  
 111-106. War with Jugurtha: MARIUS and SULLA.  
 107, 104-100. Six consulships of Marius.  
 102, 101. Defeat of *Teutones* and *Cimbri* by Marius.  
 90-88. War with Italian Allies (*Social War*).  
 88, 81: 74-63. Wars with *Mithridates*.  
 88-82. CIVIL WAR: — 88. Sulla in Rome; flight of Marius. 87. Massacres of Marius and Cinna. 86. Seventh consulship and death of Marius. 82. Proscriptions and legislation of Sulla (Dictator, 81; his death, 78).  
 83-72. War with SERTORIUS in Spain.  
 73-71. *Servile War* (with Spartacus), ended by Crassus.  
 70. POMPEY and CRASSUS, Consuls; Sulla's legislation repealed.  
 67. War with *Pirates* ended by Pompey; CÆSAR, Quæstor in Spain (Curule Ædile, 65; Prætor, 62).  
 66. Pompey made Commander in the East (*Manilian Law*).  
 63. CICERO, Consul: Catiline's Conspiracy suppressed; Cæsar, *Pontifex Maximus*; Pro-prætor in Spain, 61.  
 60. FIRST TRIUMVIRATE: coalition of Cæsar, Pompey, and Crassus (lasts till 54).  
 59. Cæsar, Consul: Agrarian and Corn Laws.  
 58-50. CAMPAIGNS IN GAUL: — 58. Defeat of Helvetians and Germans. 57. Destruction of *Nervii*. 56. Defeat of *Veneti* and *Aquitani*. 55. Passage into Germany and Britain. 54. Second invasion of Britain; risings in Northern Gaul. 53. Second passage into Germany. 52. War of *Vercingetorix*. 51. Southern Gaul reduced. 50. Civil order restored.  
 54. Parthian War: death of Crassus (53).  
 50. Cicero, Proconsul in Cilicia (returns to Italy in October).  
 49-45. CIVIL WAR: — 49. Cæsar in Italy and Spain. 48. Battle of *Pharsalus*; death of Pompey. 47. Defeat of *Pharnaces*; Cæsar Dictator. 46. African War: *Thapsus*; death of Cato. 45. Defeat of Sex. Pompey in Spain: *Munda*; Reforms of Cæsar as PERPETUAL DICTATOR. 44. Cæsar murdered in the Senate-House. 43. Proscriptions of TRIUMVIRATE (Antony, Octavianus, and Lepidus); death of Cicero. 42. Battle of *Philippi*: death of Brutus and Cassius.  
 31. Battle of *Actium*: Octavianus (AUGUSTUS) sole Lord of the Roman World.







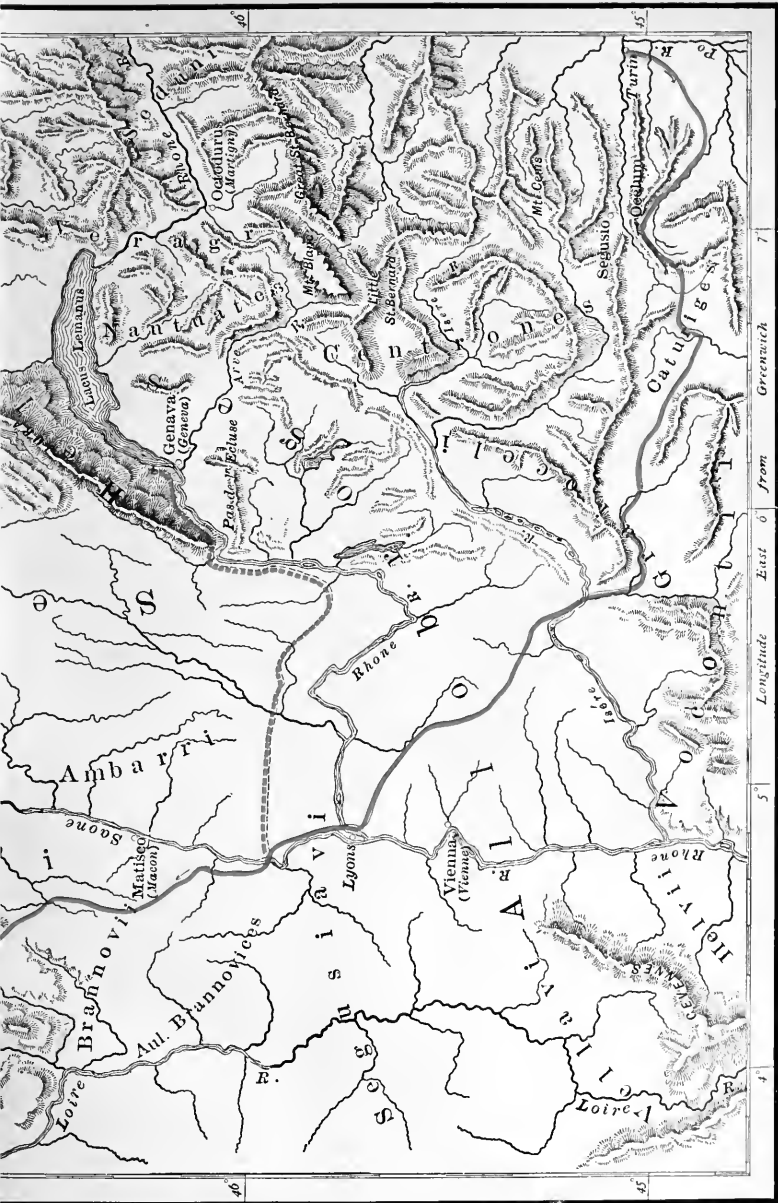



# THE GALLIC WAR.

## BOOK I.

INTRODUCTION: Description of Gaul (Chap 1).

THE HELVETIAN WAR.— Orgetorix, an Helvetian chief, plans the invasion of Gaul: he conspires with the chiefs of several Gallic tribes; is brought to trial, escapes, and is put under the ban; soon afterwards dies (2-4). The Helvetians complete their preparations, and gather near the Rhone, requesting leave to pass peaceably through the Province. Cæsar delays them by pretexts, while he hastily throws up an earthwork to prevent their crossing the river. They attempt the passage, but are repulsed (5-8). Forming a league with the Sequani, they penetrate and ravage the territory of the Ædui, friends of Rome, who solicit protection. Cæsar, levying a force of upwards of 30,000, overtakes and cuts to pieces their rear-guard (*Tigurini*), at the crossing of the Arar (9-12). An embassy of the Helvetians, headed by the aged Divico, leads to no result. A cavalry skirmish, in which the Romans are worsted, together with the delay of supplies, shows the bad faith of a party among the Ædui, headed by Dumnorix; who is arrested, but spared on the intercession of his brother Divitiacus, and put under close guard by Cæsar (13-20). Cæsar makes preparations for attack, but is prevented by a false alarm, and moves towards Bibracte. The Helvetians, now well in advance, turn about for battle. They are forced to retreat to a hill, and attempt to flank the Romans; but are completely routed, and fly towards the north (21-26). They are at length forced to surrender. Six thousand escape, but are retaken, and put to death. The remainder are compelled to return to Helvetia, and rebuild the villages which they had destroyed (27-29).

THE WAR WITH ARIOVISTUS.— The chief populations of Gaul seek terms of amity, representing the condition of the country, especially under the invasions of the German Ariovistus, by whom the Sequani are chiefly oppressed (30-33). Cæsar sends envoys

to him, but receiving a haughty reply sets out on a forced march towards the German frontier (34-38). His men are greatly terrified, but are cheered by his assurances, especially of reliance on the tenth legion (39-41). At the request of Ariovistus, a conference is held, but is broken up by signs of bad faith among the Germans (42-46). A second conference, proposed by Ariovistus, is refused, and he throws into chains the messengers sent by Cæsar. After a cavalry skirmish, an indecisive battle follows, and the Germans fall back to their camp (47-50). Cæsar attacks the camp: the Germans, marshalled by tribes, defend their families and equipage. A close and furious engagement follows, in which the Germans are routed and driven to the Rhine. Ariovistus escapes, a part of his household is taken, and Cæsar returns to his winter quarters (51-54).

GALLIA est omnis divisa in partes tres; quarum unam incolunt Belgae, aliam Aquitani, tertiam qui ipsorum lingua Celtae, nostra Galli appellantur. Hi omnes lingua, institutis, legibus inter se differunt. Gallos ab Aquitanis Garumna flumen, a Belgis Matrona et Sequana dividit. <sup>2</sup>Horum omnium fortissimi sunt Belgae, propterea quod a cultu atque humanitate provinciae longissime absunt, minimeque ad eos mercatores saepe comitant, atque ea quae ad effeminandos animos pertinent important; proximique sunt Germanis, qui trans Rhenum incolunt, quibuscum continenter bellum gerunt. <sup>3</sup>Qua de causa Helvetii quoque reliquos Gallos virtute praecedunt, quod fere quotidianis proeliis cum Germanis contendunt, cum aut suis finibus eos prohibent, aut ipsi in eorum finibus bellum gerunt. <sup>4</sup>Eorum una pars, quam Gallos obtinere dictum est, initium capit a flumine Rhodano; continetur Garumna flumine, Oceano, finibus Belgarum; attingit etiam ab Sequanis et Helvetiis flumen Rhenum; vergit ad septentriones. <sup>5</sup>Belgae ab extremis Galliae finibus oriuntur, pertinent ad inferiorem partem fluminis Rheni, spectant in septentrionem et orientem solem. Aquitania a Garumna flumine ad Pyrenaeos

montes et eam partem Oceani quae est ad Hispaniam pertinet, spectat inter occasum solis et septentriones.

2. Apud Helvetios longe nobilissimus fuit et ditissimus Orgetorix. Is, M. Messala et M. Pisone consulibus, regni cupiditate inductus, conjurationem nobilitatis fecit, et civitati persuasit ut de finibus suis cum omnibus copiis exirent: perfacile esse, cum virtute omnibus praestarent, totius Galliae imperio potiri. <sup>2</sup>Id hoc facilius eis persuasit, quod undique loci natura Helvetii continentur: una ex parte flumine Rheno latissimo <sup>10</sup> atque altissimo, qui agrum Helvetium a Germanis dividit; altera ex parte monte Jura altissimo, qui est inter Sequanos et Helvetios; tertia lacu Lemanno et flumine Rhodano, qui provinciam nostram ab Helvetiis dividit. <sup>3</sup>His rebus fiebat, ut et minus late <sup>15</sup> vagarentur, et minus facile finitimis bellum inferre possent; qua ex parte homines bellandi cupidi magno dolore adficiebantur. <sup>4</sup>Pro multitudine autem hominum, et pro gloria belli atque fortitudinis, angustos se fines habere arbitrabantur, qui in longitudinem milia <sup>20</sup> passuum CCXL, in latitudinem CLXXX patebant.

3. His rebus adducti, et auctoritate Orgetorigis permoti, constituerunt ea quae ad proficiscendum pertinerent comparare, jumentorum et carrorum quam maximum numerum coëmere, sementes quam maxi- <sup>25</sup> mas facere, ut in itinere copia frumenti suppeteret, cum proximis civitatibus pacem et amicitiam confirmare. <sup>2</sup>Ad eas res conficiendas biennium sibi satis esse duxerunt, in tertium annum profectionem lege confirmant. Ad eas res conficiendas Orgetorix deli- <sup>30</sup> gitur. <sup>3</sup>Is sibi legationem ad civitates suscepit. In eo itinere persuadet Castico, Catamantaloedis filio, Sequano, cujus pater regnum in Sequanis multos annos obtinuerat, et a senatu populi Romani amicus appellatus erat, ut regnum in civitate sua occuparet, quod <sup>35</sup> pater ante habuerat; itemque Dumnorigi Haeduo,

fratri Divitiaci, qui eo tempore principatum in civitate obtinebat ac maxime plebi acceptus erat, ut idem conaretur persuadet, eique filiam suam in matrimonium dat. <sup>4</sup>Perfacile factu esse illis probat conata perficere,   
 5 propterea quod ipse suae civitatis imperium obtenturus esset: non esse dubium, quin totius Galliae plurimum Helvetii possent; se suis copiis suoque exercitu illis regna conciliaturum confirmat. <sup>5</sup>Hac oratione adducti, inter se fidem et jusjurandum dant, et, regno occupato, per tres potentissimos ac firmissimos populos totius Galliae sese potiri posse sperant.

4. Ea res est Helvetiis per indicium enuntiata. Moribus suis Orgetorigem ex vinculis causam dicere coegerunt. Damnatum poenam sequi oportebat, ut   
 15 igni cremaretur. <sup>2</sup>Die constituta causae dictionis, Orgetorix ad iudicium omnem suam familiam, ad hominum milia decem, undique coegit, et omnes clientes obaeratosque suos, quorum magnum numerum habebat, eodem conduxit; per eos, ne causam diceret,   
 20 se eripuit. <sup>3</sup>Cum civitas ob eam rem incitata armis jus suum exsequi conaretur, multitudinemque hominum ex agris magistratus cogerent, Orgetorix mortuus est; neque abest suspitio, ut Helvetii arbitrantur, quin ipse sibi mortem consciverit.

5. Post ejus mortem, nihilo minus Helvetii id quod constituerant facere conantur, ut e finibus suis exeant. Ubi jam se ad eam rem paratos esse arbitrati sunt, oppida sua omnia numero ad duodecim, vicos ad   
 30 quadringentos, reliqua privata aedificia incendunt; frumentum omne, praeterquam quod secum portaturi erant, comburunt, ut — domum reditionis spe sublata — paratiores ad omnia pericula subeunda essent; trium mensium molita cibaria sibi quemque domo efferre jubent. <sup>2</sup>Persuadent Rauracis et Tulingis et Latobrigis   
 35 finitimis, uti, eodem usi consilio, oppidis suis vicisque exustis, una cum iis proficiscantur; Boiosque, qui

trans Rhenum incoluerant, et in agrum Noricum transierant Noreiamque oppugnarant, receptos ad se socios sibi adsciscunt.

6. Erant omnino itinera duo, quibus itineribus domo exire possent: unum per Sequanos, angustum et difficile, inter montem Juram et flumen Rhodanum, vix qua singuli carri ducerentur; mons autem altissimus impendebat, ut facile perpauci prohibere possent: <sup>2</sup>alterum per provinciam nostram, multo facilius atque expeditius, propterea quod inter fines Helvetiorum et Allobrogum, qui nuper pacati erant, Rhodanus fluit, isque nonnullis locis vado transitur. Extremum oppidum Allobrogum est, proximumque Helvetiorum finibus, Genua. <sup>3</sup>Ex eo oppido pons ad Helvetios pertinet. Allobrogibus sese vel persuasuros (quod nondum bono animo in populum Romanum viderentur) existimabant, vel vi coacturos, ut per suos fines eos ire pate-  
rentur. <sup>4</sup>Omnibus rebus ad profectionem comparatis, diem dicunt, qua die ad ripam Rhodani omnes conveniant. Is dies erat a. d. v. Kal. Apr., L. Pisone A. Gabinio consulibus.

7. Caesari cum id nuntiatum esset, eos per provinciam nostram iter facere conari, maturat ab urbe proficisci, et quam maximis potest itineribus in Galliam ulteriorem contendit, et ad Genuam pervenit. <sup>2</sup>Provinciae toti quam maximum potest militum numerum imperat — erat omnino in Gallia ulteriore legio una; pontem, qui erat ad Genuam, jubet rescindi. <sup>3</sup>Ubi de ejus adventu Helvetii certiores facti sunt, legatos ad eum mittunt, nobilissimos civitatis, cujus legationis Nammeius et Verudoctius principem locum obtinebant, qui dicerent 'sibi esse in animo sine ullo maleficio iter per provinciam facere, propterea quod aliud iter haberent nullum: rogare, ut ejus voluntate id sibi facere liceat.' <sup>4</sup>Caesar, quod memoria tenebat L. Cassium consulem occisum, exercitumque ejus ab Hel-

vetiis pulsum et sub jugum missum, concedendum non putabat; neque homines inimico animo, data facultate per provinciam itineris faciundi, temperaturos ab injuria et maleficio existimabat. <sup>5</sup>Tamen, ut spatium  
5 intercedere posset, dum milites quos imperaverat convenirent, legatis respondit diem se ad deliberandum sumpturum; si quid vellent, ad Id. Apr. reverterentur.

8. Interea ea legione, quam secum habebat, militibusque qui ex provincia convenerant, a lacu Lemanno,  
10 qui in flumen Rhodanum influit, ad montem Juram, qui fines Sequanorum ab Helvetiis dividit, milia passuum decem novem, murum in altitudinem pedum sedecim, fossamque perducit. <sup>2</sup>Eo opere perfecto, praesidia disponit, castella communit, quo facilius, si  
15 se invito transire conarentur, prohibere possit. <sup>3</sup>Ubi ca dies quam constituerat cum legatis venit, et legati ad eum reverterunt, negat se more et exemplo populi Romani posse iter ulli per provinciam dare; et, si vim facere conentur, prohibiturum ostendit. <sup>4</sup>Helvetii, ea  
20 spe dejecti, navibus junctis ratibusque compluribus factis, alii vadis Rhodani, qua minima altitudo fluminis erat, nonnunquam interdium, saepius noctu, si percurrere possent conati, operis munitione et militum concursu et telis repulsi, hoc conatu destiterunt.

25 9. Relinquebatur una per Sequanos via, qua, Sequanis invitis, propter angustias ire non poterant. His cum sua sponte persuadere non possent, legatos ad Dumnorigem Haeduum mittunt, ut eo deprecatore a Sequanis impetrarent. <sup>2</sup>Dumnorix gratia et largitione  
30 apud Sequanos plurimum poterat, et Helvetiis erat amicus, quod ex ea civitate Orgetorigis filiam in matrimonium duxerat; et cupiditate regni adductus novis rebus studebat, et quam plurimas civitates suo beneficio habere obstrictas volebat. <sup>3</sup>Itaque rem suscipit, et  
35 a Sequanis impetrat ut per fines suos Helvetios ire patiantur, obsidesque uti inter sese dent perficit: Se-



quani, ne itinere Helvetios prohibeant; Helvetii, ut sine maleficio et injuria transeant.

10. Cæsari renuntiatur Helvetiis esse in animo per agrum Sequanorum et Haeduorum iter in Santonum fines facere, qui non longe a Tolosatium finibus ab- 5 sunt, quae civitas est in Provincia. <sup>2</sup>Id si fieret, intellegebat magno cum periculo provinciae futurum, ut homines bellicosos, populi Romani inimicos, locis patentibus maximeque frumentariis finitimos haberet. <sup>3</sup>Ob eas causas, ei munitioni quam fecerat T. Labie- 10 num legatum praefecit; ipse in Italiam magnis itineribus contendit, duasque ibi legiones conscribit, et tres, quae circum Aquileiam hiemabant, ex hibernis educit, et, qua proximum iter in ulteriorem Galliam per Alpes erat, cum his quinque legionibus ire contendit. <sup>4</sup>Ibi 15 Centrones et Graioceli et Caturiges, locis superioribus occupatis, itinere exercitum prohibere conantur. Compluribus his proeliis pulsus, ab Ocelo, quod est citerioris provinciae extremum, in fines Vocontiorum ulterioris provinciae die septimo pervenit; inde in 20 Allobrogum fines, ab Allobrogibus in Segusiavos exercitum ducit. Hi sunt extra provinciam trans Rhodanum primi.

11. Helvetii jam per angustias et fines Sequanorum suas copias traduxerant, et in Haeduorum fines per- 25 venerant, eorumque agros populabantur. Haedui, cum se suaque ab iis defendere non possent, legatos ad Cæsarem mittunt rogatum auxilium: <sup>2</sup>'Ita se omni tempore de populo Romano meritos esse, ut paene in conspectu exercitus nostri agri vastari, liberi eorum 30 in servitutem abduci, oppida expugnari non debuerint.'<sup>3</sup>Eodem tempore Haedui Ambarri, necessarii et consanguinei Haeduorum, Cæsarem certiolem faciunt, sese, depopulatis agris, non facile ab oppidis vim hostium prohibere. <sup>4</sup>Item Allobroges, qui trans Rhoda- 35 num vicos possessionesque habebant, fuga sc ad

Caesarem recipiunt, et demonstrant sibi praeter agri solum nihil esse reliqui. <sup>5</sup> Quibus rebus adductus, Caesar non exspectandum sibi statuit, dum, omnibus fortunis sociorum consumptis, in Santonos Helvetii pervenirent.

12. Flumen est Arar, quod per fines Haeduorum et Sequanorum in Rhodanum influit, incredibili lenitate, ita ut oculis, in utram partem fluat, judicari non possit. Id Helvetii ratibus ac lincibus junctis transibant. <sup>2</sup> Ubi per exploratores Caesar certior factus est, tres jam partes copiarum Helvetios id flumen traduxisse, quartam fere partem citra flumen Ararim reliquam esse; de tertia vigilia cum legionibus tribus e castris profectus, ad eam partem pervenit, quae nondum flumen transierat. <sup>3</sup> Eos impeditos et inopinantes adgressus, magnam partem eorum concidit: reliqui sese fugae mandarunt, atque in proximas silvas abdiderunt. Is pagus appellabatur *Tigurinus*: nam omnis civitas Helvetia in quattuor pagos divisa est. <sup>4</sup> Hic pagus unus, cum domo exisset, patrum nostrorum memoria L. Cassium consulem interfecerat, et ejus exercitum sub jugum miserat. Ita sive casu, sive consilio deorum immortalium, quae pars civitatis Helvetiae insignem calamitatem populo Romano intulerat, ea princeps poenas persolvit. <sup>5</sup> Qua in re Caesar non solum publicas, sed etiam privatas injurias ultus est; quod ejus soceri L. Pisonis avum, L. Pisonem legatum, Tigurini eodem proelio quo Cassium interfecerant.

13. Hoc proelio facto, reliquas copias Helvetiorum ut consequi posset, pontem in Arare faciendum curat, atque ita exercitum traducit. <sup>2</sup> Helvetii, repentino ejus adventu commoti, cum id quod ipsi diebus xx aegerrime confecerant, ut flumen transirent, illum uno die fecisse intellegerent, legatos ad eum mittunt; <sup>3</sup> cujus legationis Divico princeps fuit, qui bello Cassiano dux Helvetiorum fuerat. <sup>3</sup> Is ita cum Caesare egit:

Si pacem populus Romanus cum Helvetiis faceret, in eam partem ituros atque ibi futuros Helvetios, ubi eos Caesar constituisset atque esse voluisset; sin bello persequi perseveraret, reminisceretur et veteris incommodi populi Romani, et pristinae virtutis Helvetiorum. 5  
<sup>4</sup>Quod improvise unum pagum adortus esset, cum ii, qui flumen transissent, suis auxilium ferre non possent, ne ob eam rem aut suae magnopere virtuti tribueret, aut ipsos despiceret; se ita a patribus majoribusque suis didicisse, ut magis virtute quam dolo contenderent, aut insidiis niterentur. <sup>5</sup>Quare ne committeret, ut is locus, ubi constitissent, ex calamitate populi Romani et interneccione exercitus nomen caperet, aut memoriam proderet.'

14. His Caesar ita respondit: 'Eo sibi minus dubitationis dari, quod eas res, quas legati Helvetii commemorassent, memoria teneret, atque eo gravius ferre, quo minus merito populi Romani accidissent: <sup>2</sup>qui si alicujus injuriae sibi conscius fuisset, non fuisse difficile cavere; sed eo deceptum, quod neque commissum a se intellexeret quare timeret, neque sine causa timendum putaret. <sup>3</sup>Quod si veteris contumeliae oblivisci vellet, num etiam recentium injuriarum, quod eo invito iter per provinciam per vim temptassent, quod Haeduos, quod Ambarros, quod Allobrogas vexassent, <sup>25</sup>memoriam deponere posse? <sup>4</sup>Quod sua victoria tam insolenter gloriarentur, quodque tam diu se impune injurias tulisse admirarentur, eodem pertinere. <sup>5</sup>Consuesse enim deos immortales, quo gravius homines ex commutatione rerum doleant, quos pro scelere eorum <sup>30</sup>ulcisci velint, his secundiore interdum res et diuturniorem impunitatem concedere. <sup>6</sup>Cum ea ita sint, tamen si obsides ab iis sibi dentur, uti ea quae polliceantur facturos intellegat, et si Haeduis de injuriis quas ipsis sociisque eorum intulerint, item si Allobrogibus satisfaciant, sese cum iis pacem esse facturum.' <sup>7</sup>Divico

respondit: 'Ita Helvetios a majoribus suis institutos esse, uti obsides accipere, non dare consuerint; ejus rei populum Romanum esse testem.' Hoc responso dato, discessit.

5 15. Postero die castra ex eo loco movent. Idem facit Caesar, equitatumque omnem, ad numerum quattuor milium, quem ex omni provincia et Haeduis atque eorum sociis coactum habebat, praemittit, qui videant quas in partes hostes iter faciant. <sup>2</sup> Qui, cupi-

10 dius novissimum agmen insecuti, alieno loco cum equitatu Helvetiorum proelium committunt; et pauci de nostris cadunt. <sup>3</sup> Quo proelio sublatis Helvetii, quod quingentis equitibus tantam multitudinem equitum propulerant, audacius subsistere nonnunquam, et

15 novissimo agmine proelio nostros lacessere coeperunt. <sup>4</sup> Caesar suos a proelio continebat, ac satis habebat in praesentia hostem rapinis, pabulationibus, populationibusque prohibere. <sup>5</sup> Ita dies circiter quindecim iter fecerunt, uti inter novissimum hostium agmen et nostrum

20 primum non amplius quinque aut senis milibus passuum interesset.

16. Interim cotidie Caesar Haeduos frumentum, quod essent publice polliciti, flagitare. Nam propter frigora, quod Gallia sub septentrionibus (ut ante dic-

25 tum est) posita est, non modo frumenta in agris matura non erant, sed ne pabuli quidem satis magna copia suppetebat: eo autem frumento, quod flumine Arare navibus subvexerat, propterea minus uti poterat, quod iter ab Arare Helvetii averterant, a quibus discedere

30 nolebat. <sup>2</sup> Diem ex die ducere Haedui: *conferrī, comportari, adesse*, dicere. Ubi se diutius duci intellexit, et diem instare, quo die frumentum militibus metiri oporteret, convocatis eorum principibus, quorum magnam copiam in castris habebat, — in his Divitiaco et

35 Lisco, qui summo magistratui praeerat quem *vergobretum* appellant Haedui, qui creatur annuus, et vitae

necisque in suos habet potestatem, — <sup>3</sup>graviter eos accusat, quod, cum neque emi neque ex agris sumi posset, tam necessario tempore, tam propinquis hostibus, ab iis non sublevetur; praesertim cum magna ex parte eorum precibus adductus bellum susceperit, 5 multo etiam gravius quod sit destitutus queritur.

17. Tum demum Liscus, oratione Caesaris adductus, quod antea tacuerat proponit: 'Esse nonnullos, quorum auctoritas apud plebem plurimum valeat, qui privatim plus possint quam ipsi magistratus. <sup>2</sup>Hos 10 seditiosa atque improba oratione multitudinem deterere, ne frumentum conferant, quod praestare debeant: si jam principatum Galliae obtinere non possint, Gallorum quam Romanorum imperia praeferre; neque dubitare [debeant] quin, si Helvetios superaverint Ro- 15 mani, una cum reliqua Gallia Haeduis libertatem sint erepturi. <sup>3</sup>Ab eisdem nostra consilia, quaeque in castris gerantur, hostibus enuntiari; hos a se coërceri non posse. Quin etiam, quod necessario rem coactus Caesari enuntiarit, intellegere sese quanto id cum 20 periculo fecerit, et ob eam causam, quam diu potuerit, tacuisse.'

18. Caesar hac oratione Lisci Dumnorigem, Divitiaci fratrem, designari sentiebat; sed, quod pluribus praesentibus eas res jactari nolebat, celeriter concilium 25 dimittit, Liscum retinet. <sup>2</sup>Quaerit ex solo ea quae in conventu dixerat. Dicit liberius atque audacius. Eadem secreto ab aliis quaerit; reperit esse vera: 'Ipsum esse Dumnorigem, summa audacia, magna apud plebem propter liberalitatem gratia, cupidum 30 rerum novarum. <sup>3</sup>Complures annos portoria reliquaque omnia Haeduum vectigalia parvo pretio redempta habere, propterea quod illo licente contra liceri audeat nemo. <sup>4</sup>Iis rebus et suam rem familiarem auxisse, et facultates ad largiendum magnas com- 35 parasse; magnum numerum equitatus suo sumptu

semper alere et circum se habere, neque solum domi, sed etiam apud finitimas civitates largiter posse; atque hujus potentiae causa matrem in Biturigibus homini illic nobilissimo ac potentissimo collocasse, ipsum ex  
 5 Helvetiis uxorem habere, sororem ex matre et propinquas suas nuptum in alias civitates collocasse. <sup>5</sup>Favere et cupere Helvetiis propter eam adfinitatem, odisse etiam suo nomine Caesarem et Romanos, quod eorum adventu potentia ejus deminuta, et Divitiacus frater in  
 10 antiquum locum gratiae atque honoris sit restitutus. <sup>6</sup>Si quid accidat Romanis, summam in spem per Helvetios regni obtinendi venire; imperio populi Romani non modo de regno, sed etiam de ea quam habeat gratia, desperare. <sup>7</sup>Reperiebat etiam in quaerendo  
 15 Caesar, quod proelium equestre adversum paucis ante diebus esset factum, initium ejus fugae factum a Dumnorige atque ejus equitibus, — nam equitatu, quem auxilio Caesari Haedui miserant, Dumnorix praecerat: eorum fuga reliquum esse equitatum perterritum.  
 20 19. Quibus rebus cognitis, cum ad has suspensiones certissimae res accederent, — quod per fines Sequanorum Helvetios traduxisset, quod obsides inter eos dando curasset, quod ea omnia non modo injussu suo et civitatis, sed etiam inscientibus ipsis fecisset, quod a  
 25 magistratu Haeduorum accusaretur, — satis esse causae arbitrabatur, quare in eum aut ipse animadverteret, aut civitatem animadvertere juberet. <sup>2</sup>His omnibus rebus unum repugnabat, quod Divitiaci fratris summum in populum Romanum studium, summam in se  
 30 voluntatem, egregiam fidem, justitiam, temperantiam cognoverat: nam ne ejus supplicio Divitiaci animus offenderet verebatur. <sup>3</sup>Itaque prius quam quicquam conaretur, Divitiacum ad se vocari jubet, et quotidianis interpretibus remotis, per C. Valerium  
 35 Procillum, principem Galliae provinciae, familiarem suum, cui summam omnium rerum fidem habebat,

cum eo colloquitur; <sup>4</sup>simul commonefacit quae ipso praesente in concilio Gallorum de Dumnorige sint dicta; et ostendit quae separatim quisque de eo apud se dixerit; petit atque hortatur, ut sine ejus offensione animi vel ipse de eo causa cognita statuatur, vel civitatem statuere jubeat. 5

20. Divitiacus, multis cum lacrimis Caesarem complexus, obsecrare coepit, ne quid gravius in fratrem statueret: <sup>2</sup>'Scire se illa esse vera, nec quemquam ex eo plus quam se doloris capere, propterea quod, cum ipse gratia plurimum domi atque in reliqua Gallia, ille minimum propter adulescentiam posset, per se crevisset; quibus opibus ac nervis non solum ad minuendam gratiam, sed paene ad perniciem suam uteretur; sese tamen et amore fraterno et existimatione vulgi commoveri. <sup>3</sup>Quod si quid ei a Caesare gravius accidisset, cum ipse eum locum amicitiae apud eum teneret, neminem existimaturum non sua voluntate factum; qua ex re futurum, uti totius Galliae animi a se averterentur.' <sup>4</sup>Haec cum pluribus verbis flens a Caesare peteret, Caesar ejus dextram prendit; consolatus rogat, finem orandi faciat; tanti ejus apud se gratiam esse ostendit, uti et reipublicae injuriam et suum dolorem ejus voluntati ac precibus condonet. <sup>5</sup>Dumnorigem ad se vocat, fratrem adhibet; quae in eo reprehendat, ostendit, quae ipse intellegat, quae civitas queratur, proponit; monet ut in reliquum tempus omnes suspitiones vitet; praeterita se Divitiaco fratri condonare dicit. Dumnorigi custodes ponit, ut quae agat, quibuscum loquatur, scire possit. 30

21. Eodem die ab exploratoribus certior factus hostes sub monte consedissee milia passuum ab ipsius castris octo, qualis esset natura montis et qualis in circuitu ascensus, qui cognoscerent misit. <sup>2</sup>Renuntiatum est facilem esse. De tertia vigilia T. Labienum, <sup>35</sup> legatum pro praetore, cum duabus legionibus et iis

ducibus qui iter cognoverant, summum jugum montis ascendere jubet; quid sui consilii sit ostendit. Ipse de quarta vigilia eodem itinere, quo hostes ierant, ad eos contendit, equitatumque omnem ante se mittit. <sup>3</sup>P. 5 Considius, qui rei militaris peritissimus habebatur, et in exercitu L. Sullae et postea in M. Crassi fuerat, cum exploratoribus praemittitur.

22. Prima luce, cum summus mons a Labieno tene- retur, ipse ab hostium castris non longius mille et 10 quingentis passibus abesset, neque, ut postea ex capti- vis comperit, aut ipsius adventus aut Labieni cognitus esset, Considius equo admissio ad eum accurrit; <sup>2</sup>dicit montem, quem a Labieno occupari voluerit, ab hos- tibus teneri; id se a Gallicis armis atque insignibus 15 cognovisse. Caesar suas copias in proximum collem subducit, aciem instruit. <sup>3</sup>Labienus, ut erat ei prae- ceptum a Caesare, ne proelium committeret, nisi ipsius copiae prope hostium castra visae essent, ut undique uno tempore in hostes impetus fieret, monte occupato 20 nostros exspectabat, proelioque abstinebat. <sup>4</sup>Multo denique die per exploratores Caesar cognovit et mon- tem a suis teneri, et Helvetios castra movisse, et Con- sidium, timore perterritum, quod non vidisset pro viso sibi renuntiassse. Eo die, quo consuerat intervallo, 25 hostes sequitur, et milia passuum tria ab eorum castris castra ponit.

23. Postridie ejus diei, quod omnino biduum super- erat, cum exercitui frumentum metiri oporteret, et quod a Bibracte, oppido Haeduum longe maximo et 30 copiosissimo, non amplius milibus passuum XVIII ab- erat, rei frumentariae prospiciendum existimavit: iter ab Helvetiis avertit, ac Bibracte ire contendit. <sup>2</sup>Ea res per fugitivos L. Aemilii, decurionis equitum Gallo- rum, hostibus nuntiatur. <sup>3</sup>Helvetii, seu quod timore 35 perterritos Romanos discedere a se existimarent, eo magis quod pridie, superioribus locis occupatis, proe-



lium non commisissent, sive eo quod re frumentaria intercludi posse confiderent, commutato consilio atque itinere converso, nostros a novissimo agmine insequi ac lacesere coeperunt.

24. Postquam id animum advertit, copias suas Caesar in proximum collem subducit, equitatumque, qui sustineret hostium impetum, misit. <sup>2</sup>Ipse interim in colle medio triplicem aciem instruxit legionum quatuor veteranarum [ita uti supra]; sed in summo jugo duas legiones, quas in Gallia citeriore proxime conscripserat, et omnia auxilia conlocari, ac totum montem hominibus compleri, et interea sarcinas in unum locum conferri, et eum ab his qui in superiore acie constiterant muniri jussit. <sup>3</sup>Helvetii cum omnibus suis carris secuti, impedimenta in unum locum contulerunt; ipsi confertissima acie, rejecto nostro equitatu, phalange facta, sub primam nostram aciem successerunt.

25. Caesar primum suo, deinde omnium ex conspectu remotis equis, ut aequato omnium periculo spem fugae tolleret, cohortatus suos proelium commisit. Milites e loco superiore, pilis missis, facile hostium phalangem perfregerunt. <sup>2</sup>Ea disjecta, gladiis dstrictis in eos impetum fecerunt. Gallis magno ad pugnam erat impedimento, quod pluribus eorum scutis uno ictu pilorum transfixis et conligatis, cum ferrum se inflexisset, neque evellere neque sinistra impedita satis commode pugnare poterant, multi ut, diu jactato brachio, praeoptarent scutum manu emittere, et nudo corpore pugnare. <sup>3</sup>Tandem vulneribus defessi, et pedem referre et, quod mons suberat circiter mille passuum, eo se recipere coeperunt. <sup>4</sup>Capto monte et succedentibus nostris, Boii et Tulingi, qui hominum milibus circiter xv agmen hostium claudabant, et novissimis praesidio erant, ex itinere nostros latere aperto adgressi circumvenire; <sup>5</sup>et id conspicati Helvetii, qui in montem sese receperant, rursus instare

et proelium redintegrare coeperunt. Romani conversa signa bipartito intulerunt: prima et secunda acies, ut victis ac summotis resisteret; tertia, ut venientes sustineret.

5 26. Ita ancipiti proelio diu atque acriter pugnatum est. Diutius cum sustinere nostrorum impetus non possent, alteri se, ut coeperant, in montem receperunt, alteri ad impedimenta et carros suos se contulerunt. <sup>2</sup>Nam hoc toto proelio, cum ab hora septima ad ves-

10 perum pugnatum sit, aversum hostem videre nemo potuit. Ad multam noctem etiam ad impedimenta pugnatum est, propterea quod pro vallo carros objecerant, et e loco superiore in nostros venientes tela coniciebant, et nonnulli inter carros rotasque mataras

15 ac tragulas subiciebant, nostrosque vulnerabant. <sup>3</sup>Diu cum esset pugnatum, impedimentis castrisque nostri potiti sunt. Ibi Orgetorigis filia atque unus e filiis captus est. <sup>4</sup>Ex eo proelio circiter hominum milia cxxx superfuerunt, eaque tota nocte continenter

20 ierunt: nullam partem noctis itinere intermisso, in fines Lingonum die quarto pervenerunt, cum et propter vulnera militum, et propter sepulturam occisorum, nostri triduum morati eos sequi non potuissent. <sup>5</sup>Caesar ad Lingonas litteras nuntiosque misit, ne eos fru-

25 mento neve alia re juvarent: qui si juvissent, se eodem loco quo Helvetios habiturum. Ipse, triduo intermisso, cum omnibus copiis eos sequi coepit.

27. Helvetii, omnium rerum inopia adducti, legatos de deditioe ad eum miserunt. Qui cum eum in

30 itinere convenissent, seque ad pedes projecissent, suppliciterque locuti flentes pacem petissent, atque eos in eo loco, quo tum essent, suum adventum exspectare jussisset, paruerunt. <sup>2</sup>Eo postquam Caesar pervenit, obsides, arma, servos, qui ad eos perfugissent, po-

35 scit. Dum ea conquiruntur et conferuntur, nocte intermissa, circiter hominum milia vi ejus pagi qui *Verbigenus* appellatur, sive timore perterriti, ne armis

traditis supplicio adficerentur, sive spe salutis inducti, quod in tanta multitudine dediticiorum suam fugam aut occultari aut omnino ignorari posse existimarent, prima nocte e castris Helvetiorum egressi, ad Rhenum finesque Germanorum contenderunt.

5

28. Quod ubi Caesar rescit, quorum per fines ierant, his, uti conquirerent et reducerent, si sibi purgati esse vellent, imperavit: reductos in hostium numero habuit; reliquos omnes, obsidibus, armis, perfugis traditis, in deditionem accepit. <sup>2</sup>Helvetios, Tu- 10 lingos, Latobrigos in fines suos, unde erant profecti, reverti iussit; et quod, omnibus fructibus amissis, domi nihil erat quo famem tolerarent, Allobrogibus imperavit, ut iis frumenti copiam facerent; ipsos oppida vicosque, quos incenderant, restituere iussit. <sup>3</sup>Id ea 15 maxime ratione fecit, quod noluit eum locum, unde Helvetii discesserant, vacare, ne propter bonitatem agrorum Germani, qui trans Rhenum incolunt, e suis finibus in Helvetiorum fines transirent, et finitimi Galliae provinciae Allobrogibusque essent. <sup>4</sup>Boios, pe- 20 tentibus Haeduis, quod egregia virtute erant cogniti, ut in finibus suis collocarent, concessit; quibus illi agros dederunt, quosque postea in parem juris libertatisque condicionem atque ipsi erant receperunt.

29. In castris Helvetiorum tabulae repertae sunt 25 litteris Graecis confectae et ad Caesarem relatae, quibus in tabulis nominatim ratio confecta erat, qui numerus domo exisset eorum qui arma ferre possent, et item separatim pueri, senes mulieresque. <sup>2</sup>Quarum omnium rerum summa erat capitum Helvetiorum milia 30 CCLXIII, Tulingorum milia XXXVI, Latobrigorum XIII, Rauracorum XXIII, Boiorum XXXII; ex his qui arma ferre possent, ad milia XCII. <sup>3</sup>Summa omnium fuerunt ad milia CCCLXVIII. Eorum qui domum redierunt, censu habito, ut Caesar imperaverat, repertus 35 est numerus milium C et X.

30. Bello Helvetiorum confecto, totius fere Galliae legati, principes civitatum, ad Caesarem gratulatum convenerunt: 'Intellegere sese, tametsi pro veteribus Helvetiorum injuriis populi Romani ab his poenas  
5 bello repetisset, tamen eam rem non minus ex usu terrae Galliae quam populi Romani accidisse; <sup>2</sup>propterea quod eo consilio, florentissimis rebus, domos suas Helvetii reliquissent, uti toti Galliae bellum inferrent, imperioque potirentur, locumque domicilio ex magna copia  
10 deligerent, quem ex omni Gallia opportunissimum ac fructuosissimum judicassent, reliquasque civitates stipendiarias haberent.' <sup>3</sup>Petierunt, uti sibi concilium totius Galliae in diem certam indicere idque Caesaris voluntate facere liceret: sese habere quasdam res,  
15 quas ex communi consensu ab eo petere vellent. <sup>4</sup>Ea re permissa, diem concilio constituerunt, et jurejurando, ne quis enuntiaret, nisi quibus communi consilio mandatum esset, inter se sanxerunt.

31. Eo concilio dimisso, idem principes civitatum,  
20 qui ante fuerant, ad Caesarem reverterunt, petieruntque, uti sibi secretò in occulto de sua omniumque salute cum eo agere liceret. <sup>2</sup>Ea re impetrata, sese omnes flentes Caesari ad pedes projecerunt: 'Non minus se id contendere et laborare, ne ea quae dix-  
25 issent enuntiarentur, quam uti ea quae vellent impetrarent; propterea quod, si enuntiatum esset, summum in cruciatum se venturos viderent.' <sup>3</sup>Locutus est pro his Divitiacus Haedus: 'Galliae totius factiones esse duas; harum alterius principatum tenere Haeduos,  
30 alterius Arvernos. Hi cum tantopere de potentatu inter se multos annos contenderent, factum esse, uti ab Arvernibus Sequanisque Germani mercede arcesse-  
rentur. <sup>4</sup>Horum primo circiter milia xv Rhenum transisse; posteaquam agros et cultum et copias Gallorum  
35 homines feri ac barbari adamassent, traductos plures; nunc esse in Gallia ad centum et xx milium numerum.

<sup>5</sup>Cum his Haeduos eorumque clientes semel atque iterum armis contendisse; magnam calamitatem pulsos accepisse, omnem nobilitatem, omnem senatum, omnem equitatum amisisse. <sup>6</sup>Quibus proeliis calamitatibusque fractos, qui et sua virtute et populi Romani hospitio atque amicitia plurimum ante in Gallia potuissent, coactos esse Sequanis obsides dare nobilissimos civitatis, et jurejurando civitatem obstringere, sese neque obsides repetituros, neque auxilium a populo Romano imploratorios, neque recusatorios quo minus perpetuo sub illorum ditione atque imperio essent. <sup>7</sup>Unum se esse ex omni civitate Haeduatorum, qui adduci non potuerit ut juraret, aut liberos suos obsides daret. Ob eam rem se ex civitate profugisse, et Romam ad senatum venisse auxilium postulatum, quod solus neque jurejurando neque obsidibus teneretur. <sup>8</sup>Sed pejus victoribus Sequanis quam Haeduis victis accidisse, propterea quod Ariovistus, rex Germanorum, in eorum finibus consedisset, tertiamque partem agri Sequani, qui esset optimus totius Galliae, occupavisset, et nunc de altera parte tertia Sequanos decedere juberet, propterea quod paucis mensibus ante Harudum milia hominum *XXIII* ad eum venissent, quibus locus ac sedes pararentur. <sup>9</sup>Futurum esse paucis annis, uti omnes ex Galliae finibus pellerentur, atque omnes Germani Rhenum transirent; neque enim conferendum esse Gallicum cum Germanorum agro, neque hanc consuetudinem victus cum illa comparandam. <sup>10</sup>Ariovistum autem, ut semel Gallorum copias proelio vicerit, quod proelium factum sit Admagetobrigae; superbe et crudeliter imperare, obsides nobilissimi cujusque liberos poscere, et in eos omnia exempla cruciatusque edere, si qua res non ad nutum aut ad voluntatem ejus facta sit. <sup>11</sup>Hominem esse barbarum, iracundum, temerarium: non posse ejus imperia diutius sustinere. Nisi si quid in Caesare populoque Romano sit auxilii,

omnibus Gallis idem esse faciendum quod Helvetii fecerint, ut domo emigrent, aliud domicilium alias sedes, remotas a Germanis, petant, fortunamque, quaecumque accidat, experiantur. <sup>12</sup> Haec si enuntiata  
 5 Ariovisto sint, non dubitare, quin de omnibus obsidibus, qui apud eum sint, gravissimum supplicium sumat. Caesarem vel auctoritate sua atque exercitus, vel recenti victoria, vel nomine populi Romani, deterere posse, ne major multitudo Germanorum Rhenum  
 10 traducatur, Galliamque omnem ab Ariovisti injuria posse defendere.'

32. Hac oratione ab Divitiaco habita, omnes qui aderant magno fletu auxilium a Caesare petere coeperunt. Animadvertit Caesar unos ex omnibus Sequa-  
 15 nos nihil earum rerum facere quas ceteri facerent, sed tristes, capite demisso, terram intueri. <sup>2</sup> Ejus rei quae causa esset miratus, ex ipsis quaesit. Nihil Sequani respondere, sed in eadem tristitia taciti permanere. Cum ab his saepius quaereret, neque ullam omnino  
 20 vocem exprimere posset, idem Divitiacus Haedus respondit: <sup>3</sup> 'Hoc esse miseriorem et graviorem fortunam Sequanorum quam reliquorum, quod soli ne in occulto quidem queri neque auxilium implorare aude-  
 rent; absentisque Ariovisti crudelitatem, velut si coram  
 25 adesset, horrerent, propterea quod reliquis tamen fugae facultas daretur, Sequanis vero, qui intra fines suos Ariovistum recepissent, quorum oppida omnia in potestate ejus essent, omnes cruciatus essent perferendi.'

33. His rebus cognitis, Caesar Gallorum animos  
 30 verbis confirmavit, pollicitusque est sibi eam rem curae futuram; magnam se habere spem, et beneficio suo et auctoritate adductum Ariovistum finem injuriis facturum. Hac oratione habita, concilium dimisit. <sup>2</sup> Et secundum ea multae res eum hortabantur, quare  
 35 sibi eam rem cogitandam et suscipiendam putaret: imprimis, quod Haeduos, fratres consanguineosque

saepenumero a senatu appellatos, in servitute atque in  
dicione videbat Germanorum teneri, eorumque obsides  
esse apud Ariovistum ac Sequanos intellegebat; quod  
in tanto imperio populi Romani turpissimum sibi et  
reipublicae esse arbitrabatur. <sup>3</sup>Paulatim autem Ger- 5  
manos consuescere Rhenum transire, et in Galliam  
magnam eorum multitudinem venire, populo Romano  
periculosum videbat; neque sibi homines feros ac  
barbaros temperaturos existimabat, quin, cum omnem  
Galliam occupavissent, ut ante Cimbri Teutonique 10  
fecissent, in provinciam exirent, atque inde in Italiam  
contenderent; <sup>4</sup>praesertim cum Sequanos a provincia  
nostra Rhodanus divideret: quibus rebus quam ma-  
turrime occurrendum putabat. Ipse autem Ariovistus  
tantos sibi spiritus, tantam arrogantiam sumpserat, ut 15  
ferendus non videretur.

34. Quamobrem placuit ei, ut ad Ariovistum legatos  
mitteret, qui ab eo postularent, uti aliquem locum  
medium utriusque conloquio deligeret: velle sese de  
re publica et summis utriusque rebus cum eo agere. 20  
<sup>2</sup>Ei legationi Ariovistus respondit: 'Si quid ipsi a  
Caesare opus esset, sese ad eum venturum fuisse; si  
quid ille se velit, illum ad se venire oportere. <sup>3</sup>Prae-  
terea se neque sine exercitu in eas partes Galliae  
venire audere, quas Caesar possideret, neque exerci- 25  
tum sine magno comœatu atque molimento in unum  
locum contrahere posse. <sup>4</sup>Sibi autem mirum videri,  
quid in sua Gallia, quam bello vicisset, aut Caesari aut  
omnino populo Romano negotii esset.'

35. His responsis ad Caesarem relatis, iterum ad 30  
eum Caesar legatos cum his mandatis mittit: 'Quo-  
niam tanto suo populique Romani beneficio adfectus,  
cum in consulatu suo rex atque amicus a senatu appel-  
latus esset, hanc sibi populoque Romano gratiam  
referret, ut in conloquium venire invitatus gravaretur, 35  
neque de communi re dicendum sibi et cognoscendum

putaret, haec esse quae ab eo postularet: <sup>2</sup>primum, ne quam multitudinem hominum amplius trans Rhenum in Galliam traduceret; deinde obsides, quos haberet ab Haeduis, redderet, Sequanisque permetteret, ut quos illi haberent, voluntate ejus reddere illis liceret; neve Haeduos injuria lacesseret, neve his sociisque eorum bellum inferret. <sup>3</sup>Si id ita fecisset, sibi populoque Romano perpetuam gratiam atque amicitiam cum eo futuram: si non impetraret, sese,—quoniam,   
 10 M. Messala M. Pisone consulibus, senatus censuisset uti quicumque Galliam provinciam obtineret, quod commodo reipublicae facere posset, Haeduos ceterosque amicos populi Romani defenderet,—se Haeduum injurias non neglecturum.’

15 36. Ad haec Ariovistus respondit: ‘Jus esse belli, ut qui vicissent, iis quos vicissent, quem ad modum vellent, imperarent: item populum Romanum victis non ad alterius praescriptum, sed ad suum arbitrium, imperare consuesse. <sup>2</sup>Si ipse populo Romano non   
 20 praescriberet quem ad modum suo jure uteretur, non oportere sese a populo Romano in suo jure impediri. <sup>3</sup>Haeduos sibi, quoniam belli fortunam temptassent, et armis congressi ac superati essent, stipendiarios esse factos. Magnam Caesarem injuriam facere, qui suo   
 25 adventu vectigalia sibi deteriora faceret. <sup>4</sup>Haeduis se obsides redditurum non esse, neque iis neque eorum sociis injuria bellum inlaturum, si in eo manerent quod convenisset, stipendiumque quotannis penderent; si id non fecissent, longe iis fraternum nomen populi Ro-   
 30 mani afuturum. <sup>5</sup>Quod sibi Caesar denuntiaret se Haeduum injurias non neglecturum, neminem secum sine sua pernicie contendisse. Cum vellet, congrederetur: intellecturum quid invicti Germani, exercitissimi in armis, qui inter annos XIV tectum non   
 35 subissent, virtute possent.’

37. Haec eodem tempore Caesari mandata refere-



bantur, et legati ab Haeduis et a Treveris veniebant : Haedui questum, quod Harudes, qui nuper in Galliam transportati essent, fines eorum popularentur : <sup>2</sup> sese ne obsidibus quidem datis pacem Ariovisti redimere potuisse ; Treveri autem, pagos centum Suevorum ad ripam Rheni consedis- 5  
 se, qui Rhenum transire conarentur ; his praesse Nasuam et Cimberium fratres. <sup>3</sup> Quibus rebus Caesar vehementer commotus, maturandum sibi existimavit, ne, si nova manus Suevorum cum veteribus copiis Ariovisti sese conjunxisset, minus 10  
 facile resisti posset. Itaque, re frumentaria quam celerrime potuit comparata, magnis itineribus ad Ariovistum contendit.

38. Cum tridui viam processisset, nuntiatum est ei Ariovistum cum suis omnibus copiis ad occupandum 15  
 Vesontionem, quod est oppidum maximum Sequanorum, contendere, triduique viam a suis finibus profecisse. <sup>2</sup> Id ne accideret, magnopere sibi praecavendum Caesar existimabat. Namque omnium rerum, quae ad bellum usui erant, summa erat in eo oppido facul- 20  
 tas ; idque natura loci sic muniebatur, ut magnam ad ducendum bellum daret facultatem, propterea quod flumen [alduas] Dubis ut circino circumductum paene totum oppidum cingit ; <sup>3</sup> reliquum spatium, quod est non amplius pedum sexcentorum, qua flumen intermittit, 25  
 mons continet magna altitudine, ita ut radices montis ex utraque parte ripae fluminis contingant. <sup>4</sup> Hunc murus circumdatus arcem efficit, et cum oppido conjungit. Huc Caesar magnis nocturnis diurnisque itineribus contendit, occupatoque oppido, ibi praesi- 30  
 dium conlocat.

39. Dum paucos dies ad Vesontionem rei frumentariae commeatusque causa moratur, ex percontatione nostrorum vocibusque Gallorum ac mercatorum, qui ingenti magnitudine corporum Germanos, incredibili 35  
 virtute atque exercitatione in armis esse praedicabant,

—saepenumero sese cum his congressos ne vultum quidem atque aciem oculorum dicebant ferre potuisse, — tantus subito timor omnem exercitum occupavit, ut non mediocriter omnium mentes animosque perturbaret. <sup>2</sup>Hic primum ortus est a tribunis militum, praefectis, reliquisque, qui, ex urbe amicitiae causa Caesarem secuti, non magnum in re militari usum habebant: quorum alius alia causa inlata, quam sibi ad proficiscendum necessariam esse diceret, petebat ut ejus voluntate discedere liceret; nonnulli pudore adducti, ut timoris suspicionem vitarent, remanebant. <sup>3</sup>Hi neque vultum fingere neque interdum lacrimas tenere poterant: abditi in tabernaculis aut suum fatum querebantur, aut cum familiaribus suis commune periculum miserabantur. Volgo totis castris testamenta obsignabantur. <sup>4</sup>Horum vocibus ac timore paulatim etiam ii qui magnum in castris usum habebant, milites centurionesque quique equitatu praerant, perturbabantur. Qui se ex his minus timidos existimari volebant, non se hostem vereri, sed angustias itineris, magnitudinem silvarum quae intercederent inter ipsos atque Ariovistum, aut rem frumentariam, ut satis commode supportari posset, timere dicebant. <sup>5</sup>Nonnulli etiam Caesari nuntiabant, cum castra moveri ac signa ferri jussisset, non fore dicto audientes milites, neque propter timorem signa laturos.

40. Haec cum animadvertisset, convocato consilio, omniumque ordinum ad id consilium adhibitis centurionibus, vehementer eos incusavit: primum quod aut quam in partem aut quo consilio ducerentur sibi quaerendum aut cogitandum putarent. <sup>2</sup>'Ariovistum se consule cupidissime populi Romani amicitiam appetisse: cur hunc tam temere quisquam ab officio discessurum judicaret? Sibi quidem persuaderi, cognitio- nis suis postulatis atque aequitate condicionum perspecta, eum neque suam neque populi Romani gratiam

repudiaturum. <sup>3</sup> Quod si furore atque amentia impulsus bellum intulisset, quid tandem vererentur? aut cur de sua virtute aut de ipsius diligentia desperarent? <sup>4</sup> Factum ejus hostis periculum patrum nostrorum memoria, cum, Cimbris et Teutonis a Gaio Mario pulsus, non <sup>5</sup> minorem laudem exercitus quam ipse imperator meritus videbatur; factum etiam nuper in Italia servili tumultu, quos tamen aliquid usus ac disciplina, quae a nobis accepissent, sublevarent. <sup>5</sup> Ex quo judicari posse, quantum haberet in se boni constantia, propterea quod, quos aliquamdiu inermos sine causa timuissent, hos postea armatos ac victores superassent. <sup>6</sup> Denique hos esse eosdem, quibuscum saepenumero Helvetii congressi, non solum in suis, sed etiam in illorum finibus, plerumque superarint; qui tamen pares <sup>15</sup> esse nostro exercitui non potuerint. <sup>7</sup> Si quos adversum proelium et fuga Gallorum commoveret, hos, si quaerent, reperire posse, diuturnitate belli defetigatis Gallis, Ariovistum, cum multos menses castris se ac paludibus tenuisset, neque sui potestatem fecisset, <sup>20</sup> desperantes jam de pugna et dispersos subito adortum, magis ratione et consilio quam virtute vicisse. <sup>8</sup> Cui rationi contra homines barbaros atque imperitos locus fuisset, hac ne ipsum quidem sperare nostros exercitus capi posse. <sup>9</sup> Qui suum timorem in rei frumentariae <sup>25</sup> simulationem angustiasque itineris conferrent, facere arroganter, cum aut de officio imperatoris desperare aut praescribere viderentur. <sup>10</sup> Haec sibi esse curae: frumentum Sequanos, Leucos, Lingones subministrare, jamque esse in agris frumenta matura; de itinere ipsos <sup>30</sup> brevi tempore judicaturos. <sup>11</sup> Quod non fore dicto audientes neque signa laturo dicantur, nihil se ea re commoveri: scire enim, quibuscumque exercitus dicto audiens non fuerit, aut male re gesta fortunam defuisse, aut aliquo facinore comperto avaritiam esse convictam: <sup>35</sup> suam innocentiam perpetua vita, felicitatem Helvetio-

rum bello esse perspectam. <sup>12</sup> Itaque se quod in longiorem diem conlaturus fuisset repraesentaturum et proxima nocte de quarta vigilia castra moturum, u. l. quam primum intellegere posset, utrum apud eos pudor  
 5 atque officium an timor valeret. <sup>13</sup> Quod si praeterea nemo sequatur, tamen se cum sola decima legione iturum, de qua non dubitaret, sibique eam praetoriam cohortem futuram.' Huic legioni Caesar et indulserat praecipue, et propter virtutem confidebat maxime.

<sup>10</sup> 41. Hac oratione habita, mirum in modum conversae sunt omnium mentes, summaque alacritas et cupiditas belli gerendi innata est; princepsque decima legio per tribunos militum ei gratias egit, quod de se optimum iudicium fecisset, seque esse ad bellum  
 15 gerendum paratissimam confirmavit. <sup>2</sup> Deinde reliquae legiones cum tribunis militum et primorum ordinum centurionibus egerunt, uti Caesari satisfacerent: se neque umquam dubitasse, neque timuisse, neque de summa belli suum iudicium, sed imperatoris esse existi-  
 20 mavisse. <sup>3</sup> Eorum satisfactione accepta, et itinere exquisito per Divitiacum, quod ex aliis ei maximam fidem habebat, ut milium amplius quinquaginta circuitu locis apertis exercitum duceret, de quarta vigilia, ut dixerat, profectus est. <sup>4</sup> Septimo die, cum iter non inter-  
 25 mitteret, ab exploratoribus certior factus est, Ariovisti copias a nostris milibus passuum quattuor et viginti abesse.

42. Cognito Caesaris adventu, Ariovistus legatos ad eum mittit: quod antea de conloquio postulasset, id  
 30 per se fieri licere, quoniam propius accessisset, seque id sine periculo facere posse existimare. <sup>2</sup> Non respuit condicionem Caesar, jamque eum ad sanitatem reverti arbitrabatur, cum id, quod antea petenti denegasset, ultro polliceretur; magnamque in spem veniebat, pro  
 35 suis tantis populique Romani in eum beneficiis, cognitis suis postulatis, fore uti pertinacia desisteret.

<sup>3</sup>Dies conloquio dictus est ex eo die quintus. Interim saepe ultro citroque cum legati inter eos mitterentur, Ariovistus postulavit, ne quem peditem ad conloquium Cæsar adduceret: vereri se, ne per insidias ab eo circumveniretur; uterque cum equitatu veniret; alia ratione sese non esse venturum. <sup>4</sup>Cæsar, quod neque conloquium interposita causa tolli volebat, neque salutem suam Gallorum equitatu committere audebat, commodissimum esse statuit, omnibus equis Gallis equitibus detractis, eo legionarios milites legionis decimae, cui quam maxime confidebat, imponere, ut praesidium quam amicissimum, si quid opus facto esset, haberet. <sup>5</sup>Quod cum fieret, non inridicule quidam ex militibus decimae legionis dixit, plus quam pollicitus esset Cæsarem facere: pollicitum se in cohortis praetoriae loco decimam legionem habiturum; ad equum rescribere.

43. Planities erat magna, et in ea tumulus terrenus satis grandis. Hic locus aequo fere spatio ab castris Ariovisti et Cæsaris aberat. Eo, ut erat dictum, ad conloquium venerunt. <sup>2</sup>Legionem Cæsar, quam equis devexerat, passibus ducentis ab eo tumulo constituit. Item equites Ariovisti pari intervallo constiterunt. Ariovistus ex equis ut conloquerentur, et praeter se denos ut ad conloquium adducerent, postulavit. <sup>3</sup>Ubi eo ventum est, Cæsar initio orationis sua senatusque in eum beneficia commemoravit, quod rex appellatus esset a senatu, quod amicus, quod munera amplissime missa; quam rem et paucis contigisse, et pro magnis hominum officiis consuesse tribui docebat; illum, cum neque aditum neque causam postulandi justam haberet, beneficio ac liberalitate sua ac senatus ea praemia consecutum. <sup>4</sup>Docebat etiam, quam veteres quamque justae causae necessitudinis ipsis cum Haeduis intercederent, quae senatus consulta, quotiens quamque honorifica, in eos facta essent, ut omni tempore totius

Galliae principatum Haedui tenuissent, prius etiam quam nostram amicitiam appetissent. <sup>5</sup>Populi Romani hanc esse consuetudinem, ut socios atque amicos non modo sui nihil deperdere, sed gratia, dignitate, honore <sup>5</sup>auctiores velit esse: quod vero ad amicitiam populi Romani adtulissent, id iis eripi quis pati posset?' <sup>6</sup>Postulavit deinde eadem quae legatis in mandatis dederat: ne aut Haeduis aut eorum sociis bellum inferret; obsides redderet; si nullam partem Germanorum domum remittere posset, at ne quos amplius <sup>10</sup>Rhenum transire pateretur.

44. Ariovistus ad postulata Caesaris pauca respondit; de suis virtutibus multa praedicavit: 'Transisse Rhenum sese non sua sponte, sed rogatum et arcessitum a Gallis; non sine magna spe magnisque praemiis <sup>15</sup>domum propinquosque reliquisse; sedes habere in Gallia ab ipsis concessas, obsides ipsorum voluntate datos; stipendium capere jure belli, quod victores victis imponere consuerint. <sup>2</sup>Non sese Gallis, sed <sup>20</sup>Gallos sibi bellum intulisse; omnes Galliae civitates ad se oppugnandum venisse, ac contra se castra habuisse; eas omnes copias a se uno proelio pulsas ac superatas esse. <sup>3</sup>Si iterum experiri velint, se iterum paratum esse decertare; si pace uti velint, iniquum esse de stipendio recusare, quod sua voluntate <sup>25</sup>ad id tempus pependerit. Amicitiam populi Romani sibi ornamento et praesidio, non detrimento esse oportere, idque se ea spe petisse. <sup>4</sup>Si per populum Romanum stipendium remittatur, et dediticii subtrahantur, non minus libenter sese recusaturum populi <sup>30</sup>Romani amicitiam quam adpetierit. <sup>5</sup>Quod multitudinem Germanorum in Galliam traducat, id se sui muniendi, non Galliae impugnandae causa facere: ejus rei testimonium esse, quod nisi rogatus non venerit, et quod bellum non intulerit, sed defenderit. <sup>6</sup>Se <sup>35</sup>prius in Galliam venisse quam populum Romanum.

Nunquam ante hoc tempus exercitum populi Romani Galliae provinciae finibus egressum. Quid sibi vellet? cur in suas possessiones veniret? <sup>7</sup>Provinciam suam hanc esse Galliam, sicut illam nostram. Ut ipsi concedi non oporteret, si in nostros fines impetum <sup>5</sup> faceret, sic item nos esse iniquos, quod in suo jure se interpellaremus. <sup>8</sup>Quod fratres Haeduos appellatos diceret, non se tam barbarum neque tam imperitum esse rerum, ut non sciret neque bello Allobrogum proximo Haeduos Romanis auxilium tulisse, neque <sup>10</sup> ipsos, in his contentionibus quas Haedui secum et cum Sequanis habuissent, auxilio populi Romani usos esse. <sup>9</sup>Debere se suspicari simulata Caesarem amicitia, quod exercitum in Gallia habeat, sui opprimendi causa habere. Qui nisi decedat, atque exercitum <sup>15</sup> deducat ex his regionibus, sese illum non pro amico, sed hoste habiturum. <sup>10</sup>Quod si eum interfecerit, multis sese nobilibus principibusque populi Romani gratum esse facturum: id se ab ipsis per eorum nuntios compertum habere, quorum omnium gratiam atque <sup>20</sup> amicitiam ejus morte redimere posset. <sup>11</sup>Quod si discessisset, et liberam possessionem Galliae sibi tradidisset, magno se illum praemio remuneraturum, et quaecumque bella geri vellet, sine ullo ejus labore et periculo confecturum.' 25

45. Multa ab Caesare in eam sententiam dicta sunt, quare negotio desistere non posset; et 'Neque suam neque populi Romani consuetudinem pati, uti optime merentes socios desereret, neque se judicare Galliam potius esse Ariovisti quam populi Romani. <sup>2</sup>Bello <sup>30</sup> superatos esse Arvernos et Rutenos ab Q. Fabio Maximo, quibus populus Romanus ignovisset, neque in provinciam rede-gisset, neque stipendium imposuisset. <sup>3</sup>Quod si antiquissimum quodque tempus spectari oporteret, populi Romani justissimum esse in <sup>35</sup> Gallia imperium; si iudicium senatus observari oport-

teret, liberam debere esse Galliam, quam bello victam suis legibus uti voluisset.'

46. Dum haec in conloquio geruntur, Caesari nuntiatum est equites Ariovisti propius tumulum accedere, et ad nostros adequitare, lapides telaque in nostros conicere. <sup>2</sup>Caesar loquendi finem facit, seque ad suos recipit, suisque imperavit, ne quod omnino telum in hostes reicerent. <sup>3</sup>Nam etsi sine ullo periculo legionis delectae cum equitatu proelium fore videbat, tamen committendum non putabat, ut pulsus hostibus dici posset eos ab se per fidem in conloquio circumventos. <sup>4</sup>Posteaquam in vulgus militum elatum est, qua adrogantia in conloquio Ariovistus usus omni Gallia Romanis interdixisset, impetumque in nostros ejus equites fecissent, eaque res conloquium ut diremisset, multo major alacritas studiumque pugnandi majus exercitui injectum est.

47. Biduo post Ariovistus ad Caesarem legatos mittit: 'Velle se de his rebus, quae inter eos agi coeptae neque perfectae essent, agere cum eo: uti aut iterum conloquio diem constitueret, aut, si id minus vellet, e suis legatis aliquem ad se mitteret.' <sup>2</sup>Conloquendi Caesari causa visa non est; et eo magis, quod pridie ejus diei Germani retineri non poterant, quin in nostros tela conicerent. Legatum e suis sese magno cum periculo ad eum missurum, et hominibus feris objecturum existimabat. <sup>3</sup>Commodissimum visum est Gaium Valerium Procillum, C. Valeri Caburi filium, summa virtute et humanitate adulescentem, —cujus pater a Gaio Valerio Flacco civitate donatus erat, et propter fidem et propter linguae Gallicae scientiam, qua multa jam Ariovistus longinqua consuetudine utebatur, et quod in eo peccandi Germanis causa non esset, —ad eum mittere, et M. Metium, qui hospitio Ariovisti utebatur. <sup>4</sup>His mandavit, ut quae diceret Ariovistus cognoscerent, et ad se referrent. Quos cum



apud se in castris Ariovistus conspexisset, exercitu suo praesente conclamavit: 'Quid ad se venirent? an speculandi causa?' Conantes dicere prohibuit, et in catenas coniecit.

48. Eodem die castra promovit, et milibus passuum 5 sex a Caesaris castris sub monte consedit. Postridie ejus diei praeter castra Caesaris suas copias traduxit, et milibus passuum duobus ultra eum castra fecit, eo consilio, uti frumento commeatuque, qui ex Sequanis et Haeduis supportaretur, Caesarem intercluderet. 10  
<sup>2</sup>Ex eo die dies continuos quinque Caesar pro castris suas copias produxit, et aciem instructam habuit, ut, si vellet Ariovistus proelio contendere, ei potestas non deesset. <sup>3</sup>Ariovistus his omnibus diebus exercitum castris continuit, equestri proelio cotidie contendit. 15  
 Genus hoc erat pugnae, quo se Germani exercuerant. <sup>4</sup>Equitum milia erant sex, totidem numero pedites velocissimi ac fortissimi, quos ex omni copia singuli singulos suae salutis causa delegerant: cum his in proeliis versabantur. <sup>5</sup>Ad eos se equites recipiebant: 20  
 hi, si quid erat durius, concurrebant; si qui, graviore vulnere accepto, equo deciderat, circumstabant; si quo erat longius prodeundum, aut celerius recipiendum, tanta erat horum exercitatione celeritas, ut jubeat equorum sublevati cursum adaequarent. 25

49. Ubi eum castris se tenere Caesar intellexit, ne diutius commeatu prohiberetur, ultra eum locum, quo in loco Germani consederant, circiter passus sexcentos ab iis, castris idoneum locum delegit, acieque triplici instructa ad eum locum venit. <sup>2</sup>Primam et secundam 30  
 aciem in armis esse, tertiam castra munire jussit. Hic locus ab hoste circiter passus sexcentos, uti dictum est, aberat. Eo circiter hominum numero sedecim milia expedita cum omni equitatu Ariovistus misit, quae copiae nostros perterrerent et munitione prohibe- 35  
 rent. <sup>3</sup>Nihilo secius Caesar, ut ante constituerat,

duas acies hostem propulsare, tertiam opus perficere jussit. Munitis castris, duas ibi legiones reliquit et partem auxiliorum, quattuor reliquas in castra majora reduxit.

5 50. Proximo die, instituto suo, Caesar e castris utrisque copias suas eduxit, paulumque a majoribus castris progressus, aciem instruxit, hostibus pugnandi potestatem fecit. <sup>2</sup> Ubi ne tum quidem eos prodire intellexit, circiter meridiem exercitum in castra reduxit.  
 10 Tum demum Ariovistus partem suarum copiarum, quae castra minora oppugnaret, misit. <sup>3</sup> Acriter utrimque usque ad vesperum pugnatum est. Solis occasu, suas copias Ariovistus, multis et inlatis et acceptis vulneribus, in castra reduxit. <sup>4</sup> Cum ex captivis quae-  
 15 reret Caesar, quamobrem Ariovistus proelio non decertaret, hanc reperiebat causam, quod apud Germanos ea consuetudo esset, ut matresfamiliae eorum sortibus et vaticinationibus declararent, utrum proelium committi ex usu esset necne; eas ita dicere: 'Non esse  
 20 fas Germanos superare, si ante novam lunam proelio contendissent.'

51. Postridie ejus diei Caesar praesidium utrisque castris quod satis esse visum est reliquit, omnes alarios in conspectu hostium pro castris minoribus constituit,  
 25 quod minus multitudine militum legionariorum pro hostium numero valebat, ut ad speciem alariis uteretur; ipse, triplici instructa acie, usque ad castra hostium accessit. <sup>2</sup> Tum demum necessario Germani suas copias castris eduxerunt, generatimque constituerunt paribus intervallis, Harudes, Marcomannos, Triboces, Vangiones, Nemetes, Sedusios, Suevos, omnemque aciem suam rhedis et carris circumdederunt, ne qua spes in fuga relinqueretur. <sup>3</sup> Eo mulieres imposuerunt, quae in proelium proficiscentes passis  
 30 manibus flentes implorabant, ne se in servitatem Romanis traderent.

52. Caesar singulis legionibus singulos legatos et quaestorem praefecit, uti eos testes suae quisque virtutis haberet; ipse a dextro cornu, quod eam partem minime firmam hostium esse animadverterat, proelium commisit. <sup>2</sup>Ita nostri acriter in hostes, signo dato, impetum fecerunt, ita-que hostes repente celeriterque procurrerunt, ut spatium pila in hostes coniciendi non daretur. Rejectis pilis, cominus gladiis pugnatum est. <sup>3</sup>At Germani celeriter, ex consuetudine sua phalange facta, impetus gladiatorum exceperunt. Re-<sup>10</sup>perti sunt complures nostri milites, qui in phalangas insilirent, et scuta manibus revellerent, et desuper vulnerarent. <sup>4</sup>Cum hostium acies a sinistro cornu pulsa atque in fugam conversa esset, a dextro cornu vehementer multitudine suorum nostram aciem preme-<sup>15</sup>bant. <sup>5</sup>Id cum animadvertisset P. Crassus adulescens, qui equitatu praerat, quod expeditior erat quam ii qui inter aciem versabantur, tertiam aciem laborantibus nostris subsidio misit.

53. Ita proelium restitutum est, atque omnes hostes <sup>20</sup>terga verterunt, neque prius fugere destiterunt, quam ad flumen Rhenum, milia passuum ex eo loco circiter quinquaginta pervenerunt. <sup>2</sup>Ibi perpauci aut viribus confisi tranare contenderunt, aut lintribus inventis sibi salutem pepererunt. In his fuit Ariovistus, qui navi-<sup>25</sup>culam deligatam ad ripam nactus ea profugit: reliquos omnes equitatu consecuti nostri interfecerunt. <sup>3</sup>Duae fuerunt Ariovisti uxores, una Sueva natione, quam domo secum duxerat, altera Norica, regis Voctionis soror, quam in Gallia duxerat a fratre missam: utrae-<sup>30</sup>que in ea fuga perierunt. Duae filiae harum altera occisa, altera capta est. <sup>4</sup>Gaius Valerius Procillus, cum a custodibus in fuga trinīs catenis vinctus traheretur, in ipsum Caesarem, hostes equitatu persequentem, incidit. <sup>5</sup>Quae quidem res Caesari non minorem quam <sup>35</sup>ipsa victoria voluptatem adtulit, quod hominem hones-

tissimum provinciae Galliae, suum familiarem et hospitem, ereptum e manibus hostium, sibi restitutum videbat; neque ejus calamitate de tanta voluptate et gratulatione quicquam fortuna deminuerat. <sup>6</sup> Is se  
5 praesente de se ter sortibus consultum dicebat, utrum  
igni statim necaretur, an in aliud tempus reservaretur:  
sortium beneficio se esse incolumem. Item M. Metius  
reperitus et ad eum reductus est.

54. Hoc proelio trans Rhenum nuntiato, Suevi, qui  
10 ad ripas Rheni venerant, domum reverti coeperunt;  
quos Ubii, qui proximi Rhenum incolunt, perterritos  
[senserunt;] insecuti, magnum ex his numerum occi-  
derunt. <sup>2</sup> Caesar una aestate duobus maximis bellis  
15 bat, in hiberna in Sequanos exercitum deduxit; hiber-  
nis Labienum praeposuit; ipse in citeriorem Galliam  
ad conventus agendos profectus est.



Longitude East from Greenwich

3°

4°

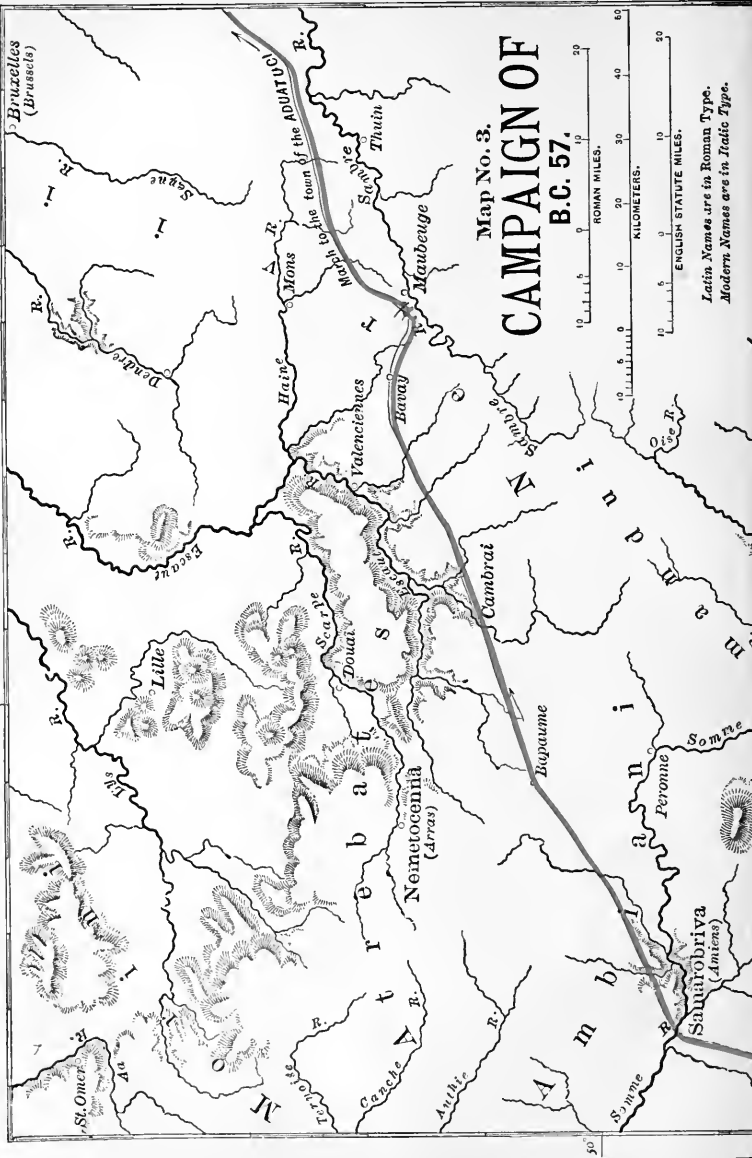

Map No. 3.  
**CAMPAIGN OF**  
**B.C. 57.**

10 20 30 40 50  
 ROMAN MILES.

10 20 30 40 50  
 KILOMETERS.

10 20 30 40 50  
 ENGLISH STATUTE MILES.

*Latin Names are in Roman Type.*  
*Modern Names are in Italic Type.*

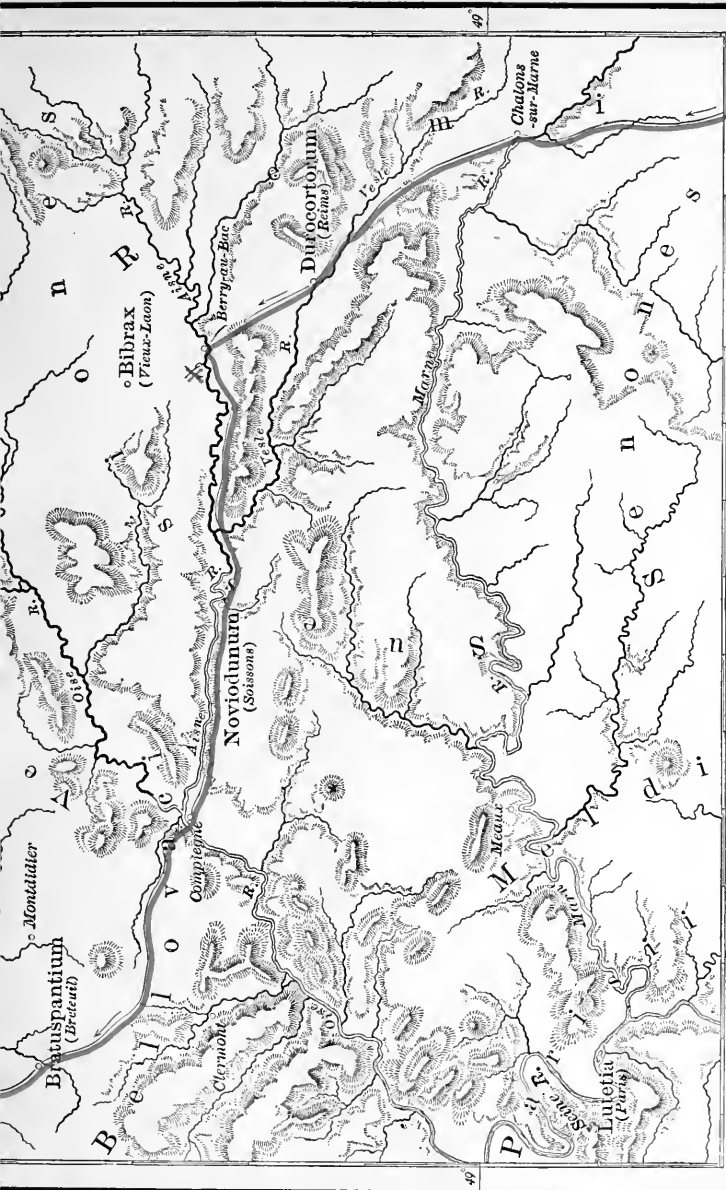

Longitude East from Greenwich

3°

4°

46°

49°

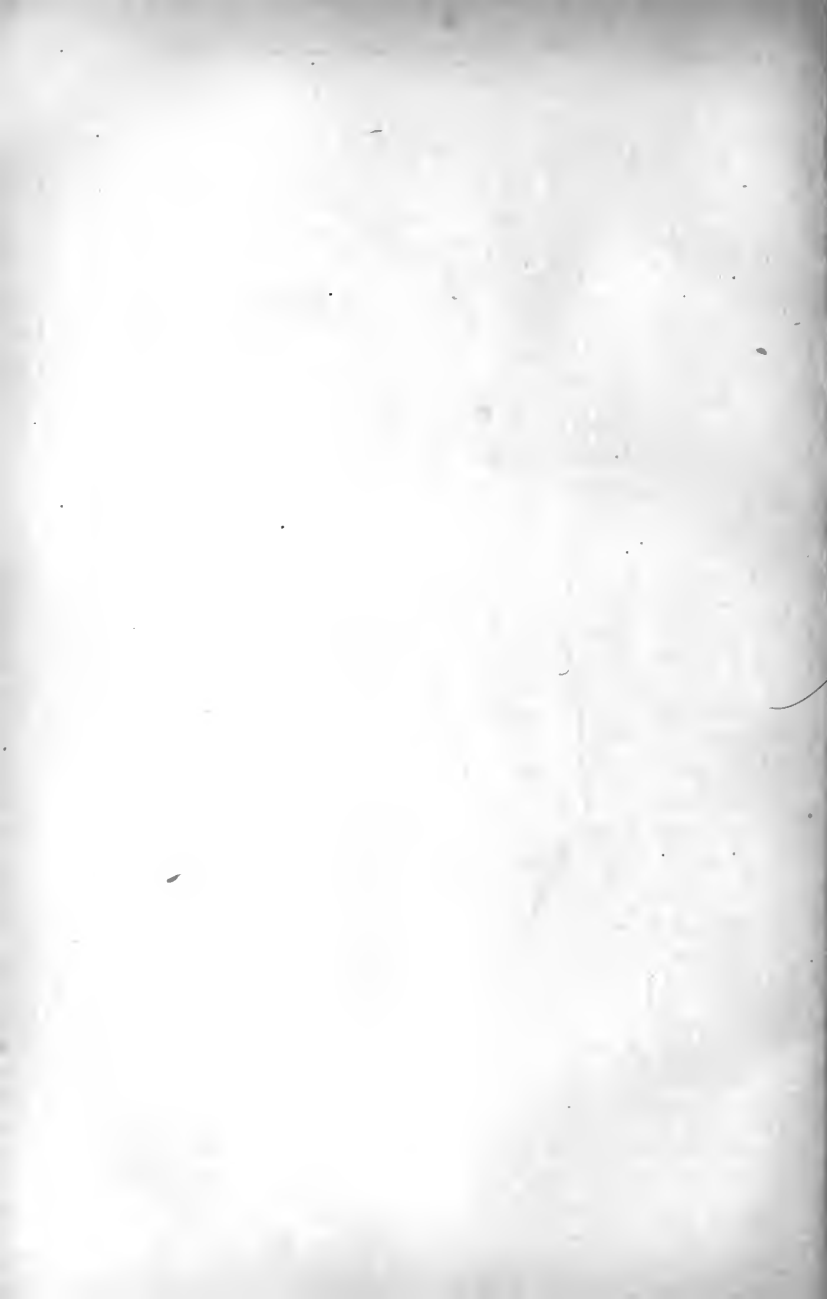



## BOOK II.

THE BELGIAN CONFEDERACY.—A league of the Belgian tribes is reported to Cæsar, who moves rapidly to the north, and accepts the submission of the Remi (1-3). Account of the Belgians and their tribes. Cæsar advances to the Axona, relieves the siege of Bibrax, the chief place of the Remi, and establishes a camp, strongly fortified (4-8). The Belgians attempt to cross the Axona, but are driven back, and pursued with great slaughter (9-11). Surrender of the Suessiones and Bellovaci: report of the Nervii, who wait to give battle across the Sabis (12-16). Position of the two forces: the Nervii attack with great fury, and throw the Romans into confusion, which is partly overcome by their admirable discipline (17-20). After various fortune, the Nervii assault the camp, which is saved, after a desperate struggle, by the personal address and courage of Cæsar (21-22). Labienus comes up with the tenth legion, and the tide is turned; the Nervii are crushed and almost exterminated (26-28). The Aduatuci: after sundry skirmishes they sue for peace; but renewing the fight after their surrender, are subdued, and upwards of 50,000 are sold as slaves (29-33). Meanwhile Crassus secures the submission of the coast population of the Veneti, etc.; Gaul appears wholly reduced to peace, and embassies are sent to Cæsar even from beyond the Rhine (34, 35).

CUM esset Cæsar in citeriøre Gallia [in hibernis], ita uti supra demonstravimus, crebri ad eum rumores afferebantur, litterisque item Labieni certior fiebat, omnes Belgas (quam tertiam esse Galliae partem dixeramus), contra populum Romanum conjurare, 5 obsidesque inter se dare. <sup>2</sup>Conjurandi has esse causas: primum quod vererentur ne, omni pacata Gallia, ad eos exercitus noster adduceretur; deinde quod ab nonnullis Gallis sollicitarentur,—partim qui, ut Germanos diutius in Gallia versari noluerant, ita populi 10 Romani exercitum hiemare atque inveterascere in Gallia moleste ferebant; <sup>3</sup>partim qui, mobilitate et levitate animi, novis imperiis studebant; ab nonnullis

etiam, quod in Gallia a potentioribus atque iis qui ad conducendos homines facultates habebant, vulgo regna occupabantur, qui minus facile eam rem imperio nostro consequi poterant.

5 2. His nuntiis litterisque commotus, Caesar duas legiones in citeriore Gallia novas conscripsit, et in ita aestate, in interiorem Galliam qui deduceret, Q. Pedium legatum misit. <sup>2</sup> Ipse, cum primum pabuli copia esse inciperet, ad exercitum venit. Dat negotium Se-  
 10 nonibus reliquisque Gallis, qui finitimi Belgis erant, uti ea quae apud eos gerantur cognoscant, seque de his rebus certiore faciant. <sup>3</sup> Hi constanter omnes nuntiaverunt manus cogi, exercitum in unum locum  
 15 ad eos proficisceretur. Re frumentaria comparata, castra movet, diebusque circiter quindecim ad fines Belgarum pervenit.

3. Eo cum de improviseo celeriusque omni opinione venisset, Remi, qui proximi Galliae ex Belgis sunt,  
 20 ad eum legatos Iccium et Andocumborium, primos civitatis, miserunt, qui dicerent: <sup>2</sup> 'Se suaque omnia in fidem atque in potestatem populi Romani permittere, neque se cum Belgis reliquis consensisse, neque contra populum Romanum conjurasse, paratos-  
 25 que esse et obsides dare et imperata facere et oppidis recipere et frumento ceterisque rebus juvare; <sup>3</sup> reliquos omnes Belgas in armis esse, Germanosque, qui cis Rhenum incolant, sese cum his conjunxisse, tantumque esse eorum omnium furorem, ut ne Suessiones  
 30 quidem, fratres consanguineosque suos, qui eodem jure et isdem legibus utantur, unum imperium unumque magistratum cum ipsis habeant, deterrere poterint quin cum his consentirent.'

4. Cum ab his quaereret, quae civitates quantaque  
 35 in armis essent, et quid in bello possent, sic reperiebat: <sup>2</sup> plerosque Belgas esse ortos ab Germanis,

Rhenumque antiquitus traductos propter loci fertilitatem ibi consedisse, Gallosque qui ea loca incolerent expulisse, solosque esse qui, patrum nostrorum memoria, omni Gallia vexata, Teutonos Cimbrosque intra fines suos ingredi prohibuerint; qua ex re fieri uti, earum rerum memoria, magnam sibi auctoritatem magnosque spiritus in re militari sumerent. <sup>3</sup> De numero eorum omnia se habere explorata Remi dicebant, propterea quod propinquitatibus adfinitatibusque conjuncti, quantam quisque multitudinem in communi Belgarum concilio ad id bellum pollicitus sit cognoverint. <sup>4</sup> Plurimum inter eos Bellovacos et virtute et auctoritate et hominum numero valere: hos posse conficere armata milia centum, pollicitos ex eo numero electa sexaginta, totiusque belli imperium sibi postulare. Suessiones suos esse finitimos: latissimos feracissimosque agros possidere. <sup>5</sup> Apud eos fuisse regem nostra etiam memoria Divitiacum, totius Galliae potentissimum, qui cum magnae partis harum regionum, tum etiam Britanniae imperium obtinuerit: nunc esse regem Galbam; ad hunc propter justitiam prudentiamque suam totius belli summam omnium voluntate deferri: <sup>6</sup> oppida habere numero XII, polliceri milia armata quinquaginta; totidem Nervios, qui maxime feri inter ipsos habeantur, longissimeque absint; quindecim milia Atrebates, Ambianos decem milia, Morinos XXV milia, Menapios VII milia; Caletos X milia; Velocasses et Veromandos totidem; Aduatucos decem et novem milia; Condrusos, Eburones, Caeroesos, Paemanos, qui uno nomine Germani appellantur, arbitrari ad XL milia.

5. Caesar Remos cohortatus liberaliterque oratione prosecutus, omnem senatum ad se convenire, principumque liberos obsides ad se adduci jussit. Quae omnia ab his diligenter ad diem facta sunt. <sup>2</sup> Ipse Divitiacum Haeduum magnopere cohortatus, docet

quanto opere rei publicae communisque salutis intersit manus hostium distineri, ne cum tanta multitudine uno tempore confligendum sit. <sup>3</sup> Id fieri posse, si suas copias Haedui in fines Bellovacorum introduxerint, et eorum agros populari coeperint. His mandatis, eum ab se dimittit. <sup>4</sup> Postquam omnes Belgarum copias in unum locum coactas ad se venire vidit, neque jam longe abesse ab iis quos miserat exploratoribus et ab Remis cognovit, flumen Axonam, quod est in extremis Remorum finibus, exercitum traducere maturavit, atque ibi castra posuit. <sup>5</sup> Quae res et latus unum castrorum ripis fluminis muniebat, et post eum quae essent tuta ab hostibus reddebat; et, commeatus ab Remis reliquisque civitatibus, ut sine periculo ad eum portari posset efficiebat. <sup>6</sup> In eo flumine pons erat. Ibi praesidium ponit, et in altera parte fluminis Q. Titurium Sabinum legatum cum sex cohortibus relinquit; castra in altitudinem pedum XII vallo fossaque duodeviginti pedum munire jubet.

6. Ab his castris oppidum Remorum nomine Bibrax aberat milia passuum octo. Id ex itinere magno impetu Belgae oppugnare coeperunt. Aegre eo die sustentatum est. <sup>2</sup> Gallorum eadem atque Belgarum oppugnatio est haec. Ubi circumjecta multitudine hominum totis moenibus undique in murum lapides jaci coepti sunt, murusque defensoribus nudatus est, testudine facta, portas succedunt murumque subruunt. <sup>3</sup> Quod tum facile fiebat. Nam cum tanta multitudo lapides ac tela conicerent, in muro consistendi potestas erat nulli. <sup>4</sup> Cum finem oppugnandi nox fecisset, Iccius Remus, summa nobilitate et gratia inter suos, qui tum oppido praefuerat, unus ex iis qui legati de pace ad Caesarem venerant, nuntium ad eum mittit: nisi subsidium sibi submittatur, sese diutius sustinere non posse.

7. Eo de media nocte Caesar, isdem ducibus usus

qui nuntii ab Iccio venerant, Numidas et Cretas sagittarios et funditores Baleares subsidio oppidanis mittit; quorum adventu et Remis cum spe defensionis studium propugnandi accessit, et hostibus eadem de causa spes potiundi oppidi discessit. <sup>2</sup> Itaque, paulisper apud <sup>5</sup> oppidum morati, agrosque Remorum depopulati, omnibus vicis aedificiisque quos adire poterant incensis, ad castra Caesaris omnibus copiis contenderunt, et ab milibus passuum minus duobus castra posuerunt; quae castra, ut fumo atque ignibus significabatur, amplius <sup>10</sup> milibus pasuum octo in latitudinem patebant.

8. Caesar primo, et propter multitudinem hostium et propter eximiam opinionem virtutis, proelio superedere statuit; cotidie tamen, equestribus proeliis, quid hostis virtute posset et quid nostri auderent periclitabatur. <sup>2</sup> Ubi nostros non esse inferiores intellexit, loco pro castris ad aciem instruendam natura opportuno atque idoneo, — quod is collis, ubi castra posita erant, paululum ex planicie editus, tantum adversus in latitudinem patebat quantum loci acies instructa occupare <sup>20</sup> poterat, atque ex utraque parte lateris dejectus habebat, et in frontem leniter fastigatus paulatim ad planiciem redibat, — <sup>3</sup> ab utroque latere ejus collis transversam fossam obduxit circiter passuum quadringentorum et ad extremas fossas castella constituit, ibique tormenta conlocavit, ne, cum aciem instruxisset, hostes (quod tantum multitudine poterant) ab lateribus pugnantibus suos circumvenire possent. <sup>4</sup> Hoc facto, duabus legionibus quas proxime conscripserat in castris relictis, ut, si quo opus esset, subsidio duci possent, reliquas <sup>30</sup> sex legiones pro castris in acie constituit. Hostes item suas copias ex castris eductas instruxerant.

9. Palus erat non magna inter nostrum atque hostium exercitum. Hanc si nostri transirent, hostes exspectabant; nostri autem, si ab illis initium transeundi fieret, ut impeditos adgrederentur, parati in armis

erant. <sup>2</sup> Interim proelio equestri inter duas acies contendebatur. Ubi neutri transeundi initium faciunt, secundiore equitum proelio nostris, Caesar suos in castra reduxit. Hostes protinus ex eo loco ad flumen  
 5 Axonam contenderunt, quod esse post nostra castra demonstratum est. <sup>3</sup> Ibi vadis repertis, partem suarum copiarum traducere conati sunt, eo consilio, ut, si possent, castellum, cui praeerat Q. Titurius legatus, expugnarent, pontemque interscinderent; si minus  
 10 potuissent, agros Remorum popularentur, qui magno nobis usui ad bellum gerendum erant, commeatuque nostros prohiberent.

10. *Caesar*, certior factus ab Titurio, omnem equitatum et levis armaturae Numidas, funditores sagittariosque pontem traducit, atque ad eos contendit.

<sup>2</sup> Acriter in eo loco pugnatum est. Hostes impeditos nostri in flumine adgressi, magnum eorum numerum occiderunt: per eorum corpora reliquos, audacissime transire conantes, multitudine telorum repulerunt;  
 20 primos, qui transierant, equitatu circumventos interfecerunt. <sup>3</sup> Hostes ubi et de expugnando oppido et de flumine transeundo spem se fefellisse intellexerunt, neque nostros in locum iniquiorem progredi pugnandi causa viderunt, atque ipsos res frumentaria deficere  
 25 coepit, concilio convocato, constituerunt optimum esse domum suam quemque reverti, et, quorum in fines primum Romani exercitum introduxissent, ad eos defendendos undique convenirent, ut potius in suis quam in alienis finibus decertarent, et domesticis  
 30 copiis rei frumentariae uterentur. <sup>4</sup> Ad eam sententiam cum reliquis causis haec quoque ratio eos deduxit, quod Divitiacum atque Haeduos finibus Bellovacorum adpropinquare cognoverant. His persuaderi ut diutius morarentur, neque suis auxilium ferrent,  
 35 non poterat.

11. Ea re constituta, secunda vigilia magno cum

strepitu ac tumultu castris egressi, nullo certo ordine neque imperio, cum sibi quisque primum itineris locum peteret et domum pervenire properaret, fecerunt ut consimilis fugae profectio videretur. <sup>2</sup>Hac re statim Caesar per speculatores cognita, insidias veritus, quod <sup>5</sup>qua de causa discederent nondum perspexerat, exercitum, equitatumque castris continuit. <sup>3</sup>Prima luce, confirmata re ab exploratoribus, omnem equitatum qui novissimum agmen moraretur praemisit. His Q. Pedium et L. Aurunculeium Cottam legatos praefecit; <sup>10</sup>T. Labienum legatum cum legionibus tribus subsequi jussit. <sup>4</sup>Hi, novissimos adorti, et multa milia passuum prosecuti, magnam multitudinem eorum fugientium conciderunt; cum ab extremo agmine, ad quos ventum erat, consisterent, fortiterque impetum nostrorum <sup>15</sup>militum sustinerent, priores, quod abesse a periculo viderentur, neque ulla necessitate neque imperio continerentur, exaudito clamore, perturbatis ordinibus, omnes in fuga sibi praesidium ponerent. <sup>5</sup>Ita sine ullo periculo tantam eorum multitudinem nostri inter- <sup>20</sup>fecerunt, quantum fuit diei spatium; sub occasumque solis destiterunt, seque in castra, ut erat imperatum, receperunt.

12. Postridie ejus diei Caesar, priusquam se hostes ex terrore ac fuga reciperent, in fines Suessionum, <sup>25</sup>qui proximi Remis erant, exercitum duxit, et magno itinere [confecto] ad oppidum Noviodunum contendit. <sup>2</sup>Id ex itinere oppugnare conatus, quod vacuum ab defensoribus esse audiebat, propter latitudinem fossae murique altitudinem, paucis defendentibus, expugnare <sup>30</sup>non potuit. <sup>3</sup>Castris munitis, vineas agere quaeque ad oppugnandum usui erant comparare coepit. Interim omnis ex fuga Suessionum multitudo in oppidum proxima nocte convenit. <sup>4</sup>Celeriter vineis ad oppidum actis, aggere jacto turribusque constitutis, magnitudine <sup>35</sup>operum, quae neque viderant ante Galli neque audie-

rant, et celeritate Romanorum permoti, legatos ad Caesarem de deditioe mittunt, et petentibus Remis, ut conservarentur impetrant.

13. Caesar obsidibus acceptis primis civitatis, atque  
 5 ipsius Galbae regis duobus filiis, armisque omnibus ex oppido traditis, in deditioem Suessiones accepit, exercitumque in Bellovacos ducit. <sup>2</sup>Qui cum se suaque omnia in oppidum Bratuspantium contulissent, atque ab eo oppido Caesar cum exercitu circiter milia pas-  
 10 suum quinque abesset, omnes majores natu, ex oppido egressi, manus ad Caesarem tendere, et voce significare coeperunt sese in ejus fidem ac potestatem venire, neque contra populum Romanum armis contendere. <sup>3</sup>Item, cum ad oppidum accessisset, castraque ibi  
 15 poneret, pueri mulieresque ex muro passis manibus suo more pacem ab Romanis petierunt.

14. Pro his Divitiacus — nam post discessum Belgarum, dimissis Haeduum copiis, ad eum reverterat — facit verba: ‘Bellovacos omni tempore in fide atque  
 20 amicitia civitatis Haeduae fuisse: <sup>2</sup>impulsos a suis principibus, qui dicerent Haeduos, ab Caesare in servitutem redactos, omnes indignitates contumeliasque perferre, et ab Haeduis defecisse, et populo Romano bellum intulisse. <sup>3</sup>Qui ejus consilii principes fuissent  
 25 quod intellegerent quantam calamitatem civitati intulissent, in Britanniam profugisse. <sup>4</sup>Petere non solum Bellovacos, sed etiam pro his Haeduos, ut sua clementia ac mansuetudine in eos utatur. <sup>5</sup>Quod si fecerit, Haeduum auctoritatem apud omnes Belgas amplifi-  
 30 caturum, quorum auxiliis atque opibus, si qua bella inciderint, sustentare consuerint.’

15. Caesar honoris Divitiaci atque Haeduum causa sese eos in fidem recepturum et conservaturum dixit; quod erat civitas magna inter Belgas auctoritate, atque  
 35 hominum multitudine praestabat, sexcentos obsides poposcit. <sup>2</sup>His traditis, omnibusque armis ex oppido



conlatis, ab eo loco in fines Ambianorum pervenit, qui se suaque omnia sine mora dederunt. Eorum fines Nervii attingebant; quorum de natura moribusque Caesar cum quaereret, sic reperiebat: <sup>3</sup>Nullum aditum esse ad eos mercatoribus; nihil pati vini reli- 5 quarumque rerum inferri, quod iis rebus relanguescere animos [eorum] et remitti virtutem existimarent: <sup>4</sup>esse homines feros magnaue virtutis; increpitare atque incusare reliquos Belgas, qui se populo Romano dedidissent patriamque virtutem projecissent; confirmare <sup>10</sup>sese neque legatos missuros, neque ullam condicionem pacis accepturos.

16. Cum per eorum fines triduum iter fecisset, inveniebat ex captivis Sabim flumen ab castris suis non amplius milia passuum X abesse: <sup>2</sup>trans id flumen <sup>15</sup>omnes Nervios consedissee, adventumque ibi Romanorum exspectare, una cum Atrebatis et Veromanduis, finitimis suis (nam his utrisque persuaserant, uti eandem belli fortunam experirentur); <sup>3</sup>exspectari etiam ab his Aduatucorum copias atque esse in itinere; mulie- <sup>20</sup>res quique per aetatem ad pugnam inutiles viderentur in eum locum conjecisse, quo propter paludes exercitui aditus non esset.

17. His rebus cognitis, exploratores centurionesque praemittit, qui locum idoneum castris deligant. Cum <sup>25</sup>ex dediticiis Belgis reliquisque Gallis complures Caesarem secuti una iter facerent, quidam ex his, ut postea ex captivis cognitum est, eorum dierum consuetudine itineris nostri exercitus perspecta, nocte ad Nervios pervenerunt; <sup>2</sup>atque his demonstrarunt inter singulas <sup>30</sup>legiones impedimentorum magnum numerum intercedere, neque esse quicquam negotii, cum prima legio in castra venisset, reliquaeque legiones magnum spatium abessent, hanc sub sarcinis adoriri; qua pulsa impedimentisque direptis, futurum ut reliquae contra <sup>35</sup>consistere non auderent. <sup>3</sup>Adjuvabat etiam eorum

consilium qui rem deferebant, quod Nervii antiquitus, cum equitatu nihil possent (neque enim ad hoc tempus ei rei student, sed, quicquid possunt, pedestribus valent copiis), <sup>4</sup> quo facilius finitimorum equitatum, si <sup>5</sup> praedandi causa ad eos venissent, impedirent, teneris arboribus incisus atque inflexis, crebrisque in latitudinem ramis enatis, et rubis sentibusque interjectis, effecerant ut instar muri hae sepes munimenta praeberent, quo non modo non intrari, sed ne perspici quidem posset. <sup>10</sup> His rebus cum iter agminis nostri impediretur, non omittendum sibi consilium Nervii existimaverunt.

18. Loci natura erat haec, quem locum nostri castris delegerant. Collis ab summo aequaliter declivis ad flumen Sabim, quod supra nominavimus, vergebat. <sup>15</sup> <sup>2</sup> Ab eo flumine pari adclivitate collis nascebatur adversus huic et contrarius, passus circiter ducentos infimus apertus, ab superiore parte silvestris, ut non facile introrsus perspici posset. <sup>3</sup> Intra eas silvas hostes in occulto sese continebant; in aperto loco secundum flumen paucae stationes equitum videbantur. <sup>20</sup> Fluminis erat altitudo pedum circiter trium.

19. Caesar equitatu praemisso subsequebatur omnibus copiis; sed ratio ordoque agminis aliter se habebat ac Belgae ad Nervios detulerant. <sup>2</sup> Nam quod ad <sup>25</sup> hostis adpropinquabat, consuetudine sua Caesar sex legiones expeditas ducebat; post eas totius exercitus impedimenta conlocarat; inde duae legiones, quae proxume conscriptae erant, totum agmen claudebant, praesidioque impedimentis erant. <sup>3</sup> Equites nostri, cum <sup>30</sup> funditoribus sagittariisque flumen transgressi, cum hostium equitatu proelium commiserunt. <sup>4</sup> Cum se illi identidem in silvas ad suos reciperent, ac rursus ex silva in nostros impetum facerent, neque nostri longius quam quem ad finem porrecta loca aperta <sup>35</sup> pertinebant cedentes insequi auderent, interim legiones sex, quae primae venerant, opere dimenso, castra

munire coeperunt. <sup>5</sup> Ubi prima impedimenta nostri exercitus ab iis qui in silvis abditi latebant visa sunt, quod tempus inter eos committendi proelii convenerat, ut intra silvas aciem ordinesque constituerant atque ipsi sese confirmaverant, subito omnibus copiis pro- 5  
volaverunt, impetumque in nostros equites fecerunt. <sup>6</sup> His facile pulsus ac proturbatis, incredibili celeritate ad flumen decucurrerunt, ut paene uno tempore et ad silvas et in flumine et jam in manibus nostris hostes viderentur. Eadem autem celeritate adverso colle ad 10  
nostra castra, atque eos qui in opere occupati erant, contenderunt.

20. Caesari omnia uno tempore erant agenda: vexillum proponendum (quod erat insigne, cum ad arma concurrere oporteret), signum tuba dandum, ab opere 15  
revocandi milites, qui paulo longius aggeris petendi causa processerant arcessendi, acies instruenda, milites cohortandi, signum dandum. Quarum rerum magnam partem temporis brevitatis et successus hostium impedi-  
bat. <sup>2</sup> His difficultatibus duae res erant sub- 20  
sidio, — scientia atque usus militum, quod superioribus proeliis exercitati, quid fieri oporteret, non minus commode ipsi sibi praescribere quam ab aliis doceri poterant; et quod ab opere singulisque legionibus singulos legatos Caesar discedere nisi munitis castris 25  
vetuerat. <sup>3</sup> Hi, propter propinquitatem et celeritatem hostium, nihil jam Caesaris imperium exspectabant, sed per se quae videbantur administrabant.

21. Caesar, necessariis rebus imperatis, ad cohortandos milites quam in partem fors obtulit decucurrit, 30  
et ad legionem decumam devenit. <sup>2</sup> Milites non longiore oratione cohortatus, quam uti suae pristinae virtutis memoriam retinerent, neu perturbarentur animo, hostiumque impetum fortiter sustinerent, quod non longius hostes aberant quam quo telum adici 35  
posset, proelii committendi signum dedit. <sup>3</sup> Atque in

alteram partem item cohortandi causa profectus, pugnantibus occurrit. Temporis tanta fuit exiguitas, hostiumque tam paratus ad dimicandum animus, ut non modo ad insignia adcommo-  
 5 galeas induendas scutisque tegimenta detrudenda tempus defuerit. <sup>4</sup>Quam quisque ab opere in partem casu devenit, quaeque prima signa conspexit, ad haec constitit, ne in quaerendis suis pugnandi tempus dimitteret.

10 22. Instructo exercitu, magis ut loci natura dejectusque collis et necessitas temporis, quam ut rei militaris ratio atque ordo postulabat, cum diversis legionibus aliae alia in parte hostibus resisterent, sepibusque  
 15 densissimis (ut ante demonstravimus) interjectis prospectus impediretur, neque certa subsidia conlocari, neque quid in quaque parte opus esset provideri, neque ab uno omnia imperia administrari poterant. Itaque, in tanta rerum iniquitate, fortunae quoque eventus varii sequebantur.

20 23. Legionis nonae et decimae milites, ut in sinistra parte acie constiterant, pilis emissis, cursu ac lassitudine exanimatos vulneribusque confectos Atrebates — nam his ea pars obvenerat — celeriter ex loco superiore in flumen compulerunt, et transire conantes  
 25 insecuti, gladiis magnam partem eorum impeditam interfecerunt. <sup>2</sup>Ipsi transire flumen non dubitaverunt, et in locum iniquum progressi, rursus resistentes hostes redintegrato proelio in fugam conjecerunt. <sup>3</sup>Item alia in parte diversae duae legiones, undecima et  
 30 octava, profligatis Veromanduis, quibuscum erant congressi, ex loco superiore in ipsis fluminis ripis proeliabantur. <sup>4</sup>At totis fere a fronte et ab sinistra parte nudatis castris, quom in dextro cornu legio duodecima et non magno ab ea intervallo septima con-  
 35 stitisset, omnes Nervii confertissimo agmine, duce Boduognato, qui summam imperii tenebat, ad eum

locum contenderunt ; quorum pars aperto latere legiones circumvenire, pars summum castrorum locum petere coepit.

24. Eodem tempore equites nostri levisque armaturae pedites, qui cum iis una fuerant, quos primo 5 hostium impetu pulsos dixeram, cum se in castra recipent, adversis hostibus occurrebant, ac rursus aliam in partem fugam petebant ; <sup>2</sup>et calones, qui ab decumana porta ac summo jugo collis nostros victores flumen transisse conspexerant, praedandi causa egressi, <sup>10</sup> cum respexissent et hostes in nostris castris versari vidissent, praecipites fugae sese mandabant. <sup>3</sup>Simul eorum, qui cum impedimentis veniebant, clamor fremitusque oriebatur, aliique aliam in partem perterriti ferebantur. <sup>4</sup>Quibus omnibus rebus permoti equites <sup>15</sup> Treveri, quorum inter Gallos virtutis opinio est singularis, qui auxilii causa ab civitate ad Caesarem missi venerant, cum multitudine hostium castra compleri, legiones premi et paene circumventas teneri, calones, equites, funditores, Numidas diversos dissipatosque in <sup>20</sup> omnes partes fugere vidissent, desperatis nostris rebus, domum contenderunt ; Romanos pulsos superatosque, castris impedimentisque eorum hostes potitos, civitati renuntiaverunt.

25. Caesar ab decimae legionis cohortatione ad <sup>25</sup> dextrum cornu profectus, ubi suos urgeri, signisque in unum locum conlatis, duodecimae legionis confertos milites sibi ipsos ad pugnam esse impedimento vidit, — <sup>2</sup>quartae cohortis omnibus centurionibus occisis, signiferoque interfecto, signo amisso, reliquarum cohortium omnibus fere centurionibus aut vulneratis aut <sup>30</sup> occisis, in his primipilo P. Sextio Baculo, fortissimo viro, multis gravibusque vulneribus confecto, ut jam se sustinere non posset ; <sup>3</sup>reliquos esse tardiores, et nonnullos ab novissimis deserto proelio excedere ac <sup>35</sup> tela vitare, hostis neque a fronte ex inferiore loco

subeuntes intermittere, et ab utroque latere instare, et rem esse in angusto vidit, neque ullum esse subsidium quod summitti posset, — <sup>4</sup>scuto ab novissimis uni militi detracto, quod ipse eo sine scuto venerat, in primam  
5 aciem processit; centurionibusque nominatim appellatis, reliquos cohortatus, milites signa inferre et manipulos laxare jussit, quo facilius gladiis uti possent. <sup>5</sup>Cujus adventu spe inlata militibus, ac redintegrato animo, cum pro se quisque in conspectu imperatoris  
10 etiam in extremis suis rebus operam navare cuperet, paulum hostium impetus tardatus est.

26. Caesar, cum septimam legionem, quae juxta constiterat, item urgeri ab hoste vidisset, tribunos militum monuit, ut paulatim sese legiones conjungerent,  
15 et conversa signa in hostes inferrent. <sup>2</sup>Quo facto, cum alius alii subsidium ferret, neque timerent ne aversi ab hoste circumvenirentur, audacius resistere ac fortius pugnare coeperunt. <sup>3</sup>Interim milites legionum duarum, quae in novissimo agmine praesidio  
20 impedimentis fuerant, proelio nuntiato, cursu incitato, in summo colle ab hostibus conspiciebantur; <sup>4</sup>et T. Labienus, castris hostium potitus, et ex loco superiore quae res in nostris castris gererentur conspicatus, decimam legionem subsidio nostris misit. <sup>5</sup>Qui, cum  
25 ex equitum et calonum fuga, quo in loco res esset, quantoque in periculo et castra et legiones et imperator versaretur, cognovissent, nihil ad celeritatem sibi reliqui fecerunt.

27. Horum adventu tanta rerum commutatio est  
30 facta, ut nostri, etiam qui vulneribus confecti procu- buissent, scutis innixi proelium redintegrarent; tum calones, perterritos hostes conspicati, etiam inermes armatis occurrerent; equites vero, ut turpitudinem fugae virtute delerent, omnibus in locis [pugnant, quo]  
35 se legionariis militibus praeferrent. <sup>2</sup>At hostes etiam in extrema spe salutis tantam virtutem praestiterunt,

ut, cum primi eorum cecidissent, proximi jacentibus insisterent, atque ex eorum corporibus pugnarent; <sup>3</sup>his dejectis, et cocervatis cadaveribus, qui superessent ut ex tumulo tela in nostros conicerent, et pila intercepta remitterent: ut non nequiquam tantae virtutis homines judicari deberet ausos esse transire latissimum flumen, ascendere altissimas ripas, subire iniquissimum locum; quae facilia ex difficillimis animi magnitudo redegerat.

28. Hoc proelio facto, et prope ad interneccionem gente ac nomine Nerviorum redacto, majores natu, quos una cum pueris mulieribusque in aestuaria ac paludes coniectos dixeramus, hac pugna nuntiata, cum victoribus nihil impeditum, victis nihil tutum arbitrarentur, omnium qui supererant consensu, legatos ad Caesarem miserunt, seque ei dediderunt; <sup>2</sup>et in commemoranda civitatis calamitate, ex sexcentis ad tres senatores, ex hominum milibus LX vix ad quingentos, qui arma ferre possent, sese redactos esse dixerunt. <sup>3</sup>Quos Caesar, ut in miseros ac supplices usus misericordia videretur, diligentissime conservavit, suisque finibus atque oppidis uti jussit, et finitimis imperavit, ut ab injuria et maleficio se suosque prohiberent.

29. Aduatuci, de quibus supra scripsimus, cum omnibus copiis auxilio Nervii venirent, hac pugna nuntiata, ex itinere domum reverterunt; cunctis oppidis castellisque desertis, sua omnia in unum oppidum egregie natura munitum contulerunt. <sup>2</sup>Quod cum ex omnibus in circuitu partibus altissimas rupes despectusque haberet, una ex parte leniter adclivis aditus in latitudinem non amplius ducentorum pedum relinquebatur; quem locum duplici altissimo muro munierant: tum magni ponderis saxa et praeacutas trabes in muro conlocabant. <sup>3</sup>Ipsi erant ex Cimbris Teutonisque prognati, qui, cum iter in provinciam nostram atque

Italiam facerent, iis impedimentis, quae secum agere ac portare non poterant, citra flumen Rhenum depositis, custodiam ex suis ac praesidium sex milia hominum una reliquerunt. <sup>4</sup> Hi post eorum obitum multos annos a finitimis exagitati, cum alias bellum inferrent, alias inlatum defenderent, consensu eorum omnium pace facta, hunc sibi domicilio locum delegerunt.

30. Ac, primo adventu exercitus nostri, crebras ex oppido excursions faciebant, parvulisque proeliis cum nostris contendebant; postea vallo pedum XII in circuitu XV milium crebrisque castellis circummuniti, oppido sese continebant. <sup>2</sup> Ubi vineis actis, aggere exstructo, turrim procul constitui viderunt, primum inridere ex muro, atque increpitare vocibus, quod <sup>3</sup> quibusnam manibus aut quibus viribus praesertim homines tantulae staturae — nam plerumque hominibus Gallis prae magnitudine corporum suorum brevitudo nostra contemptui est — tanti oneris turrim in muro sese conlocare confiderent?

31. Ubi vero moveri et adpropinquare moenibus viderunt, nova atque inusitata specie commoti, legatos ad Caesarem de pace miserunt, qui ad hunc modum locuti: <sup>2</sup> 'Non existimare Romanos sine ope divina bellum gerere, qui tantae altitudinis machinationes tanta celeritate promovere possent; se suaque omnia eorum potestati permittere' dixerunt. <sup>3</sup> 'Unum petere ac deprecari: si forte pro sua clementia ac mansuetudine, quam ipsi ab aliis audirent, statuisset Aduaticos esse conservandos, ne se armis despoliaret.

<sup>4</sup> Sibi omnes fere finitimos esse inimicos ac suae virtuti invidere; a quibus se defendere traditis armis non possent. <sup>5</sup> Sibi praestare, si in eum casum deducerentur, quamvis fortunam a populo Romano pati, quam ab his per cruciatum interfici, inter quos dominari consuessent.'



32. Ad haec Caesar respondit: 'Se magis consuetudine sua quam merito eorum civitatem conservaturum, si prius quam murum aries attigisset se dedidissent: sed deditiois nullam esse condicionem nisi armis traditis. <sup>2</sup>Se id quod in Nerviiis fecisset facturum, finitimisque imperaturum, ne quam dediticiis populi Romani injuriam inferrent.' Re nuntiata ad suos, quae imperarentur facere dixerunt. <sup>3</sup>Armorum magna multitudine de muro in fossam, quae erat ante oppidum, jacta, sic ut prope summam muri aggerisque altitudinem acervi armorum adaequarent, et tamen circiter parte tertia, ut postea perspectum est, celata atque in oppido retenta, portis patefactis, eo die pace sunt usi.

33. Sub vesperum Caesar portas claudi militesque ex oppido exire jussit, ne quam noctu oppidani ab militibus injuriam acciperent. Illi, ante inito (ut intellectum est) consilio, quod deditioe facta nostros praesidia deducturos aut denique indiligentius servaturos crediderant, — <sup>2</sup>partim cum iis quae retinuerant et celaverant armis, partim scutis ex cortice factis aut viminibus intextis, quae subito, ut temporis exiguitas postulabat, pellibus induxerant, — tertia vigilia, qua minime arduus ad nostras munitiones ascensus videbatur, omnibus copiis repentino ex oppido eruptionem fecerunt. <sup>3</sup>Celeriter, ut ante Caesar imperarat, ignibus significatione facta, ex proximis castellis eo concursus est, pugnatumque ab hostibus ita acriter est, ut a viris fortibus in extrema spe salutis, iniquo loco, contra eos qui ex vallo turribusque tela jacerent, pugnari debuit, cum in una virtute omnis spes salutis consisteret. <sup>4</sup>Occisis ad hominum milibus quattuor, reliqui in oppidum rejecti sunt. Postridie ejus diei refractis portis, cum jam defenderet nemo, atque intromissis militibus nostris, sectionem ejus oppidi universam Caesar vendidit. Ab iis qui emerant, capitum

numerus ad eum relatus est milium quinquaginta trium.

34. Eodem tempore a P. Crasso, quem cum legione una miserat ad Venetos, Unellos, Osismos, Curiosolitas, Esuvios, Aulercos, Redones, quae sunt maritimae civitates Oceanumque attingunt, certior factus est omnes eas civitates in dicionem potestatemque populi Romani esse redactas.

35. His rebus gestis, omni Gallia pacata, tanta hujus belli ad barbaros opinio perlata est, uti ab iis nationibus, quae trans Rhenum incolerent, mitterentur legati ad Caesarem, qui se obsides daturas, imperata facturas pollicerentur. <sup>2</sup>Quas legationes Caesar, quod in Italiam Illyricumque properabat, inita proxima aestate ad se reverti jussit. <sup>3</sup>Ipsa in Carnutes, Andes Turonesque, quae civitates propinquae his locis erant, ubi bellum gesserat, legionibus in hibernacula deductis, in Italiam profectus est. <sup>4</sup>Ob easque res ex litteris Caesaris dies quindecim supplicatio decreta est, quod ante id tempus accidit nulli.

## BOOK III.

ALPINE CAMPAIGN.—A garrison, under the command of Servius Galba, had been set to guard the passes of the Upper Rhone, but is threatened by a formidable force, and brought into extreme danger (1-3). After sustaining an attack of some six hours, the garrison make a sudden sally, drive back the enemy, destroy the neighboring villages, and retire to the lower country, south of Lake Geneva, for the winter (4-6).

NAVAL CAMPAIGN.—The sea-faring tribes of Brittany form a strong league, under lead of the Veneti, and demand back their hostages from Crassus (7, 8). Cæsar prepares a fleet upon the Loire; the enemy fortify themselves on the coast. Labienus is sent to guard the north, and Crassus to the south; and Brutus is put in command of the Roman fleet (9-11). Situation of the Venetian strongholds; description of the fleets (12, 13). Engagement of the fleets: the enemies' sailyards are cut away, and their ships dispersed; they surrender, their leaders are slain, and the rest sold as slaves (14-16). Meanwhile Sabinus, who is sent among the Unelli, on the Channel, a little further north, is attacked by them, but drives them back with great slaughter, and compels their surrender (17-19).

SOUTHERN GAUL.—Crassus, in Aquitania, after some skirmishing, is threatened by a strong league, relying chiefly on the *soldurii*; but attacks them in their camp, and secures the conquest of the whole region (20-27). Cæsar, meanwhile, proceeds against the Morini, &c., along the coast of Flanders; and, as they retire to their marshes, falls back to winter quarters near the mouth of the Seine (28, 29).

CUM in Italiam proficisceretur Caesar, Servium Galbam, cum legione duodecima et parte equitatus, in Nantuatis, Veragros Sedunosque misit, qui ab finibus Allobrogum et lacu Lemanno et flumine Rhodano ad summas Alpes pertinent. <sup>2</sup>Causa mittendi fuit, quod iter per Alpes, quo magno cum periculo magnisque cum portoriis mercatores ire consuerant,

pateferi volebat. Huic permisit, si opus esse arbitraretur, uti in his locis legionem hiemandi causa conlocaret. <sup>3</sup>Galba, secundis aliquot proeliis factis, castellisque compluribus eorum expugnatis, missis ad  
5 eum undique legatis, obsidibusque datis et pace facta, constituit cohortes duas in Nantuatibus conlocare, et ipse cum reliquis ejus legionis cohortibus in vico Veragrorum, qui appellatur Octodurus, hiemare; <sup>4</sup>qui vicus, positus in valle, non magna adjecta planicie,  
10 altissimis montibus undique continetur. <sup>5</sup>Cum hic in duas partes flumine divideretur, alteram partem ejus vici Gallis ad hiemandum concessit, alteram vacuum ab his relictam cohortibus adtribuit. Eum locum vallo fossaque munivit.

15 2. Cum dies hibernorum complures transissent, frumentumque eo comportari jussisset, subito per exploratores certior factus est ex ea parte vici, quam Gallis concesserat, omnes noctu discessisse, montesque, qui impenderent, a maxima multitudine Sedunorum et  
20 Veragrorum teneri. <sup>2</sup>Id aliquot de causis acciderat, ut subito Galli belli renovandi legionisque opprimendae consilium caperent: primum, quod legionem — neque cam plenissimam, detractis cohortibus duabus et compluribus singulatim, qui commeatus petendi causa  
25 missi erant — propter paucitatem despiciebant; <sup>3</sup>tum etiam quod propter iniquitatem loci, cum ipsi ex montibus in vallem decurrerent et tela conicerent, ne primum quidem posse impetum suum sustineri existimabant.  
<sup>4</sup>Accedebat, quod suos ab se liberos abstractos obsi-  
30 dum nomine dolebant, et Romanos non solum itinerum causa, sed etiam perpetuae possessionis culmina Alpium occupare conari, et ea loca finitimae provinciae adjungere sibi persuasum habebant.

3. His nuntiis acceptis, Galba, cum neque opus  
35 hibernorum munitionesque plene essent perfectae, neque de frumento reliquoque commeatu satis esset

provisum, quod deditioe facta obsidibusque acceptis nihil de bello timendum existimaverat, consilio celeriter convocato, sententias exquirere coepit. <sup>2</sup> Quo in consilio, cum tantum repentini periculi praeter opinionem accidisset, ac jam omnia fere superiora loca multitudine armatorum completa conspicerentur, neque subsidio veniri neque commeatus supportari interclusis itineribus possent, <sup>3</sup> prope jam desperata salute, nonnullae hujusmodi sententiae dicebantur, ut impedimentis relictis, eruptione facta, isdem itineribus quibus <sup>10</sup> eo pervenissent, ad salutem contenderent. <sup>4</sup> Majori tamen parti placuit, hoc reservato ad extremum consilio, interim rei eventum experiri, et castra defendere.

4. Brevi spatio interjecto, vix ut iis rebus quas constituissent conlocandis atque administrandis tempus <sup>15</sup> daretur, hostes ex omnibus partibus signo dato decurrere, lapides gaesaque in vallum conicere. <sup>2</sup> Nostri primo integris viribus fortiter repugnare, neque ullum frustra telum ex loco superiore mittere, ut quaeque pars castrorum nudata defensoribus premi videbatur, <sup>20</sup> eo occurrere et auxilium ferre; sed hoc superari, quod diuturnitate pugnae hostes defessi proelio excedebant, alii integris viribus succedebant: <sup>3</sup> quarum rerum a nostris propter paucitatem fieri nihil poterat, ac non modo defesso ex pugna excedendi, sed ne saucio qui- <sup>25</sup> dem ejus loci, ubi constiterat, relinquendi ac sui recipiendi facultas dabatur.

5. Cum jam amplius horis sex continenter pugnetur, ac non solum vires sed etiam tela nostros deficerent, atque hostes acrius instarent, languidioribusque <sup>30</sup> nostris vallum scindere et fossas complere coepissent, resque esset jam ad extremum perducta casum, <sup>2</sup> P. Sextius Baculus, primi pili centurio, quem Nervico proelio compluribus confectum vulneribus diximus, et item Gaius Volusenus, tribunus militum, vir et consilii <sup>35</sup> magni et virtutis, ad Galbam adcurrunt, atque unam

esse spem salutis docent, si eruptione facta extremum auxilium experirentur. <sup>3</sup>Itaque, convocatis centurionibus, celeriter milites certiores facit, paulisper intermitterent proelium, ac tantummodo tela missa exciperent seque ex labore reficerent; post, dato signo, ex castris erumperent, atque omnem spem salutis in virtute ponerent.

6. Quod jussi sunt faciunt, ac subito omnibus portis eruptione facta, neque cognoscendi quid fieret, neque sui colligendi hostibus facultatem relinquunt. <sup>2</sup>Ita commutata fortuna, eos qui in spem potiundorum castrorum venerant undique circumventos interficiunt; et ex hominum milibus amplius triginta, quem numerum barbarorum ad castra venisse constabat, plus <sup>15</sup> tertia parte interfecta, reliquos perterritos in fugam coniciunt, ac ne in locis quidem superioribus consistere patiuntur. <sup>3</sup>Sic omnibus hostium copiis fuis, armisque exutis, se in castra munitionesque suas recipiunt. <sup>4</sup>Quo proelio facto, quod saepius fortunam temptare <sup>20</sup> Galba nolebat, atque alio se in hiberna consilio venisse meminerat, aliis occurrisse rebus viderat, maxime frumenti commeatusque inopia permotus, postero die, omnibus ejus vici aedificiis incensis, in provinciam reverti contendit, ac nullo hoste prohibente aut iter <sup>25</sup> demorante, incolumem legionem in Nantuatis, inde in Allobroges perduxit, ibique hiemavit.

7. His rebus gestis, cum omnibus de causis Caesar pacatam Galliam existimaret, superatis Belgis, expulsis Germanis, victis in Alpibus Sedunis, atque ita in <sup>30</sup> hieme in Illyricum profectus esset, quod eas quoque nationes adire et regiones cognoscere volebat, subitum bellum in Gallia coörtum est. <sup>2</sup>Ejus belli haec fuit causa. P. Crassus adulescens cum legione septima proximus mare Oceanum in Andibus hiemaratus. <sup>3</sup>Is, <sup>35</sup> quod in his locis inopia frumenti erat, praefectos tribunosque militum complures in finitimas civitates

frumenti causa dimisit; quo in numero erat T. Terasidius missus in Esuvios, M. Trebius Gallus in Curiosolitas, Q. Velanius cum T. Silio in Venetos.

8. Hujus est civitatis longe amplissima auctoritas omnis orae maritimae regionum earum, quod et naves 5 habent Veneti plurimas, quibus in Britanniam navigare consuerunt, et scientia atque usu nauticarum rerum reliquos antecedunt, et in magno impetu maris atque aperto paucis portibus interjectis, quos tenent ipsi, omnes fere, qui eo mari uti consuerunt, habent 10 vectigales. <sup>2</sup> Ab his fit initium retinendi Siliique atque Velanii, quod per eos suos se obsides, quos Crasso dedissent, reciperatos existimabant. <sup>3</sup> Horum auctoritate finitimi adducti (ut sunt Gallorum subita et repentina consilia), eadem de causa Trebium Terra- 15 sidiumque retinent; et celeriter missis legatis, per suos principes inter se conjurant, nihil nisi communi consilio acturos, eundemque omnis fortunae exitum esse laturos; <sup>4</sup> reliquasque civitates sollicitant, ut in ea libertate quam a majoribus acceperant permanere, 20 quam Romanorum servitutem perferre mallent. <sup>5</sup> Omni ora maritima celeriter ad suam sententiam perducta, communem legationem ad P. Crassum mittunt, si velit suos recipere, obsides sibi remittat.

9. Quibus de rebus Caesar ab Crasso certior factus, 25 quod ipse aberat longius, naves interim longas aedificari in flumine Ligere, quod influit in Oceanum, remiges ex provincia institui, nautas gubernatoresque comparari jubet. His rebus celeriter administratis, ipse, cum primum per anni tempus potuit, ad exerci- 30 tum contendit. <sup>2</sup> Veneti reliquaeque item civitates, cognito Caesaris adventu [certiores facti], simul quod quantum in se facinus admisisissent intellegebant, legatos — quod nomen ad omnes nationes sanctum inviolatumque semper fuisset — retentos ab se et in vincla conjec- 35 tos, pro magnitudine periculi bellum parare, et maxime

ea quae ad usum navium pertinent providere instituunt, hoc majore spe, quod multum natura loci confidebant. <sup>3</sup> Pedestria esse itinera concisa aestuariis, navigationem impeditam propter inscientiam locorum paucitatemque portuum sciebant, neque nostros exercitus propter frumenti inopiam diutius apud se morari posse confidebant: <sup>4</sup> ac jam ut omnia contra opinionem acciderent, tamen se plurimum navibus posse, Romanos neque ullam facultatem habere navium, neque eorum <sup>10</sup> locorum ubi bellum gesturi essent vada, portus, insulas novisse; ac longe aliam esse navigationem in concluso mari atque in vastissimo atque apertissimo Oceano perspiciebant. <sup>5</sup> His initis consiliis, oppida muniunt, frumenta ex agris in oppida comportant, naves in <sup>15</sup> Venetiam, ubi Caesarem primum esse bellum gesturum constabat, quam plurimas possunt, cogunt. Socios sibi ad id bellum Osismos, Lexovios, Namnetes, Ambiliatos, Morinos, Diablintres, Menapios adsciscunt; auxilia ex Britannia, quae contra eas regiones <sup>20</sup> posita est, arcessunt.

10. Erant hae difficultates belli gerendi, quas supra ostendimus, sed multa Caesarem tamen ad id bellum incitabant: injuriae retentorum equitum Romanorum, rebellio facta post deditionem, defectio datis obsidibus, <sup>25</sup> tot civitatum conjuratio; imprimis ne, hac parte neglecta, reliquae nationes sibi idem licere arbitrarentur. <sup>2</sup> Itaque cum intellegeret omnes fere Gallos novis rebus studere, et ad bellum mobiliter celeriterque excitari, omnes autem homines natura libertati studere et conditionem servitutis odisse, priusquam plures civitates <sup>30</sup> conspirarent, partiendum sibi ac latius distribuendum exercitum putavit.

11. Itaque T. Labienum legatum in Treveros, qui proximi flumini Rheno sunt, cum equitatu mittit. <sup>35</sup> Huic mandat Remos reliquosque Belgas adeat, atque in officio contineat; Germanosque, qui auxilio a Belgis



arcessiti dicebantur, si per vim navibus flumen transire conentur, prohibeat. <sup>2</sup>P. Crassum, cum cohortibus legionariis duodecim et magno numero equitatus, in Aquitaniam proficisci jubet, ne ex his nationibus auxilia in Galliam mittantur, ac tantae nationes con- 5 jungantur. <sup>3</sup>Q. Titurium Sabinum legatum cum legionibus tribus in Unellos, Curiosolites Lexoviosque mittit, qui eam manum distinendam curet. <sup>4</sup>Decimum Brutum adolescentem classi Gallicisque navibus, quas ex Pictonibus et Santonis reliquisque pacatis regionibus 10 convenire jusserat, praeficit, et, cum primum posset, in Venetos proficisci jubet. Ipse eo pedestribus copiis contendit.

12. Erant ejusmodi fere situs oppidorum, ut, posita in extremis lingulis promunturiisque, neque pedibus 15 aditum haberent, cum ex alto se aestus incitavisset (quod [bis] accidit semper horarum XII spatio), neque navibus, quod rursus minuente aestu naves in vadis adfluctarentur. <sup>2</sup>Ita utraque re oppidorum oppugnatio impediabatur; ac si quando — magnitudine operis forte 20 superati, extruso mari aggere ac molibus, atque his oppidi moenibus adaequatis — suis fortunis desperare coeperant, magno numero navium adpulso, cujus rei summam facultatem habebant, sua deportabant omnia, seque in proxima oppida recipiebant: ibi se rursus 25 isdem opportunitatibus loci defendebant. <sup>3</sup>Hæc eo facilius magnam partem aestatis faciebant, quod nostrae naves tempestatibus detinebantur, summaque erat — vasto atque aperto mari, magnis aestibus, raris ac prope nullis portibus — difficultas navigandi. 30

13. Namque ipsorum naves ad hunc modum factae armataeque erant: carinae aliquanto planiores quam nostrarum navium, quo facilius vada ac decessum aestus excipere possent; <sup>2</sup>prorae admodum erectae, atque item puppes ad magnitudinem fluctuum tempestatumque adcommodatae; naves totae factae ex robore 35

ad quamvis vim et contumeliam perferendam; transtra  
 pedalibus in altitudinem trabibus confixa clavis ferreis  
 digiti pollicis crassitudine; <sup>3</sup>ancorae pro funibus fer-  
 reis catenis revinctae; pelles pro velis alutaeque tenui-  
 5 ter confectae, hae sive propter lini inopiam atque ejus  
 usus inscientiam, sive eo (quod est magis verisimile)  
 quod tantas tempestates Oceani tantosque impetus  
 ventorum sustineri ac tanta onera navium regi velis  
 non satis commode posse arbitrabantur. <sup>4</sup>Cum his  
 10 navibus nostrae classi ejusmodi congressus erat, ut  
 una celeritate et pulsu remorum praestaret; reliqua  
 pro loci natura, pro vi tempestatum, illis essent aptiora  
 et accommodatiora. <sup>5</sup>Neque enim his nostrae rostro  
 nocere poterant — tanta in iis erat firmitudo — neque  
 15 propter altitudinem facile telum adiciebatur, et eadem  
 de causa minus commode copulis continebantur. <sup>6</sup>Ac-  
 cedebat ut, cum saevire ventus coepisset et se vento  
 dedissent, et tempestatem ferrent facilius, et in vadis  
 consisterent tutius, et ab aestu relictæ nihil saxa et  
 20 cautes timerent; quarum rerum omnium nostris navi-  
 bus casus erat extimescendus.

14. Compluribus expugnatis oppidis, Caesar, ubi  
 intellexit frustra tantum laborem sumi, neque hostium  
 fugam captis oppidis reprimi neque iis noceri posse,  
 25 statuit exspectandam classem. <sup>2</sup>Quae ubi convenit  
 ac primum ab hostibus visa est, circiter ccxx naves  
 eorum, paratissimae atque omni genere armorum  
 ornatissimae, profectae ex portu, nostris adversae con-  
 stiterunt; neque satis Bruto, qui classi praerat, vel  
 30 tribunis militum centurionibusque, quibus singulae  
 naves erant adtributae, constabat quid agerent, aut  
 quam rationem pugnae insisterent. <sup>3</sup>Rostro enim  
 noceri non posse cognoverant; turribus autem excita-  
 tis, tamen has altitudo puppium ex barbaris navibus  
 35 superabat; ut neque ex inferiore loco satis commode  
 tela adici possent, et missa ab Gallis gravius accide-

rent. <sup>4</sup>Una erat magno usui res præparata a nostris, —falces præacutæ insertæ adfixæque longuriis, non absimili forma muralium falcium. <sup>5</sup>His cum funes, qui antemnas ad malos destinabant, comprehensi adductique erant, navigio remis incitato præerumpebantur. <sup>6</sup>Quibus abscisis antemnae necessario concidebant; ut, cum omnis Gallicis navibus spes in velis armamentisque consisteret, his ereptis, omnis usus navium uno tempore eriperetur. <sup>7</sup>Reliquum erat certamen positum in virtute, qua nostri milites facile superabant, atque eo magis, quod in conspectu Cæsar's atque omnis exercitus res gerebatur, ut nullum paulo fortius factum latere posset; omnes enim colles ac loca superiora, unde erat propinquus despectus in mare, ab exercitu tenebantur. 15

15. Disjectis (ut diximus) antemnis, cum singulas binæ ac ternæ naves circumsteterant, milites summa vi transcendere in hostium naves contendebant. <sup>2</sup>Quod postquam barbari fieri animadverterunt, expugnatis compluribus navibus, cum ei rei nullum reperiretur auxilium, fuga salutem petere contenderunt. <sup>3</sup>Ac jam, conversis in eam partem navibus quo ventus ferebat, tanta subito malacia ac tranquillitas exstitit, ut se ex loco commovere non possent. <sup>4</sup>Quæ quidem res ad negotium conficiendum maxime fuit opportuna: <sup>25</sup>nam singulas nostri consectati expugnaverunt, ut per paucae ex omni numero noctis interventu ad terram pervenerint, cum ab hora fere quarta usque ad solis occasum pugnaretur.

16. Quo proelio bellum Venetorum totiusque orae <sup>30</sup>maritimæ confectum est. Nam cum omnis juvenus, omnes etiam gravioris ætatis, in quibus aliquid consilii aut dignitatis fuit, eo convenerant, tum navium quod ubique fuerat unum in locum coëgerant; <sup>2</sup>quibus amissis, reliqui neque quo se reciperent, neque quem <sup>35</sup>ad modum oppida defenderent habebant. Itaque se

suaque omnia Caesari dediderunt. <sup>3</sup>In quos eo gravius Caesar vindicandum statuit, quo diligentius in reliquum tempus a barbaris jus legatorum conservaretur. Itaque, omni senatu necato, reliquos sub corona vendidit.

17. Dum haec in Venetis geruntur, Q. Titurius Sabinus, cum iis copiis quas a Caesare acceperat, in fines Unellorum pervenit. His praeerat Viridovix, ac summam imperii tenebat earum omnium civitatum quae defecerant, ex quibus exercitum magnasque copias coëgerat; <sup>2</sup>atque his paucis diebus Aulerci, Eburovices, Lexoviique, senatu suo interfecto, quod auctores belli esse nolebant, portas clauserunt, seque cum Viridovice conjunxerunt; magnaue praeterea multitudo undique ex Gallia perditorum hominum latronumque convenerat, quos spes praedandi studiumque bellandi ab agricultura et cotidiano labore revocabat. <sup>3</sup>Sabinus idoneo omnibus rebus loco castris sese tenebat, cum Viridovix contra eum duum milium spatio consedisset, cotidieque productis copiis pugnandi potestatem faceret; ut jam non solum hostibus in contemptionem Sabinus veniret, sed etiam nostrorum militum vocibus nonnihil carperetur; tantamque opinionem timoris praebuit, ut jam ad vallum castrorum hostes accedere auderent. <sup>4</sup>Id ea de causa faciebat, quod cum tanta multitudine hostium, praesertim eo absente qui summam imperii teneret, nisi aequo loco aut opportunitate aliqua data, legato dimicandum non existimabat.

18. Hac confirmata opinione timoris, idoneum quendam hominem et callidum delegit, Gallum, ex iis quos auxilii causa secum habebat. Huic magnis praemiis pollicitationibusque persuadet, uti ad hostes transeat, et quid fieri velit edocet. <sup>2</sup>Qui ubi pro perfuga ad eos venit, timorem Romanorum proponit; quibus angustiis ipse Caesar a Venetis prematur docet; neque longius

abesse quin proxima nocte Sabinus clam ex castris exercitum educat, et ad Caesarem auxilii ferendi causa proficiscatur. <sup>3</sup> Quod ubi auditum est, conclamant omnes occasionem negotii bene gerendi amittendam non esse, ad castra iri oportere. <sup>4</sup> Multae res ad hoc 5 consilium Gallos hortabantur: superiorum dierum Sabini cunctatio, perfugae confirmatio, inopia cibariorum, cui rei parum diligenter ab iis erat provisum, spes Venetici belli, et quod fere libenter homines id quod 10 volunt credunt. <sup>5</sup> His rebus adducti, non prius Viridovicem reliquosque duces ex concilio dimittunt, quam ab his sit concessum, arma uti capiant et ad castra contendant. <sup>6</sup> Qua re concessa, laeti ut explorata victoria, sarmentis virgultisque collectis, quibus fossas Romanorum compleant, ad castra pergunt. 15

19. Locus erat castrorum editus, et paulatim ab imo adclivis circiter passus mille. Huc magno cursu contenderunt, ut quam minimum spatii ad se colligendos armandosque Romanis daretur, exanimatique pervererunt. <sup>2</sup> Sabinus, suos hortatus, cupientibus signum 20 dat. Impeditis hostibus propter ea quae ferebant onera, subito duabus portis eruptionem fieri jubet. <sup>3</sup> Factum est opportunitate loci, hostium inscientia ac defetigatione, virtute militum et superiorum pugnarum exercitatione, ut ne unum quidem nostrorum impetum 25 ferrent, ac statim terga verterent. <sup>4</sup> Quos impeditos integris viribus milites nostri consecuti, magnum numerum eorum occiderunt; reliquos equites consecrati paucos, qui ex fuga evaserant, reliquerunt. <sup>5</sup> Sic uno tempore et de navali pugna Sabinus et de Sabini victoria Caesar certior factus *est*; civitatesque omnes 30 se statim Titurio dederunt. <sup>6</sup> Nam ut ad bella suscipienda Gallorum alacer ac promptus est animus, sic mollis ac minime resistens ad calamitates perferendas mens eorum est. 35

20. Eodem fere tempore P. Crassus cum in Aquita-

niam pervenisset, — quae pars, ut ante dictum est, et regionum latitudine et multitudine hominum ex tertia parte Galliae est aestimanda, — cum intellegeret in iis locis sibi bellum gerendum, ubi paucis ante annis L. Valerius Praeconinus legatus exercitu pulso interfectus esset, atque unde L. Mallius proconsul impedimentis amissis profugisset, non mediocrem sibi diligentiam adhibendam intellegebat. <sup>2</sup> Itaque re frumentaria provisā, auxiliis equitatuque comparato, multis praeterea viris fortibus Tolosa et Narbone (quae sunt civitates Galliae provinciae finitimae his regionibus) nominatim evocatis, in Sontiatum fines exercitum introduxit. <sup>3</sup> Cujus adventu cognito, Sontiates magnis copiis coactis equitatuque, quo plurimum valebant, in itinere agmen nostrum adorti, primum equestre proelium commiserunt; deinde equitatu suo pulso, atque insequentibus nostris, subito pedestres copias, quas in convalle in insidiis conlocaverant, ostenderunt. Hi nostros disjectos adorti, proelium renovarunt.

21. Pugnatum est diu atque acriter, cum Sontiates, superioribus victoriis freti, in sua virtute totius Aquitaniae salutem positam putarent; nostri autem quid sine imperatore et sine reliquis legionibus adulescentulo duce efficere possent, perspici cuperent: tandem confecti vulneribus hostes terga vertere. <sup>2</sup> Quorum magno numero interfecto, Crassus ex itinere oppidum Sontiatum oppugnare coepit. Quibus fortiter resistentibus, vineas turresque egit. <sup>3</sup> Illi, alias eruptione temptata, alias cuniculis ad aggerem vineasque actis (cujus rei sunt longe peritissimi Aquitani, propterea quod multis locis apud eos aerariae † secturaeque sunt), ubi diligentia nostrorum nihil his rebus profici posse intellexerunt, legatos ad Crassum mittunt, seque in deditionem ut recipiat petunt. Qua re impetrata, arma tradere jussi, faciunt.

22. Atque in ea re omnium nostrorum intentis ani-

mis, alia ex parte oppidi Adiatunnus, qui summam imperii tenebat, cum sexcentis devotis, quos illi *soldu-rios* appellant, —<sup>2</sup>quorum haec est condicio, uti omnibus in vita commodis una cum iis fruantur quorum se amicitiae dederint; si quid his per vim accidat, aut eundem casum una ferant, aut sibi mortem consciscant; neque adhuc hominum memoria repertus est quisquam, qui eo interfecto, cujus se amicitiae devovisset, mori recusaret, —<sup>3</sup>cum his Adiatunnus, eruptionem facere conatus, clamore ab ea parte munitio-  
10 sublato, cum ad arma milites concurrissent vehementerque ibi pugnatum esset, repulsus in oppidum, tamen uti eadem deditio-  
5 nis condicione uteretur ab Crasso impetravit.

23. Armis obsidibusque acceptis, Crassus in fines  
15 Vocatium et Tarusatium profectus est. Tum vero barbari commoti, quod oppidum et natura loci et manu munitum paucis diebus, quibus eo ventum erat, expugnatum cognoverant, legatos quoqueversum dimittere, conjurare, obsides inter se dare, copias parare coepe-  
20 runt. <sup>2</sup>Mittuntur etiam ad eas civitates legati, quae sunt citerioris Hispaniae finitimae Aquitaniae: inde auxilia ducesque arcessuntur; quorum adventu, magna cum auctoritate et magna cum hominum multitudine bellum gerere conantur. <sup>3</sup>Duces vero ii deligun-  
25 tur, qui una cum Q. Sertorio omnes annos fuerant, summamque scientiam rei militaris habere existimabantur. Hi consuetudine populi Romani loca capere, castra munire, com meatibus nostros intercludere instituunt. <sup>4</sup>Quod ubi Crassus animadvertit, — suas  
30 copias propter exiguitatem non facile diduci, hostem et vagari et vias obsidere et castris satis praesidii relinquere, ob eam causam minus commode frumentum com meatumque sibi supportari, in dies hostium numerum augeri, — non cunctandum existimavit quin  
35 pugna decertaret. <sup>5</sup>Hac re ad consilium delata, ubi

omnes idem sentire intellexit, posterum diem pugnae constituit.

24. Prima luce, productis omnibus copiis, duplici acie instituta, auxiliis in mediam aciem coniectis, quid  
5 hostes consilii caperent exspectabat. <sup>2</sup>Illi, etsi propter multitudinem et veterem belli gloriam paucitatemque nostrorum se tuto dimicaturos existimabant, tamen tutius esse arbitrabantur, obsessis viis, commeatu intercluso, sine ullo vulnere victoria potiri; et, si propter  
10 inopiam rei frumentariae Romani sese recipere coepissent, impeditos in agmine et sub sarcinis infirmiore animo adoriri cogitabant. Hoc consilio probato, ab ducibus productis Romanorum copiis, sese castris tenebant. <sup>3</sup>Hac re perspecta, Crassus, cum sua cunctatione atque opinione timoris hostes nostros milites  
15 alacriores ad pugnandum effecissent, atque omnium voces audirentur, exspectari diutius non oportere quin ad castra iretur, cohortatus suos, omnibus cupientibus, ad hostium castra contendit.

20 25. Ibi cum alii fossas complerent, alii multis telis coniectis defensores vallo munitionibusque depellerent, auxiliaresque (quibus ad pugnam non multum Crassus confidebat) lapidibus telisque subministrandis et ad aggerem cespitibus comportandis speciem atque opini-  
25 onem pugnantium praeberent; <sup>2</sup>cum item ab hostibus constanter ac non timide pugnaretur, telaque ex loco superiore missa non frustra acciderent, equites circum-  
itis hostium castris Crasso renuntiaverunt, non eadem esse diligentia ab decumana porta castra munita,  
30 facilemque aditum habere.

26. Crassus, equitum praefectos cohortatus ut magnis praemiis pollicitationibusque suos excitarent, quid fieri velit ostendit. <sup>2</sup>Illi, ut erat imperatum, eductis iis cohortibus quae praesidio castris relictæ intritæ ab  
35 labore erant, et longiore itinere circumductis, ne ex hostium castris conspici possent, omnium oculis menti-



busque ad pugnam intentis, celeriter ad eas quas diximus munitiones pervenerunt, atque his prorotis, prius in hostium castris constiterunt quam plane ab his videri, aut quid rei gereretur cognosci posset.

<sup>3</sup> Tum vero, clamore ab ea parte audito, nostri redintegratis viribus, quod plerumque in spe victoriae accidere consuevit, acrius impugnare coeperunt. <sup>4</sup> Hostes undique circumventi, desperatis omnibus rebus, se per munitiones deicere et fuga salutem petere intenderunt.

<sup>5</sup> Quos equitatus apertissimis campis consecutus, ex milium quinquaginta numero, quae ex Aquitania Cantabrisque convenisse constabat, vix quarta parte relicta, multa nocte se in castra recipit.

27. Hac audita pugna, maxima pars Aquitaniae sese Crasso dedit, obsidesque ultro misit; quo in numero fuerunt Tarbelli, Bigerriones, Ptianii, Vocates, Tarusates, Elusates, Gates, Ausci, Garumni, Sibuzates, Cocosates: paucae ultimae nationes, anni tempore confisae, quod hiems suberat, hoc facere neglexerunt.

28. Eodem fere tempore Caesar, etsi prope exacta jam aestas erat, tamen quod, omni Gallia pacata, Morini Menapiique supererant qui in armis essent, neque ad eum unquam legatos de pace misissent, arbitratus id bellum celeriter confici posse, eo exercitum adduxit; qui longe alia ratione ac reliqui Galli bellum gerere coeperunt. <sup>2</sup> Nam quod intellegebant maximas nationes, quae proelio contendissent, pulsas superatasque esse, continentesque silvas ac paludes habebant, eo se suaeque omnia contulerunt. <sup>3</sup> Ad quarum initium silvarum cum Caesar pervenisset, castraque munire instituisset, neque hostis interim visus esset, dispersis in opere nostris, subito ex omnibus partibus silvae evolverunt, et in nostros impetum fecerunt. <sup>4</sup> Nostri celeriter arma ceperunt, eosque in silvas repulerunt, et compluribus interfectis, longius impeditioribus locis secuti, paucos ex suis deperdiderunt.

29. Reliquis deinceps diebus Caesar silvas caedere instituit, et ne quis inermibus imprudentibusque militibus ab latere impetus fieri posset, omnem eam materiam, quae erat caesa, conversam ad hostem con-  
5 locabat, et pro vallo ad utrumque latus exstruebat. <sup>2</sup>Incredibili celeritate magno spatio paucis diebus confecto, cum jam pecus atque extrema impedimenta ab nostris tenerentur, ipsi densiores silvas peterent, ejus-  
10 modi sunt tempestates consecutae, uti opus necessario intermitteretur, et continuatione imbrium diutius sub  
pellibus milites contineri non possent. <sup>3</sup>Itaque vastatis omnibus eorum agris, vicis aedificiisque incensis, Caesar exercitum reduxit, et in Aulercis Lexoviisque,  
15 in hibernis conlocavit.



Map No. 4.  
**CAMPAIGNS OF**  
**B.C. 55 and 54.**

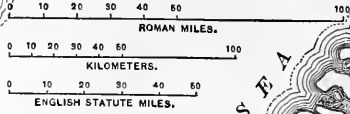

Latin Names are in Roman Type  
 Modern Names are in *Italic Type*

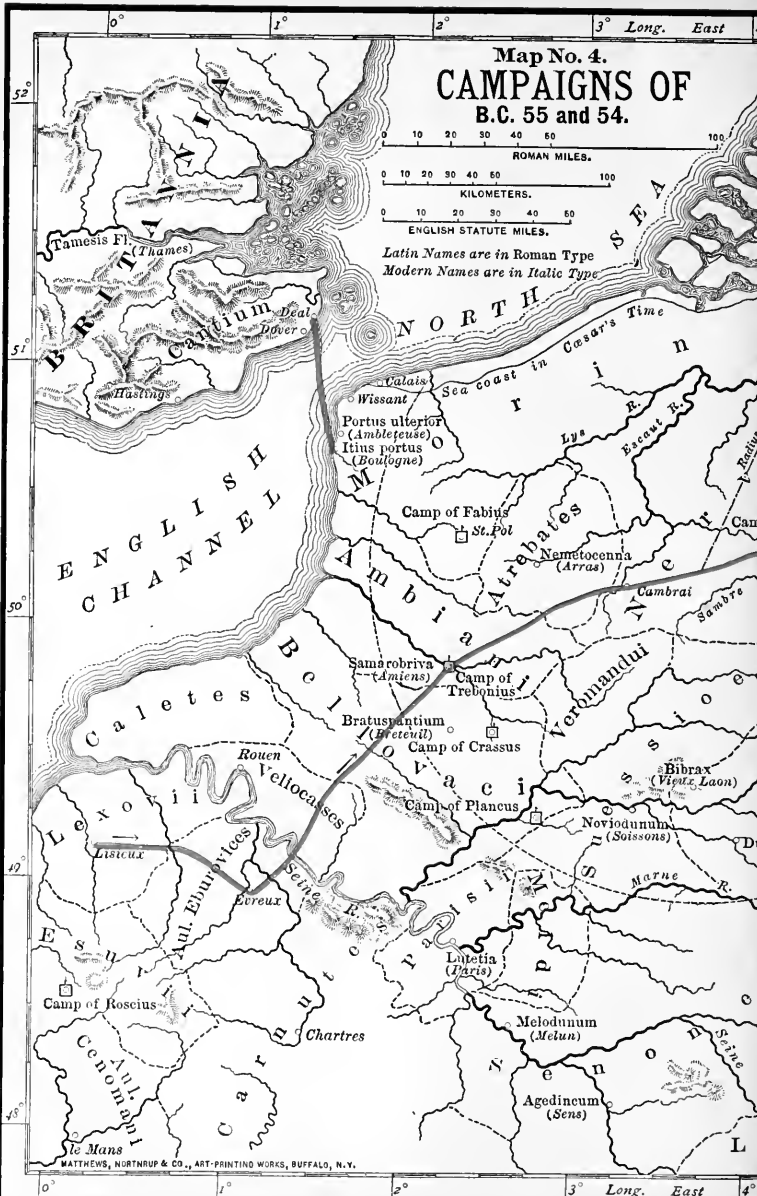

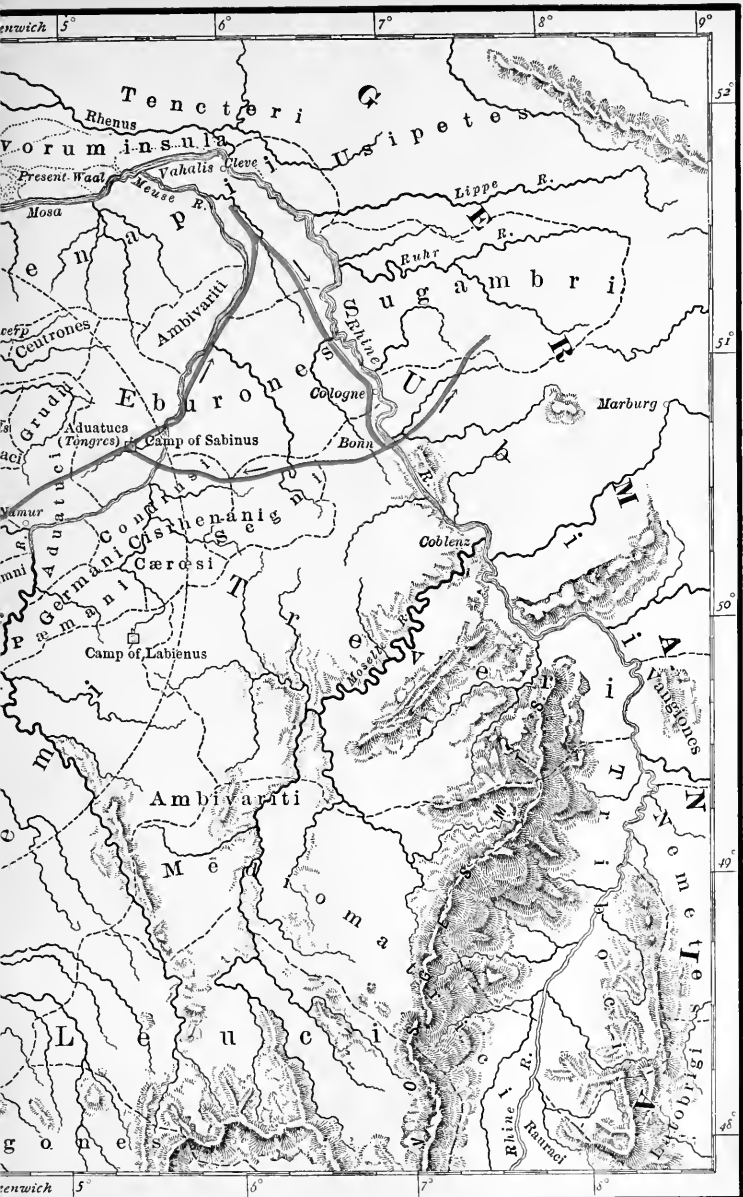

5° 6° 7° 8° 9°

53°

51°

50°

49°

46°

5° 6° 7° 8° 9°



## BOOK IV.

CAMPAIGN AGAINST THE GERMANS. — The Suevi (*Swabians*), the most powerful tribe of Germans: their customs and warlike habit. They expel the Usipetes and Tencteri, who in their turn invade Northern Gaul (1-4). Advancing to strengthen the Gauls, who are about to yield, Cæsar demands that the Germans withdraw: after some parley, they furiously attack the Roman cavalry (5-12). Detaining their envoys, Cæsar attacks their camp, defeats and drives them to the Rhine (13-15). He then resolves to cross the Rhine: description of the Bridge (16, 17). After a short campaign in Germany, he returns to Gaul (18, 19).

FIRST INVASION OF BRITAIN. — Motives for the expedition: the reconnoissance and preparations (20-22). Arrival in Britain: resistance of the Britons; valor of a Roman centurion. Cæsar lands, and after a sharp battle drives back the natives, who sue for peace (23-27). Meanwhile the Roman cavalry are forced back by a storm, and the fleet is seriously injured; on which the Britons renew hostilities (28-32). They attack a foraging party: their mode of fighting from war-chariots. Gathering a large force, they attack the Roman camp: defeating them, Cæsar makes peace and returns to Gaul to avoid the stormy season (33-36). Suppressing some disturbances, he quarters his forces among the Belgians for the winter (37, 38).

EA quae secuta est hieme, qui fuit annus Gnaeo Pompeio, Marco Crasso consulibus, Usipetes Germani et item Tencteri magna cum multitudine hominum flumen Rhenum transierunt, non longe a mari quo Rhenus influit. <sup>2</sup>Causa transeundi fuit quod, <sup>5</sup> ab Suevis complures annos exagitati, bello premebantur et agricultura prohibebantur. Suevorum gens est longe maxima et bellicosissima Germanorum omnium. <sup>3</sup>Hi centum pagos habere dicuntur, ex quibus quotannis singula milia armatorum bellandi causa ex <sup>10</sup> finibus educunt. Reliqui, qui domi manserunt, se atque illos alunt. <sup>4</sup>Hi rursus in vicem anno post in

armis sunt, illi domi remanent. Sic neque agricultura nec ratio atque usus belli intermittitur. <sup>5</sup> Sed privati ac separati agri apud eos nihil est, neque longius anno remanere uno in loco incolendi causa licet. <sup>6</sup> Neque multum frumento, sed maximam partem lacte atque pecore vivunt, multumque sunt in venationibus; quae res et cibi genere et cotidiana exercitatione et libertate vitae, quom a pueris nullo officio aut disciplina adsuefacti nihil omnino contra voluntatem <sup>10</sup> faciant, et vires alit, et immani corporum magnitudine homines efficit. <sup>7</sup> Atque in eam se consuetudinem adduxerunt, ut locis frigidissimis neque vestitus praeter pellis haberent quicquam, quarum propter exiguitatem magna est corporis pars aperta, et lavarentur in flumibus. <sup>15</sup>

2. Mercatoribus est aditus magis eo, ut quae bello ceperint quibus vendant habeant, quam quo ullam rem ad se importari desiderent. <sup>2</sup> Quin etiam jumentis, quibus maxime Galli delectantur, quaeque impenso <sup>20</sup> parant pretio, Germani importatis non utuntur; sed quae sunt apud eos nata, parva atque deformia, haec cotidiana exercitatione summi ut sint laboris efficiunt. <sup>3</sup> Equestribus proeliis saepe ex equis desiliunt ac pedibus proeliantur, equosque eodem remanere vestigio <sup>25</sup> adsuefecerunt, ad quos se celeriter, cum usus est, recipiunt; neque eorum moribus turpius quicquam aut inertius habetur quam ephippiis uti. <sup>4</sup> Itaque ad quemvis numerum ephippiatorum equitum quamvis pauci adire audent. Vinum ad se omnino importari <sup>30</sup> non sinunt, quod ea re ad laborem ferendum remollescere homines atque effeminari arbitrantur.

3. Publice maximam putant esse laudem quam latissime a suis finibus vacare agros: hac re significari magnum numerum civitatum suam vim sustinere non <sup>35</sup> posse. Itaque una ex parte a Suevis circiter milia passuum sexcenta agri vacare dicuntur. <sup>2</sup> Ad alteram



partem succedunt Ubii, quorum fuit civitas ampla atque florens, ut est captus Germanorum, et paulo [quam] sunt ejusdem generis [et] ceteris humaniores, propterea quod Rhenum attingunt, multumque ad eos mercatores ventitant, et ipsi propter propinquitatem 5 [quod] Gallicis sunt moribus adsuefacti. <sup>3</sup> Hos cum Suevi, multis saepe bellis experti, propter amplitudinem gravitatemque civitatis finibus expellere non potuissent, tamen vectigales sibi fecerunt, ac multo humiliores infirmioresque redegerunt. 10

4. In eadem causa fuerunt Usipetes et Tencteri, quos supra diximus, qui complures annos Suevorum vim sustinuerunt; ad extremum tamen, agris expulsi et multis locis Germaniae triennium vagati, ad Rhenum pervenerunt: <sup>2</sup> quas regiones Menapii incolebant, 15 et ad utramque ripam fluminis agros aedificia vicosque habebant; sed tantae multitudinis aditu perterriti, ex iis aedificiis quae trans flumen habuerant demigraverunt, et cis Rhenum dispositis praesidiis Germanos transire prohibebant. <sup>3</sup> Illi omnia experti, cum neque 20 vi contendere propter inopiam navium neque clam transire propter custodias Menapiorum possent, reverti se in suas sedes regionesque simulaverunt, et tridui viam progressi rursus reverterunt, atque omni hoc itinere una nocte equitatu confecto, inscios inopinantesque Menapios oppresserunt; qui de Germanorum discessu per exploratores certiores facti, sine metu trans Rhenum in suos vicos remigraverant. <sup>4</sup> His interfectis navibusque eorum occupatis, priusquam ea pars Menapiorum, quae citra Rhenum erat, certior 30 fieret, flumen transierunt; atque omnibus eorum aedificiis occupatis, reliquam partem hiemis se eorum copiis aluerunt.

5. His de rebus Caesar certior factus, et infirmitatem Gallorum veritus, quod sunt in consiliis capiendis 35 mobiles et novis plerumque rebus student, nihil his

committendum existimavit. <sup>2</sup> Est enim hoc Gallicae consuetudinis, uti et viatores etiam invitos consistere cogant, et quid quisque eorum de quaque re audierit aut cognoverit quaerant; et mercatores in oppidis  
 5 vulgus circumstet, quibusque ex regionibus veniant quasque ibi res cognoverint pronuntiare cogant. <sup>3</sup> His rebus atque auditionibus permoti de summis saepe rebus consilia ineunt, quorum eos in vestigio paenitere necesse est, cum incertis rumoribus serviant, et plerique  
 10 ad voluntatem eorum ficta respondeant.

6. Qua consuetudine cognita, Caesar, ne graviori bello occurreret, maturius quam consuerat ad exercitum proficiscitur. <sup>2</sup> Eo cum venisset, ea quae fore suspicatus erat, facta cognovit: missas legationes ab  
 15 nonnullis civitatibus ad Germanos, invitatosque eos uti ab Rheno discederent, omniaque quae postulassent ab se fore parata. <sup>3</sup> Qua spe adducti, Germani latius vagabantur, et in fines Eburonum et Condrusorum, qui sunt Treverorum clientes, pervenerant. <sup>4</sup> Prin-  
 20 cipibus Galliae evocatis, Caesar ea quae cognoverat dissimulanda sibi existimavit, eorumque animis permulsis et confirmatis, equitatuque imperato, bellum cum Germanis gerere constituit.

7. Re frumentaria comparata equitibusque delectis,  
 25 iter in ea loca facere coepit, quibus in locis esse Germanos audiebat. <sup>2</sup> A quibus cum paucorum dierum iter abesset, legati ab iis venerunt, quorum haec fuit oratio: 'Germanos neque priores populo Romano bellum inferre, neque tamen recusare, si lacesantur, quin  
 30 armis contendant, quod Germanorum consuetudo haec sit a majoribus tradita, quicumque bellum inferant, resistere neque deprecari. <sup>3</sup> Haec tamen dicere, venisse invitos, ejectos domo; si suam gratiam Romani velint, posse iis utiles esse amicos; vel sibi agros  
 35 adtribuant, vel patiantur eos tenere quos armis possederint: sese unis Suevis concedere, quibus ne dii

quidem immortales pares esse possint ; reliquum quidem in terris esse neminem, quem non superare possint.'

8. Ad haec quae visum est Caesar respondit ; sed exitus fuit orationis : 'Sibi nullam cum his amicitiam 4 esse posse, si in Gallia remanerent ; neque verum esse, qui suos fines tueri non potuerint, alienos occupare ; <sup>2</sup>neque ullos in Gallia vacare agros, qui dari tantae praesertim multitudini sine injuria possint ; sed licere, si velint, in Ubiorum finibus considerare, quorum 10 sint legati apud se et de Suevorum injuriis querantur et a se auxilium petant : hoc se Ubiis imperaturum.'

9. Legati haec se ad suos relatores dixerunt, et re deliberata post diem tertium ad Caesarem reversuros : interea ne propius se castra moveret petierunt. Ne id 15 quidem Caesar ab se impetrari posse dixit. <sup>2</sup>Cognoverat enim magnam partem equitatus ab iis aliquot diebus ante praedandi frumentandique causa ad Ambivaritos trans Mosam missam : hos exspectari equites, atque ejus rei causa moram interponi arbitrabatur. 20

10. Mosa profluit ex monte Vosego, qui est in finibus Lingonum, et parte quadam ex Rheno recepta, quae appellatur Vacalus † insulamque efficit Batavorum, in Oceanum influit, neque longius ab Oceano milibus passuum LXXX in Rhenum influit. <sup>2</sup>Rhenus autem 25 oritur ex Lepontiis, qui Alpes incolunt, et longo spatio per fines Nantuatum, Helvetiorum, Sequanorum, Mediomatricum, Tribocorum, Treverorum citatus fertur ; et, ubi Oceano adpropinquavit, in plures defluit partes, multis ingentibusque insulis effectis, quarum 30 pars magna a feris barbarisque nationibus incolitur, ex quibus sunt qui piscibus atque ovis avium vivere existimantur, multisque capitibus in Oceanum influit.

11. Caesar cum ab hoste non amplius passum XII milibus abesset, ut erat constitutum, ad eum legati 35 revertuntur ; qui in itinere congressi magnopere ne

longius progrediretur orabant. <sup>2</sup>Cum id non impe-  
trassent, petebant uti ad eos equites qui agmen ante-  
cessissent praemitteret, eosque pugna prohiberet,  
sibi que ut potestatem faceret in Ubios legatos mit-  
5 tendi; quorum si principes ac senatus sibi jurejurando  
fidem fecisset, ea condicione quae a Caesare ferretur  
se usuros ostendebant: ad has res conficiendas sibi  
tridui spatium daret. <sup>3</sup>Haec omnia Caesar eodem  
illo pertinere arbitrabatur, ut tridui mora interposita  
10 equites eorum, qui abessent, reverterentur: tamen  
sese non longius milibus passuum quattuor aquationis  
causa processurum eo die dixit; huc postero die quam  
frequentissimi convenirent, ut de eorum postulatis  
cognosceret. <sup>4</sup>Interim ad praefectos, qui cum omni  
15 equitatu antecesserant, mittit qui nuntiarent ne hostes  
proelio lacerent; et, si ipsi lacerentur, sustine-  
rent, quoad ipse cum exercitu propius accessisset.

12. At hostes, ubi primum nostros equites conspexe-  
runt, quorum erat quinque milium numerus, cum ipsi  
20 non amplius octingentos equites haberent, quod ii qui  
frumentandi causa ierant trans Mosam nondum redie-  
rant, nihil timentibus nostris, quod legati eorum paulo  
ante a Caesare discesserant atque is dies indutiis erat  
ab his petitus, impetu facto celeriter nostros pertur-  
25 baverunt; <sup>2</sup>rursus resistentibus, consuetudine sua ad  
pedes desiluerunt, subfossis equis compluribusque nos-  
tris dejectis, reliquos in fugam conjecerunt, atque ita  
perterritos egerunt, ut non prius fuga desisterent quam  
in conspectum agminis nostri venissent. <sup>3</sup>In eo proe-  
30 lio ex equitibus nostris interficiuntur quattuor et  
septuaginta; in his vir fortissimus, Piso Aquitanus,  
amplissimo genere natus, cujus avus in civitate sua  
regnum obtinuerat, amicus ab senatu nostro appel-  
latus. <sup>4</sup>Hic cum fratri incluso ab hostibus auxilium  
35 ferret, illum ex periculo eripuit, ipse equo vulnerato  
dejectus, quoad potuit, fortissime restitit: cum circum-

ventus, multis vulneribus acceptis, cecidisset, atque id frater, qui jam proelio excesserat, procul animadvertisset, incitato equo se hostibus obtulit atque interfectus est.

13. Hoc facto proelio, Caesar neque jam sibi legatos 5 audiendos neque condiciones accipiendas arbitratur ab iis, qui per dolum atque insidias, petita pace, ultro bellum intulissent: <sup>2</sup>expectare vero, dum hostium copiae auferentur equitatusque reverteretur, summae dementiae esse judicabat; et cognita Gallorum infirmitate, quantum jam apud eos hostes uno proelio auctoritatis essent consecuti sentiebat; quibus ad consilia capienda nihil spatii dandum existimabat. <sup>3</sup>His constitutis rebus et consilio cum legatis et quaestore communicato, ne quem diem pugnae praetermitteret, 15 opportunissima res accidit, quod postridie ejus diei mane, eadem et perfidia et simulatione usi Germani frequentes, omnibus principibus majoribusque natu adhibitis, ad eum in castra venerunt: <sup>4</sup>simul, ut dicebatur, sui purgandi causa, quod (contra atque esset <sup>20</sup>dictum, et ipsi petissent) proelium pridie commisissent; simul ut, si quid possent, de indutiis fallendo impetrarent. <sup>5</sup>Quos sibi Caesar oblatos gavisus, illos retineri jussit; ipse omnes copias castris eduxit, equitatumque, quod recenti proelio perterritum esse existimabat, 25 agmen subsequi jussit.

14. Acie triplici instituta, et celeriter VIII milium itinere confecto, prius ad hostium castra pervenit quam quid ageretur Germani sentire possent. <sup>2</sup>Qui omnibus rebus subito perterriti, et celeritate adventus nostri <sup>30</sup>et discessu suorum, neque consilii habendi neque arma capiendi spatio dato, perturbantur; copiasne adversus hostem ducere, an castra defendere, an fuga salutem petere praestaret. <sup>3</sup>Quorum timor cum fremitu et concursu significaretur, milites nostri, pristini diei <sup>35</sup>perfidia incitati, in castra inruperunt. <sup>4</sup>Quo loco qui

celeriter arma capere potuerunt, paulisper nostris restiterunt, atque inter carros impedimentaue proelium commiserunt: at reliqua multitudo puerorum mulierumque — nam cum omnibus suis domo excesserant  
 5 Rhenumque transierant — passim fugere coepit; ad quos consectandos Caesar equitatum misit.

15. Germani, post tergum clamore audito, cum suos interfici viderent, armis abjectis signisque militaribus relictis, se ex castris eiecerunt, et cum ad confluentem  
 10 Mosae et Rheni pervenissent, reliqua fuga desperata, magno numero interfecto, reliqui se in flumen praecipitaverunt; atque ibi timore, lassitudine, vi fluminis oppressi perierunt. <sup>2</sup> Nostri ad unum omnes incolumes, perpaucis vulneratis, ex tanti belli timore, cum hostium  
 15 numerus capitum cccxxx milium fuisset, se in castra receperunt. <sup>3</sup> Caesar iis, quos in castris retinuerat, discedendi potestatem fecit. Illi supplicia cruciatuque Gallorum veriti, quorum agros vexaverant, remanere se apud eum velle dixerunt. His Caesar  
 20 libertatem concessit.

16. Germanico bello confecto, multis de causis Caesar statuit sibi Rhenum esse transeundum: quarum illa fuit justissima, quod, cum videret Germanos tam facile impelli ut in Galliam venirent, suis quoque rebus  
 25 eos timere voluit, cum intellegerent et posse et audere populi Romani exercitum Rhenum transire. <sup>2</sup> Accessit etiam, quod illa pars equitatus Usipetum et Tencterorum, quam supra commemoravi praedandi frumentandique causa Mosam transisse, neque proelio  
 30 interfuisse, post fugam suorum se trans Rhenum in fines Sugambrorum receperat, seque cum iis conjunxerat. <sup>3</sup> Ad quos cum Caesar nuntios misisset, qui postularent, eos qui sibi Galliaeque bellum intulissent sibi dederent, responderunt: ‘Populi Romani imperium Rhenum finire: si se invito Germanos in  
 35 Galliam transire non aequum existimaret, cur sui

quicquam esse imperii aut potestatis trans Rhenum postulare?' <sup>4</sup> Ubii autem, qui uni ex Transrhenanis ad Caesarem legatos miserant, amicitiam fecerant, obsides dederant, magnopere orabant ut sibi auxilium ferret, quod graviter ab Suevis premerentur; vel, si id <sup>5</sup> facere occupationibus reipublicae prohiberetur, exercitum modo Rhenum transportaret: id sibi *ad* auxilium spemque reliqui temporis satis futurum. <sup>5</sup> Tantum esse nomen atque opinionem ejus exercitus, Ariovisto pulso et hoc novissimo proelio facto, etiam ad ultimas <sup>10</sup> Germanorum nationes, uti opinione et amicitia populi Romani tuti esse possint. Navium magnam copiam ad transportandum exercitum pollicebantur.

17. Caesar, his de causis quas commemoravi, Rhenum transire decreverat; sed navibus transire neque <sup>15</sup> satis tutum esse arbitrabatur, neque suae neque populi Romani dignitatis esse statuebat. <sup>2</sup> Itaque, etsi summa difficultas faciendi pontis proponebatur propter latitudinem, rapiditatem, altitudinemque fluminis, tamen id sibi contendendum, aut aliter non traducendum exercitum existimabat. <sup>3</sup> Rationem pontis hanc instituit. Tigna bina sesquipedalia, paulum ab imo praeacuta, dimensa ad altitudinem fluminis, intervallo pedum duorum inter se jungebat. <sup>4</sup> Haec cum machinationibus immissa in flumen defixerat, fistucisque adegerat, — <sup>25</sup> non sublicae modo directe ad perpendicularum, sed prone ac fastigate, ut secundum naturam fluminis procumberent, — his item contraria duo ad eundem modum juncta, intervallo pedum quadragenam, ab inferiore parte contra vim atque impetum fluminis conversa <sup>30</sup> statuebat. <sup>5</sup> Haec utraque insuper bipedalibus trabibus immissis, quantum eorum tignorum junctura distabat, binis utrimque fibulis ab extrema parte distinebantur; quibus disclusis, atque in contrariam partem revinctis, tanta erat operis firmitudo atque ea <sup>35</sup> rerum natura, ut, quo major vis aquae se incitavisset,

hoc artius inligata tenerentur. <sup>6</sup> Haec directa materia injecta contexebantur, ac longuriis cratibusque consternebantur; ac nihilo secius sublicae et ad inferiorem partem fluminis oblique agebantur, quae pro ariete  
 5 subjectae et cum omni opere conjunctae vim fluminis exciperent; <sup>7</sup> et aliae item supra pontem mediocri spatio, ut, si arborum trunci sive naves deiciendi operis essent a barbaris missae, his defensoribus earum rerum vis minueretur, neu ponti nocerent.

10 18. Diebus decem, quibus materia coepta erat comportari, omni opere effecto, exercitus traducitur. Caesar, ad utramque partem pontis firmo praesidio relicto, in fines Sugambrorum contendit. <sup>2</sup> Interim a compluribus civitatibus ad eum legati veniunt; quibus  
 15 pacem atque amicitiam petentibus liberaliter respondit, obsidesque ad se adduci jubet. <sup>3</sup> Sugambri, ex eo tempore quo pons institui coeptus est, fuga comparata, hortantibus iis quos ex Tencteris atque Usipetibus apud se habebant, finibus suis excesserant, suaque  
 20 omnia exportaverant, seque in solitudinem ac silvas abdiderant.

19. Caesar, paucos dies in eorum finibus moratus, omnibus vicis aedificiisque incensis, frumentisque succisis, se in fines Ubiorum recipit; atque iis auxilium  
 25 suum pollicitus, si ab Suevis premerentur, haec ab iis cognovit: <sup>2</sup> 'Suevos, posteaquam per exploratores pontem fieri comperissent, more suo concilio habito, nuntios in omnes partes dimisisse, uti de oppidis demigrarent, liberos, uxores, suaque omnia in silvis  
 30 deponerent, atque omnes, qui arma ferre possent, unum in locum convenirent; hunc esse delectum medium fere regionum earum, quas Suevi obtinerent; hic Romanorum adventum expectare, atque ibi decertare constituisse.' <sup>3</sup> Quod ubi Caesar comperit,  
 35 omnibus rebus iis confectis, quarum rerum causa traducere exercitum constituerat, ut Germanis metum



iniceret, ut Sugambros ulcisceretur, ut Ubios obsidione liberaret, diebus omnino decem et octo trans Rhenum consumptis, satis et ad laudem et ad utilitatem profectum arbitratus, se in Galliam recepit, pontemque rescidit.

5

20. Exigua parte aestatis reliqua, Caesar, etsi in his locis (quod omnis Gallia ad septentriones vergit) maturae sunt hiemes, tamen in Britanniam proficisci contendit: <sup>2</sup> quod omnibus fere Gallicis bellis hostibus nostris inde sumministrata auxilia intellegebat; et, si <sup>10</sup> tempus anni ad bellum gerendum deficeret, tamen magno sibi usui fore arbitratur, si modo insulam adisset et genus hominum perspexisset, loca, portus, aditus cognovisset; quae omnia fere Gallis erant incognita. <sup>3</sup> Neque enim temere praeter mercatores illo adit quis- <sup>15</sup> quam, neque iis ipsis quicquam praeter oram maritimam atque eas regiones, quae sunt contra Gallias, notum est. <sup>4</sup> Itaque vocatis ad se undique mercatoribus, neque quanta esset insulae magnitudo, neque quae aut quantae nationes incolerent, neque quem usum belli habe- <sup>20</sup> rent aut quibus institutis uterentur, neque qui essent ad majorum navium multitudinem idonei portus, reperire poterat.

21. Ad haec cognoscenda, priusquam periculum faceret, idoneum esse arbitratus, Gaium Volusenum cum <sup>25</sup> navi longa praemittit. Huic mandat, ut exploratis omnibus rebus ad se quam primum revertatur. <sup>2</sup> Ipse cum omnibus copiis in Morinos proficiscitur, quod inde erat brevissimus in Britanniam trajectus. Huc naves undique ex finitimis regionibus, et quam superiore <sup>30</sup> aestate ad Veneticum bellum effecerat classem, jubet convenire. <sup>3</sup> Interim, consilio ejus cognito, et per mercatores perlato ad Britannos, a compluribus insulae civitatibus ad eum legati veniunt, qui polliceantur obsides dare, atque imperio populi Romani obtempe- <sup>35</sup> rare. <sup>4</sup> Quibus auditis, liberaliter pollicitus, hortatus-

que ut in ea sententia permanerent, eos domum remittit; et cum iis una Commium, quem ipse Atrebatibus superatis regem ibi constituerat, cujus et virtutem et consilium probabat, et quem sibi fidelem esse arbitrabatur, cujusque auctoritas in his regionibus magni habebatur, mittit. <sup>5</sup> Huic imperat, quas possit adeat civitates; horteturque ut populi Romani fidem sequantur, seque celeriter eo venturum nuntiet. <sup>6</sup> Volusenus, perspectis regionibus omnibus, quantum ei facultatis dari potuit, qui navi egredi ac se barbaris committere non auderet, quinto die ad Caesarem revertitur, quaeque ibi perspexisset renuntiat.

22. Dum in his locis Caesar navium parandarum causa moratur, ex magna parte Morinorum ad eum <sup>15</sup> legati venerunt, qui se de superioris temporis consilio excusarent, quod homines barbari et nostrae consuetudinis imperiti bellum populo Romano fecissent, seque ea, quae imperasset, facturos pollicerentur. <sup>2</sup> Hoc sibi Caesar satis opportune accidisse arbitratus, quod <sup>20</sup> neque post tergum hostem relinquere volebat, neque belli gerendi propter anni tempus facultatem habebat, neque has tantularum rerum occupationes Britanniae anteponendas judicabat, magnum iis numerum obsidum imperat. Quibus adductis, eos in fidem recepit. <sup>25</sup> <sup>3</sup> Navibus circiter LXXX onerariis coactis contractisque, quot satis esse ad duas transportandas legiones existimabat, quod praeterea navium longarum habebat, quaestori, legatis praefectisque distribuit. <sup>4</sup> Huc accedebant XVIII onerariae naves, quae ex eo loco ab <sup>30</sup> milibus passuum VIII vento tenebantur, quo minus in eundem portum venire possent: has equitibus distribuit. Reliquum exercitum Q. Titurio Sabino et L. Aurunculeio Cottae legatis in Menapios, atque in eos pagos Morinorum ab quibus ad eum legati non venerant, <sup>35</sup> ducendum dedit; P. Sulpicium Rufum legatum, cum eo praesidio quod satis esse arbitrabatur, portum tenere jussit.

23. His constitutis rebus, nactus idoneam ad navigandum tempestatem, tertia fere vigilia solvit, equitesque in ulteriorem portum progredi et naves conscendere et se sequi jussit. <sup>2</sup>A quibus cum paulo tardius esset administratum, ipse hora circiter diei quarta cum primis navibus Britanniam attigit, atque ibi in omnibus collibus expositas hostium copias armatas conspexit. <sup>3</sup>Cujus loci haec erat natura, atque ita montibus angustis mare continebatur, uti ex locis superioribus in litus telum adigi posset. <sup>4</sup>Hunc ad egrediendum nequaquam idoneum locum arbitratus, dum reliquae naves eo convenirent, ad horam nonam in ancoris expectavit. <sup>5</sup>Interim, legatis tribunisque militum convocatis, et quae ex Voluseno cognosset et quae fieri vellet ostendit, monuitque ut rei militaris ratio, maxime ut maritimae res postularent (ut quae celebrem atque instabilem motum haberent), ad nutum et ad tempus omnes res ab iis administrarentur. <sup>6</sup>His dimissis, et ventum et aestum uno tempore nactus secundum, dato signo et sublatis ancoris, circiter milia passuum septem ab eo loco progressus, aperto ac plano litore naves constituit.

24. At barbari, consilio Romanorum cognito, praemisso equitatu et essedariis, quo plerumque genere in proeliis uti consueverunt, reliquis copiis subsequuti, nos navibus egredi prohibebant. <sup>2</sup>Erat ob has causas summa difficultas, quod naves propter magnitudinem nisi in alto constitui non poterant; militibus autem, ignotis locis, impeditis manibus, magno et gravi onere armorum oppressis, simul et de navibus desiliendum et in fluctibus consistendum et cum hostibus erat pugnandum; cum illi aut ex arido, aut paulum in aquam progressi, omnibus membris expeditis, notissimis locis, audacter tela conicerent, et equos insuefactos incitarent. <sup>3</sup>Quibus rebus nostri perterriti, atque hujus omnino generis pugnae imperiti, non eadem alacritate

ac studio quo in pedestribus uti proeliis consuerant nitebantur.

25. Quod ubi Caesar animadvertit, naves longas, quarum et species erat barbaris inusitator, et motus ad  
5 usum expeditior, paulum removeri ab onerariis navibus, et remis incitari, et ad latus apertum hostium constitui, atque inde fundis, sagittis, tormentis hostes propelli ac summo-  
10 vereri jussit; quae res magno usui nostris fuit. <sup>2</sup> Nam, et navium figura et remorum motu et inusitato genere tormentorum permoti, barbari constiterunt, ac paulum modo pedem retulerunt. <sup>3</sup> Atque nostris militibus cunctantibus, maxime propter altitudinem maris, qui decimae legionis aquilam ferebat, contestatus deos ut ea res legioni feliciter eveniret: <sup>4</sup> *Desilite*, inquit,  
15 *milites, nisi vultis aquilam hostibus prodere: ego certe meum rei publicae atque imperatori officium praestitero.* Hoc cum voce magna dixisset, se ex navi projecit, atque in hostes aquilam ferre coepit. <sup>5</sup> Tum nostri, cohortati inter se, ne tantum dedecus  
20 admitteretur, universi ex navi desiluerunt. Hos item ex proximis [primis] navibus cum conspexissent, subsecuti hostibus adpropinquarunt.

26. Pugnatum est ab utrisque acriter. Nostri tamen, quod neque ordines servare neque firmiter insis-  
25 tere neque signa subsequi poterant, atque alius alia ex navi, quibuscumque signis occurrerat, se adgregabat, magnopere perturbabantur; <sup>2</sup> hostes vero, notis omnibus vadis, ubi ex litore aliquos singulares ex navi egredientes conspexerant, incitatis equis impeditos  
30 adoriebantur, plures paucos circumstebant, alii ab latere aperto in universos tela coniciebant. <sup>3</sup> Quod cum animadvertisset Caesar, scaphas longarum navium, item speculatoria navigia militibus compleri jussit, et quos laborantes conspexerat, his subsidia  
35 submittebat. <sup>4</sup> Nostri simul in arido constiterunt, suis omnibus consecutis, in hostes impetum fecerunt, atque

eos in fugam dederunt ; neque longius prosequi potuerunt, quod equites cursum tenere atque insulam capere non potuerant. Hoc unum ad pristinam fortunam Caesari defuit.

27. Hostes proelio superati, simul atque se ex fuga 5 receperunt, statim ad Caesarem legatos de pace miserunt ; obsides daturus quaeque imperasset facturos esse polliciti sunt. Una cum his legatis Commius Atrebas venit, quem supra demonstraveram a Caesare in Britanniam praemisum. <sup>2</sup>Hunc illi e navi egres- 10 sum, cum ad eos oratoris modo Caesaris mandata deferret, comprehenderant atque in vincula coniecerant : tum, proelio facto, remiserunt ; et in petenda pace ejus rei culpam in multitudinem contulerunt, et propter imprudentiam ut ignosceretur petiverunt. 15 <sup>3</sup>Caesar questus, quod, cum ultro in continentem legatis missis pacem ab se petissent, bellum sine causa intulissent, ignoscere imprudentiae dixit, obsidesque imperavit ; quorum illi partem statim dederunt, partem ex longinquiore locis arcessitam paucis diebus sese 20 daturus dixerunt. <sup>4</sup>Interea suos remigrare in agros jusserunt, principesque undique convenire, et se civitatesque suas Caesari commendare coeperunt.

28. His rebus pace confirmata, post diem quartum quam est in Britanniam ventum, naves XVIII, de quibus 25 supra demonstratum est, quae equites sustulerant, ex superiore portu leni vento solverunt. <sup>2</sup>Quae cum adpropinquarent Britanniae et ex castris viderentur, tanta tempestas subito coërta est, ut nulla earum cursum tenere posset ; sed aliae eodem, unde erant pro- 30 fectae, referrentur, aliae ad inferiorem partem insulae, quae est propius solis occasum, magno sui cum periculo deicerentur ; quae tamen, ancoris jactis, cum fluctibus complerentur, necessario adversa nocte in altum pro- 35 vectae continentem petierunt.

29. Eadem nocte accidit ut esset luna plena, qui

dies maritimos aestus maximos in Oceano efficere consuevit, nostrisque id erat incognitum. Ita uno tempore et longas naves, quibus Caesar exercitum transportandum curaverat, quasque in aridum subduxerat, aestus  
 5 compleverat; et onerarias, quae ad ancoras erant deligatae, tempestas adflictabat, neque ulla nostris facultas aut administrandi aut auxiliandi dabatur. <sup>2</sup>Compluribus navibus fractis, reliquae cum essent — funibus, ancoris reliquisque armamentis amissis — ad  
 10 navigandum inutiles, magna (id quod necesse erat accidere) totius exercitus perturbatio facta est. <sup>3</sup>Neque enim naves erant aliae, quibus reportari possent; et omnia deërant quae ad reficiendas naves erant usui; et, quod omnibus constabat hiemari in Gallia oportere,  
 15 frumentum his in locis in hiemem provisum non erat.

30. Quibus rebus cognitis, principes Britanniae, qui post proelium ad Caesarem convenerant, inter se conlocuti, cum equites et naves et frumentum Romanis deesse intellexerent, et paucitatem militum ex castrorum  
 20 exiguitate cognoscerent, — quae hoc erant etiam angustiora, quod sine impedimentis Caesar legiones transportaverat, — optimum factu esse duxerunt, rebellionem facta, frumento commeatuque nostros prohibere, et rem in hiemem producere; quod his superatis,  
 25 aut reditu interclusis, neminem postea belli inferendi causa in Britanniam transiturum confidebant. Itaque rursus conjuratione facta, paulatim ex castris discedere ac suos clam ex agris deducere coeperunt.

31. At Caesar, etsi nondum eorum consilia cognoverat,  
 30 verat, tamen et ex eventu navium suarum, et ex eo quod obsides dare intermiserant, fore id quod accidit suspicabatur. Itaque ad omnes casus subsidia comparabat. <sup>2</sup>Nam et frumentum ex agris cotidie in castra conferebat, et quae gravissime adflictae erant  
 35 naves, earum materia atque aere ad reliquas reficiendas utebatur; et quae ad eas res erant usui ex con-

tinenti comportari jubebat. <sup>3</sup> Itaque cum summo studio a militibus administraretur, duodecim navibus amissis, reliquis ut navigari commode posset effecit.

32. Dum ea geruntur, legione ex consuetudine una frumentatum missa, quae appellabatur septima, neque 5 ulla ad id tempus belli suspicione interposita, — cum pars hominum in agris remaneret, pars etiam in castra ventitaret, — ii qui pro portis castrorum in statione erant Caesari nuntiaverunt pulverem majorem quam consuetudo ferret in ea parte videri, quam in partem 10 legio iter fecisset. <sup>2</sup> Caesar, id quod erat suspicatus, aliquid novi a barbaris initum consilii, cohortes quae in stationibus erant secum in eam partem proficisci, ex reliquis duas in stationem cohortes succedere, reliquas armari et confestim sese subsequi jussit. <sup>3</sup> Cum 15 paulo longius a castris processisset, suos ab hostibus premi, atque aegre sustinere, et conferta legione ex omnibus partibus tela conici animadvertit. <sup>4</sup> Nam quod, omni ex reliquis partibus demesso frumento, pars una erat reliqua, suspicati hostes huc nostros esse 20 venturos, noctu in silvas delituerant; tum dispersos, depositis armis, in metendo occupatos, subito adorti, paucis interfectis, reliquos incertis ordinibus perturbaverant, simul equitatu atque essedis circumdederant.

33. Genus hoc est ex essedis pugnae. Primo per 25 omnes partes perequitant, ~~et~~ tela coniciunt, atque ipso terrore equorum et strepitu rotarum ordines plerumque perturbant; et cum se inter equitum turmas insinaverunt, ex essedis desiliunt, et pedibus proeliantur. <sup>2</sup> Aurigae interim paulatim ex proelio excedunt, atque 30 ita currus conlocant, uti si illi a multitudine hostium premantur, expeditum ad suos receptum habeant. <sup>3</sup> Ita mobilitatem equitum, stabilitatem peditum in proeliis praestant; ac tantum usu cotidiano et exercitatione efficiunt, uti in declivi ac praecipiti loco incita- 35 tos equos sustinere, et brevi moderari ac flectere, et

per temonem percurrere, et in jugo insistere, et se inde in currus citissime recipere consuerint.

34. Quibus rebus, perturbatis nostris novitate pugnae, tempore opportunissimo Caesar auxilium tulit: 5 namque ejus adventu hostes constiterunt, nostri se ex timore receperunt. <sup>2</sup> Quo facto, ad lacesendum et ad committendum proelium alienum esse tempus arbitratu, suo se loco continuit, et brevi tempore intermisso in castra legiones reduxit. <sup>3</sup> Dum haec geruntur, 10 nostris omnibus occupatis, qui erant in agris reliqui discesserunt. Secutae sunt continuos complures dies tempestates, quae et nostros in castris continerent, et hostem a pugna prohiberent. <sup>4</sup> Interim barbari nuntios in omnes partes dimiserunt, paucitatemque nostrorum 15 militum suis praedicaverunt, et quanta praedae faciendae atque in perpetuum sui liberandi facultas daretur, si Romanos castris expulissent, demonstraverunt. His rebus, celeriter magna multitudine peditatus equitatusque coacta, ad castra venerunt.

20 35. Caesar, etsi idem quod superioribus diebus acciderat fore videbat, — ut, si essent hostes pulsus, celeritate periculum effugerent, — tamen nactus equites circiter triginta, quos Commius Atrebas (de quo ante dictum est) secum transportaverat, legiones in acie 25 pro castris constituit. <sup>2</sup> Commisso proelio, diutius nostrorum militum impetum hostes ferre non potuerunt, ac terga verterunt. <sup>3</sup> Quos tanto spatio secuti, quantum cursu et viribus efficere potuerunt, complures ex iis occiderunt; deinde, omnibus longe lateque 30 aedificiis incensis, se in castra receperunt.

36. Eodem die legati ab hostibus missi ad Caesarem de pace venerunt. His Caesar numerum obsidum, quem antea imperaverat, duplicavit, eosque in continentem adduci jussit; quod, propinqua die aequinoctii, 35 infirmis navibus hiemi navigationem subiciendam non existimabat. <sup>2</sup> Ipse, idoneam tempestatem nactus,



paulo post mediam noctem naves solvit; quae omnes incolumes ad continentem pervenerunt: sed ex iis onerariae duae eosdem quos reliqui portus capere non potuerunt, et paulo infra delatae sunt.

37. Quibus ex navibus cum essent expositi milites 5 circiter trecenti, atque in castra contenderent, Morini, quos Caesar in Britanniam proficiscens pacatos reliquerat, spe praedae adducti, primo non ita magno suorum numero circumsteterunt, ac, si sese interfici nollent, arma ponere jusserunt. <sup>2</sup>Cum illi, orbe facto, 10 sese defenderent, celeriter ad clamorem hominum circiter milia sex convenerunt. Qua re nuntiata, Caesar omnem ex castris equitatum suis auxilio misit. <sup>3</sup>Interim nostri milites impetum hostium sustinuerunt, atque amplius horis quattuor fortissime pugnaverunt, 15 et paucis vulneribus acceptis complures ex his occiderunt. <sup>4</sup>Postea vero quam equitatus noster in conspectum venit, hostes abjectis armis terga verterunt, magnusque eorum numerus est occisus.

38. Caesar postero die T. Labienum legatum, cum 20 iis legionibus quas ex Britannia reducerat, in Morinos, qui rebellionem fecerant, misit. Qui cum, propter siccitates paludum, quo se reciperent non haberent (quo superiore anno perfugio fuerant usi), omnes fere in potestatem Labieni pervenerunt. <sup>2</sup>At Q. Titurius 25 et L. Cotta legati, qui in Menapiorum fines legiones duxerant, omnibus eorum agris vastatis, frumentis succisis, aedificiis incensis, quod Menapii se omnes in densissimas silvas abdiderant, se ad Caesarem receperunt. <sup>3</sup>Caesar in Belgis omnium legionum hiberna 30 constituit. Eo duae omnino civitates ex Britannia obsides miserunt, reliquae neglexerunt. His rebus gestis, ex litteris Caesaris dierum viginti supplicatio a senatu decreta est.

## BOOK V.

SECOND INVASION OF BRITAIN. — After providing for his fleet, and quieting disturbances in Illyria, Cæsar returns to Gaul (1, 2). Troubles on the northern frontier; treachery, flight, and death of Dumnorix (2-7). Cæsar's expedition lands in Britain, where the natives are driven back by the Roman cavalry (8, 9). The fleet is damaged by a storm, and hastily repaired (10, 11). Description of the island and its inhabitants (12-14). Attacks of the Britons under Cassivellaunus, who is driven beyond the Thames (15-19). Several tribes submit, and Cæsar returns to Gaul (20-23).

FRESH RISINGS OF THE GAULS. — As the Roman garrisons are widely scattered, the opportunity is seized for a sudden rising in the north, under Ambiorix (24-26). The camp of Sabinus is attacked, and imprudently forsaken; the force is attacked on the retreat, and both its commanders, Sabinus and Cotta, are slain (27-38). Ambiorix next, aided by the Nervii, attacks the camp of Quintus Cicero; he, however, holds his ground steadily, until relieved by Cæsar, who crushes the force of the Belgians (39-52). The Treveri, under Indutiomarus, attack the quarters of Labienus, but are at length repulsed, with the loss of their leader (53-58).

**L.** DOMITIO Ap. Claudio consulibus, discedens ab hibernis Caesar in Italiam, ut quotannis facere consuerat, legatis imperat quos legionibus praefererat, uti quam plurimas possent hieme naves aedificandas veteresque reficiendas curarent. Earum modum formamque demonstrat. <sup>2</sup> Ad celeritatem onerandi subductionesque, paulo facit humiliores quam quibus in nostro mari uti consuevimus; atque id eo magis, quod propter crebras commutationes aestuum minus magnos ibi fluctus fieri cogoverat; ad onera, ad multitudinem jumentorum transportandam, paulo latiores quam quibus in reliquis utimur maribus. <sup>3</sup> Has omnes actuarias imperat fieri, quam ad rem multum humilitas adjuvat. Ea quae sunt usui ad armandas naves ex Hispania appor-



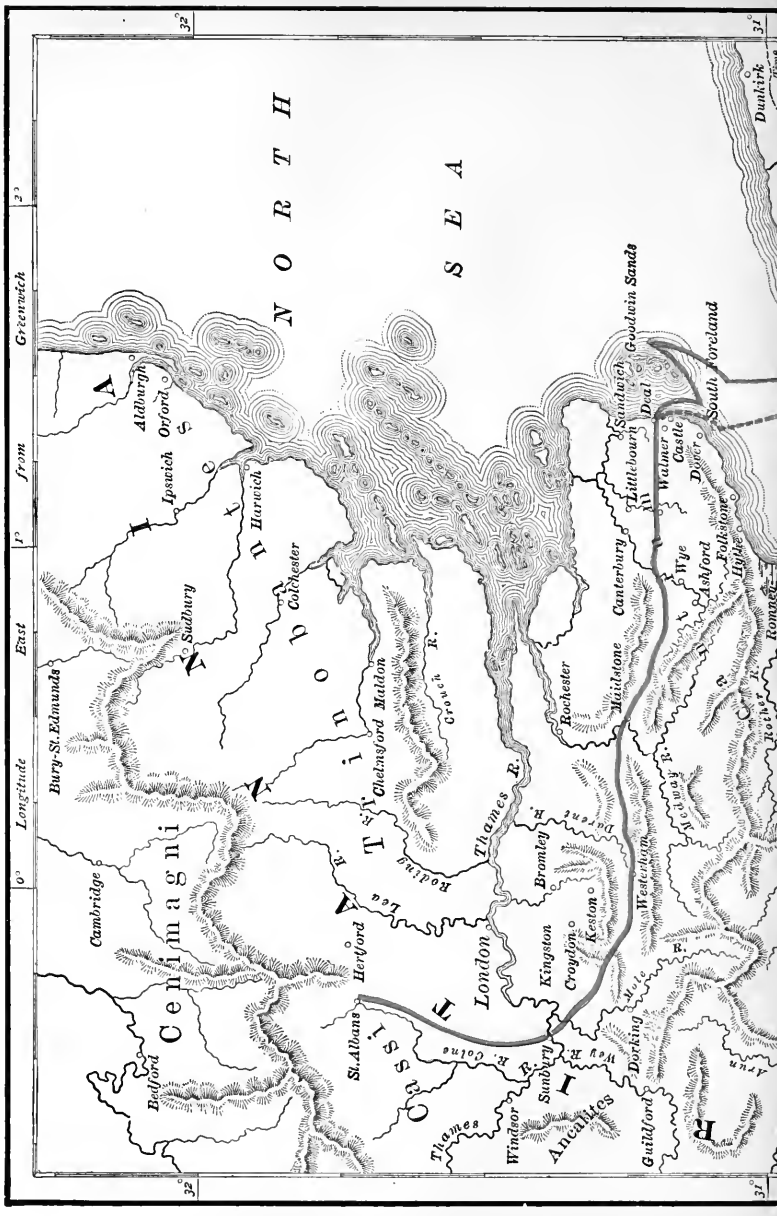

3°

Greenwich

From

East

Longitude

0°

32°

32°

N O R T H

S E A

31°

31°

Bury-St. Edmunds

Cambridge

Bedford

Cenmani

Sudbury

Aldburgh

Orford

Ipswich

Colchester

Harwich

Chelmsford

Maldon

St. Albans

Herford

Windsor

Sunbury

Ancalites

London

Kingston

Croydon

Westcham

Dorking

Guildford

Wey R.

Wey R.

Thames R.

Roding R.

Grouch R.

Bromley R.

Darent R.

Stour R.

Wey R.

Wey R.

Rochester

Maidstone

Canterbury

Littlebourne

Deal

Walmer

Castle

Dover

Wye

Ashford

Folkestone

Hythe

Rochester

Romney

Goodwin Sands

South Foreland

Dunkirk

Ypres

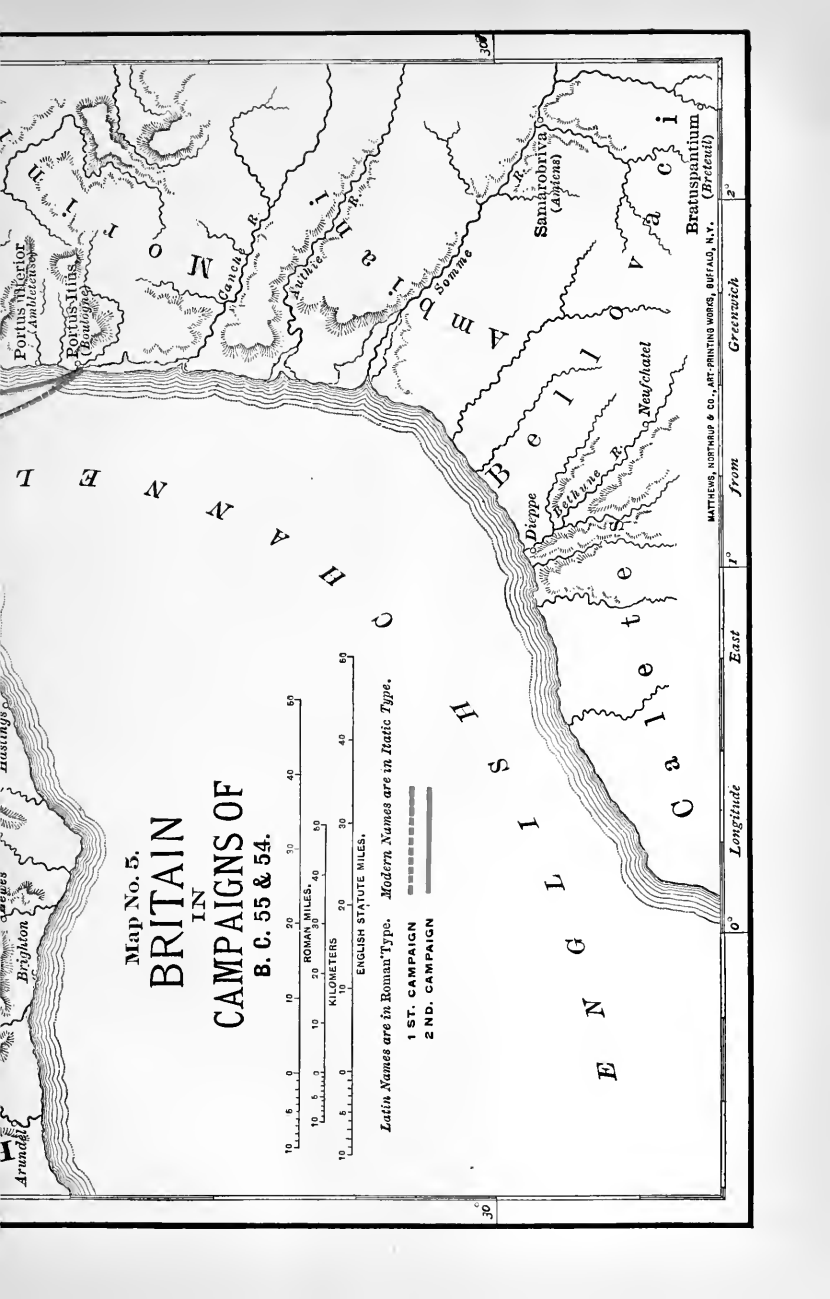

Map No. 5.  
**BRITAIN**  
 IN  
**CAMPAIGNS OF**  
**B. C. 55 & 54.**

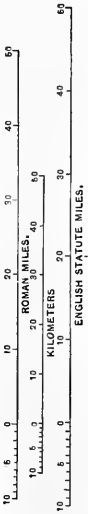

*Latin Names are in Roman Type. Modern Names are in Italic Type.*

- 1 ST. CAMPAIGN
- 2 ND. CAMPAIGN

MATTHEWS, NORTHRUP & CO., ART-PRINTING WORKS, BUFFALO, N.Y.  
 (Breiten!)  
 from Greenwich

Longitude East 0° 1° 2°



tari jubet. <sup>4</sup> Ipse, conventibus Galliae citerioris peractis, in Illyricum proficiscitur, quod a Pirustis finitimam partem provinciae incursionibus vastari audiebat. Eo cum venisset, civitatibus milites imperat certumque in locum convenire jubet. <sup>5</sup> Qua re nuntiata, Pirustae legatos ad eum mittunt, qui doceant nihil earum rerum publico factum consilio, seseque paratos esse demonstrant omnibus rationibus de injuriis satisfacere. <sup>6</sup> Percepta oratione eorum, Caesar obsides imperat eosque ad certam diem adduci jubet: nisi ita fecerint, sese bello civitatem persecuturum demonstrat. <sup>7</sup> Iis ad diem adductis, ut imperaverat, arbitros inter civitates dat, qui litem aestiment poenamque constituent.

2. His confectis rebus conventibusque peractis, in citeriorem Galliam revertitur, atque inde ad exercitum proficiscitur. <sup>2</sup> Eo cum venisset, circuitis omnibus hibernis, singulari militum studio, in summa omnium rerum inopia, circiter sexcentas ejus generis cujus supra demonstravimus naves et longas xxviii invenit instructas, neque multum abesse ab eo, quin paucis diebus deduci possent. <sup>3</sup> Collaudatis militibus atque iis qui negotio praefuerant, quid fieri velit ostendit, atque omnes ad portum Itium convenire jubet, quo ex portu commodissimum in Britanniam trajectum esse cognoverat circiter milium passuum triginta a continenti. <sup>4</sup> Huic rei quod satis esse visum est militum reliquit: ipse cum legionibus expeditis iv, et equitibus dccc, in fines Treverorum proficiscitur; quod hi neque ad concilia veniebant, neque imperio parebant, Germanosque Transrhenanos sollicitare dicebantur.

3. Haec civitas longe plurimum totius Galliae equitatu valet, magnasque habet copias peditum, Rhenumque, ut supra demonstravimus, tangit. <sup>2</sup> In ea civitate duo de principatu inter se contendebant, Indutiomarus et Cingetorix; ex quibus alter, simul atque de Caesaris legionumque adventu cognitum est, ad eum venit; se suosque

omnes in officio futuros, neque ab amicitia populi Romani defecturos, confirmavit; quaeque in Treveris gererentur ostendit. <sup>3</sup> At Indutiomarus equitatum peditatumque cogere, iisque qui per aetatem in armis esse non poterant  
 5 in silvam Arduennam abditis, quae ingenti magnitudine per medios fines Treverorum a flumine Rheno ad initium Remorum pertinet, bellum parare instituit. <sup>4</sup> Sed, posteaquam nonnulli principes ex ea civitate, et familiaritate Cingetorigis adducti et adventu nostri exercitus  
 10 perterriti, ad Caesarem venerunt, et de suis privatim rebus ab eo petere coeperunt, quoniam civitati consulere non possent; <sup>5</sup> veritus ne ab omnibus desereretur, Indutiomarus legatos ad Caesarem mittit: 'Sese idcirco ab suis discedere atque ad eum venire noluisse, quo facilius  
 15 civitatem in officio contineret, ne omnis nobilitatis discessu plebs propter imprudentiam laberetur; itaque esse civitatem in sua potestate, seque, si Caesar permetteret, ad eum in castra venturum, suas civitatisque fortunas ejus fidei permissurum.'

20 4. Caesar, etsi intellegebat qua de causa ea dicerentur, quaeque eum res ab instituto consilio deterreret, tamen, ne aestatem in Treveris consumere cogeretur, omnibus ad Britannicum bellum rebus comparatis, Indutiomarus ad se cum ducentis obsidibus venire jussit. <sup>2</sup> His adductis, in iis filio propinquisque ejus omnibus, quos nominatim evocaverat, consolatus Indutiomarus, hortatusque est uti in officio permaneret; nihilo tamen secius, principibus Treverorum ad se convocatis, hos singillatim Cingetorigi conciliavit; <sup>3</sup> quod cum merito ejus a se fieri  
 30 intellegebat, tum magni interesse arbitrabatur ejus auctoritatem inter suos quam plurimum valere, cujus tam egregiam in se voluntatem perspexisset. <sup>4</sup> Id tulit factum graviter Indutiomarus, suam gratiam inter suos minui; et, qui jam ante inimico in nos animo fuisset, multo  
 35 gravius hoc dolore exarsit.

5. His rebus constitutis, Caesar ad portum Itium cum



legionibus pervenit. <sup>2</sup> Ibi cognoscit sexaginta naves, quae in Meldis factae erant, tempestate rejectas cursum tenere non potuisse, atque eodem unde erant profectae revertisse; reliquas paratas ad navigandum atque omnibus rebus instructas invenit. <sup>3</sup> Eodem equitatus totius Galliae convenit, numero milium quattuor, principesque omnibus ex civitatibus; ex quibus perpauca, quorum in se fidem perspexerat, relinquere in Gallia, reliquos obsidum loco secum ducere decreverat, quod, cum ipse abesset, motum Galliae verebatur. 10

6. Erat una cum ceteris Dumnorix Haeduus, de quo ante ab nobis dictum est. Hunc secum habere in primis constituerat, quod eum cupidum rerum novarum, cupidum imperii, magni animi, magnae inter Gallos auctoritatis, cognoverat. <sup>2</sup> Accedebat huc, quod in concilio Haeduorum Dumnorix dixerat, sibi a Caesare regnum civitatis deferri: quod dictum Haedui graviter ferebant, neque recusandi aut deprecandi causa legatos ad Caesarem mittere audebant. <sup>3</sup> Id factum ex suis hospitibus Caesar cognoverat. Ille omnibus primo precibus petere contendit, ut in Gallia relinqueretur: partim quod insuetus navigandi mare timeret, partim quod religionibus impediri sese diceret. <sup>4</sup> Posteaquam id obstinate sibi negari vidit, omni spe impetrandi adempta, principes Galliae sollicitare, sevocare singulos, hortarique coepit, uti in continenti remanerent; metu territare, non sine causa fieri, ut Gallia omni nobilitate spoliaretur; <sup>5</sup> id esse consilium Caesaris, ut, quos in conspectu Galliae interficere vereretur, hos omnes in Britanniam traductos necaret; fidem reliquis interponere, jusjurandum poscere, ut, quod esse ex usu Galliae intellexissent, communi consilio administrarent. Haec a compluribus ad Caesarem deferebantur. 20 25 30

7. Qua re cognita, Caesar, quod tantum civitati Haeduae dignitatis tribuebat, coercendum atque deterrendum quibuscumque rebus posset Dumnorigem statuebat; 35

quod longius ejus amentiam progredi videbat, prospiciendum ne quid sibi ac reipublicae nocere posset. <sup>2</sup> Itaque, dies circiter xxv in eo loco commoratus, quod Corus ventus navigationem impediēbat, qui magnam  
 5 partem omnis temporis in his locis flare consuevit, dabat operam, ut in officio Dumnorigem contineret; nihilo tamen secius omnia ejus consilia cognosceret. <sup>3</sup> Tandem, idoneam nactus tempestatem, milites equitesque conscendere in naves jubet. At, omnium impeditis animis,  
 10 Dumnorix cum equitibus Haeduorum a castris, insciente Caesare, domum discedere coepit. <sup>4</sup> Qua re nuntiata, Caesar, intermissa profectioe, atque omnibus rebus postpositis, magnam partem equitatus ad eum insequendum mittit, retrahique imperat; si vim faciat neque  
 15 pareat, interfici jubet; nihil hunc se absente pro sano facturum arbitratus, qui praesentis imperium neglexisset. <sup>5</sup> Ille enim, revocatus, resistere ac se manu defendere suorumque fidem implorare coepit, saepe clamitans, liberum se liberaeque esse civitatis. <sup>6</sup> Illi, ut erat imperatum, circumsistunt hominem atque interficiunt: at  
 20 equites Haedui ad Caesarem omnes revertuntur.

8. His rebus gestis, Labieno in continente cum tribus legionibus et equitum milibus duobus relicto, ut portus tueretur et rem frumentariam provideret, quaeque in  
 25 Gallia gererentur cognosceret, consiliumque pro tempore et pro re caperet, <sup>2</sup> ipse cum quinque legionibus, et pari numero equitum, quem in continenti relinquerat, ad solis occasum naves solvit; et leni Africo provectus, media circiter nocte vento intermisso, cursum non tenuit; et, longius delatus aestu, orta luce, sub sinistra  
 30 Britanniam relictam conspexit. <sup>3</sup> Tum rursus aestus commutationem secutus, remis contendit ut eam partem insulae caperet, qua optimum esse egressum superiore aestate cognoverat. <sup>4</sup> Qua in re admodum fuit militum  
 35 virtus laudanda, qui vectoriis gravibusque navigiis, non intermisso remigandi labore, longarum navium cursum

adaequarunt. <sup>5</sup> Accessum est ad Britanniam omnibus navibus meridiano fere tempore: neque in eo loco hostis est visus, sed, ut postea Caesar ex captivis cognovit, cum magnae manus eo convenissent, multitudine navium perterritae, quae cum annotinis privatisque, quas sui quisque commodi fecerat, amplius octingentae uno erant visae tempore, a litore discesserant ac se in superiora loca abdiderant.

9. Caesar, exposito exercitu et loco castris idoneo capto, ubi ex captivis cognovit quo in loco hostium copiae consedissent, cohortibus decem ad mare relictis, et equitibus ccc, qui praesidio navibus essent, de tertia vigilia ad hostes contendit, — eo minus veritus navibus, quod in litore molli atque aperto deligatas ad ancoram relinquebat, — et praesidio navibus Q. Atrium praefecit.

<sup>2</sup> Ipse, noctu progressus milia passuum circiter XII, hostium copias conspicatus est. Illi, equitatu atque essedis ad flumen progressi, ex loco superiore nostros prohibere et proelium committere coeperunt. <sup>3</sup> Repulsi ab equitatu, se in silvas abdiderunt, locum nacti egregie et natura et opere munitum, quem domestici belli (ut videbantur) causa jam ante praeparaverant; nam crebris arboribus succisis omnes introitus erant praeclusi. <sup>4</sup> Ipsi ex silvis rari propugnabant, nostrosque intra munitiones ingredi prohibebant. At milites legionis septimae, testudine facta et aggere ad munitiones adjecto, locum ceperunt eosque ex silvis expulerunt, paucis vulneribus acceptis.

<sup>5</sup> Sed eos fugientes longius Caesar prosequi vetuit, et quod loci naturam ignorabat, et quod, magna parte diei consumpta, munitioni castrorum tempus relinquere volebat.

10. Postridie ejus diei, mane, tripartito milites equitesque in expeditionem misit, ut eos qui fugerant persequerentur. <sup>2</sup> His aliquantum itineris progressis, cum jam extremi essent in prospectu, equites a Q. Atrio ad Caesarem venerunt, qui nuntiarent superiore nocte, maxima coërta tempestate, prope omnes naves afflictas

atque in litore ejectas esse ; quod neque ancorae funesque subsisterent, neque nautae gubernatoresque vim tempestatis pati possent. <sup>3</sup> Itaque ex eo concursu navium magnum esse incommodum acceptum.

5 11. His rebus cognitis, Caesar legiones equitatumque revocari atque in itinere desistere jubet ; ipse ad naves revertitur : eadem fere, quae ex nuntiis litterisque cognoverat, coram perspicit, sic ut, amissis circiter XL navibus, reliquae tamen refici posse magno negotio  
10 viderentur. <sup>2</sup> Itaque ex legionibus fabros deligit, et ex continenti alios arcessi jubet ; Labieno scribit ut quam plurimas posset, iis legionibus quae sunt apud eum, naves instituat. <sup>3</sup> Ipse, etsi res erat multae operae ac laboris, tamen commodissimum esse statuit, omnes  
15 naves subduci et cum castris una munitione conjungi. <sup>4</sup> In his rebus circiter dies decem consumit, ne nocturnis quidem temporibus ad laborem militum intermissis. Subductis navibus castrisque egregie munitis, easdem copias quas ante praesidio navibus reliquit ; ipse eodem  
20 unde redierat proficiscitur. <sup>5</sup> Eo cum venisset, majores jam undique in eum locum copiae Britannorum convenerant ; summa imperii bellique administrandi, communi consilio, permissa Cassivellauno, cujus fines a maritimis civitatibus flumen dividit, quod appellatur  
25 Tamesis, a mari circiter milia passuum LXXX. <sup>6</sup> Huic superiore tempore cum reliquis civitatibus continentia bella intercesserant ; sed nostro adventu permoti Britannii hunc toti bello imperioque praefecerant.

12. Britanniae pars interior ab iis incolitur, quos natos  
30 in insula ipsi memoria proditum dicunt ; maritima pars ab iis qui, praedae ac belli inferendi causa, ex Belgis transierunt (qui omnes fere iis nominibus civitatum appellantur, quibus orti ex civitatibus eo pervenerunt) et bello illato ibi remanserunt, atque agros colere coeperunt.  
35 <sup>2</sup> Hominum est infinita multitudo, creberrimaeque aedificia fere Gallicis consimilia ; pecorum magnus nu-

merus. <sup>3</sup> Utuntur aut aere [aut nummo aereo] aut taleis ferreis ad certum pondus examinatis pro nummo. Nas-  
citur ibi plumbum album in mediterraneis regionibus, in  
maritimis ferrum, sed ejus exigua est copia; aere utun-  
tur importato. <sup>4</sup> Materia cujusque generis ut in Gallia 5  
est praeter fagum atque abietem. Leporem et gallinam  
et anserem gustare fas non putant; haec tamen alunt  
animi voluptatisque causa. Loca sunt temperatiora  
quam in Gallia, remissioribus frigoribus.

13. Insula natura triquetra, cujus unum latus est <sup>10</sup>  
contra Galliam. Hujus lateris alter angulus, qui est ad  
Cantium, quo fere omnes ex Gallia naves appelluntur, ad  
orientem solem; inferior ad meridiem spectat. Hoc per-  
tinet circiter milia passuum quingenta. <sup>2</sup> Alterum vergit  
ad Hispaniam atque occidentem solem; qua ex parte <sup>15</sup>  
est Hibernia, dimidio minor (ut aestimatur) quam Bri-  
tannia, sed pari spatio transmissus atque ex Gallia est  
in Britanniam. <sup>3</sup> In hoc medio cursu est insula quae  
appellatur Mona; complures praeterea minores sub-  
jectae insulae existimantur; de quibus insulis nonnulli <sup>20</sup>  
scripserunt, dies continuos xxx sub bruma esse noctem.  
<sup>4</sup> Nos nihil de eo percontationibus reperiebamus, nisi cer-  
tis ex aqua mensuris breviores esse quam in continenti  
noctes videbamus. Hujus est longitudo lateris, ut fert  
illorum opinio, dcc milium. <sup>5</sup> Tertium est contra sep- <sup>25</sup>  
tentriones, cui parti nulla est objecta terra; sed ejus  
angulus lateris maxime ad Germaniam spectat. Hoc  
milia passuum dccc in longitudinem esse existimatur.  
Ita omnis insula est in circuitu vicies centum milium  
passuum. <sup>30</sup>

14. Ex his omnibus longe sunt humanissimi qui  
Cantium incolunt (quae regio est maritima omnis),  
neque multum a Gallica differunt consuetudine. <sup>2</sup> In-  
teriores plerique frumenta non serunt, sed lacte et carne  
vivunt, pellibusque sunt vestiti. <sup>3</sup> Omnes vero se Bri- <sup>35</sup>  
tanni vitro inficiunt, quod caeruleum efficit colorem,

atque hoc horridiores sunt in pugna aspectu; capilloque sunt promisso, atque omni parte corporis rasa praeter caput et labrum superius. <sup>4</sup> Uxores habent deni duode-nique inter se communes, et maxime fratres cum fratri-  
 5 bus, parentesque cum liberis; sed qui sunt ex his nati, eorum habentur liberi, quo primum virgo quaeque de-ducta est.

15. Equites hostium essedariiue acriter proelio cum equitatu nostro in itinere conflixerunt, [ita] tamen ut  
 10 nostri omnibus partibus superiores fuerint atque eos in silvas collesque compulerint; sed, compluribus inter-  
 15fectis, cupidius insecuti, nonnullos ex suis amiserunt. <sup>2</sup> At illi, intermisso spatio, imprudentibus nostris atque occupatis in munitione castrorum, subito se ex silvis  
 20 ejecerunt, impetuque in eos facto qui erant in statione pro castris collocati, acriter pugnaverunt; <sup>3</sup> duabusque missis subsidio cohortibus a Caesare, atque his primis legionum duarum, cum hae, perexiguo intermisso [loci]  
 25 spatio inter se, constitissent, novo genere pugnae per-  
 30 territis nostris, per medios audacissime perruperunt, seque inde incolumes receperunt. <sup>4</sup> Eo die Q. Laberius Durus tribunus militum interficitur. Illi, pluribus sub-  
 missis cohortibus, repelluntur.

16. Toto hoc in genere pugnae, cum sub oculis  
 25 omnium ac pro castris dimicaretur, intellectum est nostros, propter gravitatem armorum, quod neque inse-  
 qui cedentes possent neque ab signis discedere auderent, minus aptos esse ad hujus generis hostem; <sup>2</sup> equites  
 30 autem magno cum periculo dimicare, propterea quod  
 illi etiam consulto plerumque cederent, et cum paulum ab legionibus nostros removissent, ex essedis desilirent  
 et pedibus dispari proelio contenderent. <sup>3</sup> Equestris au-  
 tem proelii ratio et cedentibus et insequentibus par  
 atque idem periculum inferebat. <sup>4</sup> Accedebat huc, ut  
 35 nunquam conferti sed rari magnisque intervallis proe-  
 liarentur, stationesque dispositas haberent, atque alios

alii deinceps exciperent, integrique et recentes defatigatis succederent.

17. Postero die procul a castris hostes in collibus constiterunt, rarique se ostendere, et lenius quam pridie nostros equites proelio lacessere coeperunt. <sup>2</sup> Sed meri- 5 die, cum Caesar pabulandi causa tres legiones atque omnem equitatum cum C. Trebonio legato misisset, repente ex omnibus partibus ad pabulatores advolaverunt, sic uti ab signis legionibusque non absisterent. <sup>3</sup> Nostri, acriter in eos impetu facto, repulerunt, neque 10 finem sequendi fecerunt, quoad subsidio confisi equites, cum post se legiones viderent, praecipites hostes egerunt; magnoque eorum numero interfecto, neque sui colligendi neque consistendi aut ex essedis desiliendi facultatem dederunt. <sup>4</sup> Ex hac fuga protinus quae un- 15 dique convenerant auxilia discesserunt; neque post id tempus umquam summis nobiscum copiis hostes contenderunt.

18. Caesar, cognito consilio eorum, ad flumen Tamesim in fines Cassivellauni exercitum duxit; quod flumen 20 uno omnino loco pedibus, atque hoc aegre, transiri potest. <sup>2</sup> Eo cum venisset, animum advertit ad alteram fluminis ripam magnas esse copias hostium instructas; ripa autem erat acutis sudibus praefixis munita, ejusdemque generis sub aqua defixae sudes flumine tege- 25 bantur. <sup>3</sup> His rebus cognitis a captivis perfugisque, Caesar, praemisso equitatu, confestim legiones subsequi jussit. <sup>4</sup> Sed ea celeritate atque eo impetu milites ierunt, cum capite solo ex aqua exstarent, ut hostes impetum legionum atque equitum sustinere non pos- 30 sent, ripasque dimitterent ac se fugae mandarent.

19. Cassivellaunus, ut supra demonstravimus, omni deposita spe contentionis, dimissis amplioribus copiis, milibus circiter quattuor essedariorum relictis, itinera nostra servabat; paulumque ex via excedebat, locisque 35 impeditis ac silvestribus sese occultabat, atque iis re-

gionibus quibus nos iter facturos cognoverat pecora atque homines ex agris in silvas compellebat; <sup>2</sup> et cum equitatus noster liberius praedandi vastandique causa se in agros ejecerat, omnibus viis semitisque essedarios  
 5 ex silvis emittebat; et magno cum periculo nostrorum equitum cum iis confligebat, atque hoc metu latius vagari prohibebat. <sup>3</sup> Relinquebatur ut neque longius ab agmine legionum discedi Caesar pateretur, et tantum in agris vastandis incendiisque faciendis hostibus noceret-  
 10 tur, quantum labore atque itinere legionarii milites efficere poterant.

20. Interim Trinobantes, prope firmissima earum regionum civitas, ex qua Mandubracius adulescens, Caesaris fidem secutus, ad eum in continentem Galliam  
 15 venerat, —cujus pater [Imanuentius] in ea civitate regnum obtinuerat, interfectusque erat a Cassivellauno; ipse fuga mortem vitaverat, — legatos ad Caesarem mittunt, pollicenturque sese ei dedituros atque imperata facturos: <sup>2</sup>  
 20 petunt ut Mandubracium ab injuria Cassivellauni defendat, atque in civitatem mittat, qui praesit imperiumque obtineat. <sup>3</sup> His Caesar imperat obsides XL frumentumque exercitui, Mandubraciumque ad eos mittit. Illi imperata celeriter fecerunt, obsides ad numerum frumentumque miserunt.

25 21. Trinobantibus defensis atque ab omni militum injuria prohibitis, Icani, Cangi, Segontiaci, Ancalites, Bibroci, Cassi, legationibus missis, sese Caesari dedunt. Ab his cognoscit, non longe ex eo loco oppidum Cassivellauni abesse, silvis paludibusque munitum, quo satis  
 30 magnus hominum pecorisque numerus convenerit. <sup>2</sup> Oppidum autem Britanni vocant, cum silvas impeditas vallo atque fossa munerunt, quo incursionis hostium vitandae causa convenire consuerunt. <sup>3</sup> Eo proficiscitur cum legionibus; locum reperit egregie natura atque  
 35 opere munitum; tamen hunc duabus ex partibus oppugnare contendit. Hostes paulisper morati militum



nostrorum impetum non tulerunt, seseque alia ex parte oppidi ejecerunt. <sup>4</sup> Magnus ibi numerus pecoris repertus; multique in fuga sunt comprehensi atque interfecti.

22. Dum haec in his locis geruntur, Cassivellaunus ad 5 Cantium, quod esse ad mare supra demonstravimus, quibus regionibus quattuor reges praeerant, Cingetorix, Carvilius, Taximagulus, Segovax, nuntios mittit, atque his imperat uti, coactis omnibus copiis, castra navalia de improvise adoriantur atque oppugnent. <sup>2</sup> Ii cum ad cas- 10 tra venissent, nostri, eruptione facta, multis eorum interfectis, capto etiam nobili duce Lugotorige, suos incolumes reduxerunt. <sup>3</sup> Cassivellaunus, hoc proelio nuntiato, tot detrimentis acceptis, vastatis finibus, maxime etiam permotus defectione civitatum, legatos per Atrebatem 15 Commium de deditioe ad Caesarem mittit. <sup>4</sup> Caesar cum constituisset hiemare in continenti propter repentinos Galliae motus, neque multum aestatis superesset, atque id facile extrahi posse intellegeret, obsides imperat; et quid in annos singulos vectigalis populo Romano 20 Britannia penderet constituit. <sup>5</sup> Interdicit atque imperat Cassivellauno, ne Mandubraccio neu Trinobantibus bellum faciat.

23. Obsidibus acceptis, exercitum reducit ad mare, naves invenit refectas. His deductis, quod et captivo- 25 rum magnum numerum habebat, et nonnullae tempestate deperierant naves, duobus commeatibus exercitum reportare instituit. <sup>2</sup> Ac sic accidit, uti ex tanto navium numero, tot navigationibus, neque hoc neque superiore anno ulla omnino navis quae milites portaret desideraretur; <sup>3</sup> at ex iis quae inanes ex continenti ad eum remitterentur, et prioris commeatus expositis militibus, et quas postea Labienus faciendas curaverat numero LX, perpaucae locum caperent; reliquae fere omnes reicerentur. <sup>4</sup> Quas cum aliquamdiu Caesar frustra ex- 35 spectasset, ne anni tempore a navigatione excluderetur,

quod aequinoctium suberat, necessario angustius milites collocavit, ac, summa tranquillitate consecuta, secunda inita cum solvisset vigilia, prima luce terram attigit, omnesque incolumes naves perduxit.

5 24. Subductis navibus concilioque Gallorum Samarbrivæ peracto, quod eo anno frumentum in Gallia propter siccitates angustius provenerat, coactus est aliter ac superioribus annis exercitum in hibernis collocare, legionesque in plures civitates distribuere: <sup>2</sup>ex quibus  
10 unam in Morinos ducendam C. Fabio legato dedit; alteram in Nervios Q. Ciceroni; tertiam in Esvios L. Roscio; quartam in Remis cum T. Labieno in confinio Treverorum hiemare jussit; tres in Belgis collocavit: his M. Crassum quaestorem et L. Munatium  
15 Plancum et C. Trebonium legatos praeficit. <sup>3</sup>Unam legionem, quam proxime trans Padum conscripserat, et cohortes quinque in Eburones, quorum pars maxima est inter Mosam ac Rhenum, qui sub imperio Ambiorigis et Catuvolci erant, misit. <sup>4</sup>His militibus Q. Titurium  
20 Sabinum et L. Aurunculeium Cottam legatos praeesse jussit. Ad hunc modum distributis legionibus, facillime inopiae frumentariae sese mederi posse existimavit. <sup>5</sup>Atque harum tamen omnium legionum hiberna, praeter eam quam L. Roscio in pacatissimam et quietissimam  
25 partem ducendam dederat, milibus passuum centum continebantur. <sup>6</sup>Ipse interea, quoad legiones collocatas munitaque hiberna cognovisset, in Gallia morari constituit.

25. Erat in Carnutibus summo loco natus Tasgetius,  
30 cujus majores in sua civitate regnum obtinuerant. Huic Caesar, pro ejus virtute atque in se benevolentia, quod in omnibus bellis singulari ejus opera fuerat usus, majorum locum restituerat. <sup>2</sup>Tertium jam hunc annum regnantem, inimicis multis palam ex civitate et iis auctoribus, eum interfecerunt. Defertur ea res ad Caesarem.  
35 <sup>3</sup>Ille veritus, quod ad plures pertinebat, ne civitas eorum

impulsu deficeret, L. Plancum cum legione ex Belgio celeriter in Carnutes proficisci jubet ibique hiemare; quorumque opera cognoverit Tasgetium interfectum, hos comprehensos ad se mittere. <sup>4</sup>Interim ab omnibus legatis quaestoreque, quibus legiones tradiderat, certior <sup>5</sup> factus est in hiberna perventum, locumque hibernis esse munitum.

26. Diebus circiter quindecim, quibus in hiberna ventum est, initium repentini tumultus ac defectionis ortum est ab Ambiorige et Catuvolco; qui, cum ad fines regni <sup>10</sup> sui Sabino Cottaque praesto fuissent, frumentumque in hiberna comportavissent, Indutiomari Treveri nuntiis impulsus, suos concitaverunt, subitoque oppressis lignatoribus, magna manu castra oppugnatum venerunt. <sup>2</sup>Cum celeriter nostri arma cepissent vallumque adscendissent, <sup>15</sup> atque, una ex parte Hispanis equitibus emissis, equestri proelio superiores fuissent, desperata re hostes suos ab oppugnatione reduxerunt. <sup>3</sup>Tum suo more conclamaverunt, uti aliqui ex nostris ad colloquium prodiret; habere sese quae de re communi dicere vellent, quibus <sup>20</sup> rebus controversias minui posse sperarent.

27. Mittitur ad eos colloquendi causa C. Arpineius, eques Romanus, familiaris Q. Titurii, et Q. Junius ex Hispania quidam, qui jam ante missu Caesaris ad Ambiorigem ventitare consueverat; <sup>2</sup>apud quos Ambiorix <sup>25</sup> ad hunc modum locutus est: 'Sese pro Caesaris in se beneficiis plurimum ei confiteri debere, quod ejus opera stipendio liberatus esset quod Aduatucis, finitimis suis, pendere consuesset, quodque ei et filius et fratris filius ab Caesare remissi essent quos Aduatuci, obsidum nu- <sup>30</sup> mero missos, apud se in servitute et catenis tenuissent; <sup>3</sup>neque id quod fecerit de oppugnatione castrorum, aut iudicio aut voluntate sua fecisse, sed coactu civitatis; suaque esse ejusmodi imperia, ut non minus haberet juris in se multitudo quam ipse in multitudinem. <sup>4</sup>Civi- <sup>35</sup> tati porro hanc fuisse belli causam, quod repentinae

Gallorum conjurationi resistere non potuerit; id se facile ex humilitate sua probare posse, quod non adeo sit imperitus rerum ut suis copiis populum Romanum se superare posse confidat. <sup>5</sup> Sed esse Galliae commune consilium; omnibus hibernis Caesaris oppugnandis hunc esse dictum diem, ne qua legio alterae legioni subsidio venire posset; non facile Gallos Gallis negare potuisse, praesertim cum de recuperanda communi libertate consilium initum videretur. <sup>6</sup> Quibus quoniam pro pietate

10 satisfecerit, habere nunc se rationem officii pro beneficiis Caesaris; monere, orare Titurium pro hospitio, ut suae ac militum saluti consulat. Magnam manum Germanorum conductam Rhenum transisse; hanc adfore biduo. <sup>7</sup> Ipsorum esse consilium, velintne prius quam finitimi

15 sentiant, eductos ex hibernis milites aut ad Ciceronem aut ad Labienum deducere, quorum alter milia passuum circiter quinquaginta, alter paulo amplius ab iis absit. <sup>8</sup> Illud se polliceri et jurejurando confirmare, tutum iter per fines suos daturum; quod cum faciat, et civitati sese

20 consulere quod hibernis levetur, et Caesari pro ejus meritis gratiam referre.' Hac oratione habita, discedit Ambiorix.

28. Arpineius et Junius quae audierunt ad legatos deferunt. Illi repentina re perturbati, etsi ab hoste ea

25 dicebantur, tamen non neglegenda existimabant; maximeque hac re permovebantur, quod civitatem ignobilem atque humilem Eburonum sua sponte populo Romano bellum facere ausam vix erat credendum. <sup>2</sup> Itaque ad consilium rem deferunt; magnaque inter eos existit

30 controversia. L. Aurunculeius compluresque tribuni militum et primorum ordinum centuriones nihil temere agendum, neque ex hibernis injussu Caesaris discedendum existimabant: <sup>3</sup> quantasvis magnas etiam copias Germanorum sustineri posse munitis hibernis docebant; rem

35 esse testimonio, quod primum hostium impetum, multis ultro vulneribus illatis, fortissime sustinuerint: <sup>4</sup> re fru-

mentaria non premi ; interea et ex proximis hibernis et a Caesare conventura subsidia ; postremo, quid esse levius aut turpius, quam auctore hoste de summis rebus capere consilium ?

29. Contra ea Titurius 'sero facturos' clamitabat, 'cum 5 majores manus hostium, adjunctis Germanis, convenissent ; aut cum aliquid calamitatis in proximis hibernis esset acceptum. Brevem consulendi esse occasionem :<sup>2</sup> Caesarem arbitrari profectum in Italiam ; neque aliter Carnutes interficiendi Tasgetii consilium fuisse captu- 10 ros, neque Eburones, si ille adesset, tanta contemptione nostri ad castra venturos esse. <sup>3</sup> Non hostem auctorem sed rem spectare ; subesse Rhenum ; magno esse Germanis dolori Ariovisti mortem et superiores nostras victorias ; ardere Galliam, tot contumeliis acceptis, sub 15 populi Romani imperium redactam, superiore gloria rei militaris exstincta. <sup>4</sup> Postremo, quis hoc sibi persuaderet, sine certa re Ambiorigem ad ejusmodi consilium descendisse ? Suam sententiam in utramque partem esse tutam : si nihil esset durius, nullo cum periculo ad 20 proximam legionem perventuros ; si Gallia omnis cum Germanis consentiret, unam esse in celeritate positam salutem. <sup>5</sup> Cottae quidem, atque eorum qui dissentirent, consilium quem habere exitum ? in quo si non praesens periculum, at certe longinqua obsidione fames 25 esset timenda.'

30. Hac in utramque partem disputatione habita, cum a Cotta primisque ordinibus acriter resisteretur ; "Vincite," inquit, "si ita vultis," Sabinus, et id clariore voce, ut magna pars militum exaudiret : <sup>2</sup>"neque is sum," in- 30 quit, "qui gravissime ex vobis mortis periculo terrear : hi sapient ; si gravius quid acciderit, abs te rationem reposcent ; <sup>3</sup> qui, si per te liceat, perendino die cum proximis hibernis conjuncti, communem cum reliquis belli casum sustineant, non rejecti et relegati longe ab 35 ceteris aut ferro aut fame intereant."

31. Consurgitur ex consilio ; comprehendunt utrumque, et orant, ‘Ne sua dissensione et pertinacia rem in summum periculum deducant ; facilem esse rem, seu maneat, seu proficiscantur, si modo unum omnes sentiant  
5 ac probent ; contra in dissensione nullam se salutem perspicere.’ <sup>2</sup> Res disputatione ad mediam noctem perducitur. Tandem dat Cotta permotus manus ; superat sententia Sabini. Pronuntiatur prima luce ituros. <sup>3</sup> Consumitur vigiliis reliqua pars noctis, cum sua quisque miles  
10 cumspiceret, quid secum portare posset, quid ex instrumento hibernorum relinquere cogeretur. Omnia excogitantur, quare nec sine periculo maneatur, et languore militum et vigiliis periculum augeatur. <sup>4</sup> Prima  
15 luce sic ex castris proficiscuntur ut quibus esset persuasum, non ab hoste sed ab homine amicissimo Amborige consilium datum, longissimo agmine maximisque impedimentis.

32. At hostes, posteaquam ex nocturno fremitu vigiliisque de profectione eorum senserunt, collocatis insidiis  
20 bipartito in silvis opportuno atque occulto loco, a milibus passuum circiter duobus, Romanorum adventum expectabant ; <sup>2</sup> et cum se major pars agminis in magnam convallem demisisset, ex utraque parte ejus vallis subito se ostenderunt, novissimosque premere et primos  
25 prohibere ascensu, atque iniquissimo nostris loco proelium committere coeperunt.

33. Tum demum Titurius, qui nihil ante providisset, trepidare et concursare cohortesque disponere ; haec tamen ipsa timide atque ut eum omnia deficere viderentur ;  
30 quod plerumque iis accidere consuevit, qui in ipso negotio consilium capere coguntur. <sup>2</sup> At Cotta, qui cogitasset haec posse in itinere accidere, atque ob eam causam profectionis auctor non fuisset, nulla in re communi saluti deerat, et in appellandis cohortandisque  
35 militibus imperatoris, et in pugna militis officia praestabat. <sup>3</sup> Cum propter longitudinem agminis minus fa-

cile omnia per se obire et quid quoque loco faciendum esset providere possent, jusserunt pronuntiare ut impedimenta relinquerent atque in orbem consisterent. <sup>4</sup> Quod consilium, etsi in ejusmodi casu reprehendendum non est, tamen incommode accidit: nam et nostris militibus spem minuit, et hostes ad pugnam alacriores effecit, quod non sine summo timore et desperatione id factum videbatur. <sup>5</sup> Praeterea accidit, quod fieri necesse erat, ut vulgo milites ab signis discederent, quae quisque eorum carissima haberet ab impedimentis petere <sup>10</sup> atque abripere properaret; clamore et fletu omnia complerentur.

34. At barbaris consilium non defuit. Nam duces eorum tota acie pronuntiare jusserunt, ne quis ab loco discederet; illorum esse praedam, atque illis reservari <sup>15</sup> quaecumque Romani reliquissent; proinde omnia in victoria posita existimarent. <sup>2</sup> Erant et virtute et numero pugnando pares nostri; tametsi ab duce et a fortuna deserebantur, tamen omnem spem salutis in virtute ponebant; et quotiens quaeque cohors procurrerat, ab <sup>20</sup> ea parte magnus numerus hostium cadebat. <sup>3</sup> Qua re animadversa, Ambiorix pronuntiare jubet, ut procul tela coniciant neu propius accedant, et quam in partem Romani impetum fecerint cedant; levitate armorum et cotidiana exercitatione nihil iis noceri posse: <sup>25</sup> rursus se ad signa recipientes insequantur.

35. Quo praecepto ab iis diligentissime observato, cum quaequam cohors ex orbe excesserat atque impetum fecerat, hostes velocissime refugiebant. Interim eam partem nudari necesse erat, et ab latere aperto tela <sup>30</sup> recipi. <sup>2</sup> Rursus, cum in eum locum unde erant egressi reverti coeperant, et ab iis qui cesserant et ab iis qui proximi steterant circumveniebantur; sin autem locum tenere vellent, nec virtuti locus relinquebatur neque ab tanta multitudine conjecta tela conferti vitare poterant. <sup>35</sup> <sup>3</sup> Tamen tot incommodis conflictati, multis vulneribus

acceptis, resistebant ; et, magna parte diei consumpta, cum a prima luce ad horam octavam pugnaretur, nihil quod ipsis esset indignum committebant. <sup>4</sup> Tum T. Balventio, qui superiore anno primum pilum duxerat, 5 viro forti et magnae auctoritatis, utrumque femur tragula traicitur ; Q. Lucanius, ejusdem ordinis, fortissime pugnans, dum circumvento filio subvenit, interficitur ; L. Cotta legatus, omnes cohortes ordinesque adhortans, in adversum os funda vulneratur.

10 36. His rebus permotus Q. Titurius, cum procul Ambiorigem suos cohortantem conspexisset, interpretem suum Cn. Pompeium ad eum mittit, rogatum ut sibi militibusque parcat. <sup>2</sup> Ille appellatus respondit : ‘ Si velit secum colloqui, licere ; sperare a multitudine im- 15 petrari posse, quod ad militum salutem pertineat ; ipsi vero nihil nocitum iri, inque eam rem se suam fidem interponere.’ <sup>3</sup> Ille cum Cotta saucio communicat, si videatur, pugna ut excedant et cum Ambiorige una colloquantur : sperare, ab eo de sua ac militum salute 20 impetrare posse. Cotta se ad armatum hostem iturum negat, atque in eo perseverat.

37. Sabinus, quos in praesentia tribunos militum circum se habebat, et primorum ordinum centuriones, se sequi jubet ; et, cum propius Ambiorigem accessisset, 25 jussus arma abicere, imperatum facit, suisque ut idem faciant imperat. <sup>2</sup> Interim, dum de condicionibus inter se agunt, longiorque consulto ab Ambiorige instituitur sermo, paulatim circumventus interficitur. <sup>3</sup> Tum vero suo more victoriam conclamant, atque ululatum tollunt ; 30 impetuque in nostros facto ordines perturbant. Ibi L. Cotta pugnans interficitur cum maxima parte militum. <sup>4</sup> Reliqui se in castra recipiunt unde erant egressi : ex quibus L. Petrosidius aquilifer, cum magna multitudine hostium premeretur, aquilam intra vallum projecit, ipse 35 pro castris fortissime pugnans occiditur. <sup>5</sup> Illi aegre ad noctem oppugnationem sustinent : noctu ad unum



omnes, desperata salute, se ipsi interficiunt. Pauci, ex proelio lapsi, incertis itineribus per silvas ad T. Labienum legatum in hiberna perveniunt, atque eum de rebus gestis certiore faciunt.

38. Hac victoria sublatus Ambiorix statim cum equitatu in Aduatucos, qui erant ejus regno finitimi, proficiscitur; neque noctem neque diem intermittit, peditatumque subsequi jubet. <sup>2</sup> Re demonstrata, Aduatucisque concitatis, postero die in Nervios pervenit, hortaturque ne sui in perpetuum liberandi, atque ulciscendi Romanos pro iis quas acceperint injuriis, occasionem dimittant; <sup>3</sup> interfectos esse legatos duo, magnamque partem exercitus interisse demonstrat; nihil esse negotii subito oppressam legionem quae cum Cicerone hiemet interfici; se ad eam rem proficetur adiutorem. Facile hac oratione Nervii persuadet.

39. Itaque confestim dimissis nuntiis ad Ceutrones, Grudios, Levacos, Pleumoxios, Geidunnos, qui omnes sub eorum imperio sunt, quam maximas manus possunt cogunt, et de improvise ad Ciceronis hiberna advolant, nondum ad eum fama de Titurii morte perlata. <sup>2</sup> Huic quoque accidit, quod fuit necesse, ut nonnulli milites, qui lignationis munitioisque causa in silvas discessissent, repentino equitum adventu interciperentur. <sup>3</sup> His circumventis, magna manu Eburones, Nervii, Aduatuci, atque horum omnium socii et clientes legionem oppugnare incipiunt. Nostri celeriter ad arma concurrunt, vallum conscendunt. <sup>4</sup> Aegre is dies sustentatur, quod omnem spem hostes in celeritate ponebant, atque, hanc adepti victoriam, in perpetuum se fore victores confidebant.

40. Mittuntur ad Caesarem confestim ab Cicerone litterae, magnis propositis praemiis si pertulissent: obsessis omnibus viis, missi intercipiuntur. <sup>2</sup> Noctu ex ea materia quam munitio causa comportaverant, turres admodum cxx excitantur incredibili celeritate; quae

deesse operi videbantur perficiuntur. <sup>3</sup> Hostes postero die, multo majoribus coactis copiis, castra oppugnant, fossam complent. Eadem ratione qua pridie ab nostris resistitur: hoc idem deinceps reliquis fit diebus. <sup>4</sup> Nulla  
 5 pars nocturni temporis ad laborem intermittitur: non aegris, non vulneratis, facultas quietis datur. <sup>5</sup> Quaecumque ad proximi diei oppugnationem opus sunt, noctu comparantur: multae praeustae sudes, magnus muralium pilorum numerus instituitur; turres contabulantur;  
 10 pinnae loricaeque ex cratibus attexuntur. <sup>4</sup> Ipse Cicero, cum tenuissima valetudine esset, ne nocturnum quidem sibi tempus ad quietem relinquebat, ut ultro militum concursu ac vocibus sibi parcere cogeretur.

41. Tunc duces principesque Nerviorum, qui aliquem  
 15 sermonis aditum causamque amicitiae cum Cicerone habebant, colloqui sese velle dicunt. <sup>2</sup> Facta potestate, eadem quae Ambiorix cum Titurio egerat commemorant: omnem esse in armis Galliam, Germanos Rhenum transisse, Caesaris reliquorumque hiberna oppugnari.  
 20 <sup>3</sup> Addunt etiam de Sabini morte; Ambiorigem ostentant fidei faciendae causa. Errare eos dicunt, si quicquam ab his praesidii sperent qui suis rebus diffidant; sese tamen hoc esse in Ciceronem populumque Romanum animo, ut nihil nisi hiberna recusent, atque hanc  
 25 inveterascere consuetudinem nolint; licere illis incolumibus per se ex hibernis discedere, et quascumque in partes velint sine metu proficisci. <sup>4</sup> Cicero ad haec unum modo respondit: 'Non esse consuetudinem populi Romani, accipere ab hoste armato condicionem; si ab  
 30 armis discedere velint, se adiutore utantur legatosque ad Caesarem mittant; sperare, pro ejus justitia, quae petierint impetraturos.'

42. Ab hac spe repulsi Nervii vallo pedum novem et fossa pedum quindecim hiberna cingunt. <sup>2</sup> Haec et  
 35 superiorum annorum consuetudine ab nobis cognoverant, et quosdam de exercitu habebant captivos, ab his

docebantur: sed nulla ferramentorum copia quae esset ad hunc usum idonea, gladiis cespitem circumcidere, manibus sagulisque terram exhaurire nitebantur. <sup>3</sup> Quae quidem ex re hominum multitudo cognosci potuit: nam minus horis tribus milium passuum xv in circuitu munitionem perfecerunt; reliquisque diebus tures ad altitudinem valli, falces testudinesque, quas iidem captivi docuerant, parare ac facere coeperunt.

43. Septimo oppugnationis die, maximo coërto vento, ferventes fusili ex argilla glandes fundis et fervefacta jacula in casas, quae more Gallico stramentis erant tectae, jacere coeperunt. <sup>2</sup> Hae celeriter ignem comprehenderunt, et venti magnitudine in omnem locum castrorum distulerunt. Hostes maximo clamore, sic uti parta jam atque explorata victoria, tures testudinesque agere et scalis vallum ascendere coeperunt. <sup>3</sup> At tanta militum virtus atque ea praesentia animi fuit ut, cum undique flamma torrerentur, maximaque telorum multitudine premerentur, suaque omnia impedimenta atque omnes fortunas conflagrare intellegent, non modo demigrandi causa de vallo decederet nemo, sed paene ne respiceret quidem quisquam; ac tum omnes acerrime fortissimeque pugnarent. <sup>4</sup> Hic dies nostris longe gravissimus fuit; sed tamen hunc habuit eventum, ut eo die maximus numerus hostium vulneraretur atque interficeretur, ut se sub ipso vallo constipaverant recessumque primis ultimi non dabant. <sup>5</sup> Paulum quidem intermissa flamma, et quodam loco turri adacta et contingente vallum, tertiae cohortis centuriones ex eo quo stabant loco recesserunt, suosque omnes removerunt; nutu vocibusque hostes si introire vellent vocare coeperunt, quorum progredi ausus est nemo. Tum ex omni parte lapidibus coniectis deturbati, turrisque succisa est.

44. Erant in ea legione fortissimi viri centuriones, qui primis ordinibus appropinquarent, T. Pulio et L.

Vorenus. Hi perpetuas inter se controversias habebant quinam anteferretur, omnibusque annis de locis summis simultatibus contendebant. <sup>2</sup> Ex his Pulio, cum acerrime ad munitiones pugnaretur, "Quid dubitas," inquit, <sup>5</sup> "Vorene? aut quem locum tuae probandae virtutis expectas? hic dies de nostris controversiis judicabit." <sup>3</sup> Haec cum dixisset, procedit extra munitiones, quaque pars hostium confertissima est visa, irrumpit. Ne Vorenus quidem tum sese vallo continet, sed omnium <sup>10</sup> veritus existimationem subsequitur. <sup>4</sup> Mediocri spatio relicto, Pulio pilum in hostes immittit, atque unum ex multitudine procurrentem traicit; quo percusso et exanimato, hunc scutis protegunt, in hostem tela universi coniciunt, neque dant regrediendi facultatem. <sup>15</sup> <sup>5</sup> Transfigitur scutum Pulioni, et verutum in balteo defigitur. Avertit hic casus vaginam, et gladium educere conanti dextram moratur manum, impeditumque hostes circumsistunt. <sup>6</sup> Succurrit inimicus illi Vorenus et laboranti subvenit. Ad hunc se confestim a Pulione <sup>20</sup> omnis multitudo convertit; illum veruto arbitrantur occisum. <sup>7</sup> Gladio cominus rem gerit Vorenus, atque uno interfecto reliquos paulum propellit; dum cupidius instat, in locum dejectus inferiorem concidit. <sup>8</sup> Huic rursus circumvento fert subsidium Pulio, atque ambo <sup>25</sup> incolumes, compluribus interfectis, summa cum laude sese intra munitiones recipiunt. <sup>9</sup> Sic fortuna in contentione et certamine utrumque versavit, ut alter alteri inimicus auxilio salutique esset, neque dijudicari posset uter utri virtute anteferendus videretur.

<sup>30</sup> 45. Quanto erat in dies gravior atque asperior oppugnatio, et maxime quod, magna parte militum confecta vulneribus, res ad paucitatem defensorum pervenerat, tanto crebriores litterae nuntiique ad Caesarem mittebantur; quorum pars deprehensa in conspectu nostrorum <sup>35</sup> militum cum cruciatu necabatur. <sup>2</sup> Erat unus intus Nervius, nomine Vertico, loco natus honesto, qui a

prima obsidione ad Ciceronem per fugerat, suamque ei fidem praestiterat. <sup>3</sup>Hic servo spe libertatis magnisque persuadet praemiis, ut litteras ad Caesarem deferat. Has ille in jaculo illigatas effert; et Gallus inter Gallos sine ulla suspicione versatus ad Caesarem pervenit. 5 Ab eo de periculis Ciceronis legionisque cognoscitur.

46. Caesar, acceptis litteris hora circiter XI diei, statim nuntium in Bellovacos ad M. Crassum quaestorem mittit, cujus hiberna aberant ab eo milia passuum XXV; <sup>4</sup>jubet media nocte legionem proficisci, celeriterque ad se venire. <sup>2</sup>Exit cum nuntio Crassus. Alterum ad C. Fabium legatum mittit, ut in Atrebatium fines legionem adducat, qua sibi iter faciendum sciebat. <sup>3</sup>Scribit Labieno si reipublicae commodo facere posset, cum legione ad fines Nerviorum veniat: reliquam partem exercitus, 15 quod paulo aberat longius, non putat exspectandam: equites circiter quadringentos ex proximis hibernis colligit.

47. Hora circiter tertia ab antecursoribus de Crassi adventu certior factus, eo die milia passuum viginti pro- 20 cedit. <sup>2</sup>Crassum Samarobriuae praeficit legionemque attribuit, quod ibi impedimenta exercitus, obsides civitatum, litteras publicas, frumentumque omne quod eo tolerandae hiemis causa devexerat, relinquebat. <sup>3</sup>Fabius, ut imperatum erat, non ita multum moratus, in 25 itinere cum legione occurrit. <sup>4</sup>Labienus, interitu Sabini et caede cohortium cognita, cum omnes ad eum Treverorum copiae venissent, veritus, si ex hibernis fugae similem profectionem fecisset, ut hostium impetum sustinere posset, praesertim quos recenti victoria 30 efferi sciret, <sup>5</sup>litteras Caesari remittit, quanto cum periculo legionem ex hibernis educturus esset; rem gestam in Eburonibus perscribit; docet omnes equitatus peditatusque copias Treverorum tria milia passuum longe ab suis castris consedissee. 35

48. Caesar, consilio ejus probato, etsi opinione trium

1 legionum dejectus ad duas redierat, tamen unum com-  
 munis salutis auxilium in celeritate ponebat. 2 Venit  
 magnis itineribus in Nerviorum fines. Ibi ex captivis  
 cognoscit quae apud Ciceronem gerantur, quantoque in  
 5 periculo res sit. 3 Tum cuidam ex equitibus Gallis  
 magnis praemiis persuadet uti ad Ciceronem epistolam  
 deferat. 4 Hanc Graecis conscriptam litteris mittit, ne  
 intercepta epistola nostra ab hostibus consilia cognos-  
 cantur. 5 Si adire non possit, monet ut tragulam cum  
 10 epistola ad amentum deligata intra munitionem castro-  
 rum abiciat. In litteris scribit se cum legionibus pro-  
 fectum celeriter adfore; hortatur ut pristinam virtutem  
 retineat. 6 Gallus periculum veritus, ut erat praeceptum,  
 tragulam mittit. Haec casu ad turrim adhaesit, neque  
 15 ab nostris biduo animadversa, tertio die a quodam milite  
 conspicitur; dempta ad Ciceronem defertur. 7 Ille per-  
 lectam in conventu militum recitat, maximaque omnes  
 laetitia afficit. Tum fumi incendiorum procul videban-  
 tur, quae res omnem dubitationem adventus legionum  
 20 expulit.

49. Galli, re cognita per exploratores, obsidionem re-  
 linquunt; ad Caesarem omnibus copiis contendunt:  
 haec erant armata circiter milia sexaginta.<sup>2</sup> Cicero,  
 data facultate, Gallum ab eodem Verticone quem supra  
 25 demonstravimus repetit, qui litteras ad Caesarem refe-  
 rat; hunc admonet iter caute diligenterque faciat; per-  
 scribit in litteris hostes ab se discessisse, omnemque ad  
 eum multitudinem convertisse. 3 Quibus litteris circi-  
 ter media nocte Caesar allatis, suos facit certiores, eos-  
 30 que ad dimicandum animo confirmat. 4 Postero die luce  
 prima movet castra, et circiter milia passuum quattuor  
 progressus, trans vallem et rivum multitudinem hostium  
 conspicatur. 5 Erat magni periculi res tantulis copiis  
 iniquo loco dimicare: tum, quoniam obsidione libera-  
 35 tum Ciceronem sciebat, aequo animo remittendum de  
 celeritate existimabat. 6 Consedit, et quam aequissimo

loco potest castra communit. Atque haec, etsi erant  
 exigua per se, vix hominum milium septem, praeser-  
 tim nullis cum impedimentis, tamen angustiis viarum  
 quam maxime potest contrahit, eo consilio ut in sum- 5  
 mam contemptionem hostibus veniat. <sup>1</sup> Interim, specu-  
 latoribus in omnes partes dimissis, explorat quo commo-  
 dissime itinere valles transiri possit.

50. Eo die, parvulis equestribus proeliis ad aquam  
 factis, utrique sese suo loco continent: Galli, quod  
 ampliores copias quae nondum convenerant expecta- 10  
 bant; Caesar, si forte timoris simulatione hostes in suum  
 locum elicere posset, ut citra vallem pro castris proelio  
 contenderet; si id efficere non posset, ut, exploratis  
 itineribus, minore cum periculo vallem rivumque transi-  
 ret. <sup>2</sup> Prima luce hostium equitatus ad castra accedit, 15  
 proeliumque cum nostris equitibus committit. Caesar  
 consulto equites cedere seque in castra recipere jubet;  
 simul ex omnibus partibus castra altiore vallo muniri,  
 portasque obstrui, atque in his administrandis rebus  
 quam maxime concursari et cum simulatione agi ti- 20  
 moris jubet.

51. Quibus omnibus rebus hostes invitati, copias tra-  
 ducunt, aciemque iniquo loco constituunt; nostris vero  
 etiam de vallo deductis propius accedunt, et tela intra  
 munitionem ex omnibus partibus coniciunt, praeconi- 25  
 busque circummissis pronuntiari jubent, seu quis Gallus  
 seu Romanus velit ante horam tertiam ad se transire,  
 sine periculo licere; post id tempus non fore potesta-  
 tem. <sup>2</sup> Ac sic nostros contempserunt, ut, obstructis in  
 speciem portis singulis ordinibus cespitum, quod ea non 30  
 posse introrumpere videbantur, alii vallum manu scin-  
 dere, alii fossas complere inciperent. <sup>3</sup> Tum Caesar,  
 omnibus portis eruptione facta equitatuque emisso, ce-  
 leriter hostes in fugam dat, sic uti omnino pugnandi  
 causa resisteret nemo; magnumque ex iis numerum 35  
 occidit, atque omnes armis exuit.

52. Longius prosequi veritus, quod silvae paludesque intercedebant, neque etiam parvulo detrimento illorum locum relinqui videbat, omnibus suis incolumibus copiis, eodem die ad Ciceronem pervenit. <sup>2</sup>Institutas turres, 5 testudines, munitionesque hostium admiratur: legione producta, cognoscit non decimum quemque esse reliquum militem sine vulnere. <sup>3</sup>Ex his omnibus judicat rebus, quanto cum periculo et quanta cum virtute res sint administratae: Ciceronem pro ejus merito legionemque 10 collaudat; centuriones singillatim tribunosque militum appellat, quorum egregiam fuisse virtutem testimonio Ciceronis cognoverat. <sup>4</sup>De casu Sabini et Cottae certius ex captivis cognoscit. Postero die contione habita, rem gestam proponit, milites consolatur et confirmat: 15 quod detrimentum culpa et temeritate legati sit acceptum, hoc aequiore animo ferendum docet, quod, beneficio deorum immortalium et virtute eorum expiato incommodo, neque hostibus diutina laetatio neque ipsis longior dolor relinquatur.

<sup>20</sup> 53. Interim ad Labienum per Remos incredibili celeritate de victoria Caesaris fama perfertur; ut cum ab hibernis Ciceronis milia passuum abesset circiter sexaginta, eoque post horam nonam diei Caesar pervenisset, ante mediam noctem ad portas castrorum clamor oreretur, 25 quo clamore significatio victoriae gratulatioque ab Remis Labieno fieret. <sup>2</sup>Hac fama ad Treveros perlata, Indutiomarus, qui postero die castra Labieni oppugnare decreverat, noctu profugit copiasque omnes in Treveros reducit. <sup>3</sup>Caesar Fabium cum sua legione remittit in 30 hiberna, ipse cum tribus legionibus circum Samarobriam trinis hibernis hiemare constituit; et, quod tanti motus Galliae exstiterant, totam hiemem ipse ad exercitum manere decrevit. <sup>4</sup>Nam, illo incommodo de Sabini morte perlato, omnes fere Galliae civitates de bello consultabant; nuntios legationesque in omnes partes dimittebant; et quid reliqui consilii caperent atque unde 35



initium belli fieret explorabant, nocturnaue in locis desertis concilia habebant. <sup>5</sup> Neque ullum fere totius hiemis tempus sine sollicitudine Caesaris intercessit, quin aliquem de consiliis ac motu Gallorum nuntium acciperet. <sup>6</sup> In his ab L. Roscio [quaestore], quem le- 5 gioni tertiaedecimae praefecerat, certior factus est, magnas Gallorum copias earum civitatum quae Armoricae appellantur oppugnandi sui causa convenisse, neque longius milia passuum octo ab hibernis suis abfuisse, sed, nuntio allato de victoria Caesaris, discessisse adeo 10 ut fugae similis discessus videretur.

54. At Caesar, principibus cujusque civitatis ad se evocatis, alias territando cum se scire quae fierent denuntiaret, alias cohortando, magnam partem Galliae in officio tenuit. <sup>2</sup> Tamen Senones, quae est civitas im- 15 primis firma et magnae inter Gallos auctoritatis, Cavarinum, quem Caesar apud eos regem constituerat (cujus frater Moritasgus adventu in Galliam Caesaris, cujusque majores regnum obtinuerant), interficere publico consilio conati, cum ille praesensisset ac profugisset, usque 20 ad fines insecuti regno domoque expulerunt; <sup>3</sup> et, missis ad Caesarem satisfaciendi causa legatis, cum is omnem ad se senatum venire jussisset, dicto audientes non fuerunt. <sup>4</sup> Tantum apud homines barbaros valuit esse aliquos repertos principes inferendi belli, tantamque om- 25 nibus voluntatum commutationem attulit, ut — praeter Haeduos et Remos, quos praecipuo semper honore Caesar habuit, alteros pro vetere ac perpetua erga populum Romanum fide, alteros pro recentibus Gallici belli officiis — nulla fere civitas fuerit non suspecta nobis. <sup>5</sup> Idque 30 adeo haud scio mirandumne sit, cum compluribus aliis de causis, tum maxime quod ei qui virtute belli omnibus gentibus praeferebantur, tantum se ejus opinionis deperdidisse ut a populo Romano imperia perferrent, gravissime dolebant.

55. Treveri vero atque Indutiomarus totius hiemis

nullum tempus intermiserunt, quin trans Rhenum legatos mitterent, civitates sollicitarent, pecunias pollicerentur, magna parte exercitus nostri interfecta, multo minorem superesse dicerent partem. <sup>2</sup> Neque tamen  
 5 ulli civitati Germanorum persuaderi potuit ut Rhenum transiret, cum se bis expertos dicerent, Ariovisti bello, et Tencterorum transitu : non esse amplius fortunam temptaturos. <sup>3</sup> Hac spe lapsus Indutiomarus, nihilo minus copias cogere, exercere, a finitimis equos parare, exsules  
 10 damnatosque tota Gallia magnis praemiis ad se allicere coepit. Ac tantam sibi jam his rebus in Gallia auctoritatem comparaverat, ut undique ad eum legationes concurrerent, gratiam atque amicitiam publice privatimque peterent.

15 56. Ubi intellexit ultro ad se veniri, altera ex parte Senones Carnutesque conscientia facinoris instigari, altera Nervios Aduatucosque bellum Romanis parare, neque sibi voluntariorum copias defore si ex finibus suis progredi coepisset, armatum concilium indicit. <sup>2</sup> Hoc  
 20 more Gallorum est initium belli, quo lege communi omnes puberes armati convenire consuerunt ; qui ex iis novissimus venit, in conspectu multitudinis omnibus cruciatibus affectus necatur. <sup>3</sup> In eo concilio Cingetorigem, alterius principem factionis, generum suum,  
 25 quem supra demonstravimus Caesaris secutum fidem ab eo non discessisse, hostem judicat bonaque ejus publicat. <sup>4</sup> His rebus confectis, in concilio pronuntiat, arcessitum se a Senonibus et Carnutibus aliisque compluribus Galliae civitatibus ; huc iturum per fines Remorum, eorumque  
 30 que agros populaturum ; ac prius quam id faciat, castra Labieni oppugnaturum : quae fieri velit praecipit.

57. Labienus, cum et loci natura et manu munitissimis castris sese teneret, de suo ac legionis periculo nihil timebat ; ne quam occasionem rei bene gerendae dimitteret cogitabat. <sup>2</sup> Itaque, a Cingetorige atque ejus propinquis oratione Indutiomari cognita, quam in concilio

habuerat, nuntios mittit ad finitimas civitates, equitesque undique evocat: his certum diem conveniendi dicit.

<sup>3</sup> Interim prope cotidie cum omni equitatu Indutiomarus sub castris ejus vagabatur, alias ut situm castrorum cognosceret, alias colloquendi aut territandi causa: <sup>5</sup> equites plerumque omnes tela intra vallum coniciebant.

<sup>4</sup> Labienus suos intra munitionem continebat, timorisque opinionem quibuscumque poterat rebus augebat.

58. Cum majore in dies contempione Indutiomarus ad castra accederet, nocte una, intromissis equitibus <sup>10</sup> omnium finitimarum civitatum, quos arcessendos curaverat, tanta diligentia omnes suos custodiis intra castra continuit, ut nulla ratione ea res enuntiari aut ad Treveros perferri posset. <sup>2</sup> Interim ex consuetudine cotidiana Indutiomarus ad castra accedit, atque ibi magnam <sup>15</sup> partem diei consumit; equites tela coniciunt, et magna cum contumelia verborum nostros ad pugnam evocant. Nullo ab nostris dato responso, ubi visum est sub vesperum dispersi ac dissipati discedunt. <sup>3</sup> Subito Labienus duabus portis omnem equitatum emittit; praecipit atque <sup>20</sup> interdicat, proterritis hostibus atque in fugam coniectis (quod fore sicut accidit videbat), unum omnes peterent Indutiomarus; neu quis quem prius vulneret, quam illum interfectum viderit, quod mora reliquorum spatium nactum illum effugere nolebat: magna proponit iis qui <sup>25</sup> occiderint praemia; submittit cohortes equitibus subsidio. <sup>4</sup> Comprobat hominis consilium fortuna; et cum unum omnes peterent, in ipso fluminis vado deprehensus Indutiomarus interficitur, caputque ejus refertur in castra: redeuntes equites quos possunt consecantur atque <sup>30</sup> occidunt. Hac re cognita, omnes Eburonum et Nerviorum quae convenerant copiae discedunt; pauloque habuit post id factum Caesar quietiorem Galliam.

## BOOK VI.

SECOND EXPEDITION INTO GERMANY. — Disturbances continue, and are evidently kept up by understanding with the Germans. Cæsar accordingly, having disarmed the Nervii, the Treveri also being defeated by Labienus, decides again to cross the Rhine (1-10). Here follows a long and interesting description of the people and customs of Gaul (11-20); and a very curious account of the Germans, with descriptions, half fabulous, of the Hercynian Wood and the wild beasts there inhabiting, the reindeer, elk, and buffalo (21-28). Finding the country mostly a wilderness, Cæsar returns to Gaul, where the force of Ambiorix is crushed, and the territory of the Eburones ravaged (29-34). A dangerous attack by the Sigambri, a German tribe from over the Rhine, is repelled by Cæsar's advance (35-42). After inflicting military severities upon the resisting tribes, he returns to Italy, leaving the Province, as he thinks, fully subdued (43, 44).

MULTIS de causis Caesar majorem Galliae motum expectans, per M. Silanum C. Antistium Reginum T. Sextium legatos delectum habere instituit: <sup>2</sup> simul ab Cn. Pompeio proconsule petit, quoniam ipse ad urbem cum imperio reipublicae causa remaneret, quos ex Cisalpina Gallia consulis sacramento rogavisset, ad signa convenire et ad se proficisci juberet; <sup>3</sup> magni interesse etiam in reliquum tempus ad opinionem Galliae existimans, tantas videri Italiae facultates, ut, si quid esset in bello detrimenti acceptum, non modo id brevi tempore resarciri, sed etiam majoribus adaugeri copiis posset. <sup>4</sup> Quod cum Pompeius et reipublicae et amicitiae tribuisset, celeriter confecto per suos dilectu, tribus ante exactam hiemem et constitutis et adductis legionibus, duplicatoque earum cohortium numero quas cum Q. Titurio amiserat, et celeritate et copiis docuit quid populi Romani disciplina atque opes possent.

2. Interfecto Indutiomaro, ut docuimus, ad ejus propinquos a Treveris imperium defertur. Illi finitimos Germanos sollicitare et pecuniam polliceri non desistunt. <sup>2</sup>Cum ab proximis impetrare non possent, ultteriores temptant. Inventis nonnullis civitatibus, jurejurando 5 inter se confirmant, obsidibusque de pecunia cavent: Amborigem sibi societate et foedere adjungunt. <sup>3</sup>Quibus rebus cognitis, Caesar, cum undique bellum parari videret, Nervios, Aduatucos ac Menapios, adjunctis Cisirhenanis omnibus Germanis, esse in armis, Senones 10 ad imperatum non venire et cum Carnutibus finitimisque civitatibus consilia communicare, a Treveris Germanos crebris legationibus sollicitari, maturius sibi de bello cogitandum putavit.

3. Itaque, nondum hieme confecta, proximis quattuor 15 coactis legionibus, de improvise in fines Nerviorum contendit, et prius quam illi aut convenire aut profugere possent, magno pecoris atque hominum numero capto atque ea praeda militibus concessa, vastatisque agris, in deditionem venire atque obsides sibi dare coëgit. 20 <sup>2</sup>Eo celeriter confecto negotio, rursus in hiberna legiones reduxit. Concilio Galliae primo vere, uti instituerat, indicto, cum reliqui praeter Senones, Carnutes, Treverosque, venissent, initium belli ac defectionis hoc esse arbitratus, ut omnia postponere videretur, concilium 25 Lutetiam Parisiorum transfert. <sup>3</sup>Confines erant hi Senonibus, civitatemque patrum memoria conjunxerant; sed ab hoc consilio abfuisse existimabantur. Hac re pro suggestu pronuntiata, eodem die cum legionibus in Senones proficiscitur, magnisque itineribus eo pervenit. 30

4. Cognito ejus adventu, Acco, qui princeps ejus consilii fuerat, jubet in oppida multitudinem convenire: conantibus, prius quam id effici posset, adesse Romanos nuntiatur. <sup>2</sup>Necessario sententia desistunt, legatosque deprecandi causa ad Caesarem mittunt; adeunt per 35 Haeduos, quorum antiquitas erat in fide civitas. <sup>3</sup>Liben-

ter Caesar, petentibus Haeduis, dat veniam excusationemque accipit, quod aestivum tempus instantis belli, non quaestionis, esse arbitrabatur; obsidibus imperatis centum, hos Haeduis custodiendos tradit. <sup>3</sup> Eodem Carnutes legatos obsidesque mittunt, usi deprecatoribus Remis, quorum erant in clientela: eadem ferunt responsa. Peragit concilium Caesar, equitesque imperat civitatibus.

5. Hac parte Galliae pacata, totus et mente et animo in bellum Treverorum et Ambiorigis insistit. Cavarium cum equitatu Senonum secum proficisci jubet, ne quis aut ex hujus iracundia, aut ex eo quod meruerat odio, civitatis motus existat. <sup>2</sup> His rebus constitutis, quod pro explorato habebat Ambiorigem proelio non esse concertaturum, reliqua ejus consilia animo circumspiciebat. <sup>3</sup> Erant Menapii propinqui Eburonum finibus, perpetuis paludibus silvisque muniti, qui uni ex Gallia de pace ad Caesarem legatos numquam miserant. Cum his esse hospitium Ambiorigi sciebat: item per Treveros venisse Germanis in amicitiam cognoverat. <sup>4</sup> Haec prius illi detrahenda auxilia existimabat quam ipsum bello lacesseret; ne, desperata salute, aut se in Menapios abderet aut cum Transrhenanis congredi cogeretur. <sup>5</sup> Hoc inito consilio, totius exercitus impedimenta ad Labienum in Treveros mittit, duasque legiones ad eum proficisci jubet; ipse cum legionibus expeditis quinque in Menapios proficiscitur. <sup>6</sup> Illi, nulla coacta manu, loci praesidio freti, in silvas paludesque confugiunt suaque eodem conferunt.

6. Caesar, partitis copiis cum C. Fabio legato et M. Crasso quaestore, celeriterque effectis pontibus, adit tripartito, aedificia vicosque incendit, magno pecoris atque hominum numero potitur. <sup>2</sup> Quibus rebus coacti Menapii legatos ad eum pacis petendae causa mittunt. Ille, obsidibus acceptis, hostium se habiturum numero confirmat, si aut Ambiorigem aut ejus legatos finibus suis

recepissent. <sup>3</sup> His confirmatis rebus, Commium Atrebatem cum equitatu custodis loco in Menapiis relinquit; ipse in Treveros proficiscitur.

7. Dum haec a Caesare geruntur, Treveri, magnis coactis peditatus equitatusque copiis, Labienum cum <sup>5</sup> una legione quae in eorum finibus hiemaverat adoriri parabant: jamque ab eo non longius bidui via aberant, cum duas venisse legiones missu Caesaris cognoscunt. <sup>2</sup> Positis castris a milibus passuum quindecim, auxilia Germanorum expectare constituunt. Labienus, hos- <sup>10</sup> tium cognito consilio, sperans temeritate eorum fore aliquam dimicandi facultatem, praesidio quinque cohortium impedimentis relicto, cum xxv cohortibus magnoque equitatu contra hostem proficiscitur; et, mille passuum intermisso spatio, castra communit. <sup>3</sup> Erat <sup>15</sup> inter Labienum atque hostem difficili transitu flumen ripisque praeuptis. Hoc neque ipse transire habebat in animo, neque hostes transituros existimabat. Augebatur auxiliorum cotidie spes. <sup>4</sup> Loquitur in concilio palam: 'Quoniam Germani appropinquare dicantur, sese <sup>20</sup> suas exercitusque fortunas in dubium non devocaturum, et postero die prima luce castra moturum.' <sup>5</sup> Celeriter haec ad hostes deferuntur, ut ex magno Gallorum equitum numero nonnullos Gallicis rebus favere natura coge- <sup>25</sup> bat. <sup>6</sup> Labienus, noctu tribunis militum primisque ordinibus convocatis, quid sui sit consilii proponit, et, quo facilius hostibus timoris det suspicionem, majore strepitu et tumultu quam populi Romani fert consuetudo castra moveri jubet. <sup>7</sup> His rebus fugae similem <sup>30</sup> profectionem efficit. Haec quoque per exploratores ante lucem in tanta propinquitate castrorum ad hostes deferuntur.

8. Vix agmen novissimum extra munitiones processerat, cum Galli — cohortati inter se ne speratam praedam ex manibus demitterent; longum esse, perterritis Ro- <sup>35</sup> manis, Germanorum auxilium expectare; neque suam

pati dignitatem, ut tantis copiis tam exiguam manum praesertim fugientem atque impeditam adoriri non audeant — flumen transire et iniquo loco committere proelium non dubitant. <sup>2</sup> Quae fore suspicatus Labienus, ut  
 5 omnes citra flumen eliceret, eadem usus simulatione itineris, placide progrediebatur. <sup>3</sup> Tum, praemissis paulum impedimentis atque in tumultu quodam collocatis, “Habetis,” inquit, “milites, quam petistis facultatem: hostem impedito atque iniquo loco tenetis: praestate  
 10 eandem nobis ducibus virtutem quam saepenumero imperatori praestitistis; atque adesse illum et haec coram cernere existimate.” <sup>4</sup> Simul signa ad hostem converti aciemque dirigi jubet; et, paucis turmis praesidio ad impedimenta dimissis, reliquos equites ad latera  
 15 disponit. Celeriter nostri, clamore sublato, pila in hostes immittunt. <sup>5</sup> Illi, ubi praeter spem quos fugere credebant infestis signis ad se ire viderunt, impetum modo ferre non potuerunt, ac primo concursu in fugam coniecti proximas silvas petierunt. <sup>6</sup> Quos Labienus  
 20 equitatu consecutus, magno numero interfecto, compluribus captis, paucis post diebus civitatem recepit. Nam Germani, qui auxilio veniebant, percepta Treverorum fuga, sese domum receperunt. <sup>7</sup> Cum his propinqui Indutiomari, qui defectionis auctores fuerant,  
 25 comitati eos ex civitate excesserunt. Cingetorigi, quem ab initio permansisse in officio demonstravimus, principatus atque imperium est traditum.

9. Caesar, postquam ex Menapiis in Treveros venit, duabus de causis Rhenum transire constituit: quarum  
 30 una erat quod auxilia contra se Treveris miserant; altera, ne ad eos Ambiorix receptum haberet. <sup>2</sup> His constitutis rebus, paulum supra eum locum quo ante exercitum traduxerat facere pontem instituit. Nota atque instituta ratione, magno militum studio, paucis  
 35 diebus opus efficitur. <sup>3</sup> Firmo in Treveris ad pontem praesidio relicto, ne quis ab his subito motus oreretur,



reliquas copias equitatumque traducit. <sup>4</sup> Ubi, qui ante obsides dederant atque in deditionem venerant, purgandi sui causa ad eum legatos mittunt, qui doceant, neque auxilia ex sua civitate in Treveros missa, neque ab se fidem laesam: <sup>5</sup> petunt atque orant ut sibi parcat; ne, communi odio Germanorum, innocentes pro nocentibus poenas pendant; si amplius obsidum vellet, dare pollicentur. <sup>6</sup> Cognita Cæsar causa, reperit ab Suevis auxilia missa esse; Ubiorum satisfactionem accipit; aditus viasque in Suevos perquirat. 10

10. Interim, paucis post diebus, fit ab Ubiis certior Suevos omnes in unum locum copias cogere, atque iis nationibus, quæ sub eorum sint imperio, denuntiari, ut auxilia peditatus equitatusque mittant. <sup>2</sup> His cognitis rebus, rem frumentariam providet, castris idoneum locum <sup>15</sup> deligit, Ubiis imperat ut pecora deducant, suaque omnia ex agris in oppida conferant, — sperans barbaros atque imperitos homines, inopia cibariorum adductos, ad iniquam pugnandi condicionem posse deduci; mandat ut crebros exploratores in Suevos mittant, quæque apud <sup>20</sup> eos gerantur cognoscant. <sup>3</sup> Illi imperata faciunt; et, paucis diebus intermissis, referunt: ‘Suevos omnes, posteaquam certiores nuntii de exercitu Romanorum venerint, cum omnibus suis sociorumque copiis quas coëgisissent, penitus ad extremos fines se recepisse; <sup>4</sup> silvam <sup>25</sup> esse ibi infinita magnitudine, quæ appellatur Bacenis; hanc longe introrsus pertinere, et pro nativo muro objectam, Cheruscos ab Suevis, Suevosque ab Cheruscis, iniuriis incursionibusque prohibere; ad ejus initium silvæ Suevos adventum Romanorum expectare constituisse.’ <sup>30</sup>

11. Quoniam ad hunc locum perventum est, non alienum esse videtur, de Galliae Germaniaeque moribus, et quo differant hae nationes inter sese, proponere.

<sup>2</sup> In Gallia non solum in omnibus civitatibus atque in omnibus pagis [partibusque], sed paene etiam in singulis <sup>35</sup> domibus, factiones sunt; earumque factionum principes

sunt, qui summam auctoritatem eorum iudicio habere existimantur, quorum ad arbitrium iudiciumque summa omnium rerum consiliorumque redeat. <sup>3</sup>Itaque ejus rei causa antiquitus institutum videtur, ne quis ex plebe  
5 contra potentiores auxilii egeret; suos enim quisque opprimi et circumveniri non patitur, neque, aliter si faciat, ullam inter suos habet auctoritatem. <sup>4</sup>Haec eadem ratio est in summa totius Galliae; namque omnes civitates in partes divisae sunt duas.

10 12. Cum Caesar in Galliam venit, alterius factionis principes erant Haedui, alterius Sequani. Hi, cum per se minus valerent (quod summa auctoritas antiquitus erat in Haeduis, magnaeque eorum erant clientelae), Germanos atque Ariovistum sibi adjunxerant, eosque ad  
15 se magnis jacturis pollicitationibusque perduxerant. <sup>2</sup>Proeliis vero compluribus factis secundis, atque omni nobilitate Haeduum interfecta, tantum potentia antecesserant, ut magnam partem clientium ab Haeduis ad se traducerent, obsidesque ab iis principum filios acciperent, et publice jurare cogerent nihil se contra Sequanos  
20 consilii inituros, et partem finitimi agri per vim occupatam possiderent, Galliaeque totius principatum obtinerent. <sup>3</sup>Qua necessitate adductus, Divitiacus, auxilii petendi causa Romam ad Senatum profectus, infecta re  
25 redierat. <sup>4</sup>Adventu Caesaris facta commutatione rerum, obsidibus Haeduis redditis, veteribus clientelis restitutis, novis per Caesarem comparatis, quod hi, qui se ad eorum amicitiam aggregaverant, meliore condicione atque aequiore imperio se uti videbant, reliquis rebus  
30 eorum gratia dignitateque amplificata, Sequani principatum dimiserant. <sup>5</sup>In eorum locum Remi successerant: quos quod adaequare apud Caesarem gratia intellegebatur, ii qui propter veteres inimicitias nullo modo cum Haeduis conjungi poterant se Remis in clientelam dicabant. <sup>6</sup>Hos illi diligenter tuebantur: ita et  
35 novam et repente collectam auctoritatem tenebant.

Eo tum statu res erat, ut longe principes haberentur Haedui, secundum locum dignitatis Remi obtinerent.

13. In omni Gallia eorum hominum qui aliquo sunt numero atque honore genera sunt duo. Nam plebes paene servorum habetur loco, quae nihil audet per se, 5 et nullo adhibetur consilio. <sup>2</sup> Plerisque, cum aut aere alieno aut magnitudine tributorum aut injuria potentiorum premuntur, sese in servitatem dicant nobilibus. In hos eadem omnia sunt jura quae dominis in servos. <sup>3</sup> Sed de his duobus generibus alterum est Druidum, 10 alterum Equitum. Illi rebus divinis intersunt, sacrificia publica ac privata procurant, religiones interpretantur. <sup>4</sup> Ad eos magnus adulescentium numerus disciplinae causa concurrat, magnoque hi sunt apud eos honore. Nam fere de omnibus controversiis publicis 15 privatisque constituunt; et, si quod est admissum facinus, si caedes facta, si de hereditate, de finibus controversia est, iidem decernunt; praemia poenasque constituunt: si qui, aut privatus aut populus, eorum decreto non stetit, sacrificiis interdicunt. <sup>5</sup> Haec poena 20 apud eos est gravissima. Quibus ita est interdictum, hi numero impiorum ac sceleratorum habentur; his omnes decedunt, aditum sermonemque defugiunt, ne quid ex contagione incommodi accipiant: neque his petentibus jus redditur, neque honos ullus communicatur. 25 <sup>6</sup> His autem omnibus Druidibus praest unus, qui summam inter eos habet auctoritatem. Hoc mortuo, si qui ex reliquis excellit dignitate, succedit; aut, si sunt plures pares, suffragio Druidum, nonnunquam etiam armis de principatu contendunt. <sup>7</sup> Hi certo anni 30 tempore in finibus Carnutum, quae regio totius Galliae media habetur, considunt in loco consecrato: huc omnes undique qui controversias habent conveniunt, eorumque decretis judiciisque parent. <sup>8</sup> Disciplina in Britannia reperta atque inde in Galliam translata esse 35 existimatur; et nunc, qui diligentius eam rem cognos-

cere volunt, plerumque illo discendi causa proficiscuntur.

14. Druides a bello abesse consuerunt, neque tributa una cum reliquis pendunt ; militiae vacationem omnium-  
 5 que rerum habent immunitatem. <sup>2</sup> Tantis excitati præmiis, et sua sponte multi in disciplinam conveniunt, et a parentibus propinquisque mittuntur. Magnum ibi numerum versuum ediscere dicuntur. Itaque annos nonnulli vicens in disciplina permanent. <sup>3</sup> Neque fas  
 10 esse existimant ea litteris mandare, cum in reliquis fere rebus, publicis privatisque rationibus, Graecis litteris utantur. <sup>4</sup> Id mihi duabus de causis instituisse videntur : quod neque in vulgum disciplinam efferri velint, neque eos qui discunt, litteris confisos, minus memoriae  
 15 studere, — quod fere plerisque accidit, ut praesidio litterarum diligentiam in perdiscendo ac memoriam remittant. <sup>5</sup> In primis hoc volunt persuadere, non interire animas, sed ab aliis post mortem transire ad alios ; atque hoc maxime ad virtutem excitari putant, metu  
 20 mortis neglecto. <sup>6</sup> Multa praeterea de sideribus atque eorum motu, de mundi ac terrarum magnitudine, de rerum natura, de deorum immortalium vi ac potestate disputant et juventuti tradunt.

15. Alterum genus est Equitum. Hi, cum est usus  
 25 atque aliquod bellum incidit (quod fere ante Caesaris adventum quotannis accidere solebat, uti aut ipsi injurias inferrent aut illatas propulsarent), omnes in bello versantur ; <sup>2</sup> atque eorum ut quisque est genere copiisque amplissimus, ita plurimos circum se ambactos clientes-  
 30 que habet. Hanc unam gratiam potentiamque noverrunt.

16. Natio est omnis Gallorum admodum dedita religionibus ; atque ob eam causam, qui sunt affecti gravioribus morbis, quique in proeliis periculisque versantur,  
 35 aut pro victimis homines immolant, aut se immolatuos vovent, administrisque ad ea sacrificia Druidibus utun-

tur, — quod, pro vita hominis nisi hominis vita reddatur, non posse deorum immortalium numen placari arbitrantur; publiceque ejusdem generis habent instituta sacrificia. <sup>2</sup> Alii immani magnitudine simulacra habent, quorum contexta viminibus membra vivis hominibus <sup>5</sup> complent; quibus succensis, circumventi flamma exanimantur homines. <sup>3</sup> Supplicia eorum qui in furto aut in latrocinio aut aliqua noxa sint comprehensi, gratiora diis immortalibus esse arbitrantur; sed, cum ejus generis copia defecit, etiam ad innocentium supplicia de- <sup>10</sup> scendent.

17. Deum maxime Mercurium colunt: hujus sunt plurima simulacra; hunc omnium inventorem artium ferunt, hunc viarum atque itinerum ducem, hunc ad quaestus pecuniae mercaturasque habere vim maximam <sup>15</sup> arbitrantur. <sup>2</sup> Post hunc, Apollinem et Martem et Jovem et Minervam. De his eandem fere quam reliquae gentes habent opinionem: Apollinem morbos depellere; Minervam operum atque artificiorum initia tradere; Jovem imperium caelestium tenere; Martem bella regere. <sup>20</sup>

<sup>3</sup> Huic, cum proelio dimicare constituerunt, ea quae bello ceperint plerumque devovent: quom superaverunt, animalia capta immolant, reliquasque res in unum locum conferunt. <sup>4</sup> Multis in civitatibus harum rerum exstructos tumulos locis consecratis conspicari licet. <sup>5</sup> Neque <sup>25</sup> saepe accidit, ut neglecta quispiam religione, aut capta apud se occultare aut posita tollere auderet; gravissimumque ei rei supplicium cum cruciatu constitutum est.

18. Galli se omnes ab Dite patre prognatos praedicant, idque ab Druidibus proditum dicunt. Ob eam <sup>30</sup> causam spatia omnis temporis non numero dierum sed noctium finiunt; dies natales et mensium et annorum initia sic observant, ut noctem dies subsequatur. <sup>2</sup> In reliquis vitae institutis hoc fere ab reliquis differunt, quod suos liberos, nisi cum adoleverunt, ut munus mili- <sup>35</sup> tiae sustinere possint, palam ad se adire non patiuntur;

filiumque puerili aetate in publico in conspectu patris adsistere turpe ducunt.

19. Viri, quantas pecunias ab uxoribus dotis nomine acceperunt, tantas ex suis bonis, aestimatione facta, cum dotibus communicant. <sup>2</sup>Hujus omnis pecuniae conjunctim ratio habetur, fructusque servantur: uter eorum vita superarit, ad eum pars utriusque cum fructibus superiorum temporum pervenit. <sup>3</sup>Viri in uxores, sicut in liberos, vitae necisque habent potestatem; et cum paterfamiliae illustriore loco natus decessit, ejus propinqui conveniunt, et de morte, si res in suspicionem venit, de uxoribus in servilem modum quaestionem habent, et si compertum est, igni atque omnibus tormentis excruciatas interficiunt. <sup>4</sup>Funera sunt pro cultu Gallorum magna et sumptuosa; omniaque, quae vivis cordi fuisse arbitrantur, in ignem inferunt, etiam animalia: ac paulo supra hanc memoriam servi et clientes, quos ab iis dilectos esse constabat, justis funeribus confectis, una cremabantur.

20. Quae civitates commodius suam rem publicam administrare existimantur, habent legibus sanctum, si quis quid de republica a finitimis rumore aut fama acceperit, uti ad magistratum deferat, neve cum quo alio communicet: <sup>2</sup>quod saepe homines temerarios atque imperitos falsis rumoribus terreri, et ad facinus impelli, et de summis rebus consilium capere, cognitum est. <sup>3</sup>Magistratus quae visa sunt occultant; quaeque esse ex usu judicaverunt multitudini produnt. De republica nisi per concilium loqui non conceditur.

21. Germani multum ab hac consuetudine differunt. Nam neque Druides habent qui rebus divinis praesint, neque sacrificiis student. <sup>2</sup>Deorum numero eos solos ducunt, quos cernunt et quorum aperte opibus juvantur, Solem et Vulcanum et Lunam; reliquos ne fama quidem acceperunt. <sup>3</sup>Vita omnis in venationibus atque in studiis rei militaris consistit: ab parvulis labori ac du-

ritiae student. <sup>4</sup>Qui diutissime impuberes permanse-  
runt, maximam inter suos ferunt laudem : hoc ali statu-  
ram, ali vires nervosque confirmari, putant. <sup>5</sup>Intra  
annum vero vicesimum feminae notitiam habuisse, in  
turpissimis habent rebus : cujus rei nulla est occultatio, 5  
quod et promiscue in fluminibus perluuntur, et pellibus  
aut parvis rhenonum tegimentis utuntur, magna corpo-  
ris parte nuda.

22. Agriculturae non student ; majorque pars eorum  
victus in lacte, caseo, carne consistit. <sup>2</sup>Neque quis- 10  
quam agri modum certum aut fines habet proprios ; sed  
magistratus ac principes in annos singulos gentibus  
cognitionibusque hominum, qui una coierunt, quantum  
et quo loco visum est agri attribuunt, atque anno post  
alio transire cogunt. <sup>3</sup>Ejus rei multas afferunt causas : 15  
ne, assidua consuetudine capti, studium belli gerendi  
agricultura commutent ; ne latos fines parare studeant,  
potentioresque humiliores possessionibus expellant ; ne  
accuratius ad frigora atque aestus vitandos aedificent ;  
ne qua oriatur pecuniae cupiditas, qua ex re factiones 20  
dissensionesque nascuntur ; ut animi aequitate plebem  
contineant, cum suas quisque opes cum potentissimis  
aequari videat.

23. Civitatibus maxima laus est, quam latissime cir-  
cum se vastatis finibus solitudines habere. Hoc pro- 25  
prium virtutis existimant, expulsos agris finitimos  
cedere, neque quemquam prope audere consistere :  
simul hoc se fore tutiores arbitrantur, repentinae in-  
cursionis timore sublato. <sup>2</sup>Cum bellum civitas aut  
illatum defendit aut infert, magistratus qui ei bello 30  
praesint, ut vitae necisque habeant potestatem, deli-  
guntur. <sup>3</sup>In pace nullus est communis magistratus,  
sed principes regionum atque pagorum inter suos jus  
dicunt, controversiasque minuunt. <sup>4</sup>Latrocinia nullam  
habent infamiam quae extra fines cujusque civitatis 35  
fiunt, atque ea juventutis exercendae ac desidia minu-

endae causa fieri praedicant. <sup>5</sup> Atque ubi quis ex principibus in concilio dixit 'se ducem fore, qui sequi velint profiteantur,' — consurgunt ii qui et causam et hominem probant, suumque auxilium pollicentur, atque ab multitudine collaudantur; qui ex his secuti non sunt, in desertorum ac proditorum numero ducuntur, omniumque his rerum postea fides derogatur. <sup>6</sup> Hospitem violare fas non putant: qui quaque de causa ad eos venerunt, ab injuria prohibent sanctosque habent; hisque omnium domus patent, victusque communicatur.

24. Ac fuit antea tempus, cum Germanos Galli virtute superarent, ultro bella inferrent, propter hominum multitudinem agrique inopiam trans Rhenum colonias mitterent. <sup>2</sup> Itaque ea quae fertilissima Germaniae sunt loca, circum Hercyniam silvam (quam Eratostheni et quibusdam Graecis fama notam esse video, quam illi Orcyniam appellant), Volcae Tectosages occupaverunt atque ibi consederunt. <sup>3</sup> Quae gens ad hoc tempus his sedibus sese continet, summamque habet justitiae et bellicae laudis opinionem. <sup>4</sup> Nunc quidem in eadem inopia, egestate, patientiaque Germani permanent, eodem victu et cultu corporis utuntur; Gallis autem provinciarum propinquitas et transmarinarum rerum notitia multa ad copiam atque usum largitur. <sup>5</sup> Paulatim adsuefacti superari, multisque victi proeliis, ne se quidem ipsi cum illis virtute comparant.

25. Hujus Hercyniae silvae, quae supra demonstrata est, latitudo novem dierum iter expedito patet: non enim aliter finiri potest, neque mensuras itinerum noverrunt. <sup>2</sup> Oritur ab Helvetiorum et Nemetum et Rauracorum finibus, rectaque fluminis Danubii regione pertinet ad fines Dacorum et Anartium; hinc se flectit sinistrorsus diversis ab flumine regionibus, multarumque gentium fines propter magnitudinem attingit. <sup>3</sup> Neque quisquam est hujus Germaniae, qui se [aut audisse] aut adisse ad initium ejus silvae dicat, cum dierum iter



sexaginta processerit, aut quo ex loco oriatur acceperit. <sup>4</sup>Multaque in ea genera ferarum nasci constat, quae reliquis in locis visa non sint: ex quibus quae maxime differant ab ceteris et memoriae prodenda videantur, haec sunt.

26. Est bos, cervi figura, cujus a media fronte inter aures unum cornu existit, excelsius magisque directum his quae nobis nota sunt cornibus. <sup>2</sup>Ab ejus summo sicut palmae ramique late diffunduntur. Eadem est feminae marisque natura, eadem forma magnitudoque <sup>10</sup>cornuum.

27. Sunt item, quae appellantur Alces. Harum est consimilis capris figura et varietas pellium; sed magnitudine paulo antecedunt, mutilaeque sunt cornibus, et crura sine nodis articulisque habent; neque quietis <sup>15</sup>causa procumbunt, neque, si quo afflictas casu conciderunt, erigere sese aut sublevare possunt. <sup>2</sup>His sunt arbores pro cubilibus: ad eas se applicant, atque ita paulum modo reclinatae quietem capiunt. <sup>3</sup>Quarum ex <sup>20</sup>vestigiiis cum est animadversum a venatoribus quo se recipere consuerint, omnes eo loco aut ab radicibus subruunt, aut accidunt arbores, tantum ut summa species earum stantium relinquatur. <sup>4</sup>Huc cum se consuetudine reclinaverunt, infirmas arbores pondere affligunt atque una ipsae concidunt. <sup>25</sup>

28. Tertium est genus eorum qui Uri appellantur. Hi sunt magnitudine paulo infra elephantos; specie et colore et figura tauri. <sup>2</sup>Magna vis eorum est et magna velocitas; neque homini neque ferae quam conspexerunt parcunt. Hos studiose foveis captos interficiunt. <sup>30</sup><sup>3</sup>Hoc se labore durant adulescentes, atque hoc genere venationis exercent; et qui plurimos ex his interfecerunt, relatis in publicum cornibus, quae sint testimonio, magnam ferunt laudem. <sup>4</sup>Sed adsuescere ad homines et mansuefieri ne parvuli quidem excepti possunt. <sup>35</sup><sup>5</sup>Amplitudo cornuum et figura et species multum a

nostrorum boum cornibus differt. Haec studiose conquisita ab labris argento circumcludunt, atque in amplissimis epulis pro poculis utuntur.

29. Caesar, postquam per Ubios exploratores compe-  
 5 rit Suevos sese in silvas recepisse, inopiam frumenti  
 veritus (quod, ut supra demonstravimus, minime omnes  
 Germani agriculturae student), constituit non progredi  
 longius; <sup>2</sup> sed, ne omnino metum reditus sui barbaris  
 tolleret, atque ut eorum auxilia tardaret, reducto exer-  
 10 citu, partem ultimam pontis, quae ripas Ubiorum con-  
 tingebat, in longitudinem pedum ducentorum rescindit,  
 atque in extremo ponte turrim tabulatorum quattuor  
 constituit, praesidiumque cohortium duodecim pontis  
 tuendi causa ponit, magnisque eum locum munitionibus  
 15 firmat. <sup>3</sup> Ei loco praesidioque C. Volcatium Tullum  
 adulescentem praefecit; ipse, cum maturescere frumenta  
 inciperent, ad bellum Ambiorigis profectus, per Ardu-  
 ennâ silvam — quae est totius Galliae maxima, atque ab  
 ripis Rheni finibusque Treverorum ad Nervios pertinet,  
 20 milibusque amplius quingentis in longitudinem patet —  
<sup>4</sup> L. Minucium Basilum cum omni equitatu praemittit,  
 si quid celeritate itineris atque opportunitate temporis  
 proficere possit; monet ut ignes in castris fieri prohi-  
 beat, ne qua ejus adventus procul significatio fiat: sese  
 25 confestim subsequi dicit.

30. Basilus ut imperatum est facit: celeriter contra-  
 que omnium opinionem confecto itinere, multos in agris  
 inopinantes apprehendit; eorum indicio ad ipsum Am-  
 biorigem contendit, quo in loco cum paucis equitibus  
 esse dicebatur. <sup>2</sup> Multum cum in omnibus rebus tum  
 in re militari potest fortuna. Nam *sicut* magno accidit  
 casu, ut in ipsum incautum etiam atque imparatum in-  
 cideret, priusque ejus adventus ab omnibus videretur  
 quam fama ac nuntius adferretur, sic magnae fuit for-  
 35 tunae, omni militari instrumento quod circum se habe-

bat erepto, rhedis equisque comprehensis, ipsum effugere mortem. <sup>3</sup> Sed hoc quoque factum est, quod, aedificio circumdato silva, ut sunt fere domicilia Gallorum, qui vitandi aestus causa plerumque silvarum ac fluminum petunt propinquitates, comites familiaresque ejus angusto in loco paulisper equitum nostrorum vim sustinerunt. <sup>4</sup> His pugnantibus, illum in equum quidam ex suis intulit; fugientem silvae texerunt. Sic et ad subeundum periculum et ad vitandum, multum fortuna valuit.

31. Ambiorix copias suas judicione non conduxerit, quod proelio dimicandum non existimarit, an tempore exclusus et repentino equitum adventu prohibitus, cum reliquum exercitum subsequi crederet, dubium est. <sup>2</sup> Sed certe, dimissis per agros nuntiis, sibi quemque consulere jussit. Quorum pars in Arduennam silvam, pars in continentes paludes profugit; qui proximi Oceano fuerunt, his insulis sese occultaverunt quas aestus efficere consuerunt; multi ex suis finibus egressi se suaque omnia alienissimis crediderunt. <sup>3</sup> Catuvolcus, rex dimidiae partis Eburonum, qui una cum Ambiorige consilium inierat, aetate jam confectus, cum laborem aut belli aut fugae ferre non posset, omnibus precibus detestatus Ambiorigem, qui ejus consilii auctor fuisset, taxo (cujus magna in Gallia Germaniaque copia est) se exanimavit.

32. Segni Condrusique, ex gente et numero Germanorum, qui sunt inter Eburones Treverosque, legatos ad Caesarem miserunt, oratum, 'ne se in hostium numero duceret, neve omnium Germanorum qui essent citra Rhenum, unam esse causam judicaret; nihil se de bello cogitavisse, nulla Ambiorigi auxilia misisse.' <sup>2</sup> Caesar, explorata re quaestione captivorum, si qui ad eos Eburones ex fuga convenissent ad se ut reducerentur imperavit: si ita fecissent, fines eorum se violaturum negavit. <sup>3</sup> Tum copiis in tres partes distributis, impedimenta om-



longius evocabat, et silvae incertis occultisque itineribus confertos adire prohibebant. <sup>5</sup> Si negotium confici stirpemque hominum sceleratorum interfici vellet, dimittendae plures manus diducendique erant milites: si continere ad signa manipulos vellet, ut instituta ratio et <sup>5</sup> consuetudo exercitus Romani postulabat, locus ipse erat praesidio barbaris, neque ex occulto insidiandi et dispersos circumveniendi singulis deerat audacia. <sup>6</sup> Ut in ejusmodi difficultatibus, quantum diligentia provideri poterat, providebatur; ut potius in nocendo aliquid <sup>10</sup> praetermitteretur, etsi omnium animi ad ulciscendum ardebant, quam cum aliquo militum detrimento noceretur. <sup>7</sup> Dimittit ad finitimas civitates nuntios Caesar: omnes ad se vocat spe praedae ad diripiendos Eburones, ut potius in silvis Gallorum vita quam legionarius miles <sup>15</sup> periclitetur; simul ut, magna multitudine circumfusa, pro tali facinore stirps ac nomen civitatis tollatur. Magnus undique numerus celeriter convenit.

35. Haec in omnibus Eburonum partibus gerebantur, diesque appetebat septimus, quem ad diem Caesar ad <sup>20</sup> impedimenta legionemque reverti constituerat. <sup>2</sup> Hic quantum in bello fortuna possit, et quantos adferat casus, cognosci potuit. Dissipatis ac perterritis hostibus, ut demonstravimus, manus erat nulla quae parvam modo causam timoris afferret. <sup>3</sup> Trans Rhenum ad Germanos <sup>25</sup> pervenit fama, diripi Eburones atque ultro omnes ad praedam evocari. <sup>4</sup> Cogunt equitum duo milia Sugambri, qui sunt proximi Rheno, a quibus receptos ex fuga Tencteros atque Usipetes supra docuimus. <sup>5</sup> Transeunt Rhenum navibus ratibusque, triginta milibus passuum <sup>30</sup> infra eum locum ubi pons erat perfectus praesidiumque ab Caesare relictum. Primos Eburonum fines adeunt; multos ex fuga dispersos excipiunt, magno pecoris numero, cujus sunt cupidissimi barbari, potiuntur. <sup>6</sup> In-  
vitati praeda longius procedunt: non hos palus, in bello <sup>35</sup> latrociniisque natos, non silvae morantur. Quibus in

locis sit Caesar ex captivis quaerunt ; profectum longius reperiunt omnemque exercitum discessisse cognoscunt. <sup>7</sup>Atque unus ex captivis : “ Quid vos,” inquit, “ hanc miseram ac tenuem sectamini praedam, quibus licet jam esse fortunatissimis? Tribus horis Aduatucam venire potestis : huc omnes suas fortunas exercitus Romanorum contulit. Praesidii tantum est, ut ne murus quidem cingi possit, neque quisquam egredi extra munitiones audeat.” <sup>8</sup>Oblata spe, Germani quam nacti erant praedam in occulto relinquunt ; ipsi Aduatucam contendunt, usi eodem duce cujus haec indicio cognoverant.

36. Cicero (qui omnes superiores dies praeceptis Caesaris summa diligentia milites in castris continisset, ac ne calonem quidem quemquam extra munitionem egredi passus esset) septimo die, diffidens de numero dierum Caesarem fidem servaturum, quod longius progressum audiebat, neque ulla de reditu ejus fama afferebatur ; <sup>2</sup>simul eorum permotus vocibus, qui illius patientiam paene obsessionem appellabant, siquidem ex castris egredi non liceret ; nullum ejusmodi casum expectans, quo, novem oppositis legionibus maximoque equitatu, dispersis ac paene deletis hostibus, in milibus passuum tribus offendi posset, — quinque cohortes frumentatum in proximas segetes mittit, quas inter et castra unus omnino collis intererat. <sup>3</sup>Complures erant ex legionibus aegri relictis ; ex quibus qui hoc spatio dierum convaluerant, circiter trecenti, sub vexillo una mittuntur ; magna praeterea multitudo calonum, magna vis jumentorum, quae in castris subsederant, facta potestate sequitur.

37. Hoc ipso tempore et casu Germani equites interveniunt, protinusque eodem illo quo venerant cursu ab decumana porta in castra irrumpere conantur ; nec prius sunt visi, objectis ab ea parte silvis, quam castris appropinquarent, usque eo ut qui sub vallo tenderent

mercatores recipiendi sui facultatem non haberent.  
<sup>2</sup> Inopinantes nostri re nova perturbantur, ac vix primum impetum cohors in statione sustinet. Circumfunduntur ex reliquis hostes partibus, si quem aditum reperire possent. <sup>3</sup> Aegre portas nostri tuentur, reliquos aditus <sup>5</sup> locus ipse per se munitioque defendit. Totis trepidatur castris, atque alius ex alio causam tumultus quaerit; neque quo signa ferantur neque quam in partem quisque conveniat provident. <sup>4</sup> Alius jam castra capta pronuntiat; alius, deleto exercitu atque imperatore, victores <sup>10</sup> barbaros venisse contendit; plerique novas sibi ex loco religiones fingunt, Cottaque et Titurii calamitatem, qui in eodem occiderint castello, ante oculos ponunt. <sup>5</sup> Tali timore omnibus perterritis, confirmatur opinio barbaris, ut ex captivo audierant, nullum esse intus praesidium. <sup>15</sup> Perrumpere nituntur, seque ipsi adhortantur, ne tantam fortunam ex manibus dimittant.

38. Erat aeger cum praesidio relictus P. Sextius Baculus, qui primum pilum ad Caesarem duxerat, cujus mentionem superioribus proeliis fecimus, ac diem jam <sup>20</sup> quintum cibo caruerat. <sup>2</sup> Hic, diffusus suae atque omnium salutis, inermis ex tabernaculo prodit; videt imminere hostes atque in summo rem esse discrimine; capit arma a proximis atque in porta consistit: consequuntur hunc centuriones ejus cohortis quae in statione erat; <sup>25</sup> paulisper una proelium sustinent. <sup>3</sup> Relinquit animus Sextium, gravibus acceptis vulneribus: aegre per manus tractus servatur. Hoc spatio interposito, reliqui sese confirmant tantum, ut in munitionibus consistere audeant speciemque defensorum praebeant. <sup>30</sup>

39. Interim, confecta frumentatione, milites nostri clamorem exaudiunt: praecurrunt equites; quanto res sit in periculo cognoscunt. <sup>2</sup> Hic vero nulla munitio est quae perterritos recipiat: modo conscripti atque usus <sup>35</sup> militaris imperiti, ad tribunum militum centurionesque ora convertunt; quid ab his praecipiat exspectant:

nemo est tam fortis quin rei novitate perturbetur.  
 3 Barbari, signa procul conspicati, oppugnatione desistunt :  
 redisse primo legiones credunt, quas longius discessisse  
 ex captivis cognoverant : postea, despecta paucitate, ex  
 5 omnibus partibus impetum faciunt.

40. Calones in proximum tumulum procurrant. Hinc  
 celeriter dejecti se in signa manipulosque coniciunt : eo  
 magis timidos perterrent milites. 2 Alii, cuneo facto, ut  
 celeriter perrumpant censent, quoniam tam propinqua  
 10 sint castra ; et si pars aliqua circumventa ceciderit, at  
 reliquos servari posse confidunt ; alii ut in jugo consis-  
 tant atque eundem omnes ferant casum. 3 Hoc veteres  
 non probant milites, quos sub vexillo una profectos do-  
 cuimus. Itaque inter se cohortati, duce C. Trebonio,  
 15 equite Romano, qui eis erat praepositus, per medios  
 hostes perrumpunt, incolumesque ad unum omnes in  
 castra perveniunt. 4 Hos subsecuti calones equitesque  
 eodem impetu militum virtute servantur. At ii qui in  
 jugo constiterant, nullo etiam nunc usu rei militaris  
 20 percepto, neque in eo quod probaverant consilio permanere,  
 ut se loco superiore defenderent, neque eam quam  
 prodesse aliis vim celeritatemque viderant imitari potue-  
 runt ; sed se in castra recipere conati, iniquum in locum  
 demiserunt. 5 Centuriones, quorum nonnulli ex inferioribus  
 25 ordinibus reliquarum legionum virtutis causa in superiores  
 erant ordines hujus legionis traducti, ne ante  
 partam rei militaris laudem amitterent, fortissime pug-  
 nantes conciderunt. 6 Militum pars, horum virtute sub-  
 motis hostibus, praeter spem incolumis in castra pervenit ;  
 30 pars a barbaris circumventa periit.

41. Germani, desperata expugnatione castrorum, quod  
 nostros jam constitisse in munitionibus videbant, cum  
 ea praeda quam in silvis deposuerant trans Rhenum  
 sese receperunt. 2 Ac tantus fuit etiam post discessum  
 35 hostium terror, ut ea nocte, cum C. Volusenus missus  
 cum equitatu ad castra venisset, fidem non faceret adesse



cum incolumi Caesarem exercitu. <sup>3</sup> Sic omnino animos timor praeoccupaverat, ut, paene alienata mente, deletis omnibus copiis, equitatum tantum se ex fuga recepisse dicerent, neque incolumi exercitu Germanos castra oppugnatos fuisse contenderent. Quem timorem Caesaris adventus sustulit.

42. Réversus ille, — eventus belli non ignorans, unum quod cohortes ex statione et praesidio essent emissae questus, ne minimo quidem casu locum relinquere debuisset, — multum fortunam in repentino hostium adventu perperuisse judicavit; multo etiam amplius, quod paene ab ipso vallo portisque castrorum barbaros avertisset. <sup>2</sup> Quarum omnium rerum maxime admirandum videbatur, quod Germani, qui eo consilio Rhenum transierant ut Ambiorigis fines depopularentur, ad castra Romanorum delati, optatissimum Ambiorigi beneficium obtulerunt.

43. Caesar, rursus ad vexandos hostes profectus, magno coacto numero ex finitimis civitatibus, in omnes partes dimittit. <sup>2</sup> Omnes vici atque omnia aedificia quae quisque conspexerat incendebantur; praeda ex omnibus locis agebatur; frumenta non solum tanta multitudine jumentorum atque hominum consumebantur, sed etiam anni tempore atque imbribus procubuerant; ut, si qui etiam in praesentia se occultassent, tamen his, deducto exercitu, rerum omnium inopia pereundum videretur.

<sup>3</sup> Ac saepe in eum locum ventum est, tanto in omnes partes diviso equitatu, ut modo visum ab se Ambiorigem in fuga circumspicerent captivi, nec plane etiam abesse ex conspectu contenderent; ut, spe consequendi illata atque infinito labore suscepto, qui se summam ab Caesare gratiam inituros putarent, paene naturam studio vincerent, semperque paulum ad summam felicitatem defuisse videretur; <sup>4</sup> atque ille latebris aut saltibus se eriperet; et noctu occultatus alias regiones partesque peteret, non majore equitum praesidio quam quattuor, quibus solis vitam suam committere audebat.

44. Tali modo vastatis regionibus, exercitum Caesar  
duarum cohortium damno Durocortorum Remorum re-  
ducit ; concilioque in eum locum Galliae indicto, de con-  
jurazione Senonum et Carnutum quaestionem habere  
5 instituit, et de Accone, qui princeps ejus consilii fuerat,  
graviore sententia pronuntiata, more majorum suppli-  
cium sumpsit. <sup>2</sup> Nonnulli judicium veriti profugerunt :  
quibus cum aqua atque igni interdixisset, duas legiones  
ad fines Treverorum, duas in Lingonibus, sex reliquas  
10 in Senonum finibus Agendici in hibernis collocavit ;  
frumentoque exercitui proviso, ut instituerat, in Italiam  
ad conventus agendos profectus est.



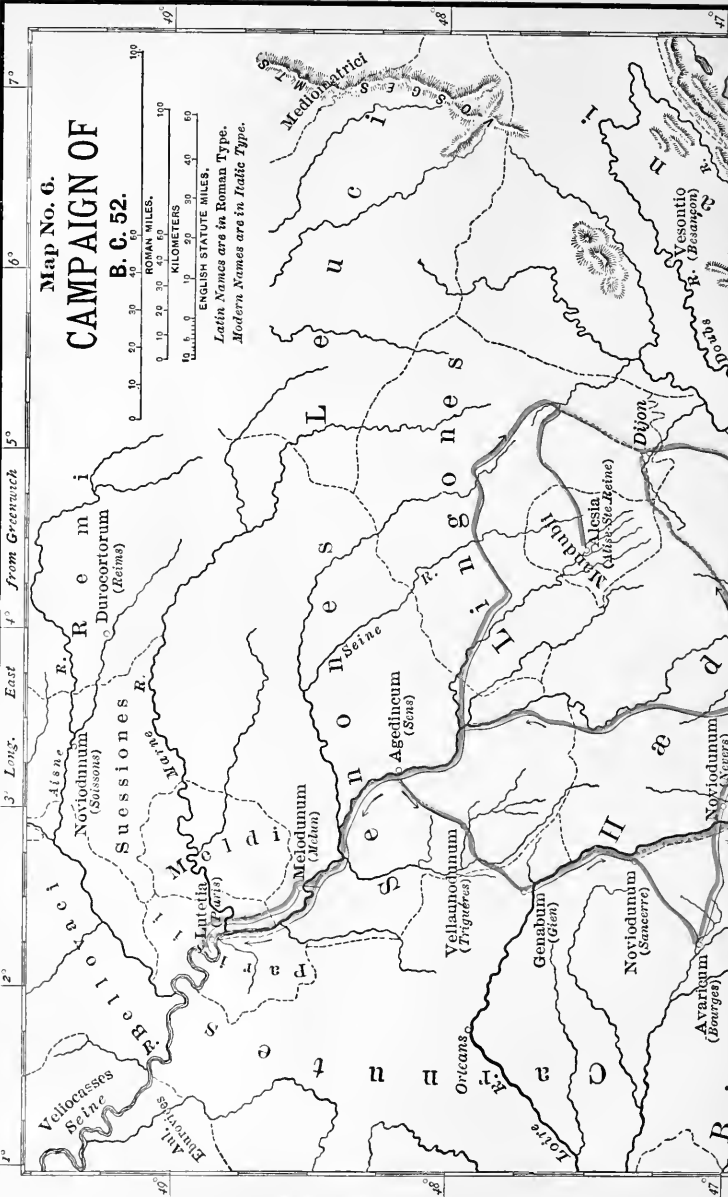

Map No. 6.  
**CAMPAIGN OF  
 B. C. 52.**

ROMAN MILES,  
 0 10 20 30 40 50 60 70 80 90 100  
 ENGLISH STATUTE MILES,  
 0 10 20 30 40 50 60 70 80 90 100  
 KILOMETERS,  
 0 10 20 30 40 50 60 70 80 90 100

*Latin Names are in Roman Type.  
 Modern Names are in Italic Type.*

1° 2° 3° Long. East 4° 5° 6° 7°

47° 48° 49°

Vellodunum (Saucy)  
 Vellodunum (Triguères)  
 Vellodunum (Sancti)

Noviodunum (Sens)  
 Noviodunum (Noyers)  
 Noviodunum (Sancti)

Noviodunum (Sens)  
 Noviodunum (Noyers)  
 Noviodunum (Sancti)

Noviodunum (Sens)  
 Noviodunum (Noyers)  
 Noviodunum (Sancti)

Noviodunum (Sens)  
 Noviodunum (Noyers)  
 Noviodunum (Sancti)

Noviodunum (Sens)  
 Noviodunum (Noyers)  
 Noviodunum (Sancti)

Noviodunum (Sens)  
 Noviodunum (Noyers)  
 Noviodunum (Sancti)

Noviodunum (Sens)  
 Noviodunum (Noyers)  
 Noviodunum (Sancti)

Noviodunum (Sens)  
 Noviodunum (Noyers)  
 Noviodunum (Sancti)

Noviodunum (Sens)  
 Noviodunum (Noyers)  
 Noviodunum (Sancti)

Noviodunum (Sens)  
 Noviodunum (Noyers)  
 Noviodunum (Sancti)

Noviodunum (Sens)  
 Noviodunum (Noyers)  
 Noviodunum (Sancti)

Noviodunum (Sens)  
 Noviodunum (Noyers)  
 Noviodunum (Sancti)

Noviodunum (Sens)  
 Noviodunum (Noyers)  
 Noviodunum (Sancti)

Noviodunum (Sens)  
 Noviodunum (Noyers)  
 Noviodunum (Sancti)

Noviodunum (Sens)  
 Noviodunum (Noyers)  
 Noviodunum (Sancti)

Noviodunum (Sens)  
 Noviodunum (Noyers)  
 Noviodunum (Sancti)

Noviodunum (Sens)  
 Noviodunum (Noyers)  
 Noviodunum (Sancti)

Noviodunum (Sens)  
 Noviodunum (Noyers)  
 Noviodunum (Sancti)

Noviodunum (Sens)  
 Noviodunum (Noyers)  
 Noviodunum (Sancti)

Noviodunum (Sens)  
 Noviodunum (Noyers)  
 Noviodunum (Sancti)

Noviodunum (Sens)  
 Noviodunum (Noyers)  
 Noviodunum (Sancti)

Noviodunum (Sens)  
 Noviodunum (Noyers)  
 Noviodunum (Sancti)

Noviodunum (Sens)  
 Noviodunum (Noyers)  
 Noviodunum (Sancti)

Noviodunum (Sens)  
 Noviodunum (Noyers)  
 Noviodunum (Sancti)

Noviodunum (Sens)  
 Noviodunum (Noyers)  
 Noviodunum (Sancti)

Noviodunum (Sens)  
 Noviodunum (Noyers)  
 Noviodunum (Sancti)

Noviodunum (Sens)  
 Noviodunum (Noyers)  
 Noviodunum (Sancti)

Noviodunum (Sens)  
 Noviodunum (Noyers)  
 Noviodunum (Sancti)

Noviodunum (Sens)  
 Noviodunum (Noyers)  
 Noviodunum (Sancti)

Noviodunum (Sens)  
 Noviodunum (Noyers)  
 Noviodunum (Sancti)

Noviodunum (Sens)  
 Noviodunum (Noyers)  
 Noviodunum (Sancti)

Noviodunum (Sens)  
 Noviodunum (Noyers)  
 Noviodunum (Sancti)

Noviodunum (Sens)  
 Noviodunum (Noyers)  
 Noviodunum (Sancti)

Noviodunum (Sens)  
 Noviodunum (Noyers)  
 Noviodunum (Sancti)

Noviodunum (Sens)  
 Noviodunum (Noyers)  
 Noviodunum (Sancti)

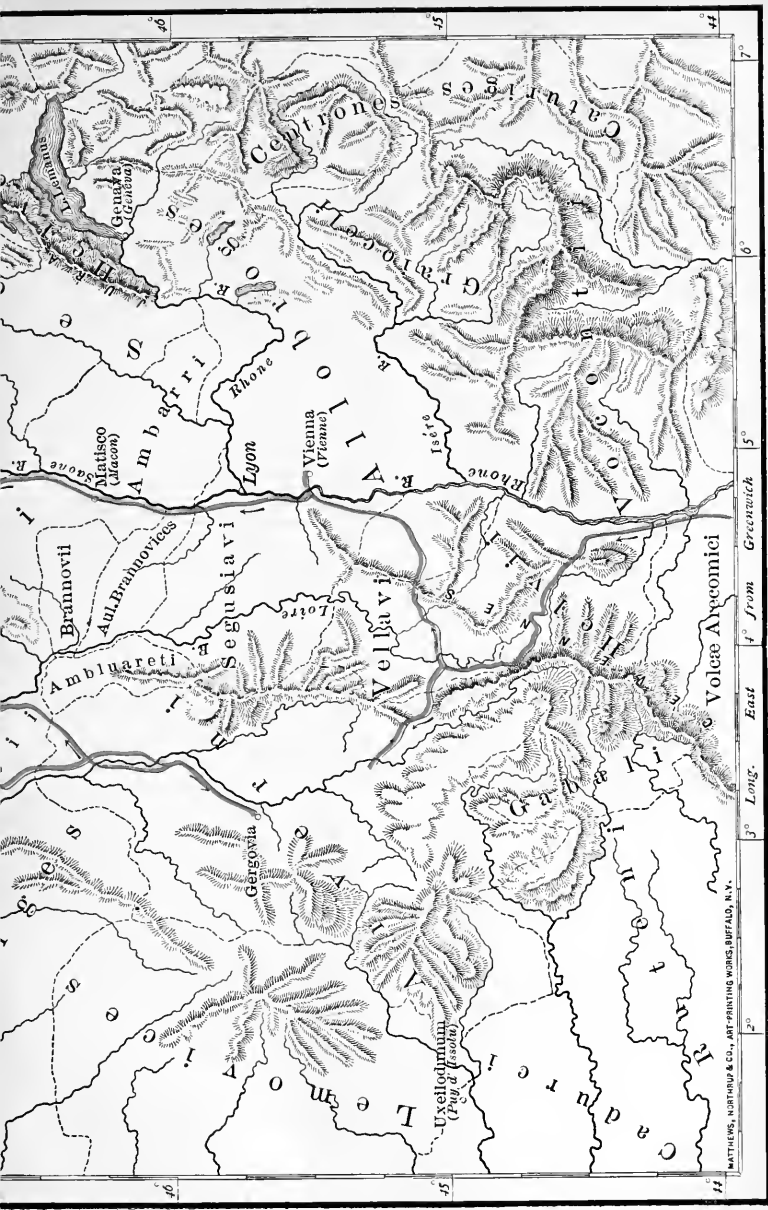

MATHEWS, NORTHROP & CO., ART-PRINTING WORKS, BUFFALO, N. Y.

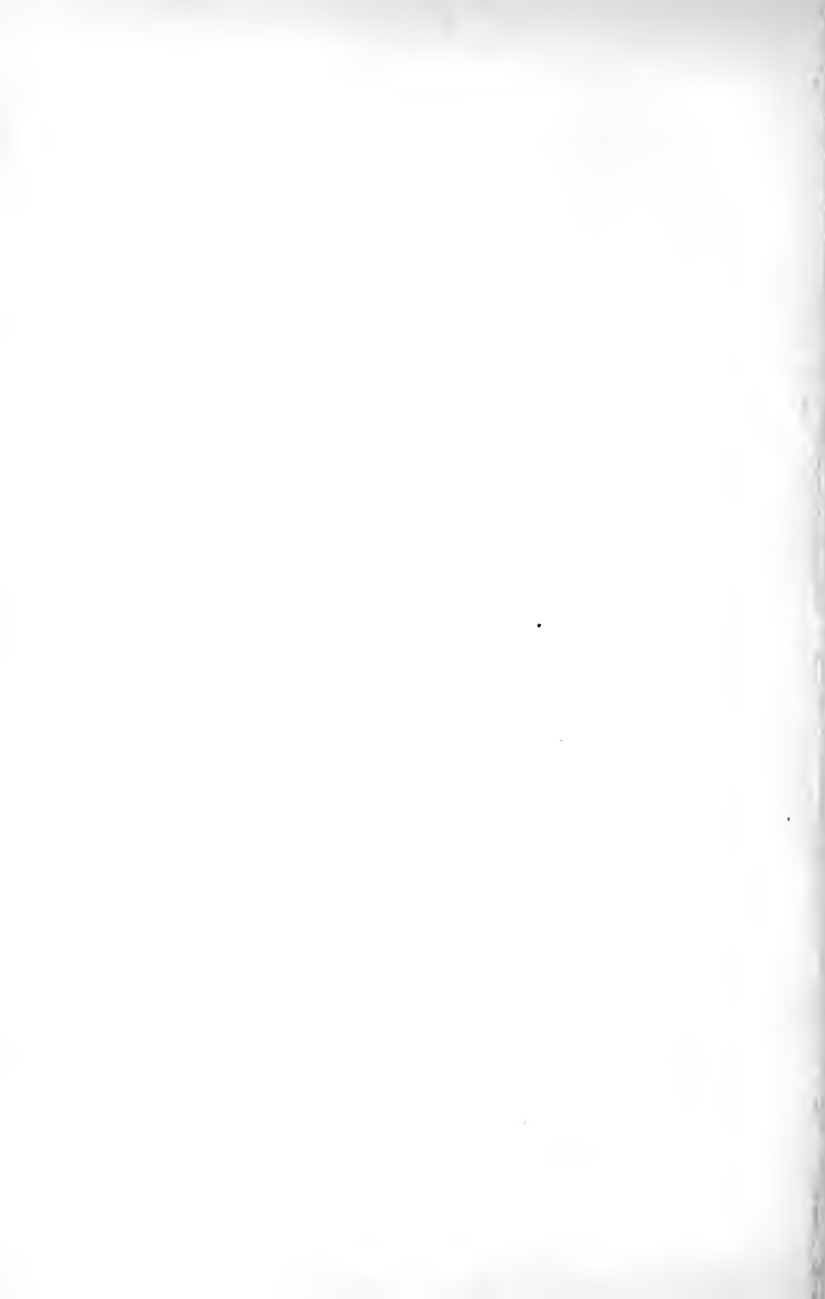

## BOOK VII.

UPRISING OF GAUL UNDER VERCINGETORIX. — News of tumults in Rome following the murder of Clodius move the Gauls to another effort for independence: their rising begins in the south (*Auvergne*) under Vercingetorix (1-5). Rapid and perilous march of Cæsar upon the Arverni (6-8). Difficulties of his advance; he crosses the Loire (9-11); he captures several towns and advances upon Avaricum (*Bourges*), which is hard pressed by the Gauls (12-19). Suspicions against Vercingetorix, who is enthusiastically acquitted by his countrymen (20, 21). The siege and storming of Avaricum (23-28). Vercingetorix gallantly maintains the war (29-31). Cæsar composes troubles arising among the Ædui, and lays siege to Gergovia (32-36). Appeal of Litavicus to the Ædui: they submit to Cæsar, and Litavicus takes flight (37-40). Attack on the Roman camp at Gergovia; new troubles among the Ædui (41-43). Cæsar attempts the storming of Gergovia, but is repelled, and raises the siege (44-53). Actions in central Gaul; revolt of the Ædui, and able conduct of Labienus (54-62). Vercingetorix is recognized chief throughout Gaul; but is worsted by the Roman and German cavalry, and takes refuge in Alesia, whence he calls for a general levy of the Gauls (63-71). Siege and distress of Alesia; relief is sent to the besieged, but repulsed by Cæsar (72-80). The Gauls attack the Roman camp on both sides, and a desperate struggle ensues; they are at length wholly subdued, and Vercingetorix surrenders (81-89). The pacification of Gaul is completed by Cæsar's officers (90).

QUIETA Gallia, Caesar, ut constituerat, in Italiam ad conventus agendos proficiscitur. Ibi cognoscit de Clodii caede; senatusque consulto certior factus ut omnes juniores Italiae conjurarent, delectum tota provincia habere instituit. <sup>2</sup> Eae res in Galliam Transalpinam celeriter perferuntur. Addunt ipsi et affingunt rumoribus Galli (quod res poscere videbatur) retineri urbano motu Caesarem, neque in tantis dissensionibus ad

exercitum venire posse. <sup>3</sup> Hac impulsione occasione, qui jam ante se populi Romani imperio subjectos dolerent, liberius atque audacius de bello consilia inire incipiunt. <sup>4</sup> Indictis inter se principes Galliae conciliis silvestribus  
 5 ac remotis locis, queruntur de Acconis morte; posse hunc casum ad ipsos recidere demonstrant; miserantur communem Galliae fortunam; omnibus pollicitationibus ac praemiis deprecantur qui belli initium faciant, et sui capitis periculo Galliam in libertatem vindicent. <sup>5</sup> Im-  
 10 primis rationem esse habendam dicunt, priusquam eorum clandestina consilia efferantur, ut Caesar ab exercitu intercludatur. <sup>6</sup> Id esse facile, quod neque legiones audent absente imperatore ex hibernis egredi, neque imperator sine praesidio ad legiones pervenire possit;  
 15 postremo, in acie praestare interfici, quam non veterem belli gloriam libertatemque quam a majoribus acceperint recuperare.

2. His rebus agitata, profitentur Carnutes se nullum periculum communis salutis causa recusare, principesque  
 20 ex omnibus bellum facturos pollicentur; <sup>2</sup> et, quoniam in praesentia obsidibus cavere inter se non possint, ne res efferatur, ut jurejurando ac fide sanciantur petunt, collatis militaribus signis (quo more eorum gravissima caeremonia continetur), ne, facto initio belli, ab reliquis  
 25 deserantur. <sup>3</sup> Tum, collaudatis Carnutibus, dato jurejurando ab omnibus qui aderant, tempore ejus rei constituto, ab concilio disceditur.

3. Ubi ea dies venit, Carnutes, Cotuato et Conetodunno ducibus, desperatis hominibus, Genabum signo  
 30 dato concurrunt, civesque Romanos, qui negotiandi causa ibi constiterant, in his C. Fufium Citam, honestum equitem Romanum, qui rei frumentariae jussu Caesaris praeerat, interficiunt bonaque eorum diripiunt. <sup>2</sup> Celeriter ad omnes Galliae civitates fama perfertur. Nam ubi-  
 35 cumque major atque illustrior incidit res, clamore per agros regionesque significant; hunc alii deinceps ex-



cipiunt et proximis tradunt: ut tum accidit. <sup>3</sup>Nam quae Genabi oriente sole gesta essent, ante primam confectam vigiliam in finibus Arvernorum audita sunt; quod spatium est milium passuum circiter CLX.

4. Simili ratione ibi Vercingetorix, Celtilli filius, Arvernus, summae potentiae adulescens, — cujus pater principatum Galliae totius obtinuerat, et ob eam causam, quod regnum appetebat, ab civitate erat interfectus, — convocatis suis clientibus, facile incendit. <sup>2</sup>Cognito ejus consilio, ad arma concurritur. Prohibetur ab Gobbannitione, patruo suo, reliquisque principibus, qui hanc temptandam fortunam non existimabant; expellitur ex oppido Gergovia: non destitit tamen, atque in agris habet delectum egentium ac perditorum. <sup>3</sup>Hac coacta manu, quoscumque adit ex civitate, ad suam sententiam perducit; hortatur ut communis libertatis causa arma capiant; magnisque coactis copiis, adversarios suos, a quibus paulo ante erat ejectus, expellit ex civitate. <sup>4</sup>Rex ab suis appellatur. Dimittit quoque versus legationes; obtestatur ut in fide maneant. <sup>5</sup>Celeriter sibi Senones, Parisios, Pictones, Cadurcos, Turonos, Aulercos, Lemovices, Andos, reliquosque omnes qui Oceanum attingunt, adjungit: omnium consensu ad eum defertur imperium. <sup>6</sup>Qua oblata potestate, omnibus his civitatibus obsides imperat; certum numerum militum ad se celeriter adduci jubet; armorum quantum quaeque civitas domi, quodque ante tempus efficiat, constituit. <sup>7</sup>Imprimis equitatu studet; summae diligentiae summam imperii severitatem addit; magnitudine supplicii dubitantes cogit: nam, majore commisso delicto, igni atque omnibus tormentis necat; levio de causa, auribus desectis aut singulis effossis oculis, domum remittit, ut sint reliquis documento, et magnitudine poenae perterreant alios.

5. His suppliciis celeriter coacto exercitu, Lucterium Cadurcum, summae hominem audaciae, cum parte copiarum in Rutenos mittit; ipse in Bituriges proficiscitur.

<sup>2</sup> Ejus adventu Bituriges ad Haeduos (quorum erant in fide) legatos mittunt subsidium rogatum, quo facilius hostium copias sustinere possint. Haedui de consilio legatorum, quos Caesar ad exercitum reliquerat, copias  
5 equitatus peditatusque subsidio Biturigibus mittunt.

<sup>3</sup> Qui cum ad flumen Ligerim venissent, quod Bituriges ab Haeduis dividit, paucos dies ibi morati, neque flumen transire ausi, domum revertuntur; legatisque nostris renuntiant, se Biturigum perfidiam veritos revertisse, qui-  
10 bus id consilii fuisse cognoverint, ut, si flumen transissent, una ex parte ipsi, altera Arverni se circumstiterent.

<sup>4</sup> Id eane de causa quam legatis pronuntiarunt, an perfidia adducti fecerint, quod nihil nobis constat, non videtur pro certo esse proponendum. Bituriges, eorum  
15 discessu, statim cum Arvernis junguntur.

6. His rebus in Italiam Caesari nuntiatis, cum jam ille urbanas res virtute Cn. Pompeii commodiorem in statum pervenisse intellexeret, in Transalpinam Galliam profectus est. <sup>2</sup> Eo cum venisset, magna difficultate  
20 afficiebatur, qua ratione ad exercitum pervenire posset.

<sup>3</sup> Nam si legiones in Provinciam accesserent, se absente in itinere proelio dimicaturas intellegebat: si ipse ad exercitum contenderet, ne iis quidem eo tempore qui quieti viderentur suam salutem recte committi videbat.

25 7. Interim Lucterius Cadurcus, in Rutenos missus, eam civitatem Arvernis conciliat. Progressus in Nitiobriges et Gabalos, ab utrisque obsides accipit, et, magna coacta manu, in Provinciam, Narbonem versus, eruptionem facere contendit. <sup>2</sup> Qua re nuntiata, Caesar omnibus consiliis anteverendum existimavit, ut Narbonem proficisceretur. <sup>3</sup> Eo cum venisset, timentes confirmat, praesidia in Rutenis provincialibus, Volcis Arecomicis, Tolosatibus, circumque Narbonem, quae loca hostibus erant finitima, constituit; partem copiarum ex Provincia,  
30 supplementumque quod ex Italia adduxerat in Helvios, qui fines Arvernorum contingunt, convenire jubet.

8. His rebus comparatis, represso jam Lucterio et remoto, quod intrare intra praesidia periculosum putabat, in Helvios proficiscitur. <sup>2</sup> Etsi mons Cevenna, qui Arvernos ab Helviis discludit, durissimo tempore anni altissima nive iter impediabat; tamen, discussa nive sex <sup>5</sup> in altitudinem pedum, atque ita viis patefactis, summo militum sudore ad fines Arvernorum pervenit. <sup>3</sup> Quibus oppressis inopinantibus, quod se Cevenna ut muro munitos existimabant, ac ne singulari quidem umquam homini eo tempore anni semitae patuerant, equitibus <sup>10</sup> imperat, ut quam latissime possint vagentur, et quam maximum hostibus terrorem inferant. <sup>4</sup> Celeriter haec fama ac nuntiis ad Vercingetorigem perferuntur; quem perterriti omnes Arverni circumsistunt, atque obsecrant ut suis fortunis consulat, neve ab hostibus diripiantur; <sup>15</sup> praesertim cum videat omne ad se bellum translatum. <sup>5</sup> Quorum ille precibus permotus, castra ex Biturigibus movet in Arvernos versus.

9. At Caesar, biduum in iis locis moratus, quod haec de Vercingetorige usu ventura opinione praeceperat, per <sup>20</sup> causam supplementi equitatusque cogendi ab exercitu discedit; Brutum adulescentem his copiis praeficit; hunc monet ut in omnes partes equites quam latissime pervagentur; daturum se operam ne longius triduo ab castris absit. <sup>2</sup> His constitutis rebus, suis inopinantibus, <sup>25</sup> quam maximis potest itineribus Viennam pervenit. <sup>3</sup> Ibi nactus recentem equitatum, quem multis ante diebus eo praemiserat, neque diurno neque nocturno itinere intermisso, per fines Haeduorum in Lingones contendit, ubi duae legiones hiemabant; ut, si quid etiam de sua <sup>30</sup> salute ab Haeduis iniretur consilii, celeritate praecurreret. <sup>4</sup> Eo cum pervenisset, ad reliquas legiones mittit, priusque omnes in unum locum cogit quam de ejus adventu Arvernus nuntiari posset. <sup>5</sup> Hac re cognita, Vercingetorix rursus in Bituriges exercitum reducit, atque <sup>35</sup> inde profectus Gorgobinam, Boiorum oppidum, quos ibi

Helvetico proelio victos Caesar collocaverat Haeduisque attribuerat, oppugnare instituit.

10. Magnam haec res Caesari difficultatem ad consilium capiendum afferebat: si reliquam partem hiemis  
 5 uno loco legiones contineret, ne, stipendiariis Haeduo-  
 rum expugnatis, cuncta Gallia deficeret, quod nullum  
 amicis in eo praesidium videretur positum esse: si matu-  
 rius ex hibernis educeret, ne ab re frumentaria duris  
 subvectionibus laboraret. <sup>2</sup> Praestare visum est tamen  
 10 omnes difficultates perpeti, quam, tanta contumelia ac-  
 cepta, omnium suorum voluntates alienare. <sup>3</sup> Itaque  
 cohortatus Haeduos de supportando commeatu, praemit-  
 tit ad Boios, qui de suo adventu doceant, hortenturque  
 ut in fide maneant, atque hostium impetum magno  
 15 animo sustineant. <sup>4</sup> Duabus Agedici legionibus atque  
 impedimentis totius exercitus relictis, ad Boios profi-  
 ciscitur.

11. Altero die, cum ad oppidum Senonum Vellaunodunum venisset, ne quem post se hostem relinqueret,  
 20 quo expeditiore re frumentaria uteretur, oppugnare in-  
 stituit, idque biduo circumvallavit; tertio die, missis ex  
 oppido legatis de deditioe, arma conferri, jumenta pro-  
 duci, sexcentos obsides dari, jubet: ea qui conficeret,  
 C. Trebonium legatum relinquit. <sup>2</sup> Ipse, ut quam pri-  
 25 mum iter faceret, Genabum Carnutum proficiscitur; qui,  
 tum primum allato nuntio de oppugnatione Vellaunoduni,  
 cum longius eam rem ductum iri existimarent,  
 praesidium Genabi tuendi causa, quod eo mitterent,  
 comparabant. <sup>3</sup> Huc biduo pervenit. Castris ante op-  
 30 pidum positis, diei tempore exclusus in posterum oppug-  
 nationem differt, quaeque ad eam rem usui sint militibus  
 imperat; et, quod oppidum Genabum pons fluminis Li-  
 geris continebat, veritus ne noctu ex oppido profugerent,  
 duas legiones in armis excubare jubet. <sup>4</sup> Genabenses,  
 35 paulo ante mediam noctem silentio ex oppido egressi,  
 flumen transire coeperunt. <sup>5</sup> Qua re per exploratores

nuntiata, Caesar legiones, quas expeditas esse jusserat, portis incensis, intromittit atque oppido potitur, perpau-  
cis ex hostium numero desideratis quin cuncti vivi cape-  
rentur, quod pontis atque itinerum angustiae multitudinis  
fugam intercluserant. <sup>6</sup>Oppidum diripit atque incendit, <sup>5</sup>  
praedam militibus donat; exercitum Ligerem traducit,  
atque in Biturigum fines pervenit.

12. Vercingetorix, ubi de Caesaris adventu cognovit,  
oppugnatione destitit atque obviam Caesari proficiscitur.  
Ille oppidum Biturigum positum in via Noviodunum <sup>10</sup>  
oppugnare instituerat. <sup>2</sup>Quo ex oppido cum legati ad  
eum venissent, oratum ut sibi ignosceret suaeque vitae  
consuleret, ut celeritate reliquas res conficeret qua plera-  
que erat consecutus, arma conferri, equos produci, obsides  
dari, jubet. <sup>3</sup>Parte jam obsidum tradita, cum reliqua <sup>15</sup>  
administrarentur, centurionibus et paucis militibus in-  
tromissis qui arma jumentaque conquirerent, equitatus  
hostium procul visus est, qui agmen Vercingetorigis  
antecesserat. <sup>4</sup>Quem simul atque oppidani conspexe-  
runt atque in spem auxilii venerunt, clamore sublato, <sup>20</sup>  
arma capere, portas claudere, murum complere coepe-  
runt. <sup>5</sup>Centuriones in oppido, cum ex significatione  
Gallorum novi aliquid ab his iniri consilii intellexissent,  
gladiis dstrictis, portas occupaverunt suosque omnes  
incolumes receperunt. <sup>25</sup>

13. Caesar ex castris equitatum educi jubet, proelium-  
que equestre committit: laborantibus jam suis Germanos  
equites circiter cccc submittit, quos ab initio habere  
secum instituerat. <sup>2</sup>Eorum impetum Galli sustinere  
non potuerunt, atque in fugam conjecti, multis amissis, <sup>30</sup>  
se ad agmen receperunt; quibus profligatis, rursus op-  
pidani perterriti comprehensos eos, quorum opera plebem  
concitata existimabant, ad Caesarem perduxerunt sese-  
que ei dederunt. <sup>3</sup>Quibus rebus confectis, Caesar ad  
oppidum Avaricum, quod erat maximum munitissimum- <sup>35</sup>  
que in finibus Biturigum atque agri fertilissima regione,

profectus est ; quod, eo oppido recepto, civitatem Biturigum se in potestatem redacturum confidebat.

14. Vercingetorix, tot continuis incommodis Vellau-  
 noduni, Genabi, Novioduni acceptis, suos ad concilium  
 5 convocat. <sup>2</sup> Docet, 'longe alia ratione esse bellum geren-  
 dum atque antea gestum sit ; omnibus modis huic rei  
 studendum, ut pabulatione et commeatu Romani prohi-  
 beantur : id esse facile, quod equitatu ipsi abundant, et  
 quod anni tempore sublevantur ; pabulum secari non  
 10 posse ; necessario dispersos hostes ex aedificiis petere :  
 hos omnes cotidie ab equitibus deleri posse. <sup>3</sup> Praete-  
 rea, salutis causa, rei familiaris commoda negligenda ;  
 vicos atque aedificia incendi oportere hoc spatio [a Boia]  
 quoque versus, quo pabulandi causa adire posse videan-  
 15 tur. <sup>4</sup> Harum ipsis rerum copiam suppetere, quod quo-  
 rum in finibus bellum geratur, eorum opibus sublevantur.  
 Romanos aut inopiam non laturos, aut magno periculo  
 longius ab castris processuros ; neque interesse, ipsosne  
 interficiant impedimentisne exuant, quibus amissis bel-  
 20 lum geri non possit. <sup>5</sup> Praeterea, oppida incendi oportere  
 quae non munitione et loci natura ab omni sint  
 periculo tuta : neu suis sint ad detractandam militiam  
 receptacula, neu Romanis proposita ad copiam commea-  
 tus praedamque tollendam. <sup>6</sup> Haec si gravia aut acerba  
 25 videantur, multo illa gravius aestimare, liberos, conjuges  
 in servitutem abstrahi, ipsos interfici ; quae sit necesse  
 accidere victis.'

15. Omnium consensu hac sententia probata, uno die  
 amplius xx urbes Biturigum incenduntur. Hoc idem fit  
 30 in reliquis civitatibus. <sup>2</sup> In omnibus partibus incendia  
 conspiciuntur ; quae etsi magno cum dolore omnes fere-  
 bant, tamen hoc sibi solatii proponebant, quod se, prope  
 explorata victoria, celeriter amissa recuperaturos con-  
 fidebant. <sup>3</sup> Deliberatur de Avarico in communi concilio,  
 35 incendi placeret an defendi. <sup>4</sup> Procumbunt omnibus  
 Gallis ad pedes Bituriges, ne pulcherrimam prope to-

tius Galliae urbem, quae praesidio et ornamento sit civitati, suis manibus succendere cogentur; facile se loci natura defensuros dicunt, quod, prope ex omnibus partibus flumine et palude circumdata, unum habeat et perangustum aditum. <sup>5</sup> Datur petentibus venia, dissuadente primo Vercingetorige, post concedente, et precibus ipsorum et misericordia volgi. Defensores oppido idonei deliguntur.

16. Vercingetorix minoribus Caesarem itineribus subsequitur, et locum castris deligit paludibus silvisque <sup>10</sup> munitum, ab Avarico longe milia passuum xvi. <sup>2</sup> Ibi per certos exploratores in singula diei tempora quae ad Avaricum agerentur cognoscebat, et quid fieri vellet imperabat. <sup>3</sup> Omnes nostras pabulationes frumentationesque observabat, dispersosque, cum longius necessario <sup>15</sup> procederent, adoriebatur magnoque incommodo afficiebat; etsi, quantum ratione provideri poterat, ab nostris occurrebatur, ut incertis temporibus diversisque itineribus iretur.

17. Castris ad eam partem oppidi positis Caesar, quae <sup>20</sup> intermissa a flumine et a palude aditum, ut supra diximus, angustum habebat, aggerem apparare, vineas agere, tures duas constituere coepit: nam circumvallare loci natura prohibebat. <sup>2</sup> De re frumentaria Boios atque Haeduos adhortari non destitit: quorum alteri, quod <sup>25</sup> nullo studio agebant, non multum adjuvabant; alteri non magnis facultatibus, quod civitas erat exigua et infirma, celeriter quod habuerunt consumpserunt. <sup>3</sup> Summa difficultate rei frumentariae affecto exercitu, tenuitate Boiorum, indiligentia Haeduorum, incendiis aedificiorum, <sup>30</sup> — usque eo ut complures dies frumento milites caruerint, et, pecore e longinquiribus vicis adacto, extremam famem sustentarent, — nulla tamen vox est ab iis audita populi Romani majestate et superioribus victoriis indigna. <sup>4</sup> Quin etiam Caesar cum in opere singulas <sup>35</sup> legiones appellaret, et, si acerbius inopiam ferrent, se

dimissurum oppugnationem diceret, universi ab eo ne id faceret petebant: <sup>5</sup> 'sic se complures annos, illo imperante, meruisse, ut nullam ignominiam acciperent, nusquam infecta re discederent; hoc se ignominiae la-  
 5 turos loco, si inceptam oppugnationem reliquissent: <sup>6</sup> praestare omnes perferre acerbitates quam non civibus Romanis, qui Genabi perfidia Gallorum interissent, parentarent.' Haec eadem centurionibus tribunisque militum mandabant, ut per eos ad Caesarem deferrentur.

10 18. Cum jam muro tures appropinquassent, ex captivis Caesar cognovit Vercingetorigem, consumpto pabulo, castra movisse propius Avaricum, atque ipsum cum equitatu expeditisque, qui inter equites proeliari consuessent, insidiarum causa eo profectum, quo nostros  
 15 postero die pabulatum venturos arbitraretur. <sup>2</sup> Quibus rebus cognitis, media nocte silentio profectus ad hostium castra mane pervenit. <sup>3</sup> Illi, celeriter per exploratores adventu Caesaris cognito, carros impedimenta que sua in artiores silvas abdiderunt, copias omnes in loco  
 20 edito atque aperto instruxerunt. <sup>4</sup> Qua re nuntiata, Caesar celeriter sarcinas conferri, arma expediti jussit.

19. Collis erat leniter ab infimo acclivis. Hunc ex omnibus fere partibus palus difficilis atque impedita cingebat, non latior pedibus quinquaginta. <sup>2</sup> Hoc se colle,  
 25 interruptis pontibus, Galli fiducia loci continebant, generatimque distributi in civitates, omnia vada ac † saltus ejus paludis obtinebant, sic animo parati ut, si eam paludem Romani perrumpere conarentur, haesitantes premerent ex loco superiore: <sup>3</sup> ut, qui propinquitatem loci  
 30 videret, paratos prope aequo Marte ad dimicandum existimaret; qui iniquitatem condicionis perspiceret, inani simulatione sese ostentare cognosceret. <sup>4</sup> Indignantibus milites Caesar, quod conspectum suum hostes perferre possent, tantulo spatio interjecto, et signum proelii expos-  
 35 centes, edocet quanto detrimento et quot virorum fortium morte necesse sit constare victoriam; <sup>5</sup> quos cum sic



animo paratos videat ut nullum pro sua laude periculum recusent, summae se iniquitatis condemnari debere, nisi eorum vitam sua salute habeat cariorem. <sup>6</sup> Sic milites consolatus eodem die reducit in castra; reliquaque quae ad oppugnationem pertinebant oppidi administrare instituit. 5

20. Vercingetorix, cum ad suos redisset, proditionis insimulatus, — quod castra propius Romanos movisset, quod cum omni equitatu discessisset, quod sine imperio tantas copias reliquisset, quod ejus discessu Romani <sup>10</sup> tanta opportunitate et celeritate venissent; non haec omnia fortuito aut sine consilio accidere potuisse; regnum illum Galliae malle Caesaris concessu quam ipsorum habere beneficio, — tali modo accusatus, ad haec respondit: <sup>2</sup> ‘Quod castra movisset, factum inopia pabuli, <sup>15</sup> etiam ipsis hortantibus; quod propius Romanos accessisset, persuasum loci opportunitate, qui se † ipsum munitione defenderet; equitum vero operam neque in loco palustri desiderari debuisse, et illic fuisse utilem quo sint profecti. <sup>3</sup> Summam imperii se consulto nulli discedentem tradidisse, ne is multitudinis studio ad dimicandum impelleretur; cui rei propter animi mollietiam studere omnes videret, quod diutius laborem ferre non possent. <sup>4</sup> Romani si casu intervenerint, fortunae; si alicujus indicio vocati, huic habendam gratiam, quod et <sup>25</sup> paucitatem eorum ex loco superiore cognoscere et virtutem despiciere potuerint; qui dimicare non ausi turpiter se in castra receperint. <sup>5</sup> Imperium se ab Caesare per proditionem nullum desiderare, quod habere victoria posset, quae jam esset sibi atque omnibus Gallis explorata: quin etiam ipsis remittere, si sibi magis honorem tribuere quam ab se salutem accipere videantur.’ <sup>6</sup> “Haec ut intelligatis,” inquit, “a me sincere pronuntiari, audite Romanos milites.” Producit servos, quos in pabulatione paucis ante diebus exceperat, et fame vinculisque excrucia- <sup>35</sup> verat. <sup>7</sup> Hi, jam ante edocti quae interrogati pro-

nuntiarent, milites se esse legionarios dicunt; fame et inopia adductos clam ex castris exisse, si quid frumenti aut pecoris in agris reperire possent; simili omnem exercitum inopia premi, nec jam vires sufficere cujusquam, nec ferre operis laborem posse: itaque statuisset imperatorem, si nihil in oppugnatione oppidi profecissent, triduo exercitum deducere. <sup>8</sup>“Haec,” inquit, “a me,” Vercingetorix, “beneficia habetis, quem proditionis insimulatis; cujus opera sine vestro sanguine tantum exercitum victorem fame consumptum videtis; quem turpiter se ex hac fuga recipientem, ne qua civitas suis finibus recipiat, a me provisum est.”

21. Conclamat omnis multitudo, et suo more armis concrepat, — quod facere in eo consuerunt cujus orationem approbant; summum esse Vercingetorigem ducem, nec de ejus fide dubitandum, nec majore ratione bellum administrari posse. <sup>2</sup>Statuunt, ut decem milia hominum delecta ex omnibus copiis in oppidum mittantur, nec solis Biturigibus communem salutem committendam censent; quod paene in eo, si id oppidum retinuissent, summam victoriae constare intellegebant.

22. Singulari militum nostrorum virtuti consilia cujusquemodi Gallorum occurrebant, ut est summae genus sollertiae, atque ad omnia imitanda et efficienda quae ab quoque traduntur aptissimum. <sup>2</sup>Nam et laqueis falces avertebant, quas, cum destinaverant, tormentis introrsus reducebant; et aggerem cuniculis subtrahebant, eo scientius quod apud eos magna sunt ferrariae, atque omne genus cuniculorum notum atque usitatum est. <sup>3</sup>Totum autem murum ex omni parte turribus contabulaverant, atque has coriis intexerant. <sup>4</sup>Tum crebris diurnis nocturnisque eruptionibus aut aggeri ignem inferebant, aut milites occupatos in opere adoriebantur; et nostrarum turrium altitudinem, quantum has cotidianus agger expresserat, commissis suarum turrium malis adaequabant; <sup>5</sup>et apertos cuniculos praeusta et praeacuta materia, et

pice fervefacta, et maximi ponderis saxis morabantur, moenibusque appropinquare prohibebant.

23. Muri autem omnes Gallici hac fere forma sunt. Trabes directae perpetuae in longitudinem, paribus intervallis, distantes inter se binos pedes, in solo collo- 5 cantur: hae revinciuntur introrsus, et multo aggere vestiuntur: ea autem quae diximus intervalla grandibus in fronte saxis effarciuntur. <sup>2</sup> His collocatis et coagmentatis, alius insuper ordo additur, ut idem illud intervallum servetur, neque inter se contingant trabes, sed 10 paribus intermissae spatiis, singulae singulis saxis interjectis, arcte contineantur. Sic deinceps omne opus contexitur, dum justa muri altitudo expleatur. <sup>3</sup> Hoc cum in speciem varietatemque opus deforme non est, alternis trabibus ac saxis, quae rectis lineis suos ordines 15 servant: tum ad utilitatem et defensionem urbium summam habet opportunitatem; quod et ab incendio lapis, et ab ariete materia defendit, quae, perpetuis trabibus pedes quadragenos plerumque introrsus revincta, neque perrumpi neque distrahi potest. 20

24. His tot rebus impedita oppugnatione, milites, cum toto tempore frigore et assiduis imbribus tardarentur, tamen continenti labore omnia haec superaverunt, et diebus xxv, aggerem latum pedes cccxxx, altum pedes LXXX, exstruxerunt. <sup>2</sup> Cum is murum hostium paene 25 contingeret, et Caesar ad opus consuetudine excubaret, militesque hortaretur ne quod omnino tempus ab opere intermitteretur, — paulo ante tertiam vigiliam est animadversum fumare aggerem, quem cuniculo hostes succenderant; eodemque tempore toto muro clamore 30 sublato, duabus portis ab utroque latere turrium eruptio fiebat. <sup>3</sup> Alii faces atque aridam materiem de muro in aggerem eminus jaciebant; picem reliquasque res quibus ignis excitari potest fundebant; ut, quo primum curreretur, aut cui rei ferretur auxilium, vix ratio iniri 35 posset. <sup>4</sup> Tamen, quod instituto Caesaris semper duae

legiones pro castris excubabant, pluresque partitis temporibus erant in opere, celeriter factum est, ut alii eruptionibus resisterent, alii tures reducerent, aggeremque interscinderent, omnis vero ex castris multitudo ad  
5 restinguendum concurreret.

25. Cum in omnibus locis, consumpta jam reliqua parte noctis, pugnaretur, semperque hostibus spes victoriae redintegraretur, — eo magis, quod deustos pluteos turrium videbant, nec facile adire apertos ad auxiliandum animadvertabant, — semperque ipsi recentes defessis succederent, omnemque Galliae salutem in illo vestigio temporis positam arbitrarentur; accidit, inspectantibus nobis, quod dignum memoria visum praetereundum non existimavimus. <sup>2</sup> Quidam ante portam oppidi Gallus  
10 per manus sevi ac picis traditas glebas in ignem e regione turris proiciebat; scorpione ab latere dextro trajectus exanimatusque concidit. <sup>3</sup> Hunc ex proximis unus jacentem transgressus eodem illo munere fungebatur: eadem ratione ictu scorpionis exanimato alteri  
20 successit tertius, et tertio quartus; nec prius ille est a propugnatoribus vacuus relictus locus, quam, restincto aggere atque omni parte submotis hostibus, finis est pugnandi factus.

26. Omnia experti Galli, quod res nulla successerat,   
25 postero die consilium ceperunt ex oppido profugere, hortante et jubente Vercingetorige. <sup>2</sup> Id silentio noctis conati, non magna jactura suorum sese effecturos sperabant; propterea quod neque longe ab oppido castra Vercingetorigis aberant, et palus, quae perpetua intercedebat, Romanos ad insequendum tardabat. <sup>3</sup> Jamque  
30 hoc facere noctu apparabant, cum matresfamiliae repente in publicum procurrerunt, flentesque, projectae ad pedes suorum, omnibus precibus petierunt, ne se et communes liberos hostibus ad supplicium dederent, quos  
35 ad capiendam fugam naturae et virium infirmitas impediret. <sup>4</sup> Ubi eos in sententia perstare viderunt, quod

plerumque in summo periculo timor misericordiam non recipit, conclamare et significare de fuga Romanis coeperunt. <sup>5</sup> Quo timore perterriti Galli, ne ab equitatu Romanorum viae praeoccuparentur, consilio destiterunt.

27. Postero die Caesar, promotae turri directisque operibus quae facere instituerat, magno coörto imbore, non inutilem hanc ad capiendum consilium tempestatem arbitratus est, quod paulo incautius custodias in muro dispositas videbat, suosque languidius in opere versari iussit, et quid fieri vellet ostendit. <sup>2</sup> Legionibusque intra vineas in occulto expeditis, cohortatus ut aliquando pro tantis laboribus fructum victoriae perciperent, iis qui primi murum adscendissent praemia proposuit, militibusque signum dedit. <sup>3</sup> Illi subito ex omnibus partibus evolaverunt, murumque celeriter compleverunt. 15

28. Hostes re nova perterriti, muro turribusque dejecti, in foro ac locis patentioribus cuneatim constiterunt, hoc animo ut, si qua ex parte obviam contra veniretur, acie instructa depugnarent. <sup>2</sup> Ubi neminem in aequum locum sese demittere, sed toto undique muro circumfundi viderunt, veriti ne omnino spes fugae tolleretur, abjectis armis, ultimas oppidi partes continenti impetu petiverunt; parsque ibi, cum angusto portarum exitu se ipsi premerent, a militibus, pars jam egressa portis ab equitibus, est interfecta: nec fuit quisquam qui praedae studeret. <sup>3</sup> Sic et Genabi caede et labore operis incitati, non aetate confectis, non mulieribus, non infantibus pepercerunt: denique ex omni numero, qui fuit circiter milium XL, vix DCCC, qui primo clamore audito se ex oppido ejecerunt, incolumes ad Vercingetorigem pervenerunt. <sup>4</sup> Quos ille multa jam nocte silentio ex fuga excepit, veritus ne qua in castris eorum concursu et misericordia volgi seditio oreretur, ut, procul in via dispositis familiaribus suis principibusque civitatum, disparandos deducendosque ad suos curaret, quae cuique civitati pars castrorum ab initio obvenerat. 35

29. Postero die concilio convocato, consolatus cohortatusque est: 'Ne se admodum animo demitterent, ne perturbarentur incommodo; <sup>2</sup> non virtute neque in acie vicisse Romanos, sed artificio quodam et scientia oppugnationis, cujus rei fuerint ipsi imperiti; errare, si qui in bello omnes secundos rerum proventus expectent; <sup>3</sup> sibi nunquam placuisse Avaricum defendi, cujus rei testes ipsos haberet, sed factum imprudentia Biturigum et nimia obsequentia reliquorum, uti hoc incommodum acciperetur; id tamen se celeriter majoribus commodis sanaturum. <sup>4</sup> Nam, quae ab reliquis Gallis civitates dissentirent, has sua diligentia adjuncturum atque unum consilium totius Galliae effecturum, cujus consensui ne orbis quidem terrarum possit obsistere; <sup>5</sup> idque se prope jam effectum habere. <sup>5</sup> Interea aequum esse, ab iis communis salutis causa impetrari, ut castra munire instituerent, quo facilius repentinos hostium impetus sustinerent.'

30. Fuit haec oratio non ingrata Gallis, et maxime quod ipse animo non defecerat tanto accepto incommodo, neque se in occultum abdiderat et conspectum multitudinis fugerat; plusque animo providere et praesentire existimabatur, quod, re integra, primo incendendum Avaricum, post deserendum censuerat. <sup>2</sup> Itaque, ut reliquorum imperatorum res adversae auctoritatem minuunt, sic hujus ex contrario dignitas, incommodo accepto, in dies augebatur. <sup>3</sup> Simul in spem veniebant ejus affirmatione de reliquis adjungendis civitatibus; primumque eo tempore Galli castra munire instituerunt, et sic sunt animo confirmati, homines insueti laboris, ut omnia quae imperarentur sibi patienda existimarent.

31. Nec minus quam est pollicitus, Vercingetorix animo laborabat ut reliquas civitates adjungeret, atque eas donis pollicitationibusque alliciebat. <sup>2</sup> Huic rei idoneos homines deligebat, quorum quisque aut oratione subdola aut amicitia facillime capere posset. Qui

Avarico expugnato refugerant, armandos vestiendosque curat. <sup>3</sup> Simul, ut deminutae copiae redintegrarentur, imperat certum numerum militum civitatibus, quem, et quam ante diem, in castra adduci velit; sagittariosque omnes, quorum erat permagnus numerus in Gallia, con- <sup>5</sup> quiri et ad se mitti jubet. <sup>4</sup> His rebus celeriter id quod Avarici deperierat expletur. Interim Teutomatus, Olloviconis filius, rex Nitiobrigum, cujus pater ab senatu nostro amicus erat appellatus, cum magno equitum suorum numero et quos ex Aquitania conduxerat ad eum <sup>10</sup> pervenit.

32. Caesar Avarici complures dies commoratus, summamque ibi copiam frumenti et reliqui commeatus nactus, exercitum ex labore atque inopia refecit. <sup>2</sup> Jam prope hieme confecta, — cum ipso anni tempore ad ge- <sup>15</sup> rendum bellum vocaretur, et ad hostem proficisci constituisset, sive eum ex paludibus silvisque elicere sive obsidione premere posset, — legati ad eum principes Haeduorum veniunt, oratum, ut maxime necessario tempore civitati subveniat: <sup>3</sup> ‘summo esse in periculo rem; <sup>20</sup> quod, cum singuli magistratus antiquitus creari atque regiam potestatem annum obtinere consuessent, duo magistratum gerant, et se uterque eorum legibus creatum esse dicat. <sup>4</sup> Horum esse alterum Convictolitavem, florentem et illustrem adolescentem; alterum Cotum, <sup>25</sup> antiquissima familia natum, atque ipsum hominem summae potentiae et magnae cognationis, cujus frater Valenticus proximo anno eundem magistratum gesserit; civitatem omnem esse in armis, divisum senatum, divisum populum, suas cujusque eorum clientelas. <sup>5</sup> Quod <sup>30</sup> si diutius alatur controversia, fore uti pars cum parte civitatis confligat; id ne accidat, positum in ejus diligentia atque auctoritate.’

33. Caesar, etsi a bello atque hoste discedere detrimentosum esse existimabat, tamen non ignorans quanta <sup>35</sup> ex dissensionibus incommoda oriri consuessent, ne tanta

et tam conjuncta populo Romano civitas, quam ipse  
semper aluisset omnibusque rebus ornasset, ad vim  
atque ad arma descenderet, atque ea pars quae minus  
confideret auxilia a Vercingetorige arcesseret, huic rei  
5 praevertendum existimavit; <sup>2</sup>et quod, legibus Haedu-  
rum, iis qui summum magistratum obtinerent excedere  
ex finibus non liceret, ne quid de jure aut de legibus  
eorum deminuisse videretur, ipse in Haeduos proficisci  
statuit, senatumque omnem et quos inter controversia  
10 esset ad se Decetiam evocavit. <sup>3</sup>Cum prope omnis civi-  
tas eo convenisset, docereturque, paucis clam convocatis,  
alio loco alio tempore atque oportuerit, fratrem a fratre  
renuntiatum, cum leges duo ex una familia, vivo utroque,  
non solum magistratus creari vetarent, sed etiam in se-  
15 natu esse prohiberent, — Cotum imperium deponere coë-  
git; Convictolitavem, qui per sacerdotes, more civitatis,  
intermissis magistratibus, esset creatus, potestatem ob-  
tinere jussit.

34. Hoc decreto interposito, — cohortatus Haeduos ut  
20 controversiarum ac dissensionis obliviscerentur, atque,  
omnibus omissis rebus, huic bello servirent, eaque quae  
meruissent praemia ab se, devicta Gallia, exspectarent,  
equitatumque omnem et peditum milia decem sibi cele-  
riter mitterent, quae in praesidiis rei frumentariae causa  
25 disponderet, — <sup>2</sup>exercitum in duas partes divisit: iv le-  
giones in Senones Parisiosque Labieno ducendas dedit;  
vi ipse in Arvernos, ad oppidum Gergoviam secundum  
flumen Elaver, duxit; equitatus partem illi attribuit,  
partem sibi reliquit. <sup>3</sup>Qua re cognita, Vercingetorix,  
30 omnibus interruptis ejus fluminis pontibus, ab altera  
fluminis parte iter facere coepit.

35. Cum uterque utrimque exisset exercitus, in con-  
spectu, fereque e regione castris, castra ponebant. Dis-  
positis exploratoribus, necubi effecto ponte Romani co-  
35 pias traducerent, erat in magnis Caesaris difficultatibus  
res, ne majorem aestatis partem flumine impediretur;



quod non fere ante autumnum Elaver vado transiri solet.  
<sup>2</sup> Itaque, ne id accideret, silvestri loco castris positus, e regione unius eorum pontium quos Vercingetorix rescindendos curaverat, postero die cum duabus legionibus in occulto restitit; reliquas copias cum omnibus impedi- 5  
 mentis, ut consueverat, misit, † captis quibusdam cohortibus, uti numerus legionum constare videretur. <sup>3</sup> His quam longissime possent progredi jussis, cum jam ex diei tempore conjecturam ceperat in castra perventum, iisdem sublicis, quarum pars inferior integra remanebat, 10  
 pontem reficere coepit. <sup>4</sup> Celeriter effecto opere legionibusque traductis et loco castris idoneo delecto, reliquas copias revocavit. Vercingetorix, re cognita, ne contra suam voluntatem dimicare cogeretur, magnis itineribus antecessit. 15

36. Caesar ex eo loco quintis castris Gergoviam pervenit, equestrique eo die proelio levi facto, perspecto urbis situ, quae posita in altissimo monte omnes aditus difficiles habebat, de expugnatione desperavit; de obsessione non prius agendum constituit, quam rem frumentariam expedisset. <sup>2</sup> At Vercingetorix, castris prope oppidum positus, mediocribus circum se intervallis separatim singularum civitatum copias collocaverat; atque, omnibus ejus jugi collibus occupatis qua despici poterat, horribilem speciem praebebat; principesque earum civi- 25  
 tatum, quos sibi ad consilium capiendum delegerat, prima luce cotidie ad se convenire jubebat, seu quid communicandum seu quid administrandum videretur; neque ullum fere diem intermittebat, quin equestri proelio, interjectis sagittariis, quid in quoque esset animi ac virtutis suorum perspiceret. <sup>3</sup> Erat e regione oppidi collis sub ipsis radicibus montis, egregie munitus atque ex omni parte circumciscus, quem si tenerent nostri, et aquae magna parte et pabulatione libera prohiberi hostes videbantur; sed is locus praesidio ab his non nimis firmo 35  
 tenebatur; <sup>4</sup> tamen silentio noctis Caesar ex castris egres-

5 sus, priusquam subsidio ex oppido veniri posset, dejecto praesidio, potitus loco, duas ibi legiones collocavit, fossamque duplicem duodenum pedum a majoribus castris ad minora perduxit, ut tuto ab repentino hostium incursu etiam singuli commeari possent.

37. Dum haec ad Gergoviam geruntur, Convictolitavis Haeduus, cui magistratum adjudicatum a Caesare demonstravimus, sollicitatus ab Arvernibus pecunia, cum quibusdam adolescentibus colloquitur, quorum erat princeps  
 10 Litavicus atque ejus fratres, amplissima familia nati adolescentes. <sup>2</sup>Cum his praemium communicat, hortaturque ut se liberos et imperio natos meminerint: <sup>3</sup>‘Unam esse Haeduum civitatem, quae certissimam Galliae victoriam detineat; ejus auctoritate reliquas  
 15 contineri; qua traducta, locum consistendi Romanis in Gallia non fore: esse nonnullo se Caesaris beneficio affectum, sic tamen ut justissimam apud eum causam obtinuerit; sed plus communi libertati tribuere. <sup>4</sup>Cur enim potius Haedui de suo jure et de legibus ad Caesarem disceptatorem, quam Romani ad Haeduos veniant?’  
 20 <sup>5</sup>Celeriter adolescentibus et oratione magistratus et praemio deductis, cum se vel principes ejus consilii fore profiterentur, ratio perficiendi quaerebatur, quod civitatem temere ad suscipiendum bellum adduci posse non  
 25 confidebant. <sup>6</sup>Placuit ut Litavicus decem illis milibus quae Caesari ad bellum mitterentur, praeficeretur, atque ea ducenda curaret, fratresque ejus ad Caesarem praecurrerent. Reliqua qua ratione agi placeat constituunt.

38. Litavicus, accepto exercitu, cum milia passuum  
 30 circiter xxx ab Gergovia abesset, convocatis subito militibus, lacrimans, “Quo proficiscimur,” inquit, “milites?”  
<sup>2</sup>Omnis noster equitatus, omnis nobilitas interiit; principes civitatis, Eporedorix et Viridomarus, insimulati prodicionis, ab Romanis indicta causa interfecti sunt.  
 35 <sup>3</sup>Haec ab ipsis cognoscite qui ex ipsa caede fugerunt; nam ego, fratribus atque omnibus meis propinquis inter-

fectis, dolore prohibeor quae gesta sunt pronuntiare.”  
<sup>4</sup> Producuntur hi quos ille edocuerat quae dici vellet, atque eadem quae Litavicus pronuntiaverat multitudini exponunt: equites Haeduum interfectos, quod collo-  
 cuti cum Arvernibus dicerentur; ipsos se inter multitudine 5  
 militum occultasse atque ex media caede fugisse.  
<sup>5</sup> Conclamant Haedui, et Litavicum obsecrant ut sibi consulat. “Quasi vero,” inquit ille, “consilii sit res, ac non necesse sit nobis Gergoviam contendere et cum Arvernibus nosmet conjungere!”  
<sup>6</sup> An dubitamus quin, 10  
 nefario facinore admissio, Romani jam ad nos interficiendos concurrant? Proinde, si quid in nobis animi est, persequamur eorum mortem qui indignissime interierunt, atque hos latrones interficiamus!”  
<sup>7</sup> Ostendit cives Romanos, qui ejus praesidii fiducia una erant; magnum 15  
 numerum frumenti commeatusque diripit; ipsos crudeliter excruciatos interficit.  
<sup>8</sup> Nuntios tota civitate Haeduum dimittit: eodem mendacio de caede equitum et principum permovet; hortatur, ut simili ratione atque ipse fecerit suas injurias persequantur. 20

39. Eporedorix Haeduum, summo loco natus adolescens et summae domi potentiae, et una Viridomarus, pari aetate et gratia sed genere dispari, quem Caesar ab Divitiaco sibi traditum ex humili loco ad summam dignitatem perduxerat, in equitum numero convenerant, 25  
 nominatim ab eo evocati.  
<sup>2</sup> His erat inter se de principatu contentio; et in illa magistratum controversia, alter pro Convictolitavi, alter pro Coto, summis opibus pugnauerant.  
<sup>3</sup> Ex iis Eporedorix, cognito Litavici consilio, media fere nocte rem ad Caesarem defert; orat, ne 30  
 patiat civitatem pravis adolescentium consiliis ab amicitia populi Romani deficere; <sup>4</sup> quod futurum provideat, si se tot hominum milia cum hostibus junxerint, quorum salutem neque propinqui negligere neque civitas levi momento aestimare posset. 35

40. Magna affectus sollicitudine hoc nuntio Caesar,

quod semper Haeduorum civitati praecipue indulserat, nulla interposita dubitatione, legiones expeditas quatuor equitatumque omnem ex castris educit; <sup>2</sup> nec fuit spatium tali tempore ad contrahenda castra, quod res  
 5 posita in celeritate videbatur. <sup>3</sup> C. Fabium legatum cum legionibus duabus castris praesidio relinquit. Fratres Litavici cum comprehendi jussisset, paulo ante reperit ad hostes fugisse. <sup>4</sup> Adhortatus milites ne necessario tempore itineris labore permoveantur, cupidissimis  
 10 omnibus, progressus milia passuum xxv, agmen Haeduum conspicatus, immisso equitatu, iter eorum moratur atque impedit; interdicique omnibus ne quemquam interficiant. <sup>5</sup> Eporedorigem et Viridomarum, quos illi interfectos existimabant, inter equites versari suosque  
 15 appellare jubet. <sup>6</sup> His cognitis, et Litavici fraude perspecta, Haedui manus tendere, deditionem significare, et projectis armis mortem deprecari incipiunt. <sup>7</sup> Litavicus cum suis clientibus, quibus more Gallorum nefas est etiam in extrema fortuna deserere patronos, Gergoviam  
 20 profugit.

41. Caesar, nuntiis ad civitatem Haeduorum missis, qui suo beneficio conservatos docerent quos jure belli interficere potuisset, tribusque horis noctis exercitui ad quietem datis, castra ad Gergoviam movit. <sup>2</sup> Medio  
 25 fere itinere, equites ab Fabio missi quanto res in periculo fuerit exponunt: summis copiis castra oppugnata demonstrant, cum crebro integri defessis succederent, nostrosque assiduo labore defatigarent, quibus propter magnitudinem castrorum perpetuo esset isdem in vallo  
 30 permanendum; <sup>3</sup> multitudine sagittarum atque omnis generis telorum multos vulneratos; ad haec sustinenda magno usui fuisse tormenta; <sup>4</sup> Fabium discessu eorum, duabus relictis portis, obstruere ceteras, pluteosque vallo addere, et se in posterum diem similemque casum appa-  
 35 rare. <sup>5</sup> His rebus cognitis, Caesar summo studio militum ante ortum solis in castra pervenit.

42. Dum haec ad Gergoviam geruntur, Haedui primis nuntiis ab Litavico acceptis, nullum sibi ad cognoscendum spatium relinquunt. <sup>2</sup> Impellit alios avaritia, alios iracundia et temeritas, quae maxime illi hominum generi est innata, ut levem auditionem habeant pro re comperta : 5 bona civium Romanorum diripiunt, caedes faciunt, in servitutem abstrahunt. <sup>3</sup> Adjuvat rem proclinatam Convictolitavis, plebemque ad furorem impellit, ut, facinore admissio, ad sanitatem reverti pudeat. <sup>4</sup> M. Aristium, tribunum militum, iter ad legionem facientem, fide data, 10 ex oppido Cabillono educunt ; idem facere cogunt eos qui negotiandi causa ibi constiterant. <sup>5</sup> Hos continuo in itinere adorti omnibus impedimentis exuunt ; repugnantes diem noctemque obsident ; multis utrimque interfectis, majorem multitudinem ad arma concitant. 15

43. Interim, nuntio allato omnes eorum milites in potestate Caesaris teneri, concurrunt ad Aristium ; nihil publico factum consilio demonstrant ; quaestionem de bonis direptis decernunt ; Litavici fratrumque bona publicant ; legatos ad Caesarem sui purgandi gratia mittunt. 20 <sup>2</sup> Haec faciunt recuperandorum suorum causa ; sed contaminati facinore et capti compendio ex direptis bonis, quod ea res ad multos pertinebat, timore poenae exteriti, consilia clam de bello inire incipiunt, civitatesque reliquas legationibus sollicitant. <sup>3</sup> Quae tametsi Caesar 25 intellegebat, tamen quam mitissime potest legatos appellat : nihil se propter inscientiam levitatemque vulgi gravius de civitate judicare, neque de sua in Haeduos benevolentia deminuere. <sup>4</sup> Ipse majorem Galliae motum exspectans, ne ab omnibus civitatibus circumstingeretur, 30 consilia inibat, quemadmodum ab Gergovia discederet ac rursus omnem exercitum contraheret ; ne profectio nata ab timore defectionis similis fugae videretur.

44. Haec cogitanti accidere visa est facultas bene gerendae rei. Nam cum in minora castra operis perspi- 35 ciendi causa venisset, animadvertit collem, qui ab hosti-

bus tenebatur, nudatum hominibus, qui superioribus diebus vix prae multitudine cerni poterat. <sup>2</sup>Admiratus quaerit ex perfugis causam, quorum magnus ad eum cotidie numerus confluebat. Constabat inter omnes,   
 5 quod jam ipse Caesar per exploratores cognoverat, dorsum esse ejus jugi prope aequum, sed hunc silvestrem et angustum, qua esset aditus ad alteram partem oppidi: <sup>3</sup>vehementer huic illos loco timere, nec jam aliter sentire, uno colle ab Romanis occupato, si alterum amis-   
 10 sent, quin paene circumvallati atque omni exitu et pabulatione interclusi viderentur; ad hunc muniendum omnes a Vercingetorige evocatos.

45. Hac re cognita, Caesar mittit complures equitum turmas: eis de media nocte imperat, ut paulo tumultu-   
 15 osius omnibus locis vagarentur. <sup>2</sup>Prima luce magnum numerum impedimentorum ex castris mulorumque produci, deque his stramenta detrahi, mulionesque cum cassidibus, equitum specie ac simulatione, collibus circumvehi jubet. <sup>3</sup>His paucos addit equites, qui latius   
 20 ostentationis causa vagarentur. Longo circuitu easdem omnes jubet petere regiones. <sup>4</sup>Haec procul ex oppido videbantur, ut erat a Gergovia despectus in castra; neque, tanto spatio, certi quid esset explorari poterat. <sup>5</sup>Legionem unam eodem jugo mittit, et paulum progres-   
 25 sam inferiore constituit loco, silvisque occultat. Auge- tur Gallis suspicio, atque omnes illo munitionum copiae traducuntur. <sup>6</sup>Vacua castra hostium Caesar conspicatus, tectis insignibus suorum, occultatisque sig-   
 30 nerentur) ex majoribus castris in minora traducit, legatisque, quos singulis legionibus praefecerat, quid fieri velit ostendit: <sup>7</sup>imprimis monet, ut contineant milites, ne studio pugnandi aut spe praedae longius progrediantur; quid iniquitas loci habeat incommodi   
 35 proponit; hoc una celeritate posse mutari; occasionis esse rem, non proelii. <sup>8</sup>His rebus expositis, signum dat,

et ab dextra parte alio adscensu eodem tempore Haeduos mittit.

46. Oppidi murus ab planicie, atque initio adscensus recta regione, si nullus amfractus intercederet, MCC passus aberat; quidquid huc circuitus ad molliendum cli- 5  
vum accesserat, id spatium itineris augebat. <sup>2</sup> At medio fere colle in longitudinem, ut natura montis ferebat, ex grandibus saxis sex pedum murum, qui nostrorum impetum tardaret, praeduxerant Galli; atque, inferiore omni spatio vacuo relicto, superiorem partem collis 10  
usque ad murum oppidi densissimis castris compleverant. <sup>3</sup> Milites, dato signo, celeriter ad munitionem perveniunt, eamque transgressi trinis castris potiuntur. <sup>4</sup> Ac tanta fuit in castris capiendis celeritas, ut Teutomatus, rex Nitiobrigum, subito in tabernaculo oppressus, 15  
ut meridie conquieverat, superiore corporis parte nudata, vulnerato equo, vix se ex manibus praedantium militum eriperet.

47. Consecutus id quod animo proposuerat, Caesar receptui cani jussit, legionique decimae, quacum erat, 20  
contionatus, signa constituit. <sup>2</sup> At reliquarum legionum milites, non exaudito sono tubae, quod satis magna valles intercedebat, tamen ab tribunis militum legatisque, ut erat a Caesare praeceptum, retinebantur. <sup>3</sup> Sed elati spe celeris victoriae et hostium fuga et superiorum tempo- 25  
rum secundis proeliis, nihil adeo arduum sibi esse existimaverunt quod non virtute consequi possent; neque finem prius sequendi fecerunt quam muro oppidi portisque appropinquarent. <sup>4</sup> Tum vero ex omnibus urbis partibus orto clamore, qui longius aberant, repentino 30  
tumultu perterriti, cum hostem intra portas esse existimarent, sese ex oppido ejecerunt. <sup>5</sup> Matresfamiliae de muro vestem argentumque jactabant; et, pectore nudo prominentes, passis manibus obtestabantur Romanos, ut sibi parcerent; neu, sicut Avarici fecissent, ne a mulie- 35  
ribus quidem atque infantibus abstinerent. <sup>6</sup> Nonnullae,

de muris per manus demissae, sese militibus tradebant. L. Fabius, centurio legionis octavae, quem inter suos eo die dixisse constabat, excitari se Avaricensibus praemiis, neque commissurum, ut prius quisquam murum  
5 adscenderet, tres suos nactus manipulares, atque ab iis sublevatus, murum adscendit. Hos ipse rursus, singulos exceptans, in murum extulit.

48. Interim ii qui ad alteram partem oppidi, ut supra demonstravimus, munitionis causa convenerant, primo  
10 exaudito clamore, inde etiam crebris nuntiis incitati, oppidum ab Romanis teneri, praemissis equitibus, magno concursu eo contenderunt. <sup>2</sup>Eorum ut quisque primus venerat, sub muro consistebat, suorumque pugnantium numerum augebat. Quorum cum magna multitudo con-  
15 venisset, matresfamiliae, quae paulo ante Romanis de muro manus tendebant, suos obtestari, et more Gallico passum capillum ostentare, liberosque in conspectum proferre coeperunt. <sup>3</sup>Erat Romanis nec loco nec numero aequa contentio: simul et cursu et spatio pugnae  
20 defatigati, non facile recentes atque integros sustinebant.

49. Caesar cum iniquo loco pugnari hostiumque augeri copias videret, praemetuens suis, ad T. Sextium legatum, quem minoribus castris praesidio reliquerat, misit,  
25 ut cohortes ex castris celeriter educeret, et sub infimo colle ab dextro latere hostium constitueret; <sup>2</sup>ut, si nostros loco depulsos vidisset, quo minus libere hostes insequerentur terreret. Ipse, paulum ex eo loco cum legione progressus ubi constiterat, eventum pugnae ex-  
30 spectabat.

50. Cum acerrime comminus pugnaretur, hostes loco et numero, nostri virtute confiderent, subito sunt Haedui visi, ab latere nostris aperto, quos Caesar ab dextra parte alio adscensu manus destinandae causa miserat.  
35 <sup>2</sup>Hi similitudine armorum vehementer nostros perterruerunt; ac, tametsi dextris humeris exsertis animadver-



tebantur, quod insigne pacatum esse consuerat, tamen id ipsum sui fallendi causa milites ab hostibus factum existimabant. <sup>3</sup> Eodem tempore L. Fabius centurio, quique una murum adscenderant, circumventi atque interfecti, muro praecipitabantur. <sup>4</sup> M. Petronius, ejusdem legionis centurio, cum portas excidere conatus esset, a multitudine oppressus ac sibi desperans, multis jam vulneribus acceptis, manipularibus suis qui illum secuti erant, "Quoniam," inquit, "me una vobiscum servare non possum, vestrae quidem certe vitae prospiciam, quos cupiditate gloriae adductus in periculum deduxi. Vos, data facultate, vobis consulite." <sup>5</sup> Simul in medios hostes irrupit, duobusque interfectis, reliquos a porta paulum submovit. Conantibus auxiliari suis, "Frustra," inquit, "meae vitae subvenire conamini, quem jam sanguis viresque deficiunt. <sup>6</sup> Proinde abite dum est facultas, vosque ad legionem recipite." Ita pugnans post paulum concidit, ac suis saluti fuit.

51. Nostri, cum undique premerentur, quadraginta sex centurionibus amissis, dejecti sunt loco; sed intolerantius Gallos insequentes legio decima tardavit, quae pro subsidio paulo aequiore loco constiterat. <sup>2</sup> Hanc rursus decimae tertiae legionis cohortes exceperunt, quae, ex castris minoribus eductae, cum T. Sextio legato ceperant locum superiorem. <sup>3</sup> Legiones ubi primum planitiem attigerunt, infestis contra hostes signis constiterunt. Vercingetorix ab radicibus collis suos intra munitiones reduxit. Eo die milites sunt paulo minus septingenti desiderati.

52. Postero die Caesar, contione advocata, temeritatem cupiditatemque militum reprehendit, quod sibi ipsi judicavissent quo procedendum aut quid agendum videretur, neque, signo recipiendi dato, constitissent, neque ab tribunis militum legatisque retineri potuissent. <sup>2</sup> Exposuit quid iniquitas loci posset, quod ipse ad Avaricum sensisset, cum sine duce et sine equitatu deprehensis

hostibus exploratam victoriam dimisisset, ne parvum modo detrimentum in contentione propter iniquitatem loci accideret. <sup>3</sup>Quanto opere eorum animi magnitudinem admiraretur, quos non castrorum munitiones, non  
 5 altitudo montis, non murus oppidi tardare potuisset: tanto opere licentiam arrogantiamque reprehendere, quod plus se quam imperatorem de victoria atque exitu rerum sentire existimarent: nec minus se ab milite modestiam et continentiam quam virtutem atque animi  
 10 magnitudinem desiderare.

53. Hac habita contione, et ad extremam orationem confirmatis militibus, ne ob hanc causam animo permoverentur, neu, quod iniquitas loci attulisset, id virtuti hostium tribuerent; eadem de profectio cogitans quae  
 15 ante senserat, legiones ex castris eduxit, aciemque idoneo loco constituit. <sup>2</sup>Cum Vercingetorix nihilo magis in aequum locum descenderet, levi facto equestri proelio atque secundo, in castra exercitum reduxit. <sup>3</sup>Cum hoc idem postero die fecisset, satis ad Gallicam ostentationem minuendam militumque animos confirmandos  
 20 factum existimans, in Haeduos movit castra. Ne tum quidem insecutis hostibus, tertio die ad flumen Elaver pontes reficit, atque exercitum traducit.

54. Ibi a Viridomaro atque Eporedorige Haeduis ap-  
 25 pellatus, discit, cum omni equitatu Litavicum ad sollicitandos Haeduos profectum; opus esse ipsos antecedere ad confirmandam civitatem. <sup>2</sup>Etsi multis jam rebus perfidiam Haeduorum perspectam habebat, atque horum discessu admaturari defectionem civitatis existimabat;  
 30 tamen eos retinendos non constituit, ne aut inferre injuriam videretur, aut dare timoris aliquam suspicionem. <sup>3</sup>Discedentibus his breviter sua in Haeduos merita exposuit; quos et quam humiles accepisset, compulsos in oppida, multatos agris, omnibus ereptis copiis, imposito  
 35 stipendio, obsidibus summa cum contumelia extortis;  
<sup>4</sup>et quam in fortunam quamque in amplitudinem de-

duxisset, ut non solum in pristinum statum redissent, sed omnium temporum dignitatem et gratiam antecessisse viderentur. His datis mandatis, eos ab se dimisit.

55. Noviodunum erat oppidum Haeduorum, ad ripas Ligeris opportuno loco positum. Huc Caesar omnes 5 obsides Galliae, frumentum, pecuniam publicam, suorum atque exercitus impedimentorum magnam partem contulerat; huc magnum numerum equorum, hujus belli causa in Italia atque Hispania coemptum, miserat. <sup>2</sup>Eo cum Eporedorix Viridomarusque venissent, et 10 de statu civitatis cognovissent, Litavicum Bibracti ab Haeduis receptum, quod est oppidum apud eos maximae auctoritatis, Convictolitavim magistratum magnamque partem senatus ad eum convenisse, legatos ad Vercingetorigem de pace et amicitia concilianda publice missos; 15 non praetermittendum tantum commodum existimaverunt. <sup>3</sup>Itaque, interfectis Novioduni custodibus, quique eo negotiandi causa convenerant, pecuniam atque equos inter se partiti sunt; obsides civitatum Bibracte ad magistratum deducendos curaverunt; oppidum, quod a se 20 teneri non posse judicabant, ne quoi esset usui Romanis, incenderunt; <sup>4</sup>frumenti quod subito potuerunt navibus avexerunt, reliquum flumine atque incendio corruperunt; ipsi ex finitimis regionibus copias cogere, praesidia custodiasque ad ripas Ligeris disponere, 25 equitatumque omnibus locis iniciendi timoris causa ostentare coeperunt; si ab re frumentaria Romanos excludere aut adductos inopia in Provinciam expellere possent. <sup>5</sup>Quam ad spem multum eos adjuvabat, quod Liger ex nivibus creverat, ut omnino vado non posse 30 transiri videretur.

56. Quibus rebus cognitis, Caesar maturandum sibi censuit, si esset in perficiendis pontibus periclitandum; ut, prius quam essent majores eo coactae copiae, dimicaret. <sup>2</sup>Nam ne commutato consilio iter in Provinciam 35 converteret, ut nemo non tum quidem necessario faci-

endum existimabat, cum infamia atque indignitas rei et oppositus mons Cevenna viarumque difficultas impedi-  
 bat; tum maxime, quod abjuncto Labieno atque iis  
 legionibus quas una miserat, vehementer timebat.  
 5<sup>3</sup> Itaque, admodum magnis diurnis atque nocturnis ite-  
 neribus confectis, contra omnium opinionem ad Ligerim  
 venit; vadoque per equites invento, pro rei necessitate,  
 opportuno, ut brachia modo, atque humeri ad sustinenda  
 arma liberi ab aqua esse possent, disposito equitatu,  
 10 qui vim fluminis refringeret, atque hostibus primo ad-  
 spectu perturbatis, incolumem exercitum traduxit; fru-  
 mentumque in agris et pecoris copiam nactus, repleto  
 his rebus exercitu, iter in Senones facere instituit.

57. Dum haec apud Caesarem geruntur, Labienus, eo  
 15 supplemento quod nuper ex Italia venerat relicto Age-  
 dici, ut esset impedimentis praesidio, cum quattuor  
 legionibus Lutetiam proficiscitur: id est oppidum Pari-  
 siorum, quod positum est in insula fluminis Sequanae.  
 2 Cujus adventu ab hostibus cognito, magnae ex finitimis  
 20 civitatibus copiae convenerunt. Summa imperii tradi-  
 tur Camulogeno Aulerco, qui prope confectus aetate  
 tamen propter singularem scientiam rei militaris ad eum  
 est honorem evocatus. 3 Is cum animadvertisset per-  
 petuam esse paludem quae influeret in Sequanam, atque  
 25 illum omnem locum magnopere impediret, hic consedit,  
 nostrosque transitu prohibere instituit.

58. Labienus primo vineas agere, cratibus atque ag-  
 gere paludem explere, atque iter munire conabatur.  
 Postquam id difficiliter confieri animadvertit, silentio e  
 30 castris tertia vigilia egressus, eodem quo venerat itinere  
 Melodunum pervenit. 2 Id est oppidum Senonum in  
 insula Sequanae positum, ut paulo ante de Lutetia  
 diximus. 3 Deprehensis navibus circiter quinquaginta  
 celeriterque conjunctis, atque eo militibus injectis, et  
 35 rei novitate perterritis oppidanis, quorum magna pars  
 erat ad bellum evocata, sine contentione oppido potitur.

<sup>4</sup> Refecto ponte, quem superioribus diebus hostes resciderant, exercitum traducit, et secundo flumine ad Lutetiam iter facere coepit. <sup>5</sup> Hostes, re cognita ab iis qui a Meloduno fugerant, Lutetiam incendi, pontesque ejus oppidi rescindi jubent; ipsi, projecta palude, <sup>5</sup> ad ripas Sequanae, e regione Lutetiae, contra Labieni castra considunt.

59. Jam Caesar a Gergovia discessisse audiebatur; jam de Haeduum defectione et secundo Galliae motu rumores afferebantur; Gallique in conloquiis, inter- <sup>10</sup> clusum itinere et Ligeri Caesarem, inopia frumenti coactum, in Provinciam contendisse, confirmabant. <sup>2</sup> Bellovacii autem, defectione Haeduum cognita, qui ante erant per se infideles, manus cogere atque aperte bellum parare coeperunt. <sup>3</sup> Tum Labienus, tanta rerum <sup>15</sup> commutatione, longe aliud sibi capiendum consilium atque antea senserat intellegebat; neque jam ut aliquid acquireret proelioque hostes lacesseret, sed ut incolumem exercitum Agedicum reduceret, cogitabat. <sup>4</sup> Namque altera ex parte Bellovacii, quae civitas in Gallia <sup>20</sup> maximam habet opinionem virtutis, instabant; alteram Camulogenus parato atque instructo exercitu tenebat; tum legiones a praesidio atque impedimentis interclusas maximum flumen distinebat. Tantis subito difficultatibus objectis, ab animi virtute auxilium petendum vide- <sup>25</sup> bat.

60. Sub vesperum consilio convocato, cohortatus ut ea quae imperasset diligenter industrieque administrarent, naves quas a Meloduno deduxerat singulas equitibus Romanis attribuit; et, prima confecta vigilia, <sup>30</sup> IV milia passuum secundo flumine silentio progredi, ibique se exspectari jubet. <sup>2</sup> Quinque cohortes, quas minime firmas ad dimicandum esse existimabat, castris praesidio relinquit; quinque ejusdem legionis reliquas de media nocte cum omnibus impedimentis adverso flumine magno <sup>35</sup> tumultu proficisci imperat. <sup>3</sup> Conquirat etiam lintres;

has magno sonitu remorum incitatas in eandem partem mittit. Ipse post paulo, silentio egressus cum tribus legionibus, eum locum petit quo naves appelli jusserat.

61. Eo cum esset ventum, exploratores hostium, ut  
5 omni fluminis parte erant dispositi, inopinantes, quod magna subito erat coërta tempestas, ab nostris opprimuntur; exercitus equitatusque, equitibus Romanis administrantibus quos ei negotio praefererat, celeriter transmittitur. <sup>2</sup> Uno fere tempore sub lucem hostibus  
10 nuntiatur in castris Romanorum praeter consuetudinem tumultuari, et magnum ire agmen adverso flumine, sonitumque remorum in eadem parte exaudiri, et paulo infra milites navibus transportari. <sup>3</sup> Quibus rebus auditis, quod existimabant tribus locis transire legiones, atque  
15 omnes perturbatos defectione Haeduum fugam parare, suas quoque copias in tres partes distribuerunt. <sup>4</sup> Nam, praesidio e regione castrorum relicto, et parva manu Melodunum versus missa, quae tantum progrediatur quantum naves processissent, reliquas copias contra  
20 Labienum duxerunt.

62. Prima luce et nostri omnes erant transportati, et hostium acies cernebatur. <sup>2</sup> Labienus, milites cohortatus ut suae pristinae virtutis et secundissimorum proeliorum retinerent memoriam, atque ipsum Caesarem,  
25 cujus ductu saepenumero hostes superassent, praesentem adesse existimarent, dat signum proelii. <sup>3</sup> Primo concursu, ab dextro cornu, ubi septima legio constiterat, hostes pelluntur atque in fugam coniciuntur; ab sinistro, quem locum duodecima legio tenebat, cum primi ordines  
30 hostium transfixi pilis concidissent, tamen acerrime reliqui resistebant, nec dabat suspicionem fugae quisquam. <sup>4</sup> Ipse dux hostium Camulogenus suis aderat, atque eos cohortabatur. Incerto nunc etiam exitu victoriae, cum septimae legionis tribunis esset nuntiatum quae in si-  
35 nistro cornu gererentur, post tergum hostium legionem ostenderunt, signaque intulerunt. <sup>5</sup> Ne eo quidem tem-

pore quisquam loco cessit, sed circumventi omnes interfectique sunt. Eandem fortunam tulit Camulogenus. <sup>6</sup>At ii qui praesidio contra castra Labieni erant relictī, cum proelium commissum audissent, subsidio suis ierunt, collemque ceperunt, neque nostrorum militum victorum <sup>5</sup> impetum sustinere potuerunt. <sup>7</sup>Sic, cum suis fugientibus permixti, quos non silvae montesque texerunt, ab equitatu sunt interfecti. <sup>8</sup>Hoc negotio confecto, Labienus revertitur Agedicum, ubi impedimenta totius exercitus relictā erant. Inde cum omnibus copiis ad <sup>10</sup> Caesarem pervenit.

63. Defectione Haeduorum cognita, bellum augetur. Legationes in omnes partes circummittuntur; quantum gratia, auctoritate, pecunia valent, ad sollicitandas civitates nituntur. <sup>2</sup>Nactī obsides, quos Caesar apud eos <sup>15</sup> deposuerat, horum supplicio dubitantes territant. Petunt a Vercingetorige Haedui, ut ad se veniat rationesque belli gerundi communicet. <sup>3</sup>Re impetrata, contendunt ut ipsis summa imperii tradatur; et, re in controversiam deducta, totius Galliae concilium Bibracte <sup>20</sup> indicitur. Eodem conveniunt undique frequentes. <sup>4</sup>Multitudinis suffragiis res permittitur: ad unum omnes Vercingetorigem probant imperatorem. <sup>5</sup>Ab hoc concilio Remi, Lingones, Treveri abfuerunt: illi, quod amicitiam Romanorum sequebantur; Treveri, quod <sup>25</sup> aberant longius et ab Germanis premebantur, quae fuit causa quare toto abessent bello et neutris auxilia mitterent. <sup>6</sup>Magno dolore Haedui ferunt se dejectos principatu; queruntur fortunae commutationem, et Caesaris in se indulgentiam requirunt; neque tamen, suscepto <sup>30</sup> bello, suum consilium ab reliquis separare audent. <sup>7</sup>Inviti summae spei adulescentes, Eporedorix et Viridomarus, Vercingetorigi parent.

64. Ipse imperat reliquis civitatibus obsides; † denique ei rei constituit diem huc. Omnes equites, quindecim <sup>35</sup> milia numero, celeriter convenire jubet; <sup>2</sup>peditatu quem

ante habuerat se fore contentum dicit, neque fortunam temptaturum, aut in acie dimicaturum; sed, quoniam abundet equitatu, perfacile esse factu frumentationibus pabulationibusque Romanos prohibere: <sup>3</sup>aequo modo  
 5 animo sua ipsi frumenta corrumpant, aedificiaque incendant; qua rei familiaris jactura perpetuum imperium libertatemque se consequi videant. <sup>4</sup>His constitutis rebus, Haeduis Segusiavisque, qui sunt finitimi Provinciae, decem milia peditum imperat; huc addit equites  
 10 octingentos. His praeficit fratrem Eporedorigis, bellumque inferri Allobrogibus jubet. <sup>5</sup>Altera ex parte, Gabalos proximosque pagos Arvernorum in Helvios, item Rutenos Cadurcosque ad fines Volcarum Arecomi-  
 15 nuntiis legationibusque Allobrogas sollicitat, quorum mentes nondum ab superiore bello resedissee sperabat. Horum principibus pecunias, civitati autem imperium totius provinciae pollicetur.

65. Ad hos omnes casus provisae erant praesidia co-  
 20 hortium duarum et viginti, quae ex ipsa Provincia ab L. Caesare legato ad omnes partes opponebantur. <sup>2</sup>Helvii sua sponte cum finitimis proelio congressi pelluntur, et, C. Valerio Donnotauro, Caburi filio, principe civitatis, compluribusque aliis interfectis, intra oppida ac  
 25 muros compelluntur. <sup>3</sup>Allobroges, crebris ad Rhodanum dispositis praesidiis, magna cum cura et diligentia suos fines tuentur. <sup>4</sup>Caesar, quod hostes equitatu superiores esse intellegebat, et, interclusis omnibus itineribus, nulla re ex Provincia atque Italia sublevari  
 30 poterat, trans Rhenum in Germaniam mittit ad eas civitates quas superioribus annis pacaverat; equitesque ab his arcessit, et levis armaturae pedites, qui inter eos procliari consueverant. <sup>5</sup>Eorum adventu, quod minus idoneis equis utebantur, a tribunis militum reliquisque  
 35 [sed et] equitibus Romanis atque evocatis equos sumit, Germanisque distribuit.



66. Interea, dum haec geruntur, hostium copiae ex Arvernīs, equitesque qui toti Galliae erant imperati, conveniunt. <sup>2</sup> Magno horum coacto numero, cum Caesar in Sequanos per extremos Lingonum fines iter faceret, quo facilius subsidium Provinciae ferri posset, circiter 5 milia passuum decem ab Romanis trinis castris Vercingetorix consedit; convocatisque ad consilium praefectis equitum, venisse tempus victoriae demonstrat: <sup>3</sup> 'fugere in Provinciam Romanos, Galliaque excedere; id sibi ad praesentem obtinendam libertatem satis esse; ad reliqui 10 temporis pacem atque otium parum profici; majoribus enim coactis copiis reversuros, neque finem bellandi facturos. <sup>4</sup> Proinde in agmine impeditos adorirentur. Si pedites suis auxilium ferant, atque in eo morentur, iter facere non posse; si, id quod magis futurum confidat, 15 relictis impedimentis, suae salutis consulant, et usu rerum necessariarum et dignitate spoliatum iri. <sup>5</sup> Nam de equitibus hostium, quin nemo eorum progredi modo extra agmen audeat, et ipsos quidem non debere dubitare; et quo majore faciant animo, copias se omnes 20 pro castris habiturum, et terrori hostibus futurum.' <sup>6</sup> Conclamant equites, 'Sanctissimo jurejurando confirmari oportere, ne tecto recipiatur, ne ad liberos, ne ad parentes, ad uxorem aditum habeat, qui non bis per agmen hostium perequitasset.' 25

67. Probata re, atque omnibus jurejurando adactis, postero die in tres partes distributo equitatu, duae se acies ab duobus lateribus ostendunt, una primo agmine iter impedire coepit. <sup>2</sup> Qua re nuntiata, Caesar suum quoque equitatum, tripartito divisum, contra 30 hostem ire jubet. Pugnatur una omnibus in partibus. <sup>3</sup> Consistit agmen; impedimenta intra legiones recipiuntur. Si qua in parte nostri laborare aut gravius premi videbantur, eo signa inferri Caesar aciemque constitui jubebat: quae res et hostes ad insequendum 35 tardabat, et nostros spe auxilii confirmabat. <sup>4</sup> Tandem

Germani ab dextro latere, summum jugum nacti, hostes loco depellunt: fugientes usque ad flumen, ubi Vercingetorix cum pedestribus copiis consederat, persequuntur, compluresque interficiunt. Qua re animadversa, reliqui, ne circumirentur veriti, se fugae mandant. <sup>5</sup>Omnibus locis fit caedes. Tres nobilissimi Haedui capti ad Caesarem perducuntur: Cotus, praefectus equitum, qui controversiam cum Convictolitavi proximis comitiis habuerat; et Cavarillus, qui post defectionem Litavici pedestribus copiis praefuerat; et <sup>10</sup>Eporedorix, quo duce ante adventum Caesaris Haedui cum Sequanis bello contenderant.

68. Fugato omni equitatu, Vercingetorix copias, ut pro castris collocaverat, reduxit, protinusque Alesiam, <sup>15</sup>quod est oppidum Mandubiorum, iter facere coepit; celeriterque impedimenta ex castris educi et se subsequi jussit. <sup>2</sup>Caesar, impedimentis in proximum collem deductis, duas legiones praesidio relictis, secutus, quantum diei tempus est passum, circiter tribus milibus <sup>20</sup>hostium ex novissimo agmine interfectis, altero die ad Alesiam castra fecit. <sup>3</sup>Perspecto urbis situ, perterritisque hostibus, quod equitatu (qua maxime parte exercitus confidebant) erant pulsati, adhortatus ad laborem milites, circumvallare instituit.

<sup>25</sup>69. Ipsum erat oppidum Alesia in colle summo, admodum edito loco, ut nisi obsidione expugnari non posse videretur. Cujus collis radices duo duabus ex partibus flumina subleebant. <sup>2</sup>Ante id oppidum planities circiter milia passuum tria in longitudinem patebat; <sup>30</sup>reliquis ex omnibus partibus colles, mediocri interjecto spatio, pari altitudinis fastigio, oppidum cingebant. <sup>3</sup>Sub muro, quae pars collis ad orientem spectabat, hunc omnem locum copiae Gallorum compleverant, fossamque, et maceriam sex in altitudinem pedum praeduxerant. <sup>4</sup>Ejus munitionis, quae ab Romanis instituebatur, circuitus XI milium passuum tenebat. <sup>5</sup>Castra

opportunitis locis erant posita, ibique castella XXIII facta; quibus in castellis interdum stationes ponebantur, ne qua subito eruptio fieret: haec eadem noctu excubitoribus ac firmis praesidiis tenebantur.

70. Opere instituto, fit equestre proelium in ea planitie, quam, intermissam collibus, tria milia passuum in longitudinem patere supra demonstravimus. Summa vi ab utrisque contenditur. <sup>2</sup> Laborantibus nostris Caesar Germanos submittit, legionesque pro castris constituit, ne qua subito irruptio ab hostium peditatu fiat. <sup>3</sup> Praesidio legionum addito, nostris animus augetur: hostes, in fugam coniecti, se ipsi multitudine impediunt, atque angustioribus portis relictis coacervantur. Germani acrius usque ad munitiones sequuntur. <sup>4</sup> Fit magna caedes: nonnulli, relictis equis, fossam transire, et <sup>15</sup> maceriam transcendere conantur. Paulum legiones Caesar, quas pro vallo constituerat, promoveri jubet. <sup>5</sup> Non minus qui intra munitiones erant perturbantur Galli: veniri ad se confestim existimantes, ad arma conclamant; nonnulli perterriti in oppidum irrumpunt. <sup>20</sup> Vercingetorix jubet portas claudi, ne castra nudentur. Multis interfectis, compluribus equis captis, Germani sese recipiunt.

71. Vercingetorix, priusquam munitiones ab Romanis perficiantur, consilium capit, omnem ab se equitatum <sup>25</sup> noctu dimittere. <sup>2</sup> Discedentibus mandat, ut suam quisque eorum civitatem adeat, omnesque qui per aetatem arma ferre possint ad bellum cogant. <sup>3</sup> Sua in illos merita proponit; obtestaturque, ut suae salutis rationem habeant, neu se, optime de communi libertate meritum, <sup>30</sup> in cruciatum hostibus dedant. Quod si indiligentiores fuerint, milia hominum delecta LXXX una secum interitura demonstrat. <sup>4</sup> Ratione inita, se exiguae dierum triginta habere frumentum, sed paulo etiam longius tolerare posse parcendo. <sup>5</sup> His datis mandatis, qua <sup>35</sup> opus erat intermissum, secunda vigilia silentio equita-

tum dimittit ; frumentum omne ad se referri jubet ; capitis poenam iis qui non paruerint constituit ; pecus, cujus magna erat copia, ab Mandubiis compulsa, viritim distribuit ; <sup>6</sup> frumentum parce et paulatim metiri instituit ; copias omnes, quas pro oppido collocaverat, in oppidum recepit. His rationibus auxilia Galliae expectare et bellum parat administrare.

72. Quibus rebus cognitis ex perfugis et captivis, Caesar haec genera munitionis instituit : fossam pedum viginti directis lateribus duxit ; ut ejus fossae solum tantundem pateret, quantum summae fossae labra distarent. <sup>2</sup> Reliquas omnes munitiones ab ea fossa pedes quadringentos reduxit : id hoc consilio (quoniam tantum esset necessario spatium complexus, nec facile <sup>15</sup> totum corpus corona militum cingeretur), ne de improvise aut noctu ad munitiones hostium multitudo advolaret, aut interdium tela in nostros operi destinatos conicere possent. <sup>3</sup> Hoc intermisso spatio, duas fossas, xv pedes latas, eadem altitudine perduxit ; quarum interioriorem, campestribus ac demissis locis, aqua ex flumine <sup>20</sup> derivata complevit. <sup>4</sup> Post eas aggerem ac vallum xii pedum exstruxit : huic loricae pinnasque adjecit, grandibus cervis eminentibus ad commissuras pluteorum atque aggeris, qui adscensum hostium tardarent ; et tures toto <sup>25</sup> opere circumdedit, quae pedes lxxx inter se distarent.

73. Erat eodem tempore et materiari et frumentari et tantas munitiones fieri necesse, deminutis nostris copiis, quae longius ab castris progrediebantur ; ac nonnunquam opera nostra Galli temptare, atque eruptionem ex <sup>30</sup> oppido pluribus portis summa vi facere conabantur. <sup>2</sup> Quare ad haec rursus opera addendum Caesar putavit, quo minore numero militum munitiones defendi possent. Itaque truncis arborum admodum firmis ramis abscisis, atque horum delibratis ac praeacutis cacuminibus, <sup>35</sup> petuae fossae quinos pedes altae ducebantur. <sup>3</sup> Huc illi stipites demissi, et ab infimo revincti, ne revelli possent,

ab ramis eminebant. Quini erant ordines conjuncti inter se atque implicati; quo qui intraverant, se ipsi acutissimis vallis induebant. Hos Cippos appellabant. <sup>4</sup>Ante quos, obliquis ordinibus in quincuncem dispositis, scrobes tres in altitudinem pedes fodiebantur, paulatim <sup>5</sup>angustiore ad infimum fastigio. <sup>5</sup>Huc teretes stipites feminis crassitudine, ab summo praeacuti et praeusti, demittebantur, ita ut non amplius digitis quattuor ex terra emerent: simul, confirmandi et stabiliendi causa, singuli ab infimo solo pedes terra exculcabantur; reliqua <sup>10</sup>pars scrobis ad occultandas insidias viminibus ac virgultis integebatur. <sup>6</sup>Hujus generis octoni ordines ducti, ternos inter se pedes distabant. Id ex similitudine floris liliium appellabant. Ante haec taleae pedem longae, ferreis hamis infixis, totae in terram infodiebantur, mediocribusque intermissis spatiis, omnibus locis disserebantur, quos stimulos nominabant.

74. His rebus perfectis, regiones secutus quam potuit aequissimas pro loci natura, XIV milia passuum complexus, pares ejusdem generis munitiones, diversas ab <sup>20</sup>his, contra exteriorem hostem perfecit, ut, ne magna quidem multitudine, si ita accidat ejus † discessu, munitionum praesidia circumfundi possent; ac ne cum periculo ex castris egredi cogantur, dierum xxx pabulum frumentumque habere omnes convectum jubet. <sup>25</sup>

75. Dum haec apud Alesiam geruntur, Galli, concilio principum indicto, non omnes eos qui arma ferre possent, ut censuit Vercingetorix, convocandos statuunt, sed certum numerum cuique ex civitate imperandum; ne, tanta multitudine confusa, nec moderari nec discernere suos, nec frumentandi rationem habere possent. <sup>30</sup><sup>2</sup>Imperant Haeduis, atque eorum clientibus, Segusiavis, Ambluaretis, Aulercis, Brannovicibus, Brannoviis, milia xxxv; parem numerum Arvernibus, adjunctis Eleutheris Cadurcis, Gabalis, Vellaviis, qui sub imperio Arvernorum esse consueverunt; Sequanis, Senonibus, Biturigibus, <sup>35</sup>

Santonis, Rutenis, Carnutibus duodena milia; Bellovacis x; totidem Lemovicibus; octona Pictonibus et Turonis et Parisiis et Helvetiis; Senonibus, Ambianis, Mediomatricis, Petrorcoriis, Nerviiis, Morinis, Nitiobrigibus quina milia; Aulercis Cenomanis totidem; Atrebatibus iv; Veliocassis, Lexoviis, et Aulercis Ebuovicibus terna; Rauracis et Boiis. . .; xxx universis civitatibus quae Oceanum attingunt, quaeque eorum consuetudine Armoricae appellantur, quo sunt in numero  
 10 Curiosolites, Redones, Ambibarii, Caletes, Osismi, Lemovices, Unelli. <sup>3</sup> Ex his Bellovacii suum numerum non compleverunt, quod se suo nomine atque arbitrio cum Romanis bellum gesturos dicebant, neque cujusquam imperio obtemperaturos; rogati tamen ab Commio  
 15 pro ejus hospitio, duo milia una miserunt.

76. Hujus opera Commii, ut antea demonstravimus, fideli atque utili superioribus annis erat usus in Britannia Caesar: quibus ille pro meritis civitatem ejus immunem esse jusserat, jura legesque reddiderat, atque  
 20 ipsi Morinos attribuerat. <sup>2</sup> Tamen tanta universae Galliae consensio fuit libertatis vindicandae, et pristinae belli laudis recuperandae, ut neque beneficiis neque amicitiae memoria moverentur, omnesque et animo et opibus in id bellum incumberent. <sup>3</sup> Coactis equitum viii  
 25 milibus, et peditum circiter ccl, haec in Haeduorum finibus recensebantur, numerusque inibat, praefecti constituebantur: Commio Atrebatii, Viridomaro et Eporodorigi Haeduis, Vercassivellauno Arverno, consobrino Vercingetorigis, summa imperii traditur. <sup>4</sup> His delecti  
 30 ex civitatibus attribuuntur, quorum consilio bellum administraretur. <sup>5</sup> Omnes alacres et fiduciae pleni ad Alesiam proficiscuntur; neque erat omnium quisquam, qui adspectum modo tantae multitudinis sustineri posse arbitraretur, praesertim ancipiti proelio, cum ex oppido  
 35 eruptione pugnaretur, foris tantae copiae equitatus peditatusque cernerentur.

77. At ii qui Alesiae obsidebantur, praeterita die qua suorum auxilia expectaverant, consumpto omni frumento, inscii quid in Haeduis gereretur, concilio coacto, de exitu suarum fortunarum consultabant. <sup>2</sup>Ac variis dictis sententiis, quarum pars deditionem, pars, dum <sup>5</sup>vires suppeterent, eruptionem censebant, non praetereunda oratio Critognati videtur, propter ejus singularem ac nefariam crudelitatem. <sup>3</sup>Hic, summo in Arvernīs ortus loco, et magnae habitus auctoritatis: “Nihil,” inquit, “de eorum sententia dicturus sum, qui turpissimam <sup>10</sup>servitutem deditionis nomine appellant; neque hos habendos civium loco, neque ad consilium adhibendos censeo. <sup>4</sup>Cum his mihi res sit, qui eruptionem probant; quorum in consilio, omnium vestrum consensu, pristinae residere virtutis memoria videtur. Animi est <sup>15</sup>ista mollities, non virtus, paulisper inopiam ferre non posse. <sup>5</sup>Qui se ultro morti offerant facilius reperiuntur, quam qui dolorem patienter ferant. Atque ego hanc sententiam probarem (tantum apud me dignitas potest), si nullam praeterquam vitae nostrae jacturam fieri viderem; <sup>20</sup>sed, in consilio capiendo, omnem Galliam respiciamus, quam ad nostrum auxilium concitavimus. <sup>6</sup>Quid, hominum milibus LXXX uno loco interfectis, propinquis consanguineisque nostris animi fore existimatis, si paene in ipsis cadaveribus proelio decertare cogentur? <sup>7</sup>No- <sup>25</sup>lite hos vestro auxilio exspoliare, qui vestrae salutis causa suum periculum neglexerunt; nec stultitia ac temeritate vestra, aut animi imbecillitate, omnem Galliam prosternere et perpetuae servituti subicere. <sup>8</sup>An, quod ad diem non venerunt, de eorum fide constantiaeque dubitatis? Quid ergo? Romanos in illis ulterioribus munitio- <sup>30</sup>nibus animine causa cotidie exerceri putatis? <sup>9</sup>Si illorum nuntiis confirmari non potestis, omni aditu praesepto, his utimini testibus, appropinquare eorum adventum; cujus rei timore exterriti, diem noc- <sup>35</sup>temque in opere versantur. <sup>10</sup>Quid ergo mei consilii

est? Facere, quod nostri majores nequaquam pari bello Cimbrorum Teutonumque fecerunt; qui, in oppida compulsi, ac simili inopia subacti, eorum corporibus, qui aetate ad bellum inutiles videbantur, vitam toleraverunt, neque se hostibus tradiderunt. <sup>11</sup> Cujus rei si exemplum non haberemus, tamen libertatis causa institui, et posteris prodi, pulcherrimum judicarem. Nam quid illi simile bello fuit? Depopulata Gallia, Cimbri, magna-  
 5 neque illata calamitate, finibus quidem nostris aliquando  
 10 excesserunt, atque alias terras petierunt; jura, leges, agros, libertatem nobis reliquerunt. <sup>12</sup> Romani vero quid petunt aliud, aut quid volunt, nisi invidia adducti, quos fama nobiles potentesque bello cognoverunt, horum in agris civitatibusque considerare, atque his aeternam in-  
 15 jungere servitatem? Neque enim ulla alia condicione bella gesserunt. <sup>13</sup> Quod si ea quae in longinquis nationibus geruntur ignoratis, respicite finitimam Galliam, quae, in provinciam redacta, jure et legibus commutatis, securibus subjecta, perpetua premitur servitute!"

20 78. Sententiis dictis, constituunt ut ii qui valetudine aut aetate inutiles sunt bello, oppido excedant, atque omnia prius experiantur, quam ad Critognati sententiam descendant: illo tamen potius utendum consilio, si res cogat atque auxilia morentur, quam aut deditionis aut  
 25 pacis subeundam condicionem. <sup>2</sup> Mandubii, qui eos oppido receperant, cum liberis atque uxoribus exire coguntur. Hi, cum ad munitiones Romanorum accessissent, flentes, omnibus precibus orabant ut se, in servitatem receptos, cibo juvarent. At Caesar, dispositis in vallo  
 30 custodiis, recipi prohibebat.

79. Interea Commius reliquique duces, quibus summa imperii permissa erat, cum omnibus copiis ad Alesiam perveniunt; et, colle exteriore occupato, non longius mille passibus ab nostris munitionibus considunt. <sup>2</sup> Pos-  
 35 tero die, equitatu ex castris educto, omnem eam planitiem, quam in longitudinem tria milia passuum patere



demonstravimus, complent ; pedestresque copias, paulum ab eo loco abditas, in locis superioribus constituunt. <sup>3</sup>Erat ex oppido Alesia despectus in campum. Concurrunt his auxiliis visis ; fit gratulatio inter eos, atque omnium animi ad laetitiam excitantur. <sup>4</sup>Itaque, pro-  
ductis copiis, ante oppidum considunt, et proximam fossam cratibus integunt atque aggere explent, seque ad eruptionem atque omnes casus comparant.

80. Caesar, omni exercitu ad utramque partem munitionum disposito, ut, si usus veniat, suum quisque locum <sup>10</sup>teneat et noverit, equitatum ex castris educi et proelium committi jubet. <sup>2</sup>Erat ex omnibus castris, quae summum undique jugum tenebant, despectus ; atque omnes milites intenti pugnae proventum expectabant. <sup>3</sup>Galli inter equites raros sagittarios expeditosque levis armaturae interjecerant, qui suis cedentibus auxilio succurrerent, et nostrorum equitum impetus sustinerent. <sup>4</sup>Ab his complures, de improvise vulnerati, proelio excedebant. Cum suos pugna superiores esse Galli confiderent, et nostros multitudine premi viderent, ex omnibus parti-  
bus, et ii qui munitionibus continebantur, et hi qui ad <sup>15</sup>auxilium convenerant, clamore et ululatu suorum animos confirmabant. <sup>5</sup>Quod in conspectu omnium res gerebatur, neque recte ac turpiter factum celari poterat ; utrosque et laudis cupiditas et timor ignominiae ad vir-  
tutem excitabant. <sup>6</sup>Cum a meridie prope ad solis occasum dubia victoria pugnaretur, Germani una in parte confertis turmis in hostes impetum fecerunt, eosque propulerunt. <sup>7</sup>Quibus in fugam coniectis, sagittarii circumventi interfectique sunt. Item ex reliquis parti-  
bus nostri, cedentes usque ad castra insecuti, sui colligendi facultatem non dederunt. At ii qui ab Alesia processerant, maesti, prope victoria desperata, se in oppidum receperunt.

81. Uno die intermisso, Galli, atque hoc spatio magno <sup>35</sup>cratium scalarum harpagonum numero effecto, media

nocte silentio ex castris egressi, ad campestras munitiones accedunt. <sup>2</sup>Subito clamore sublato, qua significatione qui in oppido obsidebantur de suo adventu cognoscere possent, crates proicere, fundis, sagittis, lapidibus, nostros de vallo proturbare, reliquaque quae ad oppugnationem pertinent parant administrare. <sup>3</sup>Eodem tempore, clamore exaudito, dat tuba signum suis Vercingetorix, atque ex oppido educit. <sup>4</sup>Nostri, ut superioribus diebus, ut cuique erat locus attributus, ad munitiones accedunt; fundis, librilibus, sudibusque quas in opere disposuerant, ac glandibus Gallos proterrent. <sup>5</sup>Prospectu tenebris adempto, multa utrimque vulnera accipiuntur; complura tormentis tela coniciuntur. <sup>6</sup>At M. Antonius et C. Trebonius legati, quibus hae partes ad defendendum obvenerant, qua ex parte nostros premi intellexerant, his auxilio ex ulterioribus castellis deductos submittebant.

82. Dum longius ab munitione aberant Galli, plus multitudine telorum proficiebant; posteaquam propius successerunt, aut se stimulis inopinantes induebant, aut in scrobes delati transfodiebantur, aut ex vallo ac turribus trajecti pilis muralibus interibant. <sup>2</sup>Multis undique vulneribus acceptis, nulla munitione perrupta, cum lux appeteret, veriti ne ab latere aperto ex superioribus castris eruptione circumvenirentur, se ad suos receperunt. <sup>3</sup>At interiores, dum ea quae a Vercingetorige ad eruptionem praeparata erant proferunt, priores fossas expleant; diutius in his rebus administrandis morati, prius suos discessisse cognoverunt, quam munitionibus appropinquarent. Ita, re infecta, in oppidum reverterunt.

83. Bis magno cum detrimento repulsi, Galli quid agant consulunt. Locorum peritos adhibent; ex his superiorum castrorum situs munitionesque cognoscunt. <sup>2</sup>Erat a septentrionibus collis, quem, propter magnitudinem circuitus, opere circumplecti non potuerant nostri; necessario paene iniquo loco et leniter declivi

castra fecerant. <sup>3</sup> Haec C. Antistius Reginus et C. Caninius Rebilus, legati, cum duabus legionibus obtinebant. Cognitis per exploratores regionibus, duces hostium LX milia ex omni numero deligunt, earum civitatum quae maximam virtutis opinionem habebant; quid, <sup>5</sup> quoque pacto, agi placeat, occulte inter se constituunt; adeundi tempus definiunt, cum meridies esse videatur. <sup>4</sup> His copiis Vercassivellaunum Arvernorum, unum ex quattuor ducibus, propinquum Vercingetorigis, praeficiunt. Ille, ex castris prima vigilia egressus, prope <sup>10</sup> confecto sub lucem itinere, post montem se occultavit, militesque ex nocturno labore sese reficere iussit. <sup>5</sup> Cum jam meridies appropinquare videretur, ad ea castra quae supra demonstravimus contendit; eodemque tempore equitatus ad campestris munitiones accedere, et reliquae <sup>15</sup> copiae pro castris sese ostendere coeperunt.

84. Vercingetorix, ex arce Alesiae suos conspicatus, ex oppido egreditur: crates, longurios, musculos, falces, reliquaque quae eruptionis causa paraverat, profert. <sup>2</sup> Pugnatur uno tempore omnibus locis, atque omnia <sup>20</sup> temptantur: quae minime visa pars firma est, huc concurritur. <sup>3</sup> Romanorum manus tantis munitionibus distinctetur, nec facile pluribus locis occurrit. <sup>4</sup> Multum ad terrendos nostros valet clamor, qui post tergum pugnantibus exstitit, quod suum periculum in aliena vident salute <sup>25</sup> constare; omnia enim plerumque, quae absunt, vehementius hominum mentes perturbant.

85. Caesar, idoneum locum nactus, quid quaque ex parte geratur cognoscit; laborantibus submittit. Utrisque ad animum occurrit, unum esse illud tempus, quo <sup>30</sup> maxime contendere conveniat: <sup>2</sup> Galli, nisi perfregerint munitiones, de omni salute desperant; Romani, si rem obtinuerint, finem laborum omnium exspectant. Maxime ad superiores munitiones laboratur, quo Vercassivellaunum missum demonstravimus. <sup>3</sup> Iniquum <sup>35</sup> loci ad declivitatem fastigium magnum habet momen-

tum. Alii tela coniciunt, alii testudine facta subeunt; defatigatis in vicem integri succedunt. <sup>4</sup> Agger, ab universis in munitionem coniectus, et ascensum dat Gallis, et ea quae in terra occultaverant Romani con-  
 5 tegit; nec jam arma nostris nec vires suppetunt.

86. His rebus cognitis, Caesar Labienum cum cohortibus sex subsidio laborantibus mittit. Imperat, si sustinere non posset, deductis cohortibus, eruptione pugnaret; id nisi necessario ne faciat. <sup>2</sup> Ipse adit reliquos; co-  
 10 hortatur ne labori succumbant; omnium superiorum dimicationum fructum in eo die atque hora docet consistere. <sup>3</sup> Interiores, desperatis campestribus locis propter magnitudinem munitionum, loca praerupta ex ascensu temptant: huc ea quae paraverant conferunt.  
 15 Multitudine telorum ex turribus propugnantes deturbant; aggere et cratibus fossas explent; falcibus vallum ac loricam rescindunt.

87. Mittit primo Brutum adolescentem cum cohortibus Caesar, post cum aliis C. Fabium legatum; postremo ipse, cum vehementius pugnaretur, integros subsidio adducit. <sup>2</sup> Restituto proelio ac repulsis hostibus, eo quo Labienum miserat contendit; cohortes quattuor ex proximo castello deducit, equitum partem sequi, partem circumire exteriores munitiones et ab  
 25 tergo hostes adoriri jubet. <sup>3</sup> Labienus, postquam neque aggeres neque fossae vim hostium sustinere poterant, coactis una quadraginta cohortibus, quas, ex proximis praesidiis deductas, fors obtulit, Caesarem per nuntios facit certio-  
 30 rem quid faciendum existimet. Accelerat Caesar, ut proelio intersit.

88. Ejus adventu ex colore vestitus cognito, quo insigni in proeliis uti consuerat, turmisque equitum et cohortibus visis quas se sequi jusserat, ut de locis superioribus haec declivia et devexa cernebantur, hostes  
 35 proelium committunt. <sup>2</sup> Utrimque clamore sublato, excipit rursus ex vallo atque omnibus munitionibus clamor.

Nostri, omissis pilis, gladiis rem gerunt. Repente post tergum equitatus cernitur; cohortes aliae appropinquant: hostes terga vertunt; fugientibus equites occurrunt; fit magna caedes. <sup>3</sup>Sedulius, dux et princeps Lemovicum, occiditur; Vercassivellaunus Arvernus vivus in fuga <sup>5</sup>comprehenditur; signa militaria LXXIV ad Caesarem referuntur; pauci ex tanto numero se incolumes in castra recipiunt. <sup>4</sup>Conspicati ex oppido caedem et fugam suorum, desperata salute, copias a munitionibus reducunt. <sup>5</sup>Fit protinus, hac re audita, ex castris Gallorum fuga. <sup>10</sup>Quod nisi crebris subsidiis ac totius diei labore milites essent defessi, omnes hostium copiae deleri potuissent. <sup>6</sup>De media nocte missus equitatus novissimum agmen consequitur: magnus numerus capitur atque interficitur; reliqui ex fuga in civitates discedunt. <sup>15</sup>

89. Postero die Vercingetorix, concilio convocato, id bellum se suscepisse non suarum necessitatum sed communis libertatis causa demonstrat; et, quoniam sit fortunae cedendum, ad utramque rem se illis offerre, seu morte sua Romanis satisfacere, seu vivum tradere velint. <sup>2</sup>Mittuntur de his rebus ad Caesarem legati. Jubet arma tradi, principes produci. Ipse in munitione pro castris consedit: eo duces producuntur. Vercingetorix deditur; arma proiciuntur. <sup>3</sup>Reservatis Haeduis atque Arvernibus, si per eos civitates recuperare posset, <sup>25</sup>ex reliquis captivis toto exercitui capita singula praedae nomine distribuit.

90. His rebus confectis, in Haeduos proficiscitur; civitatem recipit. Eo legati ab Arvernibus missi quae imperaret se facturos pollicentur. Imperat magnum <sup>30</sup>numerum obsidum. Legiones in hiberna mittit; captivorum circiter xx milia Haeduis Arvernisque reddit. <sup>2</sup>T. Labienum duabus cum legionibus et equitatu in Sequanos proficisci jubet; huic M. Sempronium Rutilum attribuit. C. Fabium legatum et L. Minucium <sup>35</sup>Basilum cum legionibus duabus in Remis collocat, ne quam

ab finitimis Bellovacis calamitatem accipiunt. <sup>3</sup>C. Antistium Reginum in Ambilaretos, T. Sextium in Bituriges, C. Caninium Rebilum in Rutenos, cum singulis legionibus mittit. Q. Tullium Ciceronem et P. Sulpicium Cabilloni et Matiscone in Haeduis ad Ararim rei frumentariae causa collocat. Ipse Bibracte hiemare constituit. His litteris cognitis, Romae dierum viginti supplicatio redditur.



## ARGUMENT OF BOOK VIII.

NOTE. — This Book is understood, by general consent, to have been written as a continuation by Aulus Hirtius, an officer of Cæsar, who also wrote the history of the campaigns in Africa and Spain. Hirtius was killed near Mutina (*Modena*), in battle against Mark Antony, in the year following Cæsar's death, B.C. 43.

FINAL CONQUEST AND PACIFICATION OF GAUL. — Scattered uprisings quelled (1-5). War of the Bellovaci, who at length submit (6-22). After a series of scattered and petty actions (23-35), Uxellodunum is besieged by Cæsar (37, 38). Its defenders, being prevented from access to water, are compelled by distress to surrender: Cæsar orders the hands to be cut off of all who have borne arms (39-44). Aquitania is recovered, the Treveri are subdued, and the last resistance is overcome by the defeat of Comius (45-48). Cæsar deals generously with the vanquished, and proceeds to Italy, where he is magnificently welcomed (49-51). Outbreak of the jealousies at Rome which led to the Civil War (52-55).

## NOTES.



The Legionary.



## THE LEGIONARY.

---

THE core of the Roman army was the legionary infantry. This was composed entirely of Roman citizens; while the auxiliary infantry, the archers and slingers, and the cavalry, were of various barbarian nationalities. These other troops were used for subordinate purposes only. It was intended that the weight of the battle should be borne by the legions.

The recruit must be over 17 and under 46 years of age, of sound bodily health and of suitable size. What the limits of height were in the Roman army, we do not know.\* From the fact that the legionary fought with sword and spear, and not with the breech-loading rifle of modern wars, we may infer that he must have been more muscular and agile than is now necessary; but we cannot infer that he was of unusual size. On the contrary, there is little doubt that the soldiers who conquered the world for Cæsar were, as a rule, rather under-sized. The historians always emphasized the bigness of the Germans, and Cæsar expressly mentions the small stature of his troops.† The Romans had learned the lesson of civilization, — that victories in war are gained, not by huge bones and big bodies, but by the trained skill of scientific organization and tactics. Any one of the German giants might perhaps have been more than a match for any individual of his puny Italian enemies. But the barbarian mob of Ariovistus was shattered when hurled against the spears of the legions.

All the legionaries were clothed, armed and equipped alike. Next the skin was worn a sleeveless woollen shirt (*tunica*). Over this was a leathern coat strengthened by bands of metal across breast and back and on the shoulders (*lorica*). The troops in Trajan's column are represented with tight-fitting trowsers (*braccae*) extending below the knee. It seems likely, however, that these did not come into use among the Romans until after Cæsar's time.‡ Possibly strips of cloth were worn wound around the thighs (*feminalia*) and around the shins (*cruralia*). The feet were protected by sandals (*calcei*), or by strong shoes not unlike those worn at the present time. Then, in cold or wet weather, the person was covered by the military cloak (*sagum*), a sort of woollen blanket. Of course, this was laid aside in battle.

The defensive armor consisted of helmet, greaves and shield. The helmet was either of iron (*cassis*), or of leather or cork strengthened with brass (*galea*). That of the officer was distinguished by a plume of red or black feathers (*crista*). The greaves (*ocreae*) were of bronze. They were used to protect the leg below the knee, and were held in place sometimes by straps, sometimes by their own stiffness. Usually but one was worn, on the right leg, as this was the one advanced in the fight. (The greaves may be seen in the picture of the centurion, Fig. 4.) The shield (*scutum*) was

\* In our infantry, no one is received whose height is less than 5 ft. 4 in., or more than 5 ft. 10 in.

† Tacitus, *De Germania*, I. 4. Cæsar, *B. G.* I. 39; II. 30.

‡ The trowsers in the picture of the legionary (p. 2) are without doubt of a later age.

of wood, covered with leather or with iron plates. In the centre was a boss (*umbo*), which was merely a knob designed to strengthen and bind all together. The shield was about 4 ft. long and 2 ft. wide. Often it was curved, so as partially to encircle the body. On the outside was painted the badge of the cohort, — a wreath, or a winged thunderbolt, for instance.

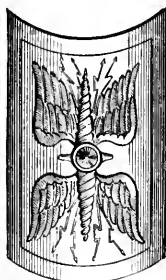

Fig. 1. *Scutum*.

On the inside was the name of the soldier, with the number of the cohort and maniple; perhaps also the number of the legion. The offensive weapons were the sword and spear. The sword (*gladius Hispanicus*) had a blade about 2 ft. long and several inches wide. It was two-edged and pointed, being thus adapted either for cutting or thrusting. The latter, however, was its customary use. It hung seldom from a body-belt, generally from a shoulder-belt (*baltus*) passing over the left shoulder. Thus the sword was on the right side, this being more convenient since the shield was carried in the left hand. As the higher officers had no shields, they wore their swords on the left side. The spear (*pilum*) was the characteristic weapon of the legionary. Its entire length was between 6 and 7 ft. The shaft was of wood, round or square, and was upwards of 4 ft. long. Into this was fitted the slender iron shank (*ferrum*) of the spear, which terminated in a steel head. When the *pilum* was hurled into some object of attack, the soft iron of the shank bent under the impetus of the blow, and the weapon was thus unfitted to be drawn out and cast back by the enemy. At the bottom of the shaft was an iron shoe, so that in camp, or during a rest on the march, the spear might be set up in the ground. The weight of the entire weapon must have been about 9 pounds. In early times the legionary had two *pila*. In the army of Cæsar, however, we have reason to believe that each soldier had but one.



Fig. 2.  
*Gladius*.

Cæsar fixed the pay of his legionaries at 225 denarii a year (about \$45). A day laborer in Rome at that time earned  $\frac{3}{4}$  of a denarius a day; or, in a year of 300 working days, just as much as a legionary. Thus the soldier was better off than the laborer merely by his shelter and by certainty of employment. For food and equipments, so far as they were provided by the state, a deduction from the pay was made. As provision, each man was allowed per month 4 measures (the measure, *modius*, = 8.67 litres, or a little over a peck) of wheat. The measure may be estimated to be worth at the highest  $\frac{3}{4}$  of a denarius. Thus the amount deducted for food cannot have exceeded 36 denarii a year. However, in the provinces, the food, if not given outright, was reckoned at a very low price; and the same must have been true of clothing and equipments. Moreover, the soldier in active service always expected an increase to his income from booty and from the gifts of his general.



Fig. 3.  
*Pilum*.

## TO THE STUDENT.



AS CÆSAR, though in many respects a book for advanced students, is often the first Latin classic put into the learner's hands, it may be well to give a few hints as to the method of study.

1. Before beginning to read, the learner should be familiar with the forms of Inflection, the simpler rules of Agreement and Construction of Cases (Grammar, p. 381 ff.; see, especially, Rules 1-7, 13, 14, 21, 38, 54), and the Definitions contained in §§ 171-180.

2. Notice at once the inflectional terminations, so that the number, case, tense, person, &c., — i.e. the relations of the idea conveyed to the rest of the connected ideas, — may be present to your mind. If the form of the word gives several possibilities, hold them all in your mind, so far as may be, till something occurs to settle the doubt.

3. Always try to take in the ideas in that order in which the Latin presents them. Read every word as if it were the last on a page and you had to turn over without being able to turn back. The mind soon becomes accustomed to the order of any language; as we see by the constant and almost unnoticed inversions of common speech and poetry. The greatest difficulty to a beginner is his inability to remember the first parts of a complex idea. This difficulty can often be lessened by jotting down, in a kind of English, the words as they come in the Latin. In this way it is often easy to see what a string of words *must* mean, though we should never say anything like it in English.

4. Don't try to *translate* (except as suggested in 3) until you have got a complete *idea* of some *integral part* of the sentence. It makes nonsense to render words mechanically, without thinking the corresponding ideas.

5. When you get on far enough, notice that the emphatic position of words plays a most important part in Latin writing, and try to feel the emphasis of position as you read. (See Appendix, p. 120, and A. & G. Latin Grammar, Revised ed., Chap. VI.)

## BOOK FIRST. — B.C. 58.

HELVETIAN WAR.—Early in the year 58 B.C., the whole population of Helvetia (northern Switzerland), amounting to about 360,000, attempted to pass by an armed emigration through the heart of Gaul, in order to settle somewhere near the shore of the Bay of Biscay, possibly with the hope of being masters of the whole country. They were hemmed in by the great natural barriers of the Alps, the Lake of Geneva, and the Jura Mountains on the south and west; and pressed on the north by great hordes of Germans, who kept up a continual border war. Their fields were scant, their harvests insufficient, their people hardy and fearless. Their ambitious chief, Orgetorix, had prepared them so well for this enterprise, that his flight and death—when he was charged with guilty conspiracy, and put on trial for his life—caused no delay. The attempt was held in check by Cæsar, during a fortnight's parley, till sufficient earthworks had been thrown up along the Rhone to withstand their advance; the advance was then made in force along the narrow pass between that river and the Jura. But the Helvetians did not succeed in getting more than fifty miles beyond the frontier, when they were overtaken by Cæsar; who, by a few light skirmishes and two bloody battles, forced them back to their own territories, with the loss of more than 200,000 lives. This brief campaign, lasting only from March to June, is called the Helvetian War.

**N.B.** *References are made by chapters and sections. The Grammars cited are those of Allen & Greenough (§), Gildersleeve (G.), and Harkness (H.).*

PAGE

**2.** CHAP. I. **Gallia**, that is, independent Gaul, excluding the Roman province (*Provincia*) in the south-east, as well as *Gallia Cisalpina*, now northern Italy. It occupied the territory of France, including to the Rhine boundary, with most of the Netherlands and Switzerland (see Map).

**omnis** (predicate), *as a whole*. — **est divisa**, *is divided*: the adjective use of the participle, not the perfect passive (§ 291. *b*; G. 439. R.; H. 550. N. 2).

**Belgae**, probably of the *Cymric* branch of the Celtic race, allied to the Britons and the modern Welsh: they inhabited the modern *Belgium* and northern France, and were considerably mixed with Germans (see ii. 1). — **Aquitani**, of the Spanish Iberians (the modern *Basques*), inhabiting the districts of the south-west (see iii.

20). — **Celtae**, probably of the *Gaelic* branch, represented by the Irish and the Highland Scotch.

**aliam**: **alteram** would be more usual, as meaning the second in the list. — **tertiam qui . . . appellantur**, *the third* [those inhabit] *who are called*, &c. It would read in full, **tertiam** [partem ii incolunt] **qui**, &c. (§ 200. c; G. 621; H. 445. 6). — **ipsorum linguā**, *in their own tongue*. — **nostrā**, sc.\* **linguā**.

**linguā** (abl. of specification, § 253 (R. 26); G. 398; H. 424) . . . **differunt** [Et. 344], † *differ in language, customs, and laws*. The language of the Aquitani was Basque; of the Gauls proper, Celtic; of the Belgians, probably Celtic mixed with German. (Observe that when three words, as **lingua**, &c., are used together, by Latin use there should be no conjunction at all, as here; or both conjunctions should be expressed; or that between the first two words may be omitted, and **que** annexed to the last.)

**inter se** = *from one another*: the preposition **inter** may be used to show any *reciprocal* relation, see § 196. f; G. 212; H. 448. N.

**dividit**: the verb is singular, because the two rivers make one boundary (§ 205. b; G. 202. R.<sup>1</sup>; H. 463. ii. 3); as we should say, *is divided by the line of the Seine and Marne*.

2. **horum**, part. gen. with **fortissimi**, § 216. a (R. 10); G. 370; H. 397. 3. — **propterea quod**, *because*; lit. *because of this, that*, &c. These adverbial phrases, which are numerous in Latin, should always be carefully analyzed, though generally rendered by a single word in English. (Beginners constantly confound **propterea**, *for that reason*, with **praeterea**, *besides*.)

**cultu**, *civilization*, as shown by outward signs; **humanitate**, *refinement*, of mind or feeling. The two, taken together, make a kind of *hendiadys* (see Glossary, Gr. p. 298; G. 695; H. 636. iii. 2): *the refined mode of life*.

**provinciae**: the province of *Gallia Narbonensis*, organized about B.C. 120. Its chief cities were Massilia (*Marseilles*), an old Greek free city, and the capital, Narbo (*Narbonne*), a Roman colony. The name *Provincia* has come down in the modern *Provence*.

**minime saepe commeant**, *least often penetrate*. The verb

\* Understand (*scilicet*).

† The abbreviation "Et." refers to Halsey's "Etymology of Latin and Greek" (Ginn, Heath, & Co.).

**commeo** means, especially, *to go back and forth* in the way of traffic. The main line of trade lay across the country, by the river Loire. — **mercatores**: these were traders or pedlers, mostly from the seaport of Massilia; they travelled with pack-horses, mules, and wagons. A very common article of traffic (as with our Indian traders) was intoxicating drinks, — wines from the southern coast; which, especially, as Cæsar says, “tend to debauch the character.” These people, it is said, would give the traders a boy for a jar of wine.

**ea**, object of **important**. — **effeminandos**, § 300; G. 428; H. 544. — **Germanis**, dat. of *nearness*, &c. (§ 234. a; G. 356; H. 391. 1).

**trans Rhenum**: the Rhine was, in general, the boundary between Gauls and Germans; though, as we shall see, a few German tribes had settled on the hither side.

**continenter** (adverb from the participle of **contineo**, *hold together*), *incessantly*; strictly, *without any interruption*.

**quoque**: i.e. just as the Belgians. — **reliquos**, *rest of*: § 193; G. 287. R.; H. 440.

3. **qua de causa**, *and for this reason* (§ 180. f; G. 612; H. 453): explained by **quod . . . contendunt**.

**Helvetii**, here, it will be noticed, reckoned as Gauls. — **præcedunt**, *excel*; lit. *walk before*.

**proeliis**, abl. of means; **finibus**, abl. of separation. — **cum prohibent**, *while they keep them off* (**pro-habeo**). Observe that this conjunction is not properly spelled **quum**, on account of the old rule forbidding **u** to follow **u** or **v** in the same syllable (§§ 7, 156; G. 7; H. p. 15, foot-note 1); but **cum** or **quom**. — **ipsi** (emphatic), *themselves*, the Helvetians; **eos** and **eorum** refer to the Germans. — **bellum**, Et. 231.

4. **eorum una pars**, *one division of them* (the Gauls), the people being put for the country. — **quam . . . dictum est**, *which (it has been [already] said) the Gauls hold*. [Notice that in direct discourse it would be **Galli obtinent**: the subject-nom. is changed to acc., and the indic. to the infin. after the verb of *saying*, **dictum est**, § 272. R.<sup>2</sup> (R. 39); G. 527; H. 535. 1.] Here **quam** is the object and **Gallos** the subject of **obtinere**; while the clause is the subject of **dictum est** (§§ 329, 330. a<sup>2</sup>; G. 528; H. 538). — **initium**, Et. 493. — **obtinere** (**ob-teneo**), not *obtain*, but *occupy*:

strictly, *hold against* all claimants; what is called in law *adverse possession*. (**Ob** in composition almost always has the sense of *opposing* or *coming in the way of* any thing.)—**continetur**, *is bounded*.

**ab Sequanis**, *on the side of*, &c.—**vergit**, &c., *slopes to the north*; that is, the highlands (*Cevennes*) are along the southern boundary, and the rivers flow in their main course northerly.

**septentriones** (*septem triones*, “the seven plough-oxen”), i.e. the constellations of the great and little Bear. The word is used both in the singular (as a compound) and in the plural.

5. **Galliae**, i.e. Celtic Gaul (the country just described), not *Gallia omnis*.—**inter occasum**, &c., *north-west*, i.e. from the Province.

**3. ad Hispaniam**, *next to Spain*, i.e. the Bay of Biscay (§ 259. f; H. 433. 1).

CHAP. 2. **nobilissimus** (root GNO, *know*), *of highest birth*. Popular revolutions had, among the Gauls as among the Greeks and Romans, mostly dispossessed the old chiefs, or kings; and they had established an annual magistrate called *Vergobret* (ch. 16). But the heads of the ruling families would naturally be ambitious to recover what they could of the old class power; and Orgetorix is represented as aspiring to create a monarchy in Gaul.

**Orgetorix**: this name, by a probable derivation, means *the slayer*.

**Messala**, &c. (Gr. p. 294): this was B.C. 61, three years before Cæsar's first campaign in Gaul. The construction of **consulibus** is abl. absolute (§ 255 & a (R. 35); G. 408; H. 431): not so formal as *while Messala and Piso were consuls*, but merely *in their consulship*. This was the usual way of denoting the year.—**inductus**, Et. 12.

**conjuracionem**, *a league*, sworn to fidelity by oath (**juro**).—**nobilitatis**: from the account given in ch. 4, we see how immense was the class power still held by the nobles.

**civitati persuasit**, § 227 (R. 16); G. 345; H. 385. ii.: the direct object of **persuasit** is the clause **ut . . . exirent** (§ 331. a; G. 546. R. 1; H. 498); compare **id**, two lines below [Et. 493]. Votes were easily “persuaded” by such means as Orgetorix possessed. (For the sequence of tenses in **exirent**, see § 286. Rem.; G. 510; H. 495. ii.).

**perfacile** (predicate with **esse**, while its subject is the infinitive clause with **potiri**): *that it was quite easy, since they exceeded all men in valor, to win the empire of all Gaul.* — **esse**, indirect disc., depending on some such word as *he said* (§ 330 *e*; G. 652. R.<sup>2</sup>; H. 523. I. N.).

**cum praestarent**, subjunctive after **cum**, meaning *since*, §§ 325, 326; G. 587; H. 517. — **imperio**, § 249 (R. 31); G. 405; H. 421.

2. **hoc facilius**, *all the easier*: § 250 (R. 33); G. 400; H. 423. — **id**, obj. of **persuasit** (§ 225. *c*; G. 344; H. 384. 2): we should say, *persuaded them of it*. Usually with **persuadere** the dat. and acc. are *both* used only when the latter is a pronoun. See Madvig, 242. Obs. 1. — **loci naturā**, *by the nature of the country.* — **continentur**, *are hemmed in*.

**una ex parte**, *on one side*: as in **undique**, *on* (lit. *from*) *all sides*, **hinc**, *on this side*, &c. The effect on the senses is supposed to come *from* the direction referred to. — **latissimo**, *very broad* (§ 93. *b*; H. 444. 1). — **qui** refers not to **flumine**, but to **Rheno**.

3. **his rebus**, *by these causes.* — **fiebat** (imperf.) = *it was coming about more and more* (§ 277; G. 222; H. 468–9): the subject is the clause **ut . . . possent** (see § 332. *a*; G. 558; H. 501. i.).

**qua ex parte**, *on which ground*: some editions have **qua de causa**. — **homines** (a sort of apposition) = *being* (as they were) *men eager for war.* — **bellandi** [Et. 231], § 218. *a* (R. 12); G. 374; H. 542. i.

**adficiebantur** = **afficiebantur**: for the rule as to assimilation of consonants, compare § 11. *f*<sup>3</sup>. In this edition the *unchanged* form of the preposition is usually preferred.

4. **pro**, *in proportion to.* — **multitudine**: their numbers, including some small dependent populations, were 368,000 (see ch. 29). — **angustos fines** = *too narrow limits*: those here given are about 40 miles each way larger than the present boundaries of Switzerland.

**milia passuum**, *miles* (1000 paces), the regular way of stating this measure, **milia** being acc. of *extent of space* (R. 23), and **passuum** partit. genitive. The **passus** was the *stretch* from heel to heel, i.e. from where the heel is raised to where it is set down again; and is reckoned at five Roman feet. A Roman mile (*mille passuum*) was about 400 feet less than ours; it measures the distance which a soldier would march in “a thousand paces.”



**patebant**: throughout the latter part of this chapter notice the use of the imperfect of *description* or *general statement*, compared with the perfect of *simple narrative* in **persuasit** above, and **constituerunt**, &c., below.

CHAP. 3. **adducti**: Et. 12. — **permoti**: this word seems to show something more than mere “persuasion” on the part of Orgetorix, cf. ch. 2<sup>1</sup>. — **quae pertinerent**, dependent clause in indir. disc., § 341. *d*; G. 653; H. 524.

Observe that Latin employs different moods for the two forms of quotation, one for what is called Direct and the other for Indirect Discourse. Whenever the writer or speaker takes the responsibility of the statement, it is put in the Indicative, with commands in the Imperative. These are the moods of DIRECT DISCOURSE. When anything is told not simply as a fact, but that *some one perceived, thought, or said so*, the leading statement is put in the Infinitive, and all subordinate parts (including commands) in the Subjunctive. These are the moods of INDIRECT DISCOURSE. The narrative in this chapter will require a careful attention to the above distinction. Let the learner here study attentively the introductory paragraph and Remark of § 335 (G. 651; H. 522). In Cæsar, nearly all the speeches are given in the form of narrative: that is, in Indirect Discourse.

**comparare . . . confirmare**: these infinitives are construed as the *direct object* of the leading verb **constituerunt**, § 271. *a*; G. 424; H. 533, i. 1.

**quam maximum**, *as great as possible* (§ 93. *b*, 207; G. 317; H. 170. 2). — **jumentorum**, *beasts of burden*, properly, *yoke-animals* (root YU, kindred with JUG in **jungo, jugum**); **carrorum**, two-wheeled *carts*, suited to the narrow and rough roads.

2. **conficiendas** (FAC: Et. 256), *completing*: **con** in composition generally means *together*; or, as here, may be simply intensive. — **lege**: probably passed in a public assembly, which is what a Roman would understand by **lex**. — **in tertium annum confirmant**, *fix for the third year*.

3. **sibi suscepit**, *took on himself*. Observe the force of **sub**, as if he put his shoulders *under* the load. — **civitates**, *clans*, such as the Ædui, Sequani, &c., — about 60 in all, — whose territory had no local name, but was known only by that of the clan, which was sovereign and wholly independent, except for voluntary alliances (see ch. 30). The name **Gallia** itself — as was said of Italy

a few years ago — was only “a geographical expression,” implying no political sovereignty.

**persuadet**, *prevails on*: **suadet** would be, simply, *urges*. — **obtinuerat**, *had held*. — **amicus**, an honorary title given by the Roman Senate to friendly powers. — **ut . . . occuparet**, *to lay hands on*. This clause is the object of **persuadet** (§ 331. *a*; G. 546; H. 499. 3; for the sequence of tenses, see § 287. *e*; G. 511. R.<sup>1</sup>; H. 492), which in English would be expressed by the infinitive. — **regnum**, here, not hereditary authority, but personal rule: what the Greeks called *tyranny*. — **ante**, here an adverb; in English we should say *before him*.

**Dumnorigi** (dat. after **persuadet**, p. 4), Dumnorix, a younger brother, restless, ambitious, and strongly attached to the old aristocracy of the clan: therefore a bitter enemy of the Roman supremacy. He afterwards headed a desertion of Cæsar’s cavalry, just before the second invasion of Britain, but was pursued and killed (v. 6).

**4. Divitiāci**: this Æduan chief was of the order of Druids; he had been in Rome, where he made the acquaintance of Cicero and other eminent Romans. He was thoroughly impressed with the power and superiority of the Romans, and was a faithful friend and ally of Cæsar.

The name is by some thought to be a Druid title. The party of Druids, represented by Divitiacus and Liscus (chap. 16), was the *popular* party, strong especially in the large towns: it was opposed by the old clan feeling kept up by military or tribal chiefs (*principes*), such as Orgetorix and Dumnorix. The former, or popular party, was headed by the Ædui; the latter, or aristocratic, by the Sequani and Arverni. The Druids were a religious or priestly order, jealous of the aristocracy (*equites*) of the tribe or clan, which represented what may be called the patriotic or “native-Celtic” party (see vi. 12–17). A knowledge of this division helps clear up many of the events of Cæsar’s campaigns. Divitiacus was a name well known at Rome. A later writer gives an interesting picture of the Gallic chief standing and leaning on his shield while he made his appeal before the senate, declining (as a suppliant) the seat which was in courtesy offered him.

**qui**, i.e. Dumnorix. — **principatum**, *highest rank*, as distinct from political power. — **plebi acceptus**, *a favorite with the people*

(acceptable to the people). — **ut idem conaretur**, *to make the same attempt* (lit. *attempt the same thing*); i.e. put down the constitutional authority, and establish a rule of military chiefs.

4. **perfacile factu** (§ 303. R.; G. 437. R.<sup>1</sup>; H. 547), *very easy to do*: in predicate agreement with **conata perficere**, which is subj. of **esse**, depending on **probat**. — **illis probat**, *undertakes to show them*, i.e. to Casticus and Dumnorix (conative present, § 276. b; G. 218. R.<sup>2</sup>; H. 467. 6).

**non esse dubium quin**, *there is no doubt (he says) that*: here **esse** is infin. of indirect disc.; for the construction of **quin**, see § 319. d; G. 551; H. 501. ii. 2. — **Galliae**, partitive gen. with **plurimum**. — **plurimum possent** = *were the strongest*. — **confirmit**, *asserts* (confidently).

5. **oratione**, *plea, or argument* (abl. of means). — **fidem et iurandum**, i.e. *assurance confirmed by oath* (hendiadys). — **regno occupato** (abl. absolute, expressing *condition*, see §§ 255, 310. a; G. 408. R., 670; H. 431. 2 (3)), *in case they should get in their hands the royal power*: = **si occupaverimus**. — **per tres populos**, i.e. Helvetii, Ædui, and Sequani; a league between these, they hope, will secure their power over all Gaul. — **posse**, equivalent to a future infinitive (see § 288. f; G. 240. R.<sup>3</sup>; H. 537. N. 1); Madvig, 410. Obs. 1). — **Galliae**, governed by **potiri**; see § 249. a; G. 405; H. 410. v. 3.

CHAP. 4. **ea res**, *this thing* (i.e. conspiracy). The word **res** would often be best rendered by some more specific word in English, as *action, fact, event, estate, &c.*, according to the passage. The Helvetians were prepared to emigrate in a body, and subdue the rest of Gaul; but not to surrender to Orgetorix the power thus acquired. His act was treason, — a conspiracy within a conspiracy.

**moribus suis**, *according to their custom* (abl. of specification). — **ex vinclis** (= **vinculis**; so *hindrance* for *hinderance* in English), *out of chains*, i.e. standing in chains. A Latin idiom, cf. **ex equo**, *on horseback*. — **causam dicere** [Et. 10], *to plead his cause*, a technical expression for being brought to trial.

**damnatum** (sc. **eum**, object of **sequi**), *if condemned*. (In this sentence the subject of **oportebat** is the clause **damnatum** . . . **sequi**; the subject of **sequi** is **poenam**; and **ut** . . . **cremaretur** is in apposition with **poenam**, defining the punishment: § 332. f; G.

559; H. 501. iii.) Translate, *it must needs be that the penalty should overtake him, if condemned, of being burned with fire.* (For the ablative in *i*, see § 57. *b*<sup>1</sup>; G. 60. 3. *a*; H. p. 35, foot-note 2. This form is often used by Cæsar and earlier writers.) Observe that *urere* would mean merely *to burn*, while *cremare* is *to burn to ashes*.

2. *die constituta*, *on the day appointed*, § 256 (R. 34); G. 392; H. 429: for the gender of *die*, see § 30. *a*. 73; G. 70; H. 123.— *causae dictionis*, [Et. 10], *of the pleading of the cause* (it would be more usual to say *dicendae*); *dictionis* depends on *die*, and *causae* is the obj. gen. after *dictionis*.

*ad iudicium* [Et. 125, 10], *near the* [place of] *judgment*.— *familiam*, *clansmen*: by Roman use this would mean *slaves*; but it is more probable that it here means all who bore his name or regarded him as their chief.— *ad . . . decem milia*, *to* [the number of] 10,000.— *clientes*, *retainers*, volunteer or adopted followers; *obaeratos*, *debtors*, the only class of slaves that seems to have been known in Gaul, see vi. 13, 2.— *conduxit*; Et. 12.— *per eos*, *by their means* (§ 246. *b*; G. 403; H. 415. i. 1, N. 1).

3. *cum . . . conaretur*, *when the state attempted*: relative time, § 323. N.<sup>1</sup>; G. 586; H. 521. ii. 2.— *neque . . . suspitio* (the true spelling of this word), *and the suspicion is not wanting*. The negative *neque* (= *and not*) is often best translated by dividing in this way.

*quin . . . consciverit (conscisco)*, *that he decreed death to himself (his own death)*, i.e. *committed suicide*. Observe that *ipse*, *self*, agrees in Latin rather with the subject; not, as in English, with the object. “Orgetorix (it will be noticed) was never in the power of the magistrates, he was not put in chains, nor did he die in prison.”

CHAP. 5. *nihilominus* (often written in one word, as in English), *nevertheless*.— *constituerant*, *had resolved*: observe the pluperfect, as following the historical present.— *ut . . . exeant*, in apposition with *id*: as we should say, “namely, to go forth.”

*ubi arbitrati sunt*, *when they judged*: observe the regular use of the perfect indicative with *ubi*, *postquam*, &c., § 324; G. 563; H. 518.— *rem*, *enterprise*.— *oppida*, *towns*, fortified and capable of defence; *vicos*, *villages*, i.e. groups of houses about a single spot. (In a city, *vicus* is a *street*, considered as the houses occupied; *via* is the travelled way between them.) The villages and houses were

burned, partly to cut off hope of return; partly to prevent their being occupied by their enemies, the Germans. — **incidunt**, *set fire to*.

**praeterquam** [id] **quod**, *excepting what (that which)*: observe that in this phrase **quam** means *than*, and **praeter** is the comparative of **prae**: lit. *further than what*. — **domum**, § 258. *b*; G. 410; H. 380. 2<sup>1</sup>, following **reditionis**. — **comburunt** **burn up**. — **subeunda**, Et. 493. — **molita cibaria**, *ground corn (flour)*: every man to take his own supply for three months' use.

2. **Rauracis**, &c., German tribes from the banks of the Rhine. — **uti**, the older form for **ut**, common in Cæsar. — **una cum iis**, *along with them* (lit. *by one way*). — **proficiscantur**: Et. 256. — **oppidis . . . exustis**, *having burned*, &c. (See § 113. *c. N.*; G. 409. *R.*<sup>1</sup>; H. 550. *N.*<sup>4</sup>).

**Boios** (from whom the name *Bohemia* is derived): a Celtic tribe, whom the great German advance had cut off from their kins-people towards the west, and who were now wandering homeless, some of them within the limits of Gaul.

5. **Noricum**, &c., now eastern Bavaria and upper Austria. — **receptos . . . adsciscunt**: in English, in a sentence like this, we should use a separate verb instead of the participle (§ 292; G. 667; H. 549. 5). Translate, *they receive the Boii into their own number (ad se)*, and vote them in as allies to themselves.

CHAP. 6. **omnino**, *in all*, i.e. *only*. — **itineras, itineribus** [Et. 493]: observe the form of this relative sentence (common in Cæsar), which gives the antecedent noun in both clauses. It is usually omitted in one or the other (see § 200; G. 617; H. 453. 2): in English, almost always in the relative clause; in Latin, quite as often in the other. — **possent**, subjunctive in a relative clause of characteristic (§ 320; G. 633; H. 503. I.).

**Sequanos**, i.e. the region now called *Franche Comté*, north of the Rhone. — **inter . . . Rhodanum**: the pass now guarded by the Fort *l'Ecluse*, about nineteen Roman (eighteen and a half English) miles below Geneva (compare note, chap. 8: 1). The Rhone at this part was the boundary of the Roman province. The choice was between crossing the river, and proceeding along its northern bank. — **flumen**: Et. 345. — **vix qua**, &c., *where carts could scarcely be hauled in single file* (see § 95. *a*; G. 95; H. 174. 2). — **autem** = *then again*.

2. **multo facilius**, *much easier* in itself; but it required them to crush the Roman legion at Geneva, and force their way through about 50 miles of territory occupied by the Roman arms. — **propterea quod**, see note to Chap. 1<sup>2</sup>. — **nuper pacati erant**, *had been lately subdued* (reduced to peace). A rebellion "of despair" (B.C. 61), had been subdued by C. Pomptinus.

**locis**, loc. abl. (§ 258. *f*; G. 385; H. 425. II. 2). — **vado**, *by ford* (*wading, vadendo*). The bed of the Rhone has changed somewhat since Cæsar's time. There is now but one ford between Geneva and the *Pas-de-l'Ecluse*.

**Genua** (**Genva**) is nearest to the modern German name (*Genf*); it is also spelled *Genava* and *Geneva*.

3. **sese persuasuros** [*esse*] (notice that in the future infinitive, used in indirect discourse, **esse** is usually omitted; in direct disc. it would be **persuadebimus**), *they thought they should persuade*; its object is **Allobrogibus**. — **bono animo** = *well disposed*: five years before, their envoys in Rome had intrigued with Catiline's agents, whom they at length betrayed (see Cicero, *Cat.* iii. § 22).

4. **a. d. v. Kal. Apr.**, nominally March 28 (§§ 376, 259. *e*; G. App.; H. 642. 3). According to the astronomer Leverrier, the true date was March 24, the day of the spring equinox; Mommsen makes it as late as April 16. The calendar was in a state of great confusion at this time, and till Cæsar's reform, 12 years later.

**CHAP. 7. Caesari**: he was at this time at Rome, having laid down his consulship, preparing to set out for his province. Every consul was entitled to the governorship of a province for one year after his term of office, and by a special law Cæsar's government (consisting of the three *provinces* of Cisalpine and Transalpine Gaul and Illyricum) had been conferred for a term of five years. This news hastened his movements.

**id**, in appos. with **eos** . . . **conari** (the real subject of **esset**), *that they were attempting to force a march, &c.* — **maturat**, *hastens*; travelling, his biographers say, 100 miles in a day, and reaching the Rhone in a week, according to Plutarch. The subject, **Caesar**, is here omitted with the leading verb, being expressed in the relative clause. — **ab urbe**: this word, unless some other place is indicated, always means Rome, THE CITY. Cæsar was *near*, but not *in* the

city, not being permitted to enter it while holding the military authority (*imperium*) of proconsul. Hence he says **ab**, not **ex**.

**quam maximis potest itineribus** (§ 93. *b*; G. 317; H. 170. 2); **potest** is usual with Cæsar in this phrase, which is elliptical. In full it would be, **tam magnis quam maximis**, *as great as the greatest*; i.e. *the greatest possible* (Chap. 10<sup>3</sup>).

**ulteriorem**, i.e. beyond the Alps. The northern part of modern Italy was still called *Gallia Cisalpina*, and was a part of Cæsar's province.

2. **provinciae (dat.) imperat**, *makes requisition on the province*: i.e. Transalpine Gaul.

THE ROMAN LEGION.—The normal strength of the legion has been variously estimated up to 6000 men. We have reason to believe that in Cæsar's army it did not exceed 5000 (see note on Bk. IV. Chap. 37). As to a far more important fact, the actual strength in the field, we are much better informed. It seems quite clear that the average field strength of Cæsar's legion did not vary far from about 3600 men; and that number we will consider the basis of our estimates. This legion, or brigade, as we should perhaps call it, was divided into 10 cohorts, or small battalions, of about 360 men each. The cohort consisted of 3 maniples or companies, about 120 strong. As the cohort was the tactical unit of the legion, so the maniple was the tactical unit of the cohort. Each of these military units contained from day to day essentially the same men, under the same officers. The maniple, however, was divided, on a different principle, into two equal parts, called *ordines*, or *centuriae* (centuries). When the men fell in for morning roll-call, for instance, the maniple was formed according to height. The taller soldiers would thus form the first *ordo*, the rest, the second. Thus some men might one day be in one *ordo*, and another day in the other, as on successive days different squads might be detailed from the maniple for guard duty or other special service. The *ordo* corresponded exactly to the platoon in an American company.

The officers of the legion were the tribunes (*tribuni militum*) and the centurions (*centuriones*). Of the former, each legion had six, who had charge in turn, two at a time. They did not command the legion in battle unless specially detailed for that purpose. Their duties were what is called *administrative*, i.e. having to do with the levying and discharge, the equipment and supplies of the troops; and *judicial*, i.e. they tried and punished offenders against military law. Of the centurions, the real leaders of the legion, there were two to each maniple. The senior (*prior*)

commanded the first platoon, and the junior (*posterior*), the second. The cohorts and their centurions were graded in rank from the tenth up to the first. Thus the centurions of the first cohort were of the first rank (*primorum ordinum*). The centurions occupied a place about midway

between that of a commissioned officer and that of a non-commissioned officer in a modern army. They commanded the maniples, and in battle the first centurion of the first cohort may almost be said to have commanded the legion (but see note on Chap. 52). On the other hand, their duties were much like those of a sergeant. They were chosen from the ranks for their experience and skill, and were seldom appointed to a higher position. The tribunes, together with the officers in the general staff of the army, were usually appointed from the noble families at Rome through some political influence.



Fig. 4. Centurio.

3. *certiores facti sunt*, were informed (made more certain). — *qui dicerent*, who were [instructed] to say (§ 317; G. 544; H. 497. I.). — *sibi . . . liceat*: observe carefully the construction of the indirect discourse (§ 336. *a* and *b*; G. 653; H. 523–531): in direct discourse it would be, “*Nobis est in animo sine ullo maleficio iter per provinciam facere, propterea quod aliud iter habemus nullum; rogamus, ut tua voluntate id nobis facere liceat.*” A little atten-

tion to this in the beginning will relieve this construction, very frequent in Cæsar, of all difficulty.



**sibi**, dat. of possession (§ 231; G. 349; H. 387); of **esse**, the subj. is the clause **iter . . . facere**, while the whole passage **sibi . . . liceat**, is the object of **dicerent**. Render, *that they had [it was to them] in mind to make, &c.* — **aliud . . . nullum**, like the English, *other passage had they none.* — **rogare**: of this verb the subject is **se**, understood; and the object is the clause **ut . . . liceat** (§ 331. a; G. 546, and R.<sup>1</sup>; H. 498. 1); *they begged it might be allowed them to do this with his consent.*

4. **L. Cassium . . . occisum** [esse], object of **memoriā tenebat**, as a phrase of *knowing* (§ 272. R.<sup>1</sup>; G. 527; H. 371. IV. 535. 1<sup>1</sup>). This defeat happened B.C. 107, in the terrible invasion of the Cimbri or Teutons, the Helvetians being their allies. “The army of Cassius was one of six swept away by these barbarians.”

6. **sub jugum** [Et. 125] *under the yoke* (hence the word *subjugate*). The *jugum* was made by sticking two spears in the ground, and laying another across them above. To pass under this was equivalent to *laying down arms* by a modern army.

**concedendum** [esse], depending on **putabat**, impersonal: *thought that no concession should be made*, lit. “that it must not be yielded.”

**homines**, subj. of **temperaturos** [esse], depending on **existimabat**: *he judged that men of hostile temper* (abl. of quality, § 251; G. 402; H. 419. II.), *if the opportunity were given* (abl. absolute) *of making a march* (gerundive, §§ 297, 298; G. 429; H. 544. 1) *through the province, would not (neque) refrain from wrong and mischief.*

5. **dum . . . convenirent** (§ 328; G. 574; H. 519), *until the men should muster.* — **diem se sumpturum** [esse], *he would take time.* **si quid . . . reverterentur** (subj. for imperat. § 339; G. 655; H. 523. III.): in direct discourse, *if you wish anything (said he), return on the 13th of April.*

CHAP. 8. **eā legione**, *with that legion* (abl. of instrum.). In this sentence, observe how all the qualifying clauses come first, and the direct objects, **murum**, **fossam**, come next before the leading verb **perducit** (§ 343; G. 676; H. 560); while each relative belongs to the verb which comes next after it unless another relative intervenes, — a very convenient rule in analyzing a long and difficult sentence.

**decem novem, nineteen**, following the windings of the river (see note, Chap. 6). — **murum**: this rampart, or earthwork, was on the south side of the river, leaving the passage undisputed along the northern bank.

The banks of the Rhone in this part are generally rugged and steep, with sharp ravines; there are only five short reaches — a little over three miles in all — in this course of eighteen miles requiring defences. The current is in general quite rapid. Some remains of Cæsar's works can still be traced, according to the French engineers who surveyed the ground under the orders of Napoleon III. According to Cæsar's statement, the work was continuous (this is the meaning of *perducit*). This undoubtedly means that, after the five accessible points were strengthened by artificial defences, the entire left bank of the Rhone, from Geneva to *Pas-de-l'Écluse*, formed a continuous barrier against the Helvetians. The construction of any one of the fortifications may be described as follows: —

Along the crest of the ridge facing the river, the slope was cut so as to be vertical, or nearly so, and then a trench was hollowed. The earth dug out was partly thrown up to increase the height of the wall, and quite likely

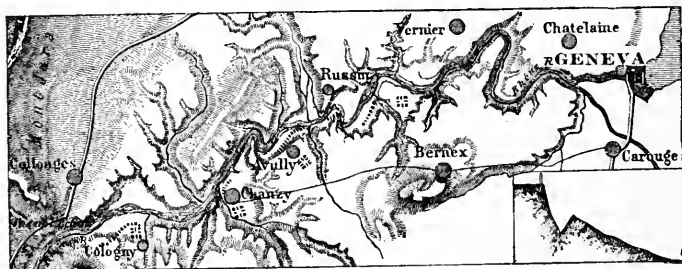

0 1 2 3 4 Kilometres  
1 Kilometer = .62137 of a mile.

Plan I. *Fortifications on the Rhone.* Bk. I. Ch. 8.

The dotted lines indicate wall and trench; the dotted squares, redoubts. In the lower corner at the right is a vertical section of *murus* and *fossa*. From Genf (Geneva, see note on Chap. 6<sup>2</sup>) to Pas-de-l'Écluse (or Pas-d'Écluse), 18½ (English) miles by the river, is only half that distance in a straight line.

in part thrown down the hill. At all events, it seems probable that the measure of 16 feet is the distance from the bottom of the ditch to the top

of the wall. Thus the work formed really little more than a trench with scarp higher than the counterscarp. Then the crest was fortified with a breastwork of palisades, behind which the soldiers were protected while hurling their missiles at the enemy. This entire series of works, with the force at Cæsar's command, could not have occupied more than two or three days.

2. **castella** (literally "little fortifications"), *redoubts*. These were constructed on the same plan as the camp, but were much smaller. They were rectangular, and surrounded by wall and ditch. In them were stationed guards (*praesidia*). The redoubts were sufficiently numerous, so that the guard from one or another could quickly reach any point in the lines that might be threatened. — **quo facilius possit**, *that he may the more easily*: the usual construction (§ 317. b; G. 545. 2; H. 497. II. 2). — **se invito** (abl. abs.), *against his will*.

3. **negat se posse**, *says he cannot*. — **si conentur**, future condition in indirect discourse: direct, it would be **si conabimini**. — **prohibiturum** [se esse] **ostendit**, *shows that he shall stop them*.

4. **dejecti** [Et. 493], *cast down*: **de** in composition generally has the meaning *down*. — **nonnunquam**, *sometimes* (§ 150 and a; G. 448 and R.<sup>4</sup>; H. 553. 1). — **si . . . possent**, an indirect question (§ 334. f; G. 603, 462. 2; H. 529. I. N.<sup>1</sup>), depending on **conati**: *trying if they could break through*. — **conatu**, abl. of separation, following **destiterunt**, *desisted*.

CHAP. 9. **Sequanis invitis** (abl. abs. of condition), *in case the Sequani should refuse*. — **sua sponte**, *by their own influence*: a rare meaning of this phrase, which is generally, *of their own accord*. — **eo deprecatore** (abl. absolute denoting means), *by his means as advocate*. — **impetrarent**, *they might obtain* [it].

2. **gratiā**, *personal influence*; **largitione**, lavish gifts and hospitalities, like those of old chiefs of the clan. — **duxerat**: this word is used of the man who marries a wife, i.e. he *leads* her to his own house; of the woman it is said, **nubit viro** (dat.), i.e. she *puts on the veil* for him. This refers to the flame-colored veil (*flammeum*) worn by the bride during the wedding ceremonies. — **novis rebus** (dat. § 227. e; G. 346. R.<sup>2</sup>; H. 384. I.), *revolution*, change in the state. — **studebat**, *eagerly favored*. — **habere obstrictas**, *to keep close bound*.

3. **impetrat** has for obj. **ut . . . patiantur**; and **perficit, uti . . . dent**: *obtains* (from their good will) *that they will allow the Helvetii to go, &c., and brings it about that they exchange hostages.*

7. CHAP. 10. **renuntiatur**, *word is brought back*, i.e. from messengers sent to ascertain: the subject is the clause **Helvetiis esse**, &c. (see note Chap. 7<sup>3</sup>).—**Tolosatum**, the people of *Tolosa*, the modern *Toulouse*.

The Santones give the name to the modern province of *Saintonge*, on the Bay of Biscay. This is so far from the borders of the Province, as to show that Cæsar was only searching for a pretext; for of course he had no authority to interfere, unasked, with a passage through the territory of the Sequani. One motive in writing the Commentaries, we must remember, was to produce political effect in Rome.

2. **fieret**: Et. 256.—**futurum [esse] ut haberet**, &c., *it would be to the great peril of the province* (§ 329. N.; G. 507; H. 501. 1) *that it should have*: the clause **ut . . . haberet** being subject of **futurum [esse]**, a kind of periphrastic future (§ 288. *f*; G. 240; H. 537. 3) carried into the past by sequence of tenses (**intellegebatur**).—**locis** (loc. abl.) **patentibus**, *in an open country*: the S. W. part of Gaul is a broad river valley, giving easy access to the province.

3. **munitioni præfecit**, *he put in command of the fortification*. **Labienum**: this was Cæsar's best officer, a prominent and influential politician, of strongly democratic sympathies. He served Cæsar faithfully through the Gallic wars, but when the Civil war broke out, he joined what he conceived to be the party of the republic, went over to Pompey, and was killed at Munda.

**legatum**, *legate, lieutenant*: no English word exactly translates this. The *legatus* was employed by the commander as his trusted assistant in the most important duties,—to negotiate treaties, to lead independent armies, to command single legions. His place was thus entirely distinct from the what is known in modern armies as the general staff, or from the commander's aides-de-camp. There were generally three *legati* assigned to the commander by the Senate, his wishes being considered in the selection. Cæsar (who was

now, through the triumvirate, all-powerful in Rome) had ten. — in **Italiam**: i.e. Cisalpine Gaul, now coming to be regarded as a part of Italy.

**magnis itineribus**, as in Chap. 7.<sup>1</sup> It is also the usual phrase for *forced marches* of an army. The ordinary day's march of the Romans was about 15 miles; a *magnum iter* was from 20 to 25 miles.

Each legionary carried, besides his arms and armor, a portion of the entrenching tools (spades, saws, baskets, etc.), spare clothing, material for repairing dress or equipments, his blanket (*sagum*), hand-mills, cooking utensils, and rations. On a long march, these last would be carried by the



Fig. 5.

1. *Funditor.* 2, 2. *Milites levis armaturae.* 3, 3. *Legionarii.*

pack animals. As Cæsar was making a forced march in pursuit of the Helvetians, however, it seems likely in the present case that his men had to carry a good share of their food. Additional supplies followed the army in boats on the Saône (see Chap. 16). The ration for one day was about 2 pounds, and consisted of coarse flour, or unground grain which the soldier must grind for himself. The various articles of baggage were made

up into bundles (*sarcinae*), and these were bound to the upper end of a pole (*furca*) some 5 or 6 ft. long. On the march this pole was carried on the shoulder. During a halt it could be rested on the ground, and the soldier could lean on it for support. These poles (forked at the top) were a device of the ingenious Marius, and hence were called by the soldiers "Marius's mules" (*muli Mariani*). The entire weight carried by each man could not have been less than 60 pounds; not very different from the load a modern soldier has on the march.

**Aquileiam**: an important Roman colony at the head of the Adriatic. It continued to be the chief port of trade for this region till outgrown by Venice. — **educit**: Et. 12.

**qua proximum iter**, i.e. by way of Susa and Turin, by Mt. Genève. Ocelum is identified with *Oulx* (or *Houlx*), a little southwest of Turin. The more direct way by Mt. Cenis began to be used under Augustus.

4. **compluribus** . . . **pulsis**, interlocked order, his agreeing with **pulsis** (§ 344. *h*). — **ab Ocelo pervenit**, came through from Ocelum. — **trans Rhodanum**, towards the west, as the Rhone, at Lyons, turns abruptly to the south. His object was to head off the Helvetians, who had advanced westwardly, north of the upper course of the river, and had now reached the territory of the Ædui. Cæsar's army by this time amounted to nearly 25,000 men; the Helvetians had between 80,000 and 100,000 warriors to oppose him, with (probably) at least 8500 wagons.

CHAP. 11. **jam traduxerant** [Et. 12], had already brought across; **per angustias**, i.e. through the *Pas de l'Ecluse*, before described. The emperor Napoleon III. enters into a calculation to show that Cæsar's absence cannot have occupied less than two months; so that the following events took place in the latter part of June. — **rogatum** (supine), to ask.

2. **ita se**, understand **dicentes** or some such word. In direct discourse, this will be, "Ita [*nos*] . . . *meriti sumus*, ut pæne in conspectu exercitus tui, . . . *liberi nostri* . . . *non debuerint*": We have so deserved . . . that our fields ought not to have been wasted, &c.

**meritos**: "Alone among the Gauls," says Tacitus, "the Ædui claim the name of brotherhood with the Roman people" (Ann. xi.

25). There was even a later fiction of a common descent from Troy for the Arverni (Lucan, i. 427). So it was an old notion that Britain had its name from Brutus, a grandson of Ascanius.

3. **Haedui Ambarri**, the *Ædui near the Arar* (or *Saône*), occupying the angle between that river and the Rhone. (Some editions omit *Haedui* in this title; others write, *eodem tempore quo Aedui, Ambarri quoque*.)

**necessarii**, close connections (bound by *necessitudo*, or community of interests of any kind); **consanguinei**, blood-kindred.

**depopulatis agris . . . prohibere**, their fields were already wasted, and they were with difficulty attempting to keep off, &c. (see § 292. R.; G. 667. R.<sup>1</sup>; H. 549. 5).

8. 4. **nihil esse reliqui** (part. gen.), there is nothing left to them, except the very soil of the fields.

5. **non expectandum (esse)**, must not wait (lit. it was not to be waited). — **sociorum**: the Helvetians would be sure to levy upon the allies of the Romans wherever they found them.

CHAP. 12. **flumen, &c.**, the *Arar* (*Saône*) is a river which flows through, &c.; not *between*, which would be expressed by **dividit**. The *Saône* joins the *Rhone* about 75 miles south-west of Lake Geneva. — **lenitate**, not so much *slowness* as *smoothness*; contrasting not only with the *Rhone*, but with the swiftness and turbidness of the rivers in Italy.

**ratibus**, rafts of logs; **lintribus**, canoes of hollowed logs, joined, perhaps, two and two, with a broad deck covering them. The swift streams of the south of Europe are often crossed by boats swung from moorings at some distance up-stream, and carried across either way by the force of the current. — **in . . . fluat**, indir. question following **judicari**.

2. **exploratores**, scouts; a detachment of cavalry always preceded the army and scoured the country in every direction to get news of the enemy. — **partes**, object of **duxisse**; **flumen** governed by **trans** in composition (§ 239. b; G. 330. R.<sup>1</sup>; H. 376), had conveyed three fourths . . . across this river. — **Ararim**: for the acc. in **im**, see §§ 55. d, 56. a<sup>1</sup> (names of rivers); H. 62. III. 1. — **reliquam** = **relictam**: in fact this adjective is, from its meaning, a kind of participle.

**de tertia vigilia** : the night, from sunset to sunrise, was divided into four equal watches, the third beginning at midnight. This movement took place directly after (**de**) the watch began.

3. **concidit** (**con, caedo**), *cut to pieces*. — **mandarunt** = **mandaverunt** (§ 128. a; G. 191<sup>b</sup>; H. 235), *abandoned* (lit. *gave in hand, manu, do*); **abdiderunt**, *hid* (lit. *put away*).

**pagus** : this "district" (*Tigurinus*) is about the modern *Zürich*. The inhabitants of the *pagus* probably composed a clan, and formed a division of the force.

4. **L. Cassium**, see Chap. 7.<sup>4</sup> — **deorum** : this reference to a special providence is noticeable in so stern a realist as Cæsar, and was probably for political effect. Compare his curious account of the divine omens which accompanied his victory over Pompey, B.C. iii. 105.

**quae pars intulerat . . . ea persolvit**, render *that part which*, &c. (see § 200. b. N.; G. 622; H. 445. 9).

**poenas persolvit**, *paid the penalty*. Punishment was regarded among the ancients, not as *suffering* to be *inflicted*, but as of the nature of a *fine* or *penalty* to be *paid*; hence **sumere**, *to inflict*, and **dare** or **solvere**, *to suffer*.

In 1862, numerous remains were discovered buried in two trenches, probably of those slain in this battle, — "pell-mell, skeletons of men, women, and children." — *Hist. of Julius Cæsar*.

5. **injurias** [Et. 125], *wrongs*, not simply *damage*, as the word came to mean afterwards. From Cæsar's point of view, an offensive war against Rome is necessarily wrong. Besides, hostility or friendship towards a foreign state might become a family tradition, and so a bounden duty. — **ultus est**, *avenged*.

**soceri** : L. Calpurnius Piso, father of Shakespeare's *Calphurnia*, and consul of the present year (see end of Chap. 6).

CHAP. 13. **consequi**, *overtake* (hence the frequent meaning *acquire*). — **pontem faciendum curat**, *has a bridge made* (§ 294. d; G. 431; H. 544). — **pontem**; with the van of the army marched a body of engineers, who could rapidly bridge any ordinary river. This was very likely a bridge of boats. It must be observed, however, that the Romans always preferred a ford to a bridge, whenever practicable. They had no powder to keep dry. — **in, upon**, not simply *over*.



2. **cum . . . intellegeret**, clause of relative time (§§ 323, 325; G. 586; H. 521. II. 2). — **id**, object of **fecisse**, and in appos. with **ut . . . transirent**. — **diebus viginti**, *in the course of 20 days* (§ 256; G. 392; H. 429).

**legatos**, a participle of **lego** (*depute*), used as a noun; hence, diplomatically, *envoy* or *ambassador*, and in military affairs *lieutenant*. — **legationis**, a collective noun, and so answering (by *synesis*) to the plural **legatos**. — **Divico**, now an old man, since the battle in which he was commander took place 49 years before.

9. 3. **si pacem**, &c.: compare the form of direct discourse given to this address, Grammar (A. & G.), p. 251. — **in eam partem . . . ubi**, *to whatever part*, i.e. of Gaul. They were not, however, to be turned back from their migration. — **reminisceretur** (subj. for imperative): *remember* [said he]. — **incommodi**, *disaster* (lit. *inconvenience*; cf. “*the late unpleasantness*,” for our civil war): for the government of the genitive, see § 219; G. 375; H. 406. II.

4. **improviso**, *unexpectedly, by surprise* (properly abl. abs. § 255. b; G. 438. R.<sup>2</sup>; H. 431. N.<sup>2</sup>). — **suis**, *to their own people* (§ 190. a; G. 195. R.<sup>1</sup>; H. 441. 1). — **ne tribueret** (for imperative), *he should not ascribe it*. — **dolo**, *craft*: **insidiis**, *ambuscade*.

5. **ne committeret ut**, &c., i.e. *let him not commit the error*, &c. (§ 332. e; G. 557; H. 498. II. N.<sup>2</sup>). — **ubi constitissent**, *where they had taken their stand* (notice the intensive force of **con**).

CHAP. 14. **eo** (abl. of cause) **minus . . . quod, . . . teneret**, *he had all the less hesitation because he kept in mind*, &c.

**eo gravius . . . quo minus** (§§ 106. c, 250. R.; G. 400; H. 423): *he was the more incensed, in proportion as the Roman people had less deserved*, &c.

2. **qui si fuisset**, *now if they* (the Roman people) *had been*. — **non fuisse** (for **fuit** of dir. disc.), *it would not have been*. — **eo deceptum** [esse], *they had been deceived by this*.

**quare timeret** = **propter quod**, referring to **id** (understood), subject of **commissum** [esse], in the sense of *anything that should give them fear*, and follows **intellegeret**: *because they* (the Roman people) *did not know what they had done to be afraid of*.

3. **quod si** (§ 240. b; G. 331. R.<sup>2</sup> 612. R.<sup>1</sup>; H. 453. 6) . . . **vellet**, *but if they should consent to forget*, &c. — **num posse** = *could they*, &c.

**injuriarum**, obj. of **memoriam**. — **eo invito** = *against his will*. — **quod . . . vexassent** is a clause of *fact*, properly indicative, § 333; G. 525; H. 516, but subj. by indirect discourse.

4. **sua**, *their own* (the Helvetians); so **se tulisse** (= **intulisse**), *that they had committed*. The clause **quod . . . admirarentur** is subj. of **pertinere**: *As for their boasting* [because they boasted] *so insolently of their victory, &c., it comes (amounts) to the same thing* (lit. *to the same place*).

5. **quos . . . his**, *to grant an interval of prosperity and longer impunity to those whom they wish to punish for their guilt*: the relative clause, as usual, preceding the demonstrative (§ 201. c; G. 622; H. 572. II. N.). “Divico had not said anything in the way of direct boasting. This eloquent passage was perhaps an answer to his manner, or to the fact that he was the same Divico who had slain Lucius Cassius.” Observe the change to primary tenses, when the language of Cæsar expresses a general truth.

6. **cum**, *though* (§ 326; G. 588; H. 515. III.). — **sibi**, *to him*, Cæsar. — **facturos**, sc. **eos**. — **Haeduis**, dat. after **satisfaciant**, *pay damages*. — **ipsis**, dat. after **intulerint**.

**10. CHAP. 15. equitatum**: the cavalry was wholly made up of contingents furnished by subjects (of the provinces) or allies (as the *Ædui*). — **coactum habebat**, lit. *had collected* (§ 292. c; G. 230; H. 388. I. N.): more strictly *held* (had in hand) *after being collected*.

2. **cupidius**, *too eagerly* (§ 86. b, 93. a; G. 312; H. 444. I.). — **novissimum agmen**, *the rear*: **agmen** is the army in line of march (**ago**); and its *newest* part is that which comes along last. — **alieno loco**, *an unfavorable ground* (“another’s”); so **suo** would be *favorable* (“one’s own”).

3. **sublati (tollo)**, *elated*. — **equitibus**, abl. of means. — **subsistere**, *to make a stand*. — **novissimo agmine** (loc. abl.), *at their rear*.

4. **satis habebat**, *held it sufficient*. — **hostem . . . prohibere**, in appos. with **satis**, as object of **habebat**.

5. **ita, uti**, *in such a way that* (correl.). — **quinis, senis**, distributives, implying that this was the *constant* or *average* distance between the two armies. The country here is very irregular and broken; so that it was impossible for Cæsar to get any advantage by a rapid march, or by an attack on the Helvetian rear.

CHAP. 16. **cotidie** = **quotidie** (see § 7; G. 7). — **Haeduos frumentum**, demanded corn of the *Ædui* (§ 239. c; G. 333; H. 374). — **flagitāre**, historical infinitive (§ 275. R.; G. 650; H. 536. 1). — **flagitāre** means an earnest and repeated demand accompanied with reproaches. — **frigora**, the cold seasons, or spells of cold: not the cold in general. The climate of Gaul in Cæsar's day was much colder than that of France now (see Parke Godwin's Hist. of France, p. 11). The change has come from clearing away the forests, and draining the marshes which then covered much of the country. — **frumenta**, the plural is regularly used of standing grain. — **pabuli**, green fodder (root in **pasco**). The crops of grain (*frumenta*) were not ripe because it was too early in the season (about the last of June); the green fodder was scarce because Cæsar was following in the path of the Helvetians, whose thousands of cattle had swept the country bare. — **frumento**, object of **uti**. — **flumine**, § 258. g; but G. 387 and H. 420. — **navibus**, § 248; G. 403; H. 414. 4. — **propterea . . . quod**, see Chap. 1.<sup>2</sup> — **ab Arare**: i.e. towards the valley of the Loire, westerly.

2. **ducere** (histor. infin.), dragged on. — **conferri**, &c. [frumentum]: as English has no present passive form, translate, "said it was getting together, was coming in, was close by." — **metiri**, measure out: the allowance was about 30 pounds a fortnight. — **Divitiaco**, **Lisco**, abl. in appos. with **principibus**. — **summo magistratui**, **præerat**, held the chief office, of which the Celtic title was *guerg breth*, "executor of judgment," represented in Latin by *vergobretus*. — **in suos**, over his people.

¶ 3. **necessario** (attrib.), at so urgent a time; **propinquis** (not attrib., but pred.), with the enemy so near.

CHAP. 17. **privatim plus possint**, have more power in private station: some copies read **privati**, as private men.

2. **improba oratione**, reckless talk. — **ne** (§ 331. e; G. 548; H. 505. II.) . . . **præferre**, from bringing (lest they bring) the corn which they were bound to furnish; [representing that] if they could no longer hold the chief rank in Gaul, they prefer the rule of Gauls to [that of] Romans.

This sentence gives a good example of what is called a Various Reading. It must be remembered that these Commentaries were first written as rough

notes, or memoranda, and were afterwards copied by hand for centuries before their form was fixed by printing. The sentence as it stands is that given in the best editions; some of which, however, have **perferre**, *bear*, for **præferre**, *prefer*. In the above rendering, **præstare** has the active meaning, *to furnish*: and **quam** the meaning *than*, after the comparative implied in **præferre**. This makes the sense clear, but is awkward and hard. To remedy it, the neatest and best conjecture is to put the pause after **conferant**, read **debeat** for the plural **debeant**, and **perferre** for **præferre**, thus: "detertere ne frumentum conferant; quod præstare debeat, si jam principatum Galliae obtinere non possint, Gallorum quam Romanorum imperium perferre." Here **quod** is *because*, and **quam** follows the comparative in **præstare**, taken in the neuter sense of *excel*: and the passage reads, *from bringing in the corn, since it must be better (præstare debeat) to bear, &c.* But there is no manuscript authority for **debeat**. Some would read **dicant** for **debeant**: *since, they say, it is better, &c.*; but this is mere conjecture. Others, again, put **satius esse** after **perferre**; but this is only an explanatory note, written by some early editor.

**neque dubitare quin**, § 319. *d*; G. 551. 2; H. 505. I. — **debeant**: a word given thus in brackets is one of which the authority is doubtful; it may sometimes require to be omitted in translation. — **superaverint**, perf. subjunctive for fut. perf. ind. (same form) of direct disc. — **Haeduis**, dative, § 229; G. 346; H. 385. II. 2.

3. a **se**, i.e. by Liscus, as chief magistrate. — **quin etiam**, *nay even*: often written as one word. — **quam diu**, *as long as*. — **necessario**, *unavoidably*; **coactus**, *on compulsion* (being forced).

CHAP. 18. **pluribus præsentibus** (abl. abs.), *in the presence of several*. — **jactari**, *bandied about* (freq. of **jacio**). — **Liscum retinet**, [but] *keeps Liscus*. The omission of the conjunction (*asyndeton*) is very common in Cæsar's rapid narrative.

2. **ex solo**, *from him apart*. — **secreto** (**secerno**), *each by himself*. — **summa audacia**, [a man] *of the utmost boldness*.

3. **portoria**, *customs-dues*, levied at the frontier, collected (apparently) as by the Romans through *publicani*, who bid for the contract at public auction. The other *vectigalia*, farmed out for collection in the same way, were tithes on farm produce, rent of public pastures, &c. — **redempta**, agreeing with *vectigalia*, and taken with **habere**, *had bought in* (see Chap. 15<sup>1</sup>). — **illo licente**, *when he bid*.

4. **ad largiendum**, *for gifts*, to buy political support.

**12. largiter posse**, had extensive power. — **causā**, for the sake: as always when thus following a genitive. — **potentiae**, power, as an attribute of the person: *potestas* is power to do anything; *facultas*, opportunity; *imperium*, military authority. — **Biturigibus**, near the modern Bourges. — **ex matre**, on the mother's side (a half-sister). — **collocasse**, had contracted in marriage (**nuptum**).

**5. favere . . . Helvetiis** (dat.), he favored and wished well to the Helvetians. — **adfinitem**, family alliance. — **suo nomine**, on his own account (a mercantile phrase applying to business debts, &c.).

**6. si quid accidat** (a mild phrase), in case of any disaster. — **imperio** (abl. of time and cause), under the rule.

**7. quod . . . factum**, a kind of adverbial phrase = in regard to the unsuccessful cavalry skirmish fought the other day.

CHAP. 19. **res**, facts. — **accederent**, were added: **accedo**, approach, is used as a kind of passive of **addo**. — **inter eos**, i.e. the Helvetii and Sequani. — **injussu suo**, &c., without his authority (see § 71. b; G. 76. B; H. 134) or that of the state: here **suo** is equivalent to a genitive. — **inscientibus ipsis**, without his own knowledge or that of the Ædui. **magistratu**: Liscus was *vergobret*. — **in eum animadverteret**; should proceed against or punish him (see vocab.).

**2. quod . . . cognoverat**, that he well knew, &c. (the present inceptive, **cognosco**, having the meaning to learn). This clause, in apposition with **unum**, might in English be introduced by some such word as *namely*. — **studium**, attachment as partisan; **voluntatem**, good will as friend. — **supplicio**, punishment or execution. This word is derived from the adjective **supplex**, down-bent, signifying on the bended knee; i.e. either as a suppliant for mercy, or (as here) to receive the blow of the executioner.

**3. prius quam conaretur**, before he should attempt; see § 327; G. 579; H. 520. — **per** connects **Procillum** with **colloquitur**. — **principem**, a leading man. — **cui**, &c.: an easier construction would be *cujus fidei omnes res credebat*; **summam fidem**, full confidence.

**13. commonefācit**, warns or notifies (see vocab.). — **ipso**, i.e. Divitiacus. — **apud se**, in his (Cæsar's) presence. — **offensione animi**, displeasure (of Divitiacus); **ipse**, which follows, refers to

Cæsar: he hopes, in what steps he takes or orders to be taken against Dumnorix, not to incur the resentment of his brother.

CHAP. 20. **ne quid gravius** (a common phrase), *no severe measures*. Notice that **gravius** is an adjective. What does it modify?

2. **scire se**, &c., "I know," said he, "that this is true, and no one can be more pained at it than I." — **plus doloris**: except as an adverb, this comparative is mostly used, as here, with the partitive genitive. — **capere** [Et. 33]. — **ipse se, suam, sese**, all refer to Divitiacus; **ille** to Dumnorix, which is also the subject of **crevisset** and **uteretur**. — **opibus ac nervis** = *sinevis of power*, obj. of **uteretur**. — **gratiam**, as well as **perniciem**, takes **suam**. — **amore fraterno** (§ 190. *b*; G. 363. R.; H. 395. N.<sup>2</sup>), *love to his brother*.

3. **si quid accidisset** = *if anything should happen* (a Euphemism); plup. representing fut. perf. ind. (**acciderit**) by sequence of tenses: a future condition (§ 307. *f*; G. 659; H. 525. 2). — **futurum [esse] uti . . . averterentur** (periphrastic future infin., § 147. *c*. 288. *f*; G. 240; H. 537. 3), *the heart of all Gaul would be turned from him*.

4. **rogat [ut] faciat**, see § 331. *f*. R.; G. 546. R.<sup>3</sup>; H. 499. 2. — **tanti**, *of so great account* (§ 252. *a*; G. 379; H. 405). — **condonet**: "Cæsar pretended to yield to the prayers of the Druid, but in fact he yielded to necessity. He was in great straits, with a warlike enemy in front and doubtful allies around him, on whom his army was dependent for food" (Long: compare Bk. v. Chap. 6).

**praeterita** [Et. 493], *things bygone* ("the past"). — **Dumnorigi ponit** (= **adponit**), *sets over him*. — **custodes**, *spies*.

CHAP. 21. **qualis esset**, &c., indir. question after **cognoscerent**. — **natura**, *character*; **qualis . . . ascensus** = *the chance of ascending it* [what kind of an ascent there was] *at* [various points of] *its circuit*. — **qui cognoscerent** (§ 317; G. 632; H. 497. 1): the antecedent of **qui** is **quosdam**, or some such word, as object of **misit**, *he sent men to ascertain*.

2. **facilem**, sc. **ascensum**. — **pro praetore**, *with powers of prætor*. The prætor, like the consul, held the *imperium* or power to command; a *legatus*, not possessing this in his own right, might be temporarily invested with it by his commander. Labienus, and

perhaps others of Cæsar's lieutenants, had the *imperium* in their own right, by special grant.

**14. ducibus** (pred.), *as guides*. — **qui . . . cognoverant**, i.e. of the party of reconnoissance — **consilii**, part. gen. limiting **quid**. — **de quarta vigilia**, about 2 A.M., the sun at this season rising here about 4 o'clock. — **contendit**, *pushed on*.

3. **Sullae, Crassi**: Sulla (the dictator) had conducted the war against Mithridates about 30 years before (B.C. 88-84), and Crassus that against Spartacus some years later (B.C. 71). — **captivos**: Et. 33.

CHAP. 22. **aut Labieni**, or *Labienus's*: this predicate use of the genitive is rare in Latin. — **equo admisso** = *at full speed* (with reins thrown loose).

2. **insignibus**, i.e. *devices* on shields and helmets, — stags' horns, eagles' plumes, &c., — the origin of modern heraldry. The inference from this report would be that Labienus had been cut to pieces, and Cæsar must expect an attack at once. This accounts for his next movement, which was to fall back and wait in line of battle, while Labienus was vainly expecting him.

3. **ut, as**. — **ne . . . committeret . . . essent**, subject of **erat praeceptum**. — **ut . . . fieret**, *so that the attack might be made on all sides at once*. — **monte occupato**, &c., *having seized the height, continued to look out for our men*.

4. **multo die** (loc. abl.), *late in the day*. — **quod non vidisset**, *what he had not seen*, sc. **id**, obj. of **renuntiasset**. — **pro viso**, *as if seen* (**viso** is used here as a noun). — **quo**, sc. **eodem**, *at the same interval as usual*; **mīlia** (acc.), § 257. *b*; G. 335; H. 379.

CHAP. 23. **diei**, § 214. *g*; G. 371. *R*.<sup>4</sup>; H. 398. 5. — **omnino**, *in all (only)*. — **supererat**: Et. 459. — **cum** = *within which*. — **Bibracte**, the modern *Mont Beauvray*, a considerable hill, about 10 miles west of *Autun* (Augustodunum). — **rei frumentariae** (dat.), *the supply of corn*.

2. **fugitivos**, *runaways*. The regular word would be **transfugas**: the term which generally means fugitive slaves is here

applied, contemptuously, to deserters from the cavalry of the Gallic allies.

**decurionis**: the auxiliary cavalry (the entire cavalry force) was divided into *alae*, or battalions, consisting each of 10 *turmae*, or troops, and these again into three *decuriae*, of probably 10 men, each originally commanded by a *decurio*. In Cæsar's time, however, the *decurio* commanded the *turma*. Æmilius was the senior officer.



Fig. 6. *Eques*.

3 *eo magis* (abl. of difference), *all the more*.

— *locis*, &c., *though holding higher ground*. — **occupatis**: Et. 33.

**15. eo quod . . . confiderent** (abl. of cause), *for this reason because they felt sure that they (the Romans) could be cut off from their supplies*.

**itinere converso**: the fatal step which led to their complete destruction.

The Helvetians were now well in advance of Cæsar, and might probably have continued their march unmolested to the coast, had not their vain confidence turned them back. Cæsar's army was at this time not far from 60,000 men, including about 20,000 auxiliaries, mostly "Gaulish mountaineers"; so that he was a full match, in a fair field, for the Helvetians, who had now about 70,000 fighting men.

CHAP. 24. **animum advertit** (= **vertit animum ad**: usually written as one word, **animadvertit**): *to turn the mind upon any thing is to notice it*; hence this phrase takes a direct object (**id**) like a single transitive verb. — **qui sustineret** = *to sustain* (§ 317. R.; G. 544; H. 497. 1).

2. **in colle medio**, *half way up the hill*. — **triplicem aciem** (Et. 2), &c. — *four veteran legions in triple line*. — **in summo jugo**, i.e.



on the level top of the hill. — **ac** = *and thus*. — **sarcinas**, *packs* (personal baggage). — **eum**, *this* [place]. — **his qui**, &c., *those who stood* (had taken their stand) *in the upper* (i.e. *rear*) *ranks*: these were the two new legions, opposed to **veteranarum**, above.

THE ORDER OF BATTLE. — The favorite position of the Romans, the *locus superior*, was a hillside, not too steep, with the enemy below. The line of battle was formed across the slope, and here the Romans awaited the attack. If at the foot of the hill there was a morass, a stream, or other obstacle likely to confuse the hostile ranks, it was so much the better.

In the triple order of battle, the first line contained four cohorts, and each of the others contained three (see Fig. 28). Between each cohort and the next one in the same line was left an interval equal in extent to the front of a cohort. Behind these intervals in the first and second lines were placed the cohorts of the second and third lines respectively. The distance from the rear of either line to the front of the one behind it was also equal to the front of a cohort. We may consider the front of a cohort in battle array to have been (on an average) about 120 ft. in extent, and the depth to have been 40 ft. Then 1 legion extended 840 ft. in front and 600 ft. in depth; and the entire front of Cæsar's line of battle of 4 legions, including the intervals between the legions, was 3720 ft., or about  $\frac{3}{4}$  of a mile.

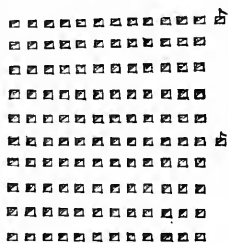
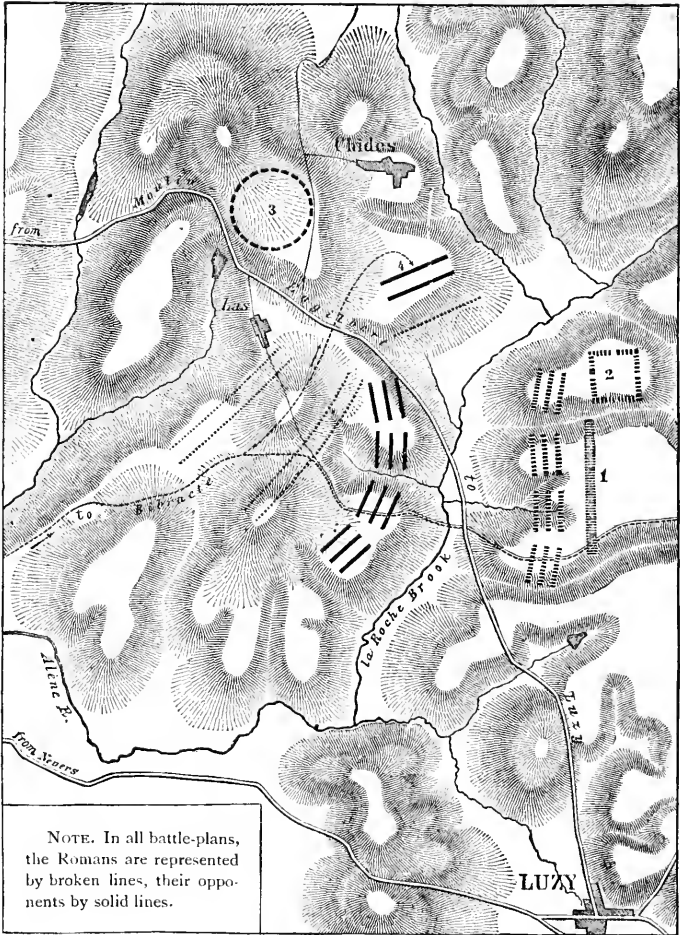

Fig. 7. The Manipular Legion.

As the 3 maniples of a cohort were placed side by side, the front of each would occupy 40 ft. Allowing 4 ft. for the interval between the maniples, in which interval stood the centurions, and 3 ft. room for each man, the manipule would consist of 12 files. The distance from breast to breast in the files was quite likely 4 ft. Thus the file would contain 10 men, and the manipule would form a square of 40 ft. on a side. The first 5 ranks formed the first *ordo* (or century), and the remainder were the second. The first centurion stood at the right of the front rank of the first *ordo*, and the second centurion had a like station in the second.

When the enemy had reached the right distance, the bugle sounded the charge, and the legions rushed down hill to meet them, sword in sheath, and the first two ranks with spears uplifted (*pilis infestis*) ready to hurl.



**Plan II. Battle with the Helvetians.** Bk. I. Ch. 24-26.

- |                                     |                                     |
|-------------------------------------|-------------------------------------|
| 1. The new legions and auxiliaries. | 3. The Helvetians' baggage, parked. |
| 2. Cæsar's camp.                    | 4. The Boii and Tulingi.            |

The heavy lines show the first position of the two armies. The mountain to which the Helvetians fled lies immediately west of the modern village of *Las*. Just south of that village, the light dotted lines show the position of the Helvetians at their second attack, and, facing them, the second position of the first two lines of the Romans. The third line has wheeled to the right, to meet the flank attack of the Boii and Tulingi.

When within 25 to 50 ft. of the opposing phalanx, the two ranks hurled their heavy spears in a shower, and immediately drew their short swords and charged fiercely upon the disordered mass of the foe. The odd numbers of the front rank sprang forward to gain room (3 ft. would answer for marching or for using the spears, but at least 6 ft. would be required to give space enough for the swords). The even numbers and the entire second rank followed as a support.

Along the front of the cohort exists now a series of single combats. The third, fourth, and fifth ranks press close up, to aid their comrades and to take the place of any that fall, and meanwhile throw their spears over the heads of the combatants among the throng of the enemy behind. The remaining five ranks of the cohort follow slowly, as a reserve.

In the meantime the second line is advancing, and, if the enemy do not at once give way, the first line is withdrawn, and the cohorts of the second rush through the intervals and attack with spear and sword. The wearied first line is now occupied in re-forming and getting breath for a new onset, which is made after a lapse of from ten to fifteen minutes.

We see that we must imagine the legion in battle as in almost constant motion. The two lines are hurled successively against the enemy, giving the latter no rest, and wearing them out by the incessant blows of the cohorts. The third line, however, is held in reserve, and is only brought into action in case the other two prove insufficient to cause the enemy to break.

The cavalry are drawn up in the rear or on the flanks of the army, ready, should the hostile array be broken and routed, to plunge into the flying mass and cut them to pieces.

**THE GALLIC ARRAY AND ARMS.**—The Macedonian phalanx had a front of about 500 men and a depth of 16. That of the Gauls and Germans was doubtless of similar form, but of varying numbers. The men stood close together, forming a compact mass. The shields of the front rank formed a vertical wall, and those of the rest were held overhead, lapping over one another like the shingles on a roof, only in the reverse order. It will be seen that the phalanx depended for its success on the momentum of its mass. However, only those on its outer edges could use their weapons, while the rest were practically imprisoned in the crowd. Here the Romans had a great advantage; for, from their open and pliable order of battle, nearly every man sooner or later was in action. Hence, although they might be greatly inferior in number, they could bring into use more swords and spears at a given point than could their enemies.

The Gallic sword was very long, two-edged, and sheathed in an iron scabbard that was suspended at the right side by an iron or bronze chain. This sword had no point, and hence was adapted rather for cutting than thrusting. The spear had a blade at least 2 ft. long and 6 to 8 in. wide, sometimes of an undulated form. As missile weapons, light javelins, bows and slings were used. The helmet was of metal, adorned with the horns of animals, having a crest representing a bird or savage beast, and surmounted by a high and bushy plume of feathers. The shield was of plank, at least 5 ft. long, and very narrow. The body was guarded besides by an iron or bronze breastplate, or by a coat of mail. This last was a Gallic invention.

CHAP. 25. **suo** [equo], *having sent back his own and all the others' horses*. This was often done before an engagement (cf. Sall. Cat. 59). He is reported to have said to his men, "I will mount again when the enemy run."

2. **impedimento**, dat. of service, § 233; G. 350; H. 390.—**pluribus**, *several*. For the whole of this description, compare what is said above of the form of this javelin and the close order of the phalanx.—**evellere**, *pull them out*.—**sinistra impedita** (parenthesis), *since the left hand was shackled*.—**multi ut**, *many* [to such a degree] *that*.—**nudo**, *unprotected*.

3. **pedem referre**, *fall back*: not *retreat*, which would be **terga vertere**.—**mille**, acc. of distance, the idea of distance being implied in **suberat**.

4. **agmen claudebant**, *brought up their rear*. The Boii or Tulingi, with about 15,000 men, had been in front of the Helvetian line of march, and were consequently in the rear when they faced round to attack Cæsar. They now struck at his exposed right flank (**latere aperto**) as they came on the field from the road (**ex itinere**).

16. **conversa signa intulerunt**, *faced about* (lit. "bore their reversed ensigns upon" the enemy), *and charged in two divisions*. The divisions stood not back to back, but at an angle, facing outward; the two front lines facing forward, while the third met the flank attack of the new-comers (*venientes*). The phrase *conversa signa* refers only to the movement of the third line, while *intulerunt* denotes the action of the entire army.

THE MILITARY STANDARDS. — The term *signa* (*signa militaria*), in a general sense, applied to all the standards of the army. That of the legion was an eagle (*aquila*), usually of silver, about the size of a dove, and carried on the top of a wooden staff. The staff was shod with iron so that it might be thrust into the ground. Often it was adorned with a *vexillum*, a little flag, or banner, suspended from a cross-bar at the top. The *vexillum* was red or white, and was inscribed with the number or name of the legion. The eagle was intrusted to the first cohort, and especially to the care of its oldest centurion. Its bearer (*aquilifer*) was a soldier selected for his courage and fidelity.

Fig. 8. *Aquila*.

The standard of the cohort was the *signum*, in the narrower sense of that word. It was usually the figure of an animal — a wolf or sheep, for instance — on a staff. Its bearer was the *signifer*. *Vexilla* were also carried on the flanks of the maniples to mark the alignment, performing the same office as “guidons” in a modern battalion. Thus there must have been at least four *vexilla* in a cohort, — perhaps eight, if each century required them for its alignment.

Fig. 9. *Vexillum*.

The cavalry and light troops and all separate detachments (see Bk. VI. Chap. 36) carried only the *vexillum*. Its bearer was called *vexillarius*. There was another standard called *vexillum*, the flag of the general. This was a large banner, white, with an inscription in red letters giving the general's name, that of his army, &c. It was placed near the headquarters tent in the camp, and when displayed was the signal for march or battle (see Bk. II. Chap. 20).

Fig. 10. *Signum*.

CHAP. 26. *ancipiti*, *two-headed*, thus facing two ways at once. — *alteri*, the Helvetians; *alteri*, the Boii, &c.

2. *ab hora septima*, i.e. from a little past 1 P.M.; sunset was

about eight, so that each of the twelve daylight hours was about an

hour and a quarter of our time. — **aversum hostem** = *an enemy's back*. — **ad multam noctem**, *till late in the night*. — **pro vallo**, *as a barricade*. — **e loco superiore**, *from vantage-ground*, i.e. the height of the carts, &c. — **coniciebant, subiciebant**, *hurled* (from above), *thrust* (from below). For the form of these words, see § 10. *d*; H. 36. 4 [Et. 493]. The semi-vowel *j* is lost before *i*: therefore in most dictionaries look for **conji- cio, subjicio**. — **mataras**, heavy Gallic pikes, thrown from the hand; **tragulas**, light javelins, used by Gauls and Spaniards.

4. **Lingōnum**, i.e. the southern part of *Champagne*, towards the north. — **propter**, &c., gives the reason of **morati**.

5. **Lingonas**, Greek form of the accusative (§ 63. *f*, & 64; G. 73; H. 68), com-



Fig. 11. *Aquilifer*.

mon in these names of tribes. — **qui si juvissent** = *for if they should*, &c. — **eodem loco habiturum**, *would hold on the same footing*. — **sequi**: Et. 497.

In the year 1860, numerous burial mounds near the place of this battle (in which considerably more than 100,000 human beings must have perished) were opened, and found to contain skeletons buried face downward, with knives, bracelets, rings, and hair-pins of bronze, very similar to the

relics discovered shortly before in the lake-dwellings of Switzerland. It has been conjectured that these lake-dwellings were among those destroyed at the time of the Helvetian migration (see De Sauley, *Campaigns of Cæsar in Gaul*).

CHAP. 27. **qui . . . paruerunt**; observe the change of subject in this sentence, from **legati** to **Cæsar**, as well as the change of mood with the same subject, **convenissent, paruerunt**. The syntax will present no difficulty. — **projecissent**; Et. 493.

2. **qui per fugissent**, fugitive slaves from the Province. — **conquiruntur, conferuntur**: to express the passive in English, it is often better to use the active form, *while they are hunting these up and bringing them together*. — **nocte intermissa**, *when the night was past*: i.e. it was then ascertained what had happened early in the evening. — **Verbigenus**, from the parts between Berne and Lucerne.

17. **occultari**, *be hid* from Cæsar; **ignorari**, *unknown* to anybody. — **contenderunt ad**, *made (rapidly) for*.

CHAP. 28. **quorum**: the antecedent is **his** (dat.) following **imperavit**, the direct object of which is **uti . . . reducerent**. — **sibi** (dat. of reference), *in his eyes* — **reductos . . . habuit**, *when brought back, he treated them as enemies*, i.e. massacred them all: the phrase is regularly used in this signification.

**in deditionem accepit**: by this act they became formally the subjects of the Republic, and were entitled to its protection, as well as required to obey its requisitions and pay tribute.

2. **reverti**, *turn back* (from a march or journey; **redire**, *go back*, from a place of rest). — **fructibus = frugibus** (which is found in some copies), grain and other field produce. — **tolerarent**: Et. 195. — **copiam facerent**, *provide a supply*. — **ipsos**, the Helvetians.

3. **ea ratione**, *with this view*. — **Allobrogibus**: these were within the Province.

4. **petentibus Haeduis**, *to the Ædui, at their request*: dat. after **concessit**, of which the object is, **ut Boios collocarent**. (**Boios** is put first in the sentence for emphasis.) — **parem atque ipsi erant** = *equal with themselves* (§ 156. a<sup>2</sup>; G. 646; H. 451. 5). — **juris**: Et. 125. — **condicionem**: for the form of this word, see § 12. a.

CHAP. 29. *tabulae*, *tablets*, of the shape of a folding slate, with wax spread inside, written on with a pointed instrument called *stilus*.

*litteris Graecis*; not in the Greek *language*, but in Greek *letters*. These were probably learned from colonists at Marseilles, as the Gauls had no alphabet of their own. Specimens of Gallic names on coins are in the names DUBNOREX, ΔIVICIACOS, VERCINGETORIXS. — *relatae*: Et. 195. — *ratio*, *an estimate*, followed by the indir. question *qui . . . exisset*. — *confectae*, *made out*.

2. *capitum* [Et. 52], "*souls*." — *ad milia xcii.*, *about 92,000*.

3. *summa*, *the sum*: *fuerunt* agreeing with the plural predicate. Deducting the Boii, who were adopted by the Ædui, this reckoning would show an actual loss, in slain or captives (slaves), in this short campaign, of about 250,000, including probably about 150,000 women and children, or other non-combatants.

GERMAN CAMPAIGN.—The latter half of this Book is taken up with the expulsion of a military settlement of Germans, which had been made a few years before, under Ariovistus, a chief of the Suevi.

The occasion of this new campaign was the following. The Ædui, jealous of the Sequani, who lived a little to the north, had laid excessive tolls on their trade, which consisted chiefly in the export of salted meats for the southern market.\* This led to a war, in which the Sequani had invited the aid of the Germans under Ariovistus, about three years before the campaign of Cæsar. The Germans, once in Gaul, had exacted a large share of territory, and proved to be grasping and oppressive masters. Meanwhile the Helvetian war began to threaten. The Roman Senate, to make safe, passed the decrees before mentioned, promising favor and friendship to the Ædui (Chap. 11); and at the same time sent messengers to Ariovistus, saluting him as king and friend (Chap. 35), recognizing his claims on Gaul, and (it was said) inviting him to Rome. This was the year before, in Cæsar's consulship. Now, however, that the fear of the Helvetians was passed, Cæsar found himself obliged to take sides in the old quarrel.

18. CHAP. 30. *principes*: Et. 33; *intellegere*: id. 440. — *populi Romani*, *against*, &c. (obj. gen. after *injuriis*). — *ab his repetisset*, *had inflicted on them* (see Chap. 12<sup>4</sup>). — *ex usu*, *to the advantage*.

\* "From this region," says Strabo, "the best of pickled pork is sent to Rome" (iv. p. 192).



2. **eo consilio**, with this design, explained by the purpose-clause **uti . . . haberent**. — **florentissimis rebus**, i.e. with no plea of necessity. — **domicilio**, for habitation. — **ex magna copia** = from a wide choice, implied in **quem . . . judicassent**. — **stipendiarias, tributary**: *stipendium* is the tax paid by a subject community.

3. **uti sibi liceret**, that it might be allowed them. — **concilium totius Galliae**: of course Cæsar had no authority to allow or prohibit a congress of independent Gaul. But, considering his power and ambition, they thought it best to secure his countenance (**voluntate**, not **auctoritate**) beforehand. They also had business that specially concerned him. — **petere**: Et. 173.

4. **jurejurando sanxerunt**, ordained under oath [of secrecy]: the object is **ne quis**, &c. — **enuntiaret**, inform of the proceedings. — **nisi quibus**, &c., except [to those] to whom some commission should be assigned (pluperf. for fut. perf.).

CHAP. 31. **eo concilio dimisso**, i.e. when this assembly had been held and dissolved, after providing for the business now described. — **idem (iidem)**, nom. plural. — **secreto**, apart; **in occulto**, in a secret place.

2. **Caesari**, dat. of reference (see § 235. a; G. 343. R.<sup>2</sup>; H. 384. 4. N.<sup>2</sup>) = at Cæsar's feet. — **id** (in apposition with **ne . . . enuntiantur**) **contendere**, &c., they no less urgently desired their account to be kept secret than to obtain the thing they sought (ind. disc. **dixissent**, for fut. perf. of direct).

3. **factiones duas**, see note, Chap. 3<sup>3</sup>. — **principatum**, leadership. — **Arvernos**: these inhabited the mountainous country southwest of the Ædui, the modern *Auvergne*. — **factum esse uti**, it came to pass that, &c. — **Sequanis**: these were the rivals of the Ædui on the north.

4. **feri ac barbari**: as to the condition of the Germans, see introduction. — **adamassent** (= *adamavissent*, § 128. a; G. 191<sup>5</sup>; H. 235), had become attached. — **horum** (emph.), of the latter. — **copias** (= *opes*), resources. — **plures**, notice the emphasis, also in **nunc**.

19. 5. **clientes**, the subject states of the Ambarri, Segusiavi, &c. — **omnem . . . equitatum**, of course an exaggeration: *Divitia-*

cus was himself a noble, probably a senator; while his brother Dumnorix was a commander of the Ædúan cavalry.

6. **qui . . . potuissent**, [they] *who had once, &c., were compelled.* — **repetituros**, *demand back.* — **quo minus**, following a verb of refusing (§ 317. b; G. 547; H. 497. II. 2), seems originally to have been a phrase of courtesy, implying a less point-blank refusal than **ne** or **quin**. — **dicione**, i.e. to do their bidding.

7. **potuerit**, in direct discourse **potuit**, the perfect having a tendency to remain in the perfect (subjunctive), contrary to the rule.

**juraret**: Et. 125. — **Romam venisse**, see note, Chap. 3. His application was not successful. See Bk. VI. Chap. 12.

8. **pejus accidisse**, *a worse thing had befallen.* Observe that a misfortune is usually said **accidere**, as if it fell on one, while a good thing is said **evenire**. — **Ariovistus**, supposed to be the German word *Heerfürst*, "prince of the host."

**tertiam partem**, i.e. upper *Alsace*, a part of the German conquest of 1870. This was the same proportion of conquered land taken by the German invaders (*Burgundians*) in this very territory in the fifth century of the Christian era. It seems to have been the ancient common law of conquest (Liv. ii. 41). — **optimus**: this district (*Franche Comté*) is one of the most beautiful in France, and the "best wooded." The chief export was dried meat and hams. — **nunc . . . juberet**: so too the *Burgundians*. — **juberet**, in direct disc., **jubet**, *he bids.* — **quibus . . . pararentur** = *to be provided with a place for habitation* (subj. of purpose). — **venissent**: Et. 509.

9. **futurum esse uti** (periphrastic future), *the result would be.* — **neque enim** introduces an explanation admitting no doubt. — **hanc = nostram** (§ 102. a; G. 290; H. 450), said with some feeling of superiority or contempt.

10. **autem**, *again*, a slight antithesis between the king and the things mentioned before. — **ut . . . vicerit**, indir. disc. for **ut vicit** (§ 324; G. 563; H. 471. 4), *once conquered.* — **Magetobriam**, a little west of *Vesontio* (*Besançon*). — **in eos . . . edere**, *gave forth* (i.e. *wreaked*) *all sorts of torments on them* (observe the *hendiadys*).

11. **barbarum**, &c., *rude, passionate, and hasty.* — **nisi si** (see § 315. a; G. 592; H. 507. 3. N.<sup>4</sup>), &c., *unless they find some aid.*

**20.** *idem*, in appos. with *ut . . . experiantur*. — *ut emigrant*, that is, to forsake their home.

12. *haec*, notice the emphasis. — *quin sumat*, that he will inflict upon (§ 332. *g.* R.; G. 551. 2; H. 501. II. 2); lit. take a penalty of. — *Rhenum*, acc. after *trans* in *traducatur* (§ 239. *b*; G. 330. R.<sup>1</sup>; H. 372).

CHAP. 32. *oratione*: Et. 459. — *habita*, having been spoken (the usual word). — *magno*: Et. 387. — *unos*, alone. This whole scene is "most illustrative of the Gallic character."

2. *quae esset*, indir. question after *miratus*. — *respondere*, historical infinitive.

3. *hoc*, in this respect. — *solī*, they alone. — *ne . . . quidem*, not even secretly. — *absentis* (pred.), even when absent. — *crudelitatem*, obj. of *horrent* (§ 177. *c*; G. 329. R.<sup>1</sup>; H. 371. III. N.<sup>1</sup>). — *tamen*, after all, whatever they might have to suffer. — *Sequanis*, dat. of agent with *perferendi* (§ 232; G. 353; H. 388), the *Sequani* must endure (changing the voice).

CHAP. 33. *sibi curae* (dat. of service, § 233; G. 350; H. 390), a care to him. — *et . . . et*, construe after *adductum*, induced by both . . . and.

2. *secundum*, in accordance with: lit. following (§ 153; G. 417; H. 433). — *quare putaret*, indir. question, following *hortabantur*. — *Haeduos*, obj. of *videbat* and subj. of *teneri* (below).

**21.** *appellatos* (pred.), who had been often called. — *quod*: the antecedent is the preceding clause *Haeduos . . . Sequanos*.

3. *periculosum*, pred., agreeing with *Germanos consuescere*, &c., he saw it was dangerous to the Roman people for the Germans, little by little, to get in the way of crossing the Rhine, &c. — *sibi temperaturos quin exirent*, would check themselves [refrain] from going forth. — *ut*, as; *fecissent* being subjunctive as dependent on *exirent*, § 342 (R. 47); G. 666; H. 529. II. N. I. 1; *Cimbri Teutonique*: these German tribes had been crushed by Marius (B.C. 102, 101), after having been for several years a terror upon the Italian frontier.

4. *Rhodanus* = only the Rhone. — *rebus*, dat. following *occurrentum* [*sibi*], § 228 (R. 18); G. 346; H. 386: which things he

*thought must be met at once.* — **tantos spiritus, such temper.** — **non ferendus, unendurable.**

CHAP. 34. **ab eo, of him** (§ 239. c. R.; G. 333. R.<sup>2</sup>; H. 374. N.<sup>3</sup>). — **medium utriusque, between the two.** — **conloquio** (dat.), *for a conference.* — **de republica agere, to treat on public business** [Et. 104].

2. **si quid, &c., if he needed anything from Cæsar.** — **opus:** § 243. e. R.; G. 390; H. 414. iv. N.<sup>4</sup>; **ipsi, dat. of poss.** (§ 231; G. 390; H. 387). Observe in this sentence that the reflexives **ipse** and **se** refer to Ariovistus (§ 195. k; G. 521. R.<sup>8</sup>; H. 452. 5), and the demonstratives **is, ille, to Cæsar.** — **se velit, wants of him:** the secondary accus. is in analogy with that after verbs of asking. The acc. of neuter pronouns is often used with intransitive verbs or as a second object.

4. **mirum quid . . . esset, a sort of indir. question: it seemed strange to him what business, &c.** — **in sua Gallia, in HIS** [part of] *Gaul.* — **negotii, part. gen. with quid** (§ 216. a<sup>3</sup>; G. 371; H. 397. 3).

CHAP. 35. **tanto . . . adfectus, distinguished by so great favor, &c.** (see note before Chap. 30): **beneficio** is explained by **cum . . . esset, and gratiam referret by ut . . . putaret;** the first **sibi** refers to Cæsar and the second to Ariovistus. In this sentence the causal clause is **quoniam . . . putaret,** and the leading verb is **esse:** *Since, though so greatly favored by the Romans, he made such an [ill] return (hanc gratiam referret) as to grudge coming to a conference when invited, and did not consider that he ought to speak or hear about the common business, [therefore] these were the demands he made (the things he required) of him, &c.* Observe that in Latin the significant word is the *verb*; in English the *noun*. “Ariovistus knew as well as any one how much gratitude he owed to Rome for these *beneficia*.”

22. 2. **ne quam, not any.** — **voluntate, consent.** — **ejus** refers to Ariovistus, and **illis** to the Sequani.

3. **si non impetraret, if he (Cæsar) should not get** [this pledge]. — **Messala, &c., i.e. B.C. 61. M. Messala, &c., simply in the consulship, &c., only to indicate the year.** — **obtineret, should hold** (as governor). — **censuisset, had voted.** — **quod = so far as.** —

**commodo** (abl. of specif.) **reipublicae**, to the advantage of the state. — **defenderet**: see the reasons, in the note referred to above. — **se**, a repetition of **sese** above, to bring it nearer to its verb. — **neglecturum**: Et. 440.

CHAP. 36. **jus**, a right. — **vicissent** for **vicerint** (fut. perf.), following **ut**. — **iis**, obj. of **imperarent**: that those who conquer shall rule those they conquer as (**quem ad modum**) they will. The verbs are in the past by sequence of tenses (§§ 285, 287. d; G. 518; H. 495. iv.). — **item**, in like manner. — **victis**, obj. of **imperare**. — **alterius**, any one's else. — **arbitrium**: Et. 509; **praescriberet**: id. 122.

3. **sibi stipendarios**, tributary to himself. — **qui faceret** = in making (§ 320. e; G. 636; H. 517).

4. **non . . . neque**: [on the one hand] he would not restore, &c., but [on the other] he would not wrongfully (**injuriam**), &c. — **convenisset** = had been agreed. — **longe . . . afuturum**, the name of brothers would be a great way off from them, i.e. too far to help them.

5. **quod**, &c., the whole clause is construed as an adverbial accusative: as to *Cæsar's* threat, &c. — **secum, sua**, observe that these refer one to Ariovistus, the other to his antagonist. — **congrederetur** (for **imperat.**), he might come on when he would; he would know, &c. — **inter** refers to something coming between two extremes. Hence, when applied to time, it means the entire interval between the beginning and the end of a given period, and may be rendered *during*. — **quid possent**, what their strength was.

CHAP. 37. **eodem tempore, et** = at the same time [when] this message, &c.

**23. Treveris**, from the region of *Trèves* in the valley of the Moselle. — **questum**, to complain (supine). — **qui . . . essent**, who (they said) had just come over (§ 341. a; G. 509; H. 524).

2. **ne . . . datis**, not even by giving hostages. — **pagos** (see note, Chap. 12<sup>4</sup>): these divisions were those known as *hundreds*, meaning not only the people, but the district they occupied (see Bk. iv. Chap. 1).

3. **maturandum sibi**, that he must hasten. — **minus facile**, not

*very easy*: i.e. would be *impossible*; but this would be a word of ill omen.

**resisti** (impers., § 230; G. 208; H. 384. 5) **posset**, *they could not be so easily resisted*. — **ad**, *towards*. — **contendit**: Et. 186.

CHAP. 38. **viam**, § 257; G. 335; H. 379. — **Vesontionem**, the modern *Besançon*, about ninety miles E. N. E. of the former battle-ground. — **quod** relates to **Vesontionem**, but agrees in gender with **oppidum**: § 199; G. 616. 3. II.; H. 445. 4. — **profecisse**, *had advanced*.

2. **ne**, following **praecavendum** (§ 331. *e*; G. 548; H. 497. II.). — **facultas** = *facility for obtaining*, hence, *supply* (see note, Chap. 31<sup>8</sup>). — **daret**: Et. 225. — **Dubis**, the modern *Doubs*. This name is said to mean “black river”; or, in the form *Alduasdubis*, “river of black rocks.” — **ut**, *as it were*.

3. **spatium**, obj. of **continet**. — **pedum**, pred. gen. after **est**; for construction with **amplius**, see § 247. *c*; G. 311. R.<sup>1</sup>; H. 417. N.<sup>2</sup>. — **qua**, *where*. — **riparae**, nom., subj. of **contingant**. The real distance is 1600 feet. — **hunc** [montem]: *this an encompassing wall makes into a fortress*. Some remains of this wall are yet to be seen.

4. **circumdatus**: Et. 225. — **occupato**, *taken possession of*.

CHAP. 39. **percontatione**, *questions*. — **vocibus**, *talk*. — **ingenti**: Et. 112; **magnitudine**: Et. 387. — **praedicabant**, *represented*.

**24. saepenumero**, *oftentimes*. Adverbs are frequently thus strengthened by a qualifying word, usually a genitive: as *hic loci*, &c. — **congressos**, *having met them*. — **occupavit**, *seized*.

2. **hic**, i.e. **timor**. — **ortus**: Et. 414. — **reliquis**, i.e. aids or *attachés* (*contubernales*, *comites*), who attended the governor or commander of a province for the sake of military practice. All these were often appointed from mere personal or political motives, and were of small use in the service, as it proved here. This staff was sometimes called, irregularly, the *praetorian cohort*. — **amicitiae causa**: Cæsar's earlier career had been that of a political adventurer. He was deeply in debt, and probably could not afford to refuse positions to the “poor relations” of his creditors, trusting the valor of his veterans to cover their short-comings. It will be

observed that the politic proconsul represents these worthies as having come *out of friendship* for himself. — *alius aliā causā, on various pretexts* (§ 203. c; G. 306; H. 459. c). — *quam diceret, which, they said* (§ 341. d. R.; G. 539. R.; H. 503. 1).

3. *vultum fingere, put on a brave face* (*vultum* refers to the *expression* of the face). — *abditū, hiding*. — *testamenta obsignabantur*, indicating utter despair. The word refers to a will, sealed and witnessed in due form, — not the mere informal declaration permitted to soldiers on the eve of battle (*in procinctu*).

4. *in castris = in military life*. — *rem frumentariam . . . timere* (accus. of anticipation: § 334. c; G. 470; Madvig, 439. Obs. 1), *feared [for] the supply of corn, lest it might not be conveniently brought in* (§ 331. f; G. 552; H. 498. III.).

5. *cum jussisset, for cum jusseris* (fut. perf.) of direct disc. — *castra moveri, to break camp*. — *dicto audientes, obedient to the word of command*. — *signa laturos, would carry the standards, i.e. advance*. This is the technical term, as the standards were planted in the ground during a halt.

CHAP. 40. *convocato*: Et. 496. — *omnium ordinum, of all classes*. See below. — *incusavit*: Et. 60. — *sibi quaerendum . . . putarent, thought they had a right to inquire* (it ought to be inquired) *or have any idea* (it ought to be thought), in agreement with the interrog. clause *quam . . . ducerentur*. •

#### RELATIVE RANK OF THE CENTURIONS.

There were ten classes (*ordines*) of centurions in the legion, those of each cohort composing one class, and ranking in the order of the cohorts. The six centurions of the first cohort, then, were the *centuriones primorum ordinum*; those of the second cohort, *secundorum ordinum*, &c.\* Usually, only those of the first class were summoned to the council of war. But this was a full council of all the officers, as Cæsar desired to make as wide an impression as possible through the army.

Göler thinks that the first class comprised the first centurions from all the cohorts, &c.; thus making six classes of ten in each class. But Cæsar mentions an *eighth* class (B. C. III., 53). So Göler is obliged to assume that the subcenturions (*optiones*) were considered centurions, thus making six more classes.

\* Rüstow, Heerwesen und Kriegführung C. Julius Cæsars, pp. 7-12.

We may observe, on this point, that it seemed the uniform policy of the Romans that the *cohorts*, as well as the officers, should differ in rank, in order that the most experienced and skillful men might form the first line, and those of less experience the last. For the same reason, the best centurions would be needed in the first line, i.e. in the first four cohorts. The passage in Vegetius,\* II. 21, we interpret as follows:—

As vacancies occurred in the ranks of any cohort, they were filled by detailing the best men from the next lower cohort. Thus recruits would always fall to the tenth cohort, and the first cohort would contain the very flower of the legion. Hence, under ordinary circumstances, when it became necessary to appoint a centurion, selection would be made from the privates of the first cohort (presumably from its first maniple), and he would be assigned as a centurion of the tenth cohort. Then he would pass successively through the grades of that cohort, then through the grades of the ninth, and so on, until he became first centurion of the first cohort (*primipilus*). Thus the circle (*orbem*) of service would be complete.

As to the *optiones*, each centurion seems to have selected his own, as the word implies, and as is expressly stated by Varro, Festus, and Paulus Diaconus. This choice would be impossible if they were graded as Göler supposes.

2. **se consule** (direct, **me consule**), *in his consulship*. — **cur quisquam judicaret**, *why should any one think?* For the form of question, see § 338. R.; G. 654. R.<sup>2</sup>; H. 523. II. N.; (direct, **judicet**, *dubij. subj.*); for the use of **quisquam**, implying a negative, see § 105. *h*; G. 304; H. 457. — **tam temere discessurum**, *would fall away so hastily*. — **sibi persuaderi**, *for his part he was persuaded* (*mihi persuadetur*, § 230; G. 208; H. 301. 1): the subject of **persuaderi** is **eum . . . repudiaturum**. — **perspecta**: Et. 99.

25. 3. **quod si intulisset**, *but if he should*, &c. (dir. disc. intulerit, fut. perf. ind.) — **quid tandem**, *what, pray, were they afraid of?* — **sua**, *their own*; **ipsius**, *his*: **ipse**, used in this way, to avoid the repetition of **sua**, is an *indirect reflexive*.

4. **periculum** (root in **experior**), *a trial*. — **Cimbris**, &c., A.D. 102 and 101, a little more than forty years before. — **cum** . . .

\* Nam quasi in orbem quemdam per diversas cohortes et diversas scholas milites promoventur, ita ut ex prima cohorte ad gradum quempiam promotus vadat ad decimam cohortem; et rursus ab ea, crescentibus stipendiis, cum majore gradu per alias recurrit ad primam.



**videbatur**: although this clause was a part of Cæsar's speech to his officers, yet the indicative is used to emphasize to the reader the *reality* of the fact it asserts (§ 336. *b*; H. 529. N.<sup>1</sup> 2)). It will be noticed that **cum** is here equivalent to **et tum**, and the apparent temporal clause is actually coördinate with the preceding infinitive. This is the only instance in the Commentaries of an imperfect indicative with **cum**. — **meritus**, sc. **esse**. — **servili tumultu** (abl. of time), the insurrection of the slaves (gladiators) under Spartacus, B.C. 73–71. These consisted largely of the Germans captured by Marius. A war at home, i.e. in Italy or on its borders, was called *tumultus* (see Cic. Phil. viii. 1). — **quos** (referring to **servos** implied in **servili**) . . . **sublevarent** (changing to passive so as to keep the emphasis), *who yet were considerably helped by the training and discipline which they had got from us*. — **aliquid**, adverbial accusative.

5. **quantum boni**, *how much advantage* (§ 189. *a*; G. 195. R.<sup>2</sup>; H. 397. 3), *firmness has* (for the tense of **haberet**, see § 287. *d*; H. 495. v.) — **inermos**, i.e. the slaves of Spartacus's force. — **quos** . . . **hos**: notice the relative as usual preceding the antecedent.

6. **hos esse**, the Germans with Ariovistus. — **quibuscum congressi**, &c. (changing the relative clause), *whom they had often met and beaten on their own ground* (as well as, &c.). — **qui**, i.e. the Helvetii. — **tamen**, i.e. though they were strong enough to beat the Germans, *after all*, &c. — **potuerint**, see § 287. *c*. R.; G. 513; H. 495. VI. and foot-note 2.

7. **adversum proelium**, see Chap. 31<sup>b</sup>. — **si quos** . . . **commoveret**, *if any were alarmed by* (lit. if the disastrous battle moved any). — **Ariovistum**, subj. of **vicisse**. — **neque** . . . **fecisset**, *and had given them no chance at him*. — **adortum**, agrees with **Ariovistum** and governs [eos] **desperantes**.

8. **cui rationi**, &c.: **cui** relates to **hac** (*ratione*), the noun being attracted to the relative clause, as is frequent in Latin (§ 200. *c*; G. 618; H. 445. 9): *by a stratagem for which there had been room against unskilled barbarians, not even Ariovistus himself hoped that our armies could be taken in*.

9. **qui** . . . **conferrent**, [as for those] *who laid their own cowardice to the pretended difficulty about provisions*, &c. — **desperare**, &c., *to be discouraged about the commander's doing his duty*. —

praescribere, sc. officium; i.e. that they were dictating to him *what his duty was*.

10. **frumentum**, *grain*. — **subministrare**, *were* [now] *furnishing*. — **esse**, *were beginning to be*. — **frumenta**, *crops*.

11. **quod . . . dicantur** (see § 330. b; G. 528; H. 534. I. N.<sup>1</sup>): *as to its being said that they would not*, &c. — **nihil**, *noway*. — **quibuscumque**, dat. after **audiens dicto**: i.e. no one has ever had a mutinous army, who has not either been unsuccessful by his own fault, so that his men had no confidence in his ability; or been convicted of avarice by some overt act, so that they had no confidence in his integrity. — **suam**, *his own*, emphatic by position; equivalent to *in his case*. — **innocentiam**: the technical word, meaning freedom from the charge of plunder and extortion. In fact, Cæsar's fault lay just the other way, — a lavish and reckless generosity at the expense of subjects or allies. (In this sentence, in chiasitic order, **innocentiam** is opposed to **avaritiam**, and **felicitem** to **male re gesta**; a peculiarly Latin turn.)

26. 12. **quod . . . fuisset**, *what he had intended to defer*. — **repraesentaturum**, *he will do at once*. This is a legal term, meaning *to do a thing before the time*. One who pays money before it is due is said *solutionem repraesentare*.

13. **decima legione**: this was the legion which had been stationed in the province of Gallia Transalpina; it was distinguished for discipline and courage. — **praetoriam cohortem** = *body-guard*, the correct use of the term: compare note, Chap. 39<sup>2</sup>.

This celebrated speech of Cæsar to his men, though in what seems to us the awkward and cold form of indirect discourse, is an admirable model of military eloquence, and deserves attentive study.

CHAP. 41. **innata est**, *sprang up*. — **optimum iudicium fecisset**, *had expressed the most favorable opinion* (a technical phrase).

2. **cum tribunis . . . egerunt**, &c., *urged upon the tribunes to apologize*. — **summa belli** = *the policy of the campaign*. — **suum . . . sed imperatoris**, predicates after **esse** (§ 214. c; G. 365; H. 402).

3. **satisfactione**, *apology* (compare **satisfacerent**, above). — **accepta**: Et. 33. — **ei**, *in him*. — **ut . . . duceret** (result), depends

upon **itinere exquisito**. The subject of **duceret** refers to **itinere**. Also, cf. note on **rem**, Chap. 39<sup>4</sup>. Lit., *the road having been learned that it led*; i.e. *it having been learned that the road led*. — **milium** [passuum] limits **circuitu**, *by a circuit of more than fifty miles*. — **locis apertis**, *through the open country*, so as to avoid a return of the panic.

4. **exploratoribus**, *scouts*. See note on Bk. II. Chap. 5, "Camp Duties." — **a nostris**, *from ours* (i.e. forces).

CHAP. 42. **per se**, *so far as he was concerned* (a common expression with **licet**).

2. **respuit**: Et. 318. — **reverti**, *that he was beginning to return*. — **petenti** [Caesari], *when he asked it*. — **veniebat**, *began to come*. — **fore uti desisteret** (periphrastic future following **spem**), *that he would cease from his stubbornness*.

27. 3. **ultra citroque**, *hither and yon* (lit. *beyond and this side*). — **veniret for veniat** (hortatory) of direct discourse. — **alia ratione**, *on any other terms*.

4. **interpositā causā** (abl. abs.), *by putting in an excuse*. (Notice that *excuse* has the same root as **causa**.) — **Gallorum equitatu**: he had no other; see note, Chap. 23<sup>2</sup>. — **Gallis equitibus**, dative following **detractis** (§ 229; G. 346; H. 385. II. 2). — **eo**, *upon them* (= **iis**, § 207. a). — **si quid**, &c., *if there should be need of any active measures*: **quid** is adverbial acc. (§ 240. a; G. 331. R.<sup>2</sup>; H. 378); **facto** (§ 243. e; G. 390; H. 414. N.<sup>3</sup>).

5. **quod cum fieret**, *while this was going on*. — **ad equum rescribere**, *he enrolled them among the knights*. The word *equites* means not only the cavalry service in war, but a special privileged class in Roman politics. It seems that Cæsar could appreciate a pun. — **rescribere**: Et. 122.

CHAP. 43. **tumulus terrenus** = *a smooth* (i.e. not rocky) *hill*. — **satis grandis**, *pretty large*. — **aberat**: Et. 459.

2. **equis**, *on horseback*. — **passibus ducentis** (abl. of distance, or degree of difference) = 320 yards. — **constituit**: Et. 175. — **denos**, *ten on each side*.

3. **beneficia**, *favours*. — **munera**: according to Livy (xxx. 15), the gifts sent to Masinissa were "a golden crown and bowl, a curule

chair, an ivory staff, an embroidered toga, and a tunic with palm-leaf figures" (worn in triumphal processions). — **pro . . . tribui**, *was usually granted only in return for special services*. — **docebat**, *informed*. — **aditum**, *access*. — **ea præmia consecutum**, *had attained these prizes*, as if he had eagerly sought them (compare introductory note to Chap. 30). The tone of Cæsar's speech shows his intention of affronting the pride of Ariovistus.

4. **necessitudinis**, *alliance*. — **ipsis** (to avoid the use of **sibi**, which might refer to Cæsar alone), the Romans. — **intercederent**, *existed between*. — **senatus consulta**, properly, *orders* [executive] of the Senate, which had no authority to pass laws. — **ut**, *how*.

## 28. appetissent: Et. 173.

5. **sui nihil**, *nothing of their own* (dignity, &c.). — **quod . . . adtulissent**, *what they had brought to the alliance*; i.e. the independence and dignity which they had possessed. — **posset**, § 338. R. last part; G. 654. R.<sup>1</sup>; H. 523. II. 1. N.

6. **postulavit eadem** = *he made the same demands*. — **in mandatis**, *in their instructions*. — **at**, *at least*.

CHAP. 44. **rogatum et arcessitum** = *at the request and summons*.

2. **sibi**, *on him* (referring to the main subject).

3. **pace uti**, *enjoy peace*. — **sua voluntate**, *by their own consent*. — **oportere**, impersonal: its subject is **amicitiam . . . esse**. — **id**, not **eam**, because it refers to the idea, **ut amicus populi Romani esset**.

4. **per**, *through the action of*. — **si remittatur**, future cond. (§§ 307, 337; G. 659; H. 507. 1, 527. 1): the pres. for imperf. for greater vividness. — **subtrahantur**, *are got away* (by underhand means). — **non minus libenter**, *with no less pleasure*.

5. **quod . . . traducat**, *as for his bringing over* (the **quod** clause of fact, made subj. by indir. disc.). — **defenderit**, *had defended himself against*.

29. 7. **hanc Galliam**, *this part of Gaul*. — **ut . . . sic**, *as . . . so*. — **ipsi**, used as an *indirect reflexive*. See note on Chap. 40<sup>3</sup>.

8. **quod** = *in that*. — **imperitum rerum**, *ignorant of affairs*. — **sciret**: Et. 45. — **bello proximo**, i.e. B.C. 62.

9. **debere se suspicari**, &c., *he had ground to suspect, that Cæsar, in keeping an army in Gaul, kept it with pretence of friendship, [but really] for the sake of ruining him.* — **exercitum**: Et. 3.

10. **nobilibus gratum**, *a favor to the nobles.* Cæsar was the recognized head of the party opposed to the Senate and nobility. Many of the aristocracy would have been glad of any safe way to be rid of him. See Cic. Fam. viii. 1, for the way rumors of disaster to Cæsar were spread among his enemies in Rome. — **id comperit habere**, *had ascertained* (§ 292. c; G. 230; H. 388. I. N.).

The three relatives **qui** (l. 15), **quod** (l. 17), and **quod** (l. 21), illustrate the principle that the relative, serving to connect with the previous proposition, may represent various conjunctions: — *if then he should not withdraw* (**qui = is igitur**); *and if he should kill him* (**quod**, adverbial accusative, *and as to this*); *but if he should withdraw* (**quod = sed**, &c.).

CHAP. 45. **in eam sententiam quare** = *to this effect* [to show] *why.* — **negotio**, *enterprise.* — **desistere**: Et. 175. — **neque se judicare**, *and he did not consider.*

2. **bello superato**, B.C. 121, when the Allobroges were subdued, and the Province (probably) organized. — **ignovisset**, *had pardoned*: in fact, their country lay beyond the naturally strong frontier of the Cevennes.

3. **antiquissimum quodque** (see § 93. c; G. 305; H. 458. 1). Cæsar, referring to the statement of Ariovistus in Chap. 44<sup>6</sup>, claims priority of conquest for the Romans. — **spectari**: Et. 99.

### 30. CHAP. 46. **conloquio**: Et. 77.

3. **periculo legionis**, *danger to the legion.* — **committendum non ut dici posset** = *no ground should be given for saying* (§ 332. c; G. 557; H. 501. 1). — **per fidem**, *through* [misplaced] *trust.*

4. **elatum est**, *it was reported.* — **qua adrogantia usus**, *with what display of insolence.* — **omni Gallia** (abl. of separation, with **interdixisset**, § 243; G. 388; H. 413), *had ordered the Romans* (dat. following **inter-**) *away from all Gaul.* — **ut**, *how* (indir. question).

CHAP. 47. **uti constitueret**, following **velle** (§ 331. b; G. 546; H. 498. 1). — **si minus**, *if not.*

2. **conloquendi**: Et. 77. — **retineri quin**, *be kept from* (§ 319.

*d*; G. 550; H. 504. 4). — **poterant**; **potuerant** would be expected. — **legatum e suis** = *one of his own* [officers] as an envoy. — **magno . . . missurum**, *it would be at great risk that*, &c.

3. **Flacco**, governor of Gaul B.C. 83. It was customary for slaves or aliens to become clients of the person from whom they received freedom or citizenship; and to take his *gentile* name (§ 80. *a*; H. 649). Thus here Procillus takes the name (C. Valerius) of his patron Flaccus, retaining his own as *cognomen*. — **civitate donatus erat** (§ 225. *d*; G. 348; H. 384. II. 2). — **quā multā . . . utebatur**, *which Ariovistus spoke freely*. — **peccandi causa**, *ground of offence*. — **hospitio**: the relation of **hospes**, existing between two persons of different cities or nations, made a sacred bond far closer than that of simple *hospitality* (see vocab).

4. **referrent**: Et. 344.

**31. CHAP. 48. promovit**: Et. 379. — **a Caesaris castris**. This camp is placed by Napoleon III. at the southern foot of the *Vosges* mountains, a few miles N.W. of Mühlhausen, just at the point where there is a break between the *Vosges* and the spurs of the *Jura*, opening from the valley of the *Saône* into that of the *Rhine*. The reversed march of *Ariovistus* placed him just in this passage, so as to cut off *Cæsar's* supplies. This pass is now commanded by the famous fortress of *Belfort*.

3. **hoc**, pointing to the description which follows. — **genus**: Et. 112; **exercuerant**: Et. 3.

4. **singuli** [equites] **singulos** [pedites], *one apiece*. — **versabantur**, *acted*.

5. **circumsistebant**: Et. 175. — **si quo . . . prodeundum**, *if there was occasion*, &c. (**quo** = *to any place*). — **exercitatione**. *through training*. — **sublevati**, *supporting themselves*. — **cursum adaequant**, *keep pace with them*.

Tacitus (*Germania* 6) says: "They fight in combination [infantry and cavalry] and the foot soldiers, picked out of the entire body of young men and placed in front of the line, are able to keep up with the cavalry in speed."

**CHAP. 49. castris** (loc. abl.), *in camp*. — **consederant**: Et. 234. — **acie triplici**, see Chap. 24<sup>2</sup>.

2. **secundam**: Et. 497. — **castra munire**, to fortify the camp. The Roman camp was measured with great precision by certain fixed rules (based on the science of augury), and thoroughly fortified with earth-wall, ditch and palisades. The spade was as familiar to the Roman soldier as the sword or javelin. In this case, Cæsar had one larger camp about two miles north of the Germans, and a smaller one rather more than half a mile to the west of them.

#### THE CAMP.

1. The Roman army in hostile or doubtful territory encamped at the close of each day's march on ground carefully selected and as carefully fortified. When possible, the site was the slope of a gentle hill, so that the front had before it still a portion of the descent, and the rear lay on the summit. Thus line of battle could be formed before the camp in the favorite Roman position (*in loco superiore* \*). Then, too, water must be at hand, and abundant wood. Of course these conditions could not always be fulfilled, and sometimes the camp must be pitched where necessity demanded (*in loco necessario*).

2. The right-angled quadrilateral was in Cæsar's time probably the only form of the Roman camp (Fig. 15). It was either square, or with sides in the ratio of 3 to 2. The corners were rounded, so as to afford room for defence. The gates (*portae*), one on each side, were usually merely openings, probably as wide as the front of a maniple (40 ft.). They were defended by semi-circular *tambours*, or by a traverse (*titulum*) reaching to a corresponding distance (see Fig. 15). Very likely on the inside was a corresponding traverse.

3. The normal Roman fortification consisted of a wall (*agger, vallum*) on which the defenders placed themselves †; and before it a ditch (*fossa*), from which came most of the material for the wall, and which stopped the approach of the enemy at the distance of a good spear-cast. The width of the ditch at the top was always a number divisible by 3 ‡, and the depth was  $\frac{2}{3}$  of this width, plus 1. We may notice that Cæsar usually gives but one dimension of the ditch, the other, of course, being understood. The usual width was 9 ft., and the depth was 7 ft. There were three forms: that with both scarp and counterscarp sloping (*fossa fastigata*); the *fossa punica*, with sloping scarp and vertical counterscarp; and the ditch with both scarp (*latus interius*) and counterscarp (*latus exterius*) vertical

\* Bk. I. 24, II. 5. 8. 24, III. 19. † Bk. V. 39. ‡ Bk. II. 5, VII. 27. 72. The only exception will be found in the chapter last referred to.

(*directis lateribus* \*). The first form was the most common. In this the width at the bottom was  $\frac{1}{3}$  that at the top.

4. We think of a wall mainly as a breastwork behind which soldiers are sheltered from the fire of the enemy. But it was quite different with the Romans. They had comparatively little need for shelter from missiles. What they aimed at mainly was a high position, inaccessible to the enemy, from which to hurl their spears. The section of such a wall we may consider practically a rectangle, of sufficient height and width. The width should be enough for standing firmly, and for moving backward and forwards to hurl the javelins. The height should be as great as possible. Of course this would be limited by the fact that the earth came from the ditch. The usual height seems to have been  $\frac{2}{3}$  of the upper width of the ditch. *Cæsar* often speaks of a ditch 15 ft. wide, and a wall of 10 ft. The outer slope of the wall could be made very steep, as there was no fire of cannons to withstand. But to keep the earth of the wall in place, there had

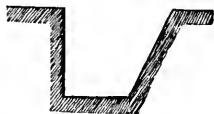

Fig. 12.  
*Fossa Punica.*



Fig. 13.  
*Fossa directis lateribus.*

to be a facing of some more tenacious material. For this purpose there were used sods cut in digging the ditch; also timber and brush. This last was put up in bundles, in the form that we call *fascines*. Vegetius says that the Romans cut sods  $1\frac{1}{2}$  ft. long, 1 ft. wide, and  $\frac{1}{2}$  ft. thick, for use in fortifications. With such sods cut from the ditch,  $\frac{1}{2}$  the height of the wall could be faced, leaving the other half to be strengthened with sod cut elsewhere, or with fascines.

5. The Romans were not always content with this facing of the outer slope. When they sought to give the wall especial height, they made it firmer by embedding in it several lines of fascines parallel to the length.

6. The rampart, of course, should be easily mounted from the inside. For this purpose steps were made. These were of brush, or at least strengthened with brush.

7. It is clear, then, that a Roman camp needed much wood, and also that the section of the wall was greater than the section of the ditch. The vertical section of a wall 6 ft. in height and width, well faced, and provided

\* Bk. VII. 72.



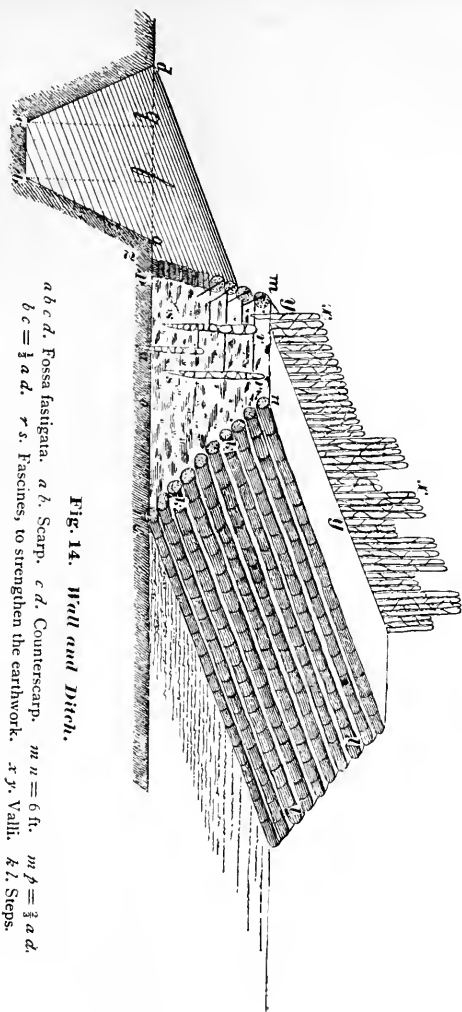

Fig. 14. Wall and Ditch.

*a b c d.* Fossa fastigata. *a b.* Scarp. *c d.* Counterscarp. *m n* = 6 ft. *m p* =  $\frac{3}{4}$  *a d.*  
*b c* =  $\frac{1}{2}$  *a d.* *x s.* Fascines, to strengthen the earthwork. *x y.* Valli. *k l.* Steps.

with steps, contains about 56 sq. ft. The ditch (*fossa fastigata*) 9 ft. wide and 7 ft. deep, has a section of 42 sq. ft. But the earth would loosen itself about  $\frac{1}{2}$  in digging. That gives 49 sq. ft. section for the earthwork, leaving 7 sq. ft. for brushwork. Of this, at least 6 sq. ft. must be allotted to the steps.

8. When the wall was wide enough, on its top was placed a breastwork (*lorica, lorricula*) of stakes (*valli\**). On these a few twigs were left, which were firmly bound together. This breastwork was either of a uniform height of 4 or 5 ft., so that the soldiers could easily see over it and cast their spears; or there were pinnacles (*pinnae*) placed on it, 2 or 3 ft. high, between which were gaps. There were often erected on the wall, from point to point, wooden towers. † At such places both wall and ditch had to be wider.

9. It has been explained that the camp was generally a square, or a rectangle whose sides were as 3 to 2. The *front* was the side towards the enemy, or towards which on the following day the march would be taken up. The *rear* was of course opposite, and the other two sides were right and left to one facing the front.

10. The depth of the camp was divided into three nearly equal parts.

\* Bk. V. 40, VII. 72.

† Bk. V. 40, VII. 72, VIII. 9.

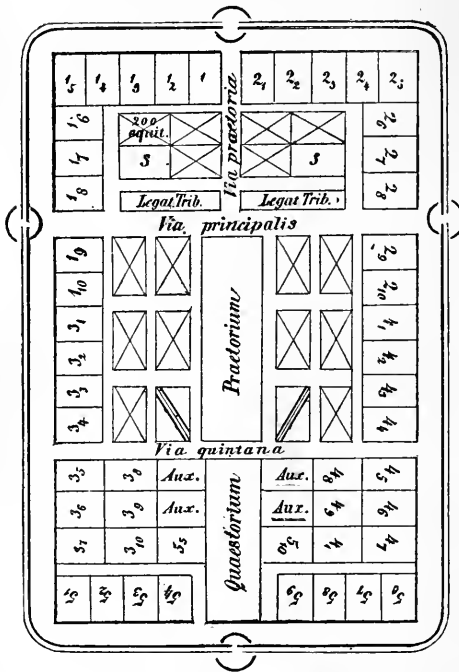

Fig. 15. *Castra Romana*.

the enemy, or towards which on the following day the march would be taken up. The *rear* was of course opposite, and the other two sides were right and left to one facing the front.

10. The depth of the camp was divided into three nearly equal parts.

\* Bk. V. 40, VII. 72.

† Bk. V. 40, VII. 72, VIII. 9.

Beginning at the front, they were the *praetentura*, the *latera praetorii*, and the *retentura*. These three divisions were made by two broad streets parallel to the front, the *via principalis* and the *via quintana*.

Fig. 16. Fortifying the Camp.



The former ended at each side of the camp with a gate, the *porta principalis dextra* and the *porta principalis sinistra*. Very likely in large camps there were gates at the ends of the *via quintana* also.

11. In the middle of the front wall was the *porta praetoria*, and opposite, in the rear wall, was the *porta decumana*.

12. From the *porta praetoria* to the *via principalis* extended a street, the *via praetoria*. Opposite this, in the middle part of the camp, was the *praetorium*, a wide space in which were the headquarters tents, the altars, and the tribunal. This space occupied in length all the middle of the camp, but extended only 100 or 150 ft. each side of the middle line.

13. In the *retentura* was a similar place, the *quaestorium*. Here were the quarters of the administrative staff, here hostages and prisoners were kept and forage and booty were placed.

14. Outside of the camp, back of the *porta decumana*, were the booths of the sutlers (*mercatores*) who followed the army.

15. In the *praetentura* were stationed from  $\frac{1}{4}$  to  $\frac{1}{5}$  of the cohorts, equally divided between the two sides.\* They occupied the tents facing the wall. Also in the *praetentura*, along the *via principalis*, was the place for the tents of the *legati* and *tribuni militum*. Again, in each half of the *praetentura*, in the space enclosed by the cohorts along the wall, by the tents of the *legati* and *tribuni* and by the *via principalis*, were encamped  $\frac{1}{4}$  of the cavalry and  $\frac{1}{2}$  of the archers and slingers. Thus in the entire *praetentura* were quartered  $\frac{1}{2}$  of the cavalry and all the archers and slingers, ready to march from the front gate and form the advanced guard.

16. On each flank of the *mid camp*, next the wall, was a line of cohorts,  $\frac{1}{10}$  of the entire number in the army. Thus  $\frac{1}{5}$  of the cohorts were here quartered. Next the *praetorium*, along both its longer sides, were placed the staff, except, of course, the *legati* and *tribuni*. Along the *via principalis*, between the cohorts along the wall and the staff, were encamped on each side  $\frac{1}{4}$  of the cavalry, or  $\frac{1}{2}$  in the whole *mid-camp*.

17. In the rear part of the camp, on each side of the *quaestorium* and equally divided by it, lay the rest of the cohorts, about  $\frac{1}{2}$  of all in the army. They faced the wall on the flanks and rear. Enclosed by the cavalry, by the *quaestorium*, and by the *via quintana*, was the place for the auxiliary infantry, excepting the archers and slingers.

18. Entirely around the camp, within the wall, extended a broad street. This would at once prevent the likelihood of hostile missiles reaching the tents, and would allow room for moving troops to defend the walls. The width of this street is variously estimated. It was probably over 100 ft.

19. In the spaces behind the tents the arms were stacked and the pack animals tethered.

\* For the arrangement of the cohorts in camp, see note on Bk. II. Chap. 5.

20. In estimating the time needed for fortifying the camp, we may consider the normal measure of the ditch to be 9 ft. wide and 7 ft. deep. Some of the men were detailed to the ditch, some to the wall, and others to gather material and make fascines. Those allotted to the ditch would probably work in three reliefs, each being occupied not more than an hour. A skillful digger who works only one hour and is then relieved, can easily excavate in that time from 50 to 60 cu. ft. (Roman). But the Roman legionaries were above all things skillful at digging. Then 3 or 4 hours would suffice completely to fortify the camp. Meanwhile others would be busied in laying out the streets and setting up the tents. So if the work was begun at noon, by 4 o'clock all would be finished.

**32.** CHAP. 50. *instituto suo, according to his previous practice.* — *potestatem fecit, gave an opportunity.*

3. *inlatis et acceptis, after giving and receiving.*

4. *matres familiae*: according to Tacitus (Ger. 8), it was not matrons only, but women as a class, or most of them, to whom this prophetic power was ascribed. — *sortibus, lots of leaves or twigs marked with certain signs and drawn by chance*; *vaticinationibus, omens interpreted from the noise of waters, river-eddies, &c.* — *declararent*: Et. 58. — *ex usu, expedient.* — *utrum . . . necne, § 211*; G. 460; H. 353. — *non esse fas, it was not the divine will.* — *novam lunam* (cf. Tac. G. 11): so the Spartans refused to advance to Marathon before the full moon.

CHAP. 51. *reliquit*: Et. 500. — *alarios*: the auxiliaries as distinguished from the legionary (Roman) troops. They were usually stationed on the wings of the line of battle; hence their name, from *ala, a wing.* — *quod minus valebat, because he was weak in comparison with the enemy.* — *ad speciem, to make a show, as if the two legions were still there, while in fact they had joined the other force at the greater camp.* — *acie, of legionaries alone.*

2. *generatim, by tribes or clans.* — *Marcomannos, "men of the Mark," or frontier.* It became a very formidable name about 200 years later, in the region of Bohemia and Bavaria.

3. *eo, thereon, i.e. among the carts and wagons.* — *proficiscentes, [the men] as they advanced* (obj. of *implorabant*). — *traderent*: Et. 225.

**33.** CHAP. 52. **singulos legatos**, a *legatus* in command of each legion. This was the beginning of a very important reform in the military organization. Cæsar felt so keenly the evil of the command being divided among six tribunes, that he detailed one of his *legati* nominally to assist the tribunes. After this time, we find the *legatus* as the regular commander of a legion, with the six tribunes under him. On this occasion he appointed his quartermaster (*quaestor*) to that one of the six legions which was intended to be under his own special command. — **praefecit**: Et. 256.

2. **ita . . . ut, so . . . that.** — **spatium**, room, i.e. time. — **rejectis**, throwing aside.

3. **impetus**: Et. 173. — **in phalangas** (acc. plur. § 63. f. 64; H. 68, 98. N. 2), upon the *phalanxes*. These were compact bodies of 300 to 400 men each with shields close locked in front and above (see note on Chap. 24). — **revellerent**, &c., i.e. they leaped upon the roof of shields, pulled them up, and so thrust their swords down from above (**desuper**).

4. **a sinistro cornu**, on their left wing.

5. **P. Crassus**, son of Marcus Crassus the triumvir. — **adulescens**, to distinguish him from his father. — **expeditior**, more disengaged. — **versabantur**, were engaged.

CHAP. 53. **restitutum est**, contrasted with **laborantibus**, above. — **Rhenum**: the nearest point was a little below Bâle, somewhat more than five miles distant. Some texts have **quinque** instead of **quinquaginta**. The latter seems to be the correct reading, however. The Germans fled down the valley of the *Ill* (see dotted line in Plan III.), reaching the Rhine near *Rheinau*, some 50 miles from the battle-field. — **fugere**: Et. 142. — **pervenerant**: Et. 509.

2. **tranare contenderunt** = by great effort swam across. — **reliquos omnes**, said to be 80,000.

3. **duae uxores**: only chiefs among the Germans, says Tacitus (G. 18), had more than one wife; and this was for the sake of honor and alliances. — **Sueva**, see Bk. iv. Chap. 1. — **utraque perierunt**: for Cæsar's massacres of women and children, compare Bk. IV. Chap. 14, Bk. VII. Chap. 28.

4. **Procillus**, see Chap. 47<sup>3</sup>. — **trinis catenis**, three [sets of] manacles. — **in Caesarem incidit**, happened on Cæsar himself.

**34.** 5. neque . . . deminuerat, nor had Fortune, by any harm to him, &c.

6. se praesente, in his own presence. — ter: it was the regular usage of the Germans to consult the lot thrice (Tac. G. 10). This has come down to the present day in sundry games, &c.

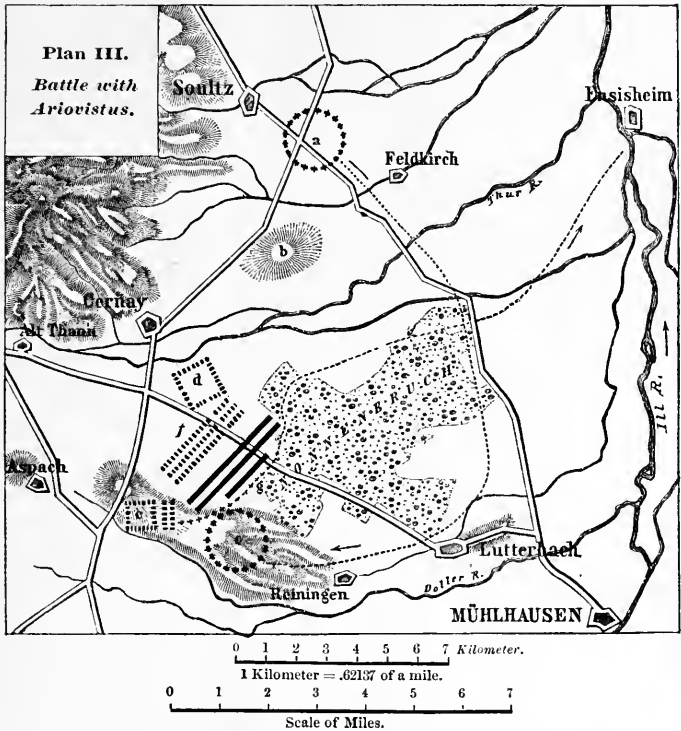

a. First camp of Ariovistus.

b. Hill on which the conference was held.

c. Second camp of Ariovistus.

g. German line of battle.

d. Caesar's larger camp.

e. Caesar's smaller camp.

f. Roman line of battle.

**CHAP. 54. Ubi** (some older editions have **ubi**): these lived near the modern *Cologne*, and were deadly enemies of the Suevi, and

therefore generally in alliance with the Romans (Bk. IV. Chap. 3).

14. **maturius**, *earlier*; the decisive battle with Ariovistus was fought about the 10th of September.

16. **in citeriorem Galliam**, south of the Alps. — **conventus**: the proconsular Courts held for the administration of justice.

THE LEGIONS. — When Cæsar came to Geneva, in the spring of the year 58 B.C., he found only one legion stationed in the farther province (Chap. 7<sup>2</sup>). This was the 10th (Legio X), afterwards so distinguished for fidelity and courage. As soon as the Helvetians set out through the territory of the Sequani, Cæsar hastened to Hither Gaul, enrolled two new legions (XI and XII), and called from their winter quarters the three (VII, VIII, and IX) that were stationed in that province (see Chap. 10<sup>8</sup>). It was these six legions, together with auxiliaries (both horse and foot), that composed the army with which the Helvetians and the Germans were conquered.



### BOOK SECOND. — B.C. 57.

THE BELGIAN CONFEDERACY. — The people of Northern Gaul, including Flanders and the Netherlands, were far remote from any country hitherto occupied by the Roman arms. They lived amid forests and swamps hard to penetrate; they claimed kindred with the German tribes rather than with the more fickle and effeminate Celts; and they had a fierce and resolute spirit of independence, like that which the Dutch exhibited long after in the same regions, against the armies of Spain.\* The Belgian tribes, and particularly the Nervii, appear in this confederation to have offered to Cæsar a more formidable and desperate resistance than any he met elsewhere, until the great rising of B.C. 52; and when their spirit was once broken, the conquest of Gaul was simply a question of time.

NOTE. — Learners who begin the study of Cæsar with the Second Book are especially referred, in the preceding Notes, to the *general directions* (p. 5) and the *military notes*; viz.: on the Roman Soldier (p. 3), the Legion (p. 17), the March (p. 23), the Order of Battle (p. 35), and the Standard (p. 39). They should also study in the Synopsis the outline of the Helvetian and German campaigns, so as to understand the military situation at the opening of this second year. The attention of teachers is called to the Appendix, pp. 120, 121.

\* A very striking account of the country and its inhabitants will be found in the introduction to Motley's Dutch Republic.



PAGE

**35.** CHAP. I. *cum esset, while C. was:* subj. with **cum** temporal (§ 325; G. 586; H. 521. II. 2). The verb comes in this emphatic place on account of the close connection of these words with the preceding book (see Appendix). — **cit. Gallia**, Northern Italy; see “Life of Cæsar,” p. xv. — **in hibernis** (an expression rarely used except of an army): Cæsar was not with any army, and the phrase is probably interpolated. — **ita uti** (= **ut, as**), correl. (§ 107; G. 556. R.<sup>5</sup>; H. 305). — **adferebantur, certior fiebat** (observe the imperf. of *repeated action*, § 227; G. 222; H. 49) = *kept coming in; was informed from time to time*. — **litteris, by despatches:** abl. of means, § 248 (compare § 246. *b*); G. 403; H. 420. — **Belgas . . . conjurare . . . dare, that the Belgians, &c.:** ind. disc., accus. and infin. following the verbal phrase **certior fiebat** (§ 272; G. 527; H. 535). Direct: **Belgae conjurant**. — **quam** agrees with **partem** (§ 199; G. 616. R.<sup>3</sup> II.; H. 445<sup>4</sup>), though the logical antecedent is **Belgas**. — **esse:** indir. disc. (with subj. acc. **quam**), obj. of **dixeramus**. — **dixeramus** is in the indic., because, though a rel. clause, it is parenthetical merely, and not a part of the report of Labienus (§ 336. *b*; G. 630. R. 1; H. 524. 2. 1). — **demonstravimus, dixeramus:** the perfect here implies an act done before the time of writing (see end of Bk. I.); the pluperfect, what took place before the time of **demonstravimus**. The Romans were very precise in indicating the relation of actions to one another in point of *time*. An act completed or to be completed before another begins, is almost invariably expressed by a tense of completed action. In this respect the English is less exact. — **conjurare:** “any war against Rome is a ‘conspiracy’; a nation enslaved by Rome is ‘pacified.’” — **inter se, to one another:** § 196. *f*; G. 212; H. 448. N.

2. **conjurandi**, gerund (§ 298; G. 429; H. 542. I.). — **has esse causas:** the report of Labienus, continued (indir. disc.). — **quod vererentur, sollicitarentur:** subjunc. because subord. clause in indir. disc. (§ 336; G. 541; H. 524). — **Galliã**, i.e. Celtic Gaul (§ 310. *a*; G. 670; H. 549. 2), within which the previous campaigns had been conducted. — **exercitus noster**, i.e. to hold them as a conquered province. — **ne . . . adduceretur:** subst. clause, obj. of **vererentur** (§ 331. *f*; G. 552; H. 498. III.). — **ab nonnullis Gallis:** § 246; G. 403; H. 415. I. — **partim qui, &c.**, is an explanatory remark added by Cæsar; hence the indic. The Gauls, by whom

the Belgians were instigated (**sollicitarentur**) are here divided into three classes: (1) **qui . . . ferebant**, those now jealous of the Roman power, as they had been of the German; (2) **qui . . . studebant**, the restless, who soon tired of any settled rule; (3) those who held (or hoped to get) despotic authority. — **ut . . . ita**, correls. (§ 107; G. 556. R.<sup>5</sup>; H. 305). — **Germanos . . . versari**: obj. of **noluerant** (§§ 271. a, 330. 3; G. 532; H. 535. II.). — **exercitum hiemare**, &c., *they took it hard (moleste ferebant) that an army of the Roman people was wintering and getting a foothold (inveterascere, lit. grow old) in Gaul*. The infinitives, with their subj. accus. **exercitum**, are in indir. disc. after **moleste ferebant** (§ 333. b; G. 653; H. 523).

3. **mobilitate** [Et. 379]: § 245; G. 406; H. 416. — **novis imperiis** (dat. § 227. e; G. 345; H. 385) **studebant** = *were eager for a change of government (lit. new powers)*. Notice that **novis** is emphatic (see Appendix). — **ab nonnullis**, *by some also*: these were petty chiefs of clans.

**36. quod** (causal) . . . **occupabantur**, *because royal power was (constantly) usurped (by coups d'état on a small scale)*. Notice the indic.: Cæsar explains the statement of Labienus (**quod sollicitarentur**) by facts from his own knowledge (§ 321; G. 540; H. 516). A causal clause with the subjunc. (**occuparentur**) would indicate that the reason assigned formed part of the letter of Labienus. — **potentioribus**, *the more powerful* (§ 93. a). — **ad . . . facultates**, *the means to take men into their pay*. — **conducendos**, gerundive (§ 300; G. 433; H. 544). — **imperio nostro** (strictly a loc. abl., implying time, place, or condition: § 254; G. 393; H. 425), *under our dominion*. — **consequi**, complementary (§ 271 and n.; G. 424; H. 533. I. 2).

CHAP. 2. **nuntiis**, abl. of cause (§ 245; G. 406; H. 416). — **duas legiones . . . misit**: these were numbered XIII and XIV, making with the others eight in all, amounting (with auxiliaries) to perhaps 60,000 men. The proconsul seems to have had absolute authority to raise these levies. — **initā aestate** (abl. abs. expressing time when: § 255; G. 408; H. 431) = *in early spring*: **aestas** is the period from the spring equinox to that of autumn. — **qui deduceret**

(the antecedent is **Q. Pedium**), relative clause of purpose (§ 317; G. 545<sup>1</sup>; H. 445<sup>4</sup>). — **legatum**: see note on Bk. I. Chap. 10. § 3.

2. **cum primum**, &c.: *as soon as there began to be plenty of fodder* (i.e. when grass and young grain began to be abundant, so that the cavalry and baggage animals could move). — **inciperet**: § 325; G. 586; H. 521. II. 2. — **dat negotium**, *gives [it in] charge*. — **Senonibus**: these were north of the Ædui, on the upper course of the Seine; their name is preserved in *Sens*. — **reliquis Gallis**, *the rest of the Gauls* (§ 193; H. 440. N. 2). — **Belgis**, dat. with **finitimi** (§ 234. a; G. 356; H. 391. I.). — **uti . . . cognoscant**, *to find out*. This is a subst. clause of purpose in appos. with **negotium**: § 331. a; G. 546; H. 498. — **gerantur**, subj. as depending on **cognoscant** (§ 342; G. 631; H. 529. II.). (Observe that **ea** is the anteced. of **quae**, which is therefore not an interrog. but a rel. pron.; hence the clause is plainly not an indir. question.) — **seque . . . faciant**, *and inform him* (Cæsar) (§ 196. a; G. 521; H. 449<sup>1</sup>).

3. **constanter**, *consistently* (with one another): their accounts all agreed. — **manus** (acc. pl., subj. of **cogi**), *small bands* or companies. — **cogi**, *were gathering* (for the *voice*, see § III. N.<sup>1</sup>; G. 209; H. 465). — **exercitum conduci**, *a large force was being got together*.

4. **tum**: observe the emphatic position. — **non dubitandum** [esse] **quin**, *he must no longer hesitate*. The infin. of the Second Periphrastic Conjugation (§ 113. d. N; G. 243; H. 466. N.), here used in indir. disc. as obj. of **existimavit**. — **dubitandum** is impersonal (§ 146. d; G. 199. R.<sup>1</sup>; H. 195. II. 1). — **quin** can only follow a negative expression, as here **non existimavit**, etc. — **re comparata**; translate the abl. abs. freely, often by an active construction, *having got*, etc., or *when he had*, etc. — **quin . . . proficisceretur**, *to set out* (lit. *but that he should*, &c.): rel. clause of result, depending on **dubitandum** [esse] (§ 319. d; G. 551; H. 504). — **castra movet**, *breaks up camp*. — **diebus**, abl. of time *within which* (§ 256; G. 392; H. 429).

CHAP. 3. **eo**, *thither*. — **de improvise** (adverbial phrase), *unexpectedly*. — **omni opinione**, *than any one could think* (following the comparative **celerius**) (§ 247. b; G. 399. R.<sup>1</sup>; H. 417. I. N.<sup>5</sup>). — **Remi**: these occupied the territory near *Rheims*, in Champagne.

They were friendly to the Romans, who by their victory over Ariovistus (see Bk. I.) had made them the second power in Gaul: compare Bk. VI. Chap. 12. — **proximi Galliae**, *nearest to Gaul*: for the dat., see § 234. *a*; G. 356; H. 391. I. — **ex Belgis** (following **proximi**), *of the Belgae* (for partit. gen. **Belgarum**: § 216. *c*; G. 371. R.<sup>5</sup>; H. 397. 3. N.<sup>8</sup>) — **legatos**, *as ambassadors*. — **qui dicerent**: § 317; G. 545; H. 497. I.

2. The rest of the chapter consists of the speech of the ambassadors, as reported by Cæsar in indir. disc. See note on Bk. I. Chap. 3 (p. 11, above). Notice that the *principal clauses* are in the infin. with subj. acc., and all *dependent clauses* in the *subjunctive* (§ 336. ff.; G. 653; H. 522–524). In the dir. disc. this speech would read as follows:—

*Nos nostraque omnia in fidem atque in potestatem populi Romani permittimus, neque [nos] cum Belgis reliquis consensimus, neque contra populum Romanum conjuravimus, paratique sumus et obsides dare et imperata facere et oppidis recipere et frumento ceterisque rebus juvare; reliqui omnes Belgae in armis sunt, Germanique, qui trans Rhenum incolunt, sese cum his conjunxerunt, tantusque est eorum omnium furor, ut ne Suessiones quidem, fratres consanguineosque nostros, qui eodem jure et isdem legibus utantur, unum imperium unumque magistratum nobiscum habeant, deterere potuerimus quin cum his consentiant.*

**se in fidem permittere** = *put themselves under the protection* (“good faith”), &c. — **se suaque omnia**, *themselves and all their [possessions]* (“their all”): obj. of **permittere**. The subj. acc. is regularly expressed in the indir. disc.; but here it is omitted, to prevent the awkward repetition, — **se** (subj.) **se** (obj.). In the next clause **se** is expressed. — **permittere . . . consensisse . . . conjurasse . . . esse**, main clauses. — **neque**, *and [had] not* (§ 156. *a*; G. 482; H. 554. I. 2). — **cum Belgis**: § 248. *a*; G. 391; H. 419. I. — **paratos** (participial adj.), *ready*. — **dare, facere**, &c., infinit. following **paratos** (§ 273. *b*; G. 424; H. 533<sup>3</sup>). — **oppidis recipere**, *receive [the Romans] into their strongholds*: **oppidis** is abl. of place without **in** (§ 258. *f*; G. 387; H. 425. I. 1). The English idiom would lead us to expect **in oppida**, but see § 260. *a*; G. 384. R.<sup>1</sup>; H. 380. N. — **frumento**, abl. of means (§ 248; G. 403; H. 420). — **ceterisque rebus**, *everything else [necessary]* (lit. *the other things*: see Vocab.).

3. **qui . . . incolant**: in dir. disc. **incolunt**. — **tantum . . . ut**, correls. (see § 319. R.; G. 556; H. 500. II.). — **furorem**, *madness* (blind and unreasoning passion). — **ut . . . potuerint**, *that they* [the Remi] *could not dissuade*: result clause (§ 319; G. 554; H. 500. II.); for tense, see § 287. c. R.; G. 513; H. 495. VI. — **ne . . . quidem**: § 151. e; G. 444; H. 553.<sup>2</sup> — **Suessiones** (obj. of **deterre**): they occupied territory west of the Remi, about the modern *Soissons*. — **qui . . . utantur**, *although they enjoy the same rights and laws*; relative clause of concession (§ 320. e; G. 637; H. 515. III.). It would be subjunct. in dir. disc. also. — **unum imperium**, &c.: their close confederacy did not prevent the Suesiones from (**quin**) leaguering with the other party. — **cum ipsis**, *with themselves* (the Remi): in the indir. disc. **se** is regularly used to refer to the speaker but the oblique cases of **ipse** are occasionally used instead. Here **ipse** is used apparently for emphasis (§ 195. k; G. 298; H. 448). — **quin . . . consentirent**, *from leaguering with these* (the “conspirators”): rel. clause of result (§ 319. d; G. 551; H. 504) depending on **deterre**. Notice that **deterre** is negated by **ne . . . quidem**, above, which belongs to the whole clause, but is attached to the emphatic word.

CHAP. 4. **ab his**, *of* (from) *these* (the envoys) (§ 239. c. R.). — **quae . . . essent**, indir. question (§ 334; G. 462; H. 529). — **quid . . . possent**, *what strength they had in war*: **quid** is adv. acc. (§ 240. a; G. 331. R.<sup>3</sup>; H. 378. 2). — **sic**, *as follows*. — **reperiebat**, *found* (by repeated inquiry, as the tense shows). Observe that the rest of the chapter is in indir. disc., except the words **Remi dicebant** (in § 3).

2. **plerosque**, *most of* (§ 193; H. 440. N. 2): see the end of the chapter, and compare, regarding the Nervii, Tacitus, Germ. 28. The Belgians were, no doubt, chiefly of Celtic blood; but possibly they considered the German a more proud and heroic descent. — **ab Germanis**, abl. of source (§ 244. a; G. 395; H. 415. II. N.).

37. **Rhenum**: accus., governed by **trans** in **trāductos** (§ 239. b; G. 330; H. 376. N.). — **trāductos**, participle agreeing with **Belgas**. — **propter fertilitatem**: construe with **consedisse**. — **Gallos**: obj. of **expulisse**. — **incolerent**: for **incolebant** of the dir. disc. —

**solos . . . esse qui . . . prohibuerint**, *were the only ones who kept off*: rel. clause of characteristic, with **solos** (§ 320. *b*; G. 634; H. 503. II. I.). — **memoriā**, abl. of time (§ 256; G. 392; H. 429). — **ingredi**, *from entering* (§ 271. *a*; G. 532. R.<sup>1</sup>; H. 505<sup>4</sup>). — **qua ex re**, *in consequence of which (fact)*: abl. of cause (§ 245. N.; G. 406; H. 416. I.). — **fieri uti . . . sumerent** = *it was coming to be the case that they took upon themselves* (i.e. they were beginning, &c.): **uti sumerent** (result) is the subj. of **fieri** (§ 332. *a*; G. 558; H. 501. I.<sup>1</sup>). — **spiritus**, see Vocab. — **memoriā**, abl. of cause. — **sibi**: § 235; G. 343; H. 384. I. 2.

3. The rest of the chapter depends on **Remi dicebant**. — **se habere explorata**, *had found out all about (de)*, &c.: **habere explorata** differs but little in sense from **explorasse** (§ 292. *c*; G. 230; H. 388. I. N.); in construction **explorata** agrees with **omnia**, which is obj. of **habere**. (See note on **compertum habere**, Bk. I. Chap. 44.) — **propterea quod**, *because*. — **propinquitatibus**, *ties of blood*. — **adfinitatibus**, *alliances by marriage*. — **quantam quisque . . . pollicitus sit**, *how large a force each had promised*: indir. question, obj. of **cognoverint**. — **ad id bellum**, *for this war*. — **cognoverint**: the primary tense violates the *sequence of tenses*, to make the statement more vivid by putting it in the same tense that was used by the speakers (*Repraesentatio*). They said, **cognovimus**, *we know* (lit. *have found out*).

4. **Bellovacos**, near *Beauvais*. — **plurimum . . . valere**, *had most power*. — **et virtute**, &c., abl. of specification or abl. of cause. — **posse conficere . . . centum**, *could muster a hundred thousand men in arms*: **milia** is the noun with which the adj. **armata** agrees (§ 94. *e*; G. 308; H. 178). — **pollicitos [esse]**, *and had pledged*. — **ex eo numero**: § 216. *c*; G. 371. R.<sup>5</sup>; H. 397. 3. N.<sup>3</sup> — **electa** *choice troops*. — **sibi**, dat. of reference (§ 235; G. 343; H. 384. I. 2). — **suos**, *their own* (i.e. of the Remi): notice that the reflexive refers back to the speaker. See note on **cum ipsis**, Chap. 3, above.

5. **eos**, i.e. the Suessiones. — **fuisse . . . esse**: notice the difference of time; **fuisse** (in the dir. disc. **fuit**) refers to time *past*, **esse** (dir. **est**), to time *present*, with respect to the verb of saying (**dicebant**, line 8). — **totius Galliae**, partitive gen. (§ 216. *a*. 2; G. 370; H. 397. 3). — **regem**: showing that royal power had not yet been overthrown among the Belgians (see note to Bk. I. Chap.

2). — **cum . . . tum**, *not only . . . but also* (**partis** is obj. gen. after **imperium**: § 217; G. 361. 2; H. 396. III.). — **Britanniae**: first mention of Britain by a Roman author. — **obtinerit**, *had held*; in the dir., **obtinit**, *held* (subjunc. because subord. clause in indir. disc.). — **ad hunc . . . deferri**, *on him was conferred the chief command* (**summam**, subj. of **deferri**) *of the whole war*. — **propter**: § 245. *b*; G. 407. R.<sup>1</sup>; H. 416. I. 2. — **voluntate**, abl. of manner (modified by **omnium**) (§ 248. R.; G. 401; H. 419. III.).

6. **habere**: the subj. must be supplied from **Suessiones**, above. — **numero**, abl. of specification (§ 253; G. 398; H. 424). — **Nervios**, &c. (see Map): the names of several of these tribes are found in the modern towns *Arras, Amiens, Calais, Vermandois, Condroz*; the name **Germani** seems to belong especially to the four last-named (*Condrusi, Eburones, &c.*). — **feri**: pred. after **habeantur**, *are regarded*. — **qui . . . appellantur**: the indic. shows that this is an explanatory note added by Cæsar, and not a part of the ind. disc.; **qui . . . habeantur** above, however, is a remark made by the Remi, as is shown by the subjunc. — **Condrusos**, &c.: obj. of **arbitrari**. — **arbitrari** (deponent), infin. of ind. disc., with subj. **se** understood, referring to the Remi, *that they estimated*. — **ad**, *at about*.

CHAP. 5. **cohortatus, prosecutus** (for the tense of these participles, cf. § 290. *b*; G. 278. R.; H. 550. N.<sup>1</sup>) = *addressing them cheerily, and making liberal promises*. — **convenire . . . adduci**: infin. with subj. acc., regularly used as obj. of **jussit** (§§ 330. 2, 331. *a*; G. 546. R. I; H. 535. II.). — **obsides** (pred. appos.), *as hostages*: if the chiefs should break their faith, these boys would probably be sold as slaves. — **ad diem**, *by the [appointed] day*.

**38.** 2. **quanto opere** (often written **quantopere**) . . . **intersit** [Et. 459], *how greatly it concerns both the republic (Rome) and their common safety*. (For the genitives, see § 222; G. 381; H. 406. III.) — **intersit**: indir. question (§ 334; G. 462; H. 529. I.). — **manūs** (acc. pl.) . . . **distineri**: infin. clause, subj. of **intersit**. — **ne conflagendum sit**, *lest they should have to contend*: final clause (§ 317; G. 545. 3; H. 497. II.), depending on **distineri**. (For the use of **conflagendum sit**, see §§ 146. *c*, 129; G. 199. R. I, 243. R. 2; H. 301. 2, 234):

3. **Id . . . coeperint**: indir. disc., depending on **docet**. — **id** refers to **manus distineri**, above. — **fieri . . . populari**, complem. inf. (§ 271; G. 424; H. 533). — **Bellovacorum**: these lay farthest west and most remote from Cæsar's field of operations; so that the manœuvre indicated would divide the enemy (cf. Chap. 10<sup>4</sup>). — **introduxerint . . . coeperint**: fut. condition; in the dir. disc. these would be fut. perf. (§ 307. c; G. 598; H. 508). — **suas** (reflexive) refers to **Haedui**; **eorum** (demonstr.), to **Bellovacorum**.

4. **Postquam . . . vidit** (§ 324; G. 563; H. 518), *as soon as he saw*. — **copias**: subj. of **venire**. — **coactas**: part. with **copias**. — **ad se venire**, *were coming straight toward him* (indir. disc.). — **neque**: **que** connects **vidit** and **cognovit**; **ne-** with **jam** = *no longer*. — **abesse**: depending on **cognovit**. — **ab iis**: construed with **cognovit**. — **flumen . . . exercitum . . . traducere**, *to lead his army across the river*: **exercitum** is dir. obj. of **traducere**; **flumen** is secondary obj., depending on **trans** (**trā-duco** = **trans-duco**) (§ 239. b; G. 330. R. 1; H. 376). — **Axonam** (apposition), *the Aisne*: here flowing nearly due west, and joining the Seine below Paris, through the Oise. — **quod**: § 198; G. 616; H. 445. — **in extremis finibus**, *in the remotest part of the territory of the Remi* (§ 193; H. 440. 2, notes 1 and 2): the phrase is used in a general sense merely; for Bibrax, a town of the Remi, lay eight miles beyond. — **castra**: traces of Cæsar's works at this place were discovered in 1862, on a low hill called *Mauchamp* (see Plan IV.).

5. **quae res**, *which movement* (or *manœuvre*), i.e. his having crossed the river, and then pitched his camp where he did. Cæsar's camp was protected in the rear by the Axona, and in front by a small marshy stream. — **ripis**, abl. of means (§ 248; G. 403; H. 420). — **post eum quae essent** (§ 320; G. 633; H. 503. 1), *the rear of his army* (those things which were behind him). — **tuta**, pred. acc. (§ 239. a; G. 334; H. 373. I. N. 2): the dir. obj. is **ea**, the omitted antecedent of **quae**. — **ut . . . posset**: subst. clause of result, obj. of **efficiebat** (§ 332; G. 557; H. 501. II. 1). — **commeatus**, subj. of **posset**. — **efficiebat**: the subj. is still **quae res**; observe the imperfect tenses.

6. **in altera parte**, *on the other side* (i.e. on the left bank of the Aisne, towards the Remi): Cæsar had crossed the stream, and encamped on the side next the Suessiones. — **in altitudinem**, con-



nected with the measure following. — **pedum XII.**, gen. of measure, with **vallo** (§ 215. *b*; G. 364. R.; H. 396. V.). — **vallo fossaque**, abl. of means. — **duodeviginti pedum**, of 18 feet (in width), i.e. the moat: see note on Bk. I. Chap. 49, "The Camp." — **munire**: see note on **convenire**, second line of this chapter.

ARRANGEMENT OF THE COHORTS IN CAMP. — We interpret from Hyginus the following arrangement of a cohort of six centuries.

The cohort encamped in a space of 120 ft. front and 180 ft. depth. This was divided, on lines parallel to the front, into 6 portions of 120 ft. by 30 ft. Each portion was for one century. From the length of the front, 12 ft. are to be deducted for the street dividing the cohort from the adjacent one. That leaves 108 ft. for the tents. Each century had 8 tents: 6 for the soldiers, one for the centurion, and one for the servants. As each tent was 10 ft. square, the length actually covered by tents would be 80 ft. This leaves 28 feet for the 7 intervals between the tents, or 4 feet for each interval. The three first centuries of the three maniples had their tents facing the wall, and the three second had theirs facing from the wall. Thus the two centuries of one maniple would be stationed back to back. The second of one maniple would face the first of the next, divided from it by a street 12 ft. wide, parallel to the wall.

From the 30 ft. depth of the space allotted to the century, 6 ft. must be allowed for their half of the street, 10 ft. for the tents, 5 ft. behind the latter for stacking the weapons, and, finally, 9 ft. for the pack animals.

The several cohorts of a legion, according to the room, could be placed side by side in a line, or in several lines.

CAMP DUTIES. — When the van reached the camping-ground selected, it was immediately formed with front towards the enemy to cover the work of fortifying. Strong details of cavalry reconnoitred in all directions, while the engineers immediately set to work at measuring and staking out the camp. As the legions arrived, they proceeded each to its allotted place, and laid aside baggage and arms (excepting swords) in the space behind the site for the tents (*arma in contubernio deposita*). The cohorts assigned to guard duty of course retained their arms, and proceeded at once to their posts. Baggage and arms being laid aside, the legions marched to the street next the wall and were there told off, some for work within the camp, some for fortifying. The latter work, having already been measured (*opere dimenso*\*) was begun at once (*castra ponuntur, muniuntur* †). When the baggage train arrived, the animals were tethered, each in its proper place,

\* Bk. II. 19. † Bk. I. 49. II. 5, 13.

and were then unloaded by the servants (*calones*). The tents, as a rule, were only pitched when the fortifications were completed. When not near the enemy, however, and especially in stormy weather, the tents would be pitched (*tabernacula constituere, statuere*) immediately on arrival. As soon as the fortifications were finished, the bulk of the cavalry was withdrawn into the camp. A few squadrons were left on picket without (*equites in statione\**), and these sent scouts (*exploratores†*) in all directions. Any special duty of gaining information was performed by spies (*speculatores‡*).

At each gate was usually placed a cohort on guard, the four coming each from a different legion (*cohors in statione ad portam§*). In the daytime few sentries were posted. But during the night doubtless each cohort of the guard lined the redan before the gate, and its side of the wall, thickly with sentinels. Of course, in special cases the guard was strengthened. Besides the guards at the gates, one cohort at least was detailed for duty in the camp, and was stationed in the *praetorium* and *quaestorium*.

As soon as the fortification was completed, the supper was prepared and eaten. For this meal the staff assembled in the *praetorium*, and remained there until nightfall. During this time the general could conveniently issue his orders for the night and for the next day. At nightfall, also, the musicians of the army assembled to sound the tattoo. This was the signal for setting the night watch. The cavalry pickets were drawn into the camp, except a very few single horsemen as outlying sentries (*speculatores*). The guard cohorts were probably changed at the tattoo, the new guard going on duty now to serve 24 hours. The night sentries (*vigiles*) were at once posted on the *tambours* (*titula*) and wall. The night from sunset to sunrise was divided into four equal watches (*vigiliae*). Each cohort on guard was divided accordingly into four reliefs, one of which should be on duty during each watch. The other three reliefs could rest. Of course, they lay on their arms, ready for duty at a moment's notice. If the cohort contained only about 300 men, it will readily be seen that 70 men could compose one relief. This number, for a length of wall of 2100 ft. (one side of the camp), would give one sentinel for each 30 ft. The different reliefs were signalled by the trumpeters (*buccinatores*).

At daybreak the musicians sounded the *reveillé*. If the march was not to be resumed, the guard cohorts drew in their night sentries, and posted the less numerous sentinels for the day. The cavalry pickets took their

\* Bk. V. 50. † Bk. II. 11. III. 2. VII. 44. ‡ Bk. II. 11. V. 49.  
§ Bk. IV. 11. VI. 37.

posts (*stationes*), and sent out their scouts (*exploratores*). At noon this cavalry guard was relieved.

During the night the rounds of the sentries were probably made by the centurions of the guard. Occasionally, also, the tribunes on duty, and the general himself, would inspect the guards, to make sure of the vigilance with which the camp was watched.

If camp should be made in the presence of an enemy in force, the usual vanguard would not be enough to cover the operation. One or two legions would then be deployed in triple line of battle. The first two lines would keep off the enemy, and the third would do the work of fortifying.\*

The army might leave the camp either to attack a near enemy, or to continue the march.

In the first case the tents were left standing, the baggage remained in its place, and a guard was left in charge. This guard might consist of a detail from each legion, or of entire legions. The latter would be likely to occur when legions of raw recruits were present. These would naturally be left within the walls.†

In case of continuing the march, the camp was abandoned. At the first signal of the bugles (*signum profectionis*), the tents were struck; at the second (*vasa conclamantur*), they and the rest of the baggage were packed on the beasts; at the third the march began. To conceal the departure from the enemy, the signals might be omitted. Still it was deemed a point of military honor to sound them.

CHAP. 6. **nomine**, abl. of specification (§ 253; G. 398; H. 424). — **milia passuum octo**, *eight miles* (8000 [of] paces): acc. of extent of space (§ 257; G. 335; H. 379). For **milia**, see § 94. *e*; G. 308; H. 178. — **passuum** is partit. gen. (§ 216; G. 366; H. 397). — **ex itinere**, *on the march* (lit. *from the march*, i.e. turning aside from their course to attack the town). — **magno impetu**, abl. of manner (§ 248. and R.; G. 401; H. 419. III.). — **aegre sustentatum est** (impersonal), *it was with difficulty* [that they] *held out*. — **eo die**, abl. of time: § 256; G. 392; H. 429.

2. **Gallorum . . . haec**, *the attack* (mode of attacking) *of the Gauls, being the same as* (**atque**) *that of the Belgians, is THIS* (the following). — **haec**, pred. — **ubi**: § 324; G. 563; H. 518. — **circumjecta multitudine** (abl. absolute) . . . **moenibus** (dat., § 228; G. 346; H. 386. 2), *a host of men being thrown round the walls*.

\* Bk. I. 49.

† Bk. II. 8. III. 26. V. 9. VI. 37.

— **jaci**, complem. inf. — **coepti sunt**: see § 143. *a*; G. 424. R. 1; H. 297. I. 1. — **defensoribus**, abl. of separation (§ 243. *a*; G. 389; H. 414. I.). — **testudine facta**, *making a testudo*: see note, Bk. I. Chap. 24.

3. **Quod**, *which* (i.e. the movements just described). — **tum**, *in this instance*. — **multitudo**, subj. of **conicerent** (plu. verb, § 205. *c*; G. 202. Exc. 1; H. 461. 1). — **cum . . . conicerent**: **cum** causal (§ 326; G. 587; H. 517). — **consistendi**: gen. of gerund, with **potestas** (§ 298; G. 429; H. 542. I.). — **nulli** (dat. of possession, § 231; G. 349; H. 387), *nobody could keep a foothold on the wall* (lit. *power of standing on the wall was to nobody*).

4. **cum** (temporal, see § 325; G. 582; H. 521) . . . **fecisset**, *when night had put an end to* (made an end of) *the attack* (gerund, obj. gen., § 217; G. 361; H. 396. III.). — **summa nobilitate et gratiâ**, [a man] *of the highest*, &c. (abl. of quality, § 251; G. 402; H. 419. II.). — **inter suos**, *among his* [fellow-citizens]. — **oppido**: dat., with **praefuerat** (§ 228; G. 346; H. 386). — **unus ex iis**, *one of those* (§ 216. *c*; G. 371. R.<sup>5</sup>; H. 397. N. 3). — **legati**, *as ambassadors*. — **nisi . . . posse**: indir. disc. depending on the idea of *reporting* contained in **nuntium mittit**. The subj. is **sese**; the main verb, **posse**. — **sibi**: the dat. is used with **subsidium submittatur** (§ 227; G. 345; H. 381. I.) instead of **ad se**, because the idea of *helping* is more prominent than that of *motion*. — **submittatur**: subjunc., because subord. clause in indir. disc.; in the dir. disc. this would be fut. ind. (§ 307. *a*; G. 597; H. 508. 2). — **sustinere**, *hold out*. (In the dir. disc. the message of Iccius was: **nisi subsidium mihi submittetur, me diutius sustinere non potero**.)

CHAP. 7. **eo**, *thither, to that place*. — **isdem ducibus usus**, *employing the same men* [as] *guides*: for the abl., see § 249; G. 405; H. 421. I. Observe that **ducibus** is a *second* obj. after **usus**.

39. **nuntii**, *as messengers*. — **Numidas et Cretas**, *Numidians* (from Algiers) *and Cretans*: both nations (especially the Cretans) were famous bowmen. — **sagittarios**, apposition. — **Baleares** (adj.): the inhabitants of the Balearic Islands, east of Spain, were famous slingers. — **subsidio oppidanis** (§ 233; G. 350; H. 390), *as aid* (reinforcements) *to the townspeople*: dat. of service with dat. of

person affected. — **et . . . et, both . . . and.** — **studium . . . accessit, eagerness for making sallies was roused in the Remi** (lit. *was added to the Remi*, dat.). — **hostibus, from the enemy** (dat., § 229; G. 344. R.<sup>2</sup>; H. 385. 2). — **potiundi oppidi:** § 296. R.; G. 428. R.<sup>3</sup>; H. 421. N.<sup>4</sup>

2. **morati . . . depopulati . . . vicis incensis:** observe the change of construction. The Latin can use a perf. part. with active meaning only (as here) of *deponent verbs*. The corresponding construction with other verbs is the abl. absolute with the perf. part. pass.; as here, **vicis** [Et. 85] **incensis**, which is to be translated *having set fire to the villages*. — **quos** takes the gender of **vicis** (collected habitations), as more important than **aedificiis** (scattered buildings); this agreement is analagous to that of pred. adjs. (§ 187. b; G. 616. R. 5, 282; H. 445. 3. N.<sup>1</sup>, 439. 2). — **omnibus copiis** (abl. of accompaniment), *with all their troops*: for the omission of **cum**, see § 248. a; G. 391. R.<sup>1</sup>; H. 419. I. — **ab milibus passuum minus duobus, less than two miles off:** **ab** is used adverbially (§ 261. d; G. 416. R.; H. 379. 2. N.). — **milibus** is abl. of degree of difference (§ 250; G. 400; H. 423); **minus** does not affect the construction (§ 247. c; G. 311. R.<sup>4</sup>; H. 417. I. N.<sup>2</sup>). — **amplius** is acc. of extent of space (§ 257; G. 335; H. 379), and **milibus** abl. after the compar. (§ 247; G. 399; H. 417).

CHAP. 8. **eximiam opinionem virtutis, their high reputation for valor** (obj. gen., § 217; G. 361. 2; H. 396. III.). — **proelio supersedere, to defer the engagement:** for the abl., see § 243. a; G. 388; H. 414. **supersedere** is used as the complement of **statuit** (§ 271. a; G. 424; H. 533. I. 1). — **quid . . . posset . . . quid auderent, indir. questions.** — **virtute, what the enemy amounted to in point of valor.** — **periclitabatur, experimented** (cf. **periculum**, the original meaning of which is *trial*, then *risk*).

2. **esse, indir. disc.** — **loco . . . idoneo, the ground being by nature proper and well adapted for, &c.** (abl. absolute); or (locative abl.) *in a place, &c.* (§§ 254, 258. f; G. 387; H. 425. 2). — **ad . . . instruendum:** § 300; G. 433; H. 544. I. — **editus, elevated, rising.** — **tantum, &c., spread over as much (tantum) ground as (quantum) a line, &c.** — **loci, partitive gen. with quantum, but more conveniently translated with the correl. tantum.** — **adversus, right**

*in front*. — *in latitudinem, in breadth* (i.e. from the camp towards the confluence of the *Miette* with the *Aisne*). — *ex utraque parte, on both sides*. — *lateris dejectūs* (acc. pl.), *lateral slopes* (lit. *slopes of the sides*). — *in frontem, &c.*, *falling with an easy slope in front* (i.e. to the west), *sank down gently to the plain* (see Plan IV.).

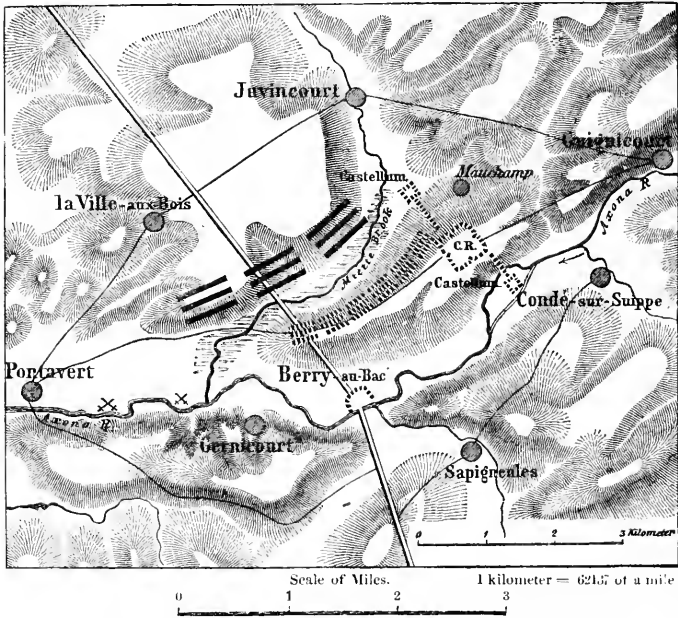

Plan IV. *Battle on the Aisne (Arona)*. Bk. II. Chap. 5-10.  
c. r. Castra Romana.

3. *transversam . . . obduxit, dug a ditch at right angles* to his line of battle. — *passuum quadringentorum*, gen. of measure (§ 215. *b*; G. 364. R.; H. 395. V.). — *ad extremas fossas, at the ends of the ditches* (§ 193; H. 440. N.<sup>2</sup>). — *ne . . . possent, that the enemy might not be able* (purpose). — *instruxisset, subj. by attraction* (§ 342; G. 665. at end; H. 529. II.) for fut. perf. ind. with *cum* (§ 325. *c*; G. 582; H. 521. I.). — *quod tantum multitudine poterant, because they were so strong in numbers* (abl. of specification):

this clause is parenthetical, and hence is not (like *instruxisset*) attracted into the subjunc. — *ab lateribus*, *on the flanks* (§ 260. *b*; H. 434. I.): modifying *circumvenire*. — *pugnantes*, acc. pl. — *suos*, *his* (Cæsar's) *men*.

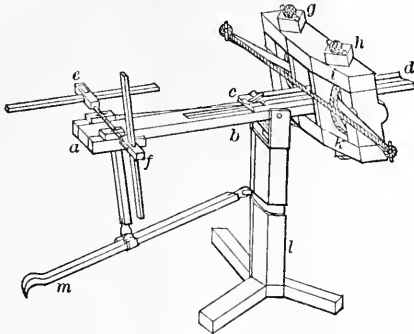

Fig. 17. *Catapulta*.

TORMENTA. — The artillery of the Romans consisted of various machines for hurling huge arrows, stones and the like. They were of three kinds, — *catapultæ*, *ballistæ* and *scorpiones*. Their probable construction may be

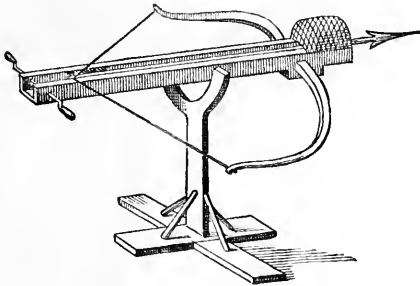
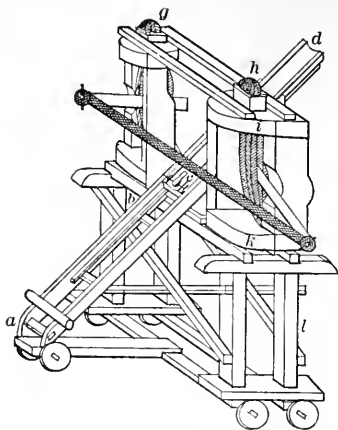

Fig. 18. *Scorpio*.

seen in the annexed cuts. Usually the catapults shot arrows, and the *ballistæ* great stones. The scorpions were really light catapults, and so were sometimes used as a sort of field artillery. The others were generally employed only in the attack or defence of fortified positions, be-

Fig. 19. *Ballista.*

ing too clumsy to be of service in the field. These machines were repaired and kept in order by the *fabri*, a body of whom were always attached to the army. It may here be remarked that the *fabri* also cared for the weapons and armor, and constructed bridges as well. It is obvious that after each successful battle the *pila* could easily be gathered and repaired.

The word *tormenta* (from *torqueo*, *twist*) refers to the principle on which it will be seen from the cuts that all these machines must have been constructed.

4. *si . . . esset*, if there should be need of anything. — *quo*: § 243. *e*; G. 390; H. 414. IV. — *esset*: protasis of a fut. condition (*si . . . erit*); here in the subjunct., because depending on the final clause *ut . . . possent* (§ 342; G. 666; H. 529. II.). — *subsidio*, dat. of purpose or end (§ 233; G. 350; H. 390. N.<sup>2</sup>). — *suas*: notice the emphatic position (see Appendix), *THEIR forces too*. — *copias . . . eductas instruxerant* (the Latin is fond of using a participle instead of an additional finite verb), *had led out and drawn up their troops* (lit. *had drawn up their troops* [having been] *led out*).

CHAP. 9. *palus*, a wet meadow (before mentioned), traversed by a little stream, the *Miette* (Plan IV.). — *non magna*, of no great size. — *nostrum*, possess. pron. (possess. gen. would be impossible, § 197. *a*; G. 360. R.<sup>1</sup>); *hostium*, possess. gen. (§ 214; G. 360; H. 396. I.). Notice that the two constructions are the same in sense, and connected by a co-ordinate conjunction, *et*. — *si . . . transirent*, if our men would cross: indir. question (§ 334. *f*; G. 462; H. 592. I. N.<sup>1</sup>). — *expectabant*, were waiting [to see]. — *adgrederentur*: purpose, depending on *parati*, &c. — *si . . . fieret*, in case they should begin the passage (lit. a beginning of crossing should be made by them): fut. condition



(*si . . . fiet*); here in the subjunc., because part of the final clause (§ 342; G. 666; H. 529. II.)

**40.** 2. *proelio equestri, a cavalry skirmish.* — *contendebatur*, impersonal (§ 146. *c*; G. 199. R. 1; H. 195. II. 1). — *neutri* (pl), *neither party.* — *secundiore . . . nostris*, *the cavalry skirmish [proving] more favorable to our men:* abl. absolute (for dat. *nostris*, see § 234. *a*; G. 356; H. 391. I.). — *esse*: § 330. *a* (cf. *b* and *c*); G. 528; H. 534. 1. — *post*, *behind.*

3. *traducere*: for the inf., see § 271. *a*; G. 424; H. 498. II. N.<sup>1</sup> — *eo consilio, ut*, *with this design, that, &c.:* the final clauses with *ut* are in apposition with *consilio* (§ 317. *a*; G. 545. 1; H. 499. 3). — *castellum*, *the redoubt* (“*tête de pont*”) beyond the river, held by Sabinus (Chap. 5<sup>6</sup>). — *si possent, si minus potuissent*, fut. conditions (*possent* represents the fut., *potuissent* the fut. perf., indic. They are subjunc., because each depends on a subjunc.). — *minus, not.* — *popularentur, prohiberent*: in same construction as *expugnarent.* — *magno nobis usui*, dat. of purpose or end with dat. of person (§ 233; G. 350; H. 390. I.). — *ad bellum gerendum* (gerundive, depending on *usui*), *for carrying on the war* (§ 300; G. 433; H. 554. 1). — *commeatu*: § 243 *a*; G. 389; H. 414. I.

CHAP. 10. *Cæsar*: words thus italicized are omitted or obliterated in the Ms. — *certior factus, being informed.* — *ab Titurio*, abl. of voluntary agent. — *levis armaturæ* (gen. of description), *of light equipment = light-armed* (see p. 23, Fig. 5). — *Numidas, &c.:* these light-armed troops were trained runners, and so “got round by the bridge to the ford in time to stop the passage of the Belgians.” — *traducit*: with two accs. (see note on *flumen*, Chap. 5<sup>4</sup>).

2. *pugnatum est*, cf. *contendebatur* (above, Chap. 9<sup>2</sup>). — *adgressi, having attacked* (at the stream below, probably, west of Cæsar’s camp). — *conantes*, with *reliqu s.* — *circumventos interfecerunt, surrounded and killed* (cf. note on *eductas*, Chap. 8<sup>2</sup>).

3. *ubi . . . intellexerunt*: § 324; G. 563; H. 518. — *de expugnando oppido, with sword to taking the town by storm* (§ 301; G. 432; H. 544. 2). — *neque nostros, &c. (progredi with its subj. acc. nostros is obj. of viderunt; ne-que = and not), and saw that our men did not advance to worse ground for the sake of fighting.* — *pugnandi* (gerund) *causâ* (§§ 245. *c*, 318; G. 372; H. 542. I., p. 221,

foot-n. 2): purpose. — **constituerunt** here has two objects: (1) **optimum esse**, &c. (indir. disc.), (2) [ut] **convenirent** (subst. clause of purpose, § 331. f. R.; G. 546. R.<sup>3</sup>; H. 499. 2). The subj. of **esse** is the infin. clause **quemque reverti** (§ 330; H. 539. i.), *they decided that the best thing was for each man to return to his own home*. Thus the confederacy dissolves into a mere defensive alliance, and the Nervii, &c., are cut to pieces in detail. — **domum**: § 258; G. 410; H. 380. 2. 1. — **quorum**: the antecedent is **eos**. — **introduxissent** (§ 342; G. 666; H. 529. II.) stands for the fut. perf. — **convenirent** (sc. **ut**: § 331. f. R.; G. 546. R.<sup>3</sup>; H. 499. 2): one of the objs. of **constituerunt**. — **decertarent . . . uterentur**: purpose, depending on **reverti** and **convenirent**.

4. **haec quoque ratio**, *this further consideration*. — **quod . . . cognoverant**: indic., because Cæsar gives the reason on his own authority (§ 321; G. 539; H. 516. I.). The clause is in appos. with **haec ratio**. — **Divitiacum . . . adpropinquare**: see Chap. 5<sup>3</sup>. — **finibus**: dat. after **adpropinquare** (**ad fines** might have been used). — **persuaderi**: impersonal (§ 230; G. 199. R.<sup>1</sup>; H. 301) complem. infin. with **poterat**. — **ut**, &c.: subst. clause, subj. of **poterat**. — **neque . . . ferrent** = *and so fail to carry* (lit. *and not carry*) *relief to their own people*. — **suis**: § 227; G. 345; H. 385. I.

41. CHAP. 11. **magno . . . tumultu**, abl. of manner. — **nullo certo ordine**, *in no regular order of march*. “Imagine a *débauche* of 236,000 men, besides camp-followers, women, &c.” — **cum**: causal. — **primum itineris locum**, *the first place on the march*. — **pervenire**: § 271; G. 424; H. 533. — **fecerunt**, notice the emphatic position (see Appendix): cf. the Eng. “the *result* was.” — **ut . . . videretur**: subst. clause of result, obj. of **fecerunt** (§ 332; G. 557; H. 498. II. N.<sup>2</sup>). — **fugae**: § 234. a; G. 356; H. 391. I.

2. **re . . . cognita**, abl. absolute. — **speculatores**, *spies*: they obtained information by mingling in disguise with the enemy; while the *scouts* (**exploratores**) were squads of cavalry who ranged the country in the vicinity of the army. — **veritus**, *fearing* (§ 290. b; G. 278. R.; H. 550. N. 1). — **quod . . . nondum perspexerat**, *because he had not yet seen clearly*. — **qua de causa discederent**: indir. question, obj. of **perspexerat** (§ 334; G. 462; H. 529. I.). — **castris**, *in camp* (§ 258. f; G. 387; H. 425. I. 1).

3. **ab exploratoribus**, *by scouts*: abl. of agent. Cf. above **per speculatores**, *through (by means of) spies* (§ 246. *b*; G. 403; H. 415. I. N. 1). — **omnem equitatum**: see note on Chap. 17, "The March," III. 2. — **qui moraretur**, rel. clause of purpose. — **novissimum agmen**, *the rear*. — **his**, dat. with **praefecit**. — **T. Labienum subsequi**: obj. of **jussit** (§ 330. 2; G. 536. R.<sup>1</sup>; H. 535. II.).

4. **novissimos**, *those in the rear*. — **cum**: causal. — **ab extremo agmine**, *in the rear*. — **quos** relates to the implied subj. of **consisterent**. — **ventum erat**, impersonal (§ 146. *d*; G. 199. R.<sup>1</sup>; H. 301. I). — **priores** (supply **et**), *and those in advance*. — **quod . . . viderentur**, *because they seemed* (i.e. *they thought themselves*). **viderentur** is subjunc., as being part of the subjunc. clause **cum . . . ponerent**. — **exaudito clamore, perturbatis ordinibus** (abls. absolute, the first defining the time of the second), *breaking ranks on hearing the outcry* (of those engaged in the rear). — **omnes ponerent**, *all sought safety in flight* (lit. *placed safety for themselves* (**sibi**, § 235; G. 344; H. 384. 4) *in flight*): **ponerent**, same construction as **consisterent** and **sustinerent**.

5. **tantam . . . spatium**, *killed as great a number of them as the time* (before night) *allowed* ("as the day was long"): notice the correls. **tantam . . . quantum** (§ 106; G. 645. 1; H. 191). — **sub occasum solis**, *toward sunset* (cf. **sub vesperum**, Chap. 33<sup>1</sup>).

CHAP. 12. **postridie ejus diei**, *next day* (lit. *on the day after that day*): for the gen., see § 214. *g*; H. 398. 5. — **priusquam . . . recipient**, *before the enemy could recover themselves* (§ 327; G. 579; H. 520). — **Remis**: § 234. *a*; G. 356; H. 391. I. — **magno itinere**, *by a forced march*. — **Noviodunum** (now *Soissons*) about 20 miles west of Bibrax. *Soissons* is derived from *Suessiones*.

2. **ex itinere**, i.e. by filling up the ditch and scaling the walls, without waiting to throw up works or form regular lines of approach. — **paucis defendentibus** (abl. absolute, denoting concession), *though there were few defenders*. — **oppugnare** means, *to attack*; **expugnare**, *to take* (by storm). Unable to take the town by storm, Cæsar was obliged to begin a regular siege.

THE SIEGE. — This is the first mention in Cæsar of an attack on a walled town. We give for reference a full description of siege operations.

1. The principal work of a regular siege was the mound (*agger*). This

was always begun at a distance from the wall very nearly out of the reach of missiles. It was then gradually extended in the direction of the point to be attacked, and was at the same time gradually increased in height until on a level with the top of the walls, or even higher. When this mound was completed, the storming party moved on its top to the attack.

2. The height was often considerable. Before *Avaricum*\* it was 80 ft., and as much before *Massilia*. The length, of course, depended on the power of the enemy's missile weapons. It seems probable that those built in assaulting the Gallic towns were not very long. The least distance from the hostile wall at which the construction could have been begun was from 400 to 500 ft. The width above must have been enough for a storming column, very likely of the usual formation. If we take this to be the front of a maniple, the least breadth would have been 50 ft. The sides might be quite steep, as we shall see later. A fabric 80 ft. high and 50 ft. wide on top, might have been 60 ft. wide on the ground. To the building of the *agger*, it must be remembered, everything else in the siege was subordinated.

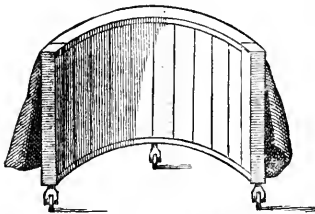

Fig. 20. *Pluteus*.

3. By way of preparation for its construction, first of all the ground must be levelled for the foundation. This could be done by workmen protected by *testudines*, stout movable sheds (*a*, Fig. 26). Then the workmen, both those building the *agger* and those providing the material,

must be guarded from the missiles of the enemy. The former were protected by *plutei*, large standing shields, which could be advanced from time to time. The others brought the material in covered galleries, composed of a series of *vineae* (sheds like the *testudines* in Fig. 26, but entirely open at each end), reaching to the point of beginning the *agger*. The workmen were also protected by archers, slingers, and *tormenta*, drawn up in a line parallel to the hostile wall. The archers and slingers were themselves protected by a line of *plutei*; the *tormenta* were placed usually in moving towers (*c*, Fig. 26). The towers were increased in height as they moved forward by putting up additional stories. Each floor often had an outside gallery protected by a sort of palisade. These parallels (i.e. the *plutei* and towers) must also have had covered approaches of long lines of

\* Bk. VII. 24.

*vineae* (r o, Fig. 25). Under shelter of these *vineae*, too, were posted bodies of legionaries (*cohortes expeditae*\*) to cover the operations and resist sorties. Farther in the rear, outside the camp, bivouacked strong bodies of troops, as additional supports.

4. The strength of the various protections would of course depend on the power of the enemy's missiles. Usually the rude walls of the *vineae* were only of a sort of wattled work.

5. Sometimes towers (*turres ambulatoariae*) were placed on the *agger* (Bk. VII. Chap. 17). In such cases the top of the latter was designed to be a smooth roadway; and its height had merely to be enough for the tower to have sufficient elevation. This was probably a quicker way of approach, as it saved building a considerable part of the *agger*; but it was not so convenient for a column of attack. The column would have to

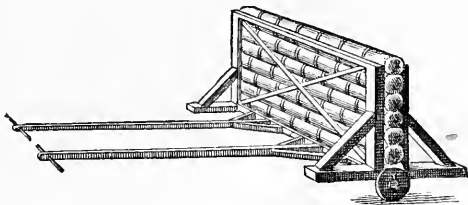

Fig. 21. *Pluteus*.

pass over a drawbridge let fall from the tower upon the enemy's wall. As a rule, the tower accompanied the construction of the *agger* at its side (*tt*, Fig. 25), and served as a battery to clear the enemy from the wall, and as a redoubt in the line of approaches.

#### CONSTRUCTION OF THE AGGER.

6. Fig. 24 gives a longitudinal vertical section of the *agger*. *ab* is the city wall to be attacked. The section of the *agger* when complete is represented by *abcfehn a*. Of this only a little part, as *cefn d*, can be built regularly. The portion next to the wall, *abcd*, must then be filled pell mell at the last moment.

7. To begin the regular structure, a line of *vineae* (*gl*, Fig. 25) was first advanced from the depot of material to the point of beginning. About 30 ft. in advance of this point, and at right angles to the line of huts, was placed a line of *plutei*, to protect the workmen. Through the gallery formed by the huts the workmen now carried the material. This was, first

\* Bk. VII. Chap. 27.

of all, logs 20 to 30 ft. long and from a foot to a foot and a half thick. These were piled in layers alternating in direction, "cob house" fashion (Fig. 23). In the middle was left a passage some 10 or 12 ft. wide. The interstices were filled with stones, sods, brush, &c. When the work had reached a height of about 7 ft., a layer of timbers was placed entirely across it, thus at the same time covering over the passage and making a floor for a second story. Thus the first story was completed to a length of 30 ft. The *plutei* were now moved 30 ft. ahead, and, in like manner as before, a second section of the *agger* was built. The covered passage through the first section served the same purpose as the line of *vineæ*, for the protection of those carrying the material. At the point of beginning, steps were made so as to reach the top of the first story.

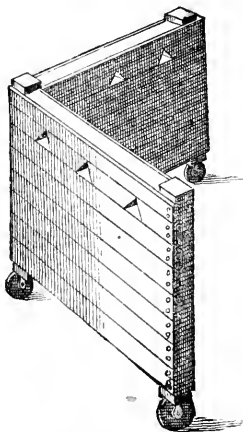

Fig. 22. *Pluteus*.

8. When the work had been advanced in this way some 100 ft., a second line of *plutei* (*k*, Fig. 24) was placed on top of the first story and across it; and under their protection a second story was begun, just like the first. At the beginning of this, room was left for a platform (*fg*) by which to approach the covered gallery (*n*) of the second story. In this manner the work was steadily advanced, until the entire structure had reached the required height. Each additional story had its covered gallery running throughout its length, its steps, and platform.

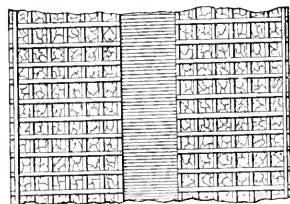

Fig. 23. *Portion of Agger*.

9. When the regular structure had been brought as near the hostile wall as is safe, then through the various galleries a great mass of material, stones, fascines, sods, &c., was carried, and thrown out into the remaining space, until it is quite filled. The sides of the regular structure were protected from fire by being covered with fresh hides. When the *agger* was brought quite to the wall, the time for assault had arrived. Archers, slingers and *tormenta* swept the wall with missiles, while the column of attack mounted

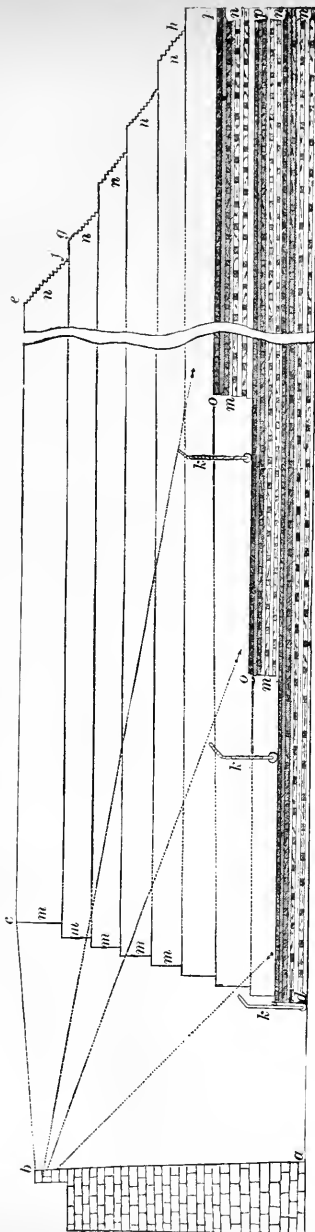

Fig. 24. Vertical Section of Agger and Hostile Wall.

*a b c e f h u a.* Entire section to be filled up. *c e f h u d.* Portion regularly constructed. *a b c d.* Portion filled at the last, helter skelter.  
*m n, m n, &c.* Galleries through the different stories. *k k k.* Lines of *plutz*. *m n n, &c.* Steps. *f g, &c.* Platforms.  
 The lines of direction from the top of the wall show the spaces protected by the *plutz*.

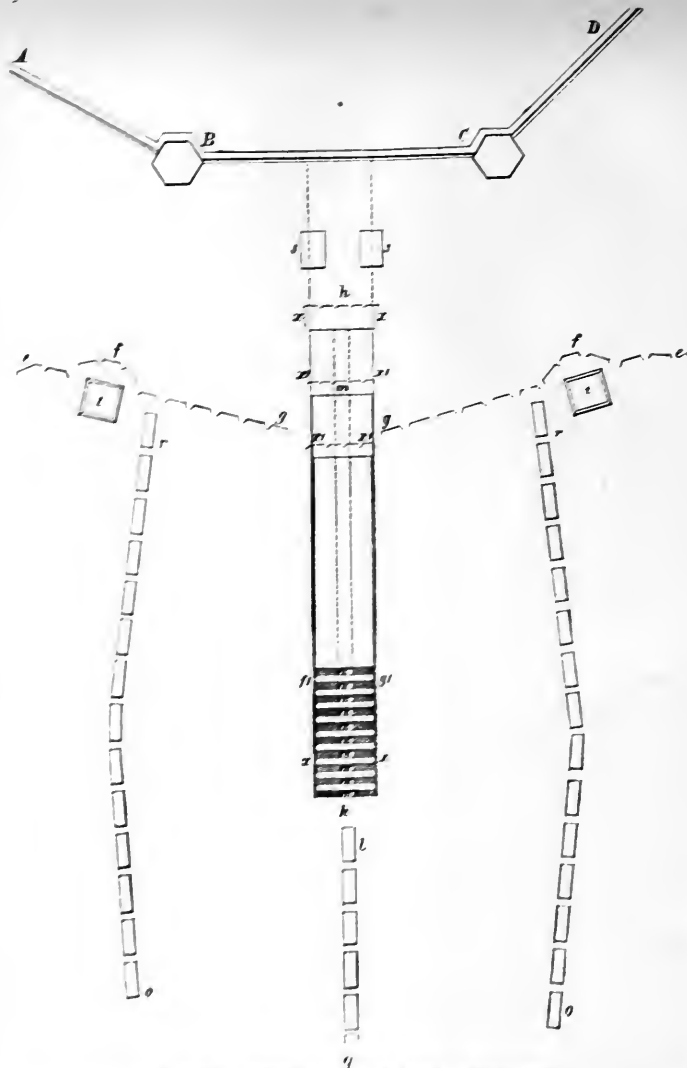

Fig. 25. General View of Siege Operations.

A B C D. Hostile wall. *t t*. *Testudines aggestitiae*, protecting those levelling the ground *h k*. *Agger*. *x x, x' x'*, &c. *Plutei*, protecting those working on the *agger* *e f g*. Line of *plutei*, manned with archers and slingers. *t t*. *Turres*, also manned with archers and slingers and provided with *tormenta*. *r o*. Covered way of *vineae*, giving approach to archers and slingers. *l g*. Covered way of *vineae* approaching the point *A* beginning the *agger*. *f g'*. Position of *plutei*, covering the beginning of *agger*. *m n*. Covered gallery through the *agger*. *u u u*, &c. Steps and platforms of the several stories.



the *agger*, and rushed along its summit to storm the enemy's works. Usually, however, the town surrendered when this assault was seen impending.

3. *vineas agere*, to push forward the sheds. — *quaeque* . . . *usui*, and to gather [the things] which were necessary (*usui*, dat., § 233; G. 350; H. 390. N. 2), &c., i.e. wood, earth, stones, &c.: the antecedent of *quae*, if expressed, would be *ea*. — *ad oppugnantum*: § 300 (cf. § 234. b); G. 433 (cf. 356. R. 3); H. 542. III. (cf. 391. II. 1).

4. *magnitudine*, by the great size of the works (i.e. by the extent of these offensive operations). — *quae*, which (i.e. the like of which). — *ante*, adv.

**42. petentibus Remis**, at the request of the Remi. — *ut conservarentur*: subst. clause of result, obj. of *impetrant* (§ 332; G. 557; H. 501).

CHAP. 13. *obsidibus acceptis*, after he had received as hostages the chief men, &c. — *Bellovacos*: their territory lay 40 or 50 miles due north of Paris.

2. *qui cum*, and when they. (A relative is often used to begin a new sentence where the English idiom would lead us to expect *et* and a demonstrative. The relative serves to bind the new sentence more closely to the preceding.) — *se suaque omnia*, themselves and all their possessions ("their all"). — *Bratuspantium*, Breteuil, at the head of the Somme valley. (Notice that *Bratuspantium* is in apposition with *oppidum*, contrary to the English usage.) — *circiter*, &c., [only] about five miles. — *millia*: § 257; G. 335; H. 379. — *passuum*: § 94. e; G. 308; H. 178 and N. — *majores natu*, the elders (§ 91. b; G. 89. 3; H. 168. 4). — *voce significare*, show by the tones of their voice (of course they could not talk Latin). — *in ejus fidem* . . . *venire*, that they entrusted themselves to his protection and power (i.e. "surrendered at discretion"): the clause is indir. disc., obj. of *significare*. (Notice that the reflexive *sese* refers to the speakers, and represents the first person of the dir. disc.: *ejus*, to *Cæsar*, the person spoken to.) — *neque*, and [that they did] not.

3. *cum* . . . *accessisset* . . . *poneret* (§ 325; G. 586; H. 521. II. 2), when he had arrived . . . and was pitching, &c.: observe

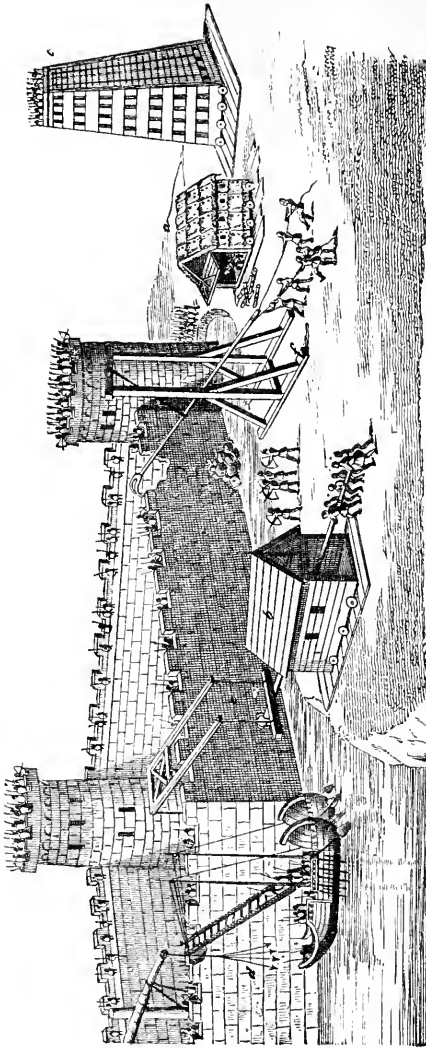

Fig. 26. *Oppugnatio.*

*a.* Testudo aggestitia. *b.* Testudo arietaria. *c.* Turris ambulatoria. *d.* Corvi. *e.* Harpago. *f.* Falx muralis.

NOTE. — This cut represents an attack both by land and water, in which no *agger* is employed. While in these respects unlike the attack on the Gallic towns, it shows very clearly some implements in active use.

the distinction of tenses. — **pueri mulieresque**, *women and children*. — **ex muro**: construed with **petierunt**. (The English says *on the wall*, from another point of view.) — **ab Romanis**: § 239. *e*. N. 1; G. 333. R. 2; H. 374. N. 4.

CHAP. 14. **pro**, *in behalf of*. — **eum**, i.e. Cæsar. — **facit verba**, *acts as spokesman*. — **Bellovacos**, &c.: the rest of this chapter is in indir. disc., depending on **facit verba**. — **omni tempore**, *always*. — **in fide atque amicitia**, *under the protection and patronage of* (i.e. they had been subject-allies (*amici*) of the Æduans). — **impulsos** (notice the emphatic position: *not* of their own accord but *induced* by their chiefs): agreeing with the subj. (of **defecisse**), which is to be supplied from **Bellovacos**. — **qui dicerent**: subord. clause in indir. disc., and therefore subjunc. (§ 336; G. 653; H. 524). **dicerent** introduces another clause in the indir. disc., — the statement of the chiefs, which is thus reported at second-hand by Cæsar as a part of the speech of Divitiacus. The subject is **Haeduos**; the verb, **perferre** (*that the Æduans were suffering*, &c.). [The chiefs said: **Haedui perferunt**, *the Æduans are suffering*.] — **omnes**, *all* [kinds of]. — **et . . . et**, *both . . . and*. — **defecisse . . . intulisse**, main verbs: the subj. acc. is supplied from **Bellovacos**.

3. **qui**, [those] *who*. — **principes**, *ringleaders in this design* (**consilii**, § 217; G. 361. 2; H. 396. III.). — **intellegent**, subord. clause in indir. disc. — **quantam . . . intulissent**, indir. question (§ 334; G. 462; H. 529. I.). — **civitati**: § 228; G. 346; H. 386. — **profugisse**: the subj. is **eos**, the implied antecedent of **qui**.

4. **suā clementiā**, *his own* [characteristic or well-known] *clemency* for the case, see § 249; G. 405; H. 421. I. — **utatur**: subst. clause of purpose, obj. of **petere** (§ 331. *a*; G. 546; H. 499. 3). Observe that from this point the pres. and perf. tenses of the subjunc. are used (by *Repraesentatio*).

5. **quod si fecerit**, *and if he does* (shall do) *this*: fut. conditional (“more vivid”). **fecerit** is perf. subjunc. (subord. clause in indir. disc.) for the fut. perf. indic. of the dir. disc. The apodosis is **amplificaturum**, which in the dir. would be **amplificabis** (§ 307. *a*; G. 597; H. 508. 2). — **quorum . . . consuerint**, *by whose aid and resources they are accustomed to withstand what*

*ever (si qua) wars befall them*: the antecedent of **quorum** is **Belgas**. — **auxiliis**, means. — **consuerint**, preteritive verb: see § 143. *c. n.*; G. 190. 5, 228. R. 1; H. 297. I. 2. — **si qua bella inciderint, sustentare consuerint**: general condition. Both clauses are here in the subjunc., because both are subord. clauses in indir. disc.; the protasis (**si inciderint**) is of course subord., and the apodosis (**consueverint**) is also subord. in this case because introduced by a relative (**quorum**). In the dir. disc., the sentence would run: **si qua . . . inciderunt, . . . consuevimus, if any** (= whatever) *wars befall, we are accustomed*. For the tense of **inciderunt**, see § 279. *b*; G. 569; H. 471. 5.

CHAP. 15. **honoris, Divitiaci . . . causa**, *out of respect for Divitiacus* (i.e. as a mark of respect to him) (lit. *for the sake of honor*). — **Divitiaci**, obj. gen. (§ 217; G. 361. 2; H. 396. III.). — **causâ**, abl. of cause (§ 245. *c*; G. 372, 407; H. p. 221. foot-note 2): used almost like a preposition with the gen., and always following its noun (here, **honoris**). — **recepturum [esse]**: indir. disc. for the fut. indic. (The fut. act. infin. commonly omits **esse**, as here). — **quod erat**: the indic. implies that this was the real reason, not merely one given by Cæsar at the time (which would require **quod esset**). — **magna auctoritate**, *of great influence* (§ 215. *n.*; G. 402. R.<sup>1</sup>; H. 419. 2): the gen. is more common. — **multitudine**: 253; G. 398; H. 424.

**43. 2. Ambianorum**, about *Amiens*, near the coast of the Channel.

3. **mercatoribus** (dat. of possessor, § 231; G. 349; H. 387), *traders have*. — **pati** (subj. **eos** understood), *that they suffer no wine, &c.*: the subj. acc. of the infin. in indir. disc. must regularly be expressed, but occasionally it is omitted when the sense is clear (§ 336. *a*; G. 527. R.<sup>2</sup>; H. p. 296. foot-note 2). — **nihil . . . vini**: § 216. *a. 1*; G. 371; H. 397. 1. — **relanguescere**: an inceptive verb (ending, **-sco**) (§ 167. *a*; G. 152. V.; H. 280). — **eorum**: this word is doubtful here, and is probably a note written by some ancient editor in the margin of his Ms. Without it, the clause expresses a general truth. — **animos, spirit.** — **remitti, is relaxed**.

4. **magnae virtutis**: § 215; G. 364; H. 396. V. Note that the gen. has exactly the force of an adj., so that it is even connected with **feros** by a co-ordinate conjunction (§ 154. a; G. 476; H. 554). — **Belgas**, obj. — **qui . . . dedidissent . . . projecissent**, *who* [they said] *had surrendered*, &c. . . . *and abandoned* (§ 341. d; G. 630; H. 528. 1). — **confirmare**, *they declared positively that they would neither*, &c. — **missuros . . . accepturos** [esse]: fut. infins. with subj. acc. **sese**, obj. of **confirmare**.

CHAP. 16. **triduum**: § 256; G. 337; H. 379. — **Sabim**: the *Sambre*, which flows northeasterly into the *Meuse* (Mosa). The Nervii occupied the basin of this river and of the upper *Scheldt*. — **non amplius milia**, &c.: § 247. c; G. 311. R.<sup>4</sup>; H. 417. I. N. 2.

2. **consedissee**, *had encamped* (in the dir. **consederunt**). — **expectare**, *were awaiting* (in the dir. **expectant**). — **Atrebatis**, &c.: small tribes to the south and west. — **his**: § 227; G. 345; H. 385. II. — **uti . . . experirentur**: subst. clause: § 332; G. 546; H. 498.

3. **expectari**: note throughout this indir. disc. the variation between pres. and perf. infins., according as the dir. disc. requires the pres. or perf. indic. — **qui-que**, *and* [those] *who* [not to be confounded with the pl. of **quisque**]; **qui**, as very often, implies its own antecedent, **eos**, obj. of **conjecisse**. — **in eum locum, quo**, *into a place, to which*, &c.: **quo** = **in quem**. — **esset**, rel. clause of result (characteristic): § 320; G. 633; H. 500. I. (The emphasis is shown in the following translation: "where on account of the MARSHES the *army* could not get access.")

CHAP. 17. **castris**: § 258. f; G. 387; H. 425. I. I. — **deligant** [Et. 440]: §.317; G. 632; H. 497. I. — **ex . . . Belgis**: for part. gen. (§ 216 and c; G. 371. R.<sup>5</sup>; H. 397. N.<sup>8</sup>) following **complures**, *very many of the Belgians*, &c. — **unā**, *along with him*. — **eorum . . . exercitus**, *the order of march of our army during those days*. — **eorum dierum** is gen. of quality (§ 215; G. 364; H. 396. V.), limiting **consuetudine itineris**; **exercitūs** is possess. gen. (§ 214; G. 361; H. 396. II.).

2. **demonstra[ve]runt**, *made known*. — **inter singulas legiones**, *between each two legions*. — **impedimentorum magnum numerum**, *a great number of baggage* [-animals] (i.e. *a very long baggage-train*).

THE BAGGAGE-TRAIN. — The heavy baggage (*impedimenta*) of the legion was carried by pack animals (*jumenta*), horses or mules. Wagons or carts, while occasionally used by the army, were more generally found only with the sutlers (*mercatores*), who followed the legions. The light baggage (*sarcinae*) was carried by the soldiers.

We may reckon the load of one pack animal at 200 pounds. First of all were the tents. These were described by Hyginus as square, 10 ft. on a side, with a wedge roof. Ten men could use such a tent. Hyginus estimates 8 men in a tent, but yet allows 1 to every 10, as  $\frac{1}{5}$  of each *contubernium* should always be on guard duty. It seems safe to consider that the *contubernium*, or number messing together in a tent, in Cæsar's army, was also 10. Then each centurion had one tent. So a maniple would need 14 tents for the centurions and a strength of 120 men. Allowing 2 for the servants, the entire number would be 16. That would make 48 for a cohort, and 480 for a legion. To this number must be added those needed by the six tribunes and their servants, or perhaps 12 more. If tents were allowed also for subcenturions, perhaps we should estimate 30 or 60 more.

The tents were of leather (*pelles*). The weight of one, including two upright poles, one ridge-pole, and a supply of pegs, must have been at least 40 pounds. One horse, then, could carry 5 such tents. It seems more likely, however, that we should estimate one pack animal to each tent; i. e. to each centurion and to each *contubernium*. In this way could be carried provisions for a week, with hand-mills, blankets, &c.

For pitching camp there must have been needed a full supply of stakes, tools, &c. As these were for general use, they could not have been divided among the pack animals of the cohorts. So we may add one animal to each cohort for this service. Thus the cohort would have at least 49 beasts. To each beast should be allowed one servant (*calo*), who could attend each to a centurion or *contubernium*.

The higher officers had, besides at least two riding horses each, a still greater number of pack animals. We shall not be far astray if we assign to each tribune three pack animals and five servants.

Thus the number of pack horses or mules in the baggage-train of a legion reaches at least 520.

**intercedere, intervened.** In the direct discourse: **magnus numerus intercedit.** — **neque . . . negotii, and that it was** [a matter] **of no difficulty** (lit. *and that it was nothing of difficulty*). — **negotii:** partitive (§ 216. a. 1; G. 371; H. 397. 1). — **cum . . . venissent**

. . . **abessent**: subjunctive, because subordinate clauses in the indirect discourse; the verbs refer to future time, and represent respectively the future perfect and the future indicative of the direct discourse. — **hanc**, i.e. the first legion. — **adoriri**: subject of **esse** (l. 32), **quicquam** being in the predicate. — **quā pulsā** . . . **direptis** (ablative absolute = protasis of a future condition), *if this should be routed*, &c. — **futurum** [esse], apodosis of the condition. — **ut . . . non auderent**, substantive clause of result, subject of **futurum** [esse] (§ 332. a; G. 558; H. 501. I. 1). — **futurum . . . auderent**, *the result would be that*, &c., is little more than a roundabout way of expressing the future infinitive (see § 147. c. 2; G. 240. 2; H. 537. 3).

3. **adjuvabat**: the subj. is **quod Nervii . . . effecerant**, *the advice of those who reported the matter was REINFORCED by the fact that the Nervii*, &c. Notice the emphatic position of **adjuvabant** (see Appendix, pp. 120, 121).

The following description of the march of a Roman army illustrates the plan of the Nervii, and will serve for reference hereafter: —

#### THE MARCH.

I. THE COHORT. — The cohort marched either in *column of maniples* or in *column of centuries*.

1. The column of maniples (*manipulatum*) was formed from order of battle merely by facing to the right (or left). (Figs. 27, 29.) Thus the maniples were in column, and the two centuries of each maniple were side by side. As the depth of the cohort in line of battle was 40 ft., of course the column of maniples was 40 ft. wide. But this was a loose order. Allowing each man 3 ft., the column could easily have been made only 30 ft. wide. Again, this wide column could have been reduced to half the width by the right (or left) century of each maniple moving straight on, and the other falling in its rear. Thus the maniple, instead of 12 ranks of 10 men, would have had 24 ranks of 5 men each. This last formation was really a *column of centuries by the flank*.

2. The *column of centuries* proper (*centuriatum, ordinatum*) was formed from the order of battle by having the maniple on the right (or left) wing of the cohort march straight forward, and the others successively followed (Figs. 27, 30, 31). Thus the centuries would form a column, the width of which would be the same as the front of a maniple, 40 ft. (or 36 ft., not including the centurion on the flank).

3. The column of centuries would naturally be adopted when a cohort marched directly forward. If the road was less than 40 ft. wide, as must often have happened in Gaul,\* the width of the column could easily be reduced from 40 ft. to 20 ft. The right (or left) half of each century would move straight on, and the other half would fall in its rear. The century would then consist of 10 ranks of 6 men each, instead of 5 ranks of 12 men. This was probably the usual formation in a march forward over the rough Gallic roads.

Fig. 30.

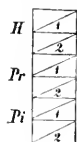
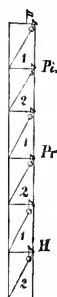

Fig. 31.



4. In column of march, in any formation, we should estimate 4 ft. as the distance from breast to breast. Then a cohort of 360 men would reach to the following length:—

In column of centuries, 120 or 240 ft.;

In column of maniples, 144 or 288 ft.

II. THE LEGION.—The legion, or a still greater number of cohorts, marched in one of three orders: in column (*agmen pilatum*), in order of battle (*acies instructa*), in square (*agmen quadratum*).

I. When the legion is in column, the cohorts march according to their number. If the march is from the right (i.e. from the right of the line of battle, Fig. 28), the first cohort has the lead, then follows the second, and so on. If the march is from the left, the 10th cohort leads, followed by the 9th, &c. Each cohort is in column of centuries. Between each two cohorts there must have been a small interval.

Fig. 27. Cohort in line of battle, facing towards A.

Fig. 29. Cohort marching by the right flank, in column of maniples.

Fig. 30. Cohort marching in column of centuries, the left (i.e. the Hastati) in front.

Fig. 31. Cohort in column of centuries, with five files.

NOTE.—In these diagrams, for convenience, the three maniples of the cohort are distinguished, in their order from right to left in the line of battle, by the terms that for many centuries served to distinguish them, long after the original meaning was lost: Pilani (Pi), Principes (Pr), and Hastati (H). The centuries in each maniple are numbered 1 and 2.

Suppose this to have been 20 ft. Then the length of the legion would have been 1400 or 2600 ft.

\* The Roman road was usually only 15 ft. wide.

Fig. 27.

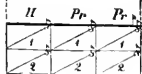
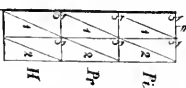

Fig. 29.





2. For the baggage-train of a legion, we estimate 520 pack animals as the normal strength. In a road 40 ft. wide, 8 animals can easily find room abreast. Then the train would have had 65 ranks. Allowing each rank 10 ft. depth, the train would extend 650 ft. In a road only 20 ft. wide, the pack animals would march 4 abreast, and would extend 1300 ft. Then a legion with its baggage in column of march would extend 2050 or 3900 ft.

Fig. 33.

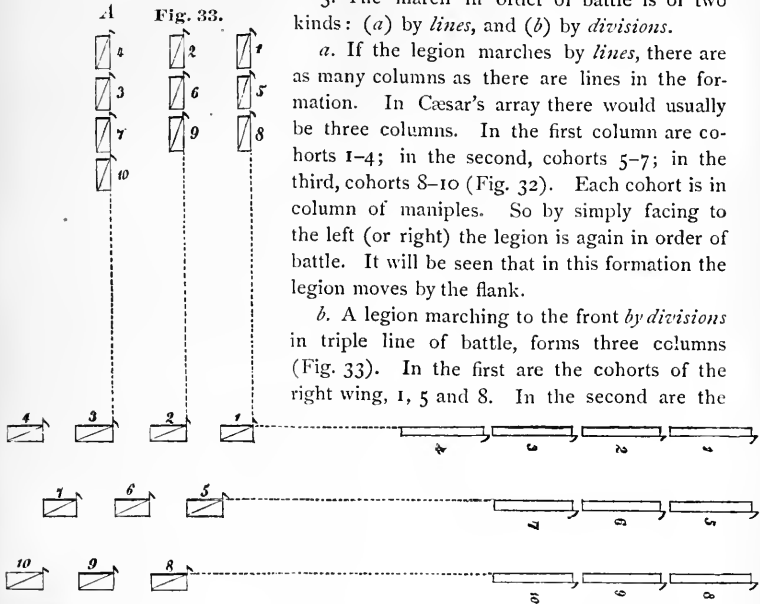

Fig. 28.

Fig. 32.

Fig. 28. The Legion in triple line of battle, facing towards A.

Fig. 32. The Legion marching by the right flank, in order of battle.

Fig. 33. The Legion marching to the front in order of battle.

cohorts of the centre, 2, 6 and 9. In the third are the cohorts of the left, 4, 3, 7 and 10. The columns must be as far apart as the distance between their leading cohorts when in line of battle. Each cohort is in column of centuries.\*

4. The march in square (Fig. 34) was used when the army was sur-

\* Bk. I. 49<sup>1</sup>, Bk. IV. 14<sup>1</sup>.

rounded by the enemy. One division of troops, in column of centuries, leads. Then follows the baggage-train, and then a second division of troops in column of centuries. On either wing marches a body in column of maniples. Then by a simple facing of the wings to right and left, and deploying of the van and rear, the square is ready to meet the enemy.\*

III. THE ARMY.—The three general directions of the march are, forward, to the rear, and to either flank.

1. When the column is marching forward, we must distinguish three parts of the army: the van (*primum agmen* †), the main body (*exercitus, omnes copiae, agmen legionum* ‡), and the rear guard (*agmen novissimum, agmen extremum* §).

2. The van may have had one of three objects. The first was to engage the rear of the enemy, so as to delay his march and give time for the main body to deploy, and for the commander to form his plans. For this purpose, a body of cavalry was sent forward, sometimes with the addition of light infantry (see Chap. 19<sup>3</sup>).

3. The second object was to reconnoitre the country (*loci naturam perspicere, iter cognoscere*), and to bring news of the enemy. To accomplish this, there were sent forward special detachments of cavalry (*exploratores*), who scoured the country far in front and on both flanks. To these detachments were often assigned trusty staff-officers, accompanied by spies (*speculatores* ||).

4. The third object was to select and make ready the place for the camp. This duty was entrusted to a detail of centurions from the legions, accompanied by a few men, and usually under a tribune or other officer of the general staff.\*\*

5. At a fixed distance after the van marched the main body, and close after it the rear guard. This last, during a march to the front, had only police duty to perform; i.e., to pick up stragglers, and the like.

6. The main body marched in one of three forms: *a*. In column, each legion accompanied by its baggage. *b*. In column, all the baggage of the army together. *c*. In line of battle.

*a*. This order of march was only adopted in a friendly country, or at

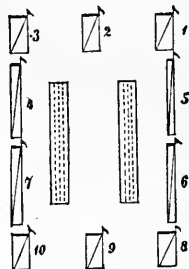

Fig. 34.

*The Legion marching in Square.*

\* Bk. VII. 67. † Bk. I. 15<sup>1</sup>. ‡ Bl. II. 19. § Bk. I. 15. 23, II. 26.

|| Bk. I. 15<sup>1</sup>. 21<sup>4</sup>. 41<sup>4</sup>, II. 5<sup>4</sup>.

\*\* Bk. II. 17<sup>1</sup>.

least when there appeared no immediate danger of an encounter with the enemy. The legions were in single column and the cohorts in column of centuries. Each legion was followed immediately by its baggage, which thus divided it from the legion next following. The last legion probably detached a few cohorts to follow the baggage. This detachment would thus form the rear guard of the whole army.

A column of five legions in this order, with a breadth of 40 ft., requires 10,250 ft. in length. A sixth legion would need 40 minutes to reach the head of this column so as to engage in battle.

It is clear that if the enemy could make a vigorous attack in force on the head of the column, they would have a good chance to throw it into confusion, and prevent it from properly deploying (see Chap. 17).

*b.* When near the enemy, if it was not desirable to march in order of battle, the column was formed as in *a*, but the baggage-train of all the army was assembled. The greater part of the legions, usually three-fourths of the entire number, composed the head of the column. Then followed the baggage. The remaining legions brought up the rear (*claudunt agmen*). In this order the legions could be deployed much more rapidly, and were properly called *expeditae* (see Chap. 19).

If a legion marching *expedita* is attacked on the march (*in agmine, sub sarcinis, in itinere*), before being able to meet the enemy, the legionaries must pile their personal baggage (*sarcinae in acervum comportantur, sarcinae conferuntur\**), draw their shields from their coverings (*tegimenta scutis detrahuntur †*), put on their field badges (*insignia accommodantur †*), put on helmets (*galeae induuntur, galeantur †*), and get their weapons ready (*arma expediuntur, legio armatur †*). Of course time was needed for all this; and this time must be won by the vanguard.

*c.* The advance in order of battle (*acie instructa*) could be made only for short distances. It was used only when in the immediate presence of the enemy, and when the ground was suitable. The order of march of each legion has already been described (see Bk. IV. Chap. 14<sup>1</sup>).

7. The march in retreat was usually in one of two forms: *a.* The retreat in column, with baggage massed. *b.* The retreat in square.

*a.* The baggage was sent out of camp as soon as possible, under escort of a detachment of infantry. This body formed the vanguard, and with them went a detail of centurions and privates to stake out the new camp. Then followed the main body, the cohorts in column of centuries. Finally, at a suitable distance, moved the rear guard (*agmen novissimum*).

\* Bk. I. 24<sup>2</sup>.† Bk. II. 21<sup>3</sup>.

‡ Bk. VII. 18.

It was the duty of these last to delay the enemy, thus giving the army time to push on, or to deploy, if the attack should be made in force. The rear guard was usually composed of cavalry, with archers and slingers.\*

*b.* The retreat in square was chosen when the enemy were on all sides; for instance, on a march through a rebellious country, and also when the hostile cavalry were numerous. A single square could be formed from all the legions, with all the baggage of the army in the centre; or each legion could form a square by itself, with its baggage enclosed. The cavalry, supported by the archers and slingers, remained without as skirmishers.†

*8.* Flank marches were made only for a short distance, and always in order of battle. The legions marched in column of lines, so that there were two or three parallel columns, according to the formation. The baggage-train would either march on the side remote from the enemy, or between the legions, each being followed by its own pack animals. The latter mode might be used when the army was divided from the enemy by some considerable obstacle, like a river; or when the side remote from the enemy was difficult to traverse; for instance, when the army was marching in the valley of a stream, so that the water was on the flank towards the enemy, and hills and woods on the other flank.‡ In such case as last mentioned, no guard of light troops would be necessary between the army and the enemy. But in open ground, such a detachment would have to be made, and would cover the march as skirmishers. To form line of battle from a column of march by the flank, was a simple matter unless the baggage was between the legions. It was done by facing to the right or left, as the case might be. In every march of a large body of troops, the order of march was changed daily, and the legions took turns in leading, so that each in turn might come first to camp.

**44.** *antiquitus*, adv.: the use of the hedges described below was an immemorial custom, and they are still, it is said, common in this region. Traces of such still exist in England, about 400 years old. — *cum*, causal. — *nihil* (adverbial) *possent*, *have no strength*. — *neque student*, *and they pay no attention*. — *quicquid* (adverbial) *possunt*, &c. = *all the strength they have is in infantry*.

*4.* *quo facilius* . . . *impedirent*, *in order to check the more easily* (§ 317. *b*; G. 545. 2; H. 497. II.). — *venissent*: § 342; G. 666; H. 529. II. — *teneris arboribus incisus*, &c., *by notching and bending down young trees and allowing their boughs to grow out*

\* Bk. I. 24<sup>1</sup>.

† Bk. VII. 67.

‡ Bk. VII. 34, 36.

*breadthwise, and by planting among them brambles and thorns, they had made these hedges furnish defences like a wall, which not only could not be broken into, but could not even be seen through.* — **ut . . . praeberent** (§ 332; G. 557; H. 501. II. 1): obj. of **effecerant**. — **instar muri**: § 214. *g*; G. 372; H. 398. 4. — **quo** (adv.), *whither* (i.e. *into which*). — **posset**, result clause. — **sibi**, dat. of agent.

CHAP. 18. **loci . . . quem locum**: § 200. *a*; G. 617; H. 445. — **castris**: § 233; G. 350; H. 384. 1. 3. The dat. of purp. of concrete nouns is used in prose in a few military expressions. — **aequaliter declivis**, *with even slope*. (Note the antithesis in **acclivitate**, below). — **quod** agrees in gender with **flumen**. — **vergebat**, imperf. of description (§ 277. *a*; G. 222; H. 469. 1.).

2. **ab**: i.e. on the other side. — **pari acclivitate**: § 251; G. 402; H. 419. II. — **adversus . . . contrarius** = *facing this, and on the other side* (of the stream). — **huic**: § 234. *a*; G. 356; H. 391. I. — **passūs** (§ 257; G. 335; H. 379) **apertus**, *cleared* (of woods) *at the foot for about 200 paces, or 300 yards*. — **infimus**, *at the foot* (§ 193; G. 287. R.; H. 440. 2. N. 2). — **ab superiore parte** (§ 260. *b*; G. 388. 2; H. 434), *in the upper portion*. — **ut non**: § 319. *d. R.*; G. 554; H. 500. foot-note 1.

3. **secundum** (prep.), *along or near*. — **stationes equitum**, *cavalry pickets*. — **pedum trium**: gen. of measure (§ 215. *b*; G. 364. R.; H. 396. V., 402), here in the pred.

CHAP. 19. **copiis** (without **cum**): § 248. *a*; G. 401. R.; H. 419. iii. 1. — **ordo agminis**, *plan of march* (**ago**). — **aliter ac**, *was different from what the Belgæ had reported* (lit. *had itself otherwise* [than] *as*): § 156. *a*; G. 646; H. 459. 2. — **ad Nervios**: § 225. *b*; G. 334. R. 1; H. 386. 3.

2. **hostis**, acc. pl.: § 55. *c*, 58; G. 60. 1; H. 62. This form is constantly found in earlier writers, and must have been common throughout the Republican Period; but it is rare in most editions of Cæsar. — **consuetudine suā** (abl. of manner), *in accordance with his custom*. — **expeditas**, *unincumbered* (without baggage). — **ducebat**: for the order of march, see note, pp. 97-102. — **conlocārat**, *had put in place* [of greatest safety]: this verb (**colloco**) is often confounded by beginners with **collego**, *collect*. — **inde**, *then, next*. — **proxime conscriptae**, *latest levied*; while the veterans,

must bear the brunt of the fight. — *praesidio impeditis*: § 233; G. 350; H. 390. I.

TACTICS OF THE CAVALRY. — The small tactical unit\* of the Roman cavalry, or of that formed on the Roman plan, was the *turma* of 32 horses in rank and file. This was probably arranged in 4 ranks of 8 horses each. Allowing 5 ft. front room to each horse, the *turma* would have a front of 40 ft., equal to that of the maniple. Taking 10 feet depth for each rank, the depth of the *turma* would also be 40 ft., again equal to that of the maniple. The order of march could easily be formed from this order of battle.

A regiment (*ala*) of 400 horses consisted of 12 *turmae*. The battle array of the cavalry would very likely resemble that of the infantry. It would then consist of several lines, two or three, with intervals between the *turmae*. A regiment of 12 *turmae* in two lines would have 6 in each line; and the front, including intervals, would be 440 ft. Of course, if it should be desired to overwhelm the enemy with the momentum of the mass of horse, the intervals would be closed up.

If the number of cavalry should be considerable, a larger tactical unit would be desirable. Three *turmae*, arrayed side by side, would amount to about 100 horses, with a front of 120 ft., equal to that of a cohort. A regiment (*ala*) of 400 horses would contain 4 such divisions.

In attacks in mass doubtless columns were formed of entire *alae*, perhaps 3 *turmae* front and 4 *turmae* (i.e. 16 ranks) deep. After the success was won, the *turmae* in the rear could be brought to the front (*turmatini*) to pursue the scattered foe.

Of course, the tactics of the cavalry would depend largely upon their arms as well as upon their numbers. If provided with missiles, they would doubtless be arrayed in *turmae* only, and would never form columns for attack.

The usual order of march of the *ala* of 400 men was probably in columns of *turmae*. If there was room for a column 40 ft. wide, the normal order of battle might be kept by each *turma*. The *ala*, not including the train, would then extend 480 feet. The train must have been considerable, and would have added at least a half to the length of the line. A column of 10 *alae*, or 4000 men, which Cæsar sometimes had, would have extended 7200 feet.

\* By a *tactical unit* is meant a body of troops which act together, and on which the evolutions of a larger body are based. Thus, in the American army, the company is the tactical unit of the regiment; the regiment of the brigade, &c.

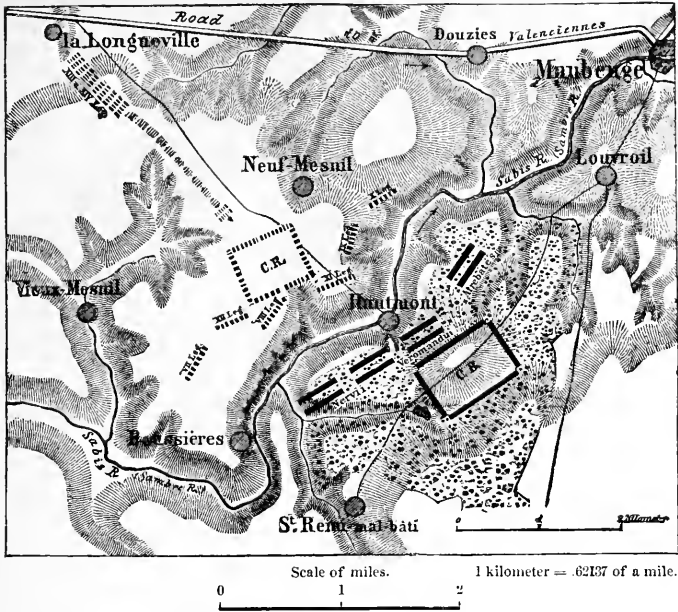

Plan V. *Battle on the Sambre (Sabis)*. Bk. II. Chap. 19-27.

C. R. Castra Romana.

C. B. Castra Belgica.

If the road allowed the column a breadth of only 20 ft., as must generally have been the case in Gaul, the *turma* would march with a front of 4 horses and a depth of 8. The *ala* would then need 960 ft., without baggage, and with it 1440 ft. A column of 10 *alae* would require 14,400 ft.

In camp there would suffice for each *turma* a space of 120 ft. by 30 ft., the same as for a century of infantry. Then one *ala* of cavalry would take the same room and be arranged in the same way as two cohorts of infantry. Of course, in particulars the arrangement must have been varied to adapt it to the convenience of that arm of the service.

4. *cum, while*. — *reciperent . . . facerent, kept retiring, &c.* (strengthened by *identidem*). — *quem ad finem*: the antecedent attracted to the rel. clause. Translate as if it were *ad finem ad*

*quem*, farther than to the limit up to which the open ground extended. — [eos] *cedentes*, them in their retreat: *cedentes* agrees with *eos*, the understood obj. of *insequi*. — *opere dimenso*, having staked out the works.

**45.** 5. *ubi . . . visa sunt*: § 324; G. 563; H. 518. — *quod tempus*, the moment which. — *committendi proelii*: depending on *tempus*. — *convenerat* (impersonal), had been agreed upon: cf. English *conventional*. — *ut . . . confirmaverant*, just as they had formed their line and had encouraged one another, they dashed forward (*provolaverunt*), i.e. in the same order and with the same resolute courage.

6. *ut*, so that (result). — *in manibus nostris*, lit. in our hands (i.e. within reach of our weapons). — *adverso colle*, &c., pushed straight up the hill (§ 258. g; G. 387; H. 431, according to Professor Harkness). — *eos*: after *ad*. — *occupati*, still at work on the fortifications (*in opere*): *occupatus* is always used as an adj.

CHAP. 20. *Caesari*, dat. of agent (§ 232; G. 352; H. 388). Notice the emphatic position of *omnia*. *Cæsar* had to do *everything* at one time. — *erant agenda*, had to be done. — *vexillum*: see note on Bk. I. Chap. 25. — *proponendum . . . dandum*, &c.: second periphrastic, like *erant agenda*. — *concurri*, impersonal passive (§ 146. c; G. 199. R. 1; H. 195. II. 1).

THE MARTIAL MUSIC. — The musical instruments used in the Roman army were four in number: 1. The *buccina*, or bugle, a winding-horn of brass. 2. The *cornu*, or horn, the horn of an ox, with a silver mouthpiece. It was also sometimes made of brass. 3. The *tuba*, or trumpet, straight and otherwise like the modern trumpet. 4. The *lituus*, or cavalry trumpet, bent at the mouth, and distinguished by its shrill tone.

The only musicians expressly mentioned by *Cæsar* were the *buccinatores* and *tubicines*. The former seem to have used both bugle and horn; the latter, only the trumpet. The various evolutions of the legion and its component parts were regulated by horn and trumpet, — the orders of the commander being first signalled on the former, and then passed along the line by the hoarse blast of the trumpet. It seems likely that there was a horn for each cohort, and a trumpet in each manipule. The *classicum*, sounded by all the musical instruments at once, was the general's call for the army to assemble when he wished to address them; or it was the



Fig. 35. *Lituus*.Fig. 36. *Tuba*.Fig. 37. *Buccina*.

signal for the onset to begin. In the latter case the commander's standard (*vexillum*) was first displayed. This was immediately followed by the simultaneous blast of horn and trumpet. At this the soldiers raised the war shout (*clamor*) and rushed to the charge. They had previously been advancing at a slow step.

The various divisions of the day, *veille*, noon and tattoo, were sounded by the bugle (*buccina*); each signal being followed, quite likely, by a martial air played by the assembled musicians of the army.

**paulo longius**, to a considerable distance: for this use of the compar., see § 93. *a*; G. 312; H. 444. I. **paulo** is abl. of degree of difference (*by a little*), used as an adv. — **aggeris petendī causā**, for the purpose of gathering material for the rampart (wood, sods, &c.). — **qui** relates to subj. of **arcessendī** [erant]. — **cohortandī** (passive), had to be encouraged (§ 135. *d*; G. 243; H. p. 114. foot-note at end). — **signum dandum**, i.e. the signal for the onset: the previous signal (**signum tuba dandum**) was for the soldiers to fall in, — to form their ranks. — **successus**, close approach.

2. **difficultatibus . . . subsidio**: § 233; G. 350; H. 390. I. — **usus**, experience. — **quid . . . oporteret**: indir. question, obj. of **praescribere**. — **quid fieri**: infinitive clause, subj. of **oporteret**. — **quam** connects similar constructions (§ 208. *a*). — **quod**, because, &c. (the second of the two things mentioned). — **singulis**, &c., had forbidden the several lieutenants to leave the work and their several legions. — **discedere**: § 331. *a*; G. 532. R.<sup>1</sup>; H. p. 310. foot-note 1. — **nisi munitis castris** (abl. absolute), not unless the camp had been fortified, but unless when the camp had been fortified

(i.e. *not until after*, &c.): the full construction would require **nisi munitis castris discederent**.

3. **nihil iam expectabant**, *no longer waited for any orders from Cæsar*: **nihil** (adverbial acc., § 240. a; G. 331. R. 2; H. 378. 2) is stronger than **nōn**; for **nihil iam**, see § 151. b.—**quae videbantur**, *what seemed best*.

CHAP. 21. **necessariis**, i.e. such as were (absolutely) *necessary*.—**ad cohortandos milites**, gerundive of purpose.—**quam in partem** = **in eam partem in quam**, *to whatever division it happened* (chance brought).—**decumam** = **decimam** (§ 12. c): cf. Bk. I. Chap. 41.

2. **non longiore . . . quam ut**, *with no more words than that they should*, &c.—**retinerent, perturbarentur, sustinerent**, purpose.—**neu** = **neve**, *and not*.—**quam quo . . . posset**, rel. clause of characteristic: § 320. c; G. 313; H. 503. II. 3.

46. 3. **pugnantibus** (sc. **eis**, § 228; G. 346; H. 386) **occurrit**, *finds them* (already) *fighting*.—**paratus** (adj.) **ad dimicandum**, *ready for battle* (lit. *fighting*).—**ad insignia adcommodanda**, *for fitting on the decorations* (of the helmets, &c.). Some of these indicated the rank of the wearer (see p. 3 of notes). Perhaps, too, the different legions were distinguished by the *insignia* of the helmets.—**scutis** (§ 243; G. 344. R. 2; H. 414. N. 1), &c., *for taking the covers (tegimenta) off the shields*: on the march helmets were slung upon the breast, shields covered with leather, and ornaments kept in some unexposed place.—**defuerit**, *failed, was wanting* (there was not time enough to, &c.): for tense, see § 287. c; G. 513; H. 495. VI.

4. **quam in partem**, *to whatever place*.—**ab opere**: i.e. from his position in the work of fortifying.—**quae-que**, &c., *and whatever standards he saw first* (**prima**, adj. with **signa**), *by these he fell in* (took his stand): the Roman soldier was so well drilled, that, to whatever part of the legion he found his way, he knew perfectly the duties belonging to it.—**haec (signa)**: antecedent to **quae**, but implying also the antecedent (**in hac parte**) of **quam** above.—**in quaerendis suis** (§ 301; G. 434; H. 544. 2), *in hunting up his own position* (lit. *his own standards*).

CHAP. 22. *ut, as.* — **dejectus** (noun), *the steep decline.* — **quam ut . . . postulabat**, *than as the system and method of military science required.* The military science of the ancients was adapted to level, open ground, in which the troops could be drawn up and kept in regular lines. — **cum**, causal. — **diversis legionibus** (abl. absolute), *the legions being scattered* (and so not supporting one another, see Plan V.). — **aliae aliā in parte** (§ 203. *c*; H. 459. 1), *some in one position, some in another.* — **sepibus . . . interjectis**, *thick hedges being in the way* (and so breaking up the ground). — **ante**: i.e. in Chap. 17. — **impediretur**: connected with **resisterent** by **-que** in line 13. — **neque**: here begins the main clause, the verb of which is **poterant**. — **certa subsidia**, *regular reserves.* — **quid . . . opus esset** (§ 243. *e. R.*; G. 390; H. 414. IV. N.<sup>4</sup>), *nor could what was needed everywhere (in each place) be foreseen [and so] provided for.* — **provideri**, compl. infin. with the **poterat** supplied from **poterant**. The subj. of this **poterat** is the indir. question (§ 334. head-note; H. 529. I.) **quid . . . opus esset.** — **ab uno** (emphatic), *by one man.* — **administrari**, *be attended to.* — **in tanta rerum iniquitate**, *in such an inequality of circumstances.* — **fortunae**: emphatic, set off against **rerum**. The *circumstances* were diversified; the *fortune* that attended them consequently had various results. — **eventūs** (nom. pl.), subj. of **sequebantur**.

CHAP. 23. *ut, when*: the clause is nearly equivalent to an English participle, *having taken up their position* (cf. § 290. *d*). — **acie**, gen. (§ 74. *a*; G. 69. R.<sup>2</sup>; H. 120). — **pilis emissis**: see note on Bk. I. Chap. 24, "The Order of Battle." — **cursu . . . exanimatos**, *out of breath with running, &c.* — **exanimatos**: acc. with **Atrebates** (obj. of **compulerunt**). — **conantes**, acc. — **impeditam**, *embarrassed* (in their attempt to cross).

2. **ipsi**: referring to **milites**, l. 20. — **progressi**, *and having advanced upon unfavorable ground* (i.e. continuing the charge up the hill on the other side of the river). — **rursus resistentes hostes**, acc.

3. **diversae**, *different.* — **ex loco superiore**: i.e. starting from, &c. — **in ripis** modifies **proeliabantur** (*continued the fight*).

4. **totis**: emphatic position (cf. Eng. "exposed almost *entirely*"). — **a fronte**, *in front* (§ 260. *b*; G. 388. R. 2; H. 434. I.). — **nudatis**, *being exposed* (by the absence of Legions VIII, IX, X, XI). Legions

VIII and XI were a *fronte*; IX and X, *ab sinistra parte*; and VII and XII, in *dextro cornu*. — *constitisset*: causal, showing why the enemy charged in that quarter. — *magno intervallo*: § 250; G. 400; H. 423. — *confertissimo agmine*, abl. of manner.

**47.** *quorum*, partitive. — *aperto latere*, on the uncovered flank (the right, not protected by shields): for omission of prep., see § 258. *f*; G. 386; H. 425. 1. — *legiones*: the 12th and the 7th. — *castrorum*, not partitive, the highest part of the camp, but possess., the height of the camp (i.e. on which the camp stood). — *petere*, to make for.

CHAP. 24. *levis armaturae*, descriptive gen.: note how it is naturally translated by a descriptive adj. (*light-armed*) in English (cf. Chap. 15.<sup>4</sup> note). — *unā*, adv. — *pulsos* [esse]: infin. of indir. disc., with subj. acc. *quos*. — *adversis hostibus*, &c. (§ 228; G. 346; H. 386), *met the enemy face to face*. — *occurrerant . . . ferebantur*: these *descriptive* imperfs. (§ 277. *a*; G. 223; H. 471. 6) belong to the side action interrupting the main narrative, which is resumed in the perfs. *contenderunt*, &c., at the end of the chapter. — *aliam in partem*, in another direction.

2. *summo*: § 193; G. 287. R.; H. 440. N. 2. — *nostros . . . transisse*, that our men had crossed the river (indir. disc.) *victoriously* (as victors). — *cum respexissent*, on looking back. — *versari*, were busy (indir. disc.). — *praecipites*: adj. with adv. force (§ 191; G. 324. 6; H. 443), agreeing with *calones*.

3. *alii alium*: § 203. *c*; G. 321; H. 459. 1. — *perterriti*, frantic with fear, *panic-stricken* (thoroughly frightened): observe the force of *per-* (§ 170. *c*. and N.; H. 344. 5).

4. *quorum* (possess.) *virtutis* (objec.) *opinio*, whose reputation for valor (§ 217. *b*). — *ab civitate*, abl. of agent: the state being thought of as a voluntary agent. — *multitudine*: § 248. *c*; G. 389; H. 421. N. 1. — *compleri* (*was filling*) . . . *premi* . . . *teneri* . . . *fugere*: indir. disc., with *vidissent*. The pres. tenses indicate what they saw *going on* before their eyes (dir. *complentur* . . . *premuntur* . . . *tenentur* . . . *fugiunt*. (The beginner should notice that difference of idiom requires a change of tense in translation.) — *desperatis nostris rebus*, despairing of our success. — *domum*:

§ 258. *b*; G. 410; H. 380. 2. 1. — **pulsos superatosque** [esse]: indir. disc.; the subj. is **Romanos**. — **castris**: § 249; G. 405; H. 421. I. — **hostes**: acc., subj. of **potitos** [esse], *had got possession of*.

CHAP. 25. **Caesar**: subj. of **processit**.

Notice that the main verb of the sentence is not expressed until all the attendant circumstances, &c., have been introduced in the form of modifying phrases, dependent clauses, &c. Thus the sense and construction are *suspended*. Such a sentence is called a *Period* (§ 346; G. 685, 686. 2; H. 573). An English writer would have used several short, independent sentences, each describing a single act or circumstance.

**ubi**: construe with **vidit**, line 28. — **sibi . . . impedimento** (§ 233; G. 350; H. 390), *hindered one another in fighting* (were for a hinderance themselves to themselves for the fight).

2. **quartae cohortis**: this stood on the left of the front line (see note on Bk. I. Chap. 24), and so bore the brunt of the attack. — **omnibus centurionibus occisis**, abl. absolute (so four times in the following four lines). — **signo**: evidently this refers to the standard of the *cohort* (see note on Bk. I. Chap. 25). This passage shows that the cohort had a standard, probably that of the first maniple. — **in his**, *among these*. — **primipilus**: the **primus pilus** (**primipilus**) was the first centurion of the first cohort, and thus stood at the extreme right of the line. As an officer of the legion he ranked next to the military tribune. (See note on Bk. I. Chap. 7). — **ut, so that**: result. — **iam non, no longer** (§ 151. *b*).

3. **tardiores, rather slack** (discouraged) (§ 93. *a*; G. 312; H. 441. 1). — **ab novissimis, in the rear** (§ 260. *b*; G. 388. R. 2; H. 434. I.): so below, § 3. Of course he came up to the rear of the legion first. — **deserto proelio, withdrawing from the fight** (abl. absolute). — **hostis, acc. pl.** (see note on Chap. 19<sup>2</sup>): subj. of **intermittere**. — **neque** (correl. to **et**, p. 48, line 1), *that the enemy did not cease coming up, but (et) were pressing on (instare)*.

48. **in angusto, in a strait**. — **vidit**: repeated from line 4 of this chapter, on account of the length of the sentence. — **posset**, rel. clause of characteristic (§ 320; G. 633; H. 503. I.).

4. **militi**: dat., after **detracto** (§ 229; G. 344; H. 385. 2). — **signa . . . laxare**, to charge (bear on the standards), [and thus] *open out the maniples*. In this manœuvre the odd numbers of the front rank sprang forward against the enemy, and thus gained twice the room they had in the crowded ranks for the use of the sword. (See note, Bk. I. Chap. 24, p. 37 of Notes.) — **quo . . . possent**: § 317. *b*; G. 545. 2; H. 497. II. Each soldier appears to have needed a space of about three feet square.

5. **militibus**, dat., with **inlata**. — **etiam . . . rebus**, *even in his own extreme peril*. — **operam navare**: § 331. *b*; G. 532; H. 535. II. and foot-note. (The beginner should beware of confounding **opera** with **opus** or with **ops**. See Vocabulary.)

CHAP. 26. **constiterat** (from **consisto**), NOT *had stood*, but *had taken up a position, had formed*: see Vocabulary. — **urgeri**, *hard-pressed*. — **ut conjungerent . . . inferrent**: subst. clause, secondary obj. of **monuit** (§ 331; G. 546; H. 498. II.). — **conversa**, &c., *should charge the enemy in opposite directions* (lit. *bear turned standards against*). The two united, facing different ways, thus forming a circle (**orbis**) or a hollow square (see note, Bk. IV. Chap. 37<sup>2</sup>). This movement made it necessary to *face about*.

2. **alii**: dat., after a verbal phrase of *helping* (§ 227; G. 346; H. 385. I.). — **neque timerent**, *and no longer feared*. — **ne . . . circumvenirentur**: § 331. *f*; G. 552; H. 498. III. — **aversi**, *in the rear* (while their backs were turned). — **ab hoste**, *by the enemy* (collectively, in which sense the pl. is more common).

3. **praesidio impedimentis**, dat. *for* which and dat. *to* which. — **cursu incitato**, *setting out on a run*.

4. **gererentur**: § 334; G. 462; H. 529. I.

5. **esset**, indir. question. — **nihil . . . reliqui** (partitive gen.) **fecerunt**, *left nothing undone in the way of speed* (i.e. *hastened as fast as they could*).

CHAP. 27. **etiam qui**, *even* [those of them] *who*. — **procubissent**, subj. of characteristic (§ 320; G. 633; H. 503. I.) or of integral part (§ 342; G. 666; H. 529. II.). — **scutis**, locative abl. (§ 254. *b*; G. 403. R. 3; H. 425. I. I. N.). — **inermes armatis**, [though] *unarmed, threw themselves upon the armed* [enemy]. — **occurrerent**: result, like **redintegrent** above and **praeferrent**

below. — **ut delerent**, pure purpose clause, dependent on **praeferrant**. — **pugnant quo**: probably spurious; to be disregarded in translation. — **se . . . praeferrant**, *showed themselves superior to*.

2. **tantam virtutem praestiterunt**. On this clause depend the following subjuncts. (of result): **insisterent**, **pugnarent**, **conicerent**, **remitterent**.

**49. primi, foremost**. — **jacentibus** (sc. **eis**, abl. after **insisterent**), *trod upon them as they lay fallen* (lit. *them lying*).

3. **his dejectis**, &c. (abl. absolute), *and that, when these too were struck down, and corpses were piled in heaps, those who survived still hurled weapons against our men as if (ut) from a mound*. — **qui superessent**, characteristic clause. — **ut . . . deberet**, *so that it must be judged that not without good hope of success (nequiquam) did men*, &c. **ut . . . deberet** is a result clause, dependent on the whole of the preceding sentence. The subj. of **deberet** is the infin. clause **homines** (acc.) **ausos esse. judicari** is complem. infin. with **deberet**. The other infins., **transire**, **ascendere**, **subire**, are complementary to **ausos esse**. — **facilia**, pred. accusative.

CHAP. 28. **prope ad interneccionem**: the Nervii were not by any means exterminated. Three years later they revolted again (Bk. V. Chap. 39), and two years after that they sent a force of 5000 men to Alesia to relieve Vercingetorix (Bk. VII. Chap. 75). — **aestuaria**: the country lying to the north (the modern Zealand) is low and marshy, cut up with bays and tidewater inlets. — **conjectos**: sc. **esse**. — **hac pugnā nuntiatā**, *when the news of this battle reached them*. — **cum**, causal. — **impeditum**, &c., *there was no obstacle in the way of* (lit. *nothing hindered to*) *the conquerors, and no safety* (lit. *nothing safe*) *for the conquered*.

2. **in . . . calamitate**, *in reporting the loss*. — **qui . . . possent**: § 320; G. 633; H. 503. I.

3. **usus** [esse], personal construction: § 330. b; G. 528; H. 524. I. N. I. — **misericiordiā** (abl.), *mercy*: it has been observed that Cæsar's dealings with the Gauls were comparatively merciful at first; at least, after an enormous massacre, the remnant had something to hope for. But after he had been twice repulsed from Britain, when Gaul made another effort for independence, his "gentleness" was

shown by such acts as cutting off the hands of all who had borne arms (Bk. VIII. Chap. 44), and in the treatment of Vercingetorix, — kept for years in chains, and then killed in cold blood at his conqueror's triumph. — *ut . . . videretur, that he might be seen (NOT seem) to have used mercy.* — *ut . . . prohiberent*: subst. clause of purpose, obj. of *imperavit* (§ 331. *a*; G. 546; H. 498. I.). (Compare this construction with that of *uti jussit* in line 22.)

CHAP. 29. *cum . . . venirent, while on the way.* — *omnibus copiis*: § 248. *a*; G. 391. R. I; H. 419. I. I. — *auxilio* (dat. of purpose) *Nerviis* (dat. of person): § 233; G. 350; H. 390. — *oppidum*: probably opposite *Namur*, at the confluence of the Meuse (or Maas) and Sambre. (For a striking description of the locality, see Motley's *Dutch Republic*, III. 224.) Others place it at *Falhize*, opposite Huy, on the Meuse below Namur.

2. *cum, while.* — *ex . . . partibus, all round* (lit. *from all sides in its circumference*). — *despectūs*, acc. pl. — *pedum*: § 215. *b*; G. 364. R.; H. 396. V. — *collocabant*: notice the change of tense. — *saxa . . . trabes*: to throw down on the besiegers.

3. *ex Cimbris Teutonique*: abl. of source (§ 244. *a*. Rem.; G. 395; H. 415. II. N.). (See note on Bk. I. Chap. 7<sup>4</sup>.)

50. *impedimentis* (abl. absolute) refers to cattle as well as articles of baggage; hence the two verbs, *agere* (*to drive*) and *portare* (*to carry*). Compare *ferre et agere* (*to plunder*). — *custodiam, a guard*, whose duty it was to keep an eye on the baggage, &c.; *praesidium, a garrison*, who were to hold the place. — *sex milia*: this Teutonic military colony was probably merely adopted into the Celtic tribe of the Aduatuci, thus giving rise to the story that the whole tribe were of Teutonic descent. — *unā* (adv.), *along with* (the baggage and cattle, — the *impedimenta*).

4. *Hi*: i.e. the six thousand. — *eorum*: i.e. the Cimbri and Teutons. — *obitum*: *destruction*: the Teutons were totally defeated by Gaius Marius at *Aquæ Sextiæ* (*Aix les Bains*), B.C. 102; the Cimbri, by Marius and Catulus, next year, at *Vercellæ*. — *alias* (adv.) . . . *alias, now . . . now.* — *inferrent, made*: the regular word for offensive war. — *inlatum [sibi] defenderent, defended themselves when attacked* (lit. *warded it [sc. bellum] off [de-fendo] when made against them*). — *consensu eorum omnium, by mutual*



*agreement* (by a compact with them all, i.e. the *finitimi*). — *sibi domicilio*: § 233; G. 350: H. 390. — *hunc locum*: the land between the Meuse and the Scheldt.

CHAP. 30. *adventu*: abl. of time. — *faciebant*: notice the tense. — *parvulis*: for the formation of the word, see § 164. *a*;

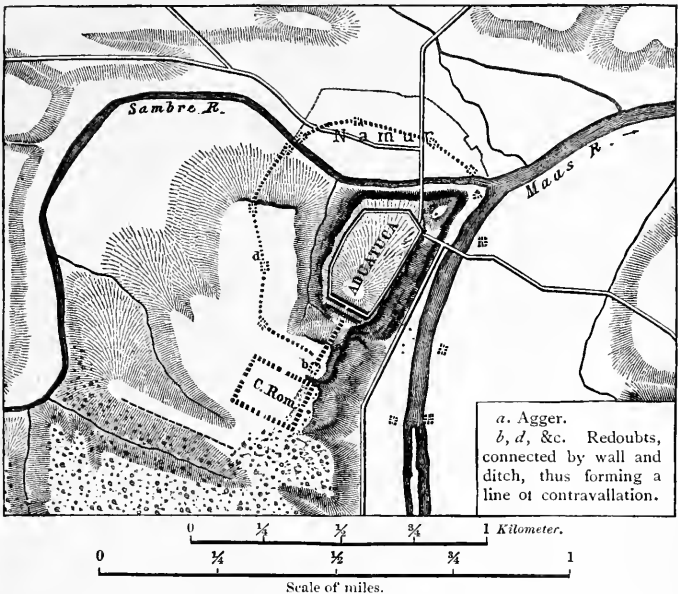

Plan VI. *Siege of Aduatuca*. Bk. II. Chap. 29-33.

G. 786. 9. *b*; H. 332. — *pedum XII*: i.e. in height. — *XV milium*: fifteen miles (sc. *passuum*) would be preposterous for so small a hill; hence Napoleon III understands *pedum* instead of *passuum*. But this would be nearly three miles; and the works, on his plan, measure hardly more than one. — *oppido*: *in* is not used, because the idea of *means* is present to the writer's mind.

2. For the siege operations, see note, "The Siege," pp. 85-90, and illustration, p. 92. — *constitui*: indir. disc., dependent on

**viderunt.** — **inridere**, historical infin.: § 275; G. 650; H. 536. 1. — **ab tanto spatio**, *so far off* (lit. *away by so great a space*): abl. of degree of difference. **Ab** is an adv. here.

3. **quibusnam**, &c.: the enclitic **nam** gives a sarcastic emphasis to this jeering question of the barbarians, *by what hands, pray, or what strength?* — **prae**, *in comparison with*. — **contemptui**: § 233. N.<sup>1</sup>; G. 350; H. 390. — **conlocare**, indir. disc.: we should have expected the future (**conlocaturos** [esse]). Apparently the Gauls thought the Romans meant to lift the tower and set it up on the wall (**in muro**); and such an idea, of course, seemed very funny. But when the tower began to increase in height and to roll forward (see note on Chap. 12, "The Siege," 3), the joke lost its point.

CHAP. 31. **moveri**, *that it was actually moving* (lit. in pass.): for the omission of the subj. acc. **turrim**, see § 336. a; H. p. 296, foot-note 2. — **locuti** (participle), *speaking*.

2. **existimare** (sc. **se**), *that they thought*: depending on **locuti**. — **tanta celeritate**: § 248. R.; G. 401; H. 419. III. — **possent**, causal: § 320. e; G. 636; H. 517. — **se** (obj.) . . . **permittere**, *that they surrendered themselves*, &c.: depending on **dixerunt**.

3. The indir. disc. is continued. — **unum**: notice the emphatic position. — **deprecari**, *besought* (i.e. to be spared: **de-precor**, *to beg off*). — **pro sua**, &c., *in accordance with his usual* (or *well-known*), &c. — **quam** . . . **audirent**, *which they were* [all the time] *hearing of*: repeated action. — **statuisset**: for the fut. perf. (**statueris**) of the dir. disc. (§ 307. c; G. 597; H. 473. 2). — **conserandos**: § 331. d. — **ne** . . . **despoliaret**: subst. clause of purpose, in apposition with **unum**.

4. **inimicos**: i.e. their neighbors (cf. line 5, above), regarded them as interlopers. — **virtuti**: § 227; G. 346; H. 385. II. — **traditis armis** (= **si arma tradita essent**): abl. absolute, equivalent to a protasis (§ 310. a; G. 594. 2; H. 431. 2). [In the dir. disc.: **si arma tradita erunt, non poterimus.**]

5. **sibi praestare**, *that it was better for them* (impersonal; dir., **nobis praestat**). — **si** . . . **deducerentur** (fut. condition), *if they should be reduced to such an extremity*. — **quamvis fortunam**, *any fortune whatsoever* (**quam-vis**, *what you will*). — **consuēssent**: for the form, see § 128. a; G. 151. 1; H. 235.

**51. CHAP. 32. consuetudine . . . merito**, abl. of cause: § 245; G. 406; H. 416. — **attigisset . . . dedissent** stand for **attigerit** (§ 327. *a*; G. 576; H. 520) . . . **dedideritis** (fut. perf.) of the direct. — **aries**: a long beam with an iron head (like a ram's), suspended from a framework, and swung with great force against a wall, crumbling the strongest masonry (see Fig. 26). — **condicionem, terms**. — **nisi armis traditis**, abl. absolute: i.e. he would make no terms unless they had *first* given up their arms. Notice the time of the participle (cf. **nisi munitis castris**, Chap. 20<sup>2</sup>).

2. in **Nerviis**, in the case of the *Nervii*. — **facturum**: i.e. in case they came to terms. (Dir. disc.: **id quod feci, faciam**.) — **finitumisque imperaturum** explains **facturum**. — **que** in this use is called the explanatory or "epexegetical" "**que**." **finitumis = finitimis**. — **ne quam injuriam inferrent**, to do no wrong to, &c. (**quam = any**, 105. *d*; G. 302; H. 455. 1). — **re nuntiata ad suos**, the message being CARRIED to their people: the idea of motion causes the use of **ad suos**; **suis** (dat.) would refer simply to the utterance of the message, not to its being carried (§ 225. *b*; G. 344. R. 1; H. 384. 3). — **imperarentur**: the subjunc. shows that this subord. clause is a part of the indir. disc. (§ 336; G. 653; H. 524). — **facere** (supply **se** as subj. acc.): we should expect **facturos** [esse]. The present gives the idea of eagerness and promptness (§ 276. *c*; G. 219; H. 467. 5). — **dixerunt**: i.e. the ambassadors.

3. **prope . . . adaequarent** (result clause), almost came up to the very top of the wall and the mound (Cæsar's earthwork, see long note on Chap. 12<sup>2</sup>), filling up the space between them. — **et tamen, but still**. — **ut, as**. — **eo die**: the day is thought of as fixing the time, not as marking its duration; hence the abl. (§ 256; G. 392; H. 429).

CHAP. 33. **sub vesperum, towards evening**. — **ex oppido exire**: for the repetition of **ex**, see § 243. *b*; G. 388; H. 413. N. 3. — **ne quam**: § 105. *d*; G. 302; H. 455. 1. — **ante inito consilio, in accordance with a plan previously agreed upon**. — **quod crederant**: § 321; G. 539; H. 516. I. — **praesidia**: i.e. those stationed in the **castella**. — **aut denique, or at any rate**. — **servaturos** [esse], would keep (guard).

2. **partim . . . partim**, *some of them . . . some of them* (lit. *partly . . . partly*). — **ex cortice**, abl. of material: § 244. *c*; G. 396; H. 415. III. — **viminibus intextis**, abl. absolute. (Possibly, however, **intextis** agrees with **scutis**, and **viminibus** is abl. of material.) — **quæ**: the antecedent is **scutis**. — **ut, as**. — **pellibus** (abl.) **induxerant**, *they had covered with hide* (§ 225. *d*; G. 348; H. 384. II. 2): the commoner construction would be with the dat., **quibus pelles** (acc.) **induxerunt**. — **quâ**, *where*: an abl. or instrumental form, used adverbially; **parte** is not to be supplied.

3. **Celeriter**: note the emphatic position. Cæsar had ordered them to give the signal, in case of any disturbance, and *to do it instantly*. — **eo**, *thither*. — **concursum . . . pugnatum**: impersonal use of passive (§ 146. *c*; G. 199. R. 1; H. 301. 1). — **ita . . . ut**, *they fought as fiercely as brave men ought to have fought*: for the force of the pres. infin. **pugnari** with the perf. **debuit**, see § 288. *a*; H. 537. 1. — **in extrema spe**, *for their last chance* (lit. *in the last hope*). — **iniquo loco**: § 258. *f*; H. 425. 2. — **eos qui**, *men who*. — **qui . . . jacerent**, subj. of characteristic. — **in una virtute**, *in valor alone*. — **cum . . . consisteret**, *at a time when*: a clause of characteristic; used to define the occasion (the *kind* of time), not to fix the date. (See note on Bk. III. Chap. 9, "The Conjunction **cum**," II. *a*. 2.)

4. **ad**, *about*. — **jam . . . nemo**, *no one any longer*. — **sectionem vendidit**, *sold the booty at auction*. — **universam**, *in one lot, in the lump*.

## 52. **relatus est**, *was reported*.

CHAP. 34. **Venetos**, &c.: the name of the Veneti survives in the modern *Vannes*; that of the Redones, in *Rennes*. — **maritumæ civitates**: inhabiting the modern Brittany; they are spoken of at length in Book III.

CHAP. 35. **pacata**, *subdued*. — **pérlata**: notice the force of **per**; the news travelled from tribe to tribe. — **incolerent**: § 342; G. 666; H. 529. II. — **qui . . . pollicerentur**, purpose. — **se . . . daturas**: "not **daturos**; they were representatives sent to report what the *states* promised."

2. **Illyricum**: this province, east of the Adriatic, formed part of Cæsar's government. — **properabat**, *was in a hurry to start*.

3. **Carnūtes**: their country lay between the Seine and the Loire, comprising the modern *Orleans*; their name is preserved in the modern *Chartres*. — **Andes** (whence *Anjou*): near the lower Loire; **Turōnes**: preserved in *Tours*.

4. **ex litteris**, abl. of cause: § 245; G. 406; H. 416. The facts, as reported by Cæsar in his official letter to the Senate, were the ground of the *supplicatio*. — **quindecim dies**, acc. of duration of time: construe with **supplicatio**. — **supplicatio**, a *public thanksgiving*: ten days was the longest time that had ever been granted before, except to Pompey, who was honored with twelve for his victory over Mithridates. But Cæsar's party was now all-powerful at Rome. — **quod**: for **id quod**; see § 200. *v*; G. 616. R. 2; H. 445. 7.

THE LEGIONS. — In the campaign of 57 B.C., Cæsar had eight legions: the six used in the previous year, and the two newly levied (Chap. 2<sup>1</sup>).

## APPENDIX.

THE order of the words is so important for the right understanding of Latin that we append a translation of the first chapter of Book II. with especial reference to the emphasis indicated by the order. The teacher must use his discretion as to how much can profitably be communicated to beginners under his particular method of instruction. Furthermore, as the translation is made expressly to bring out explicitly the force of order, it should not be taken as a model of desirable translation. Such a translation as is here given forces the emphasis on the attention more than is perhaps natural in English. The force is all present in the Latin, but in English it may often be left to be brought out by the context or by some kindred emphasis which the English substitutes. For a like translation of Bk. I. Chap. 1, see A. & G. Latin Grammar, Revised ed., pp. 387-388.

And BEING<sup>1</sup> thus in *Hither*<sup>2</sup> Gaul, as I have shown above, CÆSAR<sup>3</sup> had FREQUENT<sup>4</sup> rumors brought to him,<sup>5</sup> and DESPATCHES<sup>6</sup> also from LABIENUS<sup>7</sup> continued to inform him that ALL<sup>8</sup> the BELGÆ,<sup>9</sup> who constituted a *third part*<sup>10</sup> of [the whole of] Gaul, as I had [previously] stated, were conspiring [for an attack] against the *Roman government*<sup>11</sup> and exchanging hostages. That for THIS

<sup>1</sup> The emphasis on *being* binds this part of the narrative with the situation left at the end of the last Book. "Cæsar went to Hither Gaul, and while he was engaged there."

<sup>2</sup> Opposed to *Farther* Gaul, where the troops were.

<sup>3</sup> The main subject of discourse.

<sup>4</sup> The repetition of the stories is the significant fact, "he kept hearing," but at the same time the rumors are opposed to Labienus' despatches.

<sup>5</sup> An emphasis continued in Latin from *Cæsar*, the main person (see A. & G. § 344. 1), but lost in English.

<sup>6, 7</sup> Opposed to the rumors.

<sup>8, 9</sup> Both words together the subject of discourse, but the adjective most prominent, "*the entire body of the Belgæ.*"

<sup>10</sup> Opposed to the whole, as one might say, "*a full third of the whole.*"

<sup>11</sup> Here not the conspiracy itself, but the aim of it is the most important part of the idea.

CONSPIRACY<sup>12</sup> the reasons were *these*,<sup>13</sup> namely: in the first place, because THEY WERE AFRAID<sup>14</sup> (i.e. in their own minds) that when Gaul was ALL<sup>15</sup> *subdued*,<sup>16</sup> our army would be brought against *them*<sup>17</sup>; and in the second place, because *some*<sup>18</sup> of the *Gauls*<sup>18</sup> (i.e. from outside) were tampering<sup>18</sup> with them. These Gauls were PARTLY those who were disturbed that the ROMAN<sup>19</sup> army should pass the *winter*<sup>20</sup> and *get a*<sup>20</sup> *footing* in Gaul, *just as*<sup>21</sup> they had been unwilling that the GERMANS<sup>22</sup> should *stay any longer*<sup>23</sup> there, and PARTLY those who from [mere] *fickleness*<sup>24</sup> and *unsteadiness*<sup>24</sup> were [always] eager for *new*<sup>25</sup> forms of government; [they were stimulated] by SOME also besides, who, inasmuch as in *Gaul*<sup>26</sup> regal power was regularly usurped by the *more powerful*,<sup>27</sup> and those who had means to *employ soldiers*<sup>28</sup> could not SO EASILY<sup>29</sup> succeed in *such usurpations*<sup>30</sup> under our *imperial control*.<sup>31</sup>

<sup>12</sup> The main subject of discourse, "now *this conspiracy*, the reports said," etc.

<sup>13</sup> The difference between "the reasons why were *these*" and "these were *the reasons why*" is obvious. Cæsar might say either.

<sup>14</sup> A peculiar emphasis not directly carried out. Cicero would very likely have been more rhetorical and have opposed "*fear*" to "*being tampered with.*" But Cæsar changes his point of view in the course of the sentence; and, as if he had said *ipsi* in the first member, opposes to the motives of the Belgæ *themselves*, the Gauls by whom *outside* influence was brought to bear.

<sup>15, 16</sup> The *completion* of the business now in hand is first emphasized, then the business itself.

<sup>17</sup> Cæsar brings out the whole force of the idea by opposing "*them*" to "*Gaul*," which has not before been emphatic, but which is now made so by being contrasted with the Belgians (cf. Chiasmus, A. & G. § 344. *f*).

<sup>18</sup> See note 14.

<sup>19</sup> Opposed to the "Germans."

<sup>20</sup> Opposed to "stay any longer."

<sup>21</sup> The English emphasis here represents the position of the two clauses, relative and antecedent.

<sup>22</sup> See note 19.

<sup>23</sup> See note 20.

<sup>24</sup> Notice that the view of the first party is a rational idea seriously thought out, to which implied state of mind the inconstancy of the second party is opposed.

<sup>25</sup> A natural consequence of their character. For no good reason they got tired of the established order and wanted a *change*.

<sup>26</sup> Opposed to countries in which the Romans were familiar with permanent government.

<sup>27, 28</sup> The two means of attaining regal power.

<sup>29</sup> And consequently wanted to rebel.

<sup>30</sup> The Latin often compresses into an indefinite, and to us unemphatic, word, a whole important idea. The emphasis appears in English when a suitable word is substituted according to our way of saying things.

<sup>31</sup> This control, of course, tended towards establishing order.

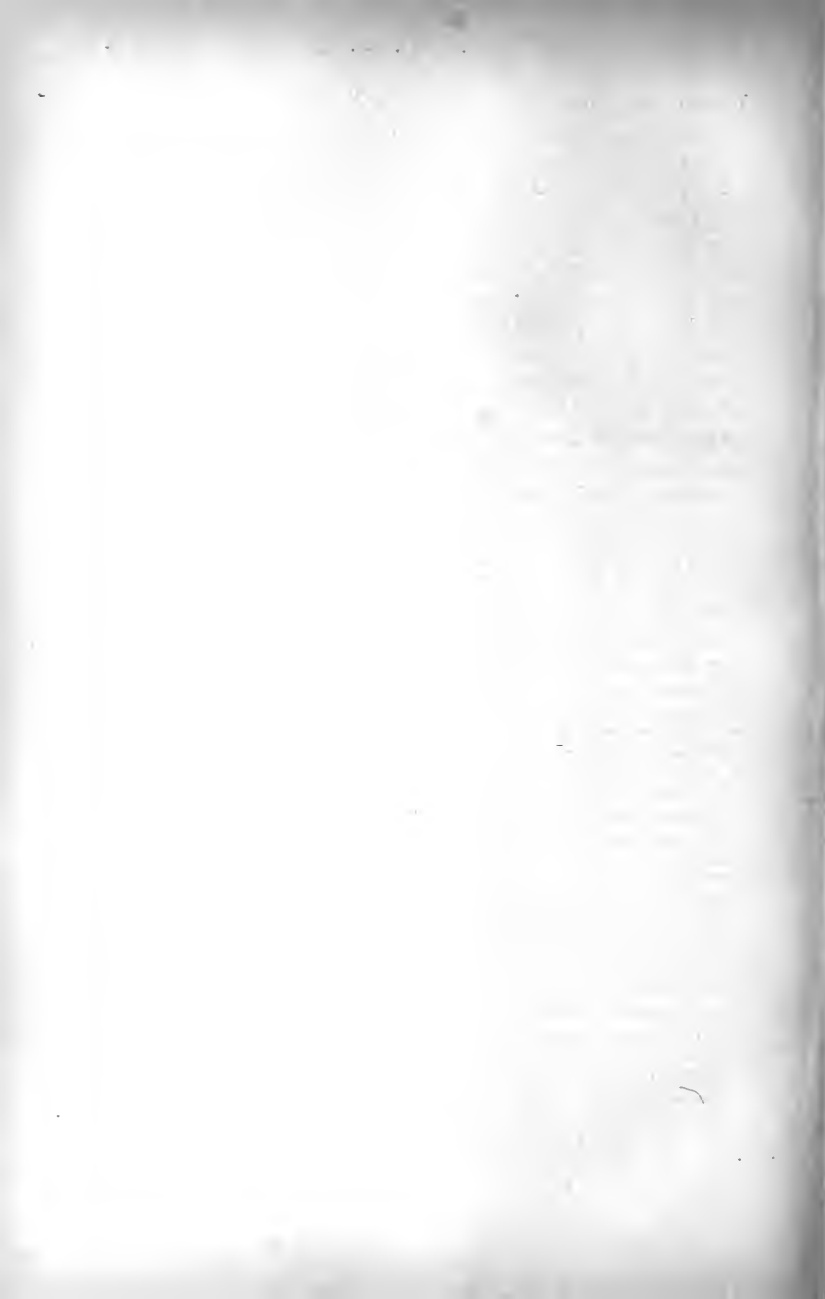



## BOOK THIRD. — B.C. 56.

ALPINE CAMPAIGN. — The higher valleys of the Alps were inhabited by tribes who got a scanty living by working in mines, and often waylaid and plundered expeditions on the march (see Strabo, iv. 6). The two legions sent by Cæsar under Q. Pedius (Bk. II. Chap. 2) had been attacked by these predatory people while passing into the valley of the Rhone above the Lake (*Valais*). Hence this expedition, which was intended to strike terror into the mountain tribes.

**53.** *Nantuatīs* (acc.), &c. These tribes occupied the valley of the Upper Rhone, canton *Valais*, above the Lake of Geneva.

2. *iter per Alpes*: the pass of the *Great St. Bernard*, which reaches the Rhone valley at *Martigny* (the ancient *Octodurus*), at the great bend of the river. This was the principal route across the Alps at this period. Hannibal had crossed by the Little St. Bernard, and the pass by *Mont Genève* was also in use. — *magno cum periculo* [Et. 296] = *but only with great danger*. — *magnis portoriis*, *heavy transit-duties*. — *volebat*: Et. 525.

**54.** 5. *hic*, *ejus*, both referring to *vicus*. — *flumine*, the *Drance*.

CHAP. 2. *certior*: Et. 69. — *montes*: not the higher ranges, but the lower heights directly upon the valley.

2. *id, this*, in appos. with *ut . . . caperent*. — *opprimendae*, *crushing*, the usual meaning of this word. — *neque eam plenissimam*, &c., *and that not entirely full, since two cohorts had been detached*, &c. The twelfth legion had suffered severely in the battle on the Sambre (Bk. II. Chap. 25). In this place *plenissimam* does not refer to the normal number of men in a legion, but merely to the actual strength of this legion, including all detachments. — *singillatim*, *in small parties*.

3. *cum ipsi . . . decurrerent*, *when they should charge down from the hills upon the valley*. The imp. subj. of ind. disc. with *cum* is here equivalent to the fut. ind. of direct discourse. See note on Chap. 9, "The Conjunction *cum*," II. 2. *b*.

4. **accedebat quod** = *and besides (it was added that)*. The subject of **accedebat** is the clause **quod . . . dolebant**, *they were angry that their children were taken from them as hostages*. — **Romanos . . . adjungere**, obj. of **habebant**, and in agreement with **persuasum** (see note on **coactum habebat**, Bk. I. Chap. 15): *they had persuaded themselves that the Romans were attempting, &c.*

THE WINTER CAMP. — The winter camp (*castra hiberna*), in its general arrangement, resembled the ordinary summer camp. There must have been the same fortifications and streets. However, the convenience and comfort of the men were more regarded than when in the field. In place of tents (*tabernacula, pelles*) the winter quarters afforded huts, which gave better protection against wind and weather. The arms were doubtless kept in the huts, and the pack animals in sheds. Then, too, more room could be taken than in the field. In the present case, Galba saved labor by appropriating a part of the Gallic buildings without much ceremony; but he proceeded to lay out the usual fortifications (see **munitiones**, Chap. 3<sup>1</sup>).

CHAP. 3. **perfectae**, referring both to **opus** and **munitiones**, but agreeing with the nearer. — **satis esset provisum**, *sufficient provision had been made*.

**55. consilio**, a council of officers. — **celeriter**: Et. 48.

2. **praeter opinionem** = *unexpectedly*. — **subsidio veniri** = *it was impossible that any one should come to their aid*: **veniri** is impersonal, the subject of **posset** implied in **possent**.

3. **nonnullae sententiae**, *several opinions* (or votes) given by the officers in council.

4. **majori . . . placuit**, *it was determined by the majority*. — **hoc . . . defendere**, *to reserve this course for the extremity, and meanwhile, &c.*

CHAP. 4. **gaesa**, Gallic javelins, entirely of iron.

2. **integris** [Et. 189] **viribus** (abl. abs.), *as long as their strength was unimpaired*. — **repugnare, mittere, occurrere, ferre, superare**, historical infinitives, implying incessant action. — **ut . . . videbatur**, *as (= whenever) any part seemed, &c.*: a relative clause, of which the antecedent is **eo**. — **occurrere**, *ran to meet the danger*. — **alii** = *while others*.

3. **non modo . . . sed ne . . . quidem**, *not only not, but not even, &c.*

CHAP. 5. **cum pugnaretur**, *when the fight had been [and was still] going on* (§ 277. *b*; G. 225; H. 469. II. 2). — **languidioribus nostris** (abl. abs.), *as our men were less active*. — **deficerent**, *begun to be exhausted*. — **vallum . . . complere**; the rampart was made for the most part of earth thrown up in digging the ditch, stakes or palisades being planted above (see note on Bk. I. Chap. 49, "The Camp," 3, 9).

**56. extremum auxilium = the last resource.**

3. **intermitterent**, hort. subj. following **certainiores facit** in the sense of *instructs*. — **tela . . . exciperent**, *gather up the spent weapons*, spending no strength in throwing them back.

CHAP. 6. **cognoscendi facultatem**, *opportunity of finding out*. — **sui colligendi** [Et. 440] = *of collecting their wits*: observe that **sui** is plural in meaning (§ 298. *a*; G. 429. R.; H. 542. I. N.<sup>1</sup>). It is, however, properly the gen. sing. of **suum** (§ 99. *c*; H. p. 71, foot-note 3).

2. **circumventos interficiunt = they surround and kill**. — **ex milibus**, for part. gen. after **parte**.

3. **armis**, abl. of separation. — **exutis**, *stripped*, agreeing with **copiis**: § 225. *d*; G. 348; H. 414. I.

4. **nolebat**: Et. 525. — **alio consilio . . . aliis rebus**, *remembered that he had come with one design, and saw that he had met a different state of things*.

NAVAL CAMPAIGN. — The peninsula of Armorica (*Bretagne*, Brittany, or Little Britain, so called since the emigration from Great Britain to escape the Saxon invasion) has always been the home of the hardiest, most independent, and most strongly characterized of all the Gallic populations. Its scenery is wild and secluded, this character of its coast being clearly given in Cæsar's narrative. Its language remains Celtic to this day. No one of Cæsar's campaigns shows more strikingly his boldness and fertility of resource than this.

CHAP. 7. **pacatam**: Et. 285. — **Germanis**, i.e. Ariovistus. It will be noticed that the geographical order, and not the order of

events, is followed in this summary. Of the Alpine tribes the *Seduni* are mentioned as the most important. — *inita hieme*, in the beginning of winter ("winter being entered on").

2. *mare* following *proximus* with the construction of *prope* (§ 261. a; G. 356. R.<sup>4</sup>; H. 391. 2).

3. *praefectos*, officers of cavalry and auxiliaries.

**57.** CHAP. 8. *hujus civitatis*, i.e. the Veneti, on the southern coast of Brittany, the modern *Morbihan*. — *longe amplissima*, very great indeed. — *consuerunt*, are accustomed (§ 279. d. R.; G. 228. R.<sup>1</sup>; H. 297. I. 2). — *in magno . . . aperto*, in the great and open violence of the sea = on a sea exposed to great and violent storms. — *omnes habent vectigales*, treat all as tributaries, i.e. levy tolls upon.

3. *ut sunt*, &c., as in fact the resolutions of the Gauls are, &c.

4. *quam acceperant*, indic. as a clause of *fact* (§ 336. b; G. 630. R.<sup>1</sup>; H. 524. 2). — *quam perferre*, than to endure, following the comparative contained in *mallent*.

5. *remittat*, subj. expressing a command in ind. disc., depending on the message implied in *legationem mittunt*. The direct discourse would be "*si vis*," &c., "*remitte*."

CHAP. 9. *aberat longius*, was too far off to take command at once in person. — *naves longas*, galleys.

NAVES LONGAE. — The Roman galley was a long, low vessel, armed at the prow with a sharp beam (*rostrum*) shod with bronze for striking and sinking the enemy, and propelled by one or two sails and a multitude of oars. The seamen (*naulae*) attended to the steering and managing of the sails, and were freemen. The rowers (*remiges*) were usually slaves. In the Mediterranean, galleys were commonly provided with two, three, or more tiers of oars, and were accordingly called *biremes*, *triremes*, etc. It seems probable, however, that the fleet Cæsar had built on the Loire consisted of boats with but one bank of oars, and hence were quite low, and decked over only at the bow and stern. The steering apparatus was a couple of broad-bladed oars near the stern, one on each side. The rudder was unknown to the Romans. The fighting men on these vessels of Cæsar were legionaries embarked for the purpose. In fact there was no distinct naval service, as with us. A fleet was simply an army afloat. It

was commanded, as we see also on occasion of the expeditions to Britain, by military officers. On the decks were placed *tormenta* and *turres*, the latter in readiness to raise by ropes and pulleys attached to the mast.

The Gallic ships, it seems, used sails alone, without oars (see Chap. 14<sup>b</sup>).

**Ligere**, the *Loire*, on the banks of which Crassus was wintering. — **institui**, to be organized, i.e. in gangs for the several galleys. — **cum primum**: the first moment when (lit. when first); compare **quam primum** (§ 93. b).

#### THE CONJUNCTION **Cum**.

In the seven books *De Bello Gallico*, Cæsar uses **cum** as a conjunction 283 times.

I. In 62 places it is plainly causal (*as, since*), and in 13, concessive (*although*), and therefore takes the subjunctive (e.g. Bk. I. Chap. 2<sup>1</sup>. 26<sup>2</sup>. See § 326; G. 587-8; H. 515. III. 517).

II. In the remaining 208 places it is as clearly temporal (*when, while, after*).

a. 1. In 160 of these it introduces a clause the *main* use of which is to define the time of a past action, and it is followed by the imperfect or pluperfect subjunctive. With the former tense the clause may denote either a point of time or a period, and the conjunction should be translated *when* or *while* respectively. With the pluperfect the translation may be *when* or *after* (e.g. Bk. II. Chap. 1<sup>1</sup>; Bk. I. Chap. 26<sup>3</sup>. See § 325; G. 586; H. 521. II. 2). The temporal clause usually expresses an event that actually happened; but the subjunctive shows that the writer's *main* idea in using the clause is to indicate by it the *time* of the event expressed by the principal statement.

2. Occasionally the clause with **cum** and the subjunctive is used to characterize a period of time, some form of **tempus** being expressed or understood (*at a time when, &c.*). This construction gives us simply a subjunctive of characteristic (e.g. Bk. I. Chap. 16. See § 320; G. 582. R. I, 634; H. 521. II. 2. 1); this was without doubt the original meaning of all subjunctives with **cum**.

b. As the story of the Gallic war is purely narrative, containing few direct quotations, and those the briefest, we naturally find no instances of the use of **cum** with the future or future perfect indicative. In 13 passages, however, it occurs in the indirect discourse with a subjunctive that takes the place of one or the other of these tenses. In such sentences the

temporal clause is equivalent to a protasis (e.g. Bk. I. Chap. 39<sup>5</sup>. See § 325. *c*; G. 584; H. 507. 3).

*c*. In 33 passages **cum** takes the indicative with tenses referring to present or past time, and in 2 others, Bk. II. Chap. 4, Bk. VI. Chap. 25, the subjunctive in indirect discourse equivalent to the historical perfect indicative. The mood shows that the writer's main idea in using the temporal clause is to emphasize the *reality* of the event expressed by it, and that the temporal relation is of secondary importance. We distinguish several varieties of usage.

1. In 21 sentences the verb in the temporal clause denotes a repeated action. **Cum** here is equivalent to **quotiescumque** (*whenever, as often as*), and the clause is really the protasis of a *general* conditional sentence (e.g. Bk. I. 1<sup>3</sup>. IV. 33<sup>1</sup>. III. 14<sup>5</sup>. See §§ 322, 309. *c*; G. 568-9, 585; H. 471. 3 and 5; Madvig, 335, Obs. I. 359).

2. In 8 sentences **cum** is used as the correlative of **tum**, in the sense of *both . . . and*. The indicative of a verb expressed or implied is used in both clauses, unless in indirect discourse (e.g. Bk. V. Chap. 4<sup>3</sup>. See § 326. *b*; G. 589; H. 521. N.<sup>1</sup>).

3. In 3 places (Bk. VI. Chap. 7<sup>1</sup> and Chap. 8<sup>1</sup>, Bk. VII. Chap. 26<sup>3</sup>) the clause with **cum** is really the main proposition (see Madvig, 358. Obs. 1; § 325. *b*; G. 581. R.); this is the so-called *cum inversum*, by which the clause of time with the indicative (as in *c* above) is made the principal proposition in form. And in one other place (Bk. I. Chap. 40<sup>4</sup>) it is really a co-ordinate clause, **cum** being equivalent to **et tum**.

4. In the remaining 2 passages (Bk. III. Chap. 9, Bk. VI. Chap. 12) the indicative is used with **cum** merely to emphasize the reality of a simple past action.

2. **in se admisissent**, *had taken on themselves*: **admitto** alone is the ordinary phrase for *commit*. — **legatos . . . coniectos** (the specific act), in appos. with **facinus**.

**58.** 3. **pedestria itinera, &c.**, *approaches by land were cut off*. — **inscientiam**, i.e. the Romans' lack of acquaintance. — **neque . . . confidebant**, *and they trusted that our armies could not, &c.*

4. **ut . . . acciderent** (concessive, § 266. *c*; G. 610; H. 515. III.), *granting that everything should turn out contrary to their expectation*. — **plurimum posse**, *were strongest*. — **facultatem**, *supply*. — **longe aliam . . . atque**, *very different . . . from*. — **concluso**, *enclosed* (like the Mediterranean).

5. **Osismos**, &c., the coast tribes as far as Flanders. The name *Lexovii* remains in *Lisieux*; *Namnetes* in *Nantes*; *Diablintres* in *Fabliens*.

CHAP. 10. *injuriae retentorum equitum*, the wrong done by detaining the knights (§ 292. a; G. 667. R.<sup>2</sup>; H. 549. 5. N.<sup>2</sup>). — *rebellio*, renewal of hostilities (not rebellion). — *ne . . . arbitrantur*: a new rising was threatened by the Belgians, while the maritime tribes, it is said, were already fearful of an attempt upon

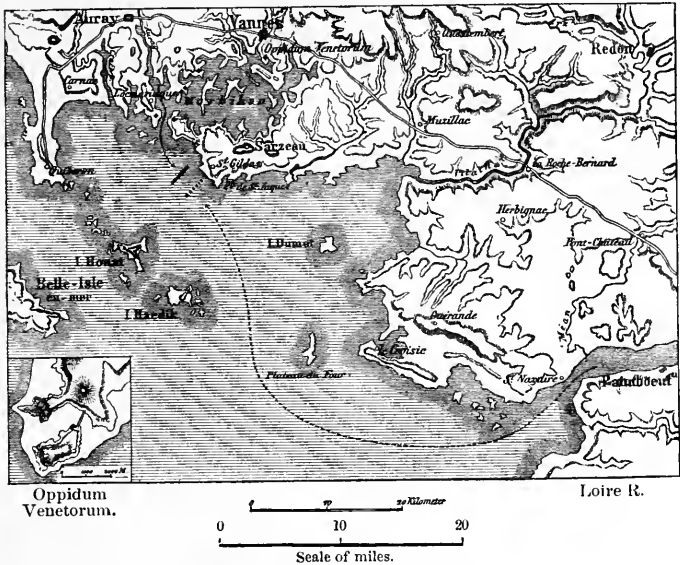

Plan VII. Campaign against the Veneti. Bk. III. Chap. 7-16.

The dotted line shows the course of the two fleets from the Loire and the Auray respectively.

Britain. (Observe that this clause is under the same construction as the nominatives *injuriae*, *defectio*, &c.)

2. *excitari*: the present infin. here corresponds to the imperfect of *description*, *excitabantur*: while *odisse* answers to *oderunt* taken as a present, *all men naturally hate*. — *homines*: Et. 157.

CHAP. 11. *mandat adeat, gives it in charge (manui dare) to advance upon* (§ 331. f. R.; G. 547. R.<sup>3</sup>; H. 499. 2).

**59. arcessiti** [esse] *dicebantur, were reported to have been invited.*

2. **Aquitaniam**, in S. W. Gaul (see Bk. I. Chap. 1<sup>5</sup>). The people were of different race and language from the other Gauls, and took little interest in their affairs, not even joining in the great revolt of Book VII. But Cæsar may not have known this (Moberly). — **nationes**: Et. 112.

3. **Unellos, &c.**, in Normandy.

4. **Decimum Brutum**, afterwards one of the conspirators against Cæsar, with the more celebrated Marcus Brutus. — **Pictonibus, Santonis**, south of the Loire (*Poitou* and *Saintonge*).

CHAP. 12. *ejus modi . . . ut, of such sort that.* — *cum . . . incitavisset = at high tide.* — **aestus, tide**: properly the surging movement of boiling water; hence applied both to extreme heat and to ocean-tides. — **bis**, apparently an error of most Mss. Some editors read xxiv instead of xii; others refer it to the general ignorance or carelessness of ancient writers. — **minuente, at the ebb**: intransitive, as if from the passive form used as a reflexive, as in case of deponents.

2. **utraque re, in either case.** — **superati**, agreeing with the subj. of **cooperant.** — **his** (aggere ac molibus) . . . **adaequatis, when these were brought level with the walls.** — **defendebant**: Et. 257.

General von Göler explains the Roman works as follows: A dike was extended along each side of the isthmus in the direction of the town. While these were building, of course with each rise of the tide the space within would be overflowed. When the dikes were nearly completed, the Romans waited until the ebb had carried off the water, and then rapidly pushed their works to completion before the next turn of the tide. Thus the sea was shut out and the isthmus left dry. Meanwhile the dikes themselves, being raised to the height of the walls, served the purpose each of an *agger* for approach to the town.

3. **haec faciebant, this they continued to do.** — **eo facilius . . . quod, the more easily, that, &c.** — **vasto mari, &c.** (ablatives abso-



lute, denoting cause) ; in each of these points the ocean is contrasted with the sheltered and tideless waters of the Mediterranean.

CHAP. 13. *ipsorum, their own.* — *modum* : Et. 238. — *aliquanto* (abl. of degree of difference) *planiores, considerably more flat-bottomed.* — *navium*, gen. depending on *carinae* understood. — *quo . . . possent, that they might more easily stand the shallows and the ebb-tide* ; § 317. b ; G. 545. 2 ; H. 497. 2.

2. *admodum erectae, very high.* — *atque item puppes, and the sterns too* : *adcommodatae (being adapted* : Et. 338) standing as predicate. — *robore, oak timber.*

60. *contumeliam, buffeting.* — *transtra, &c., the cross-benches* (for the rowers) *of timbers a foot thick, fastened with iron bolts the thickness of a [man's] thumb.*

3. *pelles, hides* ; *alutae, leather.* — *tanta onera navium, ships of so great weight.* — *non satis commode, not very well* : Cæsar does not like to say that anything is impossible.

4. *nostrae classi* (dat. of possession), &c., *the encounter of our fleet with, &c.* — *una, only.* — *praestaret, had the advantage* (i.e. our fleet). — *pro loci natura, considering the nature of the place.*

6. *accedebat ut = there was this additional advantage, followed by ferrent, consistenterent, and timerent.* — *se vento dedissent, ran before the wind.* The phrase is nautical : hence the noun is repeated. The clause *cum . . . dedissent* is parenthetical. — *consisterent, came to anchor* ; *ab aestu relictae, &c., if left by the tide, had nothing to fear, &c.* — *casus, the chance of all these things.*

CHAP. 14. *neque . . . posse, that the enemy's retreat could not be prevented by capturing their towns.*

2. *paratissimae, fully equipped* ; *ornatissimae, thoroughly furnished.* The battle was fought in the bay of *Quiberon*, off the heights of *St. Gildas*, on which Cæsar was encamped. The fleet of *Crassus* issued from the *Loire* and took a northwesterly course. Meanwhile the fleet of the *Veneti* came out of the *Auray* estuary, and passing through the *Morbihan* entrance to the bay, encountered the Romans directly opposite Cæsar's camp. The dotted line in *Plan VII.* shows the course of the two fleets. — *neque satis Bruto . . . constabat, and it was not clear to Brutus (agerent and*

insisterent refer to Brutus and his officers). — **tribunis militum centurionibusque**: notice the military officers in command of the fleet.

3. **excitatis**, *lifted up*. — **ex barbaris navibus**, *on the part of the enemy's ships* (compare Bk. I. Chap. 2<sup>d</sup>, note).

61. 4. **magno usui**, *of great service*, in fact turning disaster to victory: but Cæsar will not use words that hint a possible defeat. — **muralium falcium**, *wall-hooks*, long poles with sickle-shaped hooks attached (like those used by "hook-and-ladder" companies) used to pull down walls (see Fig. 26): it limits **formae** (understood), dat. after **absimili**.

5. **cum**: See note on Chap. 9, "The Conjunction **Cum**," II. c. 1. — **prærumpebantur**, *they [the halyards] were torn away*. (Observe the position of **funes** in the clause with **cum**.)

7. **paulo fortius factum**, one of Cæsar's mild expressions for *an act of remarkable daring*.

CHAP. 15. **cum**: see note on Chap. 14<sup>b</sup>. — **singulas**, &c., *two or three ships about each one* (of the enemy's). — **contendebant**, *made repeated efforts*: compare with **contenderunt** below, describing a single act.

2. **expugnatis . . . navibus**, *when many of their ships had been captured*.

3. **conversis . . . navibus**, i.e. steered so as to run before the wind. — **malacia**, *calm* (a Greek word).

The prevailing winds at present towards the end of summer in this quarter are from the east or north-east, — the precise winds needed for the two fleets to have met as indicated above. Further, when these winds have blown during the morning, it usually falls calm at noon. This is just what happened on the day of the battle. The calm was probably just after midday.

4. **pervenerint**, *came to land*: **pervenirent** would be equally correct, and is found in some copies; but the perfect conveys more distinctly the *act of landing*. — **hora quarta**, about 10 A.M.

CHAP. 16. **cum . . . tum**, *while . . . at the same time*. The phrase is similar to a very frequent Greek construction ( $\mu\acute{\epsilon}\nu . . . \delta\acute{\epsilon}$ ).

— **convenerant, coegerant**, i.e. for this war. — **quod ubique**, *all there were anywhere*, followed by the partitive gen. **navium**.

2. **quo**, i.e. [any refuge] *whither*; **quem ad modum** (often written as one word), *how*.

**62.** 3. **eo . . . quo**, *the more severe, &c., in order that*. — **vindicandum** (impersonal), *punishment should be inflicted*. — **omni senatu necato**, an instance of Cæsar's *clementia*. — **sub corona vendidit**, *sold [as slaves] at public auction*: lit. *under the wreath*, since the captives "were crowned like an animal for sacrifice."

"This can hardly mean that Cæsar sold the whole nation by auction. The mention of the Senate makes it probable that the inhabitants of the capital Dariorigum [*Vannes*] are meant. Even so the rigor is terrible; and the more so, as regards the Senate, from the grim alternative which the next chapter suggests [of being massacred by their own people, Chap. 17<sup>2</sup>] as the only one open to these unfortunate rulers" (Moberly).

"He has not said, as he does on another occasion (Bk. II. Chap. 33), how many were sold, but we may infer that he depopulated the country of the Veneti at least; and it appears from a later book (Bk. VII. Chap. 75) that all the Armoric states must have been greatly reduced by this unfortunate war. The only naval power in Gallia that could be formidable to the Romans was totally destroyed, and neither the Veneti nor their allies gave the proconsul any more trouble" (Long).

**CHAP. 17. Unellorum**, along the Channel coast of Normandy. Another form of the name is *Venelli*. — **magnas copias**, *considerable forces* (not supplies, as these fell short, see Chap. 18<sup>4</sup>), most likely meaning here irregular troops (*perditorum hominum*, see next section) as opposed to **exercitum**.

2. **his paucis diebus**, i.e. about the same time. — **perditorum**, *desperate*: it was now the third year of constant war in Gaul.

3. **carperetur**, *was carped at*, his reputation "picked to pieces."

4. **eo absente**, i.e. Cæsar. A *legatus* regularly had no *imperium*, or independent command, but served under that of his superior. — **opportunitate**, *a favorable chance* (**opportunus**).

**CHAP. 18. edocet**, *instructs*.

2. **pro perfuga**, *in the character of a deserter*. — **neque longius esse quin** = *not later than*, i.e. *the time was not farther off*.

**63.** 4. *superiorum dierum*, on the previous days. — *confirmatio*, positive assertion. — *parum diligenter*, i.e. (in Cæsar's style) with too little diligence. — *spes . . . belli* (subjective genitive denoting the source) = *hope founded on*, &c. — *fere . . . credunt* = *most men are glad to believe*, &c.

5. *non prius, . . . quam*, not . . . until.

6. *ut . . . victoria* (abl. abs.) = *as if victory were already assured*. — *sarmentis*, sprouts, or young growth; *virgultis*, brushwood.

CHAP. 19. *paulatim adclivis*, gently rising. — *magno cursu*, on a full run. — *que*, and (consequently).

4. *quos*: the antecedent is *eorum*. — *reliquos paucos*, few of the remainder (§ 216. e; G. 368. R.<sup>2</sup>; H. 440. 2. N.<sup>2</sup>). — *ac* = but.

SOUTHERN GAUL.—The campaign in Aquitania was made merely for strategic reasons, was not provoked by any attack or threat of one, and appears to have been quite unnecessary (see note, Chap. 11<sup>2</sup>) as well as difficult and dangerous. The Aquitani were not closely allied with the Gauls, took no share in their wars, and were at a secure distance. They had no strong military league or combination, but consisted of small isolated clans, and were besides of more industrial habit, being good miners and engineers. As a mere narrative, however, this is an interesting episode of the war.

**64.** CHAP. 20. *ex tertia parte* (an idiomatic phrase) = *as a third part*, a greatly exaggerated reckoning. Many of Cæsar's geographical statements (e.g. the account of Britain, Bk. V. Chap. 13) are extremely ignorant or careless. — *armis*: Et. 333.

*Praeconinus*, *Mallius*: these defeats were 20 years before (B.C. 78), when the Aquitani united with the Marian leader Sertorius, who held Spain for six years against Rome.

2. *Tolosa et Narbone* (early editions add *Carcassone*): Tolosa was an old Gallic town; Narbo, a Roman colony established by the policy of Caius Gracchus, B.C. 118. It became the capital of the Roman province, to which it gave its name.—*Sontiatum*, south of the Garonne, S.E. of the modern Bordeaux: the name remains in the modern *Sôs*.

3. *ostenderunt*, showed.

CHAP. 21. *diu*: Et. 224. — *superioribus victoriis*, i.e. those just related. — *sine imperatore adulescentulo duce*: an *impera-*

*tor* is the chief commander of an army, holding the *imperium*, or power of military command conferred on him by regular formalities; *dux* is a general designation for any person holding a command, and might be given to a subordinate officer, like Crassus, who acted as an agent and under the *imperium* of his superiors. — *perspici*: the subj. is the indirect question *quid . . . possent*. — *vertēre*, histor. infin. The perfect form in *ēre* is very rare in early prose.

2. *vineas turresque egit*: see note on Bk. II. Chap. 11, "The Siege."

3. *cuniculis*, *mines*, so called from their likeness to rabbits' burrows. The mine was intended to run under the Roman *agger*. The roof was carefully propped up with wooden posts, and these being finally set on fire, when they were burned through the entire mass of Roman works would fall into the pit. — *aerariae secturaeque* (hendiadys: see A. & G. p. 298; G. 695; H. 636. III. 2), *copper mines*. [The † indicates a corrupt or doubtful reading. Some editions omit the *-que*, and others have *structurae*, *works*.] — *diligentiā*, *through the watchfulness*. The Romans doubtless met the attack with countermines. — *faciunt*, *they do* [it].

**65. CHAP. 22. soldurios**, *paid retainers* ("soldiers"), from the root *SOLD*. It is related that these *soldurii* "were dressed in royal garments like their chief."

2. *condicio*: the same condition was found among the Germans (Bk. VI. Chap. 23), and was the foundation of feudal vassalage. — *mortem*: Et. 393.

3. *cum his* (repeated from *cum devotis*), *with these* (I say).

CHAP. 23. *Vocatium*, &c., further west. — *quibus*, *within which*. — *quoque versum*, *in every direction* (*quoque*, the adverb of *place* formed from the distributive *quisque*; *versum*, the adverb of *direction* usually connected with prepositions, as *ad . . . versum*). It is often written *quoquoversum*.

2. *Hispaniae*: these Iberian populations were allied to the Aquitani (Bk. I. Chap. 15). Spain had been subject to Rome for more than 150 years, but was always rather mutinous, and had made several attempts at independence, especially under Sertorius (see note, Chap. 20<sup>1</sup>). It was also the last stronghold of Pom-

pey's party in the civil war, till finally subdued at Munda, B.C. 45. — *auctoritate, prestige.*

3. *omnes annos*, i.e. B.C. 78–72. — *consuetudine pop. Rom.*: a custom which they had learned in the service with Sertorius. — *loca capere*, to occupy positions, &c., i.e. make systematic preparations for war. — *instituunt*, begin.

4. *suas . . . augeri*, &c. These infinitive clauses are in apposition with *quod*. — *diduci*, be scattered in various directions. — *minus commode*, less conveniently.

**66. CHAP. 24. duplici**, i.e. *two cohorts in depth*. His numbers were too few to allow greater depth. — *auxiliis*: Et. 138. — *in mediam aciem*, to the centre of his line, where they would be kept in hand by his legionaries (see Chap. 25<sup>1</sup>). — *exspectabat*, waited [to see] *what*, &c.

2. *obsessis viis . . . potiri*, in English, to block the roads, cut off supplies, and win the victory without a wound. — *sese recipere*, to withdraw from Aquitania. — *in agmine*, on the march. — *infirmiore animo* (abl. of quality) = *dispirited*, an adjective phrase in the same construction with *impeditos* (§ 179; G. 402; H. 419. II.). — *adoriri cogitabant*, had in mind to attack. — *productis copiis*, concessive (= *although*, &c.).

3. *sua*, their own. — *opinionem timoris*, the notion [they had given] of their own cowardice. — *expectari . . . iretur*, depending on some word of *saying* implied in *voces*. — *ad hostium castra*: this is the only instance in the Commentaries of an attack by Romans on a fortified Gallic camp. — *omnibus cupientibus* = to the eager desire of them all.

CHAP. 25. *opinionem pugnantium*, i.e. an impression as if actually engaged.

2. *ab decumana porta*, i.e. in the rear, where this gate was situated (see note on Bk. I. Chap. 49, "The Camp"): the Gauls appear to have adopted the Roman mode of constructing camps.

CHAP. 26. 2. *intritæ, unworn*. [Observe that while in the compound *verb* the preposition *in* has an intensive force (*intero, to crumble*), in the compound adjective it has a negative force. Many words have thus two exactly opposite meanings: as *infractus*, (participle) *broken up*, (adjective) *unbroken*.]

**67. prius quam**: this phrase is often used with the indicative to show that one actual fact precedes another, just as succession is denoted by *post quam*. Here the subjunctive subordinates the temporal clause to the main idea, just as with *cum* (§§ 325, 327; G. 579; H. 520).

5. **apertissimis campis**, i.e. the broad, treeless plains which abound in this part of the country. — **consectatus** (intensive from **sequor**), *overtaking in hot chase*. — **Cantabris**, a very hardy people of the western Pyrenees. — **multa nocte**, *late at night* (abl. of time).

CHAP. 27. **dedit**: Et. 225. — **Tarbelli**, &c.: some of the names will be recognized in the modern *Tarbes, Bigorre, Garoune*. — **ultima**, *remotest*.

CHAP. 28. **exacta**: Et. 104. — **omni pacata**, *while all the rest of Gaul was subdued*. — **Morini**, &c., on the islands and low coastlands of Flanders and further north. The Celtic MOR signifies *sea*. — **alia ac**, *different from*.

2. **continentes**, *continuous* = far-stretching.

4. **longius**, *too far* (farther than was safe).

**68. CHAP. 29. deinceps**, i.e. in the days next following. — **caedere**: Et. 244. — **conversam**, *fronting*, i.e. with the boughs turned towards the enemy. — **pro vallo**, *as a palisade*.

2. **tenerentur**, *were just getting within reach*. — **ejusmodi uti . . . intermitteretur**, *such that the work was constantly interrupted (broken off would have been intermissum sit)*. — **sub pellibus**: the tents were of leather.

3. **Aulercis**, &c., along the Seine, near *Evreux* and *Lisieux*. — **proxime**, *last*.

THE LEGIONS. — In the campaign of the year 56 B.C., Cæsar had the same eight legions as in the year before. During the operations against the Veneti, the twelfth legion was with Galba, among the Allobroges (Chap. 6<sup>4</sup>); Sabinus had three legions in Normandy (Chap. 11<sup>3</sup>); Crassus had twelve legionary cohorts (not comprising any one entire legion, but being detailed from different legions) in Aquitania (Chap. 11<sup>2</sup>); while the rest of the army, twenty-eight cohorts (i.e. four legions, less the twelve cohorts detached under Sabinus), were engaged with Cæsar.

## BOOK FOURTH. — B.C. 55.

PASSAGE OF THE RHINE. — The year B.C. 55 appears to have been marked by a general movement in the migration of the German tribes. An advance, consisting of the two populations Usipetes and Tencteri, crowded forward by the more powerful Suevi, crossed the lower Rhine into northern Gaul. Cæsar assumed the defence of the country he had just conquered, drove them back across the Rhine, followed them up by an expedition into their own territories, and fully established the supremacy of the Roman arms. Another brief campaign in Germany two years later confirmed this success, and the Rhine became the military frontier, recognized for many centuries, between the Roman empire and the barbarian world. In the common opinion of France it is to this day the natural boundary, established, as it were, in perpetuity by the arms of Julius Cæsar.

## PAGE

**69. Pompeio, Crasso** (the year 55 B.C.): the coalition between Cæsar, Pompey and Crassus, sometimes called the First Triumvirate, had been formed five years before. In carrying out the scheme, Cæsar held the government of Gaul, while the others took into their own hands this year the whole control of affairs at home (see Introd., "Life of Cæsar"). — **Usipetes, Tencteri**, from beyond the Rhine, a little below Cologne.

2. **Suevis**: this people (the modern *Swabians*) occupied the greater part of central Germany, and was made up of several independent tribes. The name is held to mean *wanderers*. — **premebantur**, *had been crowded* (§ 277. b; G. 225; H. 469. II. 2).

3. **centum pagos** (see Bk. I. Chap. 12): there is probably some confusion here with the ancient German institution of the *Hundred*, a division of the population giving its name to a district of territory. Each *hundred* seems to have sent 1000 men (**singula milia**) to the army. The term early lost its numerical value, and became a mere local designation. — **manserunt**: Et. 358.

4. **alunt**: Et. 426. — **anno post**, *the year after*. — **in vicem** (**invicem**), *in turn*. — **ratio**, *theoretical knowledge*, i.e. *theory*; **usus**, *knowledge derived from experience*, i.e. *practice*.



**70.** 5. **sed**: i.e. they attended to agriculture systematically, *but*, &c. — **privati . . . agri**, i.e. the land was held in tribal communities, — a state of things almost universal among primitive nations. (But see Introduction, near the end.) — **longius anno**: i.e. the community had no fixed possessions, but was transferred yearly from one tract to another, its place being taken by another community. As is shown in Bk. VI. Chap. 22, the community was composed of persons kindred by birth. The annual shifting of occupancy would prevent at once forming local attachments, building up large properties, and too rapidly exhausting the soil.

6. **frumento**, &c.: they were still in a half-nomadic state, though with some little advance in agriculture (compare Bk. VI. Chap. 22, and Tac. Ger. 26). — **maximam partem** (adv. acc.), *for the most part*. — **quom** (some copies read **quod**) . . . **faciant**; this clause is a parenthesis: *since, having been trained from childhood to no service or discipline, they do nothing whatever against their will*, — a lively contrast of barbarous manners with the severity of Roman family discipline. — **alit**, the subj. is **quae res**. — **homines** (pred.) **efficit**, *makes [them] men*, &c.

7. **eam**, correl. with **ut**. — **locis** (abl. abs., concessive) **frigidissimis** = *even in their extreme climate*. — **haberent**, *have*; **laverentur**, *bathe* (imperf. by sequence of tenses following **adduxerunt**: § 287. a; G. 511. R.<sup>2</sup>; H. 495. 1).

CHAP. 2. **eo, ut . . . habeant**, *so (on this account) that they may have [some one] to whom*, &c. — **quam quo . . . desiderent**, *than that they want*, &c. (For the use of **quo** with the implied negative, see § 341. R.; G. 541. R.<sup>1</sup>; H. 516. 2.)

2. **impenso pretio**, *at high cost*. — **importatis non utuntur** = *do not import for use* (lit. *do not use imported*). — **deformia**, *ill-shaped*. — **summi laboris**, [*capable*] *of great labor* (gen. of quality).

3. **eodem vestigio**, *on the same spot* (footprint). — **cum usus est**, *when there is need*. See note on Book III. Chap. 9, "The Conjunction **cum**," II. c. 1. — **ephippiis** (a Greek word), *housings, or horse blankets* (see Fig. 6). There is no evidence of the use of actual *saddles* until the fourth century A.D.

4. **quamvis pauci**, *however few*. — **importari**: Et. 313.

CHAP. 3. **publice**, i.e. to them as a community. — **a suis finibus**, on (back from) their boundaries. — **una . . . Suevis**, extending from [the territory of] the Suevi in one direction. — **agri**, the region (nom. pl.).

**71.** 2. **partem**: Et. 313. — **Ubi**, along the Rhine, opposite Cologne. — **captus**, capacity, hence character. — **paulo . . . humaniores** (omit the words in brackets), somewhat more civilized than the others of that race (Germans).

3. **gravitatem**, importance, referring to the warlike character and extensive resources of the people; while **amplitudinem** refers to their great numbers. — **humiliores** (pred.), sc. so as to be.

CHAP. 4. **in eadem causa**, in the same case. — **ad extremum**, at length.

2. **quas partes**: North Brabant, with the north bank of the Rhine. — **ad utramque ripam**, along both banks.

3. **vi contendere** = to force a passage. — **simulaverunt**: Et. 377.

4. **priusquam . . . fieret**, § 327; G. 579; H. 529. — **eorum copiis**, on their supplies (cattle and grain).

CHAP. 5. **infirmi** **infirmi** **infirmi**, weakness of purpose = fickleness. — **mobiles**: Et. 379. — **nihil . . . committendum**, no confidence should be placed in them. Observe that **committendum** (esse) is impersonal, while **nihil** is an adverbial accusative.

**72.** 2. **est . . . consuetudinis**, it is [a point] of Gallic custom (§ 214. d; G. 365. R.<sup>1</sup>; H. 401). — **vulgus circumsciscitat . . . cogant**, a crowd surrounds the traders, and compel, &c. With the former verb, the crowd is taken as a whole; with the second (in the plural), the inquisitive questioners are thought of.

3. **rebus atque auditionibus**, facts and hearsays. — **in vestigio**, on the spot, i.e. presently (*sur-le-champ*). — **incertis**: Et. 69. — **serviant** = are slaves to. — **plerique**, the travellers; **eorum**, the questioners.

CHAP. 6. **graviori bello**, too serious a war (i.e. unmanageable). — **maturius**, earlier in the season. — **ad exercitum**: the army was now in Normandy (Bk. III. Chap. 29).

2. **uti . . . discederent**, to withdraw from the Rhine further into Gaul. The Belgæ, it will be remembered, claimed kindred with the Germans, and were no doubt ready to retaliate their bloody defeat on the Romans. — **postulassent**, §§ 281, 316, 336; G. 236, 510; H. 525. 2. — **fore parata**, should be made ready (the regular fut. infin. passive, depending on some such word as **promiserunt**, implied in **invitatos**).

3. **Eburonum**, &c.: German tribes (see Bk. II. Chap. 9). — **clientes**: Et. 58.

4. **quæ cognoverat**, the facts he had learned (the subj. **cognovisset** would make it an indir. question; and **ea** would then be out of place, as **quæ** would be interrogative. Again, the subjunctive of *characteristic* is not used, as the facts to which **ea** refers have just been mentioned, in sections 2 and 3). — **permulsis**, calmed from their terror (lit. *soothed by stroking*, like a nervous horse).

CHAP. 7. **equitibus delectis**: the quota of cavalry was required from each of the allied states.

2. **a quibus** refers to **locis**. — **priores**, first, or, as *aggressors* (compare the language of Ariovistus, Bk. I. Chap. 36). — **neque recusare quin**, they do not decline. — **quicumque**: the antecedent is **eis** (dat.) implied with **resistere**. — **neque deprecari**, and ask no quarter (lit. *and not beg off*).

3. **haec tamen dicere**, this however they did say [said they]. — **iis**, to the Romans. — **adtribuunt**, subj. in ind. disc. for imperative of the direct. — **eos**, sc. **agros**. — **concedere**, yield, as inferior.

**73.** CHAP. 8. **quæ visum est**, as it seemed good (see Bk. I. Chap. 14. 43). — **verum**, reasonable.

2. **injuria**, injustice. — **Ubiorum**, see Chap. 3<sup>2</sup>. — **quorum sint**, &c., whose envoys (he informs them) are now with him to complain, &c.

CHAP. 9. **post diem tertium** (= **tertio die**), i.e. *the next day but one*. (The first and last day are usually counted in the Roman reckoning: so in French *en huit jours* = *in a week*.) — **id**, the two days' delay (**ne . . . moveret**).

2. **trans**, i.e. westwardly. — **expectari**, translate as active, *they were waiting for*.

CHAP. 10. **profluit**: Et. 345. — **Vosego**, the *Vosges*: in fact, "from the plateau of Langres, the cradle of French rivers." — **parte . . . recepta**: the Rhine branches in these low, marshy regions, one branch (**Vacalus**, the modern *Waal*), uniting with the Meuse near *Bois-le-duc* (see note, Chap. 15).

2. **oritur**: Et. 414. — **Nantuatum**: compare Bk. III. Chap. 1, where they are placed upon the Rhone, just above Lake Geneva; this was perhaps a branch, or kindred tribe. This list of names is incomplete. — **citatus**, *with rapid course*. — **feris . . . nationibus**: see the introduction to Motley's "Dutch Republic." — **capitibus**, *mouths* (usually *sources*).

CHAP. 11. **ut erat constitutum**, *as had been arranged* (the return of the envoys). Either this is a careless expression, or Cæsar's consent is omitted in Chap. 9. It is there stated merely that *they said* they would return.

74. 2. **eos** (anteced. to **qui**), *the cavalry who*, &c. — **potestatem faceret**, *would give authority*. — **condicione . . . usuros**, *would keep the terms offered by Cæsar*.

3. **eodem illo pertinere**, *tended the same way* (to the same point) (see Chap. 9), i.e. to gain time till the German cavalry should arrive. — **aquationis causa**: a small stream (the *Niers*) lay between him and the German encampment.

CHAP. 12. **ubi primum . . . conspexerunt**, *as soon as they came in sight*. — **amplius octingentos**, *more than 800* (§ 247. c; G. 311. R.<sup>4</sup>; H. 417. 1. N.<sup>2</sup>). Tacitus (*Germ.* 32) says that this tribe was distinguished for cavalry. — **perturbaverunt**, *threw into disorder*.

2. **resistentibus**, sc. **nostris**. — **subfossis**, *stabbed in the belly*. — **ita perterritos**, *so panic-stricken*.

3. **regnum obtinuerat**, *had held supreme power*. — **intercluso**: Et. 56.

75. CHAP. 13. **neque jam**, *no longer*: knowing how little his own cavalry (of Gauls) were to be trusted, and that the arrival of

the main body of the Germans would put them at once to flight, Cæsar resolved to attack at the first opportunity, right or wrong.—*ab iis qui, from men who, &c.*—*insidias*: Et. 234.

2. *quantum auctoritatis, how great prestige the enemy had gained by one battle.*—*quibus, i.e. the enemy.*

3. *quaestore, see Bk. I. Chap. 52<sup>1</sup>.*—*res, in apposition with quod . . . venerunt.*—*māne*: Et. 386.—*eadem perfidia*: their perfidy Cæsar takes for granted, as the best apology for his own; but the presence of the chiefs and old men looks more as if they came (as they said) to offer amends for the attack of the day before.

4. *sui purgandi*: § 298. *a*; G. 429. R.<sup>1</sup>; H. 542. I. N.—*contra atque, contrary to what.*—*si quid . . . de induitiis = whatever (if anything) they could in the way of truce (de with the abl. is nearly the same as the part. gen.).*—*fallendo, i.e. by another trick.*

5. *quos, illos, both refer to the same subject.*—*quos oblatos gavisus, delighted that they were put in his power.* By detaining their chief men, he would at once perplex and disable them.—*subsequi, to follow in the rear*; he could not trust them in the intended attack.

CHAP. 14. *acie triplici*: this was a march in line of battle (see Fig. 33).—*quid ageretur, what was going on.*

2. *ne . . . an . . . an* (§ 211; G. 460; H. 353): the three infinitives all belong to *praestaret* (Et. 175), *whether it were better.*

4. *quo loco = in this place.*

**76.** *reliqua multitudo*: the presence of women and children shows that it was a migration for settlement, not a mere inroad for plunder.—*ad quos consecrandos* (frequent. of *sequor*), *to hunt them down*, a fit business for the cowardly and treacherous Gallic horse. Referring to this massacre of helpless fugitives, Plutarch writes that, "when the Senate was voting public thanksgiving and processions on account of the victory, Cato proposed that Cæsar should be given up to the barbarians to expiate that breach of faith, that the divine vengeance might fall upon its author rather than upon Rome" (Life of Cæsar).

CHAP. 15. **Germani**, i.e. those who were fighting; **clamore** (Et. 28), i.e. of those who were being massacred.—**reliqua fuga**, further flight.

The reasons are very strong against placing this action in the low lands at the confluence of the Rhine and Meuse (*Mosa*); among them the great distance, more than 120 miles, from the place where Cæsar actually crossed the Rhine. It will make the whole narrative much clearer, to regard this (with Göler) as the confluence of the Rhine and Mosella (*Moselle*) at Coblentz, the ancient *Confluentes*. In this view the text has been confused by the likeness of the names, while Chap. 10 appears to be a note added perhaps by some geographer.

2. **ex . . . timore** = *relieved from* [the apprehension of] *so great a war*.

3. **discedendi potestatem**, *permission to depart*. By this permission Cæsar practically acquits them of the charge of treachery (compare his dealings with the Veneti, Bk. III. Chap. 16). The attack and massacre were purely for "moral effect."—**supplicia** = *vengeance*.

CHAP. 16. **illa**, *the following*.—**justissima**, *most reasonable*.—**suis . . . intellegent**, *he wished them to fear for their own affairs also, since they would understand, &c.* (**cum intellegent** is here nearly equivalent to a participle).

2. **accessit quod** = *and besides*.—**quam . . . transisse**, *which, as I mentioned above* (the conjunction *that* of indirect discourse cannot be used in English to introduce a relative clause). Observe that Cæsar the *writer* uses the first person (**commemoravi**); Cæsar the *actor* is always in the third.—**Sugambrorum**, just north of the Ubii.

3. **qui postularent . . . dederent**, *to require them to surrender those who, &c.* (observe the omission of **ut**: § 331. f. R.; G. 546. R.<sup>3</sup>; H. 499. 2).—**finire**, *was the limit of* (see introd. note, Bk. IV.).—**se invito**, *without his own consent*.—**sui imperii** (pred. after **esse**), *under his power*.

4. **occupationibus reipublicae**, *by the demands of state affairs*.

5. **opinionem, reputationem**.—**navium**, *boats*.

CHAP. 17. *neque . . . esse, it did not belong to his dignity, &c.*

2. *latitudinem, &c.* Cæsar's passage of the Rhine was most probably at Bonn, where the high and rocky banks begin; or at Neuwied, 20 or 25 miles further south, where there is a break in the chain of hills (but here, it is said, the bottom is rock, and not fit for driving piles). The width of the river at either place is about 1400 feet; its depth is very variable. It is now crossed in these parts by floating bridges of boats.

3. *rationem, plan.* The brief description which Cæsar gives of his rough and ready but very serviceable engineering may be made clearer by giving its different points as follows (see Fig. 38):—

1. A pair of unhewn logs, a foot and a half thick (*tigna bina sesquipedalia*), braced two feet apart, and sharpened at the end, are driven with rammers (*fistucis*) into the bottom, sloping a little with the stream (<sup>4</sup>).

2. A similar pair is driven in opposite, 40 feet below, sloping a little against the stream (<sup>4</sup>): the upper ends of the two pairs would thus be some 25 or 30 feet apart, the width of the roadway. Rüstow thinks that the 40 feet refer to the top and not to the bottom of the piles.

3. A beam of square timber, two feet thick (*trabs bipedalis*), and about 30 feet long, is made fast at the ends by ties (*fibulis*) between the logs of each pair,—which are thus kept at a proper distance apart, while they are strongly braced against the current (<sup>5</sup>).

4. A suitable number (probably about 60) of these trestles, or timber-arches, having been built and connected by cross-ties,—this part of the structure must be taken for granted,—planks are then laid lengthwise of the bridge (*directa materia*), resting on the heavy floor-timbers; and upon these, again, saplings and twigs (*longurii, crates*) are spread, to prevent the jar and wear of the carts and hoofs of the pack-animals on the flooring (<sup>6</sup>).

5. Piles (*sublicæ*) are then driven in below, resting obliquely against the logs, to which they serve as shores or buttresses (*pro ariete*), and other heavier piles a little way above, to break the force of floating logs or boats sent down to destroy the bridge (<sup>7</sup>).

*tigna*, probably unhewn logs. — *bina, two and two*, i.e. in pairs. — *pedum duorum*, i.e. between the timbers of each pair.

4. *cum . . . defixerat, &c.* See note on Bk. III. Chap. 9, "The Conjunction *cum*," II. c. 1. — *machinationibus immissa*,

## PONS A CÆSARE IN RHENO EACTUS.

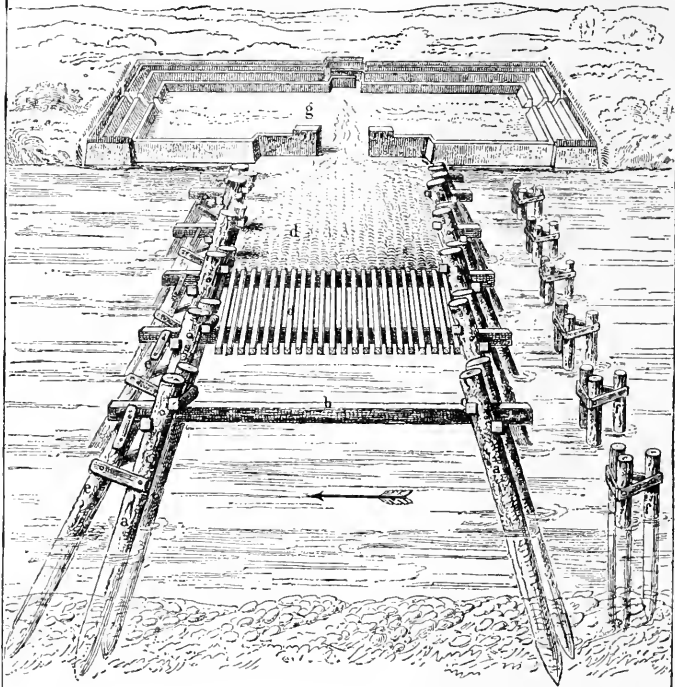

*aa, ligna bina sesquipedalia, bb trabes bipedales. cc. fibulae.  
 dd, directa materia, longioribus crutibusque constrata.  
 ee, sublicae ad inferiorem partem fluminis pro ariete oblique actae  
 ff, sublicae supra pontem immisae.  
 g, castellum ad caput pontis positum.*

Fig. 38.



lowered into the river by machines (boats fastened together in pairs).—**sublicae modo**, like a pile.—**fastigate**, sloping (like the rafters of a house).—**ut . . . procumbent**, so as to fall forward with the current.—**ab inferiore parte**, down stream.

5. **haec utraque . . . distinebantur**, these two sets (or pairs) were held apart by two-foot timbers laid on above, [in thickness] equal to the interval left by the fastening of the beams (**quantum . . . distabat**), with a pair of ties at each end.—**quibus** [tignis] . . . **revinctis**, which being held apart, and made fast again at the opposite end, i.e. the beams held them apart, while the ties kept them from falling asunder.

**78. artius** (= **arctius**), more closely.

6. **haec . . . contexebantur**, these (the framework of timber) were covered with boards lengthwise.—**sublicae . . . agebantur**, piles (or shores) were driven slanting on the lower side, so as to prop the bridge against the current.—**pro ariete**, as a buttress (abutting).

7. **aliae item**, other piles a little way above, to serve as a break-water. There is nothing in the text to show whether these were attached to the bridge or not. Colonel von Cohausen, a Prussian engineer officer, who has made a careful technical study of this structure, thinks that they were, and that **mediocri spatio** refers to the bottom of the river.—**deiciendi operis**, genitive of quality expressing purpose (§ 298. R.; G. 429. R.<sup>2</sup>; H. 544. N.<sup>2</sup>, last example), to throw down the work.—**his defensoribus**, by these defences.—**neu . . . nocerent**, and that they (**trunci**, &c.) might not harm the bridge.

CHAP. 18. **diebus decem** (Et. 8), within ten days.—**traducitur**, the histor. present, resumed from 16<sup>1</sup>.

3. **hortantibus iis**, &c., the few who had escaped the massacre of Chap. 15, and had taken refuge across the Rhine.

CHAP. 19. **succisis**, cut down to the ground.

2. **uti . . . convenirent**, clause of purpose (§ 331. a; G. 546. R.; H. 499) following the verbal phrase **nuntios . . . dimisisse**.—**omnes**, sc. **ut**.—**hunc**, &c., this (the place of meeting) had been selected in the midst, &c.: **medium**, agreeing directly with **hunc**

(§ 193; G. 324. R.<sup>6</sup>; H. 440. N.<sup>2</sup>) in preference to the adverbial phrase in **medio**. — **decertare**: Et. 69.

3. **ut . . . liberaret**, these clauses are in appos. with **rebus iis**.

### 79. **ulcisceretur**, *chastise*. — **rescidit**, *broke up*.

THE LANDING IN BRITAIN. — What is called the First Invasion of Britain, though it marks an interesting date in history, and gave fresh stimulus to Roman curiosity and ambition, was in itself an affair of small account. It was, in fact, only meant for a reconnoissance, or, perhaps, as opening the way to further schemes. Towards the end of summer, Cæsar sailed across to the white cliffs of Dover, coasted a few miles towards the west, and established a camp on the British coast. His cavalry, meanwhile, had been weatherbound in their transports, and then, after crossing, were driven back by rough winds without even coming to land. After holding an uneasy and perilous position for about three weeks, he returned to Gaul, without accomplishing anything beyond a barren display of hardihood.

CHAP. 20. **exiguā . . . reliquā**, *when but little of the summer was left*: ablative absolute (or it might be construed as simple loc. abl., *in the brief remainder of the summer*; illustrating the development of the one construction from the other). — **etsi . . . tamen . . . contendit**, *though the winters are early, yet he made haste to set out*, &c. — **ad septentriones vergit**, *lies near the seven stars* (the north).

2. **omnibus bellis** (loc. abl.), *in almost all*, &c. — **hostibus**, dat. after **sumministrata**, *furnished to the enemy*. — **si . . . tamen**, *even if time should fail, still*, &c. — **magno usui**, dat. of service. — **fore**: the subject is the clause **si . . . cognovisset**, *he thought it would be of great advantage if*, &c.; the pluperfect **adisset**, &c., representing the future perf. **adierit**, following **arbitrabatur**. [Observe in this sentence, that while Cæsar's *action* is given in the perfect (**contendit**), his *reasons* are in the imperfect (**intellegebat**, **arbitrabatur**); while the conditional clauses **si deficeret**, **si adisset**, are strictly *future* conditions carried into the past by the sequence of tenses, § 307. *f*; G. 598. R.<sup>3</sup>; H. 509. N.<sup>3</sup>]. — **quae omnia**, *all of which* (§ 216. *e*; G. 368. R.<sup>2</sup>). — **Gallis incognita**. i.e. except to the secluded and jealous Veneti (Bk. III. Chap. 8).

3. **neque enim** (neg. of **etenim**, § 156. *d*; G. 500. R.<sup>3</sup>), to be rendered with **quisquam**, *for no one*. — **temere**, *without good reason*. — **neque quicquam** = *and nothing*. — **iis**, dat. after **notum** (§ 232. *a*; G. 352; H. 388. 1). — **Gallias**, i.e. Celtic and Belgic Gaul.

4. **vocatis mercatoribus**, &c. = *he called the traders, but could not*, &c. — **quem usum** = *what degree of skill*. — **quanta . . . portus** [Et. 296]: these indir. questions follow **reperire poterat**. Notice that the imperfect **poterat** is used rather than **potuit**; calling attention to his *repeated* questions to the different traders.

CHAP. 21. **periculum faceret**, *making the trial*. — **idoneum**, *a fit person*. — **navi longa**, see Bk. III. Chap. 9<sup>1</sup>. — **quam primum**, *as soon as possible*.

2. **Morinos**, occupying the nearest point to Britain: in clear weather the British coast is in sight from these shores. — **quam classem**, *the fleet which* (§ 200. *b*; G. 618; H. 445. 9). — **qui polliceantur**, *to promise* (§ 317; G. 544; H. 497), followed by **dare** as complem. infin. (§ 330. *f*; G. 527. R.<sup>3</sup>; H. 537. N.), a rare use for **se duros** [esse].

80. 4. **ut permanerent**, to remain, object-clause after **hortatus**. — **Atrebatibus superatis** (see Bk. II. Chap. 23): the same people, it is said, occupied Berkshire in England, whence the supposed influence of Commius. — **ibi**, i.e. among the Atrebates (§ 207. *a*; G. 613. R.<sup>1</sup>; H. 304. III. 2). — **magni**, gen. of indefinite value (§ 215. *c*; G. 399; H. 404), *of great account*.

5. **huic**, indir. obj. of **imperat**; the dir. obj. is the whole clause, down to **nuntiet**. — **fidem sequantur**, i.e. *accept the protection of*, or *submit to*. — **seque . . . nuntiet**, *and tell them that he is coming*.

6. **quantum** (sc. **tantum**) . . . **auderet**, *so far as opportunity could be given to one who did not venture*, &c. (a bit of irony). — **perspexisset**, *had investigated*: for sequence of tenses, see § 287. *e*; G. 511. R.<sup>1</sup>; H. 495. II.

CHAP. 22. **superioris temporis**, *of the season before* (see Bk. III. Chap. 28). — **homines barbari** = *being* (as they were) *barbarians*.

2. **satis opportune**, *seasonably enough*. — **has . . . anteponeudas**, *that occupation about such little matters should be put before* [the invasion of] *Britain*.

3. **coactis**, *gathered* from various quarters; **contractis**, *brought together* into port (at *Boulogne*, or possibly a few miles farther north, at *Wissant*). — **duas legiones**, the seventh and tenth. — **quod . . . habebat**, *all the galleys he had besides*. — **ex eo loco**, &c., *eight miles from there*, at the port of *Ambleteuse*. — **tenebantur quo minus**, *were detained from*. — **equitibus**, *cavalry*, of whom there were 450.

**81. CHAP. 23. idoneam tempestatem**, *favorable weather*. — **tertia vigilia**, *at midnight*. The date was August 26, high water being about half past seven P.M.; the ships, therefore, would go out at about half-tide. — **nactus**: Et. 354. — **solvit**, *loosed or cast-off* the ships: used like our phrase *weighed anchor*. — **equites**: these were to embark at *Ambleteuse*, as above.

2. **paulo tardius**: they sailed after a delay of three days (Chap. 28). — **hora quarta**, about half past eight A.M., about an hour after high-tide. The landing was near Dover, where he lay at anchor till half past three.

3. **montibus angustis**, i.e. cliffs coming close to the shore.

4. **dum . . . convenirent**, *until the other ships should come up* (§ 328; G. 574; H. 519).

5. **ut . . . postularent**, *as military science and especially seaman-ship require*; relat. clause following **monuit . . . administrarentur**, *enjoined that everything should be done promptly*. — **ut quae . . . haberent** (§ 320. e; G. 637; H. 517. 3. 1), *since they have*, &c.

6. **his dimissis**, *when they were sent to their posts* (observe the *dispersive* effect of **di**). — **aestum secundum**: the tide in this place would run west until about half past six. — **ancoris**: Et. 1. — **aperto . . . litore**: "at Lymne in Romney marsh, where the cliffs are far back from the beach, and there is a fine shingle."

**CHAP. 24. essedariis**: the *essedum* was a two-wheeled war-chariot. — **quo genere**, i.e. both horses and chariots, making a sort of flying artillery. — **copiis**, abl. of accompaniment (§ 248. a; G. 391; H. 419. 1). — **egrēdi**, infin. for **ne** or **quominus** with subj.

2. *nisi in alto*, *except in deep water*. — *militibus* (dat. after *desiliendum*), *the men had to leap down*. — *oppressis* (taken with *militibus*), *weighted as they were*. — *simul*: Et. 377. — *cum . . . conicerent*, *while they* (the Britons), &c. — *arido*, *dry ground*. — *insuefactos*, *trained to it*, i.e. to charge to the water's edge.

3. *generis* (gen. after *imperiti*, § 218. a; G. 373; H. 399): *wholly unskilled in this sort of fighting*.

**82.** *pedestribus*, *on land*, where the main strength lay with infantry. — *uti*, *employ or exhibit*.

CHAP. 25. *naves* (obj. of *jussit*, and subj. of *removeri*: see § 240. f. note; G. 532; H. 534), *ordered the vessels to be set back*. — *species*, *appearance*. — *inusitator*, *quite strange*. — *latus apertum*, *the exposed flank*, i.e. the right, unprotected by their shields. — *quae res*, *this manœuvre*.

2. *permoti*, *startled*. — *ac = atque*, *and besides*. — *paulum modo*, *just a little*.

3. *qui ferebat*, *the one who carried*: the antecedent of *qui* is *is*, the understood subj. of *inquit*. — *contestatus*, *appealing to*. — *legioni*, dat. of reference.

4. *prodere*: Et. 225. — *ego certe . . . praestitero*, *I at any rate shall have done*, &c. (see § 281. R; G. 236; H. 473).

5. *inter se*, *one another* (§ 196. f; G. 212; H. 448. N.). — *universi*, *in a body*. — *ex proximis* [primis] *navibus*, *from the nearest ships* (those in the front line). — *adpropinquarunt*: the subject is, [those] *from*, &c.

CHAP. 26. *pugnatum est* = *they fought* (§ 146. c; G. 199. R.<sup>1</sup>; H. 301. 1). — *ab utrisque*, strictly, *by those on both sides*. — *poterant . . . submittebat*: notice the numerous *imperfects* of this description, implying repeated or continuous action. — *alius alia ex navi* = *from different ships* (§ 203. c; G. 306; H. 461. 3). — *quibuscumque signis*, dat. after *occorrebat*; the antecedent noun and pronoun (*eis signis*), if expressed, would be dat. after *adgregabat*. The clause from *quod* to *adgregabat* is a parenthesis.

2. *singulares*, *in scattered groups*. — *adoriebantur* [Et. 414], *would attack*. — *ab latere aperto* (see Chap. 25<sup>1</sup>), *on the exposed flank* of the Romans. — *in universos*, *upon the mass*.

3. **speculatoria navigia**, *swift, light boats for reconnoissance*. Vegetius says that these were painted of a greenish-blue color, to escape notice. The sails and rigging, and even the dress of those on board, were of the same color.

4. **simul** [atque], *as soon as*.

**83. quod equites**, &c.; they were windbound at Ambleteuse (Chap. 22<sup>4</sup>). — **hoc unum . . . defuit**: "in fact, a tide of disasters was now setting in to continue several years."

CHAP. 27. **superati**: Et. 225. — **quae imperasset**, *what he should require* (*quae imperaveris*). — **quem praemisum**, Chap. 21<sup>4</sup>.

2. **oratoris modo**, *in the character of envoy* (or *spokesman*). — **ut [sibi] ignosceretur**, *that [this thing] might be pardoned*: **ignosco** [Et. 120] takes a direct object of the thing, with an indirect object of the person (§ 225. *c*).

3. **bellum . . . intulissent**: these barbarous people might well be pardoned for mistaking Cæsar's expedition as an invasion! — **ignoscere**: for the omission of the subject, see § 336. *a*; G. 527. R.<sup>2</sup> — **arcessitam** = *when they should be fetched*.

4. **remigrare**, *to move back*.

CHAP. 28. **confirmata**: Et. 261. — **post diem quartum**, *i.e. three days after*. — **naves**, &c., see Chap. 22<sup>4</sup>.

2. **aliae . . . aliae**, *some . . . others*. — **sui** (obj. gen. with **periculo**), *to themselves*. — **occasum**, *west*. — **cum . . . compleverunt**, *since they were filling* as they lay at anchor. — **adversa nocte**, *in the face of the night*.

CHAP. 29. **eadem nocte**: this was the night of August 30; the moon was full at 3 A.M.

**84. aestus maximos**, *spring tides*. The ocean tides, rising here between 20 and 30 feet, were a strange phenomenon to those who had known only the tideless waters of the Mediterranean (compare Bk. III. Chap. 8<sup>1</sup>). — **naves**, obj. of **compleverat**. — **adflictabat** (intensive), *dashed about*. — **facultas**, *opportunity* (to do a thing).

2. **id quod**, see § 200. *c*; G. 616. R.<sup>2</sup>; H. 445. 7.

3. **quod constabat**, *because it was settled*: the subject is **opor-**

tere, of which the subj. is *hiemari*, that to winter in Gaul was needful. — *his in locis*: for the order of words, see § 345. a; G. 680. R.<sup>2</sup>; H. 569. II.

CHAP. 30. *principes*, subj. of *duxerunt*. — *hoc angustiora*, so much the smaller: *hoc* is abl. of deg. of dif. (§ 250; G. 400; H. 423). — *optimum*, in pred. agreement with *frumento . . . producere*. — *duxerunt*, thought. — *frumento commeatu*, corn and other supplies. — *rem*, the operations. — *his . . . interclusis*, abl. abs. of condition: if these should be overcome, &c. — *rursus*, not a second time, but back from negotiations to hostilities. — *clam*: Et. 29. — *deducere*, bring down towards the coast.

CHAP. 31. *ex eventu navium*, from what had befallen the ships. — *ex eo quod*, from the fact that. — *suspicabatur*, began to suspect. — *subsidia comparabat*, made provision.

2. *quae . . . naves, earum, &c.*, the timber and bronze of those ships which, &c. (§ 200. b; G. 618; H. 445. 9). — *aere*: the Romans used *aes* indiscriminately for copper and bronze. These metals were more common than iron in the Roman ships. They were employed to sheathe the *rostrum*, and in the spikes that held the timbers together. — *materia*: Et. 396. — *quae . . . usui*, whatever was of use: the antecedent of *quae* is *ea*, subj. of *comportari*.

85. *reliquis . . . effecit*, he managed so that they could sail (*navigari*, impers.) tolerably with the rest.

CHAP. 32. *geruntur*, § 276. e; G. 220. R.<sup>1</sup>; H. 467. III. 4. — *frumentatum*, to get grain (supine). — *pars hominum*, some of the people. — *ventitaret*, returned from time to time (frequent., § 167. b; H. 336). — *pro*, in front of. — *quam . . . ferret* = than usual.

2. *id quod erat* = what was the fact. — *aliquid . . . consilii*, that some new design was undertaken. — *ex reliquis duas*, two of the others. — *armari*, to arm; in verbs, thus used reflexively, English prefers the active and Latin the passive form.

3. *paulo longius*, some little distance. — *premi . . . sustinere*, were getting pushed, and hardly held their ground. — *conferta legione* (abl. abs.) = the legion was formed in solid square, while

*weapons were hurled, &c.* Observe the force of Latin, in conveying a description, as here, by a participial phrase.

4. **suspicati**, *supposing* (§ 290. *b*; G. 278. R.; H. 550. N.<sup>1</sup>). — **dispersos, occupatos**, *while scattered, &c.*, agreeing with **milites**, governed by **adorti**. — **incertis ordinibus** (abl. abs.), *because the ranks were unsteady*.

CHAP. 33. **ex essedis**: these chariots are often represented with scythes at the axle, of which Cæsar makes no mention. They held six men (*essedarii*) each, besides the driver (*auriga*), and were

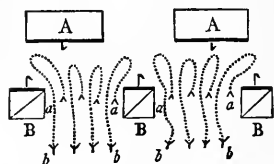

Fig. 39.

*The Attack with Chariots.*

A A. Roman Infantry.

B B B. British Cavalry.

*a b, &c.* Course of the Chariots.

*a a, a a a.* Post of the dismounted *Essedarii*.

*b b, b b b.* Post of the Chariots.

drawn by two horses. — **cum se insinuaverunt**, *when they have worked themselves among*. For perf. indic. with **cum**, see "The Conjunction **Cum**," note on Bk. III. Chap. 9.

2. **equitum**, the cavalry of the Britons. When the *essedarii* had dismounted, the British line was composed of alternate bodies of horse and foot (see Fig. 39). — **paulatim**, *little by little* (§ 148.  $\epsilon$ ; H. 304. I. 1). — **illi**, i.e. the fighting men spoken of above. — **expeditum receptum**, *a ready retreat*.

3. **praestant**, *exhibit*. Cæsar was much struck with the efficiency of the German and British horse (see Chap. 12), and made it the basis of important changes in the Roman army. — **uti . . . consuerint**, clause of result following **efficiunt**. — **declivi ac praecipiti** [Et. 52] **loco** = *a steep downward slope*. — **incitatos equos sustinere**, *to check their horses in full gallop* (infin. after **consuerint**). — **brevi**, *within a short space*.

86. CHAP. 34. **quibus rebus**, *under these circumstances* (loc. abl.). — **nostris**, dat. following **tulit auxilium**.

2. **alienum . . . arbitratus**, *judging it an unfavorable time*. For this force of **alienum** see note on Bk. I. Chap. 15<sup>2</sup>.

3. **quae continerent**, *so as to keep* (§ 319; G. 633; H. 500. I.).

4. **praedicaverunt** [Et. 10], *bragged about*. — **quanta . . . fa-**



**cultas daretur**, *what opportunity was offered* (indir. question following **demonstraverunt**).

CHAP. 35. **ut effugerent** (in appos. with **idem**, the subj. of **fore**), *namely, that if*, &c. — **effugerent**, *would escape*: the future signification is from the effect of **fore**. — **equites triginta**: these few cavalry would be of no service in an engagement, but only in pursuit. To chase and cut down the beaten army was considered an essential part of the battle.

3. **tanto spatio**, *over as much ground* (§ 257. *b*; G. 387; H. 379. 2).

CHAP. 36. **duplicavit**: Et. 231. — **die aequinoctii**, the stormy season (Sept. 24). “Cæsar had therefore been nearly a month in Britain, without being able to advance a mile from the shore.” Napoleon III. estimates that the return to Gaul occurred Sept. 11 or 12. This would make the stay about three weeks. — **hiemi**, &c., *thought the voyage ought not to be exposed to foul weather*.

87. 2. **eosdem . . . portus**, *the same ports with the others*: **reliqui** is masc. (by *synesis*) as referring to **milites**; some editions have **reliquae** [*naves*].

**paulo infra**: “the west current sets in on the French coast, while that to the east is still running in mid-channel.”

CHAP. 37. **expositi**, *landed*. — **circiter trecenti**: From this statement we may make a pretty close estimate of the number of men in a full legion. Cæsar tells us that he had 80 transports for his two legions. By the storm 12 ships were lost. These 12 were probably transports, as they were at anchor, and hence more exposed to danger. That would leave 68. From the two that were separated from the fleet, about 300 men were landed. At that rate, in the 68 ships there must have been 10,200 men. As the legions were without heavy baggage, there would have been no servants excepting for the officers. Allowing for these, and for the number of officers in the general staff, there would remain not much less than 5000 men in each legion. We see thus that Göler's estimate of 4800, as the normal number in the legion, was not far from the truth. — **non ita magno**, *not very large*. — **numero**: Et. 360.

2. **orbe**: the circle was formed by a small body of troops when entirely surrounded by the enemy. It was generally hollow, with officers and baggage in the centre.

3. **horis**, abl. of comparison with **amplius**: a more common construction would be **horas**.

4. **postea quam** = *as soon as*.

CHAP. 38. **siccitates**: see § 75. *c*; G. 195. 5; H. 130. 2.—**superiore anno**, see Bk. III. Chap. 28<sup>2</sup>: the **tempestates** of Chap. 34 were apparently merely gusty weather without rain.

3. **supplicatio**: compare end of Bk. II.

The crossing of the Rhine had strongly impressed the minds of the Romans, and so too the passage into Britain, though in fact a failure. This unprecedented thanksgiving of 20 days we must remember, however, was voted by Cæsar's own party, who now held all the offices, and who would wish to cover up the impression of any ill success. In fact, though he had added nothing to Roman power, he had opened a new world to Roman ambition.

THE LEGIONS.—In the campaign of the year 55 B.C., Cæsar had still under his orders the eight legions before mentioned. How many of these were engaged in the expedition against the Germans we do not know. Legions VII and X composed the detachment with which Britain was reconnoitred (Chap. 25<sup>3</sup>, Chap. 32<sup>1</sup>).

## BOOK FIFTH. — B.C. 54.

SECOND INVASION OF BRITAIN. — The landing of the previous year had been only a reconnoissance. Cæsar now determines upon a regular advance and occupation. The earlier part of the season was chiefly taken up with naval preparations, the ships being apparently (Chap. 5<sup>1</sup>) built on the inland streams, and the rigging and outfit brought from Spain (Chap. 1<sup>3</sup>), which was considerably in advance of Gaul in civilization, abounded in metals, and, in particular, furnished the *esparto*, or Spanish grass, whose long, tough fibre made the best of cordage. Cæsar sails (by the reckoning of Napoleon III.) on the 20th of July from *Portus Ilius*, at or near Boulogne, drifting first with wind and tide some distance to the N.E., then returning to the locality of his former landing (Chap. 8<sup>3</sup>).

**88.** CHAP. 1. **L. Domitio**, &c. The consuls entered on their office Jan. 1, according to the official calendar; the real date appears to have been Dec. 12. Cæsar's visit to Italy was probably later. — **naves . . . curarent**, HAVE *vessels BUILT and the old ones REPAIRED*. See note on Bk. I. Chap. 13. — **modum formamque**, *style of build* (hend).

2. **subductiones**, *hauling ashore*: they were not left at anchor. (For the plural form, see § 75. c; G. 195. R.<sup>5</sup>; H. 130. 2.) Compare **naves subducere**, *to haul ashore*, and **deducere**, *to haul down*, i.e. *to launch*. See Chap. 2<sup>1</sup>. — **nostro**: i.e. Mediterranean. — **minus magnos** seems to refer to the smooth ocean swell, compared with the angry "chopping seas" of the Mediterranean. — **id**, sc. **facit** (206. c; H. 368. 3. N. 1).

3. **actuarias**, *driven* by oars as well as sails, hence *swift*. The Gallic ships, it will be remembered, did not use oars. See Bk. III. Chap. 14<sup>6</sup>. — **humilitas**: as compared with the high-banked galleys. These of Cæsar had only one bank of oars. — **armandas**, *rigging* (see above).

**89.** 4. **conventibus**, proconsular or provincial *courts*; the same name is given to the *districts*. These courts were regularly held in the winter (compare Bk. I. Chap. 54). — **Illyricum**: Cæsar's province included all to the N.E. as well as N.W. from

Italy. — **Pirustis**: a tribe long allied with Rome, inhabiting the valley of the *Drina*. — **civitatibus**, § 225. *c*; G. 347; H. 384. 2. — **certum**, *designated (cerno)*: observe the passive meaning.

6. **percepta**, *listened to attentively*.

7. **arbitros**, *umpires*; **litem**, *amount of damages*.

CHAP. 2. 2. **circuitis**, *having inspected*: see § 237. *d*; G. 330; H. 372. — **studio**, &c.: this abl. phrase qualifies **instructas**. — **deduci**, *launched*; lit. “hailed down” on rollers to the water.

3. **Itium** (see above): Boulogne, Wissant or Ambleteuse, no matter which (compare Bk. IV. Chap. 23). — **triginta**: a little less than 28 English miles.

4. **Treverorum**, a tribe reckoned as Gauls or Celts (see Bk. VIII. Chap. 25), but believed to be, in part at least, of German origin, and giving their name to the modern *Trèves*. Their chief town (*Augusta Treverorum*) was long the chief seat of Roman power in Northern Gaul. — **concilia**, *assemblies*, held by a province or confederacy for consultation or law-making. Cæsar appears to have organized such assemblies under his own authority in Belgic Gaul after its conquest. — **veniebant**, &c.: notice the imperfect tense. — **dicebantur**: for the personal form, see § 330. *b*; G. 199. 3; H. 534. I. N. I.

CHAP. 3. **ut supra demonstravimus**, Bk. III. Chap. 11<sup>1</sup>.

2. **alter**, *the latter*, Cingetorix. — **suos**, i.e. clansmen, retainers, &c. Cingetorix offers to bring his nation under Roman authority on condition of ruling them himself as a subject or “friend” of Rome.

90. 3. **Arduennam**: this hilly and forest region makes the natural frontier between Gaul and the Netherlands, and is the seat of the famous Belgian iron-mines. — **medios**, see § 193; G. 287. R.; H. 440. N. I.

5. **laberetur**, *fall off* (from obedience). — **imprudentiam**, *ill-judgment*. — **ita-que**, *and in consequence*. — **se permissurum**, *to put . . . under his protection*.

CHAP. 4. **omnibus . . . comparatis**, *now that*, &c.

3. **cum . . . intellegebat**, *considered on the one hand*. (See

“The Conjunction **Cum**,” note on Bk. III. Chap. 9.) — **merito ejus** = *as he fairly deserved* (see § 253; G. 398; H. 424).

4. **suam . . . minui**, in appos. with **id factum**. — **qui . . . fuisset** = *while*, &c. (see § 320. e; G. 637; H. 515. III.). — **dolore**, *grievance*.

**91.** CHAP. 5. 2. in **Meldis**: these were on the *Marne*, near Meaux. The ships were built here, probably, for convenience of timber; they were low and of light draft (Chap. 1), and proved too frail for the Channel waters (Chap. 10; compare Bk. III. Chap. 9, where sturdier craft are built upon the Loire).

3. **numero**, abl. of specification; **milium** limits **equitatus**. — **loco**, in the condition (§ 254. a; G. 385. R.; H. 425. 2). — **cum . . . abesset**, *while he should be away* (a fut. cond. following **verebatur**).

CHAP. 6. **Dumnorix**: he appears to have been kept four years under close surveillance (see Bk. I. Chap. 20, end).

2. **neque . . . audebant**, *and yet dared not*.

3. **timeret, diceret**: § 341. d. R.; G. 541; H. 516. II. — **religionibus**, *by religious scruples*.

4. **sollicitare; territare; esse**: notice the different construction of these three infinitives. — **causa**, *purpose*. — **feri ut**, *it was coming to pass that*, &c.

5. **ex usu**, *to the advantage*. — **intellexissent** here represents the fut. perf. of direct discourse.

CHAP. 7. **quod . . . statuebat**: the severity to Dumnorix was proportioned to the favor and consequence granted to his State.

**92.** 2. **commoratus**, i.e. during the delay (compare § 290. b; G. 278. R.; H. 550. N. 1). — **Corus** (or *Caurus*), the north-west wind. — **omnis temporis**, *every season* of the year: the wind-mills on this coast had their sails set permanently to the N.W. (Moberly).

3. **milites equitesque**: the *milites* were the legionary infantry.

4. **pro sano**, *rationally*. — **neglexisset**: the tense depends on **arbitratus**, which is, however, present in meaning (see note on **commoratus**).

5. **enim** = *in point of fact*. — **liberum**, &c. Cæsar takes no pains to conceal the violence of his own acts. He had no authority over Dumnorix except that of the stronger.

CHAP. 8. 2. **pari . . . quem**, *the same . . . as* (i.e. 2000). — **Africo**, the south-west wind. — **sub sinistra**: i.e. he had drifted to the north-east (see map).

Cæsar weighed anchor at sunset (about 8 P.M.). A gentle breeze was then blowing from the S.W.; but at the same time a tidal current was setting *towards* the S.W. Under the impulse of these two forces, the fleet kept a north-westerly course until about midnight. The wind then died down, and the current also began to set in the opposite direction (N.E.). With this current the Romans drifted, and at dawn the British coast appeared on their left. They had passed by (*relictam*) the North Foreland, and were drifting farther away from the land. But at about this time (5 A.M.) the tide changed, and the current again began to flow towards the S.W. With its help, and that of the oars, the fleet now began to move towards the land, aiming to reach the same point that had been found in the previous expedition to be the most convenient for debarking. Here they arrived at about noon (Göler).

4. **gravibusque** = *and that, too, heavy-laden*. — **navigiis**, abl. of means.

93. 5. **accessum est**: the landing was at *Romney*. — **annotinis**, *those built the year before*. — **sui commodi**, sc. **causã**; or, **commodi** is a genitive of purpose.

CHAP. 9. **cohortibus decem**, i.e. two from each legion.

2. **flumen**: the *Stour*, which flows north-easterly through Canterbury, forming at its mouth the Isle of *Thanet*. — **superiore**: the north bank is higher ground than the opposite.

4. **testudine facta et aggere . . . adjecto**:

From the rapidity with which this *agger* was completed, it is evident that it was not the elaborate structure required in attacking more formidable defences, as described in the note on Bk. II. Chap. 12. We may also infer that the British stronghold was only rudely fortified. The method of attack seems to have been as follows: —

The men in each file stood close together, but with a space of about 3 ft. between the files; excepting, of course, in the front rank, where the

formation would be solid. This first rank held their shields in front of them. The other shields were held overhead, the length at right angles to the file. Thus between each two files a protected space, 3 ft. wide, was left, through which workmen could carry brush and fagots. This being rapidly piled, the soldiers kept mounting, stepping alternately to right and left, as the clear space was filled and the place where they were standing was needed. Thus in a short time the *testudo* was on a level with the top of the wall, and the ditch was filled up. Then a rush drove the enemy easily from their works, and the position was taken.

CHAP. 10. *tripartito*, i.e. *in three columns*, following different roads.

**94.** CHAP. 11. *sic*, &c.; i.e. *true to the extent that*, &c.

2. *fabros deligit*: a certain number of carpenters (*fabri lignarii*) was always attached to the engineer corps of the army. The use of *deligit*, however, seems to imply that there were too few for the present emergency, and hence there were selected from the ranks a sufficient number of men skilled in such work.

3. *subduci*, *drawn up* on the beach. See note on Chap. 12.

4. *eodem*; i.e. to the British defences on the Stour.

5. *a mari*, from Cæsar's place of landing. The distance is reckoned, not in a straight line, but by the roads, as the army marched.

6. *huic . . . intercesserant*: "The brave and cautious prince Cassivellaunus [*Caswallon*], who ruled in what is now Middlesex and the surrounding district, — formerly the terror of the Celts to the south of the Thames, but now the protector and champion of the whole nation" (Mommsen).

CHAP. 12. *natos in insula*: they were not, however, indigenous, but a Celtic population following an earlier Iberian race. — *iis nominibus*: for example, *Atrebates* and *Belgæ*.

**95.** 3. *Gallicis*: brief references to the Gallic customs of building are made in Bk. V. Chap. 43<sup>1</sup>, and Bk. VI. Chap. 30<sup>3</sup>. — *nummo aereo*: this doubtful phrase is found in some good authorities, in the very doubtful form *aureo*. — *plumbum album*: Cæsar is mistaken in placing tin-mines inland and iron on the coast; it

was just the other way. He does not say whether iron was used in the arts, which would imply a pretty advanced civilization.

4. **fagum atque abietem**: another error; the beech and fir are both native to Britain. — **animi, fancy**. — **frigoribus, seasons of cold**.

CHAP. 13. 2. **ad Hispaniam, &c.** For this crude geography compare Tacitus (Agric. 34), who says that Ireland is between Britain and Spain. — **atque, as**, § 156. *a*; G. 646; H. 554. I. 2. N.

3. **Mona, the Isle of Man**. Tacitus, apparently, gives this name to *Anglesea*.

4. **ex aqua mensuris**: the *clepsydra*, or water-clock, measured time by the dropping of fixed measures of water through a small pipe, or aperture.

CHAP. 14. 2. **interiores**: the ruder barbarians here described are probably represented by the later *Picts*, whose name (*pictis*) has been thought to denote their woad-staining.

“A painted coat King Vortigern had on,  
Which from a naked Pict his grandsire won.”

3. **parte**, § 251; G. 402; H. 419. II.

96. 4. **uxores habent, &c.** This rude and early nucleus of the clan “was founded upon the intermarriage of several brothers to each other’s wives in a group, and of several sisters to each other’s husbands in a group. But the term *brother*, as here used, included the first, second, third, and even more remote male connections, all of whom were considered brothers to each other, as we consider own brothers” (Morgan’s “Ancient Society”). One effect of the arrangement was a great check upon population, — an important point with all barbarians. — **quo** (adv.) here stands for **ad quos** (§ 207. *a*; G. 613. R. I; H. 304. II. 3. N.).

CHAP. 15. **essedarii**: see Bk. IV. Chap. 33. — **fuerint**, § 287. *c.* with Rem.; G. 513; H. 495. VI.

3. **atque his, and these, too**. — **primis**: the first cohorts had the best soldiers. See note on the “Relative Rank of the Centurions,”



Bk. I. Chap. 40. — **per medios**, i.e. through the interval between the two cohorts.

CHAP. 16<sup>3</sup>. **cedentibus et insequentibus**, agreeing with **eis** understood (abl. abs.), referring to the Britons. Whether advancing or retreating, the islanders were equally formidable.

4. **stationes, supports**. It will be observed that the Britons showed considerable military skill, and that their mode of battle somewhat resembled that of the Romans themselves. They used an open and flexible array, rather than the dense masses (*phalanges*) of the Gauls and Germans.

97. CHAP. 18. **uno loco**: somewhere between Brentford and the mouth of the *Wey*. The details of Cæsar's march are here uncertain: as Mr. Long thinks, he went by the passage of the *Mole* through the chalk hills at Dorking.

2. **sudibus**: these defences, or palisades, have been thought to be indicated by the local name *Cowey Stakes*, near the junction of the *Wey* with the *Thames*. These, however, were at right angles with the bank, as if piles for a bridge; while those spoken of in the text were driven in along the bank—one of the rows at low water.

4. **capite solo**, a most hazardous depth. By the rule for modern infantry, a ford should not be more than three feet deep. But, says Merivale, "the swimming and fording of rivers were among the regular exercises of the Roman legionary. Though immersed up to his chin in water, he was expert in plying his hatchet against the stakes which opposed his progress, while he held his buckler over his head not less steadily than on dry land. Behind him a constant storm of stones and darts was impelled against the enemy from the engines which always accompanied the Roman armies."

CHAP. 19. **locisque impeditis ac silvestribus**: from this description we must infer that the British chariots were very narrow, to pass through the forest roads; and had very high wheels, to go easily over rough ground.

2. **cum . . . ejecerat**. See note on Bk. III. Chap. 9, "The Conjunction **Cum**," II. c. 1.

CHAP. 20. **Trinobantes**: in *Essex*. Their chief place was *Camalodunum*, now Colchester. — **Imanuentius**: this name is found in later Mss., and is not given in Nipperdey's text.

2. **qui praesit**: this defection of Mandubracius was soon followed by the break-up of the Briton confederacy.

CHAP. 21. **Icani**, &c. These local names vaguely hint at the petty populations of the vicinity. — **oppidum Cassivellauni**: thought to be the modern St. Albans.

2. **oppidum**, &c. The Britons, like the Germans, did not live in towns, but used these strongholds simply for defence against attack. — **cum**: see note on Book III. Chap. 9, "The Conjunction **Cum**," II. c. 1.

**99.** CHAP. 22. **regionibus**: implying that Kent (*Cantium*) was divided into four recognized military commands.

4. **neque multum aestatis**. Cæsar had now apparently been in Britain about two months (compare Chap. 23). The dates assigned by Napoleon III. for his sailing and return are July 22 and Sept. 24; or, by the reformed calendar, July 20 and Sept. 21. — **extrahi**, *protracted*, i.e. wasted. Besides, Cæsar had just learned the death of his daughter Julia, Pompey's wife, threatening the dissolution of the triumvirate, and giving him strong reason for wishing to be nearer home.

**vectigalis**: this was mere form, as no means were left to enforce the tribute.

FRESH RISINGS OF THE GAULS. — The remaining events of this campaign are among the most critical of the entire Gallic war, and show to what extreme peril Cæsar had exposed his conquests by his nearly idle and fruitless expedition across the Channel. They serve, besides, to bring out, in very marked relief, the personal qualities of his several lieutenants. As a series of episodes, this Book is, in fact, the most interesting of the eight.

**100.** CHAP. 24. **Samarobrivæ**, the chief town of the *Ambiani*, whose name is found in the modern *Amiens*. — **aliter ac**: i.e. not where supplies were most abundant, but where there was chief danger of disturbance.

2. **Q. Ciceroni**, the younger brother of the orator, and a man of harder temper. He had joined Cæsar's army the present year, and taken part in the expedition to Britain.

3. **proxime, latest**. This was the 15th legion. — **trans Padum**, i.e. from Rome to the north.

CHAP. 25. **restituerat**: this act of "restoring" chiefs exiled by the democracy of the tribes was peculiarly odious, as here appears.

2. **auctoribus**, either at their instigation, or at any rate with their full consent.

**101.** CHAP. 26. **diebus . . . quibus, within a fortnight after,** &c. — **praesto, in attendance upon**, as obedient subjects. — **Indu-tiomari**: for the bitter offence given him by Cæsar, see above, Chap. 4.

3. **aliqui**: the usual form is **aliquis** (§§ 104, 105. *d*; G. 105; H. 190. N. 2).

CHAP. 27. **eques, a knight**, a member of the "equestrian order," the commercial aristocracy of Rome.

3. **imperia, sovereignty**. The word is used in English abstractly, referring to all cases; while in Latin each sovereignty is regarded as a separate *imperium*.

**102.** 4. **humilitate, weakness**.

5. **alterae, dat.** (notice the form). — **cum**: see note on Bk. III. Chap. 9, "The Conjunction **Cum**," II. *a*. 2.

6. **pro pietate**: *pietas* implies the love of a child to a parent; here, of course, to his native land. — **rationem officii** = *regard to his duty*. — **conductam, hired, or subsidized**.

CHAP. 28. 2. **consilium**: as the two legates had  $1\frac{1}{2}$  legions under their command, the council of war contained, besides the legates, 9 military tribunes, and either 9 or 6 centurions, according as the half legion did or did not include the first cohort. Thus there were in the council either 20 or 17 persons.

**103.** CHAP. 29. **proximis, close at hand**.

2. **fuisse capturos**: the direct discourse would have *cepissent*, and for **venturos esse, venirent**.

3. **auctorem**, as the informant. — **spectare**, sc. **se**. — **ardere**, is in a blaze. — **Ariovisti mortem**: he had, however, escaped after the battle (Bk. I. Chap. 53).

4. **persuaderet**: for the form of question, see § 338. R.; G. 468; H. 486. II.

CHAP. 30. **primis ordinibus** = *primorum ordinum centuri-  
onibus*.

**104.** CHAP. 31. 2. **dat manus** (a formal sign of surrender), gives in. — **pronuntiatur**, the order is given out.

4. **ut quibus**, &c. (§§ 320. e, 230; G. 637, 208; H. 515. III., 384. 5), as if, &c. — **longissimo**: the line of march was very long, and consequently very weak.

CHAP. 32. **convallem**: a valley enclosed on all sides. In this sink of course the Romans were at a disadvantage.

**105.** CHAP. 33. **providisset**: for the subj. see § 341. d; G. 636; H. 517.

3. **in orbem**: see note on Bk. IV., Chap. 37. A modern army would form a hollow square. The circle was hollow, having room within for the higher officers, the non-combatants, the wounded, &c.

CHAP. 34. **existimarent**, for imperat. of direct discourse (§ 339; G. 655; H. 523. III.).

2. **et virtute et numero**, abl. of cause.

3. **ad signa recipientes**: the standards were fixed in the ground, thus indicating the alignment of the circle.

CHAP. 35. **cum . . . excesserat**, as often as, &c., equivalent to a general condition (§ 309. c; G. 585; H. 521. II. 1, with last example; also see "The Conjunction **Cum**," note on Bk. III. Chap. 9). — **recipi**: "*recipe ferrum* was the cry to a gladiator who was not to be spared" (Moberly).

4. **qui . . . duxerat**: as he had been chief centurion the year before, we infer that he was now serving in the corps of veterans called *evocati*. See Bk. VII. Chap. 65.

CHAP. 37<sup>3</sup>. **ululatum**: such a yell of triumph is described by

Ammianus (XVI. 12, 43): "It began with a low humming, growing gradually louder and louder, until it was like the thunder of the waves, when they crash on a rocky shore."

**107.** CHAP. 38. *neque noctem neque diem intermittit.* Ambiorix marched only one night and one day. More than that would have been expressed by *nocturnis diurnisque itineribus* (cf. Bk. I. Chap. 38).

2. *in Nervios.* Cæsar had said (Bk. II. Chap. 28) that the Nervii were almost utterly exterminated (*prope ad internecionem redacti*) three years before. From this it is inferred that "he wrote his Commentaries at the time of the events, and did not correct them afterwards" (Long). Or they may have been drawn up from his despatches to the Senate, which were sent at the close of each campaign (Roscher). See note on Bk. II. Chap. 1.

3. *oppressam . . . interfici:* render by two verbs, *to be surprised and slain* (§ 292. R.; G. 667. R. 1; H. 549. 5).

CHAP. 40. 2. *turres:* these "were open at the sides and behind, solidly timbered towards the enemy, and their object was, like that of the modern bastion, to shorten the length of wall to be occupied by the defence" (Moberly). Others think that their use was to give the soldiers a still higher position from which to throw their missiles. In this case, if made like those described by Pansa in Bk. VIII. Chap. 9, they would have been of not more than three stories, or perhaps 30 ft., high. Each story was floored with a platform, on which the soldiers stood. The front and sides of each platform were protected by a parapet (*loricæ*) of hurdles, to the height of about 4 ft. Above this projected a sort of battlement of stakes (*pinnae*), or of hurdles standing erect, with spaces at intervals, through which the spears were hurled. The structure was square, of about 10 ft. on a side. Of these towers it appears that on the first night only the framework was erected. On succeeding nights they were completed.

**108.** 3. *muralium pilorum,* long pikes, to defend the wall.—*contabulantur,* floored with plank. Possibly also the towers were connected by galleries, one for each story.

CHAP. 41. 3. nihil . . . recusent: i.e. they will be friends, but not subjects; they only refuse to admit a standing military force.

CHAP. 42. fossa pedum quindecim: a ditch 15 ft. wide would be 11 ft. deep. See note on Bk. I. Chap. 49.

2. nulla . . . copiã = *having no supply*, &c. (a sort of abl. abs.). — manibus sagulisque . . . exhaurire, *to take up with the hands and [carry] in the cloaks*. A case of *zeugma*, Gr. p. 298; G. 690; H. 636. II. 1.

109. 3. quindecim: probably an error, as a circuit of 15 miles seems out of the question; perhaps pedum, or quinque. — falces, *hooks*, for tearing down the wall. — testudines, *wooden galleries or sheds*, to protect the undermining (see Fig. 26).

CHAP. 43. casas, the *huts* of the encampment, thatched with straw.

2. clamore: see note on Chap. 37<sup>3</sup>.

110. CHAP. 44. 2. locum, *opportunity*.

CHAP. 45. 2. a prima obsidione, *at the beginning of the siege*.

111. CHAP. 46. milia passuum xxv, i.e. from Amiens to Montdidier.

CHAP. 47. 4. quos . . . sciret = cum eos sciret. — veritus ut, § 331. f; G. 552; H. 498. III. N. I.

5. quanto . . . esset, indir. quest. depending on the verb of *telling* implied in litteras remittit.

CHAP. 48. opinione, *expectation*.

112. 4. Graecis litteris, i.e. *in Greek letters*. The Gauls were well acquainted with the Greek characters (Bk. I. Chap. 29; Bk. VI. Chap. 14). According to Polyænus the despatch contained merely the words, "Cæsar to Cicero. Be of good courage. Expect aid."

5. amentum: the *amentum* was a small strap fastened to the middle of a light spear. By its use the spear could be thrown twice as far as without it, as has been proven by experiment.

6. *biduo*, within two days (§ 256; G. 392; H. 429).

7. *perlectam . . . recitat*: he read it through (to himself), and then recited it aloud in the assembly of the soldiers.

**113.** CHAP. 49. 2. *Gallum . . . repetit*, asks again for the Gaul.

6. *milium septem*: the legions averaged, then, 3500 men each, and this was less than the normal strength. The latter was quite likely at least 4800. See note on Bk. IV. Chap. 52. — *angustiis viarum*, i.e. narrow paths or streets within the camp. See note on Bk. I. Chap. 49.

CHAP. 51. 3. *nemo*, not a man (emphatic by position).

**114.** CHAP. 52. 3. *pro ejus merito*: Cicero's admirable conduct here receives as high praise as it was Cæsar's habit to give anybody.

4. *laetatio*: this word occurs nowhere else in any classical author.

CHAP. 53. 3. *trinis*, see § 95. *b*; G. 95. R. 2; H. 174. 2. 3. — *ad exercitum manere*, contrary to his usual course, which was, for political reasons, to keep in near communication with Italy.

**115.** 6. *longius*, sc. *quam* (as after *plus*, *minus*, *amplius*).

CHAP. 54. 2. *adventu* (loc. abl.) = *at the time of*, &c.

5. *adeo* (emphatic), *in fact*. — *ei*, nom. — *præferébantur*, used to be held superior. The old terror of the Gallic name was, indeed, rather confirmed by the ferocity of the hostility which Cæsar met, especially in Britain, where his two legions had been cut down to "scarcely 7000 men" (Chap. 49).

**116.** CHAP. 56. *ultro veniri*, a spontaneous rising for his support.

4. *Senonibus, Carnutibus, Sens and Chartres*.

**117.** CHAP. 58. 3. *præcipit* refers to *peterent*; *interdicit* to *neu vulneret*. — *morā reliquorum*, by waiting to attack the others.

THE LEGIONS. — In the year 54 B.C., probably in the spring, Cæsar enlisted one new legion, the 15th. The 14th was divided. Five of its cohorts were scattered, the men being used to fill up the depleted ranks of the other legions. Thus Cæsar had in all eight and a half legions under arms. Of these, fifteen cohorts (legion XV and five cohorts of legion XIV) were destroyed with Sabinus,

## BOOK SIXTH. — B.C. 53.

SECOND PASSAGE OF THE RHINE. — The last campaign, including the bootless return from Britain, and the slaughter of the division of Sabinus, must have been in the eyes of the Gauls at least as good as a drawn battle, and have given them fresh hope in the struggle. The strength of their resistance was in the north and east, where they had the support of raids from across the Rhine, — a falling back on barbarism which it was especially the business of Cæsar to check by a daring blow. Hence the policy of this new, but idle, advance into Germany. It may be borne in mind that this campaign was the more critical, as following closely upon the defeat and destruction of the Roman armies under Crassus in the East.

CHAP. 1. **multis de causis**: viz. the desertion of Dumnorix, the loss of Cotta and Sabinus, and the sudden revolt led by Indutiomarus (see above). — **dilectum**, i.e. in Italy.

2. **proconsule**: Pompey had been consul B.C. 55. He was now *nominally* proconsul of Spain, with six legions; but remained in Italy, ruling his province through *legati*. It was at this time that he built his great wooden amphitheatre in Rome, capable of holding 30,000 spectators. — **ad urbem** (not *in urbe*): as long as he was in military command (*cum imperio*), he might not enter the city — which in such case had only been done by Sulla. — **reipublicæ causâ**, the superintending of the corn supply (*cura annonæ*). — **Cisalpina Gallia**, Cæsar's own province. But Pompey and Crassus had received authority to raise troops where they pleased, and in whatever number. The jealousies arising from this transfer of troops had fatal consequences afterwards. — **consulis . . . rogavisset**: the verb **rogare** is used of the magistrate who puts a proposed law to vote; literally, "asks" the people if they will accept it (*jubeatisne?*); also of a commander who demands of his men whether they will be bound to him by oath. The genitive (*consulis*) indicates the magistrate or officer who imposes the oath; on the part of the soldiers the expression would be, **in verba consulis jurare**. — **juberet** follows **petit** (sc. **ut**); its object being the antecedent (*eos*) of **quos**, above.



3. **opinionem Galliae**, *reputation in Gaul* (subj. gen.). — **videri**, *be seen* (not *seem*). — **adaugeri** refers not to “damage” (*detrimenti*), but to Cæsar’s forces (implied). [This linking of different subjects under one construction is called *zeugma*.]

4. **amicitiæ**: Cæsar and Pompey were still openly friends, though by the recent death of Julia (Cæsar’s daughter and Pompey’s wife), as well as by the death of Crassus, the political coalition which united them was dissolved, and an open rupture soon followed. The legion now forwarded to Cæsar was demanded back two or three years later. — **duplicat**: 15 cohorts were lost under Titurius. The three legions now received of course had 30. The new legions sent by Pompey were known as the 1st and 3d. Another, raised by Cæsar, was the 14th; taking the same number as the legion the half of which had been lost under Titurius at Aduatuca. The other half, it will be remembered, had been used to fill up the other depleted legions.

**119.** **CHAP. 2.** In the details of this chapter, notice the formidable appearance, but the really long, weak and broken line of the Gallic confederacy.

**CHAP. 3. Nerviorum**: the vitality of this tribe is remarkable, after its triple extermination. — **praedâ**, *as booty*; **eâ** (referring to **magno . . . numero**) agrees by attraction with the appositive, § 195. *d*; G. 202. R. 5; H. 445. 4.

2. **ut . . . videretur**: it seems more reasonable to read **ne** instead of **ut**. — **Lutetiam** (translated by Carlyle *Mudtown*): the first mention in history of *Paris*, which was a place of no importance until its occupation as a royal town by the Franks in A.D. 502. The original place of meeting had probably been Samarobriua (*Amiens*).

3. **civitatem conjunxerant**, i.e. with the Senones. This was a close political union, not a mere military league (*foedus*). — **hoc consilio**, the new confederacy (compare Bk. VII. Chap. 75). — **hac re**, the removal to Lutetia. — **pro suggestu**, *in front of the platform*; i.e. by public announcement, not special notification to the commanders.

**CHAP. 4. conantibus** (sc. *iis*, abl. abs.), *while they were attempting* to effect the gathering.

2. **fide**, *protection* (implied by the act of trust), i.e. of the Romans. — **libenter**, &c. But Acco was afterwards put to death; see Chap. 44.

**120.** 3. **equites**: the cavalry of the Roman armies was wholly furnished by the subject-allies.

CHAP. 5. **Cavarinum**, a chief appointed at Cæsar's dictation, and odious to his tribe (Bk. V. Chap. 54). Hence his animosity (*iracundia*) against the State which had driven him into exile. — **meruerat**, implying a harsh and tyrannical rule.

2. **pro explorato** = *ascertained*.

3. **venisse**, understand **eum** (Ambiorix).

4. **haec auxilia**, i.e. both the Menapii and the Germans. — **lacesseret**, subj. of relat. clause following **existimabat**.

CHAP. 6. **tripartito**: in three columns, on different roads.

**121.** CHAP. 7. **viā**, abl. of distance, understanding **quam** (§ 247. c; G. 311. R. 4; H. 417. I. N. 2). — **cum** . . . **cognoscunt**, really the main proposition. See "The Conjunction **Cum**," note on Bk. III. Chap. 9.

2. **a** (adverbial), *away*. — **impedimentis**, i.e. the greater part of the heavy baggage. He took a baggage-train with him (Chap. 8<sup>3</sup>), probably merely what was necessary.

3. **flumen**, probably some stream flowing into the Meuse (*Mosa*), perhaps the Alzette. — **spes**, *their* (the Treveri) *hope*.

4. **palam**, *freely or openly*, but not in set speech. — **castra moturum**, feigning flight (see below Chap. 6, 7).

5. **natura**, their natural attachment to their own land.

CHAP. 8. **cum**: see note on CHAP. 7<sup>1</sup>.

**122.** 3. **imperator**: Cæsar, who alone had the *imperium*, or military authority.

4. **dirigi**, i.e. *to be formed* and aligned; **dirigo** properly has only the latter meaning. There is an ellipsis of **instrui et**.

5. **impetum modo**, *the mere onset*.

6. **recepit**, *recovered* to obedience (compare Bk. V. Chap. 2-5). — **auxilio**, dat. of service.

7. *comitati eos, in company with them* (the Germans). — *demonstravimus*: see Bk. V. Chap. 3 and 56.

CHAP. 9. *miserant*, sc. **Germani**, implied in **trans Rhenum**.

2. *paulum supra, a little above*, or to the south, “apparently near *Andernach*.” — *nota ratione* = *on the plan already tried and approved* (compare Bk. IV. Chap. 17).

**123.** 4. *purgandi sui*, § 298. *a*; G. 429. R. 1; H. 542. I. N. 1.  
6. *cognita, having inquired into*.

CHAP. 10. *iis . . . imperio*, subject tribes, not confederate allies. Tacitus, however (Ger. 38), represents the Suevi as a confederacy: its subjects may, after Cæsar’s time, have been admitted to alliance. — *peditatus*, § 214. *e*; G. 359; H. 396. VI.

3. *penitus, entirely*.

4. *silvam*: this was the natural frontier (*pro nativo muro*) of the north German plain towards the south. A range of wooded hills still borders the Saxon duchies on the north. The Cherusci held the valleys of the *Weser* and *Seine*.

CHAP. 11. *locum*, a “place” where there is really nothing to tell, as Cæsar found the country deserted (Chap. 29), and returned at once to Gaul. We owe to this void in the narrative a most curious and entertaining glimpse into the geographic and ethnographic knowledge of the time.

**124.** 2. *quorum*: the antecedent is *principes*. The subjunctive *redeat* indicates the character of their authority (§ 320; G. 633; H. 503. I.). Or, by making *eorum* the antecedent, we should have the meaning that the party chiefs are designated (as in our political conventions) by a body, or council, to whom the decision is referred by general consent, — a plausible understanding of the passage.

3. *ne quis*, correl. with *ita* (in *itaque*); the clause *ne . . . egeret* being in appos. with *eius rei*, and the past tense (*egeret*) taking its time from *institutum* [esse]: § 287. *a*; G. 518. exc.; H. 495. IV.

4. *ratio, order of things*. — *in summā, in general*, the gen. **Galliae** depending on *ratio*.

CHAP. 12. **cum . . . venit.** See "The Conjunction **Cum**," note on Bk. III. Chap. 9. — **Sequani**, who succeeded to the domination of the *Arverni* (see Bk. I. Chap. 31). — **antiquitus**, really, only a little while before, as the *Ædui* had risen by favor of the Romans. — **jacturis, sacrifices.** — **clientelae, dependents.** These were the petty tribes, which grouped themselves about one or the other rival State.

3. **Divitiacus**: compare the note to Bk. I. Chap. 31<sup>3</sup>. — **infectare, without effecting his object** (Kraner has **imperfecta**).

4. **reliquis rebus**, abl. of instr. with **amplificata**.

5. **adaequare, were equal**, i.e. to the *Ædui*. (The inferior clause depends on **intellegebatur**.)

**125.** CHAP. 13. **plebes** (sing.), perhaps the scattered rural population (?). — **nullo**, either an older form of dative, or (more likely) an experiment in uniformity of Cæsar's own, like **alterae** in Bk. V. Chap. 27, and **paterfamiliae** in Chap. 19, below.

2. **cum . . . premuntur**, indicative to express *repetition*, — a general truth. See "The Conjunction **Cum**," note on Bk. III. Chap. 9. — **quae dominis** (dat. of poss.), *as masters have*.

4. **sacrificiis**, abl. of separation; understand **eos** with **interdicunt**.

5. **decidunt**, sc. **de viâ** (i.e. "cut" them in the street). — **incommodi**, part. gen. following **quid**.

7. **Carnutum**: this central spot was at or near the modern town of *Dreux*, where, it is said, traces of these assemblies may still be found.

**126.** CHAP. 14. 2. **ediscere, to learn by heart**.

3. **fas**: the words **fas** and **nefas** refer to what is *religiously* right and wrong, in distinction from **jus** and **injuria**, which refer to *human* obligations only.

4. **litteris confisos**, *by trusting to written words*, — a useful hint to teachers.

5. **hoc** (acc.; more usually **illud**) refers to what follows; **hoc** (abl.) to what has just been said.

6. **mundi, the universe** (system of things); **terrarum** (cf. **orbis terrarum**), *the world*.

CHAP. 15. **equitum**: these made a sort of military nobility. It is interesting to compare the two "upper classes" here described with the ecclesiastics and feudal *noblesse* of France before the Revolution. — **cum est**: notice the force of the indicative. See "The Conjunction **Cum**," note on Bk. III. Chap. 9. — **versantur**, *engage*, or *are employed*.

2. **ut quisque . . . ita**, *the more . . . the more* (§ 93. *c*, at end; G. 645. R. 2; H. 458. 2). — **ambactos**: this Celtic word was known as the equivalent of **servus**, "slave," as early as the time of Ennius, 150 years before (compare Chap. 13<sup>2</sup>).

CHAP. 16. **homines immolant**: the practice of human sacrifice is thought (by Thierry) to have been obsolete at this time in Gaul. Cæsar appears not to have known any actual instances of it.

127. 3. **supplicia**, i.e. as sacrifices. The word ("downbent") refers to the attitude of the victim, who is bound and kneeling to receive his doom. The choice of criminals for this purpose may remind us of that latest form of human sacrifice, the punishment of death for heresy. — **defecit**: § 279. *b*; G. 228. R. 2; H. 471. II. 3. See "The Conjunction **Cum**," note on Bk. III. Chap. 9.

CHAP. 17. **Mercurium**: the name of the god whom the Romans identified with Mercury is lost (*Teutates?*); but it appears from inscriptions and images that his worship was very widespread and important throughout the period of the Empire. The other deities here mentioned appear under numerous epithets. Jupiter was probably the Gallic *Taranis*, whose name appears to indicate that he was a god of thunder. He has been identified by some with a statuette bearing in its hand a long hammer or mallet, like the Scandinavian *Thor*. (*Esquisse de la Religion de Gaulois*, by Henri Gadioz.)

3. **cum**, &c. See last note on Chap. 15. — **ceperint**. subj. *o* characteristic.

5. **capta**, *taken as spoil*; **posita**, *consecrated as a gift*.

CHAP. 18. **Dite** = *Pluto*, the god of Darkness, or the Under-world (see § 244. *a*. R.; G. 395; H. 415. II. N.). — **ob**, translate *in keeping with*, as it cannot be the true reason, — the fact being

common to most primitive peoples: e.g. the Germans (Tac. Germ. 11). Our word "fortnight" is a relic of this early use. — **ut . . . subsequatur**, i.e. the day began at sunset.

2. **fere ab reliquis**, *from most others*. — **suos liberos**, &c. The Romans, on the other hand, accustomed their sons to public life, and in early times even took them with them into the Senate. — **cum**, &c. See last note on Chap. 15.

**128. CHAP. 19. quantas . . . communicant**: the husband deposits, in a common fund, an amount equal to the wife's marriage-portion.

2. **ratio habetur**, *a reckoning is kept*. — **fructus**, *revenues*, or *profits*.

3. **vir in uxores**, &c.: compare the Roman *patria potestas*; the rank of the wife was much higher among the Germans. — **cum**, &c. See last note on Chap. 15. — **de uxoribus**: this is thought by some to imply polygamy among the Gauls. — **in servilem modum**, *after the manner of slaves*, i.e. by torture.

4. **pro cultu**, *considering the degree of refinement*: "not up, perhaps, to the Roman ideas as to gladiators and the like" (Moberly). — **hanc = nostram** (cf. Bk. II. Chap. 4<sup>b</sup>). — **justis**, *right*, by conventional rule. When these had been fulfilled, the sacrifice was added.

CHAP. 20. **legibus sanctum**, *established by law*, agreeing with the clause **si . . . communicet** (obj. of **habent**). — **quo**, *indef., any one (nequis)*.

2. **quod saepe**, &c. Compare the lively account in Bk. IV. Chap. 5.

3. **quae visa sunt**, *what they think fit to conceal* (understand **occultanda**, and compare  $\alpha$   $\delta\omicron\kappa\epsilon\acute{\iota}$   $\alpha\upsilon\tau\omicron\iota\varsigma$ ). — **per concilium**, *by means* (or, *in the proceedings*) of the public assembly.

CHAP. 21. **neque Druides habent**: they had, however, both priests and priestesses, with religious forms public and private. Cæsar's contact with the Germans, it is to be remarked, was only on their unsettled military frontier.

2. **deorum numero**, &c. In this, Cæsar's testimony is directly contradicted by Tacitus, who speaks (Germ. 9) of their worship

of Mercury, Mars and Hercules. This is almost the only contradiction between these writers, in whose accounts of political and other institutions there is a striking agreement.

3. **ab parvulis**, *from childhood* (compare "from a child," 2 Tim. iii. 15).

**129.** 4. **qui . . . permanserunt**, strictly, "who are slowest to outgrow" their boyhood. Compare Tacitus: *sera juvenum venit, eoque inexhausta pubertas*; and contrast the premature debaucheries of the Roman youth.

5. **nulla occultatio**, like the English *there is no hiding*. — **rhennonum**, i.e. *reindeer's hide*. — **magnā . . . nudā** (abl. abs.), i.e. in battle, where Cæsar would chiefly meet them.

CHAP. 22. **agriculturæ**: as to this chapter, compare what is said in the general Introduction to the volume, and in Bk. IV. Chap. 1, where it is shown that the soil was tilled, not by the labor of old men, women, or slaves, but by that of the fighting men. In other words, the Germans were, though "barbarians," not (in one sense) a barbarous people.

2. **neque quisquam**, &c. This temporary and shifting occupation of land, as well as the holding of it by the family or clan (*cognationibus*), is characteristic of a primitive society. But compare the Introduction, as above. — **fines proprios**, *private boundaries*, or *landmarks*. — **qui unā coierunt**: in the general gathering for this assignment, each clan must have met by itself, and been represented by its chief.

3. **agriculturā**: notice the use of the ablative (§ 252; G. 404; H. 422. N. 2), here to be rendered "for." — **ne . . . expellant**: this was a flagrant evil in Italy, which Cæsar had attempted in his own consulship to check (by the *lex agraria*), following the precedent of the Gracchi. There the *potentiores* had already succeeded in ousting the *humiliores* from their estates, and creating enormous plantations, *latifundia*, cultivated by slaves, in place of the earlier peasant freeholds. — **cum . . . videat**: this looks as if the land was portioned in equal shares to rich and poor alike, unless we take **aequari** in the sense of a *conative present*, implying only tendency, or opportunity.

CHAP. 23. **maxima laus**: so in Bk. IV. Chap. 3. — **virtutis**, § 218. *d*; G. 356. R. 1; H. 391. II. 4. — **prope**, *near*; **consistere**, *to stay or settle*; observe the reduplicated form, with the force given by **con**.

2. **cum . . . infert**: note force of pres. indic. with **cum**. See "The Conjunction **Cum**, note on Bk. III. Chap. 9. — **magistratus . . . deliguntur**, by lot, according to the Saxon Bede, from among existing magistrates. The Goths, Burgundians, Franks and Lombards, on the other hand, had real kings.

3. **principes . . . pagorum**; these local and village chiefs, forming a sort of governing body, were probably the "natural leaders" each of his own district. They are said, however, to have been elected, no doubt for life, by an assembly of the tribe or nation (Tac. Germ. 12).

4. **latrocinia . . . extra fines**, "cattle-lifting raids," like those of the Scottish Borderers.

130. 5. **ubi quis** (indef.), &c. This is how volunteers were mustered for the raids in question. — **omnium rerum fides**, *confidence in anything*.

CHAP. 24. **cum . . . superarent**: a clause of characteristic.

2. **Hercyniam silvam**, the great wooded range extending from the Black Forest to the Bohemian Highlands. — **Volcae**, &c., occupying the southern part of Gaul, about *Narbonne* or *Toulouse*. A portion, only, had migrated to Germany; or, as some hold, had staid behind from an early Celtic migration westward.

CHAP. 25. **expedito** (dat.), "with free foot," i.e. unencumbered with baggage. — **non noverunt**: so at the present day, in the mountain regions of Germany and Switzerland, distance is measured by "hours" (*stunden*) instead of miles.

2. **Nemetum**, &c., along the middle course of the Rhine, where it flows northward from Bâle. — **recta . . . regione**, i.e. parallel. — **Dacorum**, &c., occupying the eastern and western portions of Hungary. — **sinistrorsus**: in reality, it is the river which leaves the course of the forest or highland, bending abruptly to the right, or southward. The ancients had no compasses, and were careless observers of direction (compare Bk. V. Chap. 13).



3. **hujus**, that familiar to the Romans, viz. *western*. — **initium**, as we should say *the end*, eastward, where it is lost in the Carpathian range. Its extent, in a direct line, is stated as 1600 miles. — **pro-cesserit, acceperit**: subj. by indir. disc. for perf. indic. See last note on Chap. 15.

**131. CHAP. 26. bos**: this name seems to have been given loosely to any large-horned, unfamiliar beast, even to the elephant; here it is probably the *reindeer*, which had anciently a wide-scattered range. — **unum cornu**: perhaps the specimen described had lost a horn; or, more likely, the expression refers to the long projection from which both branches spring, instead of growing independently, like the horns of an ox. The description of the horn might, however, rather suggest the moose or Irish elk.

2. **palmae ramique** (hend.), *branching antlers*.

**CHAP. 27. alces**: this name is undoubtedly *elks*, but the description is widely unlike ("a little bigger than goats!") and quite unrecognizable. If it were correct, the creature would be well entitled to the name "wretched animal" (*elendthier*) bestowed upon it in German. — **crura . . . habent**: the same yarn is told by Pliny, H. N. viii. 16, 39.

3. **cum**. See last note on Chap. 15. — **subruunt, undermine**; **accidunt, cut into**. — **summa species, the surface look**.

4. **cum**. See above.

**CHAP. 28. uri**: this name is generally understood to refer to the German *Urochs* (the primitive or wild ox, probably *buffalo*), said still to be found in the forests of Lithuania.\* Cæsar evidently describes a very different animal, with great spreading horns like those of a reindeer or moose; but the whole description must have been derived from a confused account.

4. **ne . . . excepti, not even when caught quite young**.

**132. 5. ab labris, around the rim**.

\* The buffalo of Eastern Europe, domesticated in Transylvania, where the cows are valued for their milk, is long and rather low in form, with depressed and flat horns, like those of the musk-ox. — J. H. A.

CHAP. 29. **Caesar, &c.** This chapter directly follows Chap. 10, the intervening passage being a digression.

2. **barbaris**, dat. (§ 229; G. 344. R. 2; H. 385. II. 2). — **ne . . . tolleret**, as would be done by completely destroying the bridge; **ut tardaret**, by making it practically useless. — **in extremo ponte**. There seems to have been an island in the river at this place, so that the bridge was in two sections. The section between the island and the right bank was destroyed, and at what was now the end of the bridge (**extremo**), on the island, the tower was built. There was probably a redoubt, as usual, at the entrance to the bridge on the mainland. — **cohortium duodecim**: these were auxiliaries, as it appears in Chap. 33 that he had all his legions with him.

3. **maturescere**, i.e. early in August. — **Arduennam**, the modern *Ardennes* (Shakspeare's *Forest of Arden*). — **quingentis**: an obvious mistake, possibly of some copyist. It should be **centum et quinquaginta**.

4. **si quid . . . possit** (interrog. § 334. *f*; G. 462. 2; H. 529. I. N. 1), *to see whether, &c.* — **subsequi** (pres.), i.e. *is already on the road*.

CHAP. 30. 2. **multum potest**, *has great power*. It has been observed that Cæsar, since his failure in Britain, harps much on the favor of Fortune (compare Chaps. 35, 42), and seems to waver in his confidence in Destiny. — **ipsum** (twice), referring to Ambiorix. — **prius . . . quam**, render as one word, *before*, — English omitting the relative particle. — **magnæ fortunæ** (pred. gen.), *a great piece of luck; or, mere luck*.

133. 3. **hoc**, abl. of means, explained by **quod . . . sustinerunt**. — **sunt fere**, *generally are*.

4. **his pugnantibus**: notice the force of the Latin order. *While these were fighting*, time was given for the chief to be placed on horseback by some of his followers, and, *as soon as he actually got away*, he was covered by the woods.

CHAP. 31. **judicione . . . an**, *whether by design . . . or, &c.* — **existimarit, crederet**: in direct discourse, **existimavit** (an act of decision) and **credebat** (a state of opinion).

2. *quas aestus*, i.e. islands only at high tide. — *alienissimis, entire strangers.*

3. *precibus detestatus*, *cursing with formal imprecations*, which, from a dying man, were thought to have efficacy with the gods.

CHAP. 32. *unam esse causam*, *that the case was the same*, i.e. that they were all included in the league.

2. *convenissent, reducerentur*, in dir. disc. *convenerint, educantur.*

**134.** 3. *id castelli nomen est*, *that is the (German) name of (for) a stronghold.* It will be remembered that the *Aduatuci* were of German descent; and it is thought that *Aduatuca* is an old German word, meaning *a stronghold*. Then the *Aduatuci* were the people who held such a place of safety. There were several towns of this name, which fact adds force to the conjecture. — **Titurius**, &c. (Sabinus and Cotta). See Bk. V. Chap. 24.

6. **Q. Ciceronem**: this post was forced upon him "to keep him from the ranks of the republican opposition at Rome," of which he was afterwards an obstinate adherent. He was at this time a *legatus* of Pompey.

CHAP. 33. *ad . . . versus*, *towards*. — **Scaldem**, *the Scheldt*. There seems to be some confused geography here.

2. *post diem septimum*, *the seventh day after*. — *quam ad diem*, compare Chap. 35 (*quem ad diem*).

3. *commodo* (abl.), *to* (in accordance with) *the advantage* (*reipublicae* is gen.).

CHAP. 34. *supra*, in Chap. 31. — *quod se defenderet*, *capable of*, &c. (subj. of characteristic).

2. *cuique*, *to any*. We should put the distributive with the leading verb (*consederat*), *each had taken position where*, &c.

3. *universis*, *to men gathered in one body*. — *ex parte*, *in a measure*.

**135.** 5. *hominum sceleratorum*, *those scoundrels*; an expression of temper which Cæsar does not often permit himself towards his foes, whose crime was (says Kraner) "that they dared to maintain their independence." — *ad signa* = *in camp*.

6. *noceretur*, *harm should be done* to the enemy, through the animosities of their own countrymen. — *uloiscendum*, *to avenge* the destruction of the force of Sabinus and Cotta (Bk. V. Chaps. 27-38).

CHAP. 35. 2. *possit, adferat*: present tense to express a general truth; though usually in Latin such expressions follow the sequence of tenses.

3. *ultro, freely*, i.e. any that would; as a general invitation, extending beyond those immediately concerned.

4. *supra docuimus*, see Bk. IV. Chap. 16.

5. *primos fines, the nearest limits*.

136. 7. *fortunatissimis*: § 272. a; G. 535. R. 2; H. 536. 2. 3). — *Aduatucam*, see Chap. 32<sup>d</sup>. — *tantum, only so much*, really, *so scanty*. — *cingi, surrounded* (with a line of defenders).

8. *duce, as guide* (pred. appos.).

CHAP. 36. Cicero. See Chap. 32<sup>b</sup>, with note. — *continuisset* (concessive subj.), *while he had, &c.* — *de, &c.*, construe with *fidem*.

2. *illius, &c., who called his quiet waiting a blockade*. — *siquidem, since*: with subj., indicating the ground of their complaint. — *quo* (following *ejusmodi, of such sort that*), with *posset* as subj. of result. — *offendi* (impers.), *an attack could be made*.

3. *hoc spatio, since Cæsar's departure*. — *sub vexillo*: the *vexillum* was a little scarlet flag (quite distinct from the metal *signum*), used by small bodies detached for some special service. The name *vexillarii* was given to the soldiers of such a corps. See note on Bk. I. Chap. 25. — *jumentorum*, to bring in the expected supplies. — *subsederant, had stayed behind* when Cæsar left. — *facta potestate, obtaining leave*.

CHAP. 37. *ab decumana porta, at the rear gate* (see Fig. 15). The camp fronted in the direction where the enemy were supposed to be — i.e. the Gallic tribes; so that its more exposed part lay nearest the German attack. — *neu prius . . . quam, not till*. *silvis*: it was considered bad management to place a camp so near the woods as to conceal the approach of the enemy. The pickets, too, must have been either very carelessly stationed, or very negligent. — *usque eo, so close*. — *qui . . . mercatores, the traders*

(sutlers) *who spread* their booths (*tentoria*) *under the shelter of the wall.*

**137.** 2. *circumfunduntur* (the middle or reflexive use of the passive, rendered in English by the active form), *pour on*, or *about*.

3. *reliquos aditus*, *any other way of approach*. — *quisque conveniat*, *each soldier* (= all the soldiers) *shall get together* for defence. — *provident*: the plural here seems to imply that they were without a commander, — a grave military fault.

4. *imperatore*, *Cæsar*. Observe the force of *atque*: *and the general too!* — *novas religiones*, *a sudden superstition*, as if the spot itself were unlucky to the Romans (see Chap. 32<sup>3</sup>). — *qui occiderint*, *who* (as they recalled; hence subj.) *fell*.

CHAP. 38. *ad Caesarem*, *at Cæsar's side*. — *proeliis* (loc. abl.), see Bk. II. Chap. 25; Bk. III. Chap. 5.

2. *consequuntur hunc*: as *primus pilus*, he had authority to command all other centurions; although generally, as here, he really only formed a rallying point. See note on Bk. I. Chap. 7.

3. *relinquit animus*, *breath* (or consciousness) *fails him* (he faints). — *per manus tractus*, *dragged along from hand to hand* by his comrades.

CHAP. 39. 2. *hic*, in the open field. — *modo . . . exspectant*: the Roman discipline was so perfect that, in general, every man knew just what to do in any emergency (as in the fight with the Nervii, Bk. II. Chap. 21); but these new levies are helpless till the exact order has been given, even the boldest of them (*nemo est tam fortis*, &c.).

**138.** 3. *legiones*: those of Trebonius, which had been sent to lay waste the territory (Chap. 33<sup>1</sup>).

CHAP. 40. *in signa manipulosque*, *among the cohorts and maniples*. In their panic the servants not only rushed through the intervals between the cohorts (*signa*), but many of them also poured through the narrower spaces between the maniples. — *alii . . . alii*: these were the men in the ranks, who seem to have had time for cool deliberation, as is implied in the expression *censent*, the regular expression for voting in a public assembly.

3. **hoc**: the latter counsel, which was that of the raw recruits. — **docuimus**, Chap. 36<sup>3</sup>. — **C. Trebonio**: compare Chap. 33<sup>1</sup>; his relation to Q. Cicero in this command is not quite clear.

4. **militum virtute**: i.e. of the infantry; the cavalry, it will be remembered, were not Roman, but Gallic allies. — **nullo usu percepto**, *having gained no experience*. — **eo consilio**, in appos. with **ut . . . defenderent**. — **demiserunt**: **se** has already been expressed with **recipere**.

5. **ex inferioribus ordinibus**: the officers of a new legion were usually obtained in this way, being promoted from the lower grades of veteran cohorts. See note on Bk. I. Chap. 40, "Relative Rank of the Centurions."

CHAP. 41. **constitisse**, &c., *had now gained position within the works*.

2. **fidem non faceret**, *did not gain belief*.

139. 3. **alienata mente**, *beside themselves* with terror. — **deletis . . . recepisse**, obj. of **dicerent**. — **incolumi exercitu** (abl. abs. denoting condition), *in case the army were safe*. — **oppugnatos fuisse**, the regular form in indir. disc. for *oppugnassent*.

"Where Q. Cicero was all this time, we are not informed. He probably lost his head with the rest, but Cæsar passes it over in silence, probably in consideration for his brother." — *Kraner*.

"Brave as they were, the Roman soldiers seem to have been curiously liable to panics of this kind. The faith with which they relied upon their general avenged itself through the completeness with which they were accustomed to depend upon him. He returned on the day which he had fixed, and not unnaturally was displeased at the disregard of his orders. He did not, or does not in his Commentaries, professedly blame Cicero. But the Ciceros perhaps resented the loss of confidence which one of them had brought upon himself. Quintus Cicero cooled in his zeal, and afterwards amused the leisure of his winter quarters with composing worthless dramas." — *Froude's "Cæsar."*

CHAP. 42. **eventus** (acc. plur.) **belli** *the fortune of war* (in general). — **unum**, *only one thing*. — **minimo**, *in the slightest degree*; **casu** is to be rendered as dat. with **relinqui**. — **avertisset**, sc. **fortuna**.

2. **videbatur**: the subj. is **quod . . . obtulerunt**. — **Ambiorigi**: this object of Cæsar's special animosity and eager pursuit was never captured.

CHAP. 43. 3. **in eum locum** = *so close upon him*. — **ut . . . contenderent**, *that prisoners who were brought in looked round among themselves for Ambiorix, whom they had just seen in flight* — supposing that he must have been taken also — *and insisted that he was not yet quite out of sight*. — **paene . . . vincerent**, *almost surpassed the bounds of nature in their eagerness*. — **summam felicitatem**, i.e. the prize offered for his capture.

CHAP. 44. **more majorum**: the ancient Roman mode of punishment was to fasten the head in a sort of stocks or pillory (*furca*), then flog the person to death, after which he was beheaded. It was an extraordinary sentence to pronounce on a prisoner of war. Concerted resistance (*conjuratio*) had come to be regarded as a flagrant crime, and its penalty was more and more bloody as time went on — as we see in the two succeeding Books (see especially Bk. VIII. Chaps. 39-44).

2. **aqua . . . interdixisset**, i.e. *banished them*, forbade them to return to Gaul.

THE LEGIONS. — At the opening of the campaign of 53 B.C., Pompey loaned Cæsar two legions (I and III). One new one was raised, which received the same number (XIV) as the one Cæsar had divided (see note on "The Legions," end of Bk. V.), and of which five cohorts were lost with Sabinus. Hence the number of legions in Gaul had now reached ten.

## BOOK SEVENTH. — B.C. 52.

WAR OF VERCINGETORIX. — The last three campaigns had been conducted wholly in the north, with a view either to crush the bolder and more restless northern populations, or to overawe the more barbarous Britons and Germans beyond the frontier. It is not quite clear why the discontented spirits of the south did not seize the occasion to join forces with the formidable Belgian revolt. At all events, they seemed quiet and submissive after their defeats in the earlier campaigns, and might have continued so but for the news from Rome, where "the discomfiture of Crassus had been more pleasant news to the Senate than the defeat of Ariovistus; and the passionate hope of the aristocracy had been for some opportunity which would enable them to check Cæsar in his career of conquest, and bring him home to dishonor and perhaps impeachment." — *Froude*.

This opportunity might seem to offer in the disorders which followed the death of Clodius. Clodius was a bully and professional politician belonging to the popular party, a bitter enemy of Cicero, whom he had succeeded, a few years before, in driving into exile. He was killed in a street brawl on the 20th of January of this year by Milo, a ruffian of the senatorial or aristocratic party. For the time, all regular and orderly government was at an end, till at length Pompey was invested with dictatorial powers, and quiet was restored. The news of these events coming to Gaul, gave the native leaders reasonable ground to hope that a new uprising might be successful. Their plan, it will appear, was, by a sudden movement, to cut off Cæsar's communications with his military posts in the north, which would thus be speedily starved into surrender. This plan Cæsar foiled by striking, with his usual rapidity, through their line, and through the neutral or hostile populations of Central Gaul, and so advancing upon his assailants with the support of his legions from the north. His campaign of this year was the most fiercely contested, as well as the most important and decisive, of the entire war.

CHAP. I. **Quieta Gallia**: compare Bk. II. Chap. 35; Bk. III. Chap. 28. — **ut . . . conjurarent** (clause depending on *senatus consulto*): this was not an ordinary conscription, but a levy *in mass*, in which the entire population of Italy liable to military duty (the



*juniores*, between 17 and 46) took the oath of service. In addition, Cæsar orders a levy throughout his own province (*totā provinciā*), in which were included *Gallia Cisalpina*, *Gallia Transalpina* and *Illyricum*.

2. **quod . . . videbatur**: it naturally seemed to them impossible for Cæsar to quit Italy at this crisis (**urbano motu**).

**142.** 4. **Acconis**, see Bk. VI. Chap. 44.

5. **ut . . . intercludatur** (see introductory note) depends on **rationem**, *the plan of campaign*.

CHAP. 2. **Carnutes**: this name is represented by *Chartres*, S.W. of Paris. — **principes ex omnibus** = *first of all*.

2. **ne res efferatur**, as the exchange of hostages would be a notorious and public act.

CHAP. 3. **Genabum** (or **Cenabum**), now *Orleans*, on the Loire. — **negotiandi**: their business was "money-lending (unrestrained by Roman usury-laws), the farming of taxes, purchase of slaves or corn, and the like." Cicero had said, some years before, that business affairs in Gaul were wholly controlled by Roman citizens. — **constiterant**, *had settled*.

2. **clamore**, a sort of vocal telegraph, by which, as also by signal-fires, messages were conveyed "from towers 500 yards apart."

**143.** 3. **ante . . . vigiliam**, between 9 and 10 at night; the message thus occupying about sixteen hours, being carried by foot-runners from post to post. — **Arvernorum**, i.e. *Auvergne*, a region always noted for the vigor and hardihood of its population, who now became leaders in the great revolt, and furnished its dauntless chief Vercingetorix. It is noticeable that the present uprising was confined to western central Gaul, and did not include either the Aquitani or Armorici, who had both been too thoroughly subdued.

CHAP. 4. **Vercingetorix**, a name or title explained as meaning "very brave lord," and well calculated (says the historian Florus) to inspire terror. — **principatum**, &c. See Bk. I. Chap. 31<sup>8</sup>. — **Galliae totius**, i.e. all Celtic Gaul.

2. **prohibetur**, conative present. This discouragement of the elders was of evil omen to his enterprise from the start. — **Gergovia**

the chief town of the Arverni, on an eminence near *Clermont*.—**perditorum**, men of *ruined fortunes*, desperate.

3. **Senones**, &c. Several of these names are preserved in the modern *Sens*, *Paris*, *Poitiers*, *Tours*, *Limoges*. The league included all Celtic Gaul south of the Seine and west of the loyal (or doubtful) *Ædui* and *Bituriges*, who were drawn into it later on.

6. **quod** (interrogative) agrees with **tempus**, and before *what time*.

CHAP. 5. **Rutenos**: these, as well as the *Cadurci*, lay between the Arverni and the Roman province. It was important, therefore, to secure them as a frontier defence.

#### 144. 2. **de consilio**, at the advice.

3. **qui** agrees with the persons implied in **equitatus peditatusque**, § 182; G. 202. R. 1; H. 445. 5.—**veritos**: causal.

4. **quod** (adv. acc.) *because* (the reason for **non videtur**, &c.).—**junguntur** (reflex.), *join*.

CHAP. 6. **virtute** = *vigor*.

2. **qua** . . . **posset**, indir. question following **difficultate**.

3. **nam si**, &c. See the introductory note, above.

CHAP. 7. **Nitiobriges et Gabalos**: these completed the Arvernian frontier, the *Volcae* and *Helvii* being within the limits of the Province.—**Narbonem**, *Narbonne*, the chief town of *Gallia Narbonensis*, founded by C. Gracchus.

2. **antevertendum** [**esse**] has for its subject **ut** . . . **proficeretur**, and is followed by the dat. **consiliis**.

3. **provincialibus**: a portion of the *Ruteni* had been incorporated in the Province.

#### 145. CHAP. 8. **quod** . . . **putabat**, referring to *Lucterius*.

2. **durissimo**, &c. Pompey was put in authority Feb. 25; *Cæsar*, who left Italy directly after, probably crossed the *Cevennes* early in March.—**summo sudore**: "these admirable soldiers were worthy of the genius of their chief."

3. **singulari homini**, "a solitary wayfarer."

CHAP. 9. **usu** . . . **praeceperat**, *had suspected would come to pass*.—**per causam**, *on the pretext* (so elsewhere in *Cæsar*): his

real motive was to join his force. — **Brutum**, Decimus Junius Brutus, afterward one of Cæsar's assassins.

2. **Viennam**, *Vienne*, a little below Lyons on the Rhone.

3. **de sua salute**, *affecting his own safety*.

5. **Gorgobinam**: this was situated probably on the *Allier*, a southern confluent of the Loire. — **quos**, &c.; see Bk. I. Chap. 28<sup>4</sup>.

**146.** CHAP. 10. **stipendiariis**, the Boii, who were in the pay of the Ædui. — **amicis**, &c., *since his friends would find there was no help for them in him*. — **ab**, *in respect to* his supply of corn.

4. **Agedici**, now *Sens*, the chief town of the Senones. It is often written *Agenticum*, or *Agedincum*.

CHAP. 11. **altero die**, *on the second day* of the march. — **circumvallavit**: the circumvallation (properly speaking this was a *contravallation*) consisted of a line of wall and trench surrounding the town.

2. **Genabum**, *Gien*, a little above Orleans, on the Loire. — **quod mitterent**, *to send*.

3. **continebat**, *was close to*. The town being on the north bank, the bridge would admit its defenders to the friendly Bituriges.

**147.** 6. **diripit**: compare the fate of Avaricum, Chap. 28.

CHAP. 12. **ille**, Cæsar.

2. **qua**, *whereby*, referring to **celeritate**.

5. **omnes incolumes** (acc.): see line 16, above; constr. with **repperunt**, *got them all back safe* to Cæsar's camp.

CHAP. 13. **Germanos**: for the training and efficiency of the German horse, see Bk. I. Chap. 48; also Chaps. 70, 80, below.

2. **quibus**, *and these* (the Gallic horse). — **eos**, i.e. the leaders in the sudden movement described above, Chap. 12<sup>4</sup>.

3. **Avaricum**, the modern *Bourges*, an important town of 40,000 inhabitants, the geographical centre of France.

**148.** CHAP. 14. 2. **longa alia ratione atque**, *in a way quite different from*, &c.; by purely defensive or guerilla war. — **anni tempore**, the early spring, long before harvest; all supplies must be got from granaries or storehouses (**aedificia**) which might easily be destroyed.

3. *incendi*: compare the course of the Helvetians, Bk. I. Chap. 5. — *hoc spatium*, the range of the Roman foraging parties. — *quoque versus*, in every direction.

4. *neque interesse*, and it made no difference. — *-ne . . . -ne*, whether . . . or.

5. *sint receptacula*, serve as retreats; *proposita*, offered as spoil.

6. *aestimare*, understand *se*.

CHAP. 15. *urbes*: *Cæsar* more commonly calls them *oppida*. Rome alone is always *urbs*.

2. *amissa* = all they had lost (obj. of *recuperaturos*). — *explorata* (compare Bk. III. Chap. 18; Bk. V. Chap. 43) = *sure*, i.e. to which the way is clearly seen.

4. *flumine*: the city was just above the junction of the *Auron* with the *Yèvre* (see Plan VIII.).

149. CHAP. 16. *longe* = distant.

2. *certos (cerno)*, appointed. — *in . . . tempora*, from hour to hour.

3. *necessario* (adv.), unavoidably. — *ratione*, skilful planning (explained by *ut . . . iretur*, a clause of result).

CHAP. 17. *quae . . . habebat*, i.e. the neck of the peninsula on which the town was situated (Chap. 15<sup>4</sup>). — *intermissa*, left free. — *aggerem*, &c. See note on Bk. II. Chap. 12.

Between the *Yèvre* and the *Auron* was a plateau, some 1200 to 1600 ft. high, with rather steep banks. As this plateau approached the town, it narrowed to a ridge only about 400 ft. wide, with the *Auron* on one side, and a swampy brook, the *Yèvre*, on the other. From the *Yèvre* to the *Yèvre* extended a morass. At a distance of about 300 ft. from the city wall the ridge was intersected by a sudden depression like a trench, perhaps 50 ft. deep (see Plan VIII. 4). *Cæsar* pitched his camp on the plateau just back of the ridge, a little over half a mile from *Avaricum*. Along the ridge, right across the intersecting ravine, he built the *agger*.

2. *alteri*, the *Ædui*, already wavering in their allegiance: *alteri*, the *Boii*, a fragment of the defeated Helvetians (Bk. I. Chap. 28).

3. *caruerint, sustentarent*: notice the change of tense, — the

lack of corn was incidental or occasional: hunger the constant condition.

150. CHAP. 18. qui . . . consuessent see Bk. I. Chap. 46.

4. sarcinas . . . conferri the change from marching to fighting order.

CHAP. 19. difficilis, *hard to cross*; impedita, *entangled with brushwood, &c.*

2. vada, saltus, *fords and open spaces, where the way seemed practicable.* — haesitantes, *struggling in the mud or bushes, obj. of premerent (which is apod. of a future condition), would crush.*

3. prope, *sc.*, *on nearly equal terms*; iniquitatem, *unfair advantage, showing that their offering battle was inanis simulatio.*

4. quod . . . possent follows indignantes, *chafing that, &c.*

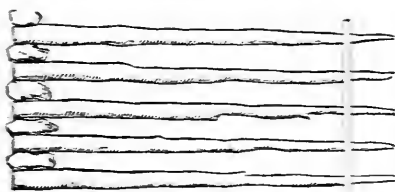

Fig. 40. Ground Plan of Gallic Wall.

151. CHAP. 20. discessisset and venissent refer to the action in Chap. 18.

2. qui se . . . defenderet, *which was its own defence.*

3. mollitiem, *unsteadiness or impatience.* — laborem, *hardship.*

4. fortunae (dat.), as well as huic (referring to alicuius), take with gratiam habendam, *thanks were due.*

5. imperium, the same as regnum Galliae, above. — remittere is *ready to resign*: in direct disc., remitto, *I resign.*

152. 7. si = *to see if.* — posse, sc. quemquam.

8. quem, construe with ne . . . recipiat, subj. of provisum est.

CHAP. 21. suo more: compare Tacitus, Germ. II. *franceses consuetudin.* — summum: this word is often used where we should say "a great."

2. si . . . retinuissent, in appos. with eo.

CHAP. 22. *occurrerant*, worked against, or frustrated. — *atque . . . aptissimum*, compare Bk. IV. Chap. 5.

2. *laqueis*, &c. See Fig. 16. — *cuniculis*, by mines (“rabbit-

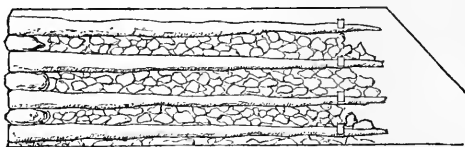

Fig. 41. Vertical Section of Gallic Wall.

burrows”). — *ferrariae*: so of the copper-mines of the Aquitani, Bk. III. Chap. 21<sup>3</sup>.

4. *commissis malis*, by fastening posts: these were the high corner-beams of the towers, by which they were raised in successive stages, so that each increase in the height of the Roman works

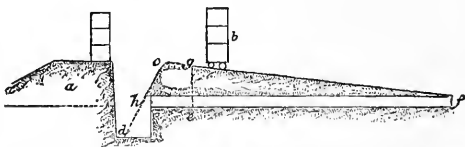

Fig. 42. Section of Roman Agger at Avaricum, according to Göler.

a. City wall. b. Turris. c d e f. Agger. c d e g. Quotidianus agger.  
f h. Covered gallery through the agger.

was met by a corresponding increase in the height of the defences. The towers on the walls were probably connected by covered galleries, one for each story.

153. CHAP. 23. *directae*, at right angles with the course of the wall; *perpetuae*, &c., the whole length. — *revinciuntur*, are fastened by beams some 40 ft. in length, running lengthwise of the wall, to steady the entire work (section 3).

2. *neque . . . contineantur*: so alternating, in the successive layers, that beams rested on stone, and stone on beams.

3. *deforme, irregular or ill-looking*.

CHAP. 24. *latum*: as a width of over 300 ft. is incredible, some

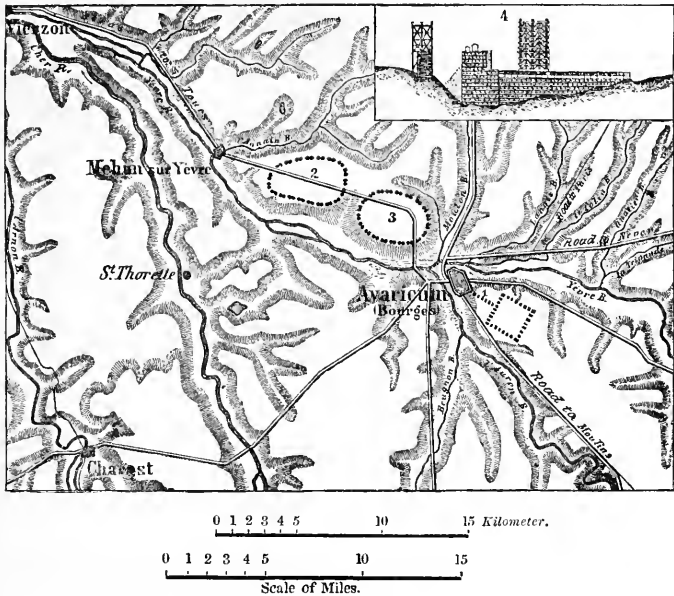

Plan VIII. *Siege of Avaricum.* Bk. VII. Chaps. 23-28.

1 *agger*, pushed towards the town from the Roman camp. 2. First position of Vercingetorix. 3. Second position of Vercingetorix. 4. Section of the *agger*, according to Rüstow.

have supposed that this is an error for *longum*; others, that the numeral should be *xxxx*.

2. *turrium*, the Roman towers, mounted on wheels or rollers, and here placed *on* the *agger* (see note on Bk. II. Chap. 11, "The Siege," 5).— *altum pedes LXXX*: it must be remembered that

the height of the *agger* had to equal the depth of the ravine it crossed, and also the height of the Gallic wall. The latter may have been 30 ft. Göler supposes that the *agger* sloped gradually up towards the enemy (see Fig. 42). But the construction of Rüstow and Napoleon III. (Plan VIII. 4) seems simpler.

**154.** 4. *partitis temporibus*, i.e. *in their turn*. — *interscindere*, i.e. they cut away the unfinished end of the *agger*, which was in flames. Thus the rest was saved.

CHAP. 25. *pluteos*, see Figs. 20–22. — *nec . . . animadvertibat* = *and noticed that relief did not easily arrive, exposed* as the men were by the burning of the defence.

2. *scorpione*: this was a powerful cross-bow, for hurling darts or “bolts.” (See Fig. 18.)

CHAP. 26. 3. *quos* refers to *se* as well as to *liberos*.

**155.** 4. *non recipit*, *does not admit*.

CHAP. 27. *suosque*: the *que* connects *arbitratus est* with *jussit* and *ostendit* (notice the tense).

2. *intra vineas*: it would be impossible for *legions* to find room *inside* the *vineae* (see note on Bk. II. Chap. 12). Either *legiones* here refers to the storming columns, or *intra vineas* means *among* and *around* the sheds. — *expeditis*, *put in fighting order* (see Chap. 18<sup>4</sup>).

CHAP. 28. *cuneatim*, *in compact body* (“wedge-fashion”), implying excellent discipline.

2. *circumfundi* (impers. pass.) = *that men were pouring on*. — *continenti impetu*, *in one mass*.

4. *quae pars* refers to those implied by *suos*, and is explained by Chap. 19<sup>2</sup>, where it is said that the Gallic forces were arranged *generatim*.

**156.** CHAP. 29. 2. *errare si qui* = *that those were wrong who*, &c.

3. *Biturigum*: see Chap. 15<sup>4</sup>. — *obsequentia*, *yielding*, or *deference*.



4. **effectum habere**, see note on Bk. I. Chap. XV., **coactum habebat**.

5. **impetrari**: notice the modesty of this phrase, appropriate to the great disaster just suffered.

CHAP. 30. **re integra**, while his force was still unbroken (Chap. 15<sup>3</sup>).

3. **de reliquis**, &c., follows in **spem**. — **homines insueti**, understand “although.”

CHAP. 31. 2. **capere** = *gain over* (“catch”) the neutral states.

**157.** 3. **sagittarios**: apparently the Gauls had trusted too much, in the siege especially, to hand-to-hand fighting.

4. **quos conduxerat**, whom he had hired; i.e. mercenaries.

CHAP. 32. 2. **confecta**: it was now about the end of March, or a little later. — **sive . . . sive**, understand “to try,” or some such phrase.

3. **annum**: see Bk. I. Chap. 15.

4. **proximo anno**, the year before. — **clientelas**, armed followers (Bk. VI. Chap. 15).

5. **positum** [esse], depended on.

**158.** CHAP. 33. **minus** [sibi] **confideret** = *felt itself weakest*.

2. **quos inter** = **eos inter quos**.

3. **renuntiatum**: *renuntiare* is the technical term for the act of a magistrate who, after an election, formally declares the result, and thus “creates” the new official. — **intermissis magistratibus**: this phrase signifies that an interval occurred between the term of one magistrate and the due election of his successor. In such a case at Rome (as had recently occurred twice, B.C. 55 and 52), the patrician senators appointed an *interrex* by virtue of the sacred authority residing in them. Cæsar here, accordingly, recognizes the likeness to a Roman precedent. — **obtinere**, to hold against (ob) the rival claimant. See note on Bk. I. Chap. 1<sup>4</sup>.

CHAP. 34. 2. **secundum flumen**, along the stream (construe with **duxit**).

3. **ab altera parte**: Cæsar being on the right or eastern bank, Vercingetorix on the western, on which the town of Gergovia lay.

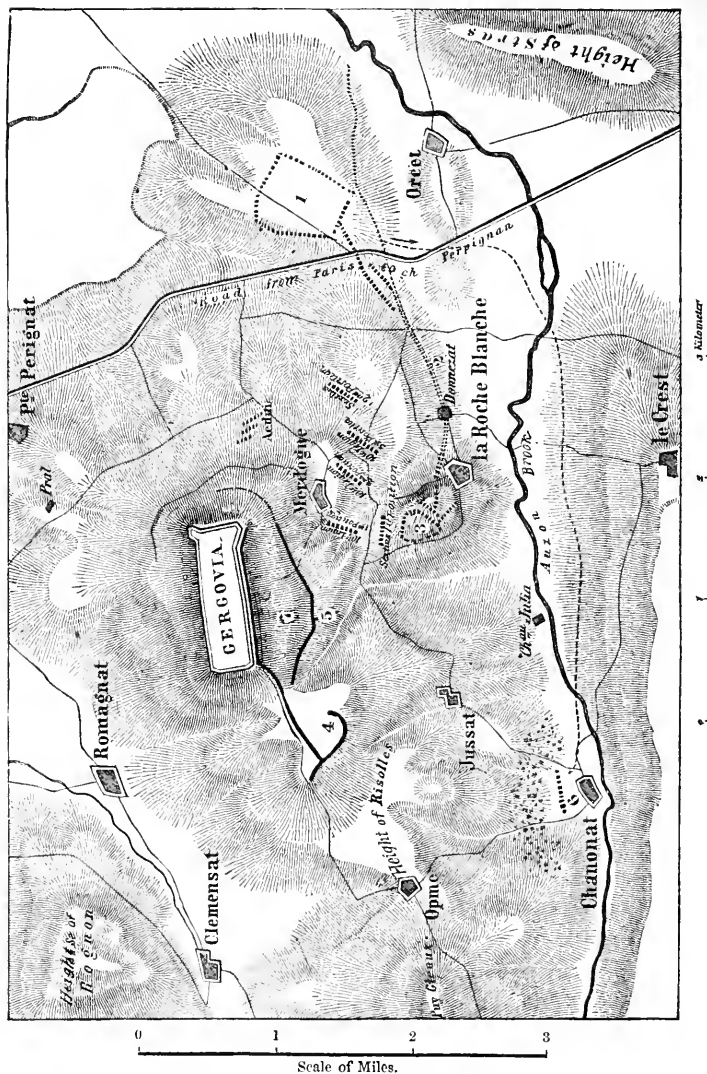

Plan IX. *Siege of Gergovia.* Bk. VII. Chap. 36-53.

1. Cæsar's large camp. 2. The double trench connecting the camps. 3. The small camp.  
4. Gallic fortification. 5. Gallic wall. 6. Detached legion. 7. Gallic camp.

CHAP. 35. *e regione castris* (dat.), *over against the* [other] *camp.*

**159.** *captis*: this word (marked as doubtful or corrupt) is no doubt an error for some word signifying "set in position."

3. *pars inferior*: *the lower end* of the piles, which (being under water) was not burned or cut away, served as a support to the new bridge hastily constructed for the crossing.

CHAP. 36. *quintis castris*, *at the fifth encampment*, or end of the fifth day's march. See note on Bk. I. Chap. 10<sup>3</sup>. — *expugnatio*, *taking* (it) *by storm*, without a formal siege.

2. *qua despici poterat*, *where a view could be had from above.*

3. *collis*: the so-called *Roche Blanche* ("White Rock"), at whose foot flows the only sufficient stream of water (see Plan IX.). Cæsar's larger camp, it will be remembered, lay towards the south-east of the town (Plan IX. 1), and the smaller towards the south (Plan IX. 3); while the forces of the Gauls (Plan IX. 7) lay on the gentler southern slopes of the hill (measuring nearly a mile from east to west, and a third as much from north to south) on which the town was built (see Chap. 46<sup>2</sup>). — *duodenum pedum* (Plan IX. 2): see note on Bk. I. Chap. 49, "The Camp," 3.

**160.** CHAP. 37. 2. *imperio natos*, *born for command* (dat.).

3. *unam civitatem*, *the one only state.* — *traducta*, *carried over* to the patriotic party. — *beneficio*, *a friendly act*, i.e. deciding in his favor; but this (he claimed) was only his due, — *sic . . . obtinuerit.*

5. *vel principes*, not mere followers or adherents.

CHAP. 38. 2. *principes civitatis*: see Chap. 39.

**161.** 5. *consilii res*, *a matter for deliberation.*

7. *fiduciā*, *under the protection*, to bring in supplies. — *unā* (adv.), *with him.*

CHAP. 39. *genere dispari*, *of lower birth.* — *traditum* is here equivalent to *commendatum* — "presented" as suited for public service.

4. *levi momento*, *of light account*: *momentum* (from *moveo*) is strictly the weight which "moves" the balance-scale.

**162.** CHAP. 40. 2. **contrahenda**: as only two legions were left behind, the camp should have been "contracted," so that these few might be equal to the task of keeping and relieving guard. The danger to which the situation exposed them is related in the next chapter: **propter magnitudinem castrorum** (Chap. 41<sup>2</sup>).

4. **necessario . . . labore** = *by the hardship of a forced march*. It is worth while to notice the frank terms on which Cæsar stands with his citizen-soldiers.

CHAP. 41. 3. **tormenta**: see note on Bk. II. Chap. 8<sup>3</sup>.

4. **discessu eorum**, at the suspension of their attack when night came on: his messengers had apparently set out about midnight. — **obstruere**, &c. These present infinitives show that his preparations are still going on.

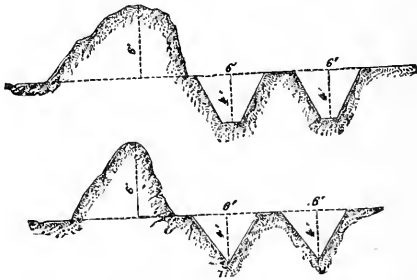

**Fig. 43.** Sections of the Double Trench

Connecting the two camps at Gergovia; as shown by the excavations under Napoleon III.

**163.** CHAP. 42. **levem auditionem**: see Bk. IV. Chap. 5<sup>3</sup>.

3. **proclinatam**, "leaning forward" like a wall just ready to fall = *in itself perilous*.

4. **fide data**, *giving pledges* of security. — **idem facere**, i.e. to come out and put themselves in their power.

CHAP. 43. **capti**, &c., *tempted* (as they had been) *by the profit of the plunder*. — **ea res**, i.e. responsibility for it.

4. **ab**, *away from* (the neighborhood of). — **contraheret**, i.e. join his forces with the four legions of Labienus (Chap. 34).

**164.** CHAP. 44. 2. **dorsum**, &c. (observe that the word is here masculine): the hill (*collis*) was south-west of the town and north-west of Cæsar's smaller camp (see plan); while from it a narrow wooded ridge (*dorsum*), nearly level, gave easy access to the town at its western side. Most of the Gallic force had been transferred to that side from the eastern and southern defences.

3. **uno . . . occupato**: see Chap. 36<sup>4</sup>.

CHAP. 45. 2. **impedimentorum**, *beasts of burden*.—**stramenta**, *the pack-saddles*, which would prevent the animal from being ridden on conveniently.—**collibus** (loc. abl.) **circumvehi**, i.e. towards the westerly side.

6. **raros**, *a few at a time*.

**165.** 8. **ab dextra parte**, from the larger camp, to the east.

CHAP. 46. **recta regione**, *in a straight line*.—**huc**, *to this amount*.

2. **in longitudinem**, &c. = *lengthwise of the hill*.—**murum**: traces of this wall are still found, at some distance down the slope, parallel with the town wall (see Plan IX. 5).—**castris** (see Plan IX. 7): the separate camps of the several Gallic states, set close together, of which three (*trinis*) were taken.

CHAP. 47. **receptui**: Cæsar appears to have found the enemy here in greater force than he expected, though (as usual) he claims to have gained all he wanted.

2. **reliquarum**, i.e. those engaged in the assault just described.—**retinebantur**, conative: the officers tried to hold them back.

5. **Avarici**: see Chap. 28.

**166.** CHAP. 48. **supra**: see Chap. 44.—**oppidum . . . teneri** depends on **nuntiis** as a word of *telling*.

3. **sustinebant**, by serving as relief or reserves.

CHAP. 49. **sub infimo colle**, at the foot of the main hill (Chap. 46), not that on which was the smaller Roman camp.—**ab . . . hostium**, i.e. on the Roman left; Cæsar, meanwhile, was posted considerably to the right (eastward).

CHAP. 50. **latere aperto**, *the exposed flank* of the Romans, i.e. the right flank.—**manus**, *scattered forces* of the Gauls.

**167.** 2. **insigne pacatum** (other editors have *pacatorum*), a friendly signal.

4. **excīdere**, to cut away; it does not appear whether from within, to gain his own escape, or from without, to relieve those who were being slaughtered in the town.

CHAP. 51. **aequiore loco**, on more level ground, farther back from the town.

2. **locum superiorem**, higher ground, in the direction of the larger camp. The retreat was made in good order, as is shown by what immediately follows.

CHAP. 52. **cupiditatem**, eagerness for battle.

2. **ad Avaricum**, referring to the operations in that neighborhood described in Chap. 19. Compare also Chap. 45<sup>8</sup>.

**168.** CHAP. 53. **virtuti hostium**: a change in Cæsar's feeling towards his foes has been noticed here, as if after his reverses he grudged them his former praise of their bravery. — **eadem . . . senserat**: he returns to his former plan of falling back (compare Chaps. 43<sup>5</sup> and 44).

2. **secundo**, favorable to the Romans. By this slight success, and the refusal of Vercingetorix to meet him in the plain on even terms, Cæsar avoids the appearance of a compulsory retreat.

CHAP. 54. **Viridomaro**, &c.: see Chap. 39.

2. **perfidiam . . . habebat**; see note on **coactum habebat**, Bk. I. Chap. 15.

3. **discedentibus** (dat.), as they were setting out. — **quam humiles**: see Bk. I. Chap. 31.

**169.** 4. **mandatis**: this word implies that what he has just said to them is to be repeated to their countrymen at home.

CHAP. 55. **Noviodunum**, the modern *Nevers*, on the right bank of the Loire (*Liger*), just above its junction with the Allier (*Elaver*). The Noviodunum of Chap. 12 is probably *Saucerre*.

2. **civitatis**: the Ædunan commonwealth. The *status* is described in the clause which follows, down to **missos**.

4. **in Provinciam**: Cæsar was now on the western or further

bank of the Loire, which he would thus be obliged to follow up towards its source, thence crossing over to the Province.

CHAP. 56. *si esset, &c.* = *in case (i.e. lest) he might have to risk a battle while the bridge-building was under way.*

**170.** 2. *Labieno, legionibus*, datives following *timebat*.

3. *pro rei necessitate*, *considering the emergency*, difficult and hazardous as it was. — *disposito equitatu*: just above the ford a line of cavalry was formed, in the water, reaching across the river. By this barrier the violence of the current was checked.

CHAP. 57. *eo supplemento*: see Chap. 1<sup>1</sup>, 7<sup>5</sup>. — *Lutetiam*, Paris: see Bk. VI. Chap. 3 and note.

2. *Aulercos*: this tribe was the next westerly, south of the Seine (see map).

3. *perpetuam paludem*, the marsh ground along the little river *Essonne*, which flows into the Seine on the south a little above Paris. Labienus was proceeding on the left or southerly bank of the Seine. See Plan X.

CHAP. 58. *aggere*, *a mass of earth* for a causeway. — *confieri*, rare for *confici* (the form *fieri* is regular only in compounds — *not* with prepositions — which retain *-facio*). — *Melodunum*, *Melun*: here Labienus crosses to the right bank.

3. *eo*, *aboard (= in eos)*.

**171.** 4. *secundo flumine*, *following the river-course down* the right bank. Having boats or pontoons, he would easily cross the *Marne* just above Paris.

5. *projecta palude*, *a marshy ground south of the river*. — *e regione*, *over against*.

CHAP. 59. *secundo*, *successful*. — *confirmabant*, *kept asserting*.

2. *qui* refers to *Bellovaci*.

4. *alterā, alteram*: the Bellovaci were on the north of the Seine, Camulogenus was (Chap. 57<sup>2</sup>) on the south. — *quae civitas*: see Bk. II. Chap. 4. — *praesidio, &c.*: these were at Agedincum (*Sens*), far up the Seine.

CHAP. 60. *equitibus*, *not cavalrymen*, but unattached officers

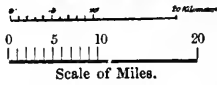
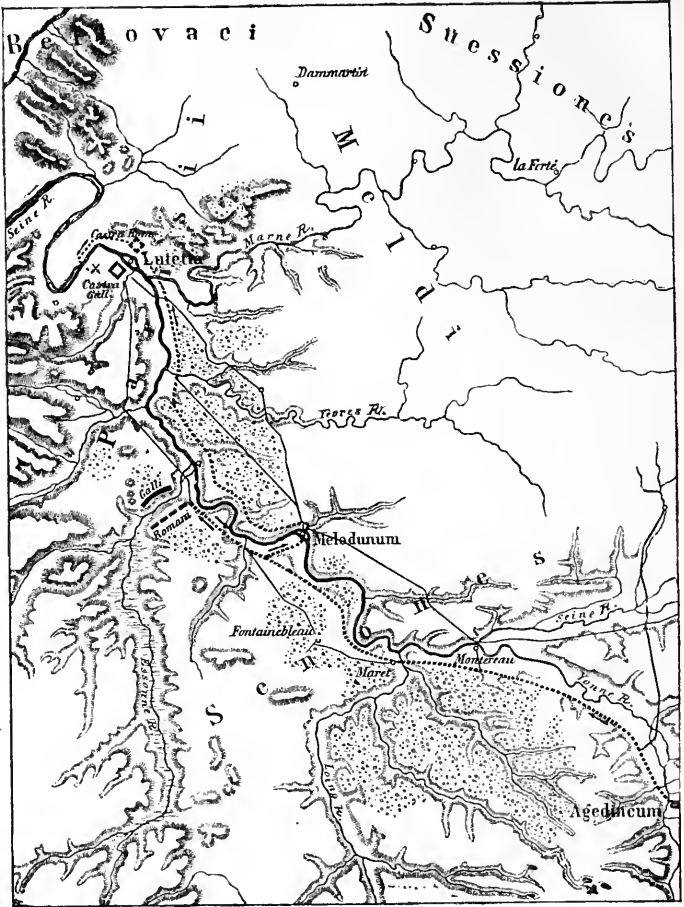

Plan X. March of Labienus against Lutetia. Bk. VII. Chaps. 59-62.



of equestrian rank (*tribuni militum, comites imperatoris, &c.*) put in charge each of a single vessel.

2. **adverso flumine**, a feint, the real attack being made below. — **imperat**, *gives orders* (followed by the acc. and infin. instead of the usual *ut*-clause).

**172.** CHAP. 61. 2. **tumultuari**: the **magno tumultu** (Chap. 60<sup>2</sup>). — **paulo infra**, about four miles below.

4. **castrorum**, the Roman camp. — **naves**, the *lintres*.

**173.** CHAP. 62. **neque potuerunt**, *but could not*.

CHAP. 63. **circummittuntur, &c.**: these are the acts of the Ædui.

2. **quos Caesar, &c.**: see Chap. 55. — **supplicio**, i.e. by threats; compare Chap. 4<sup>7</sup>. — **rationes communicet**, not simply consult, but share the direction of affairs.

5. **illi**, the Remi (see Bk. II. Chap. V.; Bk. V. Chap. 54), and the Lingones.

6. **requirunt** = *recall with regret* (compare the French *regretter*).

7. **summae spei**, *of high ambition* (Chap. 39).

CHAP. 64. **huc**, at Bibracte (Chap. 63<sup>3</sup>). A better reading of this clause, though having less authority, is *diemque huic rei constituit*.

**174.** 3. **aequo modo animo**, *without complaint, meanwhile*.

4. **finitimi**: see Introduction, p. xv.

5. **altera ex parte**: as the Roman frontier was bent into an irregular curve by the line of the Cevennes, the Gauls would strike the Province in two directions, the Ædui from the west, the Ruteni, &c., from the north.

6. **superiore bello**, the war of eight years before, in which the Allobroges had been subdued by Pomptinus (Bk. I. Chap. 6).

CHAP. 65. **cohortium**, not legionary troops, but auxiliaries levied in the Province. — **L. Caesare**, a cousin of Julius, consul B.C. 64.

2. **Donnotauro**, a brother of Procillus (Bk. I. Chap. 47<sup>4</sup>); the Roman name (*C. Valerius*) is regularly taken in compliment to his

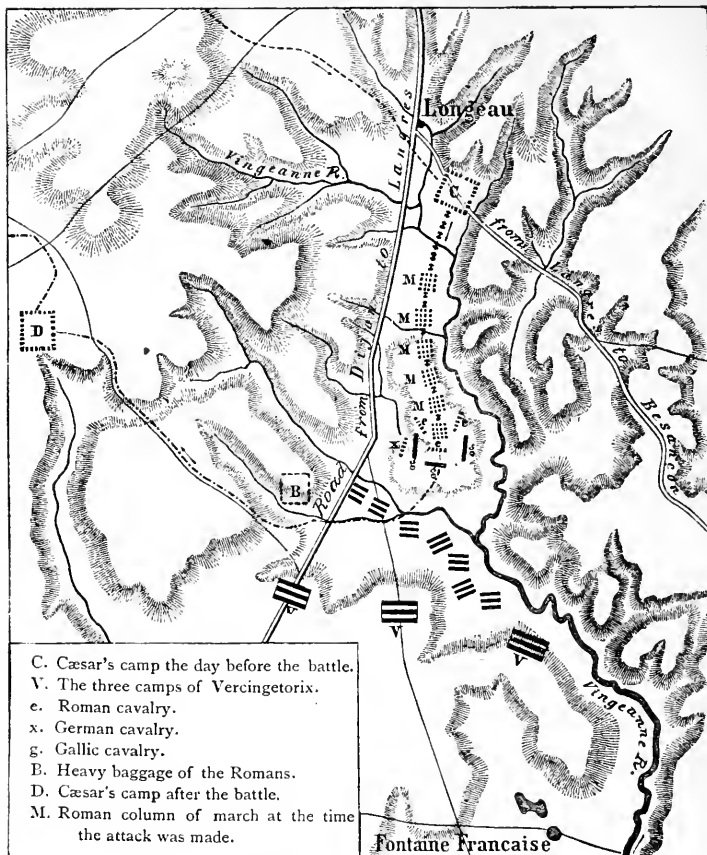

**Plan XI.** *Defeat of Vercingetorix on the Vingeanne.* Bk. VII. Chaps. 66-67.

Roman *patronus* (see also Bk. I. Chaps. 19, 53). — **muros**, *strongholds* — not simply the walls of the *oppida*.

4. **inter eos proeliari**: see Bk. I. Chap. 48<sup>5</sup>.

5. **sed et**: these words should probably be omitted.

**175.** CHAP. 66. **equites**: see Chap. 64<sup>1</sup>.

2. **per . . . fines**, bearing from near Agedincum (where he had been joined by Labienus, Chap. 62) toward the east, and so leaving the hostile Ædui to the south. This movement, checked by the attack of Vercingetorix, explains how the crisis of the campaign came to be the siege and capture of Alesia (see map).

4. **adorirentur** (subj. for imperat. of direct discourse), *charge upon them!* — **pedites**, the Roman foot; Vercingetorix knew Cæsar's weakness in cavalry, and did not suspect the German reinforcement. To infantry, any delay in defending whatever part might be attacked (**suis**) would be fatal. — **dignitate**, &c.; i.e. the dishonor of retreat with loss of baggage.

5. **de, as to**. — **quin . . . audeat** follows **ne . . . dubitare**. — **ipsos quidem** = *such men as they* — victorious as they were just now at Gergovia. — **et quo**: another reading is **Id quo**, beginning a new sentence, and making the passage from **si pedites** to **dubitare** parenthetical. — **pro castris**, *in front of the camp*, by way of defiance.

CHAP. 67. **primo agmine** (loc. abl.), *at the front of the* [Roman] *line of march*. Some copies have **a primo agmine**.

3. **aciem constitui**: by a change of front turning the line of march to a line of battle.

**176.** 5. **quo duce**, &c. (see Bk. I. Chap. 31): this was seemingly another Eporodrix, not the rival of Viridomarus.

CHAP. 68. **Alesiam**: this famous fortress (now called *Alise St. Réine*) was on the territory lying just north of the Ædian frontier. Its natural advantages — summed up in the succeeding chapters — are thus described: —

“Alesia, like Gergovia, is on a hill sloping off all round, with steep, and, in places, precipitous sides. It lies between two small rivers, both of which

fall into the Brenne, and thence into the Seine. Into this peninsula, with the rivers on each side of him, Vercingetorix had thrown himself with 80,000 men. Alesia as a position was impregnable except to famine. The water-supply was secure. The position was of extraordinary strength. The rivers formed natural trenches. Below the town, to the west, they ran parallel for three miles through an open alluvial plain before they reached the Brenne. In every other direction rose rocky hills of equal height with the central plateau, originally perhaps one wide table-land, through which the water had ploughed out the valley. To attack Vercingetorix where he had placed himself was out of the question; but to blockade him there, to capture the leader of the insurrection and his whole army, and so in one blow make an end with it, on a survey of the situation seemed not impossible." — *Froude's Cæsar*.

CHAP. 69. 3. **quæ pars** has for an antecedent **hunc locum**.

4. **munitiois**: Cæsar constructed a line of *contravallation*; i.e. a series of works entirely surrounding the town, so as to resist a sortie. — **milium**: this genitive requires some such word as **spatium** to be understood after **tenebat**. Some editions read **milia**. In the remains of these works traces have been found of four infantry and four cavalry camps (see Plan XII.).

5. **stationes**, &c.: in the daytime a mere picket-guard occupied each redoubt; at night it was necessary to station in them strong garrisons with numerous sentries (**excubitoribus**) on their walls.

**177.** CHAP. 70. **pro castris**: these were on the high ground south of the city (see Plan XII.); **castris** is plural, *campis*.

3. **angustioribus**, *too narrow*, either from unskilful construction, or more easily to prevent the enemy's entrance. — **relictis**: it is conjectured that this word does not belong here, being an error of some copyist, whose eye caught the same word two lines below.

5. **portas**, *town gates*; these were closed, lest those who manned the exterior defences (the **fossa** and **maceria**) should rush into the town in a panic.

CHAP. 71. 4. **ratione inita**, *having taken an account*.

5. **opus**, the Roman works of *contravallation*, still unfinished.

6. **copias omnes**: not those that held the fortification east of the town, but the outlying pickets on all the other sides.



178. CHAP. 72. *pedum viginti*, i.e. in breadth. — *directis*,

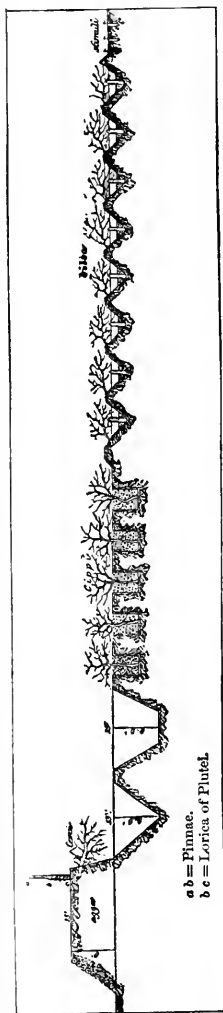

ab = Pinnæ.  
bc = Lorica of Plutei.

Fig. 44. Section of Cæsar's Contravallation at Alesia.

*vertical*, the bottom (*solum*) being as broad as the top. The ditch was usually dug with sloping sides; the object here was (as it was probably shallow) to make it harder to cross. See note on Bk. I. Chap. 49, "The Camp," 3. This was the *contravallation*, the interior line of defence, against the town.

2. *totum corpus*, the entire work, eleven miles in extent, according to Chap. 69<sup>4</sup>. — *operi*, take with *destinatos*.

3. *eadem altitudine*, of equal depth. — *interiorem*: i.e. nearer the town. — *locis*, loc. abl.

4. *loricam*, *pinnas*: see Bk. V. Chap. 40, and also note on Bk. I. Chap. 49, "The Camp," 8. — *cervis*, stumps with roots, or trunks with branches, projecting like stags' horns. — *ad*, at. — *pluteorum*: the *lorica* was really a series of *plutei*, arranged side by side on the wall and bound together. — *turres*: if these were 10 ft. wide at the base, there must have been at least 400.

CHAP. 73. 2. *truncis arborum*, &c.: trunks of trees having very stiff boughs were cut down, the boughs being trimmed and sharpened at the ends, and then planted in five rows in trenches five ft. deep (*quinos pedes*), and perhaps one and a half ft. wide.

179. 3. *quini . . . ordines*: these five rows of *chevaux-de-frise*, intertwined so as to be continuous, covered a space perhaps 25 ft. wide, so that, even

with the help of a pole, an enemy could not easily leap over them. — **cippos**, "boundary-stones," so called jestingly by the troops.

4. **scrobes**, *little pits*, with sloping sides, three feet deep, dug in eight rows, arranged, as we should say, in diamond-pattern, or as trees were planted in an orchard (*in quincuncem*), so that each should be equally distant from the six adjacent. A stout, sharp stake was set in each, packed with a foot depth of earth, its point projecting four inches, the pit being then loosely filled with twigs and brush. This elegant funnel-shaped trap for man or beast the soldiers called a "lily-cup" (*lilium*).

5. **teretes**, *round*, like a stick, while the word **rotundus** means round like a ball.

6. **totae**, *their whole length*, so that only the hooks projected.

CHAP. 74. **regiones . . . aequissimas**: the line of circumvallation (see Plan XII.) was parallel with the works just described, and distant from it about 700 ft. It was protected by a single ditch. — **XIV milia**: of course the works of circumvallation included all the Roman camps, and must have had a greater circuit than the inner line of contravallation (see Chap. 69<sup>a</sup>). — **diversas**, *facing the other way*. — **si discessu**: this passage is irregular in syntax and confused in meaning; doubtless corrupt. The sense is, perhaps, *that he might not be driven to a retreat by ever so great an attacking force*. — **habere . . . convectum**: see note on **compertum habere**, Bk. I Chap. 44.

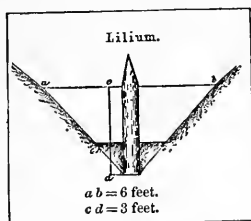

Fig. 45. *Lilium*.

180. CHAP. 75. **Boiis**: the blank is conjecturally filled by **bina**. — **quo in numero**: compare Bk. III. Chap. 7.

3. **pro**, *in consideration of*. — **unā**, *along with* the rest.

CHAP. 76. **operā Commii**: see Bk. IV. Chaps. 21, 35; Bk. V. Chap. 22. — **civitatem**, the Atrebatas. — **immunem**, *free from tribute*. — **ipsi**, sc. **civitati**. — **attribuerat**, *had annexed* as a subject state.

3. **Vercassivellauno**: in this word, as in *Vercingetorix*, the prefix *Ver* is probably a title, like the modern "Sir."

5. **ancipiti**, *with double front*, having to be fought behind and before.

**181.** CHAP. 77. 3. **deditionis**, a mere "laying down of arms."

4. **mollities**, compare Chap. 20<sup>5</sup>.

5. **atque**, *and then, too*.

6. **quid animi**, *what heart?*

8. **animi causā**, *for the pleasure of it*.

9. **illorum**, the Gauls; **his**, the Romans.

**182.** II. **illi bello**, dative after **simile**.

13. **finitimam**, "over the border" — the Province. — **securibus**, the licitor's axes, the sign not simply of military rule, but of bloody execution (as a servile insurrection would be revenged).

CHAP. 78. 2. **prohibebat**: "cruel, but war is cruel; and where a garrison is to be reduced by famine, the laws of it are inexorable."

CHAP. 79. **colle**: this hill is south-west from Alesia, beyond the Brenne.

**183.** CHAP. 80. 4. **complures**, of the Roman cavalry.

5. **neque . . . ac**, perhaps a misreading for **neque . . . nec**.

CHAP. 81. **atque**, *and even*. — **harpagonum**, iron hooks fastened to poles, for tearing down the defences.

**184.** **campestres munitiones**, *the works in the plain*; i.e. the line of circumvallation in the Plain of Laumes, south-west from Alesia.

2. **crates**, *hurdles* of woven twigs, to fill up the trenches.

4. **librilibus**, heavy stones fastened to a thong, by which they were hurled with great force. — **glandibus**, leaden bullets.

CHAP. 82. 2. **superioribus**, on the higher ground to the north and south (see next chapter).

3. **fossas**: this word should probably be **fossam**. It seems to refer to the ditch 20 ft. wide.



CHAP. 83. 2. *collis*: the camp of these two legions (Plan XII. D) was on the southern slope of *Mont Rea*.

**185.** CHAP. 85. 3. *iniquum . . . fastigium*, the unfavorable downward slope of the ground (see Chap. 83<sup>2</sup>).

**186.** 4. *agger, earth*.

CHAP. 86. *Labienum*: he was encamped on the heights of *Bussy* (Plan XII. C).

3. *interiores*, the Gauls within the town.—*loca praerupta*: probably the Heights of *Flavigny*.—*ex ascensu*, by assault.

CHAP. 87. *integros*, i.e. troops that had not yet been engaged. The cohorts of Brutus and Fabius were probably of those that had been defending the works in the plain.

2. *eo, &c.*: i.e. in the works on *Mont Rea*.

CHAP. 88. *ex colore*, the purple *paludamentum*.—*insigni*, as a badge.—*de locis superioribus*, from the high ground occupied by the Gauls.—*declivia*, on the downward slope.

**187.** 2. *equitatus*, who had been despatched as told in Chap. 87<sup>2</sup>.

5. *crebris subsidiis*, the constant sending of relief.

CHAP. 89. *Vercingetorix deditur*: the fate reserved for this gallant and ill-fated chieftain was to be kept for six years in chains, and then, after being led in Cæsar's triumphal procession, to be put to death.

From 1862 to 1865 careful excavations were made under direction of the emperor Napoleon III. on the site of the works at Alesia. The discoveries that resulted were most interesting. There were found the remains of Cæsar's four infantry camps (Plan XII. A B C D) and of his four cavalry camps (G H I K). Of the 23 redoubts, remains of only 5 could be traced. It is likely that the rest were mostly of wood, so that they soon crumbled entirely away. The trench 20 ft. wide (f f) remains in its entirety. Of the pits (*lilia*) in which the sharp stakes were buried, more than 50 were discovered. They are all 3 ft. deep, 2 ft. wide at the top, and 1 ft. wide at the bottom. Of course they do not retain the original

dimensions. In the trenches was found a great number of coins, Roman and Gallic, swords, daggers, spear-heads, and the like. The result of these researches was a very striking corroboration of Cæsar's narrative.

CLOSE OF THE CAMPAIGN. — If Cæsar was merciless in war, he was wise and humane in victory. Even in the moment of the fall of Alesia, he uses his prisoners to make terms with the more important states (*si per eos, &c.*). His aim was "not to enslave the Gauls, but to incorporate them in the Empire; to extend the privileges of Roman citizens among them, and among all the undegenerate races of the European provinces. He punished no one. He was gracious and considerate to all, and he so impressed the central tribes by his judgment and his moderation, that they served him faithfully in all his coming troubles, and never more, even in the severest temptation, made an effort to recover their independence." \*

Cæsar's own narrative closes with the great and decisive victory at Alesia. The short remainder of the story is told by his faithful officer and friend, Hirtius Pansa, in the Eighth Book. A rising of the Carnutes and Bituriges in the west, undeterred by the fate of Avaricum, was crushed by a rapid winter march across the Loire. The Remi in the north, who alone of the Gauls had been steadily true to Rome, were attacked in retaliation by the Bellovaci under Commius, but were crushed in a single battle, and Commius fled to Germany. The final rally of the patriot party was made at the stronghold of Uxellodunum, on a branch of the Garonne, in the south-west; but this was also reduced by a siege of extreme difficulty, and the one act of vindictive barbarity which stains Cæsar's record was inflicted after its fall by cutting off the hands of the desperate defenders who had held out to the last for the independence of Gaul. Cæsar then "invited the chiefs of all the tribes to come to him. He spoke to them of the future which lay open to them as members of a splendid imperial state. He gave them magnificent presents. He laid no impositions either on the leaders or their people; and they went to their homes personally devoted to their conqueror, contented with their condition, and resolved to maintain the peace which was now established,—a unique experience in political history."

THE LEGIONS. — In the operations of this year (52 B.C.) Cæsar used the 10 legions with which the previous year saw him provided. Legions I and III had been loaned him by Pompey (see note on Bk. VI. Chap. 1<sup>4</sup>).

\* The student of Bk. VII. will do well to read, in connection with it, the admirable condensed narrative given in Froude's "Cæsar," from which the above extract is taken.

Legions VII, VIII, IX and X Cæsar found stationed in his provinces when he assumed the proconsulship in the year 58. Legions XI and XII he enrolled in Hither Gaul in the spring of that year, to operate against the Helvetians. Legion XIII was raised in Hither Gaul in 57. Legion XIV was raised in 53. The previous (half) Legion XIV and Legion XV had perished with Sabinus in 54 B.C.

# MILITARY INDEX.

Numbers refer to Pages of Notes.

- acies, 35, 87, 88, 185.  
acies duplex, 116.  
acies triplex, 35, 123.  
agger, 57, 77, 79 *et seq.*, 110, 140,  
170, 173, 174, 181.  
agmen, 38, 86 *et seq.*  
agmen extremum, 89.  
agmen novissimum, 28, 89.  
agmen quadratum, 87, 88, 91.  
ala, 34, 92.  
alarii, 63.  
amentum, 148.  
aquila, 39.  
aquilifer, 39.  
aries, 101.  
ballista, 75.  
balteus, 4.  
bracca, 3.  
buccina, 72, 94.  
calceus, 3.  
calo, 71, 86.  
cassis, 3.  
castellum, 21, 74, 76, 161, 191.  
castra, 56, 57, 70, 104, 177, 179, 186,  
191.  
catapulta, 75.  
centuria, 17, 35, 70.  
centurio, 17, 35, 49.  
cibaria, 15.  
cippi, 189.  
circumvallare, 189.  
clamor, 95.  
cohors, 35, 49, 70, 97, 183.  
cohors praetoria, 48, 52.  
comites, 48.  
concilium, 43, 138.  
concursum, 35.  
consilium, 145.  
contabulare, 147, 172.  
contravallare, 186.  
contubernales, 48, 85.  
convallis, 146.  
cornu, 64, 94.  
crista, 3.  
cruralia, 3.  
cuniculi, 115, 172  
decuria, 34.  
decurio, 34.  
ephippiis, 119.  
equitatus, 28, 34, 92.  
equites, 34, 71, 121, 134, 139, 152,  
155, 181.  
essedum, 130, 134.  
essedarii, 130, 134.  
excubiae, 186.  
expediti milites, 90.  
exploratores, 25, 71, 72, 77, 79.  
fabri, 75, 141.  
falces, 112, 148.  
feminalia, 3.  
ferrum, 4.  
fossa, 57, 74, 186, 188.

- frumentum, 29.  
 funditores, 73.  
 furca, 24.  
 gaesum, 104.  
 galea, 3.  
 gladius, 4, 38.  
 hastati, 87.  
 hiberna, 67, 104.  
 impedimenta, 85, 88 *et seq.*, 152.  
 imperium, 17, 32, 115, 152.  
 insignia, 33, 96.  
 iter, 23.  
 itineris consuetudo, 86 *et seq.*  
 jugum, 19.  
 latus apertum, 38, 97, 179.  
 legatus, 22, 27, 32, 62, 64.  
 legio, 17, 35, 52, 66, 68, 102, 117,  
     130, 135, 136, 145, 149, 151, 165,  
     192.  
 librilia, 190.  
 liliium, 191.  
 lituus, 94.  
 locus alienus, 28.  
 locus superior, 35, 40, 57.  
 locus suus, 28.  
 lorica, 3, 60, 147, 188.  
 maceria, 186.  
 manipulus, 17, 35, 70, 163.  
 manipulos laxare, 98.  
 matara, 40.  
 muli Mariani, 24.  
 munire castra, 57.  
 munitio, 22, 186, 190, 191.  
 murus, 20, 172.  
 naves, 106, 111.  
 naves subducere, 137.  
 ocrea, 3.  
 oppidum, 14, 144.  
 oppugnatio, 73, 77.  
 optio, 49.  
 opus dimetiri, 71.  
 orbis, 98, 136.  
 ordo, 17, 35, 49.  
 pabulum, 29, 68.  
 pagus, 26, 118.  
 passus, 10.  
 pedem referre, 38.  
 pelles, 85, 104.  
 phalanx, 37, 64.  
 pilani, 87.  
 pilum, 4, 35, 76.  
 pila muralia, 147.  
 pinna, 60, 147, 188.  
 pluteus, 78 *et seq.*, 188.  
 pons, 26, 125.  
 porta, 57, 61, 62, 116, 162, 186.  
 praefectus, 106.  
 praesidium, 21.  
 primipilus, 50, 98.  
 principes, 87.  
 quaestor, 64.  
 sagittarii, 175.  
 sagulum, 148.  
 sagum, 3, 23.  
 sarcinae, 24, 35, 85 *et seq.*  
 scorpio, 75.  
 scrobes, 189.  
 scutum, 3, 96.  
 sectionem vendere, 102.  
 signa, 39, 163.  
 signa conferre, 97.  
 signa convertere, 38, 98.  
 signa inferre, 38, 98.  
 signifer, 39, 97.  
 signum, 72.  
 signum pugnae, 95.  
 soldurii, 115.  
 speculatores, 71, 77, 79, 132.  
 stationes, 71, 72, 143, 186.  
 stipendium, 4.  
 tabernaculum, 71, 104.  
 terga vertere, 38.  
 testudo, 37, 78, 148.  
 testudinem facere, 73, 140.  
 titulum, 57, 72.  
 tormenta, 75, 76, 78, 80, 107.

- |  |                                 |
|--|---------------------------------|
| tragula, 40.                             | umbo, 4.                        |
| tribuni militum, 17, 62.                 | valli, 60.                      |
| tuba, 94.                                | vallum, 57, 105.                |
| tunica, 3.                               | vexillarius, 39, 97.            |
| turma, 34, 92.                           | vexillum, 39, 95.               |
| turris, 78, 97, 107, 147, 172, 173, 188. | vigilia, 72.                    |
| turris ambulatoria, 79.                  | vinea, 78 <i>et seq.</i> , 174. |

# GEOGRAPHICAL INDEX.

PREPARED BY H. P. JUDSON.

The approximate latitude and longitude refer to Map 1.

The figures next following show on what other map or maps the name is found.

The book and chapter are then cited for each occurrence of the name in the Gallic War.

**Aduatuca**: Lat.  $50^{\circ}$ - $52^{\circ}$  N., Long.  $4^{\circ}$ - $6^{\circ}$  E.; 4; VI. 32, 35. A fortified town of the Eburones (probably the modern *Tongres*). To be distinguished from (**Aduatucorum**) **oppidum**, *q. v.*

**Aduatucl**: Lat.  $50^{\circ}$ - $52^{\circ}$  N., Long.  $4^{\circ}$ - $6^{\circ}$  E.; 4; II. 4, 16, 29, 31; V. 27, 38, 39, 56; VI. 2, 33. A Belgic tribe of German descent.

**Aedui**: see **Haedui**.

(**Aduatucorum**) **oppidum**: Lat.  $50^{\circ}$ - $52^{\circ}$  N., Long.  $4^{\circ}$ - $6^{\circ}$  E.; II. 29. A fortified town of the **Aduatucl**. Napoleon III. considers it to have been on the hill where the citadel of *Namur* is now situated (see Plan VI.), at the confluence of the *Sambre* with the *Meuse*. Göler places it at Mount *Falhize*, opposite *Huy*, on the *Meuse* some distance below *Namur*. By the context (II. 29) the circuit of the Gallic fortifications was 15,000 (Roman) feet; **quindecim millia** (*sc. pedum*) = about  $2\frac{3}{4}$  (English) miles. But the circuit of the Gallic fortifications on the plan of Napoleon III. is less than  $\frac{3}{4}$  of a mile (English); and on the plan of Göler about 5 miles. Of course in the lapse of centuries the hill may have changed its form and size; but

we do not know any reason sufficient to make so great a change in either of the two. Hence we can hardly regard the precise situation of this **Aduatuca** as satisfactorily proven. On Map 1 the town is placed at *Falhize*; on Plan VI. near *Namur*. Thus the two situations are both seen.

**Age(n)dicum**: Lat.  $48^{\circ}$ - $50^{\circ}$  N., Long.  $2^{\circ}$ - $4^{\circ}$  E.; 4, 6; VI. 44; VII. 10, 57, 59, 62. The chief town of the Senones, now *Sens*, in Champagne.

**Alduasdubis**: see **Dubis**.

**Alesia**: Lat.  $46^{\circ}$ - $48^{\circ}$  N., Long.  $4^{\circ}$ - $6^{\circ}$  E.; 2, 6; VII. 68, 69, 75, 76, 77, 79, 80, 84. A town of the Mandubii, now *Alise Ste. Reine*.

**Allobroges**: Lat.  $44^{\circ}$ - $46^{\circ}$  N., Long.  $6^{\circ}$  E.; 2, 6; I. 6, 10, 11, 14, 28; III. 1, 6; VII. 64, 65. A powerful Celtic tribe, conquered by Fabius Maximus, 121 B.C.

**Alpes**: Lat.  $44^{\circ}$ - $46^{\circ}$  N., Long.  $6^{\circ}$ - $8^{\circ}$  E.; 2, 6; I. 10; III. 1, 2, 7; IV. 10. The *Alps*, mountains dividing Italy from Gaul and Germany.

**Ambarri**: Lat.  $46^{\circ}$ - $48^{\circ}$  N., Long.  $4^{\circ}$ - $6^{\circ}$  E.; 2, 6; I. 11, 14. A Gallic tribe, clients of the Haedui.

**Ambiani**: Lat.  $50^{\circ}$ - $52^{\circ}$  N., Long.

2° E.; 4, 5; II. 4, 15; VII. 75. A Belgic tribe. Their chief town, Samarobriva, is the modern *Amiens*, so called from the name of the tribe.

**Ambibarii**: Lat. 48°-50° N., Long. 0°-2° W.; VII. 75. A tribe of Aquitania. In some texts called **Ambiliati**.

**Ambilarēti**: VII. 90. Probably the same as the **Ambarri**, *q. v.*

**Ambiliāti**: see **Ambibarii**.

**Ambivariti**: Lat. 48°-50° N., Long. 6°-8° E.; IV. 9. A Belgic tribe.

**Ambluareti**: VII. 75. Probably the same as the **Ambarri**, *q. v.*

**Anartes**: VI. 25. A Dacian tribe, at the eastern end of the Hercynian forest.

**Ancalites**: Lat. 50°-52° N., Long. 0°-2° W.; 5; VI. 21. A tribe of Britain.

**Andes**: Lat. 46°-48° N., Long. 0°-2° W.; II. 35; III. 7; VII. 75. A Celtic tribe.

**Aquilēia**: I. 10. A city of Hither Gaul, near the modern *Trieste*.

**Aquitania**: Lat. 42°-46° N., Long. 2° W.-2° E.; I. 1; III. 11, 20, 21, 23, 26, 27; VII. 31. The southwestern part of Gaul, inhabited principally by people of Iberian stock.

**Arar** (—*āris*): Lat. 46°-48° N., Long. 4°-6° E.; 2, 6; I. 12, 13, 16; VII. 90. The River *Saône*.

**Arduenna** (*Silva*): Lat. 50° N., Long. 4°-6° E.; V. 3; VI. 29, 31, 33. A mountainous region covered with forest, in the N.E. part of Gaul; the modern *Ardennes*.

**Arecomici**: Lat. 44° N., Long. 4° E.; 6; VII. 7, 64. See **Volcae**.

**Armoricae** (*civitates*): Lat.

46°-50° N., Long. 0°-5° W.; V. 53; VII. 75. The Gallic states on the seacoast, between the *Loire* and the *Seine*.

**Arverni**: Lat. 44°-46° N., Long. 2° E.; 6; I. 31, 45; VII. 3, 4, 5, 7, 8, 9, 34, 37, 38, 64, 66, 75, 76, 77, 83, 88, 89, 90. A powerful Celtic tribe.

**Atrebātes** (or **Atrebāti**): Lat. 50°-52° N., Long. 2°-4° E.; 3, 4; II. 4, 16, 23; III. 27, 35; IV. 21; V. 22, 46; VI. 6; VII. 75, 76. A Belgic tribe.

**Aulerci**: II. 34; III. 17, 29; VII. 4, 57, 75. A Gallic people in four tribes:—

1. The **Aulerci Brannovices**: Lat. 46°-48° N., Long. 4° E.; 2, 6.

2. **Aulerci Cenomani**: Lat. 48° N., Long. 0°-2° E.; 4.

3. The **Aulerci Diablintes**: Lat. 48°-50° N., Long. 0°.

4. The **Aulerci Ebuovices**: Lat. 48°-50° N., Long. 0°-2° E.; 4.

**Ausci**: Lat. 42°-44° N., Long. 0°; III. 27. A tribe of Aquitania.

**Axona**: Lat. 48°-50° N., Long. 4° E.; 2, 6; II. 5, 9. The River *Aisne*, a confluent of the *Isara*, now the *Oise*.

**Bacenis** (*silva*): Lat. 50°-52° N., Long. 8°-10° E. VI. 10. A forest of Germany.

**Baleāres**: II. 7. People of the Balearic Islands, in the Mediterranean, east of Spain.

**Batavorum Insula**: Lat. 50°-52° N., Long. 6° E. IV. 10. The passage (IV. 10) is rather obscure. It seems to mean that the Waal (**Vacalus**), a branch of the Rhine, falls into the Meuse; that the island



of the Batavians is formed by the Waal, the Meuse, and the Rhine; and that then at a distance of 80 miles from the ocean, the Meuse finally empties into the Rhine. At present the Meuse, empties into the ocean. There is no doubt that the shifting sands of these oozy lowlands have made and unmade many river channels in the nineteen centuries since Cæsar's day; so that it is perhaps not unlikely that his account was substantially correct. It must be remembered, however, that he wrote only from hearsay; and that such topographical information as he could gather in that way would perhaps be quite as vague as the rumors of rivers and lakes that came in our own day to Livingstone in the heart of Africa.

**Belgae**: I. 1; II. 1, 2, 3, 4, 5, 6, 14, 15, 17, 19; III. 7, 11; IV. 38; V. 24. A general name given to the tribes of the northern part of Gaul. Many of them were of German descent.

**Bellovaci**: Lat. 48°-50° N., Long. 2° E.; 3, 4, 5, 6; II. 4, 5, 10, 13, 14; V. 24, 46; VII. 59, 75, 90. A Belgic tribe.

**Bibraete (-is)**: Lat. 46°-48° N., Long. 4°-6° E.; 2, 6; I. 23; VII. 55, 63, 90. The chief town of the **Haedui**, now *Autun*.

**Bibrax (-etis)**: Lat. 48°-50° N., Long. 4°-6° E.; 3, 4; II. 6. A town of the Remi.

**Bibroci**: Lat. 50°-52° N., Long. 0°-2° E.; 5; V. 21. A tribe of Britain.

**Bigerriones**: Lat. 42°-44° N., Long. 0°-2° E.; III. 27. A tribe of the Pyrenees.

**Bituriges**: Lat. 46°-48° N., Long.

2° E.; 6; I. 18; VII. 5, 8, 9, 11, 12, 13, 15, 21, 29, 75, 90. A Celtic tribe.

**Boii**: Lat. 46°-48° N., Long. 2°-4° E., also 8°-10° E.; 6; I. 5, 25, 28, 29; VII. 10, 17, 75. A Celtic tribe. A part of them accompanied the **Helvetii** in their migration, and, at the request of the **Haedui**, were allowed by Cæsar to settle in *Hæduan* territory.

**Brannovices**: VII. 75. See **Aulerci**.

**Brannovii**: Lat. 46°-48° N., Long. 2°-4° E.; 2, 6; VII. 75. A Celtic tribe, clients of the **Haedui**.

**Bratuspantium**: Lat. 48°-50° N., Long. 2°-4° E.; 3, 4, 5; II. 13. A fortified town of the **Bellovaci**.

**Britannia**: maps 1, 4, 5; II. 4, 14; III. 8, 9; IV. 20, 21, 22, 23, 27, 28, 30, 37, 38; V. 2, 6, 8, 12, 13, 14, 22; VI. 13; VII. 76. The Island of *Britain*.

**Cabillonum**: Lat. 46°-48° N., Long. 4°-6° E.; 2, 6; VII. 42, 90. A town of the **Haedui**, now *Chalons-sur-Saône*.

**Cadureci**: Lat. 44°-46° N., Long. 0°-2° E.; VII. 4, 5, 7, 64, 75. A tribe of Aquitania.

**Caeroci**: Lat. 48°-50° N., Long. 6° E.; 4; II. 4. A Belgic tribe of German descent.

**Calètes (or Caleti)**: Lat. 48°-50° N., Long. 0°-2° E.; 4, 5; II. 4; VII. 75. A tribe near the mouth of the *Seine*.

**Cantabri**: Lat. 42°-44° N., Long. 2°-4° W.; III. 26. A warlike tribe of Spain.

**Cantium**: Lat. 50°-52° N., Long. 0°-2° E.; 4, 5; V. 13, 14, 22. The S.E. part of Britain, now *Kent*.

**Carcasso**: Lat. 42°-44° N., Long. 2°-4° E.; Notes, p. 114, chap. 20<sup>2</sup>. A town of the **Velcae Tectosages**, in the Province.

**Carnūtes**: Lat. 48°-50° N., Long. 0°-2° E.; 4; II. 35; V. 25, 29, 56; VI. 2, 3, 4, 13, 44; VII. 2, 3, 11, 75.

**Cassi**: Lat. 50°-52° N., Long. 0°-2° W.; 5; V. 21. A tribe of Britain.

**Caturiges**: Lat. 44°-46° N., Long. 6°-8° E.; 2, 6; I. 10. A tribe in the Province.

**Cenimagni**: Lat. 52°-54° N., Long. 0°-2° E.; 5; V. 21. A tribe of Britain.

**Cenomani**: VII. 75. See **Auleri**.

**Centrōnes**: Lat. 44°-46° N., Long. 6°-8° E.; 2, 6; I. 10. A tribe of the Province.

**Centrōnes**: Lat. 50°-52° N., Long. 2°-4° E.; 4; V. 39. A Belgic tribe.

**Cevenna (Mons)**: Lat. 44° N., Long. 2°-4° E.; 2, 6; VII. 8, 56. The *Cevennes* Mts.

**Cherusci**: Lat. 52°-54° N., Long. 10° E.; VI. 10. A German tribe.

**Cimbri**: I. 33, 40; II. 4; VII. 77. A German tribe, cut to pieces by the Romans in 103 and 102 B.C.

**Cisalpina Gallia (Gallia Citerior)**: VI. 1. The Gallic province on the Italian side of the Alps.

**Cisrhenāni**: Lat. 48°-52° N., Long. 4°-6° E.; VI. 2. The German tribes living on the Gallic side of the Rhine.

**Cocosātes**: Lat. 44°-46° N., Long. 0°-2° W.; III. 27. A tribe of Aquitania.

**Condrūsi**: Lat. 50°-52° N., Long. 4°-6° E.; 4; II. 4; IV. 6; VI. 32.

A Belgic tribe of German descent, clients of the **Treveri**.

**Curiosolites (Curiosolitae)**: Lat. 48°-50° N., Long. 2° W.; II. 34. An Armoric tribe.

**Daci**: VI. 25. The Dacians, a people of Thrace.

**Danubius**: VI. 25. The River *Danube*.

**Decetia**: Lat. 46°-48° N., Long. 2°-4° E.; 6; VII. 33. A town of the **Haedui**, on the Loire.

**Diablintres**: III. 9. See **Auleri**.

**Dubis**: Lat. 46°-48° N., Long. 6°-8° E.; 2, 6; I. 38. The River *Doubs*, a confluent of the **Arar** (the *Saône*).

**Durocortorum**: Lat. 48°-50° N., Long. 4°-6° E.; 3, 4, 6; VI. 44. The chief town of the **Remi**, near *Rheims*.

**Eburōnes**: Lat. 50°-52° N., Long. 6° E.; 4; II. 4; IV. 6; V. 24, 28, 29, 39, 47, 58; VI. 5, 31, 32, 34, 35; VII. 75. A Belgic tribe, clients of the **Treveri**.

**Elaver (-ēris)**: Lat. 46°-48° N., Long. 2°-4° E.; VII. 34, 35, 53. The *Allier*, an affluent of the **Liger** (the *Loire*). \*

**Eleutheri (Cadurci)**: VII. 75. A name given to the **Cadurci**, *q. v.*

**Elusātes**: Lat. 44° N., Long. 0°; III. 27. A tribe of Aquitania.

**Esvii**: Lat. 48°-50° N., Long. 0°; 4; II. 34; III. 7; V. 24. A Celtic tribe.

**Gabali**: Lat. 44°-46° N., Long. 4° E.; 6; VII. 7, 64, 75. A Gallic tribe, clients of the **Arverni**.

**Gallia**: I. 1, 2, 3, 7, 10, 16, 17, 19, 20, 24, 28, 30, 31, 33, 34, 35, 37,

43, 44, 45, 46, 53, 54; II. 1, 2, 3, 4, 35; III. 7, 11, 17, 20, 28; IV. 6, 8, 16, 19, 20, 29; V. 1, 2, 3, 5, 6, 8, 12, 13, 20, 22, 24, 27, 29, 41, 53, 54, 55, 56, 58; VI. 1, 3, 5, 11, 12, 13, 29, 31, 44; VII. 1, 3, 4, 6, 10, 15, 20, 25, 29, 31, 34, 37, 43, 55, 59, 63, 66, 71, 76, 77. In general, the whole of France, Belgium, Switzerland, and Northern Italy. In particular, the two Roman provinces, **Gallia Cisalpina**, reaching from the River Po to the Alps; and **Gallia Transalpina**, a strip of France along the coast of the Mediterranean. Also applied (at the beginning of Cæsar's proconsulate) to the country extending from the Pyrenees and the Roman province to the Rhine, and from the Alps to the ocean. This, at that time, was independent of the Roman power, and was divided loosely into three parts, Belgic and Celtic Gaul and Aquitania, *q. v.*; I. 1.

**Gallia (Transalpina) (Gallia Ulterior)**: VII. 1, 6. Gaul on the French side of the Alps. Before Cæsar's conquests it was merely a strip of land along the coast of the Mediterranean.

**Gates**: Lat. 42°-44° N., Long. 0°; III. 27. A tribe of Aquitania.

**Garumna**: Lat. 44°-46° N., Long. 0°; I. 1. The River *Garonne*.

**Garumni**: Lat. 42°-44° N., Long. 0°-2° E.; III. 27. A people of Aquitania, in the Pyrenees.

**Geidumni**: Lat. 50°-52° N., Long. 2°-4° E.; 4; V. 39. A Belgic tribe, clients of the *Nervii*.

**Genabenses**: VII. 11. The people of *Genabum*.

**Genabum**: Lat. 46°-48° N.,

Long. 2° E.; 6; VII. 11, 14, 17. The chief town of the *Carnutes*, now *Orleans*.

**Genáva**: Lat. 46°-48° N., Long. 6°-8° E.; 2, 6; I. 6, 7. The chief town of the *Allobroges*, now *Geneva*.

**Gergovia**: Lat. 44°-46° N., Long. 2°-4° E.; 6; VII. 4, 34, 36, 37, 38, 40, 41, 42, 43, 45, 59. A town of the *Arverni*. The plateau on which it was built is level, almost quite rectangular, and, being at an elevation of 761 metres above the sea, is visible at a considerable distance.

**Germáni**: I. 1, 2, 27, 28, 31, 33, 36, 39, 43, 44, 47, 48, 49, 50, 51, 52; II. 1, 3, 4; III. 7, 11; IV. 1, 2, 3, 4, 6, 7, 13, 14, 15, 16, 19; V. 2, 27, 28, 29, 41, 55; VI. 2, 5, 7, 8, 9, 12, 21, 24, 29, 32, 35, 37, 41, 42; VII. 13, 63, 65, 67, 70, 80. The people of *Germania*, *q. v.*

**Germania**: maps 1, 4; IV. 4; V. 13; VI. 11, 24, 25, 31; VII. 65. The Romans applied the name *Germania* to the whole country between the Rhine, the Danube, the Vistula, and the North Sea.

**Germáni (Transrhenáni)**: IV. 16; V. 2; VI. 5. The Germans on the German side of the Rhine.

**Gorgobina**: Lat. 46°-48° N., Long. 2°-4° E.; 6; VII. 9. A town of the *Boii*, in the land of the *Haedui*, founded by the *Boii* who emigrated with the Helvetians.

**Graioceli**: Lat. 44°-46° N., Long. 6°-8° E.; 2, 6; I. 10. A tribe in the Alps. Their chief town was *Ocelum*.

**Grudii**: Lat. 50°-52° N., Long. 2°-4° E.; 4; V. 29. A Belgic tribe, clients of the *Nervii*.

**Haedni**: Lat.  $46^{\circ}$ - $48^{\circ}$  N., Long.  $4^{\circ}$  E.; 2, 6; I. 3, 9, 10, 11, 14, 15, 16, 17, 18, 19, 23, 28, 31, 32, 33, 35, 36, 37, 43, 44, 48; II. 5, 10, 14, 15; V. 6, 7, 54; VI. 4, 11, 12; VII. 5, 9, 10, 17, 32, 33, 34, 37, 38, 39, 40, 41, 42, 43, 45, 48, 50, 53, 54, 55, 58, 61, 63, 64, 67, 76, 77, 89, 90. A powerful Celtic tribe allied with Rome.

**Harūdes**: Lat.  $48^{\circ}$ - $50^{\circ}$  N., Long.  $8^{\circ}$ - $10^{\circ}$  E.; I. 31, 37, 51. A German tribe, the remnant of the great Cimbric migration of the close of the second century B.C.

**Helvetii**: Lat.  $46^{\circ}$ - $48^{\circ}$  N., Long.  $6^{\circ}$ - $8^{\circ}$  E.; 2, 6; I. 1, 2, 3, 4, 5, 6, 7, 8, 9, 10, 11, 12, 13, 14, 15, 16, 17, 18, 19, 22, 23, 24, 25, 26, 27, 28, 29, 30, 31, 40; IV. 10; VI. 25; VII. 75. The Helvetians, a tribe between Lake Lemman (Geneva), the Rhone and the Rhine; the ancient Swiss.

**Helvii**: Lat.  $44^{\circ}$ - $46^{\circ}$  N., Long.  $4^{\circ}$ - $6^{\circ}$  E.; 2, 6; VII. 7, 8, 64, 65. A Gallic tribe in the Province.

**Hercynia (Silva)**: Lat.  $48^{\circ}$ - $50^{\circ}$  N., Long.  $8^{\circ}$ - $10^{\circ}$  E.; VI. 24, 25. The great Hercynian forest in Germany.

**Hibernia**: Ireland.

**Hispāni**: V. 26. The Spaniards.

**Hispania**: I. 1; III. 23; V. 1, 13, 27, 55. Spain.

**Illyricum**: II. 35; III. 7; V. 1. Illyria, the country east of the Adriatic, and west of Macedonia and Thrace. It reached to **Gallia Cisalpina**, and was one of Cæsar's provinces.

**Insula Batavorum**: see **Batavorum Insula**.

**Italia**: I. 10, 33, 40; II. 29, 35;

III. 1; V. 1, 29; VI. 1, 32, 44; VII. 1, 6, 7, 55, 57, 65. Italy.

**Itius Portus**: Lat.  $50^{\circ}$ - $52^{\circ}$  N., Long.  $0^{\circ}$ - $2^{\circ}$  E.; 4, 5; V. 2, 5. The port in Gaul from which Cæsar sailed on his second expedition to Britain. According to Napoleon III. it was the port of *Boulogne*. Göler thinks it was *Calais*.

**Jura (Mons)**: Lat.  $46^{\circ}$ - $48^{\circ}$  N., Long.  $6^{\circ}$  E.; 2, 6; I. 2, 6, 8. Mount Jura, the mountain chain dividing the **Sequani** from the Helvetians.

**Latobrigi**: Lat.  $48^{\circ}$ - $50^{\circ}$  N., Long.  $8^{\circ}$  E.; 4; I. 5, 28, 29. A German tribe.

**Lemānus Lacus**: Lat.  $46^{\circ}$ - $48^{\circ}$  N., Long.  $6^{\circ}$ - $8^{\circ}$  E.; 2, 6; I. 2, 8; III. 1. Lake *Leman*, or *Geneva*.

**Lenovices**: Lat.  $44^{\circ}$ - $46^{\circ}$  N., Long.  $0^{\circ}$ - $2^{\circ}$  E.; VII. 4, 75 (p. 180, l. 2), 88. A Celtic tribe. *Also* Lat.  $46^{\circ}$ - $48^{\circ}$  N., Long.  $0^{\circ}$ - $2^{\circ}$  W.; VII. 75 (p. 180, l. 10). An Armoric tribe. This latter is a doubtful reading.

**Lepontii**: Lat.  $46^{\circ}$ - $48^{\circ}$  N., Long.  $8^{\circ}$ - $10^{\circ}$  E.; IV. 10. A Celtic tribe.

**Leuci**: Lat.  $48^{\circ}$ - $50^{\circ}$  N., Long.  $6^{\circ}$  E.; 2, 4, 6; I. 40. A Celtic tribe.

**Levacl**: Lat.  $50^{\circ}$ - $52^{\circ}$  N., Long.  $2^{\circ}$ - $4^{\circ}$  E.; 4; V. 39. A Belgic tribe, clients of the **Nervii**.

**Lexovii**: Lat.  $48^{\circ}$ - $50^{\circ}$  N., Long.  $0^{\circ}$ ; 4; III. 9, 11, 17, 29; VII. 75. An Armoric tribe.

**Liger**: Lat.  $46^{\circ}$ - $48^{\circ}$  N., Long.  $0^{\circ}$ - $2^{\circ}$  W.; 2, 6; III. 9; VII. 5, 11, 55, 56, 59. The River *Loire*.

**Lingones**: Lat.  $46^{\circ}$ - $48^{\circ}$  N., Long.  $4^{\circ}$ - $6^{\circ}$  E.; 2, 4, 6; I. 26, 40; IV. 10; VI. 44; VII. 9, 63, 66. A Celtic tribe.

**Lutetia**: Lat. 48°-50° N., Long. 2°-4° E.; 3, 4, 6; VI. 3; VII. 57, 58. The chief town of the **Parisii**; now *Paris*.

**Magetobri(g)a**: I. 31. A Celtic town, at which Ariovistus defeated the Gauls.

**Mandubii**: Lat. 46°-48° N., Long. 4° E.; 2, 6; VII. 68, 71, 78. A Celtic tribe.

**Marcomanni**: Lat. 48°-50° N., Long. 8° E.; I. 51. A German tribe with Ariovistus.

**Matisco**: Lat. 46°-48° N., Long. 4°-6° E.; 2, 6; VII. 90. A town of the **Haedui**, now *Macon*.

**Matrona**: Lat. 48°-50° N., Long. 4° E.; 3, 4, 6; I. 1. The River *Marne*.

**Mediomatrici**: Lat. 48°-50° N., Long. 6°-8° E.; 2, 4; IV. 10; VII. 75. A Gallic tribe.

**Meldi**: Lat. 48°-50° N., Long. 2°-4° E.; 3, 4, 6; V. 5. A Celtic tribe.

**Melodunum**: Lat. 48°-50° N., Long. 2°-4° E.; 4, 6; VII. 58, 60, 61. A town of the **Senones**, on an island in the Seine; now *Melun*.

**Menapii**: Lat. 50°-52° N., Long. 4°-6° E.; 4; II. 4; III. 9, 28; IV. 4, 22, 38; VI. 2, 5, 6, 9, 33. A Belgic tribe.

**Mona**: Lat. 52°-54° N., Long. 4°-6° W.; V. 13. The Isle of Anglesey, off the coast of Britain.

**Morini**: Lat. 50°-52° N., Long. 2° E.; 3, 4, 5; II. 4; III. 9, 28; IV. 21, 22, 37, 38; V. 24; VII. 75, 76. A Belgic tribe.

**Mosa**: Lat. 50°-52° N., Long. 4°-6° E.; 4; IV. 9, 10, 12, 15, 16; V. 24; VI. 33. The River *Meuse*.

**Nannētes**: Lat. 46°-48° N., Long. 0°-2° W.; III. 9. A Celtic tribe.

**Nantuātes**: Lat. 46° N., Long. 6°-8° E.; 2; III. 1, 6; IV. 10. A Celtic tribe.

**Narbo (Narbo Martius)**: Lat. 42°-44° N., Long. 2°-4° E.; III. 20; VII. 7. A Roman colony in the Province; now *Narbonne*.

**Nemētes**: Lat. 48°-50° N., Long. 8° E.; 4; I. 51; VI. 25. A German tribe.

**Nervii**: Lat. 50°-52° N., Long. 4° E.; 3, 4; II. 4, 15, 16, 17, 19, 23, 28, 29, 32; V. 24, 38, 39, 41, 42, 45, 46, 48, 56, 58; VI. 2, 3, 29; VII. 75. A powerful Belgic tribe.

**Nitrobriges**: Lat. 44°-46° N., Long. 0°-2° E.; VII. 7, 31, 46, 75. A tribe of Aquitania.

**Noreia**: I. 5. A town in Styria.

**Noricum (Agrum)**: I. 5. The territory of Noreia, *q. v.*

**Noviodūnum**: 1. Noviodunum (Haeduorum). Lat. 46°-48° N., Long. 2°-4° E.; 6; VII. 55. A town of the **Haedui**. — 2. Noviodunum (Suessionum). Lat. 48°-50° N., Long. 4° E.; 3, 4, 6; II. 12. A town of the **Suessiones**; now *Soissons*. — 3. Noviodunum (Biturigum). Lat. 46°-48° N., Long. 2°-4° E.; VII. 12, 14. A town of the **Bituriges**.

**Oceanus**: I. 1; II. 34; III. 3, 7, 9; IV. 10, 29; VI. 31, 33; VII. 4, 75. The Atlantic.

**Ocelum**: Lat. 44°-46° N., Long. 6°-8° E.; 2; I. 10. A town of the **Graioceli**.

**Octodūrus**: Lat. 46°-48° N., Long. 6°-8° E.; 2; III. 1. A town of the **Veragri**.

**Orcynia**: VI. 24. A Greek name for the Hercynian forest.

**Osismi**: Lat. 48°-50° N., Long. 4° W.; II. 34; III. 9; VII. 75. An Armoric tribe.

**Padus**: V. 24. The River Po, in Northern Italy (Cisalpine Gaul).

**Paemāni**: Lat. 50° N., Long. 6° E.; 4; II. 4. A Belgic tribe of German descent.

**Parisii**: Lat. 48°-50° N., Long. 2° E.; 3, 4, 6; VI. 3; VII. 4, 34, 57, 75. A Celtic tribe. Their chief town, **Lutetia** (*mud* town?), became the modern *Paris*, from the name of the tribe.

**Petrocorii**: Lat. 44°-46° N., Long. 0°-2° E.; VII. 75. A tribe of Aquitania.

**Pictones**: Lat. 46°-48° N., Long. 0°; VII. 4, 75. A Celtic tribe.

**Pirustae**: V. 1. A tribe of Illyria.

**Pleumoxii**: Lat. 50°-52° N., Long. 4° E.; 4; V. 39. A Belgic tribe, clients of the *Nervii*.

**Provincia (Romana)**: I. 1, 2, 6, 7, 8, 10, 14, 15, 19, 28, 33, 35, 44, 45, 53; II. 29; III. 2, 6, 9, 20; V. 1; VI. 24; VII. 1, 6, 7, 55, 56, 59, 64, 65, 66, 77. Transalpine Gaul, especially as it was at the beginning of Cæsar's proconsulate. Hence the modern *Provence*.

**Pyrenaei Montes**: Lat. 42°-44° N., Long. 2° W.; I. 1. The Pyrenees.

**Ptiani**: Lat. 44°-46° N., Long. 0°-2° E.; III. 27. A tribe of Aquitania.

**Rauraci**: Lat. 46°-48° N., Long. 6°-8° E.; 2, 4; I. 5, 29; VI. 25; VII. 75. A German tribe.

**Remi**: Lat. 48°-50° N., Long. 4°-6° E.; 3, 4, 6; III. 13, 14; IV. 25; V. 8; VII. 60, 61, 90. A powerful Belgic tribe.

**Rhenus**: Lat. 50°-52° N., Long. 6°-8° E.; 2, 3; I. 1, 2, 5, 27, 28, 31, 33, 35, 37, 43, 44, 53, 54; II. 3, 4, 29, 35; III. 11; IV. 1, 3, 4, 6, 10, 14, 15, 16, 17, 19; V. 3, 24, 27, 29, 41, 55; VI. 9, 24, 29, 32, 35, 41, 42; VII. 65. The River *Rhine*.

**Rhodanus**: Lat. 44°-46° N., Long. 4°-6° E.; 2, 6; I. 1, 2, 6, 8, 10, 11, 12, 33; III. 1; VII. 65. The River *Rhone*.

**Roma**: I. 31; VI. 12; VII. 90. The city of Rome.

**Rutēni**: Lat. 44° N., Long. 2° E.; 6; I. 45; VII. 5, 7, 64, 75, 90. A Celtic tribe bordering on the Province.

**Sabis**: Lat. 50°-52° N., Long. 4° E.; 3, 4; II. 16, 18. The River *Sambre*, an affluent of the *Meuse*.

**Samarobriva**: Lat. 48°-50° N., Long. 2°-4° E.; 3, 4, 5; V. 24, 47, 53. The chief town of the *Ambiāni*; now *Amiens*.

**Santones** (or *Santoni*): Lat. 46° N., Long. 0°-2° W.; I. 10, 11; III. 11; VII. 75. A Celtic tribe.

**Scaldis**: Lat. 50°-52° N., Long. 2°-4° E.; VI. 33. The River *Scheldt*.

**Sedūni**: Lat. 46°-48° N., Long. 8° E.; 2; III. 1, 2, 7. A tribe of the Alps.

**Sedusii**: Lat. 48°-50° N., Long. 8°-10° E.; I. 51. A German tribe.

**Segni**: Lat. 50°-52° N., Long. 4°-6° E.; 4; VI. 32. A Belgic tribe.

**Segontiaci**: Lat. 50°-52° N., Long. 0°-2° W.; V. 21. A tribe of Britain.

**Segusiāvi**: Lat. 46° N., Long. 4° E.; 2, 6; I. 10; VII. 64, 75. A Celtic tribe.

**Senones**: Lat. 48°-50° N., Long. 2°-4° E.; 2, 3, 4, 6; II. 2; V. 54, 56; VI. 2, 3, 5, 44; VII. 4, 7, 11, 34, 56, 58, 75. A powerful Celtic tribe.

**Sequana**: Lat. 48°-50° N., Long. 2° E.; 2, 3, 4, 6; I. 1, 9; VII. 57, 58. The River *Seine*.

**Sequani**: Lat. 46°-48° N., Long. 6° E.; 2, 6; I. 1, 2, 3, 6, 8, 9, 10, 11, 12, 19, 31, 32, 33, 35, 38, 40, 44, 48, 54; IV. 10; VI. 12; VII. 66, 67, 75, 90. A Celtic tribe.

**Sibuzātes**: Lat. 42°-44° N., Long. 0°-2° W.; III. 27. A tribe of Aquitania.

**Sontiātes**: Lat. 44°-46° N., Long. 0°-2° E.; III. 20, 21. A tribe of Aquitania.

**Suessiōnes**: Lat. 48°-50° N., Long. 2°-4° E.; 3, 4, 6; II. 3, 4, 12, 13. A Belgic tribe.

**Suēvi**: Lat. 50°-52° N., Long. 8°-10° E.; I. 37, 51, 54; IV. 1, 3, 4, 7, 8, 16, 19; VI. 9, 10. A powerful German people; the *Suabians*.

**Sugambri**: Lat. 50°-52° N., Long. 8° E.; 4; IV. 16, 18, 19; VI. 35. A German tribe.

**Tamesis**: Lat. 50°-52° N., Long. 0°-2° W.; 4, 5; V. 11, 18. The River *Thames*.

**Tarbelli**: Lat. 44° N., Long. 0°-2° W.; III. 27. A tribe of Aquitania.

**Tarusātes**: Lat. 44°-46° N., Long. 0°-2° W.; III. 23, 27. A tribe of Aquitania.

**Tectosages**: Lat. 42°-44° N., Long. 2° E.; VI. 24. See *Volcae*.

**Tenctēri**: Lat. 50°-52° N., Long. 6°-8° E.; 4; IV. 1, 4, 16, 18; V.

55; VI. 35. A German tribe. See *Usipetes*.

**Teutones** (or *Teutoni*): I. 33, 40; II. 29; III. 4; VII. 77. A great German people who invaded Gaul in company with the *Cimbri*, near the close of the second century B.C.; defeated by Marius, B.C. 102, at *Aquae Sextiae* (*Aix*).

**Tolōsa**: Lat. 42°-44° N., Long. 0°-2° E.; III. 20. A city of the *Volcae Tectosages*; now *Toulouse*.

**Tolosātes**: I. 10; VII. 7. The people of *Tolosa* (*Toulouse*).

**Transalpīna** (*Gallia*): see *Gallia Transalpīna*.

**Transrhenāni** (*Germani*): see *Germani Transrhenani*.

**Treveri**: Lat. 50° N., Long. 6° -8° E.; 4; I. 37; II. 24; III. 11; IV. 6, 10; V. 2, 3, 4, 24, 26, 47, 53, 55, 58; VI. 2, 3, 5, 6, 7, 8, 9, 29, 32, 44. A German tribe settled in Belgic Gaul.

**Triboci** (or *Triboces*): Lat. 48° -50° N., Long. 8° E.; 4; I. 51; IV. 10. A German tribe.

**Trinobantes**: Lat. 52° N., Long. 0°-2° E.; 5; V. 20, 21, 22. A tribe in Britain.

**Tulingi**: Lat. 46°-48° N., Long. 8° E.; I. 5, 25, 28, 29. A German tribe.

**Turones** (or *Turoni*): Lat. 46° -48° N., Long. 0°; II. 35; VII. 4, 75. A Celtic tribe.

**Ubi**: Lat. 50°-52° N., Long. 6°-8° E.; 4; I. 54; IV. 3, 8, 11, 16, 19; V. 9; VI. 9, 10, 29. A German tribe.

**Unelli**: Lat. 48°-50° N., Long. 0°-2° W.; II. 34; III. 11, 17; VII. 75. An Armorican tribe.

**Usipetes**: Lat. 52°-54° N., Long.

6°-8° E.; 4; IV. 1, 4, 16, 18; VI. 35. A German tribe.

**Vacalus** (or **Vahalis**): Lat. 50°-52° N., Long. 6° E.; 4; IV. 10. The *Waal*, a branch from the Rhine, that empties into the Meuse.

**Vahalis**: see **Vacalus**.

**Vaugiones**: Lat. 48°-50° N., Long. 8° E.; 4; I. 51. A German tribe.

**Vellaunodūnum**: Lat. 48°-50° N., Long. 2°-4° E.; 6; VII. 11, 14. A town of the **Senones**.

**Vellavii** (or **Vellavi**): Lat. 44°-46° N., Long. 4° E.; 2, 6; VII. 75. A Celtic tribe.

**Vellocasses** (or **Velioeasses**): Lat. 48°-50° N., Long. 2° E.; 4; II. 4; VII. 75. An Armoric tribe.

**Veneti**: Lat. 48° N., Long. 4° W.; II. 34; III. 7, 8, 9, 11, 16, 17, 18. A powerful Armoric tribe.

**Venetia**: III. 9. The country of the **Veneti**.

**Veragri**: Lat. 46°-48° N., Long. 6°-8° E.; 2; III. 1, 2. A Celtic tribe of the Alps.

**Verbigenus**: I. 27. A canton of the **Helvetii**.

**Veromandui**: Lat. 50°-52° N., Long. 4° E.; 4; II. 4, 16, 23. A Belgic tribe.

**Vesontio**: Lat. 46°-48° N., Long. 4°-6° E.; 2, 6; I. 38, 39. The chief town of the **Sequani**; now *Besançon*.

**Vienna**: Lat. 44°-46° N., Long. 4°-6° E.; 2, 6; VII. 9. A town of the **Allobroges**.

**Vocātes**: Lat. 44°-46° N., Long. 0°-2° W.; III. 23, 27. A tribe of Aquitania.

**Vocontii**: Lat. 44°-46° N., Long. 4°-6° E.; 2, 6; I. 10. A tribe of the Province.

**Volcae**: Lat. 44° N., Long. 2°-4° E.; 6; VI. 24; VII. 7, 64. A powerful tribe in the Province. There were two divisions: 1. The **Volcae Tectosages**. 2. The **Volcae Arecomici**.

**Vosegus**: Lat. 48°-50° N., Long. 6°-8° E.; 2, 4, 6; IV. 10. The *Vosges Mts.*



A SPECIAL

VOCABULARY TO CÆSAR,

*COVERING SEVEN BOOKS.*

---

By J. B. GREENOUGH.

---

BOSTON :  
PUBLISHED BY GINN & COMPANY.  
1889.

---

*Copyright by J. B. Greenough, 1885.*



# VOCABULARY.

**A., Aulus** (wh. see).

**a. d., ante diem** (wh. see).

**ā, see ab.**

**ab** (*ā, abs*), [reduced case of unc. stem akin to Gr. ἀπό, Eng. *off, of*], adv. (only in comp.), and prep. with abl., *away from, from* (cf. **ex, out of**).—Of place, with idea of motion, *from*: **ab Arare iter convertere**.—Of time, **ab hora quarta**.—Fig., *from*, with more or less feeling of motion: **ab cohortatione profectus**; **temperare ab injuriis**; **tutus ab**; **ab ramis** (*from the branches, as far as where they begin*).—With expressions of measure, *off, away, at a distance of*: **a milibus passuum duobus** (*two miles off*).—With different notion in Eng., **ortum est ab** (*began with*); **vacuum ab** (*destitute of*); **capit initium a** (*begin at*); **ab tanto spatio** (*so far off*); **ab officio discedere** (*forsake, etc.*); **a quibus decedere** (*abandon, etc.*); **gratiam inire ab** (*secure gratitude from, win favor with*).—Esp. with passives and similar notions, *by*: **accidere a Caesare** (*at the hands of, showing the origin of this meaning*).—Esp. also (prob. as the place whence the impression comes), *on the side of, on, at, on the part of*: **a dextro cornu**; **a re frumentaria** (*in respect to*); **intritus ab labore** (*by*).—In comp., *away, off, apart*.—Also with negative force, *not, un-*.

**abditus**, p.p. of **abdo**.

**abdō, -didī, -ditus, -dere**, [**ab-do** (*put*)], 3. v. a., *put away, remove, hide*.—With reflex., *conceal one's self, hide*.—With **in** and acc., *hide in, withdraw to (take refuge among), withdraw and hide away*.—**abditus, -a, -um, p.p.**, *hidden, remote*: **abditi in tabernaculis** (*secluding themselves, etc.*).

**abdūcō, -duxī, -ductus, -dūcere**, [**ab-duco**], 3. v. a., *lead away, draw away, take away, lead off, carry away* (of persons or things which move of themselves).

**abeō, -iī, -itūrus, -ire**, [**ab-eo**], irr. v. n., *go away, go off, retire, go* (out of sight or away).

**abiciō, -jēcī, -jectus, -icere**, [**ab-jacio**], 3. v. a., *throw away, throw down, throw* (away from one's self).

**abiēs, -ietis** (-jetis), [?], F., *fir* or *spruce* (tree or wood), (prob. including all short-leaved coniferæ).

**abjectus**, p.p. of **abicio**.

**abjiciō**, see better spelling **abicio**.

**abjunctus**, p.p. of **abjungo**.

**abjungō, -junxī, -junctus, -jungere, [ab-jungo]**, 3. v. a., *disjoin, detach*: **abjuncto Labieno**.

**abripīō, -ripuī, -reptus, -ripere, [ab-rapio]**, 3. v. a., *carry off* (with violence), *drag away*.

**abs, see ab.**

**abscīdō, -cīdī, -cīsus, -cīdere, [abs-caedo]**, 3. v. a., *cut off, lop off, tear off, tear away*.

**abscisus**, p.p. of **abscido**.

**absēns**, see **absum**.

**absimilis**, -e, [**ab-similis**], adj., *unlike*.

**absistō**, -stitī, no p.p., -sistere, [**ab-sisto**], 3. v. n., *stand away, withdraw*. — Fig., *leave off, keep aloof*.

**abstineō**, -tinuī, -tentus, -tinēre, [**abs-teneo**], 2. v. n., *hold (one's self) off*. — Fig., *refrain, spare*: **proelio** (*refrain from giving*); **mulieribus** (*spare*).

**abstrāctus**, p.p. of **abstraho**.

**abstrahō**, -traxī, -trāctus, -trahere, [**abs-traho**], 3. v. a., *drag off, drag away*.

**absum**, -fui (āfui), -futūrus, -esse, [**ab-sum**], irr. v. n., *be away, be absent, be off* (at a distance). — Fig., **suspicio** (*be wanting*); **nomen** (*be far from helping*); **ab eo quin** (*be far from being*); **multum quin** (*lack much of, etc.*); **longius quin** (*be farther off... that*); **a bello** (*keep aloof*); **ab hoc consilio** (*not be concerned in*). — **absens**, p. as adj., *absent, in one's absence*.

**abundō**, -āvi, -ātūrus, -āre, [**ab-undō**], 1. v. n., *overflow*. — Fig., *abound*. — Transf. (of the place, etc., containing the thing), *be strong in, be rich in, abound in*.

**āc**, shorter form for **atque** (wh. see).

**accēdō**, -cēssi, -cēssūrus, -cēdere, [**ad-cedo**], 3. v. n., *move towards, draw near, approach, come up, come (to), advance to, advance*. — Fig., *come to*: **Remis studium** (*be inspired in, cf. discedo*). — Esp., *be added*, where often an explanatory word is necessary in Eng.: **huc accedere** (*be in addition to this*); **huc accedebat ut** (*there was also this disadvantage*); so with **quod** (*there*

*was also the fact that, there was also the reason that, or simply moreover, then again*).

**accelerō**, -āvi, -ātus, -āre, [**ad-celero**], 1. v. a. and n., *hasten*.

**acceptus**, p.p. of **accipio**.

**accersō**, see **arcesso**.

**accēssus**, p.p. of **accedo**.

**accidō**, -cidi, no p.p., -cidere [**ad-cado**], 3. v. n., *fall upon, fall*. **tela gravior** (*strike*). — Fig., *happen, occur, present itself, turn out, arise*. — Often euphemistically for death, defeat, etc.: **si quid Romanis**; **gravior a Caesare** (*be done, severe measures be taken*).

**accidō**, -cidi, -cīsus, cīdere, [**ad-caedo**], 3. v. a., *cut into, partly cut*.

**accipiō**, -cēpi, -ceptus, -cipere, [**ad-capio**], 3. v. a., *take, receive*: **exercitum** (*take command of*). — Less exactly, **volnus**; **incommodum** (*suffer, meet with*). — Fig., *accept, learn, hear, get, take*: **excusationem**; **usus** (*acquire*); **aliquid fama** (*hear of*). — **acceptus**, -a, -um, p.p. as adj., *acceptable*.

**acclivis**, -e, [**ad-clivus** (weakened)], adj., *rising, sloping, ascending*: **collis**; **aditus**.

**acclivitas**, -tātis, [**acclivi + tas**], F., *slope, inclination*: **par** (*steepness*).

**Accō**, -ōnis, [Celtic], M., one of the Senones, who stirred up his people against the Romans. The revolt was suppressed by Cæsar's sudden arrival, and Acco was tried and condemned to death.

**accommodātus**, p.p. of **accommodo**.

**accommodō**, -āvi, -ātus, -āre, [**ac-commodō**, or **ad-commodo**], 1. v. a., *fit on, fit*: **insignia** (*put on, adjust*). — **accommodātus**, -a, -um, p.p., *fitted, adapted*.

**accūrātē** [abl. of **accuratus**], adv., *with care, carefully.*

**accurrō**, -curri (-cucurri), no p.p., -currere, [ad-curro], 3. v. n., *run to, run up (on foot), rush up (on horseback), ride up.*

**accūsō**, -āvi, -ātus, -āre, [ad-+causo (cf. **causor**)], *accuse, blame, find fault with.*

**ācer**, -cris, -cre, [√AC (cf. **acus**) + ris (cf. -rus in **purus**)], adj., *sharp.* — Fig., *keen, active, violent.*

**acerbē** [abl. of **acerbus**], adv., *bitterly.* — Fig. (of the mind), *ferre inopiam (suffer severely from, etc.).*

**acerbitās**, -tātis, [acerbō + tas], F., *bitterness.* — Concrete in plur., *sufferings (with a change of point of view in Eng.).*

**acerbus**, -a, -um, [**acer** (treated as stem) + **bus** (cf. **superbus**)], adj., *bitter (to the taste).* — Fig. (to the mind), *bitter, hard to bear, cruel.*

**ācerrimē** (**acerrime**), superl. of **ācriter**.

**acervus**, -ī, [**acer** (as stem) + **vus** (cf. **torvus**)], M., (*pointed?*), *a heap, a pile.*

**aciēs**, -ēi, [√AC + ies (cf. **series**)], F., *point, sharp edge, edge: oculorum (keen glance, glare).* — Esp., *line, battle line, array, army (in battle array, cf. **agmen**), rank (of an army in several ranks).* The battle array of the Romans in Cæsar's time was generally in three lines, though each *line* was about ten soldiers deep. The line was not continuous, but the cohorts were separated by a space equal to their front, and behind these spaces stood the cohorts of the next *line*: *acie instructa depugnare (fight a pitched battle).*

**acquirō**, see **adquiro**.

**ācriter** [acrō + ter (prob. neut.

of -terus reduced, cf. **alter**)], adv., *sharply.* — Fig., *fiercely, violently, hotly (of fighting), with spirit.*

**āctuarius**, -a, -um, [actu + arius], adj., *fast sailing (provided with sails and oars both).*

**āctus**, p.p. of **ago**.

**acuō**, -uī, -ūtus, -uere, [acu- (stem of **acus**)], 3. v. a., *sharpen.* — **acūtus**, -a, -um, p.p. as adj., *sharpened, sharp.*

**acūtus**, p.p. of **acuō**.

**ad** [?], adv. (only in comp.), and prep. with acc. With idea of motion, *to, towards, against.* — Where the idea of motion is more or less obliterated, *to, towards, for, at, on, against, in, in regard to.* — Of time, *till, at, on.* — With numerals, *about.* — Esp., *deferre ad (lay before); recepti ad se (among); ad fortunam Cæsari defuit (Cæsar lacked to complete, etc.); contendere ad occupandam (to), (and often with the gerund construction); ad certum pondus (of); ad modum (in); commeare ad (visit); ad impedimenta (by); ad auxilium (to give assistance); ad arbitrium (according to); proficisci ad (for); ad unum (to a man); ad celeritatem (in the way of).* — In comp., *to, in, by, towards.*

**adāctus**, p.p. of **adigo**.

**a. d.**, see **autē**.

**adaequō**, -āvi, -ātus, -āre, [ad-aequo], 1. v. a., *make equal to: moles moenibus (make as high as).* — More commonly with the verb neuter and the acc. or dat. depending on combined idea, *become equal to, equal: altitudinem muri (reach up to); cursum (keep up with).*

**adamō**, -āvi, -ātus, -āre, [ad-amo], 1. v. a., *fall in love with, take a fancy to, covet.*

**adangeō**, -anxi, -anctus, -angere, [ad-angeo], 2. v. a., *increase*.

**addō**, -didī, -ditus, -dere, [ad-do 1 and 2)], 3. v. a., *give to*. — Also, *place to, add* (with acc. or absolutely).

**adducō**, -duxī, -ductus, -ducere, [ad-duco], 3. v. a., *lead to, draw to, bring in* (of persons), *bring, draw in* (towards one), *drive, force*. — Fig., *induce, drive*.

**adductus**, p.p. of *adduco*.

**ademptus**, p.p. of *adimo*.

1. **adeō**, -iī (-ivī), -iturus, -īre, [ad-eō], irr. v. a. and n., *go to, visit, get at, come to, come up, go to* (a place), *get in* (to a place), *advance* (somewhere), *attack, approach* (speak with): *ad* (*come into the presence of*).

2. **adeō** [ad-eō], adv., *to that point*. — Less exactly, *to that degree, so much, so*: **discessisse adeo ut** (*so speedily that*). — Weakened, *in fact, at all, exactly*.

**adeptus**, p.p. of *adipiscor*.

**adequitō**, -āvī, no p.p., -āre, [ad-equito], 1. v. a. and n., *ride up, ride against, skirmish with* (of cavalry).

**adfectus**, p.p. of *adfacio*.

**adferō** (aff-), -tulī, -lātus, -ferre, [ad-fero], irr. v. a., *bring to, bring*: *litteras*. — Fig., *cause, bring forward, allege, report, announce*: *fortuna casus* (*bring about*).

**adfaciō** (aff-), -fēcī, -fectus, -ficere, [ad-facio], 3. v. a., *do to, affect*. — With acc. and abl., *affect with, inflict upon, produce in, cause to, visit with, fill with*. — In passive, *suffer, receive, be in* (a condition), *be afflicted by, suffer from*: **beneficio adfectus** (*having received favors*).

**adfigō**, -fixī, -fixus, -figere, [ad-figo], 3. v. a., *fasten to* (by insertion).

**adfingō**, -finxī, -fictus, -fingere,

[ad-fingo], 3. v. a., *make up in addition*. — Of rumors, *invent more*.

**adfinitās** (aff-), -tātis, [adfīni + tas], F., *nearness*. — Of relation by marriage, *relationship, alliance, connection*. — Concretely, *a connection*: **adfinitatibus coniuncti** (*marriages*).

**adfirmātiō** (aff-), -ōnis, [ad-firmatio (cf. *adfirmo*)], F., *assurance*. — Concretely, *an assertion*.

**adfixus** (aff-), p.p. of *adfigo*.

**adflictō** (aff-), -āvī, -ātus, -āre, [ad-flicto, cf. *adfligo*], 1. v. a., *dash against, dash upon, dash to the ground*. Hence, *overthrow, overwhelm, wreck*.

**adflictus** (aff-), p.p. of *adfligo*.

**adfligō** (aff-), -flīxī, -flictus, -fligere, [ad-fligo], 3. v. a., *dash upon*. Hence, *overthrow, wreck, overturn*: **naves** (*shatter, damage*); **arbores** (*throw down*).

**adfore** (aff-), see *adsum*.

**adgredior** (agg-), -gressus, -gredi, [ad-gradior], 3. v. dep., *go towards, go to, march against, attack*.

**adgregō** (agg-), -āvī, -ātus, -āre, [ad-gregō], 1. v. a., *unite in a flock, gather*: **se** (*gather around, flock to*); **se ad amicitiam** (*attach one's self to*).

**adhaereō**, -haesī, -haesūrus, -haerere, [ad-haereo], 2. v. n., *stick (to), cling (to), get caught (in)*.

**adhaerescō**, -ere, [ad-haeresco], 3. v. n., same as *adhaereo*.

**adhabeō**, -uī, -itus, -ere, [ad-habeo], 2. v. a., *have in*. Hence, *call in, admit, bring with* (one). — Fig., *employ, use*.

**adhibitus**, p.p. of *adhibeo*.

**adhortor**, -ātus, -ārī, [ad-hortor], 1. v. dep., *encourage, address, urge, rally* (soldiers).

**adhūc** [ad-huc], adv., *hitherto* (of place). — Of time, *up to this time, till now, to this day*.

**Adiatunnus**, -ī, [Celtic], M., chief of the Sontiates.

**adiciō** (adjic-), -jēcī, -jectus, -icere, [ad-jacio], 3. v. a., *throw to*: *telum adici* (*reach*); *aggerem* (*throw up*). — Fig., *add*: *adjecta planities* (*with the addition of*).

**adigō**, -ēgī, -actus, -igere, [ad-ago], 3. v. a., *drive to, drive up* (of cattle). — Less exactly, *drive in* (of piles), *move up* (of towers), *shoot* (of weapons). — Fig., *force, bind* (by oath).

**adimō**, -ēmī, -emptus, -imere, [ad-emo] (*take*), 3. v. a., *take away* (the action being looked upon as done to somebody). — Fig., *destroy, cut off*: *spem*; *prospectum* (*intercept, cut off*).

**adipiscor**, -eptus, -ipiscī, [ad-apiscor], 3. v. dep., *obtain, secure*: *victoriam* (*win, gain*).

**aditus**, -ūs, [ad-itus, cf. adeo] (1), M., *approach, arrival, coming, access*: *defugere* (*contact, intercourse*). — Concretely, *an avenue* (of approach), *access* (excuse for approaching), *means of approach, means of access, way of approach, approach* (in military sense). — Phrases: *sermonis* (*occasion for intercourse*); *ad uxorem* (*intercourse*).

**adjaceō**, -jaciū, no p.p., -jacēre, [ad-jaceo], 2. v. n., *lie near, border on, be adjacent*.

**adjectus**, p.p. of *adicio*.

**adjiciō**, see better spelling *adicio*.

**adjūdicātus**, p.p. of *adjudico*.

**adjūdicō**, -āvī, -ātus, -āre, [ad-judico], 1. v. a., *adjudge, assign* (by deliberation).

**adjungō**, -junxī, -junctus, -jun-

*gerc*, [ad-jungo], 3. v. a., *join to, unite to, attach, unite with*.

**adjūtor**, -tōris, [ad-†jutor, cf. adjuvo], M., *helper, assistant, abettor*.

**adjūtus**, p.p. of *adjuvo*.

**adjuvō**, -jūvī, -jūtus, -juvāre, [ad-juvo], 1. v. a., *assist, help, help on*. *be of advantage, be an assistance to* *ad spem* (*encourage*).

**adlātus** (all-), p.p. of *adfero*.

**adliciō** (all-), -lēxī, -lectus, -licere, [ad-lacio], 3. v. a., *allure to, invite, entice, attract*.

**Admagetobriga**, -ae, [Celtic], F., a town in Gaul where Ariovistus defeated the Gauls. Position uncertain.

**admātūrō**, -āvī, -ātus, -āre, [ad-maturo], 1. v. a., *hasten* (cf. *maturo*): *defectionem* (*bring to a head more quickly*).

**administer**, -trī, [ad-minister], M., *servant, minister*: *ad sacrificia* (*priest*).

**administrō**, -āvī, -ātus, -āre, [ad-ministro], 1. v. a., *carry into execution, perform, execute, carry out, carry on* (war), *attend to* (duties): *imperia* (*give, carry out the duties of a commander*).

**admirātus**, p.p. of *admiror*.

**admiror**, -ātus, -ārī, [ad-miror], 1. v. dep., *be surprised, wonder at, admire*. — **admirāndus**, -a, -um, as adj., *surprising*. — **admirātus**, -a, -um, p.p. in pres. sense, *being surprised*.

**admissus**, p.p. of *admitto*.

**admittō**, -mīsī, -missus, -mittere, [ad-mitto], 3. v. a., (*let go to*), *let go*: *admisso equo* (*at full speed*). — Fig., *allow* (cf. *com-* and *per-* *mitto*): *in se facinus* (*commit a crime*); *dedecus* (*permit to be incurred*). — Also pass. without *in se*, *be committed*.

**admodum** [ad modum], adv., *to a degree*. Hence, *very, very much, greatly, exceedingly, so (very) much*.

**admoneō**, -uī, -itus, -ēre, [ad-moneo], 2. v. a., *warn, urge*.

**adolēscēns**, see **adulescens**.

**adolēscēntia**, see **adulescēntia**.

**adolēscō**, -olēvī, -ultus, -olēscere, [ad-olesco], 3. v. n., *grow up (to maturity), mature*. See also **adulescens**.

**adorior**, -ortus, -ōriri, [ad-orior], 4. v. dep., (*rise up against*), *attack, assail*.

**adortus**, -a, -um, p.p. of **adorior**.

**adparō** (**app**-), -āvi, -ātus, -āre, [ad-paro], 1. v. a. and n., *prepare, get ready, make preparations*.

**adpellō** (**app**-), -pulī, -pulsus, -pellere, [ad-pello], 3. v. a. and n., *land (ships), bring to land*.

**adpetō** (**app**-), -petivī, -petitus, -petere, [ad-petō], 3. v. a. and n., *seek to gain, desire, aim at*. — Abs., *approach*.

**adplicō** (**app**-), -āvi (-uī), -plicātus (-plicitus), -plicare, [ad-plico], 1. v. a., (*bend towards*). With reflex., *lean against*.

**adportō**, -āvi, -ātus, -āre, [ad-porto], 1. v. a., *bring in, bring (to some place)*.

**adprobō**, -āvi, -ātus, -āre, [ad-probo], 1. v. a., *approve of, agree with (an opinion or action)*.

**adpropinquō**, -āvi, no p.p., -āre, [ad-propinquo], 1. v. n., *approach, come nearer, come near*.

**adpulsus**, p.p. of 1. **adpello**.

**adquirō** (**acq**-), -quīsivī, -quīsītus, -quīrere, [ad-quiroy], 3. v. a., (*get in addition*), *acquire*: **aliquid** (*gain some advantage*).

**adripiō** (**arr**-), -ripui, -reptus,

-ripere, [ad-rapio], 3. v. a., *snatch up, seize*.

**adroganter** [adrogant- (stem of p. of **adrogo**) + **ter**], adv., *with presumption, presumingly, with insolence*.

**adrogantia**, -ae, [adrogant- (see preceding) + **ia**], F., *insolence, insolent conduct, presumption*.

**adscendō** (**asc**-), -scendī, -scēnsus, -scendere, [ad-scando], 3. v. a. and n., *climb up, climb, ascend*: **valium** (*mount*).

**adscēnsus** (**asc**-), -ūs, [ad-†scanus, cf. **ascendo**], M., *a climbing up, an ascent, a going up*. — Concr., *a way up, a means of ascent*: **prohibere ascensu** (*from climbing up*).

**adsciscō**, -scivī, -scītus, -sciscere, [ad-scisco], 3. v. a., *attach (by formal decree)*. — Less exactly, *attach to (one's self), unite with (one's self)*.

**adsiduus** (**ass**-), -a, -um, [ad-†siduus (√SED + **uus**, cf. **residuus**)], adj., (*sitting by*), *constant, continued, incessant*.

**adsistō** (**ass**-), -stitī, no p.p., -sistere, [ad-sisto], 3. v. n., *stand by, attend, assist*: **in conspectu patris** (*appear*).

**adspectus** (**asp**-), -ūs, [ad-†spectus (cf. **adspicio**)], M., *a looking at*. — Transf., *an appearance, aspect*.

**adsuēfaciō** (**ass**-), -fēcī, -factus, -facere, [†adsuē- (unc. case, akin to **suesco**) -**facio**], 3. v. a., *accustom, train*. — Pass., *be accustomed*.

**adsuēfactus**, -a, -um, p.p. of **adsuēfacio**.

**adsuēscō** (**ass**-), -suēvī, -suētus, -suēscere, [ad-suesco], 3. v. a. and n., *accustom, become accustomed, become wonted (of animals)*.



**adsuētus**, -a, -um, pp. of **adsu-escō**.

**adsum** (**assum**), -fui, -futūrus, -esse, [ad-sum], irr. v. n., *be near, be by, be present, be at hand, be there, appear*.

**adtexō**, see **attexo**.

**adingō**, see **atingo**.

**adtribuō**, see **attribuo**.

**Aduātuca**, -ae, [Celtic], F., a fortress of the Eburones (prob. *Tongres*), near the Meuse.

**Aduātuci**, -ōrum, [Celtic], M. pl., a tribe of the Belgæ (originally Germans) living on the west bank of the Meuse (later, *Tongri*).

**adulēscēns**, -entis, [p. of **adulesco**], adj., *young*. — As noun, *a youth, young man*. — With proper names, *the younger* (Jr., to distinguish one from his father).

**adulēscēntia**, -ae, [adulescent- + ia], F., *youth*.

**adulēscēntulus**, -ī, [adulescent- (as if **adulescētō**-) + **lus**], M. (often as adj.), *a mere boy, very young*.

**adventus**, -ūs, [ad- + **ventus** (cf. **advenio** and **eventus**)], M., *a coming, arrival*.

**adversārius**, -a, -um, [adversō- (reduced) + **arius**, cf. **onerārius**], adj., (*turned towards*), *opposed*. — As noun, *opponent*.

**adversus**, p.p. of **adverto**, in various uses, wh. see.

**adversus**, prep., see **adverto**.

**advertō**, -verti, -versus, -vertere, [ad-vertō], 3. v. a., *turn towards*: **auimum** (*turn the attention, notice*, see **animadvertō**), *turn against, turn* (to anything). — **adversus**, -a, -um, p.p. as adj., *in front, opposed, opposite, in opposition, adverse*: **proelium** (*unsuccessful*); **nox** (*un-*

*favorable*); **hostibus adversis occurrebant** (*right against, in their front*); **in adversum os** (*right in*); **flumine** (*up*, cf. **secundo**); **res adversae** (*adversity, want of success*). — **adversus** [petrified as adv., cf. **versus**], *against*.

**advocō**, -āvī, -ātus, -āre, [ad-voco], 1. v. a., *call* (to one), *summon*.

**advolō**, -āvī, -ātūrus, -āre, [ad-volo], 1. v. n., *fly to, fly at*. — Less exactly, of cavalry, *rush at, fly at*.

**aedificium**, -ī, [†aedific- (cf. **artifex**) + **ium**], N., *building*. — Esp. standing singly, *opposed to vil-lages, farm houses*.

**aedificō**, -āvī, -ātus, -āre, [†aedific- (cf. **artifex**)], 1. v. a., *build* (of houses). — Less exactly, of ships.

**Aeduis**, etc., see **Haeduis**.

**aeger**, -gra, -grum, [unc. root (?√IG, *shake*) + **rus**], adj., *sick, disabled*.

**aegerrimē**, superl. of **aeger**.

**aegrē** [abl. of **aeger**], adv., *feebly*. Hence, *with difficulty, hardly, scarcely*.

**Aemilius**, -ī, [? aemulō- (reduced) + **ius**], M., (Lucius), a Gaul, a subaltern in Cæsar's Gallic cavalry. Prob. named from some Roman Aemilius from whom he had received the citizenship.

**aequāliter** [aequali + **ter** (cf. **acriter**)], adv., *evenly, uniformly*.

**aequinoctium**, -ī, [as if aequinoct- (as adj. stem) + **ium** (cf. **biennium**)], N., *the time of the equinox, the equinox*.

**aequitās**, -tātis, [aequō + **tas**], F., *evenness*. Hence (cf. **aequus**), *fairness, justice*. — Esp., *aequitas animi* (*evenness of mind, contentment, resignation*).

**aequō**, -āvi, -ātus, -āre, [aequō-],  
I. v. a., *make equal, equalize*.

**aequus**, -a, -um, [?, perh. akin to **unus**], adj., *even, level, equal*. Hence, *fair, just, equitable*. — Esp., **aequus animus** (*equanimity, contentment, resignation*); **aequo animo aliquid facere** (*be resigned to, be satisfied to, be content to*); **contentio** (*on equal terms*); **aequo Marte** (*on equal terms*).

**aerārius**, -a, -um, [aer- (as stem of **aes**) + **arius** (cf. **onerarius**)], adj., (*having to do with copper*). — Fem. as noun, *a mine*.

**aereus**, -a, -um, [aer- (as stem of **aes**) + **eus** (for -ayas)], adj., *of copper, copper* (as adj.).

**aes**, **aeris**, [perh. akin to Eng. *iron*], N., *copper* (for ships, or as money). Hence, *money*. — Esp., **alienum** (*debt, another man's money*).

**aestās**, -tātis, [stem akin to **aedes** + **tas**, or perh. **aestā-** (cf. **juventa**) + **tis** (cf. **virtus**)], F., (*heat*), *summer* (the season for military operations).

**aestimātiō**, -ōnis, [aestimā- (stem of **aestimo**) + **tio**], F., *valuation*.

**aestimō**, -āvi, -ātus, -āre, [aestimō- (**aes** + **tumus**, cf. **aeditumus**)], I. v. a., *value, estimate*. — Less exactly, *regard*: **gravius** (*consider more serious, of calamities*).

**aestivus**, -a, -um, [†**aestu-** (reduced) + **ivus**], adj., *hot*. Hence, *summer* (as adj.): **tempus**.

**aestuārius**, -a, -um, [aestu + **arius** (cf. **onerarius**)], adj., (*relating to the tide*). — Only in neuter, as noun, *creek, estuary, marsh*.

**aestus**, -tūs, [root of **aedes** + **tus**], M., *heat* (plur. in same sense). Hence, *boiling, tide*.

**aetās**, -tātis, [aevo- (stem of

**aeuum**) + **tas**], F., *age* (of old or young): **aetate confectus** (*oppressed with years*).

**aeternus**, -a, -um, [aevo- (stem of **aeuum**) + **ternus** (cf. **hester-nus**)], adj., *eternal, lasting*.

**aff-**, see **adf-**.

**Africanus**, -a, -um, [Afrō- (stem of **Afer**) + **cus**], adj., *of Africa*. — Esp., sc. **ventus**, *the S.W. wind* (blowing from Africa to Italy).

**āfuisse**, **āfūturus**, see **absum**.

**Agedi(n)eum** (Agedn-), -ī, [Celtic], N., chief town of the Senones, on the Yonne (now *Sens*).

**ager**, **agrī**, [√AG (*drive*?) + **rus**, cf. Gr. ἄγρός, *acre*], M., *land* (cultivated), *fields, country* (opposed to city), *territory* (country), *cultivated lands, fields* (as opposed to woods).

**agger**, -eris, [ad-ger (for GES, root of **gero**, as stem)], M., *earth* (for a wall), *earth of a wall, a mound of earth, a wall, a mole, a dyke* (either the regular earthwork of the Romans for an entrenched camp or line of circumvallation, or the dyke of approach, a long sloping mound leading up to the height of the walls): **cotidianus** (*daily addition to the walls*).

**agg-** (except **agger**), see **adg-**.

**agitō**, -āvi, -ātus, -āre, [agitō- (as if stem of p.p. of **ago**)], I. v. a., *drive, chase*. Hence, *vex, trouble*. — Fig., *turn over* (in mind), *propose, discuss, purpose*.

**agmen**, -minis, [√AG (in **ago**) + **men**], N., *a moving, a march*. — Concretely (of bodies in motion), *a body in motion, a column, a fleet, an army, a line* (of troops in march), *a train*. — Less exactly, *an army* (not in march). Phrases: **primum** (*the van*); **novissimum** (*the rear*);

claudere (*bring up the rear*); conferto agmine (*in close order*); agmine (*on the march*): agmen legionum (*the main body*); extremo agmine (*in the rear*).

agō, cēgi, āctus, agere, [√AG], 3. v. a., *drive* (apparently from behind, cf. **duco**, *lead*): sublicas (*drive down*); vineas, turres, etc. (*set in motion, move on, advance*); ac portare (of live stock as booty, *drive off*). — Loosely, *do* (cf. "carry on"), *act, treat, discuss, plead*. — Phrases: *conventum (hold)*; **gratias** (*render, give, express*, cf. **habere** and **referre**); **quid agit** (*what is one about?*); **quid agitur** (*what is going on?*); **de obsessione agere** (*do anything about*).

agricultūra, -ae, [agrō-cultura], F., *land tillage, farming, agriculture*: **prohibere** (*from cultivating the land*).

alacer, -cris, -cre, [?], adj., *active, eager, spirited*.

alacritās, -tātis, [alacri + tas], F., *eagerness, readiness, spirit*.

ālārius, -a, -um, [ālāri- (stem of ala + ris) + ius], adj. (*belonging to the wings*). Hence, *of the allies* (who held the wings of the army). — Masc. plur., *allies, auxiliaries*.

albus, -a, -um, [?, cf. **Alpes** and Gr. ἀλφός], adj., *white* (pale, opposed to **ater**, cf. **candidus**, *shining white*, opposed to **niger**): **plumbum album** (*tin*).

alcēs, -is, [Teutonic, cf. *elk*], F., *the elk* (a large beast of the deer kind, resembling the moose).

Alduasdubis, various reading for Dubis, I. 38, a tributary of the Saône.

Alesia, -ae, [Gallic], F., a city of the Mandubii, west of Dijon (now *Alise*).

aliās [unc. case-form of **alius**, but cf. **foras**], adv., *elsewhere*. — Of time, *at another time*: **alias... alias** (*now... now*, cf. **alius... alius**).

aliēnātus, p.p. of **alieno**.

aliēnō, -āvi, -ātus, -āre, [alienō-], 1. v. a., *make another's* (cf. **alienus**). — Also, *make strange, alienate, estrange*: **alienata mente** (*in a frenzy*).

aliēnus, -a, -um, [unc. stem akin to **alius** (prob. imitated from verb-stems of second conjugation) + **nus** (cf. **egenus**)], adj., *another's, of others, other people's*: **fines** (*others'*); **aes** (*debt*). Hence, *strange, foreign, unfavorable* (cf. **suus**), *foreign to the purpose*. — Superl., masc. plur. as noun, *perfect strangers*.

aliō [dat. of **alius**], adv., *elsewhither, elsewhere* (of end of motion).

aliquamdiū [aliquam diu, cf. **quandiu**], adv., *for some time, some time, a considerable time*.

aliquandō [unc. form, cf. **quando** and **aliquis**], *at some time*. — Emphatically, *at last* (at some time, though not before).

aliquantō, see **aliquantus**.

aliquantus, -a, -um, [ali- (reduced stem of **alius**) -quantus (cf. **aliquis**)], adj., *considerable*. — Neut., as noun, *a good deal, a considerable part*. — **aliquantō** (as abl. of measure), *by considerable, considerably*.

aliquis (-quī), -qua, -quid (-quod), [ali- (reduced stem of **alius**) -quis], pron. (more forcible than **quis**; not universal, like **quisquam**), *some, any*. — Emphatic, *some* (considerable), *any* (important). — As noun, *some one, any one, something, anything*.

aliquot [ali- (reduced stem of **alius**) -quot], pron. indecl., *several*,

*some* (more than one, but not conceived as many).

**aliter** [ali- (reduced stem of **alius**) + **ter** (cf. **acriter**)], adv., *otherwise, differently*. — Often rendered by a noun or adjective implied in the context, **aliter se habere ac** (*be different from what, etc.*); **nec aliter sentire quin** (*have no other idea but to or that*).

**alius**, -a, -ud, [unc. root (cf. *else*) + **ius** (√YA)], adj. pron., *another* (any one, not all), *other, different, else, another* (of the second of three or more). — Repeated (either in separate clauses or in same), *one . . . another, one another, one one* (thing), *another another*: **alius alia causa illata** (*alleging different reasons*); **alius ex alio** (*from different, etc., one from one, another from another*). — Esp. in a partitive use, **ex aliis** (with sup., *most of all others*, cf. "the fairest of her daughters, Eve"); **alius atque** (see **atque**).

**allātus**, see **adfero**.

**alliciō**, see **adlicio**.

**Allobroges**, -um, [Celtic], M. pl., a Celtic people (of Gaul), living between the Rhone, the Isère, the Lake of Geneva, and the Alps (in *Dauphiny and Savoy*). They were conquered in 121 B.C. by Fabius Maximus.

**alō**, alui, altus, alere, [√AL, cf. **adolesco**], 3. v. a., *cause to grow, feed, nurse, support* (supply with food), *foster, raise* (of animals): **staturam** (*increase*). — Fig., *foster, foment, feed*.

**Alpēs**, -ium, [√ALP (Celtic form of ALBH, cf. **albus**) + **is**], F. pl., *the Alps*, more or less loosely used of the whole mass of mountains between Italy (Cisalpine Gaul), Gaul, and Germany.

**alter**, -era, -erum, [√AL- (in **alius**) + **ter** (for -**terus**, comparative suffix)], pron. adj., *the other* (of two). — In plur., *the other party*. — Repeated (cf. **alius**), *one the other, one another* (of two), *one . . . the other*. — In plur., *one party . . . the other*. — Also, *the second* (of more than two), *another* (the second of three): **dies** (*the second*). — Also (esp. with negatives), *another* (beside one's self, where all are conceived as two parties, one's self and all the rest).

**alternus**, -a, -um, [**alter-** (as stem) + **nus**], adj., *alternate, reciprocal, mutual, alternating*.

**altitudō**, -inis, [altō + **tudo**], F., *height, depth* (cf. **altus**), *thickness* (of a timber).

**altus**, -a, -um, [p.p. of **alo** as adj.], *high*. — From another point of view, *deep*. — Neut., as noun, *the sea, the deep*: **in alto** (*in deep water*); **ex alto** (*from the sea*).

**alūta**, -ae, [?, cf. **alumen**], F., *leather* (of a fine sort, like morocco?).

**ambactus**, -ī, [prob. German, cf. A.S. *ambeht*], M., *a retainer, a vassal*.

**Ambarri**, -ōrum, [Celtic], plur. of adj., a tribe of Gaul, on the Saône. They seem to have been clients of the Hædui, and are called (if the reading is correct in i. 11), Hædui Ambarri.

**Ambiāni**, -ōrum, [Celtic], M. plur. of adj., a Belgian tribe, whose chief town, Samarobriua, is now called from their name, *Amiens*.

**Ambibarri** (**Ambibari**), -ōrum, [Celtic], M. plur. of adj., an Armorican tribe living in a part of Normandy.

**Ambilareti**, see **Ambivareti**.

**Ambiliāti**, -ōrum, [Celtic], M. plur. of adj., a tribe on the Somme (possibly part of the preceding).

**Ambiorix**, -igis, [Celtic], M., an able prince of the Eburones. He caused a revolt of his nation against Cæsar, which was partially (and came near being entirely) successful. He caused Cæsar uneasiness for several years, and eluded every effort to capture him.

**Ambivareti** (**Ambila**-), -ōrum, [Celtic], M. plur. of adj., a Gallic tribe, dependents of the Hædui.

**Ambivariti**, -ōrum, [Celtic], M. plur. of adj., a Belgic tribe on the west bank of the Meuse.

**Ambuareti**, see **Ambivareti**.

**ambō**, -ae, -ō (-ōrum), [akin to **amb**-], num. adj., *both* (together, cf. **uterque**, *both separately*).

**āmēns**, -entis, [**ab**-**mens**], adj., (*having the mind away*), *mad, crazy*.

**āmentia**, -ae, [**ament** + **ya**], F., *madness, frenzy*, (mad) *folly*.

**āmentum**, -i, [?, √AP (in **apis**-**cor**) or √AG (in **ago**) + **mentum**], N., a *thong* (attached to a javelin, and wound around it to give it a twisting motion in throwing, as with rifle missiles).

**ānfractus**, see **anfractus**.

**amicitia**, -ae, [**amicō** + **tia**], F., *friendship, friendly relations, alliance* (opposed to **hospitium**, wh. see), *personal friendship*.

**amicus**, -a, -um, [unc. stem from √AM (in **amo**) + **cus** (cf. **puſcius**, **posticus**)], adj., *friendly, well disposed*: **praesidium** (*devoted*). — As noun, M., a *friend, an ally*.

**āmissus**, p.p. of **amitto**.

**āmittō**, -misi, -missus, -mittere, [**ab**-**mitto**], 3. v. a., *let go (away), let slip, let pass*. Hence, *lose* (esp. of military losses).

**amor**, -ōris, [√AM (in **amo**) + **or** (for -os)], F., *love, affection*.

**amplē** [abl. of **amplus**], adv., *widely, largely*. — **amplius**, compar., *farther, more, longer*: **amplius quingenti** (*five hundred and more*); **ne quis**, etc., **amplius** (*any more*); **amplius obsidum** (see **amplus**); **numera amplissime missa** (*generous gifts*).

**amplificātus**, p.p. of **amplifico**.

**amplificō**, -āvi, -ātus, -āre, [**amplificō**-], 1. v. a., *increase, enlarge, extend, heighten*.

**amplitūdō**, -inis, [**amplō**+**tudo**], F., *size, extent, greatness*: **cornuum** (*spread*).

**amplus**, -a, -um, [?, perh. **amb** + stem akin to **plus**, **plenus**], adj. Of size and extent, lit. and fig., *large, wide, great*. — Esp., *prominent, of consequence, splendid, noble, distinguished*: **munera** (*lavish, valuable*); **dimissis amplioribus copiis** (*the greater part of*). — **amplius**, neut. comp. as noun (cf. **plus**), *more, a greater number*: **amplius obsidum**.

**an** [?], conj. introducing the second member of a double question, *or, or rather*. — Often with the first member only implied, *or*: **quid venirent, an speculandi causa** (*or was it, was it*).

**Anartēs**, -ium, [?], M. plur., a people in Dacia (*Transylvania*), on the river Theiss, at the eastern end of the Hercynian forest.

**Ancalites**, -um, [Celtic], M. plur., a nation of Britain.

**anceps**, -cipitis, [**amb**-**caput**], adj., (*having a head on both sides*), *double-headed*. — Less exactly, *two-fold, double*: **proelium** (*on both fronts*, of an army facing in two ways).

**ancora**, -ae, [Gr. ἄγκυρα], F., *anchor*: **in ancoris** (*at anchor*).

**Andēs**, -ium, [Celtic], M. plur., a tribe of Gaul north of the Loire, in modern *Anjou*.

**Andī**, -ōrum, the same as the **Andes**, wh. see.

**Andocumborius**, -ī, [Celtic], M., a chief man of the Remi.

**ānfractus** (**amf-**), -ūs, [**am- + fractus**], M., a bending round. Hence, a winding, a circuit, a deviation (from a straight line).

**angulus**, -ī, [prob. **ancō-** (stem of **ancus**, bent) + **lus**], M., (a little hook), a corner.

**angustē** [abl. of **angustus**], adv., narrowly, in narrow quarters (closely). — Fig., sparingly (cf. **ample**), in small quantity.

**angustiae**, -arum, [**angustō + ia**], F. plur., narrowness (prop. concrete, narrow); **itinerum** (a narrow pass); **propter angustias** (narrowness of the passage). — Fig., straits (difficult position, etc.), hard straits, difficulties: **angustiis premi** (to be hard pushed).

**angustus**, -a, -um, [**angor** (for **angos**) + **tus**], adj., narrow, confined: **angustiora castra** (less extensive); **montes** (confining, by which one is hemmed in). — Fig., in **angusto res est** (the position is critical).

**anima**, -ae, [**ani-** (treated as root, fr.  $\sqrt{\text{AN}}$ , blow) + **ma** (F. of **mus**), cf. **animus**], F., breath. Hence, soul. — Plur., the soul (of man, abstractly).

**animadvertō**, -vertī, -versus, -vertere, (also **animum adverto** uncontracted), [**animum adverto**], 3. v. a., turn the mind to, attend to: **in aliquem** (punish, cf. the domestic "attend to"). — Less exactly, observe, notice, learn.

**animal**, -ālis, [**anima + lis**, N. of adj.], N., (a creature endowed with life), an animal (including man), a living creature (opposed to booty).

**animus**, -ī, [**ani-** (stem as root, fr.  $\sqrt{\text{AN}}$ , blow) + **mus** (cf. Gr. **ἀνεμος**, wind)], M., breath, life, soul (vital). — Usually (the above meanings being appropriated to **anima**, wh. see), soul (as thinking, feeling), mind, feelings, feeling, intellect (but cf. **mens**), spirit: **effeminare**; **levitas animi** (disposition, nature, or together, want of constancy); **animus relinquit aliquem** (one faints); **animi mollitia** (want of energy or endurance); **animo paratus** (resolute); **animus advertere** (see **animadverto**). — Esp. (in a good sense, often in plur.), spirit, constancy, courage, resolution: **confirmare** (encourage any one); **relanguescere**; **promptus**; **paratus ad aliquid**. — Also (as opposed to **mens**, which see), the moral powers, will, desires, affections, etc., the heart, the feelings, the disposition: **bono animo esse** (be well disposed); **esse in animo alicui** (to have in mind, as a purpose); **offendere** or **avertere** (feelings); **magni animi** (of great ambition). — Also, **animus magnus** (courage, magnanimity, lofty spirit); **animi magnitudo** (lofty spirit); **permulcere** (angry spirit); **mentes animosque perturbare** (minds, as thinking, and hearts, as feeling, etc.); **animi virtus** (nobleness of soul); **animi causa** (for pleasure).

**annōtinus**, -a, -um, [some form of **annō + tinus** (cf. **diutinus**)], adj., last year's, old (of ships made the year before).

**annus**, -ī, [?], M., a year (as a

point of time, or as the course of the year, or as a period).

**annuus**, -a, -um, [annō + us], adj., *annual*: **magistratus creatur** (annually).

**ānsēr**, -eris, [for **hanser**, akin to *goose*], M., a *goose*.

**ante** [old **antid**, abl. of †**anti** (cf. **post** and **postis**)], adv., *before* (of place and time), *in front*: **antedictum** (*above, before, previously*); **antequam**, *before* (with clause); **iam ante** (*already before, already*); **paucis ante diebus** (*a few days before*). — Prep., *before* (of place or time): **ante se mittit** (*in advance of*). — In dates, **ante diem** (a. d.) (*on such a day before*). — In comp., *before* (of place, time, and succession).

**anteā** [ante eā (prob. abl. or instr., cf. eā, quā)], adv. (of time), *before, previously, once*.

**antecēdō**, -cēssi, -cēssus, -cēdere, [ante-cedo], 3. v. n. and a. (fr. force of prep.), *go forward, advance, surpass* (in size, etc.), *exceed, precede, go in advance of*.

**antecursor**, -ōris, [ante-cursor], M., a *courier*.

**anteferō**, -tuli, -lātus, -ferre, [ante-fero], irr. v. a., (*place in advance, prefer*). — Pass., *be preferred, be the first, have the superiority*.

**antemna**, -ae, [perh. borr. fr. some Gr. word fr. South Italy akin to ἀντηνῶν], F., a *yard* (for sails).

**antenna**, see **antemna**.

**antepōnō**, -posui, -positus, -pōnere, [ante-pono], 3. v. a., (*place in advance, cf. antefero*), *think of more importance*.

**antequam**, see **ante**.

**antevertō**, -verti, -versus, -vertere, [ante-vertō], 3. v. a., (*turn in front, cf. antepono*), *prefer*.

**antiquitus** [antiquō + tus], adv., *from ancient times, from early times*. — Less exactly, *long ago, in early times, anciently*.

**antiquus**, -a, -um, [anti- (cf. **ante**) + cus (cf. **porticus**)], adj., *old* (existing from early times, not so much in reference to present age as to former origin, cf. **vetus**), *ancient*.

**Antistius**, -i, [antisti- (antistes) + ius], M., a Roman gentile name. — Esp., *Gaius Antistius Reginus*, a legatus of Cæsar.

**Antōnius**, -ī, [?], M., a Roman family name. — Esp.: 1. *Marcus* (Mark Antony), the famous triumvir, a legatus of Cæsar in Gaul; also, 2, his brother, *Gaius*, a legatus of Cæsar.

**Ap**, **Appius** (wh. see).

**aperiō**, -perui, -pertus, -perire, [ab-pario (*get off*), cf. **operio**, *cover*], 4. v. a., *uncover, open*. — **apertus**, -a, -um, p.p. as adj., *open, exposed, uncovered, unobstructed, unprotected*: **latus** (*the right side, not covered by the shield*); **collis** (*without trees*); **impetus maris** (*unbroken*).

**apertē** [abl. of **apertus**], adv., *openly*.

**Apollō**, -inis, [?], M., the son of Jupiter and Latona and twin brother of Diana, god of the sun, of divination, of poetry and music, and president of the Muses. He was also god of archery, of pestilence, and, on the other hand, of healing. He is identified by Cæsar with some Celtic divinity.

**apparō**, see **adparo**.

1. **appellō**, see **adpello**.

2. **appellō**, -āvi, -ātus, -āre, [†adpellō-, cf. **compello**], 1. v. a., *call name, address, call upon, style* (de

clare one something or address in a certain character).

**appetō**, see **adpeto**.

**Appius**, -ī, [?, a Sabine word?], M., a Roman prænomen.

**applicō**, see **adplico**.

**apportō**, see **adporto**.

**approbō**, see **adprobo**.

**appropinquō**, see **adpropinquo**.

**Apr.**, abbrev. for **Aprilis** (wh. see).

**Aprilis**, -e, [prob. akin to **aperio**], adj., *of April*.

**aptus**, -a, -um, [√<sup>AP</sup> (in **apiscor**) + **tus**], adj., (*fitted to*), *suited, adapted, fit, apt*.

**apud** [akin to **ab** and Gr. ἀπὸ], prep., *at, among, with, before, on one's part, in relation to* (a person), *in one's house* (company, possession).

**aqua**, -ae, [?], F., *water, a water-course*: **aqua atque igni interdicerē** (a form of banishment among the Romans); **mensurae ex aqua**, *by the water-clock* (a contrivance like an hour-glass for telling time by the running of water).

**aquātio**, -ōnis, [**aquā-** (stem of **aquor**) + **tio**], F., *getting water* (cf. **pabulatio**).

**aquila**, -ae, [F. of **aquilus**, *dark gray*, perh. remotely akin to **aqua**], F., *an eagle*. — Esp., the standard of the Romans, consisting of an eagle on a staff.

**Aquilēja**, -ae, [**Aquila** + **ius**], F., a city of Cisalpine Gaul (*Venetia*), founded by a Roman colony in 182 B.C. as an outpost on the north-east.

**aquilifer**, -erī, [**aquila-fer** (reduced from **-ferus**, √<sup>FER</sup> + **us**)] M., *a standard-bearer* (of the eagle).

**Aquitānia**, -ae, [F. of adj. developed from **Aquitānus**], F., the part

of Gaul between the Province, the Pyrenees, the Garumna, and the ocean (see I. 1).

**Aquitānus**, -a, -um, [?], adj., *of Aquitania*. — Plur., as subst., *the people of Aquitania*. — Sing., *a man of Aquitania*.

**Arar**, -aris, [?], M., *the Saône*, a river of Gaul rising in the Vosges and flowing into the Rhone at Lyons.

**arbitēr**, -trī, [ad-†**biter** (√<sup>BI</sup>, in **bito**, + **trus**, cf. **-trum**)], M., *a witness*. — Less exactly, *a referee, an arbitrator*.

**arbitrium**, -ī, [**arbitrō** + **ium** (cf. **judicium**)], N., *judgment, will, pleasure* (what one sees fit to do).

**arbitror**, -ātus, -ārī, [**arbitrō-**], I. v. a. and n., *think, suppose* (judge).

**arbor**, -oris, [?], F., *a tree*.

**arcessō**, -sivī, -sītus, -sere, [akin to **accedo**, but the exact relation uncertain], 3. v. a., *summon, invite, send for* (persons), *call in*: **aliquem mercede** (*call in to serve for pay*).

**ardeō**, arsi, arsus, ardēre, [prob. aridō-, cf. **ardifer**], 2. v. n., *be hot, be on fire*. — Fig., *be excited, be in a blaze, burn*.

**Arduenna**, -ae, [?], F., *the Ardennes* (a very large forest region in N.E. Gaul).

**arduus**, -a, -um, [?, perh. = Gr. ὄρθος], adj., *high, steep, difficult* (of ascent).

**Arecomici**, -ōrum, [?], M. plur. See **Volcae**.

**Arēmoricus**, see **Armoricus**.

**argentum**, -ī, [akin to **arguo**, *the shining metal*], N., *silver* (the metal). Also, of things made of the metal, *silver ware, silver*.

**argilla**, -ae, [diminutive, akin to **arguo**, originally *white clay*], F.,



*clay*: **fusilis** (some vitrifying earth, such as porcelain is made of).

**āridus**, -a, -um, [†**arō-** (whence **areo**) + **du-**], adj., *dry*. — Neut. as subst., *dry land*.

**ariēs**, -ietis (-jetis), [†], M., *a ram*. — Fig., *a battering ram* (a long timber armed at the end with metal for demolishing walls). — Less exactly, *a buttress* (piles driven down in a stream to brace a bridge).

**Ariovistus**, -ī, [†], M., a chief of the Germans, called in by the Gauls in their domestic quarrels, who conquered and ruled them until he was himself crushed by the Romans.

**Aristius**, -ī, [†, **Arista** + **ius**?], M., a Roman gentile name. — Esp., **Marcus**, a tribune of the soldiers in Cæsar's army.

**arma**, -ōrum, [√**AR** (*fit*, cf. **armus**, *the shoulder joint*) + **mus**], N. plur., *arms, equipment*: **armis jus exsequi** (*by force of arms*); **in armis esse** (*to be under arms, to be ready for service, to be in service*); **paratī in armis** (*armed for war*); **in armis** (*in battle*); **armis congressi** (*in battle*), and the like.

**armāmenta**, -ōrum, [**armā-** (stem of **armo**) + **mentum**], N. plur., *implements*. — Esp., *rigging, tackle*.

**armātūra**, -ae, [**armā-** (stem of **armo**) + **tura**], F., *equipment*: **levis armaturæ Numidæ** (*light armed, without the heavy defensive armor of the legionary*).

**armātus**, -a, -um, p.p. of **armo**.

**armō**, -āvī, -ātus, -āre, [**armō-** (stem of **arma**)], I. v. a., *equip, arm*. — Pass., in middle sense, *arm* (one's self). — **armātus**, -a, -um, p.p. as adj., *armed, in arms, equipped*.

**Armorican** (**Arēm-**), -a, -um, [Celtic *are, near*, and *mor, the sea*],

adj., only F. plur., *Armorican* (of the states of Gaul near the ocean, in Normandy and Brittany; see V. 53).

**Arpinējus**, -ī, [**Arpinō-** (stem of **Arpinum**) + **eius**], M., a Roman gentile name. — Esp., **Gaius**, a Roman knight in Cæsar's army, possibly of Gallic origin, of a family enfranchised by Marius, who came from Arpinum.

**arripiō**, see **adripiō**.

**arroganter**, see **adroganter**.

**arrogantia**, see **adrogantia**.

**ars**, **artis**, [√**AR** + **tis** (reduced)], F., *skill, art*. — Plur., *the arts, the useful arts*.

**artē** [abl. of **artus**], adv., *closely, tightly*.

**articulus**, -ī, [**artu-** (stem of **artus**) + **culus**], M., *a little joint*. — Less exactly, *a joint*.

**artificium**, -ī, [**artific-** (stem of **artifex**) + **ium**], N., *a skilful contrivance, an artifice, a trick*. Also, *a trade* (opposed to **ars**, *a higher art*).

**artus**, -a, -um, [p.p. of **arceo**, but poss. √**AR** (cf. **ars**) + **tus**], as adj., *tightly bound, close*: **silva** (*thick*).

**Arvernus**, -a, -um, [Celtic], adj., *of the Arverni* (a powerful Gallic tribe west of the Cevennes in modern Auvergne). — Masc. plur., *the people*.

**arx**, **arcis**, [√**arc** (in **arceo**, **arca**) + **is** (reduced)], F., *a stronghold, a fortress*.

**ascendō**, see **adscendo**.

**ascēsus**, see **adscensus**.

**aspectus**, see **adspectus**.

**asper**, -era, -erum, [†], adj. *rough, harsh*. — Fig., *violent*.

**assiduus**, see **adsiduus**.

**assistō**, see **adsisto**.

**assuēfaciō**, see **adsuefacio**.

**assuñfactus**, see **adsuefactus**.

**assuñscō**, see **adsuesco**.

**assuētus**, see **adsuetus**.

**at** [prob. form of **ad**], conj., *but, at least*.

**atque** (**ac-**), [**ad-que**], conj., and (generally introducing some more important idea), *and even, and especially*. — Also, *as, than*: **par atque** (*the same as*); **simul atque** (*as soon as*); **similis atque** (*just like*); **aliter ac** (*otherwise than, different from what, etc.*); **aliud atque** (*different from, etc.*).

**Atrebas**, -atis, [Celtic], adj., *Atrebatian, of the Atrebates* (a people of Belgic Gaul), rarely sing. of one. — Plur., the nation itself. — Also, **Atrebatis**, ablative plur., as if from **Atrebatī**, -orum (cf. the declension of **poema**).

**Atrius**, -ī, [atrō- (stem of **ater**) + **ius**], M., a Roman gentile name. — Esp., *Quintus*, a soldier in Cæsar's army.

**attexō**, -texuī, -textus, -texere, [**ad-texo**], 3. v. a., *weave on, make on* (by weaving).

**attingō** (**adt-**), -tigi, -tactus, -tingere, [**ad-tango**], 3. v. a., *touch upon, touch, reach, join* (of a nation's boundaries).

**attribuō** (**adt-**), -buī, -būtus, [**ad-tribuo**], 3. v. a., *assign*.

**attuli**, see **adfero**.

**auctor**, -ōris, [√AUG (in **augeo**) + **tor**], M., *a voucher* (for any act or statement), *an authority, an adviser*: **defectionis** (*leader*); **auctor esse** (*approve, advise*); **eis auctoribus** (*with their approval*); **auctore hoste** (*on the authority of the enemy*).

**auctōritās**, -tātis, [**auctor-** (as if i-stem) + **tas**], F., *influence, prestige,*

*authority* (not political nor military, cf. **imperium** and **potestas**).

**auctus**, -a, -um, p.p. of **augeo**.

**auctumnus**, see **autumnus**.

**audācia**, -ae, [**audac** + **ia**], F., *daring, boldness, effrontery*.

**audācter** [**audac** + **ter**], adv., *with daring, boldly, fearlessly* (but of an enemy): **audacissime** (*with the greatest daring*).

**audāx**, -ācis, [**audā-** (as if stem of **audeo**) + **cus** (reduced)], adj., *daring*.

**audēō**, ausus, audēre, [prob. **avido-** (stem of **avidus**)], 2. v. a. and n., *dare, venture, risk, dare to try* (or *do*). — **ausus**, -a, -um, p.p. in pres. sense, *daring*.

**audiō**, -divī, -ditus, -dire, [prob. akin to **auris**], 4. v. a., *hear, hear of*. — **audiēns**, -ntis, p. as adj., *obedient* (with **dicto**).

**auditiō**, -ōnis, [**audī-** (stem of **audio**) + **tiō**], F., *a hearing, hearsay, report*.

**augeō**, auxī, auctus, augēre, [√AUG (causative or fr. unc. noun-stem)], 2. v. a., *increase, magnify, enhance, add to* (something). — Pass., *increase*.

**Aulercus**, -a, -um, [Celtic], adj., *of the Aulerici* (a wide-spread people of several tribes in the interior of Gaul). — Plur., the people themselves.

**Aulus**, -ī, [?], M., a Roman prænomen.

**aurīga**, -ae, [poss. akin to **auris** and **ago**, cf. **aurea**, **headstall**], C., *a charioteer, a driver*.

**auris**, -is, [akin to **ear**, stem †**auri-** (cf. **audio**)], F., *an ear*.

**Aurunculējus**, -ī, [**Aurunculō-** (dim. of **Auruncus**, name of an Italian tribe) + **eius**], M., a Roman

gentile name. — Esp., *Lucius Aurunculeius Cotta*, a legatus of Cæsar.

**Auscī**, -ōrum, [Celtic], M. plur. of adj., a tribe of Aquitania.

**ausus**, -a, -um, p.p. of *audeo*.

**aut** [?, but cf. *autem*], conj., or (regularly exclusive, cf. *vel*). — Repeated, *either . . . or*.

**autem** [?, akin to *aut*], conj., *but* (the weakest degree of opposition, cf. *sed*), *on the other hand, then again, now* (explanatory), *whereas* (in slight opposition to something preceding).

**autumnus** (*auct-*), -ī, [for †*auctomīnus*, †*auctō-* (cf. *augeo*) + *minus* (cf. *Vertumnus*)], M., *autumn* (the season of increase).

**auxiliāris**, -e, [*auxiliō-* (as if *auxiliā*) + *ris* (cf. *alaris*)], adj., *auxiliary*. — Plur. as noun, *auxiliaries, auxiliary troops* (not Roman legionaries).

**auxilior**, -ātus, -ārī, [†*auxiliō-*], I. v. dep., *give assistance*.

**auxilium**, -ī, [†*auxili-* (akin to *augeo*, cf. *fusilis*) + *ium*], N., *assistance, aid, remedy, relief*: **extremum** (*the last resource*); **ferre** (*to assist, to aid*); **auxilio** (*as a reinforcement*); **quos auxili causa habebat** (*as auxiliaries, etc.*). — Plur., *auxiliaries* (as opposed to the regular heavy-armed infantry); *reinforcements*: **auxilia tardare** (*hinder from rendering assistance*).

**Avaricēnsis**, -e, [†*Avaricō* + *ensis*], adj., *of Avaricum*. — Plur., *the people of Avaricum*.

**Avaricum**, -ī, [Celtic], N., a town of the Bituriges (now *Bourges*).

**avāritia**, -ae, [†*avarō* + *tia*], F., *covetousness, greed, avarice*.

**āvehō**, -vexī, -vectus, -vehere, [†*abveho*], 3. v. a., *carry off, carry away*.

**āversus**, -a, -um, p.p. of “*verto*.  
**āvertō**, -vertī, -versus, -vertere,

[†*ab-verto*], 3. v. a., *turn aside, turn off, push aside*. — Fig., *alienate, estrange*. — **āversus**, -a, -um, p.p. as adj., *turned away*. Hence, *flying*, or, with a change of point of view in translation, *in the rear* (of that to which the word is applied): **ne aversi ab hoste circumventur** (*by the enemy getting in their rear, etc.*).

**avis**, -is, [unc. root + *is*], F., a *bird*.

**avus**, -ī, [?], M., a *grandfather*.

**Axona**, -ae, [Celtic], F., a river of Gaul (now *Aisne*), a tributary of the Isara (*Oise*).

## B.

**Bacēnis**, -is, [Celtic], F., with *silva*, a forest of Germany between the Cherusci and the Suebi.

**Baculus**, -ī, [*baculus* = *baeu- lum, staff*], M., agnomen of Publius Sextius Baculus, a centurion in Cæsar's army.

**Baleāris**, -e, [?], adj., *Balearic* (belonging to the Balears insulae in the Mediterranean, now *Majorca* and *Minorca*, famous for their slingers). — Plur., the islands themselves.

**balteus**, -ī, [?], M., a *belt* (for the sword, passing over the shoulder, but sometimes also encircling the waist).

**Balventius**, -ī, [?], M., a Roman gentile name, only with *Titus*, a centurion in Cæsar's army.

**barbarus**, -a, -um, [prob. fr. imitation of unintelligible speech, cf. **balbus**], adj., *foreign* (not Greek or Latin), *uncivilized, savage, barbarian, of the barbarians*. — Plur.,

the *basavrians* or *savages* (used of the Gauls).

**Basilus**, -ī, [?], M., agnomen of *Lucius Minucius Basilus*, an officer in Cæsar's army.

**Batavī**, -ōrum, [Celtic], M. plur., *the Batavians* (a nation occupying the region about the mouths of the Rhine).

**Belgae**, -ārum, [?], M. plur., *the Belgians* (a nation occupying the northern part of Gaul).—Perhaps also a small tribe of the nation with this special name.

**Belgium**, -i, [Belga + ium], N., the country of the Belgians.

**bellicōsus**, -a, -um, [bellicō + osus], adj., *warlike*.

**bellicus**, -a, -um, [bellō + cus], adj., *of war, in war*.

**bellō**, -āvī, -ātus, -āre, [bellō-], I. V. N., *fight, make war*: **studium bellandī** (*a passion for war*).

**Bellocassī**, -ōrum, see **Velocasses**.

**Bellovacī**, -ōrum, [?], M. plur., a Gallic tribe between the Seine, Somme, and Oise, about modern Beauvais.

**bellum**, -i, [old **duellum**, from **duo**, *a strife between two*], N., *war, a war*: **bello persequi**, etc. (*in arms*); **bellum inferre** (*make war, offensive*); **parare bellum** (*make warlike preparations*).

**bene** [abl. of **bonus**], adv., *well*: **bene gerere negotium** (*be successful in, etc.*).

**beneficium**, -ī, [beneficō- (reduced) + ium (but cf. **officium**)], N., *well-doing, a service, a favor*, often rendered by Eng. plur., *services, favors shown, services rendered*: **sortium beneficio** (*thanks*

*to the lot*); **beneficio suo adductus** (*by gratitude for his favors*).

**benevolentia**, -ac, [benevolent + ia], F., *good-will, kindness*.

**Bibraete**, -is, [Celtic], N., the chief town of the Hædui (now *Auntun*, from its later name Augustodunum).

**Bibrax**, -ctis, [cf. last word], F., a town of the Remi not satisfactorily identified.

**Bibroci**, -ōrum, [Celtic], M. plur., a tribe of south-east Britain.

**biduum**, -ī, [†dvi-duum (akin to **dies**)], N., *two days' time, two days*.

**biennium**, -ī, [bienni- (bi-annō) + ium], N., *two years' time, the space of two years, two years*.

**Bigerriones**, -um, [Celtic], M. plur., a tribe of the Pyrenees (*Bigorre*).

**bīni**, -ae, -a, [†dvi + nus], adj. plur., *two each, two sets of, two* (of things in pairs or sets).

**bipartitō** [abl. of **bipartitus**], adv., *in two divisions*: **bipartito collocatis insidiis** (*in two places*).

**bipedālis**, -e, [biped + alis], adj., *of two feet (measure), two feet* (long, wide, etc.).

**bis** [for **dvīs**, unc. case-form of **duo** (cf. **cis**, **uls**)], adv., *twice*.

**Bituriges**, -um, [Celtic], M. plur., a tribe of Celtic Gaul, in two branches, **Vibisci** (around Bordeaux) and **Cubi** (around Bourges).

**Bođuōgnātus**, -ī, [Celtic], M., a leader of the Nervii.

**Bōja**, F. sing. of **Bōji**, *Boian*.

**Bōji**, -ōrum, [Celtic], M. plur., a Celtic nation, of which a part occupied lands in Cisalpine Gaul, a part settled in Pannonia, and a part were with the Helvetii in their emigration.

**bonitās**, -tātis, [†bonō + tas], F., *goodness*: **agrorum** (*fertility*).

**bonus**, -a, -um, [?], adj., *good*: **bono animo esse** (*to be well disposed*); **optimum est** (*it is best*); **optimum iudicium facere** (*express so high an opinion*). — Neut. as subst., *good, advantage*. — Plur., *goods, property, estate*.

**bōs**, **bovis**, [akin to *cow*], C., *a bull, a cow, an ox*. — Plur., *cattle*.

**bracchium** (brāch-), -ī, [?], N., *an arm*.

**Brannovices**, -um, [Celtic], M. plur., a division of the Auleri living near the Hædui.

**Brannovii**, -ōrum, [Celtic], M. plur., a Celtic tribe, dependents of the Hædui.

**Bratuspantium**, -ī, [Celtic], N., a fortified town of the Bellovaci, not certainly identified.

**brevis**, -e, [for †bregus, √BRAGH + us], adj., *short* (of space or time): **brevis** (*in a short space*).

**brevitās**, -tātis, [†brevis + tas], F., *shortness, short stature*: **brevitas temporis** (*want of time*).

**breviter** [†brevis + ter], adv., *briefly*.

**Britanni**, -ōrum, [Celtic], M. plur., *the Britons* (including all tribes of Britain).

**Britannia**, -ae, [†Britannō + ia (F. of ius)], F., *Britain*.

**Britannicus**, -a, -um, [†Britannō + cus], adj., *of Britain, Briton*: **bellum** (with Britain).

**brūma**, -ae, [†brevis + ma (superl.), sc. dies], F., *the winter solstice*.

**Brūtus**, -ī, [brūtus, *heavy*], a family name at Rome. — Esp., *Decimus Junius Brutus Albinus*, a legatus of Cæsar. He distinguished him-

self in command of Cæsar's fleet off the coast of Gaul, and afterwards in the civil war on the side of Cæsar. But he joined the conspiracy against Cæsar with Marcus Brutus, and was one of Cæsar's assassins. He was afterwards killed in Gaul by order of Antony.

## C.

C, 100.

C., see **Gajus**.

**Cabillōnum**, -ī, [Celtic], N., a town of the Hædui on the Saone (*Chalons-sur-Saône*).

**Cabūrus**, -ī, [Celtic], M., the personal name of *Caius Valerius Caburus*, a Gaul, made a Roman citizen by C. Valerius Flaccus, and father of C. Valerius Proculus and C. Valerius Donnotaurus.

**cacūmen**, -inis, [?], N., *the top* (of trees, mountains, etc.).

**cadāver**, -eris, [akin to **cado**], N., *a corpse, a body* (dead).

**cadō**, **cecidi**, **cāsūrus**, **cadere**, [√CAD], 3. v. n., *fall, be killed*.

**Cadurcus**, -a, -um, [Celtic], adj., *of the Cadurci* (a tribe of Aquitania). — Plur., *the people themselves*.

**caedēs**, -is, [†caed (as root of **caedo**) + is], F., *a murder, a massacre, slaughter*.

**caedō**, **cecidi**, **caesus**, **caedere**, [prob. causative of **cado**, cf. *fall, fell*], 3. v. a., *strike, strike down, fell, cut down, slay*.

**caelestis**, -e, [†caelit- (stem of **caeles**) + tis (cf. **agrestis** and **modestus**)], adj., *heavenly*. — Plur., *the gods*.

**caelum**, -ī, [?], N., *the sky, the heavens, heaven* (as the abode of the gods).

**caerimōnia**, -ae, [?], F., a *rite*, a *ceremony*.

**Caeroesi**, -ōrum, [?], M. plur., a tribe of Belgic Gaul.

**caeruleus**, -a, -um, [perh. akin to **caesius**], adj., *dark blue*.

**Caesar**, -aris, [?], M., a family name in the gens Iulia. — Esp.: 1. *C. Julius Caesar*, the conqueror of Gaul and the author of the *Commentaries*. — 2. *L. Julius Caesar*, a kinsman of the former, acting as his legatus in Gaul.

**caespes**, see **cespes**.

**caesus**, -a, -um, p.p. of **caedo**.

**Cāius**, see **Gājus**.

**Cal.**, see **Calendae**.

**calamitās**, -tātis, [?], F., *disaster* (orig. to crops?), *defeat*, *misfortune* (also euphemistically for death): *ejus* (*any accident to him*).

**Calendae**, -ārum, [akin to **calo**, *call*, the day when the phases of the moon were announced to the people by the priests], F. plur., *the Kalends* (the first day of the Roman month).

**Caletī**, -ōrum, and **Calētes**, -um, [Celtic], M. plur., a tribe in Normandy, on the Seine.

**callidus**, -a, -um, [†**callō**- (cf. **callum**) + **dus**], adj., (*tough?*), *shrewd*, *cunning*, *skilful*.

**cālō**, -ōnis, [?], M., a *servant* (of a soldier), a *camp follower*.

**campester**, -tris, -trē, [†**campō** + **ster**, as if †**campet** + **tris** (cf. **equestris**)], adj., *of the plain*: *loca* (*level plains*).

**campus**, -ī, [?], M., a *plain*.

**Camulogēnus**, -ī, [Celtic], M., a chief of the Auleri.

**Caninius**, -ī, [?], M., a Roman gentile name. — Esp., *C. Caninius Rebilus*, a legatus of **Cæsar**.

**canō**, *cecini*, *cantus*, *canere*,

[√**CAN**], 3. v. a. and n., *sing*, *sound* (with voice or instrument).

**Cantaber**, -bra, -brum, [Celtic], adj., *of the Cantabri* (a warlike people in the north of Spain, allied with the Gauls of Aquitania). — Plur., the people.

**Cantium**, -ī, [Celtic], N., *Kent* (the south-east corner of Great Britain).

**caper**, -prī, [?], M., a *goat*.

**capillus**, -ī, [adj. form akin to **caput**], M., *the hair* (collective).

**capio**, cēpī, *captus*, *capere*, [√**CAP**], 3. v. a., *take*, *capture*, *take possession of*, *get*, *acquire*, *seize*: *stipendium*; *nomen*; *arma* (*take up*); *montem*. — Less exactly, *choose*, *select*: *locum*. — So also (esp. of vessels), *reach*: *portus* (*arrive at*). — Fig., *take in* (*deceive*), *captivate*, *beguile*, *experience*: *dolorem*; *conjecturam* (*make*); *quietem* (*take*, *enjoy*); *fugam* (*take to flight*).

**caprea**, -ae, [†**caprō**- (reduced) + **ea** (F. of **-eus**)], F., a *roe* (a small animal of the deer kind, with branching horns and a dappled skin).

**captivus**, -a, -um, [as if †**capti**- (imaginary stem of **capto**) + **vus**], adj., *captive*. — Masc. as noun, a *captive*, a *prisoner*.

**captus**, -a, -um, p.p. of **capio**.

**captus**, -ūs, [†**CAP** + **tus**], M., a *seizing*. Hence, *what one can grasp*. — Fig., *capacity*, *character*, *nature*.

**caput**, -itis, [?, akin to **head**], N., *the head*: *capite demisso*; *capite solo ex aqua exstare* (*have only the head above water*). — Less exactly, *person* (cf. "head of cattle"), *mouth* (of a river). — Fig., *life*: *poenam capitis* (*of death*); *capitis periculo* (*of life*).

**careō**, -uī, -itūrus, -ēre, [?], 2. v. *be without*, *go without*.

**carīna**, -ae, [?], F., *keel, bottom* (of a ship).

**Carnūtes**, -um, [Celtic], M. plur., a Gallic people between the Loire and the Seine, about *Orléans*.

**carō**, *carnis*, [akin to **crudus** and *razū*], F., *flesh, meat*.

**carpō**, -psī, -ptus, -perc, [akin to *harvest*], 3. v. a., *pluck*. — Fig., *find fault with* (cf. "pick at").

**carrum**, -ī, [Celtic], N., *a cart* (of the Gauls).

**carrus**, -ī, M., another form for **carrum**.

**cārus**, -a, -um, [?], adj., *dear, precious, valuable*.

**Carvilius**, -ī, [?], M., a Roman gentile name. — Also, a king of part of Kent.

**casa**, -ae, [?], F., *a cottage, a hut*.

**cāseus**, -ī, [?], M., *cheese*.

**Cassī**, -ōrum, [Celtic, cf. **Velo-** **casses** and **Cassivellaunus**], M. plur., a British tribe.

**Cassianus**, -a, -um, [†**Cassiō** (reduced) + **ānus** (cf. **Romanus**)], adj., *of Cassius*: *bellum* (the war in B.C. 107, in which L. Cassius Longinus was defeated by the Tigurini, near Lake Geneva, and killed).

**cassis**, -idis, [?], F., *a helmet* (of metal, for horsemen, cf. **galea**).

**Cassius**, -ī, [?], M., a Roman gentile name. — Esp., *L. Cassius Longinus*, consul B.C. 107 (see **Cassianus**).

**Cassivellaunus**, -ī, [Celtic], M., a British chief ruling north of the Thames, who took command of the general resistance of his countrymen to Cæsar, but was finally reduced to submission.

**castellum**, -ī, [†**castrō** + **lum** (N. of **-lus**)], N., *a fortress, a fort, an outwork, a redoubt*.

**Casticus**, -ī, [Celtic], M., a chief of the Sequani.

**castigō**, -āvī, -ātus, -ārc, [†**castigō** (stem of lost adj. †**castigus**, **castō-igus**, cf. **prodigus**)], 1. v. a., *make pure, reform*. Hence, *chide, reprove*.

**castrum**, -ī, [√**SKAD** (*cover*) + **trum**], N., *a fortress*. — Plur., *a camp* (fortified, as was the manner of the Romans): *in castris* (*in camp*, also *in service*); *castra ponere* (*pitch a camp*); *castra movere* (*break camp, move*); *quintis castris* (*after five days' journey*, as the Romans encamped every night).

**cāsus**, -ūs, [√**CAD** + **tus**], M., (*what befalls*), *an accident, a chance* (good or bad), *a mischance*: *hoc ipso tempore et casu* (*emergency*); *casu* (*by accident, by chance*); *casu devenit* (*chanced to, etc.*); *quarum rerum casus* (*the occurrence, the happening*); *eundem casum ferre* (*take the chances*); *in eiusmodi casu* (*a case*); *ad extremum casum* (*to the most critical position*); *ad omnes casus* (*against all accidents*); *in eum casum deduci* (*that pass*).

**Catamantaloedēs**, -is, [Celtic], M., a chief of the Sequani.

**catēna**, -ae, [?], F., *a chain* (for prisoners), *a cable*: *in catenas coniecit* (*into prison*); *in catenis tenere*.

**Caturiges**, -um, [Celtic], M. plur., a people in Roman Gaul (Provincia).

**Catuvolcus**, -ī, [Celtic], M., a chief of the Eburones.

**Caurus**, see **Cōrus**.

**causa**, -ae, [?], F., *a cause, a reason, an excuse, grounds, a motive* (for an act), *a right* (to anything): *satis causae* (*sufficient reason*). —

Abl. after a genitive, *for the sake of, for the purpose of, for, on behalf of*: **libertatis causa**; **potentiae causa** (*to gain*); **praedandi causa** (*to, etc.*); **insidiarum causa** (*for an ambushcade*); **animi causa** (*for amusement*).—Also, *a cause* (in law), *a case*: **causa cognita** (*after trial*); **causa indicta** (*unheard*); **causam dicere** (*plead one's cause, stand a trial, be tried*); **causae dictio** (*a trial*). Hence, also, *a situation, a case*: **Germanorum unam esse causam** (*the case . . . the same*); **in eadem causa** (*in the same situation, also, on the same side*).

**cautē** [abl. of **cautus**], adv., *with caution*.

**cautēs**, -is, [akin to **cos**, *whetstone*], F., *a rock* (sharp or jagged), *a reef*.

**cautus**, p.p. of **caveo**.

**Cavarillus**, -ī, [Celtic], M., a prince of the Hædūi.

**Cavarinus**, -ī, [Celtic], M., one of the Senones, made their king by Cæsar.

**caveō**, cāvī, **cautus**, cavēre, [perh. √SKV?], 2. v. n. and a., *be on one's guard, guard against* (something), *take security* (intense).

**cēdō**, cēssī, cēssūrus, cēdere, [?], 3. v. n., *make way* (giving place).—Esp., *give way, retreat, retire*: **cedentes** (*the flying*); **cedere loco** (*abandon a position, a military term*).—Fig., *yield*: **fortunae**.

**celer**, -eris, -ere, [√CEL (in **cello**) + **ris**], adj., *swift, quick, speedy, fast*: **motus** (*sudden*).

**celeritās**, -tātis, [†**celeri** + **tas**], F., *swiftness, activity, speed, promptness*: **ad celeritatem onerandi** (*to secure quick loading*); **itineris** (*quick marching*).

**celeriter** [**celeri** + **ter**], adv., *quickly, speedily, very soon, soon*.

**cēlō**, -āvī, -ātus, -āre, [?, akin to **clam** and **caligo**], 1. v. a., *conceal, hide*: **arma**.—Pass., *pass unnoticed*.

**Celtae**, -ārum, [Celtic], M. plur., a great race in Gaul and Britain.—More particularly, *the Celts* (in a narrower sense, occupying the interior of Gaul).

**Celtillus**, -ī, [Celtic], M., one of the Arverni, father of Vercingetorix.

**Cēnabēnses**, -ium, [Cenabō + **ensis**], M. plur., the people of Cenabum.

**Cēnabum** (**Gen-**), -ī, [Celtic], N., the chief city of the Carnutes, now *Orléans* (from its later name, **urbs Aurelianensis**).

**Cenimāgnī**, -ōrum, [Celtic], M. plur., a British tribe.

**Cenomānī**, -ōrum, [Celtic], M. plur., a division of the Aulerci.

**cēnsēō**, cēnsuī, cēnsus, cēnsēre, [?], 2. v. a., (perh. *finē*), *reckon, estimate*.—Less exactly, *give one's opinion, advise, decree* (of the Senate), *determine*.

**cēnsus**, -ūs, [akin to **cēnsēō**], M., *a numbering, a census*.

**Centrōnes**, see **Ceutrones**.

**centum** (C), [akin to **hund-red**], indecl., *a hundred*.

**centuriō**, -ōnis, [†**centuria** + **o**], M., *a centurion*. A subaltern officer from the ranks, commanding a *century*, originally a hundred men. There were two in a maniple, and sixty in a legion, ranking according to the numbers of the cohorts from 1 to 10, the six of the first cohort being the **centuriones primorum ordinum**, and the one of the first century in that cohort being **primus pilus**.

**cernō**, crēvī, crētus, **cernere**,



[√CER], 3. v. a., *separate*. Hence, *distinguish, see, behold, descry*. — Also, *determine*.

**certāmen**, -inis, [†certā- (in **certo**) + **men**], N., *a struggle, a contest, rivalry*.

**certē** [abl. of **certus**], adv., *certainly, surely, at least* (surely what is mentioned, if nothing more).

**certus**, -a, -um, p.p. of **cerno** as adj., *determined, fixed, certain* (of the thing as well as the person), *sure, established*: **certiorem facere** (*inform, order*); **certissimae res** (*absolutely certain facts*); **dies certa** (*an appointed day*); **certa subsidia** (*regular, as organized beforehand*); **certum in locum** (*particular*).

**cervus**, -ī, [root of **cornu** + **vus**], M., *a stag*.

**cēspes** (**caesp-**), -itis, [?], M., *a sod* (used in fortification).

(**cēterus**), -ra, -rum, [√CE (in **ecce, hic**) + **terus** (cf. **alter**)], adj., *the rest of* (cf. **alius**, *other*, not including all). — Plur., *the rest, the remaining, the others*: **frumento ceterisque rebus** (*everything else necessary, where aliis would mean some other things*).

**Centrōnes** (**Cent-**), -um, [Celtic], M. plur.: 1. A tribe in the Graian Alps (in modern Savoy). — 2. A Belgic tribe.

**Cevenna**, -ae, [Celtic], F., *the Cévennes* (a woody mountain region on the west side of the lower Rhone valley).

**Cheruseī**, -ōrum, [?], M. plur., a tribe of the Germans between the Weser and the Elbe.

**cibārius**, -a, -um, [cibō- (reduced) + **arius**], adj., *pertaining to food*. — Neut. plur. as subst., *provisions*: **molita** (*ground corn*).

**cibus**, -ī, [?], M., *food*.

**Cicerō**, -ōnis, [cicer + o, orig. a nickname, possibly from excrescences on the nose], M., a name of a Roman family from Arpinum. — Esp.: 1. **Marcus Tullius**, the great orator. — 2. **Quintus (Tullius)**, his brother, in Caesar's service in Gaul as legatus.

**Cimberius**, -ī, [akin to **Cimbri**], M., a prince of the Suevi.

**Cimbri**, -ōrum, [?], M. plur., a German tribe living in Jutland, who overran Gaul and made a successful inroad into the Roman dominions in the second century B.C. They were conquered at Aquæ Sextiæ and Vercelli by Marius and Catulus, B.C. 103 and 102.

**Cingetorix**, -igis, [Celtic], M.: 1. A leader of the Treviri, brother-in-law of his rival, Indutiomarus. — 2. A British prince in Kent.

**ciugō**, cinxī, cinctus, cingere, [?], 3. v. a., *surround, encircle*: **flumen oppidum** (*run around*). — Less exactly, *man* (occupy in a circuit, of walls).

**cippus**, -ī, [?], M., *a stake, a pillar, a post*. — Apparently jocosely used of a peculiar form of palisades, *boundary-posts* (?).

**circā** [case-form (instr.?) of **circus** (cf. **circum**)], adv. and prep., *about, around*.

**circinus**, -ī, [circō- (cf. **circum**) + **nus**], M., *a pair of compasses, a compass*.

**circiter** [circō + **ter** (cf. **aliter**)], adv. and prep., *about*. — Fig. (of time, number, and quantity), *about* (in the neighborhood of), *near, not far from*.

**circueō**, see **circumeo**.

**circuitus**, -a, -um, p.p. of **circumeo**.

**circuitus**, -tūs, [circum-itus], *M.*, a circuit (a going round), a circuitous route, a circumference: in circuitu (all around).

**circum** [acc. of circō- ( $\sqrt{\text{KAR}}$  + *cus*, cf. *curvus*)], adv. and prep., about, around.

**circumcidō**, -cidī, -cīsus, -cīdere, [circum-caedo], 3. v. a., cut around, cut (the idea of around being implied in the context). — **circumcīsus**, -a, -um, p.p. — Fig., isolated: collis.

**circumclūdō**, -clūsī, -clūsus, -clūdere, [circum-claudo], 3. v. a., enclose around, encircle, place a band around.

**circumdatu**s, -a, -um, p.p. of **circumdo**.

**circumdō**, -dedī, -datus, -dare, [circum-2. do], 1. v. a., put around: murus circumdatus (encircling, thrown around). — By a confusion of ideas, surround, encircle: *aciem rhedis*.

**circumdūcō**, -duxī, -ductus, -dūcere, [circum-duco], 3. v. a., lead around. — Less exactly, of a line, draw around.

**circumductu**s, -a, -um, p.p. of **circumduco**.

**circu(m)eō**, -iī, -itus, -īre, [circum-eo], irr. v. n., go around. — Becoming active, visit, make a tour of: *hiberna*.

**circumfundō**, -fūdī, -fūsus, -fundere, [circum-fundo], 3. v. a., pour around. — Pass. (as reflexive), pour in, rush around, rush in on all sides. — Also (cf. **circumdo**), surround: *multitudine praesidia* (surround with a swarming multitude).

**circumiciō**, -jēcī, -jectus, -icere, [circum-jacio], 3. v. a., throw around. — Esp. in a military sense, hurl

around, throw around: *circumjecta multitudine* (assailing on all sides).

**circumjectu**s, -a, -um, p.p. of **circumicio**.

**circummittō**, -misi, -missus, -mittere, [circum-mitto], 3. v. a., lead around.

**circummūniō**, -ivī, -itus, -īre, [circum-munio], 4. v. a., fortify around, throw fortifications around, fortify, protect (by a fortification).

**circummūnitu**s, -a, -um, p.p. of **circummunio**.

**circumplector**, -plexus, -plecti, [circum-plector (cf. *amplector*)], 3. v. dep., embrace.

**circumsistō**, -stetī, no p.p., -sistere, [circum-sisto], 3. v. a., stand around, flock around, rally around, surround, hem in.

**circumspiciō**, -spēxī, -spectus, -spicere, [circum-specio], 3. v. a., look about for. — Fig., think over, consider, cast about for: *animo consilia* (by way of investigating or divining).

**circumstō**, -stetī, no p.p., -stāre, [circum-sto], 1. v. a., surround.

**circumvallātus**, -a, -um, p.p. of **circumvallo**.

**circumvallō**, -āvī, -ātus, -āre, [circum-vallo], 1. v. a., surround with walls, invest.

**circumvectu**s, p.p. of **circumveho**.

**circumvehō**, -vēxī, -vectus, -vehere, [circum-veho], 3. v. a., carry around. — Esp. pass. as dep., ride around.

**circumveniō**, -vōnī, -ventus, -venire, [circum-venio], 4. v. a., surround. — Fig. (cf. "get around"), impose upon, defraud, betray, circumvent.

**circumventus**, -a, -um, p.p. of **circumvenio**.

**cis** [case-form (gen.?, cf. **uls**, **obs**, etc.) of **ce** (cf. **ec-ce**, **cetera**)], adv. and prep., *this side, this side of*.

**Cisalpinus**, -a, -um, [**cis** **Alpes** (as if **cisalpi-**) + **nus**], adj., *being this side the Alps, Cisalpine*: **Gallia** (that part of Gaul on the Italian side of the Alps).

**Cisrhēnānus**, -a, -um, [**cis** **Rhenum** (as if **cisrhenō-**) + **nus**], adj., *being this side the Rhine, this side the Rhine* (as adj. phrase).—Plur. as subst., *the people this side the Rhine* (i.e. towards Gaul).

**Cita**, -ae, [perh.  $\sqrt{\text{CI}}$  (in **cieo**) + **ta** (cf. **nauta**)], M., a Roman family name.—Only, **C. Fufius**, a Roman knight doing business in Cenabum.

**citātus**, -a, -um, p.p. of **cito**.

**citer**, -ra, -rum, [ $\sqrt{\text{CI}}$  (cf. **cis**) + **terus** (reduced, cf. **alter**)], adj., *on this side* (rare and antiquated).—Usually **citerior** (compar.), *nearer, hither* (as adj.): **provincia** (Gaul on the Italian side of the Alps as opposed to Farther Gaul, cf. **Cisalpinus**).

**citō**, -āvi, -ātus, -āre, [**citō-** (stem of **citus**)], I. v. a., *urge on, hurry*.—**citātus**, -a, -um, p.p. as adj., *in haste*: **citatus fertur** (*runs at full speed*).

**citō** [abl. of **citus** (from **cieo**)], adv., *quickly*: **citissimē** (*very rapidly*).

**citrā** [abl. or instr.(?) of **citer**], adv. and prep., *this side, within* (as opposed to beyond).

**citrō** [dat. of **citer**], adv., *to this side*: **ultrō citroque** (*back and forth*).

**civis**, -is, [ $\sqrt{\text{CI}}$  (in **quies**) + **vis**

(weakening of **-vus**), C., *a citizen, a fellow-citizen*.

**civitās**, -tātis, [**civi** + **tas**], F., *the state of being a citizen, citizenship, the Roman franchise*.—Less exactly, *a body of fellow-citizens, the citizens* (as a body), *one's fellow-citizens, a state* (composed of citizens), *a city* (because the city was the state), *a nation, a tribe* (politically): **expellit ex civitate** (*from the country*).

**clam** [case of stem akin to **caligo**, etc.], adv. and prep., *secretly*.

**clāmitō**, -āvi, -ātus, -āre, [freq. of **clamo**, perh. †**clamita** (cf. **nauta**)], I. v. a., *keep crying out, vociferate, cry out*.

**clāmor**, ōris, [**clam** (as if root of **clamo**) + **or**], M., *a shouting, a shout, a cry, an outcry*.

**clandestīnus**, -a, -um, [unc. stem (perh. manufactured from **clam**) + **tinus**], adj., *secret, clandestine*.

**clārus**, -a, -um, [ $\sqrt{\text{CLA}}$  (in **clamo**) + **rus**], adj., *bright, clear*.—Fig., *famous*.—Also (of sound), *loud, distinct*.

**clāssis**, -is, [ $\sqrt{\text{CLA}}$  (in **clamo**) + **tis**], F., (*a summoning*).—Less exactly, *the army* (called out).—Esp., *an army* (called out for duty at sea), *a fleet* (the most common later meaning).

**Claudius**, -i, [**claudō**+**ius** (prop. adj.)], M., a Roman gentile name.—Esp., **Appius Claudius**, consul in B.C. 54.

**claudō**, **clausi**, **clausus**, **claudere**, [of unc. form., akin to **clavis**], 3. v. a., *close, shut, fasten*.—Esp., **claudere agmen** (*close the line of march, bring up the rear*).

**clausus**, -a, -um, p.p. of **claudo**.  
**clāvus**, -i, [ $\sqrt{\text{CLAU-}}$  (cf. **claudo**) + **us**], M., *a nail, spike*.

**clēmēns**, -entis, [perh.  $\sqrt{\text{CLA}}$  (in **clarus**) + **mens** (cf. **vehemens**)], adj., (*bright?*), *gentle* (of weather). — Fig., *gentle, kind, merciful*.

**clēmēntia**, -ae, [clement + ia], F., *kindness, gentleness, humanity, clemency*.

**cliēns**, -entis, [pres. p. of **clueo**], C., (*a hearer*), *a dependant, a vassal, a retainer*.

**clientēla**, -ae, [cliēnt + ēla (imitating **suadela**, etc.)], F., *vassalage* (as condition of a **cliēns**). Hence (viewed fr. the other side), *protection*. — Phrases: **magnae clientelae** (*many vassals*, extensive relations of "clientage"); **Remis in clientelam se dicaverunt** (*surrendered themselves as vassals to*, etc.).

**clivus**, -i, [ $\sqrt{\text{CLI}}$  (in **clino**) + **vus**], M., *a slope, a declivity, an acclivity*: **ad molliendum clivum** (*to make the ascent easier*).

**Clōdius**, -i, [the popular form of **Claudius**], M., a Roman gentile name, belonging to the plebeian branch of the gens **Claudia**. — Esp., **P. Clodius**, a most bitter enemy of **Cicero**. He was killed in a fray by **T. Annius Milo**, who was defended by **Cicero** in a famous oration still extant.

**Cn.**, abbreviation for **Cnacus**.

**Cnacus**, see **Gnaeus**.

**coacervō**, -āvī, -ātus, -āre, [con-acervo], 1. v. a., *heap up, mass together, heap on top* (of others).

**coāctus**, -a, -um, p.p. of **cogo**.

**coāctus**, -tūs, [con-actus (cf. **cogo**)], M., *compulsion*.

**coagmentō**, -āvī, -ātus, -āre, [coagmentō-], 1. v. a., *fasten together*.

**Cocosātes**, -um, [Celtic], M. plur., a people of **Aquitania**.

**coelestis**, see **caelestis**.

**coemō**, -ēmī, -emptus, -emere, [con-emo], 3. v. a., *buy up*.

**coeō**, -īvī, no p.p., -īre, [con-eo], irr. v. n., *come together, unite*.

**coepī**, -isse, [con-†api (perf. of †apo, cf. **apiscor**)], def. v. a., (*have taken hold of*), *began, undertook, started*. — **coeptus**, -a, -um, p.p. used in same sense as active with passive infinitives.

**coeptus**, -a, -um, p.p. of **coepī**.

**coerceō**, -ercuī, -ercitus, -ercēre, [con-arceo], 2. v. a., *confine, keep in check*.

**cōgitō**, -āvī, -ātus, -āre, [con-agito (in sense of *revolve, discuss*)], 1. v. a., *consider, think over*. — Esp. (as to some plan of action), *think about, discuss* (what to do), *have an idea of, intend, consider* (that something may happen), *expect* (contemplate the possibility): **cogitare ne** (*see that not, think how not, plan to prevent*); **nihil cogitare de bello** (*have no thought of*, etc.).

**cōgnātiō**, -ōnis, [con-(g)natio], F., *connection by birth*. — Concretely, *a family, a clan*: **magnae cognationes** (*extensive connections, by blood*).

**cōgnitus**, -a, -um, p.p. of **cognosco**.

**cōgnōscō**, -gnōvī, -gnitus, -gnōscere, [con(g)nosco], 3. v. a., *learn, find out, find, become aware*. — Esp., *investigate, inquire into, learn about, study*. — In perfect tenses (cf. **nosco**), *know, be aware*: **cognitum est de aliqua re** (*something was known*); **causa cognita** (*upon a full investigation, after trial*); **egregia virtute erant cogniti** (*had been found to be of*, etc.); **ad cognoscendum** (*for inquiry*).

**cōgō**, **coēgī**, **coāctus**, **cōgere**, [con-ago], 3. v. a., *bring together, collect, assemble, get together*. Hence, *force, compel, oblige*: **coactus** (*by compulsion*).

**cohors**, -hortis, [con-†hortis (reduced), akin to **hortus**], F., *an enclosure*. Hence, *a body of troops, a cohort* (the tenth part of a legion, corresponding as a unit of formation to the company of modern tactics, and containing from 300 to 600 men).

**cohortātiō**, -ōnis, [con-hortatio (cf. **cohortor**)], F., *an encouraging, encouragement*. — Esp. (to soldiers), *an address* (almost invariably a preliminary to an engagement).

**cohortor**, -ātus, -ārī, [con-hortor], 1. v. dep., *encourage, rally, address* (esp. of a commander).

**collātus**, see **conlatus**.

**collaudātiō**, see **conlaudatio**.

**collaudō**, see **conlaudo**.

**collectus**, see **conlectus**.

**colligō**, see **conligo**, 1 and 2.

**collis**, -is, [?], M., *a hill*.

**collocātus**, see **conlocatus**.

**collocō**, see **conloco**.

**colloquium**, see **conloquium**.

**colloquor**, see **conloquor**.

**colō**, **coluī**, **cultus**, **colere**, [?], 3. v. a., *till, cultivate*. — Fig., *attend upon, court, cultivate* (as a friend), *pay court to, worship* (of divinities).

**colōnia**, -ae, [colonō + ia], F., (*state of a colonist*). — Concretely, *a colony* (both of the establishment and the persons sent). The Roman colonists were and continued to be Roman citizens, and served as armed occupants of the soil where they were sent in the interests of the mother country.

**color**, -ōris, [prob. akin to **caligo**, as opposed to *white*], M., *color*.

**combūrō**, -ūssī, -ūstus, -ūrere, [con-†buro(?), relation to **uro** very uncertain, cf. **bustum**], 3. v. a., *burn up, consume*.

**comes**, -itis, [con-†mitis (√MA in meo + tis, cf. **semita**)], C., *a companion* (esp. an inferior as attendant or follower).

**cōminus** [formed by some false analogy from **con manus**], adv., *hand to hand* (cf. **ēminus**), *in close combat, at short range*.

**comitātus**, -a, -um, p.p. of **comitor**.

**comitium**, -ī, [?, perh. **comit-** (see **comes**) + **ium**, the assemblage of followers (cf. **servitium**)], N., a part of the Forum at Rome. — Plur., *an election* (assembly of the people for voting).

**comitor**, -ātus, -ārī, [comit-], 1. v. dep., *accompany*. — **comitātus**, -a, -um, p.p. in pres. sense, *accompanying*.

**commeātus**, -tūs, [con-meatus, cf. **commeo**], M., *a going to and fro, an expedition* (back and forth), *a trip*. Hence, *communications* (of an army). — So also, *supplies* (of an army), *provisions*.

**commemorō**, -āvī, -ātus, -are, [con-memoro], 1. v. a., *remind one of*. Hence, *speak of, mention, state* (in a narrative).

**commendō**, -āvī, -ātus, -āre, [con-mando], 1. v. a., *intrust, recommend, surrender*.

**commeō**, -āvī, -ātūrus, -āre, [con-meo], 1. v. n., *go back and forth*. — With **ad**, *visit, resort to*.

**commissūra**, -ae, [con-†missura (cf. **committo**)], F., *a joint*.

**commissus**, -a, -um, p.p. of **committo**.

**committō**, -mīsī, -missus, -mit-

tere, [con-mitto], 3. v. a., (*let go* (send) *together* or *altogether*). Hence *join, unite, attach*: *proelium* (*engage, begin the engagement*). — Also, *trust*: *se barbaris committere* (*put one's self in the hands of, etc.*); *nihil his committere* (*place no confidence in, etc.*). — Also, *admit, allow* (to happen), *commit* (suffer to be done, cf. *admitto*), *perpetrate*: *neque commissum a se* (*nothing had been done by them*); *committere ut posset* (*leave it possible*); *nihil committebant* (*did nothing*).

**Commius**, -ī, [Celtic], M., a leader of the Atrebrates.

**commodē** [abl. of **commodus**], adv., *advantageously, conveniently, fitly, readily, to advantage*: *satis commode* (*to much advantage*); *non satis commode* (*not very easily*).

**commodum**, see **commodus**.

**commodus**, -a, -um, [con-modus, see A. & G., 168 d], adj., (*having the same measure with*), *fitting, suitable, convenient, advantageous*: *commodissimum est* (*it is the best thing, most advantageous*). — Neut. as subst., *convenience, comfort, advantage, interest*: *commodo reipublicae* (*without prejudice to the public interests*); *omnibus in vita commodis* (*all the blessings of life*); *rei familiaris commodum* (*the interests of one's property*); *quas sui quisque commodi fecerat* (*for his own convenience*), see A. & G., 214 c.

**commonēfaciō**, -fēcī, -factus, -facere, [unc. case-form (of stem akin to **moneo**) -facio], 3. v. a., *remind*.

**commorātus**, -a, -um, p.p. of **commoror**.

**commoror**, -ātus, -ārī, [con-moror], 1. v. dep., *delay, stay*.

**commōtus**, -a, -um, p.p. of **commoveo**.

**commoveō**, -mōvī, -mōtus, -movēre, [con-moveo], 2. v. a., *move, stir, agitate*. — With reflex., or in pass., *be moved, move* (intrans.), *stir*. — Fig., *disturb, agitate, affect, alarm, influence* (with idea of violent feeling).

**commūnicātus**, -a, -um, p.p. of **communico**.

**commūnicō**, -āvī, -ātus, -āre, [†communico- (stem of †communicus, communi + cus)], 1. v. a., (*make common*), *share, communicate, consult* (with a person about a thing, and so make it common), *add* (a thing to another), *put in along with* (something else).

**commūniō**, -īvī, -ītus, -īre, [communio], 4. v. a., *fortify, intrench, build* (make by fortification).

**commūnis**, -e, [con + munis (cf. **munia**, *duties*)], adj., (*having shares together*), *common, general, in common*: *ex communi consensu* (*by general agreement*); *consilium* (*general plan, concerted action*).

**commūtātiō**, -ōnis, [con-mutatio (cf. **commuto**)], F., *change*: *aestus* (*turn*).

**commūtātus**, -a, -um, p.p. of **commuto**.

**commūtō**, -āvī, -ātus, -āre, [con-muto], 1. v. a., *change, exchange*: *studium belli agriculturā* (*exchange the pursuits of war for agriculture*).

**comparātus**, -a, -um, p.p. of 1. **comparo**.

1. **comparō**, -āvī, -ātus, -āre, [comparo], 1. v. a., *get ready, prepare, procure, gain, get together, prepare for* (with a different view of the object in English): *omnibus rebus*

comparatis (*having made all arrangements*).

2. **comparō**, -āvi, -ātus, -āre, [con-**paro**], 1. v. a., (*pair together*), *compare*.

**compellō**, -puli, -pulsus, -pellere, [con-**pello**], 3. v. a., (*drive together* (or *altogether*), *drive in*, *force*, *drive*).

**compendium**, -i, [com + **pendium**], N., (*a weighing in*, cf. **expendo**), *a saving*, *profit*.

**comperiō**, -peri, -pertus, -perire, [con-**pario**], 4. v. a., (*get together*), *find out* (by inquiry), *discover*. — **compertus**, -a, -um, p.p. as adj., *certain* (cf. **exploratus**).

**compertus**, -a, -um, p.p. of **comperio**.

**complector**, -plexus, -plecti, [con-**plector**], 3. v. dep., *embrace*, *include*, *enclose*.

**compleō**, -plēvi, -plētus, -plēre, [con-**pleo**], 2. v. a., *fill up*, *fill*. — With a different conception of the action from Eng., *cover*, *man* (of walls).

**complexus**, -a, -um, p.p. of **complector**.

**complūrēs**, -plūra (-ia), [con-**plus**], adj. plur., *very many*, *a great many*, *a great number of*.

**comportō**, -āvi, -ātus, -āre, [con-**porto**], 1. v. a., *bring together*.

**comprehendō**, -hendī, -hēnsus, -hendere, [con-**prehendo**], 3. v. a., *seize*, *catch*, *arrest*, *capture*, *grasp* (one by the hand or clothing). — Fig., *take*, *catch* (of fire).

**comprehēnsus**, -a, -um, p.p. of **comprehendo**.

**comprobō**, -āvi, -ātus, -āre, [con-**probo**], 1. v. a., *prove*, *approve*: **consilium fortuna** (*justify*).

**compulsus**, -a, -um, p.p. of **compello**.

**cōnātum**, -i, [N. p.p. of **conor** as pass.], N., *an attempt*, *an undertaking*.

**cōnātus**, -tūs, [conā- (stem of **conor**) + **tus**], M., *an attempt*, *an effort*.

**cōnātus**, -a, -um, p.p. of **conor**. **concedō**, -cēssi, -cēssus, -cēdere, [con-**cedo**], 3. v. a. and n., (*give up a thing to one*), *allow*, *grant*, *assign* (leave, where the rest is taken away), *permit*, *yield the palm* (to a superior), *yield*, *make a concession*.

**concertō**, -āvi, -ātūrus, -āre, [con-**certo**], 1. v. n., *contend*.

**concessus**, -sūs, [con-†**cessus** (cf. **concedo**)], M., *a concession*, *a permission*.

**concidō**, -cidi, -cāsūrus, -cidere, [con-**cado**], 3. v. n., *fall down*, *fall*.

**concidō**, -cidi, -cīsus, -cidere, [con-**caedo**], 3. v. a., *cut to pieces*, *cut down* (kill), *cut up* (land by estuaries).

**conciliō**, -āvi, -ātus, -āre, [con-**ciliō**- (stem of **concilium**)], 1. v. a., *bring together* (cf. **concilium**). Hence, *win over* (originally by persuasion in council?), *secure* (even by force), *win*, *gain*.

**concilium**, -i, [con-†**cilium** (√CAL + **ium**, cf. **Calendae**)], N., *a meeting*. — Esp., *an assembly* (of war or state), *a council*, *a conference*: **per concilium** (*in council*).

**conciō**, see **contio**.

**concius**, -a, -um, p.p. of **conciō**.

**concitātus**, -a, -um, p.p. of **concito**.

**concitō**, -āvi, -ātus, -āre, [con-**cito**], 1. v. a., *arouse*, *stir up*, *call out* (and so set in motion).

**conclāmātus**, -a, -um, p.p. of **conclamo**.

**conclāmō**, -āvi, -ātus, -āre, [con-clamo], 1. v. n., *cry out, shout: victoriam* (cogn. acc.), *shout victory*.

**conclūdō**, -clūsi, -clūsus, -clūdere, [con-claudo], 3. v. a., *shut up, enclose: mare conclusum* (enclosed, inland).

**conclūsus**, -a, -um, p.p. of **concludo**.

**Conconetodumnus**, see **Conetodumnus**.

**conerepō**, -crepui, -crepiturus, -crepāre, [con-crepo], 1. v. n., *rattle, clash: armis* (clash their arms, of soldiers).

**concurrō**, -curri (-cucurri), -cur-surus, -currere, [con-curro], 3. v. n., *run together, rush up, rush in, rush* (advance), *flock to, hasten in: concursum est* (there was a rush).

**concurso**, -āvi, -āturus, -āre, [con-curso], 1. v. n., *rush to and fro: concursari iubet* (orders a noise of running to and fro to be made).

**concursum**, -a, -um, p.p. of **concurro**.

**concursum**, -sūs, [con-cursus (cf. **concurro**)], M., *a rushing to and fro, a dashing together* (collision).—Esp., *a charge, onset, a crowd running, a crowd*.

**condemnātus**, -a, -um, p.p. of **condemno**.

**condemnō**, -āvi, -ātus, -āre, [condamno], 1. v. a., *condemn, find guilty*.

**condiciō**, -ōnis, [con-dicio (cf. **condico**)], F., *terms, condition, terms of agreement, terms* (of fighting), *state* (of slavery): *ad iniquam condicionem pugnandi* (to fight on unequal terms).

**conditiō**, see **condicio**.

**condōnō**, -āvi, -ātus, -āre, [con-

**dono**], 1. v. a., *give up, pardon for the sake of*.

**Condūsī**, -ōrum, [Celtic], M. pl., a Belgic tribe on the Meuse, clients of the Treveri.

**condūcō**, -dūxi, -ductus, -dūcere, [con-duco], 3. v. a., *bring together, bring up* (soldiers), *hire: manus conducta* (a band of mercenaries).

**Conetodumnus** (**Conconet-**), -ī, [Celtic], M., a leader of the Carnutes.

**cōnfectus**, -a, -um, p.p. of **conficio**.

**cōnferciō**, -fersi, -fertus, -fercire, [con-farcio], 4. v. a., *crowd together*.—**cōnferthus**, -a, -um, p.p. as adj., *close, crowded, dense, closely crowded, in close order, in a solid body*.

**cōnferō**, -tuli, -lātus, -ferre, [con-fero], irr. v. a., *bring together, get together, bring in, gather, collect*.—With or without **culpam**, *lay the blame on, charge*.—With reflexive, *betake one's self, remove, take refuge*.—So with other words, *fortunas* (remove).—Also, *postpone, delay*.

**cōnferthus**, -a, -um, p.p. of **conficio**.

**cōnfestim** [acc. of †con-festis (cf. **festino**)], adv., *in haste, immediately, at once*.

**cōnficiō**, -fēcī, -fectus, -ficere, [con-facio], 3. v. a., (*do up*), *accomplish, complete, finish up, carry out, finish, perform*.—Also, *make up, write up* (of a document), *work up* (of skins tanned).—Also (cf. Eng. "done up"), *finish up, exhaust, wear out: nondum confecta hieme* (when the winter was not yet spent, before the end of, etc.).—See also **confio**.

**cōnfidō**, -fīsus sum, -fidere, [con-fido], 3. v. n., *be confident, trust,*



*trust to, have confidence in, rely on, feel assured.* — **cōnfisus**, -a, -um, p.p. in active sense, *trusting in*.

**cōnfigō**, -fixī, -fixus, -figere, [con-figo], 3. v. a., *fasten together, fasten*.

**cōnfinis**, -e, [con-finis], adj., (*having boundaries together, see A. & G., 168 d*), *adjacent*: **confines** **Senonibus** (*neighbors of*).

**cōnfinium**, -ī, [confini + ium], N., *neighborhood, confines (common boundaries)*.

**cōnfiō**, -fieri, -fectus, [con-fio], irr. v. n. (used rarely as pass. of **conficio**), *be accomplished, etc. (see conficio)*.

**cōnfirmātiō**, -ōnis, [con-firma-tio, cf. **confirmo**], F., *assurance, confirmation*.

**cōnfirmātus**, -a, -um, p.p. of **confirmo**.

**cōnfirmō**, -āvi, -ātus, -āre, [con-firmo], 1. v. a., *strengthen*. — Fig., *strengthen, establish (pacem), reassure, encourage, confirm, assure (by oath): se (resolve)*. Hence (of things and statements), *confirm, declare*.

**cōnfisus**, -a, -um, p.p. of **confido**.

**cōnfiteor**, -fessus, -fitēri, [con-fateor], 2. v. dep., *confess, acknowledge, admit*.

**cōnfixus**, -a, -um, p.p. of **configo**.

**cōnflagrō**, -āvi, -ātus, -āre, [con-flagro], 1. v. n., *be on fire, burn*.

**cōnflctātus**, -a, -um, p.p. of **conflicto**.

**cōnflctō**, -āvi, -ātus, -āre, [con-†flctio, cf. **confligo**], 1. v. a., *dash against (one thing against another), assail*.

**cōnfligō**, -flixī, -flictus, -fligere, [con-fligo], 3. v. a. and n., *dash against, contend, fight*.

**cōnfluēns**, -entis, [pres. p. of **confluo**], M., *a meeting of two rivers, confluence*.

**cōnfluō**, -fluxī, no p.p., -ere, [con-fluo], 3. v. n., *flow together*. — Less exactly (of persons), *flock together*.

**cōn fugiō**, -fūgī, no p.p., -fugere, [con-fugio], 3. v. n., *flee, take refuge*.

**cōn fundō**, -fūdī, -fūsus, -fundere, [con-fundo], 3. v. a., *pour together*. — Less exactly, *mingle, mix indiscriminately, unite without distinction*.

**congerō**, -gessī, -gestus, -gerere, [con-gero], 3. v. a., *bring together, heap together*.

**congregior**, -gressus, -gredi, [con-gradior], 3. v. dep., *come together*. — In peace, *unite with*. — Esp. in war, *come in contact with, engage, fight*.

**congressus**, -a, -um, p.p. of **congregior**.

**congressus**, -sūs, [con-gressus, cf. **congregior**], M., *an engagement*.

**cōnicio** (-jicio), -jēcī, -jectus, -icere, [con-iacio], 3. v. a., *throw together, hurl, cast, discharge: se conicere (throw one's self, rush)*. — Less exactly (esp. in a military sense), *throw (into prison), put, place, station (cf. military throw troops into, etc.), force*. — Fig., *put together (of ideas)*.

**conjectūra**, -ae, [con-iactura, cf. **conicio**], F., *a guess ("putting two and two together"), a conjecture*.

**conjectus**, -a, -um, p.p. of **conicio**.

**conjiciō**, see **conicio**.

**conjunctim** [acc. of †**conjunctis** (jung as root + tis, cf. **conjungo**)], adv., *unitedly, in common, altogether*.

**conjunctus**, -a, -um, p.p. of **conjungo**.

**conjungō**, -jungī, -junctus, -jungere, [con-jungo], 3. v. a., *unite, connect, fasten together*. — In pass., or with reflexive, *unite* (neuter), *connect one's self, join*. — **conjunctus**, -a, -um, p.p. as adj., *united, closely connected*.

**conjunx**, -jugis, [con-tjux (√JUG, as stem, with intrusive n from jungo)], C., *a spouse*. — Esp., F., *a wife*.

**conjurātiō**, -ōnis, [conjuratio, cf. **conjuro**], F., *a conspiracy, a confederacy*.

**conjūrō**, -āvī, -ātus, -āre, [con-iuro], 1. v. n., *swear together, take an oath* (together), *swear mutual oaths*. Hence, *conspire*.

**conlātus** (coll-), -a, -um, p.p. of **confero**.

**conlaudātus** (coll-), -a, -um, p.p. of **conlaudo**.

**conlaudō** (coll-), -āvī, -ātus, -āre, [con-laudo], 1. v. a., *praise* (in set terms).

**conlētus** (coll-), -a, -um, p.p. of **conligo**.

**conligō** (coll-), -lēgī, -lēctus, -lēgere, [con-lego], 3. v. a., *gather, collect, acquire* (by accumulation). — With reflexive, *collect one's self, recover*.

**conligō** (coll-), -āvī, -ātus, -āre, [con-ligo], 1. v. a., *bind together, fasten together*: *scuta* (*lock together*).

**conlocātus** (coll-), -a, -um, p.p. of **conloco**.

**conlocō**, -āvī, -ātus, -āre, [con-loco], 1. v. a., *place, set, station* (of troops, etc.): *angustius milites* (*stow, in a vessel*). — Esp. (with or without **nuptum**), *give in marriage, marry* (of a father or guardian). — Fig., *settle*: *rebus conlocandis* (*making dispositions*).

**conloquium** (coll-), -ī, [con-†loquium, cf. **conloquor**], N., *a conference, an interview, a parley*.

**conloquor** (coll-), -locūtus, -loqui, [con-loquor], 3. v. dep., *confer, hold an interview* (or *parley*), *parley, converse*.

**cōnor**, -ātus, -ārī, [? con-, stem akin to **onus**], 1. v. dep., *attempt, try, endeavor*: *idem conari* (*make the same attempt*).

**conquiescō**, -quievī, -quietūrus, -quiescere, [con-quiesco], 3. v. n., *rest, repose*.

**conquīrō**, -quīsivī, -quīsitus, -quīrere, [con-quaero], 3. v. a., *search for, seek for, hunt up*.

**cōsanguineus**, -a, -um, [con-sanguin + eus], adj., *akin* (by blood). — As subst., *a kinsman*.

**cōnscondō**, -scendī, -scēnsus, -scendere, [con-scando], 3. v. a., *climb, climb upon*: *naves* (*in naves*) (*go on board*); *vallum* (*man*).

**cōnscentia**, -ae, [con-scientia, cf. **consciens**], F., *consciousness, privity, conscience*.

**cōnsēscō**, -scivī, -scītus, -sciscere, [con-scisco], 3. v. a., *resolve* (a political term, cf. **plebiscitum**). — Less exactly, with dat. of reflex., *take to one's self*: *mortem* (*commit suicide*).

**cōnsciens**, -a, -um, [con-†sciens, √SCI (in scio) + us], adj., *knowing* (with one's self or another), *conscious*.

**cōnserībō**, -scripsī, -scriptus, -scribere, [con-scribo], 3. v. a., *write down*. — Esp., *enrol, conscribe, levy*.

**conscriptus**, -a, -um, p.p. of **conscribo**.

**cōnsecrātus**, -a, -um, p.p. of **consecro**.

**consecrō**, -āvi, -ātus, -āre, [con-sacro], I. v. a., *hallow, consecrate*. — **cōnsecrātus**, -a, -um, p.p. as adj., *consecrated, sacred*.

**cōnsector**, -ātus, -ārī, [con-sec-tor, cf. **consequor**], I. v. dep., *overtake*.

**cōnsecūtus**, -a, -um, p.p. of **consequor**.

**cōnsēnsiō**, -ōnis, [con-†sēnsio, cf. **consentio**], F., *agreement, unanimity*.

**cōnsēnsus**, -sūs, [con-sensus, cf. **consentio**], M., *agreement, consent, harmonious (or concerted) action*.

**cōnsentiō**, -sēnsī, -sēnsūrus, -sentire, [con-sentio], 4. v. n., *agree, conspire, make common cause, act with (some one)*.

**cōnsequor**, -secūtus, -sequī, [con-sequor], 3. v. dep., *follow (and stay with), overtake*. Hence, *obtain, secure, attain, succeed in (some purpose)*. — Also, *follow close upon, succeed, ensue*.

**cōnservō**, -āvi, -ātus, -āre, [con-servo], I. v. a., *save, preserve, spare*. — Also, *observe (law, right), regard*.

**Cōnsidius**, -ī, [con-†sidius (akin to **sedeo**)], a Roman name. — Esp., *Publius*, a Roman soldier.

**cōnsidō**, -sēdī, -sessūrus, -sīdere, [con-sido], 3. v. n., *sit down (in a place)*. — Less exactly, *take a position, halt, encamp, settle*.

**cōnsilium**, -ī, [con-†silium (cf. **consul**, akin to **salio**, in some earlier unc. meaning)], N., *deliberation, a council (of war, more commonly **concilium**)*. — Esp., *wise counsel, prudence, discretion*. Hence, *a plan, counsel, design, purpose*. — And so (design carried out), *course, measure, conduct*. — Phrases: **ipsorum esse consilium** (*a matter for them*

*to decide*); **quasi consilii sit res** (*as if it were a matter for consultation*); **commune consilium** (*concerted action*); **publicum consilium** (*action of the state, official action*); **barbaris consilium non defuit** (*an intelligent plan of action*).

**cōnsimilis**, -e, [con-similis], adj., *very like, just like*.

**cōnsistō**, -stitī, no p.p., -sistere, [con-sisto], 3. v. n., *take a stand, take a position, stand, keep one's position, form (of troops)*. — In perf. tenses, *have a position, stand*. Hence, *stop, halt, make a stand, hold one's ground, run aground (of ships), remain, stay*. — With **in**, *occupy, rest on*. — Fig., *depend on, rest on*.

**cōnsobrīnus**, -ī, [con-sobrinus], M., *first cousin (on the mother's side)*. — Less exactly, (any) *cousin german*.

**cōnsōlātus**, -a, -um, p.p. of **consolor**.

**cōnsōlor**, -ātus, -ārī, [con-solor], I. v. dep., *console*. — **cōnsōlātus**, -a, -um, p.p. as pres., *consoling*.

**cōnspectus**, -a, -um, p.p. of **conspicio**.

**cōnspectus**, -tūs, [con-spectus, cf. **conspicio**], M., *sight*. — in **conspectu** (*in one's presence*); in **conspectum proferre** (*display*).

**cōnspicātus**, -a, -um, p.p. of **conspicor**.

**cōnspiciō**, -spexī, -spectus, -spicere, [con-specio], 3. v. a., *catch sight of, espy*.

**cōnspicor**, -ātus, -ārī, [†conspic-, cf. **auspex**], I. v. dep., *catch sight of, espy, see*.

**cōnspirō**, -āvi, -ātus, -āre, [con-spiro], I. v. n., *sound together*. — Fig., *harmonize*. — Also, *conspire, league together*.

**cōnstanter** [constant + ter], adv., *consistently, uniformly, steadily, with constancy, firmly.*

**cōnstantia**, -ae, [constant + ia], F., *firmness, constancy, undaunted courage.*

**cōnsternātus**, -a, -um, p.p. of **consterno**.

**cōnsternō**, -āvī, -ātus, -āre, [con-†sternō (cf. sternax)], I. v. a., *overwhelm.* -Fig., *dismay.*—**cōnsternātus**, -a, -um, p.p., *stricken with fear.*

**cōnsternō**, -strāvī, -strātus, -sternere, [con-sterno], 3. v. a., *strew over* (both of the thing thrown and that over which): **navis constrata** (*decked, full decked*, as opposed to ships only covered at the ends).

**cōnstipō**, -āvī, -ātus, -āre, [con-stipo], I. v. a., *crowd, cram.*—In pass. or with reflexive, *crowd together.*

**cōnstituō**, -stitui, -stitūtus, -stituire, [con-statuo], 3. v. a. and n., *set up, raise, put together, make up.* Hence, *establish, station, arrange, draw up (aciem).*—Fig., *determine, appoint, agree upon, determine upon, fix, decide upon*: **praemia** (*offer*).

**cōnstō**, -stiti, -stāturus, -stāre, [con-sto], I. v. n., *stand together.*—Fig., *agree* (esp. of accounts): **numerus** (*be complete*). Hence, *be established, appear, be agreed upon, be evident.*—Also (from accounts), *cost.*—Also (with in), *depend upon.*

**cōnstrātus**, -a, -um, p.p. of **consterno**.

**cōnsuēscō**, -suēvī, -suētus, -suēscere, [con-suesco], 3. v. n., *become accustomed.*—In perf. tenses, *be accustomed, be wont.*—**cōnsuētus**, -a, -um, p.p., *accustomed, wont, used.*

**cōnsuētūdō**, -inis, [con-†suetudo (prob. †suetu + do, as in **gravēdo, libīdo**), cf. **consuesco**], F.,

*habit, custom, habits* (collectively), *manners, customs*: **victus** (*customary mode of living*); **itineris** (*usual manner of marching*).

**cōnsuētus**, -a, -um, p.p. of **consuesco**.

**cōnsul**, -ulis, [con-sul (cf. **prae-sul, exsul**), root of **salio** in some earlier unc. meaning], M., *a consul* (the title of the chief magistrate of Rome, cf. **consilium**).—With proper names in abl., the usual way of indicating dates: **M. Messala et M. Pisone consulibus** (*in the consulship of, etc.*); **se consule** (*in his consulship, as a date or occasion*).

**cōnsulātus**, -tūs, [†consulā- (cf. **exsulo**) + tus], M., *consulship* (cf. **consul**).

**cōnsulō**, -suluī, -sultus, -sulere, [prob. **consul**, though poss. a kindred or independent verb], 3. v. a. and n., *deliberate, consult, take counsel, decide.*—With acc., *consult, take the advice of.*—With dat., *take counsel for, consult the interests of, consult for the welfare of, look out for, do a service to*: **vitae** (*spare*).—Phrase: **sortibus consultum** (**est**), (*lots were drawn to decide*).

**cōnsultō**, -āvī, -ātus, -āre, [con-sultō-], I. v. n., *consult*: **de bello** (*take measures for*).

**cōnsultō** [prob. like abl. absolute used impersonally, cf. **auspicato**], adv., *with deliberation, purposely, designedly.*

**cōnsultum**, -ī, [N. p.p. of **consulo**], N., *a decision, an order, a decree.*—Esp., **senatus consultum** (*an order of the senate*).

**cōnsūmō**, -sūmpsi, -sūmptus, -sūmere, [con-sumo], 3. v. a., (*take out of the general store*). Hence, *waste, consume, destroy, spend, exhaust.*

**cōnsūmptus**, -a, -um, p.p. of **consumo**.

**cōnsurgō**, -surrēxī, -surrectus, -surgere, [con-surgo], 3. v. n., *rise, rise up*. — Esp. of a session, *break up*.

**contabulō**, -āvi, -ātus, -āre, [contabulo], 1. v. a., *build up* (in stories). — Also, *build up* (generally, as of a wall with towers).

**contāgiō**, -ōnis, [con-†tagio, cf. **contingo**], F., *contact*. — Esp. with something noxious, implying *contagion*.

**contāminātus**, a, -um, p.p. of **contamino**.

**contāminō**, -āvi, -ātus, -āre, [contamin- (stem of con-tāmen, i.e. tag + men)], 1. v. a., *bring into contact, unite*. — Esp. with notion of contagion (cf. **contagio**), *contaminate*: **facinore contaminatus** (*implicated in*).

**contegō**, -tēxī, -tectus, -tegere, [con-tego], 3. v. a., *cover up*.

**contemnō**, -temp̄sī, -temptus, -temnere, [con-temno], 3. v. a., *despise, disregard, hold in contempt*.

**contemptiō**, -ōnis, [con-†temptio, cf. **contemno**], F., *contempt*: **in contemptionem venire** (*incur the contempt, etc.*).

**contemptus**, -tūs, [con-†temptus, cf. **contemno**], M., *contempt, scorn*: **contemptui est** (*is a matter of ridicule*).

**contendō**, -tendī, -tentus, -tendere, [con-tendo], 3. v. n., *strain, struggle, strive, try, endeavor, exert one's self, attempt, be zealous*: **id contendere et laborare** (*strive and exert one's self for that*). — Esp. with verbs of motion, *press on, hasten*. — Also, *fight, contend, wage war*. — With **ad** and in like constructions,

*hasten, march, start to go* (in haste): **vi contendere** (*to force a passage*); **petere contendit** (*seek earnestly*).

**contentiō**, -ōnis, [con-†tentiō, cf. **contendo**], F., *struggle, efforts*. — Esp., *contest, fighting*.

**contendens**, -a, -um, p.p. of **contendo** and **contineo**.

**contestātus**, -a, -um, p.p. of **contestor**.

**contestor**, -ātus, -ārī, [con-tes-  
tor], 1. v. dep., *call to witness*.

**contexō**, -texuī, -textum, -texere, [con-texo], 3. v. a., *interweave, weave together*. — Also, *weave* (make by weaving).

**contextus**, -a, -um, p.p. of **contexo**.

**continēns**, -entis, pres. p. of **contineo**, which see.

**continenter** [continent + ter], adv., *continually, without stopping, continuously*.

**continentia**, -ae, [continent + ia], F., *self-restraint*.

**contineō**, -tinuī, -tentus, -tinēre. [con-teneo], 2. v. a., *hold together, hold in*. Hence, in many fig. meanings, *restrain, hold in check, keep* (within bounds), *hem in, retain* (in something). — Pass. or with reflex., *keep within, remain, be included in, be bounded, consist in* (be contained in). — Also, *hold on to, join*. — **continēns**, -entis, pres. p. as adj., (*holding together*), *continual, contiguous, continuous*: **continenti impetu** (*with one continuous rush*). — As subst., *the continuous land, the continent*. — Also, *restraining one's self, continent*.

**contingō**, -tigi, -tactus, -tingere, [con-tango], 3. v. a. and n., *touch, reach, join*. — With dat., *happen*.

**continuātiō**, -ōnis, [continuā-

(see **continuō**) + **tio**], F., *continuation*: **continuatio imbrum** (*incessant rains*).

**continuō** [abl. of **continuus**], adv., *immediately, straightway, forthwith*.

**continuus**, -a, -um, [con-†**tenuus** (√TEN in **teneo** + **uus**)], adj., *continuous, successive*: **dies** (*successive*).

**contio**, -ōnis, [prob. for **conventio**], F., *an assembly*. — Less exactly, *an address* (to an assembly or to soldiers).

**contionātus**, -a, -um, p.p. of **contionor**.

**contionor**, -ātus, -ārī, [contion-], i. v. dep., *harangue, address* (an assembly or an army).

**contrā** [unc. case-form (instr.?) of †**conterus** (con + **terus**), cf. **superus, supra**], adv. and prep., *opposite, contrary to, against, in opposition, on the other hand*: **contrā atque** (*contrary to what, etc.*).

**contrahō**, -traxī, -trāctus, -trahere, [con-**traho**], 3. v. a., *draw together, draw in, bring together, gather together, contract, narrow, make smaller, bring into smaller compass*.

**contrārius**, -a, -um, [†**conterō** (see **contra**) + **arius**], adj., *opposite* (lit. and fig.), *contrary*: **ex contrario** (*on the contrary*); **in contrariam partem** (*in the opposite direction*).

**contrōversia**, -ae, [controversō + **ia**], F., *a dispute, a quarrel*. — Plur., *grounds of quarrel*.

**contumēlia**, -ae, [unc. form., akin to **contumax** and **tumeo**], F., (*swelling pride?*) — Fig., *violence* (of waves). — *affront*. — Fig., *outrage* (an insult, an affront).

**convalescō**, -valūī, no p.p., -valēscere, [con-†**valesco**], 3. v. n., *recover, get well*.

**convallis**, -is, [con-**vallis**], F., *a valley* (enclosed on all sides). — Less exactly, *a defile, a valley* (of any kind).

**convectus**, -a, -um, p.p. of **conveho**.

**convehō**, -vexī, -vectus, -vehere, [con-**veho**], 3. v. a., *bring together, bring in*.

**conveniō**, -vēnī, -ventus, -venire, [con-**venio**], 4. v. a. and n., *come together, meet, assemble, come in, arrive, agree upon, agree*. — With acc., *meet, come to*. — Also, of things, *be agreed upon, be fitting, be necessary* (in a loose sense in Eng.).

**conventus**, -tūs, [con-†**ventus** (cf. **convenio** and **adventus**)], M., *an assembly, a meeting*. — Esp., *an assize* (the regular assembly of Roman citizens in a provincial town on stated occasions, at which justice was dispensed).

**conversus**, -a, -um, p.p. of **converto**.

**convertō**, -vertī, -versus, -vertere, [con-**verto**], 3. v. a., *turn about, turn*. — Fig., *change*: **signa** (*change front, wheel*); **conversa signa bipartio intulerunt** (*wheeled and charged the enemy in two directions*); **conversa signa in hostes inferre** (*face about and charge, etc.*); **in fugam conversa** (*put to flight*); **conversam** [**materiam**] **ad hostem collocabat** (*placed [fallen trees] with their tops towards the enemy*); **contra vim fluminis** (*against the current*); **itinere converso** (*altering his course*); **mentes conversae sunt** (*their state of mind was changed*).

**Convictolitāvis**, -is, [Celtic], M., a young Hæduan nobleman.

**convictus**, -a, -um, p.p. of **convinco**.

**convincō**, -vīcī, -victus, -vincere, [con-vinco], 3. v. a., *prove, make good* (a charge, etc.): **avaritia convicta** (*found guilty of avarice*, changing the point of view for the Eng. idiom).

**convocō**, -āvī, -ātus, -āre, [convoco], 1. v. a., *call together, summon, call* (a council).

**coorior**, -ortus, -orīrī, [con-orior], 3. v. dep., *arise, spring up, break out* (of a war).

**coortus**, -a, -um, p.p. of **coorior**.

**cōpia**, -ae, [cōpi- (con-ops) + ia, cf. **inopia, inops**], F., *abundance, plenty, supply* (both great and small), *quantity, number*. — Esp., *luxury* (abundance of everything). — Plur. (esp. of forces), *forces, resources, supplies*. — Phrases: **copiam facere** (*afford a supply, give an opportunity*); **magna copia locorum** (*choice*); **copia atque usus** (*necessary supplies*).

**cōpiōsus**, -a, -um, [copia (reduced) + osus], adj., *well supplied, wealthy*.

**cōpula**, -ae, [con-+apula (from √AP, cf. **querulus**)], F., (*holding together*), *a grappling-hook*.

**cor**, cordis, [root as stem (akin to Eng. *heart*)], N., *the heart*. — Phrase: **cordi esse** (*be dear*).

**cōram** [unc. case, formed from **con** and **os**], adv. and prep., *present, in person*.

**corium**, -ī, [?], N., *a hide, a skin*.

**cornū**, -ūs, [?], N., *a horn*. — Fig., *a wing* (of an army).

**corōna**, -ae, [?], F., *a garland*. — Fig., *a circle (line, of soldiers)*. — Phrase: **sub corona** (*at auction, the garland being the symbol of a captive for sale at auction*).

**corpus**, -oris, [unc. root + us], N., *the body, the person*. — Also, *a body* (dead). — Less exactly, *extent* (of a camp). — Phrase: **magnitudo corporis** (*size*).

**corrumpō**, -rūpī, -ruptus, -rumperere, [con-rumpo], 3. v. a., *spoil, ruin*.

**cortex**, -icis, [?], M. (also F.), *bark*.

**Cōrus (Caurus)**, -ī, [?], M., *the north-west wind*.

**cotidiānus (quo-)**, -a, -um, [cotidie + anus], adj., *daily*: **cotidiano labore**.

**cotidiē (quot-)**, [quot-die, loc of dies], adv., *daily, every day*.

**Cotta**, -ae, [?], M., a Roman family name. — Esp., *Lucius Aurunculeius Cotta*, one of Cæsar's legati in Gaul.

**Cotuātus**, -ī, [?], M., (a doubtful reading), a chief of the Carnutes.

**Cotus**, -ī, [Celtic], M., a young Hæduan nobleman.

**crassitūdō**, -inis, [crassō + tūdo (as if **crassitu** + do), cf. **consuetudo**], F., *thickness*.

**Crassus**, -ī, [crassus, fat], M., a Roman family name. — Esp.: 1. *Marcus (Licinius) Crassus*, consul with Pompey, B.C. 55; one (with Cæsar and Pompey) of the combination called the Triumvirate. — 2. *Publius Crassus* (called *Adulescens, the Younger*, only as distinguished from his father), son of the Triumvir, serving with Cæsar in Gaul as commander of cavalry. — 3. *Marcus Crassus*, another son of the Triumvir, quæstor, B.C. 54, in Cæsar's army.

**crātēs**, -is, [?], F., *a hurdle, a fascine* (a hurdle used to hold up earthworks in fortification). — Also, *wicker* (for hurdles).

**creātus**, -a, -um, p.p. of **creo**.

**crēber**, -bra, -brum, [crē- (in **creo**) + **ber** (cf. **saluber**)], adj., *thick, close, numerous, frequent*: **arbores** (*thickly growing*); **praesidia** (*continuous, not far apart, at short intervals*).

**crēbrō** [prob. abl. of **creber**], adv., *frequently, constantly, in rapid succession, at short intervals*.

**crēdō**, crēdidī, crēditus, crēdere, [†**cred** (*faith*, of unc. formation) + **do** (*place*)], 3. v. a. and n., *trust, entrust, believe, suppose*.

**eremō**, -āvī, -ātus, -āre, [?], I. v. a., *burn, consume*.

**creō**, -āvī, -ātus, -āre, [unc. form., akin to **creasco**], I. v. a., (*cause to grow*), *create*. — Esp., *elect, choose*.

**Crēs**, **Crētis**, [Gr. Κρής], M., *a Cretan*.

**crēscō**, crēvī, crētus, crēscere, [stem crē (also in **creo**) with -**seo**], 3. v. n., *grow, increase, swell* (of a river), *be swelled, increase in influence* (of a man).

**crīmen**, -minis, [crī- (stem akin to **cerno**) + **men**], N., (*a decision*). — Less exactly, *a charge, a fault, a crime*.

**crīnis**, -is, [?], M., *the hair*.

**Critōgnātus**, -ī, [Celtic], M., *a chief of the Arverni*.

**cruciātus**, -tūs, [cruciā- (stem of **crucio**) + **tus**], M., *crucifying*. Hence, *torture*. — With a change of relation, *suffering* (of the person tortured).

**crūdēlis**, -es, [†**crudē** (in **crudescio**, akin to **crudus**) + **lis**, cf. **Aprīlis**, **edūlis**, **animālis**], adj., (*bloody?*), *cruel*.

**crūdēlītās**, -tātis, [crudeli + **tas**]. F., *cruelly*.

**crūdēlīter** [crudeli + **ter**], adv., *cruelly, with cruelty*.

**crūs**, crūris, [?], N., *the leg*.

**cubīle**, -is, [†**cubī**- (stem akin to **cumbo**) + **lis** (cf. **crudelis**)], N. of adj., N., *a couch, a resting-place, a bed, a lair*.

**cūjusque modī**, see **quisque** and **modus**.

**culmen**, -inis, [unc. root (in **cello**?) + **men**], N., *a height, a top, a summit, a roof*.

**culpa**, -ae, [?], F., *a fault, blame, guilt*.

**cultus**, -tūs, [√**COL** (in **colo**) + **tus**], M., *cultivation*. — Esp. of one's self, *care* (**corporis**). Hence, *civilization, manner of life, state of civilization*.

**cum** [? another form of **con**], prep., *with*.

**cum** (**quom**), [case-form (prob. acc.) of **qui**], conj., *when, while, whenever*. — Often rendered by a different construction in Eng.: **cum non posent** (*not being able*); **cum prohibent** (*while defending*). — Of logical relations (usually with subj.), *when, while, since, inasmuch as, though, although*: **cum . . . tum** (*while . . . so also*); **cum . . . tum maxime** (*not only . . . but especially*).

**cunctātiō**, -ōnis, [cunctā (stem of **cunctor**) + **tio**], F., *hesitation, reluctance, indisposition to fight*.

**cunctor**, -ātus, -ārī, [?], I. v. dep., *hesitate, hang back, be reluctant*: **non quin** (*have no hesitation in, etc.*).

**cūnetus**, -a, -um, [for **coniunctus**?], adj., *all*.

**cuneātīm** [cuneō- (reduced) + **atim**, as if acc. of †**cuneatis**], adv., *in the shape of a wedge*. — Esp. of soldiers, *in* (a peculiar wedge-shaped) *column of attack*.

**cuneus**, -ī, [akin to **conus**], M., *a wedge*.



**cuniculus**, -ī, [Gr. κόνικλος], M., (a cony). — Transferred, a burrow. Hence, a mine (esp. in a military sense).

**cupidē** [abl. of cupidus], adv., eagerly, zealously, earnestly.

**cupiditās**, -tātis, [cupidō + tas], F., desire, eagerness, greed: cupiditate adductus (through over zeal).

**cupidus**, -a, -um, [noun stem akin to cupio + dus], adj., eager, desirous, longing (for), fond of, ambitious (for), with a passion (for).

**cupiō**, -pivī, -pitus, -pere, [partly root verb, partly from †cupi- (cf. cupidus)], 3. (and 4.) v. a. and n., be eager (for), be anxious, desire (stronger than volo). — With dat., wish well to, be zealous for. — Phrase: cupientibus signum dat (gives the signal to his impatient soldiers).

**cūr** (quōr), [perh. for qua re], adv., why (rel. and interr.).

**cūra**, -ae, [for †cavira, akin to caveo], F., care, anxiety, attention: curae alicui esse (be one's care, object of one's attention).

**Curiositāe**, -ārum, reading for the following: —

**Curiositēs**, -tum, [Celtic], M. plur., a people of Armoric Gaul.

**cūrō**, -āvī, -ātus, -āre, [cura], I. v. a. and n., take care. — With gerundive, cause (to be done), have (done).

**currō**, cucurri, cursurus, currere, [? for †curso], 3. v. n., run.

**currus**, -ūs, [√CUR (?) + us, cf. curro], M., a chariot (= essedum).

**cursus**, -sūs, [√CUR (?) + tus, cf. curro], M., a running, running, speed, a run (in concrete sense), a course (space or direction run): cursum adaequare (keep up with); cursu incitato or magno (at full

speed); eodem cursu (with the same impetus, without stopping); in hoc medio cursu (midway of this passage, from Britain to Ireland).

**custōdia**, -ae, [custod + ia], F., custody, guard (state of being guarded). — Plur. (concretely), guards, keepers.

**custōdiō**, -īvī, -ītus, -īre, [custod-, as if custodi-], 4. v. a., keep under guard, guard.

**custōs**, -tōdis, [unc. stem + dis (cf. merces-ēdis, palus-ūdis)], C., a guard, a watchman, a keeper.

## D.

**d.**, see a. d.

**D** [half of Φ, CIO = M], 500.

**D.**, abbrev. for Decimus.

**Dācius**, -a, -um, [?], adj., Dacian (of the Dacians, a people of Thrace, north of the Carpathian Mts., occupying parts of Hungary, Gallicia, Wallachia, etc.). — Plur., the Dacians (the people).

**dannātus**, -a, -um, p.p. of damno. **dannō**, -āvī, -ātus, -āre, [dannō-], I. v. a., (fine), find guilty, condemn.

**damnum**, -ī, [?, √DA + menus (cf. alumnus)], N., (fine), loss.

**Dānubius** (-vius), -ī, [?], M., the Danube, the great river flowing from the mountains of Germany eastward to the Black Sea.

**datus**, -a, -um, p.p. of do.

**dē** [unc. case-form of pron. stem DA (in idem, dum)], prep. with abl., (down, only in comp. as adv.), down from, off from, from, away from. Hence, qua de causa (for which reason); de populo mereor (deserve well or ill of, properly win from); de consilio (by, cf. ex). —

Esp. in partitive sense, *out of, of*: *pauci de nostris*. — Also (cf. Eng. *of*), *about, of* (about), *in regard to, concerning, for*: *de regno desperare*; *nihil de bello timere* (*have no fear of war*); *de potentatu contendere*; *de injuriis satisfacere*. — In expressions of time, *just after, about*: *de tertia vigilia*. — Often with verbs of sense which may take acc.: *sentio de* (*learn, discover*). — Phrases: *de improviso* (*of a sudden*). — In comp., *down, off, away, through* (cf. *debeo, decerto*).

**dēbēō**, -būi, -bitus, -bēre, [*de-habeo*], 2. v. a., (*have off of one's possessions*), *owe, be bound, ought, cannot help*: *judicari debere* (*might well be, etc.*). — Pass., *be due, be owing*.

**dēcēdō**, -cēssi, -cēsūrus, -cēdere, [*de-cedo*], 3. v. n., (*make way off, cf. cedo*), *retire, withdraw, withdraw from, shun*. — Esp. (from life), *die*.

**decem** [?], indecl. adj., *ten*.

**dēceptus**, -a, -um, p.p. of *decipio*.

**dēcernō**, -crēvi, -crētus, -cernere, [*de-cerno*], 3. v. a. and n., (*decide off, so as to clear away*), *decide, determine, decree, order* (as a result of determination).

**dēcertō**, -āvī, -ātus, -āre, [*de-certo*], 1. v. a. and n., (*contend* (so as to close the contest), *decide the issue, try the issue* (of war), *carry on war, fight* (a general engagement): *pugna* (*risk a decisive battle*).

**dēcēssus**, -sūs, [*de-†cessus*, cf. *decedo* and *incessus*], M., *withdrawal, departure*: *aestus* (*ebb, fall*).

**Decetia**, -ae, [Celtic], F., a city of the Hædui, on the Loire.

**dēcidō**, -cidi, no p.p., -cidere, [*de-cado*], 3. v. n., *fall off* (or down), *fall* (from one's horse).

**decimānus**, see *decumanus*.

**decimus**, -a, -um, [†*deci-* (as stem of *decem*) + *mus*], adj., *tenth*. — Masc. as subst., a Roman praenomen (see *Brutus*).

**dēcipiō**, -cēpi, -ceptus, -cipere, [*de-capio*], 3. v. a., (*take off, catch*), *beguile, deceive*.

**dēclārō**, -āvī, -ātus, -āre, [*de-claro*], 1. v. a., (*clear off*), *make plain, declare* (decide and state).

**dēclivis**, -es, [*de-clivis* (or *clivus* weakened)], adj., *sloping down, inclined*. — Plur. as subst., *slopes*.

**dēclivitās**, -tātis, [*declivi + tas*], F., *slope*: *ad declivitatem* (*downward*).

**dēcrētum**, -ī, [prop. N. of *decretus*], N., *a decree, a decision*.

**dēcrētus**, -a, -um, p.p. of *decerno*.

**decumānus**, -a, -um, [*decumō-* (reduced) + *anus*], adj., *belonging to the tenth*: *porta* (*the rear gate, of a camp, where the tenth cohort was posted*).

**decuriō**, -ōnis, [*decuria-* (reduced) + *o*], M., *a commander* (of a decuria of cavalry, a small squadron).

**dēcurrō**, -curri (cucurri), -cursūrus, -currere, [*de-curro*], 3. v. n., *run down, run away, hurry off*.

**decus**, -oris, [unc. root (cf. *decet*) + *us*], N., *honor, glory*.

**dēdecus**, -oris, [*de-decus*], N., *disgrace, dishonor*.

**dēditicius**, -a, -um, [*editō-* (reduced) + *cius*], adj., *surrendered*. — Plur. as subst., *prisoners* (taken by surrender), *subjects, persons surrendered*.

**dēditīō**, -ōnis, [de-datio, cf. **dedo**], F., *surrender*: in **deditionem accipere** (*receive one's surrender*).

**dēditus**, -a, -um, p.p. of **dedo**.

**dēdō**, -didī, -ditus, -dere, [de-do], 3. v. a., *give over, surrender, give up*. — In pass. or with reflex., *surrender one's self, submit*.

**dēducō**, -dūxi, -ductus, dūcere, [de-duco], 3. v. a., *lead down or off, lead away, withdraw, draw off* (**praesidia**), *take away* (of men), *bring away, lead* (from one place to another), *bring* (into a situation). — Fig., *induce, bring, lead*. — Esp. of ships, *launch* (draw down); of women, *marry* (used of the man); of things, *bring, draw, turn*. So, *raise* (a man to fortune). — Also, **rem in periculum** (*cause a perilous situation*); **re in controversiam deducta** (*coming to, etc.*); **deduci milites** (*march out, led by their commander*).

**dēductus**, -a, -um, p.p. of **deduco**.

**dēfatigātīō**, see **defetigatio**.

**dēfatigō**, see **defetigo**.

**dēfectiō**, -ōnis, [de-factio, cf. **deficio**], F., *falling off, defection, falling away, revolt*.

**dēfendō**, -fendī, -fēnsus, -fendere, [de-fendo], 3. v. a., *ward off, defend one's self against*. — Also, with changed relation, *defend, protect*.

**dēfēnsiō**, -ōnis, [de-†fensio, cf. **defendo**], F., *a defence*.

**dēfēnsor**, -ōris, [de-†fensor, cf. **defendo**], M., *a defender*. — Also, *a means of defence*. — Phrase: **speciem defensorum** (*a show of defence*).

**dēferō**, -tulī, -lātus, -ferre, [de-fero], irr. v. a., *carry down, carry away, bring, land* (of ships). — Pass., *be borne down or on, drift* (of

ships), *turn aside*: **delati in scrobes** (*falling*). — Fig., *confer upon, put in one's hands, report, lay before*.

**dēfessus**, -a, -um, p.p. of **defetiscor**.

**dēfetigātīō**, -ōnis, [de-fatigatio], F., *exhaustion*.

**dēfetigātus**, -a, -um, p.p. of **defetigo**.

**dēfetigō**, -āvī, -ātus, -āre, [de-fatigo], 1. v. a., *wear out, exhaust, worry, tire out*.

**dēfetiscor**, -fessus, -fetiscī, [de-fatiscor], 3. v. dep., *crack open*. — Fig., *become exhausted*. — **dēfessus**, -a, -um, p.p. as adj., *exhausted*: **defesso** (*an exhausted man*).

**dēficiō**, -fēcī, -fectus, -ficere, [de-facio], 3. v. a. and n., *fail, fall away, revolt, fall off, abandon* (with **ab**): **animō** (*despond*).

**dēfigō**, -fixī, -fixus, -figere, [de-figo], 3. v. a., *fix* (in or down), *plant, set, fasten, drive down*.

**dēfiniō**, -ivī, -itus, -ire, [de-finio], 4. v. a., *set limits to, fix, appoint*.

**dēfixus**, -a, -um, p.p. of **defigo**.

**dēfluō**, -flūxī, -fluxūrus, -fluere, [de-fluo], 3. v. n., *flow down, flow apart, divide* (of a river).

**dēfore**, see **desum**.

**dēformis**, -e, [de-forma, weakened and decl. as adj.], adj., *uncomely, unshapely, ugly, bad-looking*.

**dēfugiō**, -fūgī, -fugitūrus, -fugere, [de-fugio], 3. v. a. and n., *fly from, avoid, fly*.

**dēiciō** (**dējic-**), -jēcī, -jectus, -icere, [de-jacio], 3. v. a., *cast down, throw down, drive off, drive out, dislodge, kill* (pass. *fall*), *overthrow, throw on shore* (of ships), *deprive, reduce*.

**deinceps** [dein- + ceps, cf. **princeps**], adv., *in succession*.

**deinde** (**dein**) [**de-inde**], adv., *then, next.*

**dējectus**, -tūs, [**de-jactus**], M., *a declivity, a slope.*

**dējiciō**, see **deicio**.

**dēlectō**, -āvi, -ātus, -āre, [**de-lecto**], 1. v. a., *delight*. — Pass., *take delight, delight.*

**dēlēctus**, -tūs, [**de-lectus**, cf. **deligo**], M., *a levy, a conscription.*

**dēlēctus**, -a, -um, p.p. of **deligo**.

**dēlēō**, -lēvi, -lētus, -lēre, [**de-pleo** (akin to **lino**)], 2. v. a., (*smear out*), *blot out, wipe out* (of a disgrace). — Fig., *annihilate, destroy.*

**dēlētus**, -a, -um, p.p. of **deleo**.

**dēliberō**, -āvi, -ātus, -āre, [**de-tribero**, perh. akin to **libra**], 1. v. a. and n., *discuss, consult, deliberate*: *re deliberata* (*after discussing the matter*).

**dēlibrō**, -āvi, -ātus, -āre, [**de-librō** (adj. **de-liber**)], 1. v. a., *peel, strip* (of bark).

**dēlictum**, -ī, [N. p.p. of **delinquo**], N., *thing left undone, failure, offence.*

**dēligātus**, -a, -um, p.p. of **deligo** (-āre).

**dēligō**, -lēgi, -lēctus, -ligere, [**de-lego**], 3. v. a., *choose out, select*. —

**dēlectus**, -a, -um, p.p. as adj., *chosen, picked.*

**dēligō**, -āvi, -ātus, -āre, [**de-ligo**], 1. v. a., *tie down, moor, tie.*

**dēlitescō**, -lituī, no p.p., -litēscere, [**de-latesco**], 3. v. n., *hide away, hide, skulk.*

**dēmentia**, -ac, [**dement** + **ia**], F., *madness, folly.*

**dēmessus**, -a, -um, p.p. of **demeto**.

**dēmetō**, -messuī, -messus, -metere, [**de-meto**], 3. v. a., *reap, cut down.*

**dēmigrō**, -āvi, -ātūrus, -āre, [**de-**

**migro**], 1. v. n., *move away* (change residence), *move one's effects.*

**dēminuō**, -ui, -ūtus, -uere, [**de-minuo**], 3. v. a. and n., *diminish, curtail, lessen, detract*: *de voluptate quiequam* (*make any diminution of*); *de sua benevolentia* (*lessen his good-will*).

**dēminūtus**, -a, -um, p.p. of **deminuo**.

**dēmittō**, -misi, -missus, -mittere, [**de-mitto**], 3. v. a., *let go down* (cf. **mitto**), *let down, stick down* (at the bottom of a ditch). — In pass. or with reflex., *let one's self down, descend, set one's self down*. — Fig., *despond* (*se animo*), *be discouraged*. — **dēmissus**, -a, -um, p.p. as adj., *low-hanging* (*bowed, of the head*).

**dēmō**, dēmpsi, dēemptus, dēmere, [**de-emo, take**], 3. v. a., *take down, take off.*

**dēmōnstrātus**, -a, -um, p.p. of **demonstro**.

**dēmōnstrō**, -āvi, -ātus, -āre, [**de-monstro**], 1. v. a., *point out, show, represent, mention, state, speak of.*

**dēmoror**, -ātus, -ārī, [**de-moror**], 1. v. dep., *delay, retard* (interfere with).

**dēmum** [acc. of †**dēmus** (superl. of **de**), *nethermost, last*], adv., *at last, at length* (not before).

**dēnegō**, -āvi, -ātus, -āre, [**de-nego**], 1. v. a. and n., *deny, refuse, say not.*

**dēni**, -ae, -a, [for **decni**, **decem** reduced + **nus**], adj. plur., *ten each, ten* (on each side), *ten* (in sets of ten).

**dēnique** [†**denō** (**de** + **nus**, cf. **demum**) **que**], adv., *at last*: *multo denique die* (*not till late, etc.*). — Of order, *finally*. — Of preference, *at any rate* (if no better, etc.).

**dēns**, dentis, [?, cf. *tooth* (for †*tooth*)], M., a *tooth*.

**dēnsus**, -a, -um, [?], adj., *thick, crowded, dense*.

**dēnūntiō**, -āvi, -ātus, -āre, [de-nuntio], I. v. a., *announce* (with notion of threat), *declare, warn*.

**dēpellō**, -pulī, -pulsus, -pellere, [de-pello], 3. v. a., *drive off, drive (away), dislodge, avert*.

**dēperdō**, -didī, -ditus, -dere, [de-perdo], 3. v. a., *lose, be deprived of: tantum opinionis (forfeit)*.

**dēpereō**, -periī, no p.p., -perīre, [de-pereō], irr. v. n., *be lost*.

**dēpōnō**, -posuī, -positus, -pōnere, [de-pono], 3. v. a., *lay down, lay aside, deposit*. — Fig., *lose, abandon (hope), blot out (memory), resign*.

**dēpopulātus**, -a, -um, p.p. of *depopulo*.

**dēpopulo**, -ātus, -ārī, [de-populo], I. v. dep., *ravage, lay waste*.

**dēportō**, -āvi, -ātus, -āre, [de-porto], I. v. a., *carry off, carry away, remove*.

**dēposcō**, -poposci, no p.p., -poscere, [de-posco], 3. v. a., *demand, call for, claim*.

**dēpositus**, -a, -um, pp. of *depono*.

**dēprecātor**, -ōris, [de-precator, cf. *deprecor*], M., a *mediator* (to beg off something for somebody): *eo deprecatore (by his mediation)*.

**dēprecor**, -ātus, -ārī, [de-precor], I. v. 'dep., *pray to avert something, pray* (with accessory notion of relief), *beg, beg off, pray for pardon, pray to be spared, resort to prayers*.

**dēprehendō**, -hendī, -hēnsus, -hendere, [de-prehendo], 3. v. a., *capture, catch, seize, take possession of*. — As in Eng., *catch (come upon), surprise*.

**dēprehēnsus**, -a, -um, p.p. of *deprehendo*.

**dēprimō**, -pressī, -pressus, -primere, [de-premo], 3. v. a., *press down, sink*.

**dēpulsus**, -a, -um, p.p. of *de-pello*.

**dērivātus**, -a, -um, p.p. of *de-rivo*.

**dērivō**, -āvī, -ātus, -āre, [perh. immediately fr. *de-rivus*, prob. through adj.-stem], I. v. a., *draw off (water), divert*.

**dērogō**, -āvī, -ātus, -āre, [de-rogo, in its political sense], I. v. a., *take away, withdraw*.

**dēscendō**, -scendī, -scēnsūrus, -scendere, [de-scando], 3. v. n., *climb down, descend*. — Fig., *resort to, have recourse to, adopt* (with ad).

**dēsecō**, -secuī, -sectus, -secāre, [de-seco], I. v. a., *cut off*.

**dēserō**, -seruī, -sertus, -serere, [de-sero], 3. v. a., *disunite*. — Esp., *abandon, forsake, give up, leave in the lurch*. — **dēsertus**, -a, -um, p.p. as adj., *deserted, solitary*.

**dēsertor**, -ōris, [de-†sertor, cf. *desero*], M., a *deserter*.

**dēsertus**, -a, -um, p.p. of *desero*.

**dēsiderātus**, -a, -um, p.p. of *desidero*.

**dēsiderō**, -āvī, -ātus, -āre, [?, cf. *considero*], I. v. a., *feel the want of, desire, miss, need, desire (want to see), lose* (of soldiers). — Pass., *be missing (lost)*: *perpauci desiderati quin cuncti*, etc. (*all with very few exceptions*).

**dēsīdia**, -ae, [desid- (stem of *deses*, de-√SED as stem)], F., *idleness, sloth*.

**dēsīgnātus**, -a, -um, p.p. of *desīgno*.

**dēsīgnō**, -āvi, -ātus, -āre, [de-signō], 1. v. a., *mark out, indicate, mean*.

**dēsiliō**, -siluī, -sultus, -silire, [de-salio], 4. v. n., *leap down, leap (down), jump overboard*.

**dēsistō**, -stiti, -stitūrus, -sistere, [de-sisto], 3. v. n., *stand off, cease, stop, desist from, abandon: fuga (cease flying)*.

**dēspectus**, -a, -um, p.p. of **despicio**.

**dēspectus**, -tūs, [de-†spectus, cf. **despicio**], M., *a view down, view (from a height): oppidum haberet despectum (a precipice)*.

**dēspērātiō**, -ōnis, [de-†speratio, cf. **despero**], F., *despair, desperation*.

**dēspērātus**, -a, -um, p.p. of **despero**.

**dēspērō**, -āvi, -ātus, -āre, [despero], 1. v. n. (but see below), *cease to hope, despair*. — **dēspērātus**, -a, -um, as passive, *despaired of*. — Also as adj., (*hopeless?*, perh. orig. *despaired of*), hence *desperate*.

**dēspiciō**, -spēxi, -spectus, -spicere, [de-specio], 3. v. a. and n., *look down, look down upon*. — Fig. (cf. Eng. equivalent), *look down upon, despise*.

**dēspoliō**, -āvi, -ātus, -āre, [despolio], 1. v. a., *strip off*. — With change of relation, *strip* (also fig., as in Eng.).

**dēstinātus**, -a, -um, p.p. of **destino**.

**dēstinō**, -āvi, -ātus, -āre, [perh. **dēstinā-** (*a prop.*, de-√STA-nus)], 1. v. a., *fasten, make fast, make firm, get fast hold of, catch firmly*. Hence, fig., *fix upon, appoint, choose, destine*.

**dēstituō**, -tuī, -tūtus, -tuere, [de-stātuo], 3. v. a., *set apart (from one's self), abandon, desert*.

**dēstitūtus**, -a, -um, p.p. of **destituo**.

**dēstrictus**, -a, -um, p.p. of **destringo**.

**dēstringō**, -strinxī, -strictus, -stringere, [de-stringo], 3. v. a., *strip off*. — Also (cf. **despolio**), *strip, draw* (of swords, stripping them of their scabbards).

**dēsum**, -fuī, -futūrus, -esse, [desum], irr. v. n., (*be away*), *be wanting, be lacking, fail*. — Esp., *fail to do one's duty by*, etc. — Often, *lack* (changing relation of subj. and following dat.), *be without, not have*.

**dēsuper** [de super], adv., *from above*.

**dēterior**, -us, [compar. of †deter (de + terus, cf. **interior**)], adj., (*farther down*), *inferior, worse: deteriora vectigalia facere (im-pair)*.

**dēterreō**, -terruī, -territus, -terrere, [de-terreo], 2. v. a., *frighten off, deter, prevent* (esp. by threats, but also generally).

**dētestātus**, -a, -um, p.p. of **detestor**.

**dētestor**, -ātus, -ārī, [de-testor], 1. v. a., (*call the gods to witness to prevent something*), *entreat* (from a thing). — Also, *curse*.

**dētimeō**, -tinuī, -tentus, -tinere, [de-teneo], 2. v. a., *hold off, detain, delay*.

**dētractō** (-tracto), -āvi, -ātus, -āre, [de-tracto], 1. v. a., (*hold off from one's self*), *avoid, shun*.

**dētractus**, -a, -um, p.p. of **detraho**.

**dētrahō**, -trāxi, -tractus, -trahere, [de-traho], 3. v. a., *drag off, snatch (away)*. — With less violence, *take away, take off, withdraw* (with no violence at all).

**dētrectō**, see **detracto**.

**dētrimentōsus**, -a, -um, [**detrimentō** (reduced) + **osus**], adj., *detrimental*.

**dētrimentum**, -ī, [**de-†trimentum** (**tri-** in **teŕo** + **mentum**), cf. **detero**], N., (*a rubbing off*), *loss, injury*. — Esp., *defeat, disaster*.

**dētrūdō**, -trūsī, -trūsus, -trūdere, [**de-trudo**], 3. v. a., *shove off, strip off, thrust off*: *scutis tegumenta* (remove the coverings in which the metal shields of the Romans were kept).

**dēturbātus**, -a, -um, p.p. of **dēturbo**.

**dēturbō**, -āvī, -ātus, -āre, [**dēturbo**], 1. v. a., *drive off* (in confusion).

**dēūrō**, -ūssi, -ūstum, -ūrere, [**dēuro**], 3. v. a., *burn off*.

**deus**, -ī, [akin to **divus**, **Jovis**, **dies**], M., *a god*.

**deūstus**, -a, -um, p.p. of **deuro**.

**dēvehō**, -vēxī, -vectus, -vehere, [**de-veho**], 3. v. a., *carry away, bring* (away, e.g. on horseback).

**dēveniō**, -vēnī, -ventūrus, -venīre, [**de-venio**], 4. v. n., *come away, land* (come down from the sea), *come* (from one place to another).

**dēvexus**, -a, -um, [prop. a p.p. of **deveho**], adj., *sloping*. — Neut. plur. as subst., *slopes, hillsides*.

**dēvictus**, -a, -um, p.p. of **dēvinco**.

**dēvineō**, -vīcī, -victus, -vincere, [**de-vinco**], 3. v. a., *conquer* (so as to prostrate), *subdue* (entirely).

**dēvocō**, -āvī, -ātus, -āre, [**de-voco**], 1. v. a., *call down* (or away). — Esp., fig., *invite, bring*: *fortunas in dubium*.

**dēvōtus**, -a, -um, p.p. of **dēvoveo**.

**dēvoveō**, -vōvī, -vōtus, -vovēre, [**de-voveo**], 2. v. a., *vow* (away). — Less exactly, *devote*. — **dēvōtus**, -a, -um, p.p. as subst., *a devoted follower* (sworn to die with his companion).

**dexter**, -era, -erum, [unc. stem (perh. akin to **digitus**?) + **terus**], adj., *right* (in the right hand). — **dextra**, F., (sc. **manus**), *the right hand* (esp. used as a pledge of faith, as with us).

**Diablīntres** (-tes), -um, [Celtic], M. plur., a Gallic tribe, a branch of the Aulerici.

**dicīō** (less correctly **dit-**), -ōnis, [stem akin to **dico** + **o**, cf. **legio**], F., (*command*, cf. Eng. “say”), *dominion, sway*.

**dicō**, -āvī, -ātus, -āre, [†**dicō-** (cf. **causi-dicus**)], 1. v. a., *adjudge, assign* (in some legal manner). — Less exactly (esp. with reflex.), *assign, make over*: *se in clientelam* (*bind one's self, attach one's self*); *se in servitūtem* (*surrender*).

**dicō**, **dixī**, **dictus**, **dicere**, [√**DIC**, in **dīco** and **-dicus**], 3. v. a. and n., (*point out?*, cf. Gr. **δείκνυμι**), *say, speak, name*. — Esp., with authority, *name, appoint, fix*: **jus** (*administer*, cf. **dīco**); **sententiam** (*give*). — Special uses: **dicunt** (*they say*); **causam dicere** (*plead one's cause, hence be tried, be brought to trial*). — See also **dictum**.

**dictiō**, -ōnis, [**dic** (as root of **dico**) + **tiō**], F., *a speaking, a pleading* (cf. **dico**): **causae** (*pleading one's cause, trial*).

**dietum**, -ī, [N. p.p. of **dico**], N., *a thing said, a statement, a remark, a command*: **dicto audiens esse alicui** (*be obedient, obey*).

**didūcō**, -dūxī, -ductus, -ducere,

[dis-duco], 3. v. a., *draw apart, lead apart, separate, divide.*

**dies**, -ei, [prob. for **dives**, √DVU + AS], M. (rarely F. in some uses), *a day* (in all Eng. senses). — Also, *time*: **in dies** (*from day to day*, with idea of increase or diminution): **diem ex die ducere** (*put off a thing day after day*); **dies longior** (*a later time*).

**differō**, distuli, dilātus, differre, [dis-fero], irr. v. a. and n., *bear apart, spread*. — Also, *postpone, defer, differ*.

**difficilis**, -e, [dis-facilis], adj., *not easy, difficult*.

**difficultās**, -tātis, [difficili- (weakened) + tās], F., *difficulty*: **magna difficultate afficiebatur** (*was much troubled*); **rei frumentariae** (*difficulty of supplying grain*).

**difficulus** [difficili- (weakened) + ter], adv., *with difficulty*.

**diffidō**, -fisis sum, -fidere, [dis-fido], 3. v. n., *distrust, not have confidence*.

**diffundō**, -fūdī, -fūsus, -fundere, [dis-fundo], 3. v. a., *spread out*.

**digitus**, -ī, [?], M., *a finger*: **pollex** (*the thumb*). — As in Eng., *a finger's breadth, a finger* (as a measure).

**dignitās**, -tātis, [dignō + tas], F., *worthiness, worth, dignity, prestige, position (superior)*; **tribuere** (*have respect for*).

**dignus**, -a, -um, [?, perh. root of dico + nus], adj., *worthy*.

**dijūdicō**, -āvī, -ātus, -āre, [dis-iudico], 1. v. a. and n., *decide* (between two).

**dilēctus**, -a, -um, p.p. of **diligō**.

**diligēns**, -entis, [pres. p. of diligō], adj., *careful, diligent*.

**diligenter** [diligent + ter], adv., *carefully, with care, with exactness, exactly, with pains*: **conservavit** (*took pains to save*).

**diligentia**, -ae, [diligent + ia], F., *care, pains, painstaking, diligence*: **remittere** (*cease to take pains, take less care*).

**diligō**, -lēxi, -lēctus, -ligere, [dis-lego], 3. v. a., (*choose out*), *love, be fond of*. — See also **diligens**.

**dimēsus**, -a, -um, p.p. of **di-metior**.

**dimētior**, -mēsus, -mētiri, [dis-metior], 4. v. dep., *measure* (in parts), *measure out* (esp. of camp). — **dimēsus**, -a, -um, p.p. in pass. sense, *measured, proportioned*.

**dimicō**, -āvī, -āturus, -āre, [dis-mico], 1. v. n., (*brandish swords to decide a contest?*), *fight* (a decisive battle), *risk an engagement*.

**dimidius**, -a, -um, [dis-medius], adj., (*divided in the middle*), *half*. — Neut. as subst., *the half*.

**dimittō**, -misi, -missus, -mittere, [dis-mitto], 3. v. a., *let go away, let slip, let pass, let go, give up, relinquish, abandon*: **oppugnationem** (*raise*); **victoriam** (*let go, on purpose*). — Also, *send in different directions, send about, despatch, detail, disband, dismiss*.

**directē** [abl. of directus], adv., *straight*: **ad perpendicularum** (*perpendicularly*).

**directus**, -a, -um, p.p. of **dirigo**.

**direptus**, -a, -um, p.p. of **diripio**.

**dirigō**, -rēxi, -rectus, -rigere, [dis-rego], 3. v. a., *straighten out, direct*: **aciem** (*form*); **opera** (*set in order, arrange*). — **directus**, -a, -um, p.p. as adj., *straight*.



**dirimō**, -ēmī, -emptus, -emere, [dis-emo, take], 3. v. a., *take apart, break up* (a conference).

**diripiō**, -ripui, -reptus, -ripere, [dis-rapio], 3. v. a., *seize* (in different directions), *plunder, pillage*.

**dis**, **dī** (**dir**-), [akin to **duo**?], inseparable prep. (adv.), in comp., *asunder, in different directions*. Cf. **discedo**, **discerno**, **dirimo**, **diffundo**.

**Dis**, Ditis, [akin to **dives**, as the earth is the source of riches], M., *Pluto* (the god of the under world, and so of death).

**discēdō**, -cēssi, -cēssurus, -cēdere, [dis-cedo], 3. v. n., *withdraw, depart, retire, leave* (with **ab**), *go away*: *locus unde discesserant* (the place which they had left); *ab officio* (fail in one's duty); *spes hostibus* (forsake, fail); *ab signis* (leave the ranks).

**disceptātor**, -tōris, [disceptā- (stem of **discepto**) + **tor**], M., *a judge, an arbiter*.

**discernō**, -crēvi, -crētus, -cernere, [dis-cerno], 3. v. a., *separate, distinguish*.

**discēssus**, -sūs, [dis-cessus, cf. **discedo**], M., *a departure, a withdrawal*.

**disciplīna**, -ae, [discipulō- (reduced) + **ina**, cf. **rapina**], F., (*pillage* ?), *discipline, instruction, a system* (of doctrine, etc.), *a course of instruction*.

**discipulus**, -ī, [?, akin to **disco**], M., *a pupil*.

**disclūdō**, -clūsi, -clūsus, -clūdere, [dis-claudio], 3. v. a., *shut apart, keep apart, separate, divide*.

**discō**, didici, discitūrus, discere, [for **†disco** ( $\sqrt{\text{DIC}} + \text{sco}$ )], 3. v. a. and n., *learn*: *discendi causa* (for instruction).

**discrimen**, -inis, [dis-crimen, cf. **discerno**], N., *a separation, a decision*. Hence, *a moment of decision, a crisis, critical condition, danger*.

**discussus**, -a, -um, p.p. of **discutio**.

**discutiō**, -cussi, -cussus, -cutere, [dis-quatō], 3. v. a., *strike* (or *shake*) *apart, beat away, drive away, dislodge, shatter*.

**disiciō**, -jēcī, -jectus, -icere, [dis-iacio], 3. v. a., *hurl apart, break up* (a phalanx), *tear off* (yards). — **disiectus**, -a, -um, p.p. as adj., *scattered, broken, in disorder*: *pabulatio* (in widely scattered places).

**disiectus**, -a, -um, p.p. of **disicio**.

**disjiciō**, see **disicio**.

**dispar**, -paris, [dis-par], adj., *unequal, inferior, ill-matched*.

**disparō**, -āvī, -ātus, -āre, [dis-paro], I. v. a., *scatter* (cf. **disiungo**).

**dispergō**, -spersi, -spersus, -speregere, [dis-spargo], 3. v. a., *scatter, disperse*.

**dispersus**, -a, -um, p.p. of **dispergo**.

**dispōnō**, -posui, -positus, -pōnere, [dis-pono], 3. v. a., *place about* (in various places), *station* (variously), *array* (at several posts).

**dispositus**, -a, -um, p.p. of **dispono**.

**disputātiō**, -ōnis, [dis-putatio, cf. **disputo**], F., *discussion*.

**disputō**, -āvī, -ātus, -āre, [dis-puto], I. v. n. and a., *discuss* (cf. **puto**).

**dissēnsiō**, -ōnis, [dis-†sensio (cf. **dissentio**)], F., *difference of opinion, disagreement, dissension*.

**dissentiō**, -sēnsī, -sēnsurus, -sentire, [dis-sentio], I. v. n., *differ in*

*opinion* (cf. *sentio*), *be at variance, disagree* (*ab, with*).

**dissimulō**, -āvi, -ātus, -āre, [*dis-simulo*], 1. v. a. and n., (*pretend something is not*), *conceal* (what is), *dissemble*.

**dissipātus**, -a, -um, p.p. of *dis-sipo*.

**dissipō**, -āvi, -ātus, -āre, [*dis-†supo, throw*], 1. v. a., *scatter, disperse*: *dissipati* (*straggling troops*).

**dissuādēō**, -suāsī, -suāsūs, -suādēre, [*dis-suadeo*], 2. v. a., *advise to the contrary, oppose* (in argument), *dissuade*.

**distineō**, -tinuī, -tentus, -tinēre, [*dis-teneo*], 2. v. a., *keep apart, hold asunder, keep from uniting, cut off* (in military sense), *isolate*.

**distō**, -stāre, [*dis-sto*], 1. v. n., *stand apart*: *quantum junctura distabat* (*as far as the distance between, etc.*); *quantum summa labra distabant* (*the width [of the ditch] at the top*).

**distrahō**, -trāxī, -trāctus, -trahere, [*dis-traho*], 3. v. a., *drag asunder, separate*. Hence, *distract*.

**distribuō**, -buī, -būtus, -buere, [*dis-tribuo*], 3. v. a., *assign* (to several), *distribute, divide*.

**ditio**, less correct for **dicio**.

**ditissimus**, -a, -um, superl. of *dives*.

**diū** [prob. acc. of stem akin to *dies*], adv., *for a time, a long time, for some time, long*: *tam diu* (*so long*); *quam diu* (*how long, as long*); *diutius* (*any longer*).

**diurnus**, -a, -um, [*†dius*, akin to *diu* and *dies*, + *nus*], adj., *of the day, daily* (as opposed to *nightly*): *nocturnis diurnisque itineribus* (*by night and day*).

**diūtinus**, -a, -um, [*diu + tinus*,

cf. *crastinus*], adj., (*long in time*), *long continued*.

**diūturnitās**, -tātis, [*diurno + tas*], F., *length of time, long continuance, length* (in time).

**diūturnus**, -a, -um, [*diu + turnus*, cf. *hesternus*], adj., *long continued, long* (in time).

**diversus**, -a, -um, p.p. of *diverto*.

**divertō**, -vertī, -versus, -vertere, [*dis-vertō*], 3. v. a. and n., *turn aside* (or *apart*), *separate*. — **diversus**, -a, -um, p.p. as adj., *separate, distant, diverse, different*.

**dives**, -itis, [?], adj., *rich*.

**Divicō**, -ōnis, [Celtic], M., a leader of the Helvetii.

**dividō**, -visī, -visus, -videre, [*dis-†vido, √VIDH(?)*, cf. *viduus*], 3. v. a., *divide, separate*. — **divisus**, -a, -um, p.p. as adj., *divided*: *Gallia divisa est*. — Also, *spread out*.

**divinus**, -a, -um, [*divō-* (as if *divi*) + *nus*], adj., *of the gods, divine*: *res divinae* (*religion, matters of religion*).

**Divitiacus**, -ī, [Celtic], M.: 1. A leader of the Hædui, brother of Dumnorix. — 2. A leader of the Suesiones.

**divulgō** (-*volgo*), -āvi, -ātus, -āre, [*dis-vulgo*], 1. v. a., *spread abroad*.

1. **dō**, *dedi*, *datus*, *dare*, [*√DA*, *give*, cf. 2. **do**], 1. v. a., *give, afford, offer, allow, concede, assign, grant*: *responsum* (*answer, reply*); *sibi minus dubitationis dari* (*that he had less hesitation*); *filiam matrimonium* (*marry*); *se vento* (*run before the wind*); *manus* (*submit, yield, from holding out the hands to be bound*); *hostes in fugam* (*put to flight*); *operam* (*take pains, exert one's self, see to it that, etc.*); *nego-*

tium uti (*employ one to, etc., engage one to, etc.*); *suspicionem* (*afford, make a show, but also have an appearance*); *arbitros* (*assign referees, a judicial function*).

2. **do** [ $\sqrt{\text{DHA}}$ , *place*], confounded with 1. **do**, but appearing in comp., *place, put, as abdō, condō*.

**doceō**, docuī, doctus, docēre, [unc. formation akin to **dico** and **disco**], 2. v. a., *teach, show, inform, represent, state* (in the text of the book).

**documentum**, -ī, [**docu-**(?) (as stem of **doceo**) + **mentum**], N., *a means of teaching, a proof, a warning, an example*.

**doleō**, doluī, dolitūrus, dolēre, [perh. **dolō-**(stem of **dolus**)], 2. v. n., *feel pain, suffer*. — Esp. mentally, *be pained, grieve*.

**dolor**, -ōris, [**dol-** (as root of **doleo**) + **or**], M., *pain* (physical or mental), *distress, indignation, chagrin, vexation: magno dolore ferre* (*be very indignant, feel much chagrin*); *magno esse dolori* (*to be a great annoyance or sorrow*).

**dolus**, -ī, [perh. akin to **doleo**, originally *stroke?*], M., *an artifice, deceit, tricks, a stratagem*.

**domesticus**, -a, -um, [**domō-** (as if **domes-**, cf. **modestus**) + **ticus**], adj., (*of the house*), (*of one's home, one's own, at home*): *bellum* (*domestic, internal, intestine*).

**domicilium**, -ī, [perh. **domō** + **teilium** (fr. root of **colo**)], N., *an abode, a house, a dwelling-place, a house* (as a permanent home).

**dominor**, -ātus, -ārī, [**dominō-**], 1. v. dep., *rule, be master*.

**dominus**, -ī, [**domō-** (*ruling*, cf. Gr.  $\delta\alpha\mu\omicron\varsigma$ ) + **nus**], M., *a master, an owner*.

**Domitius**, -ī, [**domitō-**(reduced)

+ **ius**], M., a Roman gentile name. — Esp., *Lucius Domitius Ahenobarbus*, consul in B.C. 54.

**domus**, -ī (-ūs), [ $\sqrt{\text{DOM}}$  (*build?*) + **us** (-os and -us)], F., *a house, a home*: **domī** (*at home*); **domum** (*home, to one's home*); **domo** (*from home*); **domo exire** (*go away, emigrate*).

**dōnātus**, -a, -um, p.p. of **dono**.

**Donnotaurus**, -ī, [Celtic], M., a Gallic name. — Esp., *Gaius Valerius Donnotaurus*, a chief of the Helvetii, brother of C. Valerius Procillus. The first two names of these persons are Roman, taken from the name of their patron.

**dōnō**, -āvī, -ātus, -āre, [**donō-**], 1. v. a., *present, give* (as a gift). — Also, *honor with a gift, present* (one with a thing); *civitate aliquem donare* (*give one the rights of citizenship*).

**dōnum**, -ī, [ $\sqrt{\text{DA}}$  + **nus**], N., *a gift*.

**dorsum** (-us), -ī, [?], N. (and M.), *the back*. — Less exactly, *a summit* (a long ridge).

**dorsus**, -ī, see **dorsum**.

**dōs**, dōtis, [ $\sqrt{\text{DA}}$  + **tis** (reduced)], F., (*a gift*). — Esp., *a marriage gift, a dowry, a portion* (given at marriage).

**Druides**, -um, [Celtic], M., *the Druids*, the priests of the Gallic religion.

**Dūbis**, -is, [Celtic], M., *the Doubs* (a river of Gaul, flowing from the Jura into the Saône).

**dubitātio**, -ōnis, [**dubitā-** (stem of **dubito**) + **tio**], F., *doubt, hesitation*: *alicui minus dubitationis dari* (*to feel less doubt or hesitation*).

**dubitō**, -āvī, -ātūrus, -āre, [**du-** + **bitō-** (partic. of lost verb **dubo?**, cf.

**dubius**], I. v. n., *doubt, have doubt, feel doubtful*. — Also (absolutely, or with inf., rarely **quin**), *hesitate, feel hesitation, vacillate*.

**dubius**, -a, -um, [duo + bius, cf. **superbus** and **dubito**], adj., *doubtful*: **est dubium** (*there is doubt, it is doubtful*).

**ducenti**, -ae, -a, [duo-centi (plur. of **centum**)], adj., *two hundred*.

**dūcō**, dūxi, ductus, dūcere, [√DUC (in **dux**)], 3. v. a., *lead, draw, bring* (of living things). — Esp. of a general, *lead, march*. — With (or without) **in matrimonium**, *marry* (of the man). — Fig., *prolong, drag out*. — As mercantile word, and so fig., *reckon, consider*: **fossam** (*run, make*).

**ductus**, -tūs, [√DUC + tus], M., *lead, command*.

**dum** [pron. √DA, prob. acc., cf. **tum**], conj., *at that time*. — Also, *while, so long as*. Hence, *till, until*.

**Dumnorix**, -igis, [Celtic], M., a leader of the Hædui, brother of Divitiacus.

**duō**, -ae, -ō, [dual, of stem †dvō-, cf. **bis**], adj., *two*.

**duodecim** [duo-decem], indecl. adj., *twelve*.

**duodecimus**, -a, -um, [duo-decim], adj., *twelfth*.

**duodēni**, -ae, -a, [duo deni], adj., *twelve* (in a set).

**duodēviginti** [duo de viginti], indecl. adj., *eighteen*.

**duplex**, -plicis, [duo-†plex, cf. **simplex**], adj., *two-fold, double*: **acies** (*in two divisions*, arranged for successive attacks in the same direction, or for the same tactical purpose).

**duplicō**, -āvī, -ātus, -āre, [duplic-], I. v. a., *double, increase two-fold*.

**dūritia**, -ae, [durō + tia], F., *hardness, hardship*.

**dūrō**, -āvī, -ātus, -āre, [durō-], I. v. a., *harden, toughen, make hardy*.

**Durocortorum**, -ī, [Celtic], N., the chief city of the Remi, now *Rheims*.

**dūrus**, -a, -um, [?], adj., *hard*. — Fig., *hard, severe, difficult*: **si quid erat durius** (*any severe contest*): **si nil esset durius** (*if no accident happened*).

**Dūrus**, -ī, [durus], M., a Roman family name. — Esp., *Quintus Laberius Durus*, a military tribune in Cæsar's army, killed in Britain.

**dux**, ducis, [√DUC as stem], C., *a leader, a guide, a commander*.

## E.

**ē**, see **ex**.

**eā** [instr. or abl. of **is**], adv., *this way, that way, thus*.

**Eburōnes**, -um, [Celtic], M. plur., a Belgian tribe, dependents of the Treviri.

**Ebuovices**, -um, [Celtic], M. plur., a Gallic tribe, a branch of the Auleri living in the region of modern *Perche*.

**ecferō**, see **effero**.

**ēdicō**, -dixī, -dictus, -dicere, [ex-dico], 3. v. a., *issue an edict, proclaim, order*.

**ēdiscō**, -didicī, no p.p., -discere, [ex-disco], 3. v. a., *learn off, learn by heart, commit to memory*.

**ēditus**, -a, -um, p.p. of **edo**.

**ēdō**, -didī, -ditus, -dere, [ex-do], 3. v. a., *put forth, give forth*: **exempla cruciatusque** (*make an example by inflicting severe torture*). — **ēditus**, -a, -um, p.p. as adj., *elevated, raised, high*.

**ēdoceō**, -docuī, -doctus, -docēre, [ex-doceo], 2. v. a., *show forth, explain, inform.*

**ēducō**, -dūxī, -ductus, -dūcere, [ex-duco], 3. v. a., *lead out, lead forth, draw (a sword), bring out (baggage-train).*

**ēductus**, -a, -um, p.p. of **educō**.

**effarciō**, -farsi, -fertus, -farcire, [ex-farcio], 4. v. a., *stuff out, fill in (solid).*

**effeminō**, -āvi, -ātus, -āre, [ex-†femino, or perhaps †effeminō- (or -i), in either case from **femina**], 1. v. a., *make into a woman.* — Less exactly, (*make like a woman*), *enervate, weaken*: **animos** (*enfeeble, debauch*).

**efferrō**, extulī, clātus, efferre, [ex-fero], irr. v. a., *carry out, bring out, carry away.* — Less exactly and fig., *spread abroad, make known, publish abroad, puff up, elate* (cf. Eng. "carried away."). — Also (cf. **edo**), *raise up*.

**efficiō**, -fēcī, -fectus, -ficere, [ex-facio], 3. v. a., *make out, make, enable, accomplish, cause, produce, cause to be, make into, make out (furnish): ut praeberent (make them afford); ut sint laboris (make capable of); ut posset (make possible); classem (get together).*

**effodiō**, -fōdī, -fossus, -fodere, [ex-fodio], 3. v. a., *dig out, gouge out.*

**effossus**, -a, -um, p.p. of **effodio**.

**effugiō**, -fūgī, -fugitūrus, -fugere, [ex-fugio], 3. v. a., *escape, flee (absolutely), fly from.*

**egēns**, pres. p. of **egeo**.

**egeō**, eguī, no p.p., egēre, [†egō- (cf. **indigus**)], 2. v. n., *want, need, be in want.* — **egēns**, -entis, pres. p. as adj., *needy, destitute.*

**egestās**, -tātis, [unc. stem (perh.

egent-) + **tas**], f., *poverty, destitution.*

**egō**, meī, [cf. Eng. *I*], pron., *I (me, etc.).* — Plur., **nos**, *we, us, etc.*

**ēgredior**, -gressus, -gredi, [ex-gradior], 3. v. dep., *march out, go out, move beyond: fines (pass beyond); navi (land, disembark); unde erant egressi (the place they had left); ex oppido (evacuate).*

**ēgregiē** [abl. of **cgregius**], adv., *remarkably, finely, extremely well.*

**ēgregius**, -a, -um, [e grege (*out of the herd*) + **ius**], adj., *out of the common, remarkable, superior, excellent, uncommon, special.*

**ēgressus**, -a, -um, p.p. of **egredior**.

**ēgressus**, -sūs, [e-gressus, cf. **ingressus** and **egredior**], m., *a landing.*

**ēiciō**, -jēcī, -jectus, -icere, [ex-jacio], 3. v. a., *cast out, drive out, cast up* (cf. **edo**). — With reflex., *rush out, rush.*

**ējectus**, -a, -um, p.p. of **icio**.

**ējiciō**, see **icio**.

**ējusmodī** [**eius modi**], as adj. phrase, *of this kind, of such a kind, such, of such a nature, of this nature.*

**ēlābor**, -lāpsus, -lābī, [ex-labor], 3. v. dep., *slip out, escape.*

**ēlāpsus**, -a, -um, p.p. of **elabor**.

**ēlātus**, -a, -um, p.p. of **effero**.

**Elaver**, -veris, [Celtic], n., a tributary of the Loire, now *Allier*.

**ēlectus**, -a, -um, p.p. of **eligo**.

**elephantus**, -ī, [Gr. acc. ἐλέφαντα, declined], m., *an elephant.*

**Eleuteti**, -ōrum, [Celtic], m. plur., (a doubtful reading), a people dependent on the Arverni.

**Eleutheri**, -ōrum, [Celtic], m. plur., (a doubtful reading), a supposed name of the Cadurci.

**ēliciō**, -licuī, -licitus, -licere, [ex-lacio], 3. v. a., *entice out, draw out*.

**ēligō**, -lēgī, -lēctus, -ligere, [ex-lego], 3. v. a., *pick out, select*. — **ēlēctus**, -a, -um, p.p. as adj., *picked* (troops).

**Elusātes**, -um, [Celtic], M. plur., a people of Aquitania.

**ēmigrō**, -āvi, -ātūrus, -āre, [ex-migro], 1. v. n., *remove* (permanently), *emigrate*. — With **domo** (in same sense).

**ēmineō**, -nuī, no p.p., -nēre, [ex-mineo], 2. v. n., *stand out, project*.

**ēminus** [ex manu, cf. **cominus**], adv., *at a distance, at long range*.

**ēmittō**, -mīsī, -missus, -mittere, [ex-mitto], 3. v. a., *let go, drop, send out, throw, hurl, discharge*. — Pass., or with reflex., *rush out*.

**emō**, emī, emptus, emere, [√EM?], orig. *take*], 3. v. a., (*take*, only in compounds). — Esp., *buy* (cf. Eng. *sell*, orig. *give*), *purchase*.

**ēnāseor**, -nātus, -nāscī, [ex-naseor], 3. v. dep., *spring out, grow out*.

**ēnātus**, -a, -um, p.p. of **enaseor**.

**enim** [prob. e (in **en**, **ecce**) + **nam**], adv., *really*. — Esp., as explanatory, *for, but, now*: **neque enim** (*for of course . . . not*).

**ēnitor**, -nīsus (-nīxus), -nītī, [ex-nitor], 3. v. dep., *struggle out* (or *up*).

**ēnūntiātus**, -a, -um, p.p. of **enuntio**.

**ēnūntiō**, -āvi, -ātus, -āre, [ex-nuntio], 1. v. a., *make known, report, disclose*.

**eō**, ivī (iī), itum, īre, [√I, cf. Gr. εἶμι, for AYAMI], irr. v. n., *go, pass, march*.

**eō** [old dat. of **is**], adv., *thither, there* (in sense of *thither*). — Often

translated by more def. expressions in Eng., *to the place* (where, etc.), *on them* (*it, him, etc.*).

**eō**, see **is**.

**eōdem** [old dat. of **idem**, cf. **eo**, *thither*], adv., *to the same place, in the same place* (cf. **eo**), *there also*: **eodem conduxit** (*to the same place* [as himself]); **eodem pertinere** (*look in the same direction, tend the same way*); **eodem illo pertinere . . . ut** (*avored the same idea . . . that*).

**ephippiātus**, -a, -um, [ephippia- (as if stem of verb) + **tus**, cf. **auratus**], adj., *caparisoned*: **equites** (*riding on saddles, as a less manly form of horsemanship*).

**ephippium**, -ī, [Gr. ἐφίππιον (ἐπί, upon; ἵππος, a horse)], N., *a horse-cloth, caparison, housing*.

**epistula** (**epistola**), -ac, [Gr. ἐπιστολή], F., *a letter, a note, a message* (in writing), *a despatch*.

**Eporedorix**, -igis, [Celtic], M., a nobleman of the Hædui.

**epulum**, -ī; plur. -ae, -ārum, [?], N. (sing.), F. (plur.), *a feast, a banquet*.

**eques**, -itis, [equō + **tis** (reduced)], M., *a horseman, a rider*. — Plur., *cavalry*. — Esp. (as orig. serving on horseback), *a knight* (one of the moneyed class at Rome, next in rank to the senate). — So also, *a knight* (of Gaul, of a corresponding class).

**equester**, -tris, -tre, [equit + **tris**], adj., *of knights, of cavalry*.

**equidem** [e (in **en**, **ecce**) - **quidem**], adv., (particle of asseveration), *surely, at least*. — Often untranslatable in Eng. exc. by emphasis, change of order of words, or some similar device.

**equitātus**, -tūs, [equitā- (as stem

of **equito**) + **tus**], M., *cavalry*, *horse* (troops serving on horseback).

**equus**, -ī, [√AK + **vus**, *swift*], M., *a horse*.

**Eratosthenēs**, -is, [Greek], M., a Greek philosopher and mathematician of Alexandria, born at Cyrene B.C. 276. He was famous for his investigations in geography and astronomy.

**ērectus**, -a, -um, p.p. of **erigo**.

**ēreptus**, -a, -um, p.p. of **eripio**.

**ergā** [prob. instr. of same stem as **ergo**], prep., *towards* (of feeling and conduct): **benevolentia erga aliquem**.

**ergō** (-ō rarely) [unc. form, perh. dat., cf. **erga**], adv. with gen., *for the sake of*. — Alone, *therefore, then*.

**ērigō**, -rēxī, -rectus, -rigere, [**ex-rego**], 3. v. a., *set up straight* (cf. **rego**), *raise up*. — With reflex., *get up*. — **ērectus**, -a, -um, p.p. as adj., *high, high and straight*.

**ēripiō**, -ripiū, -reptus, -ripere, [**ex-rapio**], 3. v. a., *snatch away, wrest* (a thing from), *deprive* (one of a thing, changing the relation in Eng.), *take from, rescue*: **se eripere ne** (*save one's self from* doing a thing).

**errō**, -āvi, -ātūrus, -āre, [?], 1. v. n., *wander, go astray, err, be mistaken*.

**ērumpō**, -rūpi, -ruptus, -rumpere, [**ex-rumpo**], 3. v. a. and n., *burst out, sally out, make a sally*.

**ēruptiō**, -ōnis, [**ex-ruptio**, cf. **erumpo**], F., *a breaking out, a sally*.

**essedā**, -ae (-um, -ī), [Celtic], F. (and N.), *a war-chariot* (of the Gauls).

**essedārius**, -ī, [essedō(-a) (reduced) + **arius**], M., *a charioteer* (a warrior fighting from an **essedum**).

**Esuvii**, -ōrum, [Celtic], M. plur.,

a Gallic tribe in the region of Normandy.

**et** [akin to Gr. **ἐτι**], conj., *and*. **et . . . et** (*both . . . and*).

**etiam** [et jam], conj., *also, even*: **quin etiam** (*nay more*).

**etsi** [et si], conj., *even if, although, though*.

**ēvādō**, -vāsī, -vāsūrus, -vādere, [**ex-vado**], 3. v. n., *escape*.

**ēvellō**, -vellī (-vulsī), -vulsus, -vellere, [**ex-vello**], 3. v. a., *pull out*.

**ēveniō**, -vēnī, -ventūrus, -venire, [**ex-venio**], 4. v. n., *come out, turn out, happen*.

**ēventus**, -tūs, [**ex-†ventus**, cf. **conventus** and **evenio**], M., *result, issue, fate, success*.

**ēvocātus**, -a, -um, p.p. of **evoco**.

**ēvocō**, -āvī, -ātus, -āre, [**ex-voco**], 1. v. a., *call out, call forth, summon, challenge* (**ad pugnam**), *carry away* (**cupiditas longius**), *invite* (**omnes ad se spe praedae**). — **ēvocātus**, -a, -um, p.p. as adj. and subst., *veteran* (of soldiers who have served their time and are only called out in emergencies), *veterans* (almost equal *volunteers*).

**ēvolō**, -āvī, -ātūrus, -āre, [**ex-volo**], 1. v. n., *fly out, rush out*.

**ex** (ē) [?], adv. (in comp.) and prep., *out of* (cf. **ab**, *away from*), *out*. — Less exactly, *from* (lit. and fig.), *of* (made of): **facilia ex difficillimis redegerat** (*had made easy instead of most difficult, as they were*). Hence, *after*. — Also, *on account of, in accordance with, by means of*. — Also, *above* (raised from). — Also (cf. **ab**), *in, on*: **una ex parte** (*on one side*); **ex itinere** (*on the march, starting from it*); **ex vinculis** (*in chains, doing something from them*); so, **ex equis** (*on horseback*); **ex**

eorum corporibus; **ex ea civitate** (*from that nation, belonging there*); **ex fuga** (*in their flight*).— Other phrases: **ex commutatione dolere** (*suffer from the change*); **diem ex die** (*day after day*); **magna ex parte** (*in a great degree, for the most part*); **quaerere ex** (*ask of, ask, cf. ab*); **ex eo plus doloris capere** (*on this account, etc.*); **ex cratibus** (*of, made of*); **unus e filiis** (*one of, etc.*); **ex communi consensu** (*by common consent*); **ex percontatione** (*by inquiry, from one which was made*); **ex Hispania** (*a man from*); **ex eo die quintus** (*from, after*); **ex usu** (*for the advantage, cf. "of use"*); **ex planitie editus** (*above, raised out of*); **e regione** (*opposite*); **ex litteris** (*in accordance with, from facts stated in, etc.*); **ex tertia parte aestimare** (*as a third, cf. heres ex asse*); **ex contrario** (*on the contrary*).

**exāctus**, -a, -um, p.p. of **exigo**.

**exagitō**, -āvi, -ātus, -āre, [**exagito**], I. v. a., *pursue, drive, harass, persecute*.

**exāminātus**, -a, -um, p.p. of **examino**.

**exāminō**, -āvi, -ātus, -āre, [**examin-** (stem of **examen**, *tongue of the balance*)], I. v. a., *weigh*.

**exanimātus**, -a, -um, p.p. of **exanimo**.

**exanimō**, -āvi, -ātus, -āre, [**exanimō-**], I. v. a., *deprive of breath (life), kill*.— **exanimātus**, -a, -um, p.p. as adj., *out of breath, exhausted*.

**exardēscō**, -arsī, no p.p., **ardēscere**, [**ex-ardesco**], 3. v. n., *blaze up*.— Fig., *become enraged, become excited*.

**exaudiō**, -īvi, -ītus, -īre, [**exaudio**], 4. v. a., *hear (from a distance)*.

**excēdō**, -cēssī, -cēssūrus, -cēdere, [**ex-cedo**], 3. v. n., *go out, leave (with abl.), withdraw, retire*.— Absolutely, *leave the fight*.

**excelsus**, -a, -um, [p.p. of **ex-cello**], as adj., *high, elevated*.

**exceptō**, -āvi, -ātus, -āre, [**ex-cpto**, cf. **excipio**], I. v. a., *catch up*.

**exceptus**, -a, -um, p.p. of **excipio**.

**excidō**, -cīdī, -cīsus, -cīdere, [**ex-caedo**], 3. v. a., *cut out, cut off, break down (gates)*.

**excipiō**, -cēpī, -ceptus, -cipere, [**ex-capio**], 3. v. a., *take off, take up, pick up, receive, catch (of animals)*. Hence, *follow, come after, come next*: **vada** (*stand, of vessels*); **vim fluminis** (*break*); **alios alii** (*succeed*); **hunc alii** (*follow, take up the cry in shouting*).

**excitātus**, -a, -um, p.p. of **excito**.

**excitō**, -āvi, -ātus, -āre, [**excito**, cf. **exciteo**], I. v. a., *call out, rouse, stimulate (induce)*.— Also, *raise (towers), kindle (fire)*.

**exclūdō**, -clūsī, -clūsus, -clūdere, [**ex-claudo**], 3. v. a., *shut out, cut off (from doing a thing), prevent*.

**exclūsus**, -a, -um, p.p. of **excludo**.

**excōgitō**, -āvi, -ātus, -āre, [**excogito**], I. v. a., *think out, devise*.

**excruciātus**, -a, -um, p.p. of **excrucio**.

**excrucio**, -āvi, -ātus, -āre, [**ex-crucio**], I. v. a., *torture, torment*.

**excubitor**, -tōris, [as if **ex-†cu-bitor**, cf. **excubo**], M., *a sentinel (as lying out of the camp or tent)*.

**excubō**, -cubui, -cubitūrus, -cubāre, [**ex-cubo**], I. v. n., *lie outside*.— Esp. of camp, *stand guard, keep a night-watch, watch*.



**exculcō**, -āvi, -ātus, -āre, [ex-calco], 1. v. a., *tread down, trample down*.

**excurrō**, -curri (-cucurri), -currus, -currere, [ex-curro], 3. v. n., *run out, make a sally*.

**excursiō**, -ōnis, [ex-cursio, cf. **excurreo**], F., *a sally*.

**excūsatiō**, -ōnis, [ex-†causatio, cf. **excuso**], F., *an excuse*.

**excūsō**, -āvi, -ātus, -āre, [ex-†causo], 1. v. a., *give as an excuse*. — Also (with change of relation), *excuse, exculpate*.

**exemplum**, -i, [ex-†templum, √EM (in **emo**) + lus (cf. **querulus**), with parasitic p], N., (*something taken out*), *a sample, a copy, a precedent, an example*. — See also **edo** (*put forth*).

**excō**, -ivī (-iī), -itum, -īre, [ex-eo], irr. v. n., *go forth, go out, emigrate, march out, remove*.

**exerceō**, -ercui, -ercitus, -ercere, [ex-arceo], 2. v. a., *train, practise, exercise*.

**exercitātiō**, -ōnis, [exercitā-(stem of **exercito**) + tio], F., *practice, exercise*.

**exercitātus**, -a, -um, p.p. of **exercito**.

**exercitō**, -āvi, -ātus, -āre, [exercitō-, cf. **exerceo**], 1. v. a., *train, practise*. — **exercitātus**, -a, -um, p.p. as adj., *trained*. — Superl., *very well trained*.

**exercitus**, -tūs, [as if **ex-arcitus**, cf. **exerceo**], M., (*a training*). — Concretely, (*a body trained or in training*), *an army* (large or small, acting independently), *a force*.

**exhauriō**, -hausi, -haustus, -haurire, [ex-haurio], 4. v. a., *drain off*. — Less exactly, *carry off* (earth).

**exigō**, -ēgi, -āctus, -igere, [ex-

ago], 3. v. a., (*lead out*), *pass, spend, finish, complete*: **exacta hiems** (*the end of winter*); **aestas exacta erat** (*was ended*).

**exiguē** [abl. of **exiguus**], adv., *scantily, meagrely*: **exigue habere frumentum** (*have a scanty supply of, etc.*).

**exiguitās**, -tātis, [exiguō + tas], F., *scantiness, meagreness*: **temporis** (*short time, want of time*); **pellium** (*small size*); **castrorum** (*narrowness, small size*).

**exiguus**, -a, -um, [ex-†aguus (√AG + uus), cf. **exigo**], adj., (*exact?*), *narrow, scanty, small, meagre*.

**eximius**, -a, -um, [ex-†emius (√EM + ius), cf. **eximo**], adj., (*taken out*), *exceptional, remarkable, very high* (*opinio*).

**exīstimātiō**, -ōnis, [ex-aestimatio, cf. **existimo**], F., *estimate, opinion*.

**exīstimō**, -āvi, -ātus, -āre, [ex-aestimo], 1. v. a. and n., *estimate, believe, think, suppose, imagine*.

**exitus**, -tūs, [ex-itus, cf. **exeo**], M., (*a going out*), *a passage* (out, concretely). Hence, *an end, the last part*: **quem habere exitum** (*what is the result of, etc.*). — Fig., *a result, a turn* (of fortune), *an issue*.

**expectō** and compounds of **ex** with **s**, see **exs**.

**expediō**, -ivī, -itus, -ire, [prob. †expedi-(stem of adj. from **ex-pes**)], 4. v. a. and n., *disentangle, disencumber, set free* (cf. **impedio**). — Less exactly and fig., *set in order, get ready, arrange, station* (of troops). — **expeditus**, -a, -um, p.p. as adj., *unincumbered, easy* (*iter*), *not difficult, quick, active, light-armed* (of troops), *in light march-*

ing order (of troops without baggage), *mobile* (of troops).

**expeditiō**, -ōnis, [as if ex-†pedi- + tio, cf. **expedio**], F., (*light-armed service?*), a getting ready, a despatching. Hence, an expedition: *misit in expeditionem (detached)*.

**expellō**, -puli, -pulsus, -pellere, [ex-pello], 3. v. a., *drive out*. — Fig., *dispel*.

**experior**, -pertus, -periri, [ex-†perior, pass. of **pario**, cf. **op-terior**], 4. v. dep., (*get for one's self?*), *experience, try: fortunam (risk, try, bear, endure)*.

**expertus**, -a, -um, p.p. of **experior**.

**expiātus**, -a, -um, p.p. of **expio**.

**expiō**, -āvi, -ātus, -āre, [ex-pio], 1. v. a., (*purify*), *expiate*. — Transferred to the signs of divine wrath, *expiate: incommodum (wipe out, i.e. make good, retrieve)*.

**expleō**, -plēvi, -plētus, -plēre, [ex-pleo], 2. v. a., *fill out, fill up, make up* (filling the required measure).

**explōrātor**, -tōris, [as if ex-†plorator, cf. **exploro**], M., a scout, a pioneer (as a means of reconnoitring, cf. **speculator**, a spy).

**explōrātus**, -a, -um, p.p. of **exploro**.

**explōrō**, -āvi, -ātus, -āre, [exploro, prob. *search* by calling or crying], 1. v. a., *investigate, explore, search, examine, reconnoitre*. — **explōrātus**, -a, -um, p.p., *assured, certain: explorata victoria (being assured of victory); habere omnia explorata (know certainly)*.

**expōnō**, -posui, -positus, -pōnere, [ex-pono], 3. v. a., *place out, set out: exercitum (disembark, also draw up, array)*. — Fig., *set forth* (in speech).

**exportō**, -āvi, -ātus, -āre, [exporto], 1. v. a., *carry out, carry away, export*.

**exposeō**, -poposci, no p.p., -poscere, [ex-posco], 3. v. a., *demand* (with eagerness).

**exprimō**, -pressi, -pressus, -primere, [ex-premo], 3. v. a., *press out, force out: vocem (elicit, get out of one)*. — Also (cf. **edo**), *raise up: turre agger* (as the mound of circumvallation rose with the towers on it as it approached the city).

**expūgnātiō**, -ōnis, [ex-pugnatio, cf. **expugno**], F., a storming (of a city), *taking* (of a city by storm).

**expūgnātus**, -a, -um, p.p. of **expugno**.

**expūgnō**, -āvi, -ātus, -āre, [expugno], 1. v. a., *take* (by storm), *capture* (by storming a city): *stipendiariis expugnatis* (the cities of their tributaries sacked).

**expulsus**, -a, -um, p.p. of **expello**.

**exquirō**, -quisivi, -quisitus, -quirere, [ex-quaero], 3. v. a., *search out, inquire, ask for*.

**exquisitus**, -a -um, p.p. of **exquiro**.

**exsequor**, -secutus, -sequi, [exsequor], 3. v. dep., *follow out, follow up: jus (enforce)*.

**exserō**, -serui, -sertus, -serere, [ex-sero], 3. v. a., (*disentangle*), *thrust out, uncover*.

**exsertus**, -a, -um, p.p. of **exsero**.

**existō**, -stiti, -stiturus(?), -sistere, [ex-sisto], 3. v. n., *stand out, rise up, come out: malacia (ensue); motus (break out); cornu (grow out)*.

**expectō**, -āvi, -ātus, -āre, [expecto], 1. v. a. and n., *look out for, wait for, wait, wait to see* (*si, whether, etc.*), *expect, anticipate*.

**exspoliō**, -āvi, -ātus, -āre, [ex-spolio], 1. v. a., *strip off*.—Also, *strip of* (cf. **despolio**).—Fig., *deprive, rob* (of, abl.).

**exstinctus**, -a, -um, p.p. of **exstinguo**.

**exstinguō**, -stinxi, -stinctus, -stinguere, [ex-stinguo], 3. v. a., (*punch out, as a fire in the woods?*), *extinguish* (lit. and fig.), *destroy, put an end to*.

**extō**, -stiti, -stātūrus(?), -stāre, [ex-sto], 1. v. n., *stand out*: **ex aqua** (*be above*).

**exstructus**, -a, -um, p.p. of **exstruo**.

**exstruō**, -struxi, -structus, -struere, [ex-struo], 3. v. a., *heap up, build up, pile up*.

**exsul**, -ulis, [ex-√SAL (of **salio**, cf. **praesul**) as stem, with some lost connection of meaning, cf. **consul**], C., *an exile*.

**exter**, -tera, -terum, [ex + **terus** (reduced)], adj., *outer, outside*.—

**extrēmus**, -a, -um, superl., *farthest, extreme, last*: **extremi**, as subst. (*the rear*); **in extremis lingulis** (*at the extremity of, etc.*, and often in this sense); **ad extremum** (*till the last, at last*); **ad extremum producta casum** (*to the last extremity*); **ab extrema parte** (*at the very end*); **in extrema spe** (*almost in despair*); **in extremis suis rebus** (*in the last extremity*); **extrema fames** (*the last extremity of hunger*).

**exterreō**, -terruī, -territus, -terrere, [ex-terreo], 2. v. a., *frighten away, frighten greatly, terrify*.

**exterritus**, -a, -um, p.p. of **exterreo**.

**extimēscō**, -timui, no p.p., -timēscere, [ex-timesco], 3. v. a. and n., *fear greatly, fear (much), dread*.

**extorqueō**, -torsī, -tortus, -torquere, [ex-torqueo], 2. v. a., *wrench from, wrest from, force from*.

**extortus**, -a, -um, p.p. of **extorqueo**.

**extrā** [abl. or instr.(?) of **exter**, cf. **supra**], adv. and prep., *outside, out of*.

**extrāctus**, -a, -um, p.p. of **extrahō**.

**extrahō**, -traxi, -trāctus, -trahere, [ex-trahō], 3. v. a., *drag out*: **multum aestatis** (*drag out, waste*).

**extrūdō**, -trūsi, -trūsus, -trūdere, [ex-trudo], 3. v. a., *thrust out, push out*.

**exuō**, -ui, -ūtus, -uere, [ex-unc. verb, cf. **induo**], 3. v. a., *strip off*: **armis exutis** (*deprived of arms*).—Also (cf. **despolio**), *strip, deprive, despoil*: **Romanos impedimentis**.

**exūrō**, -ūssi, -ūstus, -ūrere, [ex-uro], 3. v. a., *burn up*.

**exūtus**, -a, -um, p.p. of **exuo**.

## F.

**faber**, -brī, [√FA (DHA? in **facio**) + **ber** (for **brus**)], (M. of **faber**, *skilful*), *a mechanic, an engineer* (in an army).

**Fabius**, -ī, [? **faba-** (*bean*) + **ius**, cf. **Cicero**], M., a Roman gentile name.—Esp.: 1. **Quintus Fabius Maximus** (Allobrogicus), who conquered the Arverni in B.C. 121 on the Rhone.—2. **Gaius Fabius**, a legatus of Cæsar in Gaul.

**facilis**, -e, [†**facō-** (cf. **beneficus**) + **lis**], adj., *easy* (to do, cf. **habilis**), *convenient, without difficulty, easy* (generally).—**facile**, N. as adv., *easily, conveniently, without difficulty*.

**facinus**, -oris, [†**facin-** (as if root of †**facino**, longer form of **facio**, cf. **prodino**) + **us**], N., a *deed* (of any kind). — Esp. (as in English), a *deed* (of crime), a *misdeed*, a *crime*, *guilt* (referring to some particular act), *criminal conduct*.

**faciō**, **fēci**, **factus**, **facere**, [√**FAC** (DHHA + K) + **io** (YA)], irr. v. a. and n., *make, do, act*. — Used in a great variety of senses as in Eng.: **conjunctionem** (*form*); **sementes** (*do planting*); **iter** (*march, travel, proceed*); **vim** (*use violence, force a passage, offer resistance*); **rates** (*build*); **testudinem** (*form*); **ea** (*perform*); **pacem** (as in Eng.); **finem orandi** (*put an end to, stop, etc., cease, etc.*); **phalangem** (*form*); **fidem** (*give assurance, also gain belief, gain credence*); **gratum** (*do a favor*); **senatus consultum** (*make, pass*); **verba** (*speak, act as spokesman*); **potestatem** (*give an opportunity, permit, allow*); **satisfacere** (*do enough, satisfy*). — Esp. with clause of result, *cause* (to), *do* (omitting in Eng. the connective *that*, and expressing the thing done in the indicative). — So in pass., *be done, be caused, happen, result, ensue, occur, turn out, be*: **non sine causa fit** (*it is not without reason*); **fit ut** (*the result is*); **fieri posse** (*be possible*); **quid fit** (*what is going on*); **fit gratulatio** (*one is congratulated*). — Often with two accs. (or with adj. corresponding to second acc.), *make, render*: **vectigalia deteriora** (*make less, diminish*). — Esp.: **certiorem facere** (*inform*). — So with pred. gen.: **nihil reliqui ad celeritatem** (*leave nothing undone, leave no further possibility*); **sui commodi naves** (*make for his convenience*).

— **factum**, -i, N. of p.p., half noun and half participle, and to be translated by either, *act, thing done, etc.*: **id factum graviter tulit** (*took this action much to heart*); **recte factum** (*good conduct, but notice the adverb*); **si quid opus factum** (*if anything was necessary to be done*). — **fiō, fieri**, as pass. in all senses.

**factiō**, -ōnis, [prob. †**facti** + o, but treated as √**FAC** + **tio**, cf. **cohortatio**], F., a *business, an employment*. — Also, a *party, a faction*.

**factum**, -i, see **facio**.

**factus**, -a, -um, p.p. of **facio**.

**facultās**, -tātis, [**facul** (for **facili**, cf. **simul**) + **tas**], F., *ease, facility*. — So, *chance, power, opportunity*: **quantum facultatis dari potuit** (*so far as opportunity was offered*); **sui colligendi** (*chance to, etc.*). Hence, concretely, *means, resources, supply*: **navium**; **facultates ad largiendum**.

**fāgus**, -i, [prob. √**BHAG**, *eat*, + **AS** (-**us**), from the fruit], F., a *beechness* (of the timber).

**fallō**, **fefellī**, **falsus**, **fallere**, [? **SPHAL**, *trip up*], 3. v. a. and n., *deceive*: **spes aliquem** (*disappoint*); **fallendo** (*by deceit*). — **falsus**, -a, -um, p.p., *deceived*. — Also (transferred to things), *false, unfounded*.

**falsus**, -a, -um, p.p. of **fallō**.

**falx**, **falcis**, [?], F., a *sickle, a pruning-hook*. — Also, a *hook* (of similar form for demolishing walls).

**fāma**, -ae, [√**FA** (in **for**) + **MA**], F., *speech, common talk, reputation*. — Concretely, a *rumor, a story*.

**famēs**, -is, [?], F., *hunger, starvation*: **famem tolerare** (*keep from starving, appease hunger*).

**familia**, -ae, [**famulō**- (reduced, cf. **famul**) + **ia**], F., a *collection of*

*attendants, a household.*—Applied to Gaul, a clan, retainers.

**familiāris**, -e, [prob. *familiā* + *ris*, but treated as *famili* + *aris* (cf. *alaris*, *animalis*)], adj., of the household: *res* (*estate, property*).—Esp. as subst., a friend.

**familiāritās**, -tātis, [*familiari* + *tas*], F., *intimacy* (*with, genitive*).

**fās** [√FA (in *for*) + *as*], indecl. N., *right* (in conscience, or by divine law): *non est fas* (*permitted, allowed*).

**fastigātē** [abl. of p.p. of *fastigo*], adv., *sloping*.

**fastigātus**, -a, -um, p.p. of *fastigo*.

**fastigium**, -ī, [†*fastigō*- (unc. form akin to *fastus*, *scorn*, cf. *castigo*) + *ium*, cf. *fastigo*], N., *elevation, slope, descent* (of a slope).

**fastigō**, -āvī, -ātus, -āre, [†*fastigō*- (cf. *fastigium*)], I. v. a., *bring to a point*.—Esp. **fastigātus**, -a, -um, p.p. as adj., *inclined, sloping*.

**fātum**, -ī, [N. of *fatus*, p.p. of *for*], N., (*what is spoken*, cf. *fas*), *fate, lot*.

**faveō**, fāvī, fautūrus, favēre, [?], 2. v. n., *favor*.

**fax**, facis, [?], F., a torch, a firebrand, fire (lighted missiles).

**fēlicitās**, -tātis, [*felici-* (as if *felici-*) + *tas*], F., *good fortune, good luck, lucky star*: *summa* (*perfect success*).

**fēliciter** [*felici-* (as if *felici-*) + *ter*], adv., *happily, fortunately, luckily, successfully*.

**fēmina**, -ae, [*fe-* (stem of *feo*) + *mina*, cf. *alumna*], F., a woman, a female.

**femur**, -oris, [?], N., the thigh.

**fera**, see *ferus*.

**ferāx**, -ācis, [reduced noun-stem (akin to *fero*) + *ax*, as if †*ferā* +

*cis* (reduced), cf. *opacus*], adj., *fertile*.

**ferē** [?, abl. of stem †*ferō*- (akin to *fero*, cf. *Lucifer*)], adv., *almost, about*.—Also, *almost always, generally, usually, for the most part*.—With negatives, *hardly*.

**ferō**, tuli, lātus (for *tlātus*), *ferre*, [√BHAR, *bear*, and √TOL (TLA) in *tollo*], irr. a. and n., *bear, carry, endure, tolerate, stand, withstand, carry off, win*.—Often in a loose sense, translated by various special words in Eng., *commit, offer*, etc.—With reflex. or in pass., *rush, pass, proceed, roll* (of a river).—With advs. indicating manner of receiving anything, *suffer, bear, take it, feel*: *acerbius ferre inopiam* (*suffer severely from*); *magno cum dolore ferre* (*be much pained or indignant at*); *molestē (graviter) ferre* (*be annoyed at, take hard, be indignant at*).—Special uses: *responsa* (*carry away, receive*); *auxilium* (*carry aid, assist*); *arma* (*bear arms, fight*); *signa* (*bear on the standards, march*); *ventus ferebat* (*carried the ships, blew*); *consuetudo fert (is)*; *opinio fert (goes)*; *ut natura montis ferebat* (*according to the outline of the mountain*).

**ferrāmentum**, -ī, [as if *ferrā-* (stem of verb from *ferrum*) + *mentum*], N., a tool (of iron).

**ferrāria**, -ae, [F. of *ferrarius*], F., an iron mine.

**ferreus**, -a, -um, [*ferrō* + *eus* (-YAS)], adj., of iron, iron (made of iron).

**ferrum**, -ī, [?], N., iron, steel.

**fertilis**, -e, [†*ferti* + *lis*, (as if √FER+*tilis*)], adj., *fertile, fruitful*.

**fertilitās**, -tātis, [*fertili* + *tas*], F., *fertility*.

**ferus**, -a, -um, [√FER (DIVAR, *rush*) + us, cf. *deer*], adj., *wild, ferocious*. — Fem. as subst., *wild beast, game*.

**fervēfaciō**, -fēcī, -factus, -facere, [†ferve- (case-form akin to *ferveo*) + facio], irr. v. a., *heat, heat red-hot* (*jacula*).

**fervēfactus**, -a, -um, p.p. of *fervefacio*.

**ferveō**, ferbui (fervī), no p.p., *fervere*, [noun-stem akin to *febris*], 2. v. n., *be hot, be red-hot*.

**fībula**, -ae, [√FIG (in *figo*) + bula], F., *a clasp, a buckle*.

**fictus**, -a, -um, p.p. of *figo*.

**fidēlis**, -e, [fidē- (stem of *fides*) + lis], adj., *faithful*.

**fidēs**, -ei, [√FID (BHID, *bind*) + es], F., *a promise, a pledge: laedere* (*break faith*); *fidem facere* (*give assurance*). — Also, *good faith, fidelity*. — Transferred, *confidence, faith* (in); *fidem facere* (*gain credence*). — Esp. of promised protection, *protection, dependence, alliance: quorum in fide erat civitas* (*to whom ... was subject, under whose protection*); *in fidem se permittere* (*place themselves under protection of, etc.*).

**fidūcia**, -ae, [†fiduc- (†fidu + eus, reduced, cf. *ferax*) + ia], F., *confidence, reliance*.

**figūra**, -ae, [†figu- (√FIG, in *figo*, + us) + ra, F. of *rus*], F., *shape, form*.

**filia**, -ae, [F. of *filius*], F., *a daughter*.

**filius**, -ī, [?], M., *a son*.

**figō**, finxi, fictus, fingere, [√FIG, cf. *figura*], 3. v. a., *mould*. — Fig., *invent, contrive*. — **fictus**, -a, -um, p.p. as adj. and subst., N. pl., *fictions: ficta respondeant* (*make up answers*).

**finiō**, -ivī (-iī), -itus, -ire, [fini-], 4. v. a., *set bounds to, limit, bound, measure* (ending a division).

**finis**, -is, [?], M., *a limit, an end: finem facere* (*put an end to, cease*); *quem ad finem* (*as far as*). — Plur., *boundaries, limits, territories, country*.

**finitimus**, -a, -um, [fini + timus], adj., *on the borders, neighboring, adjacent, neighbors* (of). — Plur. as subst., *neighbors*. — Also, *finitimus*.

**fiō** [√FU in *fui*], as passive of *facio*, which see.

**firmiter** [firmō + ter], adv., *firmly, stoutly, steadily*.

**firmitūdō**, -inis, [firmō + tudo], F., *solidity, strength* (of resistance).

**firmō**, -āvī, -ātus, -āre, [firmō-], 1. v. a., *make strong, strengthen, fortify*.

**firmus**, -a, -um, [√DHAR + mus], adj., *strong* (for resistance), *firm, steady: pars hostium minime firma* (*weakest*).

**fistūca**, -ae, [?], F., *a pile-driver*.

**flāgitō**, -āvī, -ātus, -āre, [as if †flagitō-, p.p. of †flago, akin to *flagrum*], 1. v. a., *ask* (in heat?), *demand earnestly: Haeduos frumentum* (*grain of the Aeduans*).

**flamma**, -ae, [√FLAG + ma], F., *flame, fire*.

**flectō**, flēxī, flexus, flectere, [?], 3. v. a., *bend, turn*.

**fleō**, flēvī, flētus, flēre, [?], 2. v. a. and n., *weep: flentes* (*in tears*).

**flētus**, -tūs, [fle- (stem of *fleo* as root) + tus], M., *weeping, lamentation: magno fletu* (*with many tears*).

**flō**, flāvī, flātus, flāre, [?], 1. v. n. and a., *blow*.

**flōrēns**, -entis, [pres. p. of *floreo*], as adj., *blooming*. — Fig., *flourishing, prosperous, influential* (*juve-*

nis): *florentissimis rebus* (in most prosperous circumstances).

**flos**, *flōris*, [?], M., a flower. — Fig., the flower (of troops).

**fluctus**, -tūs, [√FLU(G) (in *fluo*, cf. *fluxi*) + *tus*], M., a wave.

**flūmen**, -inis, [√FLU(G) (in *fluo*, cf. *frumentum*) + *men*], N., a river.

**fluō**, *flūxi*, *fluxus* (*fluxūrus*, *fluctūrus*, *fluitūrus*), *fluere*, [√FLU(G), cf. *fruo*], 3. v. n., flow.

**fodiō**, *fōdi*, *fossus*, *fodere*, [?], 3. v. a., dig.

**foedus**, -eris, [√FID (in *fides*, cf. *fīdus*) + *us*], N., a treaty.

**fōns**, *fontis*, [?], M., a fountain, a spring.

**fore**, see *sum*.

**forem**, see *sum*.

**foris** [abl. plur. of *fora*], as adv., out of doors. — Less exactly, outside (beyond the siege lines).

**forma**, -ae, [DHAR (in *firmus*) + *ma*], F., shape, form.

**fors**, *fortis*, [√FER + *tis* (reduced)], F., chance. — **forte**, abl. as adv., by chance, perchance, accidentally, as it happened.

**forte**, see *fors*.

**fortis**, -e, [akin to *firmus*], adj., strong, brave: *vir fortis* (a man of courage).

**fortiter** [*forti*+*ter*], adv., bravely, stoutly, undauntedly: *fortius factum* (any deed of prowess).

**fortitūdō**, -inis, [*forti*+*tudo*], F., bravery, prowess.

**fortuitō** [abl. of †*fortuitus*, p.p. of verb in -uo, cf. *fortuna*], adv., by chance, accidentally, fortuitously.

**fortūna**, -ae, [†*fortu*- (√FER + *tus*, cf. *fortuito*) + *na*, F. of -nus], F., fortune, chance, fate, lot (one's fortune), chances (*belli*), success (good or bad). — Plur., *fortunes*,

*resources, chances* (means) of success. — Esp., good fortune, success: *fortunam temptare* (try one's chances).

**fortūnātus**, -a, -um, [p.p. of *fortuno*], as adj., fortunate.

**forum**, -ī, [akin to *fora*], N., (an open place), a market-place. — Esp., the Forum (the great market-place of Rome).

**fossa**, -ae, [F. of *fossus*, p.p. of *fodio*], F., a ditch, a trench.

**fovea**, -ae, [?, perh. akin to *foveo*, as a pit for storage], F., a pitfall.

**fractus**, -a, -um, p.p. of *frango*.

**frangō**, *frēgi*, *fractus*, *frangere*, [√FRAG], 3. v. a., break (as a solid body). — Esp. of ships, wreck. — Fig., break down, crush.

**frāter**, -tris, [prob. √FER + *ter*, cf. *pater*], M., a brother.

**frāternus**, -a, -um, [*frater* + *nus*], adj., of a brother, fraternal: *nomen* (the name of brothers).

**fraus**, *fraudis*, [?, akin to *frustra*], F., loss. Hence, *treachery, deceit*.

**fremitus**, -tūs, [*fremi*- (stem of *fremo*) + *tus*], M., a murmur, a confused noise, a roar.

**frequēns**, -entis, [orig. pres. p. akin to *farcio*], adj., crowded, numerous, in great numbers.

**frētus**, -a, -um, [root akin to *firmus* + *tus*], adj., relying on, confident in (on account of).

**frigidus**, -a, -um, [†*frigō*- (whence *frigeo*) + *dus*], adj., cold.

**frīgus**, -oris, [√FRIG (in *frigeo*, etc.) + *us*], N., cold. — Plur., cold (cold "snaps," frosts).

**frōns**, *frontis*, [?, akin to *brov*], F., brow, face: *a media fronte* (from the middle of the forehead). — Less exactly, front, brow: *a fronte* (in front).

**fructuōsus**, -a, -um, [fructu + osus], adj., *fruitful*.

**frūctus**, -tūs, [√FRU(G) + tus], M., *enjoyment*. Hence, (*what one enjoys*), *fruit* (of the earth, or of any kind of labor), *crops*, *income*: *victoriae* (*advantages of victory*).

**frūmentārius**, -a, -um, [frumentō- (reduced) + arius], adj., of *grain*: *loca* (*fruitful in grain*); *res* (*grain supply, provisions*); *inopia* (*scarcity of grain*).

**frūmentātiō**, -ōnis, [frumentā- (stem of *frumentor*) + tio], F., *foraging, gathering grain, harvesting*.

**frūmentor**, -tātus, -tārī, [frumentō-], I. v. dep., *forage, gather grain*.

**frūmentum**, -ī, [FRU(G) + mentum], N., *grain* (cf. *fructus*).

**fruor**, frūctus, fruī, [√FRU(G)], cf. *fruges*], 3. v. dep., *enjoy*.

**frūstrā** [abl. or instr. of stem akin to *fraus*], adv., *to no purpose, without effect*.

**Fūsius** (-sius), -ī, [?], M., a Roman gentile name. — Esp., *Gaius Fufius Cita*, a Roman knight doing business at Cenabum, killed by the Gauls.

**fuga**, -ae, [√FUG + a], F., *flight*: *fit fuga* (*a rout ensues*); *fugae mandare se* (*take to flight*); *fugam petere* (*seek safety by flight, escape*); *ex fuga evaserat* (*had escaped from the flying crowd*).

**fugātus**, -a, -um, p.p. of *fugo*.

**fugō**, fūgī, fugitūrus, fugere, [√FUG (in *fuga*)], 3. v. a. and n., *fly, fly from*. — Fig., *shun, avoid*.

**fugitīvus**, -a, -um, [fugi- (stem of *fugio*?) + tivus], adj., *runaway*. — Plur. as subst., *runaway slaves*.

**fugō**, -āvī, -ātus, -āre, [fugā-], I. v. a., *put to flight, rout*.

**fūmō**, -āvī, -ātus, -āre, [fumō-], I. v. n., *smoke*.

**fūmus**, -ī, [√FU (DHU) + mus, akin to *dust*], M., *smoke*. — Plur., *smoke* (in several columns).

**funda**, -ae, [akin to *fundo*, perh. Gr., cf. σφενδόνη], F., *a sling*.

**funditor**, -tōris, [funda (as if verb-stem) + tor, cf. *viator*], M., *a slinger*.

**fundō**, fūdi, fūsus, fundere, [√FUD], 3. v. a., *pour*. — Less exactly, *scatter*. — Esp. of battle, *put to rout, rout*.

**fungor**, functus, fungī, [?], 3. v. dep., *perform* (abl.).

**fūnis**, -is, [?], M., *a rope*.

**fūnus**, -eris, [unc. root (akin to Gr. φόνος?) + us], N., (*murder?*), *death, a funeral*.

**furor**, -ōris, [√FUR (cf. *fuero*) + or], M., *madness, frenzy, fury*.

**furtum**, -ī, [N. p.p. of lost verb akin to *fur, thief*], N., *theft, a theft*.

**fūsilis**, -e, [fuso- (p.p. of *fundo*) + lis, cf. *flexilis*], adj., (*capable of being poured*), *molten* (of metals).

**Fūsius**, -ī, [perh. akin to *fundo*], M., a Roman gentile name. See *Fufius*.

**futūrus**, see *sum*.

## G.

**Gabali**, -ōrum, [Celtic], M. plur., a Gallic people, dependants of the Arverni.

**Gabīnius**, -ī, [Gabinō- (cf. *Gabii*) + ius], M., a Roman gentile name. — Esp., *Aulus Gabinius*, consul with Lucius Piso in B.C. 58.



**gaesum**, -ī, [Celtic], N., a *javelin*.  
**Gājus** (Cājus, C.), -ī, [?], M., a Roman prænomen.  
**Galba**, -ae, [Celtic, meaning *fat*], M., a Gallic and Roman family name. — Esp.: 1. *Servius Sulpicius Galba*, a legatus of Cæsar. — 2. A king of the Suessiones.  
**galea**, -ae, [?], akin to **galerus**], F., a *helmet* (of leather, worn by cavalry).  
**Gallia**, -ae, [F. of adj. in **-ius**, **Gallo + ius**], F., *Gaul*, including all the country bounded by the Po, the Alps, the Rhine, the ocean, the Pyrenees, and the Mediterranean, thus occupying all northern Ita'y, France, and Belgium.  
**Gallicus**, -a, -um, [Gallō + **cus**], adj., of the *Gauls*, *Gallic*.  
**gallīna**, -ae, [gallo- (a *cock*) + **ina**], F., a *hen*.  
**Gallus**, -a, -um, [Celtic], adj., of *Gaul*, *Gallic*. — As subst., a *Gaul*, the *Gauls*. — Also, as a Roman family name. — Esp., *Marcus Trebius Gallus*, a military tribune in Cæsar's army.  
**Garumna**, -ae, [Celtic], C., a river of S.W. Gaul, now the *Garonne*.  
**Garumnī**, -ōrum, [Celtic], M. pl., a Gallic tribe in the Pyrenees, on the head waters of the *Garonne*.  
**Gates**, -um, [Celtic], M. plur., a Gallic people of Aquitania.  
**gaudeō**, gāvīsus, gaudēre, [†gavidō- (?), cf. **audeo**], 2. v. n., *be delighted, rejoice*.  
**gāvīsus**, -a, -um, p.p. (neut. pass.) of **gaudeo**.  
**Geldumnī** (-dūnī), -ōrum, [Celtic], M. plur., a Belgian tribe, dependants of the *Nervii*.  
**Gēnabēnsis**, see **Cenabensis**.  
**Gēnabum**, see **Cenabum**.  
**Genāva**, -ae, [Celtic], F., a city

of the *Allobroges*, at the outlet of Lake *Leman*, now *Geneva*.

**gener**, -erī, [?], M., a *son-in-law*.  
**generātim** [as if acc. of †**generatis** (**generā + tis**)], adv., *by tribes*.  
**gēns**, gentis, [√GEN + **tis** (reduced)], F., a *tribe, a clan, a people*.  
**Genua**, -ae, a less correct spelling for **Genava**.

**genus**, -eris, [√GEN + **us**], N., a *generation, a race, a family (stock), a nation, a tribe*. — Less exactly, a *kind, a sort, a class*. — Also, abstractly, *kind, character, nature, method (pugnae)*: **genus hominum** (*the character of the inhabitants*).

**Gergovia**, -ae, [Celtic], F., a city in the lands of the *Arverni*.

**Germānī**, see **Germanus**.

**Germānia**, -ae, [F. of adj. in **-ius**, cf. **Gallia**], F., *Germany*, the whole country between the Rhine, the Danube, the Vistula, and the sea.

**Germānicus**, -a, -um, [Germanō + **cus**], adj., of the *Germans*, *German*, *Germanic*.

**Germānus**, -a, -um, [?], adj., *German* (of the country of *Germany* or its people. The name of the people is the original, but as usual is an adjective). — Plur. as subst., *the Germans*.

**gerō**, gessī, gestus, gerere, [√GES, of unc. kin.], 3. v. a., *carry* (indicating a more lively action than **fero**), *carry on, manage, wage (war), hold (a magistracy), do (any business)*. — Pass., *be done, go on* (of operations): **rem bene (male)** (*operate successfully or otherwise, carry on operations, succeed well or ill*); **negoti bene gerendi** (*of successful action*); **his rebus gestis** (*after these operations*); **res gestae** (*exploits, operations, a campaign*).

**gestus**, -a, -um, p.p. of **gero**.

**gladius**, -ī, [?], M., a sword.  
**glæba** (glē-), -ae, [?], F., a clod (of earth), a lump.

**glāns**, glandis, [?], F., a nut, an acorn. — Also, a ball (for shooting).

**glēba**, see **glæba**.

**glōria**, -ae, [?, for †**clovosia**, cf. **inclutus**], F., fame, glory.

**glōrior**, -ātus, -ārī, [gloriā-], I. v. dep., glory in, boast of (abl.).

**Gnaeus** (Cnējus, Cn.), -ī, [akin to **gnavus**], M., a Roman prænomen.

**Gobannitiō**, -ōnis, [Celtic], M., one of the Arverni, uncle of Vercingetorix.

**Gorgobina** (Gergovia), -ae, [Celtic], F., a city in the territory of the Hædui, founded by the Boii emigrating from Cisalpine Gaul.

**Graecus**, -a, -um, [Gr. Γραικός], adj., of the Greeks, Greek. — As subst., a Greek, the Greeks. Cf. **Germanus** for relation of noun and adj.

**Grājoceli**, -ōrum, [?], M. plur., a people of the Alps, near Mont Cenis.

**grandis**, -e, [?], adj., large, of great size.

**grātia**, -ae, [gratō- (reduced) + ia], F., "gratefulness" (in both Eng. senses of *grateful*), *gratitude* (that one has from others or towards others), *good-will*, *favor*. Hence, *influence*, *friendship*, *source of influence*, *ground of friendship*. — Esp.:

**gratias agere** (*express gratitude*, *render thanks*, *thank*); **gratias habere** (*feel gratitude*, *be grateful*); **gratias [gratiam] referre** (*make a grateful return*, *pay off an obligation*, *requite*); **gratiam inire** (*secure the gratitude of any one*, *conciliate*). — With gen., *for the sake of*, *on account of*, *for*, *to* (for the purpose of): **purgandi gratia** (*to excuse one's self*).

**grātulātiō**, -ōnis, [gratulā + tio, cf. **frumentatio**], F., a congratulation (of others or one's self), *rejoicing*: **fit gratulatio** (*there is great rejoicing*).

**grātulor**, -ātus, -ārī, [†gratulō- (gratō + lus)], I. v. dep., *congratulate*.

**grātus**, -a, -um, [p.p. of lost verb], adj., *pleasing*, *grateful*: **gratum facere** (*do a favor*).

**gravis**, -e, [for †**garvis**, for †**garus**, cf. Gr. βαρύς], adj., *heavy*. — Fig., *serious*, *severe*, *hard*: **gravioris aetatis** (*more advanced years*); **si gravior quid acciderit** (*if anything serious should occur*); **caerimonia** (*solemn*, *binding*); **ne quid gravior statueret** (*that he would not pass any very severe judgment*).

**gravitās**, -tātis, [gravi + tas], F., *weight*. — Fig., *importance*, *power*.

**graviter** [gravi + ter], adv., *heavily*, *with greater weight*, *with force*. — Fig., *severely*, *seriously*: **graviter ferre** (*take to heart*, *suffer from*); **premere** (*press hard*); **multo gravior exarsit** (*more violently*).

**gravō**, -āvī, -ātus, -āre, [gravi- (as if gravā-)], I. v. a., *make heavy* (cf. **levo**). — Pass. as dep., (*make heavy for one's self*), *be reluctant*, *be unwilling*, *object*.

**Grudii**, -ōrum, [Celtic], M. plur., a Belgian people, dependants of the Nervii.

**gubernātor**, -tōris, [gubernā + tor], M., a pilot, a helmsman.

**gustō**, -āvī, -ātus, -āre, [†gustō- (stem akin to **gustus**, Gr. γεύω, Eng. *choose*)], I. v. a., *taste*, *eat*.

**Gutruātus**, -ī, [Celtic], M., a leader of the Carnutes.

## H.

**habeō**, habuī, habitus, habēre, [?, †habō- (cf. **habilis**)], 2. v. a. and n., *have, hold, keep, occupy, possess*: **sedes**; **equitatum circum se**; **aditum** (*have in itself, and so offer*); **castra** (*occupy*); **se habere** (*be*); **quantum in se habet** (*as much as there is in, etc.*); **secum habere** or **apud se** (*have with him, also detain*); **censum** and the like (*hold, conduct*); **contentiones** (*carry on*); **orationem** (*deliver*).—Esp. with p.p. as a sort of continued perfect (wh. the perf. of modern languages), *have, hold, keep*: **redempta habere** (*buy up and hold*); **civitates obstrictas** (*keep under obligation*); **equitatum coactum** (*get and keep*).—Also, *treat*: **pro amico**. Hence, *consider* (cf. *hold*): **pro explorato** (*consider certain*).—Esp.: **rationem habere**, *keep an account, take an account of, have regard for, consider, regard, act in view of*: **satis habere** (*be satisfied, be content*); **habere quemadmodum oppida defendere** (*have any means of, etc.*).

**Haeduus** (**Aed-**), -a, -um, [Celtic], adj., *of the Hædui*, a powerful Gallic tribe between the Loire and the Saône.—As subst., *a Hæduan, the Hædui*.

**haesitō**, -āvi, -ātūrus, -āre, [as if †haesitō- (as if p.p. of **haereo**, for **haeseo**, cf. **dictito**)], freq. of **haereo**, 1. v. n., *get caught, stick, struggle* (*caught in a marsh*).

**hāmus**, -ī, [?], M., *a hook*.

**harpagō**, -inis, [Gr. ἄρπαγμα (Latinized) + o], M., *a hook* (esp. for walls, like a fire-hook), *a grappling-iron*.

**Harūdes**, -um, [Teutonic], M. pl., *a German tribe originally from Jut-*

land, remaining from the great expedition of the Cimbri.

**haud** [?], adv., *not* (negating single words).

**Helvēticus**, -a, -um, [**Helvetiō-** (reduced) + **cus**], adj., *Helvetian* (see **Helvetius**).

**Helvētius**, -a, -um, [Celtic], adj., *of the Helvetii* (a tribe between the Lake Lemman, the Rhone, and the Rhine). Cf. **Germanus** for the form.—As subst. plur., *the Helvetii, the people*.

**Helvii**, -ōrum, [Celtic], M. plur., *a Gallic tribe in the Roman province*.

**Hercynius** (**Orcyn-**), -a, -um, [Teutonic], adj. (only with **silva**), *Hercynian* (the great forest embracing all the mountain country of Germany).

**hērēditās**, -tātis, [hered- (as if heredi-) + **tas**], F., *inheritance, an inheritance*.

**hibernāculum**, -ī, [hibernā- (stem of **hiberno**) + **culum**], N., (*place to winter*).—Plur., *winter quarters* (esp. of the tents or camp, cf. **hiberna**, the general word).

**Hibernia**, -ae, [?], F., *Ireland*.

**hibernus**, -a, -um, [hiem + **ernus**, cf. **nocturnus**], adj., *of winter, winter* (as adj.).—Neut. pl. (sc. **castra**), *winter quarters, a winter encampment*.

**hic** [†hi- (loc. of hi-e) ce], adv., *here* (cf. **hīc**), *in this place, there* (of a place just mentioned).

**hīc**, haec, hōc, hūjus, [hi- (pron. stem) + ce, cf. **ecce, cetera**], pron., (pointing to something near the speaker in *place, time, or interest*), *this, these, he, they, this man (woman or thing)*.—Referring to things before mentioned (but with more emphasis than **is**): **hic pagus unus**

(*this one canton*); **ex his qui arma ferre possent** (*of these* [before enumerated], *those who*, etc.). — Less commonly, of what follows: **his mandatis** (*the following, as follows, these*). — Esp.: **haec memoria** (*the present generation*): **tempus** (*the present*); **his paucis diebus** (*within a few days*). — **hoc**, neut. abl., used adverbially, *in this respect, on this account, by so much*. — Often where a more definite word is used in Eng.: **his ita respondit** (*to this embassy*). — Often **hic . . . ille**, *the one . . . the other, this (near by) . . . the other (farther off), this last (nearer on the page) . . . the other, the latter . . . the former*.

**hiemō**, -āvī, -ātūrus, -āre, [hiem- (as if hiema-)], I. v. n.

**hiemps**, -emis, F., *winter*.

**hinc** [†him (loc. of †hi) + ce], adv., *from here, hence*.

**Hispānia**, -ae, [Hispanō + ia (F. of -ius)], F. (of adj., cf. Gallia), *Spain*.

**Hispānus**, -a, -um, [?], adj., *Spanish*.

**hodie** [ho (abl. of hi-c, wh. see) die], adv., *to-day, now*.

**homō**, -inis, [prob. humō + o], c., *a human being* (cf. vir, *a man*, as a male), *a man* (including women).

**honestus**, -a, -um, [honus (orig. stem of honor) + tus], adj., *esteemed, respected, worthy, honorable*.

**honor** (-ōs), -ōris, [unc. root + or], M., *honor, respect*: **honoris causa** (*out of respect*). — Also, *honorable position*.

**honōrificus**, -a, -um, [honor (as if honori) -†ficus (cf. beneficus)], adj., *honorable (giving honor)*.

**honōs**, see honor.

**hōra**, -ae, [Gr. ὥρα, orig. *season*], F., *an hour* (of the day). — The Romans divided their day into twelve

hours from sunrise to sunset, which were not of equal length at all times of the year, but were always so many twelfths of the solar day.

**horreō**, horruī, no p.p., horrēre, [†horrō- (√HORR, orig. hors) + us, prob. used orig. of the sensation called "goose pimples," where the hair seems to stand on end. In Sk. the root is used of intense delight, which is sometimes accompanied by the same sensation], 2. v. n. and a., *bristle* (see above). Hence, *shudder at, dread*.

**horribilis**, -e, [horrō- (as if stem of horreo, but prob. stem of †horrus, see above) + bilis], adj., *to be shuddered at, frightful, dreadful*.

**horridus**, -a, -um, [†horrō- (wh. horreo) + dus], adj., *horrible, dreadful*.

**hortātus**, -a, -um, p.p. of hortor.

**hortor**, -tātus, -tārī, [for horitor, freq. of old †horior], 1. v. dep., *encourage, urge on, urge, address*. — Less exactly, of things, *urge, move, prompt*.

**hospes**, -itis, [prob. GHAS-PATIS, orig. *host (lord of eating)*], M., *a host*. — Also, *a guest, a stranger*. Hence, *a guest friend* (in the peculiar relation of **hospitium**, which was a kind of hereditary friendship between persons of different countries, not personal, but of a family or state), *a friend* (of the kind above mentioned): **familiaris et hospes** (*a personal and family friend*).

**hospitium**, -i, [hospit + ium], N., *the relation of host (or guest)*. Hence (cf. hospes), *friendship*: **hospitium atque amicitia** (*alliance and friendship, family and personal friendship*); **hospitio Ariovisti utebatur** (*was in friendly relations with, etc.*).

**hostis**, -is, [ $\sqrt{\text{GHAS}}$  (cf. **hospes**) + **tis**], C., (orig. *guest*), a *stranger*, an *enemy* (of the state), the *enemy* (collectively, either sing. or plur.).

**hūc** [**ho-** (dat. of **hi-**, see **hic**) + **ce**], adv., *hither*, *here* (in sense of *hither*), *to this* (place, and so forth, cf. **eo**): **huc accedebant** (*to these [ships before mentioned] were added*, cf. **accedo**); **accedebat huc** (*in addition to this fact there was*, etc.).

**hūjūsmođi**, see **hic** and **modus**.

**hūmānitās**, -tātis, [**humanō** + **tas**], F., *humanity* (as opposed to brutishness), *civilization*, *cultivation*, *refinement*, *courtesy*.

**hūmānus**, -a, -um, [stem akin to **homo** and **humus**(?) + **nus**], adj., *civilized*, *cultivated*, *refined*.

**humerus**, see **umerus**.

**humilis**, -e, [**humō** + **lis**], adj., *low*, *shallow* (cf. **altus**, *deep*).—Fig., *low*, *humble*, *poor*: **Urbios humiliores redegerunt** (*humbled, rendered less important*).

**humilitās**, -tātis, [**humili** + **tas**], F., *lowness*, *shallowness*.—Fig., *humble position*.

## I.

**I.**, sign for **unus**, etc., *one*.

**ibī** [old case-form of **is** (cf. **tibi**)], adv., *there* (in a place before mentioned).

**Iccius**, -ī, [?], M., a nobleman of the Remi.

**ictus**, -tūs, [ $\sqrt{\text{IC}}$  (in **ico**) + **tus**], M., a *stroke*: **ictus scorpionis** (*a shot of*, etc.).

**Id.**, abbrev. for **Idus**.

**idcirco** [**id** (n. acc. of **is**) -**circo** (case-form of same stem as **circa**, **circum**)], adv., *for that reason*, *for this reason*.

**idem**, eadem, idem, [**is dem**, cf. **dum**], adj. pron., *the same*.—Often as subst., *the same thing* (*things*), *the same*: **eadem quaerit** (*makes the same inquiries*); **idem castellum** (*this very fort*).

**identidem** [prob. **iden**-†**tadem** (case-form of  $\sqrt{\text{TA}}$ , in **tam** + **dem**)], adv., *repeatedly*, *again and again*.

**ideō** [**id eo**, *this for this reason*], adv., *therefore*, *for this reason*.

**idōneus**, -a, -um, [?, akin to **idem**?], adj., *fit*, *suitable*, *adapted*: **homo** (*capable*); **tempestatas** (*favorable*).

**Idūs**, -uum, [?, perh. akin to **aestus**], F. plur., *the Ides* (a day of the lunar month falling at the full moon, conventionally on the 15th of March, May, July, October, and the 13th of the other months, and used by the Romans to reckon dates).

**ignis**, -is, [unc., same word as Sk. **agnis**, *the God of fire*], M., *fire*: **igni necari** (*to be burned to death*).—Plur., *camp-fires*.

**ignōbilis**, -e, [**in**-(g)**nobilis**], adj., *not famous*, *obscure*.

**ignōminia**, -ae, [†**ignomin**- (**in**-(g)**nomen**) + **ia**], F., *want of fame*, *disgrace*.—Almost concretely, *disgraceful defeat*.

**ignōrō**, -āvi, -ātus, -āre, [**igna**-**rō**], 1. v. a., *fail to notice*, *not know*, *be ignorant of*.—Pass., *be unobserved*: **non ignorans** (*not unaware of*).

**ignōscō**, -nōvī, -nōtus, -nōscere, [**in**-(unc. which meaning) (g)**nos**-**co**], 3 v. n. and a., *pardon*.

**ignōtus**, -a, -um, [**in**-(g)**notus**], adj., *unknown*, *strange*.

**illātus**, see **inlatus**.

**ille**, -a, -ud, [old **ollus**, fr.  $\sqrt{\text{AN}}$  + **lus**(?)], pron., *that* (of some-

thing remote, cf. **hic**). — Often as subst. (opposed to some other emphatic word), *he, she, it, they*: **hic**... **ille** (*this ... that, the other, the latter ... the former*).

**illic** [loc. of **ille** + **ce**, cf. **hic**], adv., *there* (more remote, opposed to **hic**, near by), *in that place* (nation, country, etc.): **illic**... **quo** (*in the place to which*, but with more emphasis than **ibi**... **quo**).

**illigātus**, -a, -um., p.p., *attached*.

**illō** [dat. of **ille**, cf. **eo**], adv., *thither, there* (in sense of *thither*).

**illustris**, see **inlustris**.

**Illyricum**, -ī, [?, N. of adj.], N., *Illyria* (the country east of Venetia and the Adriatic, and west of Macedonia and Thrace. It belonged to Cæsar's province along with the two Gauls).

**imbēcillitās**, -tātis, [imbecillō + **tas**], F., *weakness, feebleness: animi* (*feebleness of purpose, pusillanimity*).

**imber**, imbris, [?, cf. Gr. ὄμβρος], M., *a rain-storm, a rain*.

**imitor**, -tātus, -tāri, [†imitō, p.p. of †imō (cf. **imago**)], I. v. dep., *imitate, copy*.

**immānis**, -e, [in-†manus, *good*?], adj., (*"uncanny"*?), *monstrous, huge, enormous*.

**immincō** (**imm-**), no perf., no p.p., -minēre, [in-mineo], 2. v. n., *overhang, project*. — Fig., *threaten*.

**immissus**, -a, -um, p.p. of **immitto**.

**immittō** (**imm-**), -mīsī, -missus, -mittere, [in-mitto], 3. v. a., *let in, let down* (into), *insert, throw* (upon).

**immolō**, -āvi, -ātus, -āre, [†im-mola- (**in-mola**)], I. v. a., (*sprinkle with the sacred meal*), *sacrifice*.

**immortālis**, -e, [in-mortalis], adj., *immortal*.

**immūnis**, -e, [in-†munis, cf. **communis** and **munia**], adj., *free from tribute*.

**immūnitās**, -tātis, [immuni + **tas**], F., *freedom from public burdens*.

**imparātus**, -a, -um, [in-paratus], adj., *unprepared, not ready*.

**impedimentum**, -ī, [impedi + **mentum**], N., *a hindrance: esse impedimento* (*to hinder*). — Esp. in plur., *baggage, a baggage train* (including the beasts of burden), *pack-horses*.

**impediō**, -īvi, -ītus, -īre, [†impedi- (**in-pes**, as if **impedi-**)], 4. v. a., *entangle, hamper, interfere with*. — Fig., *hinder, embarrass, impede: in iurē* (*hinder in exercise of*). — **impeditus**, -a, -um, p.p., *hampered, entangled, occupied, difficult* (*navigatio*), *impassable* (*loca*): *esse victoribus nihil impeditum* (*there is no obstacle in the way of, etc.*); **prospectus** (*interrupted*).

**impellō**, -puli, -pulsus, -pellere, [in-pello], 3. v. a., *drive on*. — Fig., *instigate*.

**impendeō**, -ēre, [in-pendeo], 2. v. n., *overhang*.

**impēnsus**, -a, -um, [p.p. of **impendo**], adj., *expensive, very high* (of price).

**imperātor**, -tōris, [imperā + **tor**], M., *commander* (in chief).

**imperātum**, -ī, [N. p.p. of **impero**], N., *an order, a command: ad imperatum* (*at one's command*).

**imperātus**, -a, -um, p.p. of **impero**.

**imperfectus**, -a, -um, [in-perfectus], adj., *unfinished: re imperfecta* (*without accomplishing one's purpose, unsuccessful*).

**imperitus**, -a, -um, [in-peritus], adj., ignorant, unacquainted with, unversed in.

**imperium**, -i, [†imperō- (whence **impero**, cf. **opiparus**) + **ium**], N., command, supreme authority, control, supremacy, supreme power, power (military), rule, sway (both sing. and plur.). — Concrete, an order, a command. — Esp.: **novis imperiis studere** (new forms of government); **nullo certo imperio** (command of any particular person); **imperii aut potestatis** (military or civil authority).

**imperō**, -āvi, -ātus, -āre, [†imperō- (in-†parus, cf. **opiparus**)], I. v. a. and n., demand (make requisition for, prob. orig. meaning), require (in same sense). Hence, order (in military sense), rule, command, give orders: **illo imperante** (under his command).

**impetrō**, -āvi, -ātus, -āre, [in-patro], I. v. a., accomplish (anything by a request), succeed in (obtaining), obtain (a request): **impetro a** (prevail upon, persuade); **ab iis impetrari ut** (they be persuaded to); **ea re impetrata** (this being granted); **si non impetraret** (if his request was not complied with); **impetro ut**, etc. (obtain a request, be allowed to, etc., succeed in having); **impetrari posse** (could be granted).

**impetus**, -ūs, [in-†petus (√PET + us), cf. **impeto**], M., a rush, an attack, an onset, a charge, an assault, violence, fury: **facere** (inroad, charge, invasion); **is impetus** (such fury, etc.); **impetus gladiatorum exceperunt** (received the charge of the enemy with drawn swords).

**impius**, -a, -um, [in-pius], adj., impious (offending divine law).

**implicātus**, -a, -um, p.p. of **implico**.

**implicō**, -āvi (-uī), -ātus (-itus), -āre, [in-plico], I. v. a., entangle, interweave, entwine.

**implōrō**, -āvi, -ātus, -āre, [in-ploro], I. v. a., implore, beseech.

**impōnō**, -posuī, -positus, -pōnere, [in-pono], 3. v. a., place upon, mount (men on horses), place, impose (fig.).

**importātus**, -a, -um, p.p. of **importo**.

**importō**, -āvi, -ātus, -āre, [in-porto], I. v. a., import.

**impositus**, -a, -um, p.p. of **impono**.

**imprimis** [in primis], adv., among the first, especially, particularly (more than anything else).

**improbus**, -a, -um, [in-probus], adj., bad, wicked, unprincipled.

**imprōvisus**, -a, -um, [in-provisus], adj., unforeseen: **improviso** (de improviso) (on a sudden, unexpectedly, unawares).

**imprūdēns**, -entis, [in-prudens], adj., not expecting, incautious, unsuspecting, off one's guard, unguarded, not being aware.

**imprudentia**, -ae, [imprudent + ia], F., ignorance, want of consideration, want of forethought.

**impūbēs**, -eris (-is), [in-pubes], adj., beardless, immature. Hence, chaste, unmarried.

**impūgnō**, -āvi, -ātus, -āre, [in-pugno], I. v. a. and n., attack, invade, charge, fight (in an offensive warfare).

**impulsus**, -a, -um, p.p. of **impello**.

**impulsus**, -sūs, [in-pulsus, cf. **impello**], M., impulse. — Fig., instigation.

**impūne** [N. of **impunis** (**in-poena**, weakened and decl. as adj.), adv., with *impunity*].

**impūnitās**, -tātis, [**impuni**+**tas**], F., *freedom from punishment, impunity*.

**imus**, -a, -um, sup. of **inferus**.

1. **in**- [cf. Gr. *α-, αν-*, Eng. *un-*], neg. particle, only in composition.

2. **in** [?, cf. Gr. *ἀνά*, Eng. *on*; cf. also **inde**], prep. *a*. With acc., of motion, having its terminus within or on (cf. **ad**, with terminus at or near), *into, upon, within, to, against, among*: **in volgus elatum est** (*spread abroad among*). — Of time, *for, to, till*. — Fig., without actual motion, but only direction, *towards, against, upon*: **in eos exempla edere** (*visit upon*); **in se voluntas** (*good will towards*). — Often where Eng. has a different conception, *in, on*: **abdere in silvas** (*hide in the woods*); **in civitates collocasse** (*had married in, etc.*); **in utram partem fluat** (*in which direction, etc.*); **in conspectum venire** (*in sight*). — In adverbial expressions where no motion appears, *in, according to, with, to*: **mirum in modum** (cf. **quem ad modum**); **in eam sententiam** (*to this purport*); **in speciem** (*with the appearance*); **in altitudinem** (*in height, cf. to the height of*). — Esp.: **in Caesarem incidit** (*happened to meet Caesar, etc.*); **in perpetuum** (*for ever*); **in Morinos** (*into the country of, etc.*); **in catenas conicere** (*throw into prison*); **in fugam conicere** (*put to flight*).

*b*. With abl., of rest (lit. and fig.), *in, on, among, within*: **in tanta propinquitate** (*under circumstances of, in a case of*); **in tanto imperio**

**P. R.** (*when the R. people had such dominion*). — Often, *in the case of, in respect to*: **in eo** (*in his case, in regard to him*). — Esp.: **in Meldis** (*in the country of*); **in ancoris** (*at anchor*); **in eo manere** (*abide by, etc.*); **in praesentia** (*for the present*); **in potestate** (*under the power*); **in opere esse** (*to be engaged in the work*); **in illo vestigio temporis positum** (*depending on, etc.*); **in eo constare** (*depend upon, etc.*). — In comp. as adv., *in, upon, towards, and the like*.

**inānis**, -c, [?], adj., *empty*. — Fig., *empty, vain, idle, mere, bare*.

**incautē** [abl. of **incautus**], adv., *incautiously, carelessly*.

**incautus**, -a, -um, [**in-cautus**], adj., *incautious, off one's guard*.

**incendium**, -ī, [**in-†candium**, cf. **incendo**], N., *a burning, a fire*: **incendia aedificiorum** (*the burning of buildings, each one being conceived as a separate burning, as is usual in Latin*).

**incendō**, -cendī, -cēsus, -cendere, [**in-†cando**, cf. **candeo**], 3. v. a., *set fire to, burn*. — Fig., *rouse, excite, fire*.

**incēsus**, -a, -um, p.p. of **incendo**.

**inceptus**, -a, -um, p.p. of **incipio**.

**incertus**, -a, -um, [**in-certus**], adj., *uncertain, dubious, untrustworthy* (**rumores**): **itinera** (*obscure, blind*).

**incidō**, -cidī, -cāsūrus, -cidere, [**in-cado**], 3. v. n., *fall upon*. — Less exactly and fig., *fall in with, meet, occur, happen*.

**incidō**, -cidī, -cīsus, -cidere, [**in-caedo**], 3. v. a., *cut into, half cut down* (*trees*).



**incipiō**, -cēpī, -ceptus, -cipere, [in-capio], 3. v. a. and n., *begin, undertake*.

**incitātus**, -a, -um, p.p. of **incito**.

**incitō**, -āvī, -ātus, -āre, [in-cito], 1. v. a., *set in motion* (in some particular direction) (lit. and fig.), *urge on, drive, impel, excite, rouse*. — **incitātus**, -a, -um, p.p., *excited to anger, angered, spurred on*: **incitato equo** (*at full gallop*); **incitato cursu** (*at full speed*). — Esp.: **se aestus incitare** (*rush in*); **se maior vis aquae incitare** (*rush more violently*).

**incōgnitus**, -a, -um, [in-cognitus], adj., *unknown*.

**incolō**, -colū, no p.p., -colere, [in-colo], 3. v. a. and n., *inhabit, live, dwell*: **incolendi causa** (*for a permanent abode*).

**incolumis**, -e, [?], adj., *unharméd, unhurt, preserved, safe, safe and sound, uninjured*.

**incommodē** [abl. of **incommodus**], adv., *inconveniently, unfortunately, badly, ill*.

**incommodus**, -a, -um, [in-commodus], adj., *inconvenient, unfortunate*. — Esp., **incommodum**, N. as subst., *disadvantage, misfortune* (euphemism for *defeat, loss, disaster*), *harm*.

**incrēdibilis**, -e, [in-credibilis], adj., *incredible, marvellous, extraordinary*.

**increpitō**, -āvī, -ātus, -āre, [as if increpitō (p.p. of increpo)], 1. v. a., *upbraid, taunt, revile*.

**incumbō**, -cubū, -cubitūrus, -cumbere, [in-cumbo], 3. v. n., *lie upon*. — Esp., fig., *bend to, exert one's self*: **animo et opibus in** (*bend one's mind and energies to*).

**incursiō**, -ōnis, [in-†cursio, cf. **incurro**], F., *an inroad, an attack, an invasion, a raid*.

**incursus**, -sūs, [in-cursus, cf. **incurro**], M., *an inroad, an attack*.

**incūsō**, -āvī, -ātus, -āre, [in-†causo, cf. **excuso**], 1. v. a., *upbraid, rebuke, chide*.

**inde** [†im (loc. of is, cf. **interim, hinc**) -de (form akin to -dem, dum, cf. **indu**, old form of **in**)], adv., *from there, thence, from the place* (which, etc.).

**indiciūm**, -ī, [indic + ium], N., *information*: **per indicium** (*through an informer*).

**indiciō**, -dixī, -dictus, -dicere, [indico], 3.v.a., *order, proclaim, appoint*.

1. **indictus**, -a, -um, p.p. of **indico**.

2. **indictus**, -a, -um, [1. **indictus**], adj., *unpleaded (causa, cf. dico)*, *untried, unheard*.

**indignē** [abl. of **indignus**], adv., *unworthily, shamefully* (unworthily of one's self or of the circumstances).

**indignitās**, -tātis, [indigno + tas], F., *unworthiness, disgrace* (cf. **indigne**), *outrage, an indignity*.

**indignor**, -ātus, -ārī, [indignō-], 1. v. dep., *be indignant* (deem unworthy of one's self).

**indignus**, -a, -um, [1. **in-dignus**], adj., *unworthy*.

**indiligēns**, -entis, [1. **in-diligens**], adj., *negligent, careless, heedless*.

**indiligenter** [in-diligenter, cf. **indiligens**], adv., *carelessly, negligently*.

**indiligentia**, -ae, [indiligent + ia], F., *carelessness, want of care, want of energy* (application).

**indūciae**, -ārum, see **indutiae**.

**indūcō**, -dūxī, -ductus, -dūcere, [in-duco], 3. v. a., *draw on*. Hence,

*cover*: *scuta pellibus*. — Also, *lead on*. Hence, *induce, instigate, impel*.

**inductus**, -a, -um, p.p. of **induco**.

**indulgentia**, -ae, [**indulgent-** (pres. p. of **indulgeo**) + **ia**], F., *indulgence, favor, clemency*.

**indulgeō**, -dulsī, -dultus, -dulgēre, [?, perh. stem compounded of **in-dulcis**, *pleasant towards*], 2. v. n., *favor, treat with indulgence*.

**induō**, -duī, -dūtus, -duere, [?, cf. **exuo**], 3. v. a., *put on*. Hence, fig. with reflex., *pierce, impale* (one's self): *se vallis*; *se stimulis* (*be pierced by*).

**industriē** [abl. of **industrius**], adv., *actively, promptly, with energy*.

**indūtia** (**indūc-**), -ārum, [?], F. plur., *a truce, an armistice*.

**Indutiomarus**, -ī, [Celtic], M., a chief of the Treviri.

**ineō**, -ivī (-ii), -itus, -ire, [**in-eo**], irr. v. a., *enter upon, go into*. — Fig., *adopt, make, begin, gain, secure*. — Esp.: *inita aestate* (*at the beginning of summer*); *inire rationem* (*take an account*).

**inermis**, -e (-us, etc.), [**in-arma**], adj., *unarmed, defenceless*.

**iners**, -ertis, [**in-ars**], adj., *shiftless, cowardly, sluggish, unmanly*.

**infāmia**, -ae, [**infami** + **ia**], F., *dishonor, disgrace*: *latrocinia nullam habent infamiam* (*bring no dishonor, are not held dishonorable*); *infamia et indignitas* (*shame and disgrace*).

**infāns**, -antis, [**in-fans**, pres. p. of **for**], C., *a child, an infant, an infant child*.

**infectus**, -a, -um, [1. **in-factus**], adj., *not done*. — Esp.: *re infecta* (*without success, cf. imperfectus*); *re infecta discedere* (*without accomplishing one's purpose*).

**inferō**, -tulī, -lātus, -ferre, [**in-fero**], irr. v. a., *bring in, import, put upon*: *in equum* (*mount one on horseback*); *bellum* (*make, of offensive war*); *signa* (*make a charge, advance*); *vulnera* (*inflict*). — Fig., *cause, inflict, commit*: *periculum* (*create, cause*); *spem* (*inspire*); *causam* (*adduce, assign, allege*).

**inferus**, -a, -um, [unc. stem (akin to Sk. *adhas*, *down*) + **rus** (cf. **superus**)], adj., *low*: *inferior pars* (*the lower end*); *ab inferiore parte* (*down below, of a river*). — Superl., **īnfirmus** (**īmus**), *lowest, the bottom of, at the bottom*: *īnfirmus collis* (*the foot of the hill*); *ad īnfirmum* (*at the bottom*). — Neut. as subst., *the bottom*.

**infestus**, -a, -um, [**in-festus**, fr. **fendo**], adj., *hostile, in hostile array*: *infestis signis* (*arrayed for fight, in a charge, in order of attack*).

**īnficiō**, -fēcī, -fectus, -ficere, [?, **in-facio**], 3. v. a., (*work into?*), *dye, stain*.

**īnfidēlis**, -e, [1. **in-fidelis**], adj., *unfaithful, wavering in faith*.

**īnfigō**, -fixī, -fixus, -figere, [2. **in-figo**], 3. v. a., *fasten in, fix in, fix on*.

**īnfirmus**, see **inferus**.

**īnfinītus**, -a, -um, [**in-finitus**], adj., *unbounded, countless, endless, numberless, infinite*.

**īnfirmītās**, -tātis, [**īnfirmō** + **tas**], F., *feebleness, unsteadiness, inconstancy*.

**īnfirmus**, -a, -um, [**in-firmus**], adj., *weak, feeble*: *animus* (*feeble courage, want of courage*); *arbores* (*unsound, weakened*); *īnfirmior* (*less powerful*); *naves* (*unseaworthy*).

**īnfixus**, -a, -um, p.p. of **īnfigo**.

**inflectō**, -flecti, -flexus, -flectere, [in-flecto], 3. v. a., *bend down*. — Pass., or with reflex., *become bent*.

**inflexus**, -a, -um, p.p. of **inflecto**.

**influō**, -fluxi, -fluxurus, -fluere, [in-fluo], 3. v. n., *flow into, empty into*.

**infodiō**, -fodi, -fossus, -fodere, [in-fodio], 3. v. a., *dig in, bury*.

**infra** [instr. (?) of **inferus**], adv. and prep., *below, farther down, less than*.

**infumus**, -a, -um, see **infimus**.

**ingēns**, -entis, [in-gens, *not belonging to the kind(?)*], adj., *huge, enormous, very large*.

**ingrātus**, -a, -um, [in-gratus], adj., *unpleasing*.

**ingredior**, -gressus, -gredi, [in-gradior], 3. v. dep., *march into, enter, march in*.

**iniciō** (**injicio**), -jēci, -jectus, -icere, [in-jacio], 3. v. a., *throw into, throw upon*. — Less exactly, *place in, put on, embark*. — Fig., *inspire*.

**inimicitia**, -ae, [inimicō + tia], F., *enmity*.

**inimicus**, -a, -um, [i. in-amicus], adj., *unfriendly, hostile*. — As subst., *an enemy* (personal, or not in war, cf. **hostis**, *an enemy of the state, or an enemy at war*), *a rival, an opponent*.

**iniquitās**, -tātis, [iniquō + tas], F., *inequality, irregularity, unevenness*. — Fig., *unfairness, unequal nature*.

**iniquus**, -a, -um, [in-aequus], adj., *uneven*. — Fig., *unjust* (of persons and things), *unfavorable, unfair, disadvantageous*. — Comp., **iniquior locus**, *less favorable position*.

**initium**, -i, [in-itiūm (itō + ium)], cf. **ineo**], N., *a beginning, the first of*: **initium capere, facere**

(*begin, start*); **transeundi** (*the initiative, the first steps, the first attempt to, etc.*); **initium fit ab** (*the start is first made*); **fugae factum** (*the first tendency to fly was shown*); **retinendi** (*the first detention*); **silvarum** (*the edge*); **Remorum** (*boundary*); **artificiorum initia** (*the first principles, the first knowledge of, etc.*).

**injectus**, -a, -um, p.p. of **inicio**.  
**injiciō**, see **inicio**.

**injungō**, -jungi, -junctus, -jungere, [in-iungo], 3. v. a., *attach to*. — Fig., *impose upon* (*his . . . servitutum*).

**injūria**, -ae, [in-jus + ia, cf. **injurius**], F., *injustice, outrage, wrong, violence* (as opposed to right), *abuse*.

**injussū** [in-jussu, abl. of **jussus**], adv., *without orders*.

**innāscor**, -nātus, -nāscī, [in-nascor], 3. v. dep., *grow in, spring up in*. — Fig., *be inspired, be excited*. — **innātus**, p.p., *natural, innate*.

**innātus**, -a, -um, p.p. of **innascor**.

**innitor**, -nisus (-nixus), -nītī, [in-nitor], 3. v. dep., *lean upon, support one's self on*. — **innixus**, p.p. in present sense.

**innocēns**, -entis, [in-nocens, p.p. of **noceo**], adj., *harmless, guiltless, innocent*.

**innocentia**, -ae, [innocent + ia], F., *blamelessness*.

**inopia**, -ae, [inop + ia], F., *scarcity, dearth, destitution, want, privation, want of supplies*.

**inopināus**, -antis, [in-opinans], adj., *unsuspecting, not expecting*.

**inquam**, [?], irr. v. n., *say*.

**inrideō**, -rīsī, -rīsūm, -rīdēre, [in-rideo], 2. v. n., *ridicule*.

**inridiculē** [old abl. of **inridiculus**], adv., *without humor*.

**inrumpō**, -rūpī, -ruptus, -rum-  
pere, [in-rumpo], 3. v. n. and a.,  
*break in, break into, storm.*

**inruptiō**, -ōnis, [in-ruptio, cf.  
**eruptio** and **inrumpo**], F., a *break-  
ing in, an attack* (on a fortified  
place).

**insciēns**, -entis, [in-sciens], adj.,  
*not knowing, unaware*: **inscientē**  
**Caesare** (*without C.'s knowledge*).

**insciūs**, -a, -um, [in-†sciūs, cf.  
**consciūs**], adj., *not knowing, un-  
aware.*

**insecūtus**, -a, -um, p.p. of **in-  
sequor**.

**insequor**, -secūtus, -sequī, [in-  
sequor], 3. v. dep., *follow up, pur-  
sue.*

**inserō**, -seruī, -sertus, -serere,  
[in-sero], 3. v. a., *insert, stick in.*

**insidiae**, -ārūm, [†insid- (cf.  
**praeses**) + **ia**], F. plur., *an am-  
bush, a stratagem, a trick, a plot, a  
trap, treachery*: **per insidias** (*with  
deception, treacherously* (cf. **per**)).

**insidiōr**, -ātus, -ārī, [insidiā-],  
1. v. dep., *lie in wait, make treach-  
erous attacks.*

**insignis**, -e, [in-signō, decl. as  
adj.], adj., *marked, memorable, sig-  
nal*. — **insigne**, N. as subst., *signal,  
sign, decoration* (of soldiers).

**insiliō**, -siluī, -sultus, -silire, [in-  
salio], 4. v. a., *leap upon.*

**insimulātus**, -a, -um, p.p. of  
**insimulo**.

**insimulō**, -āvī, -ātus, -āre, [in-  
simulo], 1. v. a., *charge, accuse.*

**insinuō**, -āvī, -ātus, -āre, [in-  
sinuo], 1. v. a. and n., *wind in*. —  
With reflex., *work one's way into,  
slip in.*

**insistō**, -stitī, no p.p., -sistere,  
[in-sisto], 1. v. a. and n., *stand  
upon, set foot upon, stand, keep one's*

*footing*. — Fig., *adopt* (**rationem  
pugnae**), *devote one's self* (in **bel-  
lum**).

**insolenter** [insolent + ter], adv.,  
(in an unusual manner), *insult-  
ingly.*

**inspectō**, -āvī, -ātus, -āre, [in-  
specto], 1. v. a. and n., *look upon,  
look on*: **inspectantibus nobis** (*be-  
fore our eyes*).

**instābilis**, -e, [in-stabilis], adj.,  
*unsteady*. — Fig., *changeable, uncer-  
tain.*

**instar** [instā + ris (? reduced)],  
N. indecl., (*an image*), *in the like-  
ness of* (with gen.), *like, in the man-  
ner of.*

**instigō**, -āvī, -ātus, -āre, [†in-  
stigō- (√STIG + US)], 1. v. a., *goad,  
stimulate, drive on, urge on.*

**instituō**, -tūi, -tūtus, -tuere, [in-  
statuo], 3. v. a., *set up, set in order,  
array*: **opus** (*finish*). — Also, *pro-  
vide, procure, get ready*. — Also, *set  
about, undertake, begin to practise,  
adopt* (a plan, etc.), *set on foot*. —  
So, *teach, train, habituate.*

**institutum**, -i, [N. p.p. of **in-  
stituo**], N., *a habit, a practice, an  
institution, a custom.*

**instō**, -stitī, -stātūrus, -stāre, [in-  
sto], 1. v. n., *be at hand, press on*.  
— Fig., *threaten, impend, menace*:  
**tempus instantis belli** (*time of  
active immediate war*).

**instructus**, -a, -um, p.p. of **in-  
struo**.

**instrūmentum**, -i, [instru +  
mentum], N., *furniture, equipment,  
tools and stores* (of soldiers).

**instruō**, -strūxī, -structus, -stru-  
ere, [in-struo], 3. v. a., *build, fit  
up, array, draw up* (of troops).

**insuēfactus**, -a, -um, [p.p. of  
**insuefacio**], p.p., *trained.*

**insuētus**, -a, -um, [in-suetus], adj., *unaccustomed, unused*.

**insula**, -ae, [akin to in-salio?], F., *an island*.

**insuper** [in-super], adv., *on the top, above, at the top*.

**integer**, -gra, -grum, [in-†teger (√TAG, in tango, + rus)], adj., *untouched, unimpaired, unwearied, fresh* (as subst., *fresh troops*). — Esp., *not entered upon* (of business); **re integra** (*before anything was done, before being committed to any course of action*).

**integō**, -tēxī, -tectus, -tegere, [intego], 3. v. a., *cover over, face* (turres coriis).

**intellegō**, -lēxī, -lēctus, -legere, [inter-lego], 3. v. a., (*pick out* [*distinguish*] *between*), *learn, know, find out, discover, see plainly, be aware*.

**intendō**, -tendī, -tentus, -tendere, [in-tendo], 3. v. a., *stretch, strain*. — Esp. of the mind or eyes, *be intent, be absorbed*: *oculis intentis* (*with eyes intent*); *animis intentis in ea re* (*with their minds absorbed in this business*).

**inter** [in + ter, cf. alter], prep. (adv. in comp.), *between, among*: *arbitros inter civitates dat* (*to decide between*); *inter aciem* (*in the line*). — Of time, *within, for*. — Often in a reciprocal sense: *inter se* (*with, to, from, etc., each other*); *cohortati inter se* (*encouraging each other*); *obsides inter eos dandos curavit* (*caused them to exchange hostages*).

**intercedō**, -cēssī, -cēssurus, -cēdere, [inter-cedo], 3. v. n., *come between, go between, lie between, intervene, exist between, occur between, be, pass* (of time): *ipsis cum Haeduis intercedere* (*exist between them and the Haedui*).

**interceptus**, -a, -um, p.p. of **intercipio**.

**intercipiō**, -cēpī, -ceptus, -cipere, [inter-capio], 3. v. a., *intercept, cut off*.

**interclūdō**, -clūsī, -clūsus, -clūdere, [inter-clando], 3. v. a., *cut off, shut off, block* (roads): *fugam* (*stop, cut off*).

**interdicō**, -dixī, -dictus, -dicere, [inter-dico], 3. v. a., (*intervene by an order*), *forbid, prohibit*: *Gallia Romanis interdicti* (*exclude the Romans, etc., by order*); *aqua atque igni* (*expel, by forbidding fire and water, the regular form of exile*); *interdicere ne* (*forbid to, order not to*).

**interdiū** [inter-diu (acc. or abl.?, akin to dies)], adv., *in the daytime, by day*.

**interdum** [inter dum (orig. acc.)], adv., *for a time, sometimes*.

**intereā** [inter ea (prob. abl.)], adv., *meanwhile, in the meantime*.

**intereō**, -ivī (-iī), -itūrus, -ire, [inter-eo (*go into pieces*?, cf. interficio)], irr. v. n., *perish, die, be killed*.

**interfectus**, -a, -um, p.p. of **interficio**.

**interficiō**, -fēcī, -fectus, -ficere, [inter-facio], 3. v. a., (*cut to pieces*, cf. **intereo**), *kill, put to death*.

**interim** [loc. of †interus, cf. **inter, interior**], adv., *meanwhile*.

**interior**, -us, [comp. of †interus (in-terus, cf. alter)], adj., *inner, interior*. — Masc. as subst.: *interiores* (*men in the interior, men in the town*).

**intericiō** (-jicio), -jēcī, -jectus, -icere, [inter-jacio], 3. v. a., *throw in* (between). — Pass., *lie between, intervene*: *spatio interjecto* (*in-*

*tervening*, i.e. *leaving a short interval*); *portubus interjectis* (*lying at intervals*); *sagittariis* (*thrown in at intervals, intermixed*).

**interjectus**, -a, -um, p.p. of **intericio**.

**intermissus**, -a, -um, p.p. of **intermitto**.

**intermittō**, -mīsī, -missus, -mittere, [inter-mitto], 3. v. a. and n., (*let go between*), *leave off, discontinue, stop, interrupt, cease*: *neque diem neque noctem* (*not cease day nor night*); *opus erat intermissum* (*was discontinued, leaving a gap*); *itinere intermisso* (*stopping their march*); *spatiis intermissis* (*leaving intervals*); *brevi tempore intermisso* (*waiting a short time*); *spatio intermisso* (*after a time*); *triduo intermisso* (*leaving an interval of, etc.*); *nocte intermissa* (*a night intervening*); *flumen intermittit* (*discontinue, leave a vacant place*); *subeuntes non intermiserunt* (*did not cease, etc.*); *dare* (*stop giving*); *intermissa profectio* (*delaying*); *vento intermisso* (*ceasing, failing*); *nocturnis temporibus ad laborem intermissis* (*ceasing their toil in the night time*); *tempus ab opere* (*at any time cease the work*); *intermittere nullum tempus quin, etc.* (*at no time cease*); *diem quin, etc.* (*let a day pass without, etc.*); *intermissae trabes* (*separated*); *intermissis magistratibus* (*passed over for a year*); *pars oppidi intermissa a flumine* (*left unprotected*); *planities intermissa collibus* (*broken by, lying between*).

**interneciō**, -ōnis, [inter-†necio, same root as **neco**], F., *extermination, annihilation* (**exercitus**).

**interpellō**, -avī, -atus, -āre, [inter-

†pello, cf. **appello**, -āre], 1. v. a., *interrupt, interfere with*.

**interpōnō**, -posuī, -positus, -pōnere, [inter-pono], 3. v. a., *put in between* (lit. and fig.), *interpose, allege* (an excuse to break off something): *nulla suspicione belli interposita* (*no suspicion, etc., appearing to hinder*); *fidem reliquis interponere* (*give a promise not to do something*); *decretum* (*put in, introduce, into the affairs of the Gauls*); *nulla dubitatione interposita* (*with no hesitation to prevent, etc.*).

**interpres**, -pretis, [inter-†pres (akin to **pretium**?), C., a mediator, an interpreter.

**interpretor**, -ātus, -ārī, [interpret-], 1. v. dep., *interpret, explain*.

**interrogātus**, -a, -um, p.p. of **interrogo**.

**interrogō**, -āvī, -ātus, -āre, [inter-rogo], 1. v. a., (*ask at intervals*), *question, interrogate*.

**interrumpō**, -rūpī, -ruptus, -rumpere, [inter-rumpo], 3. v. a., *break off* (between two points), *break down* (bridges).

**interscindō**, -scidī, -scissus, -scindere, [inter-scindo], 3. v. a., *cut off* (between two points), *break down, tear down*.

**intersum**, -fui, -futūrus, -esse, [inter-sum], irr. v. n., *be between, be among, be in, be engaged in*: *non amplius intersit* (*there is an interval of not more than, etc.*); *proelio, divinis rebus* (*be engaged in, take part in*). — Esp. in third person, *it is of importance, it interests, it concerns*.

**intervallum**, -ī, [inter-vallus, distance between stakes in a rampart], N., *distance* (between two things), *distance apart, interval*.

**intervenĭō**, -vĕnĭ, -ventŭrus, -venĭre, [inter-venio], 4. v. n., *come between, come up* (at a particular juncture), *arrive*.

**interventus**, -tŭs, [inter-†ventus, cf. **eventus** and **intervenĭo**], M., *a coming* (to interrupt something).

**intexō**, -texuĭ, -textus, -texere, [in-texo], 3. v. a., *weave in, weave together*.

**intextus**, -a, -um, p.p. of **intexo**.

**intoleranter** [intolerant + ter], adv., (*with no patience or restraint over one's self*), *fiercely, violently*.

**intrā** [instr.(?) of †**interus**, cf. **inter** and **extra**], adv. and prep., *into, within, inside*.

**intrĭtus**, -a, -um, [in-tritus (p.p. of **tero**)], adj., *unworn*. — Fig., *unexhausted*.

**intrō** [dat. of †**interus**, cf. **intra**], adv., *inside*.

**intrō**, -āvĭ, -ātus, -āre, [†**interō**], I. v. a., *enter*.

**intrōdŭcō**, -dŭxi, -ductus, -dŭcere, [intro-duco], 3. v. a., *lead in, bring in, march in* (troops).

**introeō**, -īvĭ (-īi), -itus, -ire, [intro-eo], irr. v. a. and n., *enter, come in*.

**introitus**, -tŭs, [intro-itus], M., *an entrance, an approach* (means of entrance).

**intrōmittō**, -mĭsĭ, -missus, -mittere, [intro-mitto], 3. v. a., *let go in, send in*. — With reflex. or in pass., *rush in*: **intrōmissus** (*rushing in*).

**intrōrsus** [intro-vorsus (petrified nom., p.p. of **verto**)], adv., *into the interior, inside*.

**intrōrumpō**, -rŭpĭ, -ruptŭrus, -rumpere, [intro-rumpo], 3. v. n., *break in, burst in*.

**intueor**, -tuitus (-tŭtus), -tuĕrĭ, [in-tueor], 2. v. dep., *gaze upon, gaze at, cast one's eyes upon*.

**intus** [in + tus (an abl. ending, cf. **antiquitus**)], adv., *within*.

**inŭsĭtātus**, -a, -um, [in-usitatus], adj., *unwonted, unaccustomed*: **in-usitator** (*less familiar*).

**inŭtilis**, -e, [in-utilis], adj., *of no use, unserviceable*. — In a pregnant sense, *unfavorable* (positively disadvantageous).

**invenĭō**, -vĕnĭ, -ventus, -venĭre, [in-venio], 4. v. a., *find* (come upon, cf. **reperio**, *find by search*), *learn*.

**inventor**, -tōris, [in-†ventor, cf. **invenio**], M., *a discoverer*.

**inventus**, -a, -um, p.p. of **invenio**.

**inveterāscō**, -rāvĭ, -rātŭrus, -rās-cere, [in-veterasco], 3. v. n., *grow old in, become established in*.

**invicem** [in vicem], adv., *in turn*.

**invictus**, -a, -um, [in-victus], adj., *unconquered*. — Also, *unconquerable, invincible*.

**invidĕō**, -vidĭ, -vĭsus, -vidĕre, [in-video], 2. v. n. and a., *envy, be jealous of, grudge*.

**invidia**, -ae, [invidō + ia], F., *envy, odium*.

**inviolātus**, -a, -um, [in-violatus], adj., *inviolable*. — Also (cf. **invictus**), *invulnerable*.

**invisus**, -a, -um, p.p. of **invideo**.

**invĭtātus**, -a, -um, p.p. of **invito**.

**invitō**, -āvĭ, -ātus, -āre, [?], I. v. a., *invite*.

**invitus**, -a, -um, [?], adj., *unwilling*. — Often rendered as adv., *against one's will*.

**ipse**, -a, -um, [is-potis(?)], intens. pron., *self, himself*, etc. (as opp. to

some one else, cf. **sui**, reflex. referring to the subject), *he*, etc. (emph.), *he himself*, etc.: **hoc ipso tempore** (*at this very time*); **ipse per se** (*in and of itself*); **inter se** (regular reciprocal, *each other, with each other, by each other*, etc.).

**irācundia**, -ae, [iracundō + ia], F., *wrath* (as a permanent quality, cf. **ira**, a temporary feeling), *irascibility, anger*.

**irācundus**, -a, -um, [ira + cundus], adj., *of a violent temper, passionate, irascible*.

**irrideō**, see **inrideo**.

**irridiculē**, see **inridicule**.

**irrupō**, see **inrumpo**.

**irruptiō**, see **inruptio**.

**is**, ea, id, [pron. √I], pron., *this* (less emph. than **hic**), *that* (unemph.), *these, those*, etc., *the, a, he, she, it*: **quae pars ea**, etc. (*the part which*, etc.); **eo deceptus quod**, etc. (*by the fact that*, etc.); **et id** (*and that too*); **ea quae** (*the things which, what*); **Rhodanus influit et is transitur** (*and this river*, etc.); **cum ea ita sint** (*since this is so*); **is locus quo** (*a place where*); **neque eam plenissimam** (*and that not a very full one*); **manere in eo quod**, etc. (*abide by what*). — Abl., N., **eo**, *the* (old Eng. instrumental), *so much, on that account, therefore*: **eo magis** (*all the more*); **eo gravius** (*so much the more severely*).

**ita** [√I + ta (instr. (?) of √TA)], adv., *so, in such a way, in this way, thus, as follows*: **ut... ita, ita... ut** (*in proportion as, as*).

**Italia**, -ae, [†Italō- (reduced) + ia (F. of ius)], F., *Italy* (not including the country north of the Rubicon).

**itaque** [ita que], adv., *and so, accordingly, therefore*.

**item** [√I-tem (acc.?, cf. **idem**)], adv., *in like manner, so also, in the same way* (before mentioned).

**iter**, itinēris, [stem fr. √I (go) + unc. term.], N., *a road, a march, a way, a route, a course, a journey*: **in itinere** (*on the road*); **in eo itinere** (*on the way*); **iter facere** (*march, travel*); **iter dare** (*allow to pass*); **itinere prohibere** (*forbid to pass, keep from passing*); **magnis itineribus** (*by forced marches*); **tutum iter** (*a safe passage*).

**iterum** [√I + terus, cf. **alter**], adv., *a second time, again*: **semel atque iterum** (*again and again*).

**Itius** [Celtic], adj., (with **portus**), *the port where Cæsar embarked for Britain the second time; either Calais or Boulogne*.

## J.

**jaceō**, -cui, -citūrus, -cēre, [?, cf. **jaculum**], 2. v. n., *lie, lie dead*: **jacentes** (*the slain*).

**jaciō**, jēcī, jactus, jacere, [?, cf. **jaceo**], 3. v. a., *throw, hurl, cast*: **aggerem** (*throw up*).

**jactō**, -āvi, -ātus, -āre, [jactō-], 1. v. a., (freq. of **jacio**), *toss, toss about, bandy about* (of talk).

**jactūra**, -ae, [jactu + ra (F. of rus)], F., *a throwing away, a loss, a sacrifice* (of men in war), *an offer* (of reward).

**jactus**, -a, -um, p.p. of **jacio**.

**jaculum**, -ī, [†jaciō- (cf. **iaceo**)], N., *a javelin*.

**jam** [acc. of pron. √YA], adv., *now* (of progressive time, cf. **nunc**, emphatic and instantaneous), *by this time, at last, already, at length*: **jam non** (*no longer*); **jam ante**



(some time before, even before); **jam** utebatur (*was getting to use*); **jam** reverti (*was at last, etc.; was beginning to, etc.*); **nihil jam** (*no longer*).

**juba**, -ae, [?], F., *the mane*.

**jubeō**, jūssi, jūssus, jubere, [prob. **ius-habeo**, cf. **praebeo**], 2. v. a., *order, command, bid*.

**judicium**, -ī, [judic + ium], N., *a judgment (judicial), a trial, an opinion (expressed officially); an opinion (generally), advice: optimum judicium facere (express [by some act] a very high opinion); judicio (from design)*.

**judicō**, -āvi, -ātus, -āre, [judic-], 1. v. a., *formally decide, decide, judge, adjudge, think, consider: nihil gravius de civitate (think nothing harsh about, etc.)*.

**jugum**, -ī, [√JUG (in **fungo**) + um], N., *a yoke*. Hence, *a ridge, a crest (of a row of hills)*; sub **jugum** mittere (*an insult inflicted on a conquered army, consisting in making them pass under a horizontal bar set upon two uprights*).

**jumentum**, -ī, [√JUG(?) + mentum], N., *a beast of burden, a pack-horse, a horse*.

**junctūra**, -ae, [junctu + ra (F. of -rus)], F., *a joining, a joint: quantum distabat junctura (as far as the distance apart, of two things joined)*.

**junctus**, -a, -um, p.p. of **jungo**.

**jungō**, junxi, junctus, jungere, [√JUG], 3. v. a., *join, unite, attach together*.—In pass. or with reflex., *unite with, attach one's self to*.

**jūnior**, comp. of **juvenis**.

**Jūnius**, -ī, [?, prob. **juveni** + ius, but cf. **Juno**], M., *a Roman gentile name*.—Esp., *Decimus Fu-*

*nus Brutus*, see **Brutus**.—Also, *Quintus Junius*, a Spaniard in Cæsar's service.

**Juppiter, Jovis**, [Jovis-pater], M., the god of the visible heavens and the atmosphere, who was regarded as the supreme divinity of the Romans, cf. **Zeús**.

**Jūra**, -ae, [Celtic], M., a chain of mountains in Gaul, running N.E. from the Rhone to the Rhine, separating the Sequani and the Helvetii.

**jūrō**, -āvi, -ātus, -āre, [jur- (stem of **jus**)], 1. v. n., *swear, take an oath*.

**jūs**, jūris, [for †javas, √YU (akin to √JUG) + us], N., *justice, right, rights (collectively), rights over (anything, claims)*.

**jūsjurandum, jūris jurandī**, [see the two words], N., *an oath*.

**jūssū** [abl. of †jussus], used as adv., *by order*.

**jūstitia**, -ae, [justo + tia], F., *justice (just behavior), sense of justice*.

**jūstus**, -a, -um, [jus + tus], adj., *just, lawful*.—Also, *complete, perfect, regular: populi Romani justissimum esse imperium (that the Romans were best entitled to dominion)*.

**juvenis**, -e, [?], adj., *young*.—As subst., *a young man (not over 45), a youth: juniores (the younger soldiers)*.

**juventūs**, -tūtis, [juven (orig. stem of **juvenis**) + tus], F., *youth*.—Concretely, *the youth, the young men*.

**juvō**, jūvi, jūtus, juvāre, [?], 1. v. a., *help, aid, assist*.

**jūxtā** [instr.(?) of †juxtus, sup. of †jugis (√JUG + is)], adv. and prep., *next, near, near by*.

## K.

**Kal.**, abbrev. for **Kalendae** and its cases (wh. see).

**Kalendae (Cal-)**, -ārum, [F. pl. of †**calendus**, p. of verb akin to **calo**], F. plur., *the Calends* (the first day of the Roman month, when, as it would seem, the times of the moon were *announced* to the assembled people).

## L.

**L.**, abbrev. for **Lucius**.

**L** (Ϸ), [a corrupt form of the Greek letter ψ (prop. χ), originally used for 50, and retained in the later notation], a sign for **quīnquāgintā**.

**Laberius**, -ī, [?, cf. **Labeo**], M., a Roman gentile name. — Esp., *Quintus Laberius Durus*, a tribune in Cæsar's army.

**Labiēnus**, -ī, [?, perh. **labia** + **enus**], M., a Roman family name. — Esp., *Titus Atius Labienus*, a violent partisan of Cæsar, a legatus under him in Gaul, but afterwards in the civil war on the side of Pompey.

**labor**, -ōris, [√**RABH** + **or** (for -os)], M., *toil, exertion* (in its disagreeable aspect), *labor* (as painful), *trouble*.

**lābor**, lāpsus, lābī, [unc., cf. **lābo**, **labes**], 3. v. dep., *slip, slide, fall*. — Fig., *commit an imprudence, go wrong, be disappointed*.

**labōrō**, -āvī, -ātus, -āre, [**labor-**], I. v. n., *toil, exert one's self: id contendere et laborare ne* (*strive and be anxious not to have, etc.*); *animo laborare* (*contrive, revolve in one's mind anxiously*). — Also, *suffer, labor, be hard pressed*.

**labrum**, -ī, [√**LAB** (in **lambo**, cf. **labia**) + **rum**], N., *the lip*. — Less

exactly, *the edge* (of a horn, of a ditch).

**lāc**, lactis, [?], N., *milk*.

**laccessō**, -cessivī, -cessitus, -cessere, [stem akin to **lacio** + unc. term.], 3. v. n., *irritate, provoke*. — Esp., *attack, harass, assail, skirmish with: injuria Haeduos* (*wantonly harass*).

**lacrīma**, -ae, [†**dakru-** (cf. Gr. δάκρυ) + **ma**], F., *a tear*.

**lacrīmō**, -āvī, -ātus, -āre, [**lacrima-**], I. v. a. and n., *weep*.

**lacus**, -ūs, [?, cf. **lacer**, **lacuna**], M., *a reservoir, a lake*.

**laedō**, laesī, laesus, laedere, [perh. for **laido**, √**LU** (increased) + **do** (cf. **tendo**)], 3. v. a., *wound, injure*. — Fig., esp., *break* (one's word, etc.), *violate*.

**laesus**, -a, -um, p.p. of **laedo**.

**laetātīō**, -ōnis, [**laetā** + **tio**], F., *rejoicing*.

**laetitīa**, -ae, [**laetō** + **tia**], F., *joy, gladness* (cf. **laetus**).

**laetus**, -a, -um, [unc. root (perh. akin to *glad*) + **tus**], adj., *joyful* (of the inner feeling), *rejoicing*.

**languidē** [old abl. of **languidus**], adv., *with little energy*.

**languīdus**, -a, -um, [†**languō-** (whence **languo**) + **dus**], adj., *spiritless, listless, languid: languidior* (*with less spirit*).

**languor**, -ōris, [√**LANG** (in **languo**) + **or**], M., *want of spirit, listlessness*.

**lapis**, -idis, [?], M., *a stone* (to throw, etc.). — Collectively, *stone, stones*.

**lāpsus**, -a, -um, p.p. of **labor**.

**laqueus**, -ī, [√**LAC** (in **lacio**) + **eus** (? **AYAS**)], M., *a slip-noose*.

**largior**, -ītus, -īrī, [**largō-**], 4. v. dep., *give lavishly, bestow upon, sup-*

ply with. — Also, give bribes, give presents.

**largiter** [largō + ter], adv., lavishly: largiter posse (possess abundant influence).

**largitiō**, -ōnis, [largī- (stem of largior) + tio], F., lavish giving, bribery.

**lassitūdō**, -dinis, [lassō + tudo, cf. fortitudo], F., weariness, exhaustion.

**lātē** [old abl. of latus], adv., widely: latus (too far).

**latēbra**, -ae, [latē + bra], F., a hiding-place.

**lateō**, latuī, no p.p., latēre, [?], 2. v. n., lie concealed, lurk, be concealed, pass unnoticed.

**lātitudō**, -dinis, [latō + tudo], F., breadth, width.

**Latobrigī**, -ōrum, reading for **Latovicī**, wh. see.

**Latovicī**, -ōrum, [Teutonic], M. plur., a German tribe, neighbors of the Helvetii.

**latrō**, -ōnis, [prob. stem borrowed fr. Greek + o], M., a mercenary(?), a robber.

**latrōcinium**, -ī, [latron + cinium, cf. ratiocinor], N., freebooting, robbery, highway robbery.

**lātus**, -a, -um, [prob. for †platus, cf. Gr. πλατύς], adj., broad, wide, extensive.

**latus**, lateris, [prob. latō + rus (reduced)], N., the side (of the body). — Also, generally, a side, a flank, an end (of a hill).

**lātus**, -a, -um, [for †latus, √TLA (cf. tollo, tuli) + tus], p.p. of fero.

**laudō**, -āvi, -ātus, -āre, [laud-], 1. v. a., praise, commend.

**laus**, laudis, [?], F., praise, credit, glory, merit (thing deserving praise).

**lavō**, -āvi (lāvi), -ātus (lautus,

lōtus), -āre (-ere), [?], 1. v. a., wash. — In pass., bathe.

**laxō**, -āvi, -ātus, -āre, [laxō-], 1. v. a., loosen, open out.

**lēgatiō**, -ōnis, [lēgā + tio], F., (a sending or commission), an embassy, an embassy (message of ambassadors).

**lēgātus**, -ī, [prop. p.p. of lēgo, commission, despatch], M., an ambassador. — Also, a lieutenant, a legatus. To a Roman commander were assigned (legare) one or more subordinate officers capable of taking command in his absence or engaging in independent operations under his general direction. These were the legati, and with the quæstor composed a kind of staff.

**legiō**, -ōnis, [√LEG + io], F., (a levy); hence, a legion (originally the whole levy, later the unit of army organization, numbering from 3000 to 6000 men, divided into ten cohorts).

**legiōnārius**, -a, -um, [legion + arius], adj., of a legion, of the line (the Roman heavy infantry of the legion as opposed to all kinds of auxiliary troops).

**Lemannus**, -ī, [?], M., (with lacus either expressed or implied), the Lake of Geneva, Lake Leman.

**Lemovices**, -um, [Celtic], M. pl.: 1. A Gallic tribe in modern Limousin. — 2. A doubtful reading for the name of a tribe in Brittany.

**lēnis**, -e, [?], adj., gentle.

**lēnitās**, -tātis, [leni + tas], F., gentleness, gentle current (of a river).

**lēniter** [leni + ter], adv., gently: lenius (with less vigor).

**Lepontii**, -ōrum, [Celtic], M. plur., a tribe of the Alps on the Italian side of St. Gothard.

**lepus**, -oris, [?], M., a hare.

**Leucī** (**Levacī**), -ōrum, [Celtic], M. pl., a Gallic tribe on the Moselle

**Levacī**, -ōrum, [Celtic], M. plur., a tribe of Belgian Gaul, dependents of the Nervii.

**levis**, -e, [for †**leghvis**, √LAGH + **us** (with inserted **i**, cf. **brevis**), cf. Gr. ἐλαχὺς, Eng. *light*], adj., *light, slight, unimportant, of no weight: auditio* (mere hearsay without foundation). — Also (cf. **gravis**), *inconstant, fickle, wanting in character: quid esset levius* (less dignified).

**levitās**, -tātis, [levi + **tas**], F., *lightness*. — Also (cf. **levis**), *inconstancy, fickleness*.

**levō**, -āvi, -ātus, -āre, [levi- (as if levō-)], 1. v. a., *lighten*. Hence, *free from a burden, relieve*.

**lēx**, **lēgis**, [√LEG (in **lego**)], F., a statute, a law.

**Lexovii**, -ōrum, [Celtic], M. plur., a Gallic tribe in modern Normandy.

**libenter** [libent + **ter**], adv., *willingly, with pleasure*. — With a verb, *be glad to*, etc.

**liber**, -bera, -berum, [†libō- (whence **libet**) + **rus** (reduced)], adj., *free* (of persons and things), *unrestricted, undisturbed, unincumbered*.

**liberālitās**, -tātis, [liberali + **tas**], F., *generosity*.

**liberāliter** [liberali + **ter**], adv., *generously, kindly* (**respondit**): *oratione prosecutus* (addressing in generous language).

**liberātus**, -a, -um, p.p. of **libero**.

**liberē** [old abl. of **liber**], adv., *freely, without restraint: liberius* (with too little restraint).

**liberī**, -ōrum, [prob. M. plur. of **liber**, the free members of the household], M. plur., *children*.

**liberō**, -āvi, -ātus, -āre, [liberō-], 1. v. a., *free, set free, relieve* (from some bond); **liberare se** (*secure one's freedom*).

**libertās**, -tātis, [liberō- (reduced) + **tas**], F., *liberty, freedom, independence*.

**librilis**, -e, [libra + **ilis**], adj., *of a pound weight: fundae* (heavy missiles from slings).

**licentia**, -ae, [licent + **ia**], F., *lawlessness, want of discipline*.

**liceor**, licitus, licērī, [prob. pass. of **licet**], 2. v. dep., *bid* (at an auction).

**licet**, licuit (licitum est), licēre, [†licō-, cf. **delicis**, **reliquus**], 2. v. n., *be allowed: id sibi*, etc. (*that they be allowed*); *per te licet* (*you do not hinder*); *licet conspiciari* (*one can see*); *quibus esse licet* (*who may be, who have a chance to be*).

**Liger**, -eris, [Celtic], M., a river of Gaul between the Hædui and the Bituriges, the *Loire*.

**lignātiō**, -ōnis, [lignā + **tio**], F., *getting wood*.

**lignātor**, -tōris, [lignā + **tor**], M., *wood-forager, wood-cutter*.

**lignum**, -ī, [?], N., *wood*.

**ligula**, see **lingula**.

**Ligures**, -um, [Celtic], M. plur., the *Ligurians*, a people in the north of Italy, between the Apennines and the sea.

**lilium**, -ī, [?], N., a *lily*. The name is applied jocosely to a peculiar kind of *chevaux de frise*.

**linea**, -ae, [linō + **ea** (F. of -eus)], F., a *line*.

**Lingones**, -um, [Celtic], M. plur., a Gallic tribe in the Vosges Mts.

**lingua**, -ae, [?], F., *tongue*. Hence, *language*.

**lingula**, -ae, [lingua + la (F. of -lus)], F., a little tongue, a tongue of land.

**linter** (lunt-), -tris, [?], F.(?), a trough, a skiff, a boat.

**linum**, -ī, [prob. borr. fr. Gr. λίνον], N., flax.

**lis**, litis, [for †stlis, √STLA + tis (reduced) ?], cf. locus and Eng. strife], F., a suit at law. — Also, the amount in dispute, damages.

**Liscus**, -ī, [Celtic], M., a Hæduan brother of Divitiacus.

**Litavicus**, -ī, [Celtic], M., a Hæduan chief.

**littera** (litt-), -ae, [?, akin to lino], F., a letter (of the alphabet). — Plur., letters, writing, an alphabet, a letter (an epistle).

**litus** (litt-), -oris, [?], N., a shore.

**locus**, -ī, [for †stlocus, √STLA + cus], M. (sing.), N. (generally pl.), a place, a spot, a position, a region (esp. in plur.), a point, the ground (in military language), space, extent (of space), room. — Fig., position, rank, a point, place (light, position, character), an opportunity, a chance: obsidum loco (as hostages).

**locūtus**, -a, -um, p.p. of loquor.

**longē** [old abl. of longus], adv., far, too far, absent, far away, distant: non longius mille (not more than); longe afuturum (would be far from helping); longius prodire (any distance); longius aberat (was rather far away); longe nobilissimus (far, altogether).

**longinquus**, -a, -um, [case-form of longus (perh. loc.) + cus], adj., long (of time and space), distant, long-continued.

**longitūdō**, -dinis, [longō + tūdo], F., length.

**longurius**, -ī, [longō + urius], M., a long pole.

**longus**, -a, -um, [?], adj., long (of space and time); in longiorem diem (to a more distant day); navis longa (a ship of war, a war galley, opposed to the broader naves onerariae); longum est expectare (it is too long to wait, it would take too long to, etc.).

**loquor**, locūtus, loquī, [?], 3. v. dep., speak, talk, converse.

**lōrica**, -ae, [lorō + ica], F., a coat of mail (orig. of leather thongs). — Also, a breastwork, a rampart (on a wall).

**Lucānius**, -ī, [Lucanō + ius], M., a Roman gentile name. — Esp., Quintus Lucanius, a centurion in Cæsar's army.

**Lūcius**, -ī, [luc- (in lux) + ius], M., a Roman prænomen.

**Lucterius**, -ī, [?, perh. Celtic], M., a Gallic name, perh. borrowed from the Romans. — Esp., Lucterius Cadurcus, a commander under Vercingetorix.

**Lugotorix**, -igis, [Celtic], M., a British prince.

**lūna**, -ae, [√LUC (in luceo) + na], F., the moon.

**lunter**, see linter.

**Lutētia**, -ae, [?], F., a city of the Parisii, on the site of modern Paris.

**lūx**, lūcis, [√LUC as stem], F., light, daylight: prima luce (at daybreak); orta luce (at daybreak).

**luxūria**, -ae, [†luxūrō- (luxu + rus) + ia], F., luxury, riotous living.

## M.

**M.**, abbreviation of Marcus.

**M** [corruption of CIO (orig. Φ) through influence of mille], 1000.

**māceria**, -ae, [†mācerō (wh. **macerō**) + **ia**], F., (*mortar?*), a wall.

**māchinātiō**, -ōnis, [machinā + **tio**], F., *contrivance* (mechanical). — Concretely, a contrivance, an engine, a derrick.

**maestus**, -a, -um, [p.p. of **maereo**, √MIS (in **miser**) + **tus**], adj., *sad, sorrowful, dejected*.

**Magetobri(g)a**, see **Admagetobriga**.

**magis** [√MAG (in **magnus**) + **ius** (N. comparative)], adv., *more, rather*. — See also **maxime**.

**magistrātus**, -tūs, [magistrā- (as if stem of †**magistro**) + **tus**], M., a magistracy (office of a magistrate). — Concretely, a magistrate (cf. "the powers that be").

**māgnificus**, -a, -um, [magnōficus (√FAC + **us**)], adj., *splendid, grand, magnificent*.

**māgnitūdō**, -dinis, [magnō + **tudo**], F., *greatness, great size, size, extent, stature, force* (**venti**), *severity* (**supplici**): *silvarum* (*immense woods*); *corporum* (*size, stature*).

**māgnopere**, see **opus**.

**māgnus**, -a, -um, [√MAG (*increase*) + **nus**, cf. **magis**], adj., *great* (in any sense, of size, quantity, or degree), *large, extensive, important, serious* (**motus**), *heavy* (**portoria**), *high* (**aestus**): *magni habere* (*to value highly, make much account of*); *magni interest* (*it is of great importance*). — **mājor**, comparative, in usual sense. — Also, **mājor** (with or without **natu**), *elder, older*. — In plur. as subst., *elders, ancestors*. — **māximus**, superl., *largest, very large, greatest, very great*, etc.: *maximis itineribus* (*by forced marches*). — See also **Maximus**.

**mājestās**, -tātis, [majos- (orig. stem of **major**) + **tas**], F., (*superiority*), *majesty, dignity*.

**malacia**, -ae, [borr. fr. Greek], F., (*soft weather*), a calm.

**male** [old abl. of **malus**], adv., *badly, ill*. — See also **pejus**.

**maleficium**, -ī, [maleficō + **ium**], N., *harm, mischief*.

**Mallius** (**Manlius**, **Mānilius**), -ī, [?], M., a Roman gentile name. — Esp., *Lucius Mallius*, as proconsul, beaten by the Aquitani in B.C. 78.

**mālō**, mālūi, no p.p., mälle, [mage- (for **magis**) **volo**], irr. v. a. and n., *wish more, wish rather, prefer*.

**malus**, -a, -um, [?], adj., *bad* (in all senses), *ill*. — **pējor**, comp. — **pessimus**, superl.

**mālus**, -ī, [Gr. μῆλος], M., (*apple-tree*), *mast, beam* (upright).

**mandātum**, -ī, [N. p.p. of **mando**], N., a trust (given to one), instructions (given), a message (given to some one to deliver).

**mandō**, -āvī, -ātus, -āre, [?, †**mandō** (**manu-do**)], I. v. a., *put into one's hands, entrust, instruct* (*give instructions to*), *commit*: *se fugae* (*take to*); *quibus mandatum est* (*who had been instructed*).

**Mandubii**, -ōrum, [Celtic], M. plur., a tribe north of the Hædii.

**Mandubratius** (-cius), -ī, [Celtic], M., a Briton, prince of the Trinobantes.

**mānē** [abl. of †**manis** (?), **ma** + **nis**, cf. **matuta**, **maturus**], adv., *in the morning*.

**maneō**, mānsī, mānsūrus, mānēre, [unc. stem akin to Gr. μένω], 2. v. n., *stay, remain, stay at home* (absolutely, opp. to **proficiscor**).

— Fig., *continue, stand by* (in eo quod).

**manipulāris**, -is, [manipulō + aris, prop. adj.], M., *comrade* (of the same manipulé or company).

**manipulus**, -ī, [manu + pulus (√PLE + us)], M., (*a handful, esp. of hay, used as an ensign*), *a manipule* (two centuries, a third of a cohort).

**mānsuēfaciō**, -fēcī, -factus, -facere, [†mansuē- (cf. mansuesco, and calefacio)-facio], 3. v. a., *tame*. — Pass., mānsuēfiō, *be tamed*.

**mānsuētūdō**, -dinis, [†mansue- (cf. mansuefacio) + tūdo], F., *tame-ness, gentle disposition*.

**manus**, -ūs, [?], F., *the hand*: in manibus nostris (*just at hand, within reach*); manu defendere (*by arms*); dat manus (*hold out the hands to be bound, acknowledge one's self conquered, give in*). — Also (cf. manipulus), *a company, a band, a troop*.

**Marcomannī**, -ōrum, [Teutonic, akin to *march* and *man*, "the men of the marches"?], M. plur., a supposed German tribe in the army of Ariovistus.

**Mārcus**, -ī, [?, √MAR (in morior, etc.) + cus, *the hammer*], M., a Roman prænomen.

**mare**, -is, [?], N., *the sea*: mare oceanum (*the ocean*).

**maritimus**, -a, -um, [mari + timus, cf. finitimus], adj., *of the sea, sea-, maritime, naval, on the sea*: aestus (*in the sea*); ora (*the sea-shore*); nostrum (*i.e. the Mediterranean*). — Also, **maritumus**.

**Marius**, -ī, [?], M., a Roman gentile name. — Esp., *Gaius Marius*, the opponent of Sulla and the champion of the popular against the aristocratic party. He conquered the

Cimbri and Teutones (B.C. 101) and freed Rome from the fear of a Northern invasion.

**Mars**, Martis, [?, perh. √MAR (in morior) + tis, *the slayer*, but more probably of wolves than of men in battle], M., *Mars*, originally probably a god of husbandry defending the sheep, but afterwards identified with the Greek Ἄρης and worshipped as the god of war. Cæsar again identifies him with the Celtic Hesus. — Phrase: *aequo Marte* (*with equal success*).

**mās**, maris, [?], adj., *male*. — Subst., *a male*.

**matara**, -ae, [Celtic], F., *a javelin* (of a peculiar kind, used by the Gauls).

**māter**, -tris, [?, prob. √MA (*create*) + ter], F., *a mother, a matron*.

**māter familiās** [see the words], F., *a matron*.

**māteria**, -ae (-es, -ēi), [?, prob. mater + ia (F. of -ius)], F., *wood* (cut, for material), *timber* (cf. lignum, *wood for fuel*).

**māterior**, -ātus, -ārī, [materia-], 1. v. dep., *get timber, bring wood*.

**Maticō**, -ōnis, [Celtic], F., a city of the Hædūi, now *Macon*.

**mātrimōnium**, -ī, [mater- (as if matri) + monium], N., (*motherhood*), *marriage, matrimony*: in matrimonium ducere (*marry*).

**Mātrona**, -ae, [Celtic], M., a river of Gaul, joining the Seine near Paris, the *Marne*.

**mātūrē** [old abl. of maturus], adv., *early, speedily*.

**mātūrēscō**, -tūruī, no p.p., -tūrēscere, [maturē- (cf. matureo) + sco], 3. v. n., *get ripe, ripen*.

**mātūrō**, -āvī, -ātus, -āre, [maturō-], 1. v. a. and n., *hasten, make haste*.

**mātūrus**, -a, -um, [†**matu-**(√**MA**, in **maue**, + **tus**) + **rus**], adj., *early*. — Also (by unc. conn. of ideas), *ripe, mature*.

**māximē** [old abl. of **maximus**], adv., *in the greatest degree, most, very, in the highest degree, especially*: *ea maxime ratione* (*in that way more than any other*); *maxime confidebat* (*had the greatest confidence*).

**Māximus** [sup. of **magnus**, as subst.], *M.*, a Roman family name.

**medeor**, -c̄rī, no p.p., [†**medō-** (whence **medicus**, **remedium**), root unc., cf. Gr. *μαθηάω*, but also **meditor**], 2. v. dep., *attend* (as a physician), *heal*. — Fig., *remedy, relieve*.

**mediocris**, -cre, [mediō + **cris**, cf. **iudicer**], adj., *middling, moderate*: *spatium* (*a little, no great*); *non mediocris* (*no little, no small degree of*).

**mediocriter** [mediocri + **ter**], adv., *moderately*: *non mediocriter* (*in no small degree*).

**Mediomatrici**, -ōrum (-um), [Celtic], *M. plur.*, a Gallic tribe between the Meuse and the Rhine, about Metz.

**mediterrāneus**, -a, -um, [mediō-terra + **aneus**], adj., *inland*.

**medius**, -a, -um, [√**MED** (cf. Eng. *mid*) + **ius**], adj., *the middle of* (as noun in Eng.), *mid-*: *in colle medio* (*half way up*); *locus medius utriusque* (*half way between*); *de media nocte* (*about midnight*).

**Meldi**, -ōrum, [Celtic], *M. plur.*, a tribe of Gaul.

**melior**, see **bonus**.

**Melodūnum**, -ī, [Celtic], *N.*, a city of the Senones, on an island in the Seine, now *Melun*.

**membrum**, -ī, [?], prob. formed

with suffix **-rum** (*N. of -rus*), *N.*, a limb, a part of the body.

**memini**, -isse, [perf. of √**MAN**, in **mens**, etc.], def. verb. a., *remember*.

**memoria**, -ac, [**memor** + **ia**], *F.*, (*mindfulness*), *memory, recollection, power of memory*: *memoria tenere* (*remember*); *memoriam prodere* (*hand down the memory, of something just mentioned*); *memoriam deponere* (*cease to remember*); *memoria proditum* (*handed down by tradition*); *supra hanc memoriam* (*beyond the memory of this generation*); *dignum memoria* (*worthy of remembrance*).

**Menapii**, -ōrum, [Celtic], *M. plur.*, a Gallic tribe between the Meuse and the Scheldt.

**mendācium**, -ī, [mendac + **ium**], *N.*, *falsehood, a falsehood*.

**mēns**, *mentis*, [√**MAN** + **tis** (reduced)], *F.*, (*a thought?*), *the intellect* (as opposed to the moral powers, cf. **animus**), *the mind, a state of mind*: *mentes animosque* (*minds and hearts*); *oculis mentibusque* (*eyes and thoughts*).

**mēnsis**, -is, [unc. form fr. √**MA** (cf. Gr. *μήν*, *moon, month*)], *M.*, a month.

**mēnsūra**, -ae, [†**mensu-** (√**MA**, as if **man**, + **tu**) + **ra** (*F. of -rus*)], *F.*, *measure*: *ex aqua mensurae* (*measures by the water-clock*); *itinerum* (*accurate length*).

**mentio**, -ōnis, [as if √**MAN** (in **memini**) + **tio** (prob. †**menti** + **o**)], *F.*, *mention*.

**mercātor**, -tōris, [†**mercā** + **tor**], *M.*, a trader (who carries his own wares abroad).

**mercātūra**, -ae, [†**mercātu** + **ra** (*F. of rus*)], *F.*, *traffic, trade, commercial enterprise*.



**mercēs**, -ēdis, [mercē + dus (reduced)], F., *hire, pay, wages*.

**Mercurius**, -ī, [unc. form, akin to *merces*, etc.], M., *Mercury*, the Roman god of gain, traffic, etc. Afterwards, identified with the Greek Hermes, he was considered also the god of eloquence as well as of trade, the messenger of the gods, and the god of roads, etc. He is identified by Cæsar with a Celtic divinity, probably Teutates.

**mereor**, -itus, -ērī, (also **mereo**, active), [†merō- (akin to Gr. μετρωμαι)], 2. v. dep., *win, deserve, gain*. — Also (from earning pay), *serve*: **mereri de** (*serve the interests of*).

**meridiānus**, -a, -um, [meridie + anus], adj., *of midday*: **tempus (noon)**.

**meridiēs**, -ēī, [prob. medio- (reduced) -dies], M., *midday, noon*. — Also, *the South*.

**meritum**, -ī, [N. of p.p. of **me-ro**], N., *desert, service*. — **meritō** (abl. as adv.), *deservedly*: **minus merito** (*without the fault*); **magis . . . quam merito eorum** (*more than by any act of theirs*); **merito ejus a se fieri** (*that he deserved that he should do it*).

**Messāla**, -ae, [?], M., a Roman family name. — Esp., *Marcus Valerius Messala*, consul, B.C. 61, with Marcus Piso.

**mētior**, mēnsus, mētīrī, [†meti- (√MA + tis?)], 4. v. dep., *measure, measure out, deal out* (rations, distribute).

**Metiosedum**, reading for **Melodunum**.

**Mētius** (**Mettius**), -ī, [?], M., a Gaul in relations of hospitality (see **hospes**) with Ariovistus.

**metō**, messui, messus, metere, [?], 3. v. a., *cut, reap, gather*.

**metus**, -tūs, [unc. root (perh. √MA, *think*) + tus], M., *fear*. — Often superfluous with other words of fearing: **metu territare** (*terrify*). — Esp.: **hoc metu** (*fear of this*).

**meus**, -a, -um, [√MA (in **me**) + ius], adj. pron., *my, mine*.

**mīles**, -itis, [unc. stem akin to **mille** as root + tis (reduced)], C., *a soldier, a common soldier* (as opposed to officers), *a legionary soldier* (*heavy infantry*, as opposed to other arms of the service). — Collectively, *the soldiers, the soldiery*.

**militāris**, -e, [milit + aris], adj., *of the soldiers, military*: **signa** (*battle-standards*).

**militia**, -ae, [milit + ia], F., *military service, service* (in the army).

**mille**, ind. **milia**, -ium, [akin to **miles**], adj. in sing., subst. in plur., *a thousand*: **mille passuum** (*a thousand paces, a mile*).

**Minerva**, -ae, [unc. form akin to **memini**, etc.], F., *Minerva*, the goddess of intellectual activity, and so of skill and the arts, identified with the Greek *Athene*.

**minimē** [old abl. of **minimus**], adv., *in the smallest degree, least, very little, not at all*.

**minimus**, -a, -um, [lost stem (wh. **minuo**) + imus (cf. **infimus**, superl. of **parvus**)], adj., *smallest, least*. — Neut. as subst. and adv., *the least, least, very little*.

**minor**, -us, [lost stem (cf. **minimus**) + ior (compar. ending)], adj., *smaller, less*: **dimidio minor** (*half as large*). — Neut. as subst. and adv., *less, not much, not very, not so much, not so*: **quo minus** (*in that . . . not*); **si minus** (*if not*); **minus valebat**

(not so strong, less, etc.); **minus uti** (not so well); **minus magnus fluctus** (less violent, smaller).

**Minucius** (**Minut-**), -ī, [perh. akin to **minus**], M., a Roman gentile name. — Esp., *Lucius Minucius Basilus*, a commander of cavalry under Cæsar.

**minuō**, -uī, -ūtus, -uere, [†**minu-** (cf. **minus**)], 3. v. a. and n., *lessen, weaken, diminish*: **aestus** (*ebb*); **vim** (*break the force, etc.*); **controversias** (*settle*); **desidiam** (*cure, correct*); **ostentationem** (*humble*).

**mīror**, -ātus, -ārī, [**mīrō-**], 1. v. dep., *wonder, wonder at, be surprised*. — **mīrātus**, -a, -um, p.p. in pres. sense, *surprised*.

**mīrus**, -a, -um, [?, √SMI (cf. **smile**) + **rus**], adj., *surprising, marvellous, wonderful*.

**misere**, -era, -erum, [√MIS (cf. **maereo**) + **rus**], adj., *wretched, pitiable, miserable, poor*.

**misericordia**, -ae, [**misericord** + **ia**], F., *mercy, pity, clemency*.

**miseror**, -ātus, -ārī, [†**miserō-**], 1. v. dep., *bewail, complain of*.

**missus**, -a, -um, p.p. of **mitto**.

**missus**, -sūs, [√MIT (? , root of **mitto**) + **tus**], M., *a sending*: **missu Caesaris** (*despatched by Cæsar, under orders of Cæsar*).

**mitissimē** [old abl. of **mitissimus**], adv., superl. of **mite** (N. of **mitis**), *very gently, very mildly, in very gentle terms*.

**mittō**, mīsi, missus, mittere, [?], 3. v. a., *let go* (cf. **omitto**), *send, despatch, discharge, shoot*: **sub jugum mittere** (*send under the yoke, an act of humiliation inflicted upon a conquered army*). See **jugum**.

**mōbilis**, -e, [prob. **movi-** (as if stem of **movco**, or a kindred stem)

+ **bilis**], adj., *easily moved, movable, mobile, fickle, hasty*.

**mōbilitās**, -tātis, [**mobili** + **tas**], F., *mobility, activity* (of troops), *inconstancy, fickleness*.

**mōbiliter** [**mobili** + **ter** (prob. **terum**, reduced)], adv., *easily* (of motion), *readily*.

**moderor**, -ātus, -ārī, [†**moder-** (akin to **modus**, cf. **genus, genero**)], 1. v. dep., *control, regulate, restrain*.

**modestia**, -ae, [**modestō** + **ia**], F., *moderation, self-control, subordination* (of soldiers).

**modō** [abl. of **modus**], adv., (*with measure?*), *only, merely, just, even, just now, lately*: **paulum modo** (*just, a very*); **non . . . modo** (*not only*); **aspectum modo** (*the mere sight*).

**modus**, -ī, [√MOD (cf. **moderor**) + **us**], M., *measure, quantity*. Hence, *manner, fashion, style*.

**moenia**, -ium, [√MI (*distribute?*) + **nis** (cf. **communis**) (orig. shares of work done by citizens?)], N. plur., *fortifications*.

**moestus**, see spelling **maestus**.

**mōlēs**, -is, [?, cf. **molestus**], F., *a mass*. — Esp., *a dike, a dam*.

**molestē** [old abl. of **molestus**], adv., *heavily, severely*: **molestē ferre** (*take hardly, be vexed at*).

**mōlimentum**, -ī, [**molī-** (stem of **molior**) + **mentum**], N., *trouble, difficulty*.

**molitus**, -a, -um, p.p. of **molo**.

**molliō**, -īvi, -itus, -ire, [**molli-**], 4. v. a., *soften*. — Fig., *make easy*: **clivum**.

**mollis**, -e, [?], adj., *soft, tender*. — Fig., *weak, feeble, not hard, not firm*: **animus ad resistendum**; **litus** (*gently sloping*).

**mollitiēs**, -ēi, [molli + ties (cf. -tia)], F., *softness*. — Fig., *weakness*: **animi** (*feebleness of purpose, want of persistence*).

**molō**, -uī, -itus, -ere, [?], 3. v. a., *grind*.

**mōmentum**, -ī, [movi- (as stem of **moveo**) + mentum], N., *means of motion, cause of motion*. — Fig., *weight, importance, influence*: **habere** (*be of importance*).

**Mona**, -ae, [Celtic], F., the Isle of Anglesey, off the coast of Britain.

**moneō**, -uī, -itus, -ēre, [causative of √MAN (in **memini**) or denominative fr. a kindred stem], 2. v. a., *remind, warn, advise, urge*.

**mōns**, montis, [√MAN (in **mineo**) + tis (reduced)], M., *a mountain*.

**mora**, -ae, [prob. root of **memor** + a], F., *delay, grounds of delay*.

**morātus**, -a, -um, p.p. of **moror**.

**morbus**, -ī, [√MAR (in **morior**) + bus (cf. **turba**)], M., *sickness, illness*.

**Morini**, -ōrum, [Celtic], M. plur., a tribe of the Belgæ on the coast of Picardy.

**morior**, mortuus (**moritūrus**), morī (**morirī**), [√MAR (cf. **mors**), but prob. in part denominative], 3. v. dep., *die*.

**Moritasgus**, -ī, [Celtic], M., a chief of the Senones.

**moror**, -ātus, -ārī, [mora-], 1. v. dep., *retard, hinder, check* (the advance of), *delay, wait, stay*.

**mors**, mortis, [√MAR + tis], F., *death*: **sibi mortem consciscere** (*commit suicide*).

**mortuus**, -a, -um, p.p. of **morior**.

**mōs**, mōris, [?], M., *a custom, a usage, a way* (of acting). — Plur., *customs, habits, character* (as con-

sisting of habits, cf. **Ingenium** and **indoles**, of native qualities).

**Mosa**, -ae, [Celtic], M., a river in Belgic Gaul, now the *Meuse*.

**mōtus**, -a, -um, p.p. of **moveo**.

**mōtus**, -tūs, [movi- (as stem of **moveo**) + tus], M., *a movement, a disturbance, an uprising*: **expeditior** (*movement of ships*); **celer atque instabilis** (*change, of the passage of events in maritime warfare*); **siderum** (*revolutions*).

**moveō**, mōvī, mōtus, movēre, [?, prob. denominative], 2. v. a., *set in motion, move, stir*: **castra** (*move from a place to another*; also, absolutely, *break camp*).

**mulctō**, see **multō**.

**mulier**, -eris, [?], F., *a woman*.

**mūliō**, -ōnis, [mulō + o], M., *a muleteer, a driver*.

**multātus**, -a, -um, p.p. of **multō**. **multitūdō**, -dinis, [multō + tūdo], F., *a great number, great numbers, number* (generally). — Esp., *the multitude, the common people*.

**multō**, see **multus**.

**multō**, -āvī, -ātus, -āre, [for **muleto**, freq. of **mulceo**, multa-], 1. v. a., *punish* (by fine), *deprive* (one of a thing as a punishment).

**multum**, see **multus**.

**multus**, -a, -um, [?, poss. root of **mille**, miles, + tus], adj., *much, many*: **multo die** (*late in the day*); **ad multam noctem** (*till late at night*). — **multum**, neut. as subst. and adv., *much*. — Also, plur., **multa**, *much*. — Abl., **multo**, *much, far*: **multo facilius**. — As compar.,

**plūs**, plūris, N. subst. and adv.; plur. as adj., *more, much, very*. — As superl., **plūrimus**, -a, -um, *most, very many, very much*: **quam plurimi** (*as many as possible*); **quam**

**plurimos possunt** (*the most they can*); **plurimum posse** (*have most power, be very strong or influential*); **plurimum valere** (*have very great weight*).

**mūlus**, -ī, [?], perh. akin to **molo**, *the mill-beast*, M., a mule.

**Mūnātius**, -ī, [prob. akin to **munus**], M., a Roman gentile name. — Esp., *Lucius Munatius Plancus*, a legatus in Cæsar's army.

**mundus**, -ī, [?], M. (orig. adj., *well ordered*, a translation of Gr. κόσμος), *the universe, the world*.

**mūnimentum**, -ī, [munī + mentum], N., a fortification. — Plur., a defence.

**mūniō**, -īvi (-īi), -ītus, -īre, [muni- (stem of **moenia**)], 4. v. a. and n., *fortify*. — Less exactly, *protect, defend, furnish* (by way of protection). — Esp. (prob. original meaning), *make* (by embankment): **castra; iter**.

**mūnitiō**, -ōnis, [munī + tio], F., *fortification* (abstractly). — Concretely, *a fortification, works, fortifications, defences*: **munitio operis** (*building works of defence*); **munitiois causa** (*to build works, etc.*).

**mūnitus**, -a, -um, p.p. of **munio**.

**mūnus**, -eris, [min (as if root of **moenia**) + us, orig. *share* (cf. **moenia**)], N., a duty, a service, a task. — Also, (*a contribution*), a tribute, a gift, a present.

**mūrālis**, -e, [murō + alis], adj., *of a wall, wall*: **pila** (heavy javelins for service in siege operations).

**mūrus**, -ī, [?], M., a wall (in itself considered, cf. **moenia, defences**).

**musculus**, -ī, [mus + culus, dimin.], M., (*little mouse*), a shed

(small, for covering besieging soldiers).

**mutilus**, -a, -um, [?], adj., *mutilated*: **cornibus** (*with short broken horns, of the elk*).

**mūtō**, -āvī, -ātus, -āre, [prob. same as **moto**, for †**movitō**-], I. v. a., *change, change for the better* (*remedy*).

## N.

**nactus**, -a, -um, p.p. of **nanciscor**.

**nam** [case-form of √NA, cf. **tam, quam**], conj., *for*.

**Nammējus**, -ī, [Celtic], M., a Helvetian sent as ambassador to Cæsar.

**Namnētes**, -um, [Celtic], M. pl., a Gallic tribe on the Loire around *Nantes*.

**namque** [nam-que], conj., *for* (a little more emphatic than **nam**).

**nanciscor**, **nactus** (**nactus**), -ciscī, [√NAC, cf. **nactus**], 3. v. dep., *find, get, procure, light upon, get hold of, obtain*.

**nactus**, -a, -um, p.p. of **nanciscor**.

**Nantuātes**, -um, [Celtic], M. pl., a tribe of Gaul of uncertain position, probably in Savoy.

**Narbō**, -ōnis, [Celtic], M., a city of the Roman province of Gaul, early made a Roman colony, now *Narbonne*.

**nāscor**, **nātus**, **nāscī**, [√GNA, cf. **gigno**], 3. v. dep., *be born, arise, be produced, spring up, be raised* (of beasts), *be found* (**plumbum**). — **nātus**, p.p., *sprung, born*.

**Nasua**, -ae, [Celtic], M., a nobleman of the Treviri.

**nātālis**, -e, [natu- (reduced) + alis], adj., of birth: dies (a birth-day).

**nātiō**, -ōnis, [√GNA + tio, perh. through intermediate stem], F., (a birth), a race, a nation, a tribe, a clan.

**nātīvus**, -a, -um, [natu- (reduced) + ivus], adj., native, natural.

**nātūra**, -ae, [natu + ra (F. of -rus)], F., (birth), nature (of living creature), character, nature (of inanimate things); ea rerum natura (such the state of the case); secundum naturam fluminis (down stream); natura triquetra (in form); natura cogebat (must necessarily); de rerum natura (physical science); eadem feminae marisque (form, organization); naturam vincere (human nature); natura loci (nature of the ground).

**nātus**, -tūs, [√GNA + tus], M., birth: majores natu (elders).

**nauta**, -ae, [perh. Gr. ναύτης], M., a sailor, a boatman.

**nauticus**, -a, -um, [nauta + cus], adj., of a sailor (or sailors), naval.

**nāvālis**, -e, [navi- (reduced) + alis], adj., of ships, naval.

**nāvicula**, -ae, [navi + cula], F., boat, small vessel.

**nāvigātiō**, -ōnis, [navigā + tio], F., a sailing, a voyage, travelling by sea, a trip (by sea).

**nāvigium**, -ī, [†navigō- (? , navi + †agus) + ium], N., a vessel (general), "a craft."

**nāvigō**, -āvī, -ātus, -āre, [†navigō- (see navigium)], I. v. n., sail.

**nāvis**, -is, [√(s)NU (increased), with added ī, cf. Gr. ναὺς], F., a ship, a vessel, a boat: oneraria (a transport); longa (a war galley); navi egredi (land).

**nāvō**, -āvī, -ātus, -āre, [(g)navō-], I. v. a., do one's best: operam (do one's best).

**nē** [√NA, unc. case-form], conj., lest, that . . . not, not to (do anything), from (doing anything), so that . . . not, for fear that. — After verbs of fearing, that: ne . . . quidem (not . . . even, not . . . either); ne Vorenus quidem (nor Vorenus either, Vorenus too did not, etc.).

**-ne** (enclitic) [prob. same as **nē**, orig. = **nonne**], conj., not? (as a question, cf. **nonne**), whether, did (as question in Eng.), do, etc. — See also **neque**, **nec** (see **neque**).

**nec**, see **neque**.

**necēssārius**, -a, -um, [†necessō- (reduced) + arius], adj., (closely bound?), necessary: tempus (critical); causa (pressing, unavoidable); res (absolutely necessary, needful, indispensable). — Also, as subst., a connection (a person bound by any tie), a close friend. — Abl. as adv., **necēssāriō**, of necessity, necessarily.

**necēsse** [?, ne-cessō], indecl. adj., necessary. — With **est**, one must, one cannot but, one must inevitably.

**necēssitās**, -tātis, [†necessō + tas], F., necessity (constraint, compulsion): temporis (exigency); suarum necessitatum causa (interests).

**necēssitudō**, -dinis, [†necessō + tudo], F., close connection (cf. **necessarius**), intimacy (close relations).

**necne** [nec ne], conj., or not (in double questions).

**necō**, -āvī (-uī), -ātus (-tus), -āre, [nec- (stem of **nex**)], I. v. a., put to death, kill, murder (in cold blood).

**necubī** [ne cubi (? , for **quobī**,

see **ubi**], conj., *that nowhere, lest anywhere, that not . . . anywhere.*

**nefārius**, -a, -um, [nefas + ius], adj., *wicked, infamous, abominable.*

**nefās** [ne-fas], N. indecl., *a crime* (against divine law).

**neglegō** (necl-), -lēxī, -lēctus, -legere, [nec (= ne) -lego], 3. v. a., *not regard, disregard, neglect: injurias* (leave unavenged, leave unpunished); *hac parte neglecta* (leave unnoticed); *metu mortis neglecto* (careless of, etc.).

**negō**, -āvī, -ātus, -āre, [?, poss. ne-aio], 1. v. a. and n., *say no, say . . . not, refuse.*

**negōtiōr**, -ātus, -ārī, [negotiō-], 1. v. dep., *do business* (on a large scale, as in money, etc.).

**negōtium**, -ī, [nec-otium], N., *business, occupation, an undertaking.* — Less definitely, *a matter, a thing.* — Also, *difficulty, trouble: in ipso negotio* (at the moment of action); *negotium conficere* (make a thorough business of a thing, finish a thing up); *quid negoti* (what business? cf. Eng. "what business have you here?"); *dare negotium alicui* (employ one, give in charge to).

**Nemētes**, -um, [Teutonic], M. pl., a German tribe on the Rhine.

**nēmō**, †nēminis, [ne-homo], C., *no one, nobody.*

**nēquāquam** [ne-quaquam (cf. eā, quā)], adv., *in no way, by no means.*

**neque** (nec) [ne-que], adv., *and not, nor: neque . . . neque* (neither . . . nor).

**nē . . . quidem**, see **ne**.

**nēquī(d)quam** (nēquic-), [ne . . . quī(d)quam], adv., *to no purpose, in vain, not without reason.*

**nēquis(-quī)**, -qua, -quid (-quod),

[ne-quis], pron., *that no, that nothing, lest any, etc.* (see **ne**).

**Nervicus**, -a, -um, [Nerviō- (reduced) + cus], adj., *of the Nervii, Nervian.*

**Nervius**, -a, -um, [Celtic], adj., *Nervian.*—Plur., **Nervii**, *the Nervii*, a powerful tribe of Belgic Gaul.

**nervus**, -ī, [prob. for †nevrus, cf. Gr. νεῦρον], M., *a sinew.*—Fig., in plur., *strength, vigor.*

**neuter**, -tra, -trum, [ne-uter], pron., *neither.*—Plur., *neither party, neither side.*

**nēve** (neu) [ne-ve], conj., *or not, and not, nor.*

**nex**, necis, [?], F., *death.*

**nihilum**, -ī (nihil), [ne-hilum?], N. and indecl., *nothing: nihil reliqui* (nothing left); *nihil respondere* (make no answer).—**nihilō**, abl. as adv., *none, no.*—**nihil**, acc. as adv., *not at all: nonnihil* (somewhat).

**nimis** [?], adv., *too, too much: non nimis* (not very).

**nimius**, -a, -um, [nimi- (? stem of nimis) + ius], adj., *too much, too great.*

**nisi** [ne-si], conj., (*not . . . if*), *unless, except: nisi si* (except in case, unless); *nisi cum* (until); *nisi rogatus* (without being asked).

**nīsus**, -a, -um, p.p. of **nitor**.

**Nitiobroges** (-briges), -um, [Celtic], M. plur., a tribe of Aquitania, on the Garonne.

**nitor**, nīsus, (nīxus), nīti, [prob. genu], 3. v. dep., (*strain with the knee against something*), *struggle, strive, exert one's self: niti insidiis* (rely upon).

**nīx**, nīvis, [?], F., *snow.*

**nōbilis**, -e, [as if (g)no (root of nosco) + bilis], adj., *famous, noble, well-born* (cf. "notable").

**nōbilitās**, -tātis, [nobili + tas], F., nobility. — Concretely, *the nobility, the nobles*.

**nocēns**, see **noceo**.

**noceō**, -uī, no p.p., nocēre, [akin to **nex**], 2. v. n., *do harm to, injure, harm, harass*. — **nocēns**, -entis, p.p. as adj., *hurtful, guilty* (of some harm).

**noctū** [abl. of †**noctus** (**noc** + **tus**)], as adv., *by night*.

**nocturnus**, -a, -um, [**noc** + **tur-** + **nus**, cf. **diuturnus**], adj., *of the night, nightly, nocturnal, in the night, by night*.

**nōdus**, -ī, [?], M., *a knot, a joint*: **nodi et articuli** (*protuberant joints*).

**nōlō**, nōluī, nōlle, [**ne**-**volo**], irr. v. a. and n., *not wish, be unwilling, wish not, not like to have*.

**nōmen**, -minis, [√(G)NO (root of **nosco**) + **men**], N., *a name* (what one is known by), *name* (fame, prestige). — As a name represents an account, *an account*: **nomine dotis** (*on account of, as*); **suo nomine** (*on his own account*); **nomine obsidum** (*under pretence of hostages*).

**nōminātim** [acc. of real or supposed †**nominatis** (**nominā** + **tis**)], adv., *by name* (individually).

**nōminō**, -āvi, -ātus, -āre, [**nomin-**], I. v. a., *name, mention, call by name*.

**nōn** [**ne**-**oenum** (**unum**)], adv., *not*: **non est dubium** (*there is no doubt*); **non mediocriter** (*in no small degree*).

**nōnāgintā**, indecl., *ninety*.

**nōndum** (see **dum**), *not yet*.

**nōnnihil** (see **nihil**), *something*.

**nōnnūllus** (see **nullus**), *some*.

**nōnnunquam**, *sometimes*.

**nōnus**, -a, -um, [†**novi** (?) + **nus** (**mus**)], adj., *ninth*.

**Nōrēja**, -ae, [Teutonic], F., a city of the Norici, in modern Styria.

**Nōricus**, -a, -um, [stem akin to **Noreja** + **cus**], adj., *of the Norici* (see **Noreja**).

**nōscō**, nōvī, nōtus, nōscere, [√(G)NA], 3. v. a., *learn, become acquainted with*. — In perfect tenses, *know*. — **nōtus**, -a, -um, p.p. as adj., *known, familiar, well-known*: **notis vadis** (*being acquainted with, etc.*).

**noster**, -tra, -trum, [prob. **nos** (plur. nom.) + **ter**], adj. pron., *our, ours*. — In plur., *our men* (the Romans), *our forces*.

**nōtitia**, -ae, [**notō** + **tia**], F., *acquaintance with*.

**novem** [unc. reduced case-form], ind. num. adj., *ne*.

**Noviodūnum**, -ī, [Celtic], N.: 1. A town of the Bituriges, on the Loire. — 2. A town of the Hædui. — 3. A town of the Suessiones.

**novitās**, -tātis, [**novō** + **tas**], F., *novelty, strangeness, strange character*: **rei** (*novelty, unexpected occurrence*).

**novus**, -a, -um, [?, cf. Eng. *new*], adj., *new, novel, fresh*: **res novae** (*a change of government, revolution*). — **novissimus**, -a, -um, sup., *latest, last*: **agmen** (*the rear*).

**nox**, noctis, [akin to **noceo**], F., *night*.

**noxia**, -ae, [√NOC (in **noceo**) + unc. term.], F., *crime, guilt*.

**nūbō**, nūpsī, nūptus, nūbere, [akin to **nubes**], 3. v. n., *veil one's self* (of the bride), *marry* (of the woman).

**nūdātus**, -a, -um, p.p. of **nudo**.

**nūdō**, -āvī, -ātus, -āre, [nūdō-], I. v. a., *lay bare, expose*. — Less exactly, *clear* (**murum defensoribus**).

**nūdus**, -a, -um, [?, root (akin to

naked) + dus], adj., *naked, bare, unprotected, exposed.*

**nūllus**, -a, -um, [ne-ullus], adj., *not any, no.* — **nōnnūllus**, *some.* — As subst., *some, some persons.*

**num** [pron. √NA, cf. **tum**], adv., interrog. part., suggesting a negative answer, *does, is, etc., it is not is it, and the like: num posse* (in indirect discourse, *could he, etc.*).

**nūmen**, -inis, [√NU (in **nuo**) + men], N., (*a nod*), *will, power.* Hence, *divinity.*

**numerus**, -ī, [†numo- (cf. **nummus**, **Numa**, Gr. *vómos*) + rus], M., *a number, number: in hostium numero habuit* (*in the place of, etc., euphemism for slaughtered*); *totidem numero* (*the same number*); *impedimentorum* (*quantity, i.e. number of pack-horses*); *ad numerum* (*to the required number*); *aliquo numero* (*of some account*).

**Numida**, -ae, [perh. Gr. *vóμαδα*, acc. of *vóμας*], M., *a Numidian* (employed in the Roman army as cavalry, cf. *Zouave, Turco*).

**nūmmus** (**nūmus**), -ī, [akin to **numerus**, Gr. *vóμος*], M., *a coin: pro nummo* (*for coin*).

**nunc** [num-*ce*, cf. **hic**], adv., *now* (emphatic, as an instantaneous *now*, cf. **jam**, unemphatic and continuous): *etiam nunc* (*even then, of the past considered as present*).

**nunquam** [ne-unquam], adv., *never.* — Also, **numquam**, cf. **unquam**.

**nūntiātus**, -a, -um, p.p. of **nuntio**.

**nūntiō**, -āvī, -ātus, -āre, [nuntiō], 1. v. a., *send news, report, make known: nuntiatum est ei, etc.; ne* (*he was ordered not to, etc.*).

**nūntius**, -ī, [†novent- (p. of †noveo, *be new*) + ius], M., (*new-*

*comer*), *a messenger.* Hence, *news: nuntium mittere* (*send word*); *per eorum nuntios* (*agents*).

**nūper** [for **novi-per**, cf. **parum per**], adv., *lately, recently, not long ago.*

**nusquam** [ne-usquam], adv., *nowhere, in no case* (almost equal *never*).

**nūtus**, -tūs, [√NU + tus], M., *a nod, a sign: ad nutum* (*at one's beck, at one's command*); **nutu** (*by signs*).

## O.

**ob** [unc. case-form akin to Gr. *ἐπί*], prep. (adv. in composition), (*near*), *against*. Hence, *on account of, for: ob eam rem* (*for this reason, on this account*). — In comp., *towards, to, against*.

**obaerātus**, -a, -um, [ob-†aeratus, as if p.p. of †aero], adj., *bound in debt* (to some one). — As subst., *a debtor, a servant for debt*.

**obducō**, -dūxī, -ductus, -ducere, [ob-duco], 3. v. a., *lead towards, lead against: fossam* (*throw out, in a military sense, carry along*).

**obeō**, -iī, -itus, -ire, [ob-eo], irr. v. a., *go to, go about, attend to*.

**obiciō**, -jēcī, -jectus, -icere, [objacio], 3. v. a., *throw against, throw in the way, throw up* (against the enemy, etc.), *set up, expose.* — **objectus**, -a, -um, p.p. as adj., *lying opposite, lying in the way*.

**obitus**, -tūs, [ob-itus], M., *a going to.* — Esp., *a going to death* (cf. **obire mortem**), *destruction, annihilation*.

**objectus**, -a, -um, p.p. of **obiciō**, see **obicio**.



**oblātus**, -a, -um, p.p. of **offero**.

**obliquē** [old abl. of **obliquus**], adv., *obliquely, slanting*.

**obliquus**, -a, -um, [ob-+liquus, cf. **limus**], adj., *slanting*.

**obliviscor**, -lītus, -līvīscī, [ob-+liviō, cf. **liveo**], 3. v. dep., (*grow dark against?*), *forget*.

**obsecrō**, -āvi, -ātus, -āre, [manufactured from **ob sacrum** (*near or by some sacred object*)], 1. v. a., *entreat, adjure*.

**obsequentia**, -ae, [obsequent + ia], F., *compliance*: **obsequentia nimia** (*too ready compliance*).

**observātus**, -a, -um, p.p. of **ob-servo**.

**observō**, -āvī, -ātus, -āre, [ob-servo], 1. v. a., (*be on the watch towards?*), *guard, maintain, keep*: **judicium (follow)**; **dies natales (keep, celebrate)**.

**obses**, -idis, [ob-+ses, cf. **praeses** and **obsidio**], C., (*a person under guard*), *a hostage*.

**obsessiō**, -ōnis, [ob-+sessio], F., *a blockade, a siege, a state of siege* (cf. **oppugnatio**, of actual siege operations).

**obsessus**, -a, -um, p.p. of **ob-sideo**.

**obsideō**, -sēdī, -sessus, -sidēre, [ob-sedeo], 2. v. a., (*sit down against*), *blockade, beset, guard*.

**obsidiō**, -ōnis, [obsidiō- (reduced) + o], F., *a siege* (cf. **obsessio**), *a blockade*. — Also, *the art of siege*.

**obsignātus**, -a, -um, p.p. of **ob-signo**.

**obsignō**, -āvī, -ātus, -āre, [ob-signo], 1. v. a., *seal up, seal*.

**ob-sistō**, -stitī, no p.p., -sistere, [ob-sisto], 3. v. n., *withstand*.

**obstinātē** [old abl. of **obstinatus**], adv., *persistently*.

**obstrictus**, -a, -um, p.p. of **obstringo**.

**obstringō**, -strinxī, -strictus, -stringere, [ob-stringo], 3. v. a., *bind* (lit. and fig.).

**obstructus**, -a, -um, p.p. of **obstruo**.

**obstruō**, -strūxī, -structus, -struere, [ob-struo], 3. v. a., *block up, barricade*.

**obtemperō**, -āvī, -ātūrus, -āre, [ob-tempero], 1. v. n., (*conform to*), *comply with, submit to*.

**obtestor**, -ātus, -ārī, [ob-testor], 1. v. dep., *implore* (*calling something to witness*).

**ob-tineō**, -tinuī, -tentus, -tinēre, [ob-teneo]. 2. v. a., *hold* (*against something or somebody*), *retain, maintain, occupy, possess*: **provinciam (have control of as praetor)**; **justissimam apud eum causam obtinere** (*be entirely free from obligation towards him, as having a perfect right to benefits conferred*).

**obtulī**, perf. of **offero**.

**obvenio**, -vēnī, -ventūrus, -venire, [ob-venio], 4. v. n., *come to, come in one's way, fall to one* (by lot).

**obviam** [ob-viam], adv., *in the way of, to meet* (any one): **obviam venire** (*come to meet*).

**occāsiō**, -ōnis, [ob-+casio, cf. **occido**], F., *opportunity*: **occasio brevis** (*a short time*).

**occāsus**, -sūs, [ob-casus, cf. **occido**], M., *a falling, a setting* (of the sun): **solis** (*the sunset, the west*).

**occidō**, -cidī, -cāsūrus, -cidere, [ob-cado], 3. v. n., *fall, set, be slain*: **sol occidens** (*the west*).

**occēdō**, -cidī, -cīsus, -cidere, [ob-

caedo], 3. v. a., *kill, massacre*: occisi (*the slain*).

occultātiō, -ōnis, [occulta + tio], F., *concealment*.

occultātus, -a, -um, p.p. of occultus.

occultē [old abl. of occultus], adv., *secretly*.

occultō, -āvi, -ātus, -āre, [occultō-], 1. v. a., *conceal, hide*.

occultus, -a, -um, [p.p. of occultus], as adj., *concealed*: in occulto (*in secret*); ex occulto (*from an ambush, in ambush*); in occulto sese continere (*keep themselves hidden*); insidiandi ex occulto (*of attacking from an ambush*).

occupātiō, -ōnis, [occupā + tio], F., *occupation* (engagement in business), *business, affairs* (of business): occupationes tantularum rerum (*engagement in such trifling matters*).

occupātus, -a, -um, p.p. of occupo.

occupō, -āvi, -ātus, -āre, [†occupō- or †occup- (cf. auceps), ob and stem akin to capio], 1. v. a., *seize, take possession of, seize upon, occupy* (only in military sense): regna (*usurp*); in opere occupati (*engaged*).

occurrō, -curri (-cucurri?), -cur-sūrus, -currere, [ob-curro], 3. v. n., *run to meet, meet, come upon, find, fall in with*: eo (*run, to meet an enemy*); ad animum (*occur*).

occursō, -āvi, no p.p., -āre, [occursō-, p.p. of occurro], 1. v. n., *rush* (to meet).

Oceanus, -i, [Gr. Ὠκεανός], M., *the ocean* (with or without *mare*).

Ocelum, -i, [Celtic], N., a town of the Graioceli in Cisalpine Gaul (*Oulx* in Piedmont).

ōciter [†ocu- (cf. Gr. ὠκός) + ter], adv., *swiftly*. — ōcius, compar., *swiftly*.

octāvus, -a, -um, [octo + vus (cf. Gr. ὀγδοῦσος?), poss. †octau + us], adj., *eighth*.

octingenti, -ae, -a, [stem akin to octo + centum], num. adj., *eight hundred*.

octō [?], num. adj., *eight*.

octōdecim [octo-decem], num. adj., *eighteen*.

Octodūrus, -i. [Celtic], M., a town of the Veragri, now *Martigny*.

octōgintā [octo + ?], adj., *eighty*.

octōni, -ae, -a, [octo + nus], adj., *eight at a time, eight* (at a time, implied in English).

oculus, -i, [†ocō + lus], M., *the eye*. sub oculis (*in sight, before the eyes*).

ōdi, ōdisse, [perf. of lost verb (with pres. sense), akin to odium], irr. v. a., *hate, detest*.

odium, -i, [√VADH (*spurn*) + ium], N., *hatred*.

offendō, -fendi, -fēnsus, -fendere, [ob-fendo], 3. v. a. and n., *dash against, hurt*: animum (*hurt the feelings, alienate, shock*). — Absolutely, *suffer a mishap*.

offēnsiō, -ōnis, [ob-†fensio, cf. defensio and offendere], F., *striking against*. — Fig., *offence*: sine offensione animi (*without wounding one's feelings*).

offerō, obtuli, oblātus, offerre, [ob-fero], irr. v. a., (*bring to*), *throw in one's way, offer*: se hostibus (*throw themselves upon*); quos sibi oblatos (*placed in his power*); beneficium (*confer, render*).

officium, -i, [ob-†facium, cf. beneficium], N., (*doing something to one*), *a service, performance of a*

*duty*. — Transf., a *duty, allegiance, an obligation*: *discedere ab officio* (*fail of one's duty*).

**Olovicō**, -ōnis, [Celtic], M., a king of the Nitiobriges.

**omittō**, -misi, -missus, -mittere, [ob-mitto], 3. v. a., *let go by*: *consilium* (*leave untried*); *omnibus omissis rebus* (*leaving everything else*).

**omniñō** [abl. of †*omnis* (*omni + nus*)], adv., *altogether, entirely, only, utterly, in all, at all, any way, only just, whatever* (with negatives).

**omnis**, -e, [?], adj., *all, the whole* of (as divisible or divided, cf. *totus* as indivisible or not divided). — In sing., *every* (without emphasis on the individuals, cf. *quisque*, *each*, emphatically); *celerius omni opinione* (*of any one*); *omni tempore* (*on all occasions, always*); *omnes preces* (*every form of prayers*); *omnibus rebus* (*everything, everything else*); *per omnia*, etc. (*through nothing but, etc.*). — In plur. as a short expression for, *all others*.

**onerarius**, -a, -um, [oner- (as stem of *onus*) + *arius*], adj., *for burdens*: *naves* (*transports*).

**onerō**, -avi, -atus, -are, [oner- (as stem of *onus*)], 1. v. a., *load*: *celeritas onerandi* (*of ships, facility of loading*).

**onus**, -eris, [unc. root + *us*], N., *a burden, a load, a freight, a cargo*. — Abstr., *weight*. — Esp.: *tanta onera navium* (*ships of such weight*).

**opera**, -ae, [oper- (as stem of *opus*) + a (F. of *-us*)], F., *work, pains, attention*: *operam navare* (*do one's best*); *operam dare* (*devote one's self, exert one's self, take pains*). — With *ut*, *try, take care*: *opera uti* (*services, help, etc.*); *quo-*

*rum opera interfectus* (*through whose means, agency*).

**opiniō**, -ōnis, [opinō- (cf. *nec-opinus*) + o], F., *notion, expectation*: *celerius omni opinione* (*quicker than any one would suppose*); *opinio virtutis* (*reputation for, etc.*); *tanta opinio hujus belli* (*impression*); *tantum opinionem timoris praebuit* (*gave such an idea, impression*); also, *opinio timoris* (*display, cause for an impression*); *speciem atque opinionem pugnantium praebere* (*make a show and give an impression of being combatants*); *nomen atque opinio* (*reputation*); *ut fert illorum opinio* (*as their notion is*); *ad opinionem Galliae* (*for an impression on the Gauls*); *opinionem praecipere* (*to anticipate*).

**oportet**, -uit, no p.p., -ēre, [noun-stem from *ob* and stem akin to *porto*, cf. *opportunus*], 2. v. imp., *it behooves, it ought*: *poenam sequi* (*the punishment was to follow*); *frumentum metiri* (*he ought, etc.*); *alio tempore atque oportuit* (*than it should have been*).

**oppidānus**, -a, -um, [oppidō- (reduced) + *anus*], adj., *of a (the) town*. — Plur. as subst., *the townspeople*.

**oppidum**, -i, [ob-†*pedum* (a plain?, cf. Gr. *πέδον*)], N., (the fortified place which, according to ancient usage, commanded the territories of a little state), *a stronghold, a town* (usually fortified).

**oppōnō**, -posui, -positus, -pōnere, [ob-pono], 3. v. a., *set against, oppose* (something to something else): *novem oppositis legionibus* (*with nine legions opposed to the enemy*). — **oppositus**, -a, -um, p.p. as adj., *opposed, lying in the way, opposite*.

**opportūnē** [old abl. of **opportunus**], adv., *opportunately*.

**opportunitās, -tātis**, [oppo-  
tunō + tas], F., *timeliness, fitness*  
(of time or circumstance), *good luck*  
(in time or circumstance), *conven-  
ience* (of a means of fortification).

**opportūnus, -a, -um**, [ob-portu-  
nus, cf. **importunus**, and **Portu-  
nus**], adj., (*coming to harbor?*), *op-  
portune, advantageous, lucky*.

**oppositus, -a, -um**, p.p. of **op-  
pono**.

**oppressus, -a, -um**, p.p. of **op-  
primo**.

**opprimō, -pressī, -pressus, -pri-  
mere**, [ob-premo], 3. v. a., (*press  
against*), *overwhelm, crush, over-  
power, overtake (surprise)*.

**oppugnātiō, -ōnis**, [oppugnā +  
tio], F., *a siege* (of actual operations,  
cf. **obsidio**, *blockade*), *besieging, an  
attack* (in a formal manner against a  
defended position).

**oppugnō, -āvi, -ātus, -āre**, [ob-  
pugno], 1. v. a., *attack* (formally,  
but without blockade), *lay siege to,  
carry on a siege, assail* (a defended  
position).

**ops, opis**, [?], F., *help, aid*. —  
Plur., *resources*. — Also, *help* (of sev-  
eral gods).

**optātus, -a, -um**, [p.p. of **opto**  
(*wish*)], as adj., *desired, desirable,  
wished for*.

**optimē**, see **bene**.

**optimus, -a, -um**, [op (cf. **ops**)?  
+ **timus** (cf. **finitimus**)], superl. of  
**bonus**.

**opus, operis**, [√OP + us], N.,  
*work, labor* (as accomplishing its  
purpose, cf. **labor**, as tiresome). —  
In military sense, *a work, works, for-  
tifications*: *natura et opere muni-  
tus* (*by nature and art*); *operum*

*atque artificiorum* (*trades, handi-  
crafts*). — In abl., **quanto-(tanto-)  
opere**, *how much, so much, so*:  
**magnopere** (*very much, very*).

**opus** [same word as preceding],  
N. indecl., *need, necessity*: **si quid  
ipsi a Caesare opus esset** (*if he  
needed anything of Cæsar*); **si quid  
opus facto**, etc. (*if anything needs  
to be done*).

**ōra, -ae**, [?], F., *a shore, a coast*.

**ōrātiō, -ōnis**, [orā + tio], F.,  
*speech, words, talk, address, dis-  
course, argument*.

**ōrātor, -tōris**, [orā + tor], M., *a  
speaker, an ambassador*.

**orbis, -is**, [?], M., *a circle* (a cir-  
cular plane): **orbis terrarum** (*the  
circle of lands, the whole world*). —  
Less exactly, *a hollow square* (in  
military language).

**Orcynia, -ae**, [Teutonic], F.,  
(with **silva**), *the Hercynian forest*  
(a vast extent of forest in the interior  
of Europe, see VI. 25).

**ordō, -inis**, [akin to **ordior**], M.,  
*a series, a row, a tier, a rank* (of  
soldiers), *a grade* (of centurions, as  
commanding special ordines of sol-  
diers, also the *centurions* themselves),  
*an arrangement, an order*: **nullo  
certo ordine** (*with no fixed order*);  
**perturbatis ordinibus** (*the ranks  
being broken*); **ratio ordoque ag-  
minis** (*the plan and arrangement  
of the march*); **ordines servare** (*to  
keep their places*, of soldiers, also of  
anything laid in rows or tiers, *pre-  
serve the arrangement, not deviating  
from it*).

**Orgetorix, -igis**, [Celtic, cf. **Dum-  
norix**, etc.], M., *a nobleman of the  
Helvetii*.

**orior, ortus, orīri**, [?], 3. (and 4.)  
v. n., *arise, spring up*: **orta luce**

(at daybreak). — Fig., *begin, start, spring from, arise, be started, have its source.* — **oriēns**, -entis, *p.* as adj., *rising: sol (sunrise, the east).*

**ornāmentum**, -ī, [ornā + mentum], *N.*, *an adornment.* — Fig., *an honor* (an addition to one's dignity), *a source of dignity.*

**ornātus**, -a, -um, *p.p.* of **orno**.

**ornō**, -āvi, -ātus, -āre, [unc. noun-stem], *I. v. a.*, *adorn, equip, furnish.* — Fig., *honor.* — **ornātus**, -a, -um, *p.p.* as adj., *furnished, well-equipped, honored.*

**ōrō**, -āvi, -ātus, -āre, [or- (as stem of os)], *I. v. a.* and *n.*, *speak.* — Esp., *pray, entreat.*

**ortus**, -a, -um, *p.p.* of **orior**.

**ortus**, -tūs, [√OR (in orior) + tus], *M.*, *a rising: solis (sunrise, the East).*

**ōs**, **ōris**, [?], *N.*, *the mouth, the face: ora convertere (turn the eyes).*

**Osismī**, -ōrum, [Celtic], *M. plur.*, *a people of Gaul (in Brittany).*

**ostendō**, -tendī, -tentus, -tendere, [obs-tendo], *3. v. a.*, *(stretch towards), present, show, point out, make known, state, declare: copias (discover, unmask).*

**ostentātiō**, -ōnis, [ostenta + tio], *F.*, *a showing, a display: ostentationis causa (for display); ostentationem comminuere (humble the pride).*

**ostentō**, -āvi, -ātus, -āre, [ostentō-], *I. v. a.*, *display, exhibit.*

**ōtium**, -ī, [?], *N.*, *repose, inactivity, quiet* (free from disturbance).

**ōvum**, -ī, [perh. avi + um], *(belonging to a bird?)*, *N.*, *an egg.*

## P.

**pābulātiō**, -ōnis, [pabulā + tio], *F.*, *a foraging: pabulationis causa (for foraging).*

**pābulātor**, -tōris, [pabulā + tor], *M.*, *a forager.*

**pābulor**, -ātus, -āri, [pabulō-], *I. v. dep.*, *forage* (gather fodder).

**pābulum**, -ī, [√PA (in pasco) + bulum (but prob. through †pabus or the like)], *N.*, *fodder* (for animals, including the stalk as well as the grain), *green fodder.*

**pācātus**, -a, -um, *p.p.* of **paco**.

**pācō**, -āvi, -ātus, -āre, [pac- (in pax)], *I. v. a.*, *pacify, subdue.* — **pācātus**, -a, -um, *p.p.* as adj., *peaceable, quiet, subject* (as reduced to peace): *insigne pacatum [-orum] (a token of submission).*

**pacum**, -ī, [p.p. of paciscor, pango?], *N.*, *(a thing agreed), an agreement, an arrangement.* Hence, *a method, a way* (of doing anything): *quo pacto (how).*

**Padus**, -ī, [Celtic], *M.*, *the Po*, the great river of Northern Italy (Cisalpine Gaul).

**Paemāni**, -ōrum, [Celtic], *M. pl.*, *a people of the Belgians.*

**paene** [?], *adv.*, *almost, nearly.*

**paenitet** (**poenitet**), -uit, -ēre, [†poenitō- (perh. p.p. of verb akin to punio)], *2. v. a.* (impers.), *it repents* (one), *one repents, one regrets.*

**pāgus**, -ī, [√PAG (in pango) + us (with unc. conn. of ideas)], *M.*, *a district, a canton* (cf. vicus, a smaller collection of dwellings).

**palam** [unc. case-form, cf. clam], *adv.*, *openly, publicly, without concealment.*

**palma**, -ae, [borrowed fr. Gr. παλάμη], *F.*, *the palm* (of the hand).

**palūs**, -ūdis, [?], F., a marsh.

**palūster**, -tris, -tre, [palud + tris], adj., *marshy*.

**pandō**, pandi, passus, pandere, [akin to **pandus**], 3. v. a., *spread out* (perh. orig. of the hands, bending back the wrist): **passis manibus** (*with outstretched hands*); **passis capillis** (*with dishevelled hair*).

**pār**, paris, [perh. akin to **paro**, **pario** (through the idea of barter or exchange)], adj., *equal, alike, like*: **intervallum** (*the same*). — Esp., *equal in power, a match for*.

**parātus**, -a, -um, p.p. of **paro**.

**parcē** [old abl. of **parcus**], adv., *sparsingly, frugally*.

**parcō**, peperi (parsī), parsūrus (parciturus), parcere, [akin to **parcus** (√PAR + cus, *acquisitive*, and so *frugal*?)], 3. v. n., *spare*. — Esp., *save alive*: **parcendo** (*by economy, by frugality*).

**parēns**, -entis, [√PAR (in **pario**) + ens (cf. Gr. *τεκών*)], C., a *parent*.

**parentō**, -āvi, -ātus, -āre, [parent-], 1. v. n., *make a funereal offering* (to deceased relatives, esp. parents). Hence, *avenge* (making an offering of the wrong-doer).

**pārēō**, pārui, pārītūrus, pārēre, [parō- (cf. **opiparus**)], 2. v. n., *be prepared, appear, obey*.

**pariō**, peperi, partus (paritūrus), parere, [√PAR, *procure* (perh. orig. by barter, cf. **par**)], 3. v. a., *procure, acquire, secure*.

**Parisiī**, -ōrum, [Celtic], M. plur., a Celtic tribe around modern Paris, whose town Lutetia takes its modern name from them, cf. *Rheims* (Remi), *Treves* (Treveri).

**parō**, -āvi, -ātus, -āre, [parō-, cf. **opiparus**, and **pareo**], 1. v. a., *pro-*

*cure, provide, prepare, get ready for* (bellum used concretely for the means of war), *arrange*. — **parātus**, -a, -um, p.p. as adj., *ready, prepared*: **animo parato** (with mind resolved, *resolute, determined*): **paratus in armis** (*armed for war*).

**pars**, partis, [√PAR + tis (reduced), akin to **portio**, and perh. to **par** through idea of barter], F., (*a dividing*), a *portion, a part, a share*. — Often of position or direction merely, *side, direction, region*: **una ex parte** (*on one side*); **in utram partem** (*in which direction*); **ex utraque parte** (*on both sides*); **sinistra pars** (*the left flank*); **pars fluminis** (*bank*); **major pars** (*the majority*). — Fig.: **qua ex parte** (*in which respect*); **omnibus partibus** (*in all respects*); **in utramque partem** (*in both respects, both ways, of a plan*); **in utramque partem** (*on both sides, of a discussion*). — Esp.: **tres partes** (*three quarters, three parts out of four*); **ex parte** (*in part*); **ad inferiorem partem fluminis** (*down the river*); **ab inferiore parte fluminis** (*further down, etc.*). — **partim**, acc. as adv., *in part, some . . . others*.

**partim**, see **pars**.

**partior**, -itus, -irī, [parti-], 4. v. dep., *divide*: **partitis temporibus** (*alternately*).

**partītus**, -a, -um, p.p. of **partior**.

**partus**, -a, -um, p.p. of **pario**.

**parum** [akin to **parvus**, perh. for **parvum**], adv., *not very, not much, not sufficiently*: **parum diligenter** (*too carelessly*).

**parvulus**, -a, -um, [parvō + lus], adj., *small, slight, insignificant*: **ab parvulis** (*from infancy*).

**parvus**, -a, -um, [perh. for **pau-**  
**rus**, cf. **paucus**, and Gr. *παῖπος*],  
adj., *small, slight, little*.

**passim** [acc. of †**passis** (**pad** +  
**tis**)], adv., *in all directions, all about*.

**passus**, -a, -um, p.p. of **pando**.

**passus**, -a, -um, p.p. of **patior**.

**passus**, -sūs, [√**PAD** (in **pando**)  
+ **tus**], M., (*a spreading of the legs*),  
*a stride, a step, a pace* (esp. as a  
measure, about five Roman feet):  
**mille passuum** (a Roman *mile*, five  
thousand feet).

**patēfaciō**, -fēcī, -factus, -facere,  
[noun-stem akin to **pateo** + **facio**],  
3. v. a., *lay open, open*.

**patēfactus**, -a, -um, p.p. of **pa-**  
**tēfacio**.

**patēfiō**, pass. of **patefacio**.

**pateō**, -uī, no p.p., -ēre, [†**patō-**  
(noun-stem akin to Gr. *περὶστυμαί*)],  
2. v. n., *be extended, lie open, spread,*  
*extend, be wide, be open*. — **patēns**,  
-entis, p. as adj., *open, exposed*.

**pater**, -tris, [√**PA** (in **pasco**?) +  
**ter**], M., *a father*. — Plur., *ancestors*.

**patienter** [**patient** + **ter**], adv.,  
*patiently*.

**patientia**, -ae, [**patient** + **ia**],  
F., *patience, endurance, forbearance*  
(in refraining from fighting).

**patior**, **passus**, **patī**, [?], 3. v. dep.,  
*suffer, endure, allow, permit*: **vim**  
**tempestatis** (*endure, stand*).

**patrius**, -a, -um, [**pater** + **ius**],  
adj., *of a father, ancestral, of one's*  
*fathers*.

**patrōnus**, -ī, [†**patrō-** (as if stem  
of †**patroo**, cf. **colōnus**, **agrōtus**)  
+ **nus**], M., *a patron, a protector*.

**patruus**, -ī, [**pat(e)r** + **vus**?], M.,  
*an uncle* (on the father's side, cf.  
**avunculus**, on the mother's).

**paucitās**, -tātis, [**paucō** + **tas**],  
F., *small number*.

**paucus**, -a, -um, [√**PAU**- (cf. **pau-**  
**lus** and **parvus**) + **cus**], adj., al-  
most always in plur., *few, some few*  
(but with implied *only* in a semi-  
negative sense): **paucis** (**pauca**) **re-**  
**spondit** (*in a few words, briefly*).

**paulātim** [**paulō-** (reduced) +  
**atim**, as if acc. of †**paulatis** (†**paulā**  
+ **tis**)], adv., *little by little, a little*  
*at a time, gradually*.

**paulisper** [**paulis** (abl. plur. of  
**paulus**?) **per**], adv., *a little while*.

**paulō** [abl. of **paulus**], as adv.,  
*a little, slightly*.

**paululum** [acc. of **paululus**],  
as adv., *a very little*.

**paulum** [acc. of **paulus** (√**PAU**  
+ **lus**, cf. **paucus**)], as adv., *a little,*  
*a short distance*.

**pāx**, **pācis**, [√**PAC**, as stem], F.,  
(*a treaty?*), *peace*.

**peccō**, -āvī, -ātūrus, -āre, [?],  
I. v. n., *go wrong, commit a fault*.

**Pectones**, see **Pictones**.

**pectus**, -oris, [perh. **pect** (as root  
of **pecto**) + **us**, from the rounded  
shape of the breast, cf. **pectinatus**],  
N., *the breast*.

**pecūnia**, -ae, [†**pecunō-** (**pecu** +  
**nus**, cf. **Vacuna**) + **ia**], F., *money*  
(originally cattle), *wealth*.

**pecus**, -oris, [√**PEC** (*tie?*) + **us**],  
N., *cattle* (especially sheep and  
goats): **pecore vivere** (*flesh of*  
*cattle*). — Pl., *cattle, flocks and herds*.

**pedālis**, -e, [**ped** + **alis**], adj., *of*  
*a foot* (in thickness), *a foot thick*.

**pedes**, -itis, [**ped** (as if **pedi**) +  
**tis** (reduced)], C., *a footman, a foot-*  
*soldier*. — Collectively, *the infantry*.

**pedester**, -tris, -tre, [**pedit** + **tris**],  
adj., *of infantry, of persons on foot*:  
**itinera** (*journeys on foot, marches,*  
*land routes*); **copiae** (*the foot, the*  
*infantry*).

**peditātus**, -tūs, [pedit + atus, cf. **consulatus**], M., *foot, infantry*.

**Pedius**, -ī, [?], M., a Roman gentile name. — Esp., *Quintus Pedius*, a nephew of Cæsar and a legatus under him in Gaul. He sided with Augustus, and was afterwards made consul by Augustus's patronage.

**pējor**, see **malus**.

**pējus**, see **malus**.

**pellis**, -is, [?], F., a *hide, a skin* (either on or off the body of an animal): **sub pellibus** (*in tents, i.e. in the field*).

**pellō**, pepulī, pulsus, pellere, [?], 3. v. a., *strike, beat, drive, defeat, repulse*.

**pendō**, pependī, pēnsus, pendere, [?], 3. v. a., *hang, weigh, weigh out*. Hence (since money was earlier weighed, not counted), *pay, pay out*. — Esp. with words of punishment, *pay* (a penalty), *suffer* (punishment, cf. **dare** and **capere**).

**penes** [prob. acc. of stem in -os akin to **penitus**], prep., *in the power of*.

**penitus** [stem akin to **penes**, **penus**, etc., + itus, cf. **antiquitus**], adv., *far within, deeply, entirely, utterly*: **penitus ad externos fines** (*clear to, all the way to*).

**penna**, see **pinna**.

**1. per** [unc. case-form of stem akin to Gr. *περί*], adv. (in composition) and prep., *through*. — Fig., *through, by means of* (cf. **ab**, *by, directly*), *by the agency of*. — Often accompanied by the idea of hindrance: **per anni tempus potuit** (*the time of the year would allow*); **per te licere** (*you do not prevent, you allow*); **per aetatem non poterant** (*on account of*). — Often in adv. expressions): **per fidem** (*in*

*good faith*, in consequence of a deception on the other side); **per concilium** (*in council*); **per insidias** (*treacherously*); **per cruciatum** (*with torture*); **per vim** (*forcibly*); **ipse per se** (*in and of itself*).

**2. per** [prob. a different case of same stem as **1. per**], adv. in comp., *very, exceedingly*.

**perāctus**, -a, -um, p.p. of **perago**. **peragō**, -ēgī, -āctus, -agere, [1. **perago**], 3. v. a., *conduct through, finish, accomplish*: **concilium** (*hold to the end*); **conventus** (*finish holding*).

**perangustus**, -a, -um, [2. **perangustus**], adj., *very narrow*.

**perceptus**, -a, -um, p.p. of **percipio**.

**percipiō**, -cēpī, -ceptus, -cipere, [1. **per-cipio**], 3. v. a., *take in* (completely), *learn, acquire, hear*. — Esp. of harvests, *gather*. Hence, fig., *reap*: **fructus victoriae**.

**percontātiō**, -ōnis, [percontā + tio], F., *inquiry, inquiries* (though sing. in Latin).

**percurrō**, -cucurrī (-currī), -cur-sus, -currere, [1. **per-curro**], 3. v. n. and a., *run along*.

**percussus**, -a, -um, p.p. of **percutio**.

**percutiō**, -cussi, -cussus, -cutere, [1. **per-quatio**], 3. v. a., *hit, strike, run through*.

**perdiscō**, -didicī, no p.p., -discere, [1. **per-disco**], 3. v. a., *learn thoroughly, get by heart*.

**perditus**, -a, -um, p.p. of **perdo**.

**perdō**, perdidī, perditus, perdere, [1. **per-do**], 3. v. a., *destroy* (cf. **interficio**), *ruin*. — **perditus**, -a, -um, p.p. as adj., *ruined, desperate, abandoned*.

**perducō**, -dūxī, -ductus, -ducere,



[1. **per-duco**], 3. v. a., *lead through, lead along, bring over, carry along* (fossam), *march* (legionem). — Fig., *prolong, win over, bring*: rem ad extremum casum (*reduce*).

**perductus**, -a, -um, p.p. of **perduco**.

**perendinus**, -a, -um, [perendie (†peren-die, cf. **postridie**) + inus], adj., (*of the day beyond*, cf. **per** and Gr. *πέρας*), *of day after to-morrow*: **perendino die** (*day after to-morrow, in two days*).

**pereō**, -ii(-ivī), -itūrus, -īre, [1. **per-eo**], irr. v. n., *perish, be killed* (in battle).

**perequitō**, -āvi, -ātus, -āre, [1. **per-equito**], 1. v. a. and n., *ride over* (or *around*).

**perexiguus**, -a, -um, [2. **per-exiguus**], adj., *very small*.

**perfacilis**, -e, [2. **per-facilis**], adj., *very easy*.

**perfectus**, -a, -um, p.p. of **perficio**.

**perferō**, -tulī, -lātus, -ferre, [1. **per-fero**], irr. v. a., *carry through* (or *over*); *opinionem* (*spread among*); *consilium* (*carry over*); *famam* (*bring*). — Also, *bear through* (to the end), *endure, suffer, submit to*.

**perficiō**, -feci, -fectus, -ficere, [1. **per-facio**], 3. v. a., *accomplish, complete, finish, make* (complete). — With **ut** (**uti**), *succeed* (in doing or having done).

**perfidia**, -ae, [perfidō + ia], F., *perfidy, treachery, faithlessness*.

**perfidus**, -a, -um, [1. **per** (or **perh.** a third case-form of same stem) -fidus], adj., *perfidious*.

**perfringō**, -frēgi, -fractus, -fringere, [1. **per-frango**], 3. v. a., *break through*.

**perfuga**, -ae, [1. **per-†fuga**

(√FUG + a, cf. **scriba**)], M., *a refugee, a fugitive, a deserter*.

**perfugiō**, -fūgi, no p.p., -fugere, [1. **per-fugio**], 3. v. n., *run away, flee* (to a place), *escape to*.

**perfugium**, -ī, [1. **per-†fugium**, cf. **refugium**], N., *a place of refuge, refuge*.

**pergō**, perrexi, perrectus(?), pergere, [1. **per-rego**], 3. v. n., (*keep one's direction?*), *keep on, continue to advance, advance*.

**periclitor**, -ātus, -ārī, [†periclitō (as if p.p. of **periculator**)], 1. v. dep., *try, make a trial, be exposed, be put in peril*.

**periculum**, see **periculum**.

**periculōsus**, -a, -um, [periculō + osus], adj., *dangerous*.

**periculum** (-clum), -ī, [†peri- (cf. **experior**) + culum], N., *a trial*. Hence, *peril, danger*.

**peritus**, -a, -um, [†peri- (cf. **experior**) + tus], p.p. as adj., (*tried*), *experienced, skilled, skilful*.

**perlātus**, -a, -um, p.p. of **perfero**.

**perlēctus**, -a, -um, p.p. of **perlego**. **perlegō**, -lēgi, -lēctus, -legere, [1. **per-lego**], 3. v. a., *read through, read* (a letter aloud).

**perluō**, -luī, -lūtus, -luere, [1. **per-luo**], 3. v. a., *wash all over*. — Pass. (as middle), *bathe*.

**permāgnus**, -a, -um, [2. **per-magnus**], adj., *very great, very large*.

**permaneō**, -mānsi, -mānsūrus, -manēre, [1. **per-maneo**], 2. v. n., *remain* (to the end), *continue, hold out, persist*: *in eadem libertate* (*continue to live, etc.*).

**permisceō**, -miscui, -mixtus (-mixtus), -miscere, [1. **per-misceo**], 2. v. a., *mix* (thoroughly), *mingle*.

**permissus**, -a, -um, p.p. of **permitto**.

**permittō**, -mīsī, -missus, -mittere, [1. per-mitto], 3. v. a., (*give over*), *grant, allow, give up, entrust: fortunatus (trust); summam imperi (place in the hands of, etc.); suffragiis rem (leave the matter to, etc.)*.

**permixtus**, -a, -um, p.p. of **permisceo**.

**permoneō**, -uī, -itus, -ēre, [1. permoneo], 2. v. a., *warn* (doubtful reading in VII. 38).

**permōtus**, -a, -um, p.p. of **permoveo**.

**permoveō**, -mōvī, -mōtus, -movēre, [1. per-moveo], 2. v. a., *move* (thoroughly), *influence, affect*. — **permōtus**, -a, -um, p.p., *much affected, much influenced, overcome*.

**permulceō**, -mulsī, -mulsus, -mulcēre, [1. per-mulceo], 2. v. a., *smooth over*. Hence, *soothe, pacify*.

**perniciēs**, -ēī, [?, akin to **nex**], F., *destruction, ruin*.

**perpaucus**, -a, -um, [2. per-paucus], adj. Plur., *very few, but very few, only a very few*.

**perpendiculum**, -ī, [perpendi- (stem of **perpendo**, *hang down*) + **culum**], N., *a plumb line: ad perpendiculum (perpendicular)*.

**perpetior**, -pessus, -petī, [1. per-patior], 3. v. dep., *suffer, endure*.

**perpetuus**, -a, -um, [1. perpetuus (√PET + vus)], adj., (*keeping on through*), *continuing, continuing, continuous, without interruption, lasting, permanent: vita (whole); paludes (continuous); in perpetuum (forever, permanently)*. — Abl. as adv., **perpetuō** (*for ever, constantly*).

**perquirō**, -quisivī, -quisitus, -quīrere, [1. per-quaero], 3. v. a., *search for, inquire about*.

**perrumpō**, -rūpī, -ruptus, -rumpere, [1. per-rumpo], 3. v. a. and n., *break through, force one's way through, break, force a passage*.

**perruptus**, -a, -um, p.p. of **perrumpo**.

**perscribō**, -scripsī, -scriptus, -scribere, [1. per-scribo], 3. v. a., *write out* (in full).

**persequor**, -secūtus, -sequī, [1. persequor], 3. v. dep., *follow up, pursue: mortem (avenge)*.

**perseverō**, -āvī, -ātūrus, -āre, [perseverō-], 1. v. n., *persist*.

**persolvō**, -solvī, -solūtus, -solvere, [1. per-solvo], 3. v. a., *pay* (fully). — Esp. (cf. **pendo**) of penalties, *pay, suffer* (punishment).

**perspectus**, -a, -um, p.p. of **perspicio**.

**perspicō**, -spēxī, -spectus, -spicere, [1. per-†specio], 3. v. a., *see through, see, inspect, examine*. — Also, *see thoroughly*. — Fig., *see clearly, see, understand, learn, observe, find, discover*.

**perstō**, -stitī, -stātūrus, -stāre, [1. per-sto], 1. v. n., *persist, remain firm, be firm*.

**persuādeō**, -suāsī, -suāsus, -suādēre, [1. per-suadeo], 2. v. a. and n., *induce, persuade: hoc volunt persuadere (make people believe)*. — Pass. (impers.), *be persuaded* (dat. of person), *be satisfied, believe*.

**perterreō**, -terruī, -territus, -terrēre, [1. per-terreo], 2. v. a., *terrify, alarm: perterritus equitatus (put in a panic); timore perterritus (struck with terror); quos perterritos (panic-stricken, flying in terror)*.

**pertimēscō**, -timuī, no p.p., -timēscere, [1. per-timē + sco], 3. v. a. and n., *fear much, fear greatly*.

**pertinācia**, -ae, [pertinac + ia], F., *obstinacy*.

**pertineō**, -tinūī, no p.p., -tinēre, [1. per-teneo], 3. v. n., (*hold a course towards*), *tend, extend*. — Fig., *have to do with, tend*: *eodem illo ut*, etc. (*have the same purpose, look in the same direction*); *res ad plures pertinet* (*more are implicated in*, etc.).

**pertulī**, see *perfero*.

**perturbātiō**, -ōnis, [perturbā + tio], F., *disturbance, alarm, panic*.

**perturbātus**, -a, -um, p.p. of *perturbo*.

**perturbō**, -āvī, -ātus, -āre, [1. per-turbo], 1. v. a., *disturb, throw into confusion, confuse, throw into disorder, alarm, terrify*.

**pervagor**, -ātus, -ārī, [1. per-vagor], 1. v. dep., *roam, scatter*.

**pervenio**, -vēnī, -ventus, -venire, [1. per-venio], 4. v. n., (*come through to*), *arrive at, get as far as, reach, come*. — Fig., *arrive*: *ad hunc locum* (*come to this point*); *pars* (of property, *come, fall*).

**perventus**, -a, -um, p.p. of *pervenio*.

**pēs**, pedis, [√PAD as stem], M., *the foot*. — Also, as a measure, *a foot*. — Esp.: *pedem referre* (*draw back, retreat*); *pedibus proeliari* (*on foot*); *ad pedes desilire* (*to the ground, from on horseback*, etc.); *pedibus aditus* (*approach by land*).

**petō**, petīvī, petitus, petere, [√PAT], 3. v. a. and n., (*fall?, fly?*), *aim at, attack, make for, try to get, seek, go to get, go to*. Hence, *ask, request, look for, get*: *petentibus Haeduis* (*at the request of*, etc.); *fugam* (*take to*).

**Petrocorī**, -ōrum, [Celtic], M. pl., a tribe on the Garonne (*Perigord*).

**Petrōnius**, -ī, [?], M., a Roman gentile name. — Esp., *Marcus Petronius*, a centurion in Caesar's army.

**Petrosidius**, -ī, [?], M., a Roman gentile name. — Esp., *Lucius Petrosidius*, a standard-bearer in Caesar's army.

**phalanx**, -angis, [Gr. φάλαγξ], F., a *phalanx* (properly an arrangement of troops in a solid mass from eight to twenty-four deep, but applied also to other bodies of troops), *an array*.

**Pictones** (**Pect-**), -um, [Celtic], M. plur., a Celtic tribe south of the Loire (*Poitou*).

**pietās**, -tātis, [piō + tas], F., *filial affection, affection* (for the gods, or one's country, etc.), *patriotism*.

**pilum**, -ī, [?], N., a *pestle*. — Also, a *javelin* (the peculiar weapon of the Roman legion, with a heavy shaft 2 or 3 in. thick and 4 ft. long, and an iron head, making a missile more than 6 ft. long, and weighing over 10 lbs.): **pilum murale**, a still heavier missile for use in siege works.

**pilus**, -ī, [pilum], M., a *century* (of soldiers, a name applied in indication of the rank of centurions, see **centurio**). — Also, a *centurion* (of a particular rank). — Phrases: **primipili centurio** (*of the first century or rank*); **primum pilum duxerat** (*had commanded in the first century of the first cohort*).

**pinna**, -ae, [= **penna** (√PET + na)], F., an *artificial parapet* (of osier or the like run along the top of a wall).

**Pirustae**, -ārum, [?], M. plur., a tribe of Illyria.

**piscis**, -is, [?], M., a *fish*. — Collectively, *fish*.

**Pisō**, -ōnis, [pisō + o], M., (a man with a wart like a pea?, cf. **Cicero**), a Roman family name. — Esp.: 1. *Lucius Calpurnius Piso*, a legatus in the army of Cassius which was defeated by the Helvetii B.C. 107, and grandfather of No. 2. — 2. *Lucius Calpurnius Piso Caesonius*, father of Calpurnia, Cæsar's wife. — 3. *Marcus Pupius Piso Calpurnianus*, consul with M. Messala in B.C. 61. — 4. *Piso*, an Aquitanian (probably enfranchised by one of the above named).

**pix**, picis, [?], F., *pitch*.

**placeō**, -ui, -itus, -ēre, [†placō- (cf. **Viriplaca**, **placo**, and **placidus**)], 2. v. n., *please*. — Esp. in third person, *it pleases* (one), *one likes, one determines*.

**placidē** [old abl. of **placidus**], adv., *quietly*.

**plācō**, -āvī, -ātus, -āre, [†placa- (cf. **Viriplaca**)?, or placō- (cf. **placidus**)], 1. v. a., *pacify, appease*.

**Planus**, -ī, [perh. akin to **planus**], M., (*Flat-foot*), a Roman family name. — Esp., *Lucius Munatius Planus*, a legatus of Cæsar.

**plānē** [old abl. of **planus**], adv., *flatly, clearly*.

**plāniciēs**, see **planities**.

**plāntiēs**, -ēī, [planō + ties, cf. -tia], F., *a plain*.

**plānus**, -a, -um, [unc. root + nus], adj., *flat, level: carinae planiores* (*less deep, less rounding*).

**plēbs** (**plēbēs**), -is (-ēī), [√PLE (in **plenus**) + unc. term. (cf. **turba**)], F., *the populace, the multitude, the common people*.

**plēnē** [old abl. of **plenus**], adv., *fully, entirely*.

**plēnus**, -a, -um, [ple (in **pleo**) + nus], adj., *full: luna; legio*.

**plērumque**, see **plerusque**.

**plērusque**, -aque, -umque, [√PLE (in **pleo**) + rus, que (cf. -pletus, **plenus**)], adj. only in plur., *most of, very many*. — Acc. sing. as adv., **plērumque**, *generally, usually, for the most part, very often*.

**Pleumoxii**, -ōrum, [Celtic], M. plur., a people of Belgic Gaul, clients of the Nervii.

**plumbum**, -ī, [?], N., *lead*. — **plumbum album**, *tin*.

**plūrimus**, see **multus**.

**plūs**, see **multus**.

**pluteus**, -ī, [?], M., *a mantelet, a cover* (movable, for defence). — Also, *a bulwark, a defence, a breastwork*.

**pōculum**, -ī, [root (or stem) PO- (in **potus**) + culum], N., *a drinking-cup*.

**poena**, -ae, [perh. †povi- (√PU) + na (cf. **punio**)], F., *a penalty*. Hence, *a punishment* (see **persolvo**, **repeto**, **constituo**).

**poenitet**, see **paenitet**.

**pollex**, -icis, [?], M., *the thumb* (with or without **digitus**).

**polliceor**, -licitus, -licerī, [†por- (= Gr. πρὸς, cf. **portendo**) -liceor]. 2. v. dep., *offer, promise* (voluntarily): **liberaliter** (*made liberal offers*).

**pollicitātiō**, -ōnis, [pollicitā + tio], F., *an offer, a promise*.

**pollicitus**, -a, -um, p.p. of **polliceor**.

**Pompējus**, -ī, [†pompe- (dialectic form of **quinque**) + ius], M., a Roman gentile or family name. — Esp.: 1. *Cneius Pompeius*, the great rival of Cæsar, consul with Marcus Crassus in B.C. 58. — 2. *Cneius Pompeius*, an interpreter of Quintus Tiberius, probably a Gaul enfranchised by one of the Pompeys.

**pondus**, -eris, [√PEND (in **pendo**) + **us**], N., *weight*.

**pōnō**, posuī, positus, pōnere, [prob. †por-sino (cf. **polliceor**)], 3. v. a., *lay down, place*: **posita tollere** (*things laid up, consecrated*); **ponere custodes** (*set*); **castra** (*pitch*); **praesidium** (*station, but see below*). — Fig., *place, lay, make depend on*: **in fuga praesidium**; **spem salutis in virtute** (*find, found, seek*). — **positus**, -a, -um, p.p., *situated, lying, depending on*: **posita est** (*lies*); **positum est in**, etc. (*depends on, etc.*).

**pōns**, pontis, [?], M., *a bridge*.

**populātiō**, -ōnis, [populā + tio], F., *a plundering, a raid*.

**populus**, -ātus, -ārī, [populō-], 1. v. dep., (*strip, of people?*, cf. Eng. *skin, shell, bark a tree*), *ravage, devastate*.

**populus**, -ī, [√PAL? (in **pleo**) reduplicated + **us**], M., (*the full number, the mass*), *a people* (in its collective capacity), *a nation, a tribe* (as opposed to individuals): **populus Romanus** (the official designation of the Roman state).

**porrectus**, -a, -um, p.p. of **porrigo**.

**porrigō**, -rēxī, -rectus, -rigere, [†por-(cf. **polliceor**)-rego], 3. v. a., *stretch forth*: **porrecta loca pertinent** (*stretch out in extent*).

**porrō** [?], akin to †por (cf. **porrigo**), adv., *furthermore, further, then* (in narration).

**porta**, -ae, [√POR (cf. Gr. πόςος) + †a], F., (*way of traffic?*), *a gate*.

**portō**, -āvī, -ātus, -āre, [porta-?], 1. v. a., *carry* (perh. orig. by way of traffic), *bring*.

**portōriumi**, -ī, [?, porta (reduced) + orium (N. of -orius), perh. orig.

†portor + ius], N., (*gate-money? or carrier's money?*), *a duty* (an impost), *a toll*.

**portus**, -tūs, [√POR (cf. **porta**) + **tus**], M., (*a place of access*), *a harbor, a haven, a port*.

**poscō**, poposci, no p.p., *poscere*, [perh. akin to **prex**], 3. v. a., *demand* (with some idea of claim, stronger than **peto**, weaker than **flagito**), *require, claim*.

**positus**, -a, -um, p.p. of **pono**.

**possessiō**, -ōnis, [†por-†sessio (cf. **obsessio**)], F., *possession, occupation*. — Concretely (as in Eng.), *possessions, lands* (possessed).

**possideō**, -sēdī, -sessus, -sidēre, [†por-sedeo], 2. v. a., (*settle farther on?*), *occupy* (in a military sense), *possess* (lands, of a people), *hold possession of*.

**possum**, potuī, posse, [pote (for **potis**) -sum], irr. v. n., *be able, can* (etc.): **plurimum posse** (*be most powerful, have very great influence*); **tantum potest** (*has so much weight, power, influence*); **largiter posse** (*have great influence*); **multitudine posse** (*be strong in numbers*); **equitatu nihil posse** (*have no strength in cavalry*); **quicquid possunt** (*whatever power they have*); **quid virtute possent** (*what they could do by valor*); **fieri posse** (*be possible*); **ut spatium intercedere posset** (*might intervene*); **quam maximum potest** (*the greatest possible*).

**post** [?, prob. abl. of stem akin to **postis** (cf. **ante, antes, rows, and antae, pilasters**)], adv. and prep., *behind, after*: **post diem tertium** (*three days after*); **post se** (*in their rear*); **post hunc** (*next to him*).

**posteu** [post ea], adv., *afterwards*.

**posteaquam** [postea quam], conjunctive adv., (*later than*), *after* (only with clause).

**posterus**, -a, -um, [post- (or stem akin) + terus (orig. compar.)], adj., *the next, later*: **postero die** (*the next day*); **in posterum** (*the next day*). — **postrēmus**, -a, -um, superl., *last*. — **postrēmō**, abl., *lastly, finally*.

**postpōnō**, -posuī, -positus, -pōnere, [post-pono], 3. v. a., *place behind, postpone*: **omnibus rebus postpositis** (*disregarding everything else*).

**postpositus**, -a, -um, p.p. of **postpono**.

**postquam** [post quam], conjunctive adv., (*later than*), *after*.

**postrēmō**, see **posterus**.

**postrēmus**, see **posterus**.

**postridiē** [†posteri (loc. of posterus) -die], adv., *the next day*: **postridie ejus diei** (*the next day after that*).

**postulātum**, -ī, [N. p.p. of **postulo**], N., *a demand, a requirement, a request*.

**postulō**, -āvī, -ātus, -āre, [?], 1. v. a., *claim* (with idea of right, less urgent than **posco**), *ask, request, require*: **tempus anni** (*require, make necessary*).

**potēns**, -entis, [p. of **possum** as adj.], adj., *powerful*: **homo** (*influential*); **potentiores** (*men of influence*).

**potentātus**, -tūs, [potent + atus, cf. **consulatus**], M., *the chief power*.

**potentia**, -ae, [potent + ia], F., *power* (political influence), *authority* (not official or legal).

**potestās**, -tātis, [potent + tas], F., *power* (official, cf. **potentia**, and civil, not military, cf. **imperium**), *power* (generally), *control, ability*,

*opportunity, chance*: **sui potestatem facere** (*give a chance at them, give an opportunity to fight them*); **se potestati alicujus permittere** (*surrender, etc.*); **consistendi potestas erat nulli** (*chance, possibility*); **discedendi potestatem facere** (*give permission, etc.*); **facta potestate** (*having obtained permission*); **imperium aut potestas** (*military or civil power*); **deorum vis ac potestas** (*the power and dominion*).

**potior**, potitus, potiri, [poti-, cf. **potis**], 4. v. dep., *become master of, possess one's self of, get the control of*: **imperio** (*secure*); **castris** (*capture*).

**potior**, -us, -ōris, [compar. of **potis**], adj., *preferable*. — **potius**, acc. as adv., *rather*.

**potitus**, -a, -um, p.p. of **potior**. **prae** [unc. case-form of same stem as **pro**], adv. (in composition) and prep., *before, in comparison with*. — Esp. with words implying hindrance, *for, on account of* (some obstacle). — In composition, *before others, very, before, at the head of*.

**praeacūtus**, -a, -um, [prae-acutus (p.p. of **acuō**)], p.p. as adj., *sharpened to a point, pointed*.

**praebeō**, praebuī, praebitus, praebēre, [prae-habeo], 2. v. a., (*hold before one*), *offer, present, furnish*: **munimenta** (*furnish, and so afford, make*).

**praeceveō**, -cāvī, -cautus, -cavēre, [prae-caveo], 2. v. n., *take care beforehand, take precaution, be on one's guard*.

**praeceđō**, -cēssī, -cēssus, -cēdere, [prae-cedo], 3. v. a., *go before*. — Fig., *excel*.

**praeceps**, -cipitis, [prae-caput],

adj., *headlong, in haste*: **locus praecipitior** (*a steep incline*).

**praecipitum**, -ī, [p.p. of **praecipio**], N., *an instruction, an order*.

**praecipitum**, -a, -um, p.p. of **praecipio**.

**praecipitō**, -cēpī, -ceptus, -cipere, [prae-capio], 3. v. a., *take beforehand, anticipate*.— Also, *order, give instructions*.

**praecipitō**, -āvī, -ātus, -āre, [prae-cipit-], 1. v. a., *throw headlong*: **se** (*plunge headlong*).

**praecipuē** [old abl. of **praecipuus**], adv., *especially*.

**praecipuus**, -a, -um, [prae-†capuus (√CAP + vus)], adj., (*taking the first place*), *special*.

**praecūdō**, -clūsī, -clūsus, -clūdere, [prae-claudo], 3. v. a., (*close in front of some one or something*), *shut off, barricade*.

**praecō**, -ōnis, [?], M., *a herald*.

**Praecōninus**, -ī, [praecon + inus], M., *a Roman family name*.— Esp., *Marcus Valerius Praeconinus*, *a legatus in the army of Crassus*.

**praecurrō**, -cucurrī (-currī), -cursūrus, -currere, [prae-curro], 3. v. n., *run on before, hasten on before, hasten in advance, hurry on before*: **equites** (*ride on in advance*); **celeritate** (*get the start of, etc.*).

**praeda**, -ae, [prob. prae-†hida (root of -hendo + a)], F., *booty, prey*.

**praedicō**, -āvī, -ātus, -āre, [†praedicō- (or similar stem from prae with √DIC)], 1. v. a. and n., *make known (before one), proclaim, describe, boast, vaunt one's self*.

**praedor**, -ātus, -ārī, [praeda], 1. v. dep., *plunder, take booty*.

**praedūcō**, -dūxī, -ductus, -dūcere, [prae-duco], 3. v. a., *lead, etc.*

(see **duco**) *before*: **murum** (*carry out, draw round*).

**praefectus**, -a, -um, p.p. of **praeficio**.— As subst., see **praeficio**.

**praeferō**, -tulī, -lātus, -ferre, [prae-fero], irr. v. a., *place before, esteem above, prefer to (with quam)*; **se alicui** (*show one's self better than*).

**praeficiō**, -fēcī, -fectus, -ficere, [prae-facio], 3. v. a., *put before, place in command of, set over*.—

**praefectus**, p.p. as subst., *a captain (esp. of cavalry), a commander*.

**praefigō**, -fīxī, -fixus, -figere, [prae-figo], 3. v. a., *fix in front, set on the edge (of something)*.

**praefixus**, -a, -um, p.p. of **praefigō**.

**praemetuō**, no perf., no p.p., -metuere, [prae-metuo], 3. v. a. and n., *fear beforehand*.

**praemittō**, -mīsī, -missus, -mittere, [prae-mitto], 3. v. a., *send forward, send on*.

**praemium**, -ī, [?, perh. praetemium (√EM, in emo, + ium)], (taken before the general distribution or disposal of booty?), N., *a reward, a prize, distinction (as a reward or prize)*: **magno praemio remunerari** (*a great price*).

**praeeoccupō**, -āvī, -ātus, -āre, [prae-occupo], 1. v. a., *take in opposition or beforehand*: **timor animos** (*take complete possession of, to the exclusion of everything else*); **vias** (*close against one*).

**praeeoptō**, -āvī, -ātus, -āre, [prae-opto], 1. v. a., *wish in preference, choose rather*.

**praeparō**, -āvī, -ātus, -āre, [praeparo], 1. v. a., *prepare beforehand*.

**praepōnō**, -posui, -positus, -pōnere, [prae-pono], 3. v. a., *put in command*.

**praerumpō**, -rūpī, -ruptus, -rum-  
pere, [prae-rumpo], 3. v. a., *break off*  
(at the end or in front). — **praerup-**  
**tus**, -a, -um, p.p. as adj., *precipitous*.

**praeruptus**, -a, -um, p.p. of **prae-**  
**rumpo**.

**praesaepiō** (-sēp-), -saepsī, -saep-  
tus, -saepire, [prae-saepio], 4. v. a.,  
*hedge in, wall off*.

**praesaepus**, -a, -um, p.p. of  
**praesaepio**.

**praescribō**, -scripsī, -scriptus,  
-scribere, [prae-scribo], 3. v. a.,  
(*write down beforehand*), *prescribe*,  
*order, direct*.

**praescriptum**, -ī, [N. p.p. of  
**praescribo**], N., *an order, orders*.

**praescriptus**, -a, -um, p.p. of  
**praescribo**.

**praesēns**, -entis, p. of **praesum**.

**praesentia**, -ae, [praesent + ia],  
F., *presence, the present moment*: **in**  
**praesentia** (*for the moment, at the*  
*moment*).

**praesentiō**, -sēnsī, -sēnsus, -sen-  
tīre, [prae-sentio], 4. v. a., *see be-*  
*forehand, find out in time, find out*  
(beforehand).

**praesēpiō**, see **praesaepio**.

**praesertim** [as if acc. of †**prae-**  
**sertis** (√SER, in sero, + tis)], adv.,  
*especially*.

**praesidium**, -ī, [prae-†sidium  
(√SED + ium)], cf. **obsidium**, N.,  
(*a sitting down before*), *a guard, a*  
*garrison, a force* (detached for oc-  
cupation or guard). — Fig., *protec-*  
*tion, assistance, support*: **praesidio**  
**literarum** (*with the assistance of*,  
etc.); **in fuga praesidium ponere**  
(*seek safety in flight*).

**praestō** [?, perh. "praesto," *I*  
*am here* (as if quoted)], adv., *on*  
*hand, ready, waiting for*: **praesto**  
**esse** (*be waiting for, meet*).

**praestō**, -stiti, -stātus (-stitus),  
-stāre, [prae-sto], 1. v. a. and n., *stand*  
*before, be at the head, excel, be su-*  
*perior*: **praestat** (*it is better*). —  
Also, causatively, (*bring before*), *fur-*  
*nish, display*: **officium** (*discharge,*  
*perform*); **stabilitatem** (*afford,*  
*possess*); **fidem** (*keep, perform one's*  
*duty*).

**praesum**, -fuī, -esse, [prae-sum],  
irr. v. n., *be in front, be at the head*  
*of, be in command*: **magistratui**  
(*hold*). — **praesēns**, -entis, p., *pres-*  
*ent, immediate*: **pluribus praesen-**  
**tibus** (*in the presence of many*);  
**praesens adesse** (*be present in per-*  
*son*).

**praeter** [compar. of **prae** (cf.  
**inter**)], adv. and prep., *along by,*  
*past, beyond*. — Fig., *except, beside,*  
*contrary to*.

**praetereā** [praeter-ea (abl.?)],  
adv., *furthermore, besides*: **si nemo**  
**praeterea** (*if no one else*).

**praetereō**, -iī, -itus, -īre, [praeter-  
eo], irr. v. a. and n., *go by, pass by*.  
— **praeteritus**, -a, -um, p.p. as adj.,  
*past*. — Esp. N. plur., **praeterita**,  
*the past* (cf. "bygone").

**praeternittō**, -mīsī, -missus,  
-mittere, [praeter-mitto], 3. v. a.,  
*let go by, let slip, omit, neglect*.

**praeterquam** [praeter-quam],  
conjunctive adv., *except*.

**praetor**, -tōris, [prae-†itor (√I +  
tor)], M., (*a leader*), *a commander*.  
— Esp., *a praetor*, one of a class of  
magistrates at Rome. In early times  
two had judicial powers and the  
others regular commands abroad.  
Later all during their year of office  
had judicial powers, but like the  
consuls (who were originally called  
praetors) they had a year abroad as  
propraetors: **legatus pro praetore**



(*legatus in command*, acting as a praetor).

**praetōrius**, -a, -um, [praetor + ius], adj., of a praetor (in all its senses); praetoria cohorts (*the body guard*, of the commander, see praetor).

**praeūrō**, -ūssi, -ūstus, -ūrere, [prae-uro], 3. v. a., burn at the end (in front); praestae sudes (*burnt at the point*, to harden them).

**praeustus**, -a, -um, p.p. of praeturo.

**praevertō**, -verti, -versus, -vertere, [prae-vertō], 3. v. a., anticipate, forestall, attend to first.

**prāvus**, -a, -um, [?], adj., crooked. — Fig., wrong, vicious.

**prehendō** (prendō), -hendi, -hēnsus, -hendere, [prae-†hendo], 3. v. a., seize (against some one else?), seize (generally), take.

**premo**, pressi, pressus, premere, [?], 3. v. a., press. — Esp., press hard, attack fiercely, harass, oppress: se ipsi (*crowd, impede, embarrass each other*).

**prendō**, see **prehendo**.

**pretium**, -ī, [?], N., a price, cost.

**†prex**, precis (dat., acc., and abl. only; plur. entire), [?], F., a prayer, an entreaty.

**pridiē** [loc. of stem of **pro** (prae?) -die, cf. **postridie**], adv., the day before.

**primipilus** [primō-pilus], M., the first centurion (see **centurio** and **pilus**).

**primō** [abl. of **primus**], adv., at first (opposed to afterwards, cf. **primum**).

**primum** [acc. of **primus**], adv., first (in order of incidents, opposed to next, etc), in the first place: cum

**primum** (as soon as); quam **primum** (as soon as possible).

**primus**, -a, -um, see **prior**.

**prīnceps**, -ipis, [primō-(reduced) -†ceps (√CAP as stem)], adj., (*taking the lead*), first, chief, foremost: principes belli inferendi (*leaders in*, etc.); locus (*chief, highest*); ea princeps persolvit (*chiefly*). — Often as subst., leading man, leader, chief man, chief: legationis (*head*).

**prīncipātus**, -tūs, [princip + atus, cf. **consulatus**], M., foremost position, first place, highest place, the lead (in power and influence among states).

**prior**, -us, -ōris, [compar. of stem of **pro**], adj., former, before: priores (*those in front*); non priores inferre (*not the first to*, etc.). — **prius**, N. as adv., before (see also **priusquam**). — **primus**, -a, -um, superl., first: agmen (*front*); primos civitatis (*the best men*); a prima obsidione (*from the beginning of the siege*): in primis (*especially*). — See **primo** and **primum**.

**prīstinus**, -a, -um, [prius-tinus, cf. **diutinus**], adj., (*of former times*), old, former: pristinus dies (*the day before*).

**prius**, see **prior**.

**priusquam** [prius-quam], conj. adv., (*earlier than*), before.

**prīvātium** [as if acc. of †privatis (privā + tis)], adv., privately, as private persons (opp. to magistratus): de suis privatim rebus (*their own private affairs*); plus posse privatim (*in their own name*, opposed to official action).

**prīvātus**, -a, -um, [p.p. of **privo**], adj., (destitute of official character), private, personal.

**prō** [for **prod**, abl. of stem akin

to **prae, prior**, etc.], adv. (in comp.) and prep., *in front of, before*. Hence, *in place of, instead of, for, as, on behalf of*: **nihil pro sano** (*nothing prudent*). — Also, *in view of, in accordance with, in proportion to, according to, considering, in return for, for*. — In comp., *before, forth, away, for, down* (as falling forward).

**probātus**, -a, -um, p.p. of **probo**.

**probō**, -āvī, -ātus, -āre, [probō-], I. v. a., (*make good, find good*), *aprove, test, prove, show, be satisfied with, favor* (a plan), *adopt* (a measure).

**prōcēdō**, -cēssī, -cēssus, -cēdere, [pro-cedo], 3. v. n., *go forward, advance, proceed*: **longius** (*go to a distance*).

**Procillus**, -ī, [Proculō + lus], M., a Roman family name. — Esp., *Cuius Valerius Procillus*, a Gaul sent by Cæsar as ambassador to Ariovistus.

**prōclinātus**, -a, -um, p.p. of **proclino**.

**prōclinō**, -āvī, -ātus, -āre, [pro-clino], I. v. a., (*bend forward*), *throw down*: **res proclinata** (*falling, ruined*).

**prōcōnsul**, -ulis, [pro-consul, on account of the phrase **pro consule**], M., a *proconsul, an ex-consul* (during his term of service abroad).

**procul** [?, †procō- (pro + cus) + lus (reduced, cf. **simul**)], adv., *at a distance* (not necessarily great), *at some distance*.

**prōcumbō**, -cubūī, no p.p., -cumbere, [pro-cumbo], 3. v. n., *fall* (forward), *fall* (generally), *sink down, lie down* (for rest), *become lodged* (of grain). — Less exactly, *incline, slope, lean*.

**prōcūrō**, -āvī, -ātus, -āre, [pro-

**curo**], I. v. a., *care for, have charge of, attend to*.

**prōcurrō**, -currī (-cucurrī), -currūs, -currere, [pro-curro], 3. v. n., *run forward, charge, rush out*.

**prōdeō**, -ivī (-iī), -itus, -ire, [prod (see **pro**) -eo], irr. v. n., *go forth, come forth, come out, go forward*: **longius** (*go to any distance*).

**prōdesse**, see **prōsum**.

**prōditio**, -ōnis, [pro-†ditio, cf. **prodo**], F., (*a giving away*), *treason*.

**prōditor**, -tōris, [pro-dator (cf. **prodo**)], M., *a traitor*.

**prōditus**, -a, -um, p.p. of **prodo**.

**prōdō**, -didī, -ditus, -dere, [pro-do], 3. v. a., (*give forward*), *give forth, publish, betray* (give away), *transmit, hand down*: **memoriam** (*preserve, by handing down to posterity*); **memoria proditum** (*told in tradition, handed down*).

**prōdūcō**, -dūxī, -ductus, -dūcere, [pro-duco], 3. v. a., *lead forth, lead out, bring out* (**jumenta**), *draw up* (troops). — Fig., *protract*.

**prōductus**, -a, -um, p.p. of **produco**.

**proelior**, -ātus, -ārī, [proeliō-], I. v. dep., *fight* (in war).

**proelium**, -ī, [?], N., *a battle* (a single encounter, great or small), *a contest, an engagement, a general engagement, a skirmish*: **committere** (*engage, join battle, risk a battle, begin an engagement, begin the fight, fight*); **suos a proelio continere** (*from battle*).

**prōfectio**, -ōnis, [pro-factio (cf. **proficiscor**)], F., *a setting out, a departure, retreat* (the special idea coming from the context), *starting, evacuation*.

**prōfectus**, -a, -um, p.p. of **proficio**.

**prōfectus**, -a, -um, p.p. of **proficiscor**.

**prōferō**, -tulī, -lātus, -ferre, [**pro-fero**], irr. v. a., *bring forth, bring out*.

**prōficiō**, -fēcī, -fectūrus, -ficere, [**pro-facio**], 3. v. n., (*make way forward*), *advance* (cf. **proficiscor**). — Fig., *gain advantage* ("get on"), *gain* (much or little), *accomplish* (something): **satis ad laudem profectum est** (*enough has been done for glory*); **ad pacem parum profici** (*not much was doing towards peace*); **plus multitudine telorum proficere** (*have the advantage in*).

**proficiscor**, -fectus, -fiscī, [**pro-†faciscor** (cf. **proficio**)], 3. v. dep., (*make way forward*). — Esp., *start, leave, depart, set out, withdraw, march out, go out, come out, sail out*: **quo proficiscimur** (*whither we are going*); **unde erant profecti** (*whence they had come*); **ad proficiscendum pertinere** (*to a journey, etc.*).

**profiteor**, -fessus, -fiterī, [**pro-fateor**], 2. v. dep., *declare publicly*: **se** (*offer one's self, volunteer as, declare one's self*).

**prōfligātus**, -a, -um, p.p. of **profligo**.

**prōfligō**, -āvī, -ātus, -āre, [**†profligō**- (**pro-†fligus**, √FLIG + us)], 1. v. a., (*dash to the ground*). — Esp., *put to rout, rout*.

**prōfluō**, -flūxī, no p.p., -fluere, [**pro-fluo**], 3. v. n., *flow forth, rise*.

**profugiō**, -fūgī, -fugitūrus, -fugere, [**pro-fugio**], 3. v. n., *flee forth, flee, escape, make one's escape*.

**prōgnātus**, -a, -um, [**pro-(g)natus**], p.p. as adj., *sprung from*: **prognati ex** (*descendants of*).

**prōgredior**, -gressus, -gredi, [**pro-gradior**], 3. v. dep., *go forward,*

*march forward, march out, come out*. — Also, fig., *proceed, go*: **amentia longius (go)**.

**prōgressus**, -a, -um, p.p. of **progredior**.

**prohibeō**, -hibuī, -hibitus, -hibēre, [**pro-habeo**], 2. v. a., *hold off, keep off, repel, stop, prevent, restrain, hinder from, forbid*. — Also, *protect* (by a change of relation of the two things concerned): **aliquem ab omni militum injuria** (*keeping the thing protected from the assailant*).

**prohibitus**, -a, -um, p.p. of **prohibeo**.

**prōiciō** (-jiciō), -jēcī, -jectus, -icere, [**pro-iacio**], 3. v. a., *throw forward, throw away, cast* (down, cf. **pro**), *abandon*: **aquilam intra vallum** (*throw over*); **projectae** (*casting themselves*); **se ex navi** (*leap*).

**prōinde** [**pro-inde**], adv., (*from there forward*), *therefore*.

**prōjiciō**, see **proicio**.

**prōlātus**, -a, -um, p.p. of **profero**.

**prōminēns**, -entis, p. of **promineo**.

**prōmincō**, -minuī, no p.p., -minēre, [**pro-†mineo** (cf. **minor**)], 2. v. n., *lean forward, lean over*.

**prōmiscuē** [old abl. of **promiscuus**], adv., *in common*.

**prōmissus**, -a, -um, p.p. of **promitto**.

**prōmittō**, -mīsī, -missus, -mittere, [**pro-mitto**], 3. v. a., (*let go forward*), *let grow* (of the hair): **promisso capillo sunt** (*they wear long hair*).

**prōmontōrium** (**promuntū-**), -ī, [akin to **promineo**], N., *a headland*.

**prōmōtus**, -a, -um, p.p. of **promoveo**.

**prōmoveō**, -mōvī, -mōtus, -movēre, [pro-moveo], 2. v. a., *move forward, advance, push forward.*

**prōmptus**, -a, -um, [p. p. of **promo**], p. p. as adj., (taken out of the store *ready* for distribution), *ready, quick, active.*

**prōnē** [old abl. of **pronus**], adv., *with a slope.*

**prōnūtiō**, -āvī, -ātus, -āre, [pronuntio], 1. v. a., (*publish forth*), *make known, communicate, declare, give orders, make proclamation.*

**prope** [?, akin to **pro**, cf. **procul** and **proximus**], adv. and prep., *near.* — Fig., *almost, nearly.* — Compar., **propius**, *nearer*: **propius tumulum** (as prep.). — Superl., **proximē**, *lately, last.*

**prōpellō**, -pulī, -pulsus, -pellere, [pro-pello], 3. v. a., *drive away* (cf. **pro**), *repulse, rout, dislodge, force back* (changing the point of view).

**properō**, -āvī, -ātus, -āre, [properō-], 1. v. a. and n., *hasten, be in haste, make haste.*

**propinquitās**, -tātis, [propinquo + tas], F., *vicinity, a being near, a position near*: **propinquitates fluminum** (*positions near, etc.*). — Esp., *nearness in blood, a relation* (by blood).

**propinquus**, -a, -um, [stem akin to **prope** (or case-form) + **cus**], adj., *near at hand, near.* — Esp. by blood, *related.* — As subst. in plur., *relatives.*

**propior**, -us, -ōris, [compar. of stem of **prope**], adj., *nearer.* — **proximus** [?, perh. †procō- (see **procul**) + **timus**], superl., *nearest, next, neighboring*: **bellum** (*last*). — With force of prep. (cf. **prope**): **proximi Rhenum** (*nearest the Rhine*).

**prōpōnō**, -posuī, -positus, -pō-

**nere**, [pro-pono], 3. v. a., *place before, set before, lay before*: **vexillum** (*hang out*). — Less exactly, *offer, put in the way, present* (difficulty), *make known, state, represent.*

**prōpositus**, -a, -um, p. p. of **propono**.

**proprius**, -a, -um, [?, akin to **prope**?], adj., *of one's own*: **fines** (*particular*); **hoc proprium virtutis** (*a peculiar property, a mark*).

**propter** [**prope** + **ter**, cf. **aliter**, **praeter**], adv. and prep., *near by.* — Also, *on account of* (cf. "all along of").

**propterea** [**propter**-**ea** (prob. abl. or instr. of **is**)], adv., *on this account.* — With **quod**, *because, inasmuch as.*

**prōpugnātor**, -tōris, [pro-pugnator (cf. **propugno**)], M., *a defender.*

**prōpūgnō**, -āvī, -ātūrus, -āre, [pro-pugno], 1. v. n., (*rush forward to fight, or fight in front*), *rush out* (fighting), *discharge missiles* (**ex silvis**).

**prōpulsō**, -āvī, -ātus, -āre, [propulso (cf. **propello**)], 1. v. a., *repel, keep off, drive off, defend one's self against.*

**prōra**, -ae, [Gr. πρῶρη], F., *the prow* (of a ship).

**prōruō**, -ruī, -rutus, -ruere, [pro-ruo], 3. v. a., *dash down, overthrow, demolish.*

**prōrutus**, -a, -um, p. p. of **pro-ruo**.

**prōsecūtus**, -a, -um, p. p. of **prosequor**.

**prōsequor**, -secūtus, -sequī, [prosequor], 3. v. dep., *pursue, follow* (on one's way), *escort.* — Fig. (from escorting), *address, take leave of one* (with some kind of attention).

**prōspectus**, -tūs, [pro-spectus (cf. **prospicio**)], M., *outlook, view*: in prospectu (*in sight*); prospectu tenebris adempto (*the view cut off by the darkness*).

**prōspiciō**, -spēxi, -spectus, -spicere, [pro-†specio], 3. v. a., *look forward, look out*. — Fig., *provide for, take care, look out*.

**prōsternō**, -strāvī, -strātus, -sternere, [pro-†sterno], 3. v. a., *dash to the ground, overthrow* (lit. and fig.).

**prōsum**, prōfui, prōfutūrus, prōdesse, [pro(d)-sum], irr. v. n., *be for the advantage of, benefit*: quod alicui prodest (*by which one profits*).

**prōtegō**, -tēxi, -tectus, -tegere, [pro-tego], 3. v. a., (*cover in front*), *protect, cover*.

**prōtenus**, see **protinus**.

**prōterreō**, -terrui, -territus, -terrere, [pro-terreo], 2. v. a., *frighten away, drive away in fright*.

**prōterritus**, -a, -um, p.p. of **proterreo**.

**prōtinus** (-tenus), [pro-tenus], adv., *forward, straight on*. Hence, *straightway, forthwith, at once, instantly* (keeping right on).

**prōturbātus**, -a, -um, p.p. of **proturbo**.

**prōturbō**, -āvī, -ātus, -āre, [pro-turbo], 1. v. a., *drive in confusion, drive off, dislodge*.

**prōvectus**, -a, -um, p.p. of **proveho**.

**prōvehō**, -vēxi, -vectus, -vehere, [pro-veho], 3. v. a., *carry forward*. — In pass., *be carried forth, sail out, set sail*: leni Africo provectus (*sail with, be driven by*).

**prōveniō**, -vēni, -ventūrus, -venire, [pro-venire], 4. v. n., *come forward*. — Esp. of fruits, *come up, grow*.

**prōventus**, -tūs, [pro-†ventus,

cf. **eventus** and **provenio**], M., *an issue (a coming forth), success, a result*.

**prōvideō**, -vidi, -visus, -videre, [pro-video], 2. v. a., *foresee, see beforehand, take care, make provision, provide, arrange beforehand*.

**prōvincia**, -ae, [†provincō-(provincus, vinc- as root of **vinco** + us) + ia], F., (office of one extending the frontier by conquest in the field), *office* (of a commander or governor), *a province* (in general), *a function*. — Transferred, *a province* (governed by a Roman magistrate). — Esp., *The Province* (of Gaul); so with **nostra**, **ulterior**, **citerior** (the province, as opposed to the unconquered parts of Gaul).

**prōvinciālis**, -e, [provincia + lis], adj., *of a province*. — Esp., *of the province* (of Gaul).

**prōvolō**, -āvī, -ātūrus, -āre, [pro-volo], 1. v. n., *fly forth*. — Less exactly, *rush forth, rush out, fly out* (of cavalry, etc.).

**proximē**, see **prope**.

**proximus**, see **propior**.

**prōdentia**, -ae, [prudens + ia], F., *foresight, discretion*.

**Ptianiī**, -ōrum, [Celtic], M. plur., *a people of Aquitania*.

**pūbēs** (**pūber**), -eris, [?, prob. same root as **puer**], adj., *adult*. — As subst., *adults, grown men, young men of age*.

**publicē** [old abl. of **publicus**], adv., *publicly, in the name of the state, as a state, on behalf of the state*: **publice jurare** (*for the people, making the oath bind them*).

**publicō**, -āvī, -ātus, -āre, [publicō-], 1. v. a., (*make belong to the people*), *confiscate*.

**publicus**, -a, -um, [populō + cus], adj., *of the people* (as a state),

of the state, public: **consilium** (a state measure, a public measure, action by the state, action by general consent); **res publica** (the commonwealth, the state, the interests of state, public business); **in publico** (in public); **relatis in publicum cornibus** (publicly displayed); **mulieres in publicum procurrere** (abroad into the streets).

**Publius**, -ī, [prob. **populō + ius**, cf. **publicus**], M., a Roman praenomen.

**puĉet**, **puĉuit** (**puĉitum est**), **puĉĉre**, [?], 2. v. impers., (*it shames*), *one is ashamed* (translating the accusative as subject).

**puĉor**, -ōris, [√**PUD** (in **puĉet**) + **or**], M., *shame, a sense of shame, a sense of honor*.

**puer**, -ī, [?], M., *a boy*. — Plur., *children* (of either sex); **a pueris** (*from childhood*).

**puerilis**, -c, [**puerō**- (reduced) + **ilis**], adj., *of a child*: **aetas** (*of childhood*).

**pūgna**, -ae, [√**PUG** (in **pugno**) + **na**], F., *a fight* (less formal than **proelium**): **ad pugnam** (*for fighting*); **genus pugnae** (*of fighting*).

**pūgnō**, -āvi, -ātus, -āre, [**pugna-**], 1. v. n., *fight, engage*. — Often impers. in pass., **pugnatum est**, etc., *an engagement took place, they fought, the fighting continued*. — Esp.: **pugnandi potestatem fecit** (*offered battle*); **pugnantes** (*engaged*).

**pulcher**, -chra, -chrum, [?], adj., *beautiful, handsome, fine*.

**Puliō** (**Pulfio** ?), -ōnis, [?], M., a Roman family name. — Esp., **Titus Pulio**, a centurion in Cæsar's army.

**pulsus**, -a, -um, p.p. of **pello**.

**pulsus**, -ūs, [√**PEL** (in **pello**) + **tus**], M., *a stroke, a beat*: **pulsu re-**

**morum praestare** (*the working, etc.*).

**pulvis**, -eris, [?], M., *dust*.

**puppis**, -is, [?], F., *the stern* (of a ship).

**purgātus**, -a, -um, p.p. of **purgo**. **purgō**, -āvi, -ātus, -āre, [†**purigō**- (**purō** + †**agus**, cf. **prodigus**)], 1. v. a., *clean, clear*. — Fig., *excuse, exonerate, free from suspicion, exculpate*.

**putō**, -āvi, -ātus, -āre, [**putō**- (stem of **putus**, *clean*)], 1. v. a., *clean up, clear up*. — Esp.: *rationes* (*clear up accounts*). Hence, *reckon, think, suppose*.

**Pyrēnaeus**, -a, -um, [?], adj., only with **montes**, *the Pyrenæes mountains*, between France and Spain.

## Q.

**Q.**, abbrev. for **Quintus**.

**quā** [abl. or instr. (?) of **qui**], rel. adv., *by which* (way), *where*.

**quadrāgēni**, -ae, -a, [**quadraginta** (reduced) + **nus**], num. adj., *forty each, forty* (each, often omitted in Eng.).

**quadrāgintā** [akin to **quat-tuor**], indecl. num. adj., *forty*.

**quadringenti**, -ae, -a, [akin to **quattuor**], num. adj., *four hundred*.

**quaerō**, **quaesivī**, **quaesitus**, **quaerere**, [?, with **r** for original **s**], 3. v. a., *search for, look for, inquire about, inquire, ask*: **eadem** (*make the same inquiries*).

**quaestiō**, -ōnis, [**quaes** (as root of **quaero**) + **tio**], F., *an investigation*: **habere de aliquo** (*examine, as witnesses, usually by torture*).

**quaestor**, -tōris, [quaes- (as root of **quaero**) + tor], M., (*investigator*, or *acquirer*, perh. both). — Esp., a *quaestor* (the Roman officer who had charge of the finances of an army).

**quaestus**, -tūs, [quaes (as root of **quaero**) + tus], M., *acquisition*.

**quālis**, -e, [quō- (stem of **quis**) + alis], interr. adj., *of what sort*: **qualis ascensus** (*what is the nature of*, etc.).

**quam** [case-form of **quis** and **qui**, cf. **tam**, **nam**], adv. and conj.: 1. Interrog., *how?* — 2. Relative, *as*, *than*: **praeferre quam** (*rather than*). — Often with superlatives, *as much as possible*: **quam maximas** (*the greatest possible*); **quam maxime** (*very much*). — See also **postquam**, **priusquam**, which are often separated, but are best represented in Eng. together.

**quam diū** [quam, diu], adv., *as long as*.

**quam ob rem** (often found together), adv. phrase: 1. Interrog., *why?* — 2. Relative, *on which account*, *for which reason*.

**quamvis** [quam vis], adv., *as you please*, *however*, *no matter how*.

**quandō** [quam + unc. case-form akin to **de**], adv.: 1. Indef., *at any time*: **si quando** (*if ever*, *whenever*). — 2. Interrog., *when?* — 3. Relative, *when*.

**quantō**, see **quantus**.

**quantopere**, see **opus**.

**quantus**, -a, -um, [prob. for **ka-** (root of **qua**) + **vant** + **us**], adj.: 1. Interrog., *how great?* *how much?* **quantum boni** (*how much good?*); **quantae civitates** (*how important?*). — 2. Relative, *as great*, *as*: **quanta . . . tanta pecunia** (*whatever . . . the same amount of*, etc.): **quantae-**

**vis** (or separate) **copiae** (*any how- ever great*, cf. **quamvis**).

**quārē** [qua-re], adv., *by which thing*, *wherefore*, *therefore*, *on account of which* (circumstance, etc.), *why*. — The relative and interrogative senses are not always distinguishable; **neque commissum quare** (*nothing had been done for which*, etc.); **res hortabantur quare**, etc. (*many reasons for doing so urged*, etc., to, etc.).

**quartus**, -a, -um, [quattuor- (reduced) + tus], adj., *fourth*: **quartus decimus** (*fourteenth*).

**quasi** [quam (or quā) -si], conj., *as if*: **quasi vero** (*as if forsooth*, ironical).

**quattuor** [?, reduced pl.], indecl. num. adj., *four*.

**quattuordecim** [quattuor-decem], indecl. num. adj., *fourteen*.

**-que** (always appended to the word or to some part of the phrase which it connects) [unc. case-form of **qui**], conj., *and*. — Sometimes connecting the general with the particular, *and in general*, *and other*.

**quem ad modum**, phrase as adv., *how*, *just as*, *as*.

**queror**, questus, queri, [?, with **r** for original **s**], 3. v. dep., *complain*, *complain of*, *find fault*, *find fault with*, *bewail*.

**questus**, -a, -um, p.p. of **queror**.

**quī**, quae, quod, cūjus, [prob. quō- + **i** (demonstrative)], rel. pron., *who*, *which*, *that*. — Often where a demonstrative is used in Eng., *this*, *that*. — Often implying an antecedent, *he who*, etc.: **ea quae** (*things which*, *whatever*); **qua de causa** (*for this reason*); **qui patebant** (*though they*, etc.); **qui videant** (*men to see*, *scouts*); **quī** (*and they*);

**habere sese quae**, with subj. (*something to*, etc.); **qui potuissent** (*men who*); **qui postularent** (*to demand*); **haec esse quae** (*this was what*); **qui faceret** (*in that he*, etc.); **pau- cis diebus quibus** (*after*); **idem quod** (*the same as*). — **quō**, abl. of degree of difference as adv., *the* (more, less, etc.). — See also **quis**, **quod**, 2. **quo**, and 3. **quo**.

**quicumque**, quae-, quod-, [**qui- cumque** (cf. **quisque**)], indef. rel., *whoever, whichever, whatever*.

**quidam**, quae-, quod- (**quid-**), [**qui-dam** (case of  $\sqrt{DA}$ , cf. **nam, tam**)], indef. pron., *a* (possibly known, but not identified), *a certain, certain, a kind of* (referred to as belonging to the class but not exactly the thing spoken of): **artificio quodam** (*a kind of trick*); **quidam ex militibus** (*one*).

**quidem** [unc. case-form of **qui + dem** (from  $\sqrt{DA}$ , cf. **tandem, idem**)], conj., giving emphasis but with no regular English equivalent: **ne . . . quidem** (*not . . . even, not . . . either*); **vestrae quidem certe** (*yours at least, with emphasis*).

**quies**, -ētis, [**quiē-** (stem of **quiesco**, etc.) + **tis** (reduced)], F., *rest, sleep, repose*.

**quies**, -a, -um, [**quiē-** (stem of **quiesco**) + **tus**], p.p. as adj., *at rest, quiet, peaceable, settled, at peace, free from disturbance*.

**quīn** [**qui** (abl. or instr. of **qui**) + **ne**], conj., interrog., *how not?* and relative, *by which not*: **quīn etiam** (*nay even, in fact*). — After negative verbs of hindrance and doubt, *so but what, but what, but that, that, from* (doing a thing), *to* (do a thing); **non dubito quīn** (*I doubt not that*); also, rarely, *I do not hesi-*

*tate to*); **non aliter sentio quīn** (*I have no other idea than that*); **non exspecto quīn** (*I do not delay doing*, etc.); **nec abest ab eo quīn possint** (*it is not far from being the case that, etc.*); **non longius abest quīn** (*it is not farther than, etc., that*).

**quīnam** (**quis-**), quae-, quod- (**quid-**), cūjus-, [**qui-nam**], interr. pron., *who*, etc. (emph.): **quibusnam manibus** (*with what possible, etc.*).

**quīncunx**, -uncis, [**quinque- uncia**], F. (an arrangement of dots in the form marked on the five-ounce piece of copper, ⋆:⋆), *a quīncunx*: **in quīncuncem dispositis** (*in quīncuncial or alternate order*).

**quīndecim** [**quinque-decem**], indecl. num. adj., *fifteen*.

**quīngentī**, -ae, -a, [**quinque- centum**], num. adj., *five hundred*.

**quīnī**, -ae, -a, [**quinque + nus**], adj., *five at a time, five* (at a time, though not so expressed in Eng.).

**quīnquāgintā** [**quinque + unc-** stem], indecl., *fifty*.

**quīnque** [?], indecl. num. adj., *five*.

**quīntus**, -a, -um, [**quinque + tus**], adj., *fifth*. — Esp. as a Roman praenomen (orig. the fifth-born?).

**Quīntus**, -ī, see **quīntus**.

**quis** (**quī**), quae, quid (quod), cūjus [stem **quī-** and **quō-**]: 1. Interrog. pron., *who, which, what*. — 2. Indef., *one, any one, any thing*: **ne quid** (*that nothing*); **ubi quis** (*when any one*).

**quisnam**, see **quīnam**.

**quispiam**, quae-, quid- (quod-), cūjus-, [**quis-piam** (**pe-jam**, cf. **quippe, nempe**)], indef. pron., *any, any one, any thing*.

**quisquam**, quae-, quid-, cūjus-, [**quis-quam**], indef. pron. used sub-



stantively (cf. **ullus**), only with negatives and words implying a negative, making a universal negative, *any one, any thing*.

**quisque**, quae-, quid- (quod-), cūjus-, [quis-que], indef. pron. (distributive universal), *each, each one, every*. — Esp. with superlatives, implying that things are taken in the order of their quality: **nobilissimus quisque** (*all the noblest, one after the other in the order of their nobility*); **antiquissimum quodque tempus** (*the most ancient times in their order*); **decimus quisque** (*every tenth, the tenth part of, one in ten*). — With **ut**, and **ita**, a proposition is indicated, *in proportion as . . . so, the more . . . the more*.

**quisquis**, quaequae, quidquid, cūjuscūjus, [quis, doubled], indef. rel. pron., *whoever, whatever, every one who, all who*.

**quivis**, quae-, quid- (quod-), cūjus-, [qui-vis], indef. pron., *who you please, any one, any whatever* (affirmative), *any* (whatever).

1. **quō**, see **quī**.

2. **quō** [old dat. of **qui**], adv.: 1. Interrog., *whither?* — 2. Relative, *whither, into which, as far as* (i.e., to what end): **quo intrare** (*which*); **habere quo** (*have any place to go to, or the like*). — See also **quoad**.

3. **quō** [abl. of **qui**], as conj., *in order that* (with comparatives), *that: magis eo quam quo* (*than that, than because*). — Esp., **quōminus**, *that not, so that not: recusare quōminus* (*refuse to*).

**quoad** [quo-ad], conj., (*up to which point*), *as far as, until, as long as*.

**quod** [N. of **qui**], conj., (*as to which*), *because, inasmuch as, in that,*

*as for the fact that, the fact that, that, as for* (with clause expressing the action): **quod si** (*now if, but if*).

**quom**, see **cum**.

**quōminus**, see 3. **quo**.

**quoniam** [quom (cum) -jam], conj., (*when now*), *inasmuch as, since, as*.

**quoque** [?], conj., following the word it affects, (*by all means?*), *also, as well*. Cf. **etiam** (usually preceding).

**quōqueversus** (-versum), (also **quōquō-**), as adv., (*turned in every direction*), *in every direction, all about*.

**quot** [quō + ti (unc. form fr. √TA, cf. **tam** ?)], pron. indecl.: 1. Interrog., *how many?* — 2. Relative, *as many, as many as* (with implied antecedent).

**quotannis** [quot-annis], adv., (*as many years as there are*), *every year, yearly*.

**quotidiānus** (cotid-), -a, -um, [quotidie (reduced) + anus], adj., *daily*.

**quotidiē** (cotid-), [quot dies (in unc. form)], adv., *daily*.

**quotiēs** [quot + iens, cf. **quin-quiens**], adv.: 1. Interrog., *how often? how many times?* — 2. Relative, *as often, as often as* (with implied antecedent).

**quum**, late spelling for **cum**, which see.

## R.

**rādix**, -icis, [?], F., *a root*. — Plur., *the roots* (of a tree), *the foot* (of a mountain).

**rādō**, rāsī, rāsus, rādere, [?] 3. v. a., *shave*.

**rāmus**, -ī, [?], M., a branch, a bough, a prong (of antlers).

**rapiditās**, -tātis, [rapidō + tas], F., *swiftness*.

**rapīna**, -ae, [rapī- (as if stem of rapio) + na (F. of -nus)], F., *plunder*. — Plur., *plundering*.

**rārus**, -a, -um, [?], adj., *thin, scattered, singly, in small bodies* (of soldiers), *a few at a time, few* (as being wide apart).

**rāsus**, -a, -um, p.p. of rado.

**ratīō**, -ōnis, [†rati- (ra, in reor, + ti) + o], F., a reckoning, an account, a roll. — Also, *calculation, reason, prudence, terms, a plan, science* (or art, or knowledge, as systematic), *a reason* (as consisting in a calculation), *a manner, a method*: **rationem habere** (*take an account, take account of, have regard to, take into consideration, take care of*, a mercantile term, cf. *account*); **rei militaris** (*art, also nature*); **omnibus rationibus** (*in all ways, in all respects*); **proelii** (*character*); **repscere** (*demand an account, make one responsible*); **rationem habere ut** (*take care that, etc.*); **rationem habere frumentandi** (*take measures for, etc.*).

**ratis**, -is, [?], F., a raft.

**Rauracī** (**Rauriciī**), -ōrum, [Celtic], M. plur., a tribe on the upper Rhine.

**re-**, **red-**, [abl. of unc. stem, perh. akin to -rus], inseparable prep., *back, again, away, out, un-*. — Esp. implying a giving or taking something which is due, or which creates an obligation by the taking, see **recipio**, **refero**.

**rebelliō**, -ōnis, [rebelli + o], F., a renewal of war.

**Rebilus**, -ī, [?], M., a Roman

family name. — Esp., *Caius Caninius Rebilus*, a legatus of Caesar.

**recēdō**, -cēssi, -cēssurus, -cēdere, [re-cedo], 3. v. n., *make way back, retire, withdraw*.

**recēns**, -entis, [prob. p. of lost verb †receo (formed from recō, cf. **recipero**)], adj., (? *just coming back?*), *new, fresh, late*.

**recēnseō**, -cēnsui, -cēnsus, -cēnsēre, [re-censeo], 2. v. a., *review, inspect* (of troops).

**receptāculum**, -ī, [receptā + culum], N., a retreat, a place of refuge.

**receptus**, -a, -um, p.p. of **recipio**.

**receptus**, -tūs, [re-captus, cf. **recipio**], M., a retreat, a way of retreat, a refuge: **receptui canere** (*to sound a retreat*).

**recēssus**, -sūs, [re-†cessus (cf. **recedo**)], M., a retreat: **recessum dare** (*a chance to retreat*).

**recidō**, -cidī, -cāsūrus, -cidere, [re-cado], 3. v. n., *fall again, fall back, fall upon* (one after some one else).

**recipiō**, -cēpi, -ceptus, -cipere, [re-capio], 3. v. a., *take back, get back, recover, take in, receive, admit*: **misericiādiam** (*admit of*); **tela recipi** (*be exposed to missiles*); **ad se** (*attack*). — With reflexive, *retreat, fly, return, retire, get off, withdraw, resort*.

**recitō**, -āvi, -ātus, -āre, [re-cito], 1. v. a., *read* (aloud).

**reclinātus**, -a, -um, p.p. of **reclino**.

**reclinō**, -āvi, -ātus, -āre, [re-clino], 1. v. a. and n., *lean back, lean over, lean*: **reclinatus** (*leaning*).

**rectē** [old abl. of **rectus**], adv., *straight*.

**rectus**, -a, -um, [p.p. of *rego*], adj., (*directed*), *straight*: **recta regione** (*in a straight direction, parallel with*).

**reciperō** (-*cuperō*), -āvi, -ātus, -āre, [†*reciperō*-, from *recō* (cf. *recens*, *reciprocus*) + *parus* (cf. *opiparus*)], I. v. a., *get back, recover, regain*.

**recūsō**, -āvi, -ātus, -āre, [re-†*causo* (cf. *excuso*)], I. v. a. and n., (*give an excuse for drawing back*), *refuse, reject, repudiate, object to*: **de stipendio** (*refuse to pay, etc.*); **quin** (*refuse to*); **quominus** (*refuse to*); **periculum** (*refuse to incur*).

**rēda** (*rhēda*), -ae, [perh. Celtic form akin to *rota*], F., *a wagon* (with four wheels).

**redāctus**, -a, -um, p.p. of **redigo**.

**reddō**, -didi, -ditus, -dere, [re (*red*)-do], 3. v. a., *give back, restore, pay* (something due, cf. *re*), *render*.

**redemptus**, -a, -um, p.p. of **redimo**.

**redeō**, -iī (-iīvi), -itūrus, -īre, [re (*red*)-eo], irr. v. n., *go back, return, come down again* (*collis ad planitiem*): **eodem unde redierat** (*come*).

**redigō**, -ēgi, -āctus, -igere, [re (*red*)-ago], 3. v. a., *bring back, reduce, render, bring* (sub *imperium Galliam*), *make one thing out of another*.

**redimō**, -ēmī, -emptus, -imere, [re (*red*)-emo], 3. v. a., *buy back, redeem, purchase, buy*.

**redintegrātus**, -a, -um, p.p. of **redintegro**.

**redintegrō**, -āvi, -ātus, -āre, [re (*red*)-*integro*], I. v. a., *renew* (again), *restore, revive* (*spem*).

**reditus**, -tūs, [re (*red*)-†*itus*], M., *a return*. — Also **reditiō**, -ōnis.

**Redones**, -um, [Celtic], M. plur., *a tribe of Brittany*.

**redūcō**, -dūxī, -ductus, -dūcere, [re-*duco*], 3. v. a., *lead back, bring back, draw back, draw in*.

**refectus**, -a, -um, p.p. of **reficio**.

**referō**, -tuli, -lātus, -ferre, [re-*fero*], irr. v. a., *bring back, return, bring* (where something belongs), *report*. — Esp.: **ad senatum** (*lay before for action*); **de republica** (*consult in regard to*); **gratiam** (*make return, show one's gratitude*); **pedem** (*retreat, draw back*).

**reficiō**, -fēcī, -fectus, -ficere, [re-*facio*], irr. v. a., *repair, refresh*: **se ex labore** (*rest*); **exercitum** (*allow to recover*).

**refractus**, -a, -um, p.p. of **refringo**.

**refringō**, -frēgī, -fractus, -fringere, [re-*frango*], 3. v. a., *break away, break in* (*portas*): **vim fluminis** (*break, opposite to its direction*).

**refugiō**, -fūgī, -fugitūrus, -fugere, [re-*fugio*], 3. v. n., *run away, escape*.

**Rēginus**, -i, [akin to *rex*], M., *a Roman family name*. — Esp., *Caius Antistius Reginus*, *a legatus of Cæsar*.

**regiō**, -ōnis, [√REG + *io*, but cf. **ratio**], F., *a direction, a part* (of the country, etc.), *a region, a country, a district*: **recta regione** (*straight, along, parallel*); **e regione** (*opposite*).

**rēgius**, -a, -um, [reg + *ius*], adj., *of a king, regal, royal*.

**rēgnō**, -āvi, -ātūrus, -āre, [regnō-], I. v. n., *rule, be in power*.

**rēgnum**, -ī, [√REG + *num* (N. of -nus)], N., *a kingdom, royal power, a throne*. — Plur., *the royal power* (of several cases).

**regō**, rēxī, *rectus, regere*, [akin to

**rex**], 3. v. a, *direct, manage, rule, have control of.*

**regredior**, -gressus, -gredi, [re-gradior], 3. v. dep., *go back, return.*

**rēiciō** (rējiciō), -jēci, -jectus, -icere, [re-jacio], 3. v. a., *throw back, hurl back, drive back, throw away, drive off.*

**relanguēscō**, -languī, no p.p., -languescere, [re-languesco], 3.v. n., *languish away, be relaxed, be weakened, be deadened.*

**relātus**, -a, -um, p.p. of **refero**.

**relēgātus**, -a, -um, p.p. of **relego**.

**relēgō**, -āvi, -ātus, -āre, [re-lēgo], 1. v. a., *remove, separate.*

**relictus**, -a, -um, p.p. of **relinquo**.

**religiō**, -ōnis, [?, re-legio (cf. **religio**)], F., (the original meaning uncertain), *a religious scruple, a religious observance, the service of the gods, a superstition, a superstitious terror.* — Plur., *religious matters* (of all kinds).

**relinquō**, -liquī, -lictus, -linquere, [re-linguo], 3. v. a., *leave behind, leave, abandon: obsidionem(raise).* — Pass., *be left, remain.*

**reliquus**, -a, -um, [re-†liquus (√LIQ + us)], adj., *left, remaining, the rest, the other, other* (meaning all other), *the others, all other, future* (of time, *remaining*); *nihil est reliqui* (*there is nothing left*); *nihil ad celeritatem sibi reliqui fecerunt* (*made the greatest possible speed*).

**remaneō**, -mānsī, -mānsūrus, -manēre, [re-maneo], 2. v. n., *remain behind, remain, stay.*

**rēmex**, -igis, [remō- with unc. term. (perh. †agus)], M., *an oarsman, a rower.*

**Rēmī**, -ōrum, [Celtic], M. plur., a tribe of the Belgae about Rheims, which was their capital.

**rēmigō**, -āvi, -ātūrus, -āre, [re-mig-], 1. v. n., *row.*

**remigrō**, -āvi, -ātūrus, -āre, [re-migro], 1. v. n., *move back.*

**reminiscor**, -miniscī, [re-†miniscor(√MAN, in memini, †isco)], 3. v. dep., *remember.*

**remissus**, -a, -um, p.p. of **remitto**.

**remittō**, -misi, -missus, -mittere, [re-mitto], 3. v. a., *let go back, send back, throw back.* — Fig., *relax, cease to use, give up: remissioribus frigoribus* (*less intense*).

**remollēscō**, -mollēscere, [remollesco], 3. v. n., *soften away, soften, become feeble.*

**remōtus**, -a, -um, p.p. of **removeo**.

**removeō**, -mōvi, -mōtus, -movēre, [re-moveo], 2. v. a., *move back, move away, send away, remove, draw away, get out of the way.*

**remūneror**, -ātus, -ārī, [re-munero], 1. v. dep., *repay, requite.*

1. **Rēmūs**, -ī, [?], M., one of the Remi (which see).

2. **rēmūs**, -ī, [?], M., *an oar.*

**rēnō**, -ōnis, [?], M., *a reindeer.*

**renovō**, -āvi, -ātus, -āre, [re-novo], 1. v. a., *renew.*

**renūntiātus**, -a, -um, p.p. of **renuntio**.

**renūntiō**, -āvi, -ātus, -āre, [renuntio], 1. v. a., *bring back word, report, proclaim.*

**repellō**, -pulī, -pulsus, -pellere, [re-pello], 3. v. a., *drive back, repel, repulse: ab hac spe repulsi* (*disappointed in this hope*).

**repente** [abl. of **repens**], adv., (creeping on so as to appear suddenly), *suddenly.*

**repentīnō**, see **repentinus**.

**repentinus**, -a, -um, [repente +

inus], adj., *sudden, hasty*. — **repentinō**, abl. as adv., *suddenly*.

**reperiō**, repereri, repertus, reperire, [re-(red-)pario], 4. v. a., *find out, discover, find* (by inquiry, cf. **invenio**): **reperiti sunt multi** (*there were many*).

**repertus**, -a, -um, p.p. of **reperio**.

**repetō**, -petivī, -petitus, -petere, [re-peto], 3. v. a., *try to get back, demand back, ask for*: **poenas** (*inflict*, cf. **sumo**).

**repleō**, -plēvī, -plētus, -plēre, [repleo], 2. v. a., *fill up, supply well*.

**replētus**, -a, -um, p.p. of **repleo**.

**reportō**, -āvī, -ātus, -āre, [reporto], 1. v. a., *carry back*.

**reposcō**, -poscere, [re-posco], 3. v. a., *demand back, demand* (something due).

**repraesentō**, -āvī, -ātus, -āre, [repraesento], 1. v. a., *make present, do at once*.

**reprehendō**, -hendī, -hēnsus, -hendere, [re-prehendo], 3. v. a., *drag back, seize hold of, find fault with, blame, censure*.

**repressus**, -a, -um, p.p. of **reprimō**.

**reprimō**, -pressī, -pressus, -primere, [re-premo], 3. v. a., *check*.

**repudiō**, -āvī, -ātus, -āre, [repudiō-], 1. v. a., (*spurn with the feet*, cf. **tripudium**), *spurn, refuse, reject*.

**repugnō**, -āvī, -ātus, -āre, [repugno], 1. v. n., *resist*. — Fig., *be in opposition*.

**repulsus**, -a, -um, p.p. of **repello**.

**requirō**, -quisivī, -quisitus, -quirere, [re-quaero], 3. v. a., *search out*. Hence, *request, require, demand, need*.

**rēs**, **rēi**, [akin to **reor**], F., *property*(?), *business, an affair, a matter, a thing* (in the most general sense), *a fact, an occurrence, an event, a case, an action, an act*. — Often to be translated from the context: **ob eam rem** (*for this reason*); **quam ob rem** (*for which reason, wherefore*); **his rebus** (*by these means, by these reasons, on this account*); **ea res** (*this, often equivalent to a pronoun*); **qua in re** (*in which*); **eius rei** (*of this*); **his rebus cognitit** (*this*); **qua ex re futurum** (*the result of which would be*); **huic rei** (*for this purpose, for this*); **alia re jurare** (*in any other way*); **nihil earum rerum quas**, etc. (*nothing of what, etc.*); **sine certa re** (*without certain grounds*); **omnibus rebus** (*in every respect, in all ways*); **his omnibus rebus unum repugnabat** (*considerations, reasons, arguments*); **quibus rebus occurrendum esse** (*dangers*); **rem deferre** (*lay the matter before, not for consultation, bring information, cf. rem referre*); **rerum omnium casus** (*all accidents*); **rem gerere** (*operate, conduct operations, in war, succeed well or ill*); **his rebus gestis** (*after these operations, events*); **male re gesta** (*want of success*); **rerum natura** (*nature, also, state of the case*); **imperitus rerum** (*ignorant of the world*); **omnium rerum summa** (*of the whole, of all the forces*); **ei rei student** (*this branch, cavalry*); **cujus rei** (*of which, ships*). — Esp., *the affairs* (of a person), *position, interests, condition, fortunes, circumstances*: **Gallicis rebus favere** (*the interests of Gaul*); **rem esse in angusto** (*affairs, things*); **commutatio rerum** (*change of fortunes*).

— Esp.: *res secundae*, or *adversae* (*success, prosperity or adversity, want of success*); *res publica* (*the common-wealth, the state, the general interests, public business*); *res communis* (*the common interest*); *de republica* (*in regard to the welfare of the state*); *res divinae* (*divine worship*, and everything pertaining to it; *religion*); *res familiaris* (*property*); *res militaris* (*warfare, the art of war*); *res frumentaria* (*grain supply, grain*); *res alicui est* (*one has business with, has to do with, and the like; one's affair is*); *res est* (*it is a fact, it is so*); *novae res* (*a new form of government, revolution*).

**resarciō**, no perf., -sartus, -sarcire, [re-sarcio], 4. v. a., *patch up again, repair* (lit. and fig.).

**rescindō**, -scidi, -scissus, -scindere, [re-scindo], 3. v. a., *cut away, tear down, break down, destroy*.

**resciscō**, -scivī, -scitus, -sciscere, [re-scisco], 3. v. a., *find out, learn, discover*.

**rescribō**, -scripsi, scriptus, -scribere, [re-scribo], 3. v. a., *transfer* (by writing).

**reservātus**, -a, -um, p.p. of **reservo**.

**reservō**, -āvī, -ātus, -āre, [re-servo], 1. v. a., *keep back, reserve, hold in reserve*.

**resideō**, -sēdī, no p.p., -sidere, [re-sedeo], 2. v. n., *sit back, sit down, remain behind, remain*.

**residō**, -sēdī, no p.p., -sidere, [re-sido], 3. v. n., *sink down, become calm*.

**resistō**, -stitī, no p.p., -sistere, [re-sisto], 3. v. n., *stand back, stop, withstand, make a stand, resist*.

**respiciō**, -spēxī, -spectus, -spicere, [re-†specio], 3. v. a. and n., *look*

*back, look back at, look behind one, see behind one*.

**respondeō**, -spondi, -spōnsus, -spondere, [re-spondeo], 2. v. n., *reply, answer*.

**respōnsum**, -ī, [N. p.p. of **respondeo**], N., *a reply*. — Plur., *a reply* (of several parts).

**rēpublica**, see **res**.

**respuō**, -spuī, no p.p., -spuere, [re-spuo], 3. v. a., *spit out*. — Fig., *spurn, reject*.

**restinctus**, -a, -um, p.p. of **restinguo**.

**restinguō**, -stinxi, -stinctus, -stinguere, [re-stinguo], 3. v. a., *extinguish*.

**restituō**, -stitui, -stitūtus, -stituire [re-statuo], 3. v. a., *set up again, replace, restore, make anew*.

**restitūtus**, -a, -um, p.p. of **restituo**.

**retentus**, -a, -um, p.p. of **retineo**.

**retineō**, -tinui, -tentus, -tinēre, [re-teneo], 2. v. a., *hold back, restrain* (**quin**, *from doing something*), *detain, retain*: *memoriam* (*preserve*); *Gāllos* (*arrest*).

**retrahō**, -trāxī, -trāctus, -trahere, [re-traho], 3. v. a., *drag back, bring back* (a person).

**revellō**, -vellī, -vulsus, -vellere, [re-vello], 3. v. a., *tear away, pull away*.

**reversus**, -a, -um, p.p. of **revertō**.

**revertō**, -verti, -versus, -vertere, [re-vertō], 3. v. n., *return* (in perf. tenses). — Pass. as deponent in pres. tenses, *return*.

**revinciō**, -vinxī, -vinctus, -vincire, [re-vincio], 4. v. a., *bind back* (to something), *make fast, fasten, bind*.

**revinctus**, -a, -um, p.p. of **re-  
vincio**.

**revocātus**, -a, -um, p.p. of **re-  
voco**.

**revocō**, -āvī, -ātus, -āre, [re-voco],  
I. v. a., *call back, call away, call  
off*.

**rēx**, rēgis, [√REG as stem], M., a  
*king*.

**rhēda**, see **reda**.

**Rhēnus**, -ī, [Celtic?], M., *the  
Rhine*.

**Rhodanus**, -ī, [Celtic?], M., *the  
Rhone*.

**ripa**, -ae, [?], F., *a bank*.

**rivus**, -ī, [akin to Gr. ῥέω], M., a  
*brook, a stream* (not so large as  
**flumen**).

**rōbur**, -oris, [?], N., *oak*.

**rogātus**, -a, -um, p.p. of **rogo**.

**rogō**, -āvī, -ātus, -āre, [?], I. v. a.  
and n., *ask, request, ask for: sacra-  
mento rogare milites* (*bind by an  
oath, enlist under oath*).

**Rōma**, -ae, [?, perh. akin to Gr.  
ῥέω, *the river city*], F., *Rome*.

**Rōmānus**, -a, -um, [Roma+nus],  
M., *Roman*. — As subst., *a Roman*.

**Roscius**, -ī, [?], M., a Roman  
family name. — Esp., *Lucius Roscius*,  
a legatus of Cæsar.

**rostrum**, -ī, [√ROD- (in **rodo**)  
+ **trum**], N., *a beak*. — Esp. of a  
ship, *the beak, the ram* (used as in  
modern naval fighting).

**rota**, -ae, [?], F., *a wheel*.

**rubus**, -ī, [?, perh. rub- (in  
**ruber**) + **us**], M., (*red?*), *a bramble*.

**Rūfus**, -ī, [prob. dialectic form  
= **rubus**, *red*], M., a Roman præ-  
nomen.

**rūmor**, -ōris, [?], M., *a rumor*  
(confused report), *report*.

**rūpēs**, -is, [√RUP + unc. term.],  
F., *a cliff, a rock* (in position).

**rūrsus** [for **reversus**], adv., *back  
again, back, again*.

**Rutēnī**, -ōrum, [Celtic], M. plur.,  
a tribe on the borders of Provence.

**Rutilus**, -ī, [prob. akin to **ruber**],  
M., *red*. — As a Roman family name.  
— Esp., *Marcus Sempronius Ruti-  
lus*, a commander of cavalry under  
Cæsar.

## S.

**Sabinus**, -ī, [unc. stem (cf. **sa-  
bulus**, *sand*) + **inus**], M., (*Sabine*).  
— As a Roman family name. — Esp.,  
*Quintus Titurius Sabinus*, a legatus  
of Cæsar.

**Sabis**, -is, [Celtic], M., a river of  
Gaul flowing into the Meuse, now  
*Sambre*.

**sacerdōs**, -dōtis, [sacrō-dos  
(√DA + **tis**)], c., (*arranger of  
sacred rites?*), *a priest*.

**sacrāmentum**, -ī, [sacrā + men-  
tum], N., *an oath*.

**sacrificium**, -ī, [†sacrificō-  
(sacrō-†facus, cf. **beneficus**) +  
**ium**], N., *a sacrifice*.

**saepe** [N. of †**saepis** (perh. same  
as **saepes**)], adv., *often: minime  
saepe* (*most rarely*). — **saeplus**,  
compar., *many times, repeatedly*.

**saepenumerō** [saepe-numero],  
adv., *oftentimes, many times*.

**saepēs** (sēpēs), -is, [akin to  
**saepe**, **saepio**], F., *a hedge*.

**saeviō**, -iī, -iūrus, -ire, [saevo-  
(as if **saevi**-)], 4. v. n., *be angry,  
rage, be violent*.

**sagitta**, -ae, [?], F., *an arrow*.

**sagittārius**, -ī, [sagitta + arius],  
M., *an archer*.

**sagulum**, -ī, [sagō + lum], N.,  
*a cloak* (military).

**saltus**, -tūs, [?, perh. √SAL (in **salio**) + **tus**], M., a wooded height, a glade, a pass (in the mountains).

**salūs**, -ūtis, [salvō(?) + **tis** (cf. **virtus**, **Carmentis**)], F., health, well-being, welfare, safety, preservation, deliverance, life (as saved or lost); **salute desperata** (despairing of saving one's self); **salutis suae causa** (to protect one's self); **ad salutem contendere** (a place of safety).

**Samarobrīva**, -ae, [Celtic], F., a city of the Ambiani, now *Amiens*.

**sanciō**, sanxi, sanctus, sancire, [√SAC (in **sacer**)], 4. v. a., bind (in some religious manner), make sacred, solemnly establish (by law). — **sancitus**, -a, -um, p.p. as adj., holy, sacred, solemn, inviolable.

**sanguis** (-en), -inis, [?], M., blood (as the vital fluid, generally in the body, cf. **cruor**).

**sānitās**, -tātis, [sanō + **tas**], F., soundness, sound mind.

**sānō**, -āvi, -ātus, -āre, [sanō-], 1. v. a., make sound, make good, repair.

**Santones**, -um, [Celtic], M. plur. (also -ī, -ōrum), a tribe between the Loire and the Garonne.

**Santoni**, see **Santones**.

**sānus**, -a, -um, [√SA- (akin to **salvus**) + **nus**], adj., sound (in body or mind), sane, discreet: **nihil pro sano facere** (nothing discreet).

**sapiō**, -iī (-īvi), no p.p., -ere, [?, √SAP (akin to Gr. σοφός)], 3. v. a. and n., taste (actively or passively). Hence, be wise.

**sarcina**, -ae, [sarci- (as if stem of **sarcio**, or a kindred noun-stem) + **na** (F. of **nus**)], F., a pack (sewed up?). — Plur., *baggage* (soldiers'

packs, cf. **impedimenta**, baggage not carried).

**sarciō**, sarsi, sartus, sarcire, [?], 4. v. a., mend, patch. — Fig., *restore, repair*.

**sarmentum**, -ī, [perh. √SARP- (but cf. **sarcina**) + **mentum**], N., (either *prunings* or *tied fagots*), only in plur., *fagots, fascines*.

**satis** [?], adv., enough, sufficiently. — Often with partitive, equivalent to a noun or adj., enough, sufficient: **satis habere** (consider sufficient, be satisfied); **satis facere** (do enough); **neque . . . satis commode** (not very, etc.); **satis grandis** (rather large, tolerably large).

**satisfaciō**, -fēcī, -factūrus, -facere, [satis facio], irr. v. n., do enough for, satisfy, make amends, excuse one's self, apologize.

**satisfactiō**, -ōnis, [satis-factio (cf. **satisfacio**)], F., amends, excuses, an apology.

**satus**, -a, -um, p.p. of **sero**.

**saucius**, -a, -um, [?], adj., wounded.

**saxum**, -ī, [?], N., a rock (as movable).

**scāla**, -ae, [perh. *scad-* (in **scando**) + **la**], F., a ladder, a scaling ladder.

**Scaldis**, -is, [?], M., a river of Gaul, the *Scheldt* (perh. put in VI. 33 for the *Sambre* by mistake).

**scapha**, -ae, [Gr. σκάφη, orig. a "dug-out"], F., a skiff, a boat.

**scelerātus**, -a, -um, [as if (perh. really) p.p. of **scelero** (*stain with crime?*)], adj., villainous, accursed.

**scelus**, -eris, [?, cf. Gr. σκῆλος, perh. orig. "crookedness," cf. **pravus** and *wrong*], N., crime.

**scienter** [scient + **ter**], adv., knowingly, skilfully.



**scientia**, -ae, [scient + ia], F., *knowledge, acquaintance with* (thing in the genitive).

**scindō**, scidi, scissus, scindere, [√SCID, cf. Gr. σχίω], 3. v. a., *tear, tear down*.

**sciō**, scivī, scītus, scīre, [?], 4. v. a., (*separate?*), *distinguish, know*.

**scorpiō**, -ōnis, [?], M., *a scorpion; a machine for throwing darts*. Hence, *a shot from an engine* (of that kind).

**scribō**, scripsī, scriptus, scribere, [?], 3. v. a. and n., *write, give an account* (in writing).

**scrobis**, -is, [prob. akin to scribo], M. and F., *a ditch*.

**scūtum**, -ī, [?], N., *a shield*, of the Roman legion, made of wood, convex, oblong (2½ by 4 ft.), covered with leather.

**secō**, secuī, sectus, secāre, [prob. causative of √SEC], 1. v. a., *cut, reap*.

**sēcrētō** [abl. of **secretus**, p.p. of **secerno**], adv., *in private, privately*.

**sectiō**, -ōnis, [√SEC (in **seco**) + tio], F., *a cutting*. Hence (probably from dividing in lots), *a lot of booty, booty*.

**sector**, -ātus, -ārī, [prob. **sectā** (√SEQU + ta, cf. **moneta**)], 1. v. dep., *pursue, chase after*.

**sectūra**, -ae, [prob. **sectu-** (√SEC + tus) + ra, F. of **-rus**], F., *a cutting, a mine, a shaft, a gallery*.

**secundum**, see **secundus**.

**secundus**, -a, -um, [part. in **-dus** of **sequor**], adj., *following*. Hence, *second*. — Also (as not opposing), *favorable, successful*: **secundiores res** (*greater prosperity*); **proelium secundum nostris** (*in favor of*); **secundo flumine** (*down the stream*);

**secunda acies** (*the second line of battle, the second division*). — Neut. acc. as prep., *along, in the direction of, in accordance with*.

**secūris**, -is, [√SEC + unc. term.], F., *an axe*. — Esp., *the axe of the licitor* (as a symbol of the power of life and death).

**secus** [√SEQ (in **sequor**) + unc. term.], adv., (*inferior*), *otherwise*. — Compar., **secius**, *less*: **nihilo secius** (*none the less, nevertheless*).

**secūtus**, -a, -um, p.p. of **sequor**.

**sed** [abl. of unc. stem, cf. **re**], conj., *apart* (cf. **seditio**, and **securus**), *but* (stronger than **autem** or **at**).

**sēdecim** [**sex-decem**], indecl. num. adj., *sixteen*.

**sēdēs**, -is, [SED + es (M. and F. term. corresponding to N. **-us**)], F., *a seat*. Hence, *an abode* (both in sing. and plur.): **locus ac sedes** (*a place of abode*).

**sēditō**, -ōnis, [**sed-itiō** (√I + tio)], F., *a secession, a mutiny, an uprising*.

**sēditōsus**, -a, -um, [**sedition** + osus], adj., *seditionous, factious*.

**Sedulius**, -ī, [?], M., a leader of the Lemovices.

**Sedūnī**, -ōrum, [Celtic], M. plur., a tribe of the Alps.

**Sedusī**, -ōrum, [Teut.], M. plur., a tribe of Germans.

**seges**, -etis, [unc. stem + tis], F., *a crop of grain* (growing), *a field* (of grain).

**Sēgnī**, -ōrum, [Celtic], M. plur., a people of Belgic Gaul.

**Segonax** (**-ovax**), -actis, [Celtic], M., a British king.

**Segontiacī**, -ōrum, [Celtic], M. plur., a tribe of Britain.

**Segusiāvi** (**-ūnī**), -ōrum, [Celtic],

M. plur., a people west of the Rhone, near modern Lyons.

**semel** [prob. N. of adj., akin to **similis**], adv., *once*: **semel atque iterum** (*more than once, again and again*); **ut semel** (*when once, as soon as*).

**sēmentis**, -tis, [semen + tis, cf. **Carmentis, virtus**], F., *a sowing*: **sementis (-ēs) facere** (*sow grain*).

**sēmīta**, -ae, [se (sed) -†mīta (√MI, in meo, cf. comes)], F., *a side path, a by path, a path* (over the mountains).

**semper** [†semō-(?) (in **semel**) -per (cf. **parumper**)], adv., *through all time, all the time, always*.

**Semprōnius**, -ī, [?], M., a Roman gentile name. — Esp., *Marcus Sempronius Rutilus*; see **Rutilus**.

**senātor**, -tōris, [†senā- (as if verb-stem akin to **senex**, perh. really so, cf. **senatus**) + tor], M., (*an elder*). Hence, *a senator* (esp. of Rome), *a senator* (of a similar person in Gaul).

**senātus**, -tūs, [†senā- (as if, perh. really, verb-stem akin to **senex**)], M., *a senate* (council of old men). — Esp., *the senate* (of Rome, the great body of nobles acting as an administrative council).

**senex** [seni + cus (reduced)]. — Gen., **senis** [?, cf. *seneschal*], adj. (only M.), *old*. — Esp. as subst., *an old man* (above forty-five).

**sēnī**, -ae, -a, [sec(s) + nī], adj., *six each, six* (where each is implied in Eng. by the context).

**Senones**, -um, [Celtic], M. plur., a tribe of Gaul on the Seine, near *Sens* (their chief town, anciently Agedincum).

**sententia**, -ae, [†sentent- (p. of simpler pres. of **sentio**) + ia], F.,

(*feeling, thinking*). Hence, *a way of thinking, an opinion, a view, a determination, a sentiment, a feeling, a purpose, a design*. — Esp., officially, *a judgment, an opinion, a sentence, a vote*: in *ea sententia permanere* (*of that mind*); in *eam sententiam* (*to this purport*).

**sentio**, sēnsī, sēnsus, sentire, [?], 4. v. a., *perceive* (by the senses), *know, see, think* (of an opinion made up), *learn about, learn*: **unum sentiunt ac probant** (*hold the same opinion, etc.*).

**sentis**, -is, [?], M., *a briar*.

**sēparātim** [as if acc. of †separatis (separā + tis)], adv., *separately, privately* (apart from others).

**sēparātus**, -a, -um, p.p. of **separō**.

**sēparō**, -āvī, -ātus, -āre, [se (sed) -parō], 1. v. a., (*get apart?*), *separate*. — Esp. p.p., **sēparātus**, -a, -um, as adj., *separate*.

**sēpēs**, see **saepes**.

**septem** [?], indecl. num. adj., *seven*.

**septemtrionēs** (**septen-**), -um, [see **trio**], M. plur., *the seven plough oxen* (the stars of the Great Bear). Hence, *the north*. — Also (by an error) in the sing., **septentriō**, -ōnis, *the north*: **ad septentriones** (*to the north*); **a septentrionibus** (*in the north*); **sub septentrionibus** (*in the north, towards the north*); **in septentrionem** (*to the north*).

**septimus**, -a, -um, [septem + mus, cf. **primus**], adj., *the seventh*.

**septingentī**, -ae, -a, [septem (in some form) -centum(?)], num. adj., *seven hundred*.

**septuāgintā** [from **septem**, in some unc. manner], indecl. num. adj., *seventy*.

**sepultūra**, -ae, [†sepultu (sepel, prob. compound, + tus) + ra (F. of rus)], F., *burial, burying*.

**Sēquana**, -ae, [Celtic], F., *the Seine*.

**Sēquanus**, -a, -um, [Celtic], adj., *of the Sequani* (a tribe of Gaul, on the Rhone, N. of Macon). — Masc. plur., the nation itself, *the Sequani*. — Masc. sing., *one of the Sequani*.

**sequor**, secūtus, seqūi, [√SEQU], 3.v. dep., *follow, accompany*: **damnatum poena** (*be inflicted upon*, the penalty following the condemnation); **eventus** (*ensue*); **hiems quae secuta est** (*the following*); **fidem populi Romani** (*hold to, remain under*, etc.); **aestus commutationem** (*take advantage of*); **fidem Caesaris** (*come under, surrender one's self to*).

**sermō**, -ōnis, [√SER (in sero, twine) + mo (prob. -mō- + o)], M., (*series?*). Hence, *conversation* (continuous series of speech), *talk, intercourse, conversation with* (genitive).

**serō**, sēvi, satus, serere, [√SA, redupl.], 3. v. a., *plant, sow*.

**serō** [abl. of serus], adv., *too late*.

**Sertōrius**, -ī, [sertor(?) + ius], M., (*garland-maker?*), a Roman gentile name. — Esp., *Q. Sertorius*, a partisan of Marius, who held a command in Spain against the party of Sulla from B.C. 80 to B.C. 72.

**servilis**, -e, [servi (as if stem of servus or akin, cf. servio) + lis], adj., *of slaves, of a slave, servile*: **in servilem modum** (*as with slaves, i.e. by torture*); **tumultus** (*the servile war*, the revolt of the slaves under Spartacus in B.C. 73).

**serviō**, -iī (-ivī), -itūrus, -īre, [servi- (as if stem of servus or akin)], 4. v. n., *be a slave* (to some one or something); **rumoribus** (*be*

*blindly guided by, follow*); **bello** (*devote one's self to*).

**servitūs**, -tūtis, [†servitu (servō + tus) + tis, cf. iuventus, sementis], F., *slavery, servitude*.

**Servius**, -ī, [servō + ius], M., a Roman praenomen.

**servō**, -āvī, -ātus, -āre, [servō-], 1. v. a., *watch, guard, keep, preserve*: **praesidia** (*hold, maintain*); **ordines** (*keep*); **fidem** (*keep one's word*).

**servus**, -ī, [unc. root (√SER, bind?) + vus], M., *a slave*.

**sescentī**, see **sexcentī**.

**sēsē**, see **sui**.

**sēsquipedālis**, -e, [†sesquiped- (*a foot and a half*) + alis], adj., *of a foot and a half, eighteen-inch* (beams, etc.).

**Sesuvii**, see **Esvvii**.

**setius**, see **secus**.

**seu**, see **sive**.

**sevērītās**, -tātis, [severō + tas], F., *strictness, harshness*.

**sēvocō**, -āvī, -ātus, -āre, [se (sed) -voco], 1. v. a., *call aside, call out* (aside).

**sēvum** (**sēbum**), [?], N., *tallow*.

**sex** [?], indecl. num. adj., *six*.

**sexāgintā** [sex + unc. term.], indecl. num. adj., *sixty*.

**sexcentī** (ses-), -ae, -a, [sex-centum], num. adj., *six hundred*.

**sexdecim** (sēdecim), [sex-decem], indecl. num. adj., *sixteen*.

**Sextius**, -ī, [sextō + ius], M., a Roman gentile name. — Esp.: 1. *Titus Sextius*, a legatus of Caesar. — 2. *Publius Sextius Baculus*, a centurion in Caesar's army.

**sī** [locative, prob. akin to se], conj., (*in this way, in this case, so, cf. sic*), *if, in case*. — Esp., *to see if, whether*: *id si fieret* (*should this happen, etc.*). — See also **sicubi**.

**sibī**, see **sul**.

**Sibuzātes**, -um, [Celtic], M. pl., a people of Aquitania, near the Pyrenees.

**sic** [si-ce, cf. **hic**], adv., so, in this manner, in such a manner, thus: **sic . . . ut** (so . . . that, so well . . . that); **sic reperiebat** (this). — **sicutī**, as conj., just as, just as if.

**siccitās**, -tātis, [siccō + tas], F., dryness, drought, dry weather. — Plur. in same sense, of different occasions.

**sicubi** [perh. si-†quobi (old form of **ubi**?), but cf. **sic**], conj., if anywhere.

**sicut** (**sicutī**), see **sic**.

**sīdus**, -eris, [√SED + us], N., (position?), a heavenly body.

**Sigambri** (**Sug-**), -ōrum, [Teutonic], M., a German tribe.

**signifer**, -ferī, [signo-fer (√FER + us)], M., a standard-bearer.

**significatiō**, -ōnis, [significā + tio], F., a making of signs, a signal, an intimation, a warning.

**significō**, -āvī, -ātus, -āre, [†significō- (signō- + ficus)], I. v. n., make signs, indicate, make known, spread news, give an intimation, give information: **hac re significari** (this is an indication); **de fuga; dedicationem** (make signs of).

**signum**, -ī, [unc. root + num (N. of -nus)], N., (a device?), a sign, a signal. — Esp., a standard (for military purposes, carried by each body of men, consisting of some device in metal on a pole). — Phrases: **signa convertere** (wheel, change front, face about); **signa inferre** (advance to attack, charge); **conversa signa inferre** (change front and charge); **infestis signis** (for an attack, at charge); **signa ferre**

(move, move on, march); **signa subsequi** (keep the line of march); **signa relinquere** (leave the ranks); **se continere ad signa** (keep the ranks); a **signis discedere** (desert, leave the ranks); **ad signa convenire** (join the army); **ad signa consistere** (rally around the standard); **signa constituere** (halt).

**Silānus**, -ī, [?], M., a Roman family name. — Esp., **Marcus Silānus**, a legatus of Cæsar.

**silentium**, -ī, [silent + ium], N., silence. — **silentiō**, abl., in silence, silently.

**Silius**, -ī, [?], M., a Roman gentile name. — Esp., **Titus Silius**, a military tribune in Cæsar's army.

**silva**, -ae, [?], F., a forest, woods, forests. — Plur. in same sense.

**silvester** (-tris), -tris, -tre, [silva- (as if **silvus**-, cf. **palustris**) + tris], adj., woody, wooded.

**similis**, -e, [†simō- (cf. **simplex**, **semper**, **simitu**) + lis], adj., like, similar.

**similitūdō**, -inis, [simili + tudo], F., likeness, resemblance (to, genitive).

**simul** [N. of **similis**, cf. **facul**], adv., at the same time, as soon as: **simul atque** (as soon as).

**simulācrum**, -ī, [simulā + crum], N., an image.

**simulātiō**, -ōnis, [simulā + tio], F., a pretence, a show.

**simulātus**, -a, -um, p.p. of **simulo**.

**simulō**, -āvī, -ātus, -āre, [simili- (as if, perh. orig., †simulō)], I. v. a., pretend, make a show of (something).

**simulās**, -tātis, [simili- (cf. **simul**) + tas], F., (likeness?, equality?), rivalry.

**sīn** [si-ne], conj., (if not), but if.

**sincērē** [old abl. of *sincerus*], adv., *honestly, truly*.

**sine** [?], prep., *without*.

**singulāris**, -e, [*singulō + aris*], adj., *solitary, single*. Hence, *unique, extraordinary, unparalleled, unequalled, marvellous*.

**singulātīm** (*singill-*), [as if *singulā-* (*singulus*) + *tīm* (acc. of *tis*)], adv., *singly, one by one, individually*.

**singuli**, -ae, -a, [*sim* (in *similis*) + unc. term.], adj., *one at a time, single, each, one by one, several (severally)*. — Often to denote distribution, *one to each*: *singuli singulos* (with verb, *one . . . each*); *singulis legionibus singulos legatos* (*one over each*); *ab singulis legionibus singulos legatos discedere* (*each from his*); *inter singulas legiones* (*between each two, one to each*); *naves singulas Romanis equitibus* (*severally, separately, one to each*); *sevocare singulos* (*individuals, one by one*).

**sinister**, -tra, -trum, [?], adj., *left*: *sub sinistra* (*on the left*).

**sinistrōrsus** [*sinistro-vorsus* (*versus*)], adv., *to the left*.

**sinō**, *sivī*, *situs*, *sinere*, [*√si* (of unc. meaning)], 3. v. a., (*lay down*, cf. **pono**), *leave*. Hence, *permit, allow*.

**sī quandō**, *if ever, whenever*. Cf. **si** and **quando**.

**sī quidem**, *if at least, in so far as, since*. Cf. **si** and **quidem**.

**sī quis**, *if any*. Cf. **si** and **quis**.

**sī quō**, *if anywhere (whither)*. Cf. **si** and **quo**.

**sistō**, see **circumsisto**.

**situs**, -tūs, [*√si + tus*], M., (*a laying, a leaving*), *situation, position*.

**sive, seu**, [*si-ve*], conj., *if either, or if*: *sive . . . sive* (*either . . . or*). **socer**, -crī, [?], M., *a father-in-law*.

**societās**, -tātis, [*sociō + tas*], F., *an alliance*.

**socius**, -ī, [*√SEQU + ius*], M., *a companion, an ally*.

**sōl**, *sōlis*, [?], M., *the sun*. — See also **oriens, occidens, occāsus**.

**sōlācium**, see **solatium**.

**sōlātium** (*sōlāc-*), -ī, [*solatō + ium*], N., *a consolation*.

**soldurius**, -ī, [Teutonic], M., *a retainer*.

**soleō**, *solitus sum, solēre*, [?], 2. v. n., *be wont*.

**sōlertia**, see **sollertia**.

**sōlitūdō**, -inis, [*solō + tudo*], F., *loneliness*. Hence, *a wilderness*.

**sollertia** (*sōler-*), -ae, [*sollert-* (*sollō + ars*, with complete skill, cf. **sollicito**) + *ia*], F., *skill, ingenuity, shrewdness*.

**sollicitātus**, -a, -um, p.p. of **sollicito**.

**sollicitō**, -āvī, -ātus, -āre, [*sollicitō-* (*sollō-citus, entirely roused*)], 1. v. a., *stir up, instigate, make overtures to, tamper with, approach* (with money, etc.), *offer bribes to*.

**sollicitūdō**, -inis, [*√sollicitu-* (stem akin to **sollicitus**) + *do*], F., *anxiety*.

**sōlum**, see **solus**.

**solum**, -ī, [?], N., *the soil, the foundation*: *solum agri* (*the bare ground*); *ab infimo solo* (*from the very bottom*).

**sōlus**, -a, -um, [?], adj., *alone, only*. — **sōlum**, N. as adv., *alone, only*.

**solūtus**, -a, -um, p.p. of **solvo**.

**solvō**, *solvi, solūtus, solvere*, [prob. *se-luo*], 3. v. a., *unbind, loose*. — Esp. with **navis**, *weigh anchor*,

*set sail*. — Also without **navis**, absolutely, *set sail*.

**sonitus**, -tūs, [**soni-** (as stem of **sono**) + **tus**], M., *a sound, noise*.

**Sontiātes**, -um, [Celtic], M. pl., a people of Aquitania.

**sonus**, -ī, [√**SON**+**us**], M., *a sound*.

**soror**, -ōris, [?], F., *a sister*: **soror ex matre** (*a half sister*).

**sors**, **sortis**, [perh. √**SER** (in **sero**) + **tis**, but the orig. sense is unc.], F., *a lot* (for divination).

**spatium**, -ī, [?], N., *space, extent, a space, a distance*. — Transf., *time, space of time, lapse of time*. — Phrases: **quantum fuit diei spatium** (*as much as there was time for*); **intermisso spatio** (*after an interval*); **spatia omnis temporis** (*the whole course of time*).

**speciēs**, -iēi, [√**SPEC** + **ies** (akin to **-ia**)], F., (*a sight, prob. both act. and pass.*). — Passively, *a sight, a show, an appearance*: **summa species earum stantium** (*a perfect appearance of standing trees*).

**spectō**, -āvī, -ātus, -āre, [**spectō-**], I. v. a. and n., *look at, regard, have regard to, lie towards* (of a country).

**speculātor**, -tōris, [**speculā** + **tor**], M., *a spy, a scout*.

**speculātōrius**, -a, -um, [**speculator** + **ius**], adj., (*of a scout*), *scouting, reconnoitring* (**navigia**).

**speculor**, -ātus, -ārī, [**speculō-**], I. v. dep., *spy, reconnoitre*: **speculandi causa** (*as a spy*).

**spērātus**, -a, -um, p.p. of **spero**.

**spērō**, -āvī, -ātus, -āre, [**spes-** (prob. orig. stem of **spes**) with **r** for **s**], I. v. a. and n., *hope, hope for, expect*.

**spēs**, -eī, [?], F., *hope, expectation*: **summam in spem venire** (*have the greatest hope*).

**spīritus**, -tūs, [**spiri-** (as stem of **spiro**) + **tus**], M., *breath*. — Also, *spirit*. Hence, in plur., *pride*.

**spoliō**, -āvī, -ātus, -āre, [**spoliō-**], I. v. a., *despoil, strip*. — Fig., *rob, deprive, despoil*.

**spontis** (gen.), **sponte** (abl.), [prob. akin to **spondeo**], F., only with possessive or (poetic) genitive, *of one's own accord, voluntarily*.

**stabiliō**, -īvī (-īi), -ītus, -īre, [**stabili-**], 4. v. a., *make firm*.

**stabilitās**, -tātis, [**stabili** + **tas**], F., *steadiness, firmness*.

**statim** [acc. of †**statis** (**sta** + **tis**)], adv., (*as one stands, on the spot*), *at once, forthwith, immediately*.

**statiō**, ōnis, [apparently √**STA** + **tio**, prob. †**stati** + **o**, wh. the common **-tio** used as ending without regard to its origin], F., (*a standing*), *a position, a post, a picket*: **in statione** (*on guard*).

**statuō**, -uī, -ūtus, -uere, [**statu-**], 3. v. a., *set up*. Hence, *establish, resolve upon, determine, consider* (make up one's mind), *take measures*. — Euphemistic for, *punish* (**de eo causa cognita**).

**statūra**, -ae, [**statu** + **ra**, F. of **-rus**], F., (*a standing*), *stature, size*.

**status**, -tūs, [√**STA** + **tus**], M., (*a standing*), *a position, a condition, a state*.

**stimulus**, -ī, [†**stigmō-** (√**STIG** + **mus**) + **lus**], M., *a goad, a spur*. — As name of a calthrop or instrument of defence, "*spurs*."

**stīpendiārius**, -a, -um, [**stīpendiō** + **arius**], adj., *tributary, under tribute, subject to tribute*.

**stīpendium**, -ī, [**stīpi-** and stem akin to **pendo** (perh. †**pendus**, cf. **pendulus**) + **ium**], N., *a tribute*.

**stipes**, stīpitis, [?], M., a trunk (of a tree).

**stirps**, stirpis, [?], M. and F., a stock. — Fig., a race: stirpem hominum interfici (men to be killed root and branch).

**stō**, stētī, stātūrus, stāre, [√STA], I. v. n., stand: decreto (stand by, abide by).

**strāmentum**, -ī, [√STRA (form of root of **sterno**) + **mentum**], N., (something strewn), straw, thatch. — Also plur., saddle-cloths.

**streptus**, -tūs, [strepī- (as stem of **strepo**) + **tus**], M., a noise, a confused din.

**structūra**, -ae, [structu + ra (cf. **figura**)], F., a structure: aerariae structurae (galleries, a doubtful reading in VI. 34).

**studeō**, studuī, no p.p., studēre, [†studō- (or †studa-), cf. **studium**], 2. v. n., be eager for, be devoted to, pay attention to, attend to, desire (a thing in the dat.).

**studiōsē** [old abl. of **studiosus**], adv., eagerly.

**studium**, -ī, [prob. †studō + **ium**, cf. **studeo**], N., eagerness, zeal, devotion, fondness (for a thing), enthusiasm. Hence, a pursuit (to which one is devoted), an occupation.

**stultitia**, -ae, [stultō + **tia**], F., folly.

**sub** (in comp. **subs**), [unc. case, prob. abl. (cf. **subs**) akin to **super**], adv. (in comp.) and prep.:

a. With abl. (of rest in a place), under: sub oculis (before the eyes). — Also, just by: sub monte (at the foot of); sub sinistra (at the left); sub vallo (just under the wall).

b. With acc. (of motion towards a place), under, close to. — Of time, just at, just before: sub vesperum.

c. In comp., under, up (from under), away (from beneath), secretly (underhand), in succession, a little, slightly.

**subāctus**, -a, -um, p.p. of **subigo**. **subc-**, see **succ-**.

**subdolus**, -a, -um, [sub-dolus], adj., cunning, wily.

**subdūcō**, -dūxī, -ductus, -ducere, [sub-ducō], 3. v. a., draw up, lead up: naves (beach, draw up).

**subductiō**, -ōnis, [sub-†ductio, cf. **subduco**], F., a drawing up, a beaching (of ships).

**subductus**, -a, -um, p.p. of **subduco**.

**subeō**, -iī, -itus, -īre, [sub-eo], irr. v. a., go under, undergo, encounter, come up.

**subf-**, see **suff-**.

**sūbiciō** (**subji-**), -jēcī, -jectus, -icere, [sub-jacio], 3. v. a., throw under, place below, place under, subject, expose to. — Also, throw up.

**subigō**, -ēgī, -āctus, -igere, [sub-ago], 3. v. a., bring under, subject.

**subitō**, see **subitus**.

**subitus**, -a, -um, [p.p. of **subeo**], adj., (coming up secretly from under), sudden, suddenly (as if adv. taken with the verb), quick, hasty. — **subitō**, abl. as adv., suddenly, of a sudden.

**subjectus**, -a, -um, p.p. of **subicio**.

**subjiciō**, see **subicio**.

**sublātus**, -a, -um, [sub-(t)latus], p.p. of **tollo**.

**sublevātus**, -a, -um, p.p. of **sublevo**.

**sublevō**, -āvī, -ātus, -āre, [sublevo], I. v. a., lighten up, lighten, raise, raise up, assist, render assistance. — With reflexive, rise up. — **sublevātus**, p.p., supporting one's self.

**sublica**, -ae, [?], F., a pile.

**subluō**, no perf., -lūtus, -luere,

[sub-luo], 3. v. a., *wash underneath*, *wash*: *flumen collis radices*.

**subministrō**, -āvi, -ātus, -āre, [sub-ministro], 1. v. a., *supply* (as needed), *furnish* (from time to time).

**submittō** (sum-), -mīsi, -missus, -mittere, [sub-mitto], 3. v. a., *send up*, *send to one's assistance*, *send as reinforcements*, *send* (as help), *reinforce*.

**submōtus**, -a, -um, p.p. of **submoveo**.

**submoveō** (sum-), -mōvī, -mōtus, -movēre, [sub-moveo], 2. v. a., *drive off*, *dislodge*.

**subp-**, see **supp-**.

**subruō**, -ruī, -rutus, -ruere, [sub-ruo], 3. v. a., *dig under*, *undermine*.

**subsequor**, -secūtus, -sequī, [sub-sequor], 3. v. dep., *follow up*, *follow on*, *follow*, *succeed to*.

**subsidium**, -ī, [sub-†sedium (√SED + ium)], N., (*a sitting in reserve*), *a reserve*, *a reinforcement*, *help*, *relief*, *support*, *assistance*: **subsidio mittere** (*send assistance*); **subsidium ferre** (*rescue*).

**subsīdō**, -sēdī, -sessūrus, -sīdere, [sub-sido], 3. v. n., *sit down*, *remain behind*.

**subsistō**, -stiti, no p.p., -sistere, [sub-sisto], 3. v. n., *stop behind*, *halt*, *make a stand*: **ancorae** (*hold*).

**subsum**, -fui, -futūrus, -esse, [sub-sum], irr. v. n., *be under*, *be near*, *be close by* (a certain distance off), *be near at hand*, *approach*.

**subtrahō**, -trāxī, -trāctus, -trahere, [sub-traho], 3. v. a., *take away* (underneath), *carry away*, *take away* (generally).

**subvectiō**, -ōnis, [sub-vectio, cf. **subveho**], F., *bringing up*, *transportation*.

**subvehō**, -vēxī, -vectus, -vehere, [sub-veho], 3. v. a., *bring up*.

**subveniō**, -vēnī, -ventūrus, -venire, [sub-venio], 4. v. n., *come under*, *come to the support of*, *come to the assistance of*.

**succēdō**, -cēssi, -cēssūrus, -cēdere, [sub-cedo], 3. v. n., *come up*, *advance*, *come in place of*, *succeed to*, *take the place of*, *come next*.—Also, *be successful*, *prosper*.

**succendō**, -cendi, -cēsus, -cendere, [sub-†cando (cf. **candeo**)], 3. v. a., *set on fire* (as if beneath).

**succēnsus**, -a, -um, p.p. of **succendo**.

**succēssus**, -ūs, [sub-cessus (cf. **succedo**)], M., *a coming up*, *an advance*.

**succīdō**, -cīdī, -cīsus, -cīdere, [sub-caedo], 3. v. a., *cut under*, *cut down*.

**succīsus**, -a, -um, p.p. of **succido**.

**succumbō**, -cubūi, -cubitūrus, -cumbere, [sub-cumbo], 3. v. n., *lie down* (under), *give way*, *succumb*.

**succurrō**, -curri, -cursūrus, -currere, [sub-curro], 3. v. n., *rush to support*, *rush to one's rescue*.

**sudis**, -is, [?], F., *a stake*.

**sūdor**, -ōris, [√SUD + or], M., *sweat*. Hence, *toil*.

**Suēbī**, see **Suēvi**.

**Suessiōnes**, -um, [Celtic], M. pl., a tribe of the Belgians between the Marne and the Isère. Their town Noviodunum was later called from them *Soissons*.

**Suēvī** (**Suēbī**), -ōrum, [Teutonic], M. plur., name of the tribes inhabiting a large part of Germany, *Swabians*.

**Suēvus**, -a, -um, [see **Suevi**], adj., *Swabians*.—As subst., a *Swa-*



bian (man or woman). — Plur., see above.

**sufficiō**, -fēcī, -fectus, -ficere, [sub-facio], 3. v. a., *make in place of, supply the place of*. Hence, *suffice, be sufficient, be adequate*.

**suffodiō**, -fōdī, -fossus, -fodere, [sub-fodio], 3. v. a., *dig under, stab (underneath)*.

**suffossus**, -a, -um, p.p. of **suffodio**.

**suffrāgium**, -ī, [sub-†fragium, i.e. prob. suffragō + ium (cf. **suffragor** and **suffringo**)], N., (*a pastern bone, cf. suffrago*; or a *potsherd, cf. Gr. ὑστρακον*; either used as a ballot), *a ballot, vote*.

**suggestus**, -tūs, [sub-gestus, cf. **suggerō**], M., (*earth brought up*), *a raised mound, a tribunal* (whence the Roman commander addressed his troops).

**suī** (prop. gen. N. of **suus**), **sibi** sē, [√SVA], pron. reflexive, *himself*, etc. — Often to be translated by the personal, *he, etc.*, also *each other*. — Esp.: *inter se* (*from, with, by, etc., each other*); *inter sese dant* (*give each other, exchange*); *per se* (*of himself, etc., without outside influence or excitement*); *ipse per se* (*in and of himself*).

**Sulla**, ae, [?], M., a Roman family name. — Esp., *Lucius Cornelius Sulla*, the great partisan of the nobility and opponent of Marius, called the Dictator Sulla.

**Sulpicius**, -ī, [?], M., a Roman gentile name. — Esp.: 1. *Sulpicius Rufus*, a legatus of Cæsar. — 2. *Servius Sulpicius Galba*, a legatus of Cæsar.

**sum**, fui, futūrus, esse, [√AS, cf. *am, is*], irr. v. n., *be (exist)*. — Also, with weakened force, *be* (as a mere

copula). — Phrases: *erant duo itinera* (*there were*); *sibi esse in animo* (*that he had in mind, intended*); *pars quae est ad Hispaniam* (*lies*); *eorum est* (*they have*); *multum sunt in venationibus* (*much engaged*).

**summa**, -ae, [F. of **summus** as noun], F., (*the top*), *the sum, the total, the main part*: *summa omnium rerum* (*the whole amount*); *belli* (*the general management, the chief control*); *imperi* (*the chief command*); *imperi bellique administrandi* (*the chief management, etc.*); *rerum consiliorumque* (*chief control*); *summa exercitus* (*the main body, etc.*).

**sumministrō**, see **subministro**.

**summittō**, see **submitto**.

**summoveō**, see **submoveo**.

**summus**, see **superus**.

**sūmō**, sūmpsi, sūmptus, -sūmere, [sub-emo (*take*)], 3. v. a., *take away, take, get, assume*: *supplicium* (*inflict, cf. capere*); *laborem* (*spend*).

**sūmptuōsus**, -a, -um, [sumptu + osus], adj., *expensive, costly*.

**sūmptus**, -tūs, [sub-†emptus, cf. **sumo**], M., (*a taking out of the stock on hand*), *expense*.

**superātus**, -a, -um, p.p. of **supero**.

**superbē** [old abl. of **superbus**], adv., *haughtily, arrogantly, with arrogance*.

**superior**, see **superus**.

**superō**, -āvī, -ātus, -āre, [superō-], 1. v. a. and n., *overtop*. Hence, *get the upper hand of, overcome, conquer, defeat, be superior to, prevail, overmatch, survive (vita)*.

**supersedeō**, -sēdī, -sessūrus, -sedēre, [super-sedeo], 2. v. n., *sit*

above. Hence, *be above, decline, refrain from.*

**supersum**, -fuī, -futūrus, -esse, [super-sum], irr. v. n., *be over and above, remain, survive.*

**superus**, -a, -um, [†supe- (stem akin to **sub**, perh. same) + **rus** (cf. **inferus**)], *higher, being above*: **de supero** (as subst., *from above*). — Compar., **superior**, *higher, upper, preceding* (of time), *past, before, superior*. — Superl., **suprēmus** [supra-(?) + **imus**(?)], *highest*. — Also, **summus** [sup + **mus**], *highest, the highest part of, the top of*. — Fig., *greatest, most important, very great, most perfect, perfect, supreme, most violent*: **ab summo** (*from the top*); **summis copiis** (*with all the forces, in force, with all one's might*).

**suppetō**, -petivī, -petitūrus, -petere, [sub-peto], 3. v. n., (?), but cf. **sufficio** and **subvenio**), *be on hand, be supplied, be to be found*.

**supplēmentum**, -ī, [supplē- (as stem of **suppleo**) + **mentum**], N., *a supply (to fill up), a reinforcement*.

**supplex**, -icis, [sub-†plex (√PLIC as stem, cf. **duplex**)], C., *a suppliant*.

**supplicātiō**, -ōnis, [supplicā + **tio**], F., *a supplication*. — Esp., *a thanksgiving* (prayer to the gods upon any signal success, decreed by the senate).

**suppliciter** [supplici- (as stem of **supplex**) + **ter**], adv., *in the guise of suppliants, as suppliants*.

**supplicium**, -ī, [supplic- (stem of **supplex**) + **ium**], N., (*a kneeling*). Hence, *a supplication*. — Also, esp., *a punishment* (usually of death).

**supportō**, -āvi, -ātus, -āre, [sub-

porto], 1. v. a., *bring up, supply, furnish*.

**suprā** [instr. (?) of **superus**], adv. and prep., *above, before*.

**susceptus**, -a, -um, p.p. of **suscipio**.

**suscipiō**, -cēpi, -ceptus, -cipere, [subs-capio], 3. v. a., *take up, take upon one's self (sibi), undertake, engage in, undergo*.

**suspectus**, -a, -um, p.p. of **suspicio**.

**suspiciātus**, -a, -um, p.p. of **suspicio**.

**suspiciō**, -spēxi, -spectus, -spicere, [sub-specio], 3. v. a. and n., *look up, look up at, look askance at*. Hence, *suspect*: **suspecta nobis** (*an object of suspicion to us*).

**suspiciō** (-spitiō), -ōnis, [sub-†specio, cf. **suspicio**], F., *suspicion, an imputation (timoris), an indication*: **dabat . . . fugae** (*endeavored to excite a suspicion*); **neque abest suspicio** (*and there is a suspicion abroad, not without suspicion*).

**suspīcor**, -ātus, -ārī, [†suspicio (cf. **auspex**)], 1. v. dep., *suspect*.

**sustentātus**, -a, -um, p.p. of **sustento**.

**sustentō**, -āvi, -ātus, -āre, [subs-tento (cf. **sustineo**)], 1. v. a. and n., *sustain, hold out*: **bella** (*hold out against*); **aegre is dies sustentatur** (*with difficulty they hold out for that day*); **pecore famem** (*keep from starvation by means of, etc.*).

**sustineō**, -tinuī, -tentus, -tinēre, [subs-teneo], 2. v. a. and n., *hold up under, withstand, endure, hold out, bear, stop, rein in* (horses); **sustinere se** (*stand up*).

**suus**, -a, -um, [√SVA + **ius**, cf. **se**], adj. pron. (reflexive, referring

back to subject), *his, hers, its, theirs*, etc. — Sometimes emphatic, *his own*, etc. — Often without subst., *sui, their* (*his*) *men, countrymen, their friends; sua, their* (*his*) *possessions, their property: se suaque omnia* (*themselves and all they had*).

## T.

**T.**, abbrev. for **Titus**.

**tabernāculum**, -ī, [**taberna** + **culum**], N., (*a hut of boards*), *a tent*.

**tabula**, -ae, [†**tabō-** (√**TA** + **bus**?) + **lā**], F., *a board*. Hence, *a record* (written on a board covered with wax), *a document*.

**tabulātus**, -a, -um, [**tabulā-** (as if stem of †**tabulo**) + **tus**], adj., *made with boards*. — **tabulātum**, N., *a flooring, a storey*.

**taceō**, tacuī, tacitus, tacēre, [†**tacō-** (√**TAC** + **us**)], 2. v. a. and n., *be silent, be silent about, keep secret, conceal, say nothing about*. — **tacitus**, p.p. as adj., *silent, in silence*.

**tacitus**, -a, -um, p.p. of **taceo**.

**tālea**, -ae, [perh. akin to **tālus**], F., *a rod, a bar*.

**tālis**, -e, [√**TA** + **alis**], adj. pron., *such, so great*.

**tam** [unc. case √**TA** (cf. **quam, nam**)], adv., *so* (as indicated in the context), *so much*.

**tamen** [unc. case-form of √**TA** (locat.?, cf. Sk. **tasmin**?)], adv., (introducing a thought opposed to some preceding concession expressed or implied), *yet, nevertheless, still, however, for all that, notwithstanding, after all, at least*.

**Tamesis**, -is, [Celtic], M., *the Thames*.

**tametsī** [**tamen** (or **tam**?) - **etsi**], adv., (*still although*, anticipating the thought to which **tamen** properly belongs), *although*.

**tandem** [**tam-dem**, cf. **idem**], adv., (*just so, even so*?), *at last*. — In questions, to add emphasis, *pray, tell me*, or translated only by emphasis.

**tangō**, tetigī, tactus, tangere, [√**TAG**], 3. v. a., *touch, border on*.

**tantopere**, see **opus**.

**tantulus**, -a, -um, [**tantō** + **lus**], adj., *so small, so little, so trifling*.

**tantum**, see **tantus**.

**tantummodo** [**tantum modo**], adv., (*so much only*), *only, merely, only just*.

**tantundem** (**tantum-dem**, cf. **idem**), adv., *just so far*.

**tantus**, -a, -um, [prob. √**TA** + **VANT** + **us**], adj., *so much, so great, such* (of magnitude): *tanti est* (*is of so much weight*); *tanta exiguitas temporis* (*so brief time*). — Esp., *so much* (and no more), *only so much*: **tantum progredi** (*so far as*). — **tantum**, N. as adv., *only, merely*.

**Tarbellī**, -ōrum, [Celtic], M. pl., *a tribe of Aquitania*.

**tardātus**, -a, -um, p.p. of **tardō**.

**tardē** [old abl. of **tardus**], adv., *slowly, tardily, with delay*.

**tardō**, -āvī, -ātus, -āre, [**tardō-**], 1. v. a., *retard, check, hinder*: **Romanos ad insequendum** (*hinder from pursuing, retard the pursuit of, etc.*).

**tardus**, -a, -um, [?], adj., *slow*.

**Tarusātes**, -um, [Celtic], M. pl., *a tribe of Aquitania*.

**Tasgetius**, -ī, [Celtic], M., *a prince of the Carnutes*.

**taurus**, -ī, [perh. √**STAV-** + **rus**, akin to *steer*], M., *a bull*.

**Taximagulus**, -ī, [Celtic], M., a prince of Britain.

**taxus**, -ī, [?], F., a *yeew-tree*. — Also, *yeew* (the berries used as poison).

**Tectosages**, -um, [Celtic], M. pl., a branch of the **Volcae**, which see.

**tectum**, -ī, [N. p.p. of **tego**], N., a *roof, a house*.

**tectus**, -a, -um, p.p. of **tego**.

**tegimentum** (**tegu-**), -ī, [tegi- (stem of **tego**) + **mentum**], N., a *covering*.

**tegō**, **tēxī**, **tectus**, **tegere**, [√TEG], 3. v. a., *cover, thatch, hide*.

**tegmentum**, see **tegimentum**.

**tēlum**, -ī, [?], N., a *weapon* (of offence), a *missile, a javelin*.

**temerārius**, -a, -um, [†**temerō** + **arius**], adj., *reckless, rash, hasty*.

**temerē** [old abl. of †**temerus**], adv., *blindly, without reason, without cause*. Hence, *recklessly, hastily*.

**temeritās**, -tātis, [†**temerō**- (perhaps akin to **temulentus**) + **tas**], F., *blindness, thoughtlessness, recklessness, heedlessness, hasty temper*.

**tēmō**, -ōnis, [?], M., a *pole* (of a wagon, etc.).

**temperantia**, -ae, [temperant- + **ia**], F., *self-control, prudence*.

**temperātus**, -a, -um, p.p. of **tempero**, which see.

**temperō**, -āvi, -ātus, -āre, [temper- (stem of **tempus**)], 1. v. a., (*divide*), *mix properly*. Hence, *control, control one's self, refrain, restrain one's self from* (**quin**). — Esp., **temperātus**, -a, -um, p.p. as adj., *temperate, mild*.

**tempestās**, -tātis, [tempes- (stem of **tempus**) + **tas**], F., a *season, weather*. — Esp., *bad weather, a storm, a tempest*.

**temptō** (**tentō**), -āvi, -ātus, -āre, [tentō-, p.p. of **teneo**], 1. v. a., *handle*. Hence, *try*: **iter** (*try to force*).

**tempus**, -oris, [√TEM (*cut*, with root determinative or accidental p) + **us**], N., (*a cutting*). — Esp., a *division of time, a time, time* (in general), a *season, an occasion, an emergency, a crisis*: **tam necessario tempore** (*at so critical a moment*); **omni tempore** (*at all times, always*); **in reliquum tempus** (*for the future*); **uno tempore** (*at once*); **tempore exclusus** (*cut off by the want of time*).

**Tenctēri** (-thēri), -ōrum, [Teutonic], M. plur., a branch of the **Usi-petes**, which see.

**tendō**, **tetendī**, **tēnsus** (**tentus**), **tendere**, [√TEN + **do** (of unc. origin)], 3. v. a., *stretch, stretch out*. — Esp., *stretch a tent, encamp*.

**tenebrae**, -ārum, [?], perh. akin to **temere**], F. plur., *darkness*.

**teneō**, **tenuī**, **tentus**, **tenēre**, [†**tenō**- (√TEN + **us**)], 2. v. a., *hold, retain, keep, possess, occupy*: **circuitus milia** (*occupy, extend*). — Also, *restrain, detain*: **tenere obsidibus** (*bind*); **se tenere** (*remain*).

**tener**, -era, -erum, [√TEN + **rus**], adj., (*stretched, thin*), *delicate, tender, young*.

**tentō**, see **temptō**.

**tenuis**, -e, [√TEN + **us**, with accidental **i**, cf. **gravis**], adj., *thin, delicate, feeble, meagre, poor*.

**tenuitās**, -tātis, [**tenui** + **tas**], F., *thinness, poverty*.

**tenuiter** [**tenui** + **ter**], adv., *thinly, slightly*.

**ter** [prob. mutilated case of **tres**], adv., *three times*.

**teres**, -etis, [tere- (as stem of

tero) + tis], adj., (*rubbed*), *smooth and round, tapering*.

**tergum**, -ī, [?], N., *the back*: *terga vertere* (*turn and fly*); *a tergo* (*in the rear*).

**terni**, -ae, -a, [tri + nus], adj., *three each, three at once*.

**terra**, -ae, [√TERS(?) + a, cf. **torreo**], F., (*the dry land*), *the earth, the land*.—Also, *a land, a region*.—Also, *the ground*.—Plur., *the world*.

**Terrasidius**, -ī, [Celtic], M., a Roman gentile (?) name.—Esp., *Titus Terrasidius*, a military tribune in Cæsar's army.

**terrēnus**, -a, -um, [terra- (as if terrē) + nus], adj., *of earth*.

**terreō**, terrui, territus, terrēre, [†terrō- (?)], 2. v. a., *frighten, alarm*.

**territō**, -āvi, -ātus, -āre, [territō-], 1. v. a., *frighten*: *metu* (*alarm with fears, keep alarmed*).

**terror**, -ōris, [√TERR + or], M., *fright, alarm, terror, dread, panic*.

**tertius**, -a, -um, [prob. tri + tius], adj., *third* (in order); *pars* (*the third part*).

**testāmentum**, -ī, [testā + mentum], N., *a will*.

**testimōnium**, -ī, [testi + monium], N., *proof, evidence*.

**testis**, -is, [?], C., *a witness*.

**testūdō**, -inis, [†testu- (akin to testa) + do], F., *a tortoise*.—Esp., *a covered column* (made by lapping the shields of one rank over those of another).—Also, *a shelter* (a small roof over attacking soldiers).

**Teutomatus**, -ī, [Celtic], M., a king of the Nitrobriges.

**Teutones**, -um, (**Teutoni**, -ōrum), [Teutonic], M. plur., a great German people in Jutland who overran Gaul

in B.C. 113 along with the Cimbri. They were defeated by Marius in B.C. 102 at Aquæ Sextiæ (*Aix*).

**tignum**, -ī, [?], N., *a log, a timber*.

**Tigurini**, -ōrum, [Celtic], M. pl., a canton or division of the Helvetii.

**timeō**, -uī, no sup., -ēre, [†timō- (cf. **timidus**)], 2. v. a. and n., *be afraid, fear*.—With dat., *be anxious for, be anxious about*: *nihil* (*have nothing to fear*).

**timidē** [old abl. of **timidus**], adv., *with timidity*: *non timide* (*fearlessly*).

**timidus**, -a, -um, [†timō- (cf. **timeo**)], adj., *cowardly, frightened, timid*.

**timor**, -ōris, [tim- (as root of **timeo**) + or], M., *alarm, fear*.

**Titurius**, -ī, [?], M., a Roman gentile name.—Esp., *Quintus Titurius Sabinus*, a legatus of Cæsar.

**Titus**, -ī, [?], M., a Roman prænomen.

**tolerō**, -āvi, -ātus, -āre, [†toler- (√TOL + us)], 1. v. a. and n., (*raise up*), *bear, endure, hold out*: *famem* (*keep from starvation*).

**tollō**, sustulī, sublātus, tollere, [√TOL (with YA)], 3. v. a., *raise, carry, carry off*. Hence, *remove, take away, destroy*: *colloquium* (*break off*).—Esp., *sublātus*, -a, -um, p.p., *elated*.

**Tolōsa**, -ae, [Celtic], F., *Toulouse*, a city of the Volcæ Tectosages.

**Tolōsātes**, -um, [Tolosa + tis], M. plur., *the people of Toulouse*.

**tormentum**, -ī, [√TORQU + mentum], N., (*means of twisting*), *torture*.—Also, *an engine* (for throwing missiles by twisted ropes). Hence, *a shot from an engine, a missile*.

**torreō**, torruī, tostus, torrēre,

[**torrō-** (cf. **torrus**, *firebrand*)], 2. v. a., *scorch*.

**tot** [ $\sqrt{\text{TA}} + \text{ti}$ ], indecl. adj., *so many*.

**totidem** [**toti** + **dem**], indecl. adj., *just as many, as many, the same number*.

**tōtus**, -a, -um, [ $\sqrt{\text{TA}} + \text{tus}$ ], adj., *the whole, the whole of, all, entire*. — Often translated by an adverb, *entirely, throughout*.

**trabs** (**trabēs**), **trabis**, [?], F., *a beam*.

**trāctus**, -a, -um, p.p. of **traho**.

**trādītus**, -a, -um, p.p. of **trado**.

**trādō**, -didī, -ditus, -dere, [**trans-**do], 3. v. a., *hand over, give up, give over, deliver up, surrender*. — Also, *pass along, hand down, teach, communicate*.

**trādūcō**, see **trānsdūcō**.

**trāgula**, -ae, [?], F., *a javelin* (of a large, heavy kind, used by the Gauls).

**trahō**, trāxī, trāctus, trahere, [ $\sqrt{\text{TRAH}}$  (for †**TRAGH**)], 3. v. a., *drag, drag along, drag in, draw in*.

**trāciō** (**trājiciō**), -jēcī, -jectus, -icere, [**trans-jacio**], 3. v. a., *throw across, throw through, transfix, pierce*.

**trājectus**, -tūs, [**trans-jactus**, cf. **traicio**], M., (*a throwing across*), *a passage, a route*.

**trājiciō**, see **trāciō**.

**trānō**, -āvī, -ātus, -āre, [**trans-**no], 1. v. a. and n., *swim across*.

**tranquillitās**, -tātis, [**tranquillō** + **tas**], F., *stillness, calm*.

**trāns** [?, akin to **teminus**, **tebra**], adv. (in comp.) and prep., *across, over*. Hence, *on the other side of*. — In comp., *over, across, through*.

**Trānsalpinus**, -a, -um, [**trans-**

**Alpes** + **inus**], adj., *Transalpine* (lying beyond the Alps from Rome).

**trānsceñdō**, -scendī, -scēnsūrus, -scendere, [**trans-scando**], 3. v. n., *climb across, board* (ships).

**trānsdūcō**, -dūxī, -dūctus, -dūcere, [**trans-duco**], 3. v. a., *lead over* (with two accusatives), *lead across, bring over, lead through, transport, draw over, win over, transfer, lead* (along).

**trānsēō**, -iī, -itus, -īre, [**trans-eo**], irr. v. a. and n., *go across, cross, pass over, go over, pass through, pass, migrate, pass by*.

**trānsferō**, -tulī, -lātus, -ferre, [**trans-fero**], irr. v. a., *carry over, transfer, change the place of*: **ad se bellum** (*direct against, transferring from somewhere else*).

**trānsfigō**, -fixī, -fixus, -figere, [**trans-figo**], 3. v. a., *pierce through*.

**trānsfodiō**, -fōdī, -fossus, -fodere, [**trans-fodio**], 3. v. a., *dig through*. — Also, *pierce through, wound* (by stabbing).

**trānsgridior**, -gressus, -gredi, [**trans-gridior**], 3. v. dep., *step across, step over, cross*.

**trānsgressus**, -a, -um, p.p. of **transgridior**.

**trānsiciō**, see **trāciō**.

**trānsitus**, -tūs, [**trans-itus**, cf. **transeo**], M., *a crossing*: **difficili transitu** (*of difficult passage, difficult to cross*).

**trānslātus**, -a, -um, p.p. of **trānsferō**.

**trānsmarinus**, -a, -um, [**trans-**mare + **inus**], adj., *foreign*.

**trānsmissus**, -ūs, [**trans-missus**, cf. **transmitto**], M., *a crossing, a distance across*: **pari spatio transmissus** (*with a passage of the same length*).

**trānsmisus**, -a, -um, p.p. of **transmitto**.

**trānsmittō**, -mīsī, -missus, -mittere, [trans-mitto], 3. v. a., *send over*.

**trānsportātus**, -a, -um, p.p. of **transporto**.

**trānsportō**, -āvī, -ātus, -āre, [trans-porto], 1. v. a., *bring over* (with two accusatives), *transport, carry over*: **militēs navibus transportari** (*were crossing, being taken over*).

**Trānsrhēnānus**, -a, -um, [trans-Rhenum + anus], adj., *living across the Rhine*. — Plur. as subst., *the people across the Rhine*.

**trānstrum**, -ī, [trans (trant-?) + trum], N., *a thwart*.

**trānsversus**, -a, -um, [p.p. of **transverto**], as adj., *across, athwart*.

**Trebius**, -ī, [?], M., a Roman gentile name. — Esp., *Marcus Trebius Gallus*, a military tribune in Cæsar's army.

**Trebōnius**, -ī, [?], M., a Roman gentile name. — Esp., *Caius Trebonius*: 1, a Roman knight; 2, a legatus in Cæsar's army.

**trecentī**, -ae, -a, [tri-centum], num. adj., *three hundred*.

**tredecim** [tres-decem], indecl. num. adj., *thirteen*.

**trepidō**, -āvī, -āturus, -āre, [trepidō-], 1. v. n., *bustle about, hurry*: **totis trepidatur castris** (*there is a bustle throughout the camp*).

**trēs**, tria, gen. **trium**, [stem tri-], num. adj., *three*.

**Trēverī** (-virī), -ōrum, [Celtic], M. plur., a people in Gaul, originally German, on the Moselle.

**Trēvir**, -irī, [sing. of **Treveri**], M., *one of the Treveri*.

**Tribōces**, -um (-ī, -ōrum), [Cel-

tic], M. plur., a German tribe on the Rhine, about Strasburg.

**tribūnus**, -ī, [tribu-nus], M., (*a chief of a tribe*). With or without **plebis**, a *tribune* (one of several magistrates elected in the assembly of the plebs voting by tribes, to watch over the interests of the commons). — With **militum** or **militaris**, a *tribune of the soldiers, a military tribune* (one of six officers of each legion who had charge of the internal administration of the legion, and were also employed in various staff duties by the commander).

**tribuō**, -uī, -ūtus, -uere, [tribu-], 3. v. a., (*distribute by tribes*), *distribute*. Hence, *grant, render, assign, attribute*: **tantum dignitatis** (*pay such respect*); **magnopere virtuti** (*attribute it so very much to valor*); **reipublicae** (*grant out of regard to*); **plus libertati** (*have more regard for*).

**tribūtum**, -ī, [N. p.p. of **tribuo**], N., *a tribute*.

**triduum**, -ī, [tri + stem akin to **dies**, cf. **biduum**], N., *three days' time, three days*.

**triennium**, -ī, [trienni (tri-annus) + ium], N., *three years*.

**trigintā**, indecl., *thirty*.

**trinī**, -ae, -a, [tri + nus], adj., *three each, three sets of, three* (of things in sets).

**Trinobantes**, -um, [Celtic], M. plur., a people of southern Britain, in the region of Colchester.

**tripartitus** (**tripert-**), -a, -um, [tri-partitus, p.p. of **partio**], adj., *divided in three*. — Esp., **tripartitō**, abl. as adv., *in three divisions*.

**triplex**, -icis, [tri-plex (√PLIC as stem)], adj., *threefold*: **acies** (*in three divisions, or lines*).

**triquetrus**, -a, -um, [tri+quatrus(quattuor), cf. "three-square"], adj., *three-cornered, triangular*.

**tristis**, -e, [unc. root + tis], adj., *sad, gloomy, dejected*.

**tristitia**, -ae, [tristi + tia], F., *sadness, a gloomy state (of mind)*.

**truncus**, -ī, [?], M., *a trunk*.

**tū**, tuī, [√TVA], plur. vōs [√VA], pron. 2d person, *you (sing.), you (plur.)*.

**tuba**, -ae, [?], F., *a trumpet (a straight instrument for infantry)*.

**tueor**, tūtus (tuitus), tuērī, [?], 2. v. dep., *watch, guard, protect*. See also **tūtus**.

**Tulingī**, -ōrum, [Teutonic], M. plur., *a German tribe*.

**Tullius**, -ī, [Tullo + ius], M., a Roman gentile name. — Esp., *Quintus Tullius Cicero*, see **Cicero**.

**Tullus**, -ī, [?], M., a Roman family name. — Esp., *Caius Volcatius Tullus*, a young man in Caesar's suite.

**tum** [prob. acc. of √TA], adv., *then (at a time indicated by the context), at this time: cum . . . tum*, see **cum**; **tum vero** (*then, with emphasis, of the decisive point of a narrative*); **tum maxime** (*just then, but especially*).

**tumultuor**, -ātus, -ārī, [tumultu-], 1. v. dep., *make an uproar*. — As impersonal, *there is an uproar*.

**tumultuōsē** [old abl. of tumultuosus], adv., *with disorder, noisily*.

**tumultus**, -tūs, [tumulō- (perh. reduced) + tus], M., (*a swelling, an uprising?*), *an uproar, confusion, a commotion*. — Esp., *an uprising, a commotion (of revolt, or a war not regularly declared): servilis (the servile war, see servilis)*.

**tumulus**, -ī, [†tumō-(wh. tumeo) + lus], M., (*a swelling?*), *a hill, a mound*.

**tunc** [tun-ee, cf. hic], adj., *just then, then*.

**turma**, -ae, [√TUR (cf. turba, turbo) + ma], F., (*a throng?*), *a squadron (of horse, consisting of thirty men)*.

**Turones**, -um (-ī, -ōrum), [Celtic], M. plur., *a tribe of Gaul on the Loire. Their city became afterwards Tours*.

**turpis**, -e, [?], adj., *ugly (in appearance)*. Hence, *unbecoming, disgraceful, base*.

**turpiter** [turpi + ter], adv., *dishonorably: turpiter factum (an inglorious deed)*.

**turpitūdō**, -inis, [turpi + tudo], F., *baseness*. Hence, *disgrace*.

**turris**, -is, [?], F., *a tower*.

**tūtō**, see **tūtus**.

**tūtus**, -a, -um, [p.p. of tueor], as adj., *protected, safe, secure: victis nihil tutum (no safety for the conquered)*. — **tūtō**, abl. as adv., *in safety, safely*.

**tuus**, -a, -um, [√TVA + ius], adj. pron., *your, yours*.

## U.

**ubi** [supposed to be quō + bi, dat. of quō-], adv., *where, in which: ibi ubi (in the place where)*. — Also, of time, *when: ubi primum (as soon as)*.

**ubicumque** [ubi-cumque (cum + que, cf. quisque)], adv., *wherever, whenever*.

**Ubiī**, -ōrum, [Teutonic], M. plur., *a German tribe on the Rhine, opposite Cologne, near which city they were afterwards settled*.



**ubique** [ubi-que, cf. quisque], adv., *everywhere*.

**ulciscor**, ultus, ulciscī, [?], 3. v. dep., *punish* (an injury, or the doer), *avenge* (an injury).

**ūllus**, -a, -um; gen. -īus, [unō + lus], adj., *a single* (with negatives), *any*. — As subst. (less common), *anybody*.

**ulterior**, -ōris, [comp. of ulterō-, cf. ultra], adj., *farther*: *ulteriores* (*those farther off*). — Superl., **ultimus**, -a, -um, [ul + timus], *farthest*.

**ultrā** [unc. case, perh. instr. of †ulter], adv. and prep., *beyond*.

**ultrō** [dat. of †ulter (us)], adv., *to the farther side, beyond*: *ultra citroque* (*this way and that*). — Esp. beyond what is expected or required, *voluntarily, without provocation, besides*: *bellum inferre* (*make an offensive war, make war without provocation*); *sibi parcere cogi* (*in spite of himself*); *ad se venire* (*without his asking it*).

**ultus**, -a, -um, p.p. of *ulciscor*.

**ululātus**, -tūs, [ululā + tus], M., *a yell*.

**umerus** (*humerus*), -ī, [?], M., *the shoulder*.

**umquam**, see *unquam*.

**ūnā** [instr. (or abl.?) of unus], adv., *together, along, with them, etc., also*.

**unde** [supposed to be for †eunde (eunc, cf. unquam, + de, cf. inde)], adv., *whence, from which*.

**undecim** [unus-decem], indecl. num. adj., *eleven*.

**undecimus**, -a, -um, [unus-decimus], adj., *eleventh*.

**undique** [unde-que, cf. quique], adv., *from every side, from all quarters*. — Also (cf. ab), *on every side*.

**Unellī**, see *Venellī*, the more approved spelling.

**ūniversus**, -a, -um, [unō-versus], adj., *all together, all* (in a mass), *entire*.

**unquam** (*umquam*), [supposed to be for cum-quam (cf. quisquam)], adv. (with negatives), *ever*: *neque . . . unquam* (*and never*).

**ūnus**, -a, -um; gen. -īus, [?, old oenus], adj., *one, a single, the same*: *una celeritate* (*alone*); *unum se esse* (*that he was the only one*).

**urbānus**, -a, -um, [urbi- (reduced) + anus], adj., *of a city*. — Esp., *of the city* (Rome), *in the city*.

**urbs**, urbis, [?], F., *a city*. — Esp., *the city* (Rome).

**urgēō** (*urgēō*), ursi, no p.p., urgēre, [√VARG, cf. vulgus], 2 v. a., *press, press hard, urge*.

**ūrus**, -ī, [Teutonic], M., *a wild ox*.

**Usipetes**, -um, [Teutonic], M. pl., a German tribe who migrated from eastern Germany to the lower Rhine.

**ūsītātus**, -a, -um, p.p. of *usitor*.

**ūsitor**, -ātus, -āri, [†usitō- (as if p.p. of †uso, freq. of utor, cf. dicitō)], 1. v. dep., *practise*. — **ūsītātus**, -a, -um, p.p. in passive sense, *used, practised, customary, much practised*.

**usque** [unc. case of quō (cf. ubi, and usquam) -que (cf. quisque)], adv., (*everywhere*), *all the way, even to, to that degree* (with eo ut), *all the time, till, even till*.

**ūsus**, -a, -um, p.p. of *ūtor*.

**ūsus**, -ūs, [√UT (in ntor) + tus], M., *use, experience*. Hence, *advantage, service*. — Esp.: *usus est, it is necessary, there is need, is necessary*

(with personal subject); also, *ex usu, usui, of advantage, of service, advantageous; usu venire, happen, occur, turn out* (on trial, in practice); *usum navium eripi, be deprived of all use of the ships; quae sunt usui, which are serviceable, are needed, are of use.*

**ut** (**utī**), [supposed to be for **quoti** (**quō + ti?**)], adv. and conj.: *a. Interrog., how. — b. Relat., as, so as, when, inasmuch as.* — Esp. with subj., *that, in order that, to, so that, so as to.* — Often with object-clause compressed in Eng. into some other form of speech: *poenam ut, etc., of being, etc.; id facere ut, do this (to wit, without "that").* — Esp.: *ut semel, when once, as soon as; timere ut, fear that not: ut quisque est . . . ita, in proportion as.*

**uter**, -tra, -trum; gen. **trīus** [**quō** (cf. **ubi**) + **terus** (reduced), cf. **alter**], adj.: *a. Interrog., which (of two): uter utri (which to the other). — b. Relative, whichever (of two), the one who (of two).* — Neut., **utrum**, adv., (*which of the two*), *whether.*

**uterque**, **utra-**, **utrum-**, **utrius-**, [**uter-que**, cf. **quisque**], adj., *both: medium utriusque (between the two).* — Plur., of sets: **utraque castra** (*both camps*); **utrique** (*both parties*). — Rarely of single things: **utraeque** (*both women*).

**utī**, see **ut**.

**ūtilis**, -e, [**†uti-** (stem akin to **utor**) + **lis**], adj., *useful, of use.*

**ūtilitās**, -tātis, [**utili** + **tas**], *F., advantage.*

**ūtor**, **ūsus**, **ūtī**, [**?**, old **oetor**, akin to **aveo**?], 3. v. dep., *avail one's self of, use, exercise, practise, enjoy, adopt, employ, have* (in sense of enjoy), *possess, show* (qualities

which one exercises), *occupy* (a town), *navigate* (a sea). — Esp. with two nouns, *employ as: aliquo adjutore (have one's services).*

**utrimque** [unc. case of **uter** (cf. **interim**) + **que** (cf. **quisque**)], adv., *on both sides.*

**utrum**, see **uter**.

**uxor**, -ōris, [**?**], *F., a wife.*

## V.

**V**, numeral for **quīque**, *five.*

**Vacalus**, -ī, [**?**], *M., the west branch of the Rhine, at its mouth.*

**vacātiō**, -ōnis, [**vacā** + **tiō**], *F., freedom* (from something), *exemption.*

**vacō**, -āvi, -ātūrus, -āre, [prob. †**vacō-** (cf. **vacuus** and **Vacūna**)], 1. v. n., *be vacant, be free from, be unoccupied, lie waste.*

**vacuus**, -a, -um, [prob. √**VAC** (cf. **vaco**) + **vus**], adj., *free, unoccupied, vacant, destitute of* (**ab** or **abl.**).

**vadum**, -ī, [√**VAD** (in **vado**) + **um**], *N., a ford.* — Plur., *a ford, shoals, shallows: vado (by fording).*

**vagātus**, -a, -um, p.p. of **vagor**.

**vāgīna**, -ae, [**?**], *F., a sheath.*

**vagor**, -ātus, -āri, [**vagō-**], 1. v. dep., *roam about, roam, wander.*

**Vahalis**, -is, [**?**], *M., another form for Vacalus, which see.*

**valeō**, **valui**, **valitūrus**, **valēre**, [**?**, prob. denominative, cf. **validus**], 2. v. n., *be strong, have weight, have influence, be powerful.* — Often with *N. pron. or adj. as cog. acc.: plurimum valet (be very strong, have great weight, have great influence); quicquid possunt pedestribus copiis valent (whatever strength they*

have is in infantry); **tantum valebat** (*had such weight that*, etc.); **pudor valet** (*self-respect controls*).

**Valerius**, -ī, [akin to *valeo*], M., a Roman gentile name. — Esp.: 1. *Caius Valerius Flaccus*, proprætor in Gaul, B.C. 83. — 2. *Lucius Valerius Præconinus*, a legatus under some unknown proprætor in Gaul. He was defeated and killed in Aquitania. — 3. *Caius Valerius Caburus*, a Gaul who received the Roman citizenship prob. from No. 1. — 4. *Caius Valerius Procillus*, and (5) *Caius Valerius Donnotaurus*, sons of No. 3, who fought for Cæsar in the war against Vercingetorix.

**Valetiacus**, -ī, [?], M., a noble of the Hædui.

**valētūdō**, -inis, [prob. *valent* + *tudo*], F., *health*. — Also, *ill health*.

**vallēs** (**vallis**), -is, [?], F., *a valley*.

**vallum**, -ī, [N. of *vallus*], N., *a palisade, a rampart* (the regular fortification of the Romans, made of stakes and built up with earth), *a wall*.

**vallus**, -ī, [?], M., *a stake*.

**Vangiones**, -um, [Teutonic], M. plur., a German tribe on the west bank of the Rhine, about modern Worms.

**varietās**, -tātis, [*variō* + *tas*], F., *diversity*: **pellium** (*different colors*).

**varius**, -a, -um, [prob. akin to *vārus*], adj., *various, diverse*.

**vastātus**, -a, -um, p.p. of *vasto*.

**vastō**, -āvi, -ātus, -āre, [*vastō*], I. V. A., *lay waste, devastate, ravage*.

**vastus**, -a, -um, [?], adj., *waste*. — Also, *immense*.

**vāticinātiō**, -ōnis, [*vaticinā* + *tio*], F., *divination*.

**vectigal**, -ālis, [N. of *vectigalis*], N., *an impost, tribute*. — Plur., *revenues* (of a state).

**vectigālis**, -e, [+*vectigō*-(*vectis*, akin to *veho*, + unc. term., cf. *castlgo*) + *alis*], adj., *tributary*: **vectigales habent** (*make tributary*).

**vectōrius**, -a, -um, [*vector* + *ius*], adj., *carrying*: **navigia** (*transports*).

**vehemēns**, -entis, [akin to *veho*], adj., *violent*.

**vehementer** [*vehement* + *ter*], adv., *violently, severely, strongly, hotly, exceedingly*.

**vehō**, vēxī, *vectus*, *vehere*, [*√VAGH*], 3. V. A., *carry*: **legionem equis vehere** (*bring on horseback*).

**vel** [prob. imperative of *volo*], conj., *or*: **vel . . . vel** (*either . . . or*).

**Velānius**, -ī, [?], M., a Roman gentile name. — Esp., *Quintus Velānius*, a tribune of the soldiers in Cæsar's army.

**Vellocasses** (**Velo-**, **Vello-**), -um (-ī, -ōrum), [Celtic], M. plur., a Gallic tribe of Normandy, about Rouen.

**Vellaunodūnum**, -ī, [Celtic], N., a town of the Senones.

**Vellāvi**, -ōrum, [Celtic], M. pl., a tribe in the Cevennes mountains.

**vēlōcītās**, -tātis, [*veloci* + *tas*], F., *swiftness, fleetness*.

**vēlōciter** [*veloci* + *ter*], adv., *swiftly, quickly*.

**vēlōx**, -ōcis, [stem akin to *volo* (cf. *colonus*) + *cus* (reduced?)], adj., *swift*.

**vēlum**, -ī, [?, cf. *vexillum*], N., *a curtain, a veil*. — Also, *a sail*.

**velut** [*vel-ut*], adv., (*even as*), *just as*: **velut si** (*just as if*).

**vēnātiō**, -ōnis, [*venā* + *tio*], F.,

*hunting*. — Plur., *hunting, hunting excursions*.

**vēnātor**, -tōris, [venā- + tor], M., a hunter.

**vendō**, -didi, -ditus, -dere, [venum do], 3. v. a., *put to sale, sell*.

**Venelli (Unelli)**, -ōrum, [Celtic], M. plur., a tribe of Gaul in modern Normandy.

**Veneti**, -ōrum, [Celtic], M. plur., a tribe of Gaul in modern Brittany.

**Venetia**, -ae, [venetō + ia (F. of -ius)], F., *the territory of the Veneti*.

**Veneticus**, -a, -um, [Venetō + cus], adj., *of the Veneti*.

**venia**, -ae, [?], F., *indulgence, favor, pardon*: *petentibus veniam dare* (*grant their request*).

**veniō**, venī, ventūrus, venire, [√GAM (for gvenio)], 4. v. n., *come, go*: *in spem* (*enjoy the hope*).

**ventitō**, -āvī, -ātūrus, -āre, [as if ventitō- (from vento, old freq. of venio)], 1. v. n., *come often, visit*.

**ventus**, -ī, [?], M., *the wind*: *vento se dare* (*run before the wind*).

**vēr**, vēris, [for †vasar, √VAS, cf. uro], N., *spring*.

**Veragri**, -ōrum, [Celtic], M. pl., a Gallic people of the Alps, on the upper Rhone.

**Verbigēnus**, -ī, [Celtic], M., a canton of the Helvetii.

**verbum**, -ī, [?, cf. morbus], N., a word: *pluribus verbis* (*at great length*); *animos verbis confirmavit* (*with encouraging words*); *facit verba* (*speak for, etc.*); *magna contumelia verborum* (*with most insulting words*).

**Vercassivellaunus**, -ī, [Celtic], M., one of the Arverni, the uncle of Vercingetorix.

**Vercingetorix**, -igis, [Celtic], M., a noble of the Arverni. Being chosen king, he made a stout resistance to Cæsar, but was finally overpowered by the Romans and surrendered by his followers.

**vereor**, -itus, -ēri, [prob. †verō- (akin to wary)], 2. v. dep., *fear be afraid*. — **veritus**, p.p. in presense, *fearing*.

**vergō**, -ere, [?], 3. v. n., *incline, slope, look towards* (of an exposure), *lie towards*.

**Vergobretus**, -ī, [Celtic], M., Celtic title of the chief magistrate among the Arverni.

**vērisimilis**, -e, [veri similis], adj., (*like the truth*), *probable, likely*.

**veritus**, -a, -um, p.p. of **vereor**.

**vērō** [abl. of vērus], adv., *in truth, in fact*. — With weakened force, *but, on the other hand*. — Often untranslatable, expressing an intensive (emphatic) opposition, or pointing to the main time, circumstance, fact, or agent in a narrative.

**Veromandui (Viro-)**, [Celtic], M. plur., a Gallic tribe in modern Picardy.

**versō**, -āvī, -ātus, -āre, [versō-], 1. v. a., *turn* (this way and that), *deal with* (some one or some thing). — Esp. in pass. as dep., *turn one's self, engage in, be, fight* (as indicated by the context).

**versus**, -a, -um, p.p. of **verto**.

**versus (versum)**, [orig. p.p. of **verto**], adv. and prep., *towards, in the direction of*.

**versus**, -ūs, [√VERT + tus], M., *a turning*. — Esp., *a verse* (of poetry, where the rhythm turns and begins anew), *a line*.

**Verticō**, -ōnis, [Celtic], M., one of the Nervii.

**vertō**, *vertī*, *versus*, *vertere*, [ $\sqrt{\text{VERT}}$ ], 3. v. a., *turn*: *terga* (*turn and flee*).

**Verudoetius**, -ī, [Celtic], M., a noble of the Helvetii.

**vērus**, -a, -um, [?],  $\sqrt{\text{VER}}$  (in *vereor*) + *us*, adj., (? *seen, visible*), *true*. — Neut. as subst., *the truth*: *repperit esse vera* (*found the truth to be*). — Also, *just, right*. — See also *vero*.

**verūtum**, -ī, [*veru* + *tum*], N., a *spear* (of a light kind), a *dart*.

**Vesontio**, -ōnis, [Celtic], F., the chief town of the Sequani, now *Besançon*.

**vesper**, -erī, [?], cf. Gr.  $\epsilon\sigma\pi\epsilon\rho\varsigma$ ], M., *the evening*.

**vester**, -tra, -trum, [*ves* + *ter* (us)], adj. pron., *your, yours*.

**vestigium**, -ī, [†*vestigō*- (cf. *vestigio*) + *ium*], N., *the footstep, the footprint, a track*. — Esp.: *e vestigio* (*forthwith, from one's tracks?*); *eodem vestigio* (*in the same spot*); *in illo vestigio temporis* (*at that instant of time*).

**vestiō**, -īvi(-iī), -itus, -ire, [*vesti-*], 4. v. a., *clothe, cover*. — Pass., *clothe one's self with* (with thing in abl.), *wear*.

**vestis**, -is, [ $\sqrt{\text{VES}}$  + *tis*], F., *clothing, garments*.

**vestitus**, -tūs, [*vestī* + *tus*], M., *clothing, garments*.

**veterānus**, -a, -um, [*veterā-* (as if stem of *vetero*) + *nus*], adj., *veteran* (long in service).

**vetō**, *vetuī*, *vetitus*, *vetāre*, [stem akin to *vetus*, cf. *antiquo*], 1. v. a., *forbid*.

**vetus**, -eris, [?], cf. Gr.  $\epsilon\tau\rho\varsigma$ ], adj., *old, former*: *milites* (*old soldiers, veterans*).

**vexātus**, -a, -um, p.p. of *vexo*.

**vexillum**, -ī, [?], apparently a diminutive of *velum*], N., *a flag*: *sub vexillo* (*in a detachment, without any signa, which were only carried in the regular corps*).

**vexō**, -āvī, -ātus, -āre, [†*vexō*- (as if p.p. of *veho*)], 1. v. a., (*carry this way and that*), *harass, annoy, commit depredations on, overrun* (a country), *ravage* (lands).

**via**, -ae, [for *veha?* (*veh* + *a*)], F., *a road, a way, a route*: *tridiviam* (*three days' journey*).

**viātor**, -tōris, [†*viā-* (as stem of *vio*) + *tor*], M., *a traveller*.

**vicēni**, -ae, -a, [akin to *viginti*], num. adj., *twenty* (apiece).

**vicēsimus**, -a, -um, [akin to *viginti*], num. adj., *twentieth*.

**vicēs** (-ēns), [akin to *viginti*], adv., *twenty times*: *vicies centum milia* (*two million*).

**vicinitās**, -tātis, [*vicino* + *tas*], F., *neighborhood, vicinity*. — Plur., *neighbors*.

**vicis**, gen. (nom. not found), *change, turn*: *invicem* (*in turn*).

**victima**, -ae, [akin to *vinco*, perh. going back to the sacrifice of prisoners], F., *a victim*.

**victor**, -tōris, [ $\sqrt{\text{VIC}}$  (in *vinco*) + *tor*], M., *a victor*. — Often as adj., *victorious*, cf. *victrix*.

**victōria**, -ae, [*victor* + *ia*], F., *victory, success* (in war).

**victus**, -a, -um, p.p. of *vinco*.

**victus**, -tūs, [ $\sqrt{\text{VIG}}$  (?), (cf. *vixi*) + *tus*], M., *living, life*. — Also, *means of living, food*: *domus victusque* (*intercourse, life in common*).

**vicus**, -ī, [ $\sqrt{\text{VIC}}$  + *us*, cf. Gr.  $\omicron\lambda\kappa\omicron\varsigma$ ], M., (*a dwelling*), *a village* (a collection of dwellings).

**videō**, *vidī*, *visus*, *vidēre*, [ $\sqrt{\text{VID}}$ , perh. through a noun-stem], 2. v. a.,

*see, examine* (reconnoitre), *take care* (see that). — In pass., *be seen, seem, seem best*.

**Vienna**, -ae, [Celtic], F., a town of the Allobroges, on the Rhone, now *Vienne*.

**vigilia**, -ae, [vigil + ia], F., a *watch, watchŋg*. The Romans divided the night into four watches, and reckoned the time thereby.

**viginti** [dvi- (stem of **duo**) + form akin to **centum** (perh. the same)], indecl., *twenty*.

**vimen**, -inis, [root (or stem) VI + men (cf. **vico**)], N., a *twig* (flexible, for weaving), *osier*.

**vinciō**, vinxī, vincitus, vincire, [perh. akin to **vinco**], 4. v. a., *bind, fetter*.

**vinculum**, see **vinculum**.

**vincō**, vici, victus, vincere, [ $\sqrt{\text{VIC}}$ ], 3. v. a. and n., *conquer, defeat, prevail*: *naturam* (*outdo*).

**vinctus**, -a, -um, p.p. of **vincio**.

**vinculum** (**vinculum**), -i, [†vincō- (stem akin to **vincio**, perh. primitive of it) + lum (N. of **lus**)], N., a *chain*: *ex vinculis* (*in chains*, see **ex**): *in vincula* (*into prison*).

**vindicō**, -āvī, -ātus, -āre, [**vindic-**], 1. v. a., *claim, claim one's rights against, defend*: *in aliquem* (*punish*); *Galliam in libertatem* (*establish the liberty of*, a phrase derived from the formal defence of freedom in a Roman court).

**vīnea**, -ae, [vinō- + ea (F. of -eus)], F., a *vineyard, a vine arbor*. Hence, a *shed* (*defence*, for a besieging party, made like an arbor).

**vinum**, -i, [?, cf. Gr. *oīvos*], N., *wine*.

**violō**, -āvī, -ātus, -āre, [?], 1. v. a., *abuse, violate* (a sacred object): *hospites* (*injure*, a guest being held sacred).

**vir**, viri, [?], M., a *man, a husband*.

**virēs**, see **vis**.

**virgō**, -inis, [?], F., a *maiden, a maid*.

**virgultum**, -i, [†virgula (?) + tum, cf. **tumultus**], N., only in pl., *shrubbery, a thicket, bushes* (cut for military purposes).

**Viridomarus**, -i, [Celtic], M., a noble of the Hædūi.

**Viridovix**, -icis, [Celtic], M., a prince of the Venelli.

**viritim** [vir + itim, as if acc. of verbal in -tis], adv., *man by man* (of distribution), *to each individual*.

**Viromandui**, see **Veromandui**.

**virtūs**, -tūtis, [virō- (reduced) + tus], F., *manliness, valor, prowess, courage*. — Also, *merit* (generally), *noble conduct, virtue*. — Plur., *virtues, merits, good qualities*.

**vis**, vis (?), [?], F., *force, might, violence*. — Esp.: **vi cogere** (*forcibly*); **vim facere** (*use violence*); **vim hostium prohibere** (*violent attack*); **vi fluminis oppressi** (*overcome by the violent current*). — Plur., *strength, force, powers, bodily vigor*.

**vīsus**, -a, -um, p.p. of **video**.

**vita**, -ae, [root of **vivo** + ta], F., *life, the course of life*.

**vītō**, -āvī, -ātus, -āre, [?, **vita**-?], 1. v. a., (*escape with life, live through?*), *escape, avoid, dodge*.

**vitrum**, -i, [?], N., *woad* (a plant used by the Britons for dyeing blue).

**vivō**, vixī, victus, vivere, [ $\sqrt{\text{VIG}}$  (**vigor**?), cf. **victus**], 3. v. n., *live*: *lacte* (*live on*).

**vīvas**, -a, -um, [ $\sqrt{\text{VIGOR}}$  (?) + us], adj., *alive, living*.

**vix** [poss.  $\sqrt{\text{VIC}}$  (in **vinco**)], adv., *with difficulty, hardly*. — Also, of time, *hardly* (. . . *when*).

**Vocātes**, -um, [Celtic], M. plur., a people of Aquitania, on the Garonne.

**Vocciō** (**Voctiō**), -ōnis, [Celtic], M., a king of Noricum.

**vocō**, -āvi, -ātus, -āre, [voc- (stem of vox)], 1. v. a., call by name, call, summon, invite.

**Vocantii**, -ōrum, [Celtic], M. pl., a tribe between the Isère and the Durance.

**Voctiō**, see **Voccio**.

**Volcae**, -ārum, [Celtic], M. plur., a people of Gaul in the Roman province, see **Tectosages** and **Arecomici**.

**Volcātius**, -ī, [?], M., a Roman gentile name. — Esp., *Caius Volcātius Tullus*, a young man in Cæsar's suite.

**volgō**, see **volgus**.

**volgus** (**vulgus**), -ī, [√VOLG + us], N., the crowd, the common people, the mass: in **volgus efferri** (be spread abroad); **militum** (the common soldiers, the army). — **volgō**, abl. as adv., commonly, generally, everywhere.

**volnerō** (**vul-**), -āvi, -ātus, -āre, [volner-], 1. v. a., wound.

**volnus** (**vulnus**), -eris, [prob. akin to **vello**], N., a wound.

**volō**, voluī, velle, [√VOL], irr. v. a. and n., wish, be willing, want: **velle aliquem aliquid** (want one for anything, want anything of one); **quid sibi vellent** (what they wanted, or meant, or intended to do, what business they had).

**voltus** (**vultus**), -tūs, [√VOL + tus], M., (wish, expression of countenance), look, countenance, face: **vultus fingere** (compose one's countenance), conceal one's feelings;

**alicujus voltum ferre** (bear the glance of one's eye).

**voluntārius**, -a, -um, [volent + arius], adj., voluntary. — As subst., a volunteer.

**voluntās**, -tātis, [volent + tas], F., willingness, good-will, consent, desire, will, approval, an inclination: **voluntates alienare** (good-will).

**voluptās**, -tātis, [volup- (akin to volo) + tas], F., pleasure.

**Volusēnus**, -ī, [?], M., a Roman family name. — Esp., *Caius Volusēnus Quadratus*, a military tribune in Cæsar's army.

**Vorēnus**, -ī, [?], M., a Roman family name. — Esp., *Lucius Vorēnus*, a centurion of Cæsar's army.

**Vosegus**, -ī, [Celtic], M., the Vosges Mountains, running northerly from the Jura along the Rhine.

**voveō**, vōvi, vōtus, vovēre, [?], 2. v. a., vow, make a vow.

**vōx**, vōcis, [√VOC as stem], F., a voice, a word, an expression, a shout. — Collectively, cries, words, talk. — Plur., talk, reports: **nulla vox audita** (not a word); **militum vocibus carpi** (taunts); **concurso ac vocibus cogi** (outcries).

**Vulcānus** (**Volc-**), -ī, [?], M., *Vulcan* (the god of fire and metals).

**vulnerātus**, -a, -um, see **volnero**.

**vulgus**, see **volgus**.

**vulnerō**, see **volnero**.

**vulnus**, see **volnus**.

**vultus**, see **voltus**.

## X.

**X**, numeral for decem, ten.

**XX**, numeral for viginti, twenty.







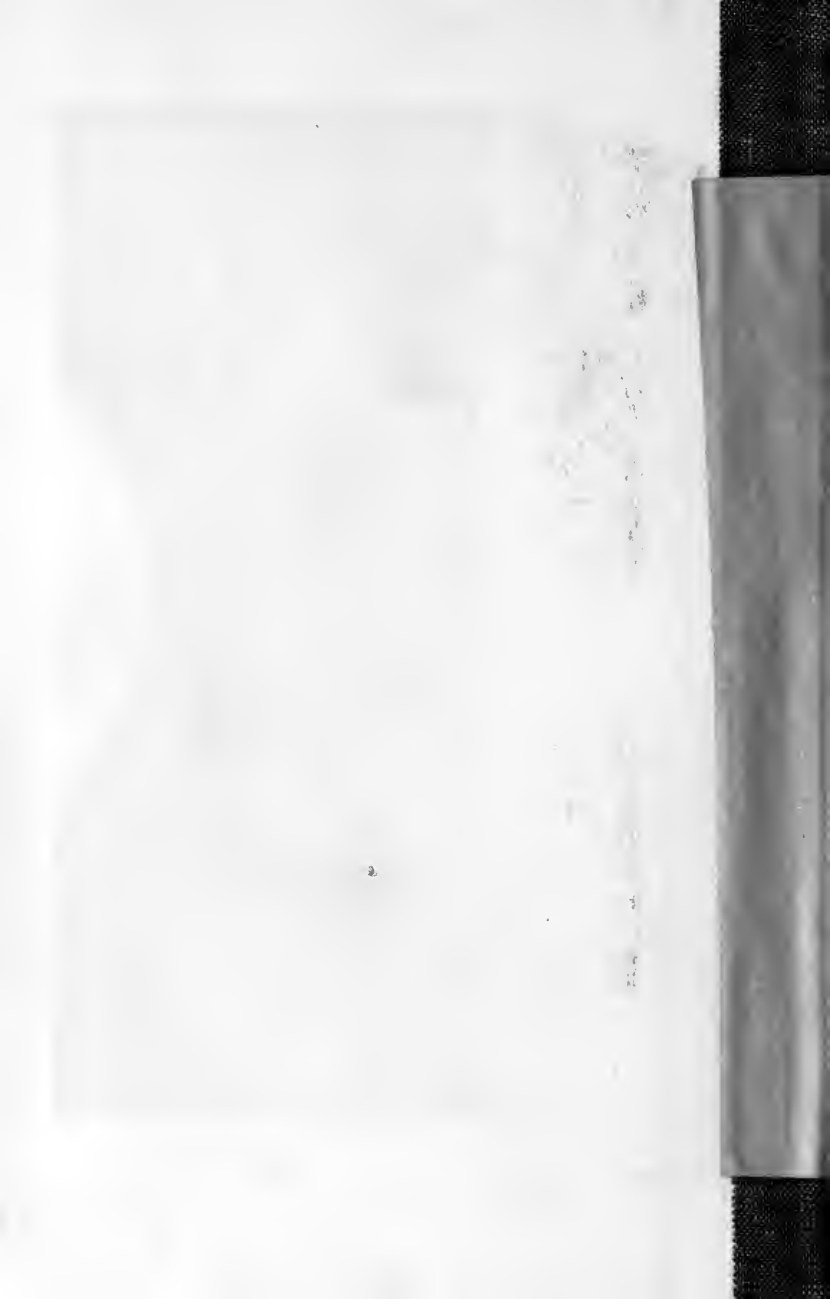

PA  
235

Caesar, C. Julius  
Gallic War

39

PLEASE DO NOT REMOVE  
CARDS OR SLIPS FROM THIS POCKET

---

UNIVERSITY OF TORONTO LIBRARY

---

