

★ UMASS/AMHERST ★

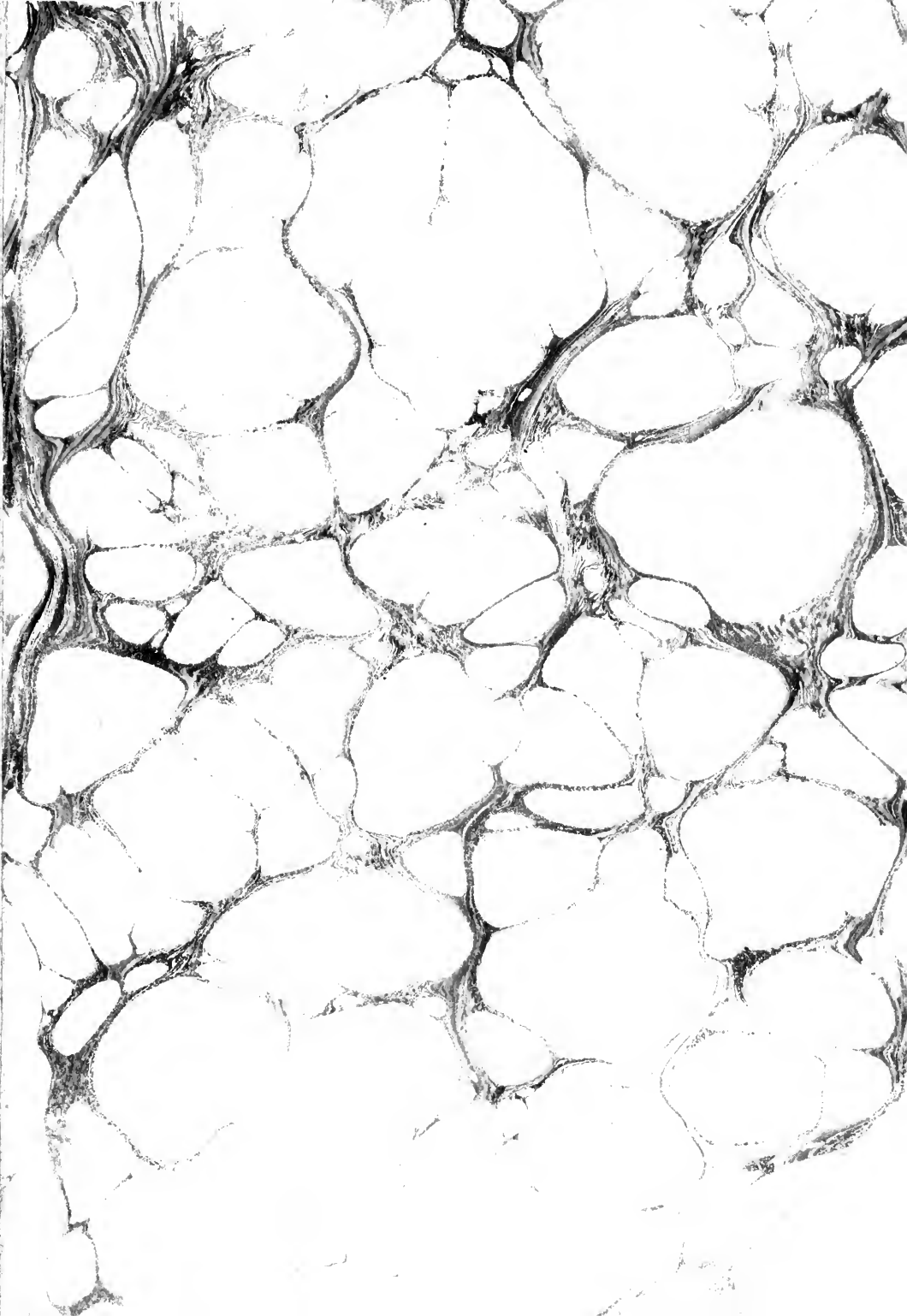

312066 0308 1382 5



MASSACHUSETTS
STATE COLLEGE



SPECIAL COLLECTIONS
& ARCHIVES
LIBRARY

C
PER
S
1
G4

1852

u13





THE
GENESSEE FARMER,

A MONTHLY JOURNAL DEVOTED TO

AGRICULTURE, HORTICULTURE,
DOMESTIC & RURAL ECONOMY.

ILLUSTRATED WITH ENGRAVINGS OF

FARM BUILDINGS, IMPLEMENTS, DOMESTIC ANIMALS,

FRUITS, FLOWERS, SHRUBS, &c.

EDITED BY

DANIEL LEE AND JAMES VICK, JR.
P. BARRY, CONDUCTOR OF THE HORTICULTURAL DEPARTMENT.

VOLUME XIII.--1852.

ROCHESTER, N. Y.
DANIEL LEE, PUBLISHER AND PROPRIETOR,
AMERICAN BLOCK, BUFFALO STREET.

1852.

30
G. 100

INDEX TO VOLUME XIII.

<p>A</p> <p>Agricultural Chemistry, No. 1,..... 9</p> <p>Agricultural Implements at Great Exhibition,..... 22</p> <p>Apples, Large,..... 29</p> <p>Agricultural Chemistry, No. 2,..... 41</p> <p>Apples, The Bailey Spice,..... 64</p> <p>Agricultural Chemistry, No. 3,..... 73</p> <p>Agricultural Progress of the U. S., Agricultural Implements at Great Exhibition,..... 84</p> <p>Agricultural Productions as shown by the Census of 1850,..... 116</p> <p>Ammonia,..... 127</p> <p>Apple Trees, Dwarf,..... 156</p> <p>Annual Flowers,..... 222</p> <p>Ashes on Potatoes,..... 227</p> <p>Acknowledgements,..... 351, 381</p> <p>Agriculture, British and American, A Fine Farm for Orcharding,..... 353</p> <p>Agricultural Papers, New,..... 352</p> <p>Agriculture in Maine,..... 353</p> <p>B</p> <p>Barns, Side-Hill,..... 20</p> <p>Bots and Colic in Horses,..... 36</p> <p>Bones for Manure, preparing,..... 37</p> <p>Butter Making,..... 51</p> <p>Barnyard Manure, the value of,..... 52</p> <p>Barley, Hess,..... 52</p> <p>Barley, Growing Flax with,..... 52</p> <p>Beet-Root Sugar,..... 107</p> <p>Bees,..... 115</p> <p>Butter and Cheese making,..... 143, 301</p> <p>Bones, to dissolve,..... 148</p> <p>Bartonia, Golden,..... 191</p> <p>Barnyard Manure, management of,..... 208</p> <p>Bee Rot,..... 213</p> <p>Budding,..... 228</p> <p>Bitter, to remove garlic taste in,..... 244</p> <p>Barley, Winter,..... 354</p> <p>Barn and Cow Stable,..... 355</p> <p>Barn-yard Manure,..... 364</p> <p>C</p> <p>Clover, Plowing in,..... 21</p> <p>Center of Gravity,..... 33</p> <p>Coal Ashes and Saw-Dust as Manure,..... 67</p> <p>Choked Cattle, to relieve,..... 84</p> <p>Carts,..... 93</p> <p>Cows and Carrots,..... 105</p> <p>Cloth for Hot-Beds,..... 127</p> <p>Coal Tar,..... 127, 160</p> <p>Corn for fodder,..... 160</p> <p>Cattle, Hungarian,..... 184</p> <p>Cheese making from a small Dairy,..... 209</p> <p>Glover Seed, a few words on growing,..... 211</p> <p>Cucumbers, how to prevent from being destroyed by the Striped Bug,..... 213</p> <p>Cow, A good,..... 213</p> <p>Corn ground with the Cobs for food,..... 226</p> <p>Calandrinia,..... 256</p> <p>Celery, Cultivation of,..... 258</p> <p>Cattle in the West, Improved breeds of,..... 274</p> <p>Congress and Agriculture,..... 296</p> <p>Cattle and Horses, wintering,..... 354</p> <p>Cherries, New French,..... 349</p> <p>Cranberries,..... 354</p> <p>Chart of Chemistry, Youman's,..... 382</p> <p>Class Book of Chemistry, do.,..... 382</p> <p>Cornstalk Cutters at the State Fair,..... 382</p>	<p>D</p> <p>Draining, Experiments on,..... 267</p> <p>Downing, A. J., Death of,..... 280</p> <p>Drouth and Deep Tillage,..... 302</p> <p>E</p> <p>Experiment, Interesting,..... 142</p> <p>F</p> <p>French Translation,..... 22</p> <p>Fruit Trees, Dwarf,..... 26, 101</p> <p>Flower Garden at Paris, Vilmorin's,..... 81</p> <p>Flax, Culture of,..... 45</p> <p>Farm House, Plan of,..... 50</p> <p>Flax Culture,..... 79</p> <p>Fuchsia, Culture of the,..... 92</p> <p>Fruit Rooms,..... 122</p> <p>Farming in Kentucky,..... 146</p> <p>Farming in Edgar Co., Illinois,..... 150</p> <p>Fruit Culture in Indiana,..... 157</p> <p>Fumigator, Brown's Patent,..... 187</p> <p>Flax Culture and Flax Cotton,..... 241</p> <p>Forest Flowers,..... 288</p> <p>Farming in Indiana,..... 309</p> <p>Forest Trees, Beauty and value of,..... 333</p> <p>Fattening Cattle and Sheep in winter,..... 336</p> <p>Farm Gates, Improvement in,..... 339</p> <p>Flowers and Flower Seeds,..... 352</p> <p>Fruits from New Hampshire,..... 351</p> <p>G</p> <p>Garget in Cows, Cure for,..... 35</p> <p>Gas Lime,..... 38, 69</p> <p>Granary, Rat-proof,..... 68</p> <p>Garget in Cows,..... 99</p> <p>Guano, Home-made,..... 113</p> <p>Guano on Corn,..... 114</p> <p>Grape, Culture of the, and Wine making,..... 117</p> <p>Guano,..... 147</p> <p>Grubs on Melon vines,..... 149</p> <p>Grape Vine Malady,..... 158</p> <p>Girdled Trees,..... 161, 195</p> <p>Growing Melons,..... 179</p> <p>Gapes in Chickens,..... 180, 244</p> <p>Grass Seed, when to sow,..... 259</p> <p>Ground Moles,..... 290</p> <p>Guano on Wheat,..... 322</p> <p>Grapes, Preserving,..... 322</p> <p>Genesee Valley Hort. Soc., Annual Fall Exhibition of,..... 351</p> <p>Guano on Potatoes,..... 373</p> <p>H</p> <p>Horse Chestnuts, The double flowering white,..... 29</p> <p>Hogs Rooting, To prevent,..... 37</p> <p>Hams, Method of curing,..... 68</p> <p>Hot-Beds,..... 70</p> <p>Hyacinths for forcing,..... 95</p> <p>Ill-corn, Soaking corn in a solution of,..... 114, 279</p> <p>Horses for the farm,..... 119</p> <p>Hints for the season,..... 125</p> <p>Hedges,..... 150</p> <p>Hogs, Chinese,..... 152</p> <p>Horse Hoe, Wright's premium,..... 153</p> <p>Homes for the poor,..... 181</p> <p>Hints for June,..... 188</p> <p>Hort. Society of the Valley of the Genesee,..... 190, 221</p> <p>Hints for July,..... 217</p> <p>Hogs, Cooking food for,..... 259</p> <p>How can he get wisdom that holdeth the Plow?..... 265</p>	<p>Horticultural Department of the N. Y. State Fair,..... 314</p> <p>Horticultural Department,..... 346</p> <p>Hogs, Middlesex,..... 375</p> <p>I</p> <p>Irrigating and Manuring land by Steam Power,..... 187</p> <p>Iron, Patent Galvanized,..... 214</p> <p>Impoverishing the Soil,..... 245</p> <p>Impersonality of the Press,..... 382</p> <p>L</p> <p>Leached Ashes and Rotation of Crops,..... 38</p> <p>Lice on Cattle,..... 147</p> <p>Letter from Crawford Co., Pa.,..... 220</p> <p>Liebig, Letter from,..... 224</p> <p>Leicester and South Down Sheep, Leached Ashes on Wheat,..... 273</p> <p>Lice on Hogs,..... 272</p> <p>Leicester Lambs, The weight of,..... 309</p> <p>M</p> <p>Manure, Application of,..... 69</p> <p>Milch Cows and Calves,..... 110</p> <p>Merino, South Down, and Leicester Sheep,..... 114</p> <p>Manure dropped in Summer,..... 147</p> <p>Mummy Wheat,..... 153</p> <p>Manure,..... 154</p> <p>Memoranda of the Season,..... 156</p> <p>Mixing Soils and Manures,..... 171</p> <p>Machine for cutting Grass plats,..... 190</p> <p>Mixing Ashes with Manure,..... 226</p> <p>Merino Lambs, Weight of,..... 244</p> <p>Manures, Artificial,..... 269</p> <p>N</p> <p>N. Y. State Ag. Society, Annual meeting of,..... 97</p> <p>N. Y. State Ag. Society,..... 193</p> <p>Nutrition, The philosophy of,..... 203</p> <p>National Ag. Convention and Society,..... 235</p> <p>N. Y. State Fair,..... 320</p> <p>Norton, J. P., Death of,..... 321</p> <p>November, Garden hints for,..... 345</p> <p>O</p> <p>Osage Orange,..... 70</p> <p>Onion,..... 127</p> <p>Osage Orange Hedges,..... 161</p> <p>Oats as a Manure for Wheat, plowing in,..... 227</p> <p>Oregon Peas,..... 340</p> <p>P</p> <p>Peas, Description of new,..... 29, 63</p> <p>Peas, The limited duration of varieties of,..... 44</p> <p>Potato Culture, Experience in,..... 46</p> <p>Plum, The Bradshaw,..... 64</p> <p>Park, A National,..... 65</p> <p>Peas, American, in England,..... 66</p> <p>Peas, Two fine Foreign,..... 93</p> <p>Poultry, Experiment with,..... 114</p> <p>Potatoes, Experiment with,..... 115</p> <p>Peas,..... 140</p> <p>Potato Culture,..... 149</p> <p>Potatoes for Seed, large and small,..... 151</p> <p>Phlox Drummondii,..... 159</p> <p>Plants, Observations on the growth and nourishment of,..... 169</p> <p>Plowing in Green crops,..... 173</p> <p>Pear, The Eastern Beurree,..... 189</p> <p>Pears on Quince Stock,..... 218</p> <p>Peach Trees,..... 221</p>
-------------------------------------------------------------------------------------------------------------------------------------------------------------------------------------------------------------------------------------------------------------------------------------------------------------------------------------------------------------------------------------------------------------------------------------------------------------------------------------------------------------------------------------------------------------------------------------------------------------------------------------------------------------------------------------------------------------------------------------------------------------------------------------------------------------------------------------------------------------------------------------------------------------------------------------------------------------------------------------------------------------------------------------------------------------------------------------------------------------------------------------------------------------------------------------------------------------------------------------------------------------------------------------------------------------------------------------------------------------------------------------------------------------------------------------------------------------------------------------------------------------------------------------------------------------------------------------------------------------------------------------------------------------------------------------------------------------------------------------------------------------------------------------------------------------------------------------------------------------------------------------------------------------------------------------------------------------------------------------------------------------------------------------------------------------------------------------------------------------------------------------------------------------------------------------------------------------------------------------------------------------------------------------------------------------------------------------------------------------------------------------------------------------------------------------------------------------------------------------------------------------------------------------------------------------------------------------------------------------------------------------------------	---------------------------------------------------------------------------------------------------------------------------------------------------------------------------------------------------------------------------------------------------------------------------------------------------------------------------------------------------------------------------------------------------------------------------------------------------------------------------------------------------------------------------------------------------------------------------------------------------------------------------------------------------------------------------------------------------------------------------------------------------------------------------------------------------------------------------------------------------------------------------------------------------------------------------------------------------------------------------------------------------------------------------------------------------------------------------------------------------------------------------------------------------------------------------------------------------------------------------------------------------------------------------------------------------------------------------------------------------------------------------------------------------------------------------------------------------------------------------------------------------------------------------------------------------------------------------------------------------------------------------------------------------------------------------------------------------------------------------------------------------------------------------------------------------------------------------------------------------------------------------------------------------------------------------------------------------------------------------------------------------------------------------------------------------------------------------------------------------------------------------------------------------------------------------------------------------------------------------------------------------------------------------------------------------------------------------------------------------------------------------------------------------------------------------------------------------------------------------------------------------------------------------------------------------------------------	---------------------------------------------------------------------------------------------------------------------------------------------------------------------------------------------------------------------------------------------------------------------------------------------------------------------------------------------------------------------------------------------------------------------------------------------------------------------------------------------------------------------------------------------------------------------------------------------------------------------------------------------------------------------------------------------------------------------------------------------------------------------------------------------------------------------------------------------------------------------------------------------------------------------------------------------------------------------------------------------------------------------------------------------------------------------------------------------------------------------------------------------------------------------------------------------------------------------------------------------------------------------------------------------------------------------------------------------------------------------------------------------------------------------------------------------------------------------------------------------------------------------------------------------------------------------------------------------------------------------------------------------------------------------------------------------------------------------------------------------------------------------------------------------------------------------------------------------------------------------------------------------------------------------------------------------------------------------------------------------------------------------------------------------------------------------------------------------------------------------------------------------------------------------------------------------------------------------------------------------------------------------------------------------------------------------------------------------------------------------------------------------------------------------------------------------------------------------------------------------------------------------------------------------------------------

Preniums.....	223	Sheep, Fattling qualities of differ- ent breeds of.....	176	The Merveille de September Cher- ry.....	319
Plowing, English and American.....	240	Salt vs. Fire.....	175	Terra Culture.....	321
Plaster on Wheat in the fall.....	244	Sheep Frauds.....	178	The Future of the Gen. Farmer.....	329
Peas, and Pork Making.....	273	Sweet Potatoes.....	179	The wants of Social and Domestic life.....	332
Pears, Early Summer.....	282	Soiling Cattle in Summer.....	183	Transactions of the Wisconsin State Ag. Society.....	353
Pears that succeed well on the Quince.....	218	Superphosphate of Lime.....	194	The Horticulturist.....	353
Poultry.—The Hen Fever.....	311	Suggestions addressed to State and County Ag. Societies.....	201	Trial of Implements at Geneva, N. Y., July, 1852.....	353
Prepare for the Storm.....	338	Salt your Hay.....	202	Trees, Our native.....	376
Potatoes, Mulching.....	340	Stock, Cutting food for.....	205	U	
Productions of Agriculture in the U. S., Seventh Census.....	343	Soot as a Fertilizer.....	206	Under Draining.....	169
Philosophy of Tillage—Horse-Hoe- ing Wheat.....	361	Spring-flowering trees and shrubs.....	216	Unleached Ashes on Potatoes.....	214
Pea Culture in Indiana.....	372	Scab and Grub in the Head of Sheep.....	225	V	
Pomological Congress, Proceed- ings of the.....	377	Sheep, Spanish Merino.....	244	Vermont and the West.....	53
Pears, New Foreign.....	880	Sheep, French Merino.....	247	Virginia Land.....	149, 214
Q		Smut in Wheat.....	259	Vegetation, Source of the nutritious property of.....	238
Quince, The different varieties of.....	252	Strawberry, Crescent Seedling.....	285	W	
R		Sheep, The Improvement of our common.....	303	Wine Making.....	17
Rural Homes.....	16, 47	Salt on Wheat.....	323	Work for the Month.....	66
Reaping Machines in England.....	96	Sheep Rack.....	323	Water, Amount of, given off by plants during their growth.....	77
Roses, Perpetual.....	94	Sheep Rack, Cotswold.....	345	Willows.....	111
Rhubarb.....	100	Stamp Muck.....	354	Winter Barley.....	149
Ruta Baga, Large crop of.....	112	Superphosphate of Lime, Improv- ed.....	366	White Beans.....	150
Recipe for curing Sores.....	149	T		Woolen Bags as a Manure.....	160
Ruta Baga and Mangel Wurzel.....	178	The Fuchsia.....	58	Wheat, The proper time to cut.....	212
Rustic Work in Gardens.....	166	Tobacco, Culture of.....	76, 115	Woodman spare that tree.....	212
Ruta Baga and common Turnep culture.....	210	The Gopher.....	99	Wines, Hand-book of.....	219
Root Grafting.....	228	The Candytuft.....	126	Wheat Culture in New England.....	233
Roses, new.....	254	Tobacco.....	193	Wheat, Soil best adapted to the culture of.....	271
Rotation of crops.....	310	The Elements of Fertility worse than wasted.....	176	Wool per Sheep in each of the States, Average production of.....	277
S		Thick and Thin Sowing.....	243	Wheat, New varieties of.....	278
Statistics, Agricultural, European.....	12	The Rose colored Weigelia.....	281	Wheat, Sowing Oats with.....	278
Stock, The wintering of.....	13	The Pomological Convention, 2d.....	306	Weevil, The Wheat.....	290
Sheep, Breeds of, and their com- parative value.....	54	Theories examined and explained.....	298, 368	Wine Making.....	365
Spring and Summer work.....	81	To reduce solid feet to bushels.....	304	Wool growing in Michigan.....	369
Strawberries.....	90	The Advantage of Cutting Corn early.....	307	Wheat Culture.....	330
Sea Kale.....	100	The Excelsior Churn.....	305	Woolen Bags as Manure.....	340
Summer Fallows.....	139	To kill Crows.....	309	Western Exhibitions.....	350
Stall feeding Sheep.....	148			Wheat, Australian.....	353
Superphosphate of Lime and Man- gel Wurzel.....	148			Watering Sheep, &c.....	383

ILLUSTRATIONS.

DOMESTIC ANIMALS, FOWLS, &c		GRAIN CRUSHERS.	87	Rustic Flower Stand.....	50
Full blood Merino Sheep.....	50	Croskill's Archimedean Root Washer.....	88	Fuchsia—Pearl of England.....	59
South Down Sheep.....	57	Steam Engine for the Farm.....	89	do Magnificent.....	60
Leicester Sheep.....	57	Wright's Premium Horse Hoe.....	153	do Serratifolia.....	61
Outline of the Wild Tartarian Horse.....	119	Brown's Patent Fumigator.....	187	do Globosa.....	62
Outline of the Modern Hunter.....	120	Patent Grass Cutter.....	190	Outlines of Pears.....	63
Outline of the Head of the Arabian Horse.....	120	The Excelsior Churn.....	308	STRAWBERRIES.—Burr's New Pine, Hovey's Seeding, British Queen, Elton.....	90,
Outline of the Head of the Hunga- rian Horse.....	120	FARM BUILDINGS.		Outline of Pears.....	93
A Suffolk Stallion.....	121	Side Hill Barn.....	20	German Ten Week Stock.....	96
Chinese Hogs.....	152	Suburban Cottages.....	47	The Candytuft.....	126
Hungarian Cattle.....	184	Plan of a Farm House.....	50	Phlox Drummondii.....	159
Group of French Merino Sheep.....	248	Rat-Proof Granary.....	68	The Easter Beurre Pear.....	189
Group of Silesian Merino Ewes.....	249	Plans of Mr. Moorman's fruit room.....	123, 134	Bartonia Aurea.....	191
Short Horn Cattle—Azalia and Lord Erholme.....	275	Plan of a Dairy or Milk House.....	196	Flowering Ash.....	217
Group of Shanghai Fowls.....	312	MISCELLANEOUS.		The Snow Drop.....	222
Group of Cochon China Fowls.....	313	Wine Making.....	19	Salpiglossis.....	222
A Cotswold Ram.....	344	Osogo Hall.....	32	Petunia Punctata.....	252
IMPLEMENTS AND MACHINES.		Center of Gravity Figures.....	33, 34	Oblong Quince.....	253
One Horse Farm Tilt Cart.....	28	Bots in Horses.....	36	Pear Quince.....	254
Liquid Manure Cart.....	24	Hess Barley.....	52	Calandrinia Speciosa.....	256
Tumbler Cart.....	25	Fibres of Wool.....	54	The Rose colored Weigelia.....	281
Garrett's Patent Horse Hoe, Side View.....	55	Mummy Wheat.....	153	Outlines of Pears.....	282, 283
Garrett's Patent Horse Hoe—End View.....	86	Stable Fittings.....	184	Malope Grandiflora.....	287
Patent Drag, Harrow, and Searifier.....	86	Farm Gate.....	339	The Merveille de Sept. Cherry.....	319
Patent Trussed Whiffle-Trees.....	87	HORTICULTURAL.		Outlines of Cherries.....	349, 350
		Double Flowering White Horse Chestnut.....	28	Dwarf Convolvulus.....	352
		Outlines of Pears.....	30	Improved Middlesex Hogs.....	374
				Baron de Mello Pear.....	380
				Bezy Goubault Pear.....	380

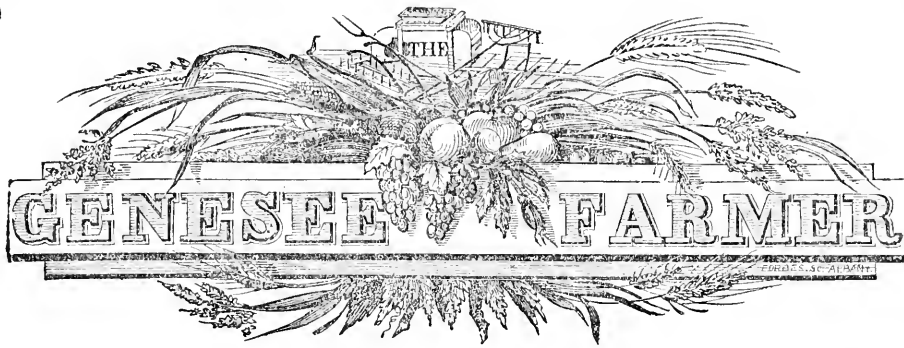

Vol. XIII.

ROCHESTER, N. Y., JANUARY, 1852.

No. I.

AGRICULTURAL CHEMISTRY.

THE winter months are particularly favorable to reading and study, and every farmer should endeavor to master some of the principles of agriculture, which the rapid progress of science renders intelligible, and the press and the public mail have dropped into his hands. Chemistry has, confessedly, done more than any other science to place the cultivation of the earth on a safe and enduring basis; and to it agriculturists in all civilized and enlightened nations are now looking for still more important discoveries, and more valuable aid in the prosecution of their noble art. The husbandman is not expected to be deeply learned in the technicalities of any natural science; and in treating of them for his perusal, one should be careful to avoid, so far as he may be able, the use of strictly professional terms. This we shall do, and when they occur, a plain definition will be given.

Chemists have found reason to believe that all matter, without exception, is endowed by its Creator with an ever-active *force* which tends to the formation of compound bodies. What are called chemical affinity, attraction of cohesion, and gravitation, are so many visible manifestations of this natural power. A knowledge of the laws regulating this force, as they affect all the elements of soils and their vegetable and animal products, may be regarded as the Science of Agricultural Chemistry.

When iron is exposed in a damp atmosphere, it *rusts*; and the observer witnesses a common but highly interesting phenomenon. There evidently exist forces in the atoms of the metal and those of oxygen, in the water or atmosphere, which cause these gaseous and solid bodies to unite and form a permanent compound of vital air and a metal called the red oxide, or per-oxide of iron. By this union of unlike atoms their respective forces are not annihilated, but are *quiescent*, and will be active and ready to act again so soon as heat or any other disturbing element shall separate the oxygen from its *base*. It is important in the study of natural laws, to keep in mind the fact that a force may be at *rest* and not lose its existence. It would be idle to speculate in what form a quiescent force exists; for we really know nothing of the ultimate atoms of matter itself, and need not attempt to fathom the mystery of gravitation, or of any inherent force displayed by the *molecules* of the material world. Suffice it to say in this connection, that matter organized in the tissues and vessels of living plants and animals, is not deprived of the natural forces which characterize it when wholly disorganized, and in the form of common air, water, and metals, or earths.

The development of latent or chemical forces in the elements of crops and soils, is a point to be well considered. Nothing that the husbandman can do to impart activity and progress in those changes which prepare food for plants, is of more importance than *the minute subdivision of all solids to be operated upon*. To illustrate the fundamental principle of all tillage, it may be stated that a mass of iron shows but a slight tendency

to oxidation (rust;) but when minutely divided, it can not possibly be brought even in contact with atmospheric air at a low temperature, without becoming *red hot*, and at the same time being converted into an oxide. Cobalt, nickel, and uranium possess the same property. (MULDER and MAGNUS.)

The condensation of atmospheric air in the minute pores of an exceedingly fine mineral is doubtless the source of this high temperature. Finely pulverized charcoal has been made to condense gases so much that the latent heat evolved in the operation has set the coal on fire. It is a law of nature that when a body passes from a rarer to a denser medium it gives out heat—*i. e.*, heat which was insensible becomes sensible by the simple compression or consolidation of any substance. Thus, when cold water is applied to cold caustic lime, the liquid becomes incorporated with the lime in a solid form and gives up a portion of its latent caloric, or heat of fluidity. In a similar manner freezing water in a cellar, which without the water would freeze potatoes and apples, warms it sufficiently to prevent their congelation. In this instance the sensible heat is given off from the water when transformed into solid ice. When vapor and water are converted into snow in winter, they warm the air sensibly, which elevation of temperature lasts a day or so after the fall of a deep snow. On the other hand, the expansion of water in the process of evaporation absorbs active or sensible heat, and generates cold as it renders heat quite insensible. This law is too familiar to need illustration. Heat and cold are among the most effective chemical and mechanical agents, and their influences on all bodies to expand or contract their dimensions, as well as the peculiar functions of solar light, deserve the closest study.

If a large crystal of salt or sugar be crushed into one impalpable powder, its solution in water is greatly promoted. This fact illustrates a general law, and one that prompts the grinding of much grain, the pulverization of the soil, and about half the labor of the agriculturist. No solid food of animals can pass through the walls of the intestines into the *lacteals* (milk-ducts) and the blood vessels, which is not substantially dissolved in the gastric juices; nor can cultivated, or other plants, subsist on insoluble earthy atoms. Hence, all the circumstances that favor or retard the solution of bodies in tilled land, or living systems, have a high practical value, and a scientific claim to attention. Bodies in solution are in a very favorable condition for the play of chemical forces, whatever they may be. The chemical phenomena witnessed in the cells of plants, in the production of wood, starch, gum, sugar, oil, albumen, casein, and gluten, appear to be governed more by physical than any known vital laws. The further the chemistry of vegetable and animal physiology is extended, the greater becomes human power over all the phenomena of life. We have long believed, and taught, the doctrine, that defective nutrition, and most diseases, from our simple liver-complaints and chills and fever, to the yellow fever, cholera, and plague, arise from the violation of laws which chemistry would yet fully elucidate and prevent. Even scrofula and consumption are now cured by phosphate of lime (bone earth) prescribed on strictly chemical principles, or pathology. The following are cases in point:

“In the first number of the New Orleans Monthly Medical Register, we find an article by Professor SROXE, on the virtues of ‘Phosphate of Lime in Scrofula and other depraved states of the System,’ which is of some moment. It was suggested by an Essay in the London Lancet, on the ‘physiology and pathology of the oxalate and phosphate of lime, and their relation to the formation of cells.’”

“The conclusions of the author,” says Professor SROXE, ‘are based upon careful chemical research and results from the use of the remedy. His researches show that in man, as well as in vegetables and inferior animals, phosphate of lime, as well as albumen and fat, is absolutely essential for the formation of cells, and he considers that many of the pathological states of the system depend upon a deficiency of this salt. The affections in which it is advised are ulcerations dependant upon a general dyscrasia, and not a mere local affection; infantile atrophy, in those suffering from rickets and consequent diarrhoea and tuberculous diseases, particularly of the lungs in the early stages.’

“Struck by this article, Prof. SROXE tested it, and he thus describes three cases in which its virtues were very obvious. The first was that of a slave who was admitted to the Professor’s Infirmary in

July, with a disease of the nose, the whole system showing great progress in serofulous decay. The usual remedies were unsuccessfully applied until August, when cod liver oil was used, but the disorganization of the stomach was increased by it. The phosphate of lime was then applied, eight grains three times a day. Its good effects were soon apparent. It and the oil were therefore administered together, and the patient soon was restored to health.

"The second case is that of a young lady aged 24. Her disease was one of 'unmixed phthisis,' which might have been expected to terminate in the course of a few months fatally. The upper part of both her lungs was filled with tubercles, and in some places were beginning to soften. The case was evidently a bad one. The treatment of cod liver oil was at first used, but without marked improvement. The phosphate of lime was then administered with the oil, and the result, as in the case of the negro, was soon apparent. The patient was rapidly getting well.

"The third case was that of a child seven years of age, in which the phosphate of lime was used with complete success.

"We can only refer briefly to these cases for the purpose of directing attention to this subject. Before the dreadful diseases which they describe, scientific men have stood abashed. That there is some remedy for them we can hardly doubt; and this may, if a new thing, be the desideratum which science is in search of."

The chemical forces in blood, and the separation of bone in one set of cells, muscle in another, nerves in a third, fat in a fourth, bile in a fifth, urine in a sixth, and all other secretions, *from the same blood*, are now being investigated with an acuteness and energy never before equalled. Powerful microscopes, delicate balances, reliable re-agents, greater experience, tact, and expertness, in all necessary manipulations, promise a more rapid advancement in pathology and organic chemistry in future. To the practical farmer, the application of chemical knowledge to the feeding of cultivated plants, will probably be most intelligible, and therefore satisfactory and useful. Among the many substances that chemists have suggested as likely to fertilize the soil, the nitrate of soda, or "cubic nitre," is not the least important. It has the merit of being much cheaper than the nitrate of potash, (saltpetre,) and is, by some wheat-growers, regarded not inferior to that valuable salt. In an agricultural point of view, ammonia, which is a powerful alkali, and nitric acid, which is an intense acid, (aquafortis,) have very similar properties. Both yield available nitrogen to growing plants. Ammonia is formed by the chemical union of 14 parts of nitrogen with 3 of hydrogen; and nitric acid is formed by the chemical union of 14 parts of nitrogen with 40 of oxygen. 17 is the equivalent number of ammonia, and 54 that of nitric acid.

In the second volume of the Journal of the Royal Agricultural Society of England, there is an account of an experiment in which 42 lbs. of nitrate of soda were drilled in with seed wheat upon a quarter of an acre. The result was a gain of 2 bu. and 2 pecks in grain, and 129 lbs. in straw. The wheat weighed 155 lbs., and the entire gain in both wheat and straw was 284 lbs. In this experiment, a pound of the salt gave over 3½ lbs. of wheat, and over 3 lbs. of straw. In another series of experiments with this salt, it gave a small addition to the yield of grain, but a large gain in straw. In another experiment, with cubic petre and common salt, 112 lbs. of each being sown broadcast on an acre of wheat early in the spring, the gain was 4½ bu. (from 21 to 25½); and in another, 8.4 bu., or from 19 to 27.4. As soda is a much cheaper alkali than potash, it is highly important that experiments be made in this country to ascertain how far soda can take the place of potash in organizing starch in potatoes and the seeds of cereals, such as wheat, maize, barley, and oats. Any County Society can make a valuable experiment with carbonate of potash, (common pearlsh.) and carbonate of soda, on the growth of potatoes, corn, or wheat, for five dollars. Let all the money be paid for equal quantities of the salts named, and let these be pulverized and mixed with four times their weight of fine dry loam. Now, get a little cup that will hold about two ounces of this compound, and apply a cup full to each hill of potatoes, or corn, spreading it over at least a square foot of surface, at the time the seed is planted. The plan should be to give one or two rows of potatoes or corn a given quantity, say 16 lbs. of soda, and a like weight of potash to other rows. Leave two rows of corn or potatoes between the

manured ones, to which nothing is to be applied. The object is simply to determine, so far as one experiment can, the relative value of potash and soda as food for the plants. Sea-water contains thirty times more soda than potash; and the first named alkali may be economically extracted from common salt, by the aid of caustic lime, in a compost heap. The chemistry of this operation, as well as that of many others, will be explained in the course of the present volume of this Journal.

EUROPEAN AGRICULTURAL STATISTICS.

The following interesting statistics are chiefly compiled from a French work on Political Economy and Statistics for 1851:

WHEAT AND RYE PRODUCED IN THE DIFFERENT COUNTRIES OF EUROPE, IN HECTOLITRES.*

States.	Wheat.	Rye.	States.	Wheat.	Rye.
France	89,143,733	51,835,466	Russia	19,000,000	149,750,000
Great Britain	35,473,000	1,500,000	Meecklenburg	622,460	1,200,000
Belgium	4,091,916	5,433,606	Hanover	1,320,000	2,000,000
Prussia	6,684,000	45,876,000	Saxony	1,100,000	2,337,500
Bavaria	2,770,607	6,418,514	Wurtemberg	6,154,821	540,558
Baden	2,570,300	510,600	Hesse	1,915,000	2,200,000
Switzerland	1,000,000	1,200,000	Other German States	1,250,000	3,500,000
Sardinian States	3,300,000	1,000,000	Austria	29,100,000	38,710,524
Spain			Tuscany	1,500,000	500,000
Netherlands	1,999,902	1,597,906	States of the Church	8,000,000	
Luxemburg	220,000	350,000	Two Sicilies	19,997,700	
Denmark	840,000	4,480,000	Other Italian States	3,500,000	
Schleswig-Holstein	856,200	1,692,600	Portugal	3,510,000	2,528,500
Sweden and Norway	342,665	5,947,820	Greece	275,000	

In some of these countries, barley, oats, maize, buckwheat, peas, and beans, are important staples.

It is a note-worthy fact that, while we obtain the official agricultural statistics of most of the nations of Europe for 1851 before the close of the year, those of the crops grown in the United States in 1849, and taken by the census of June, 1850, we shall not get till after June, 1852. The fault is in a Congress wholly devoted to party politics. Every sensible man knows that it is not necessary to wait three years after the harvest of 1849 before the public can learn the amount of said harvest.

The careful study of agricultural statistics is both instructive and interesting, after one has acquired a taste for researches of this kind. If we convert the *hectolitres* of wheat and rye grown in France and Great Britain into bushels, and consider each in reference to the agriculture of both nations, it will be seen that while England excels in *tillage*, France greatly excels in *husbandry*. France produces 224,402,453 bushels of wheat a year, and 145,139,305 bushels of rye. England produces 99,324,400 bushels of wheat, and 4,200,000 bushels of rye. To produce their comparatively small amount of grain, the poor husbandmen of Great Britain require about 230,000 tons of imported guano and an immense quantity of oil cake, used first to feed cattle and sheep, and then as manure. The good husbandmen of France require very little guano or oil cake from abroad, while they annually export to England one-fourth of the bread-stuffs imported into that country. The secret of French and Belgian success in grain-culture is this: Their cultivators make the *excreta* from millions of people worth an average of five dollars a head per annum, as manure. At this rate, allowing the fertilizers from six millions of persons to be lost in France, and those yielded by thirty millions to be saved, their commercial value to the nation is \$150,000,000 a year. The general saving of the elements of wheat, in France, is good husbandry, whatever may be their system of tillage.

On the other side of the Channel, the twenty-nine millions of people habitually throw away the fertilizing elements contained in their daily food. Hence the necessity

* One *hectolitre* is two and eight-tenths bushels.

of importing into Great Britain so much grain, flour, provisions, and guano. Some night-soil is saved, perhaps five or ten per cent. of the quantity that might be; but the loss of that from twenty millions of persons, is equal to casting \$100,000,000 into the sea. Of our population, now twenty-five millions, no class saves fertilizers equal to the consumption of one million people, or four per cent. of the whole, so that our annual loss exceeds \$100,000,000 from this source alone. But we habitually waste the droppings of our domestic animals, and, unlike England, export vast quantities of cotton, breadstuffs, and provisions, which added to the elements of crops washed out of the soil in the process of tillage, and by the action of our hot summer sun, bring up our loss, otherwise than in food consumed, to at least another \$100,000,000 a year. More than 20,000,000 acres are devoted to the production of annual harvests, in the Middle, Western, and Southern States, whose crops are sent out of the States in which they are grown. To apply a ton of guano to each ten acres thus deprived of the things that make grain, meat, cotton, and tobacco, allowing only 200 lbs. to the acre, would demand the annual importation of *two million tons*. This would cost in our seaports \$40 per ton, or \$80,000,000. But there are at least 60,000,000 acres being gradually impoverished in the United States; and a single dose of manure, equal in value to four dollars per acre, involves an outlay of \$240,000,000 a year. By carefully husbanding manure, the farmers of Belgium, after feeding the densest population in Europe, have a considerable surplus of meat and grain for export. It is only the people who speak the English language that fail to appreciate this obvious truth:—*The inhabitants of Cities are bound to feed the land which feeds them.* The citizens of London and New York do not possess common sense enough to comprehend one of the plainest laws of Providence. Our rural economy is anything but *economical*, and that of Great Britain is but a shade better.

LIVE STOCK IN SEVENTEEN OF THE LARGEST NATIONS OF EUROPE IN 1851.

	Horses.	Cattle.	Sheep.	Pigs.	Goats.	Asses & Mules.
France,	2,818,196	9,986,536	32,151,430	4,910,720	964,300	787,330
Great Britain,	1,500,000	6,865,000	32,000,000	4,000,000	210,000	—
Russia,	13,660,000	22,120,000	39,000,000	6,300,000	1,550,000	—
Austria,	2,827,130	11,471,623	33,767,000	7,000,000	448,000	92,903
Prussia,	1,570,000	5,042,000	16,260,000	2,116,000	395,000	—
Belgium,	250,000	912,740	730,649	421,208	85,000	—
Turkey,	1,950,000	8,200,000	14,300,000	300,000	1,500,000	—
Spain,	300,000	2,000,000	18,000,000	2,000,000	4,000,000	900,000
Denmark,	325,019	834,173	1,164,544	157,599	—	—
Bavaria,	349,690	2,625,294	1,899,898	842,851	107,236	—
Sweden and Norway,	501,378	2,474,615	2,854,180	892,438	177,470	—
Hanover,	257,390	794,000	1,631,000	201,000	8,000	—
Wurtemberg,	166,350	1,186,750	676,659	167,219	27,947	—
States of the Church,	64,500	171,800	1,256,000	246,200	123,300	5,500
Two Sicilies,	150,000	400,000	4,000,000	2,000,000	1,000,000	210,000
Portugal,	317,000	740,000	4,980,000	720,000	1,400,000	—
Greece,	120,000	900,000	2,500,000	40,000	300,000	—

THE WINTERING OF STOCK.

THERE are three facts connected with the wintering of stock which ought to be well considered by every one who keeps a cow, horse, pig, or sheep.

1. It is a fact that the production of animal heat in the body consumes more than half of the food taken into the stomach.

2. It is a fact that external warmth serves as an equivalent of food to an extent which is of great economical importance.

3. It is a fact that the aliment daily taken into the systems of all animals, should be precisely adapted, by its chemical composition and solubility, to the natural wants of every organ and tissue in the living being.

To the above, we might add other truisms in the keeping of domestic animals, did not long experience admonish us that a few facts, clearly stated, are more useful to a majority

of readers, than any attempt to express in one article all that ought to be said on any important topic in husbandry. It may be asked how we know that more than a moiety of food eaten by a horse, ox, or sheep, goes to create animal heat? This is our answer to that question: By the analysis of hay, oats, corn and corn-stalks, and other food of stock, we learn the amount of carbon, (coal,) oxygen, hydrogen, and nitrogen, that 100 lbs. contain. It is known that sensible heat is always generated when carbon, in vegetable substances, (of which wood and coal are familiar examples) combines chemically with oxygen, as in combustion. Now, nearly two-thirds of the carbon taken into the stomach in forage, roots, or grain, passes out of the wind-pipe, in combination with oxygen, (vital air,) as carbonic acid. It is just as impossible to burn 20 lbs. of hay in the system of a horse, or cow, and not have it evolve heat, as it would be to burn the same hay in a stove without so much as either warming the fuel or the stove. There is really no more mystery about the production of animal heat through the agency of respiration and digestion, than there is about the heat in a steam boiler; but the needless waste of animal heat, and of the fuel that generates it, in the six coldest months in the year, in this country, amounts to a loss of many millions. To prevent this loss, is the main object of our present writing. It can be done by providing warm and comfortable stables, houses, and sheds, for all kinds of stock, including poultry and honey-bees. By ceiling stables in wooden barns inside with rough boards, and filling the space between the outside boards and the ceiling with dry tanbark, or dry horse dung, we have made them sufficiently warm, so that no manure would freeze in them except in extremely cold weather. In basement stables, surrounded by thick walls laid in mortar, and covered by a floor and hay or grain, a word of caution is necessary, not to forget due ventilation. A great many horses, cows, and oxen, are injured by being kept in badly ventilated stalls and stables. Let it never be forgotten by persons sleeping in tight rooms, and by those that rear and keep domestic animals, that the air expelled from the lungs in breathing, *always contains one hundred times more carbonic acid gas* than it did when it entered them. This poisonous gas should have a reasonable outlet from all stables, especially where many animals are kept in one apartment. Nothing but knowledge will enable a farmer to combine warmth and ventilation for the health and comfort of all that breathe, whether in his own dwelling, in stables, pig-styes, bee-hives, or poultry houses. In this, as in all other matters, extremes are to be avoided.

In wisely selecting the food which is best adapted to the natural wants of neat-cattle, milch-kine, working teams, sheep, and poultry, we all have much to learn. Agriculturists in the Southern States do not appear to understand the art of preparing forage plants, such as cornstalks, straw from grain, grass, or hay, for consumption, so well as do the cultivators of the North, where long winters compel more attention, and give greater importance, to the subject. We have been particularly impressed with the neglect of corn, in Maryland and Virginia, a month after it should have been cut up at the roots with a view to make forage of the stems, leaves, and "shucks," for the stock. That is to say, we have seen corn so cut up there after several frosts, and when dead ripe, and a whole month too late, according to the maturity of the crop. All cereal plants undergo important chemical changes at the time of, and immediately after, the ripening of their seed. What these changes are will be hereafter explained, under the head of Agricultural Physiology. At present, we will assume that the farmer has feed enough for the animals he intends to winter; and if he has not, he cannot reduce his stock, by the sale of a part, a moment too soon.

The value of cutting feed, such as straw, cornstalks, and hay, is a matter on which we all need more light. It is the general belief that it pays well for the labor; but will it pay to cut good hay, even for working cattle? If one has hired help, and nothing else for them to do while cutting hay, doubtless it will aid digestion to cut up the stems and leaves of forage plants. And it may be good economy, as is often done,

to use a horse-power for cutting both dry and green feed, such as roots and straw. We have cut the feed of fifty cows in that manner, and thought we realized a profit in the operation; but we usually poured boiling hot water, drawn from a heater, over 100 bu. of cut cornstalks, hay, or straw, in a water-tight box, and let it remain till cold and eaten. This mass of hot water greatly promotes the extraction of all the nutriment there may be in stalks, leaves, and shucks or husks, by the organs of digestion. Meal, bran, or shorts, are mixed with the cut feed before the water is applied; but in feeding cut carrots, (of which we have fed a good many,) they were given raw and separate. One hundred pounds of carrots ought to yield at least fifty of milk, in good cows. The production of milk, however, is an operation of which we shall speak at another time. How to make flesh and fat to the best advantage, are points of some interest to those who keep animals and prepare them for the butcher. Our own observation leads to the conclusion that it is better economy to boil corn, peas, and barley, for fattening hogs and cattle, without grinding, if one has to pay from 8 to 16 per cent. of the grain to the miller. Cooking food, like "homony," renders all its nutriment available, and grinding can do no more, and one loses the toll, whatever that may be. Nature maintains animal heat for chemical purposes, or, to aid in transforming vegetable into animal tissues. Cooking food is a step in the same direction, for it effects important chemical changes in the substances cooked. How far hot water may be economically used in preparing forage, seeds, roots, tubers, apples, and pumpkins, for the consumption of fattening cattle, must be decided by future experiments. Whatever feed domestic animals receive, it should be given them at stated periods of the day; and all that is left, should be promptly removed, that the animal be not allowed to breathe upon it and taint it with the foul exhalations from the body. One of the most common errors in wintering stock, is the notion that they should not gain as much in weight when kept up, or fed in a yard, as when running in a good pasture in summer and autumn. Every day that a pig, heifer, steer, lamb, or colt, lives without growing, involves the owner in expense and probable loss. The art of stunting young animals is more practiced than studied; and the principles of making Shetland ponies, and such wee-bits of oxen, cows, and hogs, as one meets with in some States, ought to be known to all. Nature kindly contracts the body to meet the limited supply of food, by bringing the system prematurely to ripeness, till some of the adult horses weigh considerably less than the largest sheep. To add weight in muscle and fat, over and above the daily loss by necessary absorption, the keeper of young animals must give them more than barely enough to maintain life; and yet this is the rule of many a farmer in wintering his stock—hogs, cattle, and sheep. What an animal requires according to the weight of its body, to make good the wear and tear of ever-consuming life, in the hourly removal of the elements of bone, tendon, nerve, cellular and vascular tissue, fat, &c., is not known. When an adult animal neither gains nor loses weight, if we subtract from its food all that is voided by the bowels and kidneys, and in respiration, the excess is mostly appropriated to repair the waste in solids, which is constantly in progress. But the effete matter (dissolved solids) pass out of the system mingled with the residuum of food daily eaten, and we have no means of separating the carbon from the brain or muscles, in the carbonic acid that escapes from the lungs, from the carbon in the blood derived directly from food.

Although we cannot say that such a per cent. of aliment goes to repair the bones, such a per cent. to make muscles, or nerves, or fat; yet it is easy to determine by experiments, what kind of food, in what condition, and how much, one should feed to obtain the highest profit. As a general proposition, it may be truly said that about one-third more animals are kept than the food to keep them on will warrant. Life is supported, but *meat* is greatly decreased in quantity and value. The corn that will keep a hog six months without gaining a single pound in flesh, will make 75 lbs. of good pork or bacon if skillfully fed. The same rule applies to all domestic animals. Instead of using the

daily feed of cows to elaborate milk or flesh, the system consumes it all to make the vapor and gases that escape from the wind-pipe, and the excreta from the skin, kidneys, and intestines. In keeping dairy cows, and sheep, we have had occasion to investigate grass, hay, roots, and corn, when eaten by these and other animals.

RURAL HOMES,

OR SKETCHES OF HOUSES SUITED TO AMERICAN COUNTRY LIFE.

THE above is the title of another book on rural subjects by GERVASE WHEELER, the very name of which makes one feel comfortable and invites a hearty perusal of its pages. "RURAL HOMES"! what an association of pleasant thoughts these words call forth—how enchanting to those, who, with a heart full of the real and imaginary charms of the country are doomed to the narrow, noisy limits of a street house in the city. DOWNING'S delightful works on Country Houses and Cottage Architecture, as well as on Landscape Gardening, created a new era in the rural life of this country; perhaps no man can look abroad and witness more satisfactory evidences of the salutary influence of his labors. From one end of this great country to the other, the traveler recognizes, at least, *attempts* at the models he has given, showing conclusively that people have begun to read and think upon the subject of architecture, and whatever concerns the comfort, convenience and beauty of their homes. This is a great point gained, and we may count henceforward upon rapid and steady progress. Many errors will no doubt be committed, until more accurate knowledge is obtained, and taste more cultivated and refined. For the attainment of these ends we must depend mainly upon the circulation of sound writings. The character of Mr. DOWNING'S works is now well known, and it is unnecessary to recommend them to all who wish to read on the subject, to increase their knowledge or refine their taste. The book before us now is one we can also recommend most heartily. We have given it a pretty thorough and careful perusal, and the pleasure and instruction we have derived makes us feel grateful to the author, and bespeak for his book a place in the library of every intelligent person whoever expects to build or improve a suburban, village, or country house.

Mr. WHEELER is an experienced practical architect, and therefore not only treats of style and construction in general, but takes up all the details from the foundation stone to the chimney top, so that nothing is overlooked or forgotten. The subjects of water conveniences, warming and ventilation, so important in dwellings, and so little understood, are brought forward prominently and treated with great detail and simplicity. Excellent advice is given in regard to choosing sites for dwellings, in adapting the style to the surrounding scenery and circumstances, the exterior and interior finish, in the arrangement of fencing and grounds, disposition of outbuildings, and in fact, in whatever concerns the HOME, out-doors or in. The various branches or divisions of the subject are treated of in separate chapters, and we give a synopsis of the first, and would do so of others, did our space permit. Chapter first treats of "*The Excellencies of a House—Choice of a Site.*" Here the author points out the popular errors committed in building, and epitomises the "EXCELLENCIES" of a Home thus:

1. CONVENIENT ARRANGEMENT.
2. FACILITY OF CONSTRUCTION AND REPAIR.
3. PERFECT PROTECTION FROM HEAT AND COLD.
4. ADEQUATE MEANS OF WARMING AND VENTILATING.
5. CONGRUITY WITH THE SCENERY AROUND.

No matter what the style of a house, or what the size, these are the great points, and deserve the prominence Mr. WHEELER has given them. In speaking of the general

arrangement of the grounds, the tenor of the suggestions are unexceptionable, but to the following we must object:

"The fruit and vegetable garden, with a sheltered patch for herbs you place near the kitchen and servant's offices, and are not very anxious they should be in sight, for horticulturalise it as you will, a row of bare bean poles is not a very sightly object from a window."

We admit that fruit and kitchen gardens in general are not very *sightly*, but we believe they may, and ought to be so. Suppose, for instance, that the borders are well planted with nice pyramidal and dwarf fruit trees, the walls or fences covered with grapes or trained trees, the interior compartments well cropped with vegetables; and suppose even bean poles, not bare, but covered with beautiful running peas and beans;—such a garden would not be unsightly, but beautiful, the pride of its owner and the admiration of his neighbors. We know of a few such gardens, though but too few, in different sections of our country, and when business calls us in their neighborhood we often travel many miles to visit them. Next month we intend to present a chapter from the book, with illustrations and description of a Suburban Cottage.

WINE MAKING.

BY C. BLAKELY, OF ROXBURY, CONNECTICUT.

I SAW in the October number of your paper, a request that some one acquainted with the process of making wine, would communicate information on that subject. To the request of your correspondent, I would add my own, together with some remarks of a practical nature, such as my limited knowledge and experience may suggest, with the hope of ultimately securing the desired result. And here, as it seems to me, we should commence with the *cultivation of the grape*.

For the purpose of making wine, it is of no small importance that a kind of grape be selected that is well adapted to that particular use, otherwise the desired object will be, to say the least, but imperfectly accomplished. It is one thing to extract juice from a sour, ill-flavored grape, but quite another thing to convert such juice into good, well-flavored wine. The grape should also be adapted to the *climate*, and should ripen in season to avoid the autumnal frosts. The red, and white Scuppernon, which are a good wine grape south of 37° north, would entirely fail, for all practical purposes, in more northern latitudes. The Catawba, which has been thoroughly tried, as a wine grape, in the neighborhood of Cincinnati, particularly by Mr. LONGWORTH, and is esteemed by him one of the best wine grapes for that part of the country, besides being an excellent table grape, would probably flourish well from Washington City to Boston. I have this year raised them in great perfection, although some of them were a little injured by early frost. The Isabella, which is probably inferior to the Catawba as a wine grape, will do for still more northern latitudes.

Locality, soil, and due preparation of the ground, are other things to be considered at the commencement of grape culture. Land which has a southern inclination is preferable, and, in northern latitudes, indispensable, for those kinds which ripen late in the season. High ground, which is not too dry, is also preferable to low, marshy land, both for producing a better quality of fruit, and escaping the frosts of spring and fall.

For *propagating* the vine, I consider grafting the better mode to commence with, in case a vine with roots attached cannot be obtained. When a root is to be grafted, it is not necessary that it should be of any considerable length; neither is it necessary that the stump of the vine to which it belonged should be attached to it. Just procure a root from among the wild, native kinds, of any convenient or desirable length, then proceed to divide it into parts, say a yard in length, so that each part shall

have several lateral branches or small fibrous roots attached to it, and then insert in the butt end of each, one or two grafts, precisely in the manner of grafting fruit trees. They should then be carefully placed in the ground where they are to grow, and should receive necessary care and protection. The grafts may be cut at any time from October to March, except in warm latitudes, and may be inserted in April or May following. If they are cut in the autumn, they may be preserved by burying them in the earth, in a cool place, till May or June, but no vegetable matter should be allowed to come in contact with them, or they would be liable to mildew and rot.

When a vine with roots attached is once obtained, it is preferable to propagate by layers. To accomplish this, a vine or branch is selected in the spring, and extended on the earth near by where it is to be imbedded, so that the young shoots will start upward from the earth; and when they have acquired the height of a few inches, the vine or branch to which they belong should be carefully laid in a trench previously prepared for that purpose, and covered over with rich, mellow earth, when it will soon assume the character of a root, and will throw out small roots at short intervals along its entire length, and may, in the autumn following, be cut into almost as many portions as there are vines or branches ascending from it, each of which may be transplanted and become a separate vine.

When it is difficult or impracticable to manage in this way, as is often the case when the vines have been trained to a frame or trellis, so that there are no lateral branches near the earth, a very convenient mode of propagating is by means of boxes. Make a box, say eight inches square, and open at the top; saw out a piece from the top downward, and from two opposite sides, to the depth of a couple of inches; fill with earth, pass the vine through the opening made by the saw, confine it there and cover over with earth. It should be frequently watered through the season, or till roots are well formed, when it may be amputated and removed; thus becoming a separate vine. Several boxes may be thus attached to a single branch of sufficient length, in each of which a separate vine may be obtained. It is objected by some that this method tends rather to dwarf the plant, and to render it of comparatively slow and feeble growth. While the roots are forming and the vine is small, it may be well to prevent its bearing fruit for one or two years, as that will materially assist the growth of the plant. A few years since, Dr. G. B. SMITH, of Baltimore, practiced this method in training a single vine, till it had acquired considerable size, when he changed his treatment of it by pinching off the young and tender twigs, instead of the young fruit, as before, thereby retarding the growth of the vine, and the result was a fine crop of grapes. The vine will occasionally need pruning, and with that, as with the fruit tree, it is better to *prevent* redundant growth, by pinching off the buds or young twigs soon after they make their appearance, thus securing the more rapid growth of those parts which are designed for bearing fruit.

The grape vine, unless planted in a rich, deep, calcareous earth, will also repay well the occasional bestowment of a little manure, particularly that possessing alkaline properties. In conclusion, I would say, that with your permission, Messrs. Editors, I propose in a future number of your paper, unless superceded by some other pen, to resume the subject with which this article is headed—that of *making wine*.

We hope our correspondent will give us his system of making wine from the grape. We give the process as pursued by CORNEAU & SOX, near Cincinnati, from the gathering of the grape to the bottling of the wine, for which we are indebted to the Western Horticultural Review:

“1. *Gathering*.—The grapes when fully ripe are gathered in baskets containing about a bushel, as well as in a sort of ‘pannier’ of wood, made very light and strong, and which is supported by straps, or thongs of willow, on the back of the picker; they are brought from the vinyard in this manner and thrown upon the picking tables, where they are carefully assorted.

“2. *Picking*.—This consists in removing by hand, all green, shriveled, or decayed

grapes, which are thrown into tubs or barrels and pressed separately, to make a common wine or vinegar. The finest grapes are carried thence to the stemming apparatus, where they undergo another operation.

"3. *Stemming*.—Besides the improvement in the quality of the wine which this process imparts, there is another material advantage derived from it, which consists in the diminution of the bulk or volume of any given quantity of grapes in bunches. The large press of the Messrs. CORNEAU being capable of containing upward of a hundred bushels after the stems are removed; from which about four hundred gallons of wine may be obtained.

"Stemming" consists in separating the berries from the stem by means of the apparatus of which a wood cut is appended. The grapes are thrown on the wire sieve M,

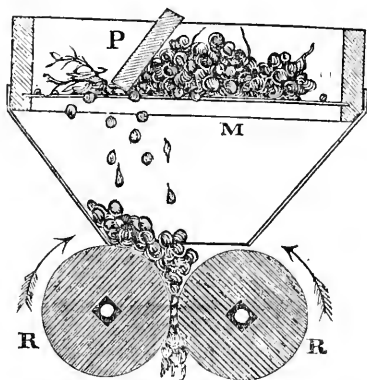

which is open enough to allow the berries to pass, but retains the stems; a little plank, P., is held in an inclined position, to which a backward and forward movement is given, so as to force the berries through the sieve, and to remove out of the way all the stems as they are stript; with the aid of this apparatus, two men can, in the course of three hours, if regularly supplied with grapes, stem from seventy to eighty bushels. Improvements might be made, by which the manual labor would be diminished; but this simple and cheap apparatus which Mr. CORNEAU has introduced, is generally used by the wine manufacturers of France.

"4. *Mashing*.—After passing through the stemming process the grapes fall into a wooden mill, consisting of two rollers ridged obliquely, to one of which is attached a set of screws by which their distance from each other may be graduated to the proper degree; it being desirable that *every grape* should be crushed but that the seed should not be broken.

"The rollers are turned by hand. The above wood cut exhibits in R, R, a section of these rollers, and that which follows shows two men, one stemming, the other mashing the grapes. From the rollers, the grape (being entirely separated from the stem and



thoroughly mashed) passes into the press, where the final operation of separating the juice is performed. The wine passes from the bed of the press, by means of a conductor, into the basement, from whence it is conveyed into casks containing 260 gallons each; these, though by no means of so large a size as those used by some of our wine manufacturers, are of a very convenient capacity for ordinary crops. The first fermentation takes place immediately, and at the end of six or eight weeks the wine becomes perfectly clear—or what is technically termed "*fine*." A second fermentation takes place in the spring, about the period of the blooming of the grape. The wine should not

be bottled until it is *at least* one year old, though it is frequently bottled for immediate use just previous to the second fermentation; this may be done with safety if the bottles can be kept in a very cool place. There are many who think the Catawba wine is better at this period than ever afterward."

SIDE-HILL BARN.

MESSRS. EDITORS:—I send you a design for a side-hill barn, with an elevation, which, if you think of sufficient merit, you can give to your readers.

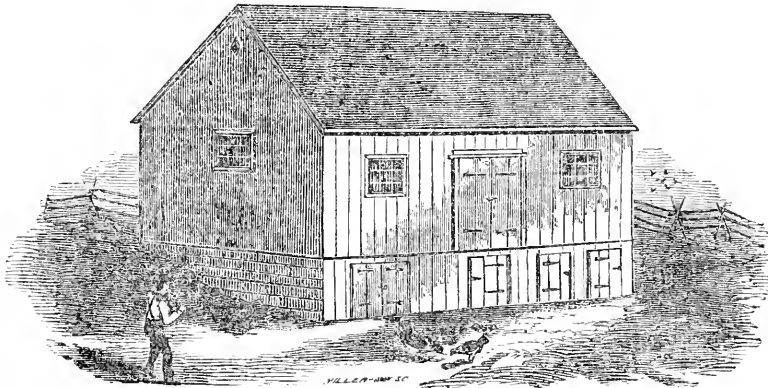

ELEVATION.—SIDE-HILL BARN.

The barn is designed to be built on the side of a hill which will allow of excavation sufficient to form the basement floor, which contains five stalls for horses and six for cattle, with a feeding passage between, into which is thrown the hay and oats through a trap door in the floor above. From this passage the mangers on either side may be filled very handily and with much less trouble and less risk of being kicked, than when a person has to come up behind the animals to get at their heads. A may be used as a carriage or waggon shed, or to store away straw for the use of the cattle or bedding for horses. R is a cellar for roots, &c.

On the main floor, H is a place for hay and oats. T, trap-door communicating with the feeding passage below. D, threshing floor, 17 by 25. C and B, cribs for corn and other grain. P, passage. S, steps leading into the basement.

The cost of this barn would probably be between three and four hundred dollars, and perhaps is as good and convenient as can be built for that sum. At least the plan is worthy of consideration. J. W. G.—Hillsboro, Ohio.

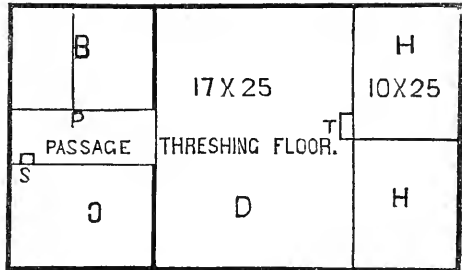

MAIN FLOOR.

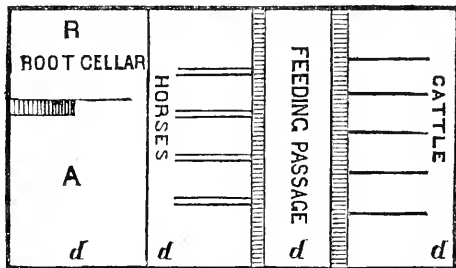

BASEMENT FLOOR.

PLOWING IN CLOVER.

BY JOSEPH HARRIS, OF ROCHESTER.

In the Patent Office Report for 1850-51 we find the following interesting remarks on the cultivation of wheat :

"Mr. F. D. KINGMAN, of Bergen, Genesee county, N. Y., says that his 'crops of wheat for the last five years have averaged thirty-two and a third bushels per acre.' We commend this fact to the notice of those who have been led to believe that the 'Genesee country' was failing to produce the great staple for which it has long been celebrated. Mr. K. has the following remarks on wheat culture :

"Time of seeding, from 1st to 16th September; of harvesting, from 20th to the last of July. Brine and lime seed, and sow one bushel and three-fourths per acre; sometimes I sow two bushels, but find it too thick. Plow three times: have this year procured one of Nourse & Mason's subsoil plows, and subsoiled a part of each wheat field. It takes three heavy horses to haul the surface plow seven inches deep, which is my gauge. Subsoil with a yoke of oxen and a pair of horses, driving the plow six inches below the cut of the surface plow. The increase is from eight to ten bushels per acre. Within the last ten years, I have not been troubled with the Hessian fly but once. Price of wheat, from \$1 to \$1.12. At least one-third of my wheat is sown after spring crops, and clover always follows, being sown in April, at the rate of ten pounds of seed per acre with one hundred of plaster. I turn nothing into clover fields in the spring; and when it is half in blossom, turn under with the plow. I now raise too much straw, and feel the need of understanding chemistry to learn what to apply to increase the berry. We once had a chemist at Rochester (Dr. LEE) who would give the desired information, but I did not then know that it was needed by me."

It would appear folly to condemn any system of culture or rotation that yields on an average of five years thirty-two or thirty-three bushels of wheat per acre, and we have no desire to do so; yet the fact that too much straw is produced from plowing in clover is a significant and interesting corroboration of scientific experiment, and deserves some notice.

It has been shown by Mr. LAWES' experiments, that when wheat is supplied with ammonia, (nitrogen and hydrogen,) it obtains sufficient carbon from the carbonic acid of the atmosphere; and that when carbon was supplied, either as farm-yard dung, rape cake, or ground rice, the crop was increased only to that extent which the ammonia they contained would alone have benefited it. Thus: two hundred pounds of sulphate of ammonia, containing forty pounds of nitrogen *and no carbon*, had as great a beneficial effect as eight hundred pounds of rape cake, containing the same amount of nitrogen and some *six hundred pounds of carbon besides*. The same effect was produced with the ground rice and farn manure—no benefit being derived from the carbon. It was also found that as large a crop could not be raised with rape cake as with ammoniacal salts; for when rape cake was supplied in sufficient quantity for its nitrogen to be equal to that supplied in the ammoniacal salt, the straw was so unnaturally developed that the crop was laid and an inferior quality and less quantity of grain produced. That this effect was caused by the superabundance of carbon in the soil, few, we think, will question. The uniformity of the results through a series of experiments for several years leaves no doubt on our own mind, and had we space the point might be illustrated from numerous facts of which every farmer is cognizant.

A ton of dry clover hay would contain about 40 lbs. nitrogen, 960 oxygen, 740 carbon, and 80 hydrogen. It will be seen that when this is plowed in for a few years, that oxygen and carbon would accumulate in the soil to an injurious amount, and "too much straw" would be raised, especially on soils in which there was not an abundance of lime and saline substances. Now, nitrogen being the only element of value that is gained by the growth and plowing in of clover, and carbon and oxygen being injurious, it is an interesting inquiry—How can we get rid of these substances and retain the nitrogen? Nature has furnished the means, and fortunately science has discovered them. When food is consumed by animals, the carbon and hydrogen it contains is burnt in the lungs to supply animal heat, while the nitrogen and greater part of the earthy matter is

voided in the liquid and solid excrements, which may be returned to the soil, where, providing there has been no loss, they will be more beneficial than had the food itself been plowed in. This method also affords an opportunity of enriching the nutritive qualities of the food and greatly increasing the value of the manure by giving to the animals, with the clover, rich nitrogenous foods, such as oil-cake, peas, beans, &c. But this is "high farming," and requires more capital than most farmers are willing to invest on their farms. To these generally, any caution about growing "too much straw" is unnecessary: plowing in clover is the best thing they can afford to do; and in a few years, when by this means their straw grows too rank, they will have spare capital to invest in more stock and artificial foods.

WM. B. LE COUTEULX, of Black Rock, has furnished us with the following translation from the French, which we publish with pleasure, and has kindly promised us further favors:

REPORT MADE TO THE CENTRAL AGRICULTURAL SOCIETY OF PARIS, UPON THE DIFFERENT MALADIES EXISTING IN WHEAT IN FRANCE, particularly a new Malady which appeared for the first time in 1851.

BESIDES the accidents from vegetation, to which the wheat is subject, and which in the markets according to these different accidents, causes it to be called, *scalded, shrunk, melted or laid down wheat* &c., there are three maladies which are peculiar to it.

Reached by the first, the wheat is deformed and of bad aspect; it is almost always deprived of the re-productive germ, and very often of that substance necessary to make bread. It is called Rickety—in French *Rachitique*.

In the second, the grain, its envelope, and the ear, altogether, transform themselves into a black and dry dust, which the winds or rains carry away. It is called Coal—in French, *Charbon*.

In the third, the appearance of the wheat is altogether different, the ear keeping its exterior shape until harvest; but the least pressure with the fingers will be sufficient to crush it, and a fat, black, dusty substance, of an infectious smell, will come out of it. It is called Rot—in French, *Carie*.

The new malady which has appeared this year, (1851,) has no analogy with those above enumerated. Instead of being in the head of the plant, otherwise the ear, it is in the low part of it. This is what caused it, from its first appearance, to be called the Malady of the foot—in French, *Maladie du Pied*.

That malady has its seat close to the ground, or between the roots and the first joint of the stalk. It consists of a mouldiness which, at first sight, one would think came from being burnt. In some cases, the mouldiness covers the whole stalk, when in some others only a part of it. The part so affected dries up, dissolution commences, and it soon loses that necessary strength to bear the weight of the plant, which bends and then drops on the ground as if beaten by storm, where it would rot, was not the hand of the farmer ready to gather it.

In some parts, said malady showed itself just as the wheat was beginning to bloom; in some others before, and in many others, after. In the first instance, the harvest is entirely lost; in the second, the ear already formed still progresses, but not without some difficulty, remaining short and the grain small, giving only half a crop. If an incision be made in the mouldy place with a pen-knife, it will be seen in the interior that the cellular tissue has lost all its elasticity,—that it is no more impregnated with sap, as when in a healthy state, the fibres being stiff, dried up, breaking, and offering all the symptoms of a dead plant. If examined with the magnifying glass, it will be seen that all those white and porous filaments are nothing else than mushrooms, which, although but just rising, have had sufficient strength to stop the ascendant march of the sap and bring death to the plant.

This malady appeared most particularly in the country around Paris—in La Brie and La Beauce, in the valley of Isere, in the departments of the Rhone, Aisne, Somme, Oise, Meuse, Ardennes, and many other parts of France, from which authentic reports are not yet received.

AGRICULTURAL IMPLEMENTS AT THE GREAT EXHIBITION.

BY P. BARRY, FROM NOTES TAKEN AT THE WORLD'S FAIR.

I HAVE never seen a cart at any of our American Agricultural Fairs. There is no lack of plows, harrows, wagons, cultivators, straw cutters, &c., but no implement-maker in America, that I am aware of, has taken it into his head to make and exhibit a nice farm cart. May I take this occasion to call upon them to do so. Will not our implement dealers in Rochester suggest to their ingenious manufacturers to try their hand on carts. They will "take,"—there is no question about this. We use three in our

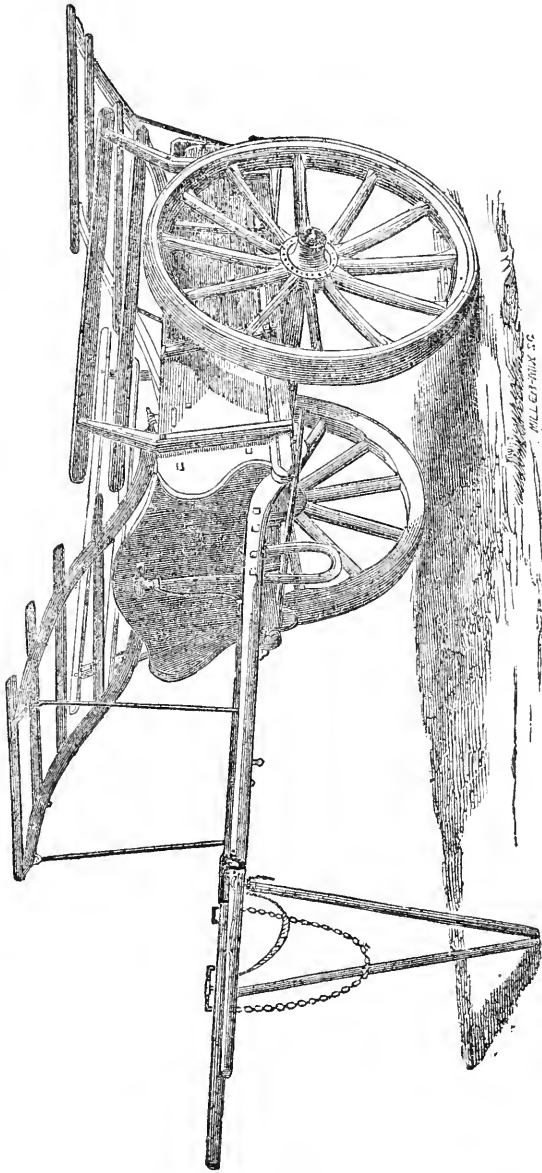

ONE HORSE FARM TILT CART. Fig. 1.

nurseries now, but they are very indifferent articles. It is hard to find a man who can make a cart "that is a cart" for the farm. I do not mean an *ox cart*—one of the most hideous pieces of mechanism that ever rolled on wheels. The moment one enters the English department of implements, he may jump at the conclusion that the cart is an implement of first importance in British husbandry. Not an exhibitor of implements but has brought along his cart as certainly as his plow. And what a variety!—the *Farm Tilt Cart*, the *Harvest Cart skeleton*, the *Liquid Manure cart*, the *Spring Cart* for fat stock, and many others. Two of these at least seem to be well worthy the attention of agriculturists in every country, and I have not the least doubt will soon be generally in use,—I mean the *One Horse Farm Tilt Cart* and the *Liquid Manure Cart*.

The annexed drawing, fig. 1, is a good model, construction simple and convenient. The body sits flat on the axle, and the shafts are attached to the bottom of the body by bent iron plates; this brings the cart level when

at work and obviates the necessity of bent shafts. The tipping apparatus is also novel: an iron bar eighteen inches to two feet long, attached to the front of the body, pierced with holes two or three inches apart, through which an iron rod goes, connecting the body and shafts. By this arrangement the body can be kept at any desired angle in unloading—very convenient in distributing manure or compost in small heaps. The shelving or ladders shown in the cut are only intended for carrying loads of grain, hay, &c. The cost of this cart in England is about \$50.

"*Busby's Prize*" Cart, which is one of the best I have seen, has a body five feet six inches long and four feet wide. Wheels four feet six inches high and four inches wide. The felloes two inches thick inside and one and a quarter inches outside. The body sits close to the axle, and is just as low as it can be to tilt. The shafts are attached to the body by the bar pivot on which the body turns. It has a shelving, or rack, composed of light boards on spreading knees or brackets; two on each side and end. On these brackets there are iron hooks that catch on the box inside and hold it firm. The price of these carts in England is \$50 for two and a half inch wheels, and \$55 for four inch wheels. All wheels for the land ought to be four inches wide, as they do not sink like narrow ones. *Wide* tires and felloes need not be so thick as narrow ones.

A Mr. ROBERTSON, from Scotland, exhibits a very neat one-horse cart with a *sliding axle*, by which the weight on the horse's back is regulated in going up or down hill.

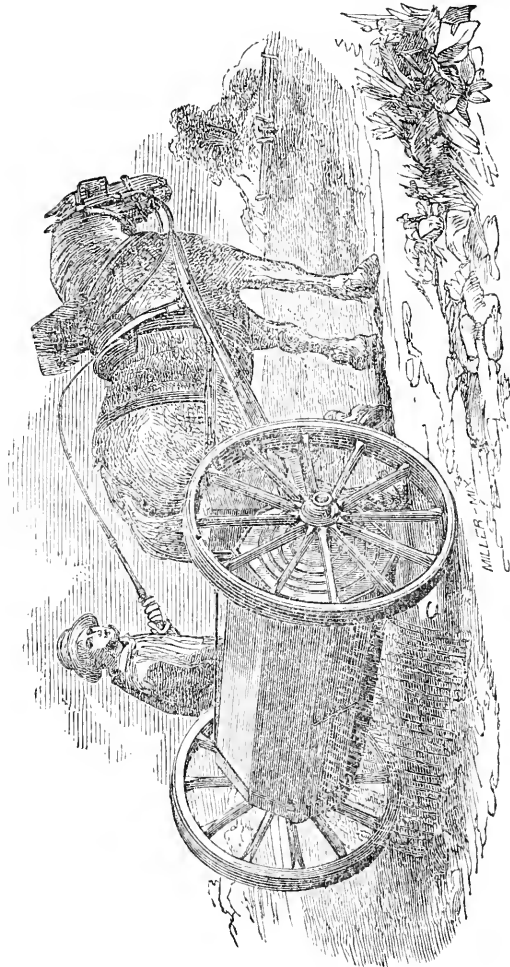

LIQUID MANURE CART. Fig. 2.

The axle is moved back or forward by the screw behind.— Several carts are exhibited so low that the shafts require to be bent to bring the body level; in other cases the shafts are straight, but attached, as in the foregoing cut, by bent iron stays that effect the same object as the bent shafts. We find by experience that *lightness* in the cart, as in all other implements, is a valuable property, and therefore the best quality of timber should be used in their construction.— Broad wheels, low bodies, simple and convenient tilting apparatus, and a nice adjustment of the *center of gravity*, are the points of importance.

The application of manures in a liquid state is now practised by the best English and Scotch agriculturists, and carts for the purpose attract considerable attention. Fig. 2 represents one called the *Cylinder Cart*, which appears to be an excellent contrivance. It consists of a wooden or iron barrel revolving upon its axle. One side of the barrel consists of a perforated board, which is kept uppermost when not at work, and to set it to work it is only necessary to turn the

barrel round. Thus valves and delivery pipes are altogether unnecessary; and however hilly the land, or however empty the barrel may be, it will always adjust itself by its own weight, and deliver its contents at a uniform rate. As a natural consequence of

this greater simplicity of construction, the price is considerably lower than that of any liquid manure cart hitherto exhibited. The cart shown in the sketch, (fig. 2,) containing 100 gallons, weighs only $5\frac{1}{2}$ cwt. It may be made of any required width, and the delivery apparatus, which is simply a perforated board, can be varied at little cost to suit every description of drilled crop, and also to manure grass lands, &c., broad-cast. It has also been advantageously used in gardens and pleasure grounds, for watering lawns and flower beds. There is a cock from which water or liquid manure may be drawn off into watering pots, or a flexible pipe or hose may be screwed into this cock, or by fixing a small force pump into the air hole of the cart, the water can be forced to any desired height.

The *Tumbler Cart* is another useful article. It is chiefly intended to carry off the sweepings of streets, nightsoil, &c. The design represented in the cut is highly approved and in very general use already in English towns. The body of the cart consists of a wrought iron tank, which is fitted with a delivery pipe and valve that can be affixed or removed in a very few minutes; so that in towns it answers the purpose of a watering cart for the streets, while for agricultural purposes the cart can at any time be adapted to the delivery of liquid manure, either from a pipe, or in the form of a sheet over the back edge of the cart.

The chief peculiarity of this cart consists in its extreme lowness, obtained by passing the axle through the body of the tank, while at the same time the convenience of completely tipping the cart is attained in the larger sizes by the introduction of an eccentric which allows the body to tip, and in fact entirely to revolve on the axle without touching the ground.

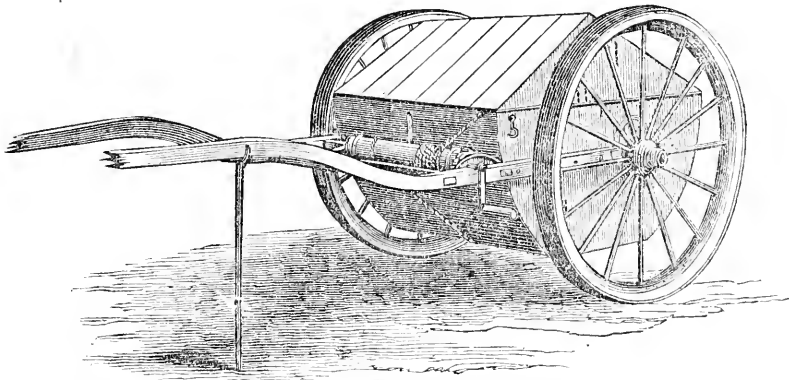

TUMBLER CART IN A POSITION FOR TRAVELING.

The great advantage of the low body for filling, not only with fluid or semi-fluid substances, but with earth, gravel, lime, or any other material, for the hauling of all which it is exceedingly well adapted, must be too obvious to require comment. For the purpose of filling, the body can be canted to any required inclination, so that the labor becomes less than that of filling a wheelbarrow, thus effecting an immense saving in the cost of carting every description of earth and minerals. The complete method of discharging the load by entirely tipping the cart, also gives it an advantage for many purposes over every other kind of cart.

I would recommend this cart to all who collect street sweepings, nightsoil, &c. To the scavengers of large cities it would be particularly valuable. In Rochester they use boxes placed on carts, from which the filth is not unfrequently sprinkled over the streets, and I have seen contrivances quite as bad in the city of New York.

Horticultural Department.

CONDUCTED BY P. BARRY.

DWARF FRUIT TREES.

A FEW years ago there was scarcely anything known about dwarf fruit trees in this country, but of late they have attracted considerable attention and their character has become somewhat understood; but there are a multitude of persons who have very faint and incorrect ideas on the subject, and therefore, although it may appear to the better informed class of cultivators a very superfluous undertaking at this time of the day, we are compelled to offer a somewhat minute explanation in justice to many whose claims we are bound to regard.

A Dwarf Tree, then, is a tree which by a certain mode of propagation and culture is reduced far below the natural dimensions; for instance, an apple, which if budded or grafted on a common apple stock will make a tree twenty, thirty, or forty feet high, and as much in diameter, covering perhaps two or three hundred square feet of ground, will, if budded or grafted on a *Paradisæ* stock, (which is a dwarf *species* of the apple, attaining only three or four feet in height,) never exceed four or five feet in height and as much in diameter, occupying little more ground than a gooseberry bush. A Dwarf Pear, is a pear tree formed by budding on a quince, or some other small species of the pear family. Thus, a pear which if budded or grafted on a common pear seedling, will attain thirty or forty feet in height with a corresponding diameter, when budded or grafted on a quince or a thorn will not exceed twelve or fifteen feet, and may even be reduced to three or four feet by working on a *mesphilus*, a *cotoneaster*, or some very small growing species of the pear family, or "alliance." So it is with other fruits, and the grand objects of dwarfing are—

First—To obtain SMALL TREES, adapted to small gardens, enabling the proprietors to enjoy a greater VARIETY than they could otherwise.

Second—To obtain trees that will correspond in APPEARANCE with the enclosure in which they are planted.

Third—To obtain trees that will BEAR EARLY, for dwarfing begets precociousness; and,

Fourth—To obtain trees that are LOW, EASY OF ACCESS in all parts, easily PROTECTED where protection is necessary, and not exposed to winds that would be likely to blow off the fruit or otherwise injure them.

These are the ordinary objects in view in dwarfing trees. But many suppose that a dwarf tree must, as a matter of course, produce dwarf, or proportionably small fruit. This is a great error, but one which the inexperienced very naturally fall into. Dwarf trees, instead of producing small fruits, or those below the natural size of the variety, very often produce them larger. In another place we have given an account of a wondrous large apple grown upon a dwarf tree. This specimen was at least one-third larger than the average product of standard trees. We have had the past season *Red Astracans* on a three year old dwarf tree about two feet high, nearly twice the usual size on standard trees, and a little standard four year old tree of *Canada Reinette* that produced four extraordinary specimens, the largest one measuring over fourteen inches in circumference. Nothing in all our grounds in the way of fruits, excited so much wonder as this, from the last of August until the 1st of November. The small size of the tree and the prodigious size of the fruit induced many to doubt the reality, supposing that some trick had been played, similar to the fastening of a gourd on an apple tree. As a general thing where a variety does succeed on the *Paradisæ*, the fruit will be larger than

on the free or common stock. So it is with pears—the largest specimens of *Bartlett*, *Louise Bonne de Jersey*, *Duchesse d'Angouleme*, or *White Doyenne*, we have ever seen, were grown upon dwarf trees. The idea, therefore, that a dwarf tree must produce small fruit is just the reverse of the fact. At another time we may offer some remarks on the cause of this.

Some imagine that to propagate Dwarf Trees it is necessary to take the scions from dwarfs. We have heard this notion advanced often, and in one case by a young nurseryman. There is not, perhaps one person in ten thousand, however, but knows better than this. Dwarfing is the result of budding or grafting on a particular stock, as we have already said, and it matters not whether we take our buds or scions from a dwarf or a standard tree, from one three feet or thirty feet high, the result will be the same, if the scions are in both cases equally healthy. We can also take buds or scions from dwarf trees and work them on common or free stocks, to produce standards.

In regard to stocks there is one point on which even many intelligent cultivators are not well informed, and that is the necessity of the stock and scion being of the same natural genera, or alliance at least. Thus, the botanical order *Pomaceæ*, or *Appleworts*, as LINDLEY renders it, in the Vegetable Kingdom, embraces the apple, (*pyrus malus*;) the Pear, (*pyrus communis*;) the Siberian Crab, (*pyrus baccata*;) the Quince, (*Cydonia*;) the Medlar, (*Mespilus*;) the Mountain Ash, (*pyrus aucuparia*;) the Thorns, (*cratægus*;) the *Amelanchiers*, of which our native Shadblow is one; the *Photinia*, the *Cotoneaster*, &c. These have all strongly marked natural affinities, and may with more or less success be budded or grafted upon each other. But the more nearly they are related—that is, the greater the congeniality in their natures, the more successful will be the union: thus, the pear will grow upon the apple, but much better upon either the quince, thorn, or mountain ash. But, if we should attempt to graft one of the species belonging to this order of appleworts, (*pomaceæ*;) upon another belonging to the order *drupacæ* or “almondworts,” [*Veg. King.*] we would be utterly unsuccessful, for these two have strongly marked botanical differences, and little or no congeniality of nature. We can never, therefore, graft apples, pears, or quinces, upon cherries, plums, or peaches.

The order *Drupacæ* or Almondwort, alluded to, embraces all the species of plum, cherry, peach, apricot and almond. These have all certain prominent botanical similarities and affinities, and may all be worked upon each other with success proportionate to the strength of the affinity: hence, the peach, apricot, almond, and plum, in general grow upon one another perfectly well, but none of them can be worked to any practical advantage upon the cherry. The genus *cerasus*, (the cherry,) contains many species, differing greatly in appearance; for instance, the *Mahaleb* and *Mazzard* are as distinct in general appearance of foliage and habit as an oak and a willow, yet they grow well one upon the other, because of a congenial nature.

We cannot at this time follow up these points further, but we have drawn attention to them, and will add that every one who aims at being an intelligent cultivator should not fail to give it attentive consideration.

Many people who have never seen dwarf trees, but order them from nurseries are quite disappointed when they see them. A tree two, three, or four feet high seems *small* to those who have all their lives been accustomed to large trees. They fear “they will never come to anything.” We have seen people in search of dwarf trees, and yet ask the *tallest* tree in a row. Dwarf apples are of course very small when transplanted. A yearling will be from one to two feet, and at two years very little taller, but branched. Such diminutive things to the inexperienced are *too small*. One man says “the dwarf apples are sprouts—not what I imagined them at all.” There is a much greater lack of knowledge on this subject than there ought to be, when books and papers that contain the remedy are so abundant and cheap. Young cultivators, think of these things during the approaching stormy weather and long evenings of winter.

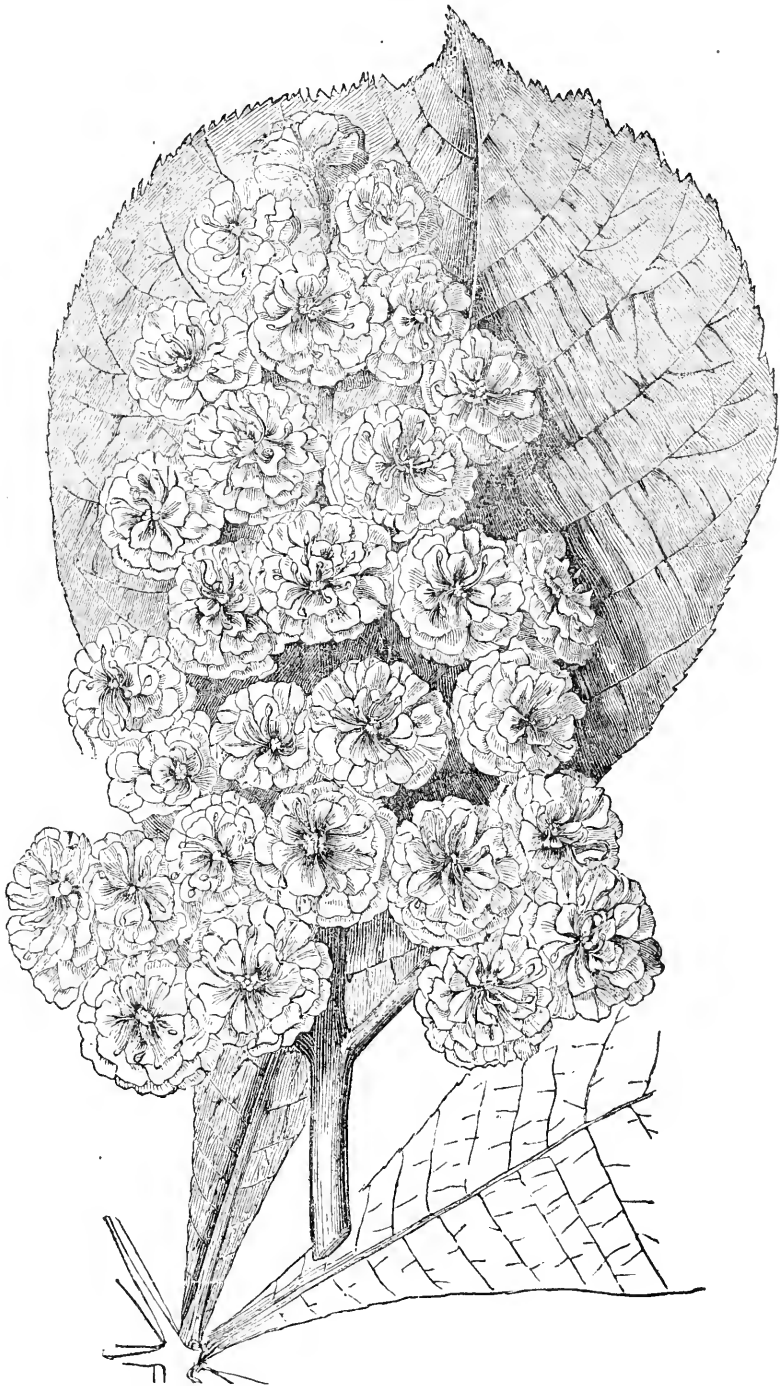

THE DOUBLE-FLOWERING WHITE HORSE CHESTNUT.

THE DOUBLE-FLOWERING WHITE HORSE CHESTNUT.—We copy the accompanying figure and description of this rare and beautiful variety of one of the most popular ornamental trees from the Gardener's Magazine. We had the pleasure of seeing some fine specimens of it abroad; the largest was in Mr. LE ROY's nurseries at Angers, France: it is some fifteen years old, and about as large as the common sort at that age in this country. It is easily propagated by grafting or budding on the common one, and will no doubt soon be had in our nurseries.

“*ESCLUSUS HIPPOCASTANUM FLOREPLENO.* Double flowered Horse Chestnut.—A rather uncommon and very ornamental tree, equalling in vigor the common sort, from which it differs only in its double flowers. These are very showy, having a strong resemblance to a good double hyacinth; they are pale blush, with deeper blush at the base of the petals. Our figure was made from a specimen communicated by Mr. RIVERS, nurseryman of Sawbridgeworth, who informs us that he ‘received it from the Continent some seven or eight years since.’ The spike of flowers we have represented was not as long as usual, owing to the tip having been killed by the frost in May. The trees flower when quite young.”

LARGE APPLES.—In our part of the country, large apples are by no means a novelty. Our *Twenty Ounces*, *Monstrous Pippins*, and *Pumpkin* apples, are so common that nothing short of the *wonderful* is really worthy of note. We think we have something before us that comes under that head; if not, it borders closely upon it at any rate. A specimen of the *Fall Pippin* we think, produced in the garden of AARON ERICKSON, Esq., of Rochester, measuring sixteen inches in circumference, and weighing twenty-six and one-half ounces. We cut this prodigious specimen and found it sound and good to the core, and of very fair quality. There grew on the same tree, another weighing twenty-five ounces, and two others nearly as large. It is a serious, if not a very dangerous matter to grow such apples. Suppose one of these should fall ten or fifteen feet, upon the head of a child, or even of a grown person? But Mr. ERICKSON does not apprehend any danger of this kind. The tree that produced these monsters is not over three feet high, and this will appear to those not accustomed to the culture of dwarf trees, no less remarkable than the size of the apples. We think Mr. E. may say that he has produced the largest apple on record, on the smallest tree. In all our experience, we have seen none, nor in reading have we seen any account of such large apples. The trees are some seven years planted, and are about ten years old. Mr. ERICKSON has also produced the largest and most beautiful specimens of the *Alexander* apple that we have ever seen, on dwarf trees, too. The crop on all his dwarf apple trees, the past season, has been remarkably fine, although on standard trees generally, it has been below the usual average. The dwarf pears, in the same garden, were, a few years ago, the finest in this country of their age, but the blight that prevailed here a few years past, made sad inroads upon them.

DESCRIPTIONS OF NEW PEARS.

BY B. DESPORTEZ, OF ANGERS, FRANCE.

The Alouette pear, (Fig. 1.)—Mr. ANDRE LE ROY found this variety in one of his nurseries on the farm at Sauge, near Angers. The tree has a pyramidal habit, of vigorous growth, and as a standard exceedingly productive—one of the most profitable for market. The farmer gathers annually 4000 fruits from this tree, weighing 400 lbs., or thereabout, and sells them for six or eight dollars, which, considering how cheap everything is in our country, is considered large profits, and few other kinds yield so much.

The fruit is small—about two inches long and one and three quarters in diameter. *Form*—turbinate, regular, surface uneven. *Stalk*—slender, one inch long, inserted on the surface. *Calyx*—large, broad, deep. *Color*, greenish yellow, sprinkled with gray dots and rosy spots on the sunny side. *Flesh*—breaking, white, juicy, sweet, and agreeably perfumed. Ripens beginning of September here. The hardness and productive-

ness of this variety make it very valuable as a standard orchard sort for the market. The fruit resembles very much the *Ah mon Dieu!* or *Abundance*, but ripens earlier.

The Barboucinet pear, (Fig. 2.)—This variety was discovered by Mr. ANDRE LE ROY at his nursery of Barboucinet on the farm of the same name. The tree is about 25 years old and 20 feet high, of medium vigor, branches slender and spreading—adapted to the standard form. The fruit is about three inches long and two inches in diameter, pyriform, irregular, surface uneven. *Stalk*—one-fourth of an inch long, stout, enlarged at both ends, fleshy at the base. *Calyx*—open, shallow, in a broad cavity. *Color*—green; when ripe, reddish spotted on the sunny side and gray or russeted every where, and especially around the stem; dotted over the surface with deep green points. *Flesh*—greenish white, tender, melting, buttery, and juicy, with a slight acidity. Ripens here beginning of Sept.

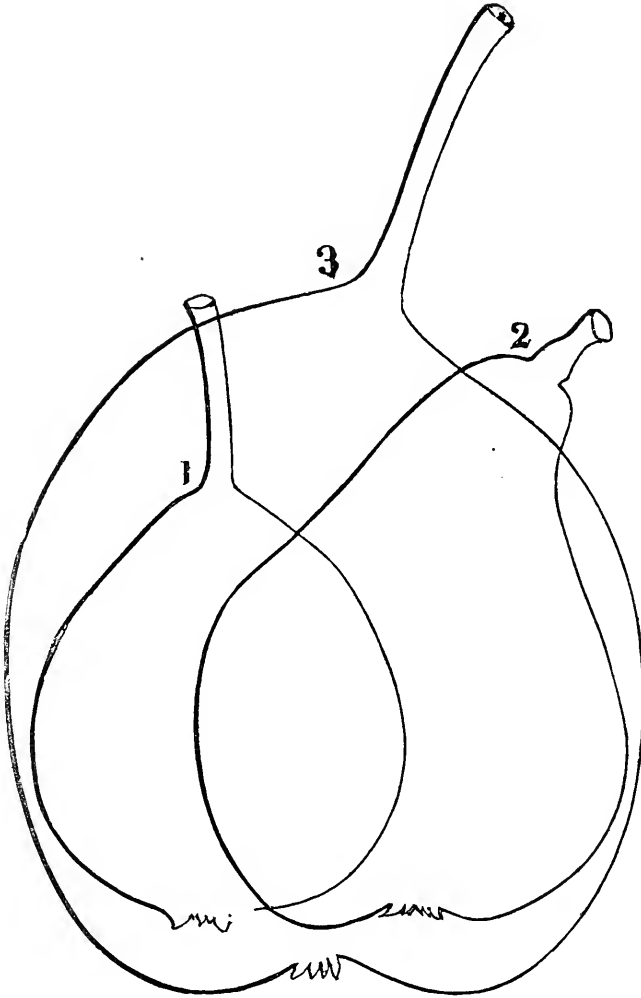

This is a first rate pear and very profitable for market. It is highly esteemed by the farmers, who prefer it to larger sorts. This season the tree has yielded about 600 fruits weighing 120 pounds, which makes a good profit even here where the great abundance of fruits make them very cheap.

The Bezy des Veterans pear, (Fig. 3.)—This is a very large fruit, nearly round, generally depressed on one side, near the stem. *Skin*—thick, gray, shaded with light yellow. *Flesh*—white, fine grained, firm, breaking, rather deficient in juice but sugary and greccable. It possesses the rare merit of keeping well till April and May. The tree is vigorous, well adapted to the pyramidal form, and is very productive.

We regret that M. DESPORTEZ has not given us a more full account of this variety. We have a few fine specimens on hand, and from appearances we are inclined to believe it will prove a valuable winter variety.

Ladies' Department.

VILMORIN'S FLOWER GARDEN AT PARIS.

THE following letter from Mr. BARRY, while in Europe, will be interesting, as showing the extent to which the raising of flower seed is carried in France, and the care taken to preserve all varieties in purity and perfection. We shall receive from this establishment a large collection of seeds, (probably some time in January,) and will distribute them among our female readers. So, fair lovers of flowers, send on your orders and we will furnish you a collection of flower seeds, without charge, so fine that all who pass by in summer may know where the Genesee Farmer is taken, by the beauty of the garden. We shall not be able to supply seed until February, but all applications are placed on file and will be attended to.

Among the many interesting gardens I have visited in and around Paris, none have pleased me more than the great flower garden of VILMORIN. It contains, I should think, between two and three acres, and is wholly, or *almost* wholly, devoted to the culture of annual flowers *for the seeds*. It is not laid out artistically like a flower garden, for it is in fact a flower *nursery*, laid out in rectangular beds four feet wide, with paths two feet wide between. At the entrance gate there is a well of enormous depth, (I forget the number of feet,) from which water is drawn, by a horse, into a great cistern, and thence conveyed by pipes into the various quarters of the garden and deposited in tanks, from which it can be applied liberally with very little labor. In very warm, dry weather, such as they frequently experience here in the months of July and August, the horse pumps, the water runs, and the men pour it on, *all day*. There can be no such thing as a *drouth* where this arrangement exists. I have already, in speaking of market gardens, alluded to the Paris system of watering and its effects. I have seen a great many nurseries; I think I can say I have seen the largest and the smallest, the worst and the best that exist, but I must decidedly call this flower nursery *the most beautiful*. I am just in time to see it—the finest things are in full bloom.

What a gorgeous display of *Dwarf Rocket Larkspur*, immense beds of it, every color, and every shade of color, by itself, red, white, purple, blue of various shades, and some beautifully striped like a carnation. They are indeed the glory of the garden. (I must say here, for the benefit of the more inexperienced, that this is not an annual, but a biennial flower, the seeds being sown one year and flowering the next.) Next in importance, in point of show just now, stand the *German Ten Week Stocks*. Like the *Rockets*, they are grown in great quantities, and every color and every shade is kept by itself with the greatest care and precision. Those who never see but the product of a paper of mixed Ten Week Stocks, can have no idea of the display that can be made with this flower. Here are dark purple, of a velvety richness; there are fiery scarlet; next we come to delicate lilacs, then flesh color, pure white, &c., &c., through all the richest, deepest, darkest, and most delicate tints. The seeds of all these colors of *Rockets* and *Ten Week Stocks* are carefully saved and put up separately. The *Balsamines* and *Asters* are prominent objects, but I am too early for them. Among the most striking species, I have noticed *Godetia rubicunda*, rosy purple, and *Godetia Lindleyana*, lilac with red spots. These are both fine, showy things. *Kalfussia Amelloides* has flowers of a rich, deep blue. The *Yellow Centaurea* is showy and fine. *Lobelia ramosus* and *erinus* are two slender dwarf growing plants that make charming masses. The *White Viscaria* is grown largely and makes fine masses. *Leptosiphon* (Gilia) *Androsacea* and *Densiflora*, are fine for the same purpose. I see an *Escholtzia*, nearly white; a very large, double, purple, *Gnaphalium* (everlasting flower); a beautiful yellow *Platystemon* from California; great beds of *Alstromerias* and *Mesembry anthemuns*. The tri-colored

variety of the latter is a great acquisition. The *Candytufts* are quite remarkable, especially the white rockets and deep purple. No grower of annuals should be without these. The *Convolvulus*, or Morning Glory, makes a fine show; the tricolor, or striped one, is very pretty. An *Argemone*, with prickly leaves, and large, showy, yellow blossoms, appears well. I might go on and cover pages with names.

It is not only in the rarity and variety of the flowers here that its greatest beauty consists, but in the wonderful luxuriance in which everything is growing. There are natives of many widely separated countries, and different climates, yet all are flourishing. This garden is but a small portion of the grounds of Messrs. VILMORIN & Co., devoted to Horticulture; they have several other gardens appropriated to other objects, but, just at this time, this is the most interesting.

Under the title of "*Vilmorin Albums*," this house publishes every year two great folio plates, lithographed and colored, one representing culinary vegetables of the natural size, and the other new and interesting flowers artistically grouped in a boquet. We had the pleasure of examining these Albums. They are kept in the office for the benefit of purchasers of new and rare articles. The seed catalogue of this establishment is prepared in the most skilful manner; and, besides, they issue a small, cheap work, which gives simple directions for the sowing of flower seeds and cultivation of them in the open air.

The house of Messrs. VILMORIN, ANDRIEUX & Co., is well known over all Europe, as well as in America. There is not, probably, in existence a more complete or better managed establishment of the kind. The proprietors are not mere merchants who know how to buy and sell, but they are profound botanists and skilful horticulturists, familiar with the flora of all explored countries and with the particular culture required by different species and tribes. M. LOUIS VILMORIN is at this moment one of the most efficient promoters of horticultural improvement in France. P. B.—*Paris, July, 1851.*

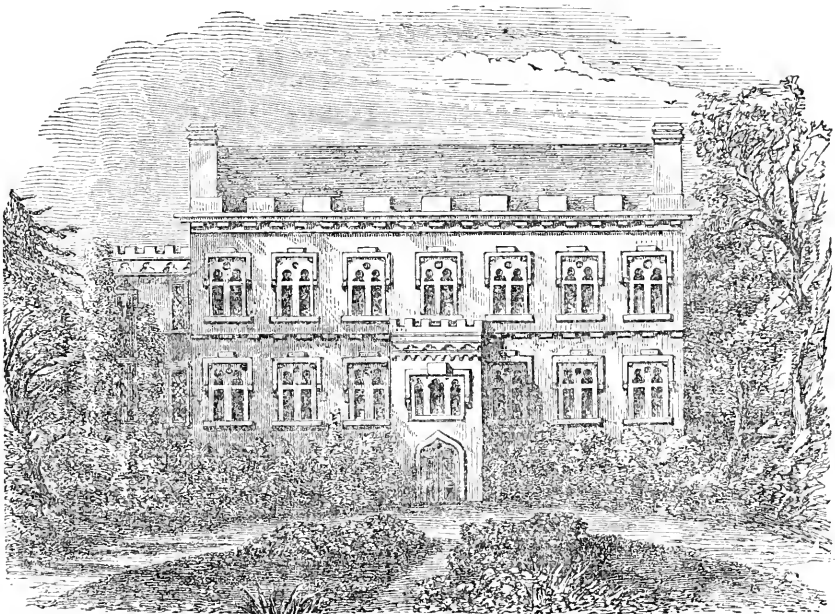

OTSEGO HALL.

RESIDENCE OF THE LATE J. FENNIMORE COOPER, COOPERSTOWN, N. Y. DRAWN BY MISS COOPER, AUTHOR OF "RURAL HOMES."

Youths' Department.

CENTER OF GRAVITY.

The following article on the *Center of Gravity* we take from an excellent paper in the Transactions of the New York State Agricultural Society, on *Agricultural Dynamics*, by J. J. THOMAS. It will prove both interesting and instructive to our youthful readers.

The *center of gravity* is that point in every hard substance or body, on every side of which the different parts exactly balance each other. If the body be a globe or round ball, the center of gravity will be exactly at the center of the globe; if it be a rod of equal size, it will be at the middle of the rod. If a stone or any other substance rest on a point directly under the center of gravity, it will remain balanced on this point; but if the point be not under the center of gravity, the stone will fall towards the heaviest side.

Every farmer who erects a wall or building; every teamster who drives a heavy load, or even he who only carries a heavy weight upon his shoulder, may learn something useful by understanding the laws of gravity.

If any body, of whatever shape, be suspended by a hook or loop at its top, it will necessarily hang so that the center of gravity shall be directly under the hook. In this way, this point in any substance, no matter how irregular its shape may be, is ascertained. Suppose, for instance, we have the irregular plate or board shown in the annexed figure, (fig. 1,) first hang it by the hook *a*, and the center of gravity will be somewhere in the dotted line *a b*. Then hang it by the hook *c*, and it will be somewhere in the line *c d*. Now the point *e*, where they cross each other, is the only point in both, consequently this is the center sought. If the mass or body, instead of being flat like a board, be shapeless like a stone or lump of chalk, holes bored from different suspending points directly downwards, will all cross each other exactly at the center of gravity.

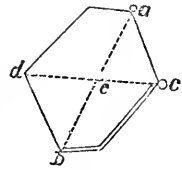

FIG. 1.

An imaginary line from the center of gravity perpendicularly downwards, to where the body rests, is called the *line of direction*.

Now, in any solid body whatever, whether it be a wall, a stack of grain, or a loaded wagon, the line of direction must fall within the base or part resting upon the ground, or it will immediately be thrown over by its own weight. A heavily and evenly loaded wagon on a level road will be perfectly safe, because the line of direction falls equally between the wheels, as shown in fig. 2, by the dotted line, *c* being the center. But if it pass a steep side-hill road, throwing the line of direction outside the wheels, as in fig. 3, it must be instantly overturned. If, however, instead of the high load represented in the figure, it be some very heavy material, as brick or sand, so as not to be higher than the dark



FIG. 2.

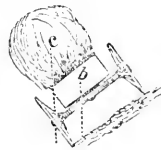

FIG. 3.

part of the figure, the center of gravity will be much lower down, or at *b*, and thus the line falling within the wheels, the load will be safe from danger, unless the upper wheel pass over a stone, or the lower wheel sink into a rut. The center of gravity of a large load may be nearly ascertained by measuring with a rod; and it may sometimes happen that by measuring the sideling slope of a road, all of which may be done in a few minutes, a teamster may save himself from a comfortless upsetting and perhaps heavy loss. Again, a load may be temporarily placed so much towards one side, while passing a sideling road, as to throw the line of direction considerably more up hill than usual,

and save the load, which may be adjusted again as soon as the dangerous point is passed. This principle also shows the reason why it is safer to place only light bundles of merchandize on the top of a stage coach, while all heavier articles are down near the wheels. When it becomes necessary to build very large loads of hay, straw, wool, or other light substances, the "reach," or the long connecting bar of the wagon, must be made longer, so as to increase the length of the load. For, by doubling the length, two tons may be piled upon the wagon with as much security from oversetting as one ton on a short wagon.

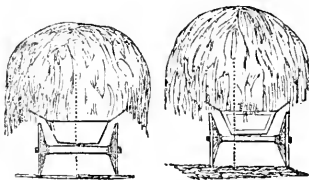

FIG. 4.

FIG. 5.

Where, however, a high load cannot be avoided, great care must be taken to have it evenly placed. If, for instance, the load of hay represented by fig. 4, be skillfully built, the line of direction will fall equally distant within each wheel. But a slight misplacement, as in fig. 5, will so alter this line as to render it dangerous to drive except on a very even road.

It is familiar to every one, that a body resting upon a broad base is more difficult to overset than when the base is narrow. For instance, the square block, fig. 6, and

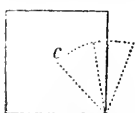

FIG. 6

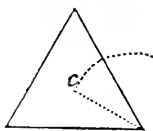

FIG. 7.

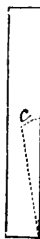

FIG. 8.

pyramid, fig. 7, are less easily thrown over, than the tall and narrow block of equal weight, fig. 8. Because, in turning the square block over its lower edge, the center of gravity must be lifted up considerably, in the curve shown by the dotted line; but with the tall narrow block, this curve being almost on a level, very little lifting is required.

Wheel-carriages owe their comparative ease of draught to the fact that the center of gravity in the load is moved forward, by the rolling of the wheels, on a level, or parallel with the surface of the road. Each wheel supports its part of the load at the hub. Hence, on a level road, the line of direction falls precisely where the wheels rest on the ground; but if the road ascend or descend, it falls elsewhere; hence the reason that it will run by its own weight down a slope. Whenever a stone or other obstruction occurs in a road, it

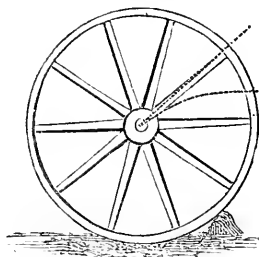

FIG. 9.

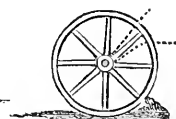

FIG. 10.

becomes requisite to raise the center of gravity by the force of the team so as to throw the wheel over it, as shown by fig. 9. One of the reasons thus becomes very plain why a large wheel will run more easily on a rough road than a smaller one, the larger one mounting any stone or obstruction without lifting the load so much out of a level, as shown by the dotted lines in the annexed figures, (figs. 9 and 10.) Another reason is, the large wheel does not sink into the smaller cavities in the road.

When a load is carried on the shoulder, it should be so placed that the line of direction may pass directly through the shoulder or back down to the feet, fig. 11. An inexperienced person will sometimes place a bag of grain as shown in fig. 12. The line falling outside his feet, he is compelled to draw downwards with great force on the other end of the bag. A man who carries a heavy pole on his shoulder should see that the center is directly over his shoulder, otherwise he will be compelled to bear down upon the lighter end, and thus add in an equal degree to the weight upon his shoulder.



FIG. 11.



FIG. 12.

Editor's Table.

OUR JANUARY NUMBER is now before you, kind reader, and it is a specimen of what we intend our paper shall be each month during the year 1852; differing only in this respect, that we design to make each number better than its predecessor. Already we have received largely increased clubs from many places, and our friends in all sections of the country are doing even more perhaps, than we had a right to expect. Without such generous aid from the friends of RURAL PROGRESS, we could not furnish the GENESEE FARMER at such a low price; with it, we intend to give our readers at least one of the best agricultural papers in the world, for the small sum of THREE SHILLINGS a year to clubs of eight or more.

We invite all to show this number to their friends, and we will supply extra numbers to those who wish them. We often receive letters inquiring on what conditions we send to clubs—whether all are required to be sent to the same office, &c. The *only rule* we have, is to send our Journal to clubs in such way and manner as will *best suit the convenience of our subscribers.*

AGRICULTURAL REPORT FROM THE PATENT OFFICE, FOR 1850.—This is a well filled volume of 579 pages, nearly all of which are occupied with original communications from over one thousand practical farmers residing in all the States of the Union, with one exception. Eight thousand circular letters were sent out from the Agricultural Department; and answers were received in return enough to fill two volumes of 1000 pages each. To re-write and condense this mass of generally badly written manuscript, so as to express its substance in one-fourth the words, and print it on 500 pages, was a labor which but few can appreciate. Under the circumstances of the case, it was impossible to do full justice to so many correspondents; but whoever will carefully read the Report from beginning to end, can hardly fail to find a great deal to instruct and interest him. Congress has ordered 120,000 copies to be printed and bound for general distribution, and no one should indulge the least hesitancy in writing to the representative in Congress from his district for a copy. The whole is already stereotyped, and if another 100,000 copies should be printed for gratuitous distribution over our thirty-one States and five Territories, it would cost only \$33,000 of the *fifty millions* now annually expended by Congress. The great farming interest shares less in the funds

of the General Government than any other, because farmers ask for nothing whatever. However the fact may be regarded by our readers, more than three-fourths of the fifty-two millions which will be paid into the National Treasury in the year 1851, will be dug from American soil, and far more to its injury than is generally believed.

The Report for 1850 does not contain the agricultural statistics of the U. S. Census of that year, for they were not collated and ready for the press. Among its essays is one of considerable length, on "*The Study of Soils*," from the pen of the proprietor of this journal. Of the merits of this performance it does not become us to speak; but we do not hesitate to commend a paper written by Mr. J. J. THOMAS, of Macedon, N. Y., on "*Fruit Culture*," a valuable contribution to our popular literature on that subject. The aim in preparing the document, has been to make it useful to plain, practical farmers, and not one line has been inserted for show. Farmers are its authors, and they will know how to estimate its value.

Our friends ordering the Farmer will be particular in giving the name of the Post Office, County, and State; also, in writing names plain, as by this much perplexity may be avoided to ourselves and subscribers.

TERMS—FIFTY CENTS a year for single copies; *five copies* for \$2, being *forty cents each*; and *eight copies* for \$3, being *three shillings each*, and any greater number at the same rate.

MANY articles, some of them in type, we are compelled to omit; among them several answers to inquiries, which will appear in our next.

Inquiries and Answers.

CURE FOR GARGET IN COWS.—Your subscriber, Mr. GREAVES, inquires for a cure for Garget in cows. For the benefit of Mr. G. and others, I would say that a piece of poke root (or skoke root, as it is sometimes called,) the size of a walnut, given in a potato or apple occasionally, will cure. Give three mornings, and skip three, until a cure is effected.

For a preventative, give your cows a little salt-petre with their salt, say two pounds to a bushel of salt. *Oneida Lake, Nov., 1851.*

A strong decoction of smart weed applied to the udder will assist in the cure. We have received nearly a score of letters in answer to the inquiry on this subject, all nearly similar to the above.

BOTS AND COLIC IN HORSES.—Myself, as well as others, would be pleased to see some of the best remedies (those that can be relied on,) for the Bots or Grubs, and the Colic, in horses. We are much perplexed sometimes to know how and what to administer for the relief of that noble animal. EDW. L. COKE.—*Burnt Ordinary, Va., 1851.*

We have no doubt that many horses have been doctored for the Bots, and perhaps some have died under the treatment, while others have recovered in spite of it, when colic, constipation, inflammation of the bowels, or some other disease, has been the cause of all the difficulty. "Bots" is a favorite theme with horse doctors of more pretensions than knowledge. The best English authorities agree in stating that the Bots is never injurious to the horse, causing no disease, or even symptoms of disease, while others claim that they are injurious. But even if this is so, we hardly know how the insect is to be dislodged from the stomach, for COLE says they have lived in rum twenty-four hours, a decoction of tobacco eleven hours, spirits of turpentine forty-five minutes, and in brine ten hours, without any effect. Their entering the stomach may be prevented to some extent by rubbing the parts where the eggs are observed, with a cloth and warm water, or applying grease or oil. To make the matter plain, we copy the full description and engraving, showing the fly, the egg, and the bots as they are attached to the stomach, from YOUATT's work on the Horse:

"In the spring and early part of the summer, horses are much troubled by a grub or caterpillar, which crawls out of the anus, fastens itself under the tail, and seems to cause a great deal of itching or uneasiness. Grooms are sometimes alarmed at the appearance of these insects. Their history is curious, and will dispel every fear in regard to them. We are indebted to Mr. Braey Clark for almost all we know of the bot.

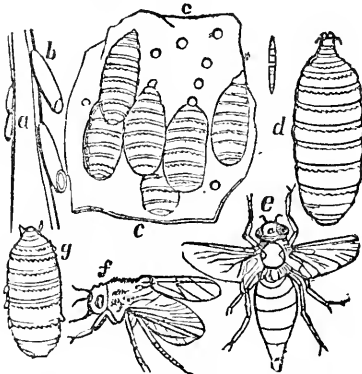

a and *b*, the eggs of the gad-fly adhering to the hair of the horse.

c, The appearance of the bots on the stomach, firmly adhering by their hooked mouths. The marks or depressions are seen which are left on the coat of the stomach when the bots are detached from their hold.

d, The bot detached.

e, The female of the gad-fly, of the horse, prepared to deposit her eggs.

f, The gad-fly by which the red bots are produced.

g, The smaller, or red bot.

"A species of gad-fly, *e*, the *oëtrus equi*, is in the latter part of the summer exceedingly busy about the horse. It is observed to be darting with great rapidity towards the knees and sides of the animal. The females are depositing their eggs on the hair, and which adhere to it by means of a glutinous fluid with which they are surrounded (*a* and *b*). In a few days the eggs are ready to be hatched, and the slightest application of warmth and moisture will liberate the little animals which they contain. The horse in licking himself touches the egg; it bursts, and a small worm escapes, which adheres to the tongue and is conveyed with the food into the stomach. There it clings to the cuticular portion of the stomach, *c*, by means of a hook on either side of its mouth; and its hold is so firm and so obstinate, that it must be broken before it can be detached. It remains there feeding on the mucus of the stomach during the whole of the winter, and until the end of the ensuing spring; when, having attained a considerable size, *d* and being destined to undergo a certain transformation, it disengages itself from the cuticular coat, is carried into the villous portion of the stomach with the food, passes out of it with the chyme, and is evacuated with the dung.

"The larva or maggot seeks shelter in the ground, and buries itself there; it contracts in size, and becomes a chrysalis or grub, in which state it lies inactive for a few weeks, and then, bursting from its confinement, assumes the form of a fly. The female, becoming impregnated, quickly deposits her eggs on those parts of the horse which he is most accustomed to lick, and thus the species is perpetuated.

"There are several plain conclusions to be drawn from this history. The bots can not, while they inhabit the stomach of the horse, give the animal any pain, for they have fastened on the cuticular and insensible coat. They cannot stimulate the stomach, and increase its digestive power, for they are not on the digestive portion of the stomach. They cannot, by their roughness, assist the trituration or rubbing down of the food, for no such office is performed in that part of the stomach—the food is softened, not rubbed down. They cannot be injurious to the horse, for he enjoys the most perfect health when the cuticular part of his stomach is filled with them, and their presence is not even suspected until they appear at the anus. They cannot be removed by medicine, because they are not in that part of the stomach to which medicine is usually conveyed; and if they were, their mouths are too deeply buried in the mucus for any medicine, that can be safely administered, to affect them; and, last of all, in due course of time they detach themselves and come away. Therefore, the wise man will leave them to themselves, or content himself with picking them off when they collect under the tail and annoy the animal.

"The smaller bot, *f* and *g*, is not so frequently found.

"Of inflammation of the stomach of the horse, ex-

cept from poisonous herbs, or drugs, we know little. It rarely occurs. It can with difficulty be distinguished from inflammation of the bowels; and in either case the assistance of the veterinary surgeon is required."

The English remedy for colic, is turpentine, opium, and aloes, given in warm strong beer—4 drams of aloes, 1 oz. of turpentine, 1 oz. laudanum, in 1 pint of beer. YOUART says this will generally cause the disease to cease almost as suddenly as it appeared. If the disease should not yield speedily, he recommends bleeding to prevent inflammation. The belly should be well rubbed with a brush or warm cloth, and clysters of warm water should be injected. We have already devoted so much space to this article, that we can not say more of the colic in this number, but may in our next.

PREPARING BONES FOR MANURE.—I wish to gain information through the columns of your excellent paper, as to the best mode of using bones as a manure; also of preparing them for use. By doing so, you will oblige A SUBSCRIBER.—*Adams Center, N. Y., 1851.*

We have on file several inquiries similar to the above. We shall endeavor to answer one and all. Bones should be crushed to fragments before being applied to the land, otherwise they decay very slowly. Ten bushels of crushed bones will show a better effect, for many years, than one hundred bushels uncrushed. It is no uncommon thing in England to see a double crop of turnips as the effect of the application of bone dust, even twelve years after its application. Bones, if well seasoned, can be ground in a plaster mill. We have known them to be kiln-dried for this purpose. If they are fresh, the work of crushing can better be done at an oil mill.

Another mode of preparation is to boil the bones in a strong lye until they fall to a powder, then mix the lye and bones with fine dry loam. After the water has evaporated, the mixture may be drilled in with wheat, turnips, and other crops; or sown broadcast. A small quantity of bones applied in this way, produces surprising effects.

Still another method of preparing bones is to dissolve them in a solution of oil of vitriol. Two bushels of bone dust dissolved in vitriol, will produce a greater effect the first year than twelve applied as dust. Sulphuric acid (oil of vitriol) costs but from 2½ to 3 cents per pound. We give the process in detail, in the words of Professor NORRIS:—"To every 100 lbs. of bones, about 50 to 60 of acid are taken; if bone dust is used, from 25 to 45 lbs. of acid is sufficient. The acid must be mixed with two or three times its bulk of water, because if applied strong it would only burn and blacken the bones without dissolving them.

"1. The bones are placed in a tub, and a portion of the previously diluted acid poured upon them. After standing a day, another portion of acid may be poured on; and finally the last on the third day, if they are not already dissolved. The mass should be often stirred.

"2. Another good way is to place the bones in a heap upon any convenient floor, and pour a portion of the acid upon them. After standing half a day, the heap should be thoroughly mixed, and a little more acid added; this to be continued so long as necessary. It is a method which I have known to prove very successful.

"In either case the bones will ultimately soften and dissolve to a kind of paste; this may be mixed with twenty or thirty times its bulk of water, and applied to the land by means of an ordinary water cart. Used in this way, it produces a wonderful effect upon nearly all crops.

"A more convenient method in most cases is to thoroughly mix the pasty mass of dissolved bones with a quantity of ashes, peat earth, sawdust, or charcoal dust. It can then be sown by hand, or dropped from a drill machine. Two or three bushels of these dissolved bones, with half the usual quantity of yard manure, are sufficient for an acre. This is therefore an exceedingly powerful fertilizer. One reason for its powerful effect is, that the bones are, by dissolving, brought into a state of such minute division, that they are easily and at once available for the plant. A peculiar phosphate of lime is formed, called by chemists a *superphosphate*, which is very soluble; and in addition to this we have the sulphuric acid, of itself an excellent application to most soils."

TO PREVENT HOGS ROOTING.—I saw in a number of the *Prairie Farmer*, a short time ago, an article stating that by cutting the tendons (or some other term,) that supports the rim of a hogs nose, it destroys their properties of rooting, without injuring the hog. If this is the case, and you could and would let me know how it can be done, you would oblige me, and probably a good many of the readers of the *Genesee Farmer*. H. JENNINGS.—*Wycocena, Wis., 1851.*

We have never seen the experiment tried of cutting the nasal tendon, or stout muscle on the top of a pig's nose, to prevent his rooting. The probability is that the remedy will prove successful. It operates on the principle of "ham-stringing." Cut square across the top of the nose a little back of the rim.

WEEVIL.—The insect contained in a letter from J. D. DAVIS, of Reading Center, N. Y., was so compressed and broken, that all we can say is that it was a fly and not a weevil. We will give some account of this insect soon.

LEACHED ASHES AND ROTATION OF CROPS.—Are leached ashes that have laid from thirty to fifty years exposed to the weather, worth hauling five miles as a fertilizer? If so, how should they be applied?

The following system of rotating crops, I have adopted, and thus far with an increase both in quantity and quality. Think you the advantage will be lasting? For wheat, I have three lots: one of which I summer fallow, another take a crop of wheat from, and the third I pasture—always seedling with clover, and applying about two hundred bushels of plaster to the acre. As I summer fallow the lot which I pastured the preceding year, I have a good turf and a heavy crop of clover to turn under. I do not calculate to pasture my fallow till after it is broken, but it is hard sometimes to keep the cows out. For other crops I have no system, only that I plow and grow three crops of different kinds—then seed, plaster, and manure, for meadow or pasturing, three years. A SUBSCRIBER OF THE TOWN OF G.

On good roads it will pay to haul leached ashes five miles; they should, however, be mixed with lime before their application, unless the soil abounds in calcareous matter. Eventually, your wheat and clover rotation will exhaust your land, if you do not renovate it occasionally with manure or ashes, to restore potash and bone earth removed in the seeds of wheat.

Clover draws the earthy ingredients from the subsoil for the benefit of wheat plants; but the supply will not last a century without adequate restitution. Beware of "clover-siek" fields.

GAS LIME.—Will you be so kind as to inform me of what value the gas limes are to put on to land to grow fruit trees, that needs lime in some form or other. At this place I can obtain stone lime, fresh and fine, for \$10 per hundred bushels. At the gas works in this city, they have a large quantity of lime that they have used for purifying the gas, and which was the best of the Onondaga lime, which they will sell cheap. There is no one here to tell me about it, and not seeing any article in the Farmer, I write you that I may get some correct information.

The soil is a strong clay loam that has produced wheat twenty-five years with only two or three crops of clover, which now yields about twenty-five bushels to the acre. But as I am to put it to different purposes, I thought I had better supply some of the phosphates first. It is troubled with grubs—the larvae of the May bug, or a large white grub with brown head—that gnaw the roots of small trees till they die. I have lost \$500 worth of plants this year by its depredations. To destroy this insect would be gratifying to me. I have sown thirty bushels of salt to the acre, and plowed it under. I intend to plow it again, following with the subsoil plow, that I may make the soil sixteen inches in depth.

Now, for manure we shall use muck from a swamp, that has been sweetened with lime and salt, adding some plaster to supply the sulphur.

I will close this letter, which is much longer than I intended to write at first, but I feel that I am excused when I read some of the interesting articles on the relation of science to agriculture that may be found in your paper. CHARLES P. COWLES.—Syracuse, N. Y., Oct., 1851.

There is more or less organized nitrogen in the coal from which gas is made, and the lime used to purify it usually contains ammoniacal compounds which, so far as they are present, are far more valuable for agricultural purposes than lime itself. Buy the gas lime as cheap as you can, and test its value by careful experiment.

MULES.—Will some of your correspondents inform me through the columns of your valuable paper, why mules are not reared to a greater extent in this State. It is stated that they are very profitable, easily reared, and a ready sale at two years old, at prices ranging from \$75 to \$100 each. K. —Oncida Lake, N. Y., Nov., 1851.

HORTICULTURAL.

(R. L. C., King's Ferry, N. Y.) The *Filberts*, *Madeira nuts*, and *Almonds*, of the shops will grow if sound and fresh. Sow in the fall, in any good, dry, friable soil, cover two inches deep. If you cannot plant in the fall, lay them in a thin layer in the ground, and cover with earth three or four inches deep till spring. *Doucain and Paradise Stocks* are not raised from seed, but layers; most of those used in this country are imported. *Mahaleb* seeds can scarcely be procured in this country, but the stocks can in the nurseries.

(F. S., King's Ferry.) The various kinds of dwarf stocks can be obtained in the nurseries here, at \$2 to \$3 per 100. *Mazzard cherry* and *Pear stocks* can be obtained at prices you will find in the nurserymen's catalogues. *Spanish chestnuts* are not to be had here; young plants can.

(S. W. R.) The "Fruit Garden" is sold at \$1.25, and the postage to you would be 20 cts. if pre-paid. The present postal law is unfavorable to the transmission of books by mail.

Will you be so kind as to answer a few inquiries in the Genesee Farmer, and oblige a subscriber.

1. Does the Angers Quince produce fruit superior to the Orange or Portugal?

2. Is the Striped Madelaine Pear tree as hardy and productive as the Madelaine? Does it succeed well on Quince?

3. Is it better to whip-graft Quince stocks with pears that have failed the first season to grow from bud, and transplanted in the fall again, than wait until the next fall and bud again? S. B.—Susquehanna Co., Pa., Nov., 1851.

1. We have not yet fruited the Angers Quince, but it is spoken of by cultivators of Angers as being very good.

2. The Striped Madelaine pear is, according to our experience, as hardy as the common one, but not quite so vigorous. It is productive and succeeds well on the quince.

3. You may get a tree sooner by grafting next spring the stocks on which the buds have failed the past summer, but you will have better trees in the end, if you wait and bud them next season, especially if they be transplanted. If intended to graft, they ought not to have been transplanted.

THE NURSERY BUSINESS IN IOWA.—A correspondent writes us from Maquoketa, Iowa—"There is one great drawback to the nursery business here, and that is *winter killing*. There is not more than one-third the varieties of apples that will stand root-grafting in this latitude, 42½ deg. Some nurserymen have lost thousands of dollars by it."

Will some of our friends in the west, who have tested the hardiness of varieties in climates similar to Jackson county, Iowa, communicate some of their experience. This matter touches upon a subject of great importance to the fruit growers of this country, viz., the *adaptation of varieties to certain climates and localities*.

CHARLES SCRIBNER, NEW YORK,

HAS JUST PUBLISHED

RURAL HOMES, Or Sketches of Houses suited to American Country Life. With over 70 Original Plans, Designs, &c. By GERVASE WHEELER. 1 Vol. 12 mo. Price \$1.25.

"It commences with the first foot-tread upon the spot chosen for the house; details the considerations that should weigh in selecting the site; gives models of buildings differing in character, extent, and cost; shows how to harmonize the building with the surrounding scenery; teaches how to healthfully warm and ventilate; assists in selecting furniture and the innumerable articles of utility and ornament used in constructing and finishing; and concludes with final practical directions, giving useful limits as to drawing up written descriptions, specifications and contracts.

"In this neat and tasteful volume, Mr. Wheeler has condensed the results of an accomplished training in his art, and the liberal professional practice of it.

"The cost of such establishments is carefully considered, no less than the comforts they should afford, the display they can (honestly) pretend to, and all the adjuncts that go to complete the ideal of a convenient and elegant mansion.

"We can confidently recommend this elaborate production to the attention of gentlemen who are about building or renovating their country houses, to professional architects, and to all readers of discrimination, who wish to know what is truly eloquent in this beautiful art, and to cultivate a taste worthy to cope with judgment of wisest censure."—*N. Y. Evening Mirror*.

"It is extremely practical, containing short, simple and comprehensive directions for all wishing at any time to build, being in fact the sum of the author's study and experience, as an architect, for many years."—*Albany Spectator*.

"Mr. Wheeler's remarks convey much practical and useful information, evince good taste and a proper appreciation of the beautiful, and no one should build a rural home without first hearing what he has to recommend."—*Phil. Presbyterian*.

"Important in its subject, careful and ample in its details, and charmingly attractive in its style—it gives all the information that would be desired as to the selection of sites, the choice of appropriate styles, the particulars of plans, materials, fences, gateways, furniture, warming, ventilation, specifications, contracts, &c.; concluding with a chapter on the intellectual and moral effect of rural architecture."—*Hartford Religious Herald*.

THE FRUIT GARDEN. THIRD EDITION. A Treatise intended to illustrate and explain the Physiology of Fruit Trees, the Theory and Practice of all operations connected with the Propagation, Transplanting, Pruning, and Training of Orchard and Garden Trees, as Standards, Dwarfs, Pyramids, Espaliers, &c., the laying out and arranging different kinds of Orchards and Gardens, the selection of suitable varieties for different purposes and localities, gathering and preserving Fruits, Treatment of Disease, Destruction of Insects. Descriptions and Uses of Implements, &c., illustrated with upwards of one hundred and fifty figures, representing different parts of Trees, all Practical Operations, Forms of Trees, Designs of Plantations, Implements, &c. By P. BARRY, of the Mount Hope Nurseries, Rochester, New York. 1 vol. 12 mo.

"It is one of the most thorough works of the kind we have ever seen, dealing in particular as well as generalities, and imparting many valuable hints relative to soil, manures, pruning and transplanting."—*Boston Gazette*.

"A mass of useful information is collected, which will give the work a value even to those who possess the best works on the cultivation of fruit yet published."—*Evening Post*.

"His work is one of the completest, and, as we have every reason for believing, most accurate to be obtained on the subject."—*N. Y. Evangelist*.

"A concise manual of the kind here presented has long been wanted, and we will venture to say that, should this volume be carefully studied and acted upon by our industrious farmers, the quantity of fruit in the State would be doubled in five years, and the quality, too, greatly improved. Here may be found advice suited to all emergencies, and the gentleman farmer may find direction for the simplest matters, as well as those which trouble older heads. The book, we think, will be found valuable."—*Newark Daily Advertiser*.

"It is full of directions as to the management of trees, and buds, and fruits, and is a valuable and pleasant book."—*Albany Evening Journal*.

"The work is prepared with great judgment, and founded on the practical experience of the Author—is of far greater

value to the cultivator than most of the popular compilations on the subject."—*N. Y. Tribune*.

"This book supplies a place in fruit culture, and that is saying a great deal, while we have the popular works of Downing, Thomas, and Cole. Mr. Barry has then a field to himself which he occupies with decided skill and ability."—*Prairie Farmer*.

New York, Jan. 1, 1852.

Fruit Scions for 1852.

THE subscriber will furnish Scions for this season's grafting, of the celebrated fruits of Western New York:

APPLE.

Northern Spy,
Norton's Melon,
Wagener,
St. Lawrence,
Canada Red,
Sugar,
Baldwin,
Pomme Grise,
Seek-no-further,
Hertfordshire Pearmain,
Fameuse,
Bourassa,
Twenty Ounce Apple,
Hawley, or Douce,
Gravenstein,
Bailey Sweeting.

Ribstone Pippin,
Summer Rose,
Rumbo,
Esopus Spitzenburgh,
Yellow Bullflower,
Roxbury Russet,
Early Harvest,
Early Strawberry,
Autumn Strawberry,
Early Joe,
Full Pippin,
Holland Pippin,
Rhode Island Greening,
Tulman Sweeting,
Green Sweeting
Porter,

PEARS.

Virgaltien,
Seckel,
Swan's Orange, or Onondaga,

Bartlett,
Oscego Beurree,
Brown Beurree,
Osband's Summer

and most of the Foreign varieties.

Apple Scions \$1.00 per 100, and Pear Scions Three Shillings per dozen. They will be carefully packed and sent by Express or by Mail. A discount on apple scions will be made to nurserymen.

Early orders are requested, to insure a supply. Address me (post-paid) at Rochester, Monroe Co., New York.

JAMES H. WATTS.

N. B.—In all cases where it is possible, I will send samples of the "Northern Spy" apple. Reference can be made to Mr. Vick, of the "Farmer."
Rochester, Jan., 1852.

McCormick's Reaping Machine.

THE undersigned has been appointed sole agent in New York, for the sale of McCormick's Patent Reapers and Mowing Machines. Farmers and others desirous of purchasing these celebrated machines, are requested to forward their orders at an early date, that they may be supplied in due time. These machines received the Gold Medal at the World's Fair, also, the first premium at every Fair in the United States, where they have been exhibited.

A. LONGETT,

At the State Agricultural Warehouse, No. 25 Cliff street.
New York, Jan., 1852.

Osage Orange for Hedges.

WE can furnish any number of fine yearling plants at \$1.50 per 100, or \$10 per 1000, or at \$8 where 3000 or more are taken. Orders should be sent early. It takes about 32 plants to the rod, planted either in single rows at six inches apart, or in double rows a foot apart—either of which makes a good hedge.

ELLWANGER & BARRY,

Rochester, N. Y., Jan., 1852.

50,000 Apple Stocks Wanted.

TEN TO FIFTY THOUSAND Seedling Apple Stocks, of thirty two years' growth, are wanted and will be paid for in Cash. Apply, or send samples, with price, immediately, to

JAMES VICK, Jr.
January 1, 1852. Genesee Farmer Office.

Winter Exhibition of Fruit.

It is proposed to have a meeting, at Mr. Fogg's Seed Store, on Saturday, 17th January, 1852, for the purpose of having an Exhibition of Winter Fruits. It will be remembered that such an one was held last January, which resulted in a fine show. The Growers of Fruit in Monroe, and all other counties, are requested to be present with specimens, which, after exhibition, will be sent to Albany for a like exhibition before the State Society, at their annual meeting on the 20th January.

The Practical and Scientific Farmer's own Paper.

THE GENESEE FARMER,
A MONTHLY JOURNAL OF
AGRICULTURE AND HORTICULTURE,
ILLUSTRATED WITH NUMEROUS ENGRAVINGS OF
Farm Buildings, Domestic Animals, Implements, &c.

VOLUME XIII, FOR 1852.

DANIEL LEE & JAMES VICK, JR., EDITORS.
P. BARRY, Conductor of Horticultural Department.

Fifty Cents a Year, in Advance.

Five Copies for \$2—Eight Copies for \$3, and any larger number at the same rate.

All subscriptions to commence with the year, and the entire volume supplied to all subscribers.

Subscription money, if properly enclosed, may be sent (post-paid or free) at the risk of the Publisher. Address to

DANIEL LEE,
December, 1851. Rochester, N. Y.

CONTENTS OF THIS NUMBER.

Agricultural Chemistry,.....	9
European Agricultural Statistics,.....	12
The Wintering of Stock,.....	13
Rural Homes,.....	16
Wine Making,.....	17
Side-Hill Barn,.....	20
Plowing in Clover,.....	21
Report made to the Central Ag. Society of Paris, upon the different Maladies existing in Wheat in France,.....	22
Agricultural Implements at the Great Exhibition,.....	22
LADIES' DEPARTMENT.—Vilmorin's Flower Garden at Paris,.....	31
YOUTHS' DEPARTMENT.—Center of Gravity,.....	33
EDITOR'S TABLE.—Agricultural Report from the Patent Office; Answers to Inquiries; Notices, &c.,.....	35

HORTICULTURAL DEPARTMENT.

Dwarf Fruit Trees,.....	26
The Double-Flowering White Horse Chestnut,.....	29
Large Apples,.....	29
Descriptions of new Pears,.....	29

ILLUSTRATIONS.

Two figures illustrating Wine Making,.....	19
Side-Hill Barn,.....	21
One Horse Farm Till Cart,.....	23
Liquid Manure Cart,.....	24
Tumble Cart in a position for traveling,.....	25
Double-Flowering White Horse Chestnut,.....	29
The Alouette, Barboucinet, and Bezy des Veterans pears,.....	30
Osage Hall,.....	32
Twelve figures illustrating Center of Gravity, &c.,.....	34
The Bot,.....	36

American Agricultural Book Depot.

CONSTANTLY on hand all the principal Agricultural and Horticultural Books, Magazines, &c., together with all works on kindred subjects— Architectural, Mechanical, and Scientific Books.

N. B.—Orders for any books published in this country, on any of the above subjects, may be made by mail to me, and they will be furnished at Publishers prices.

Agricultural School Libraries made up, at \$5, \$10, \$15, or \$20 and upwards, to suit purchasers.

Catalogues sent gratis on application by parties wanting books. Address **D. M. DEWEY,**

Arcade Hall, Rochester, N. Y.

Agents supplied at wholesale upon reasonable terms.

January, 1852.

50,000 Osage Orange Plants,
ONE YEAR'S GROWTH, price \$8 per 1000. No charge for packing or cartage, if 2000 or more are ordered.

OSAGE ORANGE SEED, at the lowest market price, wholesale or retail, as early in the winter as the new crop can be obtained from Texas. **M. B. BATEHAM,**
Columbus, Ohio. [1-4]

PROSPECTUS FOR 1852.

THE SATURDAY EVENING POST.
THE LEADING LITERARY WEEKLY OF THE UNION.

THE proprietors of the Post think it unnecessary to dwell upon the distinguishing features of their well known weekly, whose brilliant success during an existence of *Thirty Years* is a sure guarantee for the future. We have the pleasure of announcing our continued connection with that distinguished authoress, Mrs. E. D. E. N. SOUTHWORTH, Author of "The Deserted Wife," "Shannondale," &c.

During the coming year, we have already made arrangements for the following nouvelles: **EOLINE; OR MARYSOLIA VALE;** By Mrs. CAROLINE LEE HENIZ; author of "Linda," "Rena," &c. **VIOLA; OR ADVENTURES IN THE SOUTHWEST;** A Companion to "Prairie Flower," By EMERSON BENNETT, author of the "Prairie Flower," "The Bandits of the Osage," &c.

TIBAL AND TRIUMPH; By T. S. ARTHUR, author of "The Iron Hand," "Temperance Tales," &c. And last, but not least,

THE CURSE OF CLIFTON; A Tale of Expiation and Redemption. By Mrs. E. D. E. N. SOUTHWORTH, author of "The Deserted Wife," &c., &c.

The Post also will contain every week Selected Articles of the choicest description, One or More Engravings, Humorous Articles, the most Interesting News, Local News, Bank Note List, State of the Markets, the Stock Market, &c.

TERMS.—The Terms of the Post are two Dollars if paid in advance; Three Dollars if not paid in advance. For Five Dollars, *in advance*, one copy is sent three years. We continue the following low terms for Clubs, to be sent in the city to one address, and in the country to one post-office: 4 Copies,..... \$5 per year.
8 " (And 1 to agent, or getter-up of Clubs) 10 " "
13 " (And 1 to agent, or getter-up of Clubs) 15 " "
20 " (And 1 to agent, or getter-up of Clubs) 20 " "

The money for Clubs must always be sent in advance. Subscriptions may be sent at our risk. When the sum is large, a draft should be procured if possible—the cost of which may be deducted from the amount.

Address (always post-paid),

DEACON & PETERSON,

No. 66 South Third Street, Philadelphia.

P. S.—A copy of the Post will be sent as a specimen to any one requesting it. [1-4]

The American Art Union—1851.

SUBSCRIBERS for the year 1851 will receive an elegant line Engraving from a celebrated American Picture, entitled "Mexican news," by Woodville. Also five smaller line Engravings, as follows:

- Harvesting, by Crossley.
- Bargaining for a Horse, by Mount.
- Mount Washing, by Reusset.
- Marion Crossing the Pedee, by Raney.
- Old '76 and Young '78, by Woodville.

Also, the Bulletins issued after the payment of subscription.

Also, a Share in the distribution of several hundred Paintings, pieces of Sculpture, and other works of Art, in December next. Subscriptions for annual membership, \$5.

Certificates of membership may be obtained of

D. M. DEWEY,

Honorary Secretary, Rochester, N. Y.

N. B.—Subscriptions for membership may be sent by mail to my address, and I will return Certificates and Bulletins, giving all the particulars of the Institution, for Rochester and vicinity, and pay all postages.

Nursery Catalogues.

A CATALOGUE of superb new Dahlias, Puchsias, Phloxes, Verbenas, and other rare and popular bedding plants for the coming spring, will be issued in February. Our Catalogues are sent gratis to all applicants, but as the new postage regulations prohibit the sending of Catalogues by mail, unless *pre-paid*, we must request the enclosure of Postage Stamps with applications.

GENERAL DESCRIPTIVE CATALOGUE.

For any distance not over 500 miles,.....	5 cents.
Over 500, and not over 1500 miles,.....	10 "
“ 1500 “ “ 2500 “.....	15 "
“ 2500 “ “ 2500 “.....	20 "
“ 3500 miles,.....	25 "

PELLWANGER & BARRY,

Mount Hope Nurseries, Rochester, N. Y.

January, 1852.

STEREOTYPED BY J. W. BROWN, ROCHESTER, N. Y.

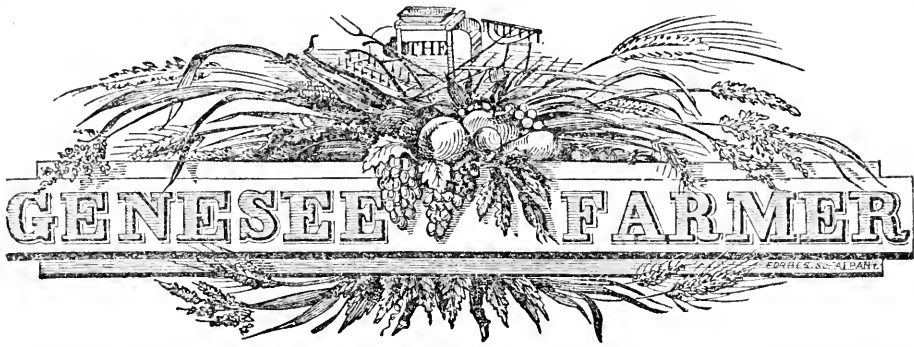

VOL. XIII.

ROCHESTER, N. Y., FEBRUARY, 1852.

No. 11.

AGRICULTURAL CHEMISTRY.

NUMBER II.

In the January number of the present volume we offered a few remarks on what was termed "an ever-active force in all matter, which tends to the formation of compound bodies." This force was also spoken of as some times "quiescent;" and the question naturally arises in the mind of the reader, how a power which is *ever-active* can be occasionally quiescent or inactive. This seeming contradiction is explained by stating that a chemical force is ever-active toward some bodies, while it is quiescent toward others. Thus, when iron and oxygen unite and form what is called the prot-oxide of that metal, the force or affinity that keeps these two elements together as a compound body, is ever-active; but in reference to most other bodies this force is entirely quiescent. If, however, a little vinegar be poured upon a simple compound of iron and oxygen, the acid and oxydized metal immediately form a chemical union, producing a salt called acetate of iron. In this phenomenon, it is known that the vinegar and the oxide of iron were each compound bodies, whose natural forces were active and brought them into a state of permanent union, so far as any chemical union can be permanent.

In the language of chemistry, all minerals that combine with acids are called *bases*; and different acids and bases, and other substances, have unequal affinities, which give rise to all the diversities that are found in the mineral, vegetable, and animal kingdoms. If each element in the material world were attracted equally toward all others, in a chemical sense, all bodies would be compounded alike, without the least variety in nature; and life would be impossible as we now see it, and all matter would be a perfect chaos again. To bring order and harmony out of confusion, it is safe to say that immutable laws to govern all possible changes in matter, are indispensable. The most superficial observation enables us too see the workings of these laws; and to no other class is their study more important than to the cultivators of the earth. In its application to tillage and husbandry, chemistry is so vast a subject that we hardly know how to give it a proper introduction to the reader. As we understand it, it is truly a revelation not only of the workmanship, but of the will of the Creator. The laws that govern the universe, and all its atoms, are his laws. To present rural science as illustrated by nature, in any other light, would do injustice alike to the Law-giver and the law-breakers. Man's very existence depends on physical laws, and these can not be separated from his duties, or moral obligations. Chemistry and religion are as close together as the world and its maker; or as the body of man and his reason and conscience. To impoverish the natural fruitfulness of the earth is to do mankind a great injury, without any excuse whatever. To avoid committing this wrong, a knowledge of the laws of Providence is indispensable. Ignorance of divine laws (and all chemical or

natural laws are divine in their origin,) may be a crime, and is generally a fault. Infinite Wisdom is not the friend of ignorance, but of knowledge; and the clergymen and pious persons who do not exert themselves to promote the universal study of chemistry and other branches of natural science, fall far short in their duty. Why continue a deep shade between the human soul and its God? Physical man must look through nature to see the Divinity beyond; and no one can diligently study natural phenomena, as the shepherds of old watched the constellations at night, and not become less an animal, and more a Man.

The extreme *divisibility* and perfect *solubility* of matter prepare and adapt it to the uses of the scientific husbandman in feeding his growing crops and growing animals. There are a thousand ways in which the extreme divisibility of solid matter may be demonstrated. If a particle of silver only the one-hundredth part of a line, or the twelve-hundredth part of an inch in extent, be dissolved in nitric acid, it will render distinctly milky 500 cubic inches of a clear solution of common salt. Hence the magnitude of each atom of silver can not exceed, but must fall far short of a billionth of a cubic line. To render the idea of this degree of division more distinct, says Sir ROBERT KANE, "it may be stated that, a man to reckon with a watch, counting day and night, a single billion of seconds, would require 31,675 years." In the organized kingdoms of nature even this excessive tenuity is far surpassed. An Irish girl has spun linen yarn so fine that a pound was 1432 miles in length, and of which, consequently, 17 lbs. 13 oz. would girt the globe. A distinctly visible portion of this thread could not have weighed more than the one hundred and twenty-seven-millionth of a grain; and yet each thread contained many fibres of flax, and each fibre was a mass of many cells, and each cell was composed of several distinct elementary bodies, such as carbon, oxygen, hydrogen, and the incombustible minerals which appear as *ashes* when flax is burnt. Microscopes have revealed organized creatures so small that it is said a million of them in one mass presents an object too small to be seen by the naked eye! Although we question the entire accuracy of this statement, yet, that animalculæ have a perfect organization, and their circulation of blood and its particles are as complex as those of the elephant, there can be no reasonable doubt. We should never forget that both the astronomer and the microscopist are indebted to art and science for the optical instruments that reveal planets and suns in the far off regions of the heavens, and living things in air and water, and their remains in rocks and mountains, before unknown. The divisibility of matter and its plasticity being comprehended, we are prepared to consider its solubility in water.

The laws which govern the solution of solids are not sufficiently known to admit of generalization. They are, however, resorted to in chemical researches and analyses, with eminent success. As was stated in the January number, the pulverization, or comminution of solids invariably promotes their solution in water; but why chalk will not dissolve, and why the muriate of lime will, are alike unknown. A critical knowledge of the relative solubility of different substances is exceedingly valuable to the chemist; nay, without this information, he can not be regarded as worthy of the title of chemist. Water is only one of many liquids used to dissolve both simple and compound bodies; acids, fused alkalies, ether, alcohol, and oils, are among the more common solvents, which are often aided by heat in the laboratory. Water, however, is now regarded as an universal solvent—dissolving all minerals when finely divided. Decaying vegetable and animal substances on the surface of the ground, yield carbonic acid and others to water, which greatly augments its solvent powers. It is sometimes charged with mineral acids, especially sulphuric, or the oil of vitriol. This acid is formed by the decomposition of iron pyrites, which is a compound of sulphur and iron. In this process the oxygen of the air or in water combines chemically with sulphur in the proportion of 24 parts of oxygen to 16 of sulphur. There are springs in Monroe county, N. Y., which contain sulphuric acid enough to render the water quite sour. Water charged with this

acid, no matter from what source, coming in contact with lime either in soils or rocks, produces gypsum. In some localities, crystalized plaster is formed so rapidly in the manner indicated, as to throw down, like frost, stone walls, and crack the walls of brick and stone buildings. When this phenomenon was first observed, much speculation was had "on the growing of beds of gypsum." Plaster can grow in soils and beds so long as lime and sulphur last, but no longer. Lime and sulphur are indispensable elements in all soils, and every farmer should be able to determine by the use of the appropriate tests, the existence of gypsum or lime in the land he occupies, whether in meadow, pasturage, or tillage. This information we shall give in the present volume, when we come to describe the analysis of soils. To the million, a knowledge of chemical principles is more important than any description of analytical manipulations, which not one in a thousand will ever practice. But many operations in the laboratory are so simple that any farmer may perform them with success, after a little study. If students in academies and advanced classes in public and private schools, were instructed in the uses of filters and solvents, to separate dissolved from undissolved substances, and in the application of reagents as tests in agricultural researches, an important step would be taken in the right direction. Because a youth can not reach the highest eminence in a science, there is neither sound sense nor decent logic in the inference, that he should make no effort to learn what he can of said science. Facts are the basis of all knowledge, and the habit of ascertaining and recording facts in rural affairs, both in practice and theory, should be encouraged from boyhood to old age. Apply the inductive system of reasoning and research to agriculture, and the tens of thousands of able men engaged in it will rapidly expose and correct the errors of the past, and enlarge the bounds of what is already known in tillage and husbandry.

Specific gravity are words used in chemistry to denote the relative weight of any given volume of a solid, liquid, or gaseous body. In all weights and measures, something is arbitrarily assumed as a *standard* with which other things are to be measured or weighed. Pure water, when the thermometer is at 32 deg., or at the freezing point, and the barometer at 30, furnishes a standard much used by chemists. Thus, a bottle that will hold an ounce (480 grains) of distilled water, will contain only 343 grains of sulphuric ether, which is much lighter than water. It will, however, hold 885 grains of oil of vitriol, or sulphuric acid. If we make water a unit, and place it at 1000, the specific gravities of ether and sulphuric acid will stand thus :

	<i>Grains. Sp. Gravity.</i>	
Water,	480	1000
Ether,	343	715
Sulphuric acid,	885	1845

To save the trouble of calculation, the bottle in use is generally made to hold 1000 grains of pure water, and then filling it with the fluid to be tried, the weight gives directly the specific gravity. By means of a light but more capacious glass globe, the comparative weight of gases is ascertained. A gas must be either perfectly dry, or saturated with moisture. Assume that the globe contains 28 cubic inches, and when filled with dry common air of a known temperature, (32 deg.,) weighed 656 grains. With the air removed, it might weigh 647.5 grains, showing a loss of 8.5 grains. Filled with dry carbonic acid at the same temperature, it would weigh 660.3. If we subtract the weight of the globe (647.5 grains) from the same filled with carbonic acid gas, the difference is 12.8, while that of common air is 8.5. Call the latter 1.000, and the specific gravity of carbonic acid gas is 1.506. Variations in temperature and barometric pressure change the relations of gases very materially.

How to determine the specific gravity of soils and other solids, will be explained in our next.

“THE LIMITED DURATION OF VARIETIES OF PLANTS.”

SINCE our article on this subject was written, the Horticulturist contains another from Mr. TOWNLEY, which the editor of that journal pronounces, not unjustly, “one of the most interesting it has published.” We have read the facts and argument of Mr. T. with close attention, and see no reason to alter the judgment we ventured to express in our last. The question is not whether seedlings, and plants, and trees, propagated by buds, will deteriorate, for it is generally conceded that both will, but whether a healthy bud from an aged tree, having equal advantages of soil and climate, may not live as long and do as well as a *new tree*, as one grown from a seed from the tree that produced the bud? Here is an apple tree, itself a seedling, which is one hundred years old; and the question to be decided is, what advantages for the production of a new tree have its seed over its buds? If the vital principle in its buds is feeble from great age, or a want of food, the same is true of its seeds. In cellular structure they are alike; and they are alike in composition and function after taking root in the ground.

How does it happen that seedling potatoes are subject to the rot as well as those grown from tubers, if the effect is confined to the propagation from tubers instead of seeds? We found it impossible to answer this question to our own satisfaction, and hence we doubted the soundness of the “bud theory” altogether. Seedling onions, carrots, and cabbages, often rot prematurely, especially so far south as Georgia. Indeed, they appear to decay there sooner than potatoes, even before carrots and onions are pulled. Had the plants produced from seeds, in starting new races of potatoes, been entirely exempt from the malady, while those cultivated from tubers were subject to it, such evidence would have gone far to show that nature had imparted less vital force to buds than to seeds. But, let seedlings be as long abused, in one form and another, as the tubers of potatoes and other plants have been, and also all fruits propagated by buds, and the seedlings so treated would show equal deterioration and proneness to early dissolution. It is better to have no theory at all on the subject of budded and seedling fruit trees, and esculent tubers, than one which, if not evidently erroneous, is more than doubtful. To improve all organic structures, all vital parts, one needs a knowledge of chemistry, anatomy, and physiology, in their application to the living beings whose constitutional vigor and enduring powers are to be changed for the better. Without considerable knowledge of the principles of organic chemistry, one cannot duly understand the relations that earth, air, and water, bear to cultivated plants, fruits, and animals; and without some acquaintance with their anatomy, some information in reference to the functions of their numerous organs, or their physiology, he cannot operate otherwise than in the dark in feeding his crops, his stock, and in improving his land. A man may produce, after a fashion, the flesh, bones, and feathers, of one hundred fowls or turkeys in a yard, without the remotest idea of the elements which nature demands and consumes in their healthy growth. Empiricism or accident may have given him valuable information on the subject; but where we meet with one person who really understands the art and science of manufacturing eggs and poultry in the most economical manner, we find ninety-nine who have the trade to learn. So it is in fruit culture, grain culture, potato culture, and grass culture.

Never, until farmers are willing to study the laws of nature which govern the organization, and the extension from generation to generation, of the plants and animals which they labor to produce, can they make substantial progress in their profession. The intelligent reader knows how little has been done in the United States to foster the critical study of every department of agriculture and horticulture. We depend on LOUDEN, KNIGHT, LINDLEY, LIEBIG, JOHNSTON, BOUSSINGAULT, and other Europeans, for nearly all our knowledge of rural science. Cannot original researches be made under a republican government as well as under monarchies?

CULTURE OF FLAX.

MAN of all animals is the only one who requires and is able to provide himself with clothing; and it is in direct proportion to his advancement in civilization and the arts, that he clothes himself with garments agreeable to the feelings and pleasant to the sight. The animal and the vegetable kingdoms furnish him with the raw material from which he makes his beautiful fabrics—the former supplying him with wool and silk, and the latter with cotton and flax. We propose to confine our attention at this time to the last.

Flax is supposed to have been brought originally from the alluvial soils of Egypt formed by the overflowing of the Nile, where from remote antiquity it has been cultivated, spun, and woven. Egyptian mummies embalmed 1200 years B. C. are found wrapped in swaddling clothes of fine *linen*. Its introduction from this warm to the colder climates, has materially improved the fibre and rendered it fitter for the manufacture of articles of fine texture. A cool, moist, and equitable temperature is best adapted to its growth, though it is grown at present to a greater or less extent in all the northern countries of Europe, in Italy, Sicily, Egypt, and to a considerable extent in Ireland and England, where great efforts have latterly been made by government to extend its culture so that it may afford employment for its superabundant labor. The amount now raised in Ireland is estimated at 25,000 tons. The total amount of flax consumed in the British isles is about 100,000 tons per annum. Of this Russia furnishes about 70 per cent.; but it is chiefly of a coarse texture, selling for about \$225 per ton, whereas Belgian is often sold from \$500 to \$700 per ton: it should therefore be the chief aim of the cultivator not so much to grow quantity but quality.

The soil best adapted for its growth, is a dry, deep loam, with a clay subsoil; and, as a general rule, all soils need under-draining for its profitable production. The preparation of the soil is of great importance. It should be quite free from weeds, and be finely pulverized to a considerable depth, as the fibrous roots of the flax plant, if they meet with no obstruction, often penetrate to a depth of thirty inches in a straight line. A good plan is to sow it after wheat. Directly after harvest, the wheat stubble should be dragged with a heavy harrow, which covers the small seeds, causing them to germinate. In about three weeks it should be well and deeply plowed: this will kill all the annuals that have germinated; but it should be dragged or cultivated at intervals in the fall, so as to destroy as many of the perennial roots as possible; and it would be advisable, as late in the fall as possible, if the weather be dry, to give it another deep plowing, so as to leave it *rough* for the winter. As soon as it is sufficiently dry in the spring, it should be dragged and rolled, and then immediately before sowing it should be again plowed, leaving the land as level as possible; a drag should precede the sower, and a light one with thick set teeth should be used to cover the seed.

The quantity of seed per acre is a matter of importance, depending on the condition of the soil and the object of the grower. If seed alone is the object, one bushel will be sufficient, as thin sowing causes the plant to throw out branches which bear abundance of seed, but the flax is of a very coarse, inferior kind. The richer the land the less seed is required, as the plant will branch more. But if *flax* is required, two and a half bushels (or 126 lbs.) is about the proper quantity. If the soil is rich, three bushels should be used; if poor, two bushels will be sufficient; the object being to prevent the plant from branching out and to obtain a tall and slender stem.

Great care should be taken to obtain *clean* seed. Choose that which is shining and slippery, not too plump, and of a brownish red color. It should be sown as early in April as the weather will permit; but it is better to wait till the soil is dry and warm, even if it should not be sown before the first of May.

The most critical time of the flax crop is before the plant has covered the ground—

dry weather and a hot sun often prove very injurious. The plant flowers about the middle of June, its delicate blue blossoms presenting a very beautiful appearance. Hail storms and heavy rains are now to be dreaded.

If the crop is grown entirely for the seed, it should be allowed to get fully ripe; but if flax is the object, experience proves that it should be cut or pulled before fully ripe; for although the seed will not be so full and plump, yet the increased fineness of the flax fully makes up for it. The Dutch method of ascertaining when it is ready to cut is as follows: "A full grown stem is selected, and the ripest capsule is cut horizontally with a sharp knife. If the interior of the seed pickles is found to be firm and of a dark green, the flax is considered fit for pulling."

In another number we propose a consideration of the best methods of preparing the flax for market, and also the most profitable way to dispose of the seed.

EXPERIENCE IN POTATO CULTURE.

BY A CORRESPONDENT AT JUNCTION, ILL.

By your leave I will give you a portion of my experience for the past season. On some high ground, level and rather worn, well manured and plowed the previous fall, and plowed again immediately before planting, I marked out a piece five rods square, and on the 23d of May planted it with potatoes. (Carters,) in drills about two feet nine inches apart; potatoes cut so as to leave two or three eyes in a piece and planted nine inches apart in the drills. The first three rows had unleached ashes put upon them at the rate of five or six quarts to the row. On the second three rows I put about the same quantity of air-slaked lime. The next three rows were salted, four quarts to a row. On the next three rows I put charcoal dust, six quarts to a row, and the balance of the piece was all ashed as the first three rows. Alongside this five rod square piece I planted in the same way, without ashes or any other application. When the potatoes were up six inches, I covered the first three rows with the scrapings of the barn-yard (all rotten manure) to the depth of about one inch; they were all treated alike in other respects. The result was, that the first three rows yielded four and a half bushels of sound potatoes; all the others, without material variation, yielded three bushels to each three rows; or about two hundred bushels to the acre for those not top-dressed, and three hundred bushels for the top-dressed rows—a gain of fifty per cent. to the latter. The potatoes were dug in the last week of October. Many *entirely rotten* ones were found—none *partially* decayed—no difference could be seen between those ashed and those not ashed. Not an unsound one in the lot at this date, (December 1st.)

I learn from the above that it will pay to top-dress potatoes—not much else.

I find that early planted potatoes in this county rotted as much as late planted ones; that potatoes shaded do not rot as much with some of our farmers as those not shaded; that Carter potatoes do not rot more than other potatoes, as I think I have the best crop in the county; that Mercer potatoes, early and late, were almost a total loss; and that even the Merinos did not escape the rot here this season.

BY JAMES B. SALLS, OF WEST POTSDAM, N. Y.

ABOUT the first of May I plowed a piece of green-sward, and on the 12th planted it with potatoes. On four rows I put in each hill a small handful of plaster; on four rows adjoining, and of the same length, I used no plaster. The difference during the season of growth was plain in favor of the plastered rows, and when dug they yielded six bushels; the rows not plastered, two and a half bushels. On the remainder of the piece I applied plaster to the hill at hoeing, and although an improvement, the result was not as favorable as when covered with the potatoes at the time of planting.

RURAL HOMES.

A SUBURBAN COTTAGE

In our January number we noticed a new book, entitled "Rural Homes," by GERVASE WHEELER, promising to give some extracts from the work in a future number. We are well pleased that works on rural architecture are multiplying, as this fact shows a demand for reading of this character. In every part of the country over which we have occasion to travel, we observe neat cottages, pretty "rural homes," springing up where but a few years ago nothing attractive in the form of a house could be seen. These may not all be designed in the most correct taste—some may exhibit redundancy of ornament, showing the want of such a work as Mr. WHEELER'S,—but still they are generally pretty and tasteful. These cottage buildings add much to the beauty of the landscape. Without further remark we give the promised quotation, selecting one of the cheapest and most convenient of the cottage plans:

"A cottage home suited to the neighborhood of some small country town, and indicative of refinement and taste on the part of its occupants, may be made a very pleasing feature in the landscape.

The illustration given here represents such a building, and I will proceed to describe it in detail, premising that its cost being but fourteen hundred dollars, it would be found within the means of most persons desiring such a house.

"The character of the exterior is architectural, partaking something of the Rural Italian. Its low walls, overshadowing roof, wide veranda, and projecting ombra in its southern front, give it an

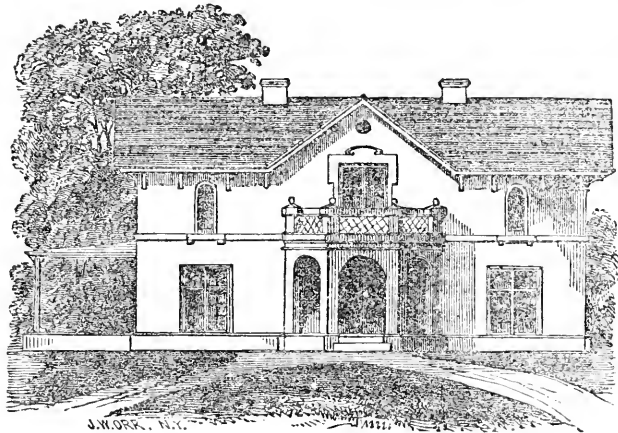

ELEVATION.—SUBURBAN COTTAGE.

appearance of symmetry and refinement that adapts it to the occupancy of a family of elegance and taste. The material of which it may be constructed may be stone, brick, or wood. If of stone, no change may be made in its form or the nature of its details, unless perhaps making them heavier, and their marked features still more bold. If of brick, I would merely add a projecting face, one brick wide and projecting two inches round all of the windows, and a band running horizontally below the brackets or cantilevers of the roof about a foot deep, upon which they may rest. If of wood, the covering should be clap-boarding or smooth ceiling, not battens and perpendicular planking, as the leading characteristics of the composition are horizontal lines, and would be contradicted by any other direction in the lines of the covering. The roof, of sufficiently steep a slope to carry off all water or snow, should be shingled, and the gable over the center of the southern front be made water-tight with metal strips in the valley formed by its intersection with the slope of the main roof. The chimnies, formed of brick, rise in simple form from the ridge, and as they have no portion of the roof or building higher than themselves, need not extend above the ridge more than sufficient to ensure good proportion of height to width.

"Before proceeding further with the exterior of the building, I will describe the plan.

"A peculiarity in this design is in the projecting half-octagon porch or ombra, which, from its position, serves the double purpose of a delightful and cool retreat, and that of

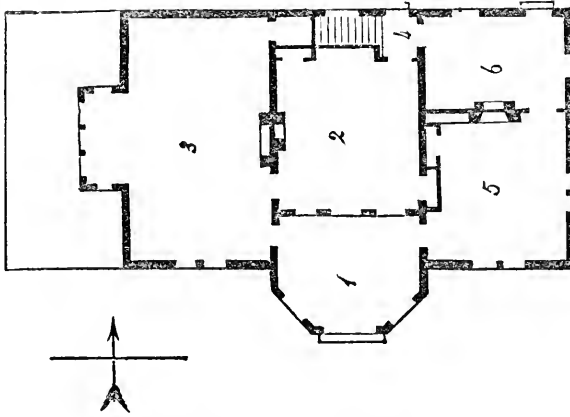

GROUND PLAN.—SUBURBAN COTTAGE.

an entrance-hall—it is marked on the plan, No. 1. In the winter, its sides might be filled with windows, and the opening in front with a glass door, thus making an enclosed vestibule or porch, and rendering the dining-room a very warm and comfortable apartment. From this porch are doors into the dining-room, No. 2; the parlor or library, No. 3; and the kitchen, No. 5; and according as a visitor's business in calling was to such and such a portion of the house, a door might be opened, thus

saving the internal room necessary for a hall, and yet gaining all the advantages of such a portion of the building. The dining-room is a good-sized pleasant room, fifteen feet by seventeen, with French windows opening upon the ombra or porch at one end, and a recess for sideboard underneath the stairs at the other. Attached to this room are the necessary adjuncts of china, glass, and store closets, one by the sideboard, and the other in the side of the room opposite to the stove or fireplace. Back of the dining-room is a small vestibule, five feet square, enclosed so as to shut off the staircase, and being the passage way from the pantry, scullery, and kitchen, to the dining-room. This entry is marked in the plan, No. 4, and is provided with an outer door. The economy in space attained by the arrangement of this portion of the plan must be evident at a glance, and the domestic comfort and convenience ensured, seem to me to render it very desirable. No. 3 is a large, well-proportioned apartment, twenty-five by fifteen, exclusive of a large projecting window in the side of the room. This would serve as a parlor, drawing-room, or country library, as the taste of the occupants lead them to determine. The projecting window opens upon a large veranda extending along the side of the room, and from one side of this bay-window a portion of the veranda might, if thought pleasant, be enclosed, forming either a conservatory or a small summer study, attainable at very little additional cost. As this house might in many places be thought adapted for the dwelling of the clergyman of some small society, I would suggest that the room I have just described would very agreeably afford ample space for purposes of clerical use, and the small study thus attached (entered by a door from the side of the bay-window) might be provided with a flue in one of its sides, so as to be warmed by a stove in winter. Few houses of far greater pretension and expense have rooms so spacious and well-proportioned as those in this little cottage, and hence its desirableness for erection. No. 5 is a kitchen, back of which is a large scullery and wash-room, No. 6. Underneath the building, a dry and well lighted cellar (lighted from the one end and the rear side) might contain a store and flour-room, a larder, etc., with a flight of stairs leading thereto. Back of this building, I would propose an enclosed yard, containing wood-shed, and such offices as are better out of doors, and as the pleasant, occupied rooms are all on the other side of the house, the yard so enclosed might extend along its entire rear length, and being conveniently opened into by means of the enclosed vestibule at the foot of the stairs, would be easy of access from the living rooms. This enclosed yard would keep

everything neat and orderly in appearance round the building, and give it a refined character in keeping with its more exposed exterior.

"The height of the rooms on this floor is ten feet in the clear, the walls to be prepared for paper, and the inside finish of doors and windows of the simplest, plainest description.

"The sleeping accommodation in the floor above is adequate to the comfortable use of a small family, and is arranged as follows:

"No. 1 is a hall, well-lighted and roomy, containing the staircase from below, and from which open the doors into the several chambers.

"No. 2 is a large room over the dining-room and extending clear to a line with the front of the house, the recessed portion below being floored over. From this room a window opens upon a large balcony, No. 3, over the truncated projection of the porch below.

The room is provided with a large closet for clothes, and a flue for a stove or fireplace.

"No. 4 is a large linen-closet, well-lighted, and formed by the small entry from the upper hall leading to rooms Nos. 5 and 6.

"No. 5 is a small chamber or dressing-room, in which might be a bathing apparatus, and serving either as a separate single room, a child's sleeping-room, or a dressing-room connected with the larger chamber, No. 6, which is over the library or parlor below, and is provided with a spacious clothes-closet and a flue for a stove or fire-place.

"No. 7 is over the kitchen, and has also a large closet and a fire-place, and No. 8 is a servants' sleeping-room. This room is shut off from the other chambers by an entry similar to that on the other side of the hall, and is sufficiently large for the purpose and is well-lighted and ventilated.

"No. 9 is a large store-room, well-lighted and airy — completing the accommodation provided on this floor, and the compactness and convenience of the plan must, I think, favorably recommend itself.

"The rooms on this floor extend partly into the roof. The walls are seven feet high to the under side of the plate, and the ceiling follows the slope of the roof sufficiently far to allow the rooms to be ten feet in the clear. The roof is so framed as to admit this, and by such an arrangement greater internal height and airiness are obtained, with more modest lowliness of the exterior. The sloping sides of the ceiling should be firmed down so as to leave a space of dead air (the most perfect non-conductor) between the lathing and the covering of the roof; by this means the rooms will be always cool and the additional height gained be very valuable. The room over the dining-room having a gable over its ceiling would be a higher and more symmetrical apartment than the others, and hence might be reserved as the guest-chamber, its large balcony making it a very pleasant sitting place for ladies with their books or needle-work."

The author further remarks that the furniture and finish of such a house as this should be very simple. The tables and chairs of oak, maple, or birch; in the summer the floor should be covered with India matting, and in winter with carpeting of the pattern called mosaic, and the colors orange or crimson, and brown or black, except for the parlor, which should be a little more lively. The paper of oak pattern, or some other one-toned character.

"Around the bay or projecting window, a low chintz-covered seat, excepting where the windows open to the veranda floor, or the door (if there be one) leads into the study

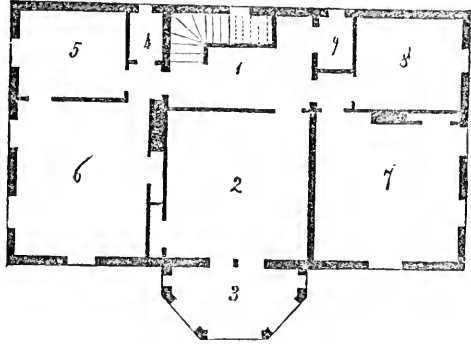

CHAMBER PLAN.—SUBURBAN COTTAGE.

or conservatory, and as the space would be large, its center might prettily be occupied by a light and elegant work-table, or by a rustic flower-stand or jardiniere. The accompanying engraving shows a pretty rustic flower-stand just suited to such a situation, and as it is inexpensive and can easily be procured, I have given its representation. It is made of bark finished neatly and varnished.

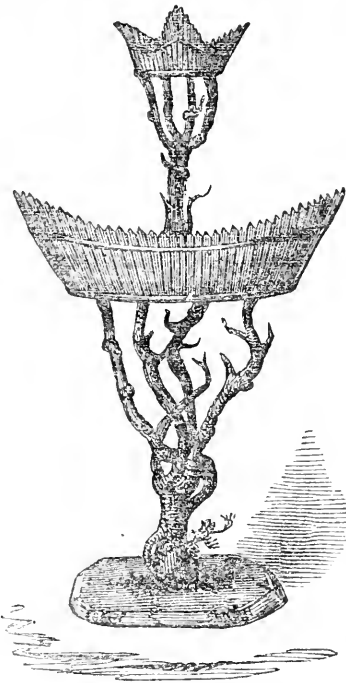

RUSTIC FLOWER-STAND.

“The color of such a building should be light—whatever the general aspect and tone of coloring of the objects around, that let it be. If surrounded by trees, with a leafy background, its coloring should be warm and approach the cream; if standing more alone, with rocky foreground and bold crags near enough to be seen in outline and color, quench the warmth somewhat by deepening the cream to a light cool brown; if other buildings are near, and the background be circumscribed, give the building relief and its features distinctness by using more than one color thereon—covering the main block with a warm light tint and deepening the prominent portions, as window frames, cornices, brackets, doors, veranda posts, and ombra or porch.

“Sanding paint, or mixing sand therewith, besides assisting in its preservation, takes away from the oily glare and glisten of ordinary pigments, and by lessening the refracting power, gives to the surface of the building a softer and more pleasant tone of coloring. But I do not recommend this process in all cases, believing in no universal rule that admits not of exception; frequently where the detail is minute, the roughened appearance imparted by the use of sand gives a clumsy aspect to the part, and in all cases where sharpness of outline is sought to be obtained by any particular decoration of the construction, the use of sand would be perfectly inadmissible. By using the last coat of oil color thick and smooth, without boiled oil, or any fatty, or resinous substance, a flat, unshining surface may be obtained, more durable than a brighter, reflecting coat would be, and more pleasing in effect.”

PLAN OF A FARM-HOUSE.—Observing that you devote a portion of your paper to this subject, I send you a plan of a house which will, I think, lessen the wants of a large number of the farming community.

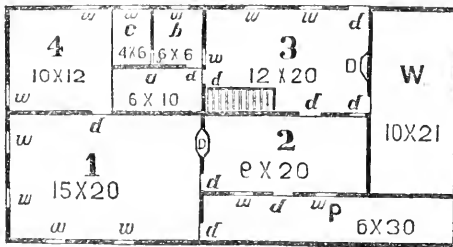

We are, at this age of improvement, rather selfish in regard to our pecuniary affairs, and it is a desire and an interest, and at times necessary, in erecting our farm buildings, to do it as cheap as possible. If you think the accompanying plan will be of use to any of your subscribers, it is at your disposal.

Description.—1, Parlor. 2, Dining room. 3, Kitchen. 4, Bed-room. W.

Wood-house. P, Porch. a, Clothes-press. b, Pantry. c, Meal-room. w, Windows, d, Doors. D, D, Chimnies. S. A. T.—Gorham, N. Y.

BUTTER MAKING.

It is a very general opinion among dairywomen that more butter is obtained from a given quantity of milk when set in pans partly filled than when full. If this is true, it is well worth knowing; if not, a great deal of useless labor is expended. As the question has been often asked me, and I could give no answer, I determined to make the trial. As the result, so far as it proves anything, is of general interest, I send it for insertion in your paper. Such an experiment is valueless unless conducted with extreme care, and your readers might well doubt its accuracy unless shown that proper pains were taken. I will therefore give the particulars.

On the morning of the 20th November, the milk was strained all together into a tub. It was then dipped out into a pail holding five and a half quarts, which was filled carefully to the brim. Pains were taken that if any rich milk or cream had risen to the top, it should not be skimmed off, as it were, by dipping. The first pail full was turned into one pan, and the second into two, and so on alternately. There were eleven of the former and twenty-two of the latter. They were placed on the shelves of the milk-room alternately, lest the difference of position should affect the result. The milk stood till it thickened, which was about four days. The full pans thickened sooner than the other. As there was not quite enough cream of each kind for a suitable churning, and that not a particle be lost, considerable milk was taken off in skimming. The cream from the half filled pans was a *very little* warmer when put into the churn than the other. It could hardly be perceived in the cream, but it came sooner and was a *trifle* softer to work over. When weighed there was 6 lb. 7 oz. from the full pans, and 6 lbs. 2½ oz. from the pans half filled. This was an unexpected result, but I could conceive of no vitiating cause unless possibly the slight difference of temperature in the cream might affect it. The pans were of the usual size—the bottoms being about 11½ inches in diameter. The milk stood 2½ inches deep in the full pans. A pound of butter was obtained from 9½ quarts of milk.

To verify this experiment, or to detect mistakes, if any, I repeated it. On the mornings of the 29th and 30th of November, 210 qts. of milk were set with the same precautions as before—six quarts in the full pans and three in the others. This stood nearly a week before skimming. No difference of temperature could be perceived in the cream when put into the churn. If there was any difference in the butter, that from the full pans was a trifle softer than the other—the reverse of the former experiment. From the full pans there was obtained 12 lbs. 10 oz. of butter, and from the others 12 lbs. and nearly 1 oz. The difference in this case was about 4½ per cent., the same as in the former trial. The milk stood in the full pans 2.7 inches deep. A pound of butter was obtained from 8½ qts. It is all of three times as much work to skim the half filled pans as the others. The question then arose whether still larger dishes were not better. Another trial was made by setting 208 qts., with the same precautions as before, one-half in pans holding six quarts, and the other half in those holding twelve quarts. From the small pans was obtained 10 lbs. 15 oz., and from the larger ones 11 lbs. 3½ oz. The difference in this case, of 4½ oz., was about 2½ per cent. in favor of the large pans.

The reason that the full pans each time gave the most butter, I cannot give; but I think the result is owing to unequal evaporation. The amount of cream and skim-milk is much less than the new milk. The milk from one full pan and two half pans was measured, and that from the full pan was half a pint the most, or one-twenty-fourth of the whole. This is four and one-sixth per cent., about the same difference as in the butter. If this is not the reason, I can conceive of no other. L. N.—*Sherburne, N. Y.*

THE VALUE OF BARN-YARD MANURE.—It is now pretty generally admitted that the chief analytical criterion of the relative value of different kinds of manure is the amount of ammonia they contain. From several analyses by MESSRS. LAWES & GILBERT, it appears that a "ton of rich box manure," or manure produced by fattening animals with rich food in boxes, contained $14\frac{1}{2}$ cwt. of water and $5\frac{1}{2}$ cwt. dry substance; the latter containing a large quantity of mineral matter, and nitrogen equal to 20 lbs. ammonia: while manure made by eating, treading, and wetting straw, and rotted to the same degree, contained the same amount of water with less than one-half the important minerals, and nitrogen equal to only 5 lbs. ammonia. Most farmers are apt to imagine that "a ton of manure is a ton of manure," irrespective of its origin; and think if they are about the same to the eye they will be the same to the plant: but it is not so. A ton of manure made by sheep eating clover hay, would be worth three tons of that made by eating straw; and a ton from the consumption of peas or oil-cake would be worth as much as eight tons of the strawed manure. The value of the manure depending, other things being equal, on the amount of nitrogen in the food consumed, and not so much as is sometimes supposed on the kind of animal producing it. JOSEPH HARRIS.—*Rochester, N. Y.*

HESS BARLEY.—Enclosed I send you a head of barley, the only one I could find in my barn, the crop having been threshed out early in the fall. I think it is hardly a fair specimen, but it will serve to show you, if you have not seen the variety before, the difference between this and the common two rowed barley, which consists in the kernels being placed nearer together—the same number occupying between one-half and two-thirds the length of head of the other variety. The straw is also much shorter and stouter, and will stand well where the other is entirely laid. It is being disseminated rapidly in this vicinity, and is estimated by different farmers to yield from ten to 20 per cent. more than the other, especially on rich land. It originated in the adjoining town of Fenner, on the farm of DAVID HESS, Esq., about six years ago. Three heads were discovered proceeding from one root among the common two rowed barley, which was planted and multiplied by him until he was able to sow two acres, I think, when he began to disseminate it among his neighbors. If you wish for a quantity of seed for distribution, I will send it to you. Perhaps a more full and accurate account of it may be obtained of Mr. HESS. J. B. MORSE.—*Cazenovia, Madison Co., N. Y.*

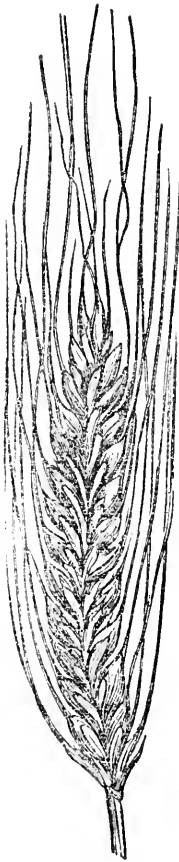

HESS BARLEY.

GROWING FLAX WITH BARLEY.—I will inform you of a practice which prevails here, of sowing flax with barley; it may be new to some of your readers. After the ground is plowed, two bushels of barley are sown to the acre and harrowed in; one peck of flax seed is then sown to the acre and cross harrowed. It is harvested and threshed together, and is easily separated when cleaning, by the flax seed passing into the screen-box. The barley seems to do quite as well as if no flax were sown. The past season, I had thirty bushels of clean barley and three bushels of flax seed to the acre. The land had been in corn the previous season, and was manured with stable dung and leached ashes. H. M.—*Lawrence county, Pa.*

Sheep Husbandry.

VERMONT AND THE WEST.

BY S. BIRD ROCKWELL, OF CORNWALL, VERMONT.

WHAT relation does Vermont sustain to the great west, on the important and deeply interesting subject of wool-growing; and what breed, or breeds of sheep, are best adapted to its wants and prosperity.

To the first of these inquiries we answer: Its relation is that of a vast reservoir to a distant jet or fountain; it is that of a mine to the production and circulation of the precious metals; or that of the vast and full ocean to the showers that fall in timely periods, for the refreshing of the parched and suffering earth. Vermont can, without boasting, challenge the world to produce a race of sheep surpassing hers in true and real merit. That class of sheep which will produce the largest yield of good wool and mutton from a given amount of feed, is undoubtedly the best. Vermont, in her celebrated Merino flocks, has such a class.*

It is an error to suppose that the Merino affords an inferior quality of meat. The greatest epicures in Brighton pronounce such an opinion unfounded in fact, and unsupported by reason; it is destitute of any basis in truth, and may be regarded as the dream of an Englishman, or a relic of the dark ages. For weight of fleece they are unrivalled. In 1840, Vermont produced more wool than Ohio, and yet had nearly one million less sheep. The saving to Vermont, in way of keeping, was nearly one and a half millions of dollars, as the estimated expense is \$1.50 per head per annum.

Western farmers are now eagerly inquiring for some branch of agricultural industry that will give them better returns for labor and capital invested. Wool growing is that branch, and, in proportion as they obtain good sheep, so will they engage in this noble and lucrative employment. But from whence can they be obtained? Not from the north, not from the south, nor from the west,—but from the east. The breeders of choice sheep in Vermont, aided by a few good flocks now springing into note in the Empire State, must furnish this great field. Vermont has much of her own State to supply with better sheep. It is a mistaken notion, so generally obtained west, that all the sheep in Vermont are intrinsically valuable. The majority of the flocks in the State are indifferent in their character, and possess no peculiar merit. There is doubtless more thorough bred flocks in Addison and Rutland counties, than in all the rest of the State. The reputation of these counties is well earned and deserving. Vast outlays of capital and labor, during the last twenty years, is the corner-stone of this reputation. Money and time have been poured out like water, and no efforts spared to secure the best sheep that the world could boast of. We can but hope that this reputation will be guarded as a precious treasure. This eminent power and skill of producing stock sheep, is the cause of everything great in their position and history. It is the rude foundation of their fair Corinthian pile; and they are as much indebted to this as Egypt to her Nile, Athens to her schools, or Rome to her policy and arms. As a box of precious jewels let this reputation be preserved, and never suffered to tarnish by neglect or abuse. Shall it be so? We have had our fears awakened that it might prove otherwise. Under this reputation, very many indifferent sheep have been glossed over with oil and lamp-black, and taken West and sold for high prices. This may be news to some; others have

* "The Merino wether at four years old comes to perfection and makes a splendid mutton, and will invariably command a good price. I am sure that an acre of land will give as many pounds of Merino mutton as from any other breed, and I am sure of decidedly better quality. In proof of this last declaration I can produce the most satisfactory testimonials."—*Theodore N. Davison, Esq., of Virginia.*

been made acquainted with the fact to their sorrow. Some villains have attained such a degree of skill in manufacturing these pseudo Merinos, that it is well calculated to deceive good judges. At first it was done slyly; now it is perpetrated with fiendish boldness. It has gone too long unrebuked already. Such conduct calls for the execrations of all good men. It is not only unjust, but impolitic; and must assuredly re-act with retributive justice upon us. In the name of Vermont—in the name of justice—in the name of everything good and true—we disclaim all fellowship with such deeds of darkness, and would hold up to the scorn of their fellow men all who are guilty of such *meanness*.

We have been advised of various deceptions practiced by the sheep-dealers of Vermont, by which they have been enabled to palm off, at high prices, very inferior sheep; which farmers are induced to buy for the purpose of *improving* their flocks. It is unfortunate that so many unprincipled men are always ready to take advantage of every attempt of the farmer at improvement, to obtain his money by fraud. If you are not a good judge, ask the advice of some competent friend; or buy only of men of known integrity.

BREEDS OF SHEEP, AND THEIR COMPARATIVE VALUE.

FEW subjects are less understood by the generality of farmers than the proper management of sheep and the breeds best adapted for certain purposes. No species of husbandry will pay so well at this time, in most parts of the country, as a proper and careful attention to the rearing and fattening of this valuable animal; and we are glad to perceive an awakening interest exhibited in the subject.

For the manufacture of fine cloth, wool is valued according to its felting properties, and is possessed by some breeds in a higher degree than others. The serrated edge of the wool is supposed to be the chief cause of this difference, and it will therefore be interesting to give the appearance of a single fibre when viewed as an opaque object under a microscope of 300 linear power.



FIBRE OF MERINO WOOL.

under a microscope of 300 linear power. The Merino wool was found to have 2400 serrations on an inch, and had the appearance of teeth on a fine set saw, projecting in one direction—from the root upwards.



FIBRE OF SOUTH DOWN WOOL.

The South Down wool is evidently a coarser article, with fewer serrations, and not so acute as the Merino. It is a useful article, but is now but little used in the manufacture of *fine* cloth, on account of its inferior felting properties.



FIBRE OF LEICESTER WOOL.

The far-famed Leicester, or long wool, is never used for fine cloth; but is very useful for other purposes, on account of its strength and length. It is much thicker, the serrations are not so numerous and are less acute than either of the former. Its diameter is one five-hundredth of an inch in length, and there are but 1860 serrations in an inch.

Spain, from an early period, has been justly celebrated for the beauty and fineness of its cloth. From the eighth to the sixteenth century she was about the only manufacturer in Europe. In the thirteenth century there were in Seville 16,000 looms. After the expulsion of the Saracens the woollen manufacture languished. Ferdinand the Fifth banished 100,000 industrious artisans and weavers from the country, because they were Moors, and was honored with the title of Catholic in consequence. His successor followed his example, and expelled between 700,000 and 800,000 Mahomedans in four years. The natural consequence of this was the destruction of the manufacturing interest. The government discovered their mistake too late to avert the injury; yet, knowing the value of their flocks, the farmers sedulously cultivated them, and the sover-

Spain, from an early period, has been justly celebrated for the beauty and fineness of its cloth. From the eighth to the sixteenth century she was about the only manufacturer in Europe. In the thirteenth century there were in Seville 16,000 looms. After the expulsion of the Saracens the woollen manufacture languished. Ferdinand the Fifth banished 100,000 industrious artisans and weavers from the country, because they were Moors, and was honored with the title of Catholic in consequence. His successor followed his example, and expelled between 700,000 and 800,000 Mahomedans in four years. The natural consequence of this was the destruction of the manufacturing interest. The government discovered their mistake too late to avert the injury; yet, knowing the value of their flocks, the farmers sedulously cultivated them, and the sover-

eigns, except in a few instances, strictly prohibited their exportation. In 1786, the king of France imported 400 ewes and bucks selected from the choicest breeds in Spain, and placed them on his farm at Rambouillet; from these the celebrated breed bearing this name derives its origin. Chancellor LIVINGSTON imported, in 1802, two very choice ewes and rams of this breed to his farm on the Hudson. Col. HUMPHREYS, our minister at Spain, also imported a considerable number of superior Merinos. But the largest importation was in 1809. Mr. JARVIS, of Vermont, when U. S. consul at Spain, shipped to this country, as he states, "200 Esecurials, afterwards, 1400 Paulars, 1700 Aqueirres, 100 Nigrettis, and about 200 Montareos. 2700 Montareos were sent out by a Spaniard and a Portuguese, and about 300 Guadaloupes by others; also, 200 to 300 Paulars, by Gen. DOWNIE, to Boston. Of the Montareo flock shipped by others, about 2500 came to Boston, Providence, New York, and other ports. All were imported in the latter part of 1809, '10, and '11, and were the only Leonese Transhumantes, if we include HUMPHREYS' and LIVINGSTON'S, (which I have no doubt were of the same stock,) that were ever shipped to the United States."

The excellence of the Merino consists in the unexampled fineness and felting property of the wool, and the amount given by each sheep. The closeness of the wool and luxurious yolk furnish these sheep with an impervious coat of mail, which resists rain, snow, or any impurities that would injure the wool; enabling the animal to stand, without much harm, great extremes of temperature; while its voracious appetite makes it apparently satisfied with the coarsest food, and it will stand an occasional scarcity better than any other breed.

Some object to the Merinos for their want of symmetry, their paucity of fat and lambs, and their liability to cutaneous diseases. The latter objection we think unfounded; and when it occurs, is doubtless owing to improper treatment rather than anything peculiar in the functions of the skin. None will question the great value of the Merino in a district where sheep are kept principally for their wool; as they will, with proper attention, yield a larger quantity, which sells for a higher price than any other.

But as the population of the country increases, and a greater amount of food is consumed, mutton will be in request and high prices paid for a superior quality. In the neighborhood of large cities the demand for good mutton has induced many farmers to raise sheep more for the mutton and tallow than the wool; and they find it exceedingly profitable. With such, the South Down, or middle wool, is a deserved favorite. The fine flavor of the mutton is well known, selling in the London market for two cents per pound more than any other kind. The wool is of a medium quality, rather short and thick, selling for about twelve cents per pound less than Merino. The average of a good flock would be about four pounds of washed wool per sheep. They mature much earlier than the Merino. We have known a flock of 125 South Down wethers, fed with American oil-cake, clover hay, and ruta бага, average 168 lbs. live weight, and 96 lbs. carcass when slaughtered, at from ten to twelve months old. They were never shorn. One hundred ewes, unless of very pure blood, will bring 150 lambs. The ewes are usually sold off when five years old, as they then begin to lose their teeth. A buck, if grained, will serve eighty ewes in a season. The accompanying engraving represents two fine specimens of this breed in the possession of LEWIS G. MORRIS, exhibited at the New York State Agricultural Fair in 1851, to which the Society's premium was awarded as best over two years old. They are very hardy, standing cold, wet weather, and heavy soil, much better than the long woolled sheep. Two pounds per head is a good average weekly increase, when fattening for the butcher; though we have known 100 average three and a half pounds increase per week, in summer, when running in good clover. In the vicinity of cities we believe this breed will pay better than any other.

The Leicester, or long woolled sheep, has its admirers, who prefer it to any other breed. Mr. BAKEWELL, of Dishley, England, by breeding in-and-in, and careful attention to the

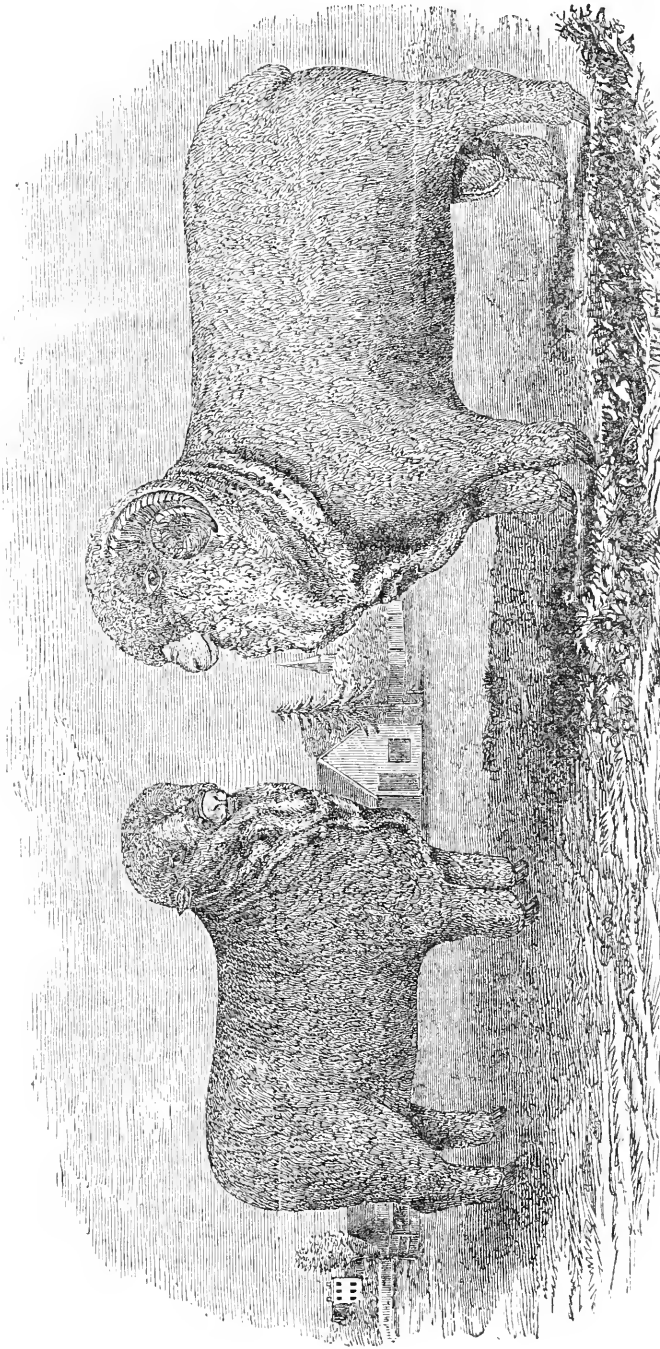

MARQUESE DE ROUGE,
 ONE YEAR OLD, SHEARED 10 LBS. 10 OZ.

LOUIS PHILLIPPE,
 ONE YEAR OLD, SHEARED 14 LBS. 8 OZ.

FULL BLOOD MERINO SHEEP.

IMPORTED FROM FRANCE BY J. A. TANTOR, ESQ., OF HARTFORD, CONN., AND NOW OWNED BY JOHN D. PATTERSON, OF WESTFIELD, CHAUTAQUE CO., N. Y.

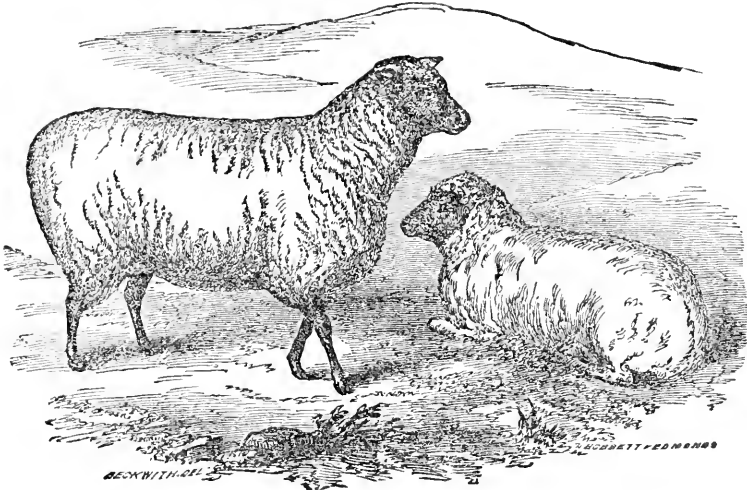

SOUTH DOWN SHEEP.

defects and superior points of the ewes and rams he bred from, raised this breed to great perfection; in fact, may be said to have originated it. For rich lowland pastures, the Leicester has no equal. It matures earlier, fats quicker, and yields more wool for the same amount of food, than any other breed. It is not such a good breeder, is a poor suckler, and the mutton is coarser than the South Down. It will not stand wet, heavy land, and an occasional scarcity of food, so well as the short wools. There are a considerable number of this breed, of more or less purity, scattered throughout the country. We give an excellent representation of the best long woolled buck and ewe over two years old exhibited at the New York State Fair at Rochester in 1851, owned by J. McDONALD and WM. RATHBONE.



LEICESTER SHEEP.

Horticultural Department.

CONDUCTED BY P. BARRY.

THE FUCHSIA.

THE FUCHSIA is a green-house shrub of small size, seldom exceeding five to six feet in height, and many species not over two or three feet. There is nothing particularly remarkable about the wood or foliage, the chief beauty and character being centered in the flowers. These are of a tubular shape, and have a very graceful pendant habit, combined with great diversity and strong contrasts of the most brilliant and delicate colors. Nearly, if not all, the species yet introduced, are from Mexico and South America. It belongs, in common with the *Clarkias*, *Onocheas*, *Godetias*, *Zauchsneria*, and several other ornamental genera, to the natural order *Onogroceae*, (Onograds of Lindley's Veg. Kingdom.) and received its generic name in honor of a German botanist, LEONARD FUCUS. It has been cultivated in Europe for thirty years or more, but until ten or twelve years ago did not receive general attention or become really a popular plant. Recently it has become one of the leading objects of pot-culture, and in regard to popularity ranks with the *Rose*, the *Dahlia*, the *Verbena*, &c. It hybridizes with the greatest ease and success; and therefore varieties almost without number, and far surpassing in beauty the original type, have been produced. In Europe, not only in commercial plant establishments, but in private gardens we find whole houses filled with it. Some of the most interesting sights of pot plants we met in our European travels last summer were collections of Fuchsias, in some cases forty or fifty varieties together, all loaded with their graceful, pendant, brilliant blossoms. The prevailing system of flower-gardening, which is the bedding out of green-house summer-flowering plants in masses, has given a great impulse to Fuchsia culture; for in England it is well adapted to this mode of garden embellishment. Like most other plants that hybridize freely, a multitude of varieties are produced that are deficient in character, requiring the critical eye of the experienced grower to detect the points of distinction. Hence, now it has become a matter of no little difficulty to select an assortment embracing the most beautiful and yet really distinct varieties. It is a very great misfortune, both for the professional and amateur cultivator, that some well defined and stringent regulations do not exist for the admission or exclusion of new varieties. The evil begins to be no less seriously felt in the ornamental than in the useful branches of culture. We know of no source to which we can look for a remedy but to nurserymen and florists. If they will unanimously set their faces against mere novelties in name, without any novel or distinct characters, then people may purchase with some degree of safety; but as long as the present foolish rivalry as to who shall get all novelties *first*, without regard to real merits, so long will floriculture be embarrassed, and purchasers and growers be disappointed. Every man who sends an order for a dozen or half a dozen Dahlias, Roses, Fuchsias, Chrysanthemums, or any other genus, should say, "*Send me none but what are really distinct—obviously distinct. I want not merely slight botanical distinctions, but such as will enable me to have striking variations and contrasts in growth, foliage, and habit of plant, or in the size, form, and coloring of the flowers.*" If purchasers will express themselves in this way, and say that they prefer half a dozen good, well marked, and really beautiful varieties, to a dozen or twenty that possess but a striking *uniformity*, they will be getting on the right track; and nurserymen and florists, who are generally but erroneously supposed to be partial to large and long lists of names, will, we know, acknowledge the favor gratefully. Both professional and amateur growers should work together in this

matter for the common good; if they do, we venture to predict that no man will have the assurance to ask \$5 or \$10 for a *new* plant that does not possess a single characteristic to distinguish it from others that can be bought for \$5 per dozen.

To return to our subject, the Fuchsia, we will state the points that claim attention in judging of the merits of a variety. As we have already noted, the chief attraction lies in the flowers, and it is to them we must look, in the main, for the merits of the variety. The Fuchsia flower consists, like most other flowers, of a calyx, corolla, stamens, and pistil. These parts in the aggregate make up the flower; and it is their relative size, form, and color, that give those characteristics that constitute the excellencies and beauties of the variety. The calyx, unlike the calyx in most other well known flowers, is colored, and is one of the most striking parts of the flower: a part of it, at the base, is a tube; at the mouth it is divided into four parts called sepals, and these are more or less reflexed, (turned backwards,) as shown in some of the annexed figures, displaying the corolla, which is situated in the throat of the calyx. The more this calyx is reflexed—that is, the more fully the corolla is displayed, the better is the flower, other things being equal. The calyx and corolla are seldom of the same color; and the qualities of the flower depend not only on the depth, richness, and delicacy of the colors, but on the beauty or novelty of the contrast between the calyx and corolla. Then the stamens and pistil, by their length, projecting far beyond the other parts, and by their coloring also, especially of the anthers and stigma, give character to the flower and constitute part of its beauty. Then the flower stalk, or petiole, must be considered: the longer it is, the more pendulous the flowers are, and the more graceful the habit; the stronger it is, the better the flowers stand out from the foliage. The requisites of a plant are—distinct and fine foliage; free, robust growth; and profuseness of bloom.

These are the main points to look to in selecting a Fuchsia or a collection. People are too apt to be struck with one feature, and overlook the rest. For instance, if they find a plant with a flower on it, and it happens to please them, they seldom stop to inquire into other important qualities that should never be overlooked. Now we shall describe briefly a few select varieties selected from fifty which we have under cultivation. The first on the list is the

Pearl of England.—This, to our fancy, is the finest yet introduced; certainly the finest of all those hybrids with light colored tubes. The annexed figure shows this in the natural size. The calyx is of a pale flesh color, or nearly white, well reflexed, showing a fine, full, bright scarlet corolla. It grows freely and blooms most profusely. New.

Eliz Mielliez.—Nearly as good as the preceding, and somewhat similar. The calyx is of a rosy bluish towards the base, nearly white at the mouth, well reflexed, showing a deep rosy pink corolla. Grows well and blooms freely.

Fair Rosamond.—A long, elegant flower, well named for its grace and delicacy. Calyx long, almost pure white, not much reflexed, but showing a fine, rich, scarlet corolla. Plant vigorous and blooms freely.

Snow Drop.—Flower rather short; calyx pure white; corolla light crimson. Plant

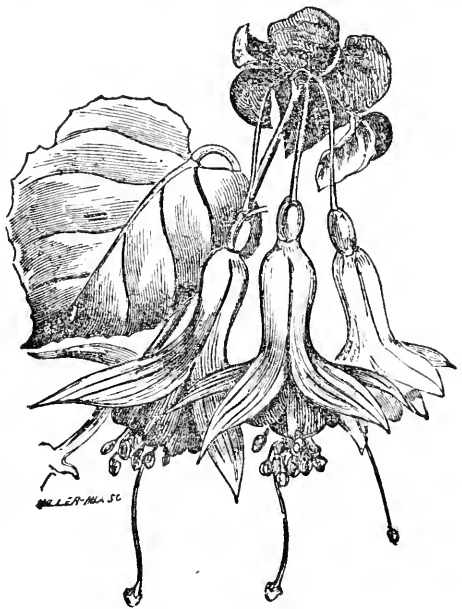

PEARL OF ENGLAND.

grows freely, but requires pinching back to keep it compact and well branched.

Magnificent.—A splendid large flower, rosy calyx pretty well reflexed, showing a large, rich, rosy salmon corolla.—Habit spreading and vigorous, and a free bloomer.

Nonpareil.—A large, showy flower; calyx rich deep crimson, well reflexed, showing a fine rich rosy purple corolla. Good habit.

Grand Master.—Very distinct. Calyx short, of a bright red. Corolla large and conspicuous, of a deep purple. Branches dark red, slender, and drooping. Blooms profusely.

President.—Very distinct. Calyx pale rose; sepals very narrow and well reflexed, showing an unusually large violet red corolla. Foliage distinct, large, dusty green, heart shaped, and sharply toothed.

Evoniensis.—Rather an old sort now, but good and distinct. Scarlet calyx well reflexed, contrasting finely with a rich, dark violet purple corolla.

Fulgens.—A distinct species, introduced a few years ago. It has tuberous roots, strong succulent shoots, and leaves almost as large as a man's hand. The flowers are produced in clusters. The calyx is two inches long, of a bright scarlet. The corolla, scarcely seen, is of a deep fiery scarlet. When this variety was introduced, it created quite a sensation among florists, and is yet one of the most admired. It is a strong, rapid grower, rather coarse, and attains the size of a large shrub.

Corymbiflora.—This is also a distinct species, from Peru. It is a rapid grower, and attains a large size. Foliage very large, of a pale green, soft and downy. Flowers in large clusters, very long—two inches or over—and of a bright crimson. A showy and an elegant plant, but somewhat coarse, and appearing to good advantage only when it has attained large size and full blooming condition. There are two new ones that promise well—hybrids between the two last named. One is called *Fulgens corymbiflora*; and the other, *Corymbiflora alba*.

Serratifolia.—This is also a species, or a sub-species, quite distinct in appearance—

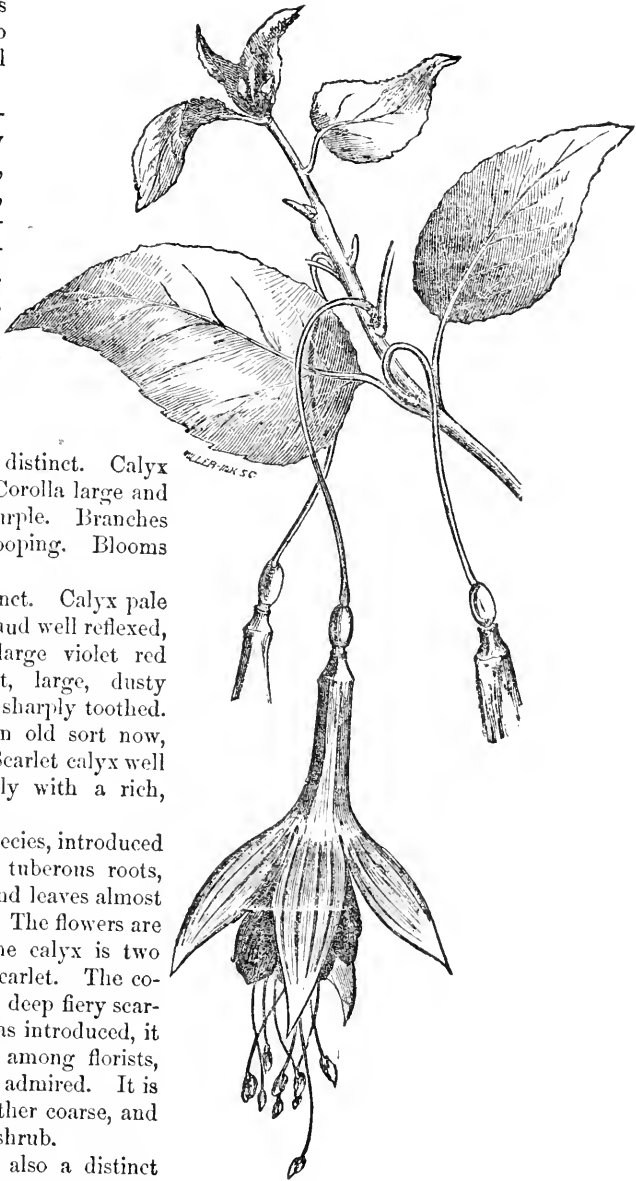

MAGNIFICENT.



SERRATIFOLIA.

newly introduced, from Peru. We have bloomed it the past autumn, and are delighted with it. It does not bloom like the others, in the summer, and we began to think badly of it; but in October the young plants of last spring commenced blooming, and continued through November and even December—a season when they were highly desirable. This late blooming of the young plants may be a useful trait. The habit of the plant is low, stout, bushy. The leaves are very dark, opposite in fours (verticillate) on the

branches, and the flowers are produced from their axils, one from each leaf. Flowers about one and a half inches long, with a graceful drooping habit. Calyx bright rose; points of sepals green; corolla scarlet; stamens prominent, bearing beautiful white anthers; making in all a fine assemblage of colors and contrasts. This looks like a plant that will stand the sun well; and if so, it will be a first rate bedding plant. For this purpose plants of one season's growth should be used, in order to ensure a good autumn bloom. The engraving on preceding page represents this flower of natural size. There is also a *Serratifolia alba* and *rubra*, but we have not bloomed either yet. *Serratifolia multiflora* is more dwarf and a more profuse bloomer than its type.

Globosa major.—An old favorite, and still holding its place well among all the new and fine sorts. It is of low, bushy habit, and blooms in immense profusion, like the old

Globosa, when even three or four inches high; and it blooms all summer. The flowers are almost globular, and before they open, hang like elegant crimson beads on the branches. The calyx is crimson and the corolla purple. It succeeds well in the garden in the summer, and is on the whole so fine a plant as yet to be indispensable.

Alboni.—This is a hybrid from *Globosa*. Flower short. Calyx pale rose, well reflexed. Corolla blush, edged with deep rose. Very pretty, and a most profuse bloomer.

Tom Thumb.—Another from *Globosa*.—Blooms when only two or three inches high. Flowers small, globular. Calyx cherry red. Corolla purple.

Spectabilis.—This is a *species*, found in the Andes by Mr. LOBB, (Veitch's collector,) and introduced into England in 1848. It is described as the "Queen of Fuchsias." The plant, like *Fulgens* and *Corymbiflora*, attains a large size; has large, rich, deep green foliage, and long, elegant, deep red flowers.

President Porcher.—Raised in 1850, by MIELLIEZ, and named after PORCHER, of Orleans, who is one of the best Fuchsia growers in France. A superb variety; large foliage, and very large, finely shaped, purplish crimson flowers. PORCHER says it knows no rival.



GLOBOSA.

Venusta is a *species* also, or a sub-species, of which a good deal was said; but it turns out to be similar and inferior to *Serratifolia*.

Syringæflora is another *species*, grown by M. VAN HOUTTE, of Ghent, from seeds sent him from Guatemala. In the space of one year it grew to five feet in height, well branched, and produced immense clusters of flowers after the style of a Lilac; hence its name. The beautiful engraving in the "Flore des Serres" is really tempting, but the reports of cultivators are not very favorable.

We must add, before leaving this part of the subject, that we might name a dozen more fine sorts; but our list is already long, and we have given such as we know to be really distinct and desirable. We intended to give some hints on the propagation and culture of the Fuchsia, but we have already extended this article beyond the allotted bounds, and must defer the remainder till next month.

DESCRIPTIONS OF NEW PEARS.

BY B. DESPORTEZ, OF ANGERS, FRANCE.

Bonne des Zees, (Fig. 1.)—*Fruit*—large, about four inches long and two inches and three quarters in diameter; pyriform, irregular. *Surface*—uneven, one side concave and the other convex. *Stalk*—very large, irregular, larger at the base, about two-thirds of an inch long, inserted on the surface. *Calyx*—small, set on the surface, segments open. *Skin*—thin. *Color*—gray, especially toward the eye and stem; greenish yellow in the middle. *Flesh*—white, very fine, melting, tender, buttery, juicy, and sugary. Ripens end of September and beginning of October.

This fine pear deserves, by its beauty and excellence, an extensive trial. It was put in the trade by Mr. DUPUY, and was originated from seed at Loches, France. The tree is a vigorous grower, naturally pyramidal in habit of growth, and a good bearer.

Beurre Derouineau, (Fig. 2.)—Some years ago, Mr. DEROUINEAU, of Angers, having sown some seeds from the *Glout Morceau*, obtained young trees, one of which came into bearing in 1840. Mr. DEROUINEAU presented the first fruits to the committee of horticulture, who gave to it the name of the originator.

This fruit is small, as will be seen by the annexed outline; obovate or obtuse turbinate, roundish toward the eye, very broad, narrowing one-third of its height towards the stem, where it terminates in a small basin, in which the stalk is inserted. *Stalk*—about one-third of an inch long, slender, and upright. *Eye*—large, broad, closed, set in a broad, deep, and somewhat folded cavity. *Color*—deep gray, spotted with russety gray dots everywhere, except around the basin of the eye. *Flesh*—white, fine, melting, buttery, juice abundant, sugary, and highly perfumed. It is one of the most delicious new pears obtained in a long time. We compare it, for its high flavor, to the American *Seckel*, which it also resembles in form; and hence we call it the *French Seckel*. It differs from it only in being darker colored and ripening later—about the last of Oct.

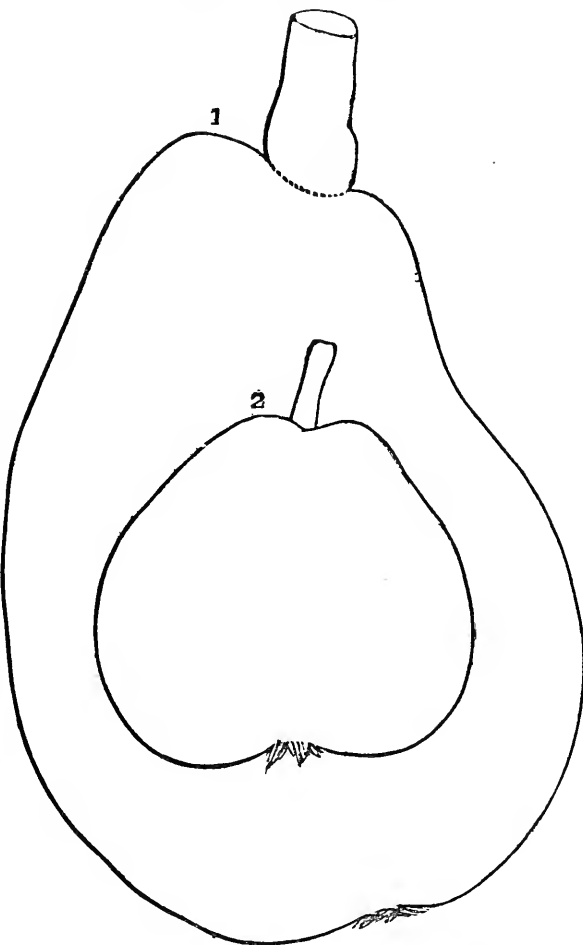

This kind produces annually an abundant crop. The fruits are borne in clusters of four or five together. The tree is one of the most vigorous growers in the nursery, of pyramidal form, nevertheless the branches spread at right angles with the stem. The wood is a reddish brown, covered with large light gray dots, short jointed; buds short and point outward; the leaf stalks are of a rose color at the base. It is yet but very little known; but when it becomes more so, it must occupy a place in every well assorted fruit garden.

THE BRADSHAW PLUM.—I noticed your description of the *Bradshaw* plum, in the October number of the *Genesee Farmer*, with some interest, because it is a particular favorite of mine. Your description is correct as far as it goes, but you failed to notice a peculiar feature in the insertion of the stem on a protuberance resembling a small button lying flat on the end of the plum. This feature belongs to nearly all the large specimens. I have trees of this variety which have borne for several years, and the fruit has been uniformly fair and never in the least been affected by cracking or rotting on the tree, while that of every other variety in my collection has been more or less affected in that way. I suppose you inadvertently substituted the name of Judge BURROUGHS in place of mine, and South Bend in place of Plymouth. If so, be so good as to correct. GROVE POMEROY.—*Plymouth, Ind.*

We are much obliged to Judge POMEROY for calling our attention to the error we committed in referring to Judge BURROUGHS, as well as for the valuable information he gives us from his experience in regard to this excellent plum.

THE BAILEY SPICE APPLE.—JOHN W. BAILEY, Esq., of Plattsburgh, N. Y., sends us the following note in regard to our notice of his apples. It is possible we are mistaken in regard to the identity of the *Bailey Spice* and *Pomme Royal*—another season will satisfy us.

In your notice of the apples I sent you, you say that the *Bailey Spice* is so much like the *Pomme Royal* or *Dyer* as to leave little doubt, in your mind, of their identity. The *Bailey Spice* originated in my orchard; the tree is more than fifty years old. I am quite confident that scions of this variety have never been given out except by myself, and that within the last five or six years under the true name, and I therefore conclude that there is *no doubt of its being distinct from every other variety*. I have no doubt when you see fair specimens of the *Walworth*, you will form a higher opinion of it. JOHN W. BAILEY.—*Plattsburgh, N. Y.*

J. R. COMSTOCK, Esq., of Mabbettsville, Dutchess county, New York, writes us as follows:

The best November pear we have had this year is *Epine Dumas** of Mantel city, of New York. *Form*—long, varying from oval to obtuse pyriform. *Color*—greenish yellow. Lasts the whole month—has been “best” four years in succession on both pear and quince stocks. *Josephine de Malines* bore this season—is ripe now—would be very fine indeed if not a little too astringent. *Winter Nelis* is an October pear three years in four. The great and never-failing winter pear here is the *Easter Beurre* on sucker pear stocks, that fill the ground as full of fibrous roots as the quince. We grow it on a warm gravelly loam, on the south side of a hill, near the base.

* *Duc de Bordeaux*. It proves with us a remarkably prolific and good pear.—ED.

S. W. COLE, Esq., late editor of the *New England Farmer*, author of “*Cole's Fruit Book*,” died at his residence, near Boston, Mass., on the 3d of January. He was long connected with the agricultural press, and his death will be widely regretted. He was an industrious, observing man.

WORK FOR THE MONTH.—Very little can be done in the garden or orchard during the month of February. *Old apple trees* that have been neglected until the heads are become dense and twiggy, may be thinned out at any time; *scions* may be cut; *poles* for peas and beans, and supports for climbing plants, rustic baskets, flower stands, or other ornaments, may be constructed; *manures and composts* collected, turned, mixed, and prepared for application; *implements* may be put in order; and various arrangements made that will facilitate operations in the spring. Those who intend to use *hot-beds* may be getting them in readiness for the middle of March. The *fruit room* will demand attention; and it must be remembered that the conditions most favorable to preservation are dryness, coolness, and uniformity. Warm air should never be admitted among fruits, as it creates moisture by condensation, and this promotes decay. All unsound specimens should be removed at once, and nothing like decaying vegetables, or anything that emits an offensive odor, be for a moment permitted near the fruits.

A NATIONAL PARK.—Our government at Washington has really taken one step towards the formation and improvement of public grounds. 150 acres of land within the city of Washington is to be converted into a magnificent park, embracing four or five miles of carriage drive, foot walks, ponds, fountains, statues, &c., and a complete collection of the trees indigenous to North America. The plans have been given by A. J. DOWNING, Esq., and the work is to be executed under his superintendence. It is supposed that three or four years will be required for its completion.

The question of a great park in the city of New York is also *agitated*, but the New Yorkers hardly know what a park means. Philadelphia is also moving in the same direction. The times are brightening.

FRUITS FROM FRANCE.—MR. ANDRE LE ROY, of Angers, France, sent to the Massachusetts Horticultural Society a case of fruits for exhibition, comprising 116 varieties of pears, 36 of apples, 12 of crabs, walnuts, chestnuts, &c.; and we learn from Hovey's Magazine, that only about 30 varieties of the pears, and the same number of the apples, arrived in good order, owing to detention in England. Mr. LE ROY has, in a recent communication to us, expressed his intention of sending a collection to our next State Fair. So much for steam communication. Europe and America will soon be making exchanges of fruits on an extensive scale.

THE SEASON.—The winter here set in unusually early, and up to this time (Jan. 10) has been marked by extreme severity—a continued succession of hard frosts and heavy falls of rain and snow. On the night of the 2d of January the mercury fell 10 deg. below zero—a degree of cold seldom experienced here. No serious injury is yet done to fruit trees or the wheat crop, and now we have a fine warm coat of snow eighteen inches deep. We trust the close of winter will be more temperate than the beginning.

THE NORTH AMERICAN SYLVA.—A new edition of this magnificent work of MICHAUX, on the Forest Trees of North America, with NUTTAL's continuation, has just been issued by ROBT. P. SMITH, of Philadelphia; the whole forming six volumes royal octavo, with 278 plates. This will be a real treasure to every man who can afford to place it in his library. Price, \$45 dollars with colored plates; \$31 uncolored.

English Agricultural News.

REAPING MACHINES IN ENGLAND.—We were not surprised at the success of McCormick's Reaping Machine in England, but we were certainly surprised that it should gain such a decided advantage over Hussey's as for a time to throw it entirely in the shade. We were satisfied either that Hussey's Machine was not in proper order, or was managed by some one ignorant of its use. The latter appears to have been the case, according to the London Farmer's Magazine, from which we quote the following:

"A porter from the exhibition, [possibly a *cockney*,] who had never seen wheat in his life, was on the first trial sent to work Hussey's Machine, who did not know how to set it; the consequence was, it left a high stubble and did not work well. McCormick's had a better fate, and won the 'Great Medal.' Hence he challenged the world, at the Cleveland Agricultural Society, and Hussey or his agents accepted the challenge. Twelve practical farmers were appointed to decide on the merits of each. The day was fixed, and though it was most unpropitious, yet a vast concourse of people assembled; and though it rained 'cats and dogs,' with a strong wind, yet the small, snug, simple, Hussey's Machine cut down its breadth of corn closely, evenly, and well. It was a triumph! Two horses walked gallantly away with the machine, nor did it seem to distress them, while little effort seemed to be necessary to receive the corn from the well arranged platform on which the lancets, for such they are, left it after cutting. There were no ugly and ponderous flappers—no array of useless work, but a condensed, simple arrangement of parts necessary to effect its purpose. McCormick's Machine came next to the trial; but it would not work at all. It operated more like a roller; it refused to cut the corn; and the trial was abandoned."

The jury, on account of the unfavorable state of the weather, separated without making any award. Another day was fixed, and the machines tried on wheat and barley; when the jury unanimously decided in favor of Hussey's Machine.

"By a vote of eleven to one, Hussey's Machine caused the least waste, did the most work, leaves the cut corn in the best order for gathering and binding; and unanimously, that Hussey's is best adapted for ridge and furrow, and at first cost is less price, and least liable to get out of order."

AMERICAN PLOWS IN ENGLAND.—At the Storrington Farmers' Monthly Meeting, the subject for discussion was "Agricultural Implements, and Horses." We give a few extracts:

"Mr. HARDWICK said: 'The first and most important implement on a farm is the plow. It is made on various principles adapted to the different soils and purposes for which it is required. Hence it is impossible to point to any one particular plow, and say, 'This is best,' unless the description of soil and the precise operation it is to perform be at the same time pointed out.

"The roller is also an implement indispensable to the agriculturist. A wooden one—though in my opinion not so good as an iron one of larger circumference, and in two parts—is most extensively used, the first cost being small.

"The drill is an implement extensively used in depositing the various seeds. Many think there is great advantage in drilling over the broadcast system. My own opinion is, that the difference in the two systems, if carefully noticed with regard to the weight of the crop, would be found to be very trifling. I am, nevertheless, of opinion that the drill in many cases is a very useful implement.'

"Mr. LEAR said: 'I will just draw your attention to the American plows, which perhaps some of you have seen at the exhibition. That they have been pretty well ridiculed I know; but that does not detract from their value; and I am inclined to think they are well adapted for the work they are intended for. The turn-furrow is exceedingly well shaped, and in fact is a business-looking thing altogether.'

"Mr. W. BARTCOCK said if any of them had an inclination to inspect one of these plows, it might be seen at Major SANDHAM's farm, and also some work it had performed. He [Mr. B.] was perfectly satisfied of its usefulness on light soils, for preparing the barley or turnep season. It required but one horse to draw it. [Hear, hear. 'That's the sort we want.'] He was aware this could not be done on heavy, stubborn land; but for the purposes he had mentioned, it appeared to him a very useful implement."

FROM a private correspondent we learn that farmers generally are putting forth all their energies to meet the low price of their products caused by the removal of protective duties. They are growing more green crops and keeping a larger stock, and are thus able to make ends meet. The contemplated alteration in the franchise will strengthen the free trade, manufacturing, liberal party, and so relatively weaken the landed interest.

Editor's Table.

Our friends who are laboring to increase our circulation, in all parts of the country, are placing us under great obligation, which we shall endeavor to repay in part by sparing neither money nor labor to make our journal meet their most sanguine expectations. Additions can be made to clubs at any time, at the lowest club price. Those who have forwarded clubs of five can increase to eight by forwarding \$1. The Post Office law does not allow us to send receipts; and those who receive the paper, unless we write them on the subject, may consider it as such.

ANSWERS TO INQUIRIES.—We endeavor to answer inquiries so as to be understood by all. To do this we have to occupy considerable space. Those who have made inquiries and received no answers, must exercise patience, as all shall receive attention soon. During the winter season farmers have leisure to write, and we are pleased that they embrace the opportunity. We often, at this season, receive enough matter in a day to fill a number of our journal. All shall have a hearing in due time.

LADIES' DEPARTMENT.—Although we have given no pages under this heading, Mr. BARRY has occupied the room with descriptions of flowers, &c., that we know will be acceptable to our female readers. All who have applied for seed shall be furnished in season for spring planting. We intend to commence descriptions of the best annuals, in our next.

POULTRY PROFITS.—EDW. DIMMICK, of Pleasant Mount, Pa., gives his poultry account, for the past year, as follows:

Kept fifteen hens and one cock, from which we received

100 dozen eggs, at 13 cents,.....	\$13 00
29 chickens, at 13 cents,.....	11 70
Cost of feed,.....	10 00
Profit,.....	\$14 70

LARGE HOG.—D. EDWARDS, of Little Genesee, N. Y., writes, Nov. 11: "We yesterday killed a hog twenty-seven months old, connected with the Leicester family, that weighed 800 lbs. He has had none but common keeping until this summer. We have given him his feed in a sour state, and fed but three times a day."

We suppose our western friends can beat this, but as we don't pretend to compete with them in the pork line, they must let us boast a little among ourselves.

PLANTING POTATOES IN THE FALL.—C. D. HART, of McLean, N. Y., suggests the idea of planting potatoes in the fall. He states that O. WISO, of Cortland county, has pursued this course, and the yield is much better than with those planted in the spring.

TRYING LARD.—"A Farmer's Wife," of Mount Morris, N. Y., wishes us to state, for the benefit of other farmers' wives, that a table-spoonful of saleratus to a pailful of lard, put in soon after it begins to heat, much improves the quality, rendering it a pure white. A little more attention than usual is necessary to prevent its burning.

Inquiries and Answers.

COAL ASHES AND SAW-DUST AS MANURE.—A gentleman of Henry county, Ky., wishes to know the value of saw-dust as manure, and the best means of hastening its decomposition; and E. APPLETON, of Pittsburgh, and others, inquire as to the value of coal ashes.

Saw-dust contains from four to ten pounds of nitrogen per ton. This would indicate that its manuring value was a little higher than wheat straw, but it is much more difficult to decompose and render fit for assimilation by the plant. If plowed in in its natural state, it would do good, but not to that extent the above account of its composition would lead us to think, owing to its insolubility and difficulty of decomposition. A pound of nitrogen can not be bought in guano or sulphate of ammonia for less than twelve cents per pound; so that saw-dust, compared with these manures, would be worth on an average eighty-four cents per ton. We think it could be profitably used as an absorbent of liquid manure, by being placed at the bottom of the barn-yard, or in some place where this liquid runs; it would thus imbibe the water, and a decomposition would take place, and at the end of a year or so you would have a most valuable manure, inasmuch as this liquid which in so many instances is allowed to run away and be lost, is by far the most valuable portion of the manure, containing all of the alkaline phosphates and a greater part of the ammonia; these would unite with the saw-dust and not only be exceedingly valuable themselves, but convert the saw-dust itself into a good manure. We hope our friend will try one or both of these plans, and give us the results. Chemistry, to be of much

value to agriculture, must have the aid of the practical farmer, who can carry out the indications of science and disprove or establish them by practice.

Coal ashes in England are quite plentiful, coal constituting the whole of their fuel. They are mostly preserved with care and used with guano and sulphate of lime, serving to increase the bulk and enabling the *drill* to distribute these concentrated manures evenly over the soil. They are also used as a manure for meadow grass and clover with beneficial effect. They are also very useful to mix with nightsoil, absorbing the fluids and rendering its removal and application to the soil less difficult and disagreeable. On the whole, we are inclined to think their value is to be attributed to their mechanical effects on the soil, rendering it more porous and absorbent, rather than to any chemical ingredients they may contain. It is often used by market-gardeners in forming beds for early seeds, and is particularly commended as a manure for radishes.

METHOD OF CURING HAMS.—In answer to inquiries on this subject, we give the awards of the Maryland State Agricultural Society, at its last exhibition. The method of curing is wisely given in each case. The hams of Virginia and Maryland have long been celebrated.

T. E. HAMILTON'S RECIPE.—*First Premium.*—To every 100 lbs. pork take 8 lbs. of G. A. salt, 2 oz. saltpetre, 2 lbs. brown sugar, 1½ oz. of potash, and four gallons of water. Mix the above, and pour the brine over the meat, after it has lain in the tub for some two days. Let the hams remain six weeks in brine, and then dried several days before smoking. I have generally had the meat rubbed with fine salt when it is packed down. The meat should be perfectly cool before packing.

J. GREEN'S RECIPE.—*Second Premium.*—To 1,000 lbs. of pork, take half a bushel and half a peck of salt, 3 lbs. saltpetre, 3 lbs. sugar, and two quarts of molasses. Mix—rub the bacon with it well; keep on for three weeks in all; at the end of nine days take out the hams, and put those which are at the top at the bottom.

R. BROOKS, JR.'S RECIPE.—*Third Premium.*—One bushel of fine salt, half bushel ground alum salt, one and a half pound to a thousand pounds of pork, left to lie in pickle four weeks, hung up and smoked with hickory wood until the rind becomes a dark brown.

C. D. SINGLUFF'S RECIPE.—*Fourth Premium.*—To 100 lbs. green hams, take 8 lbs. G. A. salt, 2 lbs. brown sugar or molasses equivalent, 2 oz. pearl ashes, 4 gallons water; dissolve well, skimming off the scum arising on the surface. Pack the hams compactly in a tight vessel or cask, rubbing the fleshy part with fine salt. In a day or two pour the above pickle over the meat, taking care to keep it covered with pickle. In four to six weeks, according to the size and weight of the hams, (that is to say the longer period for heavy

hams) hang up to smoke, hook up, smoking with green hickory wood. I have put up hams for the last 12 or 15 years by the above recipe with uniform success, equal at all times to the sample now presented.

RAT-PROOF GRANARY.—**YELLOW BUG.**—The best rat-proof granary within my observation is set on posts smoothly turned, and sheathed with tin about a foot in width from the upper end. The posts stand three feet out of the ground, and the steps are hung on hinges or pivots, to be raised and turned in when the granary is closed. No rat ever dined in that crib.

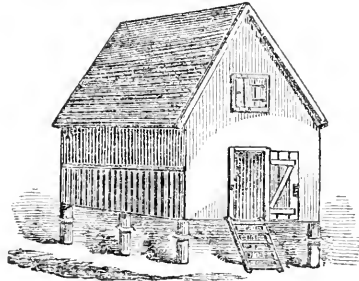

RAT-PROOF GRANARY.

The lower floor is used for corn, (both sides being neatly slatted,) and the second (reached from the first by stairs swung on pivots as before) for the smaller grains.

Although out of season, it may prove of advantage to some of your subscribers another year to know how to prevent the ravages of the "yellow or striped bug." Tansy failed entirely, so far as my experience was concerned. If manure dissolved in water and sprinkled on the vines, succeeded tolerably well, but required constant watching and repetition. But the best method for a limited number of plants, as I think, is to set over the hill as soon as they appear, open boxes eighteen inches square and six to eight inches deep, gathering the earth about the bottom to prevent their crawling under. In the same garden, during the last summer, those vines which were protected by tansy were covered with bugs, while those inclosed in boxes, only a few feet distant, escaped unharmed. A dozen or two of such boxes can be made in a few hours on some winter's day, out of old fence boards, if need be, and had in readiness for the summer's use.

RAT-PROOF GRANARY.—I noticed in one of your numbers an inquiry for a rat-proof granary. In answer to that, I will only give the form of mine, which so far has had the desired effect. I make it as tight all round as convenient with common lumber, except a place in the center, overhead, for the rats to go in if they would; but seeing no way to get back, they do not like to jump through the hole. This I think prevents them from gnawing at any other place. The hole must be in the ceiling, under the joist, and a floor over it, so the rats can have free access to the hole. P. S.—*Rotlin, Mich.*

GAS LIME.—In your January number is an inquiry as to the value of gas lime in the destruction of the larvae of the May bug, &c.; and having used a little, as also the tar, some eight years since, I give you the result of my experience. My garden, which was a light sandy loam, was much infested with the centipede and the larvae of what is called in some parts of England the Fern Shaw, a small brown beetle rather less than the Rose bug, and which in its perfect state is exceedingly destructive to apples, pears, peas, &c., &c. In October I spread a load of lime fresh from the gas works on about three rods, and dug it in immediately, thus absorbing the ammonia which was passing off freely. In the spring following I planted with early potatoes, manuring as usual with stable manure; and the crop was certainly more free from the ravages of the centipede than any I had before raised, and but few of the insects were found; but as to the larvae of the beetle, I did not perceive any diminution in their numbers, nor was there any marked increase in the crop.

To one gallon of the tar I added one pound of sal soda and ten gallons of boiling water. This mixture I applied to a part of a row of peas, and to the remainder pure water. The part to which the mixture was applied made a much larger growth of haulm without a corresponding increase of pods. This increase, I have no doubt, was due more to the soda than the tar. I also applied the tar undiluted to the stems of some old gooseberry trees that had been infested very much with the caterpillar the previous summer, and the application proved fatal to the trees. L.—*Brooklyn, N. Y.*

APPLICATION OF MANURE.—I wish to learn through your paper, as I have had access to it but a few months, something of the use of manure—the most economical way of applying it. I mean manure that is made through the summer season, from the droppings of cows, &c. I gather up the droppings and mix well with dirt through the summer; usually in the fall I have carted it out, and sometimes spread it on green sward and plowed it in, when I intended to plant even the coming season; and sometimes I have, after digging my potatoes, spread it on and plowed it in, where I intended to seed down to grass the coming season; and my expectations have not been fully realized. I wish to know your opinion in spreading it on as a top-dressing for grass, and at what time it should be used as a top-dressing. I used it in this manner for the purpose of getting it out of the way, and so that it might not dry up and thereby lose its strength. I also wish to know the best way of using soap-boilers' ashes, whether to sow on grass ground, and at what season, in the fall or spring, or to put them on the land where we sow down to grass.

A FRIEND TO AGRICULTURAL KNOWLEDGE.

1st. Be sure to save all the liquid as well as solid part of the manure voided during both summer and winter. This can be done by bedding cows, and other domestic animals, on any absorbent substance, like dry swamp muck, loam, straw, forest leaves, and the like.

2d. On open, porous soils, and such as are inclined to surface wash, (hill sides,) it is best to apply manure in the spring before grass starts, or at that time; but on retentive soils, to apply manure in the fall and turn it under for a spring crop, is sound policy. If applied to a meadow, or

pasture, we should harrow the surface, partly to incorporate the manure or ashes with the soil, and partly to give the grass plants a new start by a kind of root pruning. Thus treated, land will retain all, or nearly all, of the fertilizing elements applied to it.

3d. Soap-boilers' ashes are greatly improved by mixing lime with them, say at the rate of one bushel of recently slaked lime to three or four of ashes. On soils that lack lime, equal parts of the two would be better. If we had the time at our disposal, we should apply the food of all plants to the earth where they are to grow only a few days before said plants were expected to begin to consume it. But circumstances vary all general rules indefinitely.

HORTICULTURAL

Two apples have been received from Mr. Jos. PATTERSON, which Mr. P. states in a note originated in the orchard of his father, AMOS PATTERSON, in the town of Union, Broome county, N. Y., and called in the neighborhood *Patterson Sweet*—suggested by Mr. B. to be the *Bailey Sweet*. This apple looks and tastes so much like the *Bailey Sweet*, that we dare not say it is not it. The specimens were too ripe to determine correctly.

(C. D. H., McLean, N. Y.) A correspondent has taken up the subject of the Grape Vine, and will probably give you the desired information. The *Fruit Garden* is \$1.25—postage 20 cts., prepaid.

(B. J., Wilkins, Allegany county, Pennsylvania.) The tree of which you enclose a piece, is the *Taxus canadensis*, (American Yew.) It does not flourish in the sun. The *Cupressus thuyoides*, or white cedar, is different from the American arbor vitae, although the latter is generally called white cedar in this part of the country. It is a lofty tree, with somewhat drooping branches, and foliage, in appearance, between the arbor vitae and red cedar. It abounds in swampy grounds in New Jersey, and southward. We are much obliged for your drawings.

APPLES.—(P. J. W., Fort Plain, N. Y.) No. 1 is *Rhode Island Greening*. No. 2, *Westfield Seek-no-further*. No. 3, don't know. The seeds will be sent out in time.

BUCKTHORN HEDGE.—(E. C. S., Wauwatosa, Wis.) Prepare the ground as you would for wheat or corn, and get two year old plants at about \$10 per 1000. Plant in a single row at six inches, or in a double row at twelve inches apart; about 1800 for 100 rods.

(J. G. C. L.) Leap year, as such, has nothing to do with the success of grafts. A silly old whim, sure enough!

(J. G., Mohawk, C. W.) We do not know where seeds of ornamental trees or shrubs can be found now. You might secure them by applying to the nurserymen or seedsmen in the summer.

(J. C., Creages, Md.) Get your trees early in the spring. Send your order to the nurserymen early.

(P. M., Sylvania, Pa.) We do not know where cherry and quince seeds can be obtained now. Such things should be ordered in season—cherry in June and quince in October. Seeds are generally saved but to order.

(J. P. II., Charlotte, Mich.) The insect you describe was the *rose bug* itself, and your mode of destruction was as good as any we know. They are destructive, voracious, and almost unconquerable.

HOT-BEDS.—(J. P., Pomfret.) A hot-bed frame is simply four boards, or four pieces of one and a half or two inch plank, made into two sides and two ends, one side being twice as deep as the other, the ends sloping from back to front at such an angle as will throw off the rain and admit sufficient light. The ends and sides may be nailed together, or attached by hooks and staples; the latter is more convenient for taking them apart to lay away. Small rafters of two inch stuff, four inches wide, are placed across and let into the sides to support the sashes. The sashes are made of any desired width—three to four feet—and as long as the hot-bed is wide. It is made as a window sash, but without cross bars, except one in the middle to keep it firm. The lights are overlapped an eighth to a quarter of an inch. Use good, strong, clear glass, free from specks. The number of frames you want will depend upon the extent of your proposed operations. This you must determine. In forcing largely, it is well to have some pretty large frames. These you must get ready in season, and also plenty of stable manure. You can begin to force about the first to middle of March. We will endeavor to give you some further information, but would advise you to get BRIDGEMAN'S or BUIST'S treatise on Kitchen Gardening, as we can not go into all necessary detail short of writing a book. Get our volume for 1849.

(R. P. R., Chittenango.) We will endeavor to give you some facts respecting circulation of sap in plants. The egg plant is grown like a tomato. The plants should be started in a hot-bed before putting out in the garden. The fruit is cut in

thin slices and fried in batter usually. There is no possible way of producing several sorts in one, but a number of varieties may be obtained on one tree by grafting or budding.

(J. D., Corydon, Ind.) Seeds of the arbor vitæ can not be obtained here now; the other seeds will be sent in season.

"TWENTY BEST PEARS FOR GENERAL CULTIVATION."
—(D. E. G., Haviland Hollow.) We can heartily recommend you the following: *Summer*—Madelaine, Bloodgood, Dearborn's Seedling, Bartlett, Osband's Summer, Tyson. *Autumn*—Beurre Diel, Beurre Bosc, Belle Lucrative, Louise Bonne de Jersey, Duchesse d'Angouleme, Doyenne Boussock, White Doyenne, Swan's Orange, Seckel. *Winter*—Vicar of Winkfield, Winter Nelis, Lawrence, Princess St. Germain, Pound. If six varieties of summer pears are too many, strike out some and add Flemish Beauty and Van Mons Leon le Clerc.

(J. C., Indian Spring, Pa.) We can not, without more information, venture a decided opinion in regard to the disease that affects your apples. It may be the soil is too cold, wet, or sour—may need draining, deep plowing, and manuring. It must be owing to the absence of necessary ingredients of food in the soil, or the presence of some injurious one. Lime can not cause it, for the apple is always finest on limed and limestone soils.

OSAGE ORANGE.—(J. D. A., The Square, N. Y.) You can get the seed through any of our seed stores, at about one dollar per quart. Soak it 24 hours in warm water before sowing. Sow in drills in light soil, and cover an inch deep. The plants are fit for a hedge row at one year old; and if well planted and taken care of, will make a good hedge in four years. It is a little tender. The Buckthorn is a hardy, rapid growing, fine hedge plant; but neither so thorny nor so elegant in foliage as the Osage Orange.

THE PAWLONIA.—(J. C., Mechanicsville, N. Y.) It is true that this tree can be propagated from pieces of the roots; but it does not follow from this that it will throw up suckers, unless special means be taken to produce them. We have never seen the appearance of a sucker, nor heard of any, and therefore we think apprehension on this point needless. The roots of almost any tree can be forced to emit suckers.

ONIONS.—Will some of our good kitchen gardeners answer the following:

If it would not be out of place, I should like to ask you a few questions in regard to the cultivation of onions. We have anxiously looked over the Farmer for information on this subject, but could find none. We wish to know when to plant to ensure a good size; what time to gather seedlings, as we use top onions, or sets; whether it is of use to break the tops to increase the bottoms. We have experimented three years, and have had no success in preserving seedlings through the winter. Please inform on this subject. S. A. D. F. K.—Columbus.

NEW AND IMPORTANT INSURANCE.
Northern New York Live Stock Insurance Co.
Plattsburgh, N. Y.

INCORPORATED by the Legislature of the State of New York, July, 1851. Horses, Cattle, and all kinds of Live Stock insured against death, by the combined risks of Fire, Water, Accidents, Diseases, &c. Capital, 50,000.

DIRECTORS.

James Farr, Washington co.	Amasa C. Moore, Clinton co.
Joseph Potter, do.	John Boynton, do.
Olif Abell, do.	Zephaniah C. Platt, do.
Pelayiah Richards, Warren co.	Cornelius Halsey, do.
Walter Geor, do.	James Averill, do.
Wm. E. Calkins, Essex co.	Jacob H. Holt, do.
Albert Andrus, Franklin co.	Peter S. Palmer, do.
John Horton, St. Law. co.	George Moore, do.
Thomas Cankey, do.	Henry G. Hewitt, do.

JAMES FARR, President.
 A. C. MOORE, Vice President.
 G. MOORE, Plattsburgh, Secretary.
 Z. C. PLATT, do., Treasurer.
 I. C. MIX, Fort Ann, General Agent.

October 13, 1851.

This company is now organized and ready to receive applications for insurance. It is confidently believed that the owners of valuable animals will avail themselves of the advantages offered by this mode of protection.

The company have adopted such rates as, they believe, will furnish the means of paying ordinary losses, without resort to an assessment. But to guard against extraordinary losses, which may arise from contagious diseases or epidemics, it becomes necessary to require premium notes.

TO THE OWNERS OF HORSES AND LIVE STOCK.

Office of the Northern N. Y. Live Stock Ins. Co., }
 PLATTSBURGH, August 16, 1851.

The Directors of the above Company, incorporated by the Legislature of the State of New York, at its extra session in July, 1851, respectfully request your attention to the following facts bearing on this subject.

1st. Value of this class of property. By the census of 1845, there were at that time in the State of New York, as follows:

	<i>Horses.</i>	
One-half a million,.....		505,155
	<i>Neat Cattle.</i>	
Over two millions,.....		2,072,320
	<i>Cows Milked.</i>	
Nearly a million,.....		999,490
	<i>Sheep.</i>	
Over six millions,.....		6,442,855
	<i>Hogs.</i>	
Over one million and a half,.....		1,584,344

Without making any estimate of the value of this property, it is apparent that it is immense; extending to every inhabited spot, and essential to the health and comfort, almost to the existence of the inhabitants.

2d. These animals are subject to disease and accident. It has been asserted as a fact which can not be disputed, that the aggregate loss upon this species of property is greater than the losses by fire; at all events, it is a fact undoubted that the annual loss is very great, and the owner is left unprotected with any means of security against the hazard incident to this description of property.

3d. The knowledge of this risk is one of the leading hindrances to improvement in the breed of that useful and noble animal, the horse.

Men of capital are slow to invest large sums in a valuable animal, whose loss they must every day risk, to the amount often from five hundred to a thousand dollars, in every valuable breeding horse.

With the ample security to be afforded by sound Insurance Companies, the investment of capital in horses and live stock may be made as safe and safer than the carrying of freight on the seas and inland waters. Marine Insurance has rendered this last business steady and profitable; while without it, it would want the confidence which that branch of business now commands. The absence of this Insurance in the case of live stock is universally felt.

While the owner of real estate can command half or two-thirds of its value, when needed for an emergency; while the owner of the ship, "the plaything of the wind and waves," may obtain any reasonable advance; the owner of equally valuable property, invested in horses and cattle, can not obtain a dollar. The only exception being fat cattle destined for market. In vain does the owner of the horse appeal to his industry or usefulness. The answer is,

that his property is liable to disease and accident, and that as security it is utterly worthless.

4th. The Insurance principle comes in, and does for him what life Insurance has done for the young beginner in trade, taking away the risk arising from the uncertainty of life.

It will do for him what Fire Insurance has done for the owner of personal property; placing him nearly on a level with the owner of real estate.

It will do for him what Marine Insurance has done for property "afloat," taking away or equalizing the risk of the elements.

5th. In short, if Life, Fire, and Marine Insurance, are proper and expedient; so is Live Stock Insurance; as they all rest on the same foundation—that of mutual help and assistance.

Your aid is respectfully solicited in behalf of the Company, the first chartered in this State for this object. The Directors intend it shall be prudently conducted, and one which shall deserve the confidence of the public.

Our Capital is fifty thousand dollars; and when estimated in view of the liabilities we seek to assume, will be found as large or larger, in proportion, than the usual capital of Fire, Life, and Marine Insurance Companies; those Companies often taking single risks of from three to five thousand dollars, while in our case no single risk will exceed four hundred dollars.

Terms of Insurance will be furnished by Agents of the Company.

New York Agricultural Warehouse.

A. B. ALLEN & CO.,

189 & 191 Water Street, New York.

PLOWS of a great variety of patterns and different sizes calculated for sward and stubble land, wet meadows and recently drained swamps, where roots abound. Among these plows, also, are the deep-breaking-up, flat-furrow, lap-furrow, self-sharpening, side-hill, double mould-board, corn, cotton, cane, rice, and subsoil, with single or double wings.

HARROWS—Triangular, Square, Geddes, and Scotch. **ROLLERS** with iron sections one foot long, and of different diameters. These can be arranged on an iron shaft of any width.

CULTIVATORS of upwards of twenty different kinds, steel tooth and cast iron.

SEED SOWERS of six different kinds and prices.

HORSE POWERS—Endless chain and circular, of wood or cast iron.

THRESHERS, with or without Separators.

GRAIN MILLS of cast iron, and burr stone, to work either by hand, horse, or water power.

CORN SUELLERS, single and double, large and small, cylindrical to work by hand, or otherwise.

STRAW CUTTERS with spiral, straight, or circular knives.

VEGETABLE CUTTERS, for turnips and other roots, together with a great variety of all other Agricultural and Horticultural Implements kept in the United States, such as hoes, shovels, spades, rakes, manure and hay forks, grain cradles, scythes, snaths, &c., &c.

CASTINGS of all kinds, for plows, cotton gins, and rollers.

WAGONS AND CARTS, for horse, ox, or hand.

STEAM ENGINES, for farm and other purposes.

Our Implements occupy three large stores, and we believe they make up the largest and most complete assortment in America. In addition, we have a machine shop employing upwards of one hundred men, where any articles in our line can be made to order.

A. B. ALLEN & CO.,

Feb., 1851. 189 and 191 Water St., New York.

York County Farm for Sale.

ANY gentleman wishing to remove South, can be accommodated with a good Farm of 250 acres, about 70 acres open, level, abundance of marl, orchard and small dwelling, very healthy, and good water. The residue is well set in Pine, Oak, and Chestnut, and one mile from a bold creek. Any gentleman wishing to purchase, will communicate with the subscriber. EDWARD L. COKE, Feb. 1852.—2-2t*

Wants a Situation,

A GERMAN GARDENER, who has been several years in this country, and is well acquainted with the different branches of his profession. Would prefer a place where there is some glass. He is a young married man with a small family, and can be well recommended.

Address, post-paid, CHARLES MESSIG, care of Dr. SPENCE, Starkey, Yates co., N. Y.

Feb., 1852.—2-1t*

Prices of Agricultural Products at the Principal Markets in the United States.—Jan'y 15, 1852.

	New York.	Boston.	Rochester.	Chicago.	Cincinnati.	Pittsburgh.
Beef, per 100 lbs.	4.25 a 5.75	\$7.00 a 8.00	\$3.50 a 4.25	\$4.00 a 4.50		
do mess, per bbl.	8.25 11.00	11.00 12.50	11.00 11.50	8.00		
Pork, per 100 lbs.			5.00 5.50	3.75 4.00		
do mess, per bbl.	14.87½ 15.00	15.75 16.00	15.00 15.50	16.00 16.50	\$12.50	
Lard, per lb.	9 9½	9½ 11	7 7	9 8	6¼ a 7½	
Butter, do.	14 23	16 20	12 16	8 10	8 11	\$0.15 a 16
Cheese, do.	6½ 7½	7 8	5½ 6	5 7	6½ 7	6½
Flour, per bbl.	4.81 5.25	4.50 6.00	4.00 4.50	3.00 4.00	3.05 3.35	3.00 3.12½
Wheat, per bush.	1.08 1.12½		87½	90 50	65 57	60 60
Corn, shelled, per bu.	67 68	63 68	50 53	28 30	25 30	
Rye, do.	77 78	75 77	69 70	70 70	50 55	40
Oats, do.	40 45	40 45	31 31	17 19	22 23	31
Barley, do.	77 80	95 1.00	67 70	70 70	55 60	46
Clover seed, do.	8½ a 9 pr. lb.	9 a 12 per lb.	4.50 5.00	12½ per lb.	4.50 4.75	5.25
Timothy seed, do.			2.50	2.25	1.50 2.50	
Flax seed, do.	1.35 1.37½	1.60 1.65	1.25 1.50	1.50 75	11.00 13.50	
Hay, per ton.	15.00 16.00	14.00 15.00	8.00 11.00	40 40	26 35	
Wool, per lb.	30 40		30 4.00	3.00 5.00		
Wood, per cord.		6.50 7.00				

CONTENTS OF THIS NUMBER.

Agricultural Chemistry, 41
 The Limited Duration of Varieties of Plants, 44
 Culture of Flax, 45
 Experience in Potato Culture, 46
 "Rural Homes"—A Suburban Cottage, 47
 Plan of a Farm-House, 50
 Butter Making, 51
 Value of Barn-Yard Manure, 52
 Hees Barley, 52
 Growing Flax with Barley, 52
 SHEEP HUSBANDRY—Vermont and the West, 53
 Breeds of Sheep, and their Comparative Value, 54
 ENGLISH AGRICULTURAL NEWS—Reaping Machines in England; American Plows in England, 66
 EDITORS' TABLE—Poultry Profits; Large Hog; Planting Potatoes in the Fall; Trying Lard; Inquiries and Answers; Notices; &c., 67

HORTICULTURAL DEPARTMENT.

The Fuchsia, 58
 Descriptions of new Pears, 63
 The Bradshaw Plum, 64
 The Bailey Spice Apple, 64
 Work for the Month; A National Park; Fruits from France; The Season; The North American Sylva, 65

ILLUSTRATIONS.

Suburban Cottage, 47
 Ground Plan of Suburban Cottage, 48
 Chamber Plan of Suburban Cottage, 49
 Rustic Flower Stand, 50
 Plan of a Farm-House, 50
 Hees Barley, 52
 Fibre of Merino Wool, 54
 Fibre of South Down Wool, 54
 Fibre of Leicester Wool, 54
 Merino Sheep, 56
 South Down Sheep, 57
 Leicester Sheep, 57
 Fuchsia, Pearl of England, 59
 do. Magnificient, 60
 do. Serratifolia, 61
 do. Globosa, 62
 Pear, Bonne des Zees, 63
 do. Benre Derouineau, 63
 Rat-proof Granary, 68

Farm for Sale.

THE subscriber offers for sale her farm, situated in the county of Onondaga, one mile west of the village of Jordan, on the Erie canal, and adjoining the Syracuse and Rochester Railroad. Said farm consists of one hundred acres, and is well adapted for grazing. There is about ten acres of muck, on which carrots, beets, &c., grow to an enormous size. Also, on the farm, and in immediate vicinity, are large deposits of marl. Eight acres wood land. Good dwelling house, barn, and fruit.

For further particulars, inquire of Z. P. MASON, Jordan, Onondaga Co., N. Y. TRIPPIENA AUSTIN.
 Feb., 1852.—2-11*

Wanted,

A FARM containing about 50 acres clear new land—some limestone bottom preferred—with about 40 acres maple or oak. Also a good house and out-buildings. Must be in a good farming district and convenient to churches and schools. Would be preferred on the New York or New Jersey shores, with good facilities for carriage to market by railroad or steamboat.

Address letters, post-paid, to RICE LAWTON, care of JOHN SPRING, 16 East street, Boston, Mass., to which immediate attention will be paid; also stating description of place and price.

Farm for Sale.

THE subscriber will sell his farm, containing 224 acres, pleasantly situated on a main road, 2½ miles west from the village of Attica, through which place the Buffalo and Rochester, and Buffalo and New York City Railroads pass. Said farm is well adapted to a dairy or stock. Rouse 26 by 46, well finished and nearly new. Good barns and out-houses. Two large orchards with plenty of graded fruit. I will sell for \$25 per acre; payment made easy. All health induces me to sell.
 L. PECK.
 Attica, Wyoming co., N. Y., Feb., 1852.—2-11*

Prouty & Mears' Center Draught Plows.

A LARGE assortment can be found at the State Agricultural Warehouse, No. 25 Cliff street, New York.
 Feb., 1852.—2-11 A. LONGETT.

The Practical and Scientific Farmer's own Paper.

THE GENESEE FARMER,

A MONTHLY JOURNAL OF

AGRICULTURE AND HORTICULTURE,

ILLUSTRATED WITH NUMEROUS ENGRAVINGS OF

Farm Buildings, Domestic Animals, Implements, &c.

VOLUME XIII, FOR 1852.

DANIEL LEE & JAMES VICK, Jr., Editors.

P. BARRY, Conducter of Horticultural Department.

Fifty Cents a Year, in Advance.

Five Copies for \$2—Eight Copies for \$3, and any larger number at the same rate.

All subscriptions to commence with the year, and the entire volume supplied to all subscribers.

Subscription money, if properly enclosed, may be sent (post-paid or free) at the risk of the Publisher. Address to

DANIEL LEE,

December, 1851. Rochester, N. Y.

POSTAGE ON THE GENESEE FARMER.—50 miles or under, five cents per year; exceeding 50 miles and not over 300, ten cents; exceeding 300 and not over 1000, fifteen cents; exceeding 1000 and not over 2000, twenty cents; exceeding 2000 and not over 4000, twenty-five cents; for any distance exceeding 4000, thirty cents.

STEREOTYPED BY J. W. BROWN, ROCHESTER, N. Y.

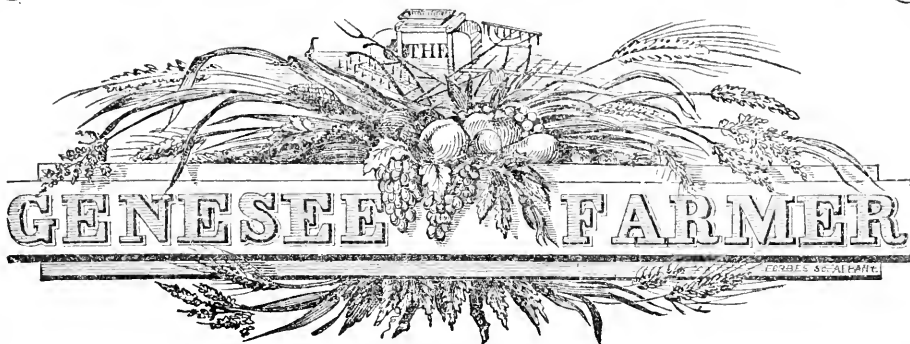

AGRICULTURAL CHEMISTRY.

NUMBER III.

SPECIFIC GRAVITY OF SOILS. — COHESION. — The specific gravity of soils is ascertained by finding how much water a given weight of dry soil displaces. To dry a soil where one has no apparatus designed expressly for the purpose, it may be spread to the amount of four hundred grains on a quarter of a sheet of white foolscap writing paper, which may be placed on another piece of white paper laid on a heated stove. This should be as hot as it can be and not char or burn the paper. The soil should be stirred with a glass or steel rod, or with the blade of a clean knife, to hasten the drying. A paper with soil upon it may be put upon an earthen plate and set in a common cooking stove hot enough nearly to bake bread, where it will, if properly spread out on the paper, dry in thirty minutes. Any heat that does not burn the paper will not consume nor char the mold, or organic matter in the soil. Of this dried soil, weigh out say 357 grains, which may be put into a specific gravity bottle which will hold 1000 grains. (One of a different weight will answer, if the weight be known.) A bottle holding 1000 grains of water ought, when 357 grains of dry soil are added, to weigh 1357 grains, provided none of the water was displaced by the earth. But it is obvious that so much space in the bottle as the solid matter introduced really filled, the water must leave as the soil was added.

Again; if the soil weighed precisely the same per cubic inch as the water, then it is clear that if the bottle were half filled with water and half with earth, the two together would still weigh 1000 grains, or the same that the water alone did; but the result of the experiment may show that the addition of 357 grains increases the weight of the contents of the bottle from 1000 to 1285 grains. Now, as the whole of the water and soil weigh 1357 grains, it is plain that if we subtract 1285 from 1357, the difference is 72 grains, which is the exact weight of the water displaced, and the exact volume of the soil weighing in the air 357 grains — water being the standard. As 72 is to 357, or as the weight of the water is to that of the solid of equal volume, so is 1000 to 4958. In this case the soil or other mineral is 4 and nearly 96-100 times the specific gravity of water. This is heavier than any soil, but not so heavy as iron filings.

The specific gravity of solid bodies of considerable size can not be determined in the manner above described; but it may be the circumstance that water partly supports solids immersed in it, which support is greater or smaller as the body is lighter or heavier compared with its volume. A solid, in order to sink in a liquid, has to displace and push upward a quantity of it equal to its own bulk, and to resist the weight of the liquid, or its tendency to sink down again. To illustrate the principle of the phenomenon under consideration, let us suppose one has a gold coin which, weighed in the air,

gives the right result as to the quantity of metal present ; but there is a well grounded suspicion that the coin contains too much copper or silver. In what way, short of a chemical analysis, can the fact be ascertained ? If the coin contains a lighter metal than gold, (and copper and silver are lighter,) to give the proper weight in the atmosphere it must be as much larger in bulk as there is an excess of silver or copper. Hence, if the coin be suspended in water by a fine silk thread attached to the bottom of the pan connected with one end of the balance, and weights be placed on the opposite pan or scale, less weights will be required to support the coin the larger its volume as compared with its weight in the atmosphere—the support of the water lifting it upward equal to the water displaced. By weighing a coin in the air and again in pure water, if it give the right weight in both instances, it can hardly fail of being genuine. Platinum being a heavier metal than gold, formerly when gold was comparatively dearer than it now is, alloys of gold, copper, and platinum are said to have been formed so near the right specific gravity, that nothing short of an analysis would expose the fraud. Since platinum has risen in price by its extensive use in tipping the ends of telegraph wires, and gold has become unusually abundant, any fraud of this kind would yield no profit if undetected.

All weighing, whether performed by the chemist or the farmer, have for their object to measure the force of gravity of the body weighed. A variety of experiments may easily be tried to illustrate the influence of the surrounding medium on the gravity of bodies, whether in air, water, or quicksilver.

Cohesion is a term used to designate that force which keeps the molecules of matter together. It is usually called “the cohesion of aggregation ;” or “attractive aggregation.” If there was no force antagonist to this, the whole universe would be one solid, immovable mass of matter. The force of *repulsion*, however, so strikingly shown in the air that surrounds the globe, serves to prevent such an aggregation of molecules. In splitting logs for rails and staves, and rocks for building purposes, the farmer has occasion to overcome the cohesive force of both organized and mineral matter. Cohesion is strongly developed in beating gold into leaves of extreme tenuity. A single grain will readily cover 1400 square inches ; and with a microscope the gold on the millionth of a square inch is distinctly visible ; so that without parting with its cohesive attraction, gold may be divided into particles of at least 1-1,400,000,000 of a square inch in size, and retain the color and other properties of the largest mass.

This force of molecular cohesion acts only at a distance so minute as to escape the most delicate examination. The fragments of a piece of glass or metal just broken, when laid ever so closely together, have no tendency to unite again ; but if the surfaces be pressed together, union may take place, though only in a few points, and imperfectly. Yet when the surfaces of plate glass laid flat on each other, and subjected to considerable pressure, are allowed to remain for some time, they are found to grow together so completely, that thick masses may be ground as if they had always formed a single piece. Surfaces of lead may be cut so smoothly that, when pressed together, the cohesive force is brought into play with considerable power. The viscidness of fluids is thought to arise from the same natural law, as is also the globular form of a drop of rain. When a drop of water spreads over a large surface of wood or other solid, the cohesive force between the particles of water and the solid is stronger than that between the particles of water for each other. In the wetting of dry soils, this diffusion of water by the molecular attraction of liquids and solids is strikingly exemplified.

CLAIRAUT found, as the result of his mathematical investigations, that all the phenomena of capillary tubes depend on the relation of two forces : 1st, The cohesion of the particles of the fluid for each other. 2d, The attraction of the solid for those of the fluid. When a glass tube is dipped into different liquids, if the force of the attraction of the glass is less than half the force of cohesion of the fluid, the fluid will be depressed

in the tube, and not rise to its hydrostatic or proper level. If the attraction of the particles of water for each other and for the glass be equal, the fluid will come precisely to its level; and if the attraction between the water and the glass be greater than between atoms of water, the water will rise steadily in the tube. This explains the law of *capillary* attraction and circulation.

A body, when acted on by an extraneous force, if brought into a smaller space, it is said to be *compressible*; if, when the pressure is removed, the body regains its original volume by the mutual repulsion of its own particles, it is said to be *elastic*; if, on the contrary, it remains compressed, it is called *inelastic*. In nature there are but few bodies perfectly elastic, and none which are perfectly inelastic. When the pressure is removed from the so-called inelastic solids, if they have been compressed, a slight expansion occurs; while in gases and liquids the return to the original volume is complete. Solids and liquids are so slightly compressible, that delicate tests are necessary to determine it. A pressure of 400 lbs. upon a square inch of water diminishes it the 1-1000 part. The compressibility and elasticity of gases are nearly perfect and uniform. Thus, air which under a weight of 20 lbs. occupies 100 cubic inches, is reduced in volume to 25 inches by increasing the pressure to 80 lbs.; and it expands to 400 cubic inches if the weight be reduced to 5 lbs. Barometers indicate variations in the weight of the atmosphere, caused, doubtless, partly by the rotation of the earth on its axis and by its course round the sun; and partly by clouds, winds, mountains, vapors, oceans, continents, &c. The essential difference between a barometer and a thermometer is, that the former has a column of mercury which is exposed to the air at its base, having, like a thermometer, a vacuum above the mercury. Hence, the least variation in the pressure of the air on the mercury in the little cup, causes it to rise or fall in the tube. In a thermometer, the mercury is hermetically sealed in the glass, and rises or falls as heat expands or cold contracts the liquid metal.

In some cases gases are brought within the cohesive forces of their particles, which modify their compressibility. Thus, if a tube full of air and a tube full of sulphurous acid gas be subjected to exactly the same pressure, the volumes will not diminish in the same degree when the pressure becomes high, but as follows:

The air as	1000	853	579	314
Sulphurous acid as	1000	851	554	301

In some other gases the same variation has been observed. (KANE.)

Some gases have been liquified by great pressure, and frozen by their sudden expansion when the pressure was taken off by giving vent. Other gases, such as oxygen, hydrogen, and nitrogen, have been subjected to a pressure of 800 atmospheres, equal to 12000 lbs. to the square inch, without causing any change in their natural elasticity, or other properties.

Heat may be regarded as an antagonist power to that of cohesion, and tends to render the molecules of a body repulsive to each other, and to separate them to greater distances than they had been before. When a solid, like salt or sugar, is dissolved in water, the phenomenon is explained by saying that the particles in the solid have a greater affinity for water than for each other. Hence, their previous cohesion is destroyed; they separate in the mass of liquid, which constitutes their solution, or the disappearance of the solid. Substances are *soluble* or *insoluble*, according as the force of solid or liquid cohesion, or attraction, prevails among their several atoms. Bodies insoluble in water, like resins, dissolve in other fluids, such as alcohol, ether, and Seneca oil.

CULTURE OF TOBACCO.

We are receiving many inquiries respecting the feasibility of raising tobacco in the northern and western States, and the best mode of culture adapted to this climate; and though we do not wish to see tobacco raised here as a common crop, feeling assured that it can not be adopted, except on farms contiguous to cities where a large supply of manure can easily be obtained, without ultimately materially injuring the soil; yet we will give the mode of treatment practiced by some who have successfully cultivated it here for a few years past. A dry, sandy loam produces the best *quality* of tobacco; and it is quality and early maturity rather than quantity that should be the aim of the grower.

The seed is first sown in beds, and the plants when about five inches high transplanted out into the field prepared for them. In the southern States, the seed beds are slightly charred or burnt previous to sowing, so as to destroy all the weeds. The beds should be in as warm a situation as possible. If manured with barn-yard manure, care should be taken to have it free from weeds, &c.; and we should prefer to use Peruvian guano or superphosphate of lime sown on the top of the bed or applied as a liquid manure. A table-spoonful of seed will sow a bed ten yards long and ten yards wide. It should be sown as early as the weather will permit. The plants make their appearance in about twenty days, and in six weeks after sowing they are ready to transplant into the field.

The soil should be pulverized to a good depth, and marked off in rows about thirty inches each way, and then the first showery weather the plants should be transplanted; and if any of them die, their places should be immediately filled up. We would suggest, for trial, the application of a tea-spoonful of superphosphate of lime placed below the plant when transplanted. From the magical effect of this manure on turneps, forcing them along during the first stages of their growth, and favoring early maturity, we think it will be a valuable manure for tobacco; the aim of the planter being not to raise a large gross crop, but a small one *perfectly elaborated*, containing a low percentage of ash. For this we believe superphosphate of lime will be found eminently useful.

The after treatment of tobacco is similar to that for the corn crop, the cultivator or horse-plow being kept continually at work as long as a weed is to be seen. The weeds close to the plant should be at first pulled by hand, and afterwards the hoe should be freely used. It is recommended to turn turkeys or other poultry into the field, to destroy insects and worms which sometimes utterly destroy the crop.

When the plant begins to put forth seed heads, which it will indicate by having two leaves of the same length, it should be topped either by hand or with a sharp knife. Shortly after topping it will begin to send out suckers, which must be constantly removed, as they take away much nutriment which is required by the leaves.

The time of harvesting will depend on the culture, soil, and climate. In this vicinity it is ready about the middle of September. It should be allowed to get fully ripe—the the riper the better, though there is great risk in letting it remain out too long, as any early frost may completely spoil it, or heavy rains do it much injury. It may be cut with a sharp knife, such as is used for cutting corn; the head of the plant laid towards the sun for a few hours, and then carried to the drying house.

If the farmer does not grow more than an acre or so, he will probably find room in the barn or some shed, in which to dry the tobacco. This he will best do by getting long poles, and placing them about a foot apart across the building, and to these hanging the tobacco plant by simply fastening the twine at one end of the pole and winding it around the whole length, thus binding the plants to the poles by the butt ends. The plants should not touch each other, and a free circulation of air must be allowed in the room.

If a large quantity of tobacco is grown, and the farmer intends making a business of it, it will be necessary to build a drying shed or room on purpose. The more airy this is

built the better, providing the rain is kept out. The size will of course depend on the number of acres cultivated; but it is better to have too much than too little room, as there is great danger of spoiling the crop if placed too thick in the drying room. When sufficiently dry the plants are taken down and the leaves stripped off, laid in heaps about four feet high to *sweat* for a few days; they are then tied in bundles with a moist leaf, placed in boxes, and sent to market. Tobacco grown in Western New York, and treated in this way, is worth in New York about eight cents per pound. 1500 lbs. per acre is an average crop here.

We have said before it is an exhausting crop, and we should be sorry to see its cultivation extensively adopted by our farmers in the wheat growing districts. In several of the Western States this crop can be profitably cultivated, as the soil and climate is well adapted to its growth, and the cost of transportation *on the money value* is comparatively nothing to what it is on wheat and Indian corn; or, to make our meaning plain, it costs no more to transport 60 lbs. of tobacco than it does a bushel of corn, though one is worth \$48 and the other 48 cents. The same reasoning applies to wool and pork, and everything of a high price, per weight or bulk.

AMOUNT OF WATER GIVEN OFF BY PLANTS DURING THEIR GROWTH.

Mr. LAWES has recently published the result of some experimental investigations of the source and fixation of the various constituents of plants, from which we make a few selections, especially in reference to the amount of water given off during their growth.

The plants taken for experiment were wheat, barley, beans, peas, and clover. The soil used was from a plot on which ten grain crops had been successively grown without having any manure supplied. There were three plants taken of each kind. One set of plants were without any manure; one set with mineral manures added; and one set with mineral manures and muriate of ammonia added. But we must confine our attention at this time to the unmanured ones. Glass jars 14 inches in depth and 9 inches in diameter, capable of holding 42 lbs of soil, were the vessels used. After the vessels were filled, plates of glass having a hole in the center about three-fourths of an inch in diameter in which to place the plant, and another near the side by which to supply the water when it was needed, the latter one being kept tightly corked except while the water was being applied, were cemented on the top of the jars, so as to prevent evaporation from the surface. The scales employed for weighing the plants were constructed on purpose for these experiments, and were calculated to turn with a third of a grain when loaded with from half a hundredweight to a hundredweight in each pan. Between the time of planting and the full growth of the plants more than twenty weighings were taken; and weighed quantities of water were supplied whenever required. The amount of water in

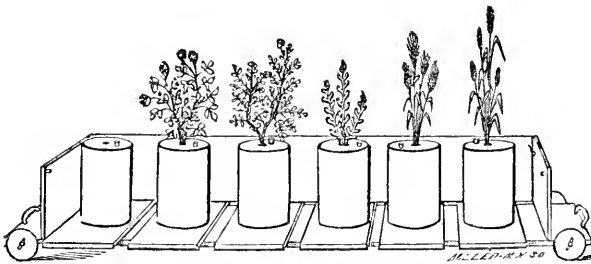

the soil at the time of planting was determined by analysis. The jars were placed on a truck, so that they could be easily drawn into a green-house in case of a shower. The annexed cut will give an idea of the arrangement of the experiment. The empty jar is for the purpose of ascertaining the amount of evaporation through the center hole. The following table shows the amount of water supplied, derived from the soil, and given off by the

plants, during the entire period of their growth — 172 days — from March 19 to September 7. Quantities given in grains, (7000 grains make one pound.)

Description of Plant.	Total Water supplied.	Total Water obtained from Soil.	Total Water given off
Wheat,	79,800	33,727	113,527
Barley,	88,800	31,225	120,025
Beans,	87,800	24,431	112,231
Peas,	81,800	27,282	109,082
Clover, (cut June 28th.)	28,500	26,593	55,093

As has been stated, the jars were often weighed, so that the amount of water given off by the plants during the different periods of their growth could be ascertained. The following table gives the average daily loss of water (in grains) during stated periods of the experiment :

Description of Plant.	9 Days.	31 Days.	27 Days.	34 Days.	30 Days.	14 Days.	27 Days.
	From Mar. 19 to Mar. 28.	From Mar. 28 to Apr. 28.	From April 28 to May 25.	From May 25 to June 28.	From June 28 to July 28.	From July 28 to Aug. 11.	From Aug. 11 to Sept. 7.
Wheat,	14.3	40.9	162.4	1177.4	1535.3	1101.4	230.9
Barley,	14.3	60.2	445.5	1102.3	1592.0	1217.6	237.5
Beans,	9.7	59.8	179.5	885.6	1965.0	901.8	135.4
Peas,	11.2	42.9	106.4	1079.8	2922.7	377.2	..
Clover,	44.4	53.0	109.2	1473.5

As might have been anticipated, as the season advanced in temperature, and the mass and surface of the plants increased, the quantity of water daily given off was greater; yet towards the end of the experiment it rapidly and considerably diminished; and it is probable that the period of the most rapid circulation, as shown by the amount of water exhaled, was that of the greatest *accumulation* of materials in the plant; and that when the evaporation and apparent circulation diminished, the ripening and elaborating processes had commenced.

The clover plant was cut when in full bloom, July 28; the pea, August 11; the other plants, September 7th. The following table will give the total weight of dry matter, organic matter, and mineral matter or ash, in the plants. Quantities given in grains, &c.

Description of Plant.	Total Dry Matter.			Organic Matter.			Mineral Matter or Ash.		
	In grain.	In straw and chaff.	In total produce.	In grain.	In straw and chaff.	In total produce.	In grain.	In straw and chaff.	In total produce.
Wheat,	148.5	310.4	458.9	144.3	278.2	422.4	4.22	32.27	36.49
Barley,	188.7	276.8	465.5	182.5	237.1	419.6	6.20	39.72	45.92
Beans,	282.6	254.9	537.5	273.6	214.9	488.5	9.02	40.00	49.02
Peas,	214.7	206.3	421.0	208.0	169.9	377.9	6.76	36.30	43.16
Clover,	204.7	175.5	29.24

The above table is of little independent interest. It shows that though the soil, previous to the commencement of the experiment, had been particularly exhausted of nitrogen by the growth and removal of ten grain crops without manure; yet with no manure of any kind supplied to the plants in the jars, the grains of the beans and peas, though highly nitrogenous, thrived better than those of wheat and barley. From this it may be inferred that the leguminous plants can and do obtain their large amount of nitrogen from the atmosphere, but that the cereals wheat, barley, &c., are dependent on a supply of nitrogen in the soil. This, too, is consistent with the results of extensive experiments in the field on wheat and beans, the former being greatly benefited by the application of nitrogenous manures, while the latter and other plants of the same botanic order are *not* benefited.

The following table will show the amount of water given off for *one grain* of dry matter, organic matter, and mineral matter, fixed in the plant :

Description of Plant.	No. of grains of water given off for one grain fixed in the plant, of—		
	Dry Matter		Mineral Matter (Ash).
	Inclusive of Ash.	Organic only.	
Wheat,.....	247.4	268.8	3111.2
Barley,.....	257.8	286.0	2618.8
Beans,.....	208.8	229.7	2289.5
Peas,.....	259.1	288.7	2527.3
Clover,.....	269.1	314.0	1884.2

The organic matter was probably derived principally from the water and atmosphere, 268 grains of water being necessary to supply one grain of organic matter in the wheat plant, while in the bean but 229 is used. This would also indicate that the bean possesses the power of abstracting from the atmosphere more of its organic elements than the wheat plant. It is seen that for one grain of mineral matter organized, from 2000 to 3000 grains of water are passed through the plant. This affords evidence sufficient to show that few of the substances usually considered insoluble are incapable of being taken up by the plant in a sufficient quantity of rain water. These figures, when calculated to the acreage yield of wheat, clover, &c., afford some interesting facts. Thus, an acre of wheat of thirty bushels grain and an equal weight of straw would exhale during the spring and summer 355½ tons of water; or, calculated on 173 days, the duration of the experiment, 4,111 lbs. per day. An acre of clover that would make two tons of hay, would pass off through its leaves in 101 days 430 tons, or 8,600 lbs. per day; and this besides evaporation from the soil, which is doubtless great, especially in the case of wheat. The annual fall of rain in different parts of the United States, is from 30 to 40 inches. An acre of water one inch deep would weigh 120 tons. If 30 inches fall in a year, it would be on an average 19,700 lbs. per day per acre. As most rain falls when least required by the plants, the above figures are a potent argument in favor of thorough under-draining, to carry off this immense amount of superfluous water, as well as that arising from springs, which is equally pernicious to the growth of plants.

FLAX CULTURE.

THERE is much discussion in Great Britain at the present time, as to the necessity of paying \$45,000,000 to foreigners for Flax, when their own climate is equally adapted to its growth as that of Belgium and other European countries. It is said that when wheat was from \$3 to \$4 per bushel, land that was not well adapted to its growth was sown, and though the yield was small, yet, from the high prices obtained, it was profitable to grow it. But now, when wheat is but \$1 per bushel, this land can no longer be cultivated with wheat without *serious loss*. What, therefore, shall be done with it? The reply of many intelligent practical farmers is, "cultivate oats, peas, beans, turneps, and flax;" and there can be no doubt that if free trade continues, which it undoubtedly will, a much smaller area of wheat will be sown in future in England. The same thing is true in relation to France. Free trade with England promised high prices for the surplus wheat and a large breadth of land was sown in consequence; but prices are so low that wheat culture in France is anything but a profitable business and will not be so extensive as in the last few years. We therefore predict somewhat higher prices for the future.

At the Penrith Farmers' Club, Mr. ROME, a practical farmer who has been engaged in the culture of Flax for some time, gave a lecture on the subject from which we will make a few extracts :

"The value of a crop of Flax, standing in a field, is from \$40 to \$60 an acre—the purchaser to pull the Flax. The yield of Flax will vary from 30 cwt. to 40 cwt. per acre; the produce of seed about sixteen bushels. The price of the Flax, after threshing out the seed, \$14 to \$15 per ton.

"SOILS.—The flax crop may be grown with advantage on all moderately cohesive soils, resting on a sound clay subsoil, providing the land is naturally dry, or thoroughly drained; but gravels or very light soils, or lands upon a weak tilly subsoil, are not suited to its growth.

"ROTATION.—Flax will succeed best after Clover sod, or Oat stubble properly prepared on good land; and after a white crop following a green crop, or after potatoes or bare fallow on inferior land.

"PREPARATION OF SOIL.—Deep plowing in early autumn by one plow following another in the same furrow, is necessary to the success of the crop under all circumstances, (except when the land has been previously subsoiled), to break the crust or pan formed below the surface soil, so as to allow the roots of the Flax and the surface water to go freely down; a second furrow will in some cases be necessary in Spring before sowing, but generally running through the soil with the cultivator will be found preferable. Dry lands should be laid into flats, but cold ground ought to be plowed into twelve feet ridges, very slightly raised in the centre; the manure should then be applied, the land well harrowed and rolled, the seed sown on the rolled surface and harrowed in with light seed harrows, taking care to keep the horses as much off the ridges as possible on cold land. It is very desirable that the ground selected for flax should be perfectly clean to begin with.

"MANURE.—Superphosphate of lime, at the rate of four bushels per acre, has proved to be the most suitable manure for the flax crop. Guano raises a soft inferior fibre and injures the crop; and farm-yard manure is not approved of. The crop is found to derive most of its nourishment from the atmosphere and the subsoil.

"SEED.—The best seed is Riga, or the produce of this country, grown from Riga seed the previous year. Great care is necessary in the selection of the seed, so as to get it plump and heavy, and clear of the seeds of weeds. The seed should be sown at the rate of three imperial bushels on good land, and 2½ imperial bushels per acre on inferior land, as soon after the 20th March as the land can be got into proper order, and the weather will permit, but not later than the 20th April. Great care should be taken that the seed is distributed evenly over the surface. It is not desirable to sow grass with the flax crop, as it usually injures the fibre of the flax unless sown after the crop has been weeded. A crop of rape may be taken after flax with great advantage on good land, the same year, and the ground sown down with grass seed if desirable.

"WEEDING.—If clean land has been selected for the crop, and plowed early in the autumn and exposed to the winter frosts, few weeds will generally appear, if the seed used be thoroughly cleaned; but if there be any, they must be carefully pulled. This operation is best done by boys and girls properly superintended. It is necessary that they should always work facing the wind.

"PULLING.—The crop is ready for pulling when the seed in the boles is beginning to change from a green to a pale brown color, and the stalk becomes yellow for about two-thirds of its height from the ground; this is rather a nice point to determine and requires attention, as pulling too soon or allowing the crop to get too ripe are both injurious to the fibre. In pulling, it is necessary to clean the flax from all weeds (if any) to pull it when perfectly dry, to keep the root ends even, and tie it up in small sheaves to be stooked up and stacked when perfectly dry and thoroughly winned, which will be in the course of eight or ten days after pulling."

Some have thought the flax crop an exhausting one, but it is not considered so either by farmers who have cultivated it or by agricultural chemists. Dr. ANDERSON, chemist to the Highland Agricultural Society, states, it is scarcely possible that the flax crop should produce greater exhaustion than a grain crop, certainly not greater than wheat; if a portion of linseed or oil-cake is consumed on the farm, we should have less exhaustion than from a grain crop. Mr. BRISCO and Mr. BARKER have both sown clover and grass seeds with flax and other grain crops—the ground occupied by the flax producing double the catage in the following autumn of that produced where grain crops were sown, while the grass on the ground still remains superior.

Mr. C. BEDELL, Berlin, Mahoning Co., Ohio, writes us his method of raising flax, and the one usually adopted in Northern Ohio. "If on sod ground, plow *very deep* in the spring, as early as frost will allow; harrow well till it is mellow; then sow about three pecks of seed per acre, and drag it lightly. We think three pecks little enough on sod ground, but less might do on corn stubble or fallow. It is less labor, covers the ground from the scorching rays of the sun, and leaves the soil in a better preparation for wheat

than the old plan of summer-fallowing. We get on an average 10 bu. seed of 4 lbs. of dressed flax per acre. The seed sells here for \$1.25 now, and the soil is well cts. per lb. So that a crop yields us \$40.50 per acre of dressed flax. I do not think it prepared, we get 16 bu. per acre of barley or an oat crop." impoverished

SPRING AND SUMMER WORK.

THE intelligent farmer will have all his plans of culture for the succeeding year formed in his mind the autumn beforehand. During the winter he will reflect upon them, and use every means to increase his knowledge; so that he may perform all his operations with facility and economy. He will also make and repair many of his implements, and get everything ready for spring; so that when it comes he can avail himself of the first opportunity to commence operations. The shortness of our *working season* renders this forecast doubly necessary and advantageous.

Barley is a crop which has paid very well for the last few years, and the demand is increasing; so that we may expect good prices for the future. Light, dry, sandy loam, is best adapted for this crop. If the soil is rich, it may be sown after wheat; the earlier the better, providing the soil is dry enough to work well. Two bushels of seed to the acre is usually sown, though we think two and a half, and in some instances, three bushels, is none too much. The land should always be rolled after it is sown. If not in good condition before, it will do to roll when the barley is an inch or two out of the ground. To insure a good crop, it should always be sown the first or second week in April.

Oats should be sown as soon after the barley as possible. They will grow on almost any kind of soil, from a stiff clay to a black muck. The heavy land, however, yields the heaviest weight per bushel. Two to three bushels of seed are generally sown per acre. Sixty bushels per acre is a *good* crop, and is not often though sometimes obtained. There is an opinion, in some districts, that oats are an exhausting crop, and that wheat does not do well after them. We are inclined to think this view erroneous. They should be cradled and *tied up*, as they are apt to shed much if loose. One and a half bushels of oats, half a bushel of barley, and a peck of gray peas, are often sown together per acre in England. The produce is very large, and when ground, forms an excellent food for horses in the spring.

Indian Corn is, of all the cereals, best adapted to this climate; and on the rich lands of the great west, is raised in large quantities with little labor, excepting planting and harvesting. In New York and the eastern States, however, it is absolutely necessary to have the soil well and deeply pulverized, and in many instances well manured, and also hand-hoed twice or thrice, to insure a large crop. In this district it is usually planted about the middle of May. It should be marked *each way*, three feet apart, as it is then planted straighter and is much more easily horse-hoed, plowed, &c. It delights in a light, gravelly loam, and does best on an old meadow or clover ley plowed the previous fall. Barn manure is always gratefully received and handsomely remunerated. Four to six grains are planted in a hill. When the corn is up about an inch it should be dressed with plaster—a good handful to a hill. Its good effect is speedily visible. Wood ashes applied in the same way is often attended with good profit.

Potatoes, till within the last few years, were considered one of the safest crops—never being attacked by insects or injured by disease; but the "potato disease," which has extended to all countries, defies conjecture to account for it, and science to provide a remedy. A well drained, light, black soil, if well manured, is best calculated to produce a heavy crop. But a dry, light, sandy soil, *now* yields the soundest and most palatable

potatoes. Subsoiling for this crop has been attended with great benefit. Good, short bushy is the best for potatoes. A handful of plaster on a hill, as they just break first of May. If planted in rows to be raised. They should be planted about the rows about thirty inches apart and twelve inches between rows kept clean; though planted in the heaviest crop. 300 lbs. of Peruvian guano sown broadcast per acre, and the yield has been attended with very good results on this crop.

Carrots.—The value of this crop, especially as a food for horses, has long been acknowledged, and farmers in various parts of the country are now beginning to grow an acre or so for their own use, satisfied that while they require some extra labor to the oat crop, yet the yield is so very large as to make them much more profitable. They do very well on an old meadow or clover sod well manured, plowed in the spring, well dragged the way of the furrows, till the grass is well covered and there is an inch or two of fine, loose mold. They should be sown in rows one foot apart, as they are then more easily kept clean by hoeing. Three to four pounds of seed are sufficient for an acre. About the middle of April, if the soil is dry and warm, is the best time for sowing. Six hundred bushels per acre is often obtained, and some farmers consider a bushel of carrots equal to a bushel of oats as feed for horses.

Mangel Wurzel.—Though his root contains about 87 per cent. of water, yet more nutritive matter can be obtained per acre from this crop than any other. It is not liable to be injured by insects, and is not so susceptible of injury from drouth as ruta бага and other varieties of turneps. Land for this crop should be well drained, exceedingly rich, and plowed very deep. To insure a good crop of thirty tons per acre bulb and ten tons leaf, the land should be plowed in the fall after wheat; and if subsoiled, so much the better. In the spring, twenty loads of good barn-yard manure should be plowed in, and the land well pulverized by dragging, &c. It may then be marked out in rows two and a half feet apart, and the seed be dropped in the rows at distances of 12 to 14 inches, with 4 or 5 seeds in a hill. We would also earnestly advise that 500 lbs. superphosphate of lime (directions for the manufacture of which from bones, by sulphuric acid, will be found in our January number, page 37,) be applied per acre; this would be about half an ounce to a hill. Its effect, especially in giving the plants a start, is greatly beneficial, and we recommend farmers always to use it if possible. It may be purchased, or manufactured from bones, as best suits convenience. For carrots, beets, parsneps, and mangel wurzel, this substance is a great auxiliary; and for ruta бага and turneps, is the best manure that can possibly be used, costing about \$4 per acre. Mangel wurzel should be sown the first week in June. They should be kept clean by means of a horse-hoe between the rows, and the plants must be singled out, leaving one in a hill. It is necessary to sow several seeds in a hill to insure an even crop. When pulled in the fall, the leaves should be given to milch cows, as they will make them give much more milk. The roots should be stored in the barn or cellar, for winter or early spring feed. They will keep perfectly good till midsummer, if necessary. They are an admirable food for sheep or milch cows, in conjunction with hay or straw.

Ruta Baga, or, as it is called in Britain, the *Swedish turnep*, where there are a number of varieties very extensively grown, does not necessarily require such rich land as the mangel wurzel; neither can such a large crop be grown. They also contain a little more water, and will not keep good so late in the spring. They are nevertheless a highly valuable and profitably cultivated crop; and for sheep, and cattle, and hogs, there is nothing better. The *Skirving's Liverpool Swede* is probably the best kind for this climate, as it is not so liable to run to seed as some others, though there are many other good varieties. In England, one and a half pounds of seed are sown per acre—drilled on ridges two feet apart, and afterwards hoed out twelve inches between each

plant. But as drills have not come into general use, the seed might be sown in the way recommended for mangel wurzel. And be sure you don't forget to use the superphosphate of lime, applied as in the case of mangel wurzel; and then, if the soil is loam well plowed and drained, and the plants are kept clear, you should not be surprized if you write to inform me in 1860.

Clover.—About ten pounds of clean clover seed is usually sown per acre, in April, on the wheat fields. It should always be rolled or harrowed in, if possible. In England, clover is usually sown with the barley crop. Red clover, as found by experience, can not there be grown oftener than once in eight years on the same soil; for if sown once in four years, the land soon becomes "clover sick." Twenty pounds of seed per acre is often sown by good farmers, in hopes of securing a crop. We have seen much heavier crops of clover grown here by the use of plaster, than we ever saw in England under the most favorable conditions of soil and manuring. Clover is often much injured by keeping sheep on it too late in the fall and too early in the spring; and it is better not to let them run on it at all in the fall, if it can be avoided. We would never let land lie with clover more than two years, as after two years there is little extension of root, and the clover is apt to die out and give place to timothy and red top, which we think as exhausting to the soil as wheat, and should never be sown except on low land not well adapted for wheat. It is to the extension of the quantity of land sown with clover and the adoption of root culture, that we confidently look for great improvement in our agriculture and increased profits of the farmers, and, as a consequence, of the entire community.

AGRICULTURAL PROGRESS OF THE UNITED STATES.—The following letter, addressed to the editors of the *National Intelligencer*, Washington, and published in that Journal, contains facts interesting to the American people :

TO THE EDITORS OF THE NATIONAL INTELLIGENCER:—The statistics of Agriculture, so far as they have been published from the Census Office, disclose many instructive facts. To promote the farming interest, and bring some of the most prominent features of this branch of national industry under the eye of legislators and statesmen, I respectfully solicit a small space in your paper to call attention to the progress made by a nation of farmers.

Maize is the most important crop grown in the United States. It is one of the staples of every State and Territory, not excepting Oregon, whose climate is least friendly to this American cereal. The United States census of 1840 makes the corn crop of the year preceding 377,531,875 bushels. The census of 1850 shows that the crop of 1849 was 591,586,053. Increase 214,054,178 bushels. These figures indicate a gain of fifty-seven per cent; while the increase of population was not far from thirty-four per cent. Corn being one of the most profitable crops grown any where, I have studied its increase and decrease in the several States with much interest; but a due respect for the numerous claims upon your columns forbids an extended notice of even the most abundant and remunerating products of our national industry. Allow me, however, to say that New York produced in 1839, 10,972,286 bushels; and in 1849, 17,944,808 bushels. This, for an old State whose rural population increased but little in the last decade, is a large and creditable gain. It is one of the many good fruits of her excellent agricultural societies, known all over this extended Republic, as well as in Europe.

Pennsylvania has advanced her corn culture considerably, although less than New York. Her crop in 1839 was 14,240,022 bushels; in 1849 it was 19,707,702. Gain 5,467,680 bushels. She will do better in the present decade.

Georgia has sustained an agricultural journal for the last nine years, and a flourishing State Society and others some five years. Her corn crop in 1839 was 20,905,122 bushels; in 1849 it was 30,428,540. While Georgia has added to her annual harvest of maize 9,523,418 bu. in ten years, South Carolina has increased hers only 1,549,503 bushels.

Ohio has SEVENTY well-organized agricultural societies, and an efficient Board of Agriculture. Her corn crop in 1839 was 33,668,144 bushels; in 1849, it was 58,922,783. Gain in ten years, 25,254,639 bushels.

These official statistics speak volumes in favor of agricultural societies, and legislative aid for their support. They are composed of practical reading farmers; and I am happy that men of this stamp

are making an earnest effort to organize a national agricultural society. Should they, in its feeble infancy, ask for a little assistance from Congress, it is to be hoped that such small aid as State Legislatures grant to State societies will not be withheld. To say nothing of the large increase in her products of New York, by giving some forty-five societies less than \$8,000 a year, has increased the eighty-two million pounds of fifty per cent. The recent census shows the immense product of over these articles the gain from butter (\$23 pounds.) Cheese 49,785,905 pounds. In the production of united efforts for the promotion of agriculture. In 1839 the corn crop of Virginia was 501 bushels; in 1849 it was only 35,538,582. Gain in ten years but 960,991 bushels.

Unlike the farmers of New York and Ohio, those of Virginia, making amounts to millions of dollars. With a view to correct what I cannot but regard as an erroneous judgment in that noble Commonwealth, I state the fact that from no other State in the Union has opposition been seen or felt to a national agricultural society. Intelligent business men combine their efforts and means to advance commercial, manufacturing, banking, railroad, and educational interests; and why should not farmers unite their wisdom and labors to promote improvements in tillage and husbandry? The science of combinations is as applicable to agriculture as to any other business pursuit whatever. Isolated cultivators of the earth may increase their knowledge and improve their farming operations a very little in the lifetime of a generation, but their progress will be so far exceeded by such as skillfully combine their individual powers that the former will appear to retrograde, not advance.

Agricultural improvement has taken deep root in the soil of Maryland, and her corn and wheat crops have increased faster than her population in the last decade, including the large gain in the city of Baltimore. There is reason to believe that these staples will be doubled, without any increase of tilled land, by the year 1860, if the Legislature of that State foster the plan of its State Society to establish and maintain an agricultural college and experimental farm.

DANIEL LEE.

SHEEP.—I send you an account of my sheep, not thinking to excel many of my brother wool-growers, but with a wish that it may stimulate some others to pay more attention to more judicious breeding and keeping. I had 76 sheep sheared last June, which produced 406 pounds of wool, which sold for 44½ cents per pound. From 44 ewes I raised 47 lambs, which sold for \$1.50 per head. I commenced about the year 1816, with a cross by a full blood merino buck with our native ewes. I have never sold off my flock, but have tried to improve it by selecting good bucks and my best ewes to breed from.

THOMAS REDWAY.—Amber, N. Y.

TO RELIEVE CHOKED CATTLE.—J. Y. DE BAUM, of Spring Valley, N. Y., gives the following method of relieving choked cattle: "Tie the animal's head pretty high; take hold of the tongue with the left hand, and with the right take a leathern trace (the forward end ahead) and run it down fearlessly. The remedy is easy and always at hand, and will perhaps save your animal, while you might lose it in going after a doctor."

BUTTER MAKING.—A subscriber, of Borodino, N. Y., informs us that he has 2 cows, 6 and 7 years old, a cross of Devon, Durham, and Native breeds, which have the last summer given in 7 months 551 lbs. of butter; from May 21 to June 21, 146 lbs.; from May 27 to June 4, 37 lbs. This, he says, is a specimen of the cows in that section.

AGRICULTURAL IMPLEMENTS AT THE GREAT EXHIBITION.

BY P. BARRY, FROM NOTES TAKEN AT THE WORLD'S FAIR.

The old system of *broadcast* sowing of seeds is fast giving way in Great Britain to what is called *drilling*, which is a system of sowing in regular and equi-distant rows. This system is said to have been introduced by the celebrated JETHRO TULL in the early part of the present century, not on account of its own merits, but in order to admit of hoe tillage such as is now practised very extensively in England by horse hoes. For a long time it met with great opposition, and in general, until more recently, met with very little favor. As things advanced, its merits became better understood, and, with implements of certain and efficient execution, it is becoming almost universally adopted. In

this country it is also attracting attention, wheat being now mostly sown with planters or drilling implements. The advantages claimed for it are, that the seed is deposited in the earth with greater exactness in regard to *depth*, regularity, and proportion; economy of seed, in giving it a good hold of the ground in light soils so as to protect it against being drawn out by frosts or loosened by the wind when it has advanced to a heavy top growth; lastly, in admitting of hoe culture, by which the growth of the plants may be stimulated and the growth of weeds prevented. It is perhaps doubtful whether hoeing will ever be applied to growing grain crops in this country to any considerable extent. Where the soil is good, and well prepared previous to sowing, there is little chance for weeds to grow and little need of culture. It may be otherwise; our farmers must consider it. If this system be adopted, the drilling machines or planters must pass over the ground in straight not in zigzag lines, as we generally see over the country. At any rate, this would be a great improvement on our general culture; for nothing can well look more slovenly than curved furrows, fresh drag lines, and young growing crops. I abhor crooked plowing, dragging, and every crooked, careless operation on the land. A man who can not run a straight furrow, or drive his harrow or planter straight, ought to feel ashamed of his awkwardness.

But whether grain crops be ever horse-hoed or not, root crops will; and as their culture is becoming extensive and important, a glance at the most approved English implement may not be uninteresting. The best which I have observed in the exhibition, and one which is offered for sale in all the implement shops, and generally in use, and to which a prize medal has been awarded, is

Garrett's Patent Horse-Hoe.—Fig. 1 is a side view of the machine at work, and fig. 2 gives an end view, showing the manner in which the hoes pass between the rows. It is so constructed that the shafts for the horse can be fixed upon any part of the frame, and the axle-tree being moveable at both ends, it can be expanded or contracted at pleasure to suit all lands and methods of planting. Each hoe works on a lever independent of the others, and this adapts them to all inequalities of the ground, and the hoes can also be set to any width from seven inches to thirty. The hoes are set to any

GARRETT'S PATENT HORSE-HOE.—SIDE VIEW. FIG. 1.

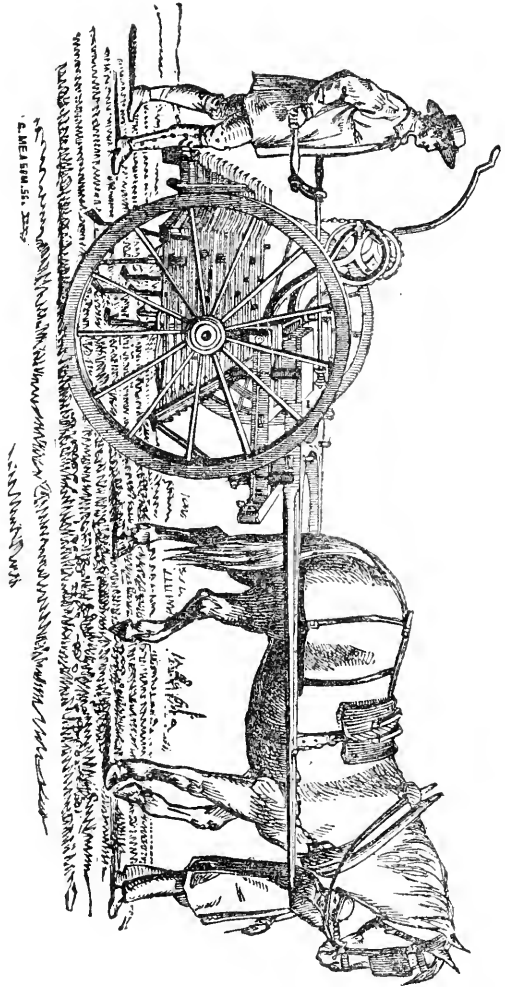

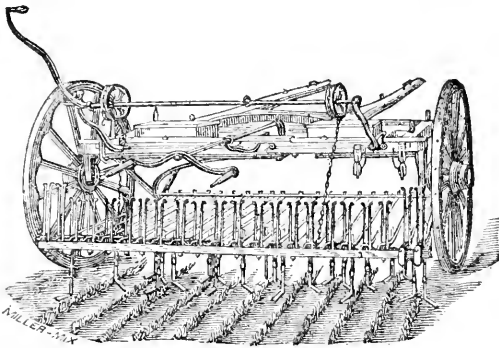

GARRETT'S HORSE-HOE.—END VIEW. Fig. 2.

particular angle by means of the crank which stands up on the left hand side of fig. 2; this is attached by chains to the jointed irons on which the levers and hoes are suspended. There is also a swing steerage to guide it exactly, as shown in fig. 1. One of these which I saw intended for seven rows, weighed 750 lbs., and cost £15. There are other sizes up to eleven rows, costing £20, (\$100.) It is said that a horse, a man, and boy can hoe ten acres per day at a cost of 6d. to 1s. English per acre. The cutting

blades are made of steel, and attached by screw bolts and nuts to the stalks that connect them with the levers. The whole affair is simple, and easily arranged by any workman. *The Patent Drag, Harrow, and Scarifier.*—Here is an implement which our farmers may compare with their cultivators in use for preparing land for wheat and other crops. It strikes me as a most effective contrivance, and considering its weight and power, easily drawn. It moves on four wheels, as will be seen from the cut; and instead of handles like a plow, as ours generally have, it is controlled as to depth of tillage by a lever, seen on the top. The manufacturer says: "The principal novelty in this invention is the

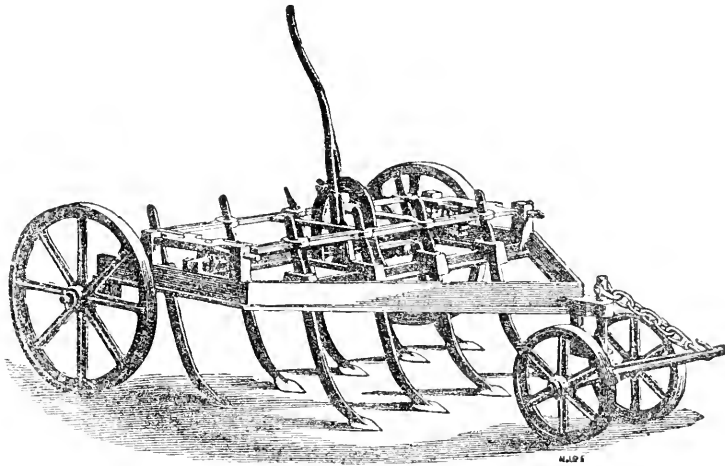

PATENT DRAG, HARROW, AND SCARIFIER. Fig. 3.

frame at the top, suspended about six inches above the lower frame, parallel with which, by means of a lever, it is moved backwards and forwards. This simple and easy movement regulates the depth of the tines or prongs in the soil; and as the implement does not require lifting, (the frame of which is at all times the same height from the ground,) all that is necessary to alter the depth of penetration is, a slight movement of the lever above referred to, which changes the inclination of the tines. It will be found to answer all the purposes of harrowing weeds and rubbish from the most foul lands; most efficient for opening, raising, and pulverising the soil; and as blades of different widths are made to fit the tines, it may be used with great advantage as a skim to take off the couch, &c.

There are some late improvements in its construction, by R. GARRETT & SON, which consist in substituting wrought iron instead of cast iron for the tines, without any extra cost, whereby the liability to breakage is entirely obviated; and in the application of a lever to each side of the scarifier, so that either traveling-wheel may be raised or depressed higher or lower than the other, to suit sloping grounds, and to cause the teeth to penetrate a uniform depth in the land; and this alteration may be effected while the implement is proceeding in its work.

Nett Prices, with one set of Tines or Prongs.—Three feet six inches wide, with five prongs, £7; four feet six inches wide, with seven prongs, £9 10s.; six feet wide, with nine prongs, with side levers, £12; ditto, with wrought iron frame, £18. Points, 8s. per dozen. Blades, 4-inch, 10s.; 6-inch, 11s.; 9-inch, 12s. per dozen."

I annex the prices to show the cost compared with that of the American implements. This machine is somewhat similar to *Hyde's Cultivator*, manufactured in this State.

Improved or Patent Trussed Whiffle-trees.—The difference between these, and those in general use, is fully explained by the annexed drawing, (fig. 4.)

They combine great strength with lightness. The additional strength which the trussing gives, admits of the other part being much lighter; while breaking, under any ordinary circumstances, must be out of the question.

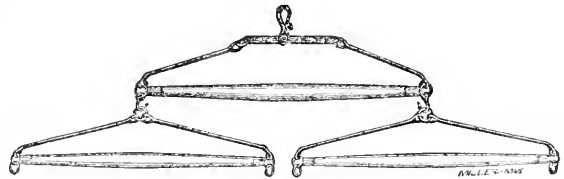

PATENT TRUSSED WHIFFLE-TREES. Fig. 4.

The truss is a light iron rod. This is called in England, "Harding's principle."

Grain Crusher.—This is an implement or machine of great importance. Few people in this country seem to be aware of the advantages of crushing corn or oats before feeding them to horses. Economy alone should induce their general adoption. I know from experience that for a working horse half a bushel of grain crushed is better than a bushel in its whole state. It requires considerable muscular power to properly masticate hard corn or oats, and hence it is that the manure heap shows such a large portion of it entirely whole and fit for growth. I think a good article of this kind at a moderate price would be a great desideratum to farmers. I have heard SINCLAIR'S spoken of, but I do not know how good it is. The annexed cut represents one of the best, simplest, and cheapest, I observed in England. This mill is fixed on a cast iron frame. In the lower part of the frame are two case hardened and slightly grooved rollers; these are adapted for malt, oats, and linseed, which they bruise to any required fineness admirably; the bean roller above acting as a feed all the time, working against a plate, which hangs independently of the frame, and is set up to the roller or drawn back by the regulator screw; this roller is intended for beans, peas, and Indian corn, which it splits in the best manner. When using it for the latter purpose, of course the screws which regulate the lower rollers must be turned back, to separate and throw them out of gear. The hopper falls back upon a hinge, to enable the person using to set the rollers, or see if there is any derangement.

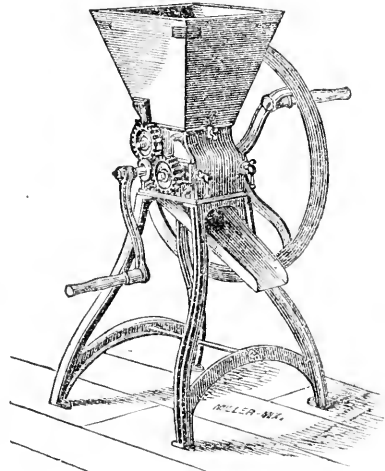

GRAIN CRUSHER. Fig. 5.

Price—£5 15s. 6d.; mill for crushing oats, &c. only, £5 5s.; mill for crushing beans only, £3 to £4; mill for crushing linseed only, £5 to £6. All these mills may be had of a larger size, for horse or steam power, if required.

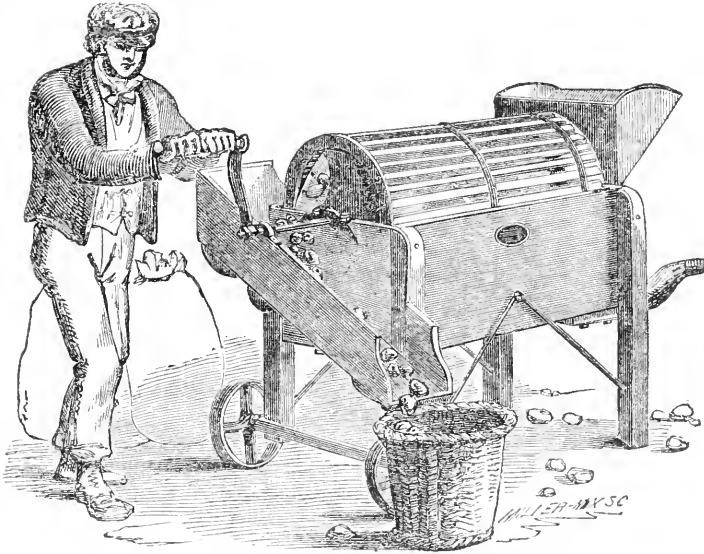

CROSKILL'S ARCHIMEDEAN ROOT-WASHER. Fig. 6.

Croskill's Archimedian Root-washer.—Fig. 6 represents this very useful machine. Where roots are fed to cattle or horses, it is very important that they should be perfectly clean; and where large quantities are consumed, washing in the ordinary way is a tedious and laborious process. In this "Archimedian" washer the roots are delivered into a hopper, and pass thence in an inclined cylinder having two chambers. In the first they are confined and washed by turning the handle in one direction; then by turning the handle round the other way, they pass into the second chamber, which is constructed in a spiral form, along which they pass and drop into a spout outside. This costs in England, \$17.50.

Steam Engines for the Farm.—Steam is the wonderful power of the age. Wonderful in the tremendous force it creates, and in the vast diversity of operations which it is capable of performing at one and the same time with the utmost attainable accuracy. "It can not only in one mill turn a lathe, and in another weave a stocking—in one hammer circular bars of iron, and in another dress a piece of broadcloth; but the same engine can, by the machinery which it drives in the same building, if necessary, hammer, and cut, and file, and turn—can spin, and weave, and dress—can, in fact, take the raw material at one end of the building, and by one single original motion feed itself with coke and water, which itself pumps up, move the machine which takes in the wool, transfer it to the other machines ready for its manufacture, and bring it out broadcloth ready for the tailor. Of such a power as this may not the agriculturist avail himself to carry on his multifarious operations? Why may he not thresh, and plow, and sow, and roll, and harrow, and mow, and stack, by a power which accomplishes for the manufacturer processes far more difficult?" And steam engines really are at this moment used by extensive cultivators to a very considerable extent, and in the great exhibition the large number of engines for farm purposes exhibited, furnish a striking proof that their use has passed beyond the bounds of theory. I have seen several in operation on

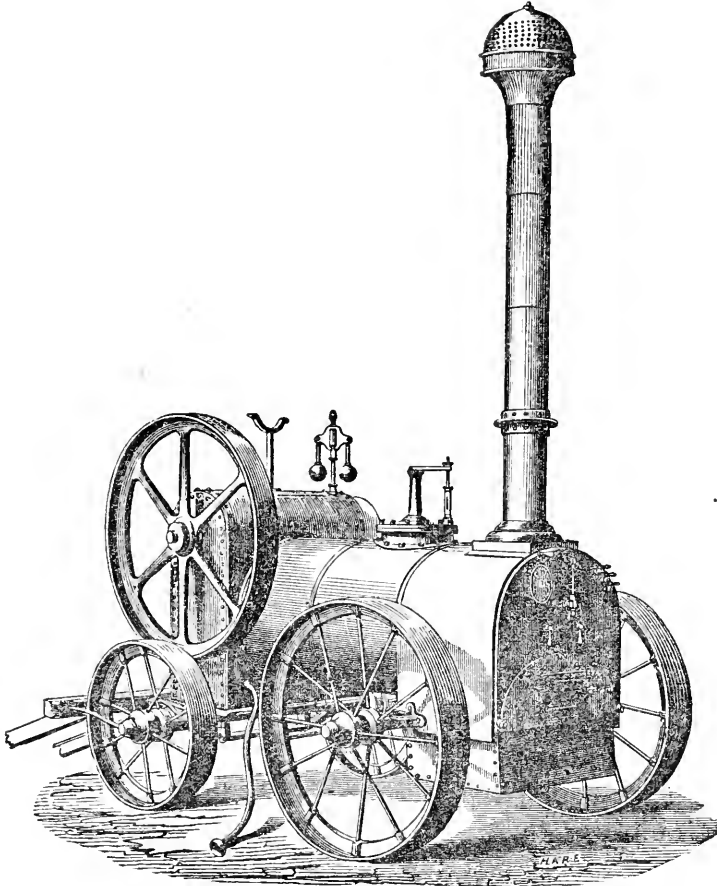

STEAM ENGINE FOR THE FARM. Fig. 7.

farms, and one in an extensive nursery used to pump all the water, cut and crush feed for horses, saw wood, clean seeds, and perform a vast deal of labor. The proprietor said that he had begun to look upon it as one of the most indispensable things about his establishment. Already have some pretty successful attempts been made at plowing; but in this and all other operations on the land, the difficulty to overcome will be to have them move without sinking. But in the barn-yard, if their uses never go beyond, they must be of great service in all large establishments. There is something exceedingly practical and manageable in the appearance of the nice portable engines here exhibited, capable of being drawn by a pair of horses and managed by any laborer after two or three days practice. The usual price for a four-horse power engine on wheels, is \$700 to \$750; of six-horse power, \$800 to \$850. At our last State Fair a *Portable Farm Engine* was exhibited by the manufacturers, HOARD & BRADFORD, of Watertown, N. Y. We learn that the price is, for half-horse power, \$75; one-horse power, \$100; two-horse power, \$160; three-horse power, \$250. The principal objections to the use of steam engines on the farm, are — difficulty of management, liability to explosion, and danger of fire. These objections the manufacturer states he has endeavored to obviate, but how successfully we can not at present say.

Horticultural Department.

CONDUCTED BY P. BARRY.

STRAWBERRIES.

THE strawberry is a fruit that almost every man who has a garden cultivates to some extent. No section of the country is so cold or so warm as to render its successful culture impossible, or even difficult. It is a fruit, too, that requires comparatively a small space—a couple of rods of ground being sufficient for a small family. It also yields immediate returns—the plantation of this season giving a full crop next. It requires good culture and treatment; but this is so simple and so easily given, that it is beyond

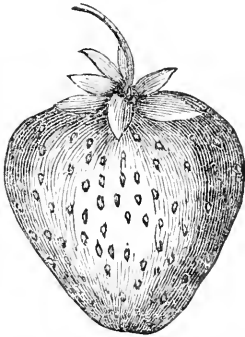

BURR'S NEW PINE. Fig. 1.

no man's reach. Great attention has been given to this fruit within a few years. The value of varieties has been well tested, and multitudes of experiments have been made in its cultivation, so that cultivators have all necessary information within their reach. The horticultural periodicals abound with instructions as to how, and when, and what to plant; but for the benefit of those who may not have had opportunities of seeing these, we will briefly point out the substance of what we conceive to be the proper course for beginners. We will suppose that a strawberry plantation is to be made the ensuing spring.

1st. The ground (if not done last autumn) must be trenched eighteen inches or two feet deep, as soon as it is dry enough to work, turning in a liberal supply of old well decomposed manure—say at least a cart load to a square rod. When

the ground has been trenched thus, it should all be turned over again, so as to pulverize it and mix well all parts of the soil and manure. When this is done, rake off and level the surface, and it will be ready for the plants.

2d. Procure good, strong, well rooted runners, or transplanted runners of last season.

Plant in rows, say three feet apart, the plants eighteen inches apart in the rows, for all the sorts with large foliage; the wood strawberries (*Alpines*;) may be six inches closer.

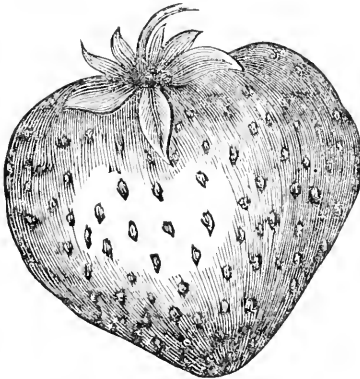

HOVEY'S SEEDLING. Fig. 2.

3d. Keep the ground clean and well hoed as an onion bed all summer, and cut off all runners as fast as they appear, unless wanted to increase the variety, and then only two or three should be allowed on each plant. In the autumn the plants will be luxuriant and large, covering half the ground, and in a fine condition to give a good crop next season. In dry seasons, mulching with a little tan bark, saw-dust, or old manure, will assist their growth very much.

4th. WINTERING.—In many districts no winter protection is needed, but as a general thing a coat of three or four inches deep of straw or leaves, protecting the plants against the thawing and freezing of winter, is found very useful, greatly augmenting the vigor and productiveness of the plantation the following season. We always do it here at Rochester.

5th. TREATMENT OF THE PLANTS DURING THE BEARING SEASON.—Attend to the culture of the soil as on the first season, keeping it clean and friable; keep down runners; and provide for a liberal supply of water in case of drouth. The greatest drawback in strawberry culture, with us, is dry weather at the time of the swelling of the fruit; and if we want them *large*, we must apply water *freely*—let it flow over the plants in torrents three or four times a week. Weak liquid manure, occasionally, will be a great aid in giving size. The result of all our observations at home and abroad, in regard to strawberry culture, is, that great size and heavy crops can only be obtained by a liberal supply of moisture in connection with deep rich soil. We have no space now to quote examples in support of this, but the fact is unquestionable, and it will be well to bear it in mind.

We now come to the selection of varieties, which is a matter of considerable importance. After many trials and experiments here in the vicinity of Rochester, and we ought to add extensive experiments both by amateur and market growers, the following varieties are pretty well settled down upon as the best and most profitable:

Burr's New Pine, (pistillate.) Fig. 1.—A large, light red berry of the finest flavor. Productive and hardy. R. G. PARDEE, Esq., of Palmyra, a first rate amateur grower, exhibited specimens at last year's exhibition of the Genesee Valley Horticultural Society, measuring *four inches* in circumference, and they received the first premium.

Hovey's Seedling, (pistillate.) Fig. 2.—One of the largest and best American varieties—extensively grown and universally admired.

Large Early Scarlet, (hermaphrodite.)—An old, fine variety. Good size, good flavor, and always bears well. One of the best for planting with the pistillate sorts.

Boston Pine, (hermaphrodite.)—A large, fine, productive variety, under high culture, but worthless with bad treatment.

Hudson, (of Cincinnati.)—A most productive variety—the great fruit of the Cincinnati market growers. The Rochester people esteem quite as highly *Burr's Rival Hudson*—a late acid variety, fine for preserving.

To insure the fertilization of the pistillate sorts, one row of the staminate or hermaphrodite varieties should be planted between every four, or in some such proportion.

It is somewhat remarkable that scarcely any foreign varieties prove profitable for our cultivation. In England, and indeed in France, the great strawberry of the day—the one that in every garden and in every market attracts one's attention particularly—is the *British Queen*, (fig. 3.) We never seen such

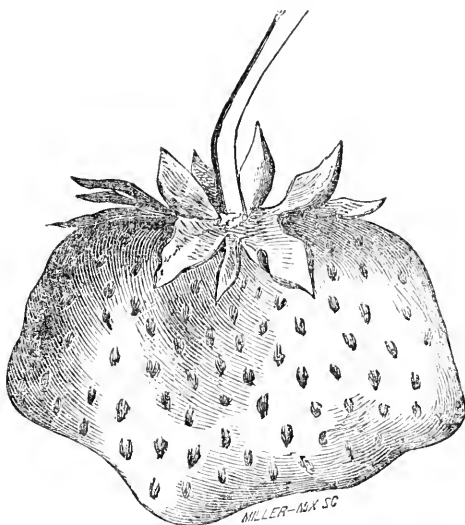

BRITISH QUEEN. Fig. 2.

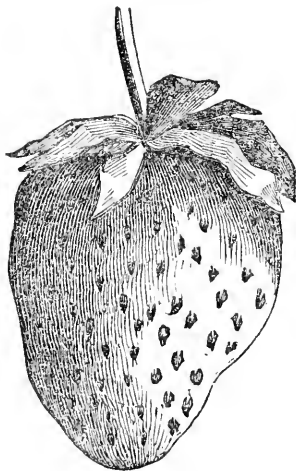

ELTON. Fig. 4.

crops of strawberries anywhere as those of the *British Queen* around London, in the gardens of the market growers. It does not succeed well here; or it has not so far, that we are aware of. A few large and fine berries, say three or four from a plant, may be obtained; but nothing that can be called a crop. It needs more moisture than it gets with us, and we hope to see it yet tested under favorable circumstances. We had the accompanying drawing made from an ordinary specimen picked in a French garden.

Next to the *Queen* stands the *Elton*, (fig. 4.) This succeeds the *Queen*, being later. It is a large, conical, and beautiful berry. We are not aware of its having been successfully grown in this country, but it is worthy of further trial. In Europe no distinctions are made in regard to the "sexual" character of the strawberry, as in this country; all their varieties are staminate or hermaphrodite—that is, have both stamens and pistils perfect.

CULTURE OF THE FUCHSIA.

In our last we promised some hints on the propagation and culture of the Fuchsia, which we now proceed to give. We may first remark that among green-house plants or shrubs it is one of the easiest to propagate or manage.

PROPAGATION.—The usual method is by cuttings. The plant from which we wish to propagate is brought, say in the month of February, into a temperature of 60 deg. It begins immediately to grow, and when the young shoots have attained the length of two or three inches, they are taken off, cut smoothly below a joint, and inserted about an inch into sand, or sandy earth, and if there be a bottom heat of about 70 deg. they will root in a week or ten days; but they will root, without a bottom heat, in a temperature of 60 deg. When rooted, they are potted off into small two or three inch pots, the soil being a mixture of about equal parts of sand, leaf-mold, and decayed turf finely chopped up; add to this a small quantity of old, well-decomposed manure. These must be well mixed. Put plenty of drainage in the bottom of the pot, (small pieces of broken pots). In two weeks these little pots, in a temperature of 60 or 70 deg., will be full of roots, and they may be shifted into others a size larger. When established in these, they may be removed into a cooler place, say 45 to 50 deg., and remain there till planted out, if wanted for that purpose. If disposed to grow up tall and slender, they should be topped to give them strength and roundness.

It should be observed that when Fuchsias are planted out, a cool and rather shaded place should be given them. The *Globosa*, *Globosa major*, and *Serratifolia*, are best for this purpose. When the plants are intended to be kept in pots for the summer decoration of the green-house, or drawing-room window, the shifting must be continued as fast as the pots fill up with roots. The same soil recommended above will do; but as the plants increase in size, it may be richer in manure. They must be freely watered and kept near the glass, stopping to make them branch, and tying up to give them a fine pyramidal shape; syringing frequently over the foliage will do them good. With this treatment, the young spring cuttings will, in July, be two feet high or more, and loaded with flowers till September or October. Old plants should be taken into a temperature of say 45 or 50 deg. in February or March, pruned back nearly to the old wood, potted in good soil such as described above, and shifted and managed in the same way as young ones. The *fulgens*, *corymbiflora*, and their hybrids, must be two years old before a good bloom is obtained. The *Serratifolia* blooms finely in the months of October, November, and December, and if planted out in May or June, potted in September, and housed with other plants, will be a great acquisition at a dull season.

TWO FINE FOREIGN PEARS.

Doyenne Boussock, (Fig. 1.)—This variety has fruited at Boston for several years, and has acquired there the highest reputation. It has borne for two seasons with us, and we have no hesitation in ranking it with the best varieties we cultivate. We are inclined to think that it will become a popular orchard variety, for the tree possesses great vigor and hardiness, grows rapidly both on pear and quince, and bears well. It has been described in nearly all the pomological works of recent date and begins now to attract, what it really merits, considerable attention. *Fruit*—large, obtusely obovate, resembling a very large specimen of *White Doyenne*; it tapers very slightly to the stem, where it is broad; surface sometimes uneven, but generally smooth and regular. *Color*—pale yellow, slightly marked with russet, and tinged, on the sunny side, with brownish red. *Stalk*—short and stout, pretty deeply sunk. *Calyx*—open, pretty large, in a shallow wide basin. *Flesh*—yellowish white, melting and juicy, with a rich, vinous, perfumed flavor. *Tree*—vigorous, and upright in growth. *Wood*—yellowish brown, with light specks. *Leaves*—large, thick, deep green, glossy, and almost flat; they assume, early in autumn, a fine reddish tint, like some of the forest trees. Ripe early in October, and keeps well into November.

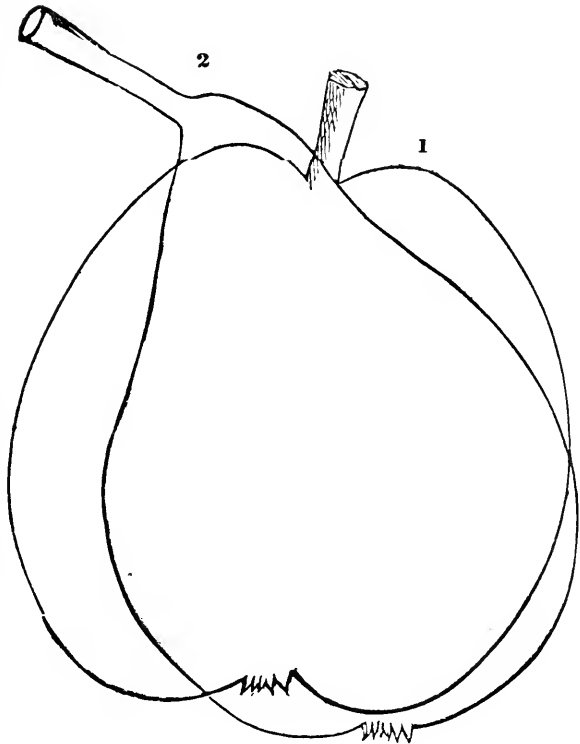

The Duchess of Orleans, (Fig. 2.)—This is another foreign variety proved by successive trials, for a few years past, in various parts of the country, to be of excellent quality. It recommends itself by its beauty, excellence, and productiveness. *Fruit*—large regularly pyramidal, somewhat resembling in form the old English *Jargonelle*. *Color*—pale yellow, slightly marked with light russet and tinged, generally, with light red on the sunny side. *Stem*—over an inch long, rather stout, enlarged on the end attached to the branch. *Calyx*—open, set in the surface, without any depression. *Flesh*—yellowish, melting, buttery, slightly musky—rich and delicious. *Tree*—moderately vigorous, erect; young shoots wavy in habit. *Young wood*—reddish brown, and thickly covered with oblong, gray dots. *Leaves*—of medium size, flat, and of a peculiar yellowish green color. Last season we had finely ripened specimens, picked green, on the 25th Sept. We had others picked later, about the middle of October. It requires to be picked early and ripened in the house. When left to ripen on the tree it loses its flavor and becomes quite insipid.

PERPETUAL ROSES.

THE classes of Roses denominated Perpetuals on account of their blooming at intervals several times during the season, are fast superceding those that bloom but once, unless it be hardy climbers and pillar roses, whose merits are not solely their flowers. Amateurs, who turn to the nurserymen's catalogues and find Remontants, Bourbons, Noisettes, Teas, &c., enumerated, find themselves at a loss in regard to the particular characters and peculiarities (of appearance) of each. We have often been solicited to point out the distinctions, and intended to do so, as well as we could, when we found the following in a French journal and immediately translated it into a sort of English. We must say for it that we have not found in all the ROSE BOOKS we have read, an explanation so concise and satisfactory. We beg those of our readers who cultivate Roses, to note it well and extend their comparisons on the indications given. It is always satisfactory for one to know what they have, and if we have but one Rose in our garden, it will augment its interest, if not its value, to know what class it belongs to.

CHARACTER OF THE REMONTANT OR PERPETUAL ROSES.*

The greater number of the catalogues of nurserymen who devote themselves to Rose culture, do not offer to amateurs any means of judging whether the varieties which they sell belong to the sections in which they are classed. A simple name designates these sections and the varieties which naturally approach each other the nearest are often found the furthest apart, on account of the alphabetical order in which they are inscribed in the merchant's catalogue.

Having been frequently consulted by amateurs to point to them the precise character of each of the sections of Roses, I have endeavored to abridge them in a few words, following the method of botanists, who assemble under a generic name all the species most alike in their common characters.

The seven principal sections are, The Portlands, called Perpetuals; the Hybrid Remontants of Portland; the Hybrid Remontants of the Isle Bourbon; the Bourbon Roses; the Noisette Roses; the Bengals; and the Teas.

Each of the characters which serve to distinguish these sections should be taken in a general sense—separately their value diminishes to a point where it disappears completely. Take for example, that of flowers united in corymbs or panicles (clusters); in certain cases it is insufficient, for the Noisette and Bengals, which generally and under good treatment produce clusters, may produce only feeble shoots terminating in a solitary flower, on account of bad soil or treatment. The same thing, or the reverse, may manifest itself in other selections,† and the great similarity existing between certain subjects in different sections confounds the one with the other. It is then only by much practice, and the aid of the assemblage of many characters, that we are able to distinguish Noisettes from Bengals, and these last from the Teas.

SECTION 1. PERPETUALS, OR PORTLANDS.—The Roses of this section have the thorns very fine, short, and so numerous as to cover almost entirely the branches, to which they give a brownish tint. They have erect shoots, the flower stalks short and stiff, the flowers generally solitary and ovary; seed capsule somewhat long.

EXAMPLES.—*Rose du Roi, Duchesse de Rohan, Julie, Krudner, Bernard, La Favorite, &c.*

SEC. 2. HYBRID REMONTANTS OF PORTLAND.—These have thorns, hard and sharp, variable in strength and length; the shoots erect, and their habit similar to that of the Portlands. They have also a lengthened capsule, and give often one to five or seven flowers which form a bouquet erect and stiff at the summit of the branches. The Four Seasons Rose gives a correct idea of their habit and flowering.

EXAMPLES.—*La Reine, Baron Prevost, Jacques Lafitte, Madam Laffay, Duchesse de Sutherland, Amandine, Louis Bonaparte, Clementine Seringe, Glorie d'Angers, Comte de Montalivet, &c.*

SEC. 3. HYBRID REMONTANTS OF THE ISLE OF BOURBON.—The Roses which compose this section appear to hold a middle or intermediate place between the Portland Remontants and the Bourbons, but more frequently present the aspect of the latter. The leaflets are in general strongly dentated (toothed,) but the round form of the seed capsule distinguishes them from the Portland Hybrids. The disposition of the branches—extended in a confused, irregular manner—give them also a particular aspect.

EXAMPLES.—*Clementine Duval, Comte Bobrinski, Ernestine de Barante, Colonel Foissy, Geant des Batailles, Vicomtesse de Bellevall, &c., &c.*

SEC. 4. BOURBON ROSES (Rosiers Isle Bourbon).—This section comprises the Roses which have the wood very smooth and glossy, the side shoots often short and then terminated by a single flower;

* CARRIERE, formerly Chief Florist at the Museum, Paris, in the *Revue Horticole*.

† It is a very common thing for inexperienced cultivators to form opinions and conclusions from the first feeble growth of a sickly plant. Under such circumstances it is impossible for their true characters to develop themselves, and an opinion based upon such conditions scarcely ever fails to be wrong.—Ed.

but when a branch is developed vigorously, which often happens in many varieties, it produces a longer side shoot terminated by a cluster of flowers, from three to twelve. The thorns are strong, particularly at the base, scattered, and hooked. The leaves are roundish oval, smooth, and of a deep green. The Roses of this section have the seed capsule round, and the branches developed horizontally for the most part.

EXAMPLES.—*Queen of the Bourbons, Madam Desprez, Charles Souchet, Paul Joseph, Souvenir de la Malmaison, Souvenir de 4th May, Remond, Mrs. Bosanquet, &c.*

SEC. 5. NOISETTE ROSES.—These Roses resemble, somewhat, the Teas in their foliage, but are distinguished by a greater vigor; by their shoots being ordinarily very long; smooth bark, although some thorny, especially in some cases; by their branches being terminated by a cluster of flowers, in

EXAMPLES—very large.

SEC. 6. BENGAL, OR *Teas*.—The Roses of this section have a smooth bark—the branches generally but little thorny; the flowers ^{never} or less elongated and toothed; the flowers disposed in clusters or panicles—the slender shoots ^{never} but one flower. The capsule is round; the flowers are almost invariably colored, whilst in the Teas, to which some Roses are often related, the flowers are more frequently white or yellow. There are exceptions—*Tea Burce*, and many others.* The flowers of the Bengal are rarely odorous.

EXAMPLES.—*Bengal Ordinaire* (Daily China), *Cranmoisie superior* (Agrippina), *Eugene Hardy, Beau Carmine du Luxembourg, Augustine Hensan, &c.*

SEC. 7. TEA ROSES.—These Roses have many characters in common with the Bengals—the bark of the shoots very smooth, with few thorns; the leaves are shining, and the flowers, often solitary, at the extremity of the branches, these being so slender that in most cases the flowers are reversed and we see them only on the lower side. The branches generally do not acquire great length, but when the plants are vigorous the branches are longer, stronger, and bear from three to five flowers in a cluster.

EXAMPLES.—*Devoniensis, Safrano, Souvenir d'un Ami, Vicountesse Decazes, Eliza Sawage, Burce, Goubault, Moire, Pactole, &c.*

It will be observed that the peculiarities of the flowers, as to size, form, compactness, &c., which are the really *practical* distinctions, are not taken into account. M. CARRIERE probably supposes them to be too changing in their nature and dependent on circumstances to be a reliable guide of any great consequence. We may add that sections 6 and 7 do not resist our winters in the open ground, and even 4 and 5 require protection in general, and yet these four sections are the most genuine perpetual bloomers.

*The exceptions in this case are almost too numerous to allow the distinction to be of much practical value.—Ed.

SEVERITY OF THE WINTER.—From all parts of the South and West we hear sad reports of injury done to Fruit Trees, by the unusually intense cold of the past winter. The fruit buds on nearly all sorts of fruit trees are killed, and even young trees, very generally. Mr. BATEHAM announces through his paper, the destruction of the buds, and many trees, on his "Pomona farm," and he has reduced the price in consequence. A gentleman writes from Kentucky, that "in consequence of the severity of the weather here on the 21st ult. (January), I have lost all my Peach, Apricot, Nectarine, Cherry, and Plum trees." The destruction will probably be greater than has been experienced in many years. We have examined the buds here closely and frequently, and find, up to this time, only the Peach affected, and even of it, enough of the fruit buds are good to yield a fair crop. A larger number are killed, however, than have ever been before, to our knowledge, at this season (Feb. 18). Trees of all sorts are quite safe; even tender yearlings have not suffered in the least. It fortunately happened that our coolest nights were succeeded by dark days.

HYACINTHS FOR FORCING.—From a large collection of Dutch Hyacinths bloomed in the green-house the past winter, we have voted the following as particularly fine. It should be known that some kinds, first rate in the garden, do not succeed at all in the house. Those of our readers who force Hyacinths in pots or glasses, will do well to make note now for use next autumn. SINGLE—*Baron Thuyt*, dark blue; *Grand Vedette*, light blue; *Grand Vainquerer*, (conqueror), creamy white; *Orondatus*, light blue; *Unique*, violet red; *Mars*, bright red; *Emilius*, dark blue; *Diebits Sabal hamskie*, light rosy red; *Herstelde Vreede*, rosy pink; *Homerus*, flesh color. DOUBLE.—Very few of these force well, but the following are generally good: *Bouquet tendre*, light red; *Lord Wellington*, light blue; *La tour d'Auvergne*, creamy white, large and fine, the best double for forcing.

Ladies' Department.

WE have the pleasure of informing the lovers of flowers that our collection of seeds arrived a few days since, and we are having them carefully put up in packages suitable for distribution, and all applicants will receive them by mail before the 1st of April. Mr. VILMORIN informs us that although the last season was unfavorable for some kinds of flower seeds, and consequently he was able only to send us small quantities into the country. We were gratified at this, as one object we had in view was to distribute much better seed than are usually kept at our seed stores. We want no better evidence than the *three thousand* applications already received afford us, that a love of flowers—a love of the beautiful creations of nature—is rapidly increasing. While the farmer increases his crops of grain, of roots and grass, by a wise system of culture, that enlarges the product without injuring the soil, and the farmer's wife improves the quality of butter and cheese, a few hours by either will not be idly spent in caring for the beautiful flowers of the field, created by infinite wisdom to refine the taste and gladden the heart. During the spring we shall give descriptions of the best annuals, and also directions for cultivation. The present month we give a figure of the *TEN WEEKS STOCK*. The plant grows from one to two feet high, with an erect branching stem, hoary leaves, and long spikes of flowers; the size and richness of these flowers vary greatly in the different varieties, and some of them are very splendid. The species is a native of the South of Europe by the seashore, whence it was introduced in 1731; but the principal varieties have been originated in England and Germany. The German varieties are particularly beautiful.



GERMAN TEN WEEKS STOCK.

For very early flowers, a few plants may be raised in a hot-bed, or in a pot in the house, to be transplanted into the open ground as soon as the weather is sufficiently warm. For sowing in the open ground, the soil should be dug deep and very finely pulverized with the rake. The seed may then be sown in drills, and slightly covered with fine earth. As soon as the plants show the third pair of leaves, if too thick in the bed, they may be carefully transplanted, leaving the plants in the bed about ten inches apart. Transplanting should be done on a damp day. If the plants are large, they should be removed without disturbing the roots. If much exposed to the wind, it may be necessary to tie them to a stake.

Editor's Table.

WE are more than gratified at the evidence we are every day receiving that our efforts to furnish a *good agricultural paper*, and one so cheap as to be within the reach of every farmer, are so well appreciated by those for whose benefit we are laboring. As the large lists of subscribers come in with every mail, requiring all our time to transfer the names to our books, the conviction is thrust upon us that there is "a good time coming," and it is with difficulty that we can suppress a little self-complacency at the thought that we must have done a little to awaken that thirst for knowledge, now becoming so general among American farmers.

We are not yet able to determine what will be our circulation the present year, as "still they come," but it cannot fall far short of 50,000. For this result we are much indebted to the voluntary labors of our friends, and the friends of agricultural improvement, in all parts of the country. We are sending the Farmer now to thousands of Post offices, where only from one to five copies are taken, and where, with a little exertion on the part of our friends, the number might be more than doubled. Will not each of our subscribers at these offices consider himself an agent, and form and forward a Club? Additions can be made to clubs at any time, at the lowest club price. Those who have forwarded clubs of five can increase to eight by forwarding \$1; and those who have sent \$1 for two subscribers can have the number increased to five, by sending another dollar. We authorize money to be sent by mail at our risk, only asking proper care in enclosing and directing. Back numbers can always be furnished.

Our subscribers in Pennsylvania have reason to complain of the late arrival of the February number. This was unavoidable, but we think it will not occur again.

SHEEP FRAUDS.—We continue to receive complaints from the Western States, respecting "eastern Sheep Pedlars palming off common sheep, which have not been shorn for a year or two, for valuable Merinos." But we were surprised to learn, from Mr. W. ANDERSON, Ann Arbor, Mich., and others, that even "some of the gentlemen who eloquently condemn such frauds in the agricultural papers," should themselves be accused of playing the same game. Such conduct is far from honorable or politic, and seriously retards the improvement of our breeds of sheep.

ANNUAL MEETING OF THE N. Y. STATE AG. SOCIETY.—The annual meeting of this Society was held at Albany, on the 21st and 22d of January. The following is a list of officers for the ensuing year:

President—HENRY WAGER, of Oneida.

VICE-PRESIDENTS.

I. JAMES MONROE, of New York.

II. LEWIS G. MORRIS, Westchester.

III. ANTHONY VAN BERGEN, Greene.

IV. WINSLOW C. WATSON, Essex.

V. THEODORE S. FAXTON, Oneida.

VI. OLUCUT C. CHAMBERLIN, Otsego.

VII. CHARLES LEE, Yates.

VIII. JAMES McELWAIN, Wyoming.

Cor. Secretary—B. P. JOHNSON, Albany.

Rec. Secretary—ERASTUS CORNING, JR., Albany.

Members of the Executive Committee—J. T. BLANCHARD and J. A. CORY, Saratoga; J. BUTTERFIELD, Oneida; J. B. BURNETT, Syracuse; and WM. KELLEY, Dutchess.

Mr. DELAFIELD, the President, delivered an address on the subject of the World's Fair, and presented the medals awarded by this Society, to those who had received premiums at the London exhibition.

Prof. NORTON delivered a lecture on the dependence of agriculture upon science for improvement, in which he said, that Agricultural Chemistry was in its infancy; that it was not so easy a matter to become a chemist as some people imagined; that several years of study and practice were necessary to enable any one to analyse his soil and obtain results satisfactory and useful. He was in favor of an Agricultural College, but advised a small beginning; let students and teachers be provided, and the superstructure and other necessaries would follow in their turn. The lecture was well-timed, and calculated to direct public sentiment aright in respect to agricultural improvement.

There was an exhibition of fat stock, dressed meat, grain, &c., which, although only an experiment, and the weather very unfavorable, was better than could be expected, and such as to warrant a more liberal list of premiums for the coming year.

At a meeting of the Executive Committee on the 23d, it was resolved that the Fair for this year be held at Utica, on the 7th, 8th, 9th, and 10th of September, if the requirements of the Committee are complied with, which we suppose means that the citizens pay all the expenses of the Fair, except the premiums.

Inquiries and Answers.

HOT-BEDS.—We cannot speak favorably of our success with cloth as a substitute for glass in making hot-beds.

TOBACCO SEED.—We refer those who have inquired for Tobacco Seed to the advertisement of J. RAPALJE & Co., in this number.

"BROMER'S MANURE."—R. T. P., PUNXSATOWNY, Pa. —We know nothing of this "*prepared manure*," and would advise no one to purchase such articles without the composition is certified to, so that a correct estimate may be made of its value.

THE FARMER—WHEAT, POTATOES, MANURE, AND FOWLS.—I have been a subscriber to the Farmer nearly a year, and have been delighted with the reading matter it contains. Before we took it, my wife had been a subscriber to a Ladies' Magazine at four times the price, but she now says she prefers the Farmer, as the most interesting and instructive. She is a lover of flowers and gardening, and, by-the-by, wishes you to take her name as a candidate for some of the choice flower seeds the coming season.

I have just now been perusing the last number of the Farmer by a cheerful fire, whilst the rain is fertilizing the parched ground without, and seeing that you notice letters of inquiry on different subjects relating to farming, gardening, horticulture, &c., I feel inclined to submit a few questions to you, which if you deem worthy of notice, of course I shall feel flattered.

I have, for the first time in my life, come in possession of a house and lot of my own. The lot contains four acres; the soil is rather light and has not been improved much; it is of a sandy, loamy nature, the stone in part flint, and a mixture of what is here called the soap stone and iron stone. Now, as I am rather inexperienced in farming or gardening, or anything of the kind, I would like to get some instruction through your paper. There is a thin clover sod on one-half of it, which I had intended to plow under for wheat, but being busy building, and the season extremely dry, I delayed till too late. My potato crop last season was small, though what I had were very good, being very dry and mealy. I think the soil is well adapted to potatoes, and I think I should prefer cultivating them, could I produce two or three hundred bushels to the acre, as you say may be done. I can have access to some ashes, some barnyard manure, and plenty of lime four miles distant, at 8½ cents per bushel.

I would like, if I knew how to conduct and manage a small henyry, to have one if it did not interfere too much with my little field. Could you give me some information as to their probable profit, the cheapest convenient mode of constructing the arrangements, and the best common kind of layers. Can any kind of hens be made to lay all seasons—winter as well as summer? What is the best plan of managing to effect this?

But I presume I have now given you enough questions for once. I have given so many, believing that information may be given through your widely circulated paper, either by you, or some of your correspondents, which will be instructive and entertaining not only to me, but to many of your subscribers in Pennsylvania. WARREN STEACY.—*Bart, Pa., 1851.*

Potatoes are a better crop than wheat to grow by one who has but four acres of land, all told. Use a little lime and a *great* quantity of ashes per acre, well incorporated with the soil, if you would grow a large crop of tubers. If the land lacks organic matter, apply leaf mould from the woods. A little well rotted manure may be added to bring them up to a high state of productiveness.

You might keep a few fowls with profit, but

large numbers of fowls cannot be kept together without great care. They become diseased and die. Fowls want plenty of room, and a chance at the fresh earth. Although many agricultural editors ridicule the large breeds, we have no hesitation in saying that the Shanghaes are the best layers in the country. They are yet costly, and probably cannot now be procured for less than \$5 per pair, which is too much to pay except for a pair or two to breed from. They will be cheap in a year or two. It is not natural for any birds to lay during the whole year. Yet much can be done by keeping them in a very warm house, and feeding fresh meat and pounded oyster shells, or lime and bones. A box of ashes, or sand, is quite a luxury, and necessary to their cleanliness.

CARTS.—A correspondent says: "I am much pleased with the plan you offer, so far as I understand it, and wish to get up a cart from the drawing, but find myself at a loss to understand one or two important parts. You say the body sets flat on the axle, and the shafts are attached to the bottom of the body by bent iron plates. Now it appears from the drawing, that the shafts are attached at the extreme front part of the bottom, which I think cannot be the case. How far from the front end are the shafts attached? (1)—What is the shape of the bent irons by which they are fastened? (2) How high are the wheels, and what is the width of the tire? (3) JAMES GARDNER.—*Hollidaysburg, Pa.*

(1) The shafts are attached to the bottom, by bent iron plates, near the axle, and it tips on the bolts which connect the shafts and body there. The usual way is to have shafts and frame attached to the axle, the body to sit on bolsters to bring it level, and to tip on the axle.

(2) Flat, and of sufficient width to correspond with the timbers or wood work.

(3) As a general thing, four and a half feet is the proper height for wheels, and four inches width of tire for the land. It cannot all be made plain, without skeleton drawings, but any good waggon maker who understands the *principles* can adapt the parts to each other.

YELLOW SPOTS IN WHEAT.—I write for the purpose of obtaining information through the columns of your valuable paper, as to the cause of the appearance of yellow spots in wheat. These spots are not generally seen until the warm weather of spring, when all at once different parts of the field will begin to wear a yellow and sickly appearance, and become stunted in growth. Sometimes these spots are not observed at harvest. At other times the disease is nearly fatal. My own opinion is that it is caused by some insect, but what kind of one (if insect it is) is a question. It is not the work of the Hessian fly, neither is it caused by wire worms; nor is it owing to a poverty of the soil, for manuring does not prevent it; it is not owing to a lack of potash, for I observe that the wheat is affected where I burned a log heap before sowing. Any information on this subject would greatly oblige A SUBSCRIBER.—*Onicy, N. Y.*

Many believe that the larvæ of the wheat fly (*cecidomyia tritici*, not Hessian fly,) are in seed wheat when sown, and that the development of the insect in the young plant in the spring, occasions the injury of which our correspondent speaks. Mr. W. P. KINZER, an intelligent observer in Lan.

eastern Co., Pa., says: "In May, young insects are easily discerned with the naked eye, (having grown from the nits deposited in the groove of the wheat grain,) lodged in the bulb of the plant between the radicles and culm, or plumule, in the pupæ state, which soon after forms chrysalis, after which, being now in a perfect state, the young fly by means of its ovi positor, escapes through the bulb of the plant, nearly even with the surface of the ground.—(See Albany Cultivator for October, 1836.)

German entomologists enumerate over a thousand insects that prey upon cereals, at the head of which is *tricum*, (wheat). We are by no means sure that Mr. KINZER is entirely correct in his observations. We have, too, hatched out a fly from a seed of wheat, November 8th; and we are not certain where the mature insects, so common in the wheat of Maryland and Virginia, spend their winters after their maturity.

BONE DUST AND SUPERPHOSPHATE OF LIME.—Will you be pleased to inform me, and others interested, through your excellent paper, whether Bone Dust and Superphosphate of Lime are as valuable, as manure, for carrots as for turneps. JOHN W. BAILEY.—*Plattsburgh, N. Y.*

We have never used Superphosphate of Lime for carrots, but think it will be a very good auxiliary of farm-yard dung, sown broadcast at the time of sowing the seed. We intend using it this summer, and hope our friend will do the same and let us have the result. Leave a few rows undressed, by way of comparison, &c.

THE GOPHER.—Your correspondent E. M. B., asks information relative to the habits of the "gopher." Could my young fruit trees and garden vegetables talk, they would tell him that its habits are bad enough. They do their mischief principally during the night, and always under ground, rendering it very difficult to capture them. Many persons call our prairie or ground squirrel by the name of gopher. The gopher always works under ground, while the prairie squirrel (which much resembles your eastern chipmunk) does its mischief upon the surface and in the daytime, and, compared with the former, are inoffensive. The gophers became so numerous and troublesome that I laid aside all business, and appropriated my services for a time to their especial benefit. Having selected a quantity of potatoes the size of a walnut, I put a little strychnine in each, filled my coat pockets, took my spade, and started the rounds, opening every fresh mound until I found their road or hole, into which I rolled a potato. The next morning, armed and equipped as before, I paid them another visit, and found that the holes had all been closed up. I again opened them, together with all new mounds, and as before introduced my poisoned potato. I perseveringly pursued this course for four or five days, since which I have not discovered a sign of one on my premises. This course has been pursued

by a correspondent of the *Prairie Farmer*, with like success.

A few years since, I was much troubled by rabbits girdling my fruit trees. I cut thin pieces from the sides or base of scrub apples, sprinkled a little strychnine on the fresh side, and at night placed them in the places frequented by my troublesome visitors; and such was the unerring certainty with which it laid them out, that a neighboring nurseryman tried it, and gathered half a dozen rabbits at a time, the result of a single night's operation.

Could I have known of this earlier, it would have saved me many dollars and much perplexity; and if it will be of service to any of your numerous readers, use it. WM. L. LARNED.—*St. Anthony, Minnesota Territory.*

GARGET IN COWS.—Will you please to inform CARLTON GRAVES, through the *Genesee Farmer*, that the garget or pokeweed root operates like a charm, and is all that can be desired as a remedy for the garget in cows, when in a mild form. I have given green root the size and length of a man's finger, mashed fine, as a dose several times. A piece of the root put in the dewlap will have the same effect if the case is not violent. I would recommend that he procure COLE'S book on Diseases of Domestic Animals. S. B.—*Susq. Co., Pa.*

JOSEPH TICKNER, of Harmony, N. Y., gives the result of forty years' experience as follows:

I noticed, in your October number, a question from a brother farmer, desiring information in regard to the treatment of garget in cows. Being in possession of the necessary information, I feel bound to make it known for the benefit of your readers. During above forty years' experience, in which time I have cured many of my own as well as my neighbour's cows, I have never known it to fail of curing in a single instance. The remedy is simply this: Take skokeweed and cut up your double-handful fine; mix with meal and feed you cow. One mess will generally effect a cure; if not, try a second, which I never knew to fail.

TO PREVENT HOGS FROM ROOTING.—I was much amused in reading the inquiry in the January number of your paper headed "To prevent Hogs rooting," and was particularly amused by the manner suggested of performing the operation. In the first place, if H. JENNINGS had taken the trouble to have whittled a grunter's nose down, as he should have done, he would have found the tendons spoken of that support the end of the nose and are attached to the top of it. These diverge towards the eyes, near where the muscles are situated which give the power. These tendons are consequently several inches in length, and by severing them at any point between the muscle and end of the nose the object will be effected. The point of a pen-knife is the proper instrument to be used, and there is no necessity of cutting across the nose to accomplish this, as it would require quite a deep gash through the integuments of the nose before the tendons would be cut off by such means. J. H.—*Big Stream Point, Yates Co., N. Y.*

PUMPKINS AS FOOD FOR STOCK.—I have often seen root crops recommended very highly for feeding to stock during winter, and I believe in using something of the kind; but it seems to me that the culture of roots must be somewhat tedious. Now, I would ask, cannot something which is more easily cultivated be substituted for roots? I think that pumpkins would answer the purpose, and that an equal quantity could be raised at much less cost. But do they contain as much nutriment in a given weight as the roots generally recommended? or how much are they inferior to Indian corn? Can they be saved through the winter? These are questions which I am unable to answer. It would be conferring a favor on me, and probably on many others, if you or some of your numerous correspondents would answer them through the Farmer, and tell us all about the proper soil, mode of culture, keeping, &c., &c. MARCUS M. MOSER.—*Flint Rock, Catawba Co., N. C.*

BEES ROT.—Last spring I purchased two swarms of bees, both large and healthy. The season being quite cold and wet, they cast off but one swarm. This fall I found the swarm which swarmed in the summer, to be badly affected with the "bee rot," a disease quite common in this section for a few years past. It appears that the young bees die while in the larva state, and the bees refuse to uncap the cells and rid themselves of the evil. Their decomposition soon causes an effluvia as poisonous to the parent hive as it is disagreeable to the smell. The cause can not lie in the dampness of the season, for we have had it for several seasons when very dry and warm; neither can it lie in the peculiar kind of honey gathered, for a few years since the disease was unknown. Will some of your readers interested in bee-culture state, in your columns, their opinion of the cause, and if possible, suggest a remedy. D. G. FORT.—*Apulia, N. Y.*

HORTICULTURAL

(M. B. B., Fredricka, Del.) "**BURNING STRAWBERRY VINES.**"—We do not practice nor approve of the operation.

SEA KALE.—Take a piece of good garden soil, trench eighteen inches to two feet deep, turning in about a couple of cart loads of manure and half a bushel of salt to the square rod; plant the roots in rows two feet apart, and about twelve to fifteen inches apart in the rows. Plants can be had at the nurseries at \$1.00 or \$2.00 per dozen, or may be grown from seed to be obtained at any of the seed stores. To be fit for use it must be *blanched*, either by covering the plants in spring, as it begins to grow, with suitable pots or with light sandy earth. It may also be forced by putting warm stable manure around it.

RHUBARB, OR PIE PLANT.—For this, trench the soil deep and manure heavily. Any good garden soil treated thus will be suitable. Plants should be set three feet apart each way. To be sure of having a certain variety, you must obtain *roots*, but very good sorts are sometimes produced from *seeds*. A great deal depends upon the treatment, *good deep soil and abundance of manure* being the chief requisites.

(L. B., Out West.) *Six best Summer Apples.*—Red Astracan, Early Harvest, Early Strawberry, Large Sweet Bough, Early Joe, and Summer Rose. *Six best Fall Apples.*—Fall Pippin, Graevenstein, Pomme Royal, Jersey Sweet, Porter, and

St. Lawrence. *Six best Winter Apples.*—Baldwin, Swaar, Esopus Spitzenburg, Northern Spy, Tallman Sweeting, and Rhode Island Greening.—*Scions* can be sent by mail, if the quantity be small, but express companies are now so numerous that you can procure them easily and *safely* through them. You will find nurserymen's advertisements in the Farmer. We cannot recommend any one in particular.

(W. B., Blenheim.) Peaches are rarely grafted and do not succeed well. They can be budded on the plum or almond as well as on the peach.

(A. W., Galesburg, Ill.) Half decayed saw dust is a valuable ingredient in manure, and especially stiff soils. We have seen plants growing well in it alone. We have no experience in the application of coal ashes to fruit trees in a *special* way. Has any of our readers? The art of *feeding* fruit trees to make them proof against blight, is unknown—a great subject for future investigations. We know, from experience, that a *dry and moderately fertile soil* is most conducive to their general well being.

(A Subscriber, Buffalo.) Your soil being an "old brick yard" will not be suitable for the peach, which requires a dry friable loam. The apple, pear, and plum, may do well on it, provided it be properly prepared by frequent plowings, and by turning in light substances, such as leaf-mold from the woods, swamp muck, saw-dust, if convenient, and stable manure; sand would also improve it, by increasing its porosity. For select varieties refer to a nurseryman's catalogue, or to back numbers of the Farmer.

(J. P., Fredonia.) The preparation of manure for hot-beds consists in turning it over repeatedly, in order that it may be uniformly decomposed and not *burnt*, as heaps generally are when left to themselves. After being turned several times, the first violent heat passes off and then decomposition going on gradually gives out a more temperate heat and it is fit for the bed.

(Ida, Haviland Hollow.) Petunias, Verbenas, Salvias, Heliotropes, Cupbeans, Lantanas, and Scarlet Pelargoniums, will answer your purpose—blooming all summer. Among hardy Climbing Roses, *Queen of the Prairies* and *Baltimore Belle* are two of the best. The new Phloxes are worthy your attention. *Six fine cheap Dahlias.*—Queen of the East, Purple Standard, Striata Perfecta, Triomph de Magdeburg, Stern von Miedling, and Indispensable White—all distinct and good.

A REQUEST TO FRUIT GROWERS!—MR. A. PORTER, Nettle Lake, Ohio, has an orchard of apple trees to graft and desires us to request fruit growers,

who may have them to spare, to send him grafts of choice kinds. He believes there are many who will do it with pleasure, and we trust, having done our duty, he will not be disappointed.

(A. J. H., Newfane.) **GRAFTING QUINCES ON THORNS.**—It will do very well if the thorns be not too large, say about an inch in diameter, and graft near the ground. It would be better to graft where they stand and remove after one year's growth of graft.

(J. M. B., Adams, Jeff. Co., N. Y.) **STOCKS FOR THE PEACH.**—The best stock for the peach in your cold "Black River" country, will be the plum, and the native species that grows quite late is the best, working well after the peach buds are mature. Bud near the ground.

(F. W. L.) **DWARF ORNAMENTAL TREES.**—There are certain kinds of ornamental evergreen trees that may be kept of small size by shearing or pruning them annually. Such are the Arbor Vite, all the species and varieties; the Red Cedar; the Hemlock; and the White Cedar. The Norwegian Fir also bears shearing well and may be kept of small size where fancy or circumstances require it. The better way, however, is, in the case of ornamental trees, to select, for small places, species that do not attain large size—rather *shrubs* than trees. Dwarfing by the use of certain stocks, as in fruit trees, is not practised, and would probably be of little practical advantage.

DWARF FRUIT TREES.—You have an excellent article in your last number, on the subject of Dwarf Fruit Trees, but as they are but little known in this section, and as we are ignorant of their comparative value, you will much oblige some of us who are about to plant trees next spring, by answering the following questions in your March number. What is the longevity of the pear upon quince? (1) What is about its maximum of fruit when full grown? (2) Which will produce the most fruit during the first ten years, the dwarf for the standard, supposing both of a kind? and which during the first fifteen years? (3) We are aware that a variety of circumstances would qualify the answers; but without supposing you can be exactly definite, we thought you would, from much experience and observation, be able to give such an answer as will settle the question of comparative value. C. W.—*Pleasantville.*

(1) There is so much depending upon circumstances that we can give no very definite answer. One variety under favorable circumstances might endure fifty years or more, whilst others might endure half that time. If varieties be selected that are well known to flourish on the quince, and they are planted on suitable soil, and be afterwards properly taken care of, they will, at any rate, endure an ordinary life time in a healthy and productive state.

(2) We know trees that are not yet full grown, and produce annually a barrel of fruit. But we think that few varieties would come up to this, quite.

(3) During the first ten or fifteen years, those on the quince will unquestionably yield the largest amount, because they will bear from the third year, whereas those on the pear will not commence bearing to any amount before the eighth or tenth year. It is after the fifteenth year, or we might say after the twentieth year, that standard pear trees on pear stocks yield large returns. For a solid, permanent, *investment* in pear culture, plant standard trees on pear stocks, but for immediate returns, say for the first ten or fifteen years, plant those on quince.

CRANBERRY CULTURE.—I should like to inquire, through your paper, respecting the cultivation of the Cranberry plant—where they can be obtained; what soil is necessary for their growth; the probable expense of getting them; what time is best for transplanting; and how they are to be treated after they are transplanted? Your answer to the above questions will greatly oblige several of your subscribers. C. E. CLARK.—*Danville, N. Y.*

The attempt to cultivate Cranberries on high land, we believe, has been a failure. They are natives of the swamps, and we think they will thrive only on mucky land. We have had no experience in their culture.

Fruit Scions for 1852.

THE subscriber will furnish Scions for this season's grafting, of the celebrated fruits of Western New York:

APPLE.

R. Stone Pippin,
Summer Rose,
Pambo,
Esopus Spitzenburg,
Yellow Bellflower,
Roxbury Russett,
Early Harvest,
Early Strawberry,
Autumn Strawberry,
Early Joe,
Full Pippin,
Holland Pippin,
White Island Greening,
Tulman Sweeting,
Green Sweeting,
Porter,

PEARS.

Firgaltien,
Swickel,
Sacall's Orange, or Onondaga,*
and most of the Foreign varieties.

Apple Scions \$1.00 per 100, and Pear Scions Three Shillings per dozen. They will be carefully packed and sent by Express or by Mail. A discount on apple scions will be made to nurserymen.

Early orders are requested, to insure a supply. Address me (post-paid) at Rochester, Monroe Co., New York.

JAMES H. WATTS.

N. B.—In all cases where it is possible, I will send samples of the "Northern Spy" apple. Reference can be made to Mr. Vick, of the "Farmer."
Rochester, Jan., 1852.

Rochester Commercial Nurseries.

BISSELL & HOOKER offer for sale, in large or small quantities, a large stock of Fruit Trees, which they believe are inferior to none in health, beauty, or accuracy—among which are Apple, Pear, Peach, and Cherry Standards; Dwarf Pears on imported Quince stocks; Grape Vines, native and foreign; Raspberries, Strawberries, Currants, Gooseberries—strong, imported plants, at low rates. Osage Orange hedge plants. Ornamental Trees, Evergreens, Roses, &c. Green-house and Bedding-out Plants, of superior quality. Double Dahlias, Calceolarias, &c.—all of which we are confident will give satisfaction.

A general Catalogue will be sent gratis to all post-paid applicants.

NEW AND FINE SHRUBS AND PLANTS.

ELLWANGER & BARRY, Proprietors of the Mount Hope Nurseries, Rochester, N. Y., solicit the attention of those interested in Ornamental Plants to their large stock of rare and beautiful Shrubs and Plants, among which are the following:

HARDY SHRUBS.

Deutzia Scabra, or Garland Deutzia, a fine white flowering shrub.

Forsythia Viridissima.

Ribes Gordoni—Gordon's Currant—yellow and crimson, very fine.

Spiraea Prunifolia flore pleno—small, double, white flowers in great profusion; fine dense habit.

Spiraea Lanceolata, or Revesti, one of the finest of the genus.

Spiraea Chamædrifolia, *Niconderti*, *Lindleyana*, *Japonica*, and twenty others.

Syringa (*Philadelphia*) *Pubescons*, *Zepherii*, *Cordata*, *Double*, *Columbiana*, and others, all fine.

Lonicera Ledebourii—a fine Californian shrub.

Tamarix, *Africana*, *Germanica*, *Gallica*, and *Lebanotica*.

Viburnum Lantanoideis, a beautiful shrub.

Wigelia Bosca—the finest hardy shrub, lately introduced from China.

The above excellent things can be furnished in quantities, at low prices.

SELECT GREEN-HOUSE AND BEDDING PLANTS.

FUCHSIAS.—Our collection is one of the best in America. The most distinct and best varieties yet introduced and quite rare, such as *Pearl of England*, *Fair Rosamond*, *Serratifolia*, *Serratifolia multiflora*, *Fulgens Corymbiflora*, *Corymbiflora Alba*, *Magnificent*, *President*, *President Torch*, *Spectabilis*, &c., are propagated largely.

VERBENAS.—A collection of fifty varieties, comprising everything fine introduced to this time.

HELIOTROPES.—*Souvenir de Liege*, *Corymbosum*, and some new varieties just received and to be announced hereafter.

PLUMBAGO LARPEŒTE.

CYPREAS.—*Platycentra*, *Stringulosa*, and others. The first is one of the finest bedding plants.

LANTANAS.—*Ewingi*, the fine new Cincinnati variety, rose and straw color; *Mutabilis Major*, and several others.

BOUVARDIAS.—*Triphylla*, and others.

BUTYLONS.

SALYIAS.—*Splendens Major*, *Oppositifolia*, *Aurea*, and others—superb plants for masses.

FADIANA IMBERICATA.

HYDRANGEAS.—*Hortensis*, *Japonica*, *Cordata*, &c.

Buddleia LINDLEYANA—a fine shrubby plant with large clusters of purplish lilac flowers; blooms in the autumn.

HABROTHAMNES ELEGANS—a superb plant, half shrubby, with large clusters of showy crimson flowers; blooms equally well in the open ground in autumn, and in the house in winter.

PETUNIAS.—A large collection, embracing all distinct and good sorts.

LOBELIA FULGENS INSIGNIS, **LOBELIA FULGENS ALBA**—flowers of dazzling beauty—both new.

VERONICA LINDLEYANA—a charming autumn flowering plant; long elegant spikes of pale (nearly white) blossoms. *Veronica Andersoni*—finest of all—new.

TREE VIOLETS—white and purple.

CHEYSANTHEMUMS.—A fine collection of the novel and beautiful pom-pone or dwarf varieties.

DAHLIAS.—A superb collection, including the English and French prize sorts of 1851—all at very low rates.

CINERARIAS.—A fine collection of new and beautiful sorts, including *Magnificent*, *Atilla*, *Dread Copperfield*, *Wellington*, *Beauty of Newington*, &c., &c.

All the above articles furnished in large or small quantities, at low rates, and packed so as to go any distance with safety.

Priced Catalogues of Dahlias, &c. &c., ready 1st of March. March 1, 1852.

Seneca Lake Highland Nurseries,

CATHARINE, CHEMUNG CO., N. Y., Near Havana Depot, N. Y. & E. B. Road. A complete assortment of Nursery articles, wholesale and retail. Great inducements to Eastern, Southern, and Western dealers. Packages amounting to \$10 delivered at New York and Dunkirk, or any intermediate station on the Erie Railroad, free from charges to the purchaser. Price and Descriptive Catalogues furnished gratis, by mail. E. C. FROST.

March 1, 1852.—3-1*

HIGHLAND NURSERIES, NEWBURGH, N. Y.

A. SAUL & CO have the pleasure to announce to their patrons, and the public in general, that their stock of Fruit and Ornamental Trees, which they offer for sale the coming spring, is of the very best quality, and embraces everything in their line that can be procured in the trade.

Dealers and planters of trees on a large scale, will be treated with on liberal terms as can be done by any establishment of reputation in the country. They flatter themselves that for correctness of nomenclature of fruits, (which is a serious consideration to planters) that their stock is as nearly perfect as it possibly can be, having been all propagated on their own grounds, from undoubted sources, under the personal supervision of Mr. Saul. They have propagated in large quantities all the leading standard varieties, which are proved to be best adapted for general cultivation, especially those recommended by the American Pomological Congress at its several sessions, as well as all novelties of recent introduction, and kinds particularly suited to certain localities, and sections of the Union and Canada.

Their stock of Pear Trees is the largest they have ever had to offer for sale, and among the largest in the country, and consists of over 50,000 saleable trees.

The stock of Apple Trees is also very large, as well as Plums, Cherries, Apricots, Peaches, Quinces and Nectarines. Also, Grape Vines, Gooseberries, Currants, Raspberries, Strawberries, &c., &c.

Pears on Quince, Cherry on Mahaleb, and Apple on Paradise stocks, for pyramids and dwarfs for garden culture, and of which there is a choice assortment of the kinds which succeed best on those stocks.

DECIDUOUS AND EVERGREEN ORNAMENTAL TREES AND SHRUBS.

Embracing all the known kinds suitable for street planting, of *extra size*; also, the more rare and select, as well as all the well known kinds suitable for Arbor-trees, Lawn and Door-yard planting, &c., including Weeping Trees, Vines, Garden and Climbing Roses in great variety. Hybrid Perpetuals, Hybrid China, Hybrid Bourbons, Hybrid Damasks, Hybrid Provence, and Bourbon, Tea, China and Noisette, and Prairie, and other Climbing Roses.

A large quantity of Arbor Vitæ for Screens, Buckthorn, Osage Orange, and other hedge plants.

The above will be sold on as liberal terms as similar stock can be purchased elsewhere. For further particulars see catalogues, a new edition of which is just issued, and will be forwarded to all post-paid applicants by mail. A liberal discount will be made to purchasers who buy to sell again, and extensive planters on their own account.

P. S.—Freight paid to New York.

Newburgh, March 1, 1852.

[3-2]

Linnean Garden and Nurseries, Flushing, N. Y.

WM R PRINCE & CO, in addition to their immense stock of Fruit and Ornamental Trees of the usual sizes, have 10,000 Pear Trees of bearing size, 5 to 8 years grafted on both Pear and Quince; and extra sized Cherries, Plums, Apricots, Apples, &c. The collection of Evergreen Trees is unequalled, and of every size from seedlings to fifteen feet high. All will be sold low in quantities.

Priced Catalogues sent to post-paid applicants enclosing stamps. Also, a Wholesale Catalogue for Nurseries.

Cedrus Deodora and Lebanon, Yews, Junipers, Pines, Spruces, Arbor Vitæ, &c., of large sizes. [3-1*]

Fruit and Ornamental Trees.

ELLWANGER & BARRY beg to remind those who intend to plant next spring, that their stock of Standard Fruit Trees for orchards, Dwarf Fruit Trees for gardens, Ornamental Trees for streets, parks, gardens, and pleasure grounds, Shrubs, Roses, &c., is very large, and offers great inducements to those who desire first rate articles.

A complete Descriptive Catalogue is sent gratis to all who apply post-paid and send stamps for postage, which must now be pre-paid—5 cts. for 500 miles or under; 10 cts. over 500 miles and below 1000. A Wholesale Catalogue also furnished.

See advertisement of Shrubs, &c., &c.

Mount Hope Nurseries, Rochester, N. Y., March 1, 1852.

Osage Orange for Hedges.

WE can furnish any number of fine yearling plants at \$1.50 per 100, or \$10 per 1000, or at \$3 where 2000 or more are taken. Orders should be sent early. It takes about 32 plants to the rod, planted either in single rows at six inches apart, or in double rows a foot apart—either of which makes a good hedge. ELLWANGER & BARRY.

Rochester, N. Y., Jan., 1852.

GENEVA NURSERY,

CASTLE STREET, GENEVA, N. Y.

W. T. & E. SMITH, proprietors, invite the attention of Fruit Growers and Planters of Trees generally, to their large stock of well grown Trees, grafted and budded by the proprietors themselves, with great care. Greater inducements are offered here than at any other nursery. Our stock of Trees consists of 49,000 Apple Trees, well grown, with fine heads; 10,000 Pear, the best sorts; 12,000 Cherry, fine trees; 30,000 Peach, one and two years old; 1,000 Plum; 2,000 Isabella Grapes, one and two years; Apricots, Nectarines, Almonds, Dwarf Pears, Dwarf Apples, Dwarf Cherries, Raspberries, Strawberries, &c. &c. Ornamental Trees, Roses, Dahlias, Buckthorn, English Hawthorn, Scions for grafting, Seedlings, &c.—together with a general assortment usually found at other nurseries. [3-11*]

Fruit Trees.

I AGAIN offer a large stock of Trees—about 100,000—of fine thrifty growth, composed in part of Apple, Pear, Peach, Cherry, &c.; together with an assortment of Green-House Plants suitable for bedding out—all of which are offered at extremely low prices.

Wholesale prices of Apple Trees will be from \$9 to \$10 per 100.

I would recommend to buyers, after examining other nurseries, to inspect mine before purchasing.

CHARLES POWIS,

Greece, Bidge Plank Road, N. Y., March 1, 1852.—3-2t.

State Agricultural Warehouse.

THE Subscriber would respectfully invite the attention of Farmers and planters to his varied assortment of Agricultural and Horticultural Implements, among which may be found Prouty & Mears' celebrated and highly approved Center Drought Plows; Emery & Co.'s Improved Railroad Horse Power and Thresher, all of which took the first premiums at the late State Agricultural Fair, and are unequalled by any now in use; together with the latest and most improved Plows, Straw Cutters, Fanning Mills, Corn Shellers, Seed Sowers, Cultivators, Harrows, &c., &c., which I will sell at as low rates as any similar establishment in the United States.

I shall at all times have on hand a full stock of Field and Garden Seeds, Guano, and all other fertilizers in the market, which may be had on the most reasonable terms.

Persons purchasing articles from me may rely upon their giving satisfaction, as I intend keeping only such as I can fully warrant.

A. LONGFETT,

March, 1852.—3-1t. No. 25 Cliff street, New York.

Plows! Plows!!

WE are now getting in our spring supply of the celebrated Eagle Plows from Boston; also, the justly celebrated Curtis Plow, made by H. C. Curtis, Albion. These Plows stand unrivalled in this country, and are made expressly for use. They are made of superior timber, and the workmanship cannot be beat in this or any other country. All Plows sold by us are warranted to perform as recommended, or they may be returned and the money refunded.

J. RAPALJE & CO.,

Genesee Seed Store and Agricultural Warehouse, Rochester, N. Y.

March 1, 1852.

For Sale.

ONE of the best Devon Bulls in the State of New York, 4 years old this coming spring. Said Bull may be seen on my Farm, 3 miles west of Rochester, on the plank road in the town of Gates, Monroe county, N. Y. Pedigree, price, &c., may be obtained by personal application, or by letter addressed to the subscriber at the Rochester, P. O.

March 1, 1852.

WILLIAM R. BOOTH.

Peruvian Guano.

THE undersigned has received his supply of Guano, put up in bags of 100 lbs. each. The bags are branded "Genuine Peruvian Guano, No. 1, Imported by Theodore W. Hiley, New York," which is warranted pure. For sale by

A. LONGFETT,

[3-11]

25 Cliff street, New York.

50,000 Osage Orange Plants,

ONE YEAR'S GROWTH, price \$8 per 1000. No charge for packing or cartage, if \$200 or more are ordered.

OSAGE ORANGE SEED, at the lowest market price, wholesale or retail, as early in the winter as the new crop can be obtained from Texas.

M. B. BATEHAM.

Columbus, Ohio.

[1-21]

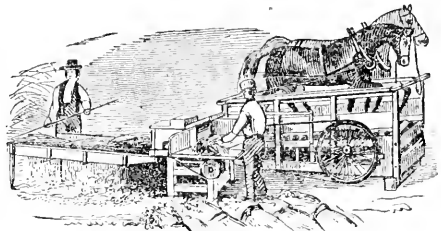

ALBANY AGRICULTURAL WORKS.
Hamilton, Liberty and Union Sts.

THE subscribers are the originators and sole proprietors of the above works, which embrace a very large collection of labor-saving Machinery, not excelled in this country for facilitating the manufacturing of Agricultural Machinery to any desired extent, and with uniform accuracy and despatch.

WAREHOUSE AND SEED STORE,

369 AND 371 BROADWAY.

Our Warerooms are among the most spacious in the city, and collection of articles on hand large and new—most of the implements being of our own manufacture, and the Seeds grown for our own trade.

EMERY'S PATENT N. Y. STATE AG. SOCIETY'S FIRST PREMIUM RAILROAD HORSE POWER, AND OVERSHOT THRESHER AND SEPARATOR.

The above Horse Powers have been awarded the highest Premiums at the Fairs of the New York State Agricultural Society in 1850, and again in 1851; also, the highest Premium at the Michigan State Fair, at Detroit, in September, 1851, where a majority of the Committee owned and were using Wheeler's Powers on their farms, having purchased them previous to selecting our own; also a Gold Medal at the American Institute in 1851. It was also exhibited at the State Fairs of Ohio, Maryland, and Pennsylvania, and received the highest awards which could be given by the rules of their Societies. In every case, it has been in competition with all endless chain Powers of any note in this country—among which were Wheeler's Rack and Pinion. All of our Powers have the name, EMERY & CO., cast upon every link of the chain and hub of band-wheel. None others are genuine.

All the above are offered on liberal terms, at Wholesale or Retail, at the Albany Agricultural Warehouse and Seed Store, 369 and 371 Broadway, Albany, N. Y.

Catalogues gratis, on application.

March, 1852.

EMERY & CO.

Cochin China and Shanghai Fowls for Sale.

THE subscriber has for sale a few pairs of his celebrated stock of *Cochin China* fowls, of his own importation, warranted true to their name and not excelled by any other stock in the country for good qualities. Also, a few pairs of the Marsh Stock of *Shanghaes* and *Samatra Game Fowls*. Reference given in regard to them, if desired.

EGGS FOR SETTING.

Eggs furnished from the above stock carefully packed for transportation, and orders for the same addressed to the subscriber will be promptly attended to. Price of Eggs \$2 per dozen.

[3-21]

CHARLES SAMSON,
West Roxbury, Mass.

Potato Onions.

FIFTY BUSHELS genuine English Potato Onions for seed, now in store and for sale, at \$2.50 per bushel, at the Genesee Seed Store, 65 Buffalo st. Rochester, N. Y.

March 1, 1852.

J. RAPALJE & CO.

Notice.

THE undersigned has disposed of his interest in the "State Agricultural Warehouse," No. 25 Cliff street, New York, to Mr. A. Longfett, who will in future conduct the business on his own account. GEO. H. BARR.

New York, Jan. 10, 1852.—3-1t.

50,000 Apple Stocks Wanted.

TEN TO FIFTY THOUSAND Seedling Apple Stocks, of thirty two years' growth, are wanted and will be paid for in Cash. Apply, or send samples, with price, immediately, to

January 1, 1852.

JAMES VICK, Jr.
Genesee Farmer Office.

Prices of Agricultural Products at the Principal Markets in the United States. — Mar. 20, 1852.

	New York.	Boston.	Rochester.	Chicago.	Cincinnati.	Pittsburgh.
Beef, per 100 lbs.	\$4.50	\$7.00	\$4.00	\$4.00		
do mess, per bbl.	6.00	8.00	4.75	4.25		
Pork, per 100 lbs.	8.50	10.00	11.00	11.50		
do mess, per bbl.	14.00	16.00	15.00	16.00	\$14.00	
Lard, per lb.	9	9 1/2	10	10	6 1/2	8
Butter, do	16	25	16	20	12	15
Cheese, do	6 1/2	7 1/2	6	8	7	7
Flour, per bbl.	4.87	6.00	4.75	6.00	4.25	4.75
Wheat, per bush.	1.17	1.22	1.22	1.22	93	93
Corn, shelled, per bu.	73	72	70	71	43	43
Rye, do	76	74	75	69	70	70
Oats, do	40	45	40	45	31	31
Barley, do	76	80	95	1.00	67	70
Clover seed, do	8a9 1/2 pr. lb.	9 a12 per lb.	4.75	5.25	12 1/2 per lb.	5.80
Timothy seed, do	14.18 per ton.		2.00	2.50	2.25	1.25
Flax seed, do	1.35	1.37 1/2	1.50	1.60	1.25	1.00
Hay, per ton	17.00	18.00	13.00	15.00	8.00	13.00
Wool, per lb.	30	44	31	46	30	40
Wood, hard, per cord		6.00	7.00	4.00	3.25	5.00

CONTENTS OF THIS NUMBER.

Agricultural Chemistry	73
Culture of Tobacco	76
Amount of Water given off by Plants during their growth	77
Flax Culture	79
Spring and Summer work	81
National Agricultural Society	83
Agricultural Implements at the World's Fair	84
LADIES DEPARTMENT—	96
EDITOR'S TABLE—Inquiries and Answers; Notices; &c.	97

HORTICULTURAL DEPARTMENT.

Strawberries	90
Culture of the Fuchsia	92
Two Fine Foreign Pears	93
Perpetual Roses	94
Severity of the Winter; Hyacinths for Forcing	95

ILLUSTRATIONS.

Figure illustrating experiments on amount of water given off by plants	77
Garrett's Patent Horse-Hoe—Side view	85
Garrett's Horse-Hoe—End view	86
Patent Drag, Harrow, and Scarifier	86
Patent Trussed Whistle-Trees	87
Grain Crusher	87
Croskill's Archimedean Root-Washer	88
Steam Engine for the Farm	89
Strawberry, Burr's New Pine	90
do. Hovey's Seedling	90
do. British Queen	91
do. Elton	91
Pear, Doyenne Boussock	93
do. Duchess of Orleans	93
Ten Weeks Stock	96

Union Agricultural Warehouse and Seed Store.

RALPH & CO., No. 23 Fulton Street, New York, near Fulton Market, Dealers in all the most approved Agricultural and Horticultural Implements; Imported and American Field and Garden Seeds; Ornamental Shade and Fruit Trees; Guano; Bone Dust; Poulrette, &c. Wrought Iron Plows, Trucks, Barrows, &c., &c., always on hand. Also, the Excelsior, or California Plow. [3-31]

Tobacco Seed.

TWENTY POUNDS first quality Connecticut River and Virginia Long Leaf Tobacco Seed now on hand and for sale at the Genesee Seed Store. The Seed can be sent in ounce packages, by mail, to any part of the United States. Packages, \$1.00 per ounce—4 oz. for \$3.00 Postage paid.

J. RAPALJE & CO.
March 1, 1852. 65 Buffalo St., Rochester, N. Y.

A Farm Wanted.

A FARM of from 40 to 50 acres, with a good house and out buildings. It must be well adapted to Fruit culture. A letter, post-paid, giving a description of the property, and mentioning terms, addressed to SMITH, to the care of EVANS & Co, Southern Hotel, Buffalo, will receive an immediate answer. [3-11]

To American Inventors and Purchasers of Patent Rights.

DEWITT C. LAWRENCE, late Chief Clerk of the U. S. Patent Office, having resigned for the purpose of resuming his profession in connection with the business of that office, tenders his services to American Inventors as Solicitor for Patent Rights. All the necessary papers and drawings prepared for obtaining Patents, and personal attendance given at the office on all business entrusted to his agency. Examinations made to determine the patentability of inventions, previous to incurring the expense of making application, upon a rough sketch and description being furnished accompanied by a remittance of \$5.00.

Investigation made, and advice given, as to the validity of Patent Rights; and searches of the records in reference to title to territory conveyed, including the fee for recording an assignment, upon a like remittance of \$5.00. Current Bank notes will be received at par, thus avoiding the risk incurred from the transmitting of specie by mail.

Refers to Hon. L. Cass, Hon. A. Felch, and the Members of the 31st Congress generally.

Washington City, D. C., March 1, 1852.

Cranberry Vines.

100,000 CRANBERRY PLANTS fine for transplanting, and can be packed and forwarded to any part of the Union. They are of the variety raised in New England, and abundant bearers. For sale by F. TROWBRIDGE, New Haven, Conn. [3-11*]

The Practical and Scientific Farmer's own Paper.

THE GENESEE FARMER,

A MONTHLY JOURNAL OF

AGRICULTURE AND HORTICULTURE,

ILLUSTRATED WITH NUMEROUS ENGRAVINGS OF Farm Buildings, Domestic Animals, Implements, &c.

VOLUME XIII, FOR 1852.

DANIEL LEE & JAMES VICK, Jr., Editors.

P. BARRY, Conductor of Horticultural Department.

Fifty Cents a Year, In Advance.

Five Copies for \$2—Eight Copies for \$3, and any larger number at the same rate.

All subscriptions to commence with the year, and the entire volume supplied to all subscribers.

Subscription money, if properly enclosed, may be sent (post-paid or free) at the risk of the Publisher. Address to

DANIEL LEE,

December, 1851. Rochester, N. Y.

POSTAGE on THE GENESEE FARMER.—50 miles or under, five cents per year; exceeding 50 miles and not over 300, ten cents; exceeding 300 and not over 1000, fifteen cents; exceeding 1000 and not over 2000, twenty cents; exceeding 2000 and not over 4000, twenty-five cents; for any distance exceeding 4000, thirty cents.

STEREOTYPED BY J. W. BROWN, ROCHESTER, N. Y.

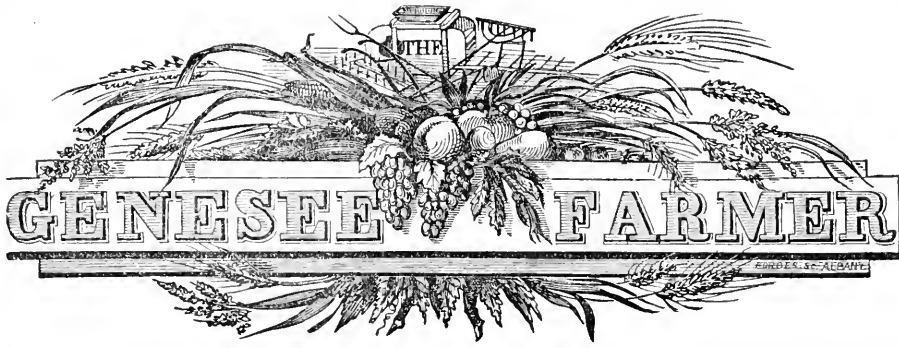

COWS AND CARROTS.

Mr. J. G. Hoyt, of Exeter, N. H., writes a letter of inquiry to the *New England Farmer*, asking information as to the value of carrots for milk cows, in which the opinions of several dairymen are cited to the effect that carrots do not sensibly increase the quantity of milk given, but they improve its quality and augment the per centage of butter. The editor of the *Farmer* quotes authorities whose statements are corroborative of the above.

It is a little remarkable that, after carrots have been extensively grown and fed to cows for thirty years, no one in New England appears to know the relation which 100 lbs. of this root and 100 lbs. of good hay, grass, or corn meal, bear to any given quantity of milk. If our friends there do understand the practical operations of milk-making, they will thank us for giving them an opportunity of informing us New Yorkers how many pounds of milk 100 of green clover, timothy, herds-grass, blue grass, orchard grass, or a mixture of any two, or of the whole of them, ought to yield in the system of "a good cow." We have visited Massachusetts twice in the last two years, and made particular inquiry on this point, as well as to the relation that 100 pounds of good hay, and a like weight of corn meal, bear to any given quantity of milk; but we failed to elicit any light beyond a luminous Yankee guess. Why New Englanders should be so opposed to experimental farming with a view to substitute facts for guesses, passes our comprehension, unless the constitutional desire to guess at everything be, in truth the strongest element in the mind of the people.

When a cow eats 60 lbs. of grass a day for a week together, and gives 30 lbs. of milk a day at the same time, how much of the grass goes to form the milk? If any New England State, or New York, had established an experimental farm twenty years ago, or even ten years ago, no one would now have to ask so simple a question; nor would there be any doubt as to how much milk 100 lbs. of carrots will yield when fed with steeped cut corn-stalks—the way in which we have given them to dairy cows. We have bought carrots, hay, corn meal, shorts, brewers' grains, and still slops, for the production of milk to sell; and while we do not claim to have made what our friends might consider "scientific experiments," yet our experience is decidedly in favor of carrots. Accurate scientific experiments in rural economy can not be made without costing considerable money; and so long as a State in which eleven or twelve hundred thousand cows are milked, and which produces fifty million pounds of cheese and eighty-five million pounds of butter a year, is too poor or too rich to pay for any experiments designed to increase the yield of milk from any given amount of food, we feel no obligation to give either our time or money for its benefit in that behalf.

As there are 86 lbs. of water, and sometimes 87, in 100 lbs. of carrots, they should be fed with more solid feed to realize their highest virtues, whether eaten by horses,

oxen, or cows. But men producing milk to sell rarely fail to feed liberally on slops of some kind, or roots that contain more water than green grass does, which is 75 per cent. We recently visited a pretty extensive dairy establishment near Washington, and found thirty thousand bushels of turneps well housed for feeding cows. In these turneps there is not less than 90 or 91 per cent. of pure water, and yet the milk from this dairy is said to be the best sold in the city. We have frequently heard it commended by intelligent gentlemen who know nothing of the way in which the milk is produced. Nearly all the hay is sold off this farm, and a large stock is kept on roots and cornstalks, shucks and blades. The farm is the property of Mr. CHARLES CALVERT, President of the Maryland State Agricultural Society, and contains about 2700 acres. It is grazed by some of the best Short Horns, Ayreshires, and Alderneys, in the country. Milk is sold at twenty-five cents a gallon by the quantity the year round.

From an extended observation and large correspondence, we have reason to believe that the culture of carrots and other roots for the feeding of cows and other stock, is on the increase; but it is an error to suppose that a pound of carrots is equal in value to a pound of oats for a horse or an ox. 100 lbs. of dry oats contain only 12 of water; whereas, 100 of carrots contain 86 pounds of water. One advantage in feeding carrots is, that the digestive organs separate all or nearly all of the elements of nutrition which they possess; while cattle and horses often void corn and oats whole, or only slightly digested, and in a way that the farmer loses much of the value of the grain consumed. This remark applies more to the Middle, Western, and Southern States, than to the farmers of New York and New England. The fault we find with the latter is, not that they decline to investigate the principles of good husbandry themselves, but for virtually instructing their representatives in State and National Legislatures to withhold all aid from such as desire to study agriculture as an honorable profession. Nobody knows anything beyond a guess about producing milk, meat, or wool, in the United States; not because there has been no young men of talent and industry to investigate these branches of husbandry in a critical and satisfactory manner, but because their desire to understand the laws of nature which establish the relations that rocks bear to soils, soils to plants, plants to animals, and animals to their fat, muscles, bones, milk, and wool, has been most cruelly crushed in the bud. A sneer at their "science" is simply adding insult to injury. There is such a thing as killing offspring when born and before; and this infanticide is inflicted upon rural science in its embryo state, or soon after.

We have just had the pleasure of an hour's conversation with Mr. ELIAS AYRES, an emigrant from Worcester county, Mass., to Loudon county, Va., where he has been engaged in the production of cheese for several years. He says that a given quantity of food fed to the native cows of the country, yields about half as much milk, cheese, or butter, as it would have done if consumed by such cows as are common in New England. Hogs require about a third more corn to make 100 pounds of pork in Virginia than in Massachusetts. We have in our possession many letters from practical farmers, which go to prove that some get three times more meat, wool, and dairy products from a given amount of grass, hay, grain, and roots, than others obtain. When we said that 100 lbs. of carrots *ought* to yield 50 lbs. of milk in good cows, we did not say that good cows as now kept *do* yield so much. The remark was made, as thousands of others have been, to provoke discussion, bring out the truth, and ultimately convince a majority of our readers that the time has come when the study of husbandry and tillage should co-act in this nation of farmers.

Before any considerable quantity of milk can be separated from the blood of a cow, the first and paramount wants of her system, for the purposes of constant respiration, and to repair the waste of elements in bones, muscles, nerves, and other tissues, must be supplied from her daily food. The primary wants of nature being satisfied in a skillful manner, we may then proceed to separate milk from the blood in its passage from the

extremities of arteries into veins in the udder, or lacteal gland, to the best possible advantage. In some glands, two pounds of milk an hour, or forty-eight in twenty-four hours, have been secreted; and even considerably more than this result has been attained. Now, if we could have our way in educating the youth who are to keep cows, every one should have a clear idea of nature's plan of separating from arterial blood a quart of rich milk an hour. There is no hocus-pocus black art in this beautiful operation, and a child with half an eye may see it, if his dad will only let him. If it were not for the vinegar of prejudice, and the aqua fortis of ignorance, the laws of Providence which really govern the results of farm labor would be studied and obeyed with great success in this republic. All that we contend for is the sober, steady, and diligent investigation of the laws of God. If we mistake not, our highest duty and our highest interest alike demand that His laws be regarded as the basis of all agricultural principles. From no other point of view is it possible to see agriculture as it is; or rather, as it ought to be. Principles, to be worth anything, must be founded in nature, and nature is everywhere under the control of laws established by the Creator. A knowledge of these laws is science, and anything short has little claim to that appellation. Hitherto science has done very little for tillage and husbandry, simply because its principles are treated with general neglect and contempt.

Why should whey, which contains very little butter and no cheese, be a valuable addition to the feed of cows for the production of cheese, in dairies for that purpose? The large per centage of sugar in whey supports respiration, and thereby permits food that abounds in the elements of cheese to be appropriated to the formation of milk, instead of being consumed to keep the animal warm. Nature's process for making milk, and the adaptation of the raw material to her purposes, are matters to be well understood before one can expect to see the relation that 100 lbs. of carrots or grass bear to 50 lbs. of milk, under the most favorable circumstances.

BEEF-ROOT SUGAR.

SUGAR is now not only a luxury, but a *necessary* of a civilized community—indispensable to the enjoyment and comfort of human life. Its sources are various and inexhaustible, being found in greater or less quantities in nearly every vegetable. It is divided by chemists into two kinds, *cane sugar* and *grape sugar*: the former being principally obtained from the cane, beet-root, maple and palm trees; and the latter existing in the grape and nearly all fruits. Cane sugar can be easily converted into grape sugar, but the inverse conversion has not yet been effected. Their composition is as follows:

	<i>Cane Sugar.</i>	<i>Grape Sugar.</i>
Carbon,	47.1	36.7
Hydrogen,	5.9	6.8
Oxygen,	47.0	56.5
	100.0	100.0

Cane sugar is readily obtained in a hard crystallized form, but grape sugar is crystallized with great difficulty, and is usually found in the form of molasses. Starch is convertible into grape sugar by the use of diluted sulphuric acid, and in the malting process the starch of the grain is converted into sugar by *diastase*. By the use of yeast, or other *nitrogenous*, *fermenting* substance, sugar, from whatever source obtained, is convertible into carbonic acid and alcohol, the intoxicating ingredient of all spirituous liquors, wine, beer, cider, &c., &c.

The cane contains about 18 per cent. of sugar, though by the present process of manufacturing it, little more than 7 per cent. is obtained. This is owing principally to the difficulty of expressing all the juice from the cane. Thus, while the cane contains 84

per cent. of juice, the average quantity secured by the manufacturer is but 50 per cent., and in some cases not more than 30 per cent. is obtained.

Beets have long been used in France for the manufacture of sugar; and though they were first grown and extensively used for this purpose during the continental system of embargo, when sugar was a dollar per pound, yet they are at the present time grown to a great extent in France with considerable profit, and sugar at eight cents per pound. They are also being grown in Ireland; but it is yet problematical as to whether they will pay there, the price of sugar being but six cents per pound and the climate being colder, not so well adapted for the formation of sugar in the beets. The composition of the beet, the mean of several analyses, is as follows:

Water,	87
Sugar,	8
Woody tissue,	5
	<hr/>
	100

By the processes of manufacturing now adopted in France and Belgium, from 4 to 6 lbs. of fine, white, crystallized sugar is obtained from 100 lbs. of beets; and it is but reasonable to suppose that by further improvements in the machinery, and possibly in the cultivation of the beets themselves, *all* the sugar they contain will be obtained, and this quantity augmented by special manures and better cultivation.

The cultivation of the sugar beet is similar to that recommended in the March number, page 82, for mangel wurzel, though more plants should be left per acre, as the beets do not grow so large as the mangels. The rows may be twenty inches to two feet apart, and the plants singled out from eight to ten inches in the rows. The seed should be sown the latter part of May and first of June. The plants will be ripe about the last of August. Sixteen tons per acre is the average in France, though thirty tons are sometimes obtained on very rich land. We think twenty tons per acre might be usually obtained in this country by careful cultivation and judicious manuring. Taking five per cent. as the average amount of white sugar obtained by the common manufacturing process, a ton would give 100 lbs.; or an acre of beets of twenty tons, *one ton* of sugar. This, at six cents per pound, would be \$120 per acre; and this besides the leaves of the plants and the residue of the bulbs, which are very valuable as food for cattle and hogs. The value of the beet-root in France is estimated at \$3 per ton. The cost of raising a crop of beets in this country can not exceed \$35 per acre, leaving, at this estimate, a profit of \$25 per acre for interest on land, &c. Of the cost of extracting the sugar from 20 tons of beet in this country, we can not speak very definitely; but where wood or coal is cheap, it appears more than probable that it could be done and leave a good round sum as profit for \$60.

We think the matter well deserves the serious attention of our farmers; and are glad to learn from the many inquiries we have lately received respecting the culture of sugar beets, that they are alive to its importance. We would advise to small beginnings at first, so that the loss from any error in the manufacture, if any, would be small.

The process of reducing the beets to pulp and pressing out the juice, is very similar to that commonly adopted in the making of cider. When the juice is obtained, it is placed in a furnace and about 300 grains of pure lime added for every gallon of the liquor. It is then heated and kept as near the boiling point as possible without ebullition for about half an hour. This is for the purpose of freeing the liquor from impurities. The clear juice is then run off, passed through filters of animal charcoal, or burnt bones, and concentrated by evaporation till the sugar crystallizes. In France, about four hours are occupied from the time the beets are ground till the liquid is in the crystallizing pans, though this time is considered much too long and efforts are making to shorten it. It is necessary that great expedition should be used to prevent loss from fermentation, which proceeds with great rapidity in warm weather, and greatly reduces

the amount of sugar. In the Patent Office Report for 1849 and '50, page 405, there is a most interesting article by Mons. MELSSENS, detailing a series of experiments on the best means of checking fermentation of the pulp and juice during manufacture, from which it appears that bi-sulphite of lime added in small quantities prevents fermentation and removes any discoloring matter, which often injures the sale of beet sugar. By the aid of this discovery the pulp and juice can be kept for any length of time without injury, and the necessity for hurry is in a great measure removed. The cost of the bi-sulphite of lime must be little, as the materials, sulphur and lime, are everywhere abundant and cheap, and the mode of manufacture easy and simple.

The cultivation of the sugar beet, if it can be rendered profitable, will greatly increase the fertility of the farm, as nothing is exported from it but sugar, and all the nitrogen, alkalies, and phosphates, retained as food and manure. Super-phosphate of lime is a very valuable manure for this crop.

UNDER-DRAINING.

THE reason for *under-draining* is found in these two facts: First, That water, however small in quantity, remaining stationary or stagnant about the roots of plants, is extremely injurious; experience demonstrating that no amount of manure will make a plant thrive while the roots are surrounded by stagnant water. Second, That water falling upon and *percolating through* the soil is not only not injurious, but greatly beneficial to vegetation, furnishing plants with elements which they need, and imparting strength and vigor of growth. On these two propositions the whole theory of draining hangs; and it is simply the most efficacious methods of removing the stagnant water, and rendering the soil as much like a *filter* as possible, that is matter of discussion. There is much diversity of opinion on this subject which we cannot discuss, but must give the methods generally adopted with the most success.

Stone drains were first used, then horse-shoe tiles, and now 1½-inch to 2-inch pipes pipes are found to be much the cheapest and best for draining purposes. In England this pipe, either round or flat-bottomed, is superceding all others. It was at first supposed that the water would not find its way into the pipes, but experience proves this to be incorrect, the joints affording sufficient avenues for this purpose.

In under-draining, the first thing is to provide an outlet for the water brought by the drains. This it will be always necessary to clean out to prevent obstruction, as a stoppage at the outlet or main drain renders the whole network of pipes useless. A fall of 1 in 700, with well laid pipe, passes off the water freely; but where there is plenty of fall, more should be given. The depth of drains and the distances apart will of course depend a great deal on the kind of soil and whether there are any springs as well as surface water to be removed; from two to five feet deep are the extremes, three feet being in general the best. The distance apart ranges from 16 to 100 feet on soils which need draining at all; and there are very few but what imperiously demand it.

The cost of draining depends a great deal on the price of pipes and on *the skill of the digger*. Drains can be cut, the pipes laid and covered up again, all complete, for twenty-five cents per rod. The price of tiles would vary according to facilities for making and obtaining them. Probably 1½-inch to 2-inch pipe would cost from six to eight dollars per thousand.

In cutting the drains, it is usual to throw out two furrows in opposite directions as deep as possible. It is then cleaned out about fourteen inches deep with a common spade; the next foot is thrown out with a narrower spade; and the remainder with a spade about six inches wide at the top, and gradually tapering so as to leave the bottom

of the drain just wide enough for a man's foot. The loose soil at the bottom is cleaned out with a narrow scoop, the handle being sufficiently long and so shaped that a man can clean the drains from the top.

In laying the pipes, all that is necessary is to place them end to end as closely as possible. If convenient, it is best to put a piece of turf with the grass downwards over the pipes; though this may be dispensed with if the soil is moist and care is taken not to disturb the pipes in covering them with it. After the drains have been laid and covered a few days, the water comes through *as clear as crystal*, and there is little danger of stoppage from any deposit of sediment, and few if any of the fertilizing elements of the soil are washed out.

There has been much discussion between theoretical and practical men, as to whether the drains should be laid across the natural slope of the land or lengthwise of it, practical farmers for a long time adopting the former and the scientific farmers advocating the latter. There are few at the present time but what think the scientific men are right, and the drains are laid the same way as the land slopes and empty into a main drain, laid with larger tiles, *running across the fall*. This main drain discharges the water into an open ditch, which should always be kept clean, so that the water can run off freely.

The economy of under-draining at a cost of from \$20 to \$30 per acre, has been much questioned in this country where lands are so abundant and cheap; but all those who have given it a fair trial, have no doubt of its great benefit and of its paying great interest on the capital invested. They say the soil works much easier, is ready to plow much earlier in the spring, and *yields greatly increased crops* with less manure and less labor. We have no hesitation in asserting that there is but little land on which all agricultural crops would not be increased half as much again by thorough under-draining. It is a fact which, though it appears paradoxical, is nevertheless clearly established by experience, that land well under-drained is much dryer in wet weather, and much more moist in dry hot weather, than that undrained. We believe that the general adoption of thorough draining will do much to remove the innumerable insects, blights, and rusts, which now make such fearful devastation on our crops. An old English farmer informs us that he can remember when under-draining was scarcely known in England the crops were more liable to be injured by insects, &c., than they are here at present; but now they are unknown there, and the crops have doubled, which he thinks is owing more to under-draining than any other cause.

MILCH COWS, AND CALVES.

It is impossible to choose a subject of more general interest to the agricultural community, than Milch Cows; for though there is only a portion of American farmers that devote their farms principally to the dairy business, yet every homestead has its cows, and every farmer is interested in their management.

The best time for cows to "come in" is generally considered, to be about the middle of April; though where calves are raised for the butcher, it will be profitable to have them earlier; as, being scarce, they sell much better. The period of calving is one of considerable danger, and much care is necessary to keep the cow in a healthy state, and in that condition which will make her most profitable the coming season. Cows of course should never be starved during the winter, but kept in a nice warm yard, having plenty of straw, cornstalks, or hay, regularly given them. If they are not milked, they may be kept in good condition on straw and cornstalks till within six weeks of calving, when they should have a little hay; and as the spring draws near, if not in good condition, a little corn meal, or what is much better, three or four pounds of crushed oil-cake a day, may be given for a week or so previous to calving. It is not, however,

desirable to have the cow at all fat; but as it is often the case that owing to eating a large bulk of comparatively non-nutritious food the cow becomes costive, and inflammation to a greater or less extent ensues, it is advisable to give more *concentrated nutriment*; and oil-cake, besides being more nutritious than any other food given to cattle, is a slight aperient, and keeps the cow in a fine healthy state. It may be continued as long after calving as the farmer pleases—it will do no harm—nothing, in fact, producing more or richer milk. Whether it will *pay* to feed it, we are unable to say. Mangel wurzel being also laxative and very nutritious, are valuable food for cows at this period; and nothing will *pay* a farmer better than to grow a few acres every year for this especial purpose. Ruta бага are good, but are apt to give an unpleasant flavor to the butter. They are not so aperient as mangel wurzel. After the cow has calved, she should have some warm slops and be carefully attended. The first milk should be drawn out of the bag before the calf sucks; and afterwards, if the bag is hard, it is sometimes advisable to get as much of the milk as possible previous to letting the calf suck, so that he may knock on the udder, and well clean out all the milk.

When fattening for the butcher, the calves should always be placed in a dark place and be tied up, so that they can not run about. It is very necessary that they be often well cleaned out and littered with plenty of clean straw. This will keep the calves healthy, clean, and free from lice. In the celebrated cheese county of Cheshire, England, the calves are never suffered to suck the cows at all, but are fed with skim milk and boiled linseed or oil-cake meal, which they are taught to drink out of a pan or pail. We think this is an *unnatural* plan, and the benefits derived by it do not, or at least would not in this country, counter-balance the extra trouble. When designed for rearing, this plan may have its advantages; but the calf at first should undoubtedly be fed with the biestings or first milk, as, being the natural food, it is best adapted for the functions of the stomach and bowels. It is slightly purgative, and cleans out the black feces which are in the calf when born. After the first week or two the fresh milk may be substituted by skim milk and boiled linseed or oil-cake, which should be given two or three months before the calf is weaned. Nothing pays better than to keep rearing calves *well* the first four months, giving them a good start in life. We would not advise the confinement of rearing calves; for, though it may conduce to laying on fat, the formation of muscles and bones and the general health of the animal is lessened.

Every one knows the great necessity there is of being gentle and kind to cows, so that they may be quiet and peaceful, and not stand trembling in durance vile while being milked. It is this that accounts for the opinion that a cow will give a dairy-*maid* more milk than she will to a man. We think a man, during the milking season, has seldom any business near a cow, his great, rough, hard hands, and still harder heart, rendering him unfit for a good milker; while a gentle, rosy dairymaid, with her kind words, soft hands, and "So, so, my good bossy," seated on a three legged stool, will fetch out the milk till the froth runs over the pail. Cows should be milked regularly the same hours every day, and should have access to water and shelter at all times.

WILLOWS.—There are \$5,000,000 worth of willows imported into this country every year from Belgium and France, for making baskets, and for other purposes. They sell for \$125 per ton, and the demand is greatly increasing, and is now much greater than the supply. They grow equally well in America as in Belgium, but need low, swampy land, that is fit for nothing else. They need no cultivation at all. In planting the first time, all that is necessary is to stick the cuttings into the soil in the spring. The next fall the first years' shoots should be cut down; and the next year they will come out thick and strong, and yield an abundant and most profitable crop. The common English willow, or osier, is the best variety for baskets.

LARGE CROP OF RUTA BAGA.

WE have received a communication on the culture of ruta бага, from JOHN T. ANDREWS, Esq., of West Cornwall, Conn., which we are sorry the limits of the *Farmer* will not allow us to publish. It is full of valuable information, and affords encouraging evidence of the successful application of skill and science to farm husbandry. Mr. ANDREWS says: "I devoted my head and hands to the work of agriculture with the full intention of convincing my neighbors that the idea that a collegiate education spoils a man for a farmer, is a popular error. I have succeeded so well that, though this is my second year at farming, I have taken first premiums this fall, at our County Fair and American Institute, on my cattle, sheep, poultry, turneps, potatoes, and ruta бага. I must add, further, lest you should mistake me for a gentleman farmer, that the labor on my little farm is performed almost exclusively by my own hands. For much of the little I have learned of the art of farming, I am indebted to the *Genesee Farmer*, *Working Farmer*, and *Albany Cultivator*, of which I am a constant reader. *To these I owe my success.*"

The quantity of land cultivated with ruta бага was one-fourth of an acre. The soil was heavy and retentive of moisture, but safe from standing water by a gentle descent. It had been for many years a meadow, and yielded but half a ton of hay per acre. It was plowed, manured with twenty loads of manure per acre, and planted with potatoes, *which were a complete failure.* The next year it was plowed again twelve inches deep, and twenty more loads of manure applied per acre. After lying a few weeks, forty loads of manure per acre were spread over the surface and plowed in seven inches deep. It was afterwards plowed and dragged till the manure was thoroughly incorporated with the soil. Furrows were then drawn with the plow, twenty-seven inches apart, in which was spread a mixture of guano from the poultry yard, nightsoil, ashes, and gypsum. The furrows were then turned back over the manure, leaving the ridges twenty-seven inches between. Four or five seeds were then dropped on the ridges in holes about ten inches apart, and slightly covered with the garden rake. When the plants were sufficiently large to be clearly distinguished from the weeds, which were very numerous, the hoe was vigorously applied, destroying all the weeds and leaving one plant in a place. They were sown on the 20th of June and gathered on the 6th of November. The leaves were very large, of a dark green color, reaching from one ridge to the other, completely covering the ground. When gathered they were thrown into heaps of about 100 bushels each, and covered with straw and earth, to remain in the field until needed for use. The crop yielded, by actual admeasurement in a sealed bushel, 416½ bushels, or *one thousand six hundred and sixty-six bushels per acre.* This, at 50 lbs. per bushel, would be 41½ tons of bulbs per acre, besides a large quantity of leaves, themselves valuable food for milch cows, &c. We speak advisedly when we pronounce 41½ tons of bulbs per acre a larger crop than has ever been raised in Great Britain. 25 tons is there considered a first rate crop, and is seldom exceeded.

The quantity of manure which our friend applied appears excessive, and we hope, for the sake of agriculture, quite unnecessary. Twenty loads of good manure to the acre is a heavy manuring for ruta бага, and if to this is added 300 lbs. of super-phosphate of lime, sown with the seed, a good and profitable crop will be obtained. Ruta бага possess great power of drawing their nitrogen from the atmosphere, if supplied with available phosphates and carbon; but if large quantities of nitrogen are supplied in the manure, which was the case in the above experiment, this is employed in the organism of the plant, and its nitrogen-collecting powers are useless.

We hope to hear again from our friend, and trust he will continue to unite science with practice, be as successful in his experiments as in the one just detailed, and, successful or unsuccessful, give his results to the readers of the *Genesee Farmer*.

Condensed Correspondence.

DURING the last few months we have received a vast amount of useful information from many valued correspondents, which has necessarily been crowded out of our columns. We hope our friends will still continue to write and give us information, which in one form or another will find its way to the readers of the *Farmer*. Especially do we like to hear from practical, keen, observing, thinking farmers. It is by uniting facts furnished by such men and the indications of science, that a true system of agriculture will be formed. We give extracts from the communications that have accumulated on our hands, and shall try to give the greatest amount of information in the fewest possible words.

BUTTER-MAKING EXPERIMENTS.—The experiments on butter-making, detailed in your February number, were made in *cool November*. Mrs. B. is quite certain the result would be different and in favor of the small pans of milk, if the same experiments were to be made in *hot weather*. I hope L. N. will make further trials next summer. R. B.—*Fort Covington, N. Y.*

THICK AND THIN SOWING.—Some of my neighbors think that wheat, whether sown thick or thin, will grow about so thick. So last fall I selected three lands as near equal as I could find in the field: the first I sowed at the rate of one and a half bushels to the acre, (my common gauge); the second, three bushels; and the third, three pecks. At harvest, that sown with one and a half bushels was the best; the three bushels was too thick and the heads small; and the three pecks to the acre was too thin, *rusted and shrunk*. ALPHEUS CALVERT.—*Reading Center, N. Y.*

TO CLEAN SPRING WHEAT FROM CHESS, OATS, &c.—I observed an article in the December number of the *Farmer* about washing spring wheat, to free it from oats and fowl seeds. I send you another method, which I think is much better, as I have tried both. Take the fanning-mill with the chess-board placed so far up in the shoe that by turning fast the good wheat will drop in the mill, and the oats, poor wheat, and other light materials, will blow away, leaving the wheat cleaner than if it had been in water. This method is one of the best for cleaning chess, &c., from winter wheat for sowing. SENECA LAKE.—*Romulus, N. Y.*

PLANTING SMALL POTATOES.—I have noticed of late, that the more manure you put on the ground for potatoes, the smaller is your crop; and it is a well known fact, that the largest and best potatoes in the hill are the first to decay. In 1850 I planted half an acre of green sward, plowed in the spring, without any manure, and from necessity used the smallest potatoes I had for seed. I hoed them but once, and gave them a sprinkling of plaster after hoeing. The result was, I obtained from the half acre sixty-five bushels; and at the time of digging (the middle of October) there was not one peck of decayed potatoes among them. Last year I adopted the same course with similar results.

This year I propose to plant, for experiment, in an open woodland and cover with forest leaves, and will apprise you of the result, feeling that whatever interests the mass of farmers as much as this subject, should be looked to and as much light thrown on the subject as possible. A SUBSCRIBER.—*De Lancey, N. Y.*

HOME-MADE GUANO.—I see by different agricultural publications the anxiety many farmers have of enriching their soil by lime, gypsum, guano, &c., at considerable expense, and at the same time suffering a large amount of the best fertilizing ingredients to be thrown to waste, which would cost them nothing to preserve. In the fall and spring I cart many loads of any kind of soil I can procure free from stone to a heap near my kitchen and wash-house door. I put it up like a coal pit—large at the base and small at the top. The top I make concave, so as to contain half a barrel of water. To this top I place a plank to which slats are nailed to walk up on, and I have all the dish water, soap suds, chamber-lice, meat and fish pickle, and every kind of refuse from in and about the house, carried to this heap. I frequently add a little plaster. After it has been there six months, mix it well, haul it out, and supply its place with another heap. It is a cheap manure, and far exceeds lime, gypsum, or guano; all of which I have used to a large extent. S. JOHN.—*Mount Comfort, Pa.*

MERINO, SOUTH-DOWN, AND LEICESTER SHEEP.—I keep three kinds of sheep, Merino, South-Down, and Leicester. Some time ago I sold part of the flock for mutton. The Merinos brought me \$1.50; the South-Downs, \$2; and the Leicesters, from \$2.50 to \$3. The butcher would always pick out the Leicesters, and I found it impossible to sell the others while they remained in the flock. I drew them out and disowned them, and thus was enabled to dispose of the others. The South-Downs were fair, profitable sheep—about the medium in Western New York. I can recommend the Leicesters; not because I have them to sell, but for the reason that they are more healthy, look better, shear more wool, grow faster, and pay better. The lambs sell for a higher price and much earlier than the other breeds, in Western New York. A YOUNG DUTCH SUBSCRIBER.—*Royalton, N. Y.*

SOAKING CORN IN A SOLUTION OF HARTSHORN.—A few years since, hearing a neighbor speak of the great value of soaking seed corn in a solution of hartshorn previous to planting, I was induced to try it, and have met with perfect success. I put two ounces of the hartshorn, costing twenty-five cents, to a peck of corn, cover the corn with water and let it stand six hours, planting as soon as possible, rolling it in plaster as I plant.

Two years ago we had a dry time just as our corn was nicely up, and all corn fields in this region looked yellow and sickly, while my corn planted as above kept of a dark green color and grew well till harvest, when I had 100 bushels of corn per acre, which we consider a good crop here. My neighbor who planted in an adjoining field, on much better land and well manured, but who did not use the hartshorn, had a very poor crop. I induced a neighbor to use it last year, and he obtained equally beneficial results. WARREN EKA.

EXPERIMENT WITH POULTRY.—I have been keeping an account with my poultry the past year, to ascertain whether any profit could be derived from them. I commenced on the 1st of January, 1851, with twenty-three hens and two ducks. The hens were of the *Poland* variety, but not full blooded, and were mostly two years old. They were not confined, except a few weeks in spring and summer. I allow them two quarts of corn per day, except through the last of summer and first fall months, when they require less. The hens commenced laying about the middle of January and laid till November. The account from January 1, 1851, to January 1, 1852, is as follows:

<i>Dr.</i>		<i>Cr.</i>	
To 19 bushels 3 pecks corn,.....	\$15 59	By 2685 eggs, worth, at market prices,.....	\$32 02
" 111 eggs used for sitting,.....	1 36	" 25 chickens raised,.....	5 31
" Indian meal for chickens,.....	1 64		
	\$18 59		\$37 33
		Balance in favor of poultry,.....	\$18 74

I commenced killing off my hens in July, and when they ceased laying in November I had but eleven. It would be fair to set down the average number for the year at eighteen. The two ducks layed 142 eggs, which leaves for the eighteen hens 2543 eggs, or an average of 141 eggs each, besides raising chickens. S. B. SMITH.—*Saugerties, N. Y.*

GUANO ON CORN.—Reading in the *Farmer* of the value of guano as a fertilizer, I ordered half a ton from Philadelphia. When it arrived, I turned to the *Farmer* for information how to prepare and apply it, but could find no directions there. I then applied to the merchants who sold it; but they were ignorant on the subject. Here, then, was a dilemma: the time for planting had arrived, the guano was on hand; but how to apply it, was the perplexing query. I had learned it was necessary to pass it through a sieve. I got a No. 6 and went to work, but soon gave it up, the odor and dust being exceedingly disagreeable. I had prepared my seed for planting, all of which was of a kind known here as the *Red Cob*, except a single ear of *Oregon*, which I had procured from Philadelphia, and for which the farmers in that vicinity paid \$1.50 per bushel. This seed I planted first, and being desirous of making the best of it, gave it about half an ounce to the hill of the sifted guano previous to covering. The rest of the field of twelve acres was planted without the application of any manure at all. This came up in about six days; but my *Oregon*, which I expected to appear first, showed no symptoms of breaking ground. I waited ten days, and then commenced making search for the hidden treasure, which on finding appeared to be in a state which I can only describe as between a fry and a stew. Some of it eventually came up, made large stalks, and ears not one of which matured. Thus I lost my seed, labor, and guano. When the corn on the remainder of the field was up about six inches, I applied a mixture of equal parts of guano and coal ashes, about one-third of a gill to a hill. The soil was poor and had never yielded fair corn crops before; yet I obtained 800 bushels of

very superior corn, with scarcely a soft ear to a wagon load. Last year (1851) I dressed twenty acres in the same way, at the same rate, and had as the result 1300 bushels of ears—a larger quantity than has been raised on the farm for the last twenty years in all.

I am not sure that the manner I adopted of applying the guano is the best. It is evident from the experiment made with the *Oregon*, that its immediate application to the seed is injurious, though applied in smaller quantities it might not prove so. On vines, (cucumbers, squashes, melons, &c.,) applied near the stem in the hill, the effect was astonishing. A SUBSCRIBER.—*Bear's Gap, Pa.*

BEES.—The greatest difficulty I have with bees, is their robbing each other. To prevent it I have tried several experiments, but have failed in all except this: If hive A attacks hive B, change them—put A in the place of B, and B in the place of A; and if three or four should be in the fuss, change them all in the same way. By this means I have never failed to stop them in less than half an hour.

In regard to the moth I have but little trouble. I take corn meal and make a paste with strong salt water, spread it just the bigness of the hive half an inch thick, and place the hive square on the dough, making it all tight except the entrance, and this the bees will guard against the miller, which lays her eggs under the edge of the hive; and with this preventive I have no trouble with the moth. The hive should not remain in this condition after it is filled by the bees, but should be raised on blocks one inch thick. This gives the bees fresh air, and prevents the comb from melting down, which frequently happens in extreme hot weather. In this way they will also stand the winter better than if set close down, when their breath forms a frost which melts and runs down the hive, freezing when it strikes the board at the bottom. In this way I have lost several good swarms, with thirty to forty pounds of honey in the hive. IRA YOUNG.—*Conquest, N. Y.*

CULTURE OF TOBACCO.—We have received an excellent article on this subject, from Mr. H. N. HOWE, Marcellus, N. Y., from which we give such facts as throw additional light on the subject:

Having prepared the beds, sow the seed (a table-spoonful to thirty square yards) if possible just before rain on a *still day*, or you may find the plants in some other place. Keep the beds free from weeds. It will answer to sow the seed from March till the first week in May. Any land that is natural for corn is good for tobacco. To ensure a large crop of either, any man knows that the ground must be well prepared and manured before planting. Mark the ground from three to three and a half feet one way and two and a half to three feet the other: this is for Connecticut Seed Leaf; the small kinds will bear to be thicker. Some think the plants should be three to four inches high before setting; but this I think a mistake. I commence setting when the plants are no larger than a fifty cent piece, and I invariably have good luck with my early set plants. A plant five inches high before setting will generally die to the ground; whereas a small one, if well set, will scarcely mind the removal. It will do to set in missing plants till the first week in July. The cultivator may be used as long as it will pass without breaking the leaves. The plants require no hill: they should be hoed two or three times; the first as early as practicable. When the plants show the buds fairly, they can be pinched off, leaving from sixteen to twenty leaves on a stalk; late plants must be topped lower. After topping, the suckers must be kept off; the cleaner the better for the growth of the plant, and the convenience of handling when stripping. When the leaves become spotted with yellow, the plant is fit to cut. It is best to have the dew off before cutting; and after rain the plants should not be cut for a few days, as the rain washes the gum from the leaves. When cut, the plants must be laid carefully on the ground to wilt. If the sun is hot, care must be taken or the plants will burn, and the places burnt are spoiled. In hanging, fasten the twine around the butt end of the first plant, fetch it across the pole, give it a turn round the next plant, and so on to the other end of the pole. The poles, or whatever is used to hang them on, ought to be sufficiently large to prevent the plants from pressing each other too much, as in such a case they are apt to spoil before they get sufficiently wilted to hang independently of each other. When the leaves are all cured and the middle stem of the leaf has become dry, and there come a few damp days, the plants will be moist and can be taken down without breaking the leaves. They should be laid in piles of two tiers, the tops together. After lying a few days it can (if the weather is not too dry) be stripped and done up in hands and packed away till ready to be boxed. Sweating can be done before or after stripping. If done before, it must be closely watched or it will become too hot and damage. Care should be taken in every operation to not break the leaves. The crop ranges from ten to twenty hundreds per acre.

AGRICULTURAL PRODUCTIONS, AS SHOWN BY THE CENSUS OF 1850.

State.	Acres of land improved.	Value of farming implements and machinery.	Value of live stock.	Wheat, bushels of.	Indian Corn, bushels of.	Tobacco, pounds of.	Ginned Cotton, bales of 400.	Wool, pounds of.	Wine, gallons of.	Butter, pounds of.	Cheese, pounds of.	Hay, tons of.	Hemp, dew-rotted, tons of.	Hemp, water-rotted, tons of.	Flaxseed, bushels of.	Maple sugar, pounds of.	Cane sugar, lbs. of 1,000.	Value of homemade manures.
Maine.....	2,019,698	\$2,368,517	\$9,838,185	367,950	1,741,715	1,366,666	396	88,885	2,201,105	794,780	92	87,541	..	\$310,995
N. Hampshire.....	2,251,426	3,214,425	8,871,901	185,658	1,573,670	9	9	1,108,476	305	6,977,656	3,196,563	598,554	304	1,292,429	..	893,455
Vermont.....	2,322,925	3,773,569	11,299,745	268,658	1,625,776	3,492,087	140	12,428,965	6,755,006	763,670	607	5,159,641	..	291,550
Massachusetts.....	2,127,924	3,473,939	9,619,904	290,656	1,119,306	4,922,537	4,322	7,124,461	7,124,461	647,749	5	..	72	768,596	..	210,076
R. Island.....	397,672	473,385	1,466,636	..	516,133	111,937	842	1,066,237	296,748	73,637	24,093
Connecticut.....	1,754,277	2,438,256	7,353,996	401,167	1,996,462	1,383,932	..	512,529	3,346	6,049,279	4,512,019	499,706	9,775	37,781	..	158,995
New York.....	12,856,077	22,217,563	74,672,356	19,073,357	17,844,808	10,222	..	10,921,507	6,439	82,648,253	49,755,905	3,714,734	51	20	53,824	10,310,764	..	1,277,170
New Jersey.....	1,770,337	4,207,124	10,678,294	1,508,216	8,665,396	375,632	517	9,070,710	500,819	429,174	23,359	12,353	..	110,350
Pennsylvania.....	8,619,631	14,991,933	42,146,711	15,482,191	19,707,792	837,619	..	4,784,367	29,839	40,554,741	2,395,279	1,826,265	173	686	49,627	2,278,644	..	755,104
Delaware.....	524,364	471,835	1,718,336	466,784	2,838,896	92,887	58	1,681,367	3,187	30,189	16	888	..	32,509
Maryland.....	2,767,905	2,463,443	7,997,634	4,394,680	11,104,631	21,139,251	..	477,438	2,099	4,296,160	3,925	145,070	63	..	2,816	47,740	..	111,823
Dist. Columbia.....	40,229	17,370	65,230	15,000	1,974
Virginia.....	7,021,658	35,697,962	14,516,950	33,598,552	58,516,492	2,767	..	2,800,909	4,280	11,126,795	491,850	370,177	1,419	33,333	1,223,905	2,156,073
N. Carolina.....	5,449,137	4,056,006	17,337,108	21,347,899	28,256,999	12,065,137	..	95,028	915,259	10,801	4,744,295	146,180	13	478	381,853	27,448	..	2,008,584
S. Carolina.....	4,074,855	4,143,709	13,000,015	1,066,278	16,272,530	73,235	300,901	487,235	3,650	2,979,375	4,810	23,321	11	200	150	969,546
Georgia.....	6,323,426	5,901,050	23,627,408	1,683,781	30,428,530	429,123	491,025	4,640,074	664	4,640,074	46,391	23,321	1,888,003
Florida.....	439,423	675,885	2,946,608	..	1,963,162	165,064	..	23,235	10	376,553	38,354	31,591
Alabama.....	5,066,514	3,158,738	11,639,366	292,423	28,439,606	1,535,064	..	631,249	14	829,112	20,311	13,331
Mississippi.....	1,574,630	1,167,619	3,256,252	48,349	49,743	192,637	391	48,781	20,311	13,331
Louisiana.....	3,657,918	2,905,398	10,263,966	215,181	2,539,236	25,222	..	152,664
Texas.....	635,913	1,095,398	10,263,966	48,349	49,743	192,637
Arkansas.....	790,333	1,594,941	6,738,254	193,992	2,347,206	8,374	94	2,310,724	92,405	3,924
Tennessee.....	5,687,057	5,331,173	29,134,193	1,688,177	22,137,880	192,637	..	12,106,233	210	18,134,193	179,574	72,942
Kentucky.....	6,008,628	5,383,962	29,898,786	2,184,762	28,922,788	58,765,250	1,688	10,089,697	4,831	34,180,485	21,350,378	115,296	37,168	2,85	80,458	888,925	..	3,163,116
Ohio.....	9,739,650	12,716,153	49,276,187	14,967,656	59,788,750	10,489,967	..	10,089,697	4,831	34,180,485	21,350,378	115,296	37,168	2,85	80,458	888,925	..	2,587,493
Michigan.....	1,923,582	2,764,171	9,006,429	4,918,706	6,620,215	1,235,146	..	5,502,763	1,463	10,489,967	6,620,215	394,171	704	34	1,186	2,423,897	..	1,696,601
Indiana.....	5,019,322	6,319,526	29,398,965	6,625,474	29,827,564	1,025,146	..	2,150,139	2,343	12,478,186	669,986	402,731	734	775	35,903	2,921,688	..	354,936
Illinois.....	5,114,041	6,319,526	29,398,965	6,625,474	29,827,564	1,025,146	..	2,150,139	2,343	12,478,186	669,986	402,731	734	775	35,903	2,921,688	..	1,647,201
Missouri.....	2,911,422	3,977,449	19,764,672	2,933,814	35,709,042	17,468,394	..	1,685,182	10,163	7,760,124	201,597	116,254	17,061	4,014	13,439	171,943	..	1,238,211
Iowa.....	844,173	1,292,947	4,692,719	1,442,074	8,475,927	2,012	..	383,395	420	1,683,128	198,444	84,598	1,200	1,662,749
Wisconsin.....	1,011,396	1,701,047	4,594,717	4,292,226	1,989,378	768	..	243,065	68	888,816	440,961	293,927	100	292,553
California.....	34,312	88,596	3,456,725	98,82	90,662	1,000	..	4,890	150	2,088	57,506
Minnesota.....	5,695	103,879	163,899	3,422	16,665
Oregon.....	135,357	183,463	1,873,989	22,888	2,928	29,596	..	211,734	36,030	373	1,304
Idah.....	15,219	78,495	533,561	103,441	9,144	8,897	..	74,664	32,646
New Mexico.....	161,296	78,217	1,504,497	196,575	356,745	1,115	..	32,641	2,638	101	5,887	6,081
Total.....	112,042,090	151,820,271	552,705,238	104,739,239	591,585,623	190,322,494	2,471,214	122,427,737	141,295	312,225,891	108,134,658	13,606,384	62,182	13,039	567,749	32,750,268	318,644,273	2,225,546

CULTURE OF THE GRAPE, AND WINE-MAKING.

BY L., OF IRONDEQUOIT, N. Y.

You gave in the January number of the *Farmer* much information on the science of grape cultivation and the making of wine. For the purpose of making good wine, and that which will mature itself in due time, it is of much importance to procure the right kind of grape, well adapted to the climate. Without detail on the selection and cultivation of a suitable wine-grape, suffice it to say that your correspondent, Mr. BLAKELY, of Roxbury, Conn., in his excellent article on "Wine-Making," has set forth very fully, and with much practical knowledge, the selection and propagation of the grape for wine-making. I would by no means depreciate the utility of the different modes of propagation proposed by Mr. BLAKELY, for they are among the best means of obtaining vines on a limited scale; but as no allusion was made to any other practice, in his communication, I beg leave to state that by far the most rapid and cheap way to multiply grape vines is by cuttings of the last year's growth; and it is the principal mode practiced by nurserymen in obtaining vines for their extended sales. Indeed, I suppose there may be 3000 cuttings, with three joints each, placed on a quarter of an acre; and if the soil be deeply worked, with good after culture, they will give more than half their number of well rooted vines, suitable for resetting after two years' growth.

Your paper is too valuable for me to occupy its pages with a long article, but I will venture to give a short statement of what we make wine of in Irondequoit, and how it is made.

The *Clinton* grape, as known in these parts, I consider the best adapted to making a high colored wine. This grape has rather a small berry, but is very hardy, and always matures itself in good season. I have a few barrels of wine made from vintage 1847 and '49, which prove to be of the very best quality with which I am acquainted. The greater proportion of this wine was made from the *Isabella* grape, combined with the *Clinton*. I may also state that it is selling as a choice article for sacramental purposes at two dollars per gallon.

When the grapes are fully ripe, and have been removed from the vineyard to the place assigned for making the wine, they should be assorted and all the decayed and green ones removed; then put them into a barrel, about a bushel at a time, stems and grapes, and pound them thoroughly till all the grapes are mashed. Continue the process till all is finished that you wish to make up at that time. The next process is to press out the juice or must, and to every gallon add two pounds of sugar, and stir it thoroughly till the sugar is all dissolved. After treatment is, to put it into barrels for the purpose of fermentation, there to remain, with frequent filling up to supply the waste, till the pomace is all fermented off. A supply of the must should be on hand for that purpose. The barrels should not be bunged up until the fermenting process is about complete, and by placing your ear to the bung it may be easily decided. If in April or May the wine should be found clear, it may be racked off; but if unsettled, it should remain till fall. If the wine is found to be just what you want it at the time of racking, bottle as much as you choose; but if not, let it remain on the lees, and the article will increase in character and strength.

The above mode of making wine I have practiced many years on a small scale; but for a more extended business in wine-making, the Ohio practice would be more complete.

I would remark that no grapes raised in this part of the State contain sufficient sugar or saccharine matter to make good wine without the addition of sugar.

EXPERIMENT WITH POTATOES.

BY E. HAMMOND, OF MANORKILL, SCHOHARIE CO., N. Y.

I AM trying to pursue the "most healthy and honorable—the most natural pursuit of man." I reside on that high and elevated tract of mountain land on the western slope of the Catskill range, on the eastern sources of the Schohariekill, one of which passes through my farm. The soil is a dark clay loam. The stones are red, dark grey, and light grey—flat and broken. I have been a constant subscriber to some agricultural journal for the last seven years. I desire to know why a crop is sometimes first rate and sometimes almost a failure. I desire to move with some certainty in my pursuit.

In the April number of the *Genesee Farmer* for 1851 I read an excellent article on that almost worn out topic, the "Potato Malady." It was very interesting to me. I have been experimenting on that crop for some years. I broke up a good sod for potatoes as soon as the frost was out and the ground settled. I did not plant till June 5th. The soil was in fine condition. I measured off a piece eight rods long and four rods wide to experiment upon. I planted 1st, Two rows of Carters, thirty-six hills in a row, and applied four quarts composition (three quarts leached ashes and one quart plaster) to each row. 2d, Two rows Carters; applied two quarts plaster to each row. 3d, Two rows Carters; three quarts unleached ashes and one quart plaster to each row. 4th, Two rows Mercers; nothing applied. 5th, Two rows Mercers; eight quarts of leached ashes to a row. 6th, Two rows Mercers; half a bushel of charcoal (coarse) to each row. The application was made on the potatoes in the hill before covering; nothing more applied. They were dug the last week in August.

Result.—No 1, Yield—66 quarts good; 4 quarts unsound, but not rotten. No. 2, 50 quarts perfectly sound; none unsound. No. 3, 54 quarts sound; 2 quarts unsound. No. 4, 44 quarts sound; none unsound. No. 5, 68 quarts sound, but a number of them somewhat discolored—saved for seed; 18 quarts rotten and unsound—many so rotten as hardly to hold together till measured. No. 6, 61 quarts good; 12 quarts rotten and unsound.

Now for a few facts of personal observation on the above, then a few queries, and I have done:

I observed that wherever the ashes and tuber came in contact, there was rotteness on that side of the tuber in every instance. I dug them myself with care, and my observations were as close as I was capable of making—perfectly satisfactory to myself at least. Where I applied gypsum alone, I noticed that where the gypsum and tubers came in direct contact, there was no rot or decay in any instance. I applied a gill of plaster to a hill for a few hills adjoining the above experiments. There was no increased vigor to the vine, nor apparently any increased product of potatoes, but the potatoes were perfectly sound. The vines of the 5th experiment looked beautiful and vigorous, and could be distinguished for twenty or thirty rods, and I expected great results. I expected that the charcoal in the 6th experiment would result in a rather good yield from its quantity, but I was somewhat disappointed.

Has the result of unusual rotteness following the application of ashes *directly on the seed* been observed by others? and would the result have been different had the application been made *on the hill*, so as not to come in direct contact with the tubers? Would gypsum *in the hill* and ashes and gypsum *on the hill* change the result? It appears to me that it would.

I am now done for the present on the potato experiments. I shall make further experiments the present year.

HORSES FOR THE FARM.

Notwithstanding the inroads made upon horse-labor by our great railroad system, the horse continues to be, and will continue to be, one of the most important of domestic animals. For the past year or two the price of horses, and especially *good* horses, has been advancing. Indeed it is no easy task now to get a pair of working horses combining strength, speed, hardiness, and other important qualities. Horse-breeding we believe has been, and is now, conducted in a most unskillful and deplorably careless manner. We may station ourselves on a road leading to one of our large cities, where two or three hundred teams pass and re-pass in a day, and out of the whole number we venture to say that one span of good farm horses—say sixteen hands high and weighing about 1400 lbs., well proportioned, sound, strong, and hardy,—can not be selected. We have spent some time in looking up good horses, and therefore speak from experience. The majority we find to be long-legged, long-backed, narrow-chested animals, fit only for the road before a light carriage. A man having half a dozen of them at hard work, would require a veterinary surgeon on his own establishment. Where we do find any considerable degree of strength and robustness, we find also excessive coarseness and clumsiness. We admit some exceptions, but they are few and far between. Light, active, sprightly carriage horses, and fast goers, are not scarce. The fact is, our breeders of horses have been aiming at speed too much. The immoral race-course is ruining our horses, filling the country with a mongrel race absolutely worthless.

It is time that this matter should be urged upon the consideration of our farmers who make it a part of their business to breed horses. We know nothing about the profits of the business, but we know very well that if it pays to raise a horse that at four or five years old can scarcely be sold for \$100, it will pay to raise one that will sell readily at the same age for twice that amount. With a good stock on hand, it is much easier and cheaper to raise a good horse than a bad one. The improved system of farming which is now being put in practice will require better horses, and farmers will find out soon that it will be much better to have one span of horses than two. How common it is every where to see four horses performing *badly* what two ought to do *well*. The time is at hand when the farmer will consider it economy to give \$400 for a pair of horses, instead of \$200. Farm carts will soon be introduced extensively; and with them a good, heavy, active horse, will do more work in a day than a yoke of oxen in two; but a light legged horse is of no use in a cart.

Much can be done to improve our present race of horses, by judicious breeding. Place a mare having some desirable points with a horse whose prominent developments are such as, combined with the good parts of the mare, you wish to obtain in the foal;

and in this way, if the mare is not too old, and is kept warm and comfortable during winter, doing little work, and the foal be never starved when young, a horse may be expected that will amply pay for the extra expense and trouble, costing no more to keep than one not capable of doing half the work.

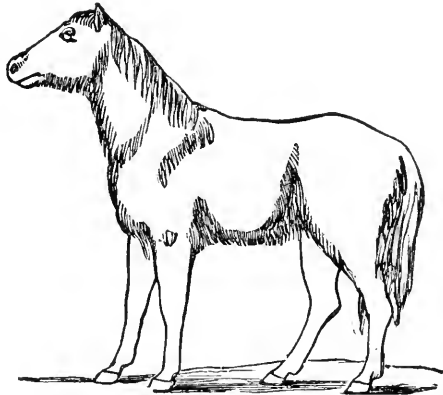

OUTLINE OF THE WILD TARTARIAN HORSE.

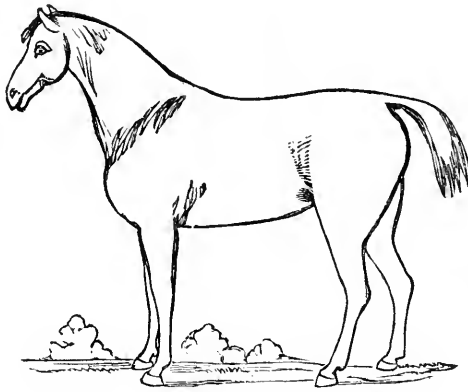

OUTLINE OF THE MODERN HUNTER.

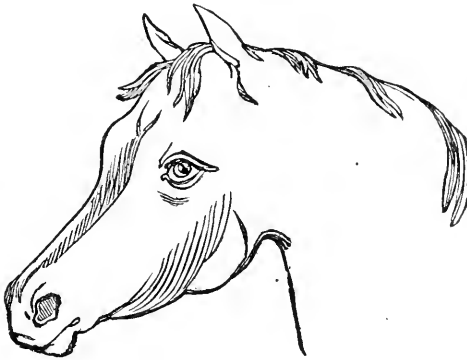

OUTLINE OF THE HEAD OF THE ARABIAN HORSE.

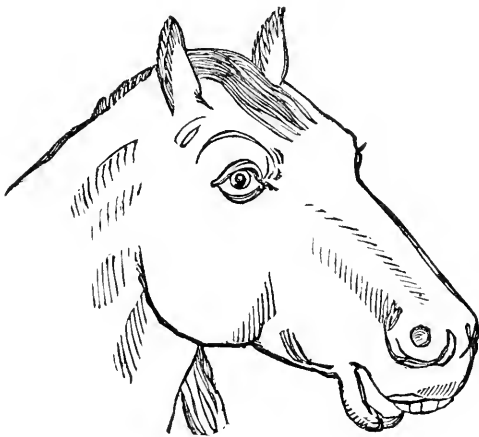

OUTLINE OF THE HEAD OF THE HUNGARIAN HORSE.

The power which man possesses to improve different races of animals, is well illustrated by the difference between a wild Tartarian horse and a modern English Hunter, or the horse as he was and as he is. The large, heavy head, angular bones, rough and shaggy coat, and coarse, heavy legs, have given place to a graceful form, small intelligent head, arched neck, slanting shoulder, clean and nimble legs, showing that mind has been at work moulding the plastic frame which nature has given, into one better fitted for the requirements of man. Further: an Arabian horse, brought up amidst and treated as one of the family, the instincts of attention and understanding daily cultivated and strengthened; exhibits a head which for intelligence and beauty is unequalled: while the Hungarian horse, removed from man's sympathy and care, has a heavy, sullen, unimpassioned head, in every way the contrast of the intelligence seen in the Arab's. This is accomplished—not in a day; but is the work of ages. Yet, when a superior breed is obtained, nothing is easier than to perpetuate or improve it, no fact being better established than that the offspring inherits the form and peculiarities of *both* parents. In this fact lies the grand means of improving not only our present breeds of horses, but of all farm stock.

The object of these remarks is to introduce a notice of the finest specimen of an agricultural horse that the world can produce at the present time. The Suffolk horse, or "Suffolk punch," has long been celebrated in Norfolk and Suffolk, the finest agricultural districts in England. The breed we believe is no longer in its purity, having been greatly changed by crossing; yet at this day they have no equal. We had the pleasure of seeing the magnificent display at the great Windsor show last summer, and no animals on the ground interested us so much as these noble Suffolk horses. A prize of £30

(£150) was offered for "the best stallion of any age for agricultural purposes," and this

horse took the prize in a competition never before equalled in England, or perhaps in the world. Look at his compact, strong, and yet graceful form. There is nothing of your stupid, clumsy "Samson" about him. His movements are as active and graceful as a "full blood," yet his deep shoulders are made for the draught. It is said in Eng-

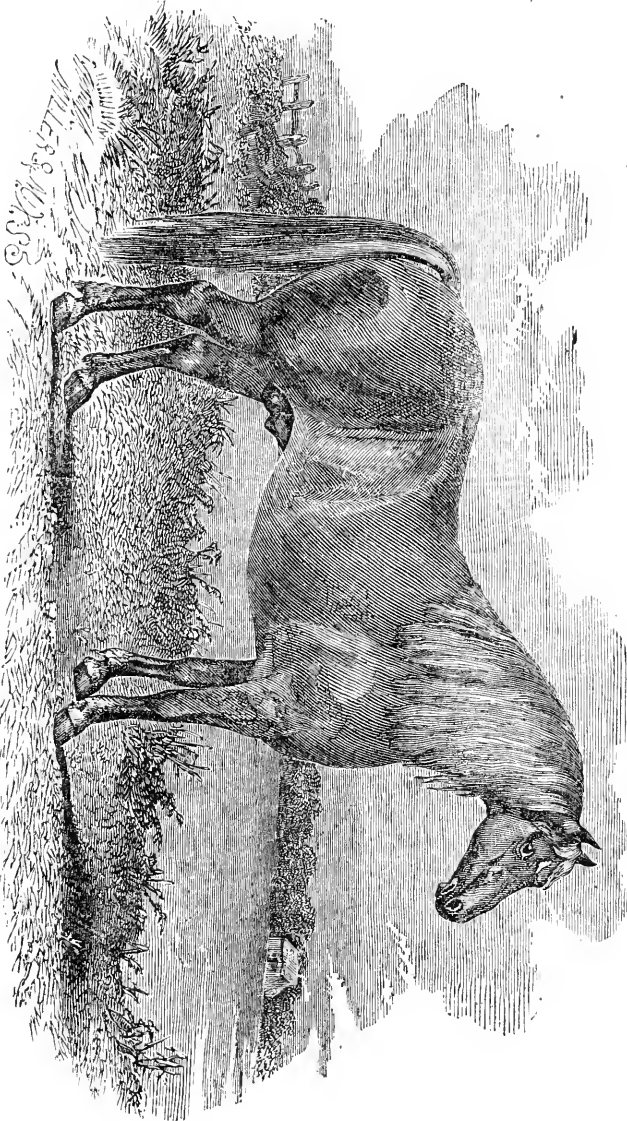

A SUFFOLK STALLION.

THE PROPERTY OF MR. THOS. CATLIN, OF HUTLEY, NEAR WOODBRIDGE, SUFFOLK, FOR WHICH THE FIRST PRIZE OF £30 WAS AWARDED AT THE MEETING OF THE ROYAL AG. SOCIETY OF ENGLAND, HELD AT WINDSOR, JULY, 1861.

land that a Suffolk team will do a greater day's plowing, and return home in better condition at night, than any other of the powerful English farm horses. Some very injudicious importations of horses have been made to this country. Will not some of our horse men import this stock? They would confer great benefits on the country by so doing.

Horticultural Department.

CONDUCTED BY P. BARRY.

FRUIT ROOMS.

EVERY year's experience adds importance to the inquiry concerning the structure of fruit rooms. The extensive cultivation of the pear gives it special interest at this time, for pears can not be so safely kept in cold cellars as apples. But we have reason to believe that large quantities of apples are annually lost by bad keeping. Cellars under dwellings are generally damp to some degree, and warm, besides being occupied with vegetables and other articles that communicate impurities to the atmosphere, and affect the flavor if not hasten the decay of fruits.

The winter of 1850-51 was somewhat unusually mild, and people complained in all directions that their fruit "never kept so badly." The past winter has been remarkably cold, and we hear it said all around that "fruits keep unusually well." We know this to be the case. We had brought us early in the winter, by a friend, a barrel of favorite apples in a very bad condition, apparently in a half decayed state. We concluded they were not worth attention, and left them headed up in a dry, cool room, where the thermometer was seldom more than two or three degrees above the freezing point. We opened the barrel two months afterwards, and found they had made not the least progress in decay—the cold completely arrested it. In the same room, we have several barrels of sound apples, placed there in November; and on examination now, in March, are so perfect that not half a dozen specks, indicating decay, are found in a barrel. The same varieties in a warm cellar have decayed much. We have even been able to keep autumn apples and pears sound till February, in consequence of the dry and excessive cold winter. This affords indications that may be turned to good account, viz: that a low, steady temperature, with dry atmosphere, are the chief requisites for a fruit room.

In a late number of the English Gardeners' Chronicle, Mr. ROBERT THOMPSON gives the following description and plans of the fruit room of a gentleman near London, who has for several years exhibited pears in fine condition at a season when the same varieties are generally gone. It illustrates the leading principles to be observed in building a fruit room; but it must be remembered that in our northern States at least, greater precautions must be taken to prevent freezing. Thick walls with air spaces, or filled with some non-conducting material, and thick floors, &c., are among the essentials in this regard. The Hon. M. P. WILDER, of Boston, writes in the Horticulturist—

My fruits are keeping admirably in the new fruit room. This room happens to have been situated and constructed so much like Mr. MORRISON'S, (of which you have seen the drawings and description in the Gardeners' Chronicle,) as to be almost a fac-simile of his. The walls of mine, however, are filled in with charcoal and sawdust.

The *Beurre Diel*, *Vicar of Winkfield*, *Excellentissima*, and other autumn pears, are now in as perfect condition as when gathered from the trees, and so they will remain till the warm weather of spring approaches. I shall then try some of them in the non-conducting boxes, where I think they may be kept till summer. I have by a similar process, preserved some varieties till July. Mr. MORRISON has no new principle. All that is necessary is to obtain a low temperature during the warm weather of autumn, and to preserve this equilibrium. This being attained, there is no difficulty whatever. When the severe weather of last month occurred, my fruits were removed from the shelves and packed in boxes, with a thin layer of clean rye straw between each tier, the tubes of the straw containing air enough to correct mildew and damp. The boxes are now piled on one side of the room, and covered with hay about three feet in depth.

My experiment was suggested by the bad effects of moisture and warmth in my old fruit cellars, under my dwelling house, and the same difficulty exists with rooms on the ground floor of buildings. I therefore resorted to the other extreme—a cool and dry chamber on the north end of my barn, the location of which you know, (and like Mr. MORRISON'S,) over the carriage room. I am now quite

satisfied that we have at last ascertained the proper location for a fruit room; namely, a cool upper apartment, with lined non-conducting walls. M. P. W.

DESCRIPTION AND PLANS OF MR. MOORMAN'S FRUIT ROOM.—The room was not originally constructed for a fruit room; but, by a little adaptation, Mr. MOORMAN has succeeded in rendering it a most excellent one, as is proved by the prizes awarded for the productions exhibited from it,—not in any one year, but repeatedly, year after year. It is a partitioned-off portion of a loft which extends over a coach-house and stables, and is that part which is above the coach-house. It was originally fitted up for a harness room, the walls, as is usual in such places, being lined with wood. The roof is slated. The range of building is detached, and faces the southwest.

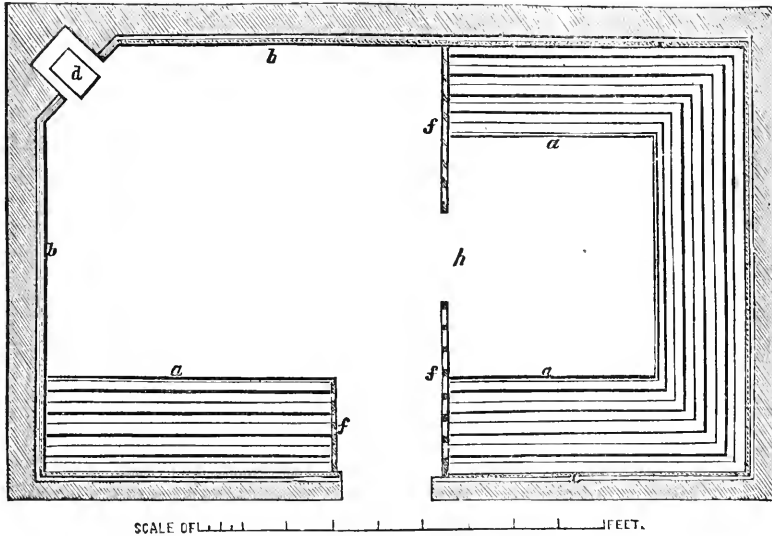

Fig. 1. PLAN OF MR. MOORMAN'S FRUIT ROOM.

It will be observed that there is a cavity, *c*, between the boarding and walls. This, I believe, is an important circumstance, and so is the wooden lining, because air and wood are known to be slow conductors of heat. The ceiling, on the north side is double, and the floor is wood above a ceiling. We may therefore conclude that a uniformity of temperature in the interior of the room is insured to a considerable extent. There is a small stove, *d*, but it is seldom used, and never with the view of warming the air of the room, unless the temperature is actually below freezing. The fruit is therefore kept cool. The swing-window, *e*, is occasionally a little opened; but it is at all times covered with a roller-blind, so that the fruit is kept in the dark. A little fire in the stove, air being freely admitted by the window at the same time in a dry day, is useful for speedily removing any damp which may arise from the fruit. The shelves, *a, a*, have a layer of clean-drawn straw laid across them; on this the fruit is placed singly.

From a consideration of all the above details it may be inferred, that if a fruit room be built over a place where there is a free circulation of air, its roof double ceiled, the walls lined with wood, a cavity being left between these two, it will possess the essential properties of the one under consideration.

The more important principles necessary to attend to, with regard to the long keeping of fruit, are

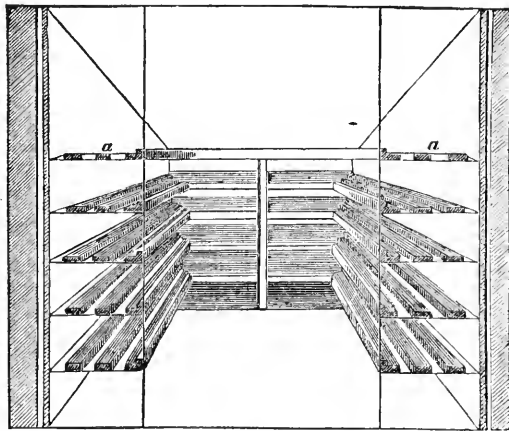

Fig. 2. INTERIOR VIEW.

uniformity of temperature, coolness, and darkness. If the temperature is uniform, there can be little or no deposition of moisture on the surface of the fruit; but if the air of the room should be, say 10 degrees warmer than the fruit, then the relative coldness of the latter will cause a condensation of the moisture contained in the air in contact with the fruit, just as a cold glass becomes dewed over when brought into a warm atmosphere. If the air is indeed very dry, then a proportionately greater

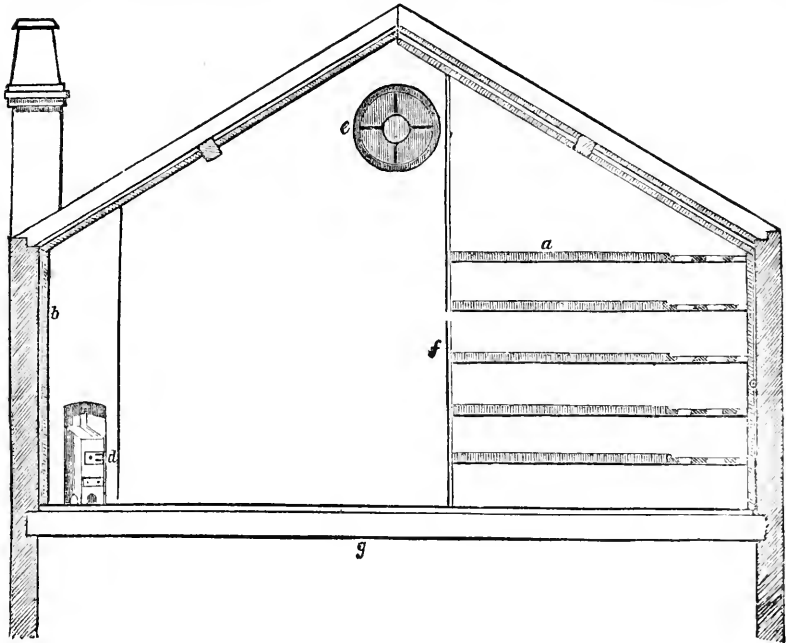

Fig. 3. LONGITUDINAL SECTION.

Explanation of the letters.—*a*, Shelves made with battens, $1\frac{1}{2}$ inch wide and $1\frac{1}{2}$ inch apart. *b*, Close boarding around the sides of the room. *c*, Air space between the boards and the wall. The roof has also an air space on the north side between the two plaster ceilings, as shown on the section. *d*, Stove. *e*, Circular window hung on pivots, and fitted with a roller-blind. *f*, Partitions of open work similar to the shelves. *g*, Coach-house under fruit room.

difference of temperature is necessary to produce the above effect; but in winter the hygrometer seldom requires to be cooled more than a few degrees before it indicates a deposition of moisture. Fruits with smooth, glossy skins, in close contact with the cold substance beneath them, are those most profusely covered with moisture from the above cause. In russeted varieties, their dry, rough coats serve as non-conductors of heat, and hence less moisture is deposited on them. When the air becomes colder than the fruit, a contrary action—that of evaporation takes place, and the surface of the fruit becomes dry. But this wetting and drying must prove very injurious; while its cause, alternations of temperature, must likewise affect the specific gravity of the juices of the fruit. Mr. MOORMAN'S fruit is not exposed to such vicissitudes; for when the weather becomes frosty, it is several days before the thermometer in his fruit room is affected as much as one degree.

It may be remarked that, in giving air, a period of the day should be chosen when the thermometer outside indicates the same temperature as that in the room. No deposition of moisture can then take place in consequence.

With regard to coolness, it is well known that this condition is favorable to the long-keeping of fruit; for we act on the contrary when we wish to render any variety fit for use before its usual time. The fruit room in question must be cooler on an average, than if it had been on the ground; for the latter, under a building particularly, is much warmer than the air in winter.

Light accelerates the maturity and ultimate decay of fruit exposed to its influence. If the soundest specimens are picked and placed opposite a window, they soon become much inferior in appearance, compared with those from which the light is excluded, all other circumstances being the same. In Mr. MOORMAN'S fruit room, the light is excluded by a blind, even when air is given.

By such arrangements as those above detailed, Mr. MOORMAN keeps the *Marie Louise* in fine condition till after Christmas. He possesses a selection of the best varieties of pears, which he grows chiefly on espaliers, which are well managed by his gardener, Mr. TUCKER, in the Clapham-road. He had some remarkably handsome specimens of the *Winter Nelis* in his fruit room in January, much larger

than that excellent variety usually grows. We have also seen very large specimens of the *Marie Louise*, grown at his seat at Box Hill, in Sussex. The tree which produced them is trained against the gable end of a barn, about a quarter of a mile from the sea, and this tree is exposed to the strong sea-breezes from the southwest. It was planted in good soil, and a spring below it was discovered when digging the hole for the compost, previous to the tree being planted.

HINTS FOR THE SEASON.

APRIL, throughout a large portion of the country, is the busy month of horticulture. *Grafting* may be continued, especially of apples and pears, until the leaves begin to expand, if the scions have been cut in season and properly kept. Cherries and plums should have been done last month.

Transplanting may be continued as long as trees may be obtained in good order. It often happens that persons residing in the south and west can not obtain their trees from the north until the planting season is past with them; but as long as the trees to be planted are in a dormant state, planting is safe. We plant trees successfully here as late as June, when they have been retarded by being kept out of the ground a long time, as when imported. The month of May is the best time in the year to plant evergreens.

Dahlias, and all *bedding plants*, are best put out about the latter end of May; all danger of frosts is then over, and vegetation proceeds rapidly and safely. We do quite as well with dahlias put out in June; they come into bloom at a favorable time, when the hottest weather is over. We intend to give a few hints on their management next month.

Annual Flower Seeds, where to be sown in the open border, should not be done until the weather is steadily fine, and the ground dry and warm. The soil should be made as fine as possible, as the seeds are generally small and the plants delicate. The covering is an important point; it should be very light and even. A very thin coat of fine moss aids in preserving a uniform degree of heat and moisture. Transplanting annuals, either from hot beds or from the open border, should if possible be done on a moist or cloudy day; and if the sun comes out strong immediately, a slight shade should be given. In cases of drouth, watering should be well attended to. Where seed beds are watered, a finely pierced rose should be put on the spout of the watering pot, that the water may fall like a gentle rain, and not disturb the earth or seeds.

Lawns, Edgings, Walks, &c., will require a dressing. A little attention now to existing defects will give satisfaction during the whole season. Ornamental shrubs or trees requiring a slight pruning to put them in good shape, should receive it now; and all climbing roses, and other plants, be neatly adjusted on their supports.

The Kitchen Garden, if looked to for a constant and liberal supply of vegetables, must receive due attention. It happens frequently with the farmer, that his kitchen garden is neglected until the press of farm work is over, and then it can only yield a few of the common vegetables about mid-summer. How cheap the Farmer can have *radishes, lettuce, green peas, beans, asparagus, cabbages, cauliflower*, and the other luxuries that people in the city get so poor and pay so dearly for. Begin now; take the warmest and dryest border facing south for your early crops. Lettuce, peas, beans, potatoes, &c., can be planted any moment, and may have been long ago. Plant few at a time, and keep up the succession. Such articles as radishes, lettuce, and green peas, may be on the table all summer, if desired. It would certainly pay every farmer who has a large family, to keep one man most of the time in the garden; unless during haying and harvesting, when he might turn out. There is economy, to say nothing of the comfort, in keeping the table well supplied from the garden. *Bris's* book on the "Kitchen Garden" will be a great aid to those who do not keep a gardener.

Before closing our brief chapter of hints, intended merely to refresh the memory, we must say a word about *liquid manure*. This should be considered as an indispensable article in every garden. The drainage of the stables may be saved, or the liquid may be made in a barrel or tank with rain water and manure. All growing crops in the kitchen garden should be freely supplied two or three times a week; it forces their growth, and makes them tender and succulent. Strawberries, just after the fruit is set and until it begins to ripen, will be greatly benefitted by an application two or three times a week. The great advantage of liquid manure, and what makes it act upon plants like a "charm," is that it is in a fit state to be immediately appropriated by them. Solid manures have to remain in the ground long enough to be dissolved.

Insects require constant watching. *Caterpillars* on the apple trees; the *curculio* on the plums, apricots, and nectarines; the *aphis* on the foliage of various kinds of trees; the *peach worm*, or *borer*, and the various other insects that prey upon trees and plants; come forth at their appointed time: and to repel them promptly must be as much the business of the cultivator now, as to sow his seeds or plant his trees.

THE CANDYTUFT.

THE *Purple Candytuft*, an engraving of which we give, is an annual plant, growing to the height of about a foot, with spreading branches and large heads of purple flowers. The species is a native of Candia, and seeds were taken to England about the year 1590.



PURPLE CANDYTUFT.

From that time it has been a general favorite in British gardens, and should be grown by all lovers of flowers, for its beauty and easy culture. It grows well on almost any rich soil, if not too moist; and as it will not bear transplanting well, it should be sown where it is to remain. Sow from the 1st to the 15th of May. Superior flowers will be obtained by soaking the ground occasionally with liquid manure, readily obtained by placing the cleanings of the fowl-house in a barrel with water, and keeping on hand a constant supply. When the plants are going into flower the heads should be examined; and if too numerous, they should be removed. By this treatment, and occasionally loosening the ground around the plants, and keeping it free from weeds, flowers have been grown three inches across, most beautifully colored, being of a very dark purple on the outside, and softening to nearly white in the center. The great points are thinning the flowers gradually as they increase in size, and supplying their roots with abundance of rich food when they are going into flower. By this mode of treatment much finer flowers may be grown than those usually seen in our gardens.

The *Rocket Candytuft* is a splendid variety, growing two feet high, branching widely, each plant producing three to five racemes of flowers from six to ten inches long, and the center one even longer than this, if properly cultivated. Cultivation the same as the *Purple*.

Editor's Table.

FLOWER SEEDS.—Our applications for flower seeds now count up more than four thousand, and every one will be sent previous to the 5th of April. Some apply for double dahlias, verbenas, and other plants that are not propagated from seed, but from bulbs and cuttings, which it will be impossible for us to send. The following persons have made application for packages of seeds, without giving in their Post office address: Mrs. A. S. Manly, Mary Coon, Clarinda R. Sanders, Mrs. D. L. Ackerman, J. L. Anderson, A. M. Mc Fatridge, C. Wire, Mary C. Saunders, Louisa Luce, Mrs. D. Bouck. These will have to send again, giving us the name of Post office and State.

If any of our brethren of the Agricultural Press wish to engage the services of an editor who is a good practical farmer, and thorough chemist, well acquainted with the best systems of agriculture in this country and in Europe, and who for several years assisted Messrs. LAWES and GILBERT in their invaluable experiments, they will please write us on the subject.

CLOTH FOR HOT-BEDS.—I see in your March number of the *Farmer*, that you say you can not speak favorably of cloth as a substitute for glass in hot-beds. You don't say why it is not successful. I used both the cloth and glass last season, and found in many respects the cloth was far superior to glass; so much so, that I shall this season wholly discard glass, and use the cloth instead. SYLVESTER LORD.—*Medusa, N. Y.*

Necessary absence about the time our hot-beds should have been in perfection, prevented our testing the matter personally as we intended to do, and consequently we had to rely on the statement of those to whose care they were committed. We are gratified at the statement of Mr. L.

Inquiries and Answers.

(John B. Jones, Patterson.) **CARROTS.**—We know of no better manure for carrots than well rotted barnyard manure. 300 lbs. per acre of superphosphate of lime may be added with profit. Four pounds of seed per acre is sufficient. It should be sown in rows about one foot apart, as it is then much easier to keep the land clean. The superphosphate of lime should be placed as near the seed as possible.

(W. V. Morse, Hayfield, Craw. Co., Pa.) We believe there is no cure for horses that have the heaves badly; but much may be done to relieve them by judicious management and feeding. The horse affected should never be worked hard on a

full stomach, nor allowed to drink large quantities of water at once. Dusty clover or hay is very injurious. Good clean timothy, cut fine and moistened with water, and if convenient, mixed with shorts or bran, is the best food. Equal parts by weight, of sulphur, saltpetre, antimony, and liquorice powder, mixed together, is a good cordial medicine for such horses in the spring. A table spoonful should be given in moistened shorts twice a week.

AMMONIA.—Can you inform me how to manufacture ammonia? I have read in some book, that large quantities have been manufactured in England by the use of common salt; but that the duty on this article is so high there, that the manufacture has been abandoned. T. H.—*L. Island.*

We believe there is now no duty on salt in England, and *muriate of ammonia* is, extensively made; but the impure article used for agricultural purposes sells for \$100 per ton, and though it greatly increases the produce of wheat, yet at the present price of wheat it does not pay to apply it. The cheapest method of obtaining ammonia, is by growing green crops extensively and consuming them with cattle or sheep, giving them oil-cake or other rich nitrogenous food.

COAL TAR.—Will coal tar at \$2.50 per barrel preserve shingles enough to pay the cost of painting them with it? Will the building be more likely to take fire with it on the roof? How would you apply it? I am altogether unacquainted with it, but have heard it would be beneficial if applied. A. KENT.

We know of no substance so cheap and so beneficial to preserve wood of all kinds, as coal tar. Have never seen shingles painted with it, but think it would render them more durable. They are themselves highly inflammable, and a coat of coal tar would rather diminish than increase their liability to take fire. It could be applied with a common white-wash brush. Gates and board fences, barns, out-houses, &c., would be greatly benefited by an application.

ONIONS.—We have received many valuable communications in answer to the inquiry of S. A. D. T. K. in the February number, from which we give extracts that will be found interesting.

"The ground best adapted for the growth of onions is what is generally termed a good wheat soil. The year previous to sowing onions, I plow the land deep; manure well with horse dung, and plant to potatoes or corn. After the crop is off in the fall, yard sheep on the land, removing them before feeding hay in the spring. I stir the surface of the ground only with a cultivator, and sow the seed as early as the soil will admit. In

raising the black seed or common onion, I sow in drills 13 or 14 inches apart, sowing four times as much seed as I intend to have remain should it all grow. When of sufficient size to weed, I use the hoe, and the drills being straight allow me to cut close, leaving but little to weed by hand. Where I find them too thick I cut them out with a sharp hoe, about five inches apart, leaving five plants in a hill. Where there are any missing, I transplant. In this way I usually obtain good crops. Last year I had 281½ bu. from 45 rods of ground treated in this way. G. N. HATHAWLEY.—*West Potsdam, N. Y.*

"TOP ONIONS.—I always place my top onions in the ground as soon in the spring as I can get them in—sometimes in March, but always as early as April. Those intended for raising seed should be set deeper in the ground than those for bottoms. The largest seedlings will raise seed. I cultivate for seed, therefore break no tops. I save my old onions, which are sound, to re-plant in the spring. I have had good success in keeping, as follows:—The seed will do to cut from the stalk when the stalk begins to dry up, which will be generally the last of July or first of August. The seeds are laid in a dry, airy place. The bottoms are left—those I use for seed—till the last of August or first of September. They are then taken up and dried in the sun a day or two, and are then removed to a dry place. When winter is about to set in, I put them all in old sacks or bags, from a bushel to a bushel and a half in a bag, after looking them over carefully and putting up none but sound. I then place these bags in my chamber, over my kitchen, and hang them up. I sometimes keep the bottoms in my cellar, but it requires more care. There is no fire in the chamber, but the heat from below. It will not spoil them to freeze, although I prefer not to have them, but keep them dry and cool. A. S. MOSS.—*Fredonia, N. Y.*"

"I shall not undertake to answer strictly the inquiries contained in your February number, but will give some of the experience of twenty-five years practice in raising from 1000 to 2000 bushels of onions each year, without ever failing for the last twenty years. There are three important considerations to ensure a large crop of onions:

- 1st. Rich land, well prepared with fine manure.
- 2d. Sow the seed early, if possible the first time the land is dry enough after the snow is off in the spring, in rows 14 or 16 inches apart.
- 3d. Thin out to 1½ inches in the rows, and to be kept free from weeds.

The general cause of failure is late sowing; onions will not bottom unless sowed early; those sown early will never fail to be proper onions, but the size will depend on the quality of the land and the manner of tilling. Some are yet of the opinion that the only certain way to ensure a crop of onions, is to raise from sets; this is a mistake. The experience of the last ten years has shown that the quantity of onion seed used, in proportion to other seed, has five times doubled in sections (particularly at the south) where the idea has been prevalent that onions could not be raised from the seed the first year, which is altogether erroneous. WM. RISLEY.—*Fredonia, N. Y.*"

TO KILL WHITE BIRCHES.—As there has been inquiry made as to the best mode of killing White Birch, I would say in reply, cut them in the spring before the leaves start; cut the stumps two or three feet from the ground and it will be sure death. Some may object to cutting them so high up, but if cut close to the ground, there will start fifty from one. The stumps will rot in one year. E. P.—*Rose, N. Y.*

ICE HOUSES.—I want to erect myself an Ice House during the ensuing summer, so it may be ready to fill next winter. I would be pleased to be informed by some of your numerous correspondents the best mode to erect one, as a building of this kind with us is quite a novelty. Cannot it be filled in cold freezing weather by letting a small stream of water run in at the top of the building from my water-fountain, which is high enough to let it in at the top. S. JONX.—*Mount Comfort, Pa.*

DAIRY HOUSE.—I design building a Milk or Dairy house—should I put it two, three, four, or five feet below the surface of the earth? Should I have a flag-stone floor? Can I have too much ventilation on the north side? Should I have more than half as much on the south side as on the north, and should those windows be near the top of the room for the warmed air to pass off? Should the sides, or the south side, be filled in between the siding and inside plastering with tan bark, or not? Should the space between the roof and inside of the rafters be filled with tan bark? In fine, do give us a good plan for a Dairy House—practical, plain, and not too costly. I have never seen a very large number, but I have never seen a good one. E. H.—*Manorkill, N. Y.*

HORTICULTURAL

(J. D. V., Benton, N. Y.) APPLES.—Your specimens came to hand somewhat damaged, but it is a tender, juicy, sweet fruit—as good as any of its season—and if a good grower and bearer, worthy of cultivation. Send us a couple of grafts in a letter.

(W. J. B., Grand Rapids, Mich.) You can procure Horse Chestnuts of the seedsmen, in the Autumn, at about \$5 per barrel, perhaps less. Sow in drills four inches apart, cover three inches deep, and when they have grown one or two years, transplant into nursery rows.

(W. S. H., Ballston Spa.) We are not aware of the *Sarracenia* being cultivated in gardens successfully. It would require low, marshy ground. It is, as you remark, "a curious and elegant plant," better appreciated abroad than at home. Thousands are annually sent to Europe.

The best book on general floriculture is BRECK'S; the best special, rose treatise, is PARSONS'. We cannot answer as to "what rose bears the highest reputation." It depends upon the character desired. *La Reine*, Hybrid Perpetual; *Souvenir de la Malmaison*, Bourbon; *Cloth of Gold*, Noisette; *Devoniensis*, Tea; are all celebrated and fine roses of their respective classes.

(J. M., Albion, Iowa.) We fear you will never succeed in growing peaches on your rich, deep, black loamy soil—"two to three feet deep in a

clay subsoil." As you remark, the trees grow too rank, and too late in the fall. You must have dry, gravelly, or sandy upland. It might be well to put a bed of stones and gravel under each tree, and mix sand and gravel with the soil about the roots; work them also on plum stocks.

(A Subscriber.) In grafting the limbs of large trees, it is neither necessary nor proper to cut them back to the trunk, but merely so far as will bring the new shoots at a proper distance from one another to make a good shaped head.

(M. H. H., Perry, Wyoming Co., N. Y.) Neither the *Chromatella* Rose, nor *Double White Althea*, are hardy enough to bear our winters unprotected. A slight covering of straw protects them. All the other Altheas are hardy enough.

(T. K., Cavan, C. W.) Pears on quince stocks succeed well on all good soils. A deep, dry loam is best; gravelly soil should be avoided. The quince itself succeeds as well, and better, on a dry soil than a moist one, provided it be deep and good. The cold vinery will be forthcoming soon.

(J. H., Newstead, Erie Co., N. Y.) SUBSOIL PLOWS.—We use the No. 1 Subsoil Plow made by Ruggles, Nourse & Mason. In clear land without stones, two horses, following the common plow, will pulverize the bottom eight or ten inches deep; if stony or gravelly, four horses will be required. For very heavy work, we would recommend No. 2 of the same make.

PLANTING TREES IN A WHEAT FIELD.—If you do this, you must keep a clear space of at least six or eight feet all around the trees, or they will be ruined.

(Mrs. J. H. W., Whitesboro.) The green insects on your roses are *aphides*, easily killed on your house plants with tobacco smoke, and on the garden plants with a mixture of soap suds and tobacco juice thrown freely over them with a syringe, or by dipping in the branches.

(J. W. C., Bull's Pond.) The *Northern Spy* fully sustains its high character here. We do not hesitate to call it the *best* of all long keepers.

(H. K. E., Rockford, Ills.) We refer you to the Nurserymen's advertisements; any of them will send you a catalogue.

The Osage Orange is easily grown. You can get seed of any seedsman at 75 cts. to \$1 per quart, and young plants from the nurserymen at \$10 per 1000. Sow the seed as you would peas. The plants are set in a row, for a hedge, six inches apart, in good, clean, well prepared soil. We will be thankful for any information in regard to your section.

(H. C., Huron, N. Y.) You can use either the

English or American Thorn for stocks for the pear. Paradise stocks, and dwarf Apple trees, may be had at any of the nurseries. See advertisements.

(A. V. B., New Paris, Ky.) The seeds will be sent. Enclose us a few melon seeds in a letter, by mail.

(P. F. E., Cross Keys, Va.) We cannot recommend you a cure for "bitter rot." It prevails in certain localities, and in some varieties more than others. Renew your stock from the north, and plant on *dry* soils.

(D. S., McGillivray.) You will find a recipe for grafting composition in back numbers of the Farmer. Rosin, beeswax, and tallow, in equal parts, melted together and well worked, answers very well. See Hints for this month.

(M. C. W., Chagrin Falls, O.) Follow up the tobacco solution and it will destroy the insects you allude to effectually. White-washing is of no use, as it is the leaves they feed on.

(J. L. E., Mexico.) It is not good to plant trees on green sward; but if you must do it, dig and pulverize well a space four or five feet in diameter around each tree. Plowing ridges six feet wide, for each row, would answer. Keep the ground clean about the trees all summer.

(A. T., Amboy, Ohio.) *Howe's Seedling* strawberry can be procured of any nurseryman, at about \$2 per 100.

(Subscriber, Rushville, N. Y.) The ground, for hedge plants, should be well plowed or trenched, in as good order as for corn. You can set the row a foot from the stone wall. We would recommend you Buckthorn, as we are not sure that the Osage Orange will be perfectly hardy. We think it will, as our hedge now looks well after the hard winter.

J. H. L., East Charlemont, Mass., inquires if any of our correspondents know of any method of preserving trees that have been girdled. We know of none.

(T. N. M., Canandaigua.) Some of your seeds may come up this season, but it is doubtful. They were either too old, or some way mismanaged.

(S. E. P., Potter's Hollow.) Use lime water. If badly infested, re-pot with fresh earth.

(J. H. C., Springport.) You can graft the Grape Vine before it begins to grow. Cut off the stock level with the ground, and cleft-graft as you would an apple tree; when the scion is secured, draw up the earth around it, leaving out one bud. The best way to protect tender sorts is to lay down the vine in the beginning of winter and cover with a few inches of earth.

(B. P. C., Pleasant Mount, Pa.) You can graft your *Mazzard* stocks, but it is now too late, so you had better bud them in August. If small, say not over half an inch in diameter, put in one bud within three or four inches of the ground; if large, bud the branches.

(S. G. M.) PRAIRIE RAIL TIMBER.—We recommend you the yellow locust. Raise the plants from seed; transplant at one year old, and in five or six years you will have rail timber. You can get seed at the seed stores generally. The European Larch is a rapid growing tree, worthy your attention. You can get seeds or plants, through the nurserymen.

(R. W., Macedon.) The best work on the indigenous Flora, is Gray's Genera of the Plants of the United States, 2 vols., beautifully illustrated.—Gray's Botanical Text Book is a smaller and cheaper work, and affords considerable information.

(H. L., Pleasantville, N. Y.) The Azalea is propagated by cuttings of young wood put in a mixture of sand and peat, and covered with a bell glass until rooted. It is also propagated by layers, and this is the easier way for you; put out the plants in a peaty border, and layer in the usual way, in July.

All communications, inquiries, &c., should be sent in not later than the 10th of the month, in order to receive attention in the following month's paper.

WILLOWS.—Permit me, as a subscriber to the Farmer, to make a few inquiries relative to the Willow. In a number of the State Register, under date of March 8th, is quite a lengthy article from the Philadelphia North American, describing three varieties—*Salix Viminalis*, *Salix Caprea*, and *Salix Alba*.

Where can the two first named varieties be found? What is the best manner of cultivating? What kind of soil is best adapted? and will it grow upon any soil? What is the usual and best way of cleaning the bark off the wood, and preparing for market?

A gentleman by the name of W. G. Haynes, a resident of this State, has grown some, but I do not know his residence. Please inform me if you can.

The above, and any other matter of interest, touching growth, &c., of the Willow, you will, if possible, answer through your columns or by letter. DANIEL MORSE.—Lockport.

The *Viminalis*, which is the common English osier, is the best for basket work, though several others are used for that purpose. The above sort can be had in small quantities at least, in many of the nurseries.

The best soil for the willow is a deep, moist, loamy soil near water, along streams, margins of lakes, &c., &c. Gen. HARMON, of Wheatland, has given some attention to this subject, and will probably be kind enough to furnish some of the desired information from his experience.

To Farmers.

CANVASS and Oiled Cloth Stack covers on hand, or made to order.
E. C. WILLIAMS, AGENT,
Sail and Tent Maker, No. 12 Buffalo St., Rochester, N. Y.
April, 1852.

Peruvian Guano.

AND other Fertilizers. Several hundred tons of first quality of Peruvian Guano, constantly on hand for sale.
Also, Bone Dust, Plaster of Paris, and Poudrette.
A. B. ALLEN & CO.
April, 1852—If. 189 and 191 Water st., New York.

Manures.

PERUVIAN GUANO, Bone Dust, Pulverized Charcoal, Poudrette, Sugar, Wood's Renovating Salts, Potash, Sulphuric Acid, Plaster-house Scum, for sale in lots to suit purchasers.
LONGETT & GRIFFING,
[4-24] 25 Cliff Street, New York.

To Nurserymen.

A FEW Quarts of European Mountain Ash Seed, clean from pulp, and will be ready to sow from 1st April to 1st May. For sale by the subscribers, at the Geneva Nursery, at \$5 per quart.
W. T. & E. SMITH,
[4-18*] Geneva, N. Y.

Union Agricultural Warehouse and Seed Store.

RALPH & CO., No. 23 Fulton Street, New York, near Fulton Market, Dealers in all the most approved Agricultural and Horticultural Implements; Imported and American Field and Garden Seeds; Ornamental Shade and Fruit Trees; Guano; Bone Dust; Poudrette, &c. Wrought Iron Plows, Trucks, Barrows, &c., &c., always on hand. Also, the Excelsior, or California Plow. [3-31]

Tents! Tents!!

FOR SALE, to rent, or made to order, of any required dimensions. Agricultural Societies wishing to hire Tents the coming season, will please make early application, as by knowing early how many, and at what time they will be needed, I can make arrangements to supply all.

E. C. WILLIAMS, AGENT,
Sail and Tent Maker, No. 12 Buffalo St., Rochester, N. Y.
N. B.—Flags, National and Agricultural, with devices, or any other kind, made to order at short notice.
April, 1852.

Spring Wheat.

WE have just received by the first Boat from Canada—100 bu. of the celebrated Fife Wheat, which does not

- rust.
- 100 bu. Chb Wheat.
- 100 " Black Sea do. grown in this State.
- 100 " Italian Wheat.
- 25 " Spring Rye.

Farmers who are in want of a good article, will please give us a call, and get some of the right kind of seed, at the Genesee Seed Store, 63 and 65 Buffalo st., Rochester, N. Y.
April, 1852. J. RAPALJE & CO.

Plows! Plows!!!

WE are now getting in our spring supply of the celebrated Eagle Plows from Boston; also, the justly celebrated Curtis Plow, made by H. C. Curtis, Albion. These Plows stand unrivalled in this country, and are made expressly for use. They are made of superior timber, and the workmanship cannot be beat in this or any other country. All Plows sold by us are warranted to perform as recommended, or they may be returned and the money refunded.

J. RAPALJE & CO.,
Genesee Seed Store and Agricultural Warehouse, Rochester, N. Y.
March 1, 1852.

Cochin China and Shanghai Fowls for Sale.

THE subscriber has for sale a few pairs of his celebrated stock of *Cochin China* fowls, of his own importation, warranted true to their name and not excelled by any other stock in the country for good qualities. Also, a few pairs of the Marsh Stock of *Shanghai* and *Sumatra Game Fowls*. Reference given in regard to them, if desired.

EGGS FOR SETTING.

Eggs furnished from the above stock carefully packed for transportation, and orders for the same addressed to the subscriber will be promptly attended to. Price of Eggs \$2 per dozen.

[3-21]

CHARLES SAMPSON,
West Roxbury, Mass.

WRIGHT'S PREMIUM HORSE-HOE,
OR
Improved Shovel, Plow, and Cultivator,
Combined.

Application filed in the U. S. Patent Office.

TO the above was awarded the first premium at the New York State Fair held at Rochester in September, 1851. This Implement is so arranged that it can be used between rows of any width, from two to four feet apart, and can also be governed as to the depth, by raising or depressing the wings or hoes. The earth can be removed from the crop when small, or hilled up in its more forward state. In other words, the operator can perform all that is necessary to insure a good crop of corn, potatoes, &c., without the aid of hand hoeing, provided the directions which will accompany each Machine, are followed.

The main difficulty with all Corn Cultivators heretofore in use, is this: they do not perform enough to obviate the necessity of using the hand hoe two or three times during the season, which, to the farmer, is a very heavy expense, at a season of the year when labor is scarce and high. It is believed by the Inventor that this Implement will save the cost in hand hoeing on every 15 acres of corn or other hoed crops, and that the work can be done equal or better than twice hoeing by hand. Price \$10.

This Implement can be returned after one week's trial and money refunded, if not satisfactory.
Orders addressed to CASH & WRIGHT, Batavia, Genesee County, N. Y.

AGENTS.—E. Cash, South Byron, Gen. Co., N. Y.; Briggs & Brother, Rochester, N. Y.; G. Dodge & Co., Batavia, N. Y.; March & Brewster, Stafford; Bixby & Carpenter, Le Roy; G. F. Barnett & Co., Brockport; T. C. Curtis, Albion; W. K. Marvin, Lockport; John S. Wright, Emerald Grove, Wisconsin.

And will also be for sale in most of the principal cities and villages in Western New York.

April, 1852. CASH & WRIGHT.

Wood's Renovating Salts.

THE subscribers are now receiving large quantities of this valuable manure put up in barrels, which we will sell at one cent per lb.,—no charge for barrels.

This article is made from the following ingredients, viz.: Potash, Bone Dust, Bone Coal, Plaster, Glauber Salts, Saltpetre, Oil of Vitriol, Salts of Ammonia, Gas, Liquor, and Bullocks' Blood. For sale at the State Agricultural Warehouse, No. 25 Cliff street, New York.

LONGETT & GRIFFING.

We hereby certify, that our Renovating Salts are composed of the ingredients represented, and pledge ourselves to refund the money in all cases, to purchasers who can produce satisfactory proof to the contrary. Wood & Co. New York, March, 1, 1852. [4-21]

Stock Horses for Sale.

THE subscriber offers for sale his Stock Horses, "Hercules" and "Royal Britain." Hercules was sired by imported Alfred, dam by imported Sampson, g. dam by Blucher, g. g. dam by Whalebone. Hercules is four years past, color dark bay, heavy built, and weighed, in September last, 1550 lbs. He was awarded, at the State Fair held at Rochester, by the Committee on Draft Horses, the *Second Prize*.

Royal Britain was sired by Mr. Dickey's Sampson; he by Mr. Robinson's imported Sampson; Mr. Dickey's Sampson's dam, by imported Emigrant; Britain's dam, by imported Performer, color dark bay, with a small white star; weighed, in September last, 1310 lbs.

HIRAM HOSMER.

Bennington, Wyoming Co., N. Y. [4-16*]

Bone Dust.

BONE DUST, Coarse Turnings and Sawings, when taken in equal parts, price \$2.25 per bbl., including package.—This article is fresh, and warranted pure, from the Empire Mills. LONGETT & GRIFFING, [4-21] 25 Cliff Street, New York.

Field and Garden Seeds.

CLOVER, Large Clover, Timothy Seed, Blue Grass, Red Top, Ray Grass, White Clover, and Lucerne.

Garden Seeds.—Ruta Baga, Turnep, Cabbage, Beet, Carrot, Parsnep, Peas and Beans of every variety.

Fruit and Ornamental Trees.—Having been appointed agent for one of the best nurseries in the country, we are prepared to execute orders at short notice.

LONGETT & GRIFFING,

[4-21] 25 Cliff Street, New York,

A. FROST & CO.,
GENESEE VALLEY NURSERIES.
ROCHESTER, N. Y.

THE proprietors of these Nurseries solicit the attention of Nurserymen, Orchardists, Amateurs, and others intending to plant, to their large stock of Fruit and Ornamental Trees and Shrubs, which consists of a very extensive assortment and also being much superior in quality to any that they have before offered to the public, owing to their large importations from Europe and extensive home culture. Therefore, they can with confidence assert that whatever articles may be sent from their Nurseries will give universal satisfaction, and their prices having been much reduced they desire particular notice to them.

Articles furnished from their grounds will be ascertained to cost less received in much better condition, and consequently to give better satisfaction to the purchaser, than to obtain them of travelling agents.

All communications promptly noted.

For further description of their Fruits, Ornamental Trees and Shrubs, they refer to their *priced* descriptive catalogue, which may be obtained gratis, upon application.

Apple Trees—Strong and thrifty, 6 to 7 feet, comprising all the best varieties.

Pears—Standards of all the best sorts. Dwarf, trained as pyramids of one, two, and three, embracing over 75 of the most desirable kinds.

Cherries—5 to 7 feet, with fine heads, of 30 sorts most approved for cultivation. A quantity of an extra size can be furnished.

Peaches—of all the best sorts. Some extra size trees on hand.

Plums, Apricots, Nectarines, &c.—A fine collection.

Gooseberries—A large stock of superior plants, embracing 30 sorts of the best Lancashire varieties, best adapted for our climate.

Currants—Their collection of fine plants, and choice sorts of this valuable garden fruit, cannot be excelled—as follows: Cherry, May's Victoria, Red Grape, White Grape, Black Naples, Black English, White and Red Dutch.

Raspberries—Fastoff, Red and White Antwerp, Large Fruited, Monthly, and others.

Strawberries—of 15 best sorts.

Grapes—the native sorts—Isabella, Catawba, and Clinton.

Ornamental Trees—European Horse Chestnuts, Mountain Ash, Weeping Willow, and an assortment of our native trees American Weeping Willow, a new variety, very beautiful and distinct; English Weeping Ash; Golden twigged do.; Weeping Limes; European Larch; and others.

Ornamental Flowering Shrubs, &c.—Crataegus and Hibiscus in variety, Cydonia Japonica, Spiraea Douglasii and Prunifolia, Daphne Mezereum, Crataegus Pyracantha, Euonymus Americana, Weigela Rosea, Tree Paeonies 15 in. to 2 ft., and Purple Magnolias 4 ft.

Evergreen Trees, Shrubs, &c.—Norway Spruce, Balsam Fir, Pinus Sylvestris and Austrica, English and Irish Yews, Tree Box, and the Dwarf, for edging, Deodar Cedars 2 ft., Lebanon Cedars 2 ft., Cryptomeria Japonica 2 ft., Araucaria Imbricata 15 in., Forsythia Viridissima, Malva Aquifolia, and Magnolias which are very fine.

Standard Roses, 5 feet, and Dwarf Roses of the newest and best sorts, comprising Hybrid Perpetuals, Mosses, Bourbon, Teas, and Noisettes.

They will issue soon a catalogue of bedding plants, embracing a collection of new Dahlias, Verbenas, Petunias, Heliotropes, Fuchsias, Cinerarias, Antirrhinums, named sorts of Pansies, Salvias, Shrubby Calceolarias, Penstemons, and other valuable bedding plants that have just been imported.

The Dahlias embrace all the sorts of merit that appeared at the great Dahlia Show in England last season, which they have procured at a great expense.

April, 1852.

Peas! Peas!!

WE are now receiving by the first boat from Canada—1,000 bushels pure White Field Peas, such as Golden Vine, Creeper, White Canada, etc. 500 bushels White Marrowfat. 100 " Black Eyed do. 100 " Blue Prussian. 200 " Early Washington. 100 " Early Frame. 100 " Early Warwick.

Farmers who want good Peas at low prices, will please call at the Genesee Seed Store and Agricultural Warehouse, 63 and 65 Buffalo st. J. RAPALJE & CO. April, 1852.

NEW AND FINE SHRUBS AND PLANTS.

ELLWANGER & BARRY, Proprietors of the Mount Hope Nurseries, Rochester, N. Y., solicit the attention of those interested in Ornamental Plants to their large stock of rare and beautiful Shrubs and Plants, among which are the following:

HARDY SHRUBS.

Deutzia Scabra, or Garland Deutzia, a fine white flowering shrub.

Eusclytia Viridissima.

Ribes Gordoni—Gordon's Currant—yellow and crimson, very fine.

Spiraea Pinnatifida flore pleno—small, double, white flowers in great profusion; fine dense habit.

Spiraea Lanceolata, or Reevesi, one of the finest of the genus.

Spiraea Chamærifolia, *Niconderti*, *Lindleyana*, *Japonica*, and twenty others.

Spiræa (*Philadelphus*) *Pubescentis*, *Zepherii*, *Cordata*, *Double*, *Californiana*, and others, all fine.

Lonicera Ledibowri—a fine Californian shrub.

Tamarix, *Africana*, *Germanica*, *Gallica*, and *Lebanotica*.

Viburnum Lantanoïdes, a beautiful shrub.

Vibegta Rosea—the finest hardy shrub, lately introduced from China.

The above excellent things can be furnished in quantities, at low prices.

SELECT GREEN-HOUSE AND BEDDING PLANTS.

FICUSIAS.—Our collection is one of the best in America. The most distinct and best varieties yet introduced and quite rare, such as *Parvifolia*, *Fair Rosamond*, *Serratifolia*, *Serratifolia multiflora*, *Fulgens*, *Corymbiflora*, *Corymbiflora Alba*, *Magniflora*, *President*, *President*, *Peaches*, *Spectabilis*, &c., are propagated largely.

VERBENAS.—A collection of fifty varieties, comprising everything fine introduced to this time.

HELIOtropES.—*Souvenir de Liege*, *Corymbosum*, and some new varieties just received and to be announced hereafter.

PLUMBAGO LARPENTÆ.

CUPRESS.—*Platycentra*, *Stringulosa*, and others. The first is one of the finest bedding plants.

LANTANAS.—*Elegans*, the fine new Cincinnati variety, rose and straw color; *Mutabilis Major*, and several others.

BOUYARIAS.—*Triphylla*, and others.

ARCTILOSS.

SALVIAS.—*Splendens Major*, *Oppositifolia*, *Azurea*, and others—superb plants for masses.

FABIANA IMBRICATA.

HYDRANGEAS.—*Hortensis*, *Japonica*, *Cordata*, &c.

Buddlea Lindleyana—a fine shrubby plant with large clusters of purplish lilac flowers; blooms in the autumn.

HARBOETHAMNUS ELEGANS—a superb plant, half shrubby, with large clusters of showy crimson flowers; blooms equally well in the open ground in autumn, and in the house in winter.

PETUNIAS.—A large collection, embracing all distinct and good sorts.

LOBELIA FULGENS INSIGNIS, **LOBELIA FULGENS ALBA**—flowers of dazzling beauty—both new.

VERONICA LINDELYANA—a charming autumn flowering plant; long elegant spikes of pale (nearly white) blossoms. *Veronica Andersoni*—finest of all—new.

THREE VIOLETS—white and purple.

CHRYSANTHEMUMS.—A fine collection of the novel and beautiful pomponé or dwarf varieties.

DAHLIAS.—A superb collection, including the English and French prize sorts of 1851—all at very low rates.

CINCLEARIAS.—A fine collection of new and beautiful sorts, including *Magnificent*, *Attila*, *David Copperfield*, *Wilmington*, *Beauty of Newington*, &c. &c.

All the above articles furnished in large or small quantities, at low rates, and packed so as to go any distance with safety.

Priced Catalogues of Dahlias, &c. &c., ready 1st of March. March 1, 1852.

York County Farm for Sale.

ANY gentleman wishing to remove South, can be accommodated with a good Farm of 250 acres, about 70 acres open, level, abundance of mard, orchard and small dwelling, very healthy, and good water. The residue is well set in Pine, Oak, and Chestnut, and one mile from a bold creek. Any gentleman wishing to purchase, will communicate with the subscriber. EDWARD R. COKE, Feb. 1852.—2-21* Burnt Ordinary, James City Co., Va.

HIGHLAND NURSERIES, NEWBURGH, N. Y.

A. SAUL & CO. have the pleasure to announce to their patrons, and the public in general, that their stock of Fruit and Ornamental Trees, which they offer for sale the coming spring, is of the very best quality, and embraces everything in their line that can be procured in the trade.

Dealers and planters of trees on a large scale, will be treated with on as liberal terms as can be done by any establishment of reputation in the country. They flatter themselves that for correctness of nomenclature of fruits, (which is a serious consideration to planters) that their stock is as nearly perfect as it possibly can be, having been all propagated on their own grounds, from undoubted sources, under the personal supervision of Mr. Saul. They have propagated in large quantities all the leading standard varieties, which are proved to be best adapted for general cultivation, especially those recommended by the American Pomological Congress at its several sessions, as well as all novelties of recent introduction, and kinds particularly suited to certain localities, and sections of the Union and Canada.

Their stock of Pear Trees is the largest they have ever had to offer for sale, and among the largest in the country, and consists of over 50,000 saleable trees.

The stock of Apple Trees is also very large, as well as Plums, Cherries, Apricots, Peaches, Quinces and Nectarines. Also, Grape Vines, Gooseberries, Currants, Raspberries, Strawberries, &c., &c.

Pears on Quince, Cherry on Mahaleb, and Apple on Paradise stocks, for pyramids and dwarfs for garden culture, and of which there is a choice assortment of the kinds which succeed best on those stocks.

DECIDUOUS AND EVERGREEN ORNAMENTAL TREES AND SHRUBS.

Embracing all the known kinds suitable for street planting, of extra size; also, the more rare and select, as well as all the well known kinds suitable for Arboretums, Lawn and Dooryard planting, &c., including Weeping Trees, Vines, Garden and Climbing Roses in great variety. Hybrid Perpetuals, Hybrid China, Hybrid Bonbons, Hybrid Damasks, Hybrid Provence, and Bourbon, Tea, China and Noisette, and Prairie, and other Climbing Roses.

A large quantity of Arbor Vitæ for Screens, Buckthorn, Osage Orange, and other hedge plants.

The above will be sold on as liberal terms as similar stock can be purchased elsewhere. For further particulars see catalogues, a new edition of which is just issued, and will be forwarded to all post-paid applicants by mail. A liberal discount will be made to purchasers who buy to sell again, and extensive planters on their own account.

P. S.—Freight paid to New York.

Newburgh, March 1, 1852.

[3-21]

Fruit and Ornamental Trees.

ELLWANGER & BARRY beg to remind those who intend to plant next spring, that their stock of Standard Fruit Trees for orchards, Dwarf Fruit Trees for gardens, Ornamental Trees for streets, parks, gardens, and pleasure grounds, Shrubs, Roses, &c., is very large, and offers great inducements to those who desire first rate articles.

A complete Descriptive Catalogue is sent gratis to all who apply post-paid and send stamps for postage, which must now be pre-paid—5 cts. for 500 miles or under; 10 cts. over 500 miles and below 1000. A Wholesale Catalogue also furnished.

See advertisement of Shrubs, &c., &c.

Mount Hope Nurseries, Rochester, N. Y., March 1, 1852.

Fruit Trees.

I AGAIN offer a large stock of Trees—about 100,000—of fine thrifty growth, composed in part of Apple, Pear, Peach, Cherry, &c., together with an assortment of Green-House Plants suitable for bedding out—all of which are offered at extremely low prices.

Wholesale prices of Apple Trees will be from \$9 to \$10 per 100.

I would recommend to buyers, after examining other nurseries, to inspect mine before purchasing.

CHARLES POWIS,

Greece, Ridge Plank Road, N. Y., March 1, 1852.—3-21.

Osage Orange for Hedges.

WE can furnish a number of fine yearling plants at \$1.50 per 100, or \$10 per 1000, or at \$5 where 3000 or more are taken. Orders should be sent early. It takes about 32 plants to the rod, planted either in single rows at six inches apart, or in double rows a foot apart—either of which makes a good hedge. ELLWANGER & BARRY, Rochester, N. Y., Jan., 1852.

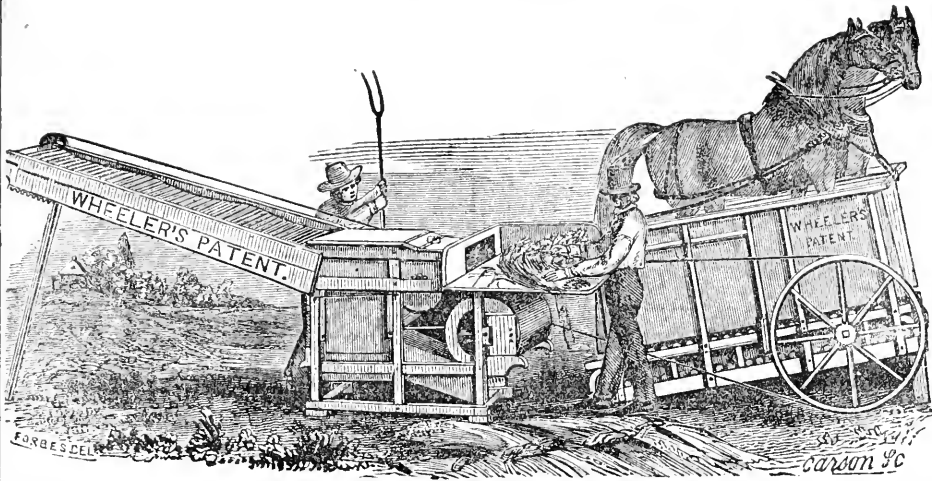

**New York State Agricultural Works,
ALBANY, N. Y.,
BY WHEELER, MELICK & CO.**

THE subscribers are this season enabled to offer to Farmers, a new and most valuable and useful Machine. The successful combination of a WINNOWER with our Overshot Thresher proves another of its great advantages. The Winnower is attached with much less Gearing than in the Undershot Machines, rendering it much more durable and compact, and more easily propelled. It has now been fairly tested, (a large number having been in constant use during the past Threshing season), and has already in some instances superseded the most approved of the other kinds of Winnowers, the owners of which have thrown them aside after a thorough trial of ours. We have numerous commendatory letters from gentlemen who have purchased and used our Winnower, and we give extracts from a few of them.

Extract from a Letter of WM. OSBOEN, Esq., of Waterville, N. Y.

Messrs. WHEELER, MELICK & Co.—Gentlemen:—My Uncle wishes me to say to you that his Winnower more than answered his expectations. My own opinion may be gathered from the fact that I want one as soon as you can forward it. It is unquestionably the most perfect thing ever got up for Threshing and Cleaning. I have considerable acquaintance with labor-saving Agricultural Machines, and I never yet saw anything which for its simplicity and perfect adaptation to the wants of Farmers, compared with your Machine.

From E. FRENCH, Esq., Bridgeport, N. Y.
Messrs. WHEELER, MELICK & Co.—Gentlemen:—If you could see the admiration your Winnower receives from all, you could not help feeling proud of it. You may expect several orders from here next season. My neighbors are scrambling for their turn to have me do their threshing, but will not employ other machines although they go about begging for work.

From J. GLENDENNING, Esq., Newport, R. I.
Messrs. WHEELER, MELICK & Co.—Gentlemen:—I am pleased to say that the Thresher and Winnower exceed my most sanguine expectations. I can get through 350 to 400 bushels of Oats per day.

From H. J. CREWELL, Esq., Columbia, N. Y.
Messrs. WHEELER, MELICK & Co.—Gentlemen:—The Thresher and Winnower you sent proves to be beyond my expectations. I have the pleasure of writing to you for one more, if you can furnish it within the next 3 or 4 weeks. We might add many more equally flattering testimonials.

Price of Double Power with Thresher and Winnower, \$225

The superiority of WHEELER'S PATENT RAILWAY CHAIN HORSE POWER, and OVERSHOT THRESHER and SEPARATOR is universally acknowledged wherever they have been tested. Thousands of them are in use, many of which have threshed from 50,000 to 100,000 bushels

of grain, and are still in good condition. They are beyond doubt the most durable and economical machine in use.— Their capacity has been tested by repeated trials as well at the New York and Pennsylvania Fairs, as on several private occasions, in competition with another Machine made in this city which has been advertised to be far superior to ours, and in every instance the result has been about one-third, and in some instances more, in favor of our Machines. In every case except one where we have submitted our Machine to a working test at Fairs, it has taken the highest premiums, and in that excepted case the Committee decided that our machine performed its work in 8 minutes and its competitor in 11¾ minutes, being nearly one-third in favor of ours.

We have also exhibited ours in competition with the same machine at the State Fairs in Ohio, Michigan and Pennsylvania and also at the Provincial Fair of Upper Canada, at all of which we received the highest premiums, viz: In Ohio, a Silver Medal and Diploma; in Michigan, \$20; in Pennsylvania, \$10; and in Canada, a Diploma.

We have numerous similar testimonials from County Societies, where we have always received the highest premiums awarded to Chain Powers.

Price of One Horse Power, Thresher, Separator and Belting, \$120
Two Horse Do., 145

Besides the above, we manufacture and keep constantly on hand among other articles, Clover Hullers, Straw and Stalk Cutters, Portable Saw Mills, (adapted to Horse Powers,) and Single Powers with Chain Gear attached. These last are extensively used in large Dairies, and are so arranged that the Power is used at pleasure for either threshing, churning, wood sawing, or other purposes.

All machines made and sold by us are warranted to give satisfaction or they may be returned, after a reasonable time for trial.

Orders are solicited and will be promptly filled.
WHEELER, MELICK & CO.
Corners of Hamilton, Liberty and Pruyn Streets,
(Near the Steamboat Landing,) Albany, N. Y.
April, 1852.

The Subscribers have obtained from Messrs. Wheeler, Melick & Co., of Albany, the exclusive sale and general agency in Rochester and Western New York, of their celebrated Agricultural Machines, which we will sell at their Albany prices, adding transportation.

Albany The Works,

No. 60 Lancaster St., West of Medical College.

THE subscriber has now on hand, and is prepared to furnish to Agriculturists, Horse-Shoe and Sole Tile, for land drainage, of the most approved patterns. They are over 1 foot in length, 2¼ to 4¾ inches calibre, from \$12 to \$18 per 1000 pieces—being the cheapest and most durable article used. Orders from a distance will receive prompt attention.

[4-6]

JOHN GOTT, Jr.

EMERY & COMPANY,
 Sole Manufacturers for the United States,
 OF THE
New York State Agricultural Society's
 FIRST PREMIUM
RAILROAD HORSE POWER,
 Patented by H. L. EMERY, February 24, 1852.
 Manufactory on Hamilton, Liberty and Union Streets;
 Warehouse and Sale Room, 363 and 371 Broadway,
 ALBANY, N. Y.

THE above Horse Powers have been awarded the highest Premiums at the Fairs of the New York State Agricultural Society in 1850, and again in 1851; also, the highest Premium at the Michigan State Fair, at Detroit, in September, 1851, where a majority of the Committee owned and were using Wheeler's Powers on their farms, having purchased them previous to seeing our own; also a Gold Medal at the American Institute in 1851. It was also exhibited at the State Fairs of Ohio, Maryland, and Pennsylvania, and received the highest awards which could be given by the rules of their Societies. In every case, it has been in competition with all endless chain Powers of any note in this country.

Over SIX HUNDRED sets of the above Powers were sold and put in use from June to January last, not one being returned or failed.

To enable the public to distinguish the above Horse Power from all others, we here show its principle, and most important parts, by diagrams and references—beside like diagrams and references of the Rack and Pinion Power, as made by ourselves, Wheeler's and others; and also the Rack and Pinion with epicycloidal teeth, which has long been successfully used in this vicinity, and which, with our recent improvements in its adaptation and application to our Horse Power machinery places it the first on the list of Rack and Pinion Powers.

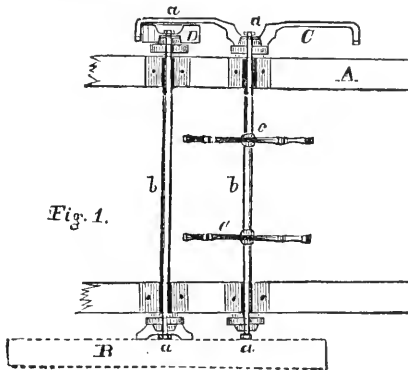

Fig. 1.



Fig. 2.

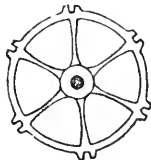

Fig. 4.

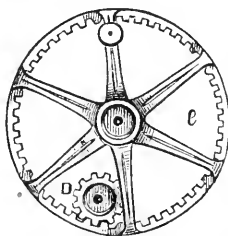

Fig. 3.

Top view of the Running Gear, and a portion of the frame work of H. L. EMERY'S Patent Changeable Railroad Horse Power.

Fig. 1. A A—Main sills or timbers of the Power supporting the shafts.
 B—Band pulley upon one of the shafts.
 D—Pinion, or small gear, upon the same shaft with pulley.
 C—Converge or internal gear upon the main shaft, and working into and over the pinion.
 b b—Main and counter shafts of power.
 c c—Reels upon the main shaft, which support the endless flooring in its circuit, and carry the shaft.
 a a a—Couplings upon the ends of the shafts, fitting all the pulleys and gears.

Fig. 2. Shows a side and edge view (enlarged) of the couplings.

Fig. 3. Side view of converge or internal gear and pinion.

Fig. 4. Side view of one of the two reels, c c, on the main shaft.

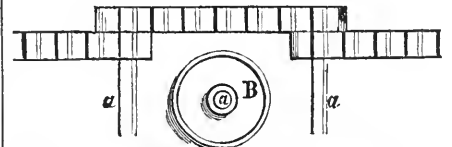
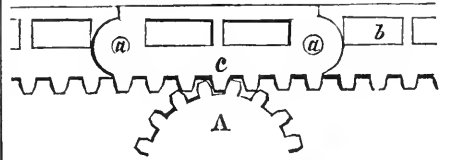

Common Rack and Pinion Power, as manufactured by ourselves, Wheeler's and others.

B—Side view of one of the 72, (or 36 on each side,) small truck or friction wheels, which traverse with the endless flooring—being about 3 3/4 inches diameter.

C—Side view of one of the 72 (or 36 on each side,) links or segments of the chain, each of which are six inches long, as seen connected with others. a a a—The eyes of the links and small rods crossing the power and extending through the links, and far enough outside to receive the small trucks.

A—Side view of a section of one of the pinions or small cog wheels, two of which are placed upon the main shaft, and receive the motion and force from the eyes on the links of the chain. This pinion is about 4 1/2 inches in diameter, and the band pulley is used upon the same shaft, which for thrashing, is four feet diameter. The lower view represents the teeth or cogs, as seen with links inverted.

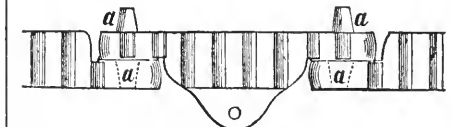
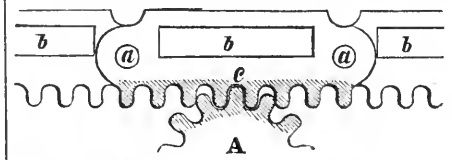

Emery's Improved Patent Rack and Pinion Power, with Epicycloidal teeth.

c—Shows a side view of one of the links or sections of the chain, of which there are but sixty, or thirty on a side, and are each seven inches long; every alternate link is cast with dowels, a a a a, projecting each side; those on the inside receive the truck wheels, while those on the outside connect with other links, thus avoiding the necessity of the truck wheels, and expense of fitting up. The eyes of the links and truck wheels are cast upon steel chills—making a perfect, and hard smooth surface, which will not wear or break—while

the dowels are sufficiently large and strong to withstand more than the cogs themselves.

The lower edge of each link is widened equal to the face of the pinion, and the cogs made to extend the whole width of the pinion, as shown in the lower cut, representing the link inverted, presenting double the strength and driving surface, as shown in the last link; every alternate link is confined to the plank flooring by a small screw bolt passing through a flange upon the inside of the link, and under the plank itself.

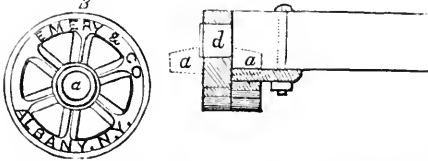

A—Shows a section of the pinion, which is a little larger in diameter than the last—the teeth of which are epicycloidal in form—as are those on the links working into them—which is acknowledged by all mechanics and engineers to be the strongest and most perfect form of teeth, and works with less friction and wear, as the driving surfaces present to each other a rolling, instead of sliding friction; this kind of teeth, on account of their rounded form, work much deeper into each other, and have little or no inclination to lift out of gear.

The last cut shows the construction of the truck wheels, which are $1\frac{1}{2}$ inches larger in diameter, and revolve on larger circles at the ends of the power—giving them an advantage over the smaller wheels. A section of a link is shown with the end of the flooring attached; these planks are all one inch wider, and consequently wear up by use much closer, before bending or breaking under the weight of the animals. As a Rack and Pinion Power, the latter has every advantage over the common kinds in use; is manufactured at a less cost; is equally strong and durable, and is more easily handled, as its weight is some two hundred pounds less.

Either of the above kinds of Powers are offered to the public, each upon its own merits, with a full warranty as to workmanship, materials and operation, (and with a guarantee of right of using in all parts of the United States,) subject to be returned within three months—and purchase money refunded. For prices, &c., see Illustrated Catalogue, furnished gratis on application, or by mail.

The first on the list is the highest in cost, and is found preferable in all cases, and under all circumstances. The power of the revolving platform being applied to the main shaft, by means of reels with larger diameters than the pinions used in the Rack and Pinion powers, the stress upon the several parts is in no way as great—and the liability of wear or breakage, from use or accident, is removed. The whole of the gearing consists of less than one-seventh the number of cogs in the Rack and Pinion Power; and these are wholly removed from under the horses to the outside of the power—free from dirt, dust, &c., and always easily kept in order or cleaned, which is an advantage over all Rack and Pinion Powers. This Power has also the advantage of the changing of force and velocity to accommodate it to any variety of work, without any additional cost or danger to the gearing or other parts. When the main shaft runs but fifty-six revolutions per minute, the diameters of the gears are such as to increase or decrease the velocity to two hundred and twenty-four, or as slow as fourteen revolutions per minute, when the animals (either horses or oxen) walk but two miles per hour—being about two-thirds the travel which is necessary with the Rack and Pinion Powers, to produce the same effect. This last fact is one of its principal features, and one of the greatest importance to the farmer. The gearing, as well as pulleys and couplings, all agree, and can instantly be transposed—each to each, and side to side. In this power the centers of motion of the gears are always in the same position to each other—requiring no guard or binding track over the chain above the pinions, to keep the gears together, as is absolutely necessary with all rack powers, and which serve to check the force of the power; and as the driving faces of the teeth on the rack and pinions become worn off, the loss of force increases, until they eventually stop, break, or slip by each other. The length of the sections or links of the chain, as also the width of the planks of the flooring, are same as in the improved Rack Power

last described. With the above advantages, together with the epicycloidal form of teeth, adopted this season in its construction, the superiority of this power is readily seen.

This Power is admirably adapted for driving Threshing Machines, Circular Saws, Cotton Gins, as also Machine Shops, Elevators, Ferry-boats, Discharging and Loading vessels, Pile-driving, Cross-cut sawing, Pumping, Grinding gram, Churning butter, Cutting hay and stalks, Shelling corn, Grinding apples, &c. The angle of elevation necessary to operate this power, is never greater, but often less than either of the others here described, and which is inside of $1\frac{1}{2}$ inches to the foot, with horses weighing 1000 pounds each, and without any harness. It has also an admirable arrangement for adjusting and tightening the chain, *not possessed by either of the others*—together with an improved brake for stopping the whole instantly—all within the power, and independent of the band and pulleys, and does not require to be changed, when gears and pulleys may be. The pulley used for threshing, with this power, is but three feet diameter, to effect the same as a four foot wheel does with the Rack and Pinion Power.

In all cases the shafting of all machinery manufactured by us is made to run in Babbitted Boxes, they being the most durable and perfect box in use—and not generally used by other manufacturers.

April, 1852.

New York Agricultural Warehouse

A. B. ALLEN & CO.,

189 & 191 Water Street, New York.

PLOWS of a great variety of patterns and different sizes calculated for sward and stubble land, wet meadows and recently drained swamps, where roots abound. Among these plows, also, are the deep-breaking-up, flat-furrow, lap-furrow, self-sharpening, side-hill, double mould-board, corn, cotton, cane, rice, and subsoil, with single or double wings.

HARROWS—Triangular, Square, Geddes, and Scotch.

ROLLERS with iron sections one foot long, and of different diameters. These can be arranged on an iron shaft of any width.

CULTIVATORS of upwards of twenty different kinds, steel tooth and cast iron.

SEED SOWERS of six different kinds and prices.

HORSE POWERS—Endless chain and circular, of wood or cast iron.

THRESHERS, with or without Separators.

GRAIN MILLS of cast iron, and burr stone, to work either by hand, horse, or water power.

CORN SHELLERS, single and double, large and small, cylindrical to work by hand, or otherwise.

STRAW CUTTERS with spiral, straight, or circular knives.

VEGETABLE CUTTERS, for turnips and other roots, together with a great variety of all other Agricultural and Horticultural Implements kept in the United States, such as hoes, shovels, spades, rakes, manure and hay forks, grain cradles, scythes, snaths, &c., &c.

CASTINGS of all kinds, for plows, cotton gins, and rollers.

WAGONS and CARRS, for horse, ox, or hand.

STEAM ENGINES, for farm and other purposes.

Our Implements occupy three large stores, and we believe they make up the largest and most complete assortment in America. In addition, we have a machine shop employing upwards of one hundred men, where any articles in our line can be made to order.

A. B. ALLEN & CO.,

Feb., 1851.

189 and 191 Water St., New York.

A Productive Farm for Sale.

THE subscriber unable to give his active attention to the Farm he has cultivated for many years, offers the same for sale—either the whole or a part. 285 acres are cultivated, either cropped with grain, in meadow, pasture, or in preparation for spring crops. 65 acres are in thrifty woods.

This farm obtained the State premium, and a full description may be seen in the State Society's Transactions for the year 1847. Being in a system of rotation, cropped and seeded, a purchaser will find all the necessary work prepared for the season, admitting of possession whenever desirable. The dwelling and buildings are comfortable, sufficient, and in good order.

A reasonable portion of the purchase money may remain on good security.

For other information and terms apply to Messrs. H. T. & Wm. Delafield, Front st., New York; B. P. Johnson, Esq., Agricultural Rooms, Albany, or to the subscriber on the premises, at Oakland, near Geneva.

April, 1852.

J. DELAFIELD.

Prices of Agricultural Products at the Principal Markets in the United States. — Mar. 18, 1852.

	New York.	Boston.	Rochester.	Chicago.	Cincinnati.	Philadelphia.
Beef, per 100 lbs.	\$5.25 a 6.50	\$6.00 a 7.50	\$4.50 a 5.00	\$4.00 a 4.25		\$4.25 a 5.75
do mess, per bbl.	9.50 12.50	10.00 12.00	11.00 11.50			14.50 15.00
Pork, per 100 lbs.			6.00 6.25	4.90 4.12½		
do mess, per bbl.	16.25 16.75	16.00 18.00	15.00 15.50	16.00 a 16.50	\$14.50	16.50 17.00
Lard, per lb.	9 9½	9½ 10	8 10	7½ 8	6½ a 8½	9½ 10½
Butter, do	18 28	20 25	16 18	8 10	9 16	14 16
Cheese, do	6½ 7½	6 8	6 7	5 7	6½ 7½	
Flour, per bbl.	4.63 6.00	4.75 5.75	4.50 5.00	3.00 4.00	3.22 3.40	4.25 5.75
Wheat, per bush.	1.10 1.15	1.00 1.25	98 98	1.00 50	68 63	92 1.02
Corn, shelled, per bu.	63 64	64 63	48 50	28 35½	25 28	61 61
Rye, do	74 75	72 73	69 70	30 30	50 55	72 72
Oats, do	41 49	40 43	32 32	17 20	20 21	33 33
Barley, do	76 80	75 75	67 70		30 40	
Clover seed, do	9½ pr. lb.	9 a 11 per lb.	4.50 5.00	12½ per lb.	6.00	5.00 5.50
Timothy seed, do	14.15 per tee.		2.00 2.50	2.25 2.5	1.50 2.25	2.75 3.25
Flax seed, do	13.60 per tee.	1.20 1.35	1.25 1.50	1.00 1.00	1.00 1.00	1.30 1.35
Hay, per ton	14.00 16.00	13.00 15.00	8.00 12.00		8.00 11.50	
Wool, per lb.	30 44	31 46	30 40	30 40	26 35	52½
Wood, hard, per cord			4.00 4.50	3.25 5.00		

CONTENTS OF THIS NUMBER.

Cows and Carrots,	105
Beef-Root Sugar,	107
Under Draining,	109
Milch Cows, and Calves,	110
Willows,	111
Large Crop of Ruta Baga,	112
Agricultural Productions, as shown by the Census of 1850,	116
Culture of the Grape, and Wine Making,	117
Experiment with Potatoes,	118
Horses for the Farm,	119
CONDENSED CORRESPONDENCE.—Butter-Making Experiments; Thick and Thin Sowing; To Clean Spring Wheat from Chess, Oats, &c; Planting Small Potatoes; Home-Made Guano,	113
Merino, South-Down, and Leicester Sheep; Soaking Corn in a Solution of Hartshorn; Experiment with Poultry; Guano on Corn,	114
Bees; Culture of Tobacco,	115
EDITOR'S TABLE—Inquiries and Answers; Notices; &c,	127
HORTICULTURAL DEPARTMENT.	
Fruit Rooms,	122
Hints for the Season,	125
The Candytuft,	126
Answers to Correspondents,	128

ILLUSTRATIONS.

Outline of the Wild Tartarian Horse,	119
“ “ Modern Hunter,	120
“ “ Head of the Arabian Horse,	120
“ “ Head of the Hungarian Horse,	120
A Suffolk Stallion,	121
Plan of a Fruit Room,	123
Interior View of a Fruit Room,	123
Longitudinal Section of a Fruit Room,	124
Candytuft,	126

Improved Stock.

CATTLE of the Durham, Devon, Hereford, Alderney, and Ayrshire breeds.

SHEEP of the Native and French Merino, Saxony, South Down, and Cotswold.

PIGS of the Lincoln, Suffolk, and Berkshire breeds.

From our long experience as breeders and dealers in the above kinds of stock, and our excellent situation for purchasing and shipping, we think we can do as good justice to orders, as any other house in the United States.

A. B. ALLEN & CO.,

April 1, 1852—tf. 189 and 191 Water st., New York.

Field and Garden Seeds.

WE have recently imported from England, France and Germany, and have grown in the United States, expressly for us, a fine assortment of the best and most approved kinds of Field and Garden Seeds.

Agricultural and Horticultural Implements, a large assortment of the various kinds suitable for North and South America.

A. B. ALLEN & CO.

April, 1852—tf. 189 and 191 Water st., New York.

The Journal of Agriculture,

A SEMI-MONTHLY Periodical of 32 pages. Edited by WILLIAM S. KING, Prof. J. J. MAPES, and A. W. DODGE, Corresponding Secretary of the Massachusetts Board of Agriculture. Published at Nos. 8 and 10 Gerrish Block, Blackstone Street, Boston. TERMS—\$2 per annum; Four copies, \$6; Ten copies, \$14. The money must always accompany the order.

Among the principal contributors are M. P. Wilder, President Massachusetts Board of Agriculture, Dr. Charles T. Jackson, Levi Bartlett, John W. Proctor, President Essex Agricultural Society, Samuel Walker, President Massachusetts Horticultural Society, J. E. Teschemaker, S. H. Huntington, Hartford, T. B. Miner, Author of American Bee Keeper's Manual, Rev. J. L. Blake, D.D., Author of Farmer's Every-day Book, &c. Rev. W. Clift, and many other well known writers and practical men.

Good Agents wanted in all parts of the country.

Address WILLIAM S. KING,

8 and 10 Gerrish Block, Blackstone st., Boston, Mass.

April, 1852—2t.

Clover and Timothy Seed.

NOW on hand and for sale at the Genesee Seed Store and Agricultural Warehouse, 63 and 65 Buffalo St.

500 bushels good Timothy Seed.

200 “ prime Clover.

Rochester, April, 1852. J. RAPALJE & CO.

The Practical and Scientific Farmer's own Paper.

THE GENESEE FARMER,

A MONTHLY JOURNAL OF

AGRICULTURE AND HORTICULTURE,

ILLUSTRATED WITH NUMEROUS ENGRAVINGS OF

Farm Buildings, Domestic Animals, Implements, &c.

VOLUME XIII, FOR 1852.

DANIEL LEE & JAMES VICK, JR., EDITORS.

P. BARRY, Conductor of Horticultural Department.

Fifty Cents a Year, in Advance.

Five Copies for \$2—Eight Copies for \$3, and any larger number at the same rate.

All subscriptions to commence with the year, and the entire volume supplied to all subscribers.

Subscription money, if properly enclosed, may be sent (post-paid or free) at the risk of the Publisher. Address to

DANIEL LEE,

Rochester, N. Y.

December, 1851.

POSTAGE ON THE GENESEE FARMER.—50 miles or under, five cents per year; exceeding 50 miles and not over 300, ten cents; exceeding 300 and not over 1000, fifteen cents; exceeding 1000 and not over 2000, twenty cents; exceeding 2000 and not over 4000, twenty-five cents; for any distance exceeding 4000, thirty cents.

STEREOTYPED BY J. W. BROWN, ROCHESTER, N. Y.

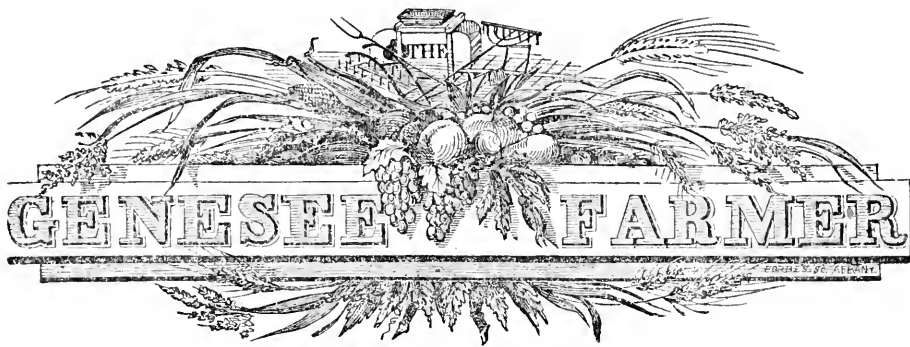

IRRIGATING AND MANURING LAND BY STEAM-POWER.

RESULTS of much importance in farm economy have been realized in England by the use of steam-power to irrigate and manure both cultivated and meadow lands. Whole farms of several hundred acres have been increased four-fold in value and productivity, with a small outlay of capital, by a little skillful agricultural engineering. It is stated, on what is regarded as reliable authority, that 112 pounds of coal will raise 715 tons of water ten feet high, which will suffice to cover seven acres of ground an inch in depth. This is equal to a steady rain of ten or twelve hours duration; and it encourages the hope that steam may soon give the farmer entire control over the most important elements of all crops. Nearly half of the solids in all plants is composed of the elements of water; and it is the medium for conveying both mineral and organic food from the soil into the cells and vessels of vegetables which have their roots in the earth. Hence, to secure a perfect command of water—removing it promptly and cheaply when in excess, and supplying it readily and economically when deficient in quantity—is a desideratum of inestimable value, if attainable. Without resorting to rivers or creeks, enough falls upon every farm and field in the course of twelve months, for all useful purposes, if the surplus at one season be stored up to meet the deficiency at another.

On one farm which has four hundred acres under artificial irrigation, the water is pumped up seventy feet before it reaches the steading or barn-yard, where all the manure is liquified by running water through it when the process of decay is going on. Water thus charged with the elements of fertility, not in excess for immediate absorption by the roots of plants, is forced by steam-power through iron pipes laid under ground that lead to every field; and from these "mains" lateral and smaller pipes are extended, upon which penstocks are raised for the attachment of long hose, not unlike those used by fire companies, from the pipes at the ends of which a perfect shower is made to rain upon the thirsty land. The nozzle of the pipe from which the jet of water issues is made quite flat, and a six-horse power engine enables a man and a boy to irrigate abundantly ten acres in as many hours. The cost of the iron pipes and hose on Mr. KENNEDY'S farm, (the one referred to,) was £2 10s., or \$12.50 an acre. For this trifling outlay in comparison with the objects attained, (the steam engine being used for other purposes,) the farm now keeps four times the stock it was capable of feeding before this system of manuring plants as they needed food, and supplying them at all times with water when thirsty, was adopted.

The reader will see that all the labor of hauling out and spreading manure is saved; while no crop ever receives more than it is able to take up and elaborate without waste. Careful experiments have shown that 100 lbs. of guano applied in this economical manner, give as good a result as 200 lbs. used in the solid form, and in the usual way. We

have long believed that not far from half of the fertilizing elements contained in common manure, failed to enter the roots of cultivated plants, and was really lost to the farmer and to the world.

In cold weather, the escape steam can aid the fermentation and solution of manure, should this operation be more tardy than is desirable; but as the mass of manure is in a water-tight reservoir, from which the liquid is drawn off whenever it is desirable to remove it, the decay of the organic substances may be hastened or retarded at the will of the operator.

Treated in this admirable manner, meadows have been mown every month for soiling dairy cows, fattening cattle, and other stock, and have yielded the astonishing amount of *eighty tons* of Italian rye grass in a season, worth from 12s. to 13s. a ton. Some irrigated meadows paid £31 rent in 1850 and 1851; and hundreds of acres were let at £20, or \$100 dollars per acre.

In some cases earthen pipes, something like hard burnt draining tile, but larger, thicker, and much stronger, are used for the distribution of water and manure. These cost less than half as much as iron pipes. Hose 800 yards in length has been used, so that a single penstock answered for irrigating ten acres or more. At two or three establishments the water is pumped into an elevated tank that gives a head of seventy or eighty feet upon the pipes and hose, which of course forces more water through any given aperture, and favors the spreading of the artificial shower of rain; but the force of a small engine without the head, is found to be all-sufficient to drive the liquid wherever it is needed, as the doctors say, *pleno rivo*.

What water has accomplished in canals, and steam on railroads for transportation and travel, water and steam are about to do for the farmer on his own estate. Everybody knows that the use of steam as a motive power, is an invention of but yesterday in the history of our race. If the agricultural engineers of the largest experience, and of unquestioned science, in England, are right in their calculations to the effect that 112 lbs. of coal will elevate 715 tons of water ten feet; then it may be demonstrated that an American farmer can abundantly irrigate an acre of land *five times* in a season, by burning one-half of the cornstalks that will grow in a single crop on said acre the year previous. It is the burning of organized carbon and hydrogen in coal, wood, and other fuel, that generates heat and steam; and on good land, we know of no plant or forest tree that will organize carbon and hydrogen faster than our indigenous, unequalled maize. This organized carbon and hydrogen will be sufficient to form all needful power in the systems of working horses, oxen, and mules, and in the more durable and powerful system of a steam agricultural locomotive.

By the kindness of Dr. SPANSBURG, of the Patent Office, we are in possession of a very late official report made by the London Board of Health, in which the subject of irrigation and conveying city sewerage ten miles into the country, driven through pipes by steam, is discussed and illustrated in the fullest manner. The most valuable of these illustrations we shall have engraved, and furnish our readers with all the material facts of this new application of science to agriculture. In Germany, some sixty-two square miles of soil have been made by simply driving muddy water, like that of the Missouri river, only more so, through earthen pipes, extended over a sand-desert. To illustrate the *modus operandi*, let us suppose that one has 100 acres of very poor and almost drifting sand, with a clay bank and a stream of water on one side of the tract. By plowing up this clay, and washing it with running water, a very muddy stream may be formed; and with a sufficient head, and pipes of from three to six inches aperture, 1000 tons of clay may be spread every twenty-four hours over these 100 acres of sand, by the labor of twelve horses. That water having a full head of only twenty feet will run rapidly through a six inch, or even a three inch bore, every school boy knows.

SUMMER FALLOWS.

Most agricultural writers agree in condemning the use of the naked or summer fallow; and though many first rate practical farmers in this country and in Europe still practice and recommend it as the best means of cleaning the soil and preparing it for wheat, yet in the best farming districts of England it is altogether dispensed with, especially on the light sandy soils, the turnip crop being substituted in its place with advantage to the soil and profit to the farmer.

Turnips are sown in ridges, and kept clean by the free use of the horse-hoe; and the land is always plowed three times previous to sowing. Hence they are rightly called a *fallow* crop, and leave the land in a very clean and rich state for the subsequent grain crop.

Indian corn is our *fallow* crop; for, though it differs in very important respects as regards exhaustion of the soil, yet it is similar to the turnip in affording the opportunity of cleaning the land, admitting the employment of the horse-hoe throughout the summer months, and succeeding best on light loamy soils, or those which are generally apt to produce most weeds. Yet many good farmers, prevented by the shortness of the working season from cleaning the land as they would wish before planting, find it difficult, and in many instances impossible, to keep their soil free from weeds without the use of a summer fallow occasionally.

Though the principal object in summer fallowing is to destroy the weeds, yet other results are obtained equally desirable and beneficial. The constituents of plants generally exist in the soil in a very *insoluble* condition; and as plants will not take their food except in solution, it is a matter of great importance to the farmer not only to have the necessary elements in his soil, but to have them in that condition which is necessary for their assimilation by the plants grown. There is no better way of effecting this result than bringing as much of the soil as possible into direct contact with atmospheric air, the oxygen uniting with the organized carbon of the soil and forming carbonic acid, which exerts a powerful effect, in conjunction with water, on the insoluble mineral substances in the soil, disintegrating their important elements and so altering their chemical combination as to supply the plants with food suited to their wants. There are also noxious substances existing in many soils, especially those undrained, which oxygen renders harmless. Besides the benefit of oxygen on the *mineral* ingredients, it exerts a no less beneficial action on the *organic* matter found in all fertile soils. Thus there is great reason to believe that plants can not take the nitrogen which they contain in the form of nitrogen, but that it must be converted into ammonia or nitric acid. Now, under the influence of oxygen this conversion takes place, and it can not in any way be effected without it.

In view of these facts, the object of the farmer will be to render his soil as permeable to air as possible. Thorough under-draining is one of the grand means of doing this; and though it costs \$20 to \$30 per acre, yet on many farms it is a very profitable investment. Frequently plowing and stirring the land, exposing different surfaces to the atmosphere, and thoroughly pulverizing the soil, are the common means used to obtain the desired result. On stiff, heavy soils, those which exclude the atmosphere and are generally full of undecomposed organic matter and valuable though insoluble minerals, *summer fallows* are attended with surprising results, and this for the reasons assigned above; and such is the richness of many of these kinds of soils, so great is the amount of fertilizers locked up in them, that large crops may be obtained for many years without any apparent exhaustion, by simply summer fallowing them.

But on light sandy soils, which admit the atmosphere, there is no such accumulated undecomposed matter; and the only value of the summer fallow is to clean the land. To obtain good crops on such soils, it is absolutely necessary to apply some kind of

manure; and to obtain this in sufficient quantities, is the great difficulty in adopting a course of rotation that will yield profitable returns and improve the soil. We cannot recommend farmers to purchase guano to apply to wheat; for though it greatly increases the crop, yet from its high price and the low price of wheat, it is not a profitable investment. It might pay to apply it to mangel wurzel, ruta бага, carrots, &c.; which being consumed on the farm by stock, would furnish much valuable manure.

Growing large crops of clover is another great means of obtaining manure, and substitutes the summer fallow. If the land is clean, there is no doubt that a much larger crop of wheat can be obtained by letting the clover grow till in full bloom, plowing it under, and cultivating once or twice before sowing, than if it had been plowed early in the spring, and summer fallowed in the best possible manner. And even if the first crop of clover is cut early for hay or green fodder, and the second growth plowed in immediately before sowing, a better crop of wheat is obtained than by summer fallowing. But where, instead of a summer fallow, land is sown to barley or oats, even though it is perfectly clean, the following wheat crop, except well manured, can not be expected to be so good as after clover or summer fallow, for the reason that barley, oats, corn, and timothy, exhaust the soil of the elements the wheat crop specially requires; whereas clover supplies them both in root and stem. Yet we have known a better crop of wheat obtained after a crop of barley, than after a pseudo summer fallow; or where land was plowed about midsummer and allowed to lie in that state a couple of months, when it would be plowed again and sown; whereas the land for barley would be plowed early, and be well dragged and rolled, and would turn up in the fall in a much better condition than if it had been summer fallowed in the above style.

If land gets very weedy, and must be summer fallowed, let it be done well and effectually. Plow it in the fall, and let it lie exposed to the mellowing influence of frost; for such is the necessity for hurry in getting in spring crops, that it can rarely be plowed early enough in the spring to make a good summer fallow. On heavy soils, which are generally fallowed for wheat, a clod-crusher something similar to *Croskill's Patent Clod-Crusher* as given in the September number of the *Farmer*, would be an implement of great use; and we are surprised some of our enterprising agricultural implement makers have not yet supplied us with one. We know of no other implement that will so readily and economically pulverize stiff soils.

PEAS.

LAST season was unusually well adapted for the growth of peas; and wherever sown in this neighborhood, if well put in, good crops were obtained. All farmers who have been in the habit of growing peas, agree in recommending them as a crop that but slightly impoverishes the soil, and at the same time, if a good large crop is obtained, of being highly remunerative, and the land is left cleaner and in a better state for the following wheat crop than though it had been summer fallowed. We have seen several instances in which part of a field was sown to peas and the other part summer fallowed *well*, in which the wheat was a much better crop after the peas than after the summer fallow. But a large crop, one that will smother the weeds, is necessary to obtain this result.

In England they sow the large *Gray Pea*, very similar to the *Scotch Gray Pea* found in the seed stores, that is too strong for culinary purposes, but highly nutritious, and much used for feeding hogs, horses, and sheep. It is grown very extensively, and on wheat farms displaces the summer fallow. They are always sown in drills about a foot apart, and hand-hoed once or twice, to clean the land. Thirty bushels to the acre is about the average yield. Peas are usually sown broadcast here; but we think if they

were drilled with our grain drills, about twelve inches apart, and hoed, they would well pay for the labor by the extra yield, besides leaving the land in so much better condition.

The value of peas, compared with other commonly cultivated grains, will be seen from the following table :

Description of grain.	Water.	Dry substance.	Nitrogen.	Gross Mineral matter.	Phosphoric acid.	Alkalies, (potash and soda.)
Linseed.....	12	88	3.75	4.25	1.69	1.10
Peas.....	16	84	4.09	2.50	0.80	1.10
Wheat.....	16	84	1.80	1.60	0.75	0.50
Oats.....	16	84	2.00	3.00	0.50	0.50
Barley.....	16	84	1.60	2.50	0.75	0.65
Indian Corn.....	8	92	1.00	1.34	0.70	0.25

The amount of nitrogen, other things being equal, represents the relative nutritive value of different foods ; so that we see 100 lbs. of peas worth four times as much as Indian corn. But we cannot bring ourselves to such a conclusion without direct experiments ; and these have not yet been made. But, one thing is proved ; that the amount of nitrogen in the food, without reference to any other circumstance, represents the true value of the manure made by the animals consuming it. Thus, then, the manure made by hogs feeding on peas would be worth four times as much as though they were fed on corn, and two and a half times as much as though fed on barley. And when we remember that this large amount of nitrogen is obtained from the atmosphere, and that in the production of the starch in corn, wheat, barley, &c., considerable nitrogen is consumed, and that our soils are very deficient of nitrogen, no argument will be needed to show that peas are as profitable a crop as the farmer can raise. They do best on a clover sod that is clean and full of roots. They should be sown early, but will do if sown the first or second week in May. Two and a half to three bushels per acre is usually sown. If soaked for six hours previous to sowing, they are soon up and get the start of the weeds.

It may be considered a slovenly practice of harvesting, but is nevertheless adopted by a first rate farmer of our acquaintance, who grows several acres of peas every year. He takes a common roll wooden hay rake, takes out the two outside teeth, and with a good stout horse, pulls them up by the roots, and leaves them in wads of a convenient size for turning, pitching, &c. In this way he can do fifteen acres a day. If there are any left on the land unpulled after he has harvested the others, he turns in the hogs, who soon clean up every pea. He considers them the best food in the world for hogs. The pork, too, is of a very superior quality, and does not lose so much when made into bacon.

Pea straw, if well harvested, is very excellent food for cattle and sheep, and is very valuable for manure.

In Canada, oats are often sown with peas ; and ripening at the same time, they are cut, threshed, and ground together, making an excellent food for hogs and horses. The oats furnish a good support for the pea. But where wheat is to follow, we would not recommend this course.

The ravages of the *pea-bug* is a sad drawback on the culture of the pea. Early in summer, when the peas are in flower and forming pods, the female beetle deposits an egg in almost every pea. When matured, the pea does not appear injured ; but on close examination, we can discover in each a minute black speck, which is the *larva*. Dr. HARRIS says : "The eggs are laid only during the night, or in cloudy weather. Each egg is placed opposite the pea, and the holes through which they pass are so fine as scarcely to be seen, and are soon closed." The larva remains in the pea all winter, gradually consuming its internal substance, and in spring it is transformed into a perfect insect, pierces the skin, and emerges to deposit its eggs in the new pods. The larva has

a soft, whitish body; and a head small, scaly, and armed with strong and sharp cutting mandibles. The maggot, when it reaches maturity, gnaws a circular hole to the husk or skin of the pea, and even cuts round the inner surface which covers the aperture; so that, when changed to a beetle, by a slight dilation of its body it forces off the lid, and emerges the new-born *Bruchus*, as represented in the figure. In many of the peas the insect will be found dead. Whether this arises from a lower temperature than they are accustomed to, not invigorating them sufficiently to leave their habitations, or whether they return to feed when they can not make their escape readily, which is the case when the peas are confined in sacks, or heaped up in a warehouse, has not been determined.



The vitality of the seed is not usually destroyed, as the egg is deposited in the side of the pea, where the insect when hatched emerges, leaving the germ uninjured. It is doubtful, however, whether the plants raised from such peas are as strong and healthy as those from perfect seed; and they should not be used for seed when it can be avoided.

This insect, though common in all the older States, is almost wholly unknown in Canada, owing perhaps to its not being able to withstand the severity of a Canadian winter. Hence thousands of bushels of peas are annually brought from Canada to the United States, for seed.

Remedies and Preventives.—Late sowing has often proved a successful preventive against the ravages of the pea-bug. If sown the last of May, or first of June, the peas will not blossom or form their pods until after the beetles have disappeared. But peas sown so late often suffer from drouth, and rarely yield a very abundant crop. It is recommended in *Hovey's Magazine* to subject the peas, immediately after they are gathered to the action of boiling water for *one minute*; by this means the larvæ are destroyed, which are at this time just below the integuments of the pea, without affecting the vitality of the seeds. If the peas remain in the boiling water *four minutes*, most of them will be killed. To kiln-dry the peas at a heat of 130 to 140 degrees, will answer the same purpose, and does not destroy the germ. When they are intended for culinary purposes, some such means should be taken to destroy the larvæ.

INTERESTING EXPERIMENT.—In a recent lecture, Mr. NESBIT, Principal of the Agricultural and Scientific Academy, Kensington, London, said:

“A curious circumstance connected with the growth of clover is, that by cutting the clover twice and removing all the hay, a much better wheat crop is obtained than by feeding it off by sheep, even if some artificial food is used. This is owing to the fact that the growth of the roots of clover in the land is in exact proportion to the growth of the leaves in the air. Each leaflet that shoots upward sends a radicle or rootlet downward. *If the leaflet be bitten off or destroyed, its radicle ceases to grow.* It therefore follows that grazing clover by sheep materially diminishes the amount of vegetable matter accumulated in the soil by the roots, and consequently the produce of the succeeding crop.”

The above views are somewhat theoretical, but not improbable. They are sustained by the following experiment:

“A friend of mine in Northamptonshire had a field of clover; it was divided into two portions; both were cut at midsummer, and one part was then fed off with sheep, and the other left to grow till September, when it was again cut and the hay removed. Equal portions of the several pieces were then compared. Where the clover had been cut once and fed off, he got 35 cwt. of clover roots per acre. Where he cut twice, he got 75 cwt.; there being a difference of two tons of vegetable matter per acre.”

If further experiments shall confirm the correctness of the above, it will lead to the mowing of all clover fields, whether the crop cut is fed green or as hay. In wheat culture, a good supply of clover roots to decay and enrich the soil is important. Indeed, it is probable that the close pruning of plants by feeding animals, greatly diminishes the yield of forage in the aggregate.

BUTTER AND CHEESE MAKING.

MILK is composed principally of three substances—curd or casein, butter, and sugar of milk, held in solution by some 87 per cent. of water. The casein is what chemists call a *nitrogenous* compound, and is precisely similar in composition to white of egg, pure flesh, the gluten of wheat, &c. The butter and sugar, when pure, contain no nitrogen, and correspond in composition with fat, starch, and other *carbonaceous* compounds.

Butter exists in milk as *oily globules enclosed by a film of casein*, which being specifically lighter than the milk, gradually rise to the surface when allowed to stand. With these globules, or cream, arises a portion of the sugar of milk; so that in the cream we have the butter and a small amount of casein and sugar. This sugar of milk may be obtained by taking some sweet whey and heating it slightly, adding at the same time a little white of egg. This will precipitate all the curd and butter, which must be removed by filtering through a fine cloth. The whey will be clear and free from all impurities. If it is now poured into an earthen vessel, and placed in a cool place, in a few days small crystals will settle on the sides and bottom of the vessel. These are *sugar of milk*. This sugar may be preserved dry or in solution for a great length of time. But if into a solution there be placed a little curd or rennet, a chemical action immediately takes place, and the sugar is converted into *lactic acid*. The same acid is produced in the fermentation of brewers' grains, cabbage, (*Sauer Kraut*,) and in a number of familiar instances. If the fermentation be allowed to proceed, carbonic acid is given off, and alcohol is formed precisely as in the fermentation of cane and grape sugar.

Now, in the cream we have this sugar of milk in solution in conjunction with curd, the very condition essential to the formation of lactic acid; and we accordingly find that at the proper temperature for fermentation, (from 60 to 120 deg. Fahr.,) lactic acid is produced, and the cream becomes sour. When cream is heated, the oily globules appear to burst their shells and run into each other, rising to the surface in the form of melted fat. Likewise, when cream or milk is agitated for a length of time by mechanical means, the temperature is increased, the films enclosing the globules are broken, and the fatty matter runs together in the form of small grains, and finally into humps of ordinary butter. The facility with which this is accomplished appears to be greatly promoted by the presence of the lactic acid, since it never takes place without becoming slightly sour during the process, even though the cream is sweet when put into the churn. It is always advisable to have the cream sour before churning, as much less labor is required, and more butter obtained than when churned sweet. In cold weather it is often necessary to place the cream in a warm place before the fermentation of the sugar will take place; in other words, before it will sour.

As the result of many experiments, it is now proved that cream should not be warmer than 55 deg. Fahr. when placed in the churn, nor more than 65 deg. when the butter comes. This temperature produces the greatest quantity and best quality of butter. The cream always increases in temperature from 5 to 10 deg. during churning.

The composition of butter differs very much, according to the manner in which it is obtained, the kind of cows, quality of food, and time of year. It consists generally of about 84 per cent. of the fat of milk, or pure butter, and 16 per cent. of water, sugar of milk, and casein; the latter in very small proportion, yet sufficient to produce great changes in the butter, unless means are taken to counteract its transforming influence. We have seen, that in contact with casein, sugar of milk is changed into lactic acid. In butter, therefore, the sugar soon changes into this acid. But that is not all: under the influence of the air, and in connection with butter, further decompositions take place, and *butyric* acid is produced, which imparts a very disagreeable odor and taste to the butter. If allowed still further to decompose, *capric* and *caproic* acids are produced;

and it is to the presence of these three acids, in a greater or less proportion, that the rancidity of butter is owing. The cause, therefore, of butter becoming rancid, is the presence of the nitrogenous compound, casein. The prevention is attained only by considerable trouble and care.

Saturated solutions of saline and other substances are found to arrest this tendency to decomposition. Among them is common salt, which is most generally used for this purpose. It should be as free from all impurities as possible, especially the salts of lime and magnesia, which are found to give the butter a bitter and otherwise disagreeable flavor. These salts, being soluble in less water than common salt, may be got rid of by pouring about a quart of hot water on eight or ten pounds of salt, stirring it well for a short time, and then straining it through a fine cloth. The impurities will go off in the liquor, which may be given to stock, &c., and the salt in the bag can be dried and kept for butter-making purposes.

When the butter is taken from the churn, it is usual either to wash it till it imparts no color to the water, or to press out the buttermilk by kneading and pressing, using no water at all. Both methods have their advocates, and both have certain advantages over the other. The washing doubtless removes most of the casein and sugar of milk, and is, we think, decidedly the best practice. All the water that is left in the butter, be it more or less, must be *saturated with salt*; that is, must have dissolved as much as it is capable of taking up: so that it is necessary to free the butter from all the water possible, or else it will be too salt. We insist particularly on this point, because it is proved by experience that butter, however good it may be when packed, will not keep if there is any water, or buttermilk, or curd, that is not well saturated with salt. It is also necessary to exclude the atmosphere as much as possible from the butter, its oxygen greatly facilitating decomposition.

Of the great necessity of cleanliness in every operation connected with the dairy, it is unnecessary to remark, further than that cream is remarkable for the rapidity with which it absorbs different gases; so that great care should be taken to keep the dairy clean, and close all apertures through which any offensive gases might enter.

The chemical changes that take place in the manufacture of cheese, are very similar in their nature to those just described in our remarks on butter-making, and can easily be understood.

When milk is first drawn from the cow, it is always *alkaline*, in consequence of the soda contained in it. If to a portion of this milk vinegar or any other acid be added, the milk is immediately curdled. When in this state, if a little soda or potash is added, sufficient to make the mixture slightly alkaline, the curd disappears, and the milk is restored to its original state. The reason for these changes is, that curd is insoluble in pure water, or in water containing an acid; but is soluble in water containing an alkali—soda, potash, or ammonia. Now, milk contains soda, which unites with the curd, rendering it soluble; but when an acid is applied, it unites with this soda, neutralizing its alkaline properties, and the curd is left in an insoluble condition, or is precipitated. When milk is kept for any length of time at a temperature favorable for fermentation, a chemical change takes place—the sugar of milk, under the influence of the casein, is transformed into lactic acid, which unites with the soda, taking it away from the curd, and thus leaving it in an insoluble state, or precipitates it in the same manner as though vinegar or some acid had been added.

The various processes of cheese-making are only different modes of *hastening* this decomposition of the sugar into lactic acid, and arresting it at the proper time. The one generally adopted in this country—using the prepared stomach of the calf or hog—is doubtless the best method at present known. Of the action of rennet, there is much ignorance, and consequently much diversity of opinion. From the fact that gastric juice will immediately curdle milk, it was very reasonable to suppose that the action of rennet

was caused by gastric juice retained in the stomach. This opinion, however, is not sustained by any facts but what apply with equal force to the theory we have adopted, while there are many inconsistent with it. The gastric juice is often entirely removed by well washing the stomach several times in water, and afterwards soaking it in a saturated solution of salt and water for several months, after which it is sometimes washed, and then salted and dried for use. By this process the gastric juice could not possibly be retained in the rennet. Were it the gastric juice, it is but reasonable to suppose that the fresh stomach would be stronger and better than the ones thus prepared and kept for a length of time. But this is not so, rennet not being considered fit for use till at least twelve months old; and though it will do earlier, yet much more is required to "set the cheese." Does the gastric juice increase in quantity or in quality by keeping? or must we look for another theory?

It will be remembered that we said, that if to a solution of pure sugar of milk, that would not of itself undergo decomposition, a little curd or rennet was added, the sugar was gradually converted into lactic acid. Now, in milk, this curd is present in conjunction with the sugar, and the change will of itself gradually take place; but it is desired to accelerate it, and accordingly rennet, which is a *soluble highly nitrogenous ferment* that can easily be intimately mixed with the whole of the milk, is added for this purpose. It quickly converts the sugar into lactic acid, which unites with the soda, forming a neutral salt, (lactate of soda,) and the curd is left in an insoluble state.

The reason for raising the temperature of the milk, is to assist the rennet and lactic acid, and also, when the curd is precipitated, of condensing its particles by coagulation, rendering them more easy of separation from the whey. The proper temperature at which the rennet should be added to the milk, is about 95 deg. Fahr., experience proving this to produce the best quality of cheese. In making skim cheese, however, the milk should be set a little cooler, otherwise the curd is apt to be tough and sour. There are various ways of heating the milk to the proper temperature. In a small dairy it may be done by placing a tin of milk in boiling water, and when it is hot, pouring it into the cheese vat. In a large dairy, a boiler should be so constructed as to be surrounded with water, similar to an ordinary glue pot. This would prevent the possibility of injury from overheating, &c. It would be very advantageous not to heat any portion of the milk hotter than 95 deg., but in some way increase the whole of the milk to that temperature; but we know of no method of doing this, though probably some of our ingenious dairymen will hit on one ere long that will cheaply accomplish the object by means of steam passing through a worm placed round the cheese vat. The objection to heating a portion of the milk to a high temperature, is that the butter it contains runs together in an oily mass, which is very apt to get pressed out of the cheese when afterwards subjected to a high and necessary pressure.

We have said that butter exists in milk in the form of globules encased with a shell of curd. When the curd is rendered insoluble by the formation of lactic acid, these globules combine more or less with the curd, and are intimately mixed with it. We are not acquainted with any experiments that have been tried as to the relative amount of butter left in the whey after the curd has been removed, by different processes, at different temperatures, &c. It is, however, well known that in the making of cheese from new or unskimmed milk, considerable butter is left in the whey, which in many parts of Europe is obtained by placing the whey in large vessels for a day or two, when cream will rise to the surface, which is taken off and churned. Much labor is required in churning, but considerable butter is obtained, having a peculiar sweet and cheesy taste, arising from the large amount of curd and sugar of milk which it contains. It must be used fresh, as it is next to impossible to keep it, for the above reason. In England, where it is called "whey butter," it sells for about 30 per cent. less than the best milk-cream butter.

The great difference in the quality of cheese made in different districts, is doubtless owing more to the processes of manufacture, than to the kind of cows and the nature and quality of food. The kind and quantity of rennet, the temperature at which it is added, the quality and quantity of salt, and the manner in which it is applied, the pressure to which it is subjected, and the temperature of the drying-room, all materially affect the quality of the cheese. We prefer salting the curd as soon as it has been pressed a little, and a great part of the whey removed. It should be crumbled up as fine as possible, and the salt (which should be free from impurities,) be mixed as intimately as possible. All the whey and water in the cheese must be saturated with salt. Hence it is that a large cheese, from the greater difficulty of pressing out the whey, requires more salt proportionably than a small one.

It is necessary to continue the cheese under the press as long as it will wet the cloth surrounding it, which must be removed and replaced by a dry one. The cheese should be kept in the dairy, or other cool place, for some time before it is removed to the drying-room. While in the green state, it is sometimes covered with salt for a short time.

The reason of cheese swelling, or being huffed, is owing to adding too much rennet, or rennet that is too strong, being too much decomposed. Leaving whey in, or any animal fluid, will produce the same effect. Salt may be added in sufficient quantity to counteract its decomposing influence, but the cheese in this case will be hard and unpalatable.

The drying-room should be dark, but well ventilated. The cheeses must not touch each other, and should be turned often, especially when green, or they will mould on the side next the floor. It is customary to grease the cheeses repeatedly during drying. It is said to improve the appearance of the cheese, preventing its cracking, &c.

One of our lady subscribers informs us that the cheese fly is a great trouble to dairy farmers, especially at the west; and that a *strong decoction of Sweet Elder*, rubbed on with the butter, keeps the flies away, and at the same time improves the flavor and color of the cheese.

FARMING IN KENTUCKY.—In soliciting subscribers, I am frequently met with the objection that your paper is not adapted to our system of farming, and that those articles upon the subject of manuring and making manure, which frequently appear in your columns, are not at all practicable in Kentucky. And this is true. But we have a system of farming, which is necessary to keep our lands in the most fertile condition; yet there is nothing done the *primary* object of which is to make manure in the barn-yard or manure-heap; but we have adopted a system of rotation in crops, and by this means our lands are kept up. I would suggest to you the propriety of securing a Kentucky contributor, to answer this objection. ELI M. KENNEDY.

No system of rotation enabling the farmer to keep his land in good heart and obtain good crops, can be condemned; yet we are unable to conceive such a system without in some way or other returning a portion of the elements which plants contain, in the shape of manure or green crops. It is a proposition as true in agriculture as in domestic economy—"Always taking out of the meal tub, and never putting in, soon comes to the bottom." What we contend for is, that the annual exportation, in the form of cotton, tobacco, wheat, corn, &c., of phosphate of lime, potash, soda, and other elements which exist in the soil only in small quantities, *must ultimately impoverish the soil*; and that, though by plowing in clover, &c., the crops are greatly increased, yet if these large crops are all exported from the farm, such a system can not long be adopted without seriously injuring the soil. What we advise is, not that large crops should not be grown in any way possible, but that care be taken in time to restore, in the form of manure, those important elements which are so essential and at the same time so liable to be exhausted by a thoughtless, wasteful system of culture.

We should be glad to hear from our friend how the farmers manage their lands, obtaining good crops without manure, or in *some way* furnishing the necessary elements in a proper state for assimilation by the plants.

Communications and Editorial Notes.

UNDER the above head we give a number of letters, with editorial notes, some of them received just as we were going to press, and requiring answers previous to the issue of our June number.

LICE ON CATTLE.—We have received several inquiries as to the best means to get rid of lice on cattle. Grease or oil will kill them, buttermilk or whey they do not like, and fine sand thrown over the animal removes them. A decoction of cedar bark or tobacco is also recommended by some, and Scotch snuff by others.

(A Subscriber, Montgomery City, Pa.) **GUANO.**—Previous to sowing, the guano should be passed through a sieve, to take out all the lumps, which must be broken fine, till they will pass through the sieve. Unless this is done, the lumps destroy all vegetation where they fall. It should never be placed contiguous to seed, but should be well mixed with the soil near it. In using it for corn, it is convenient to sow it just as the corn is up, and cover it with the hoe. If, however, it could be sown and mixed with the soil in the hill previous to planting, we should prefer it, as it then gives the corn a better start. From 200 to 400 lbs. per acre may be sown. It will increase the crop considerably, but whether sufficiently to pay for the application at the present price of guano and corn, we do not know, though we are afraid it will not. Please send us the result of the application.

BOG LIME.—I have an acre and a half of bog lime, or shell marl, and I would much like to know its value and the proper method of using it to the best advantage. I find, when burned, it forms a substance white as chalk. Now, if you, or any of your readers, can inform me whether it is prudent to use it as a fertilizer in its crude state, or whether it must undergo some certain process before using, I shall be much obliged. J. A. G.—*Hillsdale.*

It is impossible to judge correctly of its value, without some knowledge of its chemical composition. Is there much organic matter driven away in burning? Does the white substance left as ash effervesce on the addition of vinegar? If so, it is probably chalk; but there may be alkalis and phosphates united with it that would make a very valuable manure. We would use some in the crude and some in the burnt state, before making extensive application of it.

MANURE DROPPED IN SUMMER.—Will you give information through your valuable paper, respecting the use of manure dropped in the yard or elsewhere. I pick it up in the morning, and immediately cover it with loam or some other material that takes up the moisture, so that it will not escape into the atmosphere. I wish to know which is the best mode of using it. Shall I haul it out in the fall, and plow it under; or heap it up till spring, and then plow under? A SUBSCRIBER.

In the fermentation of dung, there is given off water, carbonic acid, and carbonate of ammonia. The loss of water, of course, is of no consequence, and if the manure is used for wheat or corn, the carbonic acid is of little value. But the carbonate of ammonia is *the grand fertilizer* for all our cereal grain crops, and it is particularly needed on all wheat farms. If this is retained in the manure, the more it is fermented the better, as there is then less bulk to cart, spread, and plow under, and the mineral elements are probably rendered in a better state for assimilation by the process of decomposition. To retain the ammonia is the great difficulty; for as it is much lighter than atmospheric air, it is very prone to take to itself wings and fly away, leaving the manure a comparatively worthless mass. The heap should never be suffered to get hotter than blood heat; and then if it is covered with loam or other absorbent substance, and is not drenched with rains and the rain water from the buildings, most of the ammonia, and soluble phosphates, and alkalis will be retained, which will act quick, and would therefore be most beneficial if applied to spring crops.

STALL FEEDING SHEEP.—Will you inform your readers what is the best mode of stall feeding sheep, so as to fatten them readily? Some six weeks ago, I shut up some, and fed them with shelled corn, ground corn, and good hay, as much as they would eat; and I believe they grow poorer every day. A YOUNG FARMER.—*Napoleon, Mich.*

Nothing is so good to fatten sheep as oilcake or peas and beans and good clover hay. A good sheep, weighing about 150 lbs., will eat about 3 lbs. of clover, and 1 lb. of oilcake per day, and increase about 2½ lbs. per week. A few roots, either of ruta бага or mangel wurzel, are of great benefit. Corn is not so good to fat sheep as oats or barley. But oilcake and peas are best, not only because they fatten quickest, but leave much the most valuable manure. See the article on Peas in this number.

TO DISSOLVE BONES.—As you give subscribers the liberty to ask questions, I wish to ask how many pounds of potash will it take to dissolve one bushel of bones, that they may be mixed with other substances and applied to root crops in the hill? or can it be done by strong lye? or what is the best and cheapest way to apply bones to the soil? We have no bone mill in these parts. LOTT PARSONS.—*South Amherst, Ohio.*

Make a strong lye, as in soap making; then boil bones in it till they fall to a powder—the lye consuming the gelatin. We cannot give the exact relation that a pound of potash bears to a pound of bones. This is one of the many things that an experimental farm would teach; but we are nearly discouraged in trying to get such an institution started in the United States. Anything designed to increase our knowledge of rural economy, in a common sense practical way, is successfully opposed.

SUPERPHOSPHATE OF LIME AND MANGEL WURZEL—Can you inform me if the Shaker seed marked "Mangel Wurzel or Sugar Beet," is the kind you recommend in the March number? Where can the superphosphate of lime, of good quality, be obtained; and what is the price? SILAS H. MEACHAM.—*Richland, N. Y.*

The sugar beet and mangel wurzel are different roots, and seed of either can be obtained from any respectable seedsman. The superphosphate of lime is being manufactured by the New Jersey Zinc Company, and is for sale in New York City at 2½ ets. per lb. We think superphosphate of lime is an excellent manure for root crops, and were in hopes it could have been manufactured at a price sufficiently low for its profitable use as a manure. It can be purchased in England for \$35 per ton, and an article manufactured from Coprolites, or a mineral phosphate of lime, is sold for \$24 per ton of 2240 lbs.

TREATMENT OF SANDY SOILS.—Having much confidence in the correctness of your opinion upon agricultural matters, I write to you for advice in regard to the treatment of a sandy soil, which, at a depth varying from five to eight inches, is underlaid with a mixture of sand and iron, usually hard, but sometimes in a pulverized state. This subsoil is sometimes of a very dark color, and sometimes of a reddish hue. Shall I turn this subsoil to the surface, loosen it with a subsoil plow, or let it be as it is? Would it pay to apply lime at fifty cents per bushel? This land, if treated with twenty-five or thirty loads of compost, two-thirds swamp muck and the rest stable manure, would yield from twenty-five to thirty-five bushels of corn. II.—*Valley Farm, N. H.*

A very little of the subsoil may be brought to the surface and incorporated with the sandy surface soil. It will hardly pay to give fifty cents a bushel for lime to apply to land; but a little may be mixed with swamp muck to sweeten it before manure is added to it in forming compost heaps. Ashes may also be used to correct the sourness of muck, or other vegetable matter.

SWEET POTATOES.—I made an attempt, last summer, and succeeded in raising a reasonably good crop of sweet potatoes, but failed entirely in keeping them through the winter. I packed them in dry wheat chaff, and put them where they did not freeze. I examined them about the 16th of December, and found them all rotten. If you can let me know, through your paper, or otherwise, how to keep them, you would oblige me, and perhaps others. A. H. ALLEBACH.—*New Bethlehem, Pa.*

Condensed Correspondence.

WINTER BARLEY.—I saw in a late number of the *Farmer*, the subject of raising barley introduced, and I believe the kind spoken of to be the spring variety. I have now growing over forty acres of the winter variety, which looks well. In the fall of 1850 I procured three and a half bushels of seed from Ohio, which I sowed on two acres of land, and the yield was 140 bushels, or 70 bushels per acre, of a very superior article, weighing 52 lbs. per bushel, scaled measure. I have sown nearly ninety bushels, or about two bushels per acre, and the balance sold readily for one dollar per bushel. I hope to exhibit a sample at your State Fair this year. B. S.—*Logansport, Ind.*

GRUBS ON MELON VINES.—Year before last I was greatly annoyed by a grub that for several weeks made a deadly onset upon my melon vines; and after resorting to almost every stratagem that I could hear of to keep them away and preserve my vines, I finally resolved upon an extreme course, as I thought. So I went to a kettle where soap had been recently made; the kettle not being covered, rain water had fallen in it, and the stench arising from it was very offensive. The sediment was composed of bone dust, the bones having been boiled in lye till they were reduced very fine. After saturating the hills thoroughly with this sediment several times, I was not annoyed by the worms after. But that was not all the good resulting from it, for it acted like a charm on the vines, and it was never my fortune to raise such a fine crop of melons before from such a small number of vines. J. D. C.—*Locke, N. Y.*

RECIPE FOR CURING SORES.—Take two and a half drams of blue vitriol, four drams of alum, and six drams of loaf sugar; or, we will say, blue vitriol the size of a walnut, alum a size larger, and sugar the size of a hen's egg. Pulverize, and turn into a glass bottle. Add one pint of good vinegar, and one table-spoonful of honey. Cork, and shake the mixture three or four times a day; and when dissolved, it is fit for use.

This wash will remove film from horses' eyes; will cure king's evil and most kinds of fever sores; will destroy proud flesh, and cause the sore to heal. It is great for hoof-rot in sheep, and may be applied to any sore with safety. The sore should be kept clean, and washed twice a day with the mixture, till completely healed. For the eyes it may be diluted with soft water one-half, but should in all cases be used as strong as the patient can bear. For hoof-rot in sheep, add as much gunpowder as vitriol; pare away all the affected part of the hoof, wash freely every few days, turn the sheep into a fresh pasture, and you have a cure. R. R.—*Center Lisle, N. Y.*

POTATO CULTURE.—If convenient, break the sod in the fall; if not, as early in the spring as possible. Spread a good coat of old manure, and plow it in; let the turf lie fifteen or twenty days; if rough, roll and cultivate it well; and plant as early as the weather will permit. I always cut my potatoes. Have planted them in drills and in hills—three or four setts in a hill. As soon as four leaves are seen, I always go through them with a cultivator, and stir the earth at every sett. When six inches high, I go over them in the same way; and again when one foot high. I go through them twice in each row with a plow. I give them a good, but a flat hill. In July my potatoes are fit to dig. I plow the soil in narrow lands, not more than three rows on a land, with a good furrow between kept well hoed out. I have raised potatoes in this place for nineteen years, and have never had the rot or bugs injure them. This I think is because I plant so early—generally in March. I think that potatoes are struck with the disease by an east wind; I have found that where they were planted on the west or south side of a hill, they were not injured. N. L. C.—*Geneva, Ashtabula Co., Ohio.*

VIRGINIA LAND.—Three years ago I purchased a farm here of 300 acres for \$3 per acre. The improvements on it consisted of a comfortable frame dwelling house and out houses. More than half the land was in woods of heavy growth of timber. Only three small fields had ever been cultivated to any extent, and there were two fields that had been cultivated for one or two years only; and yet this land had been in market five or six years, at \$2.50 per acre. The owner asked me \$3, and I did not hesitate a moment to give it. Last summer several thousand acres of unimproved lands, entirely in the woods, were sold to citizens of the county, old men, bred and born here, at from 10 cents to \$2 per acre. Some of my neighbors who have comfortable homes, good tracts of land well

inclosed, with a good proportion of river and creek bottoms, and orchards of fine fruit, &c., around them, are starting to the southwest to look for richer land! Any one of these tracts "I guess" could be bought for from \$6 to \$8 per acre. If they were mine, I would not take double what they ask, and what they will be obliged to take, if they "move" as they expect.

I am thus particular to mention these facts, because I observe there is an increased interest to know more about Virginia and Virginia land, and because I wish to see men of enterprize, intelligence, and industry, settling in the "Old Commonwealth." I have no other interest to advance by it, except the cause of agriculture, and a hope of one day seeing my children in the midst of a refined, civilized, and enlightened community. G. A. WALKUP.—*M. Airy, Pittsylvania Co., Va.*

WHITE BEANS.—You have often requested your subscribers to communicate to the *Farmer* their experience in raising different kinds of crops. I have seen no notice on the culture of the white bean, and as some farmers are turning their attention to this crop, it may be of advantage to some to know how I manage. I do this work the last week in May. I prepare my ground by plowing and dragging smooth; I mark it out in shallow furrows, about two and a half feet apart, with a corn plow; I then drop the beans two or three inches apart in this furrow. I use a drag that is wide enough to cover two rows at a time. In this way, with two hands, I can plant four acres in a day. I find this a better way than to plant in hills. When the beans are about three or four inches high, I go through them with the cultivator; weed, and hoe them well. When about ten inches high, I use the corn plow, turning the soil against the vines to hold them up. This time I use no hoe. By this process, and with a sprinkling of plaster when I hoe them, I raise from twenty to twenty-five bushels per acre. The past season I had four acres, from which I measured up ninety-one bushels. When I gather and thresh them, I save the vines to feed to my cattle. I have kept seven head this winter, and have fed but little else. *They are all in good order.* J. B. HART.—*Caudor Center, N. Y.*

HEDGES.—Much has been written about hedges in my time, by theorists; but one grain of experience with me is worth a pound of theory. Of all plants for hedging, and I have tried seven or eight varieties, I find the English Hawthorn the best. Privet is only fit for an ornamental hedge, and so with Box; Buckthorn too slow forming an effectual barrier; Hazel too tempting to boys; Holly too slow; the Rose too weak; and the Osage Orange too tender and weak for our northern latitude. The Hawthorn is hardy, and after two years' growth can support any snow that may happen to lodge on it. It is a rapid grower; adapted to most soils, but thrives best on a clay bottom. I have them three years old, an inch in diameter and ten feet high. I have them, too, on high and low land, on stiff clay, on bog, on sand, and on good loamy land; and can see but little difference.

A thorn hedge may be planted any time from the middle of October to middle of May, (provided the ground is free of frost,) in clean ground free from weeds. The land should be properly graded, and where it is low or wet, should be raised, as the thorn is not a water plant; but at the same it does not require a ditch, as in Europe. The plants should be set perfectly upright to make a good hedge, and require, under the best management, to be protected from cattle, &c., for three or four years; though I have one hedge only three years old that is fit to throw open the coming summer. I cut down either at the time of planting or one year therefrom, after which I only side trim, allowing the lowest lateral branches to extend eighteen inches from the stock, gradually narrowing to the top. This makes a stiff, close fence, that will obstruct any unruly animals.

Much has been said against the Hawthorn as a hedge plant. The reason is, that those who cavil on the point are those who have barely a theoretical knowledge of its habits. The Thorn is liable to all or most of the diseases of the apple tree, and no other. Where one thrives, there will the other thrive; and no fence is better calculated to prevent depredations on fruit trees. The Apple and Peach are subject to diseases; but should they be shunned on that account? That the Thorn may do better in some locations than in others, I do not deny; but of this I am certain, that I have seen no plant more congenial for hedges in Onondaga county, than the Hawthorn. M.—*Onondaga, N. Y.*

FARMING IN EDGAR COUNTY, ILLINOIS.—If you will look at the map of Illinois, you will see that Edgar county lies on the eastern line of the State, about midway between the northern and southern boundaries. Paris is within ten miles of the State line, and eighteen of the Great Wabash river; consequently we have no nearer market than Terre Haute, Ind., twenty miles from Paris.

Our principal products are corn, oats, and wheat. Corn averages about sixty bushels per acre, and is worth 15 to 18 cents per bushel at home. There are but few sales, and it is mostly fed to hogs,

cattle, and horses. Oats are a good crop, averaging forty-five bushels per acre, and are worth in Paris 12½ cents per bushel. There is little demand for them. Wheat is a very uncertain crop, on account of freezing out; but last year we had a fine crop in this county. It sells at home for 40 to 45 cents, and in Terre Haute, Ind., 50 to 55 cents per bushel. Prospects tolerably good for the coming crop. Wheat sown on clover sod, oat stubble, or prairie sod, is more certain to hit than on any other ground in this prairie country. The Mediterranean wheat does not stand the winter so well, and is more liable to rust than the smooth wheat, which yielded last year twenty bushels per acre. There is difference of opinion respecting the best quantity of seed to sow—about six pecks is perhaps the average. I think this is not sufficient, and sow one and half bushels. Corn is our staple produce, having a greater demand for it than for oats, on account of feeding out to cattle and hogs. Farmers seldom raise more wheat than they require to make bread for their own family, and oats for feeding calves and sheep. The farmer that has 200 bushels of wheat, is looked upon as a great wheat grower. As to stock, the mule, hog, and steer, is about all that is raised here. A mule two years old is worth from \$60 to \$65; a steer four years old, \$18 to \$20; and hogs are now worth 2½ cents per lb., gross, and sold here last winter, fatted, at \$4.25 per hundred. Potatoes sufficient for the family's own consumption only are raised, though we have never had the potato rot in these parts. But little rye or barley is grown, no flax or hemp, and but little buckwheat, the farmers thinking it hurts the ground. For threshing wheat, we pay \$5 per hundred bushels; and for oats, \$3. *All cash for pay.* D. J. CONNEY.—*Paris, Ill.*

LARGE AND SMALL POTATOES FOR SEED.—In some former numbers of the *Farmer* I have observed a difference of opinion in reference to the selection of potatoes for seed, some contending for large whole potatoes, some for large ones cut, and others that small ones are equally as good, if not better. Now, my own views have been, and still are, that like produces like; or, that every thing in nature brings forth after its kind; and not only after its kind, but also, as a general principle, after its quality; and in order to improve either animal or vegetable, we must propagate from the best specimens to be obtained, potatoes not excepted. This I think is a correct theory, agreeing with my experience, and corroborated by the following experiments:

A few years since, I tried an experiment with large and small potatoes for seed. The result was nine bushels from the small seed and twelve from the large, all other things being equal. Subsequently I tried the relative value of large and small potatoes for seed, in connection with an experiment with and without plaster. I selected four rows through the field, which I planted and harvested in the following order: No. 1. Large whole potatoes, plastered; harvested seven bushels. No. 2. Large whole potatoes, not plastered; harvested four bushels and twenty-eight quarts. No. 3. Small seed, plastered; harvested five bushels. No. 4. Small seed, not plastered; harvested three bushels and twenty quarts. This, as far as my observation extends, is about the average benefit of both seed and plaster. DANIEL LOTT.—*Lottsville, Pa.*

I believe it has long been a mooted point among *practical* farmers, whether large or small potatoes are better for planting. Circumstances, it is true, may favor the one or the other position, according to the experience of different men. The simple theory, respecting the matter, I have never seen advanced by any writer upon the subject. The error in the reasoning lies, I think, in the assumption that the potato itself is the seed. If this were true, we might indeed think the potato a single exception to the universal law that "like begets like." But the potato is not a seed, and therefore not an exception. It is simply a root, propagated—not by reproduction, but by continuation; and the only advantage which I can conceive the large has over the small potato, is in the nutriment its greater bulk would supply to the germ. If this reason is satisfactory, we hope small potatoes may hereafter be regarded as of some value, and at least be preserved for planting in times of great scarcity. Our farmers in this quarter may be signally benefitted by practicing upon the above hint, until our potato harvests shall be more propitious. J. A. PRESTON.—*Hartland, Wis.*

COMPOST MANURE.—I have about thirty acres of peat, or vegetable mold, on my farm. About five years ago I took six loads of it, mixed it with leached ashes and plaster, let it lay a year and turned it once. I applied it to grass land in very low condition. The result was, I have taken eight crops of hay in four years, and three times as much to each crop as the year previous to its application. I have used the compost in the hill with broom corn, by the side of barnyard manure, and the same quantity of ashes and plaster in each. That dressed with the compost was about a week forward of the other when the brush came out, and the seed was worth double. HIRAM ROOT.—*Deerfield, Mass.*

CHINESE HOGS.

This breed of swine has long been known in Europe and America, and has done much to improve our native breeds. The celebrated Berkshire hog owes some of his best points to an intermixture with the Chinese; and it is easy to trace the distinguishing characteristics of the Chinese in all our best breeds of swine. There are some seven varieties, or at least several kinds of hogs that are called "Chinese," produced by different climates, habits, &c. The kind most generally kept in Great Britain is a small, black, short legged, quiet looking animal, with fine, small, stand up ears; short snout; thin skin; and a round, compact, fine muscled body, with scarcely any bones, and very little hair. They are much prized on account of early maturity, the rapidity with which they lay on fat, and the small amount of offal and bones. They make first rate "porkers," but are rather too small to be much valued as "bacon" makers. But crossed with some of the larger breeds, such as the Yorkshire, a breed is obtained second to none. At the last New York State Fair, J. DELAFIELD, Esq., the President, exhibited for show only, two fine specimens of this breed, a cut of which is here given. They are

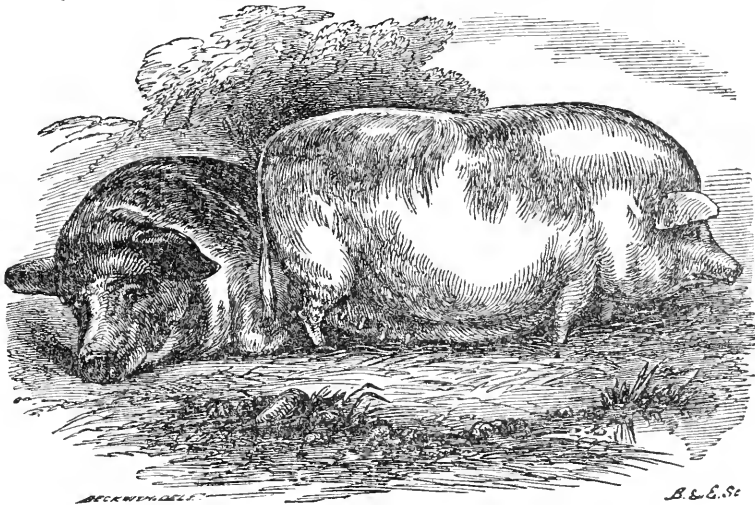

CHINESE HOGS.

exceedingly prolific; one of these here delineated was suckling thirteen at the time of the Fair. It is amazing with what rapidity the little fellows grow, if well kept in a clean warm sty. We saw some at the Smithfield Cattle Show, that were apparently nothing but balls of fat, with scarcely legs, eyes, or mouth visible. It is generally admitted there, that this breed will lay on more fat from a given amount of food, than any other; and we think it will be greatly beneficial in improving our present race of swine.

We intend giving our views on the best means of fattening hogs, in a future number. During the summer they should be allowed to run in a clover field, and have access to plenty of water. They should also be fed *regularly* with the whey, butter-milk, and other wash from the house, three times a day. They ought to have plenty of food, and be half fat when put up on corn in the fall.

Mr. LOVEJOY, of Canaan, N. Y., informs us that he killed a hog the last winter, *only nine months old*, that weighed 411 lbs. when dressed. We do not know what breed it was, but think if the Chinese hog can lay on fat much quicker than this, or at the rate of $11\frac{1}{2}$ lbs. per week, it is all that we have asserted.

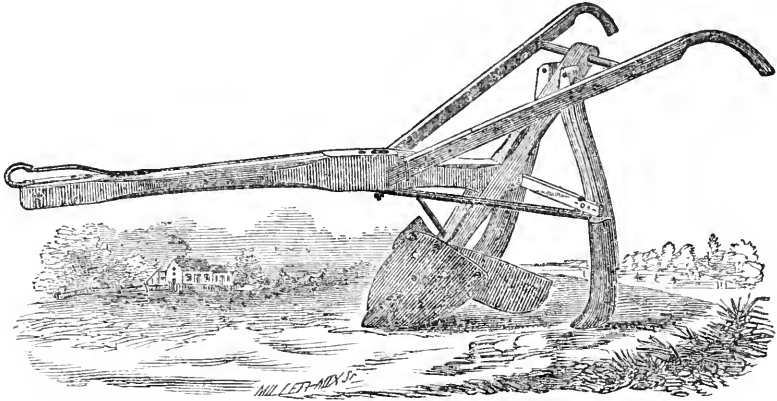

WRIGHT'S PREMIUM HORSE-HOE.—The above engraving represents Wright's Horse-Hoe, to which was awarded a premium at the last State Fair. We think this will be found a valuable implement, as we have used one somewhat similar, though apparently a poorer implement, with the operation of which we were much pleased. The inventor says it "is so arranged that it can be used between rows of any width from two to four feet apart, and can also be governed as to the depth by raising or depressing the wings or hoes. The earth can be removed from the crop when small, or billed up in its more forward state. In other words, the operator can perform all that is necessary to insure a good crop of corn, potatoes, &c., without the aid of hand-hoeing, provided the directions accompanying each machine are followed." For further information, see advertisement in last number.

MUMMY WHEAT.—We give an exact drawing of a head of Mummy Wheat, furnished us by a gentleman whose name we regret that we can not state, from the circumstance that his letter was mislaid by the artist. Some samples of this variety send out several short heads, being probably the same "corn" referred to in the Bible as "seven eared." This grain is cultivated to some extent in the territory of Utah, from seed recently brought from Egypt. We have seen specimens from Utah, that had five ears or heads growing from one stem. No satisfactory evidence has come to our knowledge, of any peculiar value in Mummy wheat. As a curiosity, it is worth cultivating.

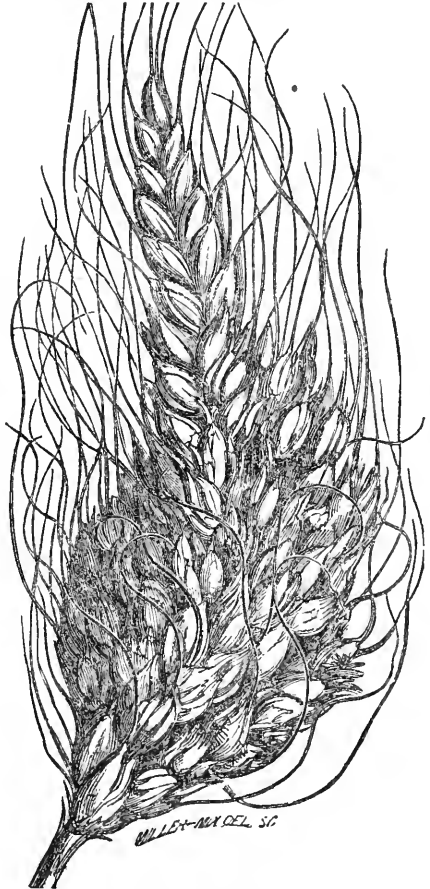

MUMMY WHEAT.

Horticultural Department.

CONDUCTED BY P. BARRY.

THOSE who are in the habit of perusing the agricultural and horticultural journals, must have observed that every year, and indeed every month, the subject of preparing and applying fertilizers of the soil, assumes more and more importance. In all the older States the primitive fertility of the soil is becoming exhausted, and people are finding out in the declining produce of their fields and gardens, that they must either apply manures or move further back. Twelve years ago, in the city of Rochester, manure—good stable manure—could be had in abundance for nothing. Thousands of loads were annually emptied into the river. Now it commands twenty-five cents a two-horse wagon load, at least; and that in a fresh, rough state, as it comes from the stable floor. Every year it grows dearer and scarcer, although the land has not increased, while the quantity of manure produced annually has more than quadrupled.

This shows the growing importance of manure here; and it is so in other places. Patent manure and poudrette companies, and searches after fertilizers in the bowels of the earth, are all so many proofs that we are no longer ignorant of the value of manures; and proofs, too, that a better system of culture is rapidly gaining ground. It is a fact that every man who cultivates a field, an orchard, or a garden, should remember well, that to be successful, he must understand the making as well as the application of fertilizers. Without it he can not produce a remunerating crop on his farm, nor fine fruits or flowers in his garden. Our object at this time is not to discuss the subject in a general way, but to point out now, at the commencement of the growing season, a mode of fertilizing more particularly applicable to the garden, although in other countries practiced extensively on farms, as will presently be seen.

It is well known that manure, before it is in a proper condition to be taken up by the roots of plants, must be in a state of solution. When solid barn-yard manure is applied, it remains ineffective until the moisture of the ground and rains dissolve it. But in this country we often have dry summers, during which manures often remain solid during the whole season of growth, and turn up in the autumn almost as fresh as when turned in; the plants, meantime, starved. In such a climate, it is evident that old, well decayed manure, will be the most effectual; and if in a *liquid state*, better still, in all cases where we wish a rapid and luxuriant growth, as is the case with most garden vegetables and other annual plants. It supplies the place of both rain and manure—essentials of good growth. The liquid manure tank will become an indispensable adjunct to every American garden. The subject is attracting great attention even in the rainy climate of England, and we extract the following from a late number of the *Gardener's Chronicle*, offering some important suggestions in regard to the proper mode, and proper periods in growth, of applying it to the best advantage:

“The great importance of the *Liquid Manure* question, and the numerous inquiries made of us as to the application of this fluid, lead us once more to resume the subject, restricting ourselves on the present occasion to a single point, namely, the period in the growth of a plant when it may be most advantageously applied, or should be altogether withheld.

“In order to understand this part of the question, it must be borne in mind—1, that *liquid manure* is an agent ready for immediate use, its main value depending upon that quality; 2, that its effect is to produce exuberant growth; and 3, that it will continue to do so as long as the temperature and light required for its action are sufficient. These three propositions, rightly understood, point to the true principles of applying it; and, if they are kept in view, no mistakes can well be made. They render it evident that the period in the growth of a plant, at which it should be applied, depends entirely upon the nature of the plant, and the object to be gained.

“If, for example, *wood* and *leaves* are all that the cultivator desires to obtain, it will be evident

that liquid manure may be used freely from the time when buds first break, until it is necessary that the process of ripening the wood shall begin. Wood can not ripen so long as it is growing; wood will continue to grow as long as leaves form, and its rate of growth will be in direct proportion to their rate of development; therefore, in order to ripen wood, growth must be arrested. But the growth of wood will not be arrested so long as liquid manure continues to be applied, except in the presence of a temperature low enough to injure or destroy it. Hence it is obvious that liquid manure must be withheld from plants grown for their wood and leaves, at the latest, by the time when two-thirds of the season shall have elapsed. To administer it in such cases towards the end of the year, would be to produce upon it an effect similar to that caused by a warm wet autumn, when even hardy trees are damaged by the earliest frost.

"In the case of *flowers*, it is to be remembered that the more leaves a plant forms, the fewer blossoms in *that season*; although perhaps the more in a succeeding season, provided exuberance is then arrested. The application of liquid manure is therefore unfavorable to the *immediate* production of flowers. It is further to be remarked, that even although flowers shall have arrived at a rudimentary state at a time when this fluid is applied, and that therefore their number can not be diminished, yet that the effect of exuberance is notoriously to cause deformity; petals become distorted, the colored parts become green, and leaves take the place of the floral organs, as we so often see with roses grown with strong, rank manure. In improving the quality of flowers, liquid manure is therefore a dangerous ingredient; nevertheless its action is most important, if it is rightly given. The true period of applying it, with a view to heighten the beauty of flowers, is undoubtedly when their buds are large enough to show that the elementary organization is completed, and therefore beyond the reach of derangement. If the floral apparatus has once taken upon itself the natural condition, no exuberance will afterwards affect it; the parts which are small will simply grow larger and acquire brighter colors; for those changes in flowers which cause monstrous development, appear to take effect only when the organs are in a nascent state—at the very moment of their birth. Hence it is clear, that in order to affect flowers advantageously by liquid manure, it should be given to plants at the time when the flower bud is formed and just about to swell more rapidly.

"With *fruit* it is different; the period of application should there be when the fruit, not the flowers, are beginning to swell. Nothing is gained by influencing the size or color of the flower of a fruit tree; what we want is to increase the size or the abundance of the fruit. If liquid manure is applied to a plant when the flowers are growing, the vigor which it communicates to them must also be communicated to the leaves; but when leaves are growing unusually fast, there is sometimes a danger that they may rob the branches of the sap required for the nutrition of the fruit; and if that happens, the latter falls off. Here, then, is a source of danger which must not be lost sight of. No doubt, the proper time for using liquid manure is when the fruit is beginning to swell, and has acquired, by means of its own green surface, a power of suction capable of opposing that of the leaves. At that time liquid manure may be applied freely, and continued, from time to time, as long as the fruit is growing. But, at the first sign of ripening, or even earlier, it should be wholly withheld. The ripening process consists in certain changes which the constituents of the fruit and surrounding leaves undergo; it is a new elaboration, which can only be interfered with by the continual introduction of crude matters, such as liquid manure will supply. We all know that when ripening has once begun, even water spoils the quality of fruit, although it augments the size; as is sufficiently shown by the strawberries prepared for the London market, by daily irrigation. Great additional size is obtained, but it is at the expense of flavor; and any injury which mere water may produce, will certainly not be diminished by water holding ammoniacal and saline substances in solution.

"*Root crops* stand in a different position to any of the foregoing. They are most analogous to the first of the above cases; for their roots may be compared to wood, of which they are equivalents. But there is this important difference, that whereas the quantity of wood is in direct proportion to the quantity of leaves, the reverse is the case with root crops. The turnip that throws up an enormous tuft of leaves, has a very small bulb; and so of the carrot. In these plants the root is formed by the leaves; but only when they themselves cease growing vigorously. The true object is to obtain plenty of foliage early enough to afford time for the after formation of the root. This is what happens under ordinary circumstances. The leaves grow rapidly during the warm weather of early autumn; but when the temperature falls, their own development is languid, and all their energy is expended in augmenting the mass below them. We entertain little doubt that by the constant application of liquid manure, a turnip might be absolutely prevented from forming more root than a cabbage. In root crops, what is wanted is an abundant supply of liquid manure when the leaves are forming, so as to secure early a large and vigorous foliage; after which no liquid manure whatever ought to be applied. This is quite consistent with the evidence collected by Mr. DUDLEY FORTESQUE, and published in the Minutes of the Board of Health, to which we have so often of late had occasion to refer. Speaking of Mr. KENNEDY'S farm in Ayrshire, this gentleman says: 'Of the turnips, one lot of *Swedes* dressed with 10 tons of solid farm manure, and about 2000 gallons of the liquid, having six bushels of dissolved bones along with it, *was ready for hoeing ten or twelve days earlier* than another lot dressed with double the amount of solid manure without the liquid application, and were fully equal to those in a neighbor's field which had received 30 loads of farm-yard dung, together with 3 cwt. of guano and 16 bushels of bones per acre. The yield was estimated at 40 tons the Scotch acre, and their great luxuriance seemed to me to justify the expectation. From one field of *White Globe* turnips, sown later, and *manured solely with liquid*, from 40 to 50 tons to the Scotch acre were

expected. A field of carrots reated in the same manner as the *Sweedes*, to which a second application of liquid was given *just before thinning*, promises from 26 to 25 tons the acre.'

"Such we believe to be the principles that should regulate the periods of growth at which liquid manure ought to be given to plants. Those principles are founded upon what appear to be the natural requirements of vegetation—are consistent with all at present known of the subject; and seem to account satisfactorily for many of the failures that are said to have attended the application of this agent. Let us add, however, that they are fair subjects of discussion, and will be all the better understood if subjected to rational criticism. We should therefore be happy to receive the opinions of any correspondents whose *experience* enables them to coincide with, or to differ from us, in this most important matter.

DWARF APPLE TREES.—The dwarf apple tree is now very generally taking the place of the standard, in all tasteful, well managed fruit gardens. A standard apple, covering 30 feet square in a garden, is nothing short of an absurdity; while nothing can be imagined more interesting than the pretty dwarf bushes planted along the borders of a walk, at four or five feet distance. In our treatise, "The Fruit Garden," we have pointed out several eligible forms for these trees, and the modes of producing them; and would now suggest to the tasteful amateur, the vase or goblet form, as represented in the annexed cut. We have given in the "Fruit Garden," pages 233, 234, a detail of this mode of training the peach; and the same principles will apply to the apple: but the latter is much more easily managed, on account of its less vigorous growth. The proceeding is, to commence the head with three or four leading branches. These are kept open in the middle by means of a hoop, and summer pinching is applied to prevent the growth of shoots inside or out. The leading shoots are annually shortened, to produce a sufficient supply of fruit spurs or branches on their lower parts, and to obtain secondary branches, to fill up the spaces that widen as the growth proceeds upward. If summer pinching be not properly applied, there will be a difficulty in having a great deal of wood to cut away at the spring pruning, and consequently a continual production of wood without fruit.

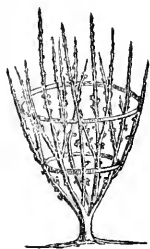

MEMORANDA OF THE SEASON.—Our unusually severe winter cast its cold and gloomy shadow over the whole of March and a considerable portion of April, greatly retarding the ordinary labors of the garden and orchard. Now, on the 17th of April, people here just begin to move in the matters of tree planting and gardening, and everything wears the appearance of March. But we must not complain; for everything looks and promises well. Winter has not been more than usually injurious to vegetation; and we think less so, on the whole, than its predecessor, which was remarkably mild. The ground thawed about the 15th of March; we had then a few fine days, and commenced raising trees in the nursery; but on the 20th it froze hard again, and remained so for a week or ten days. It again thawed, and on the 5th of April we had snow to the depth of six inches. This disappeared rapidly, and we have since had open but cold, showery weather. For a week past it has been rather pleasant; lawns are assuming somewhat of a spring verdure; crocuses are finely in bloom in the garden; buds are swelling fast; and multitudes of laborers, worn out by almost six months' absence of employment, are enjoying the privilege to labor. Never have we seen so many men actually desperate in search of work; it is almost impossible to refuse them. The business of planting trees and improving gardens goes forward in all parts of the country with increased zeal; on all sides we have the most abundant evidences of it.

The publishers of this journal, with a view to promote the taste for floriculture, offered to those of the wives or daughters of subscribers who would apply for them, a package of flower seeds; and we believe over 5,000 applications have been made. Hundreds of these applications are charming little essays on flowers, and would, if printed and bound

together, make an interesting volume—one that would show that the wives and daughters of American farmers are behind none others in their appreciation of the beautiful in nature, and moreover possess a degree of intelligence surpassing that of the same class in any other country. These letters have surprized us, and give us great hopes for the future of American horticulture.

FRUIT CULTURE IN INDIANA.

WE take the following pomological items from a friendly and familiar letter received from a correspondent at Versailles, Indiana. The experience of observing, practical men, gleaned in this way, is valuable; and we beg our friends in other quarters, who desire to promote the interests of pomology, to favor us in the same way. We omit the name of our correspondent, as the letter appears not to be intended for the public.

I have been trying for some years to establish an orchard of first rate fruit, but find it a more difficult task than I had expected. I consulted the works of KENRICK and DOWNING, and have been much disappointed in many of the varieties recommended by them. For example: *Prince's Harvest* is a good apple, but so unproductive as to render the trees mere cumberers of the ground. *Red Astrachan* has nothing to recommend it but good looks. The same may be said of the *Summer Queen*. *Summer Pearmain* of Cox is a good apple, but with me as yet has proved a shy bearer. *Porter* is a good bearer on young trees, but has too much acid. We have an apple here ripening at the same time with the *Porter*, which is far better; we call it the *Wine* apple. It is red, and first rate in every way. Does your *Pomme Royal*, or *Dyer*, ripen in advance of the *Porter*? (1) If it does, I would like to get some grafts. The best early apple which I have tested, is the *Carolina June*. (2) I have not seen it noticed in the eastern catalogues, nor do I think it has ever been exhibited at Cincinnati. It is a red apple, conical in form, very handsome, a great and constant bearer, and comes into bearing very early. It ripens nearly at the same time as *Prince's Harvest*. I sent some grafts of this to yourself and partner, by mail, a few winters since, and hope you will soon test its merits in your locality. I believe you were from home at the time.

I have tested many varieties of winter apples, and find but few which I consider first rate. These are—*Golden Russet*, *Prior's Red*, *White Bellflower*, *Newtown Pippin*, and *Rawles Janet*, or *Genneting*. I am planting *Norton's Melon* and *Northern Spy*, but have never seen the fruit of either variety. I hope to prove the *Spy* in a year or two.

The best pears which I have tested are *Julienne*, *Dearborn's Seedling*, *Bartlett*, *Seckel*, *Washington*, and *White Doyenne*. This last is the best of all. I have never seen what I would call a good winter pear. The *Passe Colmar* is the best; but it has a great fault—namely, dropping most of its fruit before gathering time. Have you ever seen the *Lawrence*; and if so, what do you think of it?

My orchard stands on high ground; surface rolling; subsoil stiff yellow clay, retentive of moisture, and based on blue limestone. Will such a state of things suit the *Northern Spy*? (3) It does not suit the *Baldwin*; it takes dry rot in specks; but I have raised it sound and fine, after manuring with lime and ashes.

(1) It begins to ripen earlier, but continues nearly as long in use.

(2) We have seen specimens of this variety grown at Kalamazoo, Mich., and believe it valuable, especially for the west. It resembles the *Summer Queen*—a little more conical, and deeper red.

(3) We cannot answer this, as we do not remember to have seen it grown on such soil.

HORTICULTURAL SOCIETY OF PITTSBURG.—The following gentlemen are elected officers of this Society for the ensuing year: JOHN CHISLETT, President; JOHN MURDOCK, JR., Vice President; A. HERSFERGER, Treasurer; HENRY WOODS, Secretary; A. CAMPBELL, A. B. MCQUEWAN, JAMES WINDROP, JOHN LOWEN, C. L. GOEHRING, CHAS. LOCKHART, T. J. BIGHAM, JAMES MURDOCK, JAMES MCKAIN, W. H. WILLIAMS, W. P. MARSHALL, and S. N. WICKERSHAM, Executive Committee.

HORTICULTURAL SOCIETY OF THE VALLEY OF THE GENESEE.—The officers of this Society for the present year are as follows: P. BARRY, of Rochester, President. MATHEW G. WARNER, of Rochester; JOHN J. THOMAS, of MACEDON; HENRY P. NORTON, of Brockport; R. G. PARDEE, of Palmyra; and JOHN DONNELLAN, of Greece; Vice Presidents. LEANDER WETHERELL, of Rochester, Corresponding Secretary. JOSEPH A. EASTMAN, of Rochester, Recording Secretary. JAMES H. WATTS, of Rochester, Treasurer.

GRAPE VINE MALADY.

BY W. B. LE COUTEULX, OF BLACK ROCK, N. Y.

THE disease described in the following Report, which I translate, has made its appearance upon my imported vines this year for the first time, particularly upon the *Chasselas*; but my *Isabella* vines have also suffered more or less from the effects of it. All my vines are planted in espaliers, and not in a hot-house, all to the south or east; and these last suffered less than the first. All the new limbs have black spots, and no doubt will have to be cut.

"REPORT MADE TO THE CENTRAL AGRICULTURAL SOCIETY OF PARIS, FRANCE, UPON THE MALADY WHICH NOW EXISTS UPON GRAPE VINES.—This malady upon the grape vine appeared for the first time in England in 1845. It was well observed and described by a gardener from Margate, Mr. TUCKER. But in England, as in all countries which are cold and foggy, the vine being cultivated only in hot-houses, heated by steam, can produce but a forced grape of inferior quality; still much valued by their inhabitants, unable to procure any other. One was apt to think that this disease having taken place on vines so kept in hot-houses, was but an accident from vegetation and the result of an irregular culture under exceptional conditions; but it is not so; for from the hot-house it spread to the garden, and from the garden to the fields.

"This disease made its first appearance in the neighborhood of Paris in 1849. It was first remarked on the vines planted in espaliers, from which it was not long in spreading to all the surrounding country.

"In the origin the disease offered nothing alarming; but in the following year it acquired a certain gravity, acting severely upon the vines of the Luxembourg and those of Versailles. I had an opportunity to watch its progress upon a vine in espalier, planted toward the south, in one of the gardens of the Hotel of the Invalids in Paris. But this year (1851) creates more uneasiness, as the circle of action of that dreadful scourge is enlarging considerably; from which it follows that all that zone comprising the east and the west of Paris is invaded by it, and that it seems now to take its course toward the south.

"From all reports received upon the nature of that disease, and which have been read to the Society in former meetings, it results that at Alfort and at Charenton the vines have sadly suffered from the effects of it; so much so, that even the branches have been injured, and it is feared they will have to be cut near the ground. The news from Grenoble informs us that the disease made its appearance at La Tronche, and that it is not without some importance. Other information from Fontainebleau says that the *Chasselas* is invaded by the same malady, and that great fears are entertained for the crop.

"This new disease has been named *Todium Tuckeri*, from Mr. TUCKER, who was the first person that discovered and described it. In the vineyards around Paris it is known under the name of *White disease*, on account of its showing itself by a light white dust covering the leaves; and which, almost imperceptible at first, increases so rapidly that it can soon be seen with the naked eye. On touching it, it resists like a moss whose roots should be implanted in the parenchyma of the leaves. On smelling it, it emits a strong smell of mushrooms. Seen with a magnifying glass, its aspect is that of a new rising moss, which seems to be incrustated in the follicles of the tissues, aspiring from it all the nourishing sugar. So deprived of its sap, the leaf curls up, dries, and drops. But that white dust, which is no other thing than a mushroom, goes from the leaf to the young sprouts, which it dries up, and then goes through the central line to the grape, filling all the interstices between the grains, shining on all sides upon the pedicles, enveloping the grain and impregnating it with its innumerable microscopic radicles.

"When this malady makes its invasion before the blooming of the grape, the grains hardly formed wither and dry up. Contrarily, when it appears after the blooming, the grains, suddenly deprived of their sap, take a tarnished color, crack, and show the seeds in the interior, dying before maturity. But when it happens (and it has been until now the greatest number of cases) that the grains reach safely one half of their growth, they generally complete their maturity; and one may then depend on gathering half a crop, but of spotted, bitter, and even unwholesome grapes.

"Many proceedings have been employed by the gardeners around Paris, to attenuate the evil. They have tried to take off the white substance—that is to say, the mushroom—from the leaves by brushing; but besides its being impracticable upon a large scale, it could not remove from the leaves the parasite which had invaded them. They have also tried to wash it off with pure water; then with an addition of lime or alum; but it proved ineffectual.

"At the Agronomique Institute of Versailles, powdered sulphur was added to water and thrown on the vines with the gardener's pump; the grapes have been washed with pure water, and then sulphur in powder blown upon them with a bellows; but all without success.

"New experiments are now tried in all parts of France where the vine is cultivated; and it is to be hoped that a successful remedy will be found to put a stop to this dreadful disease."

Ladies' Department.

PHLOX DRUMMONDI.

THE *Phlox Drummondii* is one of the most beautiful annual flowers; and, indeed, we are not certain but we should be justified in calling it the *finest* of all. It is remarkable for the splendor and variety of its colors. Flowers from the same seed will be found of almost every shade of color, from the deepest and most brilliant rose color, to the palest and most delicate pink. Every flower, though of the deepest carmine, has the under side of its petals of a pale blush color; and every petal, though of the palest pink, has a dark carmine spot at its base. Thus the variety of colors displayed in a bed of these flowers, almost exceeds description; and when they are seen under a bright sun, and agitated by a gentle breeze, the effect is exceedingly brilliant—we know of nothing more beautiful.

So well are we pleased with this flower, that we have sent a paper of this seed with every package; and if our lady readers should only succeed in raising a bed of this beautiful flower, we know they will feel well repaid for all their labor.

This Phlox was discovered in Texas, in 1835, by DRUMMOND, a botanical collector sent out by the Glasgow Botanical Society, who soon after died in Cuba, in the midst of his researches. This being one of the last plants discovered by Mr. DRUMMOND, it was named *Phlox Drummondii*, in honor of its lamented discoverer.

The seed should be sown in a nicely prepared bed about the first of May, lightly covered; and in July they will be in full blossom. They are very easily cultivated, requiring no other care than keeping them clear of weeds, and the ground mellow.

Our orders for flower seeds are now all supplied, amounting to over 5000 packages, each package containing 14 varieties. If from any cause applicants have not received seeds, we shall be pleased to be informed of the fact.



PHLOX DRUMMONDI.

Editor's Table.

WE are indebted to Lieut. TERRET, of the U. S. Navy, for several varieties of flower seeds from Palestine, which we shall endeavor to propagate. Mr. T. will accept our thanks.

MEXICAN POTATOES.—MESSRS. RAPALJE & Co. presented us with a peck of *Mexican Potatoes*, which we have no hesitation in saying is the dryest and best flavored potato we have eaten for many a day.

ADVERTISEMENTS, to secure insertion in the Farmer, must be received as early as the 10th of the previous month, and be of such a character as to be of interest to farmers. We publish no other. Terms—\$2.00 for every hundred words, each insertion, *paid in advance*.

Inquiries and Answers.

(W. D. O., Port Byron.) We would recommend Johnston's Catechism of Agricultural Chemistry and Geology, Norton's Elements of Scientific Agriculture, Johnston's Agricultural Chemistry, Boussingault's Rural Economy, and Liebig's Agricultural Chemistry. If these works are carefully studied in the order named, an amount of chemical knowledge will be obtained that cannot fail to be of great benefit to you, and every tiller of the soil.

(N. D. OVIATT, Copley, Ohio.) We think lime would not so increase the growth of the clover as to produce a full crop from half the proper number of plants. We have never seen much good result from a top-dressing of lime on clover, but a bushel of plaster to the acre has a decidedly beneficial effect. Clover rarely takes well when sown with oats.

Indian corn sown thick for fodder, cut early, and well cured, *may be cheaper*, as food for stock, than to "be at the expense and trouble of raising roots;" but it is much more exhausting to the soil, though probably not so much so as if allowed to mature its seed; and as the whole of it is consumed on the farm, and may be returned to the field in the form of manure, there is necessarily but little loss of the mineral constituents of the soil. *But there is probably a loss of nitrogen*; while in growing roots, clover, peas, &c., there is an *increase of nitrogen*, which is the most valuable element in all manuring substances.

From the heating nature of oilcake, it is not advisable to feed it constantly to horses, though a feed once or twice a week is good. For sheep

and cattle, it is the most valuable and nutritious food of all vegetable substances.

We shall be glad to have the results of your experiments.

The address of the owners of the Long Woolled Sheep, given in the February number, is J. McDONALD, Warren, Herkimer Co., N. Y.; and WM. RATHBONE, Springfield, Otsego Co., N. Y.

PLASTER ON CORN.—I wish some information on the subject of using plaster for corn—when and how it should be applied, &c. P. M.—*Hartsville, Ind.*

Sow a small handful on the hill just as the corn is through the soil. Its effect is very beneficial here.

CORN FOR FODDER.—Will you inform me the best method of preparing sod ground for corn for fodder, the amount of seed per acre, and what is a good crop. A SUBSCRIBER.—*Barnesville, Ohio.*

Prepare the soil as you would for planting corn in the ordinary way. The richer and mellowier it is, the better. Three and a half to four bushels of seed are usually sown *broadcast* per acre; but if sown in drills, and hoed, it does best, and the land is much cleaner for the following wheat crop. About the middle of May is the usual time of sowing. If sown broadcast, the seed should be soaked for a few hours; it is then soon up, and gets the start of the weeds. It is an admirable green food for working oxen or milch cows in summer, and is very profitably grown for this purpose. If intended for fodder, it should be cut and cured before frost touches it. Six tons of dry fodder per acre is a good crop, though much larger have been obtained.

WOOLEN RAGS AS A MANURE.—After a careful perusal of your paper for two years past, I do not remember seeing any reference made to woolen rags as a manure. I am near a paper mill, and have about half an acre of land that I intend planting wholly with potatoes and carrots. I am desirous of knowing the best mode of employing woolen rags, intending to use about a ton of them on the half acre. Please give your ideas on the subject, and I will give you the result of my operations, when ascertained. J. C.—*Toronto, C. W.*

Woolen rags contain 17 per cent. of nitrogen, and are consequently a highly valuable manure for corn, wheat, and potatoes. They are extensively used in England as a manure for wheat, especially on heavy lands, and sell for \$25 per ton. They are usually plowed under, at the rate of 500 pounds per acre. The more finely they are reduced, the better; and if they were soaked in water or barn-yard wash for some time previous to their application, they would decompose more speedily, and consequently be more efficacious for

the first crop. If they are pure woolen rags, "one ton to half an acre" would be much too high a manuring; and if the rags all decompose the first year, would be very injurious. It is a first rate guano that contains 15 per cent. of nitrogen, whereas woolen rags contain 17 per cent.; and 400 lbs. of guano per acre is a good dressing for wheat or potatoes. 700 lbs. per acre often proves very injurious to the crop.

Ordinary barn-yard manure contains about half a per cent. of nitrogen; so that one ton of woolen rags would, in this respect, be equal to 34 tons of manure. Horn shavings, leather, hair, and dried blood, have the same composition as woolen rags, and are equally valuable. Blood, however, is considered the best by farmers, because it acts quicker; but the ultimate result must be the same.

Woolen rags are found very valuable for *hops*. Plowed in near their roots, their effect is very lasting and beneficial. Previous to the potato disease, we have seen 600 bushels of potatoes obtained from an acre on which a compost of horse manure and pieces of leather that had been decomposing for six or eight months was used at the rate of 15 tons per acre.

Were we going to use woolen rags for potatoes, we should soak them, and apply in the hill at the rate of 700 or 800 lbs. per acre.

Please let us know the result of the application.

HORTICULTURAL

(Ancaster, C. W.) HEDGE PLANTS.—The White Thorn is affected with mildew, leaf-blight, wooly aphid, &c., whilst the Buckthorn is exempt from all. On this account it is preferable for this country. The Honey Locust is a rapid growing plant, with powerful, sharp spines, and with proper attention to shearing, to make it dense at the bottom, makes a good hedge.

(A. G. H., Byron, Mich.) APPLE SEEDS.—They cannot be procured here, now. The other articles sent alone, would not be worth cost of carriage.

(A. W. P., Columbus, Iowa.) PLANTING APPLE GRAFTS ON SOD LAND.—It should be submitted to a summer fallow the season before planting. Set in rows three and a half feet apart, if you intend to cultivate with a horse, and the plants a foot or fifteen inches apart in the rows.

GRIDLED TREES.—Mr. JAS. HARRIS, of Schodack, N. Y., in reply to inquiries in our last number, says that he has saved girdled trees in the following manner:—

"Take scions of last years' growth, cut the right length, flatten both ends, then with a narrow knife run under the bark above and be-

low the girdled part, and insert the scions. Three or four may be inserted, or two inches apart, and if near the ground, bank up with earth; if too high for this, put on some mud and tie straw over it."

Mr. H. STANFORD, of Sugar Grove, Pa., writes us of the same remedy; but he fits his scions to the tree on the under side the whole length, fastens them in with small tacks, and fills the cavities with wax.

Mr. ORRIN WICKS, of South Waterloo, N. Y., and Mr. GEO. W. SHEPPARD, of Geneva, Ashtabula Co., Ohio, write us of the same remedy.

OSAGE ORANGE HEDGES.—Mr. GEORGE W. SHEPPARD, Geneva, Ashtabula Co., Ohio, writes us:—

"I have 150 rods now two years old; the first I set nine inches apart in the single row, the remainder one foot apart. I think a foot near enough, for if cut off, as they should be, three or four years, within six, eight, ten, or twelve inches of the ground, they will be thick enough to keep out hens or pigs; and in six or eight years, high and strong enough to keep out men or oxen. I mix the seed with an equal quantity of sand moistened, keep it moist all winter, and let it freeze and thaw, and plant it when I plant corn. It is the best plant for hedge in this country, perfectly hardy here, on the south shore of Lake Erie."

CULTURE AND MANURING OF TREES.—"If farmers would hoe their trees as often as their corn, and apply ashes, leached or unleached, around them, they would not be troubled with mice; and ashes and chip manure will make them grow enough faster to pay for the trouble twice over. G. W. SHEPPARD.

Be careful not to let the *un*-leached ashes touch the bark of the tree.—Ed.

(B. S. B., Greenwood, Steuben Co.) DWARF FRUIT TREES.—We must refer you to the nursery-men's advertisements.

Dwarf Apples are budded or grafted on the Paradise stock, (a dwarf species of the apple). Set them five or six feet apart.

Dwarf Pears should be budded or grafted on the Angers or French Quince stock, and they may be set eight to twelve feet apart, according to circumstances.

Plant either in the spring or fall. We hold that, if the soil be dry and the planting properly done, both seasons are equally good for hardy trees. The "Fruit Garden" will furnish you information on these points more in detail than we possibly can now. You can buy stock at the nurseries this spring, and either root-graft them before setting out, or plant them and they will be fit for budding in August next. We advise the latter.

(W. H. R., Pultneyville, N. Y.) The Angers, or French Quince, are more vigorous than our common variety, and make a better stock for the

pear, as they keep pace better with its growth. The common quince almost ceases to grow after two years' growth of the pear on them, and then the trees die immediately. On the French stock we have trees ten years old, in which there is very little difference between the size of the pear and quince. Stocks should be, when budded, half to three-quarters of an inch in diameter.

(J. K. Cavan, C. W.) FOREIGN GRAPES IN A COLD VINERY.—You can ripen grapes perfectly in a cold vinery in your latitude— $41\frac{1}{2}$ deg. north. You will have short rafters in a house only fourteen feet wide, and, of course, shorter canes, but that is the only or principal difference. The length will determine the number of vines—one to each rafter at about three to three and a half feet apart.

Five varieties, including one native.—Native—*Catawba*. Foreign—*Black Hamburg*, *White Frontignan*, *Royal Muscadine*, *Black St. Peters*.

Instead of any two of the above, you might take the *Chusselas of Fontainebleau*, and *Muscat of Alexandria*.

GROWTH OF A PLUM GRAFT.—MR. AMOS FREEMAN, Wheatfield, N. Y., says—

"Last spring I set a graft of the *Duquesne* plum in a *Yellow Egg* stock, and in the fall the longest shoot measured 6 feet $1\frac{1}{2}$ inches in length; the next, 5 feet $6\frac{3}{4}$ inches; whole growth, 33 feet 1 inch, besides one limb taken off for buds."

INSECTS.—"My fruit trees are infested with insects that prevent their bearing. How shall I destroy them? H.—*East Hampton*."

What insects? You will find in back numbers of this journal, methods described of destroying caterpillars, slugs, aphids, &c., the common enemies of fruit trees.

OSAGE ORANGE.—Please inform me whether the Osage Orange has been cultivated long for hedging purposes, in your section of country; and if so, whether the growth still continues as luxuriant as during the first two or three years. I should also be pleased to know whether it is subject to sprout from the root, and spread, to the annoyance of the farmer. It has but lately been introduced into this section of country; and from its unusual growth, I have been disposed to question the propriety of cultivating it, lest it can not be kept within bounds.

Necessity will soon compel many of us to resort to *hedging*, in consequence of the scarcity of rail timber in this section of country; and we feel desirous of gaining some information in another way than that of sad experience. JOHN P. BRADY.—*Cedar Grove, Ind.*

The vigor remarkable in young plants, subsides in two or three years, when it has been shorn a few times. We have never seen it throw up suckers. It is just beginning to be cultivated here. There are some good specimens of hedge of three years' growth, and it may be some older. If it comes well through the present severe winter, its hardness will be less a matter of doubt than at present.

Bone Dust.

BONE DUST, Coarse Turnings and Sawings, when taken in equal parts, price \$2.25 per bbl., including package.—This article is fresh, and warranted pure, from the Empire Mills.

[4-21] LONGETT & GRIFFING,
25 Cliff Street, New York.

Manures.

PERUVIAN GUANO, Bone Dust, Pulverized Charcoal, Poudrette, Plaster, Wood's Renovating Salts, Potash, Sulphuric Acid, Sugar-house Scum, for sale in lots to suit purchasers.

[4-21] LONGETT & GRIFFING,
25 Cliff Street, New York.

THE subscriber deals in, and sells on commission, all kinds of good patents. Worthless ones need not be offered. A good Grass Mower wanted.

The best of reference given. ALLEN VANE,
No. 157 South Water Street, Chicago, Ill.
April 10, 1852.—5-21.

Osage Orange for Hedges.

WE can furnish any number of fine yearling plants at \$1.50 per 100, or \$10 per 1000, or at \$5 where 3000 or more are taken. Orders should be sent early. It takes about 32 plants to the rod, planted either in single rows at six inches apart, or in double rows a foot apart—either of which makes a good hedge.

ELLWANGER & BARRY,
Rochester, N. Y., Jan., 1852.

Just Published.

THORBURN'S Annual Descriptive Catalogue of Flower Seeds, for 1852, with Practical Directions for their Culture and Treatment, will be forwarded free of charge to post-paid applicants enclosing a Postoffice stamp.

[5-11] J. M. THORBURN & CO.,
Seedsmen, Florists, &c.,
No. 15 John Street, New York.

Osage Orange Seed.

THE subscribers have just received from careful collectors in Texas, a lot of fresh Osage Orange Seed of very superior quality. Price, 75 cts. per quart, or \$20 per bushel.

Also, clean Buckhorn Seed at \$2 per lb.; and small quantities of Norway Spruce, Weymouth Pine, Scotch Fir, European Silver Fir, Chinese Arbor Vite, &c., &c.

[5-11] J. M. THORBURN & CO.,
Seedsmen, Florists, &c.,
No. 15 John Street, New York.

Potatoes for Seed.

1000 bushels *White Mexican Potatoes*, an excellent potato, yielding first rate and never rotting. It is the favorite here. Price, \$4 per barrel.

Also, 100 bushels of the *Mexican Potato*—the very best potato in existence for the table, so pronounced by all who have tested them.

Those who wish either of these kinds must apply soon, as they are going off with a rush.
Rochester, N. Y., May, 1852. J. RAPALJE & CO.

Spring Wheat.

WE have just received by the first Boat from Canada—100 bu. of the celebrated Fife Wheat, which does not rust.

100 bu. Club Wheat.
100 " Black Sen do, grown in this State.
100 " Italian Wheat.
25 " Spring Rye.

Farmers who are in want of a good article, will please give us a call, and get some of the right kind of seed, at the Genesee Seed Store, 63 and 65 Buffalo st., Rochester, N. Y. April, 1852. J. RAPALJE & CO.

Rochester Commercial Nurseries.

BISSELL & HOOKER offer for sale, in large or small quantities, a large stock of Fruit Trees, which they believe are inferior to none in health, beauty, or accuracy—among which are Apple, Pear, Peach, and Cherry Standards; Dwarf Pears on imported Quince stocks; Grape Vines, native and foreign; Raspberries, Strawberries, Currants, Gooseberries—strong, imported plants, at low rates. Osage Orange hedge plants. Ornamental Trees, Evergreens, Roses, &c. Green-house and Bedding-out Plants, of superior quality. Double Dahlias, Calceolarias, &c.—all of which we are confident will give satisfaction.

A general Catalogue will be sent gratis to all post-paid applicants. [5-21]

Fruit Trees.

I AGAIN offer a large stock of Trees—about 100,000—of fine thrifty growth, composed in part of Apple, Pear, Peach, Cherry, &c.; together with an assortment of Green-House Plants suitable for bedding out—all of which are offered at extremely low prices.

Wholesale prices of Apple Trees will be from \$9 to \$10 per 100.

I would recommend to buyers, after examining other nurseries, to inspect mine before purchasing.

CHARLES POWIS,

Greene, Ridge Plank Road, N. Y., March 1, 1852.—3-31.

Fruit and Ornamental Trees.

ELLWANGER & BARRY beg to remind those who intend to plant next spring, that their stock of Standard Fruit Trees for orchards, Dwarf Fruit Trees for gardens, Ornamental Trees for streets, parks, gardens, and pleasure grounds, shrubs, Roses, &c., is very large, and offers great inducements to those who desire first rate articles.

A complete Descriptive Catalogue is sent gratis to all who apply post-paid and send stamps for postage, which must now be pre-paid—5 cts. for 500 miles or under; 10 cts. over 500 miles and below 1000. A Wholesale Catalogue also furnished.

See advertisement of Shrubs, &c., &c.

Mount Hope Nurseries, Rochester, N. Y., March 1, 1852.

Morgan Stock for Sale.

THE subscriber having inducements offered him to change his residence, offers for sale, at auction, on the 18th day of August next, at 10 o'clock, at Scottsville, his entire *Morgan Stock*, consisting of a very fast traveling mare, valuable for breeding, in foal by the celebrated Vermont Morgan horse *General Gifford*, imported from Vermont in 1846, pronounced by competent judges to be the best specimen of his race, and awarded the first premium on Morgan horses at the State Fair in 1851. Also, *Zachary Taylor*, two years old in June; and *Gifford Morgan*, four years old in August; both bay studs by above horse and mare, suitable for matching or stock. Gifford Morgan has a surprisingly beautiful coat, unvaryingly dappled. Credit one year on interest. Until the 1st of July next, Gifford Morgan will be kept by some suitable person at or near Scottsville, for improvement of stock, at \$10 to insure. J. DORR.

Scottsville, N. Y., May, 1852.—5-11.

Rochester Seed Store and Ag. Warehouse,

No. 29 BUFFALO STREET, ROCHESTER, N. Y.

Sign of "The Plow," opposite the Arcade.

THE subscriber offers to farmers the largest and most complete assortment of *Implements and seeds* in Western New York, consisting of Improved Eagle, Peckskill, and Iron beam Plows; Cultivators, Straw Cutters, Corn Shellers, Ox Yokes and Bows, Road Scrapers, Shovels, Spades, Hoes, Rakes, &c., &c. Also, Railroad Horse Powers & Threshers.

His stock of *Fruit Seeds* is large, and warranted to be of the purest description. Carrot, Sugar Beet, Mangel Wurzel, Ruta Baga, Flat Turnip, and other seeds, by the pound, were either grown by him or imported from London, and can be relied upon as *good seeds*, and true to their kinds. Farmers and others are invited to call and examine the above stock. Descriptive Catalogues of Seeds, &c., may be had on application, or sent by mail.

May, 1852.

J. P. FOGG.

The Celebrated Horse "Morgan Eagle."

THIS truly celebrated horse will stand for Mares this season, commencing April 19th, at the Franklin House in Genesee, on Monday, Tuesday, Wednesday, and Thursday, and at Seville's Eagle Hotel in Mt. Morris, on Friday and Saturday of each week during the season.

"Morgan Eagle" was purchased in the fall of 1847, in Tunbridge, Vt., by J. Henderson, at a high price, for the express purpose of improving the stock of horses in this county. He is about 16 hands high, and well proportioned, is a bright bay, and for symmetry and action, cannot be surpassed. Morgan Eagle, and the celebrated trotting mare, Lady Sutton, of New York, were sired by Old Morgan Eagle, of Vermont.

Breeders of horses are particularly requested to call and examine him.

Pasture will be furnished for mares sent from a distance and good attention paid to them. Escapes at the risk of the owners. Those who part with mares before foaling, will be held responsible for the insurance. Mares must be returned every two weeks or they will be held for the insurance. J. HENDERSON & Z. H. AUSTIN,

Genesee, April 16, 1852.

NEW AND FINE SHRUBS AND PLANTS.

ELLWANGER & BARRY, Proprietors of the Mount Hope Nurseries, Rochester, N. Y., solicit the attention of those interested in Ornamental Plants to their large stock of rare and beautiful Shrubs and Plants, among which are the following:

HARDY SHRUBS.

Deutzia Scabra, or Garland Deutzia, a fine white flowering shrub.

Forsythia Viridissima.

Ribes Gordoni—Gordon's Currant—yellow and crimson, very fine.

Spiraea Prænitifolia flore pleno—small, double, white flowers in great profusion; fine dense habit.

Spiraea lanceolata, or Reevesi, one of the finest of the genus.

Spiræa Chamædrifolia, *Nicoverti*, *Lindleyana*, *Japonica*, and twenty others.

Syringa (Philadelphia) *pubescens*, *Zepherii*, *Cordata*, *Double*, *Calumbiana*, and others, all fine.

Lonicera Lillothorpi—a fine Californian shrub.

Tamarix, *Africana*, *germanica*, *Golfetti*, and *Lebanotica*.

Viburnum Lantanoides, a beautiful shrub.

Vibula Rosa—the finest hardy shrub, lately introduced from China.

The above excellent things can be furnished in quantities, at low prices.

SELECT GREEN-HOUSE AND BEDDING PLANTS.

FRONTSIAS.—Our collection is one of the best in America. The most distinct and best varieties yet introduced and quite rare, such as *Pearl of England*, *Fair Rosamond*, *Serratifolia*, *Serratifolia multiflora*, *Fulgens Corymbiflora*, *Corymbiflora Alba*, *Magnificent*, *President*, *President Porcher*, *Spectabilis*, &c., are propagated largely.

VERBENAS.—A collection of fifty varieties, comprising everything fine introduced to this time.

HELIOTOPES.—*Souvenir de Liege*, *Corymbosum*, and some new varieties just received and to be announced hereafter.

PLUMBAGO LARVENTÆ.

CUPHEAS.—*Platycentra*, *Stringulosa*, and others. The first is one of the finest bedding plants.

LANTANAS.—*Eringi*, the fine new Cincinnati variety, rose and straw color; *Mutabilis Major*, and several others.

BOUYARDIAS.—*Triphylla*, and others.

ABUTILONS.

SALVIAS.—*Splendens Major*, *Oppositifolia*, *Azurea*, and others—superb plants for masses.

FABIANA IMBRICATA.

HYDRANGÆAS.—*Hortensis*, *Japonica*, *Cordata*, &c.

BUTTDLEA LINDBLEYANA.—A fine shrubby plant with large clusters of purplish lilac flowers; blooms in the autumn.

HABROTHIAMUS ELEGANS.—A superb plant, half shrubby, with large clusters of showy crimson flowers; blooms equally well in the open ground in autumn, and in the house in winter.

PETUNIAS.—A large collection, embracing all distinct and good sorts.

LOBELIA FULGENS INSIGNIS. **LOBELIA FULGENS ALEA.**—flowers of dazzling beauty—both new.

VERONICA LINDBLEYANA.—A charming autumn flowering plant; long elegant spikes of pale (nearly white) blossoms. *Veronica Androscent*—finest of all—new.

TREE VIOLETS.—white and purple.

CHRYSASTEMUMS.—A fine collection of the novel and beautiful pom-pom or dwarf varieties.

DAHLIAS.—A superb collection, including the English and French prize sorts of 1851—all at very low rates.

CINERARIAS.—A fine collection of new and beautiful sorts, including *Magnificent*, *Abilla*, *David Copperfield*, *Wilmington*, *Beauty of Newington*, &c. &c.

All the above articles furnished in large or small quantities, at low rates, and packed so as to go any distance with safety.

Priced Catalogues of Dahlias, &c. &c., ready 1st of March. March 1, 1852.

Albany Tile Works,

No. 60 Lancaster St., West of Medical College.

THE subscriber has now on hand, and is prepared to furnish to Agriculturists, Horse-Shoe and Sole Tile, for land drainage, of the most approved patterns. They are over 1 foot in length, 2 3/4 to 4 1/2 inches calibre, from \$12 to \$18 per 1000 pieces—being the cheapest and most durable article. Orders from a distance will receive prompt attention. [4-9] JOHN GOTT, JR.

EMERY & CO.'S**Overshot Threshing Machine, with Vibrating and revolving Separators.**

THE above Threshers have been extensively manufactured and sold by us for the past six years, and with a steadily increasing demand. During the two years last past, and with our latest Improved Railroad Powers, their sale has more than doubled over the same length of time before.

Although over two thousand of these Threshers have been sold by us up to this time, and without exception have given the fullest satisfaction as heretofore made, we can safely say they are, as now made, worth at least 50 per cent. more than heretofore, and without any increase in prices being charged for them.

Their construction is such that the grain and straw are carried by the cylinder from a level feeding-table, over and between it and the concave, which is placed above instead of below as is generally done in others. The cylinders being 26 to 30 inches long, and 14 inches diameter, are much longer but smaller than those generally in use—giving more room for feeding, in proportion to work done, and doing it nearer the center of motion, and working easier, as the smaller the diameter the greater the power. Again, we require but about half the number of spikes in the cylinder, and an increased motion, so that the spikes may pass through with a velocity sufficient to take off all the grain.

The concaves have an increased number of spikes, which for both cylinder and concave are swedged into uniform shape and size, from the best Swedes Iron. They are set with an inclination which admits the straw and grain to pass freely, and with as little breaking of the straw as is consistent with a perfect separation of the grain—thus producing a sort of stripping or carding process. The concave is so confined as to be readily adjusted and present any desired angle of the spikes to the grain, and also increase or decrease the capacity of the throat, thereby retaining the straw a longer or shorter space of time in passing, as the condition and kinds of grain may require. By this arrangement, there is a saving of power of from 30 to 50 per cent. over the ordinary Threshers, whose spikes pass each other at right angles, which operation necessarily breaks the straw into many pieces at the expense of much power—a process much more easily done with a good hay cutter with sharp knives, than with the rounded edges which well formed spikes present to the straw. The feeding-table is level, allowing the feeder to stand upright and be little annoyed by dust, dirt, &c. The overshot motion avoids accidents to men or machine, (by preventing any stones, sticks, &c., getting into it in feeding,) which frequently occur with the inclined feeding-board. The grain by this motion is elevated sufficiently to be thrown upon a large sieve or separator, where it is separated from the straw and falls through upon the ground or floor, together with the fine chaff, dust, &c., while the straw is discharged at the end of the separator, ready for stacking or binding.

The shafts of our cylinders are made of solid cast steel, manufactured and imported for us expressly for the purpose; and all the boxes or bearings are made of or lined with Babbet metal. The boxes used by us are always of two parts, in order to be adjusted as they may wear, or to vary the position of the cylinder, as well as to allow them to be removed, if necessary for cleaning or repair, without removing the pulleys or other parts of the machine. This is an important advantage over those boxes which are made of a sort of tube, and only removed by first removing the pulleys, &c., &c., and are never adjustable to accommodate themselves to any wearing.

The pulleys are polished and fitted to both ends of the shaft and confined by nuts and screws, and with our India rubber band, which we invariably use, form a perfectly air-tight connection; thereby bringing the atmospheric pressure to our aid, and preventing any slipping of the band. A band of this kind, say 30 feet long 3½ inches wide, will drive equally strong when four inches looser than if made of leather. This kind of band requires little care, compared with leather, is equally pliable in all temperatures, and is not affected by dryness or wet, grease, acid, or dust. It is made with but one joint, and that smoothly cemented and copper riveted, and is equally durable for straight bands as leather, the difference in cost being a little in favor of India rubber. The chief advantage of using these bands, is causing less stress upon the shafts, allowing them to run with less friction and wear on both shafts and boxes.

Cleaner and Thresher, Combined.

During the past three years we have spared neither time nor money in endeavoring to produce, at one and the same time, a CLEANING THRESHER, which will perform as well and rapidly as our Thresher and Separator, with the

same force of men and team to operate it, while the increased cost of such combination should not exceed the value of a good fanning mill, say \$25 to \$30. During the past two seasons we have succeeded to our entire satisfaction in all respects excepting cost of construction, the increased expense of manufacturing being some fifty to seventy-five dollars, and bringing the price fully up to that of Pitts' celebrated Patent Thresher and Cleaner, which has been extensively and favorably known throughout the whole country for the past fifteen years; and when adapted for two horses, well made, and driven by our two-horse power, will do as well as any now in use, our own not excepted, setting aside perhaps something in quantity of work done.

The great excess of the demand being for our Threshers and Separators instead of Cleaners, we are compelled to confine ourselves and facilities chiefly to the former, making Cleaners only to order, and at the price of one hundred dollars each, instead of seventy-five, as heretofore advertised by us.

From our own observations, and the slow adoption of the Cleaner combined, when used by farmers with barns, and for their own purposes, we would not recommend them on the ground of economy, as the grain can generally be threshed better and faster with the Separator; and the simplicity of the one as compared with the other, together with the difference of skill required in those attending both kinds, is vastly in favor of the Thresher and Separator. Those farmers using their straw for feeding, or selling in market, find it much more valuable when threshed with a Separator. It is entirely free from the dust, dirt, and fine chaff which is mixed thoroughly through the whole mass by the current of air thrown from a Cleaner.

In field threshing, and where time is of the greatest consideration, and there is risk from exposure to weather, the straw of little value, large Cleaners, with more men and horses, are often preferable.

We have received many complimentary letters concerning our Thresher and Separator, and in every instance where both have been used, the preference for economy has been given the Thresher and Separator for farmers own use.

We can not better express the general feeling among the farmers concerning the relative advantages of Threshers and Separators, and Threshers and Cleaners, than by giving extracts from several correspondents who have seen and used both.

Extract from letter of Russel Kilbourne, of Paris Hill, Oneida Co., N. Y.

"Sirs—Since the first two hundred bushels of wheat threshed with your latest improved Railroad Horse Power and Threshing Machine and Separator, they have performed well. Two or three farmers, neighbors near me, desire machines for their own use. How soon can you ship them after they are ordered, and can you sell them any less on account of the lateness of the season? I wish very much to sell two or three of them here, if possible; not only because I think the purchasers would be better pleased with them, but because Mr. Osborn, Wheeler's agent, and who has one of Wheeler's Two-Horse Power Threshers and Winnowers here, is determined that none of yours shall be sold if he can prevent it."

In a subsequent letter, he again writes us: "The more I see of Wheeler's Power and Winnowers, the more I don't like it. They can thresh just about seventy-five bushels of first rate wheat per day."

Extract of letter from Wm. H. Chalmers, of West Galway, Saratoga Co., N. Y.

"Gentlemen—I have a small team, and with moderate elevation, and without their drawing in harness, I put through large sheaves of wheat at the rate of one hundred every ten minutes, threshing it thoroughly. Much more could be done for a short time; but I mean with the elevation and labor of team as I use in following threshing. I firmly believe your improved Power Thresher and Separator will supersede anything I have seen. Many farmers prefer the Thresher and Separator to the Winnowers, as grain can be threshed faster and better without them—requiring less men, thereby saving sufficient time for cleaning with a good Fanning Mill. I have seen one of Wheeler's Horse Powers, with Thresher and Winnowers, at work here, threshing but one quarter as fast as I do with your machines. An Eight-Horse Power, with Thresher and Cleaner, working in this vicinity, requiring twice as many men, is pronounced, by those taking away the straw from both, to thresh less per day than mine. I wish you to write me if you have made any improvements since mine, and have you Power, &c., on hand, as I expect to sell some."

Extract from letter of Peter Webber, Herkimer, Feb. 3, '52.

"Gentlemen—After giving your improved Horse Power

Thresher and Separator a thorough trial, I consider it superior to any I have seen or tried; it works to my perfect satisfaction. I had given the others a trial before ordering yours, but was dissatisfied until I saw yours operate. I feel a pleasure in recommending it to farmers in general as being well made, and as having no equal in arrangement, power, or workmanship."

Extract of letter from W. D. Mason, Jefferson, Ashtabula Co., Ohio, Nov. 30, 1851.

"Gentlemen—I write to cover your terms for your Improved Railroad Horse Power. I enclose a copy of Wheeler's, which I received from his agent; and if yours come near the same, you may consider this an order for one, for which I will remit as soon as I get your answer. I have tried Wheeler's Power, at the request of his agent, but find the friction so great upon the pinions that it causes me to think it cannot be a lasting power."

Extract from letter of J. N. Rottiers, of Lafargeville, Jefferson Co., N. Y.

"Dear Sirs—Your last set of Improved Horse Power Thresher and Separator has safely arrived, and in the best condition. The whole have given the best of satisfaction, and are the admiration of every one. The Saw Mill has not been tried, but presume will prove as good as the other labor-saving implements made at your establishment.—Wheeler, Melick, & Co., of your city, advertise a Thresher and Cleaner, and recommend it for speed and simplicity. I should like to have your opinion of its merits, knowing as I do that you are always ready to give everything its due."

For further testimonials concerning the utility and superiority of our Threshers and Separators, and also our Improved Railroad Horse Powers, we refer the public to the following persons from among the many to whom we have recently sold them, and taken in exchange the Wheeler's Powers, Threshers, &c., at a discount in favor of our own of from five to fifty dollars each; and in nearly all cases they are being used for public threshing.

Hos. J. M. SHERWOOD, Auburn, N. Y.;
JNO. McD. McINTYRE, Esq., Albany, N. Y.;
JNO. N. ROTTIERS, Esq., Lafargeville, Jeff. Co., N. Y.;
H. L. STEWARTS ROOT, Albany County;
JACOB LANSING, Greenbush, Rensselaer Co., N. Y.;
REUBEN YOUNG, Berne, Albany Co., N. Y.;
GEORGE L. HAYNES, Fultonham, Scho. Co., N. Y.;
SMITH, Canajoharie, Montgomery Co., N. Y.;
DETMER, Canajoharie, Mont. Co., N. Y.;
DIEVENDORF, Fort Plain, Mont. Co., N. Y.;
E. STILLWELL, Fort Plain, Mont. Co., N. Y.;
COOPER & WOODRUFF, Watertown, Jeff. Co., N. Y.;
J. A. DUNN, (Saratoga and Whitehall R. R.) Saratoga;
JOHN POST, Boonville, Oneida Co., N. Y.;
ELA MERRIAM, Lynden, Lewis Co., N. Y.;
J. C. COLLINS, Constableville, Lewis Co., N. Y.

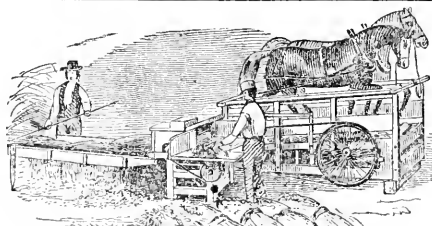

Emery & Co.'s Railroad Horse Powers & ROCHESTER AGENCY.

THE subscriber having been in the employ of Messrs. Emery & Co., of Albany, for the last six years, has been induced to open an agency for the sale of their justly celebrated Premium Horse Powers, Threshers, Separators, &c., in Rochester. Particular attention will be paid to selling and putting up the Horse Powers, and other fixtures for threshing, &c. A thorough knowledge of these machines enables him to put them up more satisfactorily than has been done heretofore. Price and terms same as at Albany, transportation added.

We will also keep for sale, Emery's Seed Planters, the best in use; Circular and Cross Cut Saw Mills, ready for use, adapted to the Power; Plows; Cultivators; Hay Cutters; and all other agricultural implements.

All interested are invited to call and examine the machines and implements at the store of Briggs & Bro., No. 63 State Street, Rochester, N. Y. E. D. HALLOCK.

McCormick's Reaping and Mowing Machine.

IN offering my Reaping and Mowing Machine to the farmers of the country for the next harvest, from the many flattering notices that have been taken of it during the past year by the press generally, it is necessary to add but little in relation to its merits at this time. In addition to the "Great Medal" awarded by the "Council of Chairmen of the Great Exhibition of all Nations," in London—the award made after two trials with Hussey's machine, (and one made with an English machine made on the plan of Hussey's)—one made in cutting heavy green wheat, and the other in cutting ripe wheat in a fair condition for harvesting—the first premiums or medals of the State Agricultural Societies of Wisconsin, Michigan, New York, and Pennsylvania, and of the Franklin Institute of Philadelphia, have been awarded for the same, during the last fall; and also the gold medal of the "Chicago Mechanics' Institute," for the "best reaping and mowing machine," after a trial by its committee in cutting prairie grass, in competition with Ruggs & Danford's. It is only necessary to add that this machine has been considerably improved during the last summer, and is now warranted to operate as well in cutting grass as grain—the additional mowing attachment, with a separate sickle, and some other extras, only costing \$30, or \$25 if paid in cash.

As a further admonition both to infringers and farmers, I have to say that while Seymour & Morgan are going on to manufacture more reapers, they have made no provision to pay the judgment against them for \$17,306; and another suit for infringement in the manufacture of five hundred reapers since the commencement of the first is about to be brought against them—and that, if they fail to pay the damages, the purchasers are not only liable, but may at any time and will be sued for the same.

These machines are not only improved in construction, but are being manufactured in a style commensurate with their extended reputation, and more expensively than ever before, being determined that that reputation shall be sustained. The price of the reaper alone, as heretofore, is \$105, in cash; or \$110, part cash and part on time, deliverable in Buffalo or Rochester. And it is warranted as usual to cut one and a half acres of grain per hour; and the mowing machine one acre per hour, and on smooth land to do the cutting as well as is done by ordinary mowing. Mowing attachments for old reapers, being more expensively constructed, will cost \$55, as heretofore.

Washington, April 10, 1852. C. H. McCORMICK.

P. S. The Reapers will be forwarded to any part of the State or the Canadas, if ordered in season of THOS. J. PATTERSON, the General Agent at Rochester, Office No. 6 Burns' Building. Responsible agents wanted by him, who will undertake to sell the machines in the unoccupied districts in New York and Canada, to whom liberal commissions will be allowed.

Peas! Peas!!

WE are now receiving by the first boat from Canada—1,000 bushels pure White Field Peas, such as Golden Vine, Creeper, White Canada, etc.

500 bushels White Marrowfat.
100 " Black Eyed do.
100 " Blue Prussian.
200 " Early Washington.
100 " Early Frame.
100 " Early Warwick.

Farmers who want good Peas at low prices, will please call at the Genesee Seed Store and Agricultural Warehouse, 63 and 65 Buffalo st. J. RAPALJE & CO. April, 1852.

Tents! Tents!!

FOR SALE, to rent, or made to order, of any required dimensions. Agricultural Societies wishing to hire Tents the coming season, will please make early application, as by knowing early how many, and at what time they will be needed, I can make arrangements to supply all.

E. C. WILLIAMS, AGENT.

Sail and Tent Maker, No. 12 Buffalo St., Rochester, N. Y. N. B.—Flags, National and Agricultural, with devices, or any other kind, made to order at short notice. April, 1852.

Union Agricultural Warehouse and Seed Store.

RALPH & CO., No. 23 Fulton Street, New York, near Fulton Market, Dealers in all the most approved Agricultural and Horticultural Implements; Imported and American Field and Garden Seeds; Ornamental Shade and Fruit Trees; Guano; Bone Dust; Poudreite, &c. Wrought Iron Plows, Trucks, Barrows, &c., &c., always on hand. Also, the Excelsior, or California Plow. [3-3]

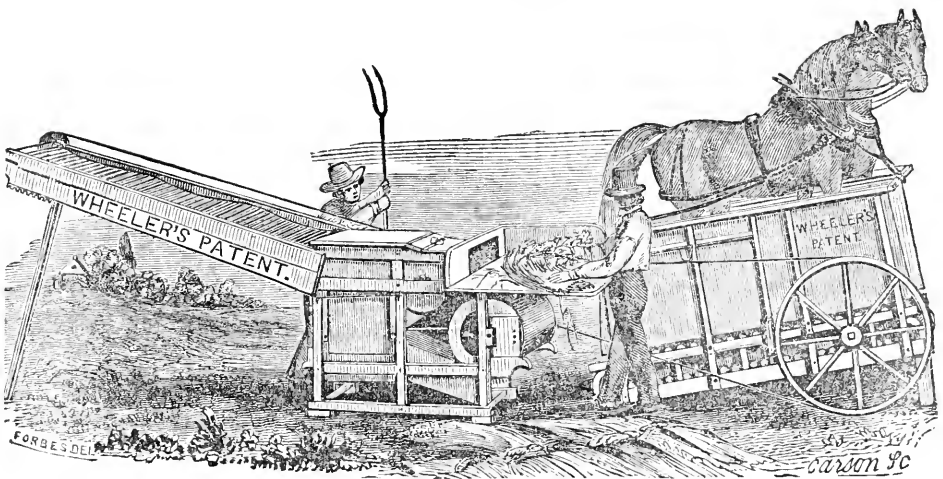

New York State Agricultural Works, ALBANY, N. Y.,

BY WHEELER, MELICK & CO.

THE subscribers offer this season a new and most valuable machine in the successful combination of a *Winnower* with their *Overshot Thresher*. It is easily driven by one *Double Horse Power*, and has now been fairly tested, a large number having been in constant use during the past threshing season.

We have numerous letters from gentlemen who have used the *Winnower*, and gave extracts from a few of them in our advertisements of last month, and we now insert a few more. We might add a large number, but it is deemed unnecessary.

[From R. Olney, of Portage, N. Y.]

Messrs. WHEELER, MELICK, & Co.—I will now state some facts in regard to your *Thresher* and *Winnower*. We first used it to thresh oats, which were good and not very long straw. With five hands we threshed and cleaned fit for any market, 60 bushels per hour while running. This is not guess work, as is frequently the case, but we kept the time to the minutes, and much larger figures might have been made had we exerted ourselves. Our wheat was *heavy growth and very long straw*. We averaged 20 to 25 bushels an hour, using a pair of mules and a span of very light horses alternately; but with either team alone, and five hands, I can thresh 400 bushels good oats a day, and half that quantity of wheat, and make it no harder for team or hands than ordinary farm work. The machine is admirably adapted to the farmer's use; can be worked at so little expense and in bad weather when little else can be done. It is of the most simple and durable construction, there being nothing liable to break or soon wear out but that a common farmer can repair. It cleans the grain well and wastes less than any other I ever examined. I write this minutely that you may understand the facts as they are; the figures I have given being taken from our ordinary threshing without any effort to hurry business.

[From S. H. Olney, of Granger, N. Y.]

Messrs. WHEELER, MELICK, & Co.—I have used your *Patent Horse Power* and *Winnower* while it threshed about 3000 bushels of grain, and am happy to say it has given the best satisfaction. With a light pair of horses and five hands we have threshed from 50 to 60 bushels of oats per hour, and about half as much wheat. My ordinary day's work of oats is from 250 to 300 bushels and 125 to 150 of wheat. I can confidently recommend this machine to farmers as superior to any I have used, although I have used various kinds for about 15 years.

[From Chester Olney, Dated March 1, 1852.]

Messrs. WHEELER, MELICK, & Co.—Last fall I employed Mr. Olney with one of your *Powers* & *Winnowers* to do my threshing, and I most cheerfully state that the work was done better, with a less number of hands and less waste than

ever before with other machines. It threshed from 20 to 30 bushels of wheat per hour, and twice as much of oats.

[From N. Olney, Esq., of Portage, N. Y.]

Messrs. WHEELER, MELICK, & Co.—You ask my opinion in regard to your *Thresher* & *Winnower*, but as two of my sons and one of my neighbors have given you some details, I will merely say that in my opinion your machine will do better work than any other I ever used, although I have used many different kinds for the last 20 years.

[From a second letter of E. French, Esq., of Bridgeport, N. Y., dated March 9, 1852.]

Messrs. WHEELER, MELICK, & Co.—I am not able to do your *Winnower* the justice it deserves. I have used it since August, and it has earned \$500 without asking for work, while other machines have been begging for it. I have had a man running it who has an eight-horse machine of his own, and good of its kind; but he could not get work with it. I have taken pains to exhibit the operation of your machine, and have seen none but pronounce it the most perfect in use. It has threshed 25 bushels per hour, and is capable of threshing 200 bushels per day, of good wheat. My wheat was of the *Southern* variety. I sold it from the machine for seed, without other cleaning. Oats it will clean better than any *Fanning Mill* I ever used.

[From E. T. Tiffany, of Dimock, Pa.]

Messrs. WHEELER, MELICK, & Co.—I consider your combined *Thresher* and *Winnower* one of the best machines ever introduced into Northern Pennsylvania. I have used one of them through December and a part of January, and did more business than any other four machines in this place. With a good team I can thresh 400 bushels of oats per day, and I think with an exchange I could thresh 500 or 600, and with less waste and expense than any other machine in existence. Could I get experienced workmen, I would order one or two more. It would be the best investment I could make. I can make better profit with one of your machines than can be obtained from any two farms in Susquehanna county. Your *Thresher* and *Winnower* receives the highest approbation of our farmers.

[From Samuel Tucker, of North E vans, N. Y.]

Messrs. WHEELER, MELICK, & Co.—In reply to your request about the *Thresher* and *Winnower*, I am ready to answer that it works well. Indeed, its equal was never seen in Erie Co. I have threshed 18,794 bushels of wheat, oats, and barley, besides 50 bushels of grass seed. A number of my neighbors want machines like mine.

Price of *Double Power Thresher* & *Winnower*, \$225

The superiority of *WHEELER'S PATENT RAILWAY CHAIN HORSE POWER, and OVERSHOT THRESHER and SEPARATOR* is universally acknowledged.—Thousands of them are in use, many of which have threshed from 50,000 to 100,000 bushels of grain, and are still in good

condition. Probably more than four times as many of these machines were sold during last year, as of any other kind. They are beyond doubt the most durable and economical machine in use. Their capacity has been tested by repeated trials as well at the New York and Pennsylvania Fairs, as on several private occasions, in competition with another machine made in this city which has been advertised to be far superior to ours, and in every instance the result has been about *one-third*, and in some instances more, in favor of our machines. In every case except one where we have submitted our machine to a *working* test at Fairs, it has taken the highest premiums, and in that excepted case the Committee decided that our machine performed its work in 8 minutes and its competitor in 11 $\frac{3}{4}$ minutes, being nearly *one-third* in favor of ours.

We have also exhibited ours in competition with the same machine at the State Fairs in Ohio, Michigan and Pennsylvania, and also at the Provincial Fair in Upper Canada, at all of which we received the highest premiums, viz: In Ohio, a Silver Medal and Diploma; in Michigan, \$29; in Pennsylvania, \$10; and in Canada, a Diploma.

We have numerous similar testimonials from County Societies, where we have always received the highest premiums awarded to Chain Powers.

Price of One Horse Power, Thresher, Separator and
Belting, \$120
Two Horse Do. 145

Besides the above, we manufacture and keep constantly on hand among other articles, Clover Millers, Straw and Stalk Cutters, Portable Saw Mills, (adapted to Horse Powers,) and Single Powers with Churn Geer attached. These last are extensively used in large Dairies, and are so arranged that the Power is used at pleasure for either threshing, churning, wood sawing, or other purposes.

All machines made and sold by us are warranted to give satisfaction or they may be returned, after a reasonable time for trial.

Orders are solicited and will be promptly filled.

WHEELER, MELICK & CO.

Corners of Hamilton, Liberty and Pruyn Streets,

(Near the Steamboat Landing,) Albany, N. Y.

May, 1852.

The Subscribers have obtained from Messrs. Wheeler, Melick & Co. of Albany, the exclusive sale and general agency in Rochester and Western New York, of their celebrated Agricultural Machines, which we will sell at their Albany prices, adding transportation.

J. RAPALDE & CO.

New York Agricultural Warehouse

A. B. ALLEN & CO.

189 & 191 Water Street, New York.

PLOWS of a great variety of patterns and different sizes calculated for sward and stubble land, wet meadows and recently drained swamps, where roots abound. Among these plows, also, are the deep-breaking-up, flat-furrow, lap-furrow, self-sharpening, side-hill, double mould-board, corn, cotton, cane, rice, and subsoil, with single or double wings.

HARROWS—Triangular, Square, Geddes, and Scotch.

ROLLERS with iron sections one foot long, and of different diameters. These can be arranged on an iron shaft of any width.

CULTIVATORS of upwards of twenty different kinds, steel tooth and cast iron.

SEED SOWERS of six different kinds and prices.

HOSE POWERS—Endless chain and circular, of wood or cast iron.

THRASHERS, with or without Separators.

GRAND MILLS of cast iron, and burr stone, to work either by hand, horse, or water power.

CORN SHUELLERS, single and double, large and small, cylindrical to work by hand, or otherwise.

STRAW CUTTERS with spiral, straight, or circular knives.

VEGETABLE CUTTERS, for turnips and other roots, together with a great variety of all other Agricultural and Horticultural Implements kept in the United States, such as hoes, shovels, spades, rakes, manure and hay forks, grain cradles, scythes, snaths, &c., &c.

CASTINGS of all kinds, for plows, cotton gins, and rollers.

WAGONS and CARRS, for horse, ox, or hand.

STEAM ENGINES, for Farm and other purposes.

Our Implements occupy three large stores, and we believe they make up the largest and most complete assortment in America. In addition, we have a machine shop employing upwards of one hundred men, where any articles in our line can be made to order.

A. B. ALLEN & CO.,

Feb., 1851.

189 and 191 Water St., New York.

LEWIS G. MORRIS'

THIRD ANNUAL SALE, BY AUCTION,

OF

IMPROVED BREEDS OF DOMESTIC ANIMALS,

Will take place at Mount Fordham, Westchester Co., (11 miles from City Hall, New York.) on WEDNESDAY, JUNE 9, 1852. JAMES M. MILLER, Auctioneer.

APPLICATION need not be made at private sale, as I decline in all cases, so as to make it an object for persons at a distance to attend. Sale positive to the highest bidder, without reserve.

Numbering about fifty head of Horned Stock, including a variety of ages and sex, consisting of Pure Breed Short Horns, Devons, and Ayr-hires; Southdown Buck Lambs, and a very few Ewes; Suffolk and Essex Swine, Catalogues, with full pedigrees, &c., &c., will be ready for delivery on the first of May—to be obtained from the subscriber, or at the office of any of the principal Agricultural Journals or Stores in the Union. This sale will offer the best opportunity to obtain very fine animals I ever have given, as I shall reduce my herd lower than ever before, contemplating a trip to Europe, to be absent a year, and shall not have another sale until 1854.

It will be seen by reference to the proceedings of our State Agricultural Society, that I was the most successful exhibitor of Domestic Animals, at the late State Fair.

I will also offer a new feature to American breeders—one which works well in Europe; that is, *letting the services of male animals*; and will solicit propositions from such as see fit to try it. **Coxpartners**—The animal hired, to be at the risk of the owner, unless by some positive neglect or carelessness of the hirer; the expense of transportation too and from, to be borne jointly; the term of letting, to be one year or less, as parties agree; price to be adjusted by parties—to be paid in advance when the bull is taken away; circumstances would vary the price; animal to be kept in accordance with instructions of owner before taking him away.

I offer on the foregoing conditions, three celebrated prize bulls, "Major," a Devon, nine years old; "Lamarine," a Short Horn, four years old; "Lord Eryholme," Short Horn, three years old. Pedigrees will be given in Catalogues.

At the time of my sale, (and I would not part with them before,) I shall have secured two or three yearly sets of their progeny; and as I shall send out in August next a new importation of male animals, I shall not want the services of either of these next year. I should not sell them, as I wish to keep control of their propagating qualities hereafter.

I also have one imported buck, the prize winner at Rochester last fall, imported direct from the celebrated Jonas Webb; and also five yearling bucks, winners also, bred by me, from bucks and ewes imported direct from the above celebrated breeder. They will be let on the same conditions as the bulls, excepting that I will keep them until the party hiring wishes them, and they must be returned to me on or about Christmas Day. By this plan, the party hiring gets rid of the risk and trouble of keeping a buck the year round. All communications by mail must be prepaid, and I will prepay the answers. L. G. MORRIS.

Mount Fordham, April, 1852.—5-21.

Wood's Renovating Salts.

THE subscribers are now receiving large quantities of this valuable manure put up in barrels, which we will sell at one cent per lb.—no charge for barrels.

This article is made from the following ingredients, viz: Potash, Bone Dust, Bone Coal, Plaster, Glauber Salts, Saltpetre, Oil of Vitriol, Salts of Ammonia, Gas Liquor, and Bullocks' Blood. For sale at the State Agricultural Warehouse, No. 25 Cliff street, New York.

LONGETT & GRIFFING.

We hereby certify, that our Renovating Salts are composed of the ingredients represented, and pledge ourselves to refund the money in all cases, to purchasers who can produce satisfactory proof to the contrary. Wood & Co.

New York, March, 1, 1852.

[4-21]

Field and Garden Seeds.

OLOVER, Large Clover, Timothy Seed, Blue Grass, Red

Top, Ray Grass, White Clover, and Lucerne.

Garden Seeds—Ruta Baga, Turnep, Calbage, Beet, Carrot, Parsnep, Peas and Beans of every variety.

Fruit and Ornamental Trees—Having been appointed agent for one of the best nurseries in the country, we are prepared to execute orders at short notice.

LONGETT & GRIFFING.

25 Cliff Street, New York.

[4-21]

Prices of Agricultural Products at the Principal Markets in the United States. — Apr 19, 1852.

	New York.		Boston.		Rochester.		Chicago.		Cincinnati.	Philadelphia.	
Beef, per 100 lbs.	\$5.75	a 6.75	\$6.00	a 7.50	\$4.00	a 5.00	\$4.00	a 4.25		\$4.25	a 5.75
do mess, per bbl.	9.75	12.75	12.00	13.00	10.00	10.50	10.50	4.12½		14.50	15.50
Pork, per 100 lbs.					6.00	7.00	4.00	4.25			
do mess, per bbl.		18.00	18.00	18.50	17.00	17.50	16.00	16.50	\$14.50	a 16.50	16.50 18.00
Lard, per lb.		9 9½	10	12	10	10½	7½	8	6¼	9 9½	9½ 10½
Butter, do	18	30	22	28		20	7	8	9	16	14 16
Cheese, do	6½	8	6	8		5	7	6½	3.22	4.25	5.75
Flour, per bbl.	4.63	5.75	4.75	5.75	4.50	5.00	3.50				
Wheat, per bush.	95	1.12	1.00	1.25	94	93	60	70	61	63	96
Corn, shelled, per bn.	65	66	61	65	48	50	23	24	25	28	61 61½
Rye, do	74	76	72	74	56	60			50	54	72 73
Oats, do	38	43½	40	43	34	36	17	18		22	88 40
Barley, do	75		75	65	70				30	40	
Clover seed, do 8 pr. lb.			9 a 11	per lb.	4.50	5.50	12½	per lb.		5.00	4.25
Timothy seed, do 16.18 per tec.					2.00	3.00	2.25		1.50	2.25	2.75 3.00
Flax seed, do 1.20 1.80			1.20	1.37	1.25	1.50	1.00			1.00	1.25 1.80
Hay, per ton	11.50	12.00	11.50	12.00	7.00	11.00			8.00	13.00	
Wool, per lb.	30	44	31	46	30	40	30	40	26	35	52½
Wood, hard, per cord					4.00	5.00	3.25	5.00			

CONTENTS OF THIS NUMBER.

Irrigating and Manuring Land by Steam Power,..... 137
 Summer Fallows,..... 139
 Peas,..... 140
 Interesting Experiment,..... 142
 Butter and Cheese Making,..... 143
 Farming in Kentucky,..... 146
 COMMUNICATIONS AND EDITORIAL NOTES.—Lie on Cattle; Guano; Bog Lime; Manure dropped in Summer,..... 147
 Stall Feeding Sheep; To Dissolve Bones; Superphosphate of Lime, and Mangel Wurzel; Treatment of Sandy Soils; Sweet Potatoes,..... 148
 CONDENSED CORRESPONDENCE.—Winter Barley; Grubs on Melon Vines; Recipe for curing Sores; Potato Culture; Virginia Land,..... 149
 White Beans; Hedges; Farming in Edgar Co., Ills.,..... 150
 Large and Small Potatoes for Seed,..... 151
 Chinese Hogs,..... 152
 Mummy Wheat,..... 153
 Wright's Premium Horse-Hoe,..... 153
 LADIES' DEPARTMENT.—Phlox Drummondii,..... 159
 EDITOR'S TABLE.—Inquiries and Answers; Notices; &c., 160

HORTICULTURAL DEPARTMENT.

Liquid Manure,..... 154
 Dwarf Apple Trees; Memoranda of the Season,..... 156
 Fruit Culture in Indiana; Horticultural Society of Pittsburgh; Hort. Society of the Valley of the Genesee. 157
 Grape Vine Malady,..... 158
 Answers to Correspondents,..... 161

ILLUSTRATIONS.

Chinese Hogs,..... 152
 Mummy Wheat,..... 153
 Wright's Premium Horse-Hoe,..... 153
 Dwarf Apple Tree,..... 156
 Phlox Drummondii,..... 159

Improved Stock.

CATTLE of the Durham, Devon, Hereford, Alderney, and Ayrshire breeds.

SHEEP of the Native and French Merino, Saxony, South Down, and Cotswold.

PIGS of the Lincoln, Suffolk, and Berkshire breeds.

From our long experience as breeders and dealers in the above kinds of stock, and our excellent situation for purchasing and shipping, we think we can do as good justice to orders, as any other house in the United States.

A. B. ALLEN & CO.,

April 1, 1852—4f. 189 and 191 Water st., New York.

Field and Garden Seeds.

WE have recently imported from England, France and Germany, and have grown in the United States, expressly for us, a fine assortment of the best and most approved kinds of Field and Garden Seeds.

Agricultural and Horticultural Implements, a large assortment of the various kinds suitable for North and South America.

A. B. ALLEN & CO.

April, 1852—4f. 189 and 191 Water st., New York.

The Journal of Agriculture,

A SEMI-MONTHLY Periodical of 32 pages. Edited by WILLIAM S. KING, Prof. J. J. MAPES, and A. W. DODGE, Corresponding Secretary of the Massachusetts Board of Agriculture. Published at Nos. 8 and 10 Gerrish Block, Blackstone Street, Boston. TERMS—\$2 per annum; Four copies \$6; Ten copies, \$14. The money must always accompany the order.

Among the principal contributors are M. P. Wilder, President Massachusetts Board of Agriculture, Dr. Charles T. Jackson, Levi Bartlett, John W. Proctor, President Essex Agricultural Society, Samuel Walker, President Massachusetts Horticultural Society, J. E. Teschemaker, S. H. Huntington, Hartford, T. B. Miner, Author of American Bee Keeper's Manual, Rev. J. L. Blake, D.D., Author of Farmer's Every-day Book, &c., Rev. W. Chitt, and many other well known writers and practical men.

Good Agents wanted in all parts of the country. Address WILLIAM S. KING, 8 and 10 Gerrish Block, Blackstone st., Boston, Mass. April, 1852—2f.

Clover and Timothy Seed.

NOW on hand and for sale at the Genesee Seed Store and Agricultural Warehouse, 63 and 65 Buffalo St.

500 bushels good Timothy Seed.

200 " prime Clover.

Rochester, April, 1852.

J. RAPALJE & CO.

The Practical and Scientific Farmer's own Paper.

THE GENESEE FARMER,

A MONTHLY JOURNAL OF

AGRICULTURE AND HORTICULTURE,

ILLUSTRATED WITH NUMEROUS ENGRAVINGS OF Farm Buildings, Domestic Animals, Implements, &c.

VOLUME XIII, FOR 1852.

DANIEL LEE & JAMES VICK, JR., EDITORS.

P. BARRY, Conductor of Horticultural Department.

Fifty Cents a Year, in Advance.

Five Copies for \$2—Eight Copies for \$3, and any larger number at the same rate.

All subscriptions to commence with the year, and the entire volume supplied to all subscribers.

Subscription money, if properly enclosed, may be sent (post-paid or free) at the risk of the Publisher. Address to

DANIEL LEE,

December, 1851.

Rochester, N. Y.

POSTAGE ON THE GENESEE FARMER.—50 miles or under, five cents per year; exceeding 50 miles and not over 300, ten cents; exceeding 300 and not over 1000, fifteen cents; exceeding 1000 and not over 2000, twenty cents; exceeding 2000 and not over 4000, twenty-five cents; for any distance exceeding 4000, thirty cents.

STEREOTYPED BY J. W. BROWN, ROCHESTER, N. Y.

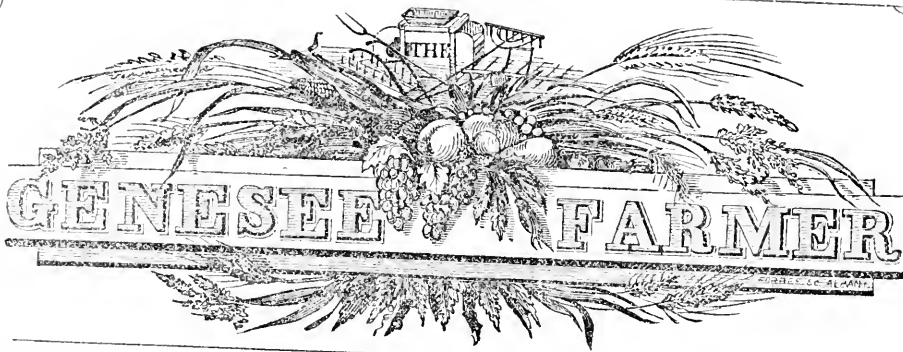

VOL. XIII.

ROCHESTER, N. Y., JUNE, 1852.

No. VI.

OBSERVATIONS ON THE GROWTH AND NOURISHMENT OF PLANTS.

No nation has produced more scientific ideas relating to agriculture, than the United States; but owing to various causes, the chief of which is the want of popular appreciation and sympathy, these valuable ideas have been universally neglected, and nearly fruitless. The truth of this statement has been strongly impressed on our mind by reading a short paper "On the Growth and Nourishment of Plants," by Mr. EZRA L'HOMME-DIEU, Vice President of the Society for the Promotion of Agriculture, Arts, and Manufactures; organized in 1791, and chartered by the Legislature of New York in 1793; which was written near the close of the last century. But few copies of the Transactions of this Society were printed, and it is due to the agricultural literature of the country that some of its most useful articles be reproduced for the instruction of the present generation. Chancellor LIVINGSTON was President of the Society from its beginning till his lamented death, in 1813; and nearly all its essays were from the pens of the ablest men this State or nation can boast. So high is our estimation of the science of Mr. L'HOMME-DIEU at that early day, and before LIEBIG was born, that we copy with the pen, and publish the whole of his "Observations" above referred to, for future use.

"In considering the growth of plants and vegetables, we shall inquire, so far as we are able, into their food or nourishment; and in doing this, shall endeavor to go no further than we can be justified by facts and appearances. I believe we are on safe ground when we say that the plant receives no nourishment from the earth. Many have been the experiments of raising plants, shrubs, and trees, in boxes filled with earth; and this earth being weighed after the shrub or tree had grown to maturity, (as the orange and lemon tree,) and after taking out the tree, the dirt is not found to have lost any of its weight. It thence follows that the earth is only a bed to hold up the plant or tree, that it may receive its nourishment from some other source; and the difference between good land and poor land consists only in the position of its parts, so as to enable the plant or tree to receive nourishment from different resources better in the one than in the other, although neither afford any in themselves.

"The next inquiry will then be, What is the food of Plants? and the last, By what means is this nourishment received?

"If we leave out earth, there will remain only the two elements water * and air that can afford nourishment necessary for the food and growth of the vegetable creation: for it is supposed in this theory, that manures of any kind afford no nourishment to the plant, but only answer for the purpose of altering those parts of the earth in such a manner as is best calculated for the extension of roots, and reception of the water and air; or by attractions of such parts of the atmosphere as are food for plants, or, by the emission of fixed and other air, of which they are peculiarly possessed, add to vegetation. If we suppose, as some philosophers have lately endeavored to prove, that water is formed from air, and of which there appears to be great probability, there will then be in fact nothing but air in some shape or other, from which vegetables can derive subsistence. But at this we shall not be surprised when we consider the atmosphere as a vast laboratory, in which nature as the operator performs immense productions of various kinds, suitable for the nourishment of every species of the vegetable creation, and is the grand receiver in which the decomposition of all bodies, and the various kinds of air arising from them, are received, mingled, combined, and separated, *not by chance*, but by

* As a small proportion of earth is found in all water, and a small proportion of earth in all plants, being analyzed, it is not designed to exclude this earth, [the ash of plants,] found in all water, from the nourishment of plants.

infinite Power and Wisdom. Chemists are agreed in one general opinion, which has been satisfactorily proved, that, supposing the air in general, or atmospheric air, to consist of 100 parts, only about 28 of those parts are adapted to the support of animal life; the other parts are for the nourishment of vegetables. We see vegetables grow more rapidly in cities than in the country, which confirms the theory; as in cities the air has a greater proportion of putrefaction, consequently more of that kind of air suitable for the growth of plants than in the country. We further observe, where a compost is made of putrefying substances, as fish for instance, *vegetables at a distance from the heap of compost grow luxuriantly*, which must be from the purified air proceeding from the compost, and absorbed by the leaves or blades of the vegetables. We frequently see in flower pots hyacinths and other vegetables growing rapidly and coming to perfection, supported by the mouth of the flower pot, the pots being filled with water only, in which we see the roots growing and extending in proportion to the stalks, leaves, and flowers. Here the plant receives all its nourishment from the air and water imbibed by its roots and branches. The *sedum aucampsceros*, or evergreen, too, we frequently see hung up by a thread, growing very well without any water, and nourished only by the air. It can not be thought more strange that the air should change into a plant, shrub, or tree, or *any other body*, than that they should be decomposed and return to air again. This we see performed every day: for instance, the candle by which I now write is continually diminishing and returning to the great reservoir of nature, and there being worked up, will become the food of vegetables, which being eaten by the ox becomes a part of his tallow, and it being made into candles, may at a future period afford me light to write a second time. If our theory be true, it follows that all vegetables are produced in their great variety by different kinds of air, which the chemists of the present day would call inflammable air, vital or pure air, and mephitic or impure air. These different airs being combined in the different organic strainers in a manner yet inexplicable, composes their different substances, and supports them in their vegetation, growth, and propagation. By some late experiments it appears that fixed air, called by chemists *carbonic gas*, and is the same air which makes beer or cider foam when poured out of a bottle into a glass, or which makes the emptyings or yeast raise the flour, or the springs of Saratoga and Ballston do the same, *is very favorable to vegetation*.

"Ashes have a very powerful effect in the southern part of the State, as a manure, although they are not a putrified substance. The salts of ashes, called by chemists alkali, have the power of attracting the nitrous air from the atmosphere in great abundance. This is seen by boiling water leached from earth taken from covered places, where as soon as you add a little lye from ashes, the *nitre*, which before adhered to the earthy parts in the water, immediately disengages itself from the earthy parts suspended in the water, and adheres to the lye, which makes the salt-petre we use, and which is one of the most powerful manures. Again, if a heap of dirt is put under cover and frequently sprinkled with lye, the attraction of nitre from the atmosphere will be so great, that in a short time the heap will be covered with nitre, in appearance to hoar frost. This nitre is part of the air, [true,] and being found by experience to be good manure, must be a part of the vegetable production, which when decomposed, or becoming dissolved by putrefaction or otherwise, returns again into the air. The fixed air (carbonic acid) escaping from all fermented, vegetable substances, as well as from those which are in a putrifying state, shows that fixed air composed a considerable part of their substances, and consequently must be one of the *best* manures.

"If we extend our ideas a little further, and consider that all flesh is grass, as the inspired writer expresses it, and may be literally true, we may safely conclude that all animals as well as vegetables are composed of air and water. The grass is nourished and comes to perfection by these elements, the ox eats the grass, and the man not only eats the ox but vegetables also; and by the various organizations of the plant, ox, and man, their different substances are produced, being originally from the air and water. Dr. PRISTLY, by his important discoveries, has greatly added to the knowledge of analyzing the air, which is found capable of being divided and separated into all its different parts, and has become a great source of useful knowledge to the world. Physic has been greatly improved by these late discoveries, and by it *persons have been restored to health as by miracle*. The philosophic mind has been delighted in the experiments, in contemplating those marvelous works of nature, which are upheld and directed by infinite Power and Wisdom. The agricultural interest, too, experiences the beneficial effects of these discoveries in procuring manures, by which subsistence for man is afforded from old and worn out fields."

It is worthy of note that, fifty-five years ago, farmers in the Hudson and Mohawk valleys had occasion to complain of "old and worn out fields;" and why? Because they, like their descendants in our day, thought that the systematic study of nature's laws in their connection with agriculture, was time and money thrown away. Had L'HOMMEDIEU, MITCHELL, LIVINGSTON, DE WIT, WATKINS, BECK, CLINTON, VAN RENSSELAER, and others, been sustained in their patriotic efforts to elevate tillage and husbandry to the dignity of an educated and honorable profession, this whole Republic would now be something like a Paradise to live in. But instead of encouraging the application of science to agriculture, there is not one acre of arable land in the United States dedicated to experimental purposes for the advancement either of the science or

the practice of rural economy. For what little we have learned since the above was written in the eighteenth century, we are indebted to the agricultural schools and professors of Europe. We have lost a half century in agricultural progress; for without genuine science there can be no substantial progress. Every school boy should know that practice alone only repeats what practice had before done, so that progress is impossible. An experiment is a search after a thing unknown, or it is no experiment. Such an investigation is prompted, not by practice, but by theory. Theories differ as widely in value as agricultural practice; but while most cultivators are quick to discover defects in practice, all theories of farming appear to them alike worthless, *except their own*. To have a sound theory, one needs large experience in rural affairs, and to be well read in the literature and sciences that appertain to agriculture. Such an one must know that the damage annually done to American soil can not be repaired by any known process for less than three hundred and thirty-six millions of dollars; and that, as the crops grown and removed increase rapidly from year to year, the injury increases in the same ratio. The alkalis that draw nitre from the air, as stated by L'HOMME-DIEU, are now extracted from 112,042,000 acres, and thrown into rivers, lakes, and the ocean, to improve the soil!

In Europe, where ashes are less abundant than in this country, they are extensively used for making artificial nitre beds in conjunction with manure. In forming such beds, care is taken to leave open passages under them for the free passage of air, from which nitrogen is absorbed in forming the nitric acid which combined with potash produces saltpetre, and united to soda forms cubic nitre. To extract the food of plants from the atmosphere, and retain it in the soil in a condition to meet the wants of plants, all alkadies (potash, soda, and ammonia,) and alkaline earths (lime and magnesia,) are invaluable. It is this fact that makes us regret the constant waste of alkadies on farms, in villages, and in cities. Some fancy theorists teach, that barely shading the ground will develop a nitre-bed anywhere, as though potash could be extracted from pure sand or pure clay. This mineral is no better husbanded now in the United States by the mass of citizens in cities and rural districts, than it was sixty years ago; nor is the production of saltpetre in barnyards better understood now than in the time of L'HOMME-DIEU. No satisfactory experiments have been made during the first half of the present century in drawing the nourishment of cultivated crops from the atmosphere, and hence no advancement in knowledge has been achieved in that direction.

MIXING SOILS AND MANURES.

AN acre of soil, estimated to the depth of ten inches, weighs usually not far from a thousand tons. It is a heavy dressing of common stable manure, equal to thirty loads of over a ton each, which supplies ten tons of solid matter to the acre. Admitting that one applies that quantity, every one hundred grains of soil to the depth of ten inches should have one grain of finely divided manure intimately blended, and perfectly incorporated with it. This is the ideal of garden culture, in which well rotted manure and deep and frequent tillage form a soil of exceeding fertility. In ordinary farming, the manure goes into the ground in comparatively large and isolated masses, while hundreds of pounds of earth may be found without a particle of the applied fertilizer within it. In one place, the roots of plants have an excess of manure; and in another, they are in a starving condition. If it is bad to do without any manure, it is but little better, and often worse, to make so unwise a use of this food of crops. Manure is the elixir of vegetable life—the very “salt of the earth.” How, then, ought manure to be prepared? How applied to tilled land, meadows, and pastures?

If all soils, all climates, all manures, and all crops, were alike, nothing would be easier

than to lay down rules for the preparation and use of manure, to which there could be but few exceptions in practice. No such uniformity in circumstances exists; and on that account, very much must be left to the sound judgment of the husbandman. There can be no reasonable doubt that manure dissolved in water (a weak solution) can be most evenly diffused through the whole mass of soil to which it is applied. Water holding the organic and inorganic aliment of plants in solution, permeates the earth wherever it is possible for roots to extend. In this condition, their daily nourishment is always ready for use; but when a mass of raw, insoluble dung or vegetable matter, is buried in the earth or spread upon its surface, the case is entirely different. In time, this solid will dissolve; but being in large lumps, the sand, clay, and mould that immediately surrounds the manure, will imbibe it all and leave three-fourths of the soil as devoid of fertilizing atoms as it would be had no manure been spread on the land. All who are familiar with agriculture in districts where the soil is naturally thin, and frequently badly worn, must have seen grass, grain, and other crops, grow in bunches on partially manured fields. This is owing to the extreme unevenness with which the fertilizers have been applied—some plants (a very few) have a feast, others a continuous fast. In all such cases, the manure does not do half the good to the land and its crops that it is capable of; and nothing in tillage and husbandry more needs reform than the defective manner in which soils and manures are mixed together. Composts so covered with loam, mold, ashes, and charcoal, as to lose none of their gases, nor soluble salts, should be rotted sufficiently to break up into fine particles before spreading, plowing in, and harrowing. In this way alone can one readily incorporate manure with clay, sand, and mold, so that it will wholly disappear.

But it is frequently inconvenient to wait for manure of any kind to rot before it is used; and it is desirable to know how it can be best applied. It should be spread with much greater care, broken finer, and distributed even, than is generally practiced. This rule holds good whether dung is applied as a top-dressing to meadows and pastures, or to plowed, or about to be plowed, lands. The equal diffusion of the fertilizer through the body of the soil from its surface down to the depth at which the roots of crops descend, is the perfection of manuring by the aid of any given quantity. Its extreme division greatly favors its solution in the earth, and the proper feeding of the farmer's needy crops. Some say that the natural tendency of fertilizers is to rise to the surface, and therefore manure should be covered deep with the plow; while others contend that manure naturally sinks with the water that descends to form springs, or runs out in under-drains; and therefore manure should be covered only two or three inches in depth. Both of these statements are partly true and partly erroneous. All the dissolved food of plants both ascends and descends around their roots to nourish and support vegetation. The evaporation of water from the surface of the ground, and from the numerous leaves of plants and forest trees, induces an upward movement of water from the subsoil; but when it rains, or from any cause there is more moisture in the surface soil than in the earth below it, water descends and manure with it, if soluble and present on the surface. The droppings of all animals in a state of nature enrich the land without the aid of the plow or harrow, or being covered with earth. Art and science undertake to do more than unaided nature accomplishes; and a large increase of physical as well as other comforts, is attained. But for some reason, the art and science of agriculture are less studied, and less investigated in a philosophical way, than any other in the whole range of useful knowledge and occupations. The nice adaptation of manures to the peculiar wants of every crop, is a point in farm economy now universally neglected. Defects in soils are attracting some attention; but how to remedy these defects in the cheapest manner, is a desideratum that can never be realized until there is more system in our vague and meaningless researches as practical farmers. What new truths did the three millions of agriculturists in this country develop in the year 1851?

PLOWING IN GREEN CROPS.

WHEN a plant is burnt in the air, the ashes which remain are termed by chemists the *inorganic* constituents; that which is burnt away, the *organic*: and though this definition is not strictly correct, it is sufficiently so for all practical purposes. The great store-house of the *organic* elements of plants, is the atmosphere; the *inorganic* elements are obtained by plants only from the soil. The amount of produce which a soil destitute of organic matter will annually yield by the disintegration of its inorganic elements, may be considered the *natural yield* of the land. What that amount will be, will depend, within certain limits, on the abundance or scarcity of these mineral constituents of the plants grown; but plants can not grow at all without organic matter, or those elements which the atmosphere will supply. Now, in what quantity will the atmosphere supply these to the plants, providing there is a sufficiency of mineral matter? This depends on the kind of plants, the length of the growing season, and the quantity of rain and number of rainy days in that season. It has indeed been supposed by some eminent chemists, that the atmosphere would supply an *unlimited amount* of organic constituents to the plants, and that therefore the yield of any given crop would be in exact proportion to the quantity of inorganic matter existing in the soil in an assimilable condition;—that, if there were only mineral elements sufficient in an acre for five bushels of wheat and straw, only five bushels would be grown; but if there were sufficient for fifty bushels, a produce of fifty bushels per acre would be obtained. To the first proposition we of course agree, thinking that up to the amount of produce for which the atmosphere supplies sufficient organic matter, the yield will be in exact proportion to the mineral matter available in the soil; so that the point at issue between the “mineral theory” and “ammoniacal theory” advocates, is, the *amount* of organic matter which the atmosphere annually supplies to certain crops,—and there is no subject of more importance connected with agricultural chemistry, affecting as it does the reason of all our systems of agriculture, rotation of crops, the value of manuring substances, and in fact everything connected with agricultural operations.

Without therefore attempting to settle the question as to whether soils are easily exhausted of their mineral constituents or not, we will give some results of experiments by Mr. LAWES, that, so far as wheat is concerned, entirely satisfy us that to obtain *large crops*, it is absolutely necessary to *supply organic matter* in the soil; or, in other words, that the atmosphere will not supply sufficient organic matter for a *large crop* of wheat.

The experiments were commenced in 1843. The soil a rather heavy loam, or what is generally known as a good wheat soil. Four grain crops were taken from the field the four years preceding the experiment, without any manure of any kind being supplied. The field devoted to the experiments contains fourteen acres. It is divided into thirty-three portions, which have been sown with wheat (and the whole crop of wheat and straw removed) every year. One plot has been left unmanured since the commencement; another supplied with fourteen tons of barn-yard manure per acre each year, and one with the ashes of fourteen tons of barn-yard manure; some with “Liebig’s Patent Wheat Manure,” and others with all kinds of chemical mineral manures, alone and in various combinations; some with rice at the rate of one ton per acre, rape cake in various quantities, and sulphate and muriate of ammonia alone and in conjunction with all kinds of mineral manures. The detailed results of such extensive experiments can not of course be given; and in fact, a mere summary of them would occupy more room than our space will admit. Suffice it to say, then, that the *average* yield of dressed grain per acre, of seven successive crops on the continuously unmanured plot, was $17\frac{3}{4}$ bushels. The average yield of nine plots, the first year dressed with a variety of artificial mineral manures corresponding to the ash of wheat and straw, was $16\frac{3}{4}$ bushels.

The ashes of fourteen tons of barn-yard manure, gave 16 bushels. The average of the seven years on the plot dressed with fourteen tons of barn-yard manure per acre each year, was 28 bushels. An acre dressed with 168 lbs. each of sulphate and muriate of ammonia, gave $32\frac{1}{2}$ bushels; another, with 150 lbs. each of sulphate and muriate of ammonia, $25\frac{3}{4}$ bushels; while a plot by the side of it, dressed with 150 lbs. each of sulphate and muriate of ammonia, and 300 lbs. potass, 200 lbs. soda, 100 lbs. sulphate of magnesia, 200 lbs. calcined bones, and 150 lbs. sulphuric acid, gave 25 bushels. Again, with 200 lbs. each of sulphate and muriate of ammonia, we get $32\frac{3}{4}$ bushels; while 300 lbs. potass, 200 lbs. soda, 100 lbs. sulphate of magnesia, and 200 lbs. calcined bone dust, with 150 lbs. sulphuric acid, gave $17\frac{3}{4}$ bushels. 224 lbs. sulphate of ammonia gave $27\frac{1}{4}$ bushels. 224 lbs. sulphate of ammonia, and the ashes of three loads of wheat straw, gave 27 bushels.

These results, which we have selected as showing the general indications of the experiments, will throw much light on our point—What amount of organic matter will the atmosphere supply to a wheat crop on a soil having an abundance of inorganic constituents? The average crop on the continually unmanured acre was $17\frac{3}{4}$ bushels; and where *inorganic* or *ash constituents* were supplied, the crop was not increased. But when a salt of ammonia is used, the crop in some instances was doubled; and in no instance during the whole course of the experiments, has ammonia been used without *greatly increasing the crop*. On one acre where ammoniacal salts alone were used, the average yield of six successive crops was 27 bushels. This clearly shows that there was abundance of inorganic matter in the soil, but that for want of organic matter the plants could not assimilate them. It can not be said that the wheat was not in favorable circumstances for collecting organic matter from the air, for the land was always plowed twice previous to sowing, and during the spring the crop was hand-hoed twice, and sometimes thrice, care being taken to have all the plots hoed at the same time and treated similarly in every mechanical operation.

We therefore conclude that, though a soil has an abundance of every inorganic constituent of the wheat plant in an available condition for 40 bushels per acre, yet if there is not a corresponding sufficiency of organic matter, but the plant is dependent solely on the atmosphere, a crop averaging about 17 bushels only will be obtained; and this may be considered the natural yield of a soil, organic matter being derived from the atmosphere sufficient for this amount. If we wish to increase this yield, we must get an artificial supply, or an accumulation, of organic matter in the soil; and as organic matter consists of four elements—oxygen, carbon, hydrogen, and nitrogen—it is important to know which of these is the most essential. In the experiments above given, where 14 tons of barn-yard manure were each year used per acre, an average crop of 28 bushels was obtained; and where ammoniacal salts alone were used for six years, an average of 27 bushels. Now, besides a large amount of *inorganic matter*, the 14 tons of barn-yard manure contained an immense amount of organic matter—carbon, oxygen, hydrogen, and nitrogen—and from the fact that the ammoniacal salts alone did as much good as the minerals, carbon, and ammonia in the dung, we conclude that ammonia (hydrogen and nitrogen) is the only organic matter that need be supplied to the wheat crop. The rice, rape cake, and other carbonaceous manures used in the experiments, did good only in a corresponding proportion to the nitrogen they contained. So that, to increase our wheat crops over 17 bushels per acre, we must in some shape or other supply *ammonia*; or, what is equivalent, nitrogen.

To obtain this ammonia, is the great difficulty in the way of *increasing* our wheat crop. In Great Britain, immense quantities are purchased in the form of Peruvian guano, and sulphate and muriate of ammonia; and highly *nitrogenous* artificial foods are purchased for cattle, which make a manure containing a high per centage of ammonia. By this means their average wheat crop is nearly as much again as ours. Since

the introduction of free trade, and the consequent reduction in the price of agricultural products, it is asserted that this "high farming" is attended with low profits. Be that as it may, if the use of guano and the consumption of oilcake does not abate, it will be pretty good evidence that it is found profitable with prices but little higher than our own.

The reader will wonder what this has to do with plowing in green crops. Much, every way. The reason of the benefit of a crop of clover plowed in for a crop of wheat, is rather a difficult thing to see if we adopt the mineral theory; for there is no evidence to show but what the wheat plant can extract the mineral elements from the soil as well as the clover plant; and therefore, if there is inorganic matter for the clover, there is for the wheat: for both plants require precisely the same elements. It is said that clover roots descend further into the subsoil, and bring up these fertilizers from below, and thus supply the following wheat crop. But why will not the wheat roots obtain this?—we have seen several wheat roots six feet long, and one *nine* feet; and believe when the wheat plant is strong and healthy, that its roots descend as low as do those of clover.

Abandoning the mineral theory and adopting the ammoniacal one, we have at once a satisfactory reason for the benefit of clover and other green crops plowed in as a manure for wheat. To increase our crop of wheat, we must supply ammonia. Now, when we plow in a crop of clover, this is just what we do supply. We do not gain minerals by the operation, as they already existed in the soil, and some have perhaps been removed by a crop of hay the previous summer; but the clover obtains *ammonia* from the atmosphere, which becomes organized in the roots, stems, and leaves of the plant; and when they are plowed in, they decompose, and furnish ammonia for the wheat crop. A crop of red clover that would make a ton and a half of hay, would contain 60 lbs. of nitrogen, and according to the results of Mr. LAWES' experiments, would, if plowed in, increase the following wheat crop twelve bushels per acre; and this without taking the roots into consideration, which would probably contain half as much nitrogen as the last crop of clover. This would make *an increase of eighteen bushels per acre*, as the benefit of growing clover and plowing it in.

The proper time to turn in the clover, is just before flowering; it is then full of rich nitrogenous fluids: whereas, in the act of flowering, nitrogen is evolved, and the clover is not so good either for hay or manure. This fact will also indicate the proper time for cutting clover for hay. If allowed to stand until after it has flowered, not only will there be a loss of nitrogen, but the soluble saccharine matter will be converted into insoluble starch and innutritious woody fibre.

In deciding on the economy of plowing in clover for manure, or converting it into hay, we have to consider its effect on the wheat crop, the price of the wheat, the value of the hay, and what it would cost to obtain manure in some other way. We have just purchased guano in New York, for experimental purposes; it cost us there \$50 per ton; and if it contains 16 per cent. of ammonia, we shall consider it a first rate article. This is paying 15 cents per pound for ammonia. Now, we have said that a crop of clover which would make a ton of hay, would contain about 40 lbs. of nitrogen, equal to about 48 lbs. of ammonia. This at 15 cents per pound would be \$7.20, as the value of a ton of clover hay for manuring purposes; and if plowed in, it would increase the wheat crop 8 bushels. But there is another view of the subject. Besides nitrogen, clover contains a large amount of carbon, oxygen, and hydrogen, so united with each other and nitrogen as to form valuable food for animals, though the first three elements are not necessary as food for the wheat plant, as has been before shown. Now, if this clover is consumed at home by horses, sheep, &c., these elements will be used in the animal economy, and nearly all the nitrogen will be voided in the liquid and solid excrements, (principally in the former,) which, if carefully husbanded, can be returned to the field without much loss.

Besides clover, there are many other crops which are grown for plowing in as manure. Their value for such a purpose is always in proportion to the amount of nitrogen they extract from the atmosphere; and as all the cereals consume nitrogen rather than collect it, they should never be grown for this purpose. Such are oats, buckwheat, rye, corn, timothy, &c. Peas and tares collect large quantities of nitrogen, and might be profitably grown for the purpose of plowing in while green. Rape is often grown in England for plowing under; but it requires rich land to produce a good crop, and we can not recommend it. Spurry, white lupins, borage, and many other plants, are grown in Europe for manure; but none of them have been fairly tried in this country, and we therefore can not speak of their respective merits. On the whole, we know of nothing at present so well suited to our soil and climate, and so valuable either as food for stock or plowing in as manure for wheat, as red clover; and we would most earnestly recommend its more extensive culture in the place of the cereal timothy, especially on all wheat farms. We do not wish to see large crops of clover grown, converted into hay, and sold off the farm, unless manure be purchased in return in equal proportion, knowing that such a course must soon exhaust the land of the *mineral elements*; but if the clover is consumed on the farm by stock, or plowed in as manure, and nothing but the grain of wheat sold off the farm, we apprehend no such exhaustion.

THE FATTING QUALITIES OF DIFFERENT BREEDS OF SHEEP.

In deciding on the merits of any breed of sheep, it is of course necessary to consider the object for which they are specially kept — whether for wool, tallow, or mutton, and the relative prices of these products. Thus, in England, mutton seldom sells for less than twelve cents per pound, while the best refined tallow is worth but seven cents, and wool twenty four cents per pound. Under these circumstances, it is evident the farmer will keep that breed of sheep which yields the most mutton of a superior quality with the least consumption of food, while tallow and wool-making qualities will be minor considerations. In this country, the circumstances of the case are just the reverse — wool of the same quality is worth more here than in England, while tallow is usually worth twice as much as mutton.

We make these remarks to introduce to our readers some results of experiments recently published by Mr. LAWES, on the "Comparative fattening qualities of different breeds of Sheep;" and though only two breeds have yet been tried, the facts brought to light can not fail to interest our readers. The breeds taken were the Hampshire and Sussex Downs. Forty animals of each breed, selected from the best flocks in Great Britain, were placed side by side upon rafters, in a long shed. They were fed with oil-cake, clover hay cut fine, and ruta baga. The average weight of the Hampshire sheep when put up, (November 7,) was 113 lbs. per head; that of the Sussex sheep was 83 lbs. The amount of oil-cake and clover chaff allowed them was in proportion to their live weight. Thus, the forty Hampshires were allowed forty pounds of oil-cake and forty pounds of clover chaff per day; and to the Sussex, thirty-two pounds of oil-cake and thirty-two of clover chaff. Ruta bagas were allowed them *ad libitum*. The entire period of the experiment was twenty-six weeks. The average weekly consumption of ruta bagas per head of the Hampshires, was 106 lbs.; and of the Sussex, 79 lbs.: or, for 100 lbs. live weight of animal of the Hampshires, 71½ lbs.; and of the Sussex, 69 lbs. The average weekly increase per head was, of the Hampshires, 2 lbs. 12 oz.; and of the Sussex, 2 lbs. 2 oz.: or, for each 100 lbs. live weight of animal of the Hampshires, 1 lb. 14 oz.; and of the Sussex, 1 lb. 11 oz. From these figures it is evident the Hampshires lay on fat quicker than the Sussex; but the question is, which breed pro-

duces the most increase from a given amount of food. The following table will show the amount of food consumed by each breed, to produce 100 lbs. increase :

TABLE, SHOWING THE AVERAGE FOOD CONSUMED TO PRODUCE 100 LBS. INCREASE DURING THE PERIOD OF 26 WEEKS.

	Oil Cake.		Clover.		Ruta Baga
	<i>Lbs.</i>	<i>oz.</i>	<i>Lbs.</i>	<i>oz.</i>	<i>Lbs.</i>
Sussex.....	314	4	304	3	4086
Hampshire.....	294	0	259	12	3911
More food required by Sussex sheep.	20	4	44	7	145

From this table it will be seen that the Sussex sheep, to produce 100 lbs. increase of animal, required $20\frac{1}{4}$ lbs. more oilcake, $44\frac{1}{2}$ lbs. more clover, and 145 lbs. more ruta bagas, than the Hampshires. The average weight of wool per head was, from the Hampshires, 6 lbs. 4 oz. ; and from the Sussex, 5 lbs. 19 oz. The proportion of wool to 100 lbs. live weight of animal was, for the Hampshires, $3\frac{3}{4}$ lbs. ; and for the Sussex, $4\frac{1}{2}$ lbs. The average weight per head of the Hampshires when fat, including wool, was 183 lbs. ; and that of the Sussex, 141 lbs. The average weight of carcass of the Hampshires was 101 lbs. 14 oz. ; of the Sussex, 76 lbs. 13 oz. The average weight of offal per head was, from the Hampshires, 12 lbs. 4 oz. ; from the Sussex, 9 lbs. 10 oz. The exact age of the sheep is not stated ; but as they are called lambs, we presume when killed they were about fifteen months old.

Of the money results of the experiments we need not speak ; it depends on the price of oilcake and the cost of raising clover and ruta bagas. In England, however, it is considered profitable, when fattening sheep on ruta bagas as the principal food, to give them oilcake and clover chaff, providing the increased value of the sheep is sufficient to pay for the additional food ; the value of the manure, which is much improved by the oilcake, more than paying for the ruta bagas and cost of attendance.

Of the value of these two breeds of sheep our readers will be able to draw their own conclusions from this summary of results given. It is evident that the consumption of food per 100 lbs. live weight of animal is nearly identical in both cases, and that the Hampshire will give a greater increase for this food than the Sussex sheep. The Sussex, however, produced the most wool, which sold for one cent per pound more than the Hampshire. Our own conclusions from these experiments are, that the Hampshires will be found more profitable for this country than the Sussex.

Mr. LAWES is now trying experiments between the Cotswold and New Oxford, and the Lincolnshire and Leicestershire breeds. He informs us in a private letter, that so far as increase of animal from a given amount of food is concerned, the Cotswold are superior to the New Oxford and both the Hampshire and Sussex downs. In an experiment on Hampshire downs, on the nutritive value of different foods, Mr. LAWES found that, sheep weighing $121\frac{1}{2}$ lbs. at the commencement of the experiment, consumed 7 lbs. of oilcake and 22 lbs. of clover hay per head per week, and increased $30\frac{1}{2}$ lbs. in 19 weeks, or 1 lb. 9 $\frac{1}{2}$ oz. per head per week. The same kind of sheep by the side of these, fed with linseed and clover hay, and weighing when put up exactly the same as the others, consumed 7 lbs. of linseed and 20 lbs. of clover hay, and increased in 19 weeks $28\frac{1}{2}$ lbs., or $1\frac{1}{2}$ lbs. per head per week.

The oilcake used in all these experiments was American, which contains more nitrogen, and sells for a higher price, (at present it is worth \$40 per ton,) than the English. The English contains more oil than the American. This, however, does not materially increase its value ; for it will be seen that, *weight for weight*, the cake which is left after the oil is pressed out of the linseed, is more fattening than the linseed itself. This, so far as we have seen, has been the result of every trustworthy experiment on the relative value of oilcake and linseed as food for animals. It would indicate that oil is not of such a fattening nature as has been generally supposed.

Condensed Correspondence.

SALT vs. FIRE.—In the November number of the *Farmer* for last year, I noticed a communication relative to the burning of a barn, as was supposed, by spontaneous combustion, produced by the grain being drawn in too damp. Your answer directed that the hay and grain should be thoroughly dried before storing. This is good advice when it can be adopted without the hazard of grown wheat, and bleached and half rotten hay; but there are times (instance the last two seasons) when this seems impossible. Now, permit me, with due deference to your superior knowledge and ability, to suggest a preventive to you and the readers of the *Farmer*, which I have adopted with much confidence for some years past. I refer to salting both hay and grain when drawn in. This to some extent has been practiced among farmers in these parts, but perhaps by few, if any, with a view to this idea. And it is doubtless attended with other advantages. It is a well known principle of chemistry, that substances in passing from a denser to a rarer state, produce cold, as salt, snow, &c.; and this, so far as I know, seems to be somewhat peculiar to salt. Who is not acquainted with the sensation of cold felt upon immersing the hand in strong brine. Numerous illustrative examples might be given, but let this one suffice. SOUTH BRISTOL.

SHEEP FRAUDS.—We have seen statements published in agricultural journals, by Vermont wool-growers, bragging of their sheep and fine wool, and challenging the world to produce their equal. Such assertions are a touch beyond the exaggerating advertisements of quack doctors, puffing their nostrums. These nauseous assertions, like bitter pills, require oiling, as they do their sheep, before the farmers of the west can be made to swallow any more of them. Now, if their wool is as good as they have represented it to be, will you, Messrs. Editors, or some of your Vermont subscribers, be so kind as to tell us, through the *Farmer*, why it is that the greater part of last year's clip of Vermont wool was still in the hands of the growers, unsold, on the first of March last? and why it is that the manufacturers purchase up all the wool about the country at shearing time, and pass by Vermont wool as unworthy of their notice? The dear bought experience the farmers of the west have had for the past two years, in purchasing eastern sheep at prices much above their value, compels us to state that many of their sheep, like their wool, have proved very different from what they were represented to be. The sheep peddlars cut the eye teeth of many of our farmers, which has created a great distrust in anything that writers or peddlars may say respecting their sheep, and now we are all on the look-out for sharpers. A.—*Ann Arbor, Mich.*

RUTA BAGA AND MANGEL WURZEL.—I have been in the habit of raising about half an acre of ruta baga for several years, and think them indispensable for my flock of breeding sheep in the spring. I usually sow them the last week in June, in rows about thirty inches apart, and hoe them out ten inches in the rows. I have never used superphosphate of lime, but if sufficient to manure an acre can be made by the farmer himself for four dollars, as you say in the March number, I should think if it does as much good as you say it does for root crops, that it is much cheaper than barn-yard manure. I usually get about three hundred bushels of ruta baga from the half acre. I have never grown mangel wurzel, but as you so strongly recommend them in the March number, I mean to plant a quarter of an acre this year, by way of experiment. You say that "though this root contains about 87 per cent. of water, yet more nutritive matter can be obtained per acre from this crop than any other." I certainly should not have thought that roots contained 87 lbs. of water in every 100; but you say that ruta baga contain even more water than mangel wurzel, and that even green clover contains 80 per cent. of water.

I was not a little surprised at the amount of water a crop of clover exhales during its growth, from an acre of land—no less than 430 tons, or 8600 lbs., per day. Truly, plants require, or at least take their food in a very diluted state. And it would seem, as you say, that this amount of water, impregnated as it is with carbonic acid and ammonia, is capable of taking up every element that enters into the composition of the plant, even the most insoluble. A CONSTANT READER.—*Dutchess Co., N. Y.*

GROWING MELONS.—Perhaps it would interest some of you readers to know of a method of cultivating melons which I have practiced very successfully for the past three or four years. For some reason they do not ordinarily ripen well in this region when planted, as on Long Island or in New Jersey, in the open air. I have first dug holes two and a half feet deep and three or four in diameter; into this, the last of April, I have thrown stable manure, such as is used for hot-beds, three or four wheel-barrowfuls. On the top of this I place a box, shaped like the box of a hot-bed, but only large enough to require four panes of 8 by 10 glass, and in the box I place six or eight inches of sand, with ashes and charcoal, and hoe the dirt around the box in the form of a neat mound. After a few days I plant my melon seeds, enough to give me a selection of the best plants, leaving but three in a hill when fully grown. In the sides of the box may be sown tomato seed, as in a hot-bed. The result has been, that my melons and tomatoes have ripened two or three weeks earlier than they would otherwise have done, and in great profusion. F.—*Homer, N. Y.*

SWEET POTATOES.—I have been raising sweet potatoes for the last seven or eight years, and for the most of that time have experienced much difficulty and loss in wintering the seed for the next year's crop; but I now feel much gratified in being able to inform you and the public, that all the extra labor which I believe to be, generally thought necessary to preserve the seed over winter, is entirely unnecessary and worse than useless, of which I have been growing suspicious for several years past. Last fall I adopted the following mode, with complete success and entire satisfaction:

I dug my potatoes during a spell of nice Indian Summer, about the first week in October. They were handled carefully, taking care to bruise them or fracture the skin as little as possible, (which I think as necessary as in the management of keeping apples,) and spread on a clean sod and exposed to the sun for from a week to ten days. I then carefully gathered twenty-six bushels of them in a basket, carried them up stairs, laid them away in barrels and boxes, and covered them up with old carpets, bags, or anything to keep the air from them. When the winter began to set in cold, I collected them around the stove-pipe and chimney, and covered them all over in a body with boards and other covering extending down to the floor, thus husbanding all the heat that might arise through the course of the day from the pipe and through the floor, which were considerable, as they were located over a cook stove in which there was generally fire from five o'clock in the morning until nine or ten at night. During some of those coldest days and nights, (of which some were extremely cold—from 12 to 15 deg. below zero,) the heat was so great on those boxes and barrels nearest the pipe, say within six inches, that I could scarcely bear to hold my hand on them at that point. There were two barrels, furthest from the fire, that were touched with the frost a little, which I overhauled in February. I believe I can safely say the whole loss on the twenty-six bushels, including those that were frost-bitten and a few small ones dried up by the excessive heat, did not exceed five pecks. I now have thirteen bushels of them in hot-beds, and offer the plants at fifty cents per hundred, or four dollars per thousand.

I discover that by putting them in large quantities together when fresh dug, they will ferment, or go through a sweating process, which is very injurious, in which I believe the milk is more or less converted into water, and the saccharine principle more or less destroyed, thereby unfitting them either for the table or to keep. It is the opinion of many that they are fit to eat only while fresh—that they get to be out of season, &c.; but this is a mistake. On the other hand, the longer they are kept, the sweeter and more delicately flavored they become, as I argue, from the greater concentration of the saccharine matter as the water evaporates.

There is another false opinion more or less in circulation, in regard to eastern and western grown potatoes, which is, that the eastern grown are sweeter and better than the western grown tubers. This idea was strongly advanced to me one year ago last fall, in Buffalo. On the contrary, I believe what little difference there may be, if any, is in favor of the western grown; in defence of which position, let me advance a short statement, which is this: The Irish potato, as it is called, which is raised in this country, is more delicately flavored than those of the eastern States. This opinion I believe is universally admitted here. I think the cause is in the soil—this being light and loamy, and that heavy clay and gravel;—the one being in a state of nature—rich, fertile, and fat; the other, barren, sterile, and poor in comparison. This I have tried, in the article of beets, in my garden, which in the natural state is a stiff yellow clay. At the first improvement of it, I hauled upon it enough of wetfish prairie soil (I can not call it muck) to make two or three beds. The following season was quite a dry one, and the beets which we grew in the clay soil were so bitter we could scarcely eat them, while those of the same seed and variety which grew in the prairie soil,

were mild and sweet. I conclude from analogy, that the western grown sweet potatoes are likely to be the sweetest and best.

Now, a word as to what may be the cause of this false opinion expressed in Buffalo, concerning western grown potatoes. May it not be from the fact that in the west there are a great many varieties of them grown, and many of them of inferior quality, each variety being different almost as apples. Sweet potato amateurs have represented to me that the very best varieties are the *Yellow Spanish* and the *Red Spanish*, and that there is little difference between them, some choosing the one and some the other.

Last season I planted from the 10th of June to the 10th of July; the last planted were of course not very large, but paid very well. I believe there are more failures from having the ground too rich than too poor. If manure is thought to be necessary, spread on and plow it in deep, then harrow well, ridge up three furrows together three and a half feet apart, and set the plants from a foot to eighteen inches apart. Keep them clean, the vines loose from the ground in all other places except at the original root, and the ground well ridged up, and you may expect five bushels to the hundred sprouts, if planted by the 10th of June. CYRUS MOORE.—*Port Clinton, Mich.*

GAPES IN CHICKENS.—As my husband is a subscriber and constant reader of your valuable paper, you will, I hope, pardon the liberty I take in addressing you a short article on the subject of "Gapes in Chickens," which, if you should consider worthy a place in your pages, you are welcome to lay before your numerous readers, for the consideration of those who have been learning by dear experience (as I think I have learned) the nature of this troublesome disease. I have been induced to write this from having seen no answer to the numerous inquiries on this subject, that were satisfactory to my mind. One writer attributes gapes to giving chickens wet food; another, to sour food; another to light bread; &c. These theories may all be correct; but from several years' experience in the rearing of chickens, I am persuaded that the food has but little to do with preventing, producing, or curing gapes, since the same results have been produced from giving a dozen different kinds of food prepared in nearly as many different ways.

As many persons who raise fowls appear entirely ignorant of the nature of this disease, I will state plainly my views. The constant gaping is the consequence of an effort on the part of the chicken to expel a knot of small worms, which I have always found in the windpipe, (and not in the gullet, or meat-pipe, as many suppose,) at its lower extremity, where it joins the lungs. Their location appears very evident from the fact that they prevent respiration, and hence the effort to expel them.

The Cause.—I have never yet been able to detect any other cause for this disease than *cold*, as the chicks are always affected during or soon after cold, wet weather, and never in good weather.

The Cure.—I have tried all the prescriptions that have been recommended by the most learned "doctors" who have written on this subject, through the agricultural press—black and Cayenne pepper, Jerusalem oak, spirits turpentine, and a host of other nostrums, that have had no other effect than to assist the little sufferers off. I have also tried to extract the worms with a wire; but this I consider very unsafe, as it kills as many as it cures. I have also tried a feather, with no better success; as one stiff enough to extract the worms is very apt to destroy the chicken. My present remedy, however, has never failed in a single instance, if taken in time. It is this: I procure a spear of blue-grass, and after stripping off the seeds, I twist it in my fingers until I get the fibrous branches closely entwined around the main stem; then pulling out the tongue of the chicken until the mouth of the windpipe is presented, I insert the spear of grass, and turning it around several times, until it reaches the lower extremity of the windpipe, I withdraw it with the worms attached. If, however, the worms do not appear to be all extracted, I have a cup of water at hand into which I plunge the beak of the chicken, which causes it to sneeze up the remaining worms that have been loosened by the grass. It is sometimes necessary to insert the grass more than once, especially with "young practitioners." Many persons whom I have instructed how to cure chickens of gapes, have killed every one they attempted to cure; but upon investigation, I have found that they put the grass down the *throat* instead of the *windpipe*. Great care must be taken in this matter.

To prevent Gapes, I have only to observe a little care in cold, damp weather, to keep my young chickens comfortably housed. An eye should also be kept to avoid those causes in the management of fowls which produce degeneracy, since healthy fowls are not liable to disease.

I may not be correct in my theory; if so, I hope to be corrected. One thing, however, is certain; in my *practical treatment* of the disease, I have the satisfaction of knowing that I never lose a single chicken. A. A. J. JONES.—*Bellefonte Landing, Ky.*

HOMES FOR THE POOR.

BY L. T. C. E., OF ONONDAGA HILL, N. Y.

PERMIT me, through your pages, to call the attention of wealthy and philanthropic agriculturists to the importance of providing homes for the poor, particularly that class employed as farm laborers. A large portion of this class of our inhabitants have never had, and never will have without a little assistance, a home of their own; and many of them depend upon shifting their quarters as regularly as the spring returns. The idea of ever owning a home seems to them an impossibility; yet there are few families whose *unnecessary* expenses, in the course of four or five years, do not amount to more than sufficient to purchase a home that would make them as comfortable as the owner of thousands. A man who never expects to earn faster than he spends, will have but little calculation or economy; hence it is that those persons who live in daily want of the necessaries of life, usually spend more time and money at parades, exhibitions, and for all sorts of sight-seeing, than those who have comfortable fortunes. This miserable habit of continually shifting quarters doubtless begets those thriftless, untidy, and not infrequently dishonest habits, which are almost invariably found connected with extreme poverty. But instead of wondering at these traits of character, when connected with physical and intellectual destitution, we should wonder at the exception. He who has nothing of his own, will not be likely to be very conscientious with regard to what belongs to another; and it is useless to expect a man to have the same care for neatness or economy while residing on the premises of some wealthy landlord—which he is to occupy but for a year or two, or perhaps at the option or caprice of the owner—as he would have if the premises were his own; or that he will have the same inducement for becoming an honest, industrious, and reputable citizen, that he would have if he expected to become a permanent resident. Give a man a snug little cottage, with but an acre of ground well stored with fruit, with his cow, pig, and poultry, and he will have no more disposition to encroach upon his neighbors than if he were worth ten times that amount;—he has *his* rights; he will consequently respect the rights of others. And if he were obliged to pay his own school bills and his share of taxes, however small they might be, his children would be more likely to be sent to school, and kept from breaking windows and committing other depredations upon public property. I do not make this suggestion as grudging any amount that may be expended for the real benefit of the poor, but because whatever is free is generally considered of little value.

But the greatest evil resulting from this unsettled mode of living, is the influence it has in forming the character and habits of children. They are naturally fond of novelty, and moving into a new neighborhood soon becomes with them a very important desideratum; they have never had a home long enough to become attached to one; they have nothing to leave or lose; and every change, even for the worse, will at least gratify their curiosity. If they are naturally active and intelligent, they early acquire an uneasy, roving disposition, which unfits them for perseverance in any pursuit; they get an idea that "the world owes them a living," which they intend to have for the least labor. Some of them will no doubt make very expert gamblers, jugglers, mesmerizers, spirit-knockers, and not a few will become inebriates and felons. If they are dull and lazy, they become tavern-loungers and vagrants, till necessity forces them to seek an asylum in a poor-house; and a majority of the persons who have once resorted to a poor-house for relief, imbibe a fondness for that mode of life, (which requires little exertion and no calculation or forethought,) and become attached to the society which such an asylum always affords, and ready on the slightest pretence to seek admission again within its walls. I have known veteran paupers who boasted of having been in every, or nearly every, poor-house in the State. Their children in turn become paupers; and in this way pauperism will continue to increase *ad infinitum*.

The expense of supporting the poor is every year becoming more and more expensive, with the discouraging and mortifying assurance that the very method taken to relieve them is augmenting their numbers. Now, for economy's sake, if not for the sake of humanity, let as many as possible be provided with homes. No sober, industrious man, who owns the smallest place that could be called a home, ever need fear a poor-house. In case of sickness or casualty, neighbors would render every needful assistance. If every able farmer would assist *but one* laborer in procuring a home, and occasionally give him a little encouragement and advice, he would render him a more important service than if he were to supply his family with bread; besides, it would furnish an example for others of the same class, which they would soon become ashamed not to imitate. An acre of ground could be purchased and a comfortable tenement erected, in almost any agricultural district, for two hundred dollars; and any healthy, industrious laborer could easily pay for it in four annual installments; for an acre of ground, if skillfully cultivated, would in the mean time contribute largely to the support of his family, and furnish those who were not old enough to get work abroad with something to do towards earning their own living. Improving and embellishing a little homestead would also afford the laborer both profit and pleasure during his spare time, which he would otherwise be very likely to spend in the nearest bar-room. What a delightful change would soon be effected in country scenery, if every laborer were provided with a home of his own. Instead of old, dilapidated dwellings and temporary shanties, scarcely affording a shelter, we should see neat little cottages and gardens, snugly ensconced in their groves of fruit trees, sprinkled over the country, forming no unpleasing contrast with the homes of the more opulent.

I believe all children are by nature agriculturists; I never knew *one* who was not fond of cultivating fruit or flowers. And what man or woman is there, who was so fortunate as to have been brought up on an acre of ground, who does not remember the interest they have taken during childhood in some particular tree or flower, and the assiduity with which they labored early and late, in hoeing, weeding, and watering their plants, till they not unfrequently killed the poor things with kindness. I once knew a poor little invalid who was confined to her room, and mostly to her bed, for nearly two years before her death, who had a tin pan filled with earth, kept on a stand at the head of her bed, which she called her garden. This she divided into compartments of various sizes with a little paling made of bits of shingle, and in these she planted seeds producing plants of the smallest growth. These served to employ more or less of her time every day, till they began to droop, or became too large for their small enclosures; then she would have a return of spring — clear up her garden, move her fences, cultivate her ground, and plant again, with as much variation as possible from her former plan, and watch and tend with as much interest as before. Of all other diversions invented to amuse her and relieve the tediousness of her confinement, she would after a time become weary; this alone afforded her a permanent source of enjoyment. I am confident that if children were provided with comfortable homes, with the privilege of cultivating fruits, vegetables, and flowers, (of which they should not only be partakers, but sharers in the profits), it would prove a far more efficacious as well as a cheaper antidote for juvenile delinquences and vagrancy, than the best disciplined penitentiary that ever existed.

Building poor-houses, and giving old clothes and broken victuals, is poor charity; it debases the recipient, affords only temporary relief, and will never lessen pauperism. The most effectual and only permanent method of helping the poor, consists in helping them to help themselves.

SOILING CATTLE IN SUMMER.

By soiling, is meant the practice very prevalent in different parts of Europe of keeping cattle in the barn-yard or in stables during summer, and feeding them with green crops. The high price of labor in this country, compared with Europe, is a decided objection to the profitable adoption of the system; yet it is worthy of trial, and we have little doubt that part soiling may be practiced with advantage.

Italian rye grass, lucerne, sainfoin, vetches, and clover, are grown to a great extent in England for the purposes of soiling. Especially are vetches recommended as food for horses, and good farmers usually grow sufficient to supply their teams during the whole summer, so that the horses are never turned out to pasture. We believe several Scotch and English farmers have tried to grow them for this purpose in this country, but have not succeeded, the great heat of the summer being unfavorable. Italian rye grass is now being sown for this purpose, and we think will be found valuable. But clover!—we can beat the world on clover,—the soil and climate of America seems to be peculiarly adapted to the growth of this most nutritious and valuable of all green crops, and we are surprised that it is not more generally grown for soiling purposes. There appears to be little question but what an acre of land mown twice or thrice during the summer, will yield double the amount of food to what it would if pastured and kept bare, with nothing to screen the roots from the scorching hot sun. And doubtless the roots of the plant have a corresponding proportion to the amount of produce yielded in leaves, stems, &c.; so that we have not only an increase of food for the cattle, but a greater amount of vegetable matter left in the soil as food for the following crops. We have always been in the habit of giving our horses green clover in the stable during “nooning,” and would earnestly recommend the practice as one that will pay. Whether it will pay to keep the horses up altogether and feed them with green clover during summer, we can not say, but are inclined to think it would.

For oxen and milch cows we know of nothing so well adapted to the climate, and of which you can obtain so large an acreage product, as green corn—directions for sowing which we gave last month, page 160. If you have not yet sown any, it is not too late, and we will warrant it comes in useful. We never knew any one have more than he knew what to do with. It is seldom sown thick enough—four bushels is in our opinion none too much seed per acre, if sown broadcast. It is, too, advisable to sow the corn at different times in the spring, say at intervals of two weeks, so that you will have some just in the right stage to cut during the whole summer; whereas, if you sow the whole at once, you have either to cut some too green or let some get too ripe, and the stalks become pithy and innutritious, and are not relished by the cattle. We do not recommend the practice of growing corn and making it into fodder for winter use. It is a troublesome business curing it properly, and we prefer to get grain as well as stalks in the ordinary way; for though there is probably a destruction of nitrogen, and much of the soluble saccharine matter is converted into woody fibre, in the process of maturing the seed, yet there is doubtless more nutritious matter in *grain* and stalks, than there would have been had it been cut and converted into fodder before the seed was formed.

There is much difference of opinion as to the best method of feeding green corn stalks to milch cows—some good farmers taking them into the pasture and spreading them on the ground, while others object to this plan, saying it makes the cattle restless, that they stand longing at the feeding spot and are always expecting more stalks, and do not disperse and fill themselves with grass. If, however, they are fed regularly every day, and their importunity for more is never complied with, they soon learn that they had better be at other business. Others feed them in the barn-yard, and thus obtain a considerable quantity of manure which would be wasted in the field. The cattle should not be fed with the stalks in too large quantities at a time, or they will be surfeited.

HUNGARIAN CATTLE.

SOME time since, we spent an hour very pleasantly at the residence of ROSWELL L. COLT, of Patterson, New Jersey. His grounds are well laid out, and furnished with rare and fine trees. But what we intend now to call attention to, is his fine Hungarian Cattle, a bull and a cow, which he has named *Kossuth* and *Briska*. They were exhibited by Mr. C. at the late State Fair in this city, where the drawing from which our

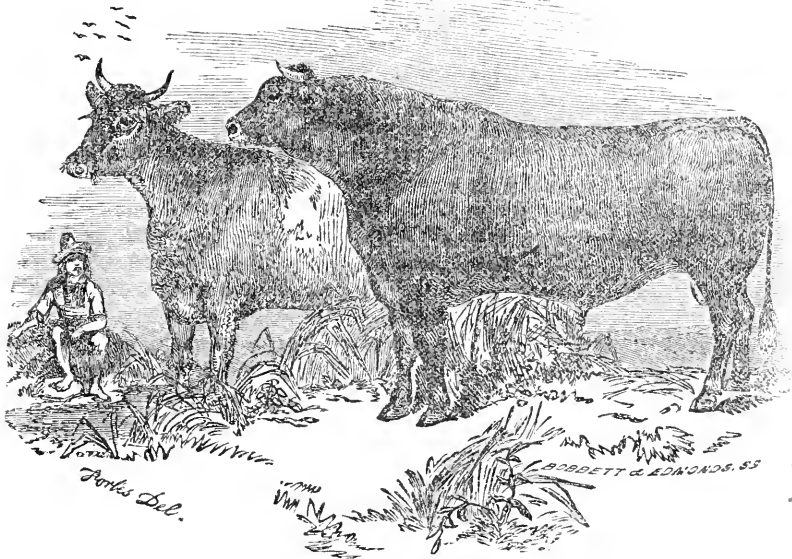

HUNGARIAN CATTLE, OWNED BY ROSWELL L. COLT, OF PATTERSON, N. J.

engraving is made was taken. The committee make the following remarks in their report on these cattle: "The committee consider them as an experiment in this country. Their usefulness has yet to be tested. We highly commend the enterprize that sent them here. We doubt, however, whether as much improvement to our American herds will be secured, as with the British stock which has been generally adopted. We recommend a Diploma and the thanks of the Society to Mr. COLT, for his public spirit in sending them to the exhibition."

CAST IRON ENAMELLED STABLE-FITTINGS.—MESSRS. COTTAM & HALLEM, whose splendid castings occupied a prominent position in the crystal palace, exhibited a very beautiful set of stable-fittings—rack, manger, and water-trough, enamelled. They possess the advantages of beauty, durability, and cleanliness, and are certainly well worthy of attention. Wooden fittings are objectionable in many respects—horses gnaw them if they happen to be kept idle in the stable; and if not looked to very carefully, in warm weather especially, they become sour, and prevent horses from feeding well.

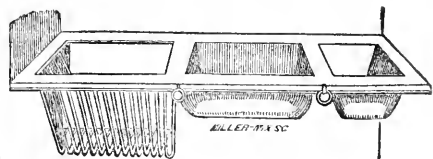

STABLE-FITTINGS.

Horticultural Department.

CONDUCTED BY P. BARRY.

THE propagation and culture of fruit trees in the nursery, and the production of fruits in the garden and orchard, at the present time occupy the attention of a very large number of persons in the United States, and constitute a very important item in the general industry. To the majority of those embarking in it the business is entirely new, and they have everything respecting it to learn. The more experienced, even, have much more to learn than they imagine. It is by no means a simple thing—the work or study of a few weeks or months—that will make a nurseryman, or a fruit-grower, even. We not unfrequently hear people say they would like to send their sons to a nursery for a few months, to learn the business; and a man embarking largely in fruit culture, will sit down and address a dozen inquiries to a horticultural journal, expecting replies that will at once enable him to prosecute the matter successfully. Now, we wish to draw attention to these errors; the sooner people are undeceived in these matters, the better it will be for themselves and the community. We are an apt people, to be sure; still we have to learn our alphabet before we read, and a certain length of time is necessary to learn the simplest mechanical art. Agriculture and horticulture present a much wider field for study, and a much more embarrassing one, than any mechanic art; and yet, strange enough, few people are willing to believe that they can not at once leave the work-shop or the counting-room, and become successful farmers, gardeners, or nurserymen. How many are every year awakened from this delusion, by dear bought experience. A few succeed: they are those who appreciate their want of knowledge, and go to work as zealous and earnest students,—like a man who finds himself in a foreign country, ignorant of the language spoken, and conscious that he can not prosecute his travels with either pleasure or profit, until he has learned it. Such is exactly the position of the man who becomes a tiller of the soil, a grower of wheat or corn, a breeder of stock, a propagator of trees or plants, without previous study and preparation. Nature speaks to him in an unknown tongue; he is continually mistaking one sound for another; blunder after blunder confuse him; and he soon finds he must either leave her and return home to his old pursuit, or at once bend himself down, with dictionary, grammar, and “first lessons,” to a study of her language.

“Oh, you are exaggerating!” says a friend. “What mystery is there in farming? Who is so stupid as not to know how to buy himself a farm; a few horses, cows, and implements; plow the land, scatter the seed, and harvest the crops? What simple operations!” Pardon us, dear friend, for suggesting that you ought to have some knowledge of the qualities of soils; or you may buy just such land as some one may be glad to get rid of, but will not suit your purposes. You ought to know something of animals; or you will certainly stock your farm with a collection in which every fault known will be represented. You ought to know something of the feeding of farm stock, and their diseases; or half your animals will die before you are aware of their sickness. You ought to know something of the comparative value of the different varieties of grains and vegetables, that you may plant that which will best suit your market and your soils. There are a thousand other matters you ought to know of, and that you must learn by experience before farming will be profitable. So in gardening;—you will find it unpleasant not to know either how or what to plant. And here the operations are more difficult, because much more numerous, and more minute, and less generally understood. The propagation and culture of trees and plants is a great study—not to be learned in a few months. After some sixteen years’ daily and hourly experi-

ence, close study, and observation, with opportunities as good as most people have enjoyed, we feel but like an apprentice who had served his first year, and began to know how to handle his tools, and understand their names and uses.

We would have people look less lightly on these pursuits. Young men especially, who aim at acquiring a respectable position in them, should go to work in earnest—begin at the beginning, and discard the fallacious idea that a few months can be any sort of preparation to enter upon this practice successfully. Those who aim at being nurserymen, should go and serve as apprentices for at least three or four years in the best establishments, where they may get a thorough training. To be able merely to put a tree in the ground, or to set a graft or bud, is but a small part of the trade. The time is fast approaching when such acquirements will not do; they will not be sufficient to contend with greater skill, nor will they inspire the community with that confidence without which success can not be attained. A sentiment is fast growing up against quacks, or half-way workmen in any profession, and all such will find themselves run off the track. Reading, study, and observation, continual, are necessary in conjunction with every-day practice.

The growing season is the time to acquire information; everything is active, and yielding to surrounding influences. The effects of soils and manures, dryness and moisture; the attacks of insects and diseases; the habits of growth and bearing of trees; the ripening of fruits; the advantages of different modes of propagation, pruning, and training; and all the various treatment that trees and plants undergo during summer, should be closely watched, and every result be seized upon and turned to account, for the guidance of the future. This applies to every department of cultivation, whether it be the farm, the orchard, the fruit garden, or the flower garden. Our lady friends who are embarking in the culture of flowers for their recreation and amusement, and for the embellishment of their homes, must not rest satisfied with admiration of their beautiful colors or foliage; they must study their habits, observe what soil and treatment suits them best, learn their geography, history, origin, &c., and they will greatly multiply the pleasures and benefits of floriculture.

We hear too many complaints of "barbarous Greek and Latin names;" people want everything easy and ready made. A little study and practice will make the hardest names easy and familiar. The world is wide; nations are various, and speak different languages; the names of people of one country are strange and hard to those of another; but we can not translate them—we must take them as they are. And so with the names of plants, or fruits, or flowers, named by foreigners,—we must learn to pronounce them as we learn other things more difficult.

RUSTIC WORK IN GARDENS.

WE observe about the country an increased display of huge pieces of carpentry, painted white as snow, and placed in the most conspicuous part of the garden, intended as trellises or supports for climbing plants. Indeed, they are becoming quite *fashionable*—large numbers have been on sale during the spring, in Rochester, and they have become a standing article of commerce. We rejoice at the growing taste and the increased attention to gardening, that make trellises for climbing plants in demand, but we must say we would greatly prefer something more simple, rustic, and natural,—something that would look as though it was merely intended to support a climbing plant, instead of being itself the principal ornament. To our taste, a young cedar tree stripped of the foliage, leaving the bark and branches on, is a much more *beautiful* support for a climbing rose, or honeysuckle, or anything of that kind, than one of these elaborate productions of the carpenter.

When we pass a garden, and see a great painted pyramid of posts and lattice work, with a little, starved, neglected plant somewhere in the grass at its base, the impression is forced upon us, right or wrong, that the proprietor is less a person of true taste than a lover of show — one who has a garden because it is fashionable, more than because it is beautiful. We think better, we confess, of the taste of the poor girl who has the walls of her father's little cabin covered with "morning-glories" climbing on common strings, than we do of his. We are very far from being opposed to garden embellishments of an architectural kind, but we would insist upon their being in good keeping with the garden; we can not commend the taste that expends ten dollars cheerfully for an "ornament," and one dollar grudgingly for trees or plants. —

Great naked pyramids of painted boards and empty iron vases on a naked lawn, are by no means indications of true taste. A garden is no garden, whatever else it may contain, without a profusion of trees, shrubs, and flowers.

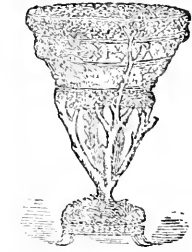

We would be glad to see rustic work more generally introduced into gardens. They are cheap, simple, and appropriate, indicative of taste and ingenuity more than wealth or fashion, and more in harmony with the plain and simple character of our village and country gardens, than those of an expensive or elaborate kind. A rustic basket, a lawn filled with verbenas, petunias, or any such long-blooming plants, is a very pretty object. Above we give the figure of one raised on a rustic pedestal. We also annex the figure of a pendant one, which has a very agreeable effect suspended in a room, hall, verandah, or in a green-house. Some very pretty specimens were in Floral Hall at the last New York State Fair, made by Mr. ADAM KACHLER, of Le Roy. A very pretty pendant one was made of a large oak knot, hollowed out. Others were made of grape vine stems, rough bark, acorns, and fir cones. We shall hereafter give some illustrations of Mr. KACHLER's work.

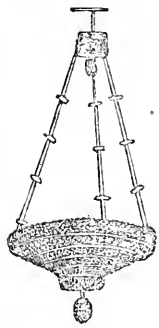

BROWN'S PATENT FUMIGATOR. — This is an excellent English contrivance for fumigating trees and plants, to destroy insects. Tobacco is placed in the magazine at top, and

lighted in the same manner as an ordinary smoking-pipe. A draught of air is produced for its combustion by the revolutions of a fan, which draws the smoke in at one part of the cylinder and drives it forcibly out at another in a cool state. It is used in fumigating orchards, fields of turnips, &c., as well as green-houses. It may also be used in cellars, out-houses, &c., wherever insects are troublesome. It is a simple, convenient article, easily used by any one. It is highly recommended by all who have used it

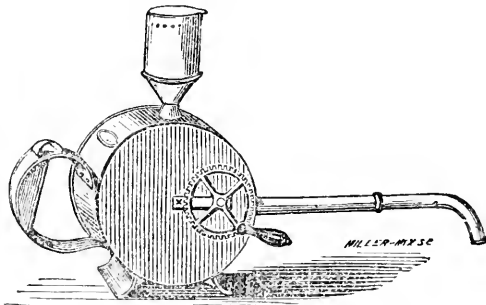

BROWN'S PATENT FUMIGATOR.

in England and this country, and must become of very general utility. It may be had in Boston or New York. The price, we believe, is \$5.

THE FORSYTHIA VIRIDISSIMA. — This fine shrub, one of the best of FORTUNE'S collection in China, is now, May 10th, loaded with its gay yellow blossoms. We shall give a description of it next month.

HINTS FOR JUNE.

DURING the whole of April, and the early part of May, up to the 8th, the weather continued cold and backward, but without frost. Hyacinths in the garden were not in full bloom till the 10th of May; about that time we had a few warm days, the thermometer rising above 80 deg. in the shade. Vegetation pushed with uncommon rapidity, so that on the 12th, trees were quite green and cherries in blossom. The fruit crop here promises well. The transplanting season, though unpleasant throughout, has been long, and gave ample opportunity to all who had labor of that kind to perform.

An immense number of trees have been planted the last fall and the past spring, and we trust they will not be forgotten. To secure a good growth, they must receive constant attention. The ground must be kept clean by frequent dressings, unless mulching has been applied, which is very advantageous in all cases. Sawdust, spent tan, half decayed manure or leaves, are all good mulching material. When the heads have not been properly reduced by pruning at the time of planting, and the trees do not push freely, but seem to flag and linger from debility, the branches should yet be shortened, to reduce the quantity of leaves. People sometimes think it a great hardship to spoil a symmetrical, well branched tree, by pruning; but it is always better to do this than lose it, or stunt its growth during the whole season.

Trees intended to be trained in particular forms should be watched, and all badly placed or superfluous branches pinched off; such as are pushing with too much vigor for their position, should be checked. This is the time to mould the trees into the desired form, and to obviate heavy pruning next winter. Yearling trees that have been cut back to produce pyramids, will now show whether the pruning has been properly done. If not cut back low enough, the top shoots, if left, will rob those below, and the shape will be spoiled. In such cases it will be necessary to pinch the top shoots, to check them and encourage those below; and in some cases it may even be necessary to cut lower down. If they have been cut too low, several shoots of equal vigor will be produced; and in order to give the leader due prominence, the others should be pinched to check them. The same principles will apply to older trees.

Trees budded last autumn, or grafted this spring, will require to have the suckers that always start freely below the bud or graft, promptly removed; in some cases they must be gone over two or three times. The growing bud or graft in many cases will require to be carefully tied up to the stock, or to a stake, to prevent breaking by the wind.

Strawberry beds must be kept clean of weeds, and the runners shortened, to turn the whole strength of the plant to the benefit of the fruit. While the fruit is swelling, a few waterings with liquid manure, and in case of dry weather, an abundance of water, will greatly improve the crop. As the fruit ripens, a little short straw or hay should be spread along the rows, to keep the fruit clean.

Flower Garden, &c.—Tie up neatly all tall-growing herbaceous plants, whose stems are easily broken or blown over. Plant out dahlias any time during the month;—we prefer the last half of June for the finest autumn display. Perpetual roses, and all the bedding plants to be had in pots, may be turned out any time during the month. Among the latter we will mention, as being particularly desirable, the scarlet geraniums, salvias, eupheas, heliotropes, lantanas, plumbagos, veronicas, and zauschneria, besides the indispensable verbenas and petunias. We ought also to add *phloxes*—the new varieties are very beautiful; and if small plants are turned out now, they will give a fine bloom in the autumn. *Annuals* will be ready for transplanting. Do this on a moist, cloudy day, or before a shower, if possible. The dwarf, slender-growing sorts, are best grown in masses, like the verbenas, &c. Weeds must be kept down in all parts of the garden, grass kept closely cut, and gravel walks clean and level by frequent raking and rolling.

Grass edging must be kept cut to prevent them spreading; as little of the raw edge as possible should appear.

Vegetable Garden.—Keep up a constant succession by frequent sowings, of such things as green peas, radishes, and salads, not forgetting to make ample provision for the main autumn crop of all the leading articles. Use liquid manure and water freely in warm, dry weather, or your vegetables will not be fit for the table.

THE EASTER BEURRE PEAR.

This pear has for several years been spoken of, and propagated and planted to some extent in this country, yet it has not attained any considerable popularity. The reason, we apprehend, is, that its merits are very little known. We are glad to be able to speak of it after repeated and pretty extensive trials.

The *Easter Beurre*, so far, holds the same rank with us among pears as the *Northern Spy* among apples—that is, the best long-keeping table variety. We have them now,

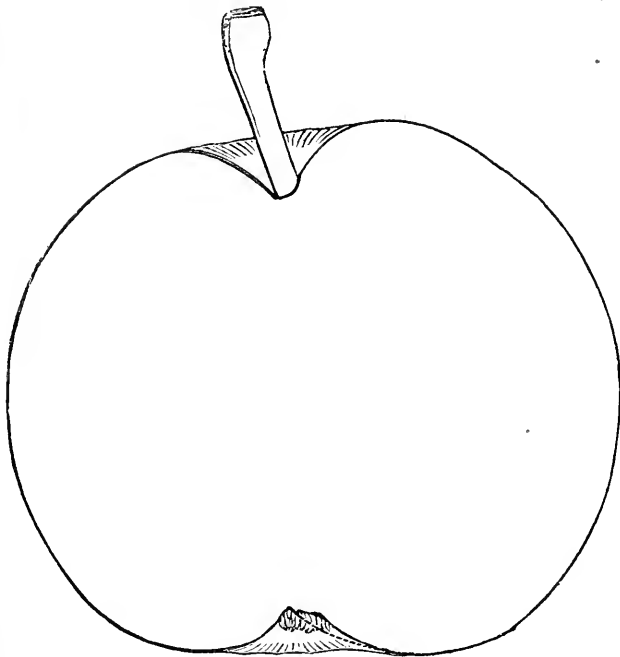

EASTER BEURRE.

17th April, in fine eating order—kept all winter in a cellar, on shelves, bringing them into a warm living-room ten days or so before wanted for use. Like the *Duchesse d'Angouleme*, it has been almost worthless with us on pear stock. We believe it is so in Europe, too;—at least, we have been told so, both in France and England, by experienced men. This accounts for its limited culture in this country; for, until seven or eight years ago, quince stocks were very little used for the pear. Good table winter pears are now attracting attention, and we believe that this variety will soon take its rank.

We think that for the south and west it will

still be better than for the north, as it seems to require long, clear, warm autumns, to bring out its excellence.

Large, roundish obovate, inclining to oval—large specimens rounder, and smaller ones more oval. *Skin*—rather rough, greenish yellow, with a dull red check on well matured specimens. *Stalk*—stout, about three-fourths of an inch long, set in a deep cavity. *Calyx*—closed, in a shallow, plaited basin. *Flesh*—buttery, melting, and high flavored. *Tree*—a fair grower. *Shoots*—reddish spotted. *Leaves*—folded, like those of the *Bartlett*. Exceedingly productive. Keeps till May.

MACHINE FOR CUTTING GRASS PLOTS.—It is not a little difficult to have a lawn well cut with a common scythe; few people know how to do it; and to those who do it, it is a laborious and tedious operation. A machine that would do it so easily and so well as that described below is said to do, would be of great value. The manufacturers say: "This unique and valuable adjunct to the pleasure ground and garden of the nobleman or gentleman, has now stood the test of twenty years' experience, and continues in as high repute as ever. One house alone have sold over fourteen hundred, which have given universal satisfaction; and is still in good demand. This machine is so easy to manage, that persons unpracticed in the art of mowing may cut the grass on lawns, pleasure grounds, and bowling greens, with ease. It is easily adjusted to cut to any length; and the beauty of its operation is, that it leaves no seam, nor any of the cut grass upon the lawn. Other advantages of this machine are, that the grass may be cut when dry, and consequently it may be used at such hours as are most convenient to the gardener or workman—while the expense of mowing is considerably lessened, as more than double the work may be done with the same manual labor that is requisite with the scythe."

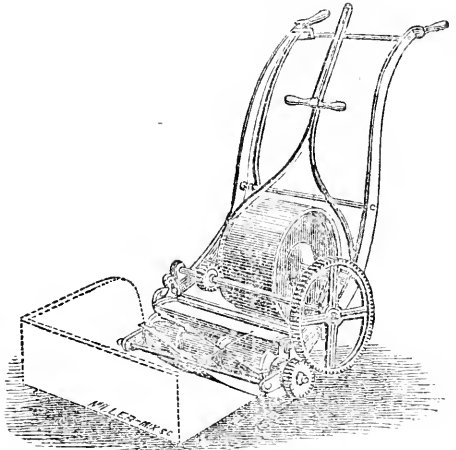

PATENT GRASS-CUTTER.

We saw this article for sale in most of the English Implement Warehouses, and all recommended it highly. We believe this or some similar ones have been introduced here, but we are not aware with what results.

HORTICULTURAL SOCIETY OF THE GENESEE VALLEY.—This Society held its first exhibition of the season on the 11th of May. The contributions were not numerous, but several articles were exhibited in greater perfection than they have before been seen here. The Society has not before ventured a show so early, and hence spring flowers and vegetables have not been brought out. There were—

From Mr. C. J. RYAN—a couple of fine plants, in pots, of the *Spiraea prunifolia*, loaded with its pretty, daisy-like, double flowers; (this plant forces well, and is one of the prettiest garden shrubs that bloom in May; it ought to be in every garden;) a couple of tubs of verbenas; a collection of hyacinths; &c.

From Mr. JNO. DONNELLAN—a nice collection of pot-plants, including a fine *La Reine* rose; several of the newest and best petunias; two pretty hand bouquets; &c.

From Messrs. A. FROST & Co.—fine specimens of *Cryptomeria*, and two large and handsome tree roses in pots.

From Messrs. ELLWANGER & BARRY—a superb show of thirty named varieties of hyacinths—the most attractive feature of the show; six varieties of crown imperials; a small collection of greenhouse plants, embracing azaleas, cinerarias, rhododendrons, and the beautiful *Tropaeolum tricolorum*.

Mr. DONNELLAN exhibited fine samples of the *Early Oval Rose* radish, of which we brought the seeds from France; also, of the *Early Frame*; very large *Palestine* lettuce; and a bunch of *Giant* asparagus, surpassing any we have seen in Rochester.

Mr. C. F. CROSMAN exhibited fine cucumbers, (the only ones shown;) also, fine lettuce, rhubarb, and asparagus; also, a dwarf orange, loaded with fruit.

Beautiful *Northern Spy* apples were shown by JAS. H. WATTS, in very tasteful glass jars.

Mr. VAN DOORN exhibited some well executed oil paintings of fruits, that were much admired.

The exhibition was well attended, and seemed to give general satisfaction to the visitors.

Ladies' Department.

GOLDEN BARTONIA.

THE *Golden Bartonia*, or *Bartonia Aurea*, was introduced into England, from California, in the year 1835, by the botanist DOUGLAS. Mr. D. introduced many beautiful flowers as the result of his botanical tour in California, and this is one of the most beautiful of them all. This excellent botanist was killed a few years after, by falling into a pit made to entrap wild cattle, in the Sandwich Islands. He introduced into England more ornamental annuals than any other collector.

"It is only beneath the bright sunshine," Dr. LINDLEY observes, "that its splendid flowers unfold. In the early morning, the plant is a shabby bush, with pale, greenish-grey branches, and weedy leaves; but as the sun exercises his influence, the petals gradually unroll, as if in acknowledgment of his power, till every branch is radiant with gold: and so metallic is the lustre of the inside of its petals, that one would really think they must be composed of something more solid and enduring than the delicate and perishable tissue of a flower."

The seed should be sown in a sheltered situation, (as the branches are very brittle, and easily broken by the wind,) in a rich, moist soil.



BARTONIA AUREA.

WE give the following valuable article on the *Treatment of Annuals*, from the *London Gardeners' Journal*. It is so good, and so appropriate at this time, that we could not forbear giving the whole article, thus occupying another page with our *Ladies' Department*.

"My flower-garden is small, but I like to see it gay. I endeavor to make it so, but I never succeed so well as I could wish. I have no convenience for wintering what are called bedding-plants, and my means will not allow me to spend much money in their purchase; but my friends, who know my love for flowers, and are acquainted with my circumstances, tell me I might accomplish a great deal by employing annuals. I have tried them for several seasons, and am not satisfied with the effect they produce. The greater part are so chary of their beauty, that they scarcely retain their charms for a week. Every shower, too, and every breeze, seems to destroy their attractions, and altogether I despair of attaining my object; yet certain it is, that from annuals I must principally expect my summer display of floral beauty. If you can furnish me with a few hints, and enable me at least to approximate my wishes, I shall be gratified."

"This note, which we give at length, contains the substance of one or two others which have come to hand on a like subject. At a corresponding season we yearly receive similar communications, and as the information required is of general application, we give our reply in such a manner as will, we trust, benefit not only those directly interested, but many of our readers besides.

"Annuals are calculated to effect much in the summer decoration of a flower-garden: their variety is great. In habit, in foliage, in the color of their flowers, they exhibit a great diversity, and from among them may be selected such as are suitable for all situations, and to please all tastes. But no plants are, as a general rule, worse treated than annuals. Because they are for the most part easily obtained, and as easily raised, they receive but a scanty amount of attention—certainly not of a nature to develop their proper character and value. As generally met with, they are weak, straggling, and weedy, easily damaged by rain and wind, and generally of but brief duration; yet if proper attention is afforded them in the several stages of their progress, they become highly effective and useful, both for cultivation in the open borders as well as for pots. Many of the kinds are admirably adapted for 'massing.'

"We shall now only speak of hardy kinds, such as may be sown in the borders where they are to flower, or in a reserve garden, and be afterwards removed to their permanent situations. When sown where they are to flower, the prevailing practice is to allow them to remain too thickly, smothering each other in their struggles for light and air, inducing a premature maturity, which of course is followed by their speedy dissolution. As soon as they are fairly above the ground thinning should commence, and be progressively followed up till in the place of fifty or more plants perhaps only five remain. Of course the distance at which it will be necessary to leave them will depend on the kinds, and on the richness of the soil. But the best system with the hardy kinds is to sow them in a spare piece of ground, and prick them out as soon as they are large enough, and only removing them to the flower-borders as vacancies may occur, or as they approach their flowering state; and by thus treating them, a good succession is always obtainable—a point of no mean import where they have to be depended on for a principal item in the summer display.

"In sowing them, a somewhat poor soil should be chosen; and when of a sufficient size to handle, choose a level spot, which can be shaded during the hottest part of the day, and after thoroughly beating or rolling it, to produce a hard surface, place upon it a layer of compost, chiefly composed of leaf-mold, in which plant the young annuals a few inches apart. With proper attention to watering and protection from insects, their progress will be rapid; abundance of roots will be produced, and the hardened surface beneath will preserve their roots from penetrating too far, to render their being transplanted safely. Here they will always be ready for removal to their blooming places. No check will result from their removal if the most ordinary care is observed. Scarcely a root will be lost in the process, and they become effective at once. Should they not be required till fairly in bloom, they may be as safely removed then as at any other time.

"It will be obvious that by a little attention to successional sowing, a supply of good plants may be obtained from the beginning to the end of the season."

FLOWER SEEDS.—We are still (20th May,) receiving applications for flower seeds. Some of our varieties were exhausted some time ago, and as we obtain our seeds from Paris, we have no opportunity to replenish. We, however, do the best we can with all applicants. At a great outlay of labor and money, we have now sent out seven thousand packages of seeds, averaging about thirteen varieties to each package, of the best annuals grown; and if these are well cared for, and the seed distributed judiciously, our labor will not be in vain.

Editor's Table.

NEW YORK STATE AGRICULTURAL SOCIETY.—We have received many communications complaining of certain acts of the State Agricultural Society, which we have not published, but we now give one below from one of the oldest and best farmers in Western New York. Among the things complained of is that those who have premiums awarded them must send to Albany for them, instead of receiving payment where the Fair is held. We think this is good ground for complaint. For a month or two after the last Fair not a day passed but from one to half a dozen persons called at our office to know where they could obtain their premiums. These claims were small, ranging from one to five dollars, others were entitled to a copy of Transactions. When informed that they must apply at Albany for their awards, and that the Transactions must be sent to the care of some one on the Express route, and the Express charges paid, a general dissatisfaction was expressed—some declaring they would take no further trouble, but abandon their premiums. We are sorry it is so; yet we believe that until the present feeling is entirely changed, the State Fair will receive very little countenance or support from this section of the State.

PERMIT me, through the pages of your useful journal, to express my views relative to the management of the New York State Agricultural Society. It appears to me that it does not give the encouragement and patronage to the producers, that was intended that it should do, and which it is capable of doing, provided that it is properly conducted.

An agricultural society is an association of the producing community, embracing all the productions that are useful, ornamental, or ingenious; and the primary object of the society is to elicit facts tested by experience, and circulate practical and useful information, to encourage and stimulate the practical operators to improvement, so as to enable them to produce more and a better quality of the earth's productions and all the various articles and commodities produced, so as to lessen their cost and increase their usefulness to the consumer; and the premiums are for the express purpose of encouraging and stimulating the operators to perfect these great objects.

The Fair is for the purpose of exhibiting all the multifarious productions of industry, art, and skill, in their greatest perfection; so that all who examine them may judge of their value, and learn by the united experience of the past how to improve and increase their productions. And it was expected that the statesman, the scientific, the professional, and the wealthy members of community, who wished to promote useful improvement and advance the interests of society, would attend the Fair and unite with the producers on true principles of quality, so as to exhibit by their actions that the cultivator of the soil, the mechanic, and the artisan, are the bone and sinew, and the supporters of society,—the most useful, and ought to be the most honored portion of community;—and also to exhibit to the

active and enterprising youth, that to be a practical operator in any of the useful vocations of life is as honorable as any of the heretofore dignified callings. But it was not so at the State Fair of 1851. The most of those dignitaries who attended were a privileged order—invited guests and honorary officers of the society. They were provided for and accommodated in extravagant style, at the expense of the Society and the citizens of Rochester; and were decorated with badges of estimation, as though they were of aristocratic blood, which spoke in language plainer than tongue could express, that they, the honored few, were the dignitaries of the realm, and that the producers were inferior beings; and the young men were compelled to see, that to be a practical operator is not the road to honor and distinction.

It never was intended that the State Fair should be a profitable festival to a few, at the expense of the producers; and it is a new principle in the management of agricultural societies, that the officers and wealthy citizens must be hired to attend the exhibition; and if such must be the case, in future we had better do without them, and appropriate the money that they cost to the encouragement of useful improvement.

It was not much of an encomium on the intelligence of our cultivators, that the Society had to send to Illinois and get a politician to preach politics for the improvement of agriculture in the Empire State. And how much it cost the Society, is best known to those who handle the money. There were a hundred men on the ground, that could have given a better and more practical agricultural address. A PLOW-HOLDER.

TRIAL OF IMPLEMENTS.—We call particular attention to the Trial of Implements by the N. Y. State Ag. Society, at Geneva, in July, the particulars of which will be found in advertisement.

TOBACCO.—In the March and April numbers of your paper you gave directions for the cultivation of tobacco. As I have always considered the *Farmer* devoted to the improvement of the soil and the mind, I am at a loss to know how the cultivation of tobacco is to improve (either, when we see that those who do not use the weed have the best health, to say nothing about the filth connected with its use, and the number of tobacco users that lament the day they ever learned to use it. All this is an unanswerable argument against the use of tobacco as a luxury for man. Then why cultivate it? Why impoverish the soil to reproduce that which makes man filthy and diseased? I am surprised that the *Farmer*, which for years has been laboring to improve the taste, and induce its readers to engage in the culture of wholesome and refreshing fruits, beautiful and sweet smelling flowers, should ever have polluted its pages with a description of the culture of tobacco. Had you recommended the culture of Canada thistles or pigeon weed, I could have pardoned you; for, great as the injury of these weeds is to the farmer, they can be turned to some use in the end. Sheep will eat the young thistle when cut and dried as hay, and oil is extracted from the seed of the pigeon weed. I know that a great number of *asses* use tobacco, but I never knew one that grew fat on it.

But if you or your correspondent recommends its culture, then give us some directions for its use. Let us know how large a chew of tobacco a boy may take without killing him; or how long he may suck a cigar before it will puke him. Let us have the picture of a pipe and the outline of a tobacco box, to place by the side of an outline of fruit in the *Farmer*.

What an association there would be between a pear and a plug of tobacco! If ever this world is to return to its Eden-like purity, and ignorance and crime be known no more, then first must tobacco, as well as intoxicating drinks, be banished from the daily use of our young men. And when this is done, then will universally commence the culture of those fruits and flowers that you have so long and earnestly recommended to the readers of the *Farmer*. RICHARD JOHNSON.—*Elst Groveland, N. Y.*

We give the above a place in our columns, not because we think the strictures called for by anything we have said, or that we have "*polluted our pages*" by giving the best method of raising tobacco. Had we recommended the use of tobacco, or even its general growth, then the ease would have been far different, and there would have been some propriety in the censure so liberally bestowed; but, so far from this, although it is not our business as editors of an agricultural journal, to tell men what they shall eat or what they shall drink, yet we have dropped a word or so against the use of tobacco, and even in the article complained of stated "we did not wish to see tobacco raised here as a common crop." We have often wished that, if men would smoke and chew a noxious weed, one could be discovered nasty enough to suit, and less exhausting to the soil than tobacco. But when our readers solicit information on the growth of any crop, we do not feel at liberty to withhold it because we may think the use of the article deleterious. We have now several letters asking the best method of growing hops; and as we feel under obligation to answer these inquiries, we hope our correspondent will not accuse us of encouraging the use of beer. We suppose tobacco will be grown as long as there is a good market for it; and if we tell how it can be grown with the least possible injury to the soil, we shall accomplish some good: but if the world would follow our example as well as our advice, there would be little need for the information.

Inquiries and Answers.

SUPERPHOSPHATE OF LIME.—In your May number, SILAS H. MEACHAM inquires where the superphosphate of lime of good quality may be obtained, and what is the price. You say, in answer, "It is being manufactured by the New Jersey Zinc Co., and is for sale in New York city at 2½ cents per pound," (price of guano.) This manure may be manufactured by Mr. MEACHAM, or any other expert farmer, for less than one cent per pound, and the certainty of having a pure article and saving his 1½ cents to expend in agricultural works.

The plan I adopt to dissolve bones, is to have them ground as fine as I can, put them into a wooden vessel, pour on as much water as will wet them, generally till it rises to the upper surface;

then pour in sulphuric acid, 40 lbs. to 100 of bones; stir them frequently, until dissolved. After the bones are dissolved, I mix them with as much earth as will enable me to spread it over the field. The cost will be—

For Bones,	100 lbs., at 1 cent per lb.,	\$1 00
Sulphuric acid,	40 lbs., at 2½ cts. per lb.,	1 00
Water,	80 lbs.,

And we have 220 lbs. of the manure for. \$2 00

and I have not much doubt a better article than the one made by the Zinc Company.

Last year I raised some mangel wurzels, and manured some of them with this manure put in the bottom of the drills, and they were better than where I put barn-yard manure. The above amount of this manure is sufficient for an acre of wheat, which it will improve to the satisfaction of the farmer. The timothy after my wheat thus dressed was the best I ever cut; I think it paid four or five times the cost of the manure. There is no manure made that is so cheap as this superphosphate of lime. S. G.—*London Britain, Pa.*

We have often recommended our readers to preserve bones, and convert them into superphosphate of lime; but, as many farmers have no bone mill in their neighborhood, and getting sulphuric acid is somewhat troublesome, it would be a great advantage to have a good article that could be purchased ready for use at a reasonable price—two and a half cents per pound we think an exorbitant one; and, as it is manufactured from a mineral phosphate of lime, and contains no organic matter, the bone-made superphosphate would be a superior article for wheat and other grain crops. It is said, however, that the mineral contains 90 per cent. of bone-earth phosphate, and as bones contain but 45 per cent., the mineral-made superphosphate of lime will be the best article for mangel wurzel, beets, ruta bagas, turnips, and all crops which are particularly benefitted by phosphate of lime.

The method of dissolving bones as recommended by our correspondent, is a good one. It is preferable to mix the water with the bones previous to adding the acid, than to mix it with the acid before applying it to the bones.

The term "dissolving bones with acid," is apt to convey a wrong impression of the process. The acid does not dissolve them, but simply converts the phosphate of lime into a bi-phosphate, or super-phosphate, of lime. This it accomplishes by abstracting a portion of the lime, setting free its phosphoric acid, which unites with the undecomposed phosphate, converting it into the bi-phosphate of lime.

The value of the change is this: *Phosphate* of lime is insoluble in water; *bi-phosphate* or *super-phosphate* of lime is exceedingly soluble: so that,

as plants only take up their constituents in solution, it will be perceived why the superphosphate of lime is so much more efficacious the first year than bones, five bushels of superphosphate of lime producing a larger crop of turnips than fifty bushels of roughly ground bones. Bones undergo a gradual decomposition of themselves, when mixed with the soil, yielding their constituents to the water and plants, the organic matter being soonest in an assimilable condition. Hence, bones applied to wheat are attended with good results in many instances; while superphosphate of lime made from minerals does no good.

It is very questionable whether it will pay to decompose bones with sulphuric acid, to be applied to wheat. Our own opinion is, that it will not,—that the bones would do about as much good without the acid as with it; but for root crops, the superphosphate of lime is the best manure we have ever used. The present month is the proper time for sowing mangel wurzel, beets, and ruta bagas. For these crops the superphosphate, whether from bones or minerals, will be greatly beneficial, and will pay well. (See March number, page 82.)

DAIRY, OR MILK-HOUSE.—I send you a design and specifications for a dairy, or milk-house, which you may give to your readers, if you think it worth a place in your journal, and do not find one answering E. H.'s wants more fully

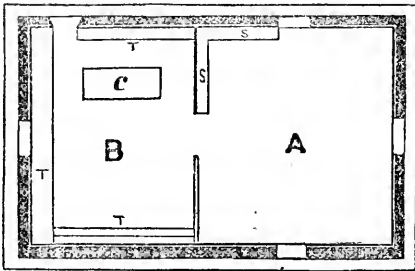

PLAN OF DAIRY, OR MILK-HOUSE.

The building is 10 by 18, which I think large enough for a private family; but should any one wish to enlarge it, it might be made 10 by 20, or 15 by 25, without altering the plan.

The foundation is laid with stone, and raised 2½ feet above the surface. Upon this is set the frame, and enclosed by vertical weather boarding. The distance from the stone to the eaves is 8 feet, and to the comb 12 or 14 feet; because a steep roof will turn rain better, last longer, and keep the interior cooler, than a flat one.

A is the front room, used for various purposes—to keep empty vessels in, and such other things as are used about a dairy, and is also a pleasant place in summer to churn in. The floor of this

room is laid with plank, level with the top of the stone.

Steps lead from this room down to the milk-room, B, the floor of which is laid with brick or stone. Stone I consider preferable, for reasons given hereafter. The dairy table, c, occupies the centre of the room, and is used to place pans upon when the milk is to be skimmed, and also while straining the milk. T, T, T, are troughs, made of stone or cement, in which to place the pans when filled. The water is conveyed to and from these troughs by means of lead pipes.

The cost will vary from \$50 to \$70; \$70 being in my opinion, more than enough to finish in plain style a house of the above mentioned dimensions. The bill of costs might thus be summed up, at the highest prices:

Mason's bill, including stone,.....	\$12 00
600 feet of plank for weather boarding,.....	6 00
2000 shingles, at \$5,.....	10 00
Carpenter's bill, including nails and glass,.....	20 00
Sundries, including hire of extra help,.....	12 00

Amount,.....\$70 00

I would say to E. H., that he need not be afraid of having too much ventilation. Don't put tan bark about your milk-house, and never allow any decaying matter to come near it. Never put lime into it to absorb any such matter, but apply plenty of cold water, and admit the sun and air plentifully. Lay the floor of the milk-room with stone, as they will not absorb "spilt milk" like brick or wood, and cause an unpleasant odor to pervade the rooms. Make the roof steep, as this tends to keep off the rays of the sun, and leaves the interior cool, and you will have no use for tan bark. Above all things, though, keep your milk-room clean, and then you will not be troubled with the unpleasant thought of having to eat an old dish rag, or other decayed matter, that has been absorbed by your cream. AN OREGON FARMER.—*Hillsboro, Ohio.*

TO PRESERVE GIRDLED TREES.—In the April number of the Farmer, page 129, J. H. L., of East Charlemont, Mass., inquires if any of your correspondents know how to preserve trees that have been girdled. Tell him to take out a block of wood extending into the bark above and below the girdle, and take from the body or limb of another tree a block corresponding in size and shape, with the bark on, and adjust it in the place, and bind it there, on the principle of engrafting. I have recommended this plan before, and it has proved completely successful. C. MOORE.—*Port Clinton, Mich.*

Northern N. Y. Live Stock Insurance Company, Plattsburgh, N. Y. For terms, please apply to agents of the Company.

Superphosphate of Lime

FOR SALE in lots to suit purchasers, warranted pure, at 2½ cts. per pound. LONGETT & GRIFPING, State Ag. Warehouse, 25 Cliff st., New York. June, 1852.—6-2t.

Peruvian Guano.

AND other Fertilizers. Several hundred tons of first quality of Peruvian Guano, constantly on hand for sale. Also, Bone Dust, Plaster of Paris, and Poudrette. A. B. ALLEN & CO., April, 1852.—1t. 159 and 191 Water-st., New York.

NEW AND FINE SHRUBS AND PLANTS.

ELLWANGER & BARRY, Proprietors of the Mount Hope Nurseries, Rochester, N. Y., solicit the attention of those interested in Ornamental Plants to their large stock of rare and beautiful shrubs and Plants, among which are the following:

HARDY SHRUBS.

Deutzia Scabra, or Garland Deutzia, a fine white flowering shrub.
Koehysthia Viridissima.
Ribes Gordonii—Gordon's Currant—yellow and crimson, very fine.
Spiraea Prunifolia flore pleno—small, double, white flowers in great profusion; fine dense habit.
Spiraea Lanccolata, or Keevesi, one of the finest of the genus.
Spiraea Chamædrifolia, *Nicoerdertii*, *Lindleyana*, *Japonica*, and twenty others.
Syringa (Philadelphus) *Pubesces*, *Zepherii*, *Cordata*, *Double*, *Columbiana*, and others, all fine.
Lonicera Ledbourii—a fine Californian shrub.
Tamarix, *Africana*, *Germanica*, *Gullica*, and *Lebanotica*.
Fiburnum Lantanooides, a beautiful shrub.
Wiegela Rosa—the finest hardy shrub, lately introduced from China.
 The above excellent things can be furnished in quantities, at low prices.

SELECT GREEN-HOUSE AND BEDDING PLANTS.

FUCSIAS.—Our collection is one of the best in America. The most distinct and best varieties yet introduced and quite rare, such as *Pearl of England*, *Fair Rosanona*, *Serratifolia*, *Serratifolia multiflora*, *Fulgens Corymbiflora*, *Corymbiflora alba*, *Magnificent*, *President*, *President Porcher*, *Spectabilis*, &c., are propagated largely.

VERBENAS.—A collection of fifty varieties, comprising everything fine introduced to this time.

HELIOTROPES.—*Souvenir de Liege*, *Corymbosum*, and some new varieties just received and to be announced hereafter.

PLUMBAGO LARVENTE.
CYPRIAS.—*Platycentra*, *Stringulosa*, and others. The first is one of the finest bedding plants.

LANTANAS.—*Eringii*, the fine new Cincinnati variety, rose and straw color; *Antabilla Major*, and several others.

BOUVARDIAS.—*Triphylla*, and others.

ABUTILONS.
SALVIAS.—*Splendens Major*, *Oppositifolia*, *Azurea*, and others—superb plants for masses.

FABIANA IMBICATA.
HYDRANGEAS.—*Hortensis*, *Japonica*, *Cordata*, &c.
Buddlea Lindleyana—a fine shrubby plant with large clusters of purple lilac flowers; blooms in the autumn.

HABROTHAMUS ELEGANS—a superb plant, half shrubby, with large clusters of showy crimson flowers; blooms equally well in the open ground in autumn, and in the house in winter.

PETUNIAS.—A large collection, embracing all distinct and good sorts.

LOBELIA FULGENS INSIGNIS, **LOBELIA FULGENS ALBA**—flowers of dazzling beauty—both new.

VERONICA LINDLEYANA—a charming autumn flowering plant; long elegant spikes of pale (nearly white) blossoms. *Veronica Andersoni*—finest of all—new.

TREE VIOLETS—white and purple.
CHRYSANTHEMUMS.—A fine collection of the novel and beautiful pomponé or dwarf varieties.

DAHLIAS.—A superb collection, including the English and French prize sorts of 1851—all at very low rates.

CINERARIAS.—A fine collection of new and beautiful sorts, including *Magnificent*, *Atilla*, *David Copperfield*, *Wellington*, *Beauty of Newington*, &c. &c.

All the above articles furnished in large or small quantities, at low rates, and packed so as to go any distance with safety.

Priced Catalogues of Dahlias, &c. &c., ready 1st of March. March 1, 1852.

Albany Tile Works,

No. 60 Lancaster St., West of Medical College.
 THE subscriber has now on hand, and is prepared to furnish to Agriculturists, Horse-Shoe and Sole Tile, for land drainage, of the most approved patterns. They are over 1 foot in length, 2½ to 4½ inches calibre, from \$12 to \$18 per 1000 pieces—being the cheapest and most durable article used. Orders from a distance will receive prompt attention.
 [4-6] JOHN GOTT, Jr.

MOORE'S RURAL NEW-YORKER:

A WEEKLY HOME NEWSPAPER;

Designed for both Country and Town Residents.

THIS Journal, now in the third year of its existence, has attained an extensive circulation and acquired a high reputation. It embraces more Agricultural, Horticultural, Mechanical, Scientific, Educational, Literary and News matter, interspersed with numerous Engravings, than any other paper in the Union—and has no superior as an AGRICULTURAL AND FAMILY NEWSPAPER. Its various departments are under the supervision of an efficient corps of Editors, who are determined to render the contents of the whole paper USEFUL, PURE, AND ENTERTAINING. They are assisted by a large corps of Contributors and Correspondents,—including several popular Authors and Editors,—capable of adding interest and value to the pages of any publication.

The NEW-YORKER is published in the BEST STYLE. Each number contains EIGHT DOUBLE QUARTO PAGES, (forty columns,) illustrated with from two to six Engravings. It is pronounced by its Patrons and the Press the MODEL PAPER of its class, in both Contents and Appearance—and we invite all who desire a FIRST CLASS JOURNAL, for the Home Circle, to give it an examination, and, if approved, support.

TERMS—IN ADVANCE:—Two Dollars a year—\$1 for six months. Three copies one year for \$5; Six copies, and one to agent, for \$10; Ten copies, and one to agent, for \$15; Twenty copies for \$25. Specimen numbers sent free.

Subscriptions respectfully solicited,—to commence with any number. Back numbers to 1st May or April, furnished if desired. A new half volume commences 1st July, and hence now is a good time to subscribe. Money, properly enclosed, may be mailed at the risk of the Publisher. Address D. D. T. MOORE, June 1, 1852. Rochester, N. Y.

THE NEW YORK REAPER.

MR. McCORMICK, in an advertisement recently published, says, "that while Seymour & Morgan are going on to manufacture more reapers, they have made no provision to pay the judgment against them for \$17,306; and another suit for infringement in the manufacture of five hundred reapers since the commencement of the first is about to be brought against them—and that, if they fail to pay the damages, the purchasers are not only liable, but may at any time and will be sued for the same."

In answer to this, we say, that Mr. McCormick has no judgment against us for \$17,306, or for any other sum. He obtained a verdict against us for upwards of \$17,000, on account of the machines which we manufactured and sold in 1850; but proceedings were immediately taken on our part to present the case to the U. S. Supreme Court, before which tribunal we hope to obtain a new trial, and in that case feel very confident that we can now make a successful defence. If we should be disappointed in this, we expect to pay the verdict, unjust as we know it to be.

With regard to the machines we are now building, Mr. McCormick very well knows that they contain not a single feature which is embraced in any unexpired patent of his, and that we have as much right to build and sell them without reference to him, as farmers have to plow their lands without asking his permission. It will be observed that he does not pretend, in his advertisement, that THE MACHINES WE ARE NOW CONSTRUCTING are any infringement of his patents.

The 500 machines which we sold last year were no infringement of his rights, and if he should see fit to carry his threat of prosecuting us into execution, it will be for the purpose of frightening, and deterring farmers from purchasing machines of us this year, and not with the expectation of obtaining a verdict against us. His object is to drive us out of the business of making Reapers, that he may have the entire field to himself. This, if truth and justice are allowed to prevail, he can not do.

Those wishing the New York Reaper for the ensuing harvest, will do well to give us their orders early, as we have heretofore been unable to supply the demand.

SEYMOUR & MORGAN.

Brookport, May 18, 1852.

THE subscriber deals in, and sells on commission, all kinds of good patents. Worthless ones need not be offered.

A good Grass Mower wanted.

The best of reference given.

ALLEN VANE,

No. 157 South Water Street, Chicago, Ill. April 10, 1852.—5-3L

New York Agricultural Warehouse,

189 & 191 Water Street, New York.

A. B. ALLEN & CO.

HORSE POWERS, Threshers, and Separators. The Endless Chain or Railway Powers of our own manufacture, both single and double geared, for one and two horses, which has never been equalled for lightness in running, strength, durability, and economy. They are universally approved wherever they have been tried.

2d. The Bogardus Power, for one to four horses. These are compact and wholly of iron, and adapted to all kinds of work.

3d. Eddy's Circular Wrought-Iron large Cog Wheels, for one to six horses. A new and favorite power.

4th. Trimble's Iron-sweep Power, for one to four horses. **THRUSHERS**—Improved Threshers made upon the best principles, threshing clean with great rapidity.

FAN MILLS for Wheat, Rye, Oats, &c., of the best construction.

RICE FAN MILLS made expressly for the South.

MILK PANS—Glass and Enamelled Iron Milk Pans, very desirable articles.

CHURNS—Thermometer, Atmospheric, Kendall's, and other kinds.

HAND CULTIVATORS and Hand Plows—are very useful implements in garden culture.

SCYTHES—Grass, Grain, Bush, and Lawn Scythes of the best kinds.

RAKES—A large assortment Steel, Iron, and Wooden-headed Garden Rakes, and Lawn and Hay Rakes.

HORSE HAY RAKES of new and highly improved patterns. **RAPING AND MOWING MACHINES**—These have been fully tested, and embrace many late improvements, and we can highly recommend them.

GARDEN AND FIRE ENGINES, very useful machines, arranged on wheels, for watering gardens or walks, and affording protection from fire. They will throw a strong stream forty feet high, are easily worked, and not liable to get out of order. Also, small Garden Pumps and Syringes of various styles.

HAY AND COTTON PRESSES—Bullock's Progressive Power Presses, combining improvements which make them by far the best in use.

WATER RAMS, Suction, Force, and Endless-Chain Pumps; Leather, Gutta-Serena, India-Rubber Hose, Lead Pipe, &c.

CABBAGE PLOW—Very light and convenient for working among cabbages.

POTATO PLOW, with double mould and other forms for hilling and weeding.

Our implements occupy three large stores, and we believe they make up the largest and most complete assortment in America. In addition, we have a machine shop, employing upwards of one hundred men, where any articles in our line can be made to order.

A. B. ALLEN & CO.,

June, 1851.—6-1f. 189 and 191 Water St., New York.

Fruit Farm in Ohio for Sale.

"**POMONA FARM**"—120 acres of excellent land; 50 acres young orchard, containing 3000 peach and 2000 apple trees of the choicest market varieties, commencing to bear, and partly enclosed with Osage Orange hedge. About 40 acres is woods pasture with living water. The soil is strong loam, well adapted for grain and grass, as well as fruit—was especially designed for fruit, stock, and poultry—about 100 improved fowls are on the premises. The buildings are of little value. The situation is very healthy and pleasant; good water; schools and other social advantages convenient.

The farm is situated at the thriving village of West Jefferson, 14 miles west of Columbus, at the intersection of the "National Road," the "Xenia Turnpike," and the "Cleveland, Columbus, & Cincinnati Railroad"—only 100 rods from the village and depot—thus affording excellent facilities for travel and transportation, with certain markets for products. It will be sold at a bargain.

Address M. B. BATEHAM,

Editor Ohio Cultivator, Columbus, O.

June 1, 1852.—6-2f*

GERVASE WHEELER, Architect,

NORWICH TOWN, CONNECTICUT,

RESPECTFULLY solicits professional engagements from those desirous of building. Designs for residences, churches, school-houses, arrangement of grounds and out-buildings, and for internal decoration, prepared and forwarded by express. Terms moderate—two dollars charged for such information as can be given in a letter.

GREAT SALE OF BLOOD CATTLE.

ON Wednesday, the 15th of August next, I will sell the chief part of my large herd of Blood Cattle—chiefly cows, heifers, and heifer and bull calves—comprising upwards of fifty full-bred Short-Horns.

Also, eight thorough-bred Herefords—a two years old bull, a yearling bull, three cows, and three calves. One of the Hereford cows ("Rarity") was imported from England by Messrs. Corning & Southam, in 1841. The others, excepting the two years old bull, are her descendants, by bulls of the same stock.

Also, two or three Devon bull calves, got by Mr. Ambrose Stevens' imported bull "Candy," bred by the distinguished Mr. Quarly, of Devonshire, England, and out of cows descended from the herd of the late Earl of Leicester.

The remainder of the cows and calves, forty to fifty in number, are high-bred Short-Horn grades, with a dash of Devon blood in some of them.

The calves of the thorough-bred Short-Horns and grade cows, are mostly got by the imported Short-Horn bull "Duke of Exeter," (10,152.) of the celebrated "Princess tribe," bred by Mr. John Stephenson, of Durham, England, whose herd is excelled by none, if equalled, by any now in England.

All the Short-Horn and grade cows and heifers which come in season, will be bulled, previous to the sale, by "Duke of Exeter."

Many of the cows, both thorough-bred and grade, are descended from the Bates bulls "Duke of Wellington," imported by George Vail, Esq., of Troy, N. Y.; and by "Symmetry," son of "Wellington," out of Mr. Vail's imported Bates cow "Duchess."

This stock has been bred with a strict regard to their milking quality, in which they have been fully proved, and are not excelled by any herd of cows in the United States. They are all gentle, with fine silky udders, milk easy, and are animals that will be satisfactory to any one in want of the best breeding and milking stock.

The sale will take place at the residence of Peter Gurbra, two miles above Albany, on the Troy road, on the homestead farm of Gen. Van Rensselaer, where the cattle will be for a week before the sale.

Catalogues with pedigrees will be prepared by the 15th of June, and sent by mail to all post-paid applicants.

I will also sell at the same time, two pairs of six years old thorough-bred Short-Horn oxen, and two or three pairs of matched steers.

Also, ten or twelve South-Down buck lambs, got by an imported ram, from the unrivalled flock of Jonas Webb, of Babraham, England, and from Ewes descended from the flocks of Mr. Webb, and Mr. Ellman of Sussex.

LEWIS F. ALLEN.

Black Rock, N. Y., May, 1852.—6-2f*

The Celebrated Horse "Morgan Eagle."

THIS truly celebrated horse will stand for Mares this season, commencing April 19th, at the Franklin House in Genesee, on Monday, Tuesday, Wednesday, and Thursday, and at Scoville's Eagle Hotel in Mt. Morris, on Friday and Saturday of each week during the season.

"Morgan Eagle" was purchased in the fall of 1847, in Tunbridge, Vt., by J. Henderson, at a high price, for the express purpose of improving the stock of horses in this county. He is about 16 hands high, and well proportioned, is a bright bay, and for symmetry and action, cannot be surpassed. Morgan Eagle, and the celebrated trotting mare, Lady Sutton, of New York, were sired by Old Morgan Eagle, of Vermont.

Breeders of horses are particularly requested to call and examine him.

Pasture will be furnished for mares sent from a distance and good attention paid to them. Escapes at the risk of the owners. Those who part with mares before foaling, will be held responsible for the insurance. Mares must be returned every two weeks or they will be held for the insurance.

J. HENDERSON & Z. H. AUSTIN,
Genesee, April 16, 1852.**Improved Subsoil Plows.**

THE subscribers offer for sale an Improved Subsoil Plow, made under the advisement of Prof. J. J. Mages, and free from the objections urged against those formerly in use. The wearing parts are so arranged that they may be easily and cheaply renewed, while the amount of force requisite to move them is less than half that required by those previously made.

Price—One Horse Plow, \$5; with draft rod, \$6. No. 1, with draft rods, \$3.50. No. 2, do., \$11.

LONGFETT & GRIFFING,

June, 1852.—6-3f. No. 25 Cliff street, New York.

DURHAM CATTLE.

I HAVE imported several cows and heifers of the celebrated Princess Tribe of Short-Horn Durham Cattle, bred by and from the herd of John Stephenson, England. This tribe is unequalled in England or America, for style, quality, and milk.

In connection with Col. Sherwood, I imported the prize bull Third Duke of Cambridge, (2,941,) bred by the distinguished breeder, Thomas Bates, of England, and got by his famous prize bull, Duke of Northumberland (1,949). We also imported from Mr. Stephenson, the Princess prize bull, Earl of Seatham, (19,181). I have also imported Princess I, Princess II, Princess III, Princess IV, Princess V, and the bulls Wolviston and Earl Vane, all of the Princess Tribe, and bred by Mr. Stephenson. I also imported the cow Waterloo V, bred by Mr. Bates, got by his prize bull Duke of Northumberland, and of the same family as Third Duke of Cambridge. I also purchased of Mr. Ramsay, the cow Wildgeese V, bred by Mr. Bates, and bought by Mr. Ramsay at the sale of Mr. Bates' cattle, in England, in 1859.

I am now breeding these imported cows and heifers, to the imported prize bulls Third Duke of Cambridge, Earl of Seatham, and Vane Tempest; also, to Wolviston and Earl Vane. I can supply breeders with bull calves out of these cows and heifers, got by these imported bulls, of a red or roan color, as may be preferred.

The Third Duke of Cambridge won the first prize for Durham bulls at the Show of the New York State Agricultural Society, at Syracuse, in 1859, beating among others, three bulls of Mr. George Vail's (of Troy) breeding, including Buena Vista. He also won the first prize for Durham bulls at the show of the same Society at Albany, in 1859, beating among others, Mr. George Vail's bull Meteor.—(Meteor by Mr. Vail's imported Bates Lull Wellington—dam, Mr. Vail's imported cow Duchess.)

Earl of Seatham won the first prize for two-year-old Durham bulls at the Show of the same Society at Albany, in 1859, beating Mr. George Vail's bulls Fortune and Eclipse. Seatham won the first prize for Durham bulls of all ages two years and over, at the Show of the American Institute in New York, in 1859. Seatham also won the first prize for Durham bulls at the Show of the New York State Agricultural Society at Rochester, in 1851, beating Mr. Lewis G. Morris' prize bull Lamartine, and many others.

Princess I won the first prize for yearling Durham heifers at the Show of the New York State Agricultural Society at Syracuse, in 1859, beating Mr. Chapman's Bashi, a from Mr. Vail's herd. Princess II also won the first prize for two-year-olds at the Show of the same Society at Albany, in 1859, beating, among others, Mr. George Vail's two heifers, Hippa 2d (got by Mr. Vail's imported Lull Wellington, out of his imported cow Hipp 1st) and Eunice 4th.

Princess I is the dam of Col. Sherwood's prize bull Vane Tempest. At the Show of the New York State Agricultural Society at Albany, in 1859, as a bull calf, and at the Show of the same Society at Rochester in 1851, as a yearling bull, Vane Tempest won the first prizes, beating, in both instances, Mr. Vail's bull Kirklevington (got by Mr. Vail's imported Wellington, out of imported Lady Barrington.) Of these imported cows and heifers, Princess II has alone been shown. Wolviston and Earl Vane have not been exhibited.

Third Duke of Cambridge is the only bull now in America bred by the celebrated Thomas Bates of Kirklevington, England, and is the best bull ever brought to America from Mr. Bates' herd.

Wolviston is brother to Earl of Dublin, bred by Mr. Stephenson, that is now let at a high price, to that celebrated breeder, Sir Charles Knightley, Leicestershire, England. Earl Vane, now a yearling, is brother to Vane Tempest.

Breeders desiring the blood of Mr. Bates' herd, can nowhere else in America, than from Third Duke of Cambridge, procure it with such high characteristics of style, quality, symmetry, and substance.

Breeders buying bulls of the Princess Tribe, will get those which are superior to all other Short-Horn Durham Cattle. All Mr. Bates' great leading prize animals, winning at the great English Shows, viz: Duke of Northumberland, Duchess 34th, Duchess 42d, Duchess 43d, Cambridge Rose, &c., were got by Mr. Stephenson's Princess Tribe bull, Belvedere, (1,706,) and he never got beaten when he showed the get of Belvedere.

As feeding beasts, no Tribe ever surpassed the Princess. Earl of Seatham in six months, March to September 1851, made over 600 pounds growth.

The Princess Tribe of Short-Horns is concededly the best milking tribe of Durham cattle in England; all the cows of the tribe milk copiously. Of the four which have dropped calves for me, all are very fine milkers. Princess I, at four years old, has given twenty-six quarts a day, very rich milk.

And Princess IV, with her first calf, has given twenty-two quarts a day. Col. Sherwood's Red Rose of this tribe, four years old, getting grass only, made in thirty successive days of May and June 1851, sixty pounds and four ounces of butter; and forty-seven pounds and eleven ounces in thirty successive days in August 1851, which was a period of great drouth.

C-10-a AMBROSE STEVENS, New York city.

LEWIS G. MORRIS'

THIRD ANNUAL SALE, BY AUCTION,

OR

IMPROVED BREEDS OF DOMESTIC ANIMALS, Will take place at Mount Fordham, Westchester Co., (11 miles from City Hall, New York,) on WEDNESDAY, JUNE 9, 1852. JAMES M. MILLER, Auctioneer.

APPLICATION need not be made at private sale, as I decline in all cases, so as to make it an object for persons at a distance to attend. Sale positive to the highest bidder, without reserve.

Numbering about fifty head of Horned Stock, including a variety of ages and sex, consisting of Pure Bred Short Horns, Devons, and Ayrshires; Southdown Buck Lambs, and a very few Ewes; Suffolk and Essex Swine. Catalogues, with full pedigrees, &c., &c., will be ready for delivery on the first of May—to be obtained from the subscriber, or at the offices of any of the principal Agricultural Journals or Stores in the Union. This sale will offer the best opportunity to obtain very fine animals I ever have given, as I shall reduce my herd lower than ever before, contemplating a trip to Europe, to be absent a year, and shall not have another sale until 1854.

It will be seen by reference to the proceedings of our State Agricultural Society, that I was the most successful exhibitor of Domestic Animals, at the late State Fair.

I will also offer a new feature to American breeders—one which works well in Europe; that is, *letting the services of male animals*; and will solicit propositions from such as see fit to try it. Conditions—The animal hired, to be at the risk of the owner, unless by some positive neglect or carelessness of the hirer; the expense of transportation too and from, to be borne jointly; the term of letting, to be one year or less, as parties agree; price to be adjusted by parties—to be paid in advance when the bull is taken away; circumstances would vary the price; animal to be kept in accordance with instructions of owner before taking him away.

In offer on the foregoing conditions, three celebrated prize bulls, "Major," a Devon, nine years old; "Lamartine," a Short Horn, four years old; "Lord Eryholme," Short Horn, three years old. Pedigrees will be given in Catalogues.

At the time of my sale, (and I would not part with them before,) I shall have secured two or three yearly sets of their progeny; and as I shall send out in August next a new importation of male animals, I shall not want the services of either of these next year. I would not sell them, as I wish to keep control of their propagating qualities hereafter.

I also have one imported buck, the prize winner at Rochester last fall, imported direct from the celebrated Jonas Webb; and also five yearling bucks, winners also, bred by me, from bucks and ewes imported direct from the above celebrated breeder. They will be let on the same conditions as the bulls, excepting that I will keep them until the party hiring wishes them, and they must be returned to me on or about Christmas Day. By this plan, the party hiring gets rid of the risk and trouble of keeping a buck the year round. All communications by mail must be pre-paid, and I will prepay the answers. L. G. MORRIS.

Mount Fordham, April, 1852.—5-2t.

Field Seeds.

AUSTRALIAN WHEAT—very superior. The berry of this grain is extra large, and makes the best of flour. It produces a greater average crop than any other variety now grown in New York. Several years' experience in its cultivation, proves that it is less liable to rust or mildew than other kinds; and as the stalk is large and strong, it is also less liable to blow down or lodge. Price, \$4 per bushel. Other varieties of wheat, such as the White Flint, Mediterranean, Black Sea, &c.

BROXWATER, of the best kinds in market.

RITA BAGG, or Swedish Turnep Seed. The Purple Top and other superior varieties.

TURNIP SEED—Large White Flat, Long White, Red Top Flat, Yellow Aberdeen, Yellow Stone, and other improved kinds for the field or garden. A. B. ALLEN & CO., June, 1852.—6-1f. 189 & 191 Water st., New York.

Prices of Agricultural Products at the Principal Markets in the United States. — May 29, 1852.

	New York.		Boston.		Rochester.		Chicago.		Cincinnati.		Philadelphia.	
Beef, per 100 lbs.....	\$6.00	a 7.50	\$6.00	a 7.50	\$5.50	a 6.00	\$1.00	a 4.25			\$1.25	a 5.25
do mess, per bbl....	9.75	12.75	12.00	15.00	10.00	10.50					16.00	16.50
Pork, per 100 lbs....					7.00	7.50	4.00	4.12½				
do mess, per bbl....	9	18.50	19.00	20.00	16.00	16.50	17.00	9%	\$16.37	a 16.50	19.00	20.00
Lard, per lb.....	15	21	10	11½	9	10	9	9%	8	10½	10½	11½
Butter, do.....	6½	8	6	9	7	8	5	7	6½	7½	14	16
Cheese, do.....	4.00	5.75	4.75	5.75	4.62	4.75	4.00		3.22		4.25	5.25
Flour, per bbl.....	90	1.11	90	1.05	96	1.00	70	76	60	62	85	1.02
Wheat, per bush....	63	66	61	66	59	54	53	24	27	29	61	64
Corn, shelled, per bu.	63	73	72	78	69	70	70		50	50	75	75
Rye, do.....	38	43½	40	46	38	40	18	21	25	43	45	45
Oats, do.....	64	66		75	67	70			40	50		
Barley, do.....			9 a 11 per lb.			5.50	12½ per lb.		4.00	4.25		4.12½
Clover seed, do.....	16.13	per ce.			2.25	3.00	2.25	1.50	2.50		2.75	3.00
Timothy seed, do.....	1.20	1.30	1.20	1.25	1.25	1.50	1.00		1.00		1.25	1.30
Flaxseed, do.....	13.00	14.00	13.50	14.50	12.00	15.00			8.00	15.00		
Hay, per ton.....	30	43	31	46	30	40	30	40	26	30		
Wood, per lb.....					4.00	4.50	3.25	5.00				
Wood, hard, per cord												

CONTENTS OF THIS NUMBER.

Observations on the Growth and Nourishment of Plants, 169
 Mixing Soils and Manures,..... 171
 Plowing in Green Crops,..... 173
 The Fattening Qualities of different Breeds of Sheep,.... 176
 CONDENSED CORRESPONDENCE.—Salt vs. Fire; Sheep
 Frauds; Ruta Bagu and Mangel Wurzel,..... 178
 Growing Melons; Sweet Potatoes,..... 179
 Gapes in Chickens,..... 180
 Homes for the Poor,..... 181
 Soiling Cattle in Summer,..... 183
 Hungarian Cattle,..... 184
 Cast Iron Enamelled Stable-Fittings,..... 184
 LADIES' DEPARTMENT—Golden Bartonia,..... 191
 Treatment of Annuals,..... 191
 EDROE'S TABLE—Remarks on the Management of the
 N. Y. State Ag. Society; Tobacco; Notices; &c.,... 193
 Inquiries and Answers,..... 194

HORTICULTURAL DEPARTMENT.

The Propagation and Culture of Fruit Trees, &c.,..... 185
 Rustic Work in Gardens,..... 186
 Brown's Patent Fumigator,..... 187
 Hints for June,..... 188
 Easter Beurre Pear,..... 189
 Machine for Cutting Grass Plots,..... 190
 Genesee Valley Horticultural Society,..... 190

ILLUSTRATIONS.

Hungarian Cattle,..... 184
 Stable-Fittings,..... 184
 Rustic Basket,..... 187
 Brown's Patent Fumigator,..... 187
 Easter Beurre Pear,..... 189
 Patent Grass-Cutter,..... 190

ADVERTISEMENTS, to secure insertion in the Farmer, must be received as early as the 10th of the previous month, and be of such a character as to be of interest to farmers. We publish no other. TERMS—\$2.00 for every hundred words, each insertion, paid in advance.

Improved Stock.

CATTLE of the Durham, Devon, Hereford, Alderney, and Ayrshire breeds.

SHEEP of the Native and French Merino, Saxony, South Down, and Cotswold.

PIGS of the Lincoln, Suffolk, and Berkshire breeds.

From our long experience as breeders and dealers in the above kinds of stock, and our excellent situation for purchasing and shipping, we think we can do as good justice to orders, as any other house in the United States.

A. B. ALLEN & CO.,

April 1, 1852—tf 189 and 191 Water st., New York.

Clover and Timothy Seed.

NOW on hand and for sale at the Genesee Seed Store and Agricultural Warehouse, 63 and 65 Buffalo St. 500 bushels good Timothy Seed. 200 " prime Clover. Rochester, April, 1852. J. RAPALJE & CO.

Potatoes for Seed.

1000 bushels *White Mexican Potatoes*, an excellent potato, yielding first rate and never rotting. It is the favorite here. Price, \$1 per barrel.

Also, 100 bushels of the *Mexican Potato*—the very best potato in existence for the table, so pronounced by all who have tested them.

Those who wish either of these kinds must apply soon, as they are going off with a rush. Rochester, N. Y., May, 1852. J. RAPALJE & CO.

Young Morgan Tiger

WILL stand the coming season at the stable of Aaron Miller, two miles southwest from Lodi, Seneca Co. Terms of insurance, \$10.

This *justly celebrated Horse* has been owned and kept by J. M. Gillel, of Wayne Co., three seasons—took *First Premium* at Wayne County Fair in 1850, and certificate of *Best Horse* exhibited 1851. His colts, one an 1 two years old, took First Premiums at the State Fair in 1851. Pasture at reasonable charge. MILLER & SWARTHOUT. Lodi, May, 1852.—4-11*

The Practical and Scientific Farmer's own Paper.

THE GENESEE FARMER,

A MONTHLY JOURNAL OF

AGRICULTURE AND HORTICULTURE,

ILLUSTRATED WITH NUMEROUS ENGRAVINGS OF Farm Buildings, Domestic Animals, Implements, &c.

VOLUME XIII, FOR 1852.

DANIEL LEE & JAMES VICK, JR., Editors.

P. BARRY, Conductor of Horticultural Department.

Fifty Cents a Year, in Advance.

Five Copies for \$2—Eight Copies for \$3, and any larger number at the same rate.

All subscriptions to commence with the year, and the entire volume supplied to all subscribers.

Subscription money, if properly enclosed, may be sent (post-paid or free) at the risk of the Publisher. Address to

DANIEL LEE,

Rochester, N. Y.

December, 1851.

POSTAGE on THE GENESEE FARMER.—50 miles or under, five cents per year; exceeding 50 miles and not over 300, ten cents; exceeding 300 and not over 1000, fifteen cents; exceeding 1000 and not over 2000, twenty cents; exceeding 2000 and not over 4000, twenty-five cents; for any distance exceeding 4000, thirty cents.

STEREOTYPED BY J. W. BROWN, ROCHESTER, N. Y.

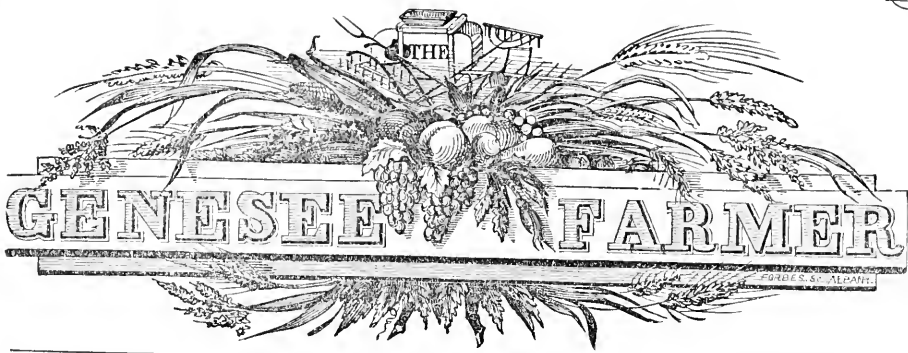

VOL. XIII.

ROCHESTER, N. Y., JULY, 1852.

No. VII.

SUGGESTIONS ADDRESSED TO STATE AND COUNTY AGRICULTURAL SOCIETIES.

NEXT in importance to the organization of efficient State and County Agricultural Societies, is their union on just and liberal terms, in a way that will bring the strength of the whole to bear on the advancement of agriculture in a concentrated form. Hitherto the friends of improvement have so divided and sub-divided their moral force, and diluted what little enthusiasm exists in behalf of agricultural education, that both have signally failed to realize the wishes and hopes of those that believe in human progress. Other means, and more extended combinations must be brought into requisition, before the twenty-five millions of souls in this great Republic can be made to appreciate the dignity and importance of scientific agriculture. It is folly to expect a steam engine of ten-horse power to do the work that can only be performed by one of ten times that force. Local Societies for the promotion of agriculture are confessedly valuable; but let them unite their present comparatively inefficient efforts, and vast results may speedily be achieved now wholly unattainable. It was the federal union of the thirteen isolated colonies that created eighteen new State sovereignties and five Territories under the American flag. It would be easy to name thirteen State Agricultural Societies that now suffer from the weakness of colonial isolation and dependence, which, if united, would help each other, and thereby command all the assistance from popular sympathy and legislation that agriculture deserves.

Will State and County Societies combine to strengthen themselves, under any name or form? This is just now the grand question in the current history of rural affairs in this country. In some States and Counties, and we trust in a majority, public intelligence is sufficiently advanced for a general and cordial co-operative movement. By and between all such Societies let there be no more repulsion, but a speedy and hopeful union to promote a common cause. In prosecuting the most destructive wars, the science of combinations has been carried to great lengths; and in modern times, victory has rarely failed to perch on the banner of the army whose combinations were the most perfect. Can no science, nor patriotism, nor the love of honorable distinction, bring out into the field of improved husbandry the millions of farmers in the United States? A short war usually costs many millions of dollars and many valuable lives, and military glory has ever been the most popular in the world. To the friends of peace this lesson teaches the wonderful power of combinations, and suggests the propriety of having banners and music at cattle shows and fairs, to render them more attractive to those who are governed mainly by the outward senses. Take mankind precisely as they are, and then convert them into subscribers to agricultural journals, into members of rural associations for mutual instruction and improvement, and into earnest co-laborers in the

support of National and State Agricultural Societies. These institutions can be made extremely useful; but they need watching—need popular sympathy—need generous support.

Congress publishes 130,000 volumes a year of agricultural books for general distribution. By placing this branch of business under the direction of the executive officers of a National Society, acting as the federal head of State and County Societies, an annual report on the agriculture of the United States might be gotten up far more useful and creditable than that now published, and for less money; and the books might go directly into the hands of State and County Societies, for distribution where they will do most good. In this way the General Government would aid in sustaining, and in the creation of new local Societies, over the whole Union, devoted to the improvement of tillage and husbandry. Suppose there were in our thirty-one States and five Territories, one thousand Societies, and that a National Board should distribute only 100,000 volumes a year. Let these books be of the most reliable authority in rural arts and sciences, and properly adapted to the various soils, climates, and circumstances of American farmers, and the one hundred new volumes which each Society received every year would render both the Society and the community where it labored, an invaluable service. This arrangement would give members of Congress 30,000 volumes for personal distribution; and if properly made, they would be worth more than the whole 130,000 now are. We think that it needs no argument to satisfy most readers, that politicians are not the best men to control the production of books relating to agriculture. The work in all its details should be in the hands, not of government, but of a National Board or Society, appointed by State Boards or Societies. We insist on the point that, something should be done to give the latter a little more means for doing good, and greater dignity and consequence in a nation of farmers. State and County Societies have the power to induce Congress, which now expends over fifty millions of dollars a year, drawn mostly from the soil, to do something for State associations. The officers and members of these Societies have only to unite their influence to carry any reasonable measure. Isolation has ever been the bane of agricultural progress. Nothing can be gained without concert of action, harmony, and perseverance.

What may be the result of the National Agricultural Convention to assemble in Washington on the 24th of June instant, (we write on the 5th,) we know not; but from the high character of the gentlemen who make the call, we anticipate a favorable issue. Everything, however, depends on the friends of improvement in the several States. If they desire to increase their intercourse with each other, and with the leading friends of agriculture in Europe, they will associate for such and other kindred purposes under a national organization. So great are the facilities for international exchanges of rural knowledge, of seeds, fruits, cuttings, and domestic animals, that the best in the world will come to the door of every farmer, if he will only make a little personal and associated effort in that behalf. Three millions of cultivators and freemen, *united*, may do anything and everything that ought to be done. Sustain, then, all existing agricultural Societies, and found new ones wherever needed.

SALT YOUR HAY.—It is a first rate practice to scatter a little salt on every layer of hay or clover when you are stacking it. Those who have never done so can scarcely imagine the avidity with which horses and cattle eat the salted in preference to the unsalted hay. Especially would we recommend the practice in bad seasons, and in stacking damaged, or low, wet, meadow hay. It retards fermentation, and imparts such a relish that cattle sometimes prefer it to good, well cured hay. We have often used it at the rate of four quarts to the ton, and have derived much benefit from so doing. Try it.

THE PHILOSOPHY OF NUTRITION.

PLANTS derive all the elements that enter into their composition either from the soil or the atmosphere, — they take them up in solution in an elementary or simple form, and convert them into compound substances; and it is these compound substances that form the food of animals — the simple elements of them, though given in exactly the same proportion as found in plants, would not only be non-nutritious, but *poisonous*. Nothing but what possesses organization can sustain animal life.

The organic or nutritious matter of all plants consists of oxygen, hydrogen, nitrogen, and carbon; these four elements compose about 95 per cent. of all animals and plants. The most nutritious food and the most virulent poison are alike composed of these elements, varying only in proportions.

Chemists divide the compounds of plants and animals into two great classes — the *nitrogenous*, or substances containing nitrogen combined with the other three elements; and the *non-nitrogenous*, or substances composed only of oxygen, hydrogen, and carbon.

Everything possessing life or organization, contains *nitrogen*. The flesh, brains, muscles, tissues, &c., of the animal organism, are all *nitrogenous*; while the fat is *non-nitrogenous*. The gluten of wheat is *nitrogenous*, and *identical in composition* with the pure flesh of the animal. Starch is *non-nitrogenous*, and corresponds with fat. There is in all plants a *nitrogenous* compound almost identical in composition with the gluten of wheat, the albumen of an egg, the casein of cheese, &c., the composition of which, as we have said, is precisely similar to that of the fibrine, &c., of the animal. Now, these *nitrogenous* substances are the real sources of nutrition; they are similar in composition to the white and yolk of an egg, which we have only to expose to a certain temperature for three weeks, when, under the influence of its principle of vitality, we obtain bones, sinews, muscles, claws, beak, eyes, feathers, nerves, lungs, liver, intestines, and the various other parts of the animal economy. All these products come from these apparently simple substances merely by the action of the principle of vitality. In like manner, when these vegetable or animal substances get into the animal system, and are operated upon by the vital functions, they are dissolved and distributed through the various parts, to form the different bodily organs required by the necessity of the animal; and it is impossible to imagine that these materials agreeing in their composition with the flesh, &c., of the animal, can be changed at all in composition when taken into the system — that they can, when there, receive any addition either of carbon or nitrogen. We have no doubt whatever, that vegetables produce the flesh of animals, and that the animals dissolve the already prepared matters, and under the action of vitality give them a different mechanical form, and put them on the muscles of the body. There is no reason to believe that the stomach of the animal acts upon these matters in any other way than by solution, the vital force afterwards putting each particle in its proper place in the system.

The *non-nitrogenous* elements, or the starch, fat, oil, gum, sugar, &c., are also necessary as food for animals — not to build up or repair the different parts of the organism, but to keep up animal heat, and to enable the animal to lay on fat. They are often very properly termed the *respiratory* or *fat-forming* principles, and many persons have supposed that the relative value of certain foods for fattening purposes was in direct proportion to the amount of these heat-producing, fat-forming substances. This, however, is not correct; or at least is not borne out by any of the numerous experiments that have been made in reference to this point. The fact is, that the *non-nitrogenous* substances are much more plentiful in all our cultivated grains and grasses, than the *nitrogenous*: and it would appear that however liberally an animal may be supplied with *non-nitrogenous* substances, yet if there is not a corresponding supply of *nitrogenous*

matter, little fat will be produced; so that it may be laid down as a rule, other things being equal, that the more nitrogen a food contains, the greater is its value as food for animals. If an animal were fed on non-nitrogenous substances alone—upon fat, oil, starch, gum, or sugar—it would be perfectly impossible for it to grow, to work, or to live. Arrow-root, starch, and all other things of that kind, by themselves, are insufficient to sustain life,—they may do very well to produce animal heat, but it would be perfectly impossible to live on them alone; they must be united with other material containing nitrogen, which alone can supply the daily waste of the muscles. Every motion which an animal makes with any muscle, causes a proportionate destruction of that muscle. At the time he makes the motion, the oxygen attacks the muscle and dissolves a portion of it equivalent to the amount of motion and force produced. This is a method of obtaining animal heat which is independent of the non-nitrogenous matters supplied in the food, the carbon and hydrogen of the muscles being used for this purpose, while the nitrogen is separated from the blood by the kidneys, and thrown out of the system in a liquid form.

From these facts it is evident that both rest and warmth are necessary for an animal's increase and proper development. In fattening an animal for the butcher, we of course do not wish a constant and rapid transformation of the muscles of the body, which is the case if the animal takes much exercise. Neither do we wish the fat-forming principles of the food used, to produce unnecessary heat; for as it must necessarily consume a certain amount of the elements of respiration in order to produce heat, and as fat can only be laid on in proportion to what remains after this necessary production of animal heat, it is quite clear that fattening animals should always be so sheltered as to be enabled to use the elements of respiration which are found in their food, so as to produce the best possible effect: and as every motion of the animal produces a corresponding destruction of the muscles, it is quite clear that the more animals move about, the more of the elements of nutrition will they require to supply what has been wasted. Therefore, in fattening animals, they should be allowed no more exercise than is absolutely necessary for health, and be kept comfortably warm. It is known that animals often asleep gain more flesh than others which are more wakeful; and that if they are kept in a dark place, they are more disposed to be drowsy, and consequently to lay on fat, than if exposed to the light. We must not, however, treat rearing animals in the same way as the fattening ones. We want the former to have a good constitution, and to increase their muscles and general size; and this can only be secured by giving them a considerable amount of exercise in the open air, and giving them as much food of a nutritious kind as they can eat.

The effect of common salt on fattening animals is not generally understood. Salt is composed of chlorine and sodium. The bile of an animal is a sort of carbonaceous, resinous compound, held in solution by soda. The effect of salt is to enable the animal to form bile; without it in the food, no bile could be formed, and bile is necessary to the healthy action of the animal functions. But mark—any means which produces an excess of bile, is merely robbing an animal of a portion of its food, and preventing the formation of a quantity of fat; because the bile is formed of fat, oil, gum, sugar, &c., and really represents and embodies the carbonaceous materials destined for immediate consumption. The more bile we produce, the less fat we produce; and the more salt we give animals, the more bile we allow them to produce. A cow eats about four ounces of salt in her food per day, which is contained in the saline ingredients of the food itself, and would appear to be sufficient for bile-forming purposes. For growing stock, salt may often be an advantage, benefitting their health and increasing their appetite; but we doubt the economy of giving salt to fattening stock.

On the subject of cooking food for animals there is much diversity of opinion, some condemning it altogether, while others have exaggerated ideas of its value. If nutritive

and useful materials exist in certain kinds of food, cooking can only be useful by aiding their solubility. It can make them more soluble, and on that account probably a less amount of food will pass through the system undigested. No one supposes that if we were to cook sawdust for any length of time, we should make it good food; those parts of the substance which are indissoluble, and which consist of woody matter, would still remain so; but the other parts, such as starch, gum, oil, &c., would be made soluble in water, and consequently could be more easily assimilated by the animal. But it is important that these things be not carried too far. We know very well that the functions of digestion are very important, nor are they so simple as some imagine. There are more processes than one going on, and there are a great many things to be considered. If the requisite amount of saliva be not swallowed, it may cause a great defect in an important element of health; and if animals swallow their food too quickly, they will probably not have sufficient saliva for digestion. We need more light on this, as on almost every other agricultural subject.

CUTTING FOOD FOR STOCK.

It is generally admitted to be good economy to cut hay for cattle, if it is of an inferior quality, much less being wasted by the animal; and it affords an excellent opportunity of mixing meal or shorts with it, by way of seasoning, making it more palatable as well as more nutritious. But many farmers have their doubts whether it pays to cut good hay—whether much benefit is derived from the operation in the way of rendering it more easy of digestion, &c. With a view to settle the question, the Worcester Agricultural Society offered two premiums, of \$30 and \$20, for the best experiments on the subject, laying down the rules according to which the experiments should be conducted, which were briefly as follows:

“The trial to be made with at least two animals, as near alike in condition, age, &c., as possible, the time of trial to last at least eight weeks, divided into periods of two weeks each. One animal to be fed with cut while the other is fed with uncut hay; the feed of each to be reversed at the expiration of two weeks, and so on alternately each two weeks, during the trial. If any other food except hay be given, (such as roots or meal,) the same quantity to be given to each, that the result in relation to the cutting the hay be not affected by other food. The animals to be kept in the same stable, and at the same temperature. Each animal to be weighed at the commencement of each two weeks, and at the close of the experiment. The same kind of hay (what is usually called English hay) to be used during the whole time. The time of giving food and drink to be regular, and also of milking. The time of weighing to be in the morning, and before the animal has been allowed to drink.”

There were four competitors for the premiums—Messrs. DEMOND, DODGE, LINCOLN, and HAWES.

Mr. DEMOND's experiments were on two cows, seven years old, dried off the 10th of December, 1851. The experiment commenced Jan. 1, 1852, and lasted eight weeks. In addition to the hay, each cow was allowed a half peck of turneps per day, or seven bushels to each cow during the experiment, which are considered equivalent to 58 lbs. of hay.

Mr. DODGE's experiments were with two steers, both three years old this spring. Trial commenced 3d of Jan., 1852, and continued eight weeks. Each steer, in addition to the hay, was given two quarts of meal per day, which is equivalent to 293 lbs. of hay for each steer during the eight weeks.

Mr. LINCOLN's experiments were with two milk cows, four years old each; one calved the 14th and the other the 20th of June, 1851. Trial commenced 9th of Jan., 1852. In addition to the hay, each cow eat 648 lbs. of carrots, equivalent to 171 lbs. of hay.

Mr. HAWES' experiments were on two working oxen, seven years old each this spring.

Trial commenced 15th Dec., 1851. The cattle being kept pretty regularly at hard work during the whole eight weeks of the experiment. They were allowed nothing but hay.

The following table will show the final results of the experiments :

	C. B. DEMOND. Dry Cows.		HARVEY DODGE. Steers.		W. S. LINCOLN. Milk Cows.			A. H. HAWES. Working Oxen.	
	Weight of hay consumed in 8 weeks.	Gain in weight of animal during 8 weeks.	Weight of hay consumed in 8 weeks.	Gain in weight of animal during 8 weeks.	Weight of hay consumed in 8 weeks.	Gain in weight of animal during 8 weeks.	Milk yielded in 8 weeks.	Weight of hay consumed in 8 weeks.	Gain in weight of animal during eight weeks.
Cut	lbs. 1171	lbs. 64	lbs. 916	lbs. 80	lbs. 1150	lbs. 120	lbs. 438	lbs. 2106	lbs. 137
Uncut	1149	56	946	60	1130	30	417	2106	93
Mean weight of animal,	892 lbs.		1110 lbs.		900 lbs.			1567 lbs.	

It is seen that in every one of the experiments there is a greater increase of animal from the cut than from the uncut hay ; the difference in the quantity of milk is small, but in favor of the cut food. It is, in our opinion, to be regretted that the same animal was not kept on the same food during the whole length of the experiment, and not have changed them every two weeks ; for in such a short period it is very doubtful if the scales will at all indicate correctly the actual gain in fat or flesh of the animal. There is no doubt, however, but what the experiments were conducted with great care and accuracy, and the results are so uniform as to confirm the opinion of those who think it good economy to cut even *good* hay. Mr. HAWES makes the following remarks in his statement to the committee :

"A great advantage in cutting hay at least for working stock, was very obvious during the whole of this experiment ; before the ox feeding on uncut hay had gotten one half through with his allowance, the ox which had cut feed had eaten up what was given him and was laying down taking his rest ; and this, at noon when but little time is allowed for eating and rest, must be an advantage of no small importance."

Mr. W. S. LINCOLN says :

"Some time before commencing this experiment, I was feeding to my stock what would be called poor stock hay, with an allowance of roots. I commenced cutting this hay for all my stock, young and old, (16 head,) occupying me about an hour and a half daily. Almost simultaneously with feeding the cut hay was an increase of milk, very perceptible as it was milked in the pail. From day to day the milk increased so, from the stock I have described, as to require the substitution of six quart for four quart pans, which had been previously used. I think I am within bounds in saying the increase was over a pint daily per cow, occasioned, to the best of my knowledge, solely by the use of cut hay."

The first premium was awarded to Mr. LINCOLN, and the second to Mr. HAWES.

SOOT AS A FERTILIZER.

A STATEMENT has lately been extensively circulated by the agricultural press, respecting a recent discovery by Dr. PENNY, in Scotland, who found a very large quantity of potash in some soot taken from a *blast* iron-furnace flue, amounting to about 50 per cent. of carbonate and sulphate of potash ; and it is thought that this kind of soot will soon be extensively used for the manufacture of these important and expensive salts. The mineral theory advocates, or those who assert that the only elements that are needed by plants are those of a mineral nature—such as potash, soda, phosphate of lime, silicates, or the ash constituents of the plants to be grown,—and that the crops on a field increase or diminish as these are withheld or supplied, independently of organic matter, have

seized upon this discovery as one that affords strong evidence of a practical nature that their theory is correct: hence they exultingly say, "Here, in this discovery, we have the cause explained of the well known value of soot for agricultural purposes."

It is a "well known" fact that soot is of great value for agricultural purposes; especially is it found a valuable manure for wheat and other cereals, and sells for this purpose in the English towns at from twelve to twenty cents per bushel. Dr. ANDERSON says of it: "I have used soot as a top-dressing for clover and rye grass, in all proportions from one hundred bushels per acre to six hundred, and I can not say that I ever could perceive the clover in the least degree more luxuriant than in the places where no soot had been applied; but upon rye grass its effects are amazing, and increase in proportion to the quantity, so far as my trials have gone." And his general conclusion is, "*that soot does not affect the growth of clover in any way, while it wonderfully promotes that of rye grass.*"

But we need not quote experiments, for it is universally admitted to be a most powerful and efficacious manure for all *cereal* crops. And this fact,—if it were true that the soot generally used for agricultural purposes contained 40 per cent. of potash—would indeed be a most potent argument in favor of the mineral theory; but this is not the case. A sample of soot analyzed by M. BRACONNOR, taken from a chimney where wood had been the fuel, was found to contain the following ingredients:

Umic acid,.....	30.0
Nitrogenous matter, soluble in water,.....	20.0
Insoluble carbonated matter,.....	3.9
Silica,.....	1.0
Carbonate of lime,.....	14.7
Carbonate of magnesia, (traces of)	
Sulphate of lime,.....	0.5
Ferruginous phosphate of lime,.....	1.5
Chloride of potassium,.....	0.4
Acetate of potash,.....	4.1
Acetate of lime,.....	5.7
Acetate of magnesia,.....	0.5
Acetate of iron, (traces of)	
Acetate of ammonia,.....	0.2
An acrid and bitter element,.....	0.5
Water,.....	12.5
	100.0

This analysis is also confirmed by M. PAYEN and M. BOUSSINGAULT. The latter, speaking of the soot from coal, says: "The superior qualities of coal soot are evidently due to two causes: first, it is more dense than wood soot, and in a given bulk actually contains a greater amount of matter. Secondly, I have found that for equal weights *coal soot contains the larger quantity of nitrogen.*"

There can, we think, be little doubt that the good effects of soot as a manure are owing to the large amount of nitrogen and ammonia it generally contains. There is, however, a difference in the composition of soot, owing, it is thought, principally to the draught and the height of the chimney—the soot from a high chimney being considered the best, and it actually sells for half as much again as the soot from a low chimney. Is not this owing to the fact that the inorganic matter (the potash, lime, soda, &c.) is merely carried up the chimney mechanically by the draught, and settles much sooner on the sides of the chimney than the organic matter, (nitrogen, &c.) so that the higher the chimney the richer would be the soot in nitrogen, and the more valuable?

The analysis of Dr. PENNY is doubtless correct, but it by no means represents the composition of the soot generally used for agricultural purposes. The intense heat and draught (an immense pair of bellows worked by a steam engine is usually employed to create the blast) probably sublimates the potash, and the draught carries it up the chimney, where it would lodge on any protuberance; and the position in which the soot examined by Dr. PENNY was found favors this idea.

Soot may be used with great benefit for wheat, either as a top-dressing or plowed under, at the rate of thirty bushels per acre. We prefer using it in the fall, which is indeed the best time to sow guano, sulphate of ammonia, or in fact any manure for the wheat crop. It gives the plant a strong and vigorous growth in the fall, and enables it much better to stand the winter, while on good strong soils there is little danger of much of the fertilizing matter being washed out by the rains, except where water is allowed to stand for considerable time. It has been recommended by some, to mix unleached ashes or lime with the soot previous to sowing: but this is a bad practice; for either of them will set free the ammonia, which escapes into the atmosphere, and leaves the mixture comparatively valueless as a manure for wheat.

MANAGEMENT OF BARN-YARD MANURE.

At the present day, no subject connected with agriculture is receiving so much attention, and deservedly so, as that of *artificial* manures—substances manufactured, or brought from a great distance at much cost,—while the manufacture of guano at home, in the barn-yard, is either altogether neglected or imperfectly attended to; and while we are far from wishing our farmers not to purchase artificial or manufactured manures, we think—we are sure—it would be greatly to their interest, to know more about the composition of the manure of the hog-pen, the horse-barn, &c., and the *reason* of its beneficial action on *all* soils.

On this subject there is great diversity of opinion among scientific men, and also among the farmers themselves. Some farmers assert that manure is not worth the expense of hauling and spreading on the soil, while others think it is never applied but with benefit to the subsequent crops. There is doubtless a reason for this difference of opinion. The former was probably formed by drawing on the land a substance *resembling* good, rich manure—made perhaps by cattle eating nothing but straw, and allowed to remain in the yard till all that was soluble was washed out of it, and what little ammonia it at first possessed evaporated into the atmosphere. We agree with the farmer who thinks such a manure hardly worth the labor of drawing out; at the same time we think that manure “as is manure” is never used without great benefit. We once more assert—and shall continue to repeat it till disproved, or farmers *act upon it*—that the composition and value of all manure depends, not on the animals making it, but on the composition of *the food consumed*—that the more nitrogen the food contains, the more *ammonia* there will be in the manure, and the more valuable will it be to apply to all the cereal crops.

Some farmers who understand this, and keep their stock on proper food, manage the manure they make so wretchedly that its value is lessened in many instances one-half. Then, again, some let the liquid excrements of the animals (and they are by far the most valuable, containing all the alkaline phosphates and nine-tenths of the ammonia,) run to waste, and are thus not only lost to the farm, but fill the atmosphere with gases injurious to animal life.

To prevent these losses, should be the great aim of the scientific farmer. The buildings should all be spouted, and the water not be allowed to run on the manure except at the discretion of the farmer, if this is done, there is sufficient waste straw on the farm to absorb all the urine made. The next precaution will be not to let the horse dung remain in a loose heap, close to the stable door, sweating and fuming, sending off all its ammonia, the most valuable ingredient, into the atmosphere; but it should be mixed with the cold and sluggish hog and cow manure, which would prevent a too rapid fermentation and the loss of so much ammonia. Compression, by excluding the air, will

also check decomposition. Yet it is desirable that the manure should ferment, and the bulk and weight be considerably reduced, without losing any of its elements of fertility. This can be done by preventing leaching and the evaporation of ammonia. The latter is a somewhat difficult operation, and various plans have been recommended without much success. Sulphate of lime, or plaster, when dissolved in water, will decompose carbonate of ammonia, the sulphuric acid of the lime uniting with the ammonia, forming sulphate of ammonia, while the carbonic acid attaches itself to the lime, forming carbonate of lime; and as sulphate of ammonia is an involatile salt, and of great value as a manure, sulphate of lime has been repeatedly recommended for this purpose. But it will only act in this way when in solution; and as it requires 460 lbs. water to dissolve one pound of sulphate of lime, its beneficial effect is very limited, and it can only be recommended as useful to fix the ammonia in cess-pools, sewers, and other liquid manure, and not to scatter on the surface of fermenting horse dung, &c. Sulphuric acid in a pure state, mixed with water, has also been recommended; and the acid undoubtedly will "fix" the ammonia already formed in the manure; but as it will check any further decomposition, it cannot be recommended. Superphosphate of lime has been used for this purpose with the most complete success. Scattered under the horses, or upon a fermenting manure heap, it immediately prevents the escape of ammonia. The high price of the article, however, is against its economic use for this purpose; yet if farmers would only save all the bones in the neighborhood, and learn how to manufacture the superphosphate themselves, it would be found the cheapest and best of all ammoniacal fixers. Finely pulverized clay is a great absorbent of ammonia, and the covering the manure heap with a loam containing considerable clay, would retain a greater part if not all the ammonia, if decomposition was not allowed to proceed rapidly.

CHEESE-MAKING FROM A SMALL DAIRY.

WE have received requests from several of our lady correspondents, to write a short article on cheese-making especially in reference to that large class of farmers who keep but few cows. It always gives us pleasure to comply with the requests of the ladies, especially of those who are good house-keepers—know how to milk a cow, make good butter and cheese, and cultivate a small flower-garden.

First rate cheese can be made from a few cows, but it is attended with more labor in proportion to the amount made, than in a large dairy, inasmuch as the curd has to be made every morning and placed aside till you have sufficient to make a good sized cheese. The milk is placed in a tub, and warmed to the proper temperature (95 deg. Fahr., or about as warm as when taken from the cow,) by adding a portion of heated milk. The rennet is then added, the milk well stirred, and afterwards let alone till the curd is well come. The time this occupies varies from fifteen minutes to two hours, according to the amount of rennet, the temperature, &c.—the hotter it is put together, and the more rennet there is added, the quicker will the cheese come. As a general thing, the longer it is in coming, the tenderer and sweeter will be the curd. If it comes too quickly, it is owing to an excess of lactic acid being formed from the sugar of milk, so that the curd has that hard, tough, white appearance that is the case when the curd is precipitated by vinegar, or any other acid; but if there is a very slow formation of lactic acid, the curd is gradually precipitated in flocks, is less dense, and very sweet and tender. It is then broken up quite fine, either by hand or a curd-breaker made for the purpose, which cuts it into very small pieces. After this it is allowed to stand and settle. The whey is then drawn off and passed through a sieve, to remove any curd there may be in it. The curd is then placed in a strong cloth, and well pressed, to

remove the whey. It is then placed in a cold place, and the operation repeated daily—or every other day, if the milk will keep sweet, as it will in the fall—till there is curd enough to make a cheese of the desired size. When the right quantity is obtained, the curd is all broken up very fine, salted, and well mixed. In putting the curd in the vat to be pressed, a cloth sufficiently large to cover the whole cheese is placed in the vat, and into this cloth the curd is put. When the curd has filled the vat, a “fillet,” (usually made of sheet tin, and from three to six inches wide, and sufficiently long to lap over four or five inches when placed round the cheese,) is placed inside the vat for an inch so, and the cloth drawn up straight, so that when being pressed the fillet will not cut it. The whole of the curd is then put in, the cloth turned over the top of it, a smooth board placed over this, and then it is ready to press. After it has been pressed for some time, it is taken from under, and punctured all over with a skewer, either of wood or iron. Place it in the press again till it has become sufficiently consolidated to take out of the vat without falling to pieces. It must then be turned, or inverted in the vat, and a clean cloth put round it. Place it again under the press, occasionally turning it and putting round it fresh cloths, till the cheese when pressed does not wet them. It is then all right, and should be kept in the dairy, or other cool, damp place, for a few days, placing a little salt round it, when it may be taken to an upper room, where it will require turning very frequently, or the side next the floor will mold. Let the room be dark and well ventilated. (See our remarks on *Butter and Cheese-Making*, in the May number, page 143.)

A cheese press may be purchased for about \$5; and the cost of the vats, fillets, &c., is very trifling; so that it is to us surprising that so few farmers with from four to ten cows ever make any cheese—not even enough for their own consumption. Good cheese sells for nearly as much as butter, and yet a cow will give, to say the least, as much again cheese as she will butter. It is true the whey is not so good to fat hogs as the sour milk, yet it contains much nutritive matter, and is a valuable food for shoats, or a good drink for fattening hogs; yet we think it would be more profitable to make cheese at the present relative prices of the two articles, than butter.

RUTA BAGA AND COMMON TURNIP CULTURE.

THOUGH roots as a class contain from 80 to 90 per cent. of water, yet it is generally conceded that more nutritive substance can be obtained per acre from them than from the cereal or leguminous plants; in fact, more than from any other plants cultivated. And this is not all; they are found by universal experience to be the best preparative for the wheat and barley crop; and when consumed on the soil, greatly increase the yield. Their cultivation is now just beginning to be adopted in this country, and we are much pleased to receive so many inquiries respecting the best method of preparing the soil, manures best adapted, &c., &c.

Ruta бага is probably the best root of the turnep class adapted to this climate; it is not so affected by drouth, and will stand the winter better than the common white or yellow turnep. The soil should be well pulverized and rich, and the seed drilled on ridges about twenty-seven inches apart, and when in the rough leaf the plants must be singled out with the hoe about a foot from each other, and kept clean. The first week in July will do to sow ruta бага, but they do better sown the middle of June. The present month, however, is the right time to sow the common turnep. These, though we prefer sowing them in drills the same as ruta бага, as they are then much easier to keep clean, admitting the use of the horse-hoe, will do sown broadcast, and will, if hand-hoed and kept clean, sometimes yield a much larger crop than when drilled.

We have seen a good crop of turneps that were sown after the wheat crop with one plowing, and sown broadcast at the rate of one pound of seed to the acre; but they were hand-hoed, costing about \$1.50 per acre: and we would say, as the result of some experience, that it is vain to expect a good crop of turneps, in nine cases out of ten, without hoeing them.

We would earnestly recommend the sowing of more root crops on the farm; and we believe that it would pay every farmer to sow five or six acres of the common turnep in the way we have recommended, after a wheat or barley crop. They could be eaten off on the land late in the fall by sheep, and the manure made by their consumption would be of great value to the following corn crop. It would even pay to sow the turneps after a grain crop, and let them rot on the land for manure. In this case they need not be hoed, and might be sown perhaps a little thicker. Their value in a system of rotation consists principally in collecting nitrogen from the atmosphere, which, whether allowed to rot on the land or consumed by stock and the manure returned to the soil, will be of great value to the subsequent crops. Indeed, it is to this artificial accumulation of nitrogen in the soil, by growing root crops, clover, and other leguminous plants, that we must look for an increase in our present yield of wheat, barley, corn, and other cereal crops.

A FEW WORDS ON GROWING CLOVER SEED.

The largest yield and best quality of clover seed is obtained by pasturing the first year's growth of clover till the last week in May, and then taking out the animals, destroying any Canada thistles, docks, May weed, &c., that may happen to be in the lot, thus insuring clean seed. It is, however, a more general practice to take a crop of clover hay first, and then allow the second growth to go to seed. In this case the first crop should be mown as early as possible; for the great difficulty in obtaining a large yield of clover seed is early frosts, which often check the growth of the clover before the seed is fully matured, and a small crop with an inferior quality of seed is the consequence. When the first crop is pastured or cut very early for hay, the second crop is of course much earlier, and the seed is elaborated perfectly under the influence of warm weather, while you have much better weather to gather in the crop. If, however, the crop is late, it may be allowed to stand as long as it will grow; for the frosts do not injure the vitality of the seed, but merely checks its growth. Three bushels of clean seed to the acre is about an average yield, though much larger crops are sometimes — and may be oftener — grown.

Clover being a leguminous plant, allowing it to go to seed does not impoverish the soil to that extent as do the cereal crops, which specially exhaust the soil of nitrogen, while clover obtains the large quantity of nitrogen which it contains from the atmosphere; so that by growing clover seed the soil is not materially impoverished or the following corn crop much injured.

We make these remarks in the hopes that they may induce farmers more generally to grow at least sufficient clover seed for their own use, believing that they will seed more land down to clover every year if they do so, than if they have to give their neighbors or city seed-store men four or five dollars per bushel for it, and *knowing* that the yield of wheat and corn crops will bear a pretty constant proportion to the amount of clover grown and used on the farm. If farmers would make it a rule, with exceptions only in uncommon cases, never to sow wheat or barley without in the spring seeding down the land with ten or twelve pounds of Red Clover seed per acre, the increased acreage yield of grain would much more than make up for the fewer number of acres sown; while the greater quantity of stock the land would thus be able to maintain, would greatly enhance the profits of the farmer.

THE PROPER TIME TO CUT WHEAT.

MUCH difference of opinion exists between purely theoretical and purely practical farmers, in regard to the proper time when wheat and other grain crops should be cut. The theoretical farmer says it should be cut while quite green—say fourteen days before it is ripe,—while most practical farmers think it should be quite ripe before cutting. The early cutting advocates advance not only a very plausible scientific reason for their opinion, but give numerous experiments which confirm the deductions of science. The arguments in favor of early cutting may briefly be stated thus: The grain and straw of wheat contain starch and sugar, a portion of which, if the grain is allowed to get quite ripe, is converted into woody fibre, or bran; while if cut green, these would remain unchanged in the grain, and the wheat would yield more flour of a superior quality with considerable less bran. Another reason is, that the straw when cut green is of much more value as food for cattle, containing starch and saccharine matter which if allowed to get fully ripe is changed into woody fibre, and its nutritive qualities greatly reduced; and then there is less loss by shelling when the crop is cut green than when fully ripe.

We think the true course lies between the two extremes; for while we would by no means cut wheat fourteen days before it is ripe, feeling satisfied from numerous practical experiments that there would be much shrinkage and a loss, (not perhaps to the miller, but to the farmer,) yet we would equally avoid letting the grain get fully ripe. As good a practical test as any we know, of the right time to cut wheat, is to take a kernel between the end of the finger and the thumb joint, squeeze it to a pulp, and if there is no milk or sap at all in the grain, all circulation and growth have ceased, the wheat derives no more nutriment from the soil, and will be better cut up than standing; the straw for an inch or two below the ear will be found to be white, and to have lost all its sap. And now, as the world-renowned reapers give the farmer the control of the harvest, he need not fear that a portion of it will get over-ripe before it can be harvested, and much be lost by shelling, as was formerly often the case where there was a large breadth of wheat to cut and cradlers could not be had at any price; therefore it is not necessary to commence operations till the grain is in a fit state for cutting.



WOODMAN, SPARE THAT TREE.—To those who live on the great prairies of the west, where every tree is a friend reminding them of a once loved but forsaken eastern home—a connecting link between the past and the present—I need not say *spare the trees*. There the noble tree is prized for its beauty, its shade, and its timber,—it is sought by the dweller on the prairie, like the “shadow of a great rock” by the way-worn eastern traveler. But those who make a new home on timbered land, where the trees are to be felled before they can raise the necessities of life, get a passion for the destruction of trees, looking upon them as their natural enemies, until they find, too late, that they have carried the war a little further than was necessary—even further than either profit or pleasure required. To those who are clearing land of timber I have a word to say—and I wish to say it just at the present season of the year, when nature puts forth all her beauty. After a few acres are cleared, requiring attention during summer, most of the chopping is done in the winter season, when the trees are not seen in their beauty, and scarcely one is spared. Let the farmer now look at the trees arrayed in all their beauty, when the green leaves are so beautifully green, their shade so grateful to every living creature, and resolve hereafter to spare a few trees on the road-side—a little grove in the corner of the field, and around his house,—and he will receive the grateful acknowledgements of his flocks and his herds, the thanks of his neighbors and all that pass by.

Condensed Correspondence.

HOW TO PREVENT CUCUMBERS FROM BEING DESTROYED BY THE STRIPED BUG.—I suppose there are very few persons who have raised, or attempted to raise cucumbers, who have not been annoyed by the above named insect. I have often had my entire planting destroyed by them within a few days after the plants appeared above ground—all preventives to the contrary notwithstanding. For a long time I have thought there was no remedy, save in the application of the *thumb screw*. This year, however, I have covered each hill with a box without top or bottom, the sides being eight or ten inches high, leaving two hills uncovered. The result is, the hills exposed are entirely destroyed, while the others have not been injured in the least and are flourishing finely. This method, doubtless, is known to many, and all who wish to raise cucumbers would find a great saving of vexation by putting it in practice. S. H. A.—*Canandaigua, N. Y.*

BEE ROT.—In the March number of the *Genesee Farmer*, page 100, D. G. FORT says he finds his bees affected with what he calls the "Bee Rot." Having had some experience as an apiarian for a number of years, and also noticed the same evil that he has described, I have uniformly found that my strongest and best swarms are most likely to be affected—feeble and late swarms always escaping.

The Cause.—I will give my views as to the cause, which, to me, is perfectly satisfactory. The fact that the swarms that in early spring are the greatest sufferers, I can attribute to no other cause than the result of a severe frost or a very cold night. The swarm being in a thriving condition, the Queen hastens to perform her office, depositing her eggs in the cells at first moderately, until the stock of working bees are to some extent increased, and then more rapidly; and being a little in advance of the season, and there not being bees enough hatched to produce a sufficient degree of heat, a cold night (or day) comes and the dire calamity befalls this thriving colony. And as all of the thriving swarms are not alike affected, I am led to infer the brood is more exposed to this malady at some stages than others, and the remedy would be comparatively easy if we knew which hive stood in need of it.

The Remedy.—By observing the weather a little, you will be able to determine when the remedy should be applied; all you want is to keep up a usual degree of heat in the hive. This may be done by placing straw or cloths around the hives, sufficient to produce the desired effect, and you have the remedy. J. D. C.—*Locke, N. Y.*

A Good Cow.—Believing for a year past that I had a cow possessing extraordinary qualities for milk and butter, I resolved on giving her a trial. Accordingly, on the morning of the 30th of November last, (the third week after calving) she was carefully milked, and her milk weighed and put in pans and kept alone with her name, "Devon," put on every pan so as to prevent the possibility of a mistake. This care was followed to the evening of December 6th, making seven days. Her yield of milk for each day was as follows:

First day, 53 lbs.; second day, 56 lbs.; third day, 64½ lbs.; fourth day, 54 lbs.; fifth day, 56 lbs.; sixth day, 56 lbs.; seventh day, 58 lbs.; total, 397½ lbs., in seven days, and measuring 46 gals., 3 qts., and 2-17 of a pint—making nearly 6 gals. and 3 qts. per day.

The butter, when thoroughly worked and ready for market, weighed, in the lump, 21 lbs. 10 oz., worth 25 cts. per lb.—\$5.40.

Her feed during the week of trial, was 1 qt. of cake meal, and 3 qts. of corn meal, weighing 5½ lbs., made into a mash, night and morning; at noon, 4 qts. of wheat bran, weighing 3 lbs., made into a slop with hot water, and given warm, and the same at night at 9 o'clock—making 17 lbs. of corn meal, cake meal, and wheat bran, united, for each 24 hours; or 119 lbs., neat weight, for the week, which was worth, at mill prices, \$1.28, or 18¾ cts. per day. The hay that she eat I suppose to be 150 lbs., (I did not weigh it) worth 75 cts., making cost of keeping, during the week, \$2.03.

The above cow appears to be part Devonshire, mixed, perhaps, with Ayrshire, of a red color, except her udder and a stripe under her belly, which are white. She is of a large size, (say five hundred,) of beautiful symmetry, and is about seven years old. She carries the French marks of about a fourth

rate cow—if I understand them. She gave as much milk last May and June, after having been milked eight months, as my fresh cows (say 5 gals. per day) that were making their 10 lbs. a week. She continued to give milk forty-four weeks in the year, although the pasture the latter part of the season was very poor—and she had nothing else. ISAAH MICHENER.—*Buckingham, Bucks Co., Pa.*

UNLEACHED ASHES ON POTATOES.—E. HAMMOND, of Schoharie Co., N. Y., stated in the April number of the Farmer that when unleached ashes were applied to potatoes, at the time of planting, "*wherever the ashes and the tuber came in contact there was rotteness in every instance.*" Unleached ashes will destroy any vegetable with which it comes in contact, and indeed almost any animal substance, and should never be applied directly to plants, or to the roots of trees, or so as to come in contact with the bark, unless in very small quantities. After the potash is abstracted by leaching, they are perfectly innocent and can be applied in almost any quantities. I have spread unleached ashes on the ground before plowing, and used them as a top-dressing before hoeing, and always believed myself well paid by an increased crop; though I am not able to say that so far as the rot is concerned, any effect was apparent. I have been long convinced that no crop destroys potash like potatoes. Some years ago, before I had engaged in farming, I purchased, near the city, half an acre of ground and planted it with peach trees. It was new land, potatoes having been raised on it only one year, and the crop stated to be 125 bushels. Thinking that potatoes would be the best crop for the trees, I planted them four years in succession. The first year I had 70 bush., good; the next year about 35 bush., and rather small; the next year I offered them to any one who would dig them, and failing in this they were never dug; the next year I put on about twenty-five loads of ashes, and the yield was eighty bushels. J. W.—*Brighton, N. Y.*

PATENT GALVANIZED IRON.—I have noticed of late numerous recommendations of "Patent Galvanized Iron" as an article of great importance to farmers, mechanics, builders, &c., &c. It is particularly recommended for Roofing, Wire Fencing, Telegraph Wire, Lightning Rods, Sheathing for Vessels, &c., and it is urged that it is a cheap and durable material for these and divers other purposes. With the limited knowledge which people generally possess of this article, there is great liability to be deceived by it, and I doubt not that the high expectations which may be formed of its value, for many of the purposes for which it is recommended, will be disappointed and much money will be uselessly expended upon it.

For wire fencing, it is probably no better than ordinary ungalvanized wire. When the coating gets rubbed off, as it inevitably will in places, the wire is supposed to corrode faster than it would had it never been coated. This is probably owing to the action of the acid used in galvanizing, upon the wire.

Galvanized wire has been used somewhat extensively in this country in the construction of telegraph lines, but for that purpose it is now thought to be less desirable than ordinary wire, and it is probable that no more of it will be put to that use. An enormous price has heretofore been charged for this article, notwithstanding the galvanizing is very cheaply and rapidly done. I would advise farmers and others to be well satisfied of its utility before paying a high price for it, or using it extensively. M.—*Rochester, N. Y.*

VIRGINIA LAND.—Having received several letters of inquiry from various persons, in reference to my article on "Virginia Lands," and finding myself unable to reply to so many, without neglecting the duties of my profession and attention to my farm, I beg leave to trouble you with a second, and final article on the subject in the Farmer. This will embrace, as far as practicable, a full reply to every question, as well as whatever else I think of interest.

1. *Soil—Productions.*—Every variety of soil abounds—the stiff, red clay, with a mixture of mica—a brown chocolate, *slaty*—the light grey, sandy, chinquepin—the *mulatto*—and pipe-clay soils, in some parts. A farmer of my acquaintance, who has travelled a good deal, particularly in the south and south-west, remarked to me not long since, "that he had never seen land better adapted to clover, or that improved more rapidly from the use of gypsum, than some of the land in this vicinity." I have several fields well set in clover, sown last spring, which have received no other help than a little gypsum, in which the seed was rolled. My soil is a light grey, sandy one, well adapted to the production of tobacco of the finest quality, such as, if properly managed, will bring \$30 per cwt.

The soil generally is well adapted to the growth of tobacco, corn, and oats; tolerably well to wheat, and might produce it *very* well if proper attention was paid to its cultivation. Most time and care being devoted to tobacco, the land is never manured for other products. Maize is hastily planted

in April, and hurriedly worked over two or three times, and then "laid by" until ripe. Yield, from ten to fifty bushels per acre. Wheat is generally sown on the tobacco lots after the tobacco is housed. Usual time for sowing, from the 20th of October to Christmas. Oats are sown in the spring on the corn land of the preceding year. Rye and buckwheat are grown by but few; they now succeed very well.

Wheat is now worth 80 cts; corn, from 80 cts. to \$1; rye, 75 cts.; oats, 50 cts. The high price of the three last are owing to last year's drouth. Average prices, for wheat, from 75 cts. to \$1.25 per bu.; rye and corn, 40 cts. to \$1; oats, 25 cts. to 50 cts.; tobacco, \$5 to \$50 per cwt.; field peas, 75 cts. to \$1 per bu.; onions, \$2 to \$4; Irish and sweet potatoes, 50 cts. to \$1; clover seed, \$4 to \$5; dried apples and peaches, \$1 to \$2.

These, with some few cattle and horses, are our principal staples and subjects for sale in market. Our Market towns are, Danville, in this county; Richmond, 120 miles distant; Lynchburg, 40 miles; and Petersburg, Farmville, and Clarkesville, from 50 to 60 miles distant. These places are becoming more and more accessible by means of railroads and canals, made and being made, through this part of the State. The Richmond and Danville Railroad is in process of rapid erection, and passes through this county. The Virginia and Tennessee Railroad, commencing at Lynchburg and extending to the State line, passes through the adjoining county, Bedford. The James River and Kenahwa canal, commencing at Richmond, extends 40 miles above Lynchburg. And finally, there is a Bill before the Legislature, with every prospect of being passed, for a Plank Road from Pittsylvania C. H. to Lynchburg, 55 miles. Thus, the facilities of getting to market, though somewhat limited now, will soon be such as to enhance the value of lands, and add much to the resources of the country.

The easiest and most direct route to this county from New York, is by Baltimore and Washington to Richmond, thence up James River; or, by land, on the railroad and by stages.

Fruits of various kinds grow well, and people are beginning to pay much attention to the culture and propagation of improved stocks. Peaches, of fine qualities, and their kindred, grow in great abundance, and without much attention; while apples, pears, &c., require attention to succeed well. The vine succeeds admirably, though no one has yet turned his attention to making wine. Currants, gooseberries, raspberries, and strawberries, are abundant. The latter grow wild in great profusion, in old, uncultivated fields. Forest trees are large, abundant, accessible to saw mills, and well adapted for lumber.

Of the various trees, I may enumerate the Pine, Tulip, Chestnut, seven varieties of Oak, Hickory, &c., which are common everywhere. The Walnut, Locust, Wild-Cherry, Maple, Sycamore, and other useful lumber trees, are found in various parts and bring remunerating prices in market. Lumber is worth from \$1 to \$1.50 per hundred; shingles, of heart-pine, from \$2.25 to \$2.50 per thousand, in the county—at the stump, \$3, if delivered.

2d. *The Climate.*—This is mild. But little snow falls in the winter, and does not remain longer than a day or two at a time. The winters, indeed, are so mild, that we sometimes are unable to procure ice, unless the ice ponds are in northern exposures, and very shaded situations. The face of the country is undulating, the water generally excellent, and the climate so salubrious that the services of many physicians are not required. I frequently ride twelve and fifteen miles to see a patient, and in the course of three years' practice I have had only two cases of *Fever and Ague* (they contracted elsewhere) and one of *Bilious Remittant*. This is not asserting that all parts of this section of Virginia are universally healthy. In some parts, especially larger water courses, Intermittent and Remittant Fevers do occur, but not to any great extent. I think I may safely say, that we have no diseases endemical to this country, though we have our share of the epidemics which prevail throughout the United States, with the exception of Cholera.

Finally. *Education and Morals.*—Primary schools and high schools of superior merit, are accessible. The minds of the people are becoming fully aroused to the importance of attention to the subject of Education. Churches are scattered, at intervals of eight or ten miles, throughout the country. Preaching at the country churches is held twice a month, and the days are so arranged that persons, if they choose, can conveniently attend services nearly every Sabbath. The Baptists (missionary) are most numerous. We have, however, some Presbyterians, Methodists, and Episcopalians. The three last have each a church at Chatham, our county seat.

This is as much as I have time to write, and more, I fear, than the *Farmer* may be willing to publish. People who wish to know more, will have to do like the Queen of Sheba, come to Jerusalem to see for themselves, "for the half has not been told them." S. AUGUSTINE WALKER.—*Pittsylvania Co., Va.*

Horticultural Department.

CONDUCTED BY P. BARRY.

SPRING-FLOWERING TREES AND SHRUBS.

THERE is a great want of information on the subject of ornamental trees and shrubs. With the exception of the *Horse Chestnut*, the *Mountain Ash*, the *Lilac*, and *Snowball*, the great variety of ornamental trees and plants enumerated in nursery catalogues are comparatively unknown. Ornamental planting every year attracts more and more attention—information on the subject has become a matter of every-day inquiry, and we have really no cheap treatise on the subject, such as our works on fruit culture, that we can refer to. To aid a little in supplying this deficiency, we propose henceforward, as opportunity may offer, to notice briefly the most desirable hardy trees and shrubs for limited collections. We shall begin with the

FLOWERING ASH; (ORNUS EUROPEUS.) *Syn.*—FRAXINUS ORNUS.

This is neither a rare nor a common tree, a native of the south of Europe, but introduced into this country a long time ago, and widely disseminated, but confined to larger collections of trees. There is an American species, so similar in appearance as to be



FLOWERING ASH.

pretty generally believed to be only a variety. It resembles the common ash in its general features. Habit stiff and erect; with grayish bark; stout, blunt shoots; and large, dark buds. Leaves consisting of three or four pair of elliptic or lanceolate leaflets. Flowers, which appear in the latter end of May or beginning of June, are of a greenish white, produced in large clusters or panicles on the ends of the branches. These clusters are shorter than the leaves that surround them; and when the tree is in full bloom, it looks as though a pretty white bouquet of delicate flowers, tastefully encircled by foliage, were placed on the end of every branch. The annexed figure will give a slight idea of the relative situation of the leaves and flowers, and their appearance.

It is propagated by budding or grafting—the latter is preferable—on the common ash. It grows slowly, and attains a height, in time, of twenty to thirty feet. Specimens in our grounds, ten years planted, are twelve feet high. In Italy, where this tree abounds indigenously, the sap is taken from it in the summer, as we take the sap from the sugar maple in the spring; and as it cools, it hardens and granulates, and is then called “manna,” and is that now generally known in commerce.

THE SILVER BELL, OR SNOWDROP, TREE; (*HALESIA TERAFTERA*.)

This is, as very justly remarked by Loudon, "one of the most ornamental of American deciduous trees, and richly deserves a place in every collection." It grows indigenously in the southern and southwestern States. It has long been cultivated in the nurseries, and may be found in most large collections; but it is by no means common. It attains the height of fifteen or twenty feet, but may be kept within the dimensions of a medium sized shrub, where desirable. A plant in our grounds, seven or eight years old, is not over six feet high, and has blossomed profusely for several years.

The leaves are long, pointed, and downy; blossoms pure white, bell-shaped, pendulous, and produced in great abundance on the wood of the previous year; seeds four-winged. Its period of blooming here is in the latter end of May or, in late seasons, beginning of June. It is propagated from seeds; but they seldom vegetate before the second year after planting. It is also propagated from *layers* of the young wood; but they require to be two years in the ground before sufficiently rooted to be removed from the mother plant. This tardiness of the seeds to grow and the layers to root, has no doubt very much hindered its dissemination.



THE SNOW-DROP.

HINTS FOR JULY.

SUMMER PRUNING must be continued, to regulate growth, by pinching off the ends of too vigorous or irregular growing shoots, and all such as are superfluous. Fruit-bearing may be induced by stopping all such shoots as may not be wanted in the frame-work of the tree. In the case of garden trees especially this treatment is necessary.

Thinning Fruit.—Dwarf pear and apple trees in many cases bear too heavily, and few people are disposed to relieve them of their ill-proportioned load. They are considered as curiosities, and are allowed to exhaust themselves. Those who desire fine specimens, and regard the future health and prosperity of their trees, will reduce the crop to a reasonable quantity. Thinning should not be confined to dwarf trees, but will be highly beneficial in all cases where trees are very heavily loaded. Valuable trees are frequently lost by being broken down or debilitated by an overload.

Budding will commence in the latter part of the month. Plums generally require to be done about this time, unless on such stocks as grow late in the season.

Look to spring grafts, and see that they are not robbed by shoots from the stock below them; tie up any in danger; and check irregular growth.

Strawberry beds, now that the fruit is gathered, will receive attention. Weeds must be all removed and runners cut away. If it be intended to renew the beds by spading down the old plants, the young runners must be preserved and kept clean until well rooted before the old ones are turned in. New beds may be made about the latter end of the month or beginning of August. Do it, if possible, in a showery time, and shade the plants well.

Insects must be watched and destroyed continually. The green and black *aphis*, that infest in great numbers the leaves of the cherry, apple, &c., are easily killed with a solution of tobacco. This may be made by steeping stems in water until it has become as dark as strong beer. It may be put on with a syringe, or the branches may be dipped in it if the trees be young. Several applications may be necessary. The *slugs* that affect the leaf of the pear and cherry, are easily destroyed by sprinkling over them lime, ashes, or dust of any kind; but this also needs to be repeated frequently. *Caterpillars* of various kinds attack the foliage of trees at various seasons. The best mode of destroying them is well known.

Culture.—Keep the ground clean of weeds, and the surface in a finely pulverized state, around all young trees and plants where good growth is desired. When it becomes hard and cracked on the surface, or covered with weeds, growth is greatly retarded.

Layering, one of the best methods of summer propagation, may now be attended to. The greater number of ornamental shrubs, and roses of all kinds, may be thus increased. Spade and prepare the ground well around the plants; bend down the shoots and fasten them in the ground by means of a hooked peg; (the new wood in most cases is the part to lay;) and if a slit be made half through, just below a bud and extending an inch or so above the bud, roots will be emitted sooner and more surely. The top of the layered shoot above the ground should be put in an erect position, and the slit made below kept open: thus the sap is arrested at the cut part, and there forms roots. A layer is but a cutting not quite separated from the mother plant, but allowed to derive some support from it until it has formed roots of its own; hence more certain.

Budding of roses, and many other things that have ripened buds, may be proceeded with through all July.

Dahlias must be kept carefully tied up and pruned where there is too great luxuriance. Staking is necessary for all tall growing plants in the flower garden or border; if not tied up, they are almost sure to be broken when their heads are heavy with bloom.

Hyacinth and Tulip beds, where the bulbs have been taken up, may now be occupied with petunias, verbenas, heliotropes, salvias, and any other rapid growing bedding plant that will make a good display in the autumn.

PEARS ON QUINCE STOCKS.

In a late discussion on fruits, which took place at the agricultural meeting at the State House in Boston, Col. WILDER made some interesting remarks on this subject, which we reprint:

"Much attention has been given of late years to the cultivation of the pear on the quince stock, and in relation to which I have been requested to give the results of my experience. As a general rule, no tree will succeed for any great length of time where it is grafted on any other than its own species. There are, however, exceptions to this rule, and among them, some varieties of the pear, which grow vigorously, bear abundantly, and which seem to be even better adapted to the quince, than to their own stock.

"An impression has extensively prevailed unfavorable to the cultivation of the pear on the quince. This has arisen principally from an improper selection of kinds, or from injudicious cultivation. There are, however, three considerations which are absolutely necessary to success, viz., a deep, rich soil,—

the planting of the quince stock entirely below the surface of the ground,—and a systematic and scientific course of pruning, as the tree progresses in growth.

"Objections to this species of cultivation have been made from the belief that the quince was a short-lived tree, and that the crop must necessarily be small from what are termed dwarf trees. Such, however, has not been my experience. On the contrary, I have pear trees on the quince root which are twenty-five years old, and which produce annually a barrel or more of fruit each, and for aught that I can see, they are destined to survive as long as any that I possess on the pear root. These may, and probably have in some instances, thrown out roots from the pear stock, but whether this be so, or not, instances are not rare where such trees have attained in France the age of more than a hundred years, and we know of a quince tree in Massachusetts which is forty years old, and which has produced ten bushels of fruit in a season.

"The pear, when grown on the quince, should always be trained in the pyramidal form. These may be planted in much closer order than when grown as standards. We have known them to succeed well where grown at the distance of six feet apart in the rows. In this way Mr. RIVERS, the great English cultivator, planted 2500 *Louise Bonne de Jersey* and 1500 *Glout Moreau*s for the London market. We consider 12 feet apart, each way, a liberal distance. This would give 302 trees to the acre, and we are clearly of the opinion, that soil and selection of the varieties being right, no crop whatever would be more profitable. Such a plantation, with proper care, would yield, in the fifth year, from 75 to 100 bushels of fine fruit. As to profit, this will not appear as an exaggeration, when it is known that *Glout Moreau* pears, a variety which succeeds admirably on the quince, have sold during the winter readily at one to two dollars per dozen, in our market.

"We name as varieties which succeed well on the quince, the following, and to which might be added many more: *Louise Bonne de Jersey*, *Vicar of Winkfield*, *Duchess d'Angoulême*, *Glout Moreau*, *Passé Colmar*, *Urbaniste*, *Belle et Bonne*, *Beurre d'Anjou*, *Beurre Diel*, *Éclair*, *Beurre*, *Beurre d'Amanlis*."

We commend the above article to the attention of those who are seeking reliable information on this subject. Col. WILDER's statements are entitled to the fullest confidence. We must add, however, that from what we have seen and learned last season, both at home and abroad, we have concluded to abandon the *Urbaniste* on quince; we feel satisfied it will not be durable. We would add to the above list, *Belle Lucrative*, *Dojenne Boussock*, and *White Dojenne*. These succeed well, and are indispensable, in our opinion, even in small collections.

•••••

HAND BOOK OF WINES.—THE APPLETONS have published a book under this title, which we have seen noticed in several newspapers. A writer in the *Western Horticultural Review* takes the author (THOMAS McMULLEN) severely to task for his very remarkable and culpable neglect of the wines and wine interests of America, and concludes thus:

"It would probably be out of place to anticipate in this article the statistics and facts in relation to the grape culture and wine making in this vicinity, now being prepared by a competent hand, and which will shortly be made public; otherwise we should take great pleasure in offering, for the edification of the public generally, and Mr. McMULLEN in particular, a statement from materials in our possession, which would go to prove the great extent and importance of this branch of industry. We may say *en passant*, however, that this culture embraces more than a thousand acres of vineyards, many hundreds of laborers, and that there is a value embarked in this business alone, in land, material, fixtures, stocks on hand, etc., that will reach half a million of dollars. We know of three individual concerns, whose vineyards, wine-houses, stocks, and materials, will reach two-fifths of this sum.

"In conclusion, we venture the prophecy, that the culture of the grape, and the manufacture of wine in the valley of the Ohio, in the vicinity of this city, is destined to reach a point of importance not yet dreamed of; and which will ere long exert a moral and healthful influence upon society, that the friends of temperance have thus far vainly sought to attain."

No wonder, really, that the wine-growers of Cincinnati should feel slighted in an American book on wines.

•••••

HORTICULTURE IN PHILADELPHIA.—A new monthly gardening journal has been commenced in Philadelphia, called the "Philadelphia Florist." We have not seen it, but learn that it is conducted by "a committee of practical gardeners." That city, in many respects, has more of horticultural interest about it than any other in America. In floriculture, especially, this is true, and a journal well conducted there would be well received. We have some doubts, however, about the success of editorial "committees." We have no recollection of any of these holding long together.

LETTER FROM CRAWFORD COUNTY, PENN.

A GENTLEMAN from Crawford county, Penn., who favors us occasionally with a pleasant and instructive letter, writes us as follows under date of April 29. We take the liberty of publishing it (omitting his name, as it was intended to be private,) on account of the items of local information it furnishes in regard to fruit and other kindred matters.

"Our season here is still very backward, and there seems to be a universal wail in the western country over the severity of the winter. No doubt a good deal of half-frozen wood will give rise to much theorizing speculation on the blight, next July and August—for the pear frequently looks well, and grows well, for a while, when amputation in the spring will disclose the wood to be discolored, and the sap vitiated, by the frost and therefore fatally diseased. I am inclined to think favorably, in the pear culture, of stripping the outer bark from the tree when the tree is about to change from the smooth into the rough state. Have you ever tried it? In this region, the wood of fruit trees matured very well last fall, and in taking a survey of my own premises, with the exception of a couple of frozen grafts, I find but little to regret. The peach trees look very well; and though the blossoms have been severely thinned out, a sufficient number are swelling into bloom for a crop, if they bear fruit. The pear trees bid fair to bloom abundantly, and I find that some raspberries (*Franconia* and *Fastloff*) which I left unprotected, except by the shade of a fence, are entirely uninjured. Strawberries I protected with some straw, and they look unusually well. I intend to try the hydro-pathic treatment of them this spring, as it seems to be highly commended by some cultivators who have tried it.

"I had a fine succession of peaches last fall, lasting for six weeks and ending with the *Heath Cling*, which here will only ripen imperfectly. Among those that fruited, I had the *Red Raricripe*, *Prince's Raricripe*, *Early York*, *Astor Noblesse*, *Grosse Mignonne*, *Morrison's Pound*, *Morris' White Raricripe*, *Sweetwater*, *Barrington*, *Oldmixon Free*, *White Cling*, and *Lenon Cling*. Though some of them bore larger and more showy fruit, yet the richest and highest flavored peaches I had were on a tree I got from you some years ago, labelled *Grosse Mignonne*. The tree has small blossoms, when, according to DOWNING, it should have large; but the fruit could recommend itself under any name.

"A peach introduced here from Cincinnati as the *Washington*, proves to be identical with *Morris' White*. I think very highly of this variety. I see you quote it as *medium* size; my tree bore a moderate crop, but the fruit was all large.

"The *Northern Spy* apple has been introduced into our market this last winter, from Chautauque, and created quite a sensation. It is certainly quite a magnificent looking fruit, and about as good as it looks. It seems to keep as well as the *Fallwater*, and, though the average size is somewhat less, it quite surpasses it as a dessert fruit; while its rich coloring, and fine appearance, must always make it a most popular fruit.

"After being behind the age for a long time, we have at last succeeded in forming an agricultural society in our county, which I think will be productive of much good to the farming interests. We shall probably not contend with the "black knot," and pear and potato blight, with any better success than has been done elsewhere; but it will promote a taste for agricultural and horticultural reading. From the wide field of experiment, our farmers can note what instances have been attended with fortunate results, the adoption of which will introduce something new each year into their mode of farming, and break up the drudgery of too uniform a system. A new test is in this way imparted to agricultural pursuits; while the emulation created by societies and fairs leads gradually to the adoption of a higher standard of culture.

"We have now the last of April, and the fruit trees look as though they would not be in bloom for ten days to come. Gardening is much later than usual, but I do not regret it, as I think in nine cases out of ten, things planted late, when the ground is warm, do better than those started earlier."

* No; nor do we intend to very soon. At present we are not aware of any necessity for it here.—Ed.

AMERICAN POMOLOGICAL CONGRESS.—In compliance with a Resolution passed by the American Pomological Congress, during its session at Cincinnati in October 1850, it becomes my duty publicly to announce that the next session will be held in the city of Philadelphia, on Monday, the 15th of September, 1852. The Congress will assemble at 10 o'clock, A. M., in the Chinese Museum Building, South Ninth street, below Chestnut.

The Pomological, Horticultural, and Agricultural Societies, throughout the United States and Canada, are invited to send such number of Delegates as they may deem expedient. And the Delegates are requested to bring with them specimens of the fruits of their respective districts.

Packages and boxes of fruit for the Congress may be directed to the care of THOMAS P. JAMES, Esq., No. 212 Market street, Philadelphia, should the owners be unable to give their personal attendance. The various State Fruit Committees will, on or before the day of meeting, transmit their several reports to A. J. DOWNING, Esq., general Chairman of the whole. The Chairman of each State Committee is authorized, where vacancies occur, to fill up the number of his Committee to five members.

Philadelphia, May 1, 1852.

W. D. BRINCKLE, M. D., President.

HORTICULTURAL SOCIETY OF THE GENESEE VALLEY.—This Society held its second exhibition of the season on the 22d of May. The display was not large, but the articles presented were very fine.

Mr. JOHN DONNELLAN made a fine show of lettuce, radishes, and asparagus.

Mr. CROSMAN—fine rhubarb and cucumbers.

MESSRS. A. FROST & Co. exhibited a small collection of fine pot roses, including *La Sylphide*, (Tea,) and *Comte Bobrinski*, (Hybrid Perpetual;) several specimens of verbenas, azaleas, rhododendrons in bloom; a plant, in bloom, of the *Double White Chinese Primrose*; good specimens of Auracaria, Cryptomeria, and Deodar cedar, in pots.

WM. WEBSTER, with MESSRS. BISSELL & HOOKER, six fine varieties of seedling calceolarias—a very pretty contribution.

ELLWANGER & BARRY made show of cut flowers of early blooming trees and shrubs, such as *Spiræ prunifolia*, *Mahonia aquifolia*, *Cerasus padus*, or Bird Cherry, *Coloneaster affinis*, *Pyrus Japonica*, *Judas Tree*, magnolias *Conspicua* and *Purpurea*, &c., &c. Roses in pots—*Geant des Batailles*, and several others. Cinerarias—a fine show of seedlings, besides *Beauty of Flushing*, *Carlotti Grisi*, &c. Calceolarias—many fine seedlings. Hyacinths, early tulips, narcissus, &c.

Mr. DONNELLAN made a good show of pot-plants, including a fine *Cactus Jenkinsoni*, a specimen of rose *Queen of the Bourbons*, petunias *Enchantress* and *Prince of Wales*, several verbenas and pelargoniums.

MESSRS. SHEPPARD & CHERRY presented some finely preserved specimens of apples—*Baldwin*, *North-ern Spy*, *Rhode Island Greening*, and *Esopus Spitzenburg*.

May 31st.—The third exhibition was held to-day. The tulip was the leading feature, although the contributions of this flower were few and small compared to what they ought to be. But two amateur cultivators exhibited—Mrs. JNO. WILLIAMS and Mrs. JEWELL;—both very pretty collections. Among nurserymen Messrs. JNO. DONNELLAN, WM. KING, and ELLWANGER & BARRY, were the only exhibitors of tulips.

MESSRS. FROST & Co. made a good display of roses, among which we noted *Blanche Vibert*, o. c. of the few pure white Hybrid Perpetuals. Several varieties of verbenas, geraniums, &c.

WM. KING—a good collection of pansies, calceolarias, fuchsias, &c. Among the latter we noted very fine *Snow Drop* and *Pearl of England*.

Mr. WEBSTER—a table filled with pot-plants, fine seedling calceolarias, and other plants.

ELLWANGER & BARRY exhibited cut flowers of a large collection of trees and shrubs. Five varieties of spiræas, eleven of lilacs, six of berries; Red, White, and Yellow horse-chestnuts; Flowering ash, (*Ornus*;) Yellow azaleas; magnolias; four varieties of upright honeysuckles; the Judas Tree, (*Cercis*;) the Cotoneaster, Viburnums, &c. *Pot-Plants*—Roses, cinerarias, mimaduses, fuchsias, calceolarias, &c., &c. *Bulbous Plants*—Tulips of the various classes; five or six late varieties narcissus; several early herbaceous pæonies; tree peony *Bankse*, and a new distinct one *Koeklini*, purplish rose color, very double and compact, and the petals fringed.

Wild flowers were shown by L. WETHERELL, Esq.—some forty species, all named. We hope to see more competitors hereafter in this department. From among so many students of botany in our schools and seminaries, so many teachers, &c., can we muster only one exhibitor. Shame!

Vegetables were exhibited in great perfection as usual by JNO. DONNELLAN and C. F. CROSMAN.

PEACH TREES.—The injury to peach trees from the severe winter has been much greater than we supposed. They blossomed nearly as well as usual, but a large portion of the blossoms fell without setting fruit; the leaves expand slowly and feebly; young shoots are weak; and in every part a debility is indicated—the consequence, no doubt, of the severe frosts. In some cases, old trees are completely killed. Our peach crop will be very light. H. P. BYRAM, Esq., of Louisville, writes in the June number of the *Horticultural Review*: “The larger portion of my pear and cherry blossoms are killed. Most of the varieties of apples are safe. Quince trees are nearly all killed to the ground, and the peach trees are badly injured.”

STRAWBERRIES made their first appearance in Cincinnati on the 14th of May. We shall have none in Rochester till about the last week in June. More than a month of difference in the season of this fruit between Rochester and Cincinnati—a twenty-four hours' journey. An exchange might be advantageously made between the two places. The people of Buffalo have been supplied with green peas from Cincinnati a month before they can have them from their own gardens. See what railroads do.

Ladies' Department.

ANNUAL FLOWERS.

At the commencement of the present volume, we determined to give during the year



SALPIGLOSSIS.

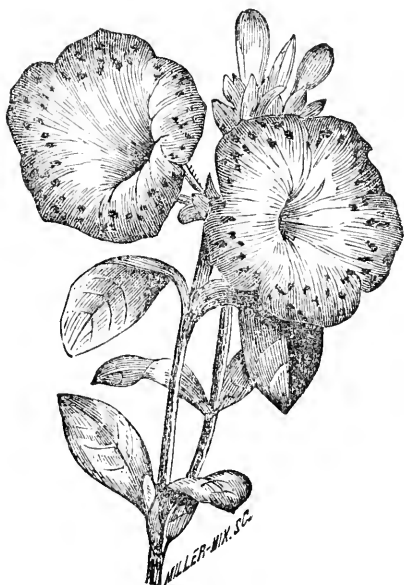

PETUNIA PUNCTATA.

figures and descriptions of the best annuals. This design we have carried out thus far, having given both engravings and descriptions in every number but one, when the matter prepared was unavoidably crowded out by the excellent article on the *Fuchsia*, by our horticultural associate. As the season progresses, and our choice annuals come into bloom, we shall have them drawn and engraved, and given a place in the *Farmer*. Those ladies who have become subscribers merely for our *Floral Department*, we are determined shall receive full value. We are occasionally asked for descriptions of flowers which we have before given in previous volumes. To these requests we may occasionally comply.

SALPIGLOSSIS.—The *Salpiglossis* is a native of Chili, and was introduced into Europe in 1824. It bears a strong resemblance to the petunia. The genus contains many varieties, and are all funnel-shaped, like the petunia, but not so broad.

PETUNIA.—The *Petunia* is a native of South America. It is easily propagated either by cuttings or seeds, and is a general favorite. The seeds only require scattering in any common garden soil to grow and flower freely. When grown thickly in a bed, they intermingle and form masses of great beauty, and no dry weather injures them—keeping in blossom until destroyed by frost.

The season has been so cold and backward, that we fear many of the early planted flower seeds have suffered. June 10th we had a fine lot of plants, raised in a bed for transplanting, destroyed by frost during the night. At the present time (June 18) the weather is moist and warm, and vegetation progressing rapidly.

Editor's Table.

PREMIUMS.—Below we give the award of premiums for the present year. In addition to the names here given, a great number of persons have procured large lists of subscribers, to whom we are, as formerly, much indebted. We feel great pleasure in being able to scatter useful books on agriculture over the land. As we observed, on offering these premiums, they must increase the knowledge, and consequently the power and the wealth of those for whose especial benefit we labor. We do this for the good they accomplish, as well as a slight compensation to our friends—the friends of rural improvement—throughout the country, who act as voluntary Agents, with the expectation of pecuniary reward.

PREMIUMS TO INDIVIDUALS.

1st. WM. L. BADGLEY, Springville, Erie Co., N. Y., for the greatest number of subscribers sent by one individual, (153,) *Thirty Dollars* in agricultural books.

2d. CHARLES P. DIBBLE, Marshall, Mich., *Twenty Dollars*, for the next greatest number, (121.)

3d. JOHN SMITH, Prattsburgh, N. Y., *Ten Dollars*, for the third greatest number, (113.)

COUNTY PREMIUMS.

1st. CHAUTAQUE COUNTY, N. Y., *Forty Dollars* in agricultural books, for the greatest number of copies of the *Genesee Farmer* taken in any county, being 490. This Library, according to the offer, is "to be kept as a County Agricultural Library, under the care of the Agricultural Society."

2d. STEUBEN COUNTY, N. Y., *Twenty-Five Dollars* in agricultural books, for the next greatest number, (473,) on the same conditions as above.

COUNTY PREMIUMS OUT OF NEW YORK.

1st. ERIE COUNTY, Pa., an Agricultural Library worth *Forty Dollars*, for the greatest number of copies of the *Farmer* taken in any county out of the State of New York, (333.)

2d. CALHOUN COUNTY, Mich., *Twenty-five Dollars* as above, for the next greatest number taken in any county out of the State of New York, (216.)

Selections of books can be made by those entitled to them, or the choice left to us. Those entitled to premiums will please order.

MONROE COUNTY PLOWING MATCH.—The Monroe County Plowing Match took place at Brockport on the 17th ult. There were sixteen competitors, all of whom did their work in a very creditable manner. The plowing was, on the whole, the best we ever saw on any similar occasion,—and we have attended many plowing matches both in

Europe and America,—and made us feel proud of Monroe county. There was a large concourse of farmers and others interested in agricultural matters present, say 1,500, who listened to an interesting address from HORACE J. THOMAS, of Brockport.

The method of plowing adopted was a much better test of the plowman's skill than the one generally practiced. Instead of throwing up a double furrow in the center of the land to be plowed, and then *turning from you* all the time till the land is finished, each plowman threw up a double furrow in the old dead furrow, as in the other case, and then turned toward him, or "hewed round," and came up the furrow of his next neighbor. This showed the skill of the plowman in raising a double furrow, and likewise, what is a much more searching test of a plowman's capabilities, *his skill in turning the last two furrows and leaving a well finished dead furrow.*

The judges were a long time in deciding on the respective merits of the plowmen, so that when they made their report, nearly all had left; and indeed such was the excellence of the plowing, that it was by no means easy to decide which was the best, and we anything but envied them the task; yet we must say that the decision accorded with our own opinion, and so far as we know, with most others who examined the lands carefully.

The following is a list of the successful competitors:

First Premium, \$8, to COLES GREEN, of Clarkson. HENRY CLARK, Plowman.

Second Premium, \$6, to F. P. ROOT, of Sweden. A. OOTOURT, Plowman.

Third Premium, \$4, to GEO. W. GOODRUE, of Wheatland. GEORGE ASHAM, Plowman.

Fourth Premium, \$2, to L. GILLSPIE, of Sweden.

Fifth Premium, Vol. Trans., to GEO. H. GOODRUE, of Wheatland, (under 18 years old.)

Sixth Premium, Vol. Trans. of Am. Institute, to ALLEN SLOCUM, of Clarkson.

Among the implements exhibited on the ground, and which struck us as being improvements on the old ones generally in use, were—

A Patent Wheel Cultivating Gang-Plow, invented and manufactured by HERVEY KELLAM & GEORGE VALLEAU, of Scottsville, N. Y. It is so arranged that the tongue can be placed to work equally well with three or two horses, and it is connected by iron rods with the axles of the

wheels, so that when the tongue is moved round, it alters the course of the wheels without turning the body of the implement. By this ingenious contrivance the plows can be turned round without any strain on the wheels, in a very little space. The depth is regulated by the wheels, which are raised or lowered in the same manner as in Ide's Cultivator. The price is \$30.

Root's Patent Cultivator, manufactured by J. GANSON & Co., Brockport, N. Y., was highly spoken of by some farmers present who had used it. It differs from Ide's Cultivator in having the side wheels placed forward and a small wheel running behind in the center of the cultivator. The principal advantage we observed in it was that the tongue could be moved up and down without affecting the cultivator, and that consequently there is no strain on the neck-yoke, as is sometimes the case with the ordinary cultivators.

We were much pleased with a remark of Mr. GOODRUE, of Scottsville, two of whose sons were among the competitors, (one of whom, under 18 years of age, carried off the fifth premium, and the other one, under 14 years of age, likewise well deserved one,—and we understood at the time it was the intention of the committee to award him a special premium.)—"If farmers would only bring their sons to these plowing matches, and encourage them to compete, instead of letting them go to circuses and other places that deprave their taste, we should soon see a difference in the plowing of the county." We hope the hint will be acted on, and that our State and County Societies will do all they can to encourage competition among the boys, in the best method of turning over the sod.

LETTER FROM LIEBIG.—BARON LIEBIG has addressed a letter to the editors of the *Journal of Agriculture*, Boston, from which we extract all of general interest. The Baron is certainly modest, in thinking it "not best to oppose too obstinately the efforts of farmers to test the strength of scientific principles after their own fashion." The remarks on the state of his own country, and the "appalling" increase of emigration, is interesting to every American citizen, and none the less so to the rulers of Europe.

"I have heard a great deal of your efforts to improve agriculture in your country; and, what is of the greatest importance, to enlighten the farmers on the means, which are indispensable to attain that purpose. You will find, as I did, that agriculturists, in general, are not very grateful for it. They are men, after all; but, in regard to the teachings of science, they act like children, who cannot see the purpose and use of going to school; although whatever of good or useful they achieve in after-life is only in proportion to the sum of knowledge thus acquired.

"Farmers can fully appreciate the value of a sum of money, that may be given to them, on purpose to improve their fields; but the advantages of science, by the aid of which they could make as much, they do not estimate highly

enough, because so to do requires meditation and mental labor. The services of science would be better received, if she could give every one a receipt—a ready-made, right down prescription—to fertilize land, without requiring any further thought or inquiry.

"But to do that is impossible; and hereby you may know the man of solid knowledge from the mere empiric—that the experiments of the former succeed, while those of the latter are forever doubtful. Science includes the art to infer useful hints from every trial.

"The lack of a judicious understanding of the true principles of agriculture, is the reason for the many attacks which her doctrines have met with in England; but in the course of time these obstacles will be of no consequence. In a few years farmers will find that what has been substituted for science is not at all of general application; and that only a few of those who imitate Mr. LAWES or Mr. PUSEY, will obtain the same favorable results; because different ground requires different conditions in order to yield a maximum of product. The real advantage of science to a farmer, consists of a knowledge of those several conditions; and he is a spendthrift, if he applies the same thing to every kind of land.

"In the whole of Wurtemberg (the soil of which consists principally of Aena limestone) carbonated bones have not the least effect; and even guano is held in no estimation there, for the reason it renders the grain weed-like; and, by giving no strength at all to the stalks, makes it bend to the ground long before ripe. To conclude, therefore, that carbonated bones and guano are bad manure, would certainly be quite absurd.

"I think it advantageous not to oppose too obstinately the efforts of farmers to test the strength of scientific principles, after their own fashion. It always affords me pleasure to find my views violently attacked, and if he who does so, brings forth a complete mass of ignorance and nonsense. The consequence is, necessarily, that their own children, more enlightened than their sires, will requite the attack.

"I would like once to see your happy country, where the well-earned fruits of activity and industry are enjoyed without let or hindrance. With us, too, much is consumed by the institutions of the States. The people must work too much to sustain standing armies of men, fully able to work yet producing nothing. This is the curse of Europe. Emigration increases to an appalling degree, and now the intelligent and wealthy begin to leave the land of their fathers, because they know their children will enjoy a happier future in America.

Farewell, dear Sir,

* * * * *

Most respectfully, JUSTUS LIEBIG."

GIVING CREDIT.—Although none have suffered more by the pilfering propensities of their contemporaries, none have complained less. Should we open a mail without finding some of our articles taken bodily, without a word of acknowledgement, or, what is worse, credited to some paper that had before pilfered it from our pages, we should note it down for future reference, that "now, about this time," there was a great improvement in the morals of the press. On this subject, the Boston *Journal of Agriculture* says:

"Our course was laid down at the commencement of our career. We cut off the exchange with any paper that, three times in one volume, appropriates our articles without credit. The consciences of such can always answer, if interrogated, why they no longer see the *Journal of Agriculture*?"

We fear if we were to adopt this rule, we should have to part with about one-half of our exchanges. We shall certainly apply it to some of the most incorrigible. All the articles in the *Farmer* are original, unless full credit is given.

We invite attention to the advertisement of a "Fruit Farm in Ohio for sale." Mr. BAYNEHAM informs us that the price is \$40 per acre, in three annual payments, with a reduction for cash.

PRESERVE YOUR NUMBERS.—Kind reader, we are furnishing you a paper each month that is well worth preserving. Set a few stitches through the back, cut the leaves, and then you are ready to read a number comfortably. As soon as all have read it, lay it aside carefully for binding at the end of the year. If you don't live within a hundred miles of a book-binding, stitch them together. Do this, and we modestly think that you will have a book at the end of the year, that no sane man would sell for a dollar.

THE TRIAL OF IMPLEMENTS by the N. Y. State Agricultural Society, will take place near Geneva during harvest. The day is not yet determined, but will be published in season, in the local papers. Grain Reapers, Mowing Machines, Seed Drills, &c., are then to be tested. A mechanical exhibition is to take place at the same time, in Geneva, under the direction of its citizens. It will be an interesting exhibition.

POULTRY EXHIBITION IN ROCHESTER.—The Monroe County Agricultural Society have determined to hold a Poultry Exhibition in connection with the next County Fair, (Sept. 29th and 30th,) to be open to the State. The premium list is liberal, and we anticipate a fine display.

THE MUSICAL WORLD AND JOURNAL OF THE FINE ARTS.—We have received this Journal for the last two or three months, and recommend it to all who would keep pace with the times in respect to musical intelligence. Terms, \$1.50 per annum, in advance. Published on the 1st and 15th of each month, by OLIVER DYER, No. 257 Broadway, New York.

SAXTON'S RURAL HAND-BOOKS.—C. M. SAXTON, of New York, is publishing a series of small books, at 25 cents each, after the style of a series published in Dublin. We shall notice these and other books in our next.

PLANTATION AND FARM INSTRUCTION, REGULATION RECORD, INVENTORY, AND ACCOUNT BOOK: By a Southern Planter. Published by J. W. RANDOLPH, Richmond, Va. The above book was handed us by our friend ERASTUS DARROW, Bookseller, Rochester, N. Y.

ADVERTISEMENTS, to secure insertion in the Farmer, must be received as early as the 10th of the previous month, and be of such a character as to be of interest to farmers. We publish no other. Terms—\$2.00 for every hundred words, each insertion, *paid in advance.*

EXCHANGE PAPERS have laid us under many obligations for their friendly notices.

AGRICULTURAL FAIRS.—Below we publish all the agricultural Fairs to be held this fall that have come to our knowledge. The officers of any that have been omitted will please notify us, giving time and place. Those sending notices in papers, will please mark them, or they may escape our notice.

STATE FAIRS.

New York, at Utica.....	Sept. 7, 8, 9, 10
Ohio, at Cleveland.....	" 15, 16, 17
Michigan, at Detroit.....	" 22, 23, 24
Canada West, at Toronto.....	* 21, 22, 23, 24
Vermont, at Rutland.....	" 1, 2, 3
Pennsylvania.....	Oct. 20, 21, 22
Wisconsin, at Milwaukee.....	" 6, 7, 8
Georgia.....	" 15 16 23
Maryland, at Baltimore.....	" 26, 27, 28, 29
American Pomological Congress, at Philadelphia.....	" 13
American Institute, at New York.....	" 5
Exhib. of Stock.....	" 19, 20, 21
Rhode Island Society of Improvement, at Providence.....	Sept. 15, 16, 17
New England Society for Improvement of Poultry, at Boston.....	" 7, 8, 9, 10

COUNTY FAIRS.

Saratoga, at Mechanicville.....	Sept. 15, 16, 17
Rensselaer, at Troy.....	" 22, 23, 24
Clinton, at Keeseville.....	" 22, 23, 24
Essex.....	" 20, 21, 22
Suffolk, at Huntington.....	" 21, 22
Onesago, at Morris.....	" 22, 23
Jefferson, at Watertown.....	" 16, 17
Cortland.....	" 15, 16
Herkimer, at Herkimer.....	" 28, 29
Ontario, at Canandaigua.....	" 29, 30
Monroe, at Rochester.....	" 29, 30
Wyoming, at Warsaw.....	" 22, 23
Seneca, at Waterloo.....	Oct. 14, 15
Genesee.....	" 6, 7
Cayuga, at Auburn.....	" 6, 7
Fulton, at Carmel.....	" 5, 6

TOWN FAIRS.

East Bloctfield.....	Sept. 22
Galen, at Clyde.....	July 3, 4

Inquiries and Answers.

SCAB, AND GRUB IN THE HEAD OF SHEEP.—Is the Scab of Sheep contagious? Is it confined to the skin? and what is the best remedy? Also, for the Grub in the head? An answer would oblige myself, and many other of your subscribers in this section. A. C.—*Wancondo, W.*

The scab in sheep is caused by a parasitical insect, the *acari*, and is exceedingly contagious, so much so, indeed, that it seldom makes its appearance in a flock without affecting the whole. The cause of contamination, however, is not so much from a sound sheep coming in direct contact with a diseased one, as by rubbing themselves on the same posts, &c. As soon as it is discovered, all the affected sheep should be immediately removed from the flock, and the sound ones turned into fresh pastures or folds, where they should be well watched, and any that may show symptoms of the disease be instantly taken away.

The best and surest remedy, if applied with care, is the common unguentum diluted with five times its weight of lard. Rub a little on the sheep, and then open a furrow along the back and with the finger apply a little and rub it well in;

then open another furrow on each side of the sheep and apply as before, rubbing it well in. Half an ounce is an ordinary dressing, but if the case is an aggravated one, $1\frac{1}{2}$ oz. may be used. It is usually the worst about the shoulders. A strong decoction of tobacco, with the addition of a little spirits of turpentine, is recommended by some, but we have never used it, though it will probably be found efficacious. The unguentum is a certain cure, and if used with ordinary care is perfectly innocuous.

The worm in the head is caused by a fly of a light drab color, which deposits its eggs in the nostrils of the sheep, from July till late in the fall. When the worms are hatched they begin to ascend the nostrils in search of food and soon enter the head, where they feed on the vitals, when death soon ensues, often very suddenly, though sheep sometimes live several months after they have exhibited symptoms of being attacked, but they grow very poor and have a sickly appearance, often snorting as if working to throw something from their head. It is said that fat sheep are often attacked without being injured—the worm finding plenty of food in the nostrils, does not ascend to the head and therefore does little injury.

Preventives.—Smear tar on the nostrils of the sheep several times during the summer months; or, what is much easier, though perhaps not quite so effective, is to place tar beneath the salt in the trough in which the sheep are salted. In licking the salt the sheep will smear their nostrils with the tar, which will prevent the fly from depositing its eggs, and any little tar they may eat will do no harm but rather good.

There are a great many remedies recommended for this disease. Snuff, blown forcibly into the nostrils with a quill, is very effective; but it is a slow and disagreeable process. Tobacco smoke blown up the nostrils by placing the stem of the pipe high up in them, and blowing by some means through the bowl, thus forcing the smoke into the cavities of the head. A tea-spoonful of spirits of turpentine and olive oil, in equal proportions, poured up each nostril, is said to be good. We like the following remedy the best: Take 4 oz. of Scotch snuff and pour over it a quart of boiling water; stir it well, and when cold take a syringe and inject about a table-spoonful up each nostril. The sheep should be placed on its back, and with the head on the ground. Force the mixture as much as possible into the cavities of the head, keeping the point of the syringe inclined upwards for this purpose, or the liquid will be apt to fall into the throat. It will make the sheep very

drunk, but nothing need be apprehended, even though they appear in the agonies of death, as they speedily recover.

The operation should be repeated in a week or ten days, so that if there are any of the worms in cavities where they escaped the dressing, they will probably in that time have changed their positions and the second dose will be likely to remove them.

MIXING ASHES WITH MANURE.—Please inform me whether the incorporating of unlixivated house ashes with stable manure, in a cellar under a barn,—in which barn horses and cattle are kept winter and summer,—the cellar being perfectly protected from rain or spring water, also from the sun,—would be beneficial or detrimental to the value of the manure if gradually mixed as the ordinary fires of a farm-house would produce them? Would, or would not, the alkali set free the ammonia? CHARLES BOOTH.—*Elizabethtown, C. W.*

Unleached wood ashes will in all cases decompose salts of ammonia where there is sufficient moisture present, and liberate the ammonia, which escapes into the atmosphere and is lost. So that when ashes or lime are mixed with fresh liquid or solid excrements, the lactate, urate, phosphate, and muriate of ammonia, which it contains will be immediately decomposed and easily detected by the strong, pungent, well known smell of hartshorn. Mix a pint of fresh lye with some unleached ashes, and see if it is not so. The reason of this action is, that the alkalies (potash, soda, &c.), of the ashes, have a stronger attraction for the acids with which the ammonia is united, than the ammonia has; so that they take away these acids and the ammonia is left free and being much lighter than air it flies off unless stopped by some absorbent substance.

CORN GROUND WITH THE COBS FOR FOOD.—Corn is used extensively in this country, in feeding to stock, crushed and ground in the cob. I have had my doubts of there being much nutriment in the cob after the corn becomes dry and think cut straw much better to mix with the clean meal. I would be pleased to have your views on the subject, or some of your able correspondents. SAM'L SATTERFIELD.—*Pulaski, Pa.*

We have always had our doubts of the economy of grinding the cobs with the corn, for feeding stock. *There is little or no nourishment in the cobs,* and the millers generally charge as much for grinding a bushel of corn in the ear as they do for a bushel of shelled corn, so that instead of the grinding costing only a tenth, it amounts to one-fifth of the corn ground. We think, with our correspondent, that it would be better to shell the corn and then mix meal with cut hay, corn-stalks, or straw—it costing less to remove the cobs than to grind them. It would be of great advantage to most farmers to have a crushing mill of their own, to be worked by hand or horse power, and then they could crush oats, corn, and every thing they feed to horses or cattle, for a mere trifle, and would find the advantage of such a course.

LEICESTER AND SOUTH DOWN SHEEP.—As your paper seems to be a sort of medium for farmers to obtain information through, I wish to inquire which are the most profitable sheep to raise, for the double purpose of wool and mutton—the Leicester or South Downs? Wool is worth about as much here as in Western New York, and mutton about three cents per pound. The general grade of sheep here is native, mixed with Merino, Panlar, &c. There are very few Leicesters and South Downs. I have a few Leicesters. The question here is, whether they are long lived, healthy, fatten easy, and what their relative value is over other breeds of sheep? If you would give the desired information, I should feel much gratified. C. M. DEWEY.—*Cambridge, Mich.*

There are as many different opinions on this question as there are different breeds of sheep. The Leicester grow larger, the wool is longer, and they are supposed to fatten quicker than the South Down. But the wool and mutton of the South Down is of a superior quality to the Leicester; and South Downs stand cold wet weather better than the Leicesters. If mutton is worth only three cents per pound, we are not sure but the fine woolled would be the most profitable breed.

PLOWING IN OATS AS A MANURE FOR WHEAT.—I have sown a field in oats which I intend turning in just before they head out, and when sufficiently rotted I wish to plow again and sow in wheat. Will you, or some of your correspondents, inform me through your columns whether such a course will be likely to pay the expense of the seed oats and two extra plowings that it will necessarily require. B. A. OVERMAN.—*Salem, Ind.*

None of the cereal grain crops, such as oats, corn, rye, timothy, or buckwheat, should ever be sown for the purpose of plowing in as a manure for a wheat crop, inasmuch as they are supposed to extract from the soil more nitrogen than they contain when plowed under; and as the wheat crop specially requires nitrogen, such a course should never be adopted. Unless the soil is light and sandy, a summer fallow would do more good, cleaning the land in the bargain. Peas and clover plowed in when in bloom, are the best green crops to grow as a manure for wheat. [See "plowing in green crops," in the June number.]

(B. M. CONNELL, *Howard, Steuben Co., N. Y.*) Canada thistles are a troublesome weed, not only in your neighborhood, but in nearly all others. We know of no easy and effectual mode of exterminating them from a farm. They should never be allowed to go to seed; be careful to mow them round the fences, roads, and on any waste land. Cut your clover before any thistles in it have formed seed; mow all in your grass land and summer fallows; and be sure to let this be done early enough, for if the seed is formed at all it will grow as it matures, after it is cut. The only way to destroy it in such a case, is to burn the thistles.— In this way much may be done to remove Canada thistles from the country.

(Out West, *Hartford, Wis.*) Should think there

was no deficiency of lime in that description of soil, but if you get unleached ashes for the drawing only a few rods; it will doubtless pay you well to use them. They do as much good on wheat as other crops. The older they are and the more exposed to the atmosphere they have been, the better, as they are the more likely to have absorbed ammonia in the place of the removed potash and soda.

COAL TAR.—I notice an inquiry in the April number of the *Genesee Farmer*, by Mr. KENT, on the subject of applying coal tar to house roofs, and I think your explanations are not definite enough, so I propose to give my personal experience in the matter, and if you think proper you may publish it.

On one part of my house I have had the third roof put on, with the assurance from each of the mechanics that the roof would not leak; but they all proved failures. I then saw an account in the *Ohio Cultivator* of the use of coal tar for stopping leaky roofs, and from the directions I received in that, I commenced applying the tar—first boiling the tar merely for the purpose of putting it on hot, as I understood the directions. The consequence was, that the tar ran through the crevices like boiling oil, and also through the cracks in the plastering, injuring every article of household furniture which it touched. What did remain on the top of the shingles was constantly melting by the sun and running through the cracks.

Now this is the method which I pursued: I boil the tar until ebullition almost ceases (being very careful about letting it take fire, which it does as readily as boiling oil); I then procure a strong handled corn broom and cut off the end of the brush about one-half, making a very stiff brush, and then apply the tar boiling hot; the second coating apply a thick covering of clean sand, after which apply another coating of tar, each time boiling hot. I will warrant a roof that will last as long as the owner of the house, and perfectly water tight. It is necessary to let each coat of tar precede the other a week or ten days. REV. N. WOOD.—*Chippewa, Ohio.*

ASHES ON POTATOES.—**POTATO FLY.**—I desire some information in relation to what, in this country, is called the "Potato Fly," "Shaver Bug," &c.—the best manner to combat them, or to prevent their ravages.

I would just say to your correspondent, E. HAMMOND, that my experience and observations, in relation to the application of leached ashes to potatoes, are quite the reverse of his. I never have had a rotten tuber where ashes were applied while planting. I drop the potato, then apply ashes; and finally cover with loose earth. I do not consider ashes a preventive. I hope others will give us their experience. J. W. J.—*Lawrence Co., Ind.*

GROUND MOLES.—We are very much troubled with a Mole, commonly called Ground Mole, in this section. If you, or any of your numerous subscribers, can inform me of any practicable method of catching or destroying them, I shall feel under renewed obligations to the *Genesee Farmer*. NICHOLAS HAIGHT.—*Edford Station, N. Y.*

NEW OXFORDSHIRE SHEEP.—Can you, in your replies to correspondents, inform me where the New Oxfordshire sheep can be found, and the probable price of a pair of lambs or yearlings—say a buck and ewe. SAM S. BEAMAN.—*Hampton, Wash. Co., N. Y.*

HORTICULTURAL.

(S. S. R., Harrison.) **ROOT GRAFTING**—Is usually performed on young roots about one-quarter of an inch in diameter at the collar where the graft is inserted. The common mode, is whip or tongue-grafting—a sloping cut about an inch long is made on both root and scion; both are tongued alike and fitted one into the other so that their surfaces are in close and even contact, and their bark at least on one side fitted together. A bandage of some slight material, tow, waxed paper, &c., is applied to keep the graft in its place, and the work is done.

Budding—is performed during the growing season, and when the buds on the current year's shoots are perfectly formed and mature. The bark on the stock is raised and a bud from the scion or shoot of the same season is taken off, with half an inch of bark above and below attached, and inserted. A bandage of some elastic material, bark, woolen yarn, &c., is applied. This is but a rough outline of the proceeding. You ought to procure some of the various treatises on tree culture. Apple, pear, peach, or plum scions, cannot be planted so as to grow; but the small fruits, grapes, currants, gooseberries, &c., can.

(LUKE PUNSHON.) Ivy plants can be obtained at any of the principal nurseries where ornamental plants are sold.

(S. T. R., Marion, Wis.) We have seen cherry trees saved, which have been split by hard frosts, as you describe yours to have been, by being wrapped up in a straw covering until the wound healed up during the following summer. The course you have taken will no doubt save yours if you do not uncover them too soon.

(P. M., Cedarville.) Scions from a sweet apple tree will produce sweet fruit, even if grafted on a sour apple stock. The stock has no such influence on the scion as to change it from sweet to sour, or from sour to sweet, though it does produce certain modifications, in both wood and fruit, in the same way as certain soils do. A bud or graft from any particular variety never loses its identity, no matter on what grafted or budded, no more than a plum would become a peach when budded on peach stock, or a pear become a quince when on a quince stock.

Budding can be performed any time from July to September. Get some of the various treatises on tree culture. It is all a fable about producing a sweet and sour apple by inserting a sweet and sour apple bud together.

(A. J. H., New Fane.) The insect is the "Ap-

ple Worm." It enters at the blossoms and eats to the core. The most effectual and simple remedy is to pick up and destroy the wormy fruit as fast as it falls. If swine are allowed to run in orchards, they will do this.

(L. B., Out West.) **BIRDS**.—We concur in the opinion that troublesome as birds are in some cases, they are yet a blessing in destroying myriads of destructive and annoying insects. Powder and shot may be occasionally resorted to for the purpose of saving a crop of fruit, especially in woody districts where birds are very numerous and fruit very scarce.

PARADISE STOCKS, for dwarfing apples, are usually sold in the nurseries at \$2 or \$3 per 100. All the best varieties we have so far tried, succeed well on it. The *Red Astracan*, *Gravenstein*, *Canada Reinette*, *Fall Pippin*, *Keswick Collin*, *Summer Rose*, are choice sorts that do remarkably well. In dwarfing, the bud or graft should always be inserted *near* the ground, for the reason that it usually outgrows the stock.

(J. H. C., Darien, Ct.) Thorn seedlings are generally to be had in the nurseries. We have not much experience in working the pear upon them, but have succeeded well with *Buffum*, *Seckel*, *Marie Louise*, &c., on the American species. The quince is better. *White Doeyenne*, *Louise Bonne de Jersey*, *Duchess d'Angouleme*, *Bartlett*, *Belle Lucrative*, *Year of Winkfield*, and *Glout Moreau*, are among those that succeed remarkably well. Budding is better than grafting.

(A. D. SOUTHWICK, JUNIUS.) Fine samples of *Red Canada*, or old *Nonsuch*.

(T. J. M., Bayfield, C. W.) The wild cherry is not suitable for a stock, especially for the *Hart* and *Biggervau* varieties. The sour, or *pie* cherry, is better, but neither buds or grafts take well upon it. *Mazzards* can be had cheap in the nurseries.

(W. G., Phoenix, Pa.) We cannot account for the bark becoming loose on your plum trees, and the wood of the body being dead while the head is living and in blossom. We have not seen such a case. It may be the bark was split open by the severe frosts and thus the body killed. This would not prevent the top from showing leaves and blossoms.

(H. B. S., Rockport.) **EVERGREENS**.—You can get young plants of native species from the woods in the months of May and June. Seeds of all hardy kinds may be sown in June, in a cool shaded north border, or in boxes of earth in such situations. The seeds are sown as you would carrots, beets, or any common garden seeds, in fine earth and slightly covered.

GREAT SALE OF BLOOD CATTLE.

ON Wednesday, the 15th of August next, I will sell the chief part of my large herd of Blood Cattle—chiefly cows, heifers, and heifer and bull calves—comprising upwards of fifty full-bred Short-Horns.

Also, eight thorough-bred Herefords—a two years old bull, a yearling bull, three cows, and three calves. One of the Hereford cows ("Barly") was imported from England by Messrs. Corning & Southam, in 1811. The others, excepting the two years old bull, are her descendants, by bulls of the same stock.

Also, two or three Devon bull calves, got by Mr. Ambrose Stevens' imported bull "Candy," bred by the distinguished Mr. Quarry, of Devonshire, England, and out of cows descended from the herd of the late Earl of Leicester.

The remainder of the cows and calves, forty to fifty in number, are high-bred Short-Horn grades, with a dash of Devon blood in some of them.

The calves of the thorough-bred Short-Horns and grade cows, are mostly got by the imported Short-Horn bull "Duke of Exeter," (10,152.) of the celebrated "Princess tribe," bred by Mr. John Stephenson, of Durham, England, whose herd is excelled by none, if equalled, by any now in England.

All the Short-Horn and grade cows and heifers which come in season, will be bulled, previous to the sale, by "Duke of Exeter."

Many of the cows, both thorough-bred and grade, are descended from the Bates bulls "Duke of Wellington," imported by George Vail, Esq., of Troy, N. Y.; and by "Symmetry," son of "Wellington," out of Mr. Vail's imported Bates cow "Duchess."

This stock has been bred with a strict regard to their milking quality, in which they have been fully proved, and are not excelled by any herd of cows in the United States. They are all gentle, with fine silky udders, milk easy, and are animals that will be satisfactory to any one in want of the best breeding and milking stock.

The sale will take place at the residence of Peter Gurbaine, two miles above Albany, on the Troy road, on the homestead farm of Gen. Van Rensselaer, where the cattle will be for a week before the sale.

Catalogues with pedigrees will be prepared by the 15th of June, and sent by mail to all post-paid applicants.

I will also sell at the same time, two pairs of six years old thorough-bred Short-Horn oxen, and two or three pairs of matched steers.

Also, ten or twelve South-Down buck lambs, got by an imported ram, from the unrivalled flock of Jonas Webb, of Babraham, England, and from Ewes descended from the flocks of Mr. Webb, and Mr. Eilman of Sussex.

LEWIS F. ALLEN.

Black Rock, N. Y., May, 1852.—6-31*

Fruit Farm in Ohio for Sale.

"POMONA FARM"—120 acres of excellent land; 50 acres young orchard, containing 8000 peach and 2000 apple trees of the choicest market varieties, commencing to bear, and partly enclosed with Osage Orange hedge. About 40 acres is woods pasture with living water. The soil is strong loam, well adapted for grain and grass, as well as fruit—was especially designed for fruit, stock, and poultry—about 100 improved fowls are on the premises. The buildings are of little value. The situation is very healthy and pleasant; good water; schools and other social advantages convenient.

The farm is situated at the thriving village of West Jefferson, 14 miles west of Columbus, at the intersection of the "National Road," the "Xenia Turnpike," and the "Cleveland, Columbus, & Cincinnati Railroad"—only 100 rods from the village and depot—thus affording excellent facilities for travel and transportation, with certain markets for products. It will be sold at a bargain.

Address M. B. BATEHAM,
Editor Ohio Cultivator, Columbus, O.

June 1, 1852.—6-21*

Improved Stock.

CATTLE of the Durham, Devon, Hereford, Alderney, and Ayr. hire breeds.

SHEEP of the Native and French Merino, Saxony, South Down, and Cotswold.

PIGS of the Lincoln, Suffolk, and Berkshire breeds.

From our long experience as breeders and dealers in the above kinds of stock, and our excellent situation for purchasing and shipping, we think we can do as good justice to orders, as any other house in the United States.

A. B. ALLEN & CO.,
April 1, 1852.—d. 189 and 191 Water st., New York.

New York Agricultural Warehouse,

189 & 191 Water Street, New York.

A. B. ALLEN & CO.

HORSE POWERS, Threshers, and Separators. The Endless Chain or Railway Powers of our own manufacture, both single and double geared, for one and two horses, which has never been equalled for lightness in running, strength, durability, and economy. They are universally approved wherever they have been tried.

2d. The Bogardus Power, for one to four horses. These are compact and wholly of iron, and adapted to all kinds of work.

3d. Eddy's Circular Wrought-Iron large Cog Wheels, for one to six horses. A new and favorite power.

4th. Trimble's Iron-sweep Power, for one to four horses. **THRUSHERS**—Improved Thrushers made upon the best principles, threshing clean with great rapidity.

FAN MILLS for Wheat, Rye, Oats, &c., of the best construction.

RICE FAN MILLS made expressly for the South.

MILK PANS—Glass and Enamelled Iron Milk Pans, very desirable articles.

CHURNS—Thermometer, Atmospheric, Kendall's, and other kinds.

HAND CULTIVATORS and Hand Plows—are very useful implements in garden culture.

SCYTHES—Grass, Grain, Bush, and Lawn Scythes of the best kinds.

RAKES—A large assortment Steel, Iron, and Wooden-headed Garden Rakes, and Lawn and Hay Rakes.

HOESE HAY RAKES of new and highly improved patterns.

REAPING and MOWING MACHINES—These have been fully tested, and embrace many late improvements, and we can highly recommend them.

GARDEN and FIRE ENGINES, very useful machines, arranged on wheels, for watering gardens or walks, and affording protection from fire. They will throw a strong stream forty feet high, are easily worked, and not liable to get out of order. Also, small Garden Pumps and Syringes of various styles.

HAY and COTTON PRESSES—Bullock's Progressive Power Presses, combining improvements which make them by far the best in use.

WATER RAILS, Suction, Force, and Endless-Chain Pumps; Leather, Gum-Percha, India-Rubber Hose, Lead Pipe, &c.

CABBAGE PLOW—Very light and convenient for working among cabbages.

POTATO PLOW, with double mould and other forms for hilling and weeding.

Our Implants occupy three large stores, and we believe they make up the largest and most complete assortment in America. In addition, we have a machine shop, employing upwards of one hundred men, where any articles in our line can be made to order.

A. B. ALLEN & CO.,

June, 1851.—6-1f. 189 and 191 Water St., New York.

French Zinc Paint.

THIS new and beautiful article of Paint is now offered to the trade and public, ground in prepared linseed oil, for the first time in this country. It has been used successfully in France for the last five years, where it has superseded white Lead as a paint.

The French Zinc when properly prepared and used, makes the most brilliant and durable white in use, and is entirely free from all poisonous qualities.

The French Zinc is not more expensive than white lead, and is prepared in such a manner that it requires no farther preparation for use, than to thin it with Turpentine or raw Oil to the consistency of white lead paint.

The French Zinc is very much whiter, and has a better body, than the New Jersey Zinc.

The French Zinc is offered dry, and prepared as above, in quantities to suit purchasers, at the Manufacturer's Depot, No. 17 Buffalo st., Rochester, N. Y.

July, 1852. M. F. REYNOLDS.

Improved Subsoil Plows.

THE subscribers offer for sale an Improved Subsoil Plow, made under the advisement of Prof. J. J. Mapes, and free from the objections urged against those formerly in use. The wearing parts are so arranged that they may be easily and cheaply renewed, while the amount of force requisite to move them is less than half that required by those previously made.

Price—One Horse Plow, \$5; with draft rod, \$6. No. 1, with draft rods, \$8.50. No. 2, do. \$11.

LONGETT & GRIFFING,
June, 1852.—6-3f. No. 25 Cliff street, New York.

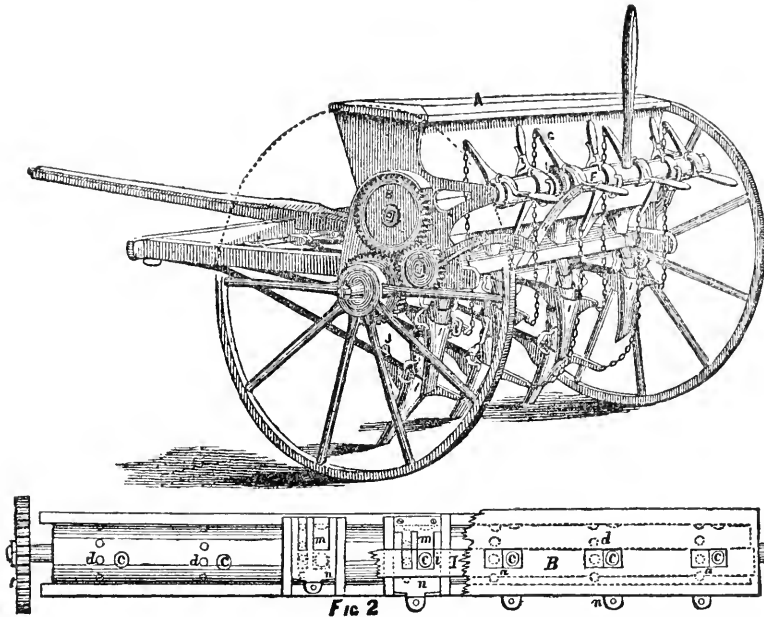

SUPERIOR GRAIN DRILL.

MANUFACTURED BY

Bickford & Huffman, Macedon, Wayne Co. N. Y.

THE above celebrated Machine has, during the past year, been more extensively introduced than any year previous, and what is most gratifying to the manufacturers, they have given most unqualified satisfaction. Double the usual quantity has been sold during the past year, mostly of nine tubes, without supplying the demand for them.

After several years experience, with our present increased facilities for their manufacture, together with some additional improvements in their construction, they are now offered to the public with increased confidence in their superiority over all other Grain Drills now in use. The grain is distributed by the means of a cylinder operated by different sized gear wheels for the purpose of distributing the quantity desired. We are manufacturing them with the drill tubes differently arranged, some with two parallel rows, the front row being seven inches forward of the back row, sowing the rows seven inches apart, thereby facilitating the passage of the drill tubes among stones and clods. Others are arranged in one row, eight inches apart; or we will manufacture them to order with the tubes arranged any distance apart required. Those ordering drills will please be particular and mention the kind they prefer. Of the great number sold, not one has been returned, although each is warranted to sow all kinds of grain with accuracy and satisfactory to the purchaser, and to be made in a workmanlike manner. Subject to this warrant, we respectfully solicit the patronage of the public, with a full conviction that they will be fully satisfied, on a fair trial, of the merits of this useful implement.

Orders for drills should be sent in early, directed to us, or to

- DANIEL SUPPLE, Dundee, N. Y.;
- ALFRED HALE, Alloway, N. Y.;
- H. W. LEVANWAY, Lock Berlin, N. Y.;
- C. L. MARSHALL, Sparta, N. Y.;
- AMOS WILLETS, Aurora, N. Y.;
- JOHN KING, Genoa, N. Y.;
- JOHN C. HALL, Hornersville, N. Y.;
- MCLALLEN & HESLER, Trumansburg, N. Y.;
- Col. J. M. SHERWOOD, Auburn, N. Y.;
- WATERMAN & JACKSON, Vienna, N. Y.;
- JAMES H. GLASS, Geneseo, N. Y.;
- DAVID VER VALIN, Poughkeepsie, N. Y.;
- J. H. BUTTERFIELD, Utica, Mich.;
- B. B. DEXTER, Batavia, Ill.;
- ABNER WING, Geneva, Wis.

Price of Drills—\$65 for seven tube Drills; \$75 for nine tube Drills, delivered at the Canal or Railroad.

All orders thankfully received and promptly attended to.

BICKFORD & HUFFMAN.

Macedon, N. Y., July, 1852.

TRIAL OF IMPLEMENTS

By the New York State Agricultural Society, JULY 1852, AT THE VILLAGE OF GENEVA.

THE trial of Grain Reapers, Mowing Machines, Steam Engines for farm purposes, Grain Drills, Horse Powers, Flax and Hemp Dressing Machines, Thrashers, Seed Planters, Cultivators, and Broadcast Sowers, will take place at Geneva, between the 12th and 26th of July next. (The particular day of the commencement of the trial will be given hereafter.) The competition will be open to all who become members of the Society, and enter their machines for trial.

Upwards of \$400 will be awarded to the successful candidates; and Inventors are invited to be present with their machines, and engage in this trial, which will be conducted in a manner to secure practical and reliable results, that will be of importance to the whole agricultural interest of the country.

Persons desiring to compete must become members of the Society by the payment of \$1, and enter their names with the Secretary by the 5th of July, and their implements.

All desired information as to the regulations for the trial will be furnished on application to the Secretary.

B. P. JOHNSON, Secretary.

Agricultural Rooms, Albany, May, 1852.

Field Seeds.

AUSTRALIAN WHEAT—very superior. The berry of this grain is extra large, and makes the best of flour. It produces a greater average crop than any other variety now grown in New York. Several years' experience in its cultivation, proves that it is less liable to rust or mildew than other kinds; and as the stalk is large and strong, it is also less liable to blow down or lodge. Price, \$4 per bushel. Other varieties of wheat, such as the White Flint, Mediterranean, Black Sea, &c.

BUCKWHEAT, of the best kinds in market.

RUTA BAGA, or Swedish Turnep Seed. The Purple Top and other superior varieties.

TURNEP SEED—Large White Flat, Long White, Red Top Flat, Yellow Aberdeen, Yellow Stone, and other improved kinds for the field or garden. A. B. ALLEN & CO., June, 1852.—6-11. 189 & 191 Water st., New York.

Prices of Agricultural Products at the Principal Markets in the United States. — June 18, 1852.

	New York.	Boston.	Rochester.	Chicago.	Cincinnati.	Philadelphia.
Beef, per 100 lbs.	a \$7.50	a \$7.25	\$5.50	a 6.00		
do mess, per bbl.	11.00 14.50	11.00 15.50	10.00 10.50			\$16.00 a 16.50
Pork, per 100 lbs.			7.00 7.50			
do mess, per bbl.	18.50 19.50	18.50 22.00	16.00 19.00	\$16.50 a 17.00	\$16.50 a 17.00	19.00
Lard, per lb.	10 11½	10 12½	9 9	8 9½	8 10¼	10½ 11½
Butter, do	12½ 19	15 25	12½ 9	8 10	8 12	14 16
Cheese, do	6½ 8	7 8½	6 7	5 7	6¼ 6½	
Flour, per bbl.	4.00 5.75	4.12 5.75	4.62 4.75	2.75 4.00	3.15 3.20	4.12½ 5.00
Wheat, per bush.	90 1.15	90 1.05	93 1.01	71 76	62 64	95 1.05
Corn, shelled, per bu.	62 64	60 65	54 56	31 36	30 30	60 64
Rye, do	40 44½	75 80	69 70		47 50	75 75
Oats, do	60 64	41 43	40 41	18 23	23 25	49 49
Barley, do			67 70		33 50	
Clover seed, do	7½ pr. lb.	8 a 11 per lb.	5.50		3.75 4.00	4.12½
Timothy seed, do	\$14 to 16 per c.	2.50 2.75	2.25 3.00	2.25	1.50 2.50	
Flax seed, do	1.20 1.30	1.33 1.35	1.25 1.50	1.00	1.00	1.25
Hay, per ton.	11.50 12.00	14.00 15.00	8.00 12.00		7.50 15.00	
Wool, per lb.	26 43	33 41	24 35	18 28	22 30	
Wood, hard, per cord		5.25 6.50	4.00 4.50			

CONTENTS OF THIS NUMBER.

Suggestions addressed to State and County Ag. Societies 201
 Salt your Hay..... 202
 The Philosophy of Nutrition..... 203
 Cutting food for stock..... 205
 Soot as a Fertilizer..... 206
 Management of Barn-yard Manure..... 208
 Cheese making from a small dairy..... 209
 Ruta Baga and Common Turnep culture..... 210
 A few words on growing Clover Seed..... 211
 The proper time to cut Wheat..... 212
 Woodman, Spare that Tree..... 212
 CONDENSED CORRESPONDENCE.—How to Prevent Cuckers from being Destroyed by the Striped Bug, 213
 Bee Knt; A good Cow..... 213
 Unleached Ashes on Potatoes; Patent Galvanized Iron; Virginia Land..... 214
 LADIES DEPARTMENT.—Annual Flowers..... 222
 EDITORS' TABLE.—Premiums; Monroe Co. Plowing Match..... 223
 Letter from Mr. Liebig; Giving Credit..... 224
 Agricultural Fairs, Notices, &c..... 225
 Inquiries and Answers..... 225

HORTICULTURAL DEPARTMENT.

Spring Flowering Trees and Shrubs..... 216
 Bulbs for July..... 217
 Pears on Quince Stocks..... 218
 Hand-Book of Vines..... 219
 Horticulture in Philadelphia..... 219
 Letter from Crawford County, Pa..... 220
 American Pomological Congress..... 220
 Horticultural Society of the Genesee Valley..... 221
 Peach Trees..... 221
 Strawberries..... 221

ILLUSTRATIONS.

Flowering Ash..... 216
 The Snowdrop..... 217
 The Salpiglossis..... 222
 The Petunia..... 223

Emery & Co.'s Improved Horse Powers, Threshers, and Separators.

THE undersigned have been appointed sole agents for the sale of Emery's new Patent Improved Horse-Powers, Threshers, and Separators, in the city of New York. The State Agricultural War-house is the only depot where this superior Power can be had.

LONGETT & GRIFFING,

7-f. State Ag. Warehouse, 25 Cliff st., New York.

Atbany Tile Works,

No. 60 Lancaster St., West of Medical College.

THE subscriber has now on hand, and is prepared to furnish to Agriculturists, Horse-Shoe and Sole Tile, for land drainage, of the most approved patterns. They are over 1 foot in length, 2¼ to 4½ inches calibre, from \$12 to \$15 per 1000 pieces—being the cheapest and most durable article used. Orders from a distance will receive prompt attention. [1-61] JOHN GOTT, Jr.

Northern N. Y. Live Stock Insurance Company, Plattsburgh, N. Y. For terms, please apply to agents of the Company.

THE subscriber deals in, and sells on commission, all kinds of good patents. Worthless ones need not be offered.

A good Grass Mower wanted. The best of reference given. ALLEN VANE, No. 157 South Water Street, Chicago, Ill. April 10, 1852.—5-3t.

Morgan Stock for Sale.

THE subscriber offers for sale, at Auction, on the 18th day of August next, at Scottsville, N. Y., at 10 o'clock, A. M., a very fast traveling mare valuable for breeding, in foal by the celebrated Vermont Morgan horse "Gen. Gifford," who was awarded the first premium on Morgan horses at the N. Y. State Fair in 1851.

Also, "Zachary Taylor," two years old in June, and "Gifford Morgan," four years old in August,—both bay studs by above named horse and mare, suitable for matching or stock.

Gifford Morgan will be exhibited at Spencer's Exchange Hotel, Rochester, on the 10th of August.

Terms—Cash, or approved notes at one year, with interest. Scottsville, N. Y., 1852. [7-21] J. DORR.

Real Estate for Sale.

THE health of the subscriber having failed him, he is induced to offer for sale his Mill property, consisting of a custom Mill, recently put in a good state of repair; a Saw Mill, also recently repaired; two Dwelling Houses; a good Orchard, and about 22 acres of land, including flowage land. Said property is situated in the pleasant town of Yates, Orleans Co., N. Y., in the midst of a wealthy farming community and an excellent wheat growing country.

He has also a farm of 154 acres of first quality land adjoining said Mills, 120 acres improved, good buildings, orchards, and plenty of running water. He will sell said farm with the Mills, if desired.

Inquire of the subscriber, on the premises. [7-31] J. C. PARSONS.

THE GENESEE FARMER, A MONTHLY JOURNAL OF AGRICULTURE AND HORTICULTURE,

VOLUME XIII, FOR 1852.

DANIEL LEE & JAMES VICK, Jr., Editors. P. BARRY, Conductor of Horticultural Department.

Fifty Cents a Year, in Advance.

Five Copies for \$2—Eight Copies for \$3, and any larger number at the same rate.

All subscriptions to commence with the year, and the entire volume supplied to all subscribers.

Subscription money, if properly enclosed, may be sent (post-paid or free) at the risk of the Publisher. Address to

DANIEL LEE,

December, 1851. Rochester, N. Y.



WHEAT CULTURE IN NEW ENGLAND.

MUCH has been written, first and last, on the practicability and profit of growing wheat in New England, and particularly in Massachusetts. At this time, the Rev. J. A. NASH, of that State, is discussing the subject in the columns of the *Amherst Express*, in which we find several interesting statements, but none of them entirely satisfactory. They all fail to inform the reader of the value of the elements of fertility removed from the soil in producing a good crop of this grain. The following account, taken from the *Transactions of the Hampden Agricultural Society*, is instructive, and doubtless reliable, so far as it goes :

“HORACE SMITH’S STATEMENT.—The crop of wheat which I offer for premium, was raised on seven and a half acres of land; the soil an alluvial sandy loam. The land was well prepared and planted with corn in the spring of 1850, and harvested an excellent crop, which was cut up and carted from the ground by the middle of September. We then commenced for the present crop, by dragging the land, (to level the corn hills,) which prepared it for the plow. This immediately succeeded, and on the 25th of September the seed was sown at the rate of one bushel and a half per acre, which was harrowed in and the land rolled. In July, 1851, the wheat was harvested, has been threshed, cleaned, and sold for \$1.10 per bushel.

The product was 236 bushels, amounting to.....	\$259 60
Eight tons straw, \$6 per ton,.....	45 00
	\$307 60
Expenses for dragging the land for plow,.....	\$2 20
Plowing,.....	9 87
Seed, 11½ bushels, at \$1.50 per bushel.....	16 87
Sowing, harrowing, and rolling,.....	4 00
Harvesting, at \$1.25 per acre.....	9 87
Threshing and cleaning,.....	9 00
Cartage to market.....	3 00
Land rent, \$10 per acre,.....	75 00
	\$128 81
Net gain,.....	\$178 79

Being a clear profit of twenty-three dollars and eighty-three cents per acre.”

If a ton of wheat straw is worth six dollars, what is the value of a ton of good manure? What will it cost to give back to these seven and a half acres as much of vegetable mold, ammonia, soluble silica or flint, phosphoric and sulphuric acids, chlorine, potash, soda, lime, and magnesia, as was removed by tillage, irrespective of what the wheat plants consumed in growing, as well as all that the crop contained?

We hope that Mr. NASH will investigate this point, which for some reason has been too long overlooked by practical farmers. It is easy to understand how land made rich to yield a large crop of corn, may produce immediately after it an excellent and apparently very cheap crop of wheat. BOUSSINGAULT describes land on which wheat had been successfully cultivated every year for two centuries, by the aid of manures. The annual overflow of the Nile is said to fertilize the soil sufficiently to yield annual crops of wheat, with as much certainty as inundated meadows on the Connecticut river yield

good crops of hay without any manure. The full and perfect renovation of the depauperated earth from which generous harvests have been gathered, is an object of the first importance with every considerate agriculturist. To neglect this professional duty shows that the first elements of wise and successful husbandry are either unknown or repudiated.

We believe that wheat-culture can be made profitable in Massachusetts, and the other New England States, to the extent of growing all that is needed for home consumption. In addition to all the manure that can be made on the farm, guano is now cheap enough, judging from its effects in producing wheat on the poor lands of Delaware, Maryland, and Virginia, to assist the wheat-growers north of Delaware quite as much as it does south of the Hudson river. There is no good reason why this highly concentrated fertilizer should be less valuable in grain-culture when used in Massachusetts, New Hampshire, Vermont, and Maine, than in New Jersey, Delaware, Maryland, Virginia, and North Carolina. Guano has more than doubled the value of thousands if not millions of acres in the States last named. Our New England friends will do well to experiment with this manure in growing wheat and corn more than they have hitherto done. Alone, it will fail to produce good wheat after the alkalies are measurably washed out of the soil by long tillage without adequate restitution; for 300 lbs. of guano does not supply as much potash as an acre of land parts with in bearing a fair crop of wheat. The remedy is to apply occasionally a few bushels of good ashes per acre. Where ashes are not to be had, clay that contains considerable potash, or greensand, may be used as a substitute, particularly on sandy, gravelly, and porous soils. Good virgin clay always abounds in the elements of fertility in a dormant or nascent state. These alimentary substances are brought out and rendered available by the mechanical and chemical effects of tillage. There are many advantages in resorting to fat clay to obtain the mineral food of plants. First, Clay costs nothing but the labor of subsoiling, or of hauling a short distance. Secondly, The light and heat of the sun, the frosts of winter, the oxygen and carbonic acid of the atmosphere, and the rains and dews that fall upon every square foot of land, are invaluable in developing the latent powers of rich clays; and they too cost nothing. As we have heretofore repeatedly stated, by slightly charring clay and adding a little caustic lime, whatever potash, soda, phosphoric and sulphuric acids it may contain in a before insoluble condition, will be brought out more speedily by this operation. The presence of lime in considerable quantity imparts to limestone lands, the world over, a higher reputation for wheat-culture than attaches to soils nearly destitute of calcareous matter. This is a fact of great significance, and one that our eastern and southern friends should carefully ponder. It is true that lime alone will not produce wheat, nor any other crop; but it is an indispensable element in all fertile land, and one that is lacking in more than a moiety of the cultivated farms in the United States.

No crop shows the skill of the farmer to better advantage than that of wheat. Let him plow deep and stir all the earth, harrow thoroughly, subdue all grass, bushes, briars, and weeds, where they exist, and the crop will command the full benefit of whatever strength the soil may naturally possess, so that if manured at all, a little may go far in augmenting the harvest. Much depends on giving fertilizers the best possible chance to aid in the growth of cultivated plants. On well tilled land manure does twice the good that is realized on badly cultivated fields; and yet, many farmers seem to believe that a ton of guano, or stable manure, should do all in producing grain, no matter how poorly the soil is cultivated.

Profit and loss in rural affairs are not studied so closely and accurately as they ought to be, and must be, to attain the highest success. Not until the raw materials of crops, as they exist in the surface of the earth, are entirely familiar to the husbandman, can he husband them with the best economy. To do this, he must know how to work up the things that make grain, grass, roots, tubers, fruits, and timber, with the least loss of his capital in the soil.

NATIONAL AGRICULTURAL CONVENTION AND SOCIETY.

A NATIONAL AGRICULTURAL CONVENTION assembled in the Lecture Room of the Smithsonian Institution at the federal metropolis, on the 24th of June last, in compliance with a call for that purpose signed by the Hon. MARSHALL P. WILDER, of Massachusetts, and the Presidents of a majority of the State Agricultural Societies in the Republic. The leading object of the Convention was to establish a National Agricultural Society; which object, we are happy to say, was fully accomplished, by calling into existence "The United States Agricultural Society."

Those who are seriously engaged in the great work of improving American tillage and husbandry in all the States and Territories which compose the Union, have long felt the want of some efficient national organization that would bring the friends of agriculture everywhere to act in concert for the attainment of a common purpose; but our country is so extensive, stretching from the Atlantic to the Pacific, and farmers have so much to do and look after at all times, and especially in the busy month of June, it was naturally feared that no object so public in its character as the formation of an agricultural society, avowedly to embrace the whole United States, could draw out a respectable delegation from a majority of them, to consult together in convention. But thanks to the agricultural press and the intelligence of the people, they are ready to sustain any well-considered plan, no matter how comprehensive, for the collection, increase, and diffusion of agricultural knowledge. The truth of this remark was demonstrated in the appearance of 152 delegates in Washington, many of whom had come several hundred miles at much personal inconvenience and expense, and for no other purpose than to attend the agricultural convention, and discharge what they regarded as a high public duty. Twenty-three States and Territories were represented.

The Convention was organized by calling Judge FREDERICK WATTS, President of the State Agricultural Society of Pennsylvania, temporarily to the chair, and appointing R. S. MERCER, of Maryland, and DANIEL LEE, of the District of Columbia, Secretaries.

On motion, a committee of seven was appointed to nominate permanent officers of the Convention; from which Mr. KING, of Rhode Island, (Editor of the Journal of Agriculture,) submitted the following nominations:

For President—MARSHALL P. WILDER, of Massachusetts.

For Vice Presidents—HENRY WAGER, of New York; FREDERICK WATTS, of Pennsylvania; CHAS. B. CALVERT, of Maryland; WM. F. HUNTER, of Ohio; GEORGE W. NESMITH, of New Hampshire; JOHN H. THROCKMORTON, of Virginia; H. K. BUSBY, of North Carolina; T. J. RUSK, of Texas; JAMES DUANE DOTY, of Wisconsin.

For Secretaries—WILLIAM S. KING, of Rhode Island; B. P. JOHNSON, of New York; J. A. WARDER, of Ohio; J. D. B. DE BOW, of Louisiana.

The report having been unanimously accepted—

Mr. WILDER, amidst much applause, took the chair, and addressed the Convention as follows:

Gentlemen of the Convention:—I will not interrupt the proceedings of this body by any extended remarks by the chair; but I can not forbear to tender to you my heartfelt gratitude for the honor you have conferred upon me in selecting me to preside over your deliberations—an honor which is connected with a pursuit which has ever laid near my heart.

Permit me also to express my great gratification that there are present so many members representing the agricultural interest of this great Republic—some gentlemen coming from different and distant parts of the Union, at great personal sacrifice; but, whether from the north or the south, the east or the west, I extend to each of you the hand of fellowship, and I greet you as brothers in a common cause.

Gentlemen, we come here with no sinister motives; we have no political arguments to advance; we have no sectional or party purposes to promulgate: but we are here for more important purposes. We are here to advance an art coeval with the existence of the human race—an art which employs eighteen millions of our population, and four-fifths of all the capital in our fair land—an art which lies at the very foundation of all national and individual prosperity and wealth, the basis of com-

mere, of manufactures, and of industrial pursuits. We are an agricultural people; our habits, our dispositions, are rural. I rejoice that it is so, and I pray that it may ever continue to be so. Our country embraces every variety of soil, and is capable of producing most of the products of the torrid and temperate zones; and with a suitable application of science to this art, and a wise division of labor, with proper Governmental aid, there is no reason why American agriculture may not sustain competition with that of any other nation of the civilized globe.

The progress of agriculture, as you all know, gentlemen, has been slow in the United States; but a new era has now commenced. The old worn out systems of cultivation which have been followed by father and son, and from generation to generation, are now to be swept away, and science is to take its place in aid of honest industry. I rejoice, gentlemen, that we live at this day; I rejoice that the seed planted by the immortal WASHINGTON, and which has been watered by thousands of other eminent agriculturists, is now taking root, and that we live in our day to realize some of the proud results of their hopes.

Much of the progress which has been attained in our country is the result of individual enterprise, aided by the agricultural press; but the great motive power is confederated action—is associated effort. Gentlemen, we have met on this occasion to avail ourselves of this powerful impetus. At no period in the history of our country has there been such an assembly collected for the purpose of considering those objects for which we are brought together, and there has been no opportunity which is so favorable to the interests of the farmer.

Permit me again, gentlemen, to tender you my thanks for the distinction you have conferred upon me, and to say that in the course of our deliberations I may, with your permission, participate in your debates. [Applause.]

A committee composed of one from each State was appointed to draft a Constitution for a National Society, and prepare other business for the Convention. The following is a copy of the Constitution as reported by the business committee, which, with a few mere verbal amendments, is now the Constitution of the Society:

The undersigned, in order to improve the agriculture of the country, by attracting the attention, eliciting the views, and combining the efforts of that great class composing the agricultural community, and to secure the advantages of a better organization, and more extended usefulness among all State, County, and other agricultural societies, do hereby form ourselves into a society, and, for its government, adopt the following

CONSTITUTION.

Sec. 1. The name of this association shall be The United States Agricultural Society.

Sec. 2. MEMBERS—DUES.—The Society shall consist of all such persons as shall signify to any officer of the Society a wish to become a member, and who shall pay two dollars to the Treasurer of the Society, and a like sum annually hereafter; of delegates from the State agricultural societies in the States and Territories and District of Columbia, who may be appointed to attend the annual and other meetings of the Society, and who shall pay the like sum; and also of such honorary members as the Society may see fit to elect. Each member shall be entitled to receive a journal or publication of said Society, containing an account of its proceedings and such additional matter as shall be deemed worthy of publication, free from any expense except postage. Twenty-five dollars shall entitle one to the privileges of life membership, and exempt him from any annual taxation.

Sec. 3. OFFICERS.—The officers of this Society shall be a President, a Vice President from each State and Territory in the Union and from the District of Columbia, a Treasurer, a Corresponding Secretary, a Recording Secretary, and a Board of Agriculture, to consist of three members from each State, Territory, and the District of Columbia, to be appointed by the Executive Committees of the Societies of such States, Territories, &c., and where there are no such State Societies, to be appointed by the Executive Committee of this Society. The President of the Society shall be, *ex officio*, a member and President of this Board and of the Executive Committee.

DUTIES OF OFFICERS.—The *President* shall have a general superintendence of all the affairs of the Society. In case of his death or inability to discharge the functions of this office, the Board of Agriculture shall select a *Vice President* to act in his stead, and clothed with the same power, and shall perform the same duties as the President until the next annual election.

Vice Presidents.—It shall be their duty to advance all the objects of the association, in their several districts; to explain to agriculturists the character and objects of this association, and endeavor to obtain their co-operation and support; to watch the advance of practical agriculture, and to make known the results of the same, by report or otherwise, from year to year.

Board of Agriculture.—It shall be the duty of this Board to watch the interests of agriculture, as they are or may be affected by the legislation of the country, and to make such reports, memorials, and recommendations as may advance the cause of agriculture, and promote and diffuse agricultural knowledge; to examine, and when necessary, report upon the practicability of establishing agricultural schools, colleges, and model farms; to set forth the advantages of agricultural and geological surveys, and show the importance of the application of science to agriculture; to represent through their reports the relation of our agriculture to that of foreign countries, and to endeavor to

obtain information from such countries; to point out the advantage of introducing any new staples, seeds, and plants; to obtain, so far as practicable, annual statistical returns of the condition of agriculture throughout the different States—all which information shall be published by said Society, and form part of its transactions.

The *Executive Committee* shall transact the general business of the Society. It shall consist of five persons, who shall designate the time and place for exhibitions, regulate the expenditures, and take such supervisory charge of the business of the Society as may best promote its interests. This body shall elect its own chairman. Three members shall constitute a quorum.

The *Treasurer* shall keep an account of all moneys, and shall pay bills only after they have been audited by the Corresponding and Recording Secretaries, and a member of the Executive Committee, and countersigned by the President of the Society or the Chairman of the Executive Committee.

Corresponding Secretary.—The duty of this officer shall be to correspond with persons interested in agriculture; at each stated meeting he shall read such portions of his correspondence as may be of general interest; and it shall be his duty to carry out and advocate the views of the Board of Agriculture, in obtaining, arranging, and publishing any information they may desire to have laid before the agricultural community.

The *Recording Secretary* shall keep a record of the minutes of the Society, and of its Executive Committee.

Sec. 4. The annual meetings of this Society shall be held at the city of Washington, on the first Wednesday of February in each year, when all the officers of the Society for the ensuing year shall be elected by ballot. The Executive Committee, however, shall be competent, with the approbation of the Society, to appoint occasional meetings, to be held at other points. Fifteen members shall constitute a quorum for business.

Sec. 5. This Constitution may be altered at any annual meeting, by a vote of two-thirds of the members in attendance, provided not less than fifty be present.

The question of applying to Congress to establish a Bureau, or Department of Agriculture, was ably discussed in convention; but the friends of governmental aid in that direction unfortunately divided among themselves—some insisting that the great farming interest demands a cabinet minister far more than either the army, navy, or post office department; while others would go no further than Presidents TAYLOR and FILLMORE had recommended—*i. e.*, create a clerkship under the Secretary of the Interior, to be called an Agricultural Bureau. Both schemes were opposed by Gov. STEELE, of New Hampshire; Senator DOUGLAS, of Illinois; ROBINSON, of Indiana; THOMPSON, of Mississippi; and many others. The following resolution, offered by Mr. JOHN A. KING, of New York, was finally adopted:

Resolved, That this Convention respectfully request Congress to take action upon the subject of agriculture, and afford such efficient aid as in their wisdom shall be best calculated to advance the great interests of that branch of industry.

This resolution, insisting on the duty of Congress to do something that shall “afford efficient aid to agriculture,” passed *unanimously*—leaving it to the wisdom of the law-making power to determine the way in which such assistance shall be rendered.

So soon as all State, County, and other agricultural societies, *unite their strength*, they will command both Congress and State Legislatures, in a way not to be resisted, to do all that ought to be done in behalf of the agricultural interest, which pays three-fourths of all National and State taxes. It is only by a wise co-operation that the friends of agriculture can do anything against the leaden rule of General Apathy. Let the 300 associations for the advancement of agriculture confederate under a federal head, having a National Board of Agriculture, as provided in the Constitution, and their success will be alike certain and brilliant. This will be a glorious achievement, and one worthy of a nation of farmers who own the soil which they cultivate. To say that one or two hundred thousand farmers in this free and happy country can not act harmoniously together to promote the honor and increase the profits of their noble calling, is to assail both their patriotism and their self-respect. Agriculturists love their profession, and are ready to combine their individual efforts to elevate it, until there shall be at least as many farmers in Congress as lawyers. Why not? The youth in every rural district in the United States greatly need good text-books on agricultural physiology,

chemistry, geology, botany, engineering, the study of soils, and other departments of agricultural science, which they never will get unless something more than mere talk is done for agricultural education. The time for action has arrived; and all State Societies and Boards of Agriculture should appoint at once the three members in each State, Territory, and the District of Columbia, who are to form the United States Board of Agriculture. Such a Board will carry out the idea of the illustrious farmer of Mount Vernon.

With the aid of Congress, which this Board can not fail to receive, the National Society will be able to give every member more than an equivalent for his two dollars yearly subscription to its funds. The Journal of the Society, and its facilities for obtaining and distributing valuable seeds, are advantages and objects of great importance. It has not merely a continent for the theatre of its operations, but the whole vegetable and animal kingdoms of the globe to select from. Government ships and officers, that visit all seas and lands, are at the service of the United States Agricultural Society; and this Society is no more than the servant of all local societies that see fit to avail themselves of its labors, either at home or abroad. Foreign ministers, charges, and consuls in other nations, the heads of departments, and members of Congress, will all render valuable aid, if properly approached. Let us prudently adapt ourselves to the circumstances with which we are surrounded, and use the means so clearly within our reach, to place the arts, the sciences, and the literature of rural affairs in this country, in advance of those of any other in the world.

SOURCE OF THE NUTRITIOUS PROPERTY OF VEGETATION.

The nourishing property of wheat, corn, and other grains, is owing to the gluten contained in them; and this gluten consists, in great part, of nitrogen. It is of course an important object with the farmer, to increase the proportion of gluten, and that is done by supplying additional nitrogen in the aliment of the plant. Carbonic acid and water are the chief sources of *growth*. Nitrogen is the principal element constituting the nutritive quality. The atmosphere contains a large quantity of nitrogen. It is not supposed to be taken up by vegetables, however, from the atmosphere, in its simple form, but, by combination with hydrogen, in the form of ammonia. By the digestion of the ammonia, the nitrogen is afterward separated in the plant and used to constitute the peculiar product, gluten, to which its nutrition is owing.

Ammonia is produced by the decay of most animal substances. In this way it is that the application of manures is so beneficial to plants;—by the supply of ammonia furnished, which being digested in the plant, results in a separation of nitrogen, which enters in the tissues of plants and produces their nutritive quality.

Ammonia is readily absorbed by water, and the rain and dew become impregnated with it, and it is thus administered to vegetables in small quantities. This may be sufficient for their existence and ordinary growth; but a greater supply of ammonia is necessary to some plants, on account of their peculiar economy. This is the case with all plants containing much gluten. And this substance may be greatly increased by a liberal supply of manures from which ammonia is more abundantly provided. These plants can therefore only be cultivated advantageously by a free application of manure, or otherwise an equivalent provision of ammonia in another form. Corn ordinarily, when raised in vegetable mold, contains nine and a half per cent. of gluten; but raised on land manured with blood or urine, has been found to contain thirty-five hundredths of gluten.

Gypsum has the quality of absorbing ammonia from the atmosphere, and yielding it again to water which may soak through it. This is the mode in which gypsum has a beneficial action on vegetation, while the gypsum itself held in solution in water is considered to be injurious. — *New Eng. Farmer.*

A knowledge of the source of the nutritious properties of vegetables, can not fail to be interesting and valuable to every farmer. The above article is well calculated to throw light on the subject, which, though so very important, is but dimly understood. We must, however, differ with our contemporaries in one respect. That the nutritious value of wheat, corn, oats, &c., is in proportion to the gluten or other nitrogenous substances they contain, we believe; and it is so natural to suppose that “by supplying

additional nitrogen in the aliment of the plant we should increase the *proportion of gluten* in the grain," that most people, and indeed many able chemists, have adopted the belief without sufficient evidence of its correctness. We know that wheat is greatly increased in quantity per acre by the application of ammonia in any available form—that in fact ammonia is the one special ingredient which a manure for wheat should contain. This being the case, it is not to be expected that wheat and corn, "proverbially characterized as yielding starchy seeds, and whose predominant peculiarity is to produce carbonaceous substances, would in their most perfect state of development be rich in starch rather than in gluten and other nitrogenous compounds." Mr. LAWES, who has perhaps experimented more on the requirements and composition of the wheat plant than any other living investigator, says on this point:

"My experiments do not give the slightest indication of an increase of nitrogenous element of wheat grain by the employment of ammoniacal manures. That the average produce of nitrogen in the crop bears a certain relation to the ammonia supplied in the manure, is very evident; but the per centage of nitrogen in the grain can not be increased by means of it. In some experiments, the quantity of ammonia supplied by the manures was from 60 to 70 lbs. per acre, and in some instances more; but the analyses give no evidence of an increased per centage of nitrogen by its supply, and the highest amount obtained in the series was from an experimental plot where no ammonia was supplied in the manure."

It is very evident that we should be very careful in coming to hasty conclusions on the requirements of plants, and the influence certain kinds of manure would have upon them, from a simple knowledge of the chemical composition of the seeds, &c., irrespective of their peculiar characteristics, and without due regard to vegetable physiology.

It is, too, not true that the greater amount of gluten or nitrogenous substance the plant contains, the more nitrogen will it be necessary to supply in the manure: for, of the leguminous plants, the clover seed contains 7 per cent. of nitrogen, and that of peas, beans, and tares, 5 per cent., while wheat contains on an average but 2 per cent. of nitrogen in dry matter; yet it is most clearly proved that wheat requires much more nitrogen for its production than either clover seed, peas, beans, or tares. The recent experiments of Messrs. WAY and THOMPSON, on the "absorptive powers of soils," throw a ray of light on this interesting subject, which will probably lead to more important elucidations. These gentlemen found, by a series of experiments, that the absorptive power of soil was owing to the double silicate of alumina and soda which it contained—that when sulphate or any other *soluble* salt of ammonia was added to the soil, a decomposition took place, the ammonia uniting with the silicic acid in the place of the soda, which unites with the sulphuric acid and is washed out, while the double silicate of alumina and ammonia is left in a nearly insoluble condition. We quote from Prof. WAY's lecture:

"But in order that they might fully understand this part of the subject, he must explain to them an idea which he had taken in reference to this double silicate of ammonia and alumina. He had already stated that water did not dissolve the whole salt, but that the silicate of alumina remained undissolved, while the silicate of ammonia was dissolved in small quantity. Now he had found that this solution of silicate of ammonia, when carefully evaporated, dried up on the sides of the dish into thin transparent scales, like very thin glass, and these scales were found upon examination to be silica; the ammonia having evaporated with the water, and leaving the silica as a transparent varnish on the dish. Was it not likely that this fact formed the true explanation of the manner in which silica was deposited on the straw of wheat? He thought it might be. Chemists had always had a difficulty in accounting for this deposition of silica on the straw of cereal plants by reference to the soluble silicates of potash and soda; and the solubility of silica in ammonia had not been before observed. By the easiest and simplest process a weak solution of silicate of ammonia, in passing through the plant, might leave its silica behind; and the probability of this explanation was increased by Mr. LAWES' observation of the loss of ammonia from the soil in the growth of corn crops. Mr. LAWES had found that for every pound of ammonia of which the nitrogen was fixed in the wheat, in the shape of aluminous constituents, other four pounds were lost to the soil in the growth of the crop—that is to say, that five pounds of ammonia were required to produce a quantity of wheat containing nitrogen equal to one pound of ammonia. This loss would at once be accounted for, and would inevitably result, if the deposition of the silica were due to the action to which he had referred."

Thus it would appear that instead of plants which contain the largest amount of nitrogen requiring the largest quantities of ammonia or nitrogen in the manure, it is more probable that plants require ammonia in proportion to the amount of silica they contain; so that nearly all the grasses—wheat, corn, oats, barley, &c.—would require much more nitrogen for their perfect development than the leguminose—clover, beans, peas, &c.,—which, compared with the cereals, contain but little silica. And this conclusion is sustained not only by direct experiment, but by the successful practice of the best farmers in this country and Europe—clover, peas, beans, &c., being considered the best possible preparative for the wheat crop—better, in many cases, than the summer fallow; while the succession of cereals always, unless the soil is kept up by manure, produces exhaustion.

ENGLISH AND AMERICAN PLOWING.

In the cultivation of the soil, the first and most important operation is its thorough pulverization, loosening the soil to enable the roots of plants to penetrate and perform their functions, and admitting the atmospheric air, the presence of which is not only beneficial in disintegrating the minerals of the soil, but absolutely necessary to render all the food of plants fit for assimilation. The spade is perhaps the best and simplest implement to accomplish this object, but in extensive farming operations the slowness and expense of the process are sufficient to warrant the opinion that it will never, as has been thought by some, be generally adopted.

The plow is necessarily a much more complex implement, inasmuch as the labor of the horse is substituted for that of man. When we look at the rude and simple wooden plows with only one handle to guide them, which were used very generally a century ago, and which are in fact now used in the Hebrides and other countries in the old world, and compare them with one of our American plows, so neatly made and beautifully finished that it would be an ornament to a gentleman's drawing-room, we have room for a little gratulation, and are apt to imagine that now we have arrived at perfection in the art of plowing. Yet even now much difference of opinion exists as to what good plowing really is—some liking wide, flat furrows, and others narrow, lapped ones; and it is this disagreement of opinion that constitutes the difference of plowing in Great Britain and America.

The best Scotch and English farmers consider that the *depth* and *width* of furrow should bear a constant proportion—that the furrow should be rectilinear—and that, when raised, the exposed surfaces should be of equal breadth on either side the furrow. Any departure from this rule is considered a positive fault; and in deciding on the merits of different plowing, this is made one of the standard criteria. The most approved plowing in Scotland is a furrow seven inches deep by ten wide, with a lap of three inches, thus leaving seven inches on each side of the furrow. A furrow of this proportion is considered to be easier turned than any other, while more soil is exposed to the meliorating influence of the atmosphere; and when dragged down, the weeds and grass, or clover, &c., are better covered and rotted, while a much deeper and better bed of loose soil is prepared for the seed.

Theoretically, this is doubtless the best mode of plowing, and the nearer we approximate to it in practice, the better. American farmers, however, are not content to walk from one end of a field to the other, and only turn over nine or ten inches of sod; fourteen to twenty inches suit their go-a-head views much better. And so it is that we usually plow furrows which in Scotland or England a farmer would not allow us to turn if we would plow the land for nothing;—at least, so we have often been told by good English and Scotch plowmen. There is a reason for this: the comparatively cold

and sluggish climate of Scotland has not that decomposing and meliorating effect on the recently plowed soil as has the intensely cold and hot weather of America; and so it is that we can turn over for our summer-fallows furrows which in Great Britain would never be got to pieces in one twelve-month, whereas here they decompose and fall all to pieces when cross plowed, though there is often but six weeks between the first and second plowing. Nothing surprises old country farmers more than this. We have heard good English farmers say, after they had been in the country a short time, "I never would have believed that such great wide furrows would tumble to pieces so readily in such a short time." This is undoubtedly the case; and, indeed, if it were not so, such is the shortness of the plowing season in the northwestern and eastern States, we should find it very difficult, much more so even than at present, to get our land ready for the seed.

Yet, while we admit this, we would not argue in favor of wide furrows, unless a corresponding depth be observed. Thus, if we plow a furrow fourteen inches wide, it will be necessary to go ten inches deep, with a lap of four inches, to get the maximum of surface exposed to the atmosphere, and have the sides of the upturned furrow at an angle of 45 degrees from the bottom surface. In plowing clover ley for wheat immediately before sowing, as is generally done in Great Britain, we think the Scotch mode superior to any other. We should, however, like to hear our correspondents' views on this subject; for, as plowing lies at the foundation of all good farming, it is certainly important that as much light as possible should be thrown on the subject, and that it be done in the most scientific, economical, and expeditious manner possible.

In plowing a clover sod but once for wheat, after grazing it in summer or taking off a crop of hay, the great difficulty is in destroying the grass and weeds. We have now in our eye a field that was well manured and plowed in this way last fall, just previous to sowing. It looked exceedingly well the fore part of winter and in early spring; but the grass grew so thick and strong that the wheat was much injured, and turned out a light crop. In Norfolk,—which, though naturally one of the poorest sands, is cultivated better and yields heavier crops than any other county in England,—they use an iron roller about two and a half feet in diameter, and about two inches wide at the circumference, which is drawn between every furrow after it is turned over. It is drawn by one horse, which walks after the plow in the furrow, while the roller passes on the juncture of the two last turned furrows, pressing every bit of grass, weeds, &c., completely out of sight; so that when the land is dragged, it is some five or six inches below the surface. It does only one furrow at a time; so that it is almost as expensive as plowing, taking a horse and boy to do as much as a team will plow. Yet we believe it pays well, and is one of the cheapest and most effectual means of destroying grass and weeds in wheat. Those who have never seen it used can hardly imagine the benefit which attends its adoption.

FLAX—CULTURE AND FLAX COTTON.

THERE can be no doubt that the soil and climate of a greater part of the United States are well adapted to the growth of flax of good quality and quantity, and that we shall soon be extensive exporters instead of as now importers in linen and flax to the amount of nearly nine millions of dollars per annum.

The Chevalier CLAUSSEN process of preparing flax cotton is doubtless one of great value, and patent rights have been sold we believe for most of the eastern and western States, so that farmers who raise flax will be able to sell it to the manufacturer in the raw state, and realize much higher profits than when they had to incur the expense and labor of preparing the flax themselves.

It has hitherto been the practice with many flax-growers to raise it only for the seed, taking no account of the fibre, which is in reality the most valuable part, and it was thought incompatible to grow good flax and seed. This, however, we believe is a mistake; good seed and good flax have been often raised together, and will be much more generally when the value of flax is better understood. In pulling flax, it is not easy to seize upon the proper time, so as to make sure of good flax and seed. If pulled *too early*, much seed is lost; and if it be delayed only a short time *too long*, the quality of the fibre is greatly deteriorated. The seed must give way to the fibre. It is recommended to let the flax be fully out of flower, the seed balls well formed or set, and seed turning brown, and the flax stalks yellow beneath though green at the top; it is then in the best stage for pulling with most profit to the grower. The pulling should now be carried on as rapidly as possible. It is done by the puller taking hold of a small quantity near the top as it stands, and carefully pulling it up, keeping the root ends even. It is then tied into sheaves or bundles, and set up in the field like wheat. Rippling is the next process, and is done by a machine containing a row of upright teeth so adjusted as to take off the seed, leaving the fibre uninjured. The Flax Improvement Society of Ireland says that the rippling should take place simultaneously with the pulling—that the flax should not remain in the field the second day, but be rippled immediately and taken to the steeping place before it hardens.

At the annual meeting of the Tippecanoe County (Indiana) Agricultural Society, the principal subject of discussion was the culture of flax, when the Hon. H. L. ELLSWORTH, late Commissioner of Patents, stated that—

“A committee had been sent from Philadelphia to France, Holland, England, and Prussia, for the purpose of examining the modes of cultivation, best soil, etc., and that the committee had reported highly favorable as to the adaptation of our soil and climate for raising this important product. The company who sent this mission abroad possessed a heavy capital, which they have invested in the manufacture of the article. They offered to make a contract with him for \$100,000 worth, and they offered for flax delivered in Philadelphia, equal to Russian, \$250 per ton. Mr. E. stated that he had sent by mail for a sample of the quality, and intended to enter into the arrangement provided a similar kind could be raised upon the prairie lands. He had selected seven or eight different kinds of land, upon which he had sowed different kinds of seed, from one to two bushels to the acre, to test the yield of seed and lint. At the price named, the lint would be worth \$40 per acre. There was a machine coming from Springfield for dressing flax. A man and boy with it work out one and a half tons of stems a day. There can be 14 bushels of seed raised to the acre. This will yield nett \$6. He had no question but that flax was the best article to cultivate in this country, as a greater value could be got into a smaller compass than any other product our soil and climate could raise. If the oil should be manufactured here, the cake would furnish superior fattening food for cattle. It is now sold to export for that purpose.

“The flax cotton in its second process of preparation has a very strong resemblance to cotton, and is superior in many respects. It has a longer staple. The lint is hollow, cellular, like the human hair. In the chemical agencies employed to prepare it, soda is used to fill these cells. Then an application of a weak solution of sulphuric acid causes a contraction which blows it up. The hypochloride of magnesia is then used to finish it for spinning. Flax cotton thus prepared contains a felting quality, which cotton does not. While alkalis destroy high coloring in cotton, it does not in flax cotton. The latter can be made a very high color. If one-half is mixed with silk, it is almost impossible to tell it from pure silk. It makes fine bagging in a common cotton machine. A mowing machine will cut the crop. A yield of 10 bushels seed and 400 lbs. lint can be safely calculated to the acre. It can also be mixed with wool for winter clothing. Flax cotton bids fair to be an article of great export. Mr. E. had offered to raise 1000 acres for the Philadelphia company, if the quality would answer. He expected to see flax cotton sent from here the same as cotton from the south.”

—•••—

TO REDUCE SOLID FEET TO BUSHELS.—Multiply the number of solid feet by 45 and divide the product by 56; the quotient will be the number of bushels.

Reason.—As one bushel contains $2150\frac{2}{3}$ inches, one solid foot is $\frac{4}{5}\frac{2}{3}$ of a bushel.

Example.—How many bushels in a crib or box 8 ft. long, 4 ft. wide, and 2 ft. deep? $8 \times 4 \times 2 = 64$, which multiplied by 45 and the product divided by 56, gives $51\frac{3}{7}$; the number of bushels which the box contains. M. K.—*Bentonville, Ind.*

THICK AND THIN SOWING.

THE proper quantity of seed to sow per acre is a matter of much importance in agriculture, and consequently much difference of opinion exists on the subject. In Great Britain the point of thick and thin sowing has perhaps been more discussed than with us; and after so much investigation, each system has its strenuous and perfectly satisfied advocates. Before the days of DAVIS, MECCHI, HUXTABLE, and other new lights, the amount of seed sown in England was generally, of wheat, three bushels; barley, three and a half; and oats, four. These gentlemen, however, showed that by under-draining, subsoiling, and *high manuring*, a large crop of wheat might be obtained from *one peck* of seed per acre. This was considered a wonderful result, and the number of bushels of wheat that would be saved to the country by the adoption of their sowing system was calculated, and a great parade made of the result. But while it was true that a good crop could be obtained from a peck of seed per acre, if it all grew and did well, it was found that in a certain number of acres there was invariably some that did not do well, from the seed not germinating, winter-killing, &c., and that the loss sustained by such failures more than counter-balanced the profit by saving seed; and the conclusion arrived at was, that it is necessary to sow much thicker than the actual requirements of the plants demand, on purpose to insure a good crop in all cases; so that, as is usually the case, the "happy medium" is generally adopted, and two bushels of wheat per acre would be about the average quantity of seed sown in Great Britain. It is generally considered that from a peck to a half bushel less seed is required when drilled in, than when sown broadcast. In Canada, especially in the lower Province, much more seed is sown per acre, of wheat, barley, and oats, than with us; and indeed we have often thought our farmers are much too sparing of seed, especially of oats and barley. When wheat is drilled in, we consider that one and a half bushels per acre are sufficient if the soil is rich and the seed well put in; but when sown broadcast, we should always prefer two bushels, and in many instances two and a half bushels would be none too much. A less quantity of seed would often produce as good a crop, but we consider it best not to run the risk of losing half, or even a part of the crop, for the sake of an extra peck or two of seed per acre.

Some difference of opinion exists among farmers, as to whether rich or poor soils require the most seed. It is argued on the one hand, that if the soil is very fertile, the plant will grow much stronger and branch out considerably; and if there is too much seed sown, the plants will still branch out, and being too thick on the ground they will grow up fine, and the crop will be laid. Others say that if the soil is poor, or destitute of a sufficient amount of fertilizing matter, it is certainly bad policy to increase the number of plants to consume it—that a much wiser plan would be to have fewer plants, and let each of these have sufficient food and be perfectly developed, and not have a large number, none of which can be properly matured from lack of the necessary ingredients. This appears good reasoning, and is perhaps correct in the case assumed; but it is not the true point at issue. If the soil does not contain sufficient ingredients for a crop of wheat, it should not be sown at all; for it is very doubtful if, in such a case, the plants would thrive and do well, even though they were planted so far apart as to give them the required amount of ingredients in the soil.

The point to decide is, whether a soil that will produce a crop of wheat of twenty or twenty-five bushels per acre, requires more or less seed than one that will produce thirty-five or forty bushels per acre. In such a case, we decidedly think that the rich land would require the least seed, for the reason that it would grow so much stronger and bushier than on the comparatively poor soil.

We make these remarks this month, in the hope that some of our practical correspondents will favor us with their views and *experience*, in time for the next number.

Condensed Correspondence.

LARGE HOG.—I slaughtered, on the 9th of March, a hog *fifteen months old*, that weighed 530 lbs. DANIEL DAWSON.—*Beaver Co., Pa.*

WEIGHT OF MERINO LAMBS.—I have some good sized lambs; one of them at nine days old weighed 17½ lbs., and is now (May 29,) two months old and weighs just 50 lbs. They are of the French Merino breed. ISAAC M. GILLET.—*Clyde, Wayne Co., N. Y.*

SPANISH MERINO SHEEP—GOOD SHEARING.—I have a flock of 46 sheep, from which I cut 288 lbs. of good, clean washed wool, which is an average of 6¼ lbs. per fleece. Of these 46 sheep there are 29 ewes, all of which had lambs this spring; 9 yearling ewes; 7 yearling bucks; and 1 three years old buck, which cut 12½ lbs. washed wool. Who can beat this in Genesee county. H. N. WRIGHT. *Alexander, N. Y.*

TO REMOVE GARLIC TASTE IN BUTTER.—A friend of mine who keeps a butter dairy says, to destroy the taste of garlic in the butter, when cows are pasturing where garlic grows, put into the pail as much pulverized saltpetre as will lay on a half-dime piece. Put it in before milking, each time the pail is emptied. He says the butter will not taste of garlic in the least. JACOB HOWELL.—*German-town, Pa.*

DROPPED MANURE.—I see in your paper many articles respecting agricultural economy, that are interesting to the practical farmer. I thought I would add a little to its columns, if you think this worthy of a place therein. All manure that is dropped by cattle in fall and early winter in meadows, &c., should be beaten as soon as ripe for that purpose, or when it becomes thawed in winter by the warm days and rains. Beat it to pieces finely, so that the strength may soak into the ground by the next rain or thaw that may come; this will prevent its drying up. If it is let alone until spring, and then beaten, it will dry up and lose its value in a great degree. J. PORTER.—*Scituate, R. I.*

PLASTER ON WHEAT IN THE FALL.—As many farmers in this vicinity are putting plaster on their wheat in the fall instead of the spring, as heretofore, I have taken pains to inquire the reason of the change; and believing the information obtained important to wheat-growers generally, I take this method of giving it to the million, if you think proper to place it in your widely circulated journal.

Wheat, when plastered in the fall, obtains more root, and is thus enabled to stand the frosts better: it has the assistance of the plaster at a season of the year when it is almost impossible to go over the fields, and when it is most needed—namely, the very early spring: it gets its growth and ripens in good time; whereas, when applied in the spring, the wheat continues to grow late, sometimes to the injury of the crop—a superabundance of straw, falling down, rust, &c., &c., oftentimes being the consequence. A SUBSCRIBER.—*Niagara Co., N. Y.*

GAPES IN CHICKENS.—I noticed in your June number an article on *Gapes in Chickens*—cause, cure, &c. Being a subscriber to your valuable paper, I thought I would give my views and experience on the same subject. The writer stated the cause of gapes in chickens to be exposure to cold, also giving what I do suppose to be a most excellent cure. In the first place I would observe the old adage—"An ounce of prevention is better than a pound of cure." I fully admit that cold, wet weather, and exposure to cold, are fruitful causes of gapes in young chickens, though in my opinion not the greatest cause. The cause that mainly produces gapes in young chickens, is unnatural food. By noticing the habits of animals in a state of nature, we learn how best to treat them when domesticated. This I give as a general rule, as I have never seen the fowls alluded to in a state of nature. Fowls of all kinds, when not domesticated, do not hatch their young until their proper food can be obtained; (worms, bugs, and insects are the natural food for chickens;) hence the importance of giving some food of a similar character.

I will now, as briefly as possible, state how to prevent the gapes. First, spread some wood ashes

on the ground, where water will not lay or run on, and thereon place your coop, made close on top and all around except the south side, which should be open to admit the sun and to allow the chickens to go out and in. Also have the coop so arranged that the hen can not get where you place the food for the chickens after they are two days old. Feed no raw corn-meal dough, as is the common practice, but give a sufficient quantity of baked bread without salt, made of either corn or wheat meal, and at least one feed a day of curd made of sour milk, and every two or three days give some fresh meat—beef, veal, mutton, &c.—either raw or cooked, chopped up fine, and mixed with the curd; and as soon as the chickens are old enough to eat grain, give some wheat and small corn, (the hen can be fed principally on grain,) and a supply of water will insure your chickens from the gapes. CHESTER COUNTY.

IMPROVERISING THE SOIL.—I have been particularly interested in reading the editorial remarks on the subject of the exhausting system of cultivation practiced by too many of the farmers of our country, and have wondered that the appeals to the reason, the interest, and the credit of their brethren, so often and so ably made by the editors of the *Farmer*, did not more frequently elicit a response from some of the thousands of your readers, who can not but be sensible of the importance of the subject; and though I am sensible that the space might be occupied by the production of an abler pen, yet, as few seem disposed to devote their time and talents to the subject, (if we may judge from the contributions to your columns,) I have concluded to offer a few remarks, which you are at liberty to dispose of as may seem to you best.

It is natural to suppose that a large proportion of the inhabitants of our country will, for the facilities of commerce, manufactures, &c., congregate in cities and villages, and a consequent demand will be made upon the farmer for the means of sustaining life and for the raw material for manufacturing, which are produced from, and consequently exhaust, the soil of its elements, particularly such as enter sparingly into its composition. These are circumstances over which we have no control, nor would we wish, were it in our power, to reverse them; the farmer is under the necessity of exchanging the products of the soil for those of the labor of the mechanic and manufacturer, though it may be at the expense and ultimate exhaustion of certain essential elements of his food and clothing. These are natural results, and Nature, ever right, is as uniformly kind; for although she has not furnished in inexhaustible quantities every essential element to every soil, yet she has placed all within our reach, though not always in such quantities, nor so easy of access, as to render us justifiable in wasting such as are already in our possession.

Now, to supply this necessary demand of the inhabitants of cities and villages, and at the same time preserve the primitive fertility of the soil, it appears to me quite necessary that we ascertain, first, what are the elements of our cultivated crops; second, which, if any, of those elements are deficient in our soil; and thirdly, whether the manure furnished by our animals contains the deficient materials in sufficient quantities. As to the first, we find that carbon, oxygen, and hydrogen greatly predominate in all vegetables, besides which the common earths, silica, alumina, and lime, enter into the composition of different plants in variable proportions, as also do soda, potash, and sulphuric, phosphoric, and some other acids, besides nitrogen, chlorine, and some other substances. Secondly, few soils are deficient in carbon; and if they are, the atmosphere is the great reservoir, from which perhaps vegetables absorb through their leaves all that is requisite, in the form of carbonic acid gas. The necessary quantity of oxygen and hydrogen is furnished from water. Silica and alumina are inexhaustible elements of almost every soil, whereas lime is deficient in some; but an abundant supply is found within a reasonable distance of every section of our country. Potash is rather an abundant material in most soils, but it enters so largely into the composition of most plants, that it is by no means inexhaustible; and if by a waste of the materials that furnish this indispensable the quantity should become deficient, we shall find that an artificial application will be made at an expense that will greatly diminish the profits of our business. Soda and chlorine may, if deficient, be furnished by an application of common salt, and sulphuric acid by that of plaster. But there is an element of the staff of life, a component part of corn and wheat, the substance of which our bones are mainly composed—to wit, the phosphate of lime—which, important as it is, is furnished naturally in the soil in quantities by no means inexhaustible; and until recently no important depositions of this mineral have been known to exist in our country; but, thanks to the scientific exploration of Prof. EMMONS, phosphate of lime has been found in large quantities somewhere near lake Champlain, how easy of access I know not, but with our present and increasing facilities for transportation, no doubt but the discovery is a great acquisition to the means of renovating our worn out lands. Nitro-

gen, which is an important element of some of our most important crops, is furnished from ammonia, which being very volatile, is disengaged from all putrifying animal and some vegetable substances, and having a strong affinity for water, is absorbed and returned to the earth by falling rain.

Thus it seems nature has provided means for replenishing the soil with the substances that growing crops are constantly drawing from it, either by her own process or by placing them within our reach; but the natural process is too slow for us of this railroad age, and that of purchasing and transporting them from a distance is what few will resort to as long as they can raise half a crop. It is true our farms may be kept up to their natural state of fertility by a judicious application of all the manure that could be made from the crops that are grown upon them; this is self-evident; and it is just as evident, that if the farmer sends to market two-thirds of the grain that he grows, and though he keeps stock enough to consume all the grass, hay, vegetables, and some grain, and disposes of the product of these in the form of beef, pork, wool, butter, &c., he is exhausting his soil of the elements of those articles, the production of which alone gives his farm its value.

A further and more censurable cause of the deterioration of the soil, consists in the waste of the fertilizers within our grasp—the manure of our own stock. How many farmers throw down the bars of their farm-yards, (for such seldom have gates,) and suffer their cattle to stroll at their leisure upon the highway, or along the lane that leads to their watering place, perhaps standing a great part of the day on the leeward side of a fence or hill that affords a better shelter than the bleak and dreary yard, purposely located on a hill so that the nasty leachings may run off, perhaps in the road or brook, and the yard be nice and dry. How many suffer their swine to run at large upon the highway what time they are not in some neighbor's cornfield or orchard. And thus, for six months in the year, what might be accumulating to fertilize the soil is scattered along the highway, to annoy and bedaub the feet of their wives and daughters. How many suffer their manure to be in their yards during the summer, exposed to the sun and rains, until by fermentation the ammonia and other volatile parts are wafted by the winds to fertilize other lands, and the soluble parts are either poisoning the water of the springs and brooks, or are enriching the earth far below what will ever be available.

Now, I would ask, how is it possible, under such a system of management, for the soil to retain its primitive fertility? And that this is not an over-wrought picture of the practice of quite too many of the farmers of our country, I think will be readily conceded by every farmer of common observation. But I am well aware that it is easier to find fault than it is to prescribe a remedy, and much easier to propose a remedy than to adopt it. My views with regard to the remedy are perfectly in accordance with those set forth by the editors of the *Farmer*, and perhaps I shall suggest nothing new when I say that, in my opinion, the first step towards a thorough reform should be a general diffusion of scientific information among the agriculturists of our country. The time has gone by when it was generally believed that no other learning was necessary for the farmer, than to read and write, and a sufficient knowledge of arithmetic to compute interest. It is now believed—it is now known by some, at least,—that our profession calls, or should call to its aid, more of the physical sciences than any other profession or business whatever. The earth that we cultivate is a great laboratory, where nature on a grand scale is, by chemical affinities, effecting the decomposition and new combination of the various organic and inorganic materials of which its surface is composed. The structure, position, and elements of the various strata of the earth's surface, have an important bearing upon its productiveness and the facilities for its proper cultivation. Why, then, should not the farmer acquaint himself with the sciences of chemistry and geology? And as his every day business is with nature in her several departments of the animal, vegetable, and mineral kingdoms, those of botany, physiology, and others, would naturally suggest themselves as applicable to his business. But to those who have not the leisure or a desire to acquire much of the knowledge referred to, as well as to those who have, I would say, and say it with emphasis, *husband the means that are within your reach; keep as much stock as is consistent with your interest.* Perhaps our markets are as well supplied with meats, butter, &c., as is profitable to the consumer or to the interest of the producer, at their present relative prices. If so, it should not be increased. But the quantity and quality of the manure may be vastly improved and increased by confining every animal to properly prescribed limits—by keeping the manure from the influences of the sun and rain—by preventing the waste of the liquid part, and strewing it frequently with plaster, or other substances calculated to fix and retain the gases. Swamp muck would answer a two-fold purpose by retaining the gases and augmenting the quantity. S. H.—*Plattekill, N. Y.*

FRENCH MERINO SHEEP.

BY GEO. CAMPBELL, OF WEST WESTMINSTER, VT.

I RECEIVED your communication, and was very glad to hear you express the determination not to publish anything unless on examination you thought it to be for the interests of your subscribers. I am of your mind, that the "agricultural papers have been too much used to advance the interests of speculators;" and I also agree with you that publishers should be more cautious, and not publish articles until they are satisfied that they contain nothing but *truth*. Anything I say in relation to the subject will not intentionally be misrepresented.

I send you a wood cut, engraved from a Daguerreotype, of a group of French sheep imported by WM. CHAMBERLAIN, Esq., of Red Hook, of your State, and myself, one year since.

The buck "Matchless," represented in the accompanying cut, is three years old, and weighed on the first of last March, 261 lbs. His fleece of one year's growth was 20 lbs. 12 oz., after losing a portion of it on the sea voyage. As to the shape, constitution, thickness and fineness of wool, this buck is considered by all who have examined him to be equal to any of the breed. He was my first choice in France, and was very much admired there, especially by some gentlemen from Australia, who owned large flocks of sheep, and were in France for the purpose of buying bucks to cross with their sheep, which originated in Germany. One of these gentlemen informed me that his number already reached 44,000, and that he intended to increase it until it reached 100,000. This man alone wanted 100 bucks for the service of his own sheep. He also informed me that others from his country were making preparations to travel in France and Spain, for the especial purpose of selecting sheep, with a view to increase the weight of fleece, and if possible to retain the fineness. So you see that not only we "Americans" have the "sheep fever," but that it is rapidly spreading over almost the whole world.

The live weight of the ewes here represented, is about 125 lbs. each. The average live weight of our whole flock of this breed, after having been shorn, did not vary much from 100 lbs. The average weight of fleece of the whole flock, 12 lbs. 8 oz. In selecting the sheep, I regarded a large size as a matter of secondary consideration, choosing those that would produce the most fine wool, according to the cost of keeping.

It is believed by many that the French Merinos require more than ordinary feed and attention, to keep them in good condition; but my experience with them, thus far, leads me to the conclusion that they will thrive well on ordinary keeping. They require nothing but a good pasture during the summer season. I gave mine nothing more. They are well adapted to our climate, and will bear exposure to storms equally as well as any sheep in the country. A portion of ours were turned off to pasture last June, and came to their winter quarters looking remarkably well. They had no grain of any description, nor were they sheltered from a single storm during the season.

Although the French sheep possess many desirable qualities, I should be unwilling to say that they are *greatly* superior to all other breeds in every particular, but believe that all experienced and impartial judges admit that they possess the following desirable points, viz:

1. A good vigorous constitution.
2. That they carry a heavy fleece of wool, of a fair grade; and
3. That they are gentle and docile in their dispositions, with an easy propensity to fatten.

It is my belief that the above qualities are better combined in the French sheep than in any others; but where wool alone is the object, I am of the opinion that there are other varieties of the Merino, of a less size, which will yield as much or more wool, and



GROUP OF FRENCH MERINO SHEEP.

of a finer quality, in proportion to their size, and consequently the cost of keeping, than those under consideration.

There are, perhaps, some few improved flocks of the old Spanish stock, that will compare favorably with the French sheep, for the profitable production of wool; but the variety to which I have more particular reference is the Silesian Merino. I send you a cut of a group of SILESIAN MERINO EWES, which represent them precisely in the same position that they were taken in a daguerreotype view as they were standing in the barn-yard, and can not show all of their good qualities. Still, enough of them are shown so that one may judge of the character of the sheep.

The original stock of these sheep were from the Infantando flock, imported from Spain in 1811 by a Silesian gentleman who was in every way well qualified for a successful sheep-breeder, and who gave his personal attention to the business. They are about a medium size, well formed, and have every appearance of being hardy animals, often attaining a great age. One ewe of this flock lived to be twenty-one years old. The superiority of these sheep is in the excellence of the fleece, which is much finer, thicker, and evener than the common Merinos of this country. The quality will compare well with many Saxon flocks; and as to evenness and thickness of fleece, which holds out remarkably well on their belly and legs, they have no rivals. The length of staple is somewhat shorter than many other Merino sheep, still they produce a heavy fleece. Their wool is white, crimping, and oily, which circulates freely to the outer ends, forming a dark surface, which is not only beneficial to the wool, but partially protects them from the storms.

I am confident these sheep will prove well for farmers living in sections where wool is the greatest object, and who prefer a *heavy and fine fleece* to a light one.

It is the prevailing opinion among wool-growers, that in proportion as the wool grows finer the fleece becomes lighter. But in this point I must differ from them. It has long been my opinion that as much fine wool can be produced from a given amount of keep-

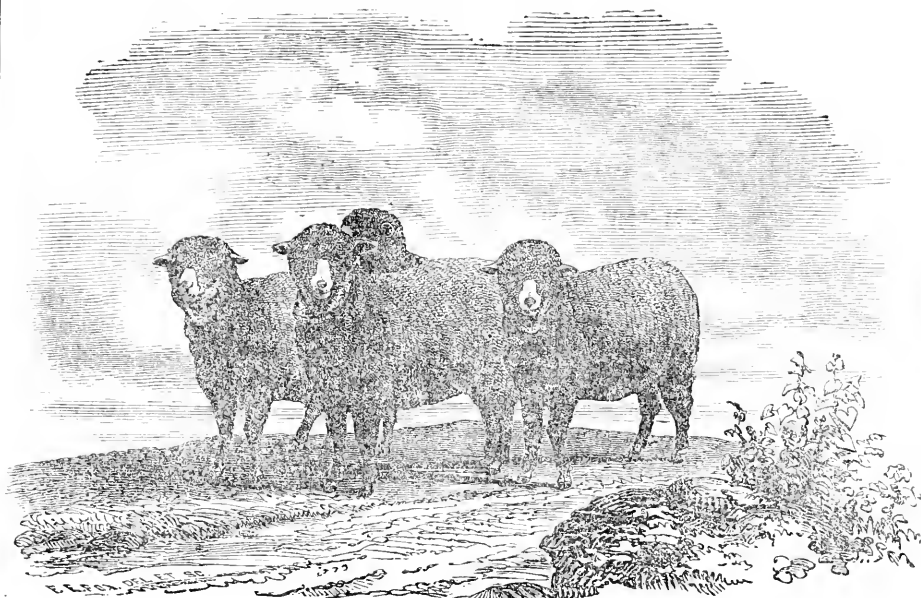

GROUP OF SILESIA MERINO EWES.

ing as that of a coarser grade, and my experience for the last few years has confirmed me in this belief. I am fully satisfied that one hundred or one thousand pounds of fine Merino wool can be grown at a less cost than an equal amount of an inferior quality.

Our Silesian bucks were used by several of my neighbors, and the cross with our common Merino ewes seems to be of a *high* nature. Many of the lambs are wrinkled all over their bodies, and are good sized and well shaped, without any hair or jar upon any part of their bodies, and no doubt will add to the weight as well as to the fineness of fleece. The weight of the ewe's fleeces last year was 7 lbs. 10 oz. unwashed, the growth of 10 months. The present season, in order to more thoroughly test their true value, they were well washed, first by well soaking them, then after letting them stand in the sun an hour or more, taking them into the water under a good spout and washing them until the dark outer ends of the wool became white and the water looked perfectly clear as it ran from the wool. After suckling lambs from January to May, and cleansing in the above manner, the average weight of the whole flock was 4 lbs. 5½ oz. Our bucks of this breed have not been sheared this year, but last year their fleeces weighed from 7½ to 10½ lbs. of ten months growth only.

There is of late considerable attention given to the subject of wool-growing, and I hope to hear from others engaged in the business through the pages of the *Farmer*. If farmers can be convinced that they can grow fine, soft wool as cheap as that of a coarse, harsh quality, they will surely enter into the business with a good deal of interest.

♦♦♦

CUTTING OATS.—Some of our contemporaries have been recommending farmers to cut their oats when quite green, stating that the straw is much better for fodder, and that the grain fills and yields quite as well as though left till quite ripe. We do not know but this is true to some extent, but are inclined to think that oats are the worst of all our grain crops to cut early, and we prefer to let them get so ripe that a few of the first formed grains will shell out, obtaining in this way a much heavier and fully matured grain.

Horticultural Department.

CONDUCTED BY P. BARRY.

NOTES ON STRAWBERRIES.

For the benefit of those of the readers of the *Farmer* who are desirous of information on fruits, we jot down, while fresh on the mind, the results of another year's experience.

First among the fruits of the season comes the *strawberry*. The culture of this fruit is every year attracting more attention; around Rochester it is assuming considerable importance; several large market plantations are already pouring in their abundance. The prospect is that Rochester will be soon, if it be not already, the best supplied town in the United States with this delicious fruit. We are quite confident that *now*, in point of quality, the strawberries of the Rochester markets compare favorably with those of other places; but there is yet great room for improvement. Our growers generally take good care of their plantations the first or second year, and produce splendid crops; but the third, and after, the beds get old, the ground all covered, and the fruit runs down to the miserable *market* size. But purchasers are learning to buy and eat, as we learn to cultivate; they are becoming more difficult to please and more discriminating in their prices, so that by and by cultivators will discover that it will not pay to be slovenly.

Cincinnati has almost a "world wide" strawberry fame. Her cultivators have penetrated so deeply into its interesting philosophy, that the most learned among the modern Atheuans, with all their pomological wisdom, can not get along without an occasional lecture from them. They have been *pioneers* in the extensive culture of the strawberry, and have promulgated, in the face of stern opposition, some wholesome truths in regard to "stamens and pistils," now very generally carried into practice. But, judging from samples sent this way the present season, and from reports of eye witnesses, their strawberries are far behind those of Rochester, in point of size and beauty at least. We have been looking over the report of the fruit committee on their exhibition of the 3d and 4th of June last, and find that *McAvoy's Superior*, that last year received Mr. Longworth's premium of \$100, has been again awarded the first premium as the best variety exhibited. *Schniecke's Pistillate* is highly spoken of, and many new promising varieties are announced.

The display made by the *Genesee Valley Horticultural Society* on the 25th and 26th of June last, has perhaps never been surpassed, if equalled, in this country. R. G. PARDEE, Esq., of Palmyra, exhibited about forty varieties; several others, from twelve to twenty varieties each. From among these, the fruit committee, consisting of practical cultivators and critical judges, awarded both the first and second premiums to *Burr's New Pine*, "placing flavor and productiveness before size."

This would seem to answer the question, What is the best strawberry grown around Rochester? For several years—indeed, ever since its introduction—the *Burr's New Pine* has been acknowledged to be one of the finest flavored fruits that has been grown or exhibited here. No fruit ever acquired such a popularity in so short a time. But it is worthy of it. The plant is hardy and productive; the fruit large, handsome, and good. The fruit committee of the *Albany and Rensselaer Hort. Society* awarded to it the first premium both last year and this. The report this year reads thus:

"For the best and finest flavored variety, to JOEL RATHBONE, for *Burr's New Pine*—beautiful specimens—\$2.

"For the second best and second finest flavored variety, to C. P. WILLIAMS, for *Hovey's Seedling*—very large and beautiful specimens—\$1.

"The committee, in awarding this premium, wish to remark, that notwithstanding they think the flavor of *Burr's New Pine* more delicate and delicious than that of any other variety exhibited, still it is not considered by them as beautiful, as hardy, or as prolific, as the *Hovey's Seedling*, and consequently not so desirable for cultivation on a large scale."

At Rochester the *New Pine* is generally considered more productive than *Hovey's*. We have not seen a crop that would form an exception to this.

The *Large Early Scarlet* is another sort that stands well with the growers here; it never disappoints. Our committee report it "early, productive, and a valuable fertilizer." We have never known it fail to yield a good crop, and it is patient under bad treatment—doing well where others would die out. If we were to be confined to one variety, we should venture to choose this.

Hovey's Seedling is popular here and everywhere, on account of its great size and beauty. In size especially it surpasses all others except the *British Queen*, but it is by no means a great bearer in the gardens of this part of the country, whatever it may be elsewhere. It is more variable in this respect, too, than many others. This season the crop here has not been so good as usual. We went some twenty-five miles almost on purpose to see a bed of this variety from which great things were expected, but we found it a total failure. We saw a large plantation of the most luxuriant plants, rejoicing in the most generous treatment, but not a perfect berry was to be seen. The cultivator is renowned in the art of producing wondrously large strawberries, but this time he made a sad failure. He is said to belong to the "old school," and is therefore an unbeliever in "stamens and pistils"—the necessity of providing a fertilizer. This must be the cause of his failure; and it has probably cured him of his unbelief, for we saw where fresh rows of staminate flowered plants had been not long planted near the *Hoveys*. We think if he had planted his fertilizers at the proper time, he would have had really a model strawberry bed.

The *Boston Pine* (HOVEY'S) is falling in estimation here. It is a prolific, good variety, but needs good soil and first rate cultivation. When the plants grow old, and the ground nearly covered with runners, it is worthless. But it is worth good culture; and its falling off is more the fault of our cultivators than of the plant. It requires to be kept in "hills," free from runners, and in rich soil.

Burr's Rival Hudson is valued here as being very productive, and particularly good for preserving. *Burr's Ohio Mammoth* is a very large and productive variety, light colored like the *New Pine*, but of rather indifferent flavor. *Iowa*—medium size, a great bearer, and of medium flavor; plant hardy and vigorous. This is used by some as a fertilizer, and answers well for this purpose; but for this region we prefer the *Large Early Scarlet*. *Lizzie Randolph* is a large, handsome berry; plants vigorous, and bear well; but, as far as we have seen, of poor flavor and quality. *Black Prince* generally bears an excellent crop with us. Many admire its peculiar, rich, mahogany color. The flavor this season, when fully ripe, was fine. On the whole, we put this among the best sorts. We see it has figured largely at the Kentucky exhibitions. *Bishop's Orange* and *Crimson Cone* are two old varieties that always yield well, and the fruit is of good quality; size medium. *Burr's Scarlet Melting* is a medium sized, tender fruit, and an immense bearer. *Jenny's Seedling* is a large, fine variety, that we think will prove valuable.

British Queen.—This magnificent English fruit, the queen of all strawberries, does not succeed well in this country; we have not seen a good specimen this year. It is almost abandoned; but we learn from the *Horticulturist* for July, that Dr. HULL, of Newburgh, has succeeded in raising a magnificent crop—Mr. DOWNING says, "much the finest flavored and most beautiful large strawberries that he has seen grown in this country. The color is darker, and they appear to have attained a perfection of quality never reached in England." We would cheerfully travel from Rochester to Newburgh to see better "*British Queens*" than we have seen in England.

Our seedling *Genesee* has sustained itself well; the crop this season was the best on our grounds. We know of no other variety that shows better in the bed; the fruit is so uniform, of a fine, clear, red color, and stands well up. It must become a valuable market sort, deficient in fine flavor.

Monroe Scarlet and *Orange Prolific* are both valuable seedlings of ours, great bearers and hardy. Our neighbors, Messrs. BISSELL & HOOKER, have also some seedlings that promise well.

We imported, last season, some six or eight famous new English sorts, but none of them have yet produced a crop to judge from or pass an opinion upon, except the *Bicton Pine*. This is a large, beautiful, high flavored berry, exceedingly fragrant; *white*, slightly tinged with rose. It bears well, and is really a novel and interesting acquisition.

If we live till next year, we hope to be able to record successful results from *Walker's Seedling*, *Moyamensing*, *McAvoy's No. 1* and *No. 12*, *Schneike's Hermaphrodite*, and many other native and foreign sorts that we shall have in a full bearing state.

THE DIFFERENT VARIETIES OF QUINCE.

BY B. DESPORTEZ, OF ANGERS, FRANCE.

The Angers quince. (*Coignassier d'Angers*.) Fig. 1.—The nurseries of Angers have

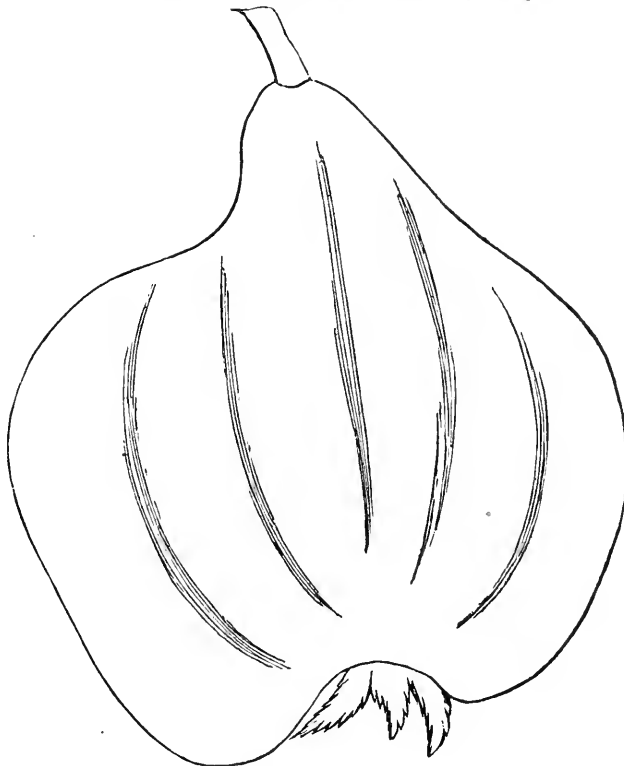

ANGERS QUINCE. Fig. 1.

for nearly a century, been the most extensive in France, and perhaps even on the whole continent. This branch of industry (which covers in the establishment of M. LE ROY, alone nearly 200 acres of land, and occupies 100 to 125 workmen, according to the season,) has by its intelligent labors produced some races of plants peculiar to the nurseries of this region. The most important of these without doubt, and that which has contributed largely to the prosperity of this horticultural town, is the *Angers Quince*. It has been said that this species was created expressly to receive the grafts of the pear. It is so extensively propagated, that all the country around for a consid-

erable distance is covered by nurseries occupied in greater part with this quince. It is not difficult to manage in regard to soil, and grows so rapidly that if planted in the

winter, it is fit to be worked (budded) in the August following, and in two years to be sold under the form of pyramidal pear trees—*poirier en pyramide*. The quantity of it exported annually, under the form of both quince and pear, is almost incalculable, and not only holds all parts of Europe, but Africa and the two Americas, tributary to this town for its products. It is the principal branch of commerce of the nurseries; and I should say even, that it has in greater part made their fortunes and reputation.

The tree has upright shoots when young, and few thorns or spines. The leaf is large. Fruit large, turbinate, largest in the middle, ribbed, and irregular. The stem is short, hard, and planted on the surface. The eye is large and wide; divisions of the calyx leafy and toothed; the basin of the eye is lightly ribbed or plaited. The skin is yellow, cottony, with some large dots of gray or black. The flesh is coarse and hard; juice acid, not abundant, and it has the same perfume as all the quinces. The quality is the same as the *Portugal*, and in this country it is the most fertile, and the species most commonly employed in making preserves. The flower is small, globular, bright rose; the petals are striped with lines of rose carmine extending from the base to the point; the flower bud is obtuse; the ovary is small and short; the sepals are small, and furnished on the under side with small points, and slightly downy.

After having made known the *Angers Quince*, a species

which is worthy of being more extensively cultivated than it is at present, it may be useful to give figures and descriptions of others, from specimens grown in M. LE ROY'S nurseries.

THE OBLONG QUINCE. (*Coing long ou oblong*.) Fig. 2.—Fruit very long and very irregular, largest in the middle, with cavities on the surface terminating abruptly toward

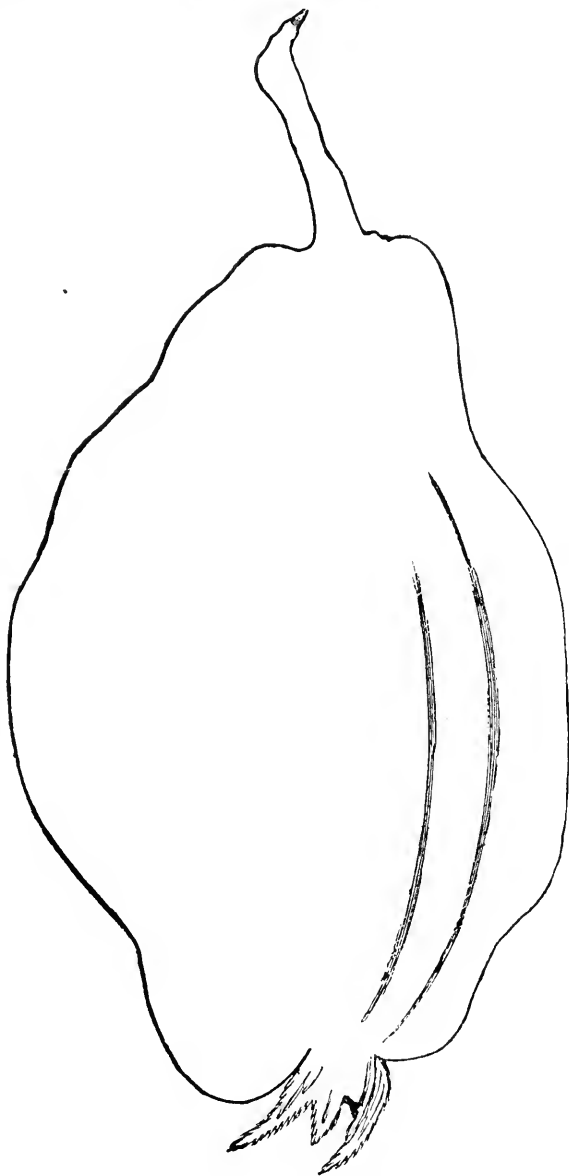

OBLONG QUINCE. Fig. 2.

the stem. *Eye leafy*; divisions of the calyx very long, placed in a deformed cavity. *Flesh* coarse, dry, spongy; quality *mediocre*. *Stem* obliquely inserted and very hard. Arrives at maturity in November. The *flower* is very large, much expanded; white, tinted lightly with rose; petals almost round, edges wavy, and lightly striped with rose in the interior; the flower bud is very large, largest in the middle, conical at the top; sepals long, elliptic, deeply toothed, and thickly covered with a whitish down; the ovary

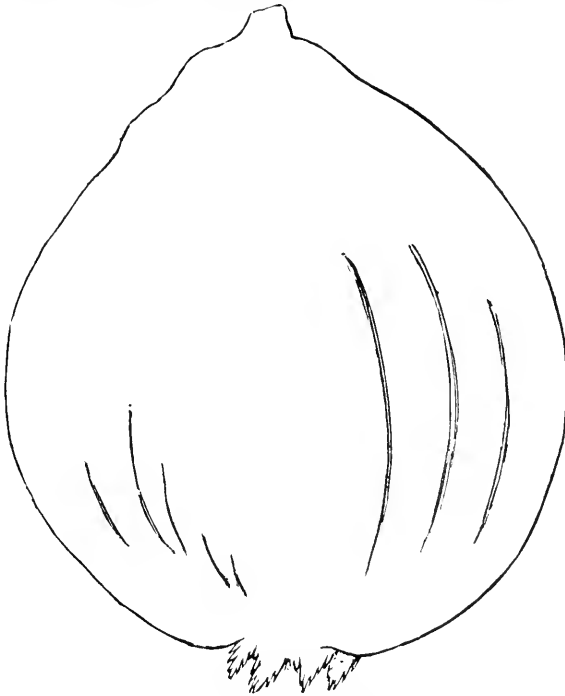

PEAR QUINCE. Fig. 3.

The *wood* is hard, its branches slender and twiggy. The *leaves* are small and downy. The *fruit* is large, regular although ribbed. It is of prett. good quality, and serves the same culinary purposes as the other species.

is large and long. The *leaf* is very large, wavy, swelled, downy underneath and smooth above; sometimes the leaves are long, elliptic, and lanceolate, at others round.

THE PEAR QUINCE. (*Coing poire*.) Fig. 3.—This variety is not cultivated in the nurseries at Angers, and it is with difficulty that one can procure it in this country. The only plant which I know is that in the specimen grounds of M. LE ROY. It is very common in the nurseries of other towns, particularly at Paris and Orleans, where the gardeners call it the "*Coignassier Femelle*" female quince. It is this which they use as a stock for their pears. Its vegetation is much more slow than that of the *Angers*, so that it can rarely be budded the same year it is planted.

NEW ROSES.

AMONG the new Hybrid Perpetual, or Remontant roses that have bloomed with us this season, are some excellent distinct varieties, that are very valuable additions to this interesting class of roses. We give the following garden notes of a few:

Baronne Hallez—Light crimson, with a carmine shade; beautifully formed; a good grower.

Caroline de Sansal—Pale flesh color; nearly as large and fine as *La Reine*; robust growth, and large foliage; decidedly the best light colored one we have yet seen.

Gen. Cavaignac—Rosy carmine; good shape.

Gen. Morangiez—Rosy pink; beautiful form and robust growth.

Eliza Balcomb—White with a fleshy tint; small, delicate, and pretty.

Pauline Buonaparte—Pure white; small; habit dwarf.

Madam Fremion—Bright rosy carmine; good shape; free growth; distinct and beautiful.

Madam Lamoriciere—Clear, transparent rose, under side of petals nearly white; perfect form; one of the very best; quite distinct.

Gen. Charnegarnier—Purplish crimson; very large; habit vigorous; distinct and fine.

Madam Trudeauux—Light crimson; large, finely formed; free growth; distinct.

Pius the 9th—Deep red, with a purplish tint; large and fine; robust, and a profuse bloomer; quite distinct.

Standard of Marengo.—Brilliant crimson; a beautiful rose, but not very double.

Reine des Fleurs—Pink, with a lilac shade; perfect form; a beautiful rose.

Commandant Fournier—Rosy red; a large, bright, showy rose.

Comte de Montalivet—Purplish crimson; very large, and finely formed.

Comte Bobrinsky—Brilliant scarlet, with a carmine shade; a striking, superb rose; dwarf habit.

Poniatowski (Vibert)—Dark, purplish crimson; outside dark, almost maroon; center light; changes; distinct and beautiful.

Nothing yet surpasses or equals the *Geant des Batailles* in dazzling brilliancy, nor *La Reine* in fullness and perfect form. *Baron Prevost*, *Duc d'Anjou*, *Wm. Jesse*, *Madam Laffay*, and *Robin Hood*, are also fine yet, and likely to remain valuable for some time.

PINNEY'S ORCHARDS.—H. P. NORTON, Esq., of Brockport, furnishes to the *Rural New Yorker* an account of the orchards of AUSTIN PINNEY, Esq., of Clarkson, N. Y., from which we learn that Mr. P. has now 3000 peach trees, 2600 pear trees on quince stock, 200 ditto on pear stock, making in all 5,800 trees. We know something of Mr. PINNEY'S zeal in fruit-culture, and with the finest land in the heart of the finest fruit-growing section of America, we do look for model orchards indeed. The splendid new railroad from Rochester to Niagara Falls runs through the village of Brockport a mile from Mr. P.'s farm, so that he is now fairly on the highway of life, and can dispatch his fruits, as they ripen, to the great markets that are anxiously awaiting them, both east and west. Success to PINNEY'S orchards.

NOTICING that Mr. SOUTHWORTH, of Penfield, (who you will remember was awarded our Society's first premium for *Burr's New Pine* strawberry,) was bringing large quantities of strawberries daily to market, I requested him to report his success in his first attempt at raising this fine fruit. His land is of a sandy loam, and he says that the frost never throws out the roots, by which they so often perish. Last season he planted out five-eighths of an acre of the vines of *Early Scarlet*, *Hovey's Seedling*, *Burr's New Pine*, and *Alpine*. His *Scarlets* produced early and well, and his entire crop he estimated at 2000 quarts, which he sold in our market at \$265. He has taken up his *Alpine*, and planted the same ground and half an acre more with *Burr's New Pine*, which he says bears double what the *Hoveys* do. JAS. H. WATTS.—Rochester, N. Y.

THE BLACK EXCRESCENCES on the shoots and limbs of plum trees are now coming, and they sometimes break out on the bodies of small trees in such a way that it is difficult to remove them with the knife, without cutting away the whole tree. I have this summer had three such cases, and have cut off most of the tumor and wet the remainder with spirits turpentine. The tumor in each case has ceased to grow and has perished. In the first instance the turpentine spread a little around the sore, and destroyed the life of the bark as far as it went. I was after that careful to wet only the tumor. The sores were on trees that I set this spring. None came on trees that I have kept for a few years with the ground well manured and salted. I esteem them a *scrofulous* disease of the tree. S. C. HAMILTON.—Buel, N. Y.

Ladies' Department.

CALANDRINIA.

THE ornamental species belonging to the genus *Calandrinia* are mostly natives of South America, and like the mignonette are shrubby plants there, though with us, and also in Europe, they are treated as annuals. The name *Calandrinia* was given to this genus in honor of L. CALANDRINI, an Italian botanist. We have many plants of this genus, but the only one that has yet flowered is the *Calandrinia Speciosa*, and of which the accom-



CALANDRINIA SPECIOSA.

panying engraving is a very good representation. Few flowers have a more striking effect than this little *Calandrinia*, with its brilliant dark crimson flowers peeping out from its thick and beautiful bed of leaves. The flowers open in the morning, and present as rich a mass of foliage and flowers as can be desired; but by three o'clock in the afternoon every little flower is closed. With the exception of the early closing of the petals, this species deserves to be generally cultivated, as nothing can exceed the rich velvety look of the flowers. It is quite hardy, a true annual, and ripens its seeds in great abundance. It is a native of Northern California, whence its seeds were sent to England in 1832, by DOUGLAS. It should be sown in dry and exposed situations, where it can have abundance of light and heat; as the situation in which DOUGLAS found it was a hot, dry bank. It requires very little water, and flourishes best in weather when

most other plants are burnt up. It is well adapted for rockwork. It may be sown two or three times during the season, and at any time from April to July.

Calandrinia Grandiflora is another species, the flowers of which were so much larger than those of the earlier introduced, that Dr. LINDLEY gave it the name of *Grandiflora*, or large-flowered; but the name seems now inappropriate, as the flowers of *Calandrinia Discolor*, or discolored *Calandrinia*, are more than twice as large, and is really the finest of the species.

Editor's Table.

TRIAL OF IMPLEMENTS AT GENEVA.—Our paper goes to press too early to permit us to give an account of this exhibition. A large number of Mowing, Reaping, and Threshing machines are entered for competition. On the first day the Mowers were tried, and the competition was very spirited. On the second day we witnessed the trial of Reapers, some eight in number. The trial was very satisfactory. The number of people assembled was not large at any one time.

TOWN AGRICULTURAL SOCIETIES.—A correspondent informs us that they intend getting up a Town Agricultural Society in Naples, Ontario county, N. Y., and asks our opinion of the plan. We cordially approve of it, and think its general adoption would be attended with great benefit to the agricultural interest. Not that we wish them to supersede the County and State Agricultural Societies, but to co-operate with them. The Town Fair should be held a few weeks previous to the County and State Societies, and selections be there made of articles to be sent to the County and State exhibitions. In this way we should have individual, town, county, and—when we have our National Agricultural Show—State competition, which cannot fail to facilitate the march of agricultural improvement.

RUSSELL COMSTOCK, the professed discoverer of "a natural law in vegetable growth and life," has been delivering lectures to the farmers in Western New York, the past few weeks, at a dollar a head. An introductory lecture was delivered in this city, which was not very satisfactory, as Mr. Comstock stated that he made it a point at that lecture not to say anything that would expose his system. He, however, told some large stories—such as raising fifteen hundred bushels of potatoes on an acre by his system, which he calls *Terra culture*. The lecture was attended by many of our most intelligent gardeners and nurserymen, who put many important questions to Mr. Comstock, which he declined answering until the *next lecture*. After that *next lecture* we may give our opinion of this new discovery.

P. S. Since writing the above, Mr. Comstock has called upon us, and we learn from him that it is not his intention to divulge his secret in Rochester, until two hundred have signified their intention of attending. If this number is obtained in season, Mr. Comstock will lecture on or about

the 21st of August. Mr. Comstock has been in town some six or eight weeks, and could at any time since his arrival have obtained an audience of from fifty to one hundred; and the fact that he refuses to lecture to this number, creates a little suspicion.

ZINC PAINT.—Oxide of lead for many years has been the main ingredient in all oil paint. This being a virulent poison, painters have always been subject to a disease called *Painters' Cholic*, the effects of this poison upon the system. We notice in a report of the Sanatory Committee of Paris, that in one year there were 302 cases in that city, of which number 12 died and one became insane. Many of the colors used are also poisonous, such as green from copper. M. LECAIRE, a house-painter of Paris, after trying a series of experiments for four years, with a view to remedy this evil, finally succeeded in not only obtaining a white paint that is entirely harmless, but also the colors; and his paints are represented by high French authority as being more durable, as well as more beautiful than the old. His discoveries are—

1st, A pure and dazzling White—the oxide of zinc.

2d, A gold, lemon, and straw Yellow—a preparation of the oxide of zinc.

3d, An excellent Red, having for its base sulphate of antimony.

4th, A number of fine Greens, resulting from the oxide of zinc and the sulphate of cobalt.

5th, A perfect drying oil, which is obtained by boiling 100 pounds of linseed oil with five pounds of per oxide of manganese.

We have examined the White Zinc Paint, at the store of M. F. REYNOLDS, who is the agent for this city, and for beauty and clearness it is far superior to any preparation of lead paint.

In Sussex county, N. J., large veins of zinc ore exist, and some years since an association under the name of "The New Jersey Zinc Company" was formed for manufacturing this ore into paint. The *Scientific American* says: "The Company about two years ago erected works on the Passaic river, near Newark, N. J., and manufactured white zinc paint, and various shades from a light cinnamon to a cinnabar color. The sales of the Company amount to seven tons of paint per day, and in a few years will amount to twenty tons."

JEFFERSON COUNTY FAIR.—The annual show of this Society is to be held at Watertown, on the 16th and 17th of September. In addition to the complete premium list offered, Messrs. HUNGERFORD and BRODIE give a challenge for a sweepstakes, for the best five Long Woolled ewes, not over two years old, owned in the State of New York. Their conditions are, that each intending competitor is to deposit the sum of \$10 with the Secretary of the Society, on or before the first of July next. The sheep to be exhibited at the time of the next Fair at Watertown, and the Judges to be the committee appointed by the Society, on Long Woolled sheep.

They also give a challenge for a sweepstakes, for the two best fat ewes, of any age, owned in this State. Conditions same as above.

AGRICULTURAL FAIRS.—Below we publish all the agricultural Fairs to be held this fall that have come to our knowledge. The officers of any that have been omitted will please notify us, giving time and place. Those sending notices in papers, will please mark them, or they may escape our notice.

STATE FAIRS.

New York, at Utica,.....	Sept. 7, 8, 9, 10
Ohio, at Cleveland,.....	" 15, 16, 17
Michigan, at Detroit,.....	" 22, 23, 24
Canada West, at Toronto,.....	" 21, 22, 23, 24
Vermont, at Rutland,.....	" 1, 2, 3
Pennsylvania,.....	Oct. 20, 21, 22
Wisconsin, at Milwaukee,.....	" 6, 7, 8
New Hampshire,.....	" 6, 7, 8
Georgia,.....	" 18 10 23
Maryland, at Baltimore,.....	" 26, 27, 28, 29
American Poinological Congress, at Philadelphia,.....	" 13
American Institute, at New York,.....	" 5
Exhib. of Stock,.....	" 19, 20, 21
Rhode Island Society of Improvement, at Providence,.....	Sept. 15, 16, 17
New England Society for Improvement of Poultry, at Boston,.....	" 7, 8, 9, 10

COUNTY FAIRS.

Saratoga, at Mechanicville,.....	Sept. 15, 16, 17
Rensselaer, at Troy,.....	" 22, 23, 24
Clinton, at Kesseville,.....	" 22, 23, 24
Essex, at Huntington,.....	" 20, 21, 22
Suffolk, at Huntington,.....	" 22, 23
Onsego, at Morris,.....	" 16, 17
Jefferson, at Watertown,.....	" 15, 16
Cortland,.....	" 21, 22
Greene, at Cairo,.....	" 29, 30
Columbia, at Chatham 4 Corners,.....	" 22, 23
Madison, at Eaton,.....	" 21, 22
Wayne, at Wolcott,.....	" 28, 29
do. at Palmyra,.....	" 22, 23, 24
Rensselaer, at Troy,.....	" 28, 29
Herkimer, at Herkimer,.....	" 29, 30
Ontario, at Canandaigua,.....	" 29, 30
Monroe, at Rochester,.....	" 22, 23
Wyoming, at Warsaw,.....	Oct. 14, 15
Seneca, at Waterloo,.....	" 6, 7
Genesee,.....	" 6, 7
Cayuga, at Auburn,.....	" 5, 6
Putnam, at Carmel,.....	" 17
Richmond,.....	" 22

TOWN FAIRS.

East Bloomfield,.....	Sept. 22
Brookfield, Madison county,.....	" 20, 30
Cape Vincent, Jefferson county,.....	" 15

THE JOURNAL OF THE U. S. AGRICULTURAL SOCIETY.—The Executive Committee of the U. S. Agricultural Society voted \$200 to get out the first number of the Journal, in which is contained an account of the doings of the National Agricultural Convention, and such other matter as may be deemed appropriate, and useful to the farming community. This work, which is expected to be issued quarterly, is placed in charge of DANIEL LEE, who is somewhat known to the readers of the *Genesee Farmer*. We can only say that the best talent in all the States is pledged to aid, hereafter, in making "The Journal of the United States Society" an honor to the first agricultural nation on the globe; and that such as desire to join the Society, and participate in the advantages which it offers, can do so by sending two dollars to WILLIAM SELDEN, Esq., Washington, D. C., Treasurer of the Society, or to DANIEL LEE, its Corresponding Secretary, who will see that all names are duly entered, and that the Journal, seeds, &c., are properly mailed. The first number of the Journal will be published in this month, (August,) and contain 144 pages.

It will be seen by Mr. DORR's advertisement, that he has changed the time and place of the sale of his Morgan colts.

ADVERTISEMENTS, to secure insertion in the Farmer, must be received as early as the 10th of the previous month, and be of such a character as to be of interest to farmers. We publish no other. Terms—\$2.00 for every hundred words, each insertion, *paid in advance*.

Inquiries and Answers.

CULTIVATION OF CELERY.—I find myself compelled to ask your counsel in regard to raising celery. I understand something about it theoretically, but wish to learn through the *Farmer* the whole practical part, from sowing till it is ready for the table, after which I can manage it. I have already trenched some, though I do not see how I can economically blanch it. Please teach me all you conveniently can in regard to it. CHARLES BRACKET.—*Rochester, Ind.*

Celery seed should be sown as early in the spring as the weather will admit. If sown in a hot-bed and transplanted when an inch and a half or two inches high into a bed in the open air, to strengthen, so much the better. Let them remain in this bed till four or five inches high, when they must be transplanted into trenches. The trenches should be dug about eighteen inches deep and four feet apart. Place some *well rotted*, rich manure about six inches thick at the bottom of the trench, and on the top of this some five or six inches of very rich surface soil or compost. In

the trench thus prepared, carefully transplant the celery plants about six inches apart, with as much earth remaining round the roots as possible; water them well for a few days; and if the weather is very hot, it will be necessary to shade them till they have taken firm root. They grow but slowly at first. Loosen the soil around them occasionally, and as they grow they must be earthed up. In doing this, be careful that the soil does not get between the leaves; take the leaves of the plant in one hand, and place the soil around it with the other to within a few inches of the top. Repeat the operation every week or so, as the plants grow, and you will have a crop of celery that will well repay all the labor. Before winter sets in, take it up and place it in the cellar with a little earth at the roots, and you can have celery until spring.

SMUT IN WHEAT.—I wish to make a few inquiries in regard to a subject very important to the farmers of this section of Kentucky. The wheat crop of this whole region is very much affected by a disease called the smut—a disease entirely new to this part of the country—the oldest inhabitants not having seen it before.

For fear there may be some misapprehension as regards the true affection, I will attempt a description of it as it appears here. There are no very marked differences in the heads of wheat until a few days before ripening; then the diseased heads appear more full and dark than the sound, and the capsules are in some instances filled with a dark grumous mass, and in others with a dark, impalpable powder, and emitting a most offensive and disgusting odor.

Can you, or some of your contributors, inform us in regard to its cure or prevention; and whether the disease is influenced by a wet or dry season; and also whether the disease is communicated when the grain is forming, or may it be produced (as some suppose) in sound wheat merely by bringing the smutted wheat in contact with it; or, in other words, whether wheat perfectly sound would another year be diseased by having come in contact with smutted heads now? All the information you can give us upon this subject, through the columns of your valuable and widely circulated journal, will be thankfully received by a subscriber. R. S. OWEN.—*Wilsonville, Ky.*

Few subjects connected with agriculture have been more discussed than that of smut in wheat; innumerable theories have been advanced to account for the cause, and as many remedies proposed for its prevention. Of these we can not now speak; our correspondent will find the matter discussed at full length in the *Farmer* of 1850. Whatever may be the cause, it is pretty certain that the prevention is easy and effectual in several ways. We know of nothing more simple and efficacious than to wet the wheat seed before sowing with a solution of salt and water, and drying it with caustic lime. The solution should be made so that an egg will just swim in it, and the seed be well wetted and limed *immediately previous to sowing*; for if it is left for many hours in a heap or in bags, it often heats, and the germinating principle is weakened or destroyed. Instead of salt and water, chamber lye is frequently used, and is, in our opinion, preferable.

WHEN TO SOW GRASS SEED.—I have been a subscriber to the *Farmer* for two years, and have carefully examined it to find some statement in regard to sowing grass seed, but have not been able to learn anything in regard to it. When is the best time to sow it—in the spring or fall? D. S. CHASE.—*Tekonsha, Mich.*

For permanent meadow, and on dry land, we should prefer to sow timothy seed in September, with the wheat, previous to the last dragging. The plant acquires a strong, vigorous growth during the fall, and will generally stand the winter, yielding a heavier crop of hay the first season than if sown in the spring, though it sometimes injures the wheat crop on land naturally inclined to grass.

If timothy alone is sown, from half a bushel to a bushel of seed per acre is necessary, according to the soil—clays requiring much more seed than rich, mellow loams. It is sometimes sown *alone* in August or September, and in this way a good crop of grass is often obtained the following summer.

Except in rare cases, we would never sow timothy on good wheat land, as a rotation crop; for being a cereal, it exhausts the soil of the same elements as wheat, and our wheat soils are not now any too rich, even under the best management. If timothy must be grown, let it be on land not well adapted to wheat; and on such soils it must be sown in the spring, as it is apt to winter-kill on low, alluvial land.

COOKING FOOD FOR HOGS.—I wish to make a few inquiries in regard to the feeding of swine, &c. Will a given amount of food produce a greater amount of pork if fed warm than if fed cold? It is the opinion of many old farmers in this vicinity that it will, especially if fed in winter. Will science bear them out in this opinion? They usually seal their Indian meal by the use of boiling water. Is this cooking it sufficiently? S. CARTER, JR.—*Amherst, New Hampshire.*

We have never made a satisfactory experiment on feeding hogs with cooked and uncooked corn meal, but have done so with barley meal and potatoes fed raw or uncooked, and with the potatoes steamed till they would beat to a pulp, and the barley meal mashed with them as soon as the potatoes were taken from the steamer. The result was decidedly in favor of the cooked food; so much so, that the plan was ever afterwards adopted, the extra increase of the hogs much more than covering the expense of cooking. The experiment was during the winter months, with six hogs in each sty.

BOXES FOR FEEDING CATTLE, &c.—I wish to make some boxes, from which my cattle may eat hay, straw, cornstalks, &c. What should be the form, size, &c.? Also some racks for sheep. What is the best form? Should the slats be far enough apart to allow them to pass their heads through? CYRUS BAINBRIDGE.—*Ronolles, N. Y.*

Will some of our experienced correspondents give their views on this subject?

HORTICULTURAL.

(D. E. G., Haviland Hollow, N. Y.) It makes no matter whether you take buds from dwarf trees or standards, or whether on quince or pear stocks, provided always the trees be in perfect health and vigor; this is the main consideration.

How will the plum succeed grafted on the peach? S. CARTER, JR.—*Amherst, N. H.*

Some varieties do well; but they must be in a light, dry soil.

MR. BARRY will confer a favor upon many of your subscribers, by stating in his department at what season it is best to transplant evergreens. N. W. T.

If from the nursery, any time in April or May; but if from the woods, about the time they are starting to grow.

Is the fall season as good as the spring for planting out fruit trees? And what month in the fall? CHAS. H. MORRISON.—*Oxford, Ia.*

For hardy trees, we prefer the fall, as soon as a sharp frost has completely arrested vegetation. In Western New York, about the 10th or 15th of October, and for a month after.

I WRITE to ask of you the kindness of letting us know through your columns, which is the very best work, in your knowledge, upon rural homes, giving also the address. We have heard of *Downing's Horticulturist*; if it is the best, please acquaint us with its address and terms.

Our situation will be on the edge of one of the many rich and beautiful prairies of Southern Illinois, overlooking an extensive undulating plain, bedecked the greater part of the season with sylvan groves and innumerable flowers. We wish to fix upon the plan for our yard, flower garden, fruit garden and orchard, the coming fall, and also for a nursery of evergreens and fruit trees; therefore we should like to be examining some excellent work upon this subject as soon as possible. We would of course wish one devoted almost exclusively to horticulture, as we have yours for agriculture, and one not lacking in engravings of sweet homes nestling in nature's green lap. E. J. COPE.—*Fairfield, Ill.*

Three good works for you—*Downing's Landscape Gardening, Wheeler's Rural Homes, Barry's Fruit Garden.*

WILL you please to give me some information, if you have had any experience in furring young fruit trees in the fall or beginning of winter, in order to protect them from the mice? If you have never experimented upon it, give your opinion as to its efficacy, and whether it will injure the trees or not. If it is a sure preventive, as I have heard it rumored, it will be one of the greatest blessings of the day to nurserymen and farmers. A. C. HALL.—*Morcy, Oneida Co., N. Y.*

We have had no experience with tar for this purpose, and should not advise its use. *Clean culture* around orchards is of great importance, and mice may be pretty effectually kept off by throwing up a small mound of earth around each tree, say a foot high, to be levelled down in the spring.

Emery & Co's Improved Horse Powers, Threshers, and Separators

THE undersigned have been appointed sole agents for the sale of Emery's new Patent Improved Horse-Powers, Threshers, and Separators, in the city of New York. The State Agricultural Warehouse is the only depot where this superior Power can be had.

LONGETT & GRIFFING,

7-ft. State Ag. Warehouse, 25 Cliff st., New York.

The Water Cure Journal.

A NEW VOLUME commences with the present July number. Published monthly. Illustrated with engravings exhibiting the structure, anatomy, and physiology of the human body, with familiar instructions to learners. It is emphatically a Journal of Health, designed to be a complete Family Guide in all diseases.

TERMS.—Only One Dollar a Year, in advance. Please address, post paid, FOWLERS AND WELLS, No. 131 Nassau street, New York.

A few brief Editorial Notices may be acceptable to those unacquainted with the Journal. We copy:

From the New York Tribune.

"The Water Cure Journal holds a high rank in the science of health; always ready, straight-forward and plain-spoken, it unfolds the law of our physical nature, without any pretensions to the technicalities of science, but in a form as attractive and refreshing as the sparkling element of which it treats."

From the Fountain Journal.

"Every man, woman, and child, who loves health, who desires happiness, its direct result, who wants to 'live while it does live,' 'live till he dies,' and really live, instead of being a mere walking corpse, should become at once a reader of this Journal, and practice its precepts."

From the New York Evening Post.

"THE WATER CURE JOURNAL.—This is, unquestionably, the most popular health Journal in the world."

THIS HYDROPATHIC JOURNAL now enters upon its Fourteenth Volume, with a circulation of FIFTY THOUSAND COPIES. The ablest medical writers are among its contributors, and all subjects relating to the Laws of Life, Health, and Happiness, may be found in its pages. Now is the time to subscribe. [8-24]

Hallock's Agricultural Warehouse,

No. 50, STATE ST., ROCHESTER, N. Y.

THE Subscriber, late from the Agricultural Works, Warehouse, and Seed Store of Messrs. Emery & Co., Albany, (where he has been engaged for the past six years,) has been induced to establish an Agency for the sale of their justly celebrated Premium Horse Powers, Threshers, Separators, &c., in Rochester. Particular attention will be paid to selling and putting up the Horse Powers, and other fixtures for threshing, &c. A thorough knowledge of these machines enables him to put them up more satisfactorily than has been done heretofore. Price and terms same as at Albany, transportation added.

He will keep for sale, Emery's Seed Planters, the best in use; Circular and Cross Cut Saw Mills, Feed Mills, Corn Stalk and Hay Cutters, Corn Shellers, Churning fixtures, &c., adapted to the Power.

Also, Reapers, Mowing Machines, Grain Drills, Plows, Harrows, Cultivators, Corn Shellers, Hay Cutters, Fan Mills, and agricultural and horticultural implements generally. He will be prepared to furnish dealers with Dunn and Taylor's well known Seythes; also, Manure, straw, and Hay Forks, Snaths, Rifles, and other haying tools, at manufacturers' prices, wholesale and retail.

Particular attention is called to A NEW PLOW, which is believed to be the best cast-iron Plow ever offered, and which is warranted to do better work, with less expense of team than any plow heretofore sold in Rochester, while the price is less than for any other equally well finished.

The "uniform one-price, cash system" will be adopted, with the prices as low as the cost of articles and just compensation for labor and time will allow. Farmers and others are invited to call and examine the stock of Machines and Implements,—and are assured no effort shall be wanting to meet promptly the wants of a discriminating public.

E. D. HALLOCK.

July, 1852.

Spanish and French Merino Sheep.

THE subscriber has on hand, and for sale, pure bred Spanish Merino bucks and ewes that are one year old, and one French buck three years old, and lambs that are half French and half Spanish, both bucks and ewes, that were sired by my imported buck that took the first premium at the State Fair at Rochester, in Sept., 1851.

REED BURRITT.

Burdett, Tomp. Co., N. Y., Aug., 1852.—8-16*

Great Sale of Superior Thorough-bred Short-Horn Cattle.

THE subscriber will offer for sale his entire herd of choice Short-Horns, comprising 50 head, young and old, at public auction, on Wednesday, the 13th of October, 1852, at 1 o'clock P. M., at his farm, 2½ miles from the city of Troy; reserving to himself one bid on 5 cows and heifers and one bull, say six head in all, and these to be pointed out previous to the commencement of the sale. This bid will be made public when the six animals are brought to the stand for sale. Should any gentleman advance on the single bid made by the proprietor, the highest bidder will be entitled to the animal. It is proper to say, the severe drought in this vicinity reducing the hay crop one half, has decided the proprietor to make this sale at the time named, instead of next June, which he had purposed to do.

The well established reputation of this herd in this Union, and in Canada, and the splendid herd it has measurably sprung from, viz: the famed herd of that eminent English breeder, the late Thomas Bates, Esq., renders it hardly necessary to comment upon its superior merits. It may not however be inappropriate to remark, that the establishment of this herd was commenced in 1838, and that the most careful attention has since been paid to its breeding, and that it now contains mostly all the reserved stock of two former public sales. Since 1840, the proprietor has imported from the late Mr. Bates, and his friends and late tenants the Messrs. Bell's, 7 head of Short-Horns. And besides these, he has now on the passage across the Atlantic, shipped 21st June, on board the packet ship Kossuth, Capt. Jas. B. Bell, a superior yearling roan bull, having many crosses of the famed Duchess bulls of Mr. Bates, including this latter animal and the two beautiful red roan 3 year old heifers which came out from England last September, "Yarm Lass" and "Yorkshire Countess" and the beautiful heifer calf of the latter animal, got in England by the Duchess bull "5th Duke of York," there will be 14 head of this imported stock, and its immediate descendants. There has been sold from this herd but 3 heifers from these importations, and these cows were sold at \$300 each. All the young bulls bred from these cows, except those now offered for sale, have also been sold at private sale, at \$300 each, most of them while quite young.

Besides these 14 head of high bred animals, the noble premium cow "Esterville 3d," bred by E. P. Prentice, Esq., of Albany, and her equally fine 2 year old, red and white heifer bred by me, got by the Bates bull "Meteor," and 3 of the famed milking Willey tribe, the same tribe of cows as the heifer "Ruby," sold by me to Mr. S. P. Chapman, of Madison county, and which cow was awarded the first premium by the N. Y. State Ag. Society, for producing the largest quantity of butter in ten days in June and ten days in August, on grass pasture only, being a fraction over 40 lbs. in those 20 days. There are other valuable tribes in the herd, as the printed catalogue will show.

The catalogue will be ready for distribution about the 1st of August, and will exhibit richness of pedigrees rarely to be met with, showing the descent of the most of the animals from the best animals on record in the English herd book. Having received an invitation from H. Stratford, last winter, to forward a list of the pedigrees of my herd, to be inserted in the forthcoming volumes of the English herd book of which Mr. Stratford is now the editor, several pedigrees were sent to him of the animals here offered for sale, and will appear in said book. Gentlemen are invited to examine the herd at any time.

A credit of 9 months will be given on all sums up to \$300, and 9 and 15 months on all sums over \$300, for approved paper, with interest, payable at some bank in this State. Troy, N. Y., August, 1852.—S. St. GEO. VAIL.

Albany Tile Works,

No. 60 Lancaster St., West of Medical College.

THE subscriber has now on hand, and is prepared to furnish to Agriculturists, Horse-Shoe and Sole Tile, for land drainage, of the most approved patterns. They are over 1 foot in length, 2½ to 4½ inches calibre, from \$12 to \$18 per 1000 pieces—being the cheapest and most durable article used. Orders from a distance will receive prompt attention. [4-6t] JOHN GOTT, Jr.

Mansfield's Clover Seed Hulling and Cleaning Machine

WAS awarded, at the Ohio State Fairs 1850 and 1851, the first premiums, Diploma and Silver Medal. Warranted to hull and clean from 20 to 40 bushels seed per day, or from two to five bushels per hour. Cash price of machine \$65. Manufactured and for sale by M. H. MANSFIELD, August, 1852.—S. 21* Ashland, Ohio.

Agricultural Implements & Machinery, Seeds, Fertilizers, &c.

FARMERS Planters, and Merchants, will find at the Agricultural Warehouse of A. B. Allen & Co., 183 and 191 Water street, New York, the largest assortment in the United States, of tools and machines, suited to every soil. Most of the implements sold by them are manufactured in their own machine shop, under the direct supervision of one of the firm, where the best of seasoned timber only is used, with iron of the first quality.

Plows.—Of plows they sell more than 100 different patterns, among which are double mouldboard, or fluke plows, self-sharpening, subsoil, and side-hill plows.

Flow CASTINGS of various patterns, among which are bull tongue, scooter, scrapers and shovels, by the ton or retail.

Harrow, Cultivators, Cotton Sweeps, Corn Planters, Hoes, Shovels, Spades, and Forks, of various patterns, in any quantity.

STRAW CUTTERS and CORN SHELLERS, manufactured with much care, extra strong.

Sugar Mills, Rice Hullers, Cotton Gins, Threshing Machines for wheat and oats and rice, Fanning Mills for do. Wheat and Corn Mills, with burr stones or iron plate.

HOESE POWERS of various patterns, suitable for one to eight horses.

REAPING and MOWING MACHINES, Sowing Machines, Grain Cradles, Scythes and Rakes. Every kind of Horticultural Tools; also,

GARDEN and FIELD SEEDS, Fruit and Ornamental Trees, sent to order.

IMPROVED STOCK.—Durham, Devon, and other cattle; Cotswold, Leicester, Southdown, Merino, and Saxon sheep; Suffolk, Lincoln, and Berkshire swine.

A descriptive, pictorial catalogue of over 100 pages will be given, on application from customers, or sent to them by mail on their enclosing four letter stamps, to prepay postage, as required by the present post-office law.

N. B. Genuine Peruvian Guano, Bonedust, &c.

THE PLOW,

A MONTHLY

PLANTERS' AND FARMERS' JOURNAL,

EDITED BY

SOLOMON ROBINSON,

is now published in place of the American Agriculturist, at FIFTY CENTS A YEAR. Editor's office at the New York Agricultural Warehouse. Specimen numbers will be forwarded, on application, to our correspondents.

A. B. ALLEN & CO.,

183 and 191 Water street, New York.

\$1000 CHALLENGE.

I OFFER to place one thousand dollars cash in the hands of a party chosen, against one thousand to be paid into the hands of the same party by any manufacturer of Threshers in the United States, if a machine can be found that will thresh and clean fit for market or seed, with the aid of *only two horses*, 100 bushels of wheat and rye in less time than I can with my "Excelsior Wrought Iron Cylindrical Thresher and Cleaner." The grain to be thoroughly threshed, without white caps, or broken, and the straw delivered long enough to stack, and free from chaff. The winner to receive the \$2000 with both machines and powers. For circulars, address Joseph G. Gilbert, 216 Pearl street, New York.

Emery and Co.'s advertisement in April number of Cultivator, with plates, termed by them "Emery's Improved Patent Rack and Pinion Power," I believe to be a direct infringement on "Urmly's Patent," and as attorney for Mr. Urmly I warn all who make or purchase a machine infringing on such patent, that they will be dealt with according to law. These powers can be procured from me only, at less prices than any other good railway power.

Gilbert's Patent Portable Excelsior Wrought Iron Thresher and Cleaner will thresh and clean grain fit for market at the rate of one-half to three-fourths of a bushel per minute, with two horses.

Urmly's Patent Railroad Power is the most durable and the cheapest power to be obtained.

Urmly's Double-gearing Lever Power, for 2 to 8 horses.

Urmly's Patent Cornstalk Cutter and Grinder.

Urmly's Patent Seed Drill. Over 2000 of these machines have been sold, and have given general satisfaction.—County rights for sale for \$100 and upwards, and castings furnished to manufacture at cost prices. Profits 100 per cent. For particulars, address, post paid,

J. G. GILBERT,

August, 1852.—S. 1t* \$2. 216 Pearl street, New York.

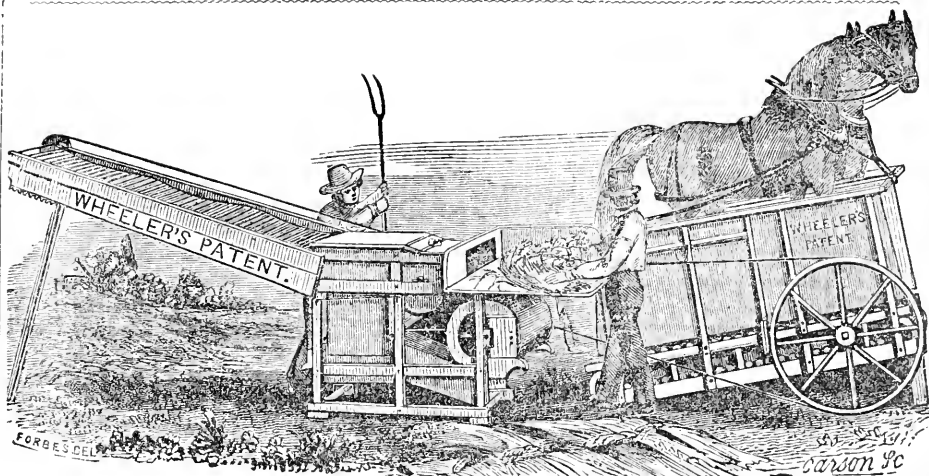

NEW YORK STATE
AGRICULTURAL WORKS,
ALBANY, N. Y.,

By Wheeler, Melick, & Co.

THE subscribers, in order to meet the rapidly increasing demand for their Horse-Powers and Threshers, and combined Threshers and Winnowers, and other machines, have recently added to their manufactory a commodious Furnace, so that every article of importance used in the construction of their machines, is now made under their immediate inspection. They are thus enabled to assure their customers that their work is of the most perfect character, both in workmanship and in the quality of the materials used; and in this respect, as well as in all other desirable qualities, they invite comparison of their agricultural machines with any others in the world.

Among the articles we make, are—

Wheeler's Patent Railway Chain Horse-Power, and Overshot Thresher and Separator, for either one or two horses.

Wheeler's Patent Combined Thresher and Winnowing, worked by only two horses.

Wheeler's Clover Huller, Straw and Stalk Cutter, Circular Saw-Mills, Horse Powers geared for churning in large dairies, &c., &c.

With the exception of the Combined Thresher and Winnowing, (which is a new invention of last year,) our machines are so widely known as to need no commendation. It is sufficient to say that every article made by us is warranted to give satisfaction, or it may be returned after a reasonable trial.

THE COMBINED THRESHER AND WINNOWER

was introduced into the market toward the close of last season, and is in exceeding high favor. We entertain no doubt that it is the most perfect, compact, and efficient machine now in use for threshing and winnowing grain, and it certainly is far the cheapest and most economical.

In our former advertisements in the April and May numbers of this journal, we gave numerous letters from persons who, having used the Winnowing, express the highest approbation of its merits. Since then we have received other testimonials of its excellence from gentlemen in different States of the Union, but we have space for only the two following:

From T. Waters, Esq., of Shop Spring, Tenn., dated June 24, 1852.

"MESSRS. WHEELER, MELICK, & Co.—I have just returned from W. T. Waters, whose Thresher and Winnowing was put in operation this morning. He is as well pleased with it as he anticipated. He can dispose of it at cost, and thinks he will do so, and order another machine from you. My own machine has not arrived."

From W. D. Bacon, of Wisconsin, dated July 2, 1852.

"MESSRS. WHEELER, MELICK, & Co.—I am using to-day the Thresher and Winnowing you sent me, and it far exceeds

my expectations in the perfect manner in which it performs its work. I have had several gentlemen witness its operation, and all concur that it is an extra machine."

We could add others equally flattering if space permitted.

Price of Double Power, with Combined Thresher and Winnowing, \$225
Price of Thresher and Winnowing without Power, 115

DOUBLE POWER AND OVERSHOT THRESHER AND SEPARATOR.

The superiority of Wheeler's Patent Railway Chain Horse-Power, and Overshot Thresher and Separator is universally acknowledged. Thousands of them are in use, many of which have threshed from 50,000 to 100,000 bushels of grain, and are still in good condition. Probably more than four times as many of these machines were sold during last year as of any other kind. They are beyond doubt the most durable and economical machine in use. Their capacity has been tested by repeated trials as well at the New York and Pennsylvania Fairs as on several private occasions in competition with another machine made in this city which has been advertised to be far superior to ours, and in every instance the result has been about one-third and in some instances more in favor of our machines. In every case except one, where we have submitted our machine to a working test at Fairs, it has taken the highest premiums; and in that excepted case the committee decided that our machine performed its work in 8 minutes and its competitor in 11¾ minutes, being nearly one-third in favor of ours.

We have also exhibited ours in competition with the same machine at the State Fairs in Ohio, Michigan, and Pennsylvania, and also at the Provincial Fair in Upper Canada, at all of which we received the highest premiums, viz: In Ohio, a Silver Medal and Diploma; in Michigan, \$20; in Pennsylvania, \$10; and in Canada, a Diploma.

We have numerous similar testimonials from county Societies, where we have always received the highest premiums awarded to Chain Powers.

Price of One Horse Power, Thresher, Separator, and Belting, \$120
Two Horse do., 145

SINGLE HORSE POWER AND THRESHER AND SEPARATOR.

This machine is well adapted to the use of farmers raising an ordinary quantity of grain; with two or three hands it is capable of threshing from 60 to 100 bushels of Wheat per day; or twice that quantity of Oats. The same power is also used for churning and for driving Circular and Cross Cut Saws, Cutting Feed, driving Grindstones, elevating Grain, pumping, &c.

Price of Power geared for churning and driving Cross Cut Saw and for Threshing, &c., \$92
Belt for driving Thresher, &c., 5
Thresher and Separator, 83

SINGLE HORSE POWER AND CHURNING MACHINE.

This machine has been extensively used in large dairies and with the most satisfactory results. The power is found to be peculiarly adapted to churning, the propelling force being produced by the weight of the horse to an amount sufficient to drive 4 or 5 barrel churns. The motion is varied by altering the elevation of the power so as to produce all the changes in speed required in the different stages of the process of churning. This is done by means of a lever and without stopping the horse, so that the motion is always under the control of the person in charge. The power is the same as that made by us for threshing, &c.

WHEELER'S FEED CUTTER.

This machine is made expressly for Horse Power use, and is very strong and substantial. It cuts not only corn stalks, but hay and straw with equal facility, and does its work with great rapidity. Price, \$25.

LAWRENCE'S SAW-MILL.

This mill is much used on railroads, for sawing wood for locomotives, as well as by farmers, for cutting stove fuel. With a one horse power it will cut from 10 to 15 cords of wood twice in two per day. Price, (with 24 inch saw,) \$35.

WHEELER'S CLOVER HULLER.

This machine is compact, simple and durable. It does its work perfectly without injuring the seed, and is capable of hulling from 5 to 15 bushels of clover seed per day, with one horse. Price, \$28.

TROJAN PLOW.

The subscribers are also the sole agents in Albany for the sale of the celebrated "*Trojan Plow*," made by N. B. Starbuck, of Troy. These plows are doubtless superior to any other kind in use, and will be sold by us at the manufacturer's prices.

☞ All machines made and sold by us are warranted to give satisfaction, or they may be returned after a reasonable time for trial. Orders are solicited and will be promptly filled.

WHEELER, MELICK, & CO.,

Corners of Hamilton, Liberty, and Pruyn streets,
(Near the Steamboat Landing,) Albany, N. Y.
August, 1852.

The subscribers have obtained from Messrs. Wheeler, Melick, & Co., of Albany, the exclusive sale in Rochester, and general agency in Western New York, of their celebrated Agricultural Machines, which we will sell at their Albany prices, adding transportation.

J. RAPALJE & CO.

Field Seeds.

AUSTRALIAN WHEAT—very superior. The berry of this grain is extra large, and makes the best of flour. It produces a greater average crop than any other variety now grown in New York. Several years' experience in its cultivation, proves that it is less liable to rust or mildew than other kinds; and as the stalk is large and strong, it is also less liable to blow down or lodge. Price, \$1 per bushel. Other varieties of wheat, such as the White Flint, Mediterranean, Black Sea, &c.

BUCKWHEAT, of the best kinds in market.

RUTA BAGA, or Swedish Turnep Seed. The Purple Top and other superior varieties.

TURNIP SEED—Large White Flat, Long White, Red Top Flat, Yellow Aberdeen, Yellow Stone, and other improved kinds for the field or garden. A. B. ALLEN & CO.,
June, 1852.—6-11. 189 & 191 Water st., New York.

Improved Subsoil Plows.

THE subscribers offer for sale an Improved Subsoil Plow, made under the advisement of Prof. J. J. Mapes, and free from the objections urged against those formerly in use. The wearing parts are so arranged that they may be easily and cheaply renewed, while the amount of force requisite to move them is less than half that required by those previously made.

Price—One Horse Plow, \$5; with draft rod, \$6. No. 1, with draft rods, \$5.50. No. 2, do., \$4.

LONGETT & GRIFFING,
June, 1852.—6-31. No. 25 Cliff street, New York.

Northern N. Y. Live Stock Insurance Company, Plattsburgh, N. Y. For terms, please apply to agents of the Company.

GREAT SALE OF BLOOD CATTLE.

ON Wednesday, the 18th of August next, I will sell the chief part of my large herd of Blood Cattle—chiefly cows, heifers, and heifer and bull calves—comprising upwards of fifty full-bred Short-Horns.

Also, eight thorough-bred Herefords—a two years old bull, a yearling bull, three cows, and three calves. One of the Hereford cows ("Rarity") was imported from England by Messrs. Corning & Sotham, in 1847. The others, excepting the two years old bull, are her descendants, by bulls of the same stock.

Also, two or three Devon bull calves, got by Mr. Ambrose Stevens' imported bull "Candy," bred by the distinguished Mr. Quarry, of Devonshire, England, and out of cows descended from the herd of the late Earl of Leicester.

The remainder of the cows and calves, forty to fifty in number, are high-bred Short-Horn grades, with a dash of Devon blood in some of them.

The calves of the thorough-bred Short-Horn and grade cows, are mostly got by the imported Short-Horn bull "Duke of Exeter," (10,152,) of the celebrated "Princess tribe," bred by Mr. John Stephenson, of Durham, England, whose herd is excelled by none, if equalled, by any now in England.

All the Short-Horn and grade cows and heifers which come in season, will be bulled, previous to the sale, by "Duke of Exeter."

Many of the cows, both thorough-bred and grade, are descended from the Bates bulls "Duke of Wellington," imported by George Vail, Esq., of Troy, N. Y.; and by "Symmetry," son of "Wellington," out of Mr. Vail's imported Bates cow "Duchess."

This stock has been bred with a strict regard to their milking quality, in which they have been fully proved, and are not excelled by any herd of cows in the United States. They are all gentle, with fine silky udders, milk easy, and are animals that will be satisfactory to any one in want of the best breeding and milking stock.

The sale will take place at the residence of Peter Gurbane, two miles above Albany, on the Troy road, on the homestead farm of Gen. Van Hensselaer, where the cattle will be for a week before the sale.

Catalogues with pedigrees will be prepared by the 15th of June, and sent by mail to all post-paid applicants.

I will also sell at the same time, two pairs of six years old thorough-bred Short-Horn oxen, and two or three pairs of matched steers.

Also, ten or twelve South-Down buck lambs, got by an imported ram, from the unrivalled flock of Jonas Webb, of Babraham, England, and from Ewes descended from the flocks of Mr. Webb, and Mr. Eilman of Sussex.

LEWIS F. ALLEN.

Black Rock, N. Y., May, 1852.—6-31*

French Zinc Paint.

THIS new and beautiful article of Paint is now offered to the trade and public, ground in prepared linseed oil, for the first time in this country. It has been used successfully in France for the last five years, where it has superseded white Lead as a paint.

The French Zinc when properly prepared and used, makes the most brilliant and durable white in use, and is entirely free from all poisonous qualities.

The French Zinc is not more expensive than white lead, and is prepared in such a manner that it requires no farther preparation for use, than to thin it with Turpentine or raw oil to the consistency of white lead paint.

The French Zinc is very much whiter, and has a better body, than the New Jersey Zinc.

The French Zinc is offered dry, and prepared as above, in quantities to suit purchasers, at the Manufacturer's Depot, No. 17 Buffalo st., Rochester, N. Y.

July, 1852,

M. F. REYNOLDS.

Real Estate for Sale.

THE health of the subscriber having failed him, he is induced to offer for sale his Mill property, consisting of a custom Mill, recently put in a good state of repair; a Saw Mill, also recently repaired; two Dwelling Houses; a good Orchard, and about 22 acres of land, including flowage land. Said property is situated in the pleasant town of Yates, Orleans Co., N. Y., in the midst of a wealthy farming community and an excellent wheat growing country.

He has also a farm of 154 acres of first quality land adjoining said Mills, 120 acres improved, good buildings, orchards, and plenty of running water. He will sell said farm with the Mills, if desired.

Inquire of the subscriber, on the premises.

[7-31]

J. C. PARSONS.

Prices of Agricultural Products at the Principal Markets in the United States. — July 21, 1852.

	New York.	Boston.	Rochester.	Chicago.	Cincinnati.	Philadelphia.
Beef, per 100 lbs.	<i>a</i> \$7.50	<i>a</i> \$7.25	\$5.50 <i>a</i> 6.00			
do mess, per bbl.	15.00 18.00	17.00 18.00	10.00 10.50			\$15.00 <i>a</i> 19.00
Pork, per 100 lbs.			7.00 7.50			
do mess, per bbl.	18.50 19.50	19.00 22.00	16.00 19.00	\$16.50 <i>a</i> 17.00		
Lard, per lb.	10 11½	11½ 12½	10 10	9 9½	8 <i>a</i> 10½	19.75 20.00
Butter, do.	12½ 21	15 23	12½ 17	7 7	9 12	10 11½
Cheese, do.	6½ 8	7 8½	6 6	5 6	6 6	12 14
Flour, per bbl.	4.00 5.87½	4.12 5.75	4.75 5.00	2.75 3.50	3.18 3.35	4.12½ 5.00
Wheat, per bush.	90 1.12	90 1.05	96 1.00		62 64	95 1.03
Corn, shelled, per bu.	62 62½	57 66	54 56	31 36	31 33	64 64
Rye, do.	40 44½	44 47	40 41	23 24½	24½ 25	43 46
Oats, do.	58 62		67 70		25 40	
Barley, do.	7½ <i>a</i> 8 pr. lb.	8 <i>a</i> 11 per lb.	5.50		3.75 4.00	4.57½ 5.00
Clay seed, do.	\$14 to 16 per tec.		2.25 3.00	2.25	1.50 2.50	
Timothy seed, do.	1.20 1.30	1.33 1.35	1.25 1.50	1.00	1.00	1.25
Flax seed, do.	16.00 20.00	14.00 15.00	8.00 12.00		6.50 12.00	
Hay, per ton.	31 48	50 30	40 40	23 36	26 37	34 50
Wool, per lb.		5.00 6.50	4.00 4.50			
Wood, hard, per cord						

CONTENTS OF THIS NUMBER.

Wheat Culture in New England.	233
National Agricultural Convention and Society.	235
Source of the Nutritious Property of Vegetation.	238
English and American Plowing.	240
Flax-Culture and Flax Cotton.	241
Thick and Thin Sowing.	243
French Merino Sheep.	247
CONDENSED CORRESPONDENCE.—Large Hog; Weight of Merino Lambs; Spanish Merino Sheep; Dropped Manure; To remove Garlic Taste in Butter; Plaster on Wheat in the Fall; Gapes in Chickens.	244
Impoverishing the Soil.	245
LADIES DEPARTMENT.—Calandrinia.	256
EDITOR'S TABLE.—Town Agricultural Societies; Zinc Paint.	257
Agricultural Fairs, Notices, &c.	258
Inquiries and Answers.	268
HORTICULTURAL DEPARTMENT.	
Notes on Strawberries.	150
The different varieties of Quince.	252
New Roses.	254
Answers to Correspondents.	260

ILLUSTRATIONS.

Group of French Merino Sheep.	243
Group of Silesian Merino Sheep.	249
Outline of Angers Quince.	252
Outline of Oblong Quince.	253
Outline of Pear Quince.	254
Calandrinia Speciosa.	256

Valuable Virginia Land for Sale.

I OFFER for sale between 700 and 800 acres of land, handsomely located in Prince George county, Va., lying immediately on Chipokaes creek, adjoining Lower Brandon plantation on the south, 25 miles from Petersburg. About 200 acres are cleared, and the balance tolerably well timbered with oak and pine. The cleared land was matted several years ago, and 1000 bushels of marl with 1500 bushels of lime have been recently applied to it.

The improvements there is a good brick house with five rooms, (from which there is a beautiful prospect of James river,) a kitchen, stable, smoke-house, a barn with stationary horse-power attached, and a well of good water. The buildings are within 300 yards of the main landing, where vessels load with produce, wood, &c., and unload lime at 7 cts. per bushel. Marl abounds on the opposite side of the creek. The whole tract is well watered by springs and brooks, that run through fine meadow lands, a part of which are cleared.

I will sell it entire, or in parcels to suit purchasers, as it can be advantageously divided into four farms. If not sold privately (of which due notice will be given) before the 30th day of September next, I will sell it upon the premises, on that day, at public auction, without reserve.

Persons wishing to view the property will leave the Richmond and Norfolk boat at Lower Brandon Wharf, on James River, three miles from the property; or I will give any information to those addressing me (post-paid) at Cabin Point P. O., Surry County, Va.

August, 1852.—S-2L.

E. T. FETTER.

Splendid Horses for Sale at Auction.

"We refer those who are critical in the matter of horse-flesh to the advertisement of J. Dorr, Esq., of Scottsville, by which it will be seen that his fine Morgan colts are offered for sale. Such an opportunity to purchase seldom occurs. Both the breed and these individual specimens are among the most desirable in the country."—*Rochester Daily American*, July 2, 1852.

See advertisement on page 232 (July number.) Sale to be August 25, at 3 P. M., in front of J. P. Fogg's seed store, Rochester, instead of 15th, at Scottsville, as before advertised. J. DORR.

Improved Stock.

CATTLE of the Durham, Devon, Hereford, Alderney, and Ayr-hire breeds.

SHEEP of the Native and French Merino, Saxony, South Down, and Cotswold.

PIGS of the Lincoln, Suffolk, and Berkshire breeds.

From our long experience as breeders and dealers in the above kinds of stock, and our excellent situation for purchasing and shipping, we think we can do as good justice to orders, as any other house in the United States.

A. B. ALLEN & CO.,

April 1, 1852—tf. 189 and 191 Water st., New York.

The Practical and Scientific Farmer's own Paper.

THE GENESEE FARMER,

A MONTHLY JOURNAL OF

AGRICULTURE AND HORTICULTURE,

ILLUSTRATED WITH NUMEROUS ENGRAVINGS OF

Farm Buildings, Domestic Animals, Implements, &c.

VOLUME XIII, FOR 1852.

DANIEL LEE & JAMES VICK, JR., EDITORS.

P. BARRY, Conductor of Horticultural Department.

Fifty Cents a Year, in Advance.

Five Copies for \$2—Eight Copies for \$3, and any larger number at the same rate.

All subscriptions to commence with the year, and the entire volume supplied to all subscribers.

Subscription money, if properly enclosed, may be sent (post-paid or free) at the risk of the Publisher. Address to

DANIEL LEE,
Rochester, N. Y.

December, 1851.

POSTAGE ON THE GENESEE FARMER.—50 miles or under, five cents per year; exceeding 50 miles and not over 300, ten cents; exceeding 300 and not over 1000, fifteen cents; exceeding 1000 and not over 2000, twenty cents; exceeding 2000 and not over 4000, twenty-five cents; for any distance exceeding 4000, thirty cents.

STEREOTYPED BY J. W. BROWN, ROCHESTER, N. Y.

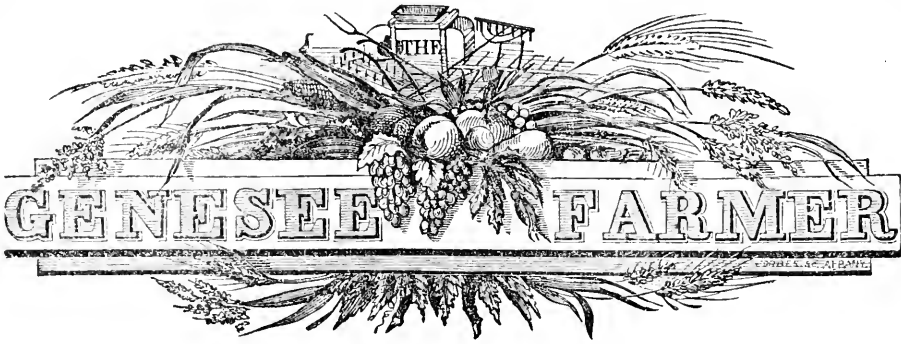

VOL. XIII.

ROCHESTER, N. Y., SEPTEMBER, 1852.

No. IX.

HOW CAN HE GET WISDOM THAT HOLDETH THE PLOW?

THE wisdom of a learned man cometh by opportunity of leisure. How can he get wisdom that holdeth the plow, that glorieth in the goad, that driveth oxen, and is occupied in their labors, and whose talk is of bullocks? — *Ecclesiasticus. Chap. 38, verses 24, 25.*

For three thousand years, and how much longer we know not, farmers have been reproached as stupid hinds, who had little "leisure to get wisdom," and less disposition to improve aright the "opportunities" which they possessed. Is it not time that all men identified with this great interest, should do something to increase the knowledge of farmers, who, we are told by the author above quoted, "are not sought for in public council"? Improved implements of tillage and husbandry have greatly diminished the labor of production, and agriculturists now enjoy, if they will, as much leisure for study, reflection, and the getting of wisdom, as any other class in society.

How to turn this leisure to the best account, is a question which every reader should deeply ponder. The careful reading of the works of wise men suggests itself as one means open to all, in this age of cheap books, for the increase of knowledge. But so far as agricultural arts and sciences are treated of, our books are sadly defective; and down to this hour, those most interested in their improvement have never so much as lifted a finger to make agricultural works what they ought to be. One can write as well as talk a great deal about the breeds of bullocks, and impart no instruction whatever; and for the best of all reasons, because the writer has no knowledge to communicate. Writing and printing signify little but the lamentable waste of the time of all readers, unless due care has been used to make the instructor worthy of his high calling. If a writer be ignorant of the principles of his profession, how can his darkness give light to others? If the science of farm economy is to be taught at all in this country, is it not high time that somebody be fully educated, to instruct us in this science? Unless something more is done to augment the knowledge of those that write for agricultural periodicals, how is it possible to maintain the interest, and steadily increase the value of these publications? If our teachers make no progress, can their pupils be expected to go far beyond them? Will it be said that in agricultural knowledge, all ideas of advancement are utopian and visionary? The farmer who lived in the time of Abraham cherished this stand-still notion, as "*he gave his mind to make furrows, and was diligent to give the kine fodder.*" Let us not be understood as undervaluing the devotion of "mind" to the making of furrows, nor the virtue of diligence in giving the kine fodder. It is the refusal to cultivate the mind as well as the soil, that we condemn. It is the everlasting degradation of the owner of the kine to their level, that we shall never cease to reprobate. It is that blind, mistaken policy, which excludes so large a share of the freeman of this Republic from its "councils," except as they are made the

tools of others, that we hope to see American farmers promptly repudiate. In many respects they occupy a false position, because they neglect to improve their leisure hours, and take little pains to carry the breeding of bullocks beyond the skill and practice of Jacob. We must improve the breeding of husbandmen, before they can do much to improve the breeding of cattle. Man is the starting point, and if the community do nothing for the professional education of working farmers, their advancement for the next three thousand years will be no greater than it has been during the last. Let every thinking person consider well this fact, and then co-operate with all that seek to elevate agriculture to the first rank among all learned and useful pursuits.

The natural sciences have been built up by repeated and careful experiments. These lead the critical investigator from things known to things unknown, which constitutes progress in knowledge. Practical and scientific researches into the laws that govern all constitutional changes in domestic animals, have never been made in this country. Why is this? The only satisfactory answer that can be given, is the unwillingness of farmers to encourage and support one experimental farm in any State in the confederacy. The census of 1850 shows that the value of the animals slaughtered in a year, for human food, is not far from one hundred and twenty million dollars. The cheap production of meat is, therefore, a matter of national importance; and who can doubt that a series of wisely directed experiments in the breeding, rearing, and fattening of neat cattle, hogs, and sheep, would throw new light on these important operations?

The popular taste for neat and commodious dwellings, comfortable out-buildings, beautiful and well cultivated gardens, fine orchards, and small, highly productive farms, needs to be fostered in every neighborhood over the whole length and breadth of the United States. How is this to be done? Not, certainly, by worshipping the almighty dollar, and disregarding everything else. Avarice is incompatible with the "wisdom of a learned man," and improves neither the social nor the moral faculties of the human family. To unlearn bad habits and traditions, is often the first and most difficult step toward reformation in the management of one's estate. Needful reforms in agriculture demand that great pains be taken to multiply examples of well conducted, beautiful farms, as models for the imitation of others. Perfect neatness and success may be attained without a fortune, as the basis of operations. By concentrating one's attention and means on a farm of moderate size, more comfort, and more money, as well as a more inviting appearance, will be realized. To make a wise use of capital is not so easy a task as some suppose: it requires sound judgment, experience, and cultivated common sense. Let the common sense of every farmer be properly cultivated, and we shall have no more occasion to ask for agricultural schools, and the systematic study of all the elements of soils, of cultivated plants and fruits, and of domesticated animals. The application of the best powers of intellect to the improvement of agriculture, aided by all needful funds and other appliances, will be made so soon as the people comprehend their true interests in this matter. It is uncultivated common sense that still asks: "How can he get wisdom that holdeth the plow, that glorieth in the goad, that driveth oxen, and is occupied with their labors, and whose talk is of bullocks?" Not to try to get wisdom is to take nature's bond that no wisdom shall be gotten. Wisdom exacts an honest and an earnest effort to obtain her fair hand; and none but simpletons expect to win her smiles by other means. That great wisdom and practical farming can grow up together, we religiously believe; and the steady increase of knowledge among the cultivators of the soil, until they shall stand, confessedly, the best educated men in the world, is the object aimed at by their humble servant. Their educational advantages are now extremely defective, and the proper remedy must be found and applied before many more years elapse. We must admit, however, that the locomotive of agricultural progress is not yet built; nor is the track laid on which it is to run. At present, very few are willing to take stock in the enterprise, and its friends are waiting patiently for a

favorable change in public opinion. Such a change is inevitable, although it may not come in the lifetime of the writer. All should plant good seed in the best soil that can be found, and leave the harvest, if need be, to the next generation. It is better to plant for posterity than not at all.

EXPERIMENTS ON DRAINING.

In the April number, page 109, will be found an article on underdraining, in which we detailed the best means to be adopted for removing stagnant and spring water from land, and also our opinion of the reason for and necessity of *under-draining*—making the soil a filter, in which the rain water, as it percolates through to the drains, shall leave its ammonia, the most important and beneficial of fertilizers, for the wheat and corn crops—thinking that a thorough system of under-draining would do more to remove the innumerable insects, blights, and rusts, which now make such fearful devastation on our crops, than all other modern improvements combined. We believe, also, that on most wheat soils—those even which are usually considered sufficiently dry already—under-draining would, for a few years at least, *add one half* to the present crops of wheat, clover, &c., and the land would ever afterward be permanently improved, the beneficial action of manure more apparent, and the soil be in that condition best suited to attract fertilizing gases from the atmosphere. There is no question but what underdraining has been the great means by which the agriculture of Great Britain has been so much improved during the last half century, and that its adoption would be equally beneficial on this continent.

Will it pay? is, therefore, the great question; for, if it will, there will be found no lack of energy and enterprise among our land-owning farmers, to push it forward with vigor. All that is necessary for its general adoption, is to show that it can be so done as to yield good profits. Where land is worth but \$15 or \$20 per acre, it may not pay to expend \$25 to \$30 per acre in underdraining it; but where undrained land is worth from \$60 to \$100 per acre, there can be no doubt that an additional \$30 per acre, judiciously expended in underdraining, would be a first rate investment. There is in most of our soils an abundance of organic and inorganic food of plants, which they can not obtain on account of stagnant water excluding the air, without which no healthy decomposition can take place, or plants thrive, and which underdraining would render in a fit state for assimilation.

In the *Transactions of the N. Y. State Ag. Society* for 1852, is given an account of experiments on draining, by Mr. JOHN JOHNSTON, of Seneca county, N. Y., and by the Hon. THERON C. YEOMANS, of Walworth, Wayne county, N. Y., to whom the Society has awarded premiums. The statements of these gentlemen are exceedingly interesting and instructive, and did the limits of our paper permit, we should like to lay the whole of them before our readers, but must be content to give extracts only. Mr. JOHNSTON'S farm is near Geneva, situated on the rich clay ridge which extends from the Seneca river southerly to Tompkins county—a ridge of land devoted chiefly to the cultivation of wheat. He has been making efforts for more perfect drainage since 1835, when he imported from Scotland some patterns of draining tile, and caused them to be made by hand in his neighborhood. The beneficial effects were such as to induce the Hon. JOHN DELAFIELD, Esq., to import in 1848 a machine for making tile in Seneca county, since which time the price of tile has been greatly reduced, and “no excuse exists for wet fields, or grain being destroyed by freezing out.”

“The question as to the depth of drains has always been one of interest, and some uncertainty. On this point I deem it absurd to propose any fixed rules, as the depth must depend upon the formation of the land and the nature of the soil. The rule adopted by me, is first to select a good outlet for the

water, then to dig a ditch so deep as to find a hard bottom, on which to lay the tile; yet I have laid many tiles on clay, and they have done well. On my farm this depth is generally found at two and a half to three feet. The distance between the drains is regulated by the character of the soil: if it is open or porous, drains three or four rods apart may thoroughly drain it; while on more tenacious soils, two rods apart may be needed. In most cases, where my fields lay nearly level, it has been found necessary to construct the drains nearer to each other, adopting as a rule, that the drains should always reach the point of the field where water is indicated to rise, and that is always at or near the highest part of the field, although that may only be observed when there is much water in the earth and the springs full, or when the field is in wheat or clover. At such elevations I put my drains deeper and near each other, to make sure to keep the water all under ground, using smaller tile leading to the main or submain drains. This rule has been important; for when opening ditches on the low ground, the water has flowed with such force as to induce most people to believe that it was derived from springs close by, when possibly the spring may be some sixty or eighty rods distant, at or near the most elevated part of the field, which, when reached, may save much expense in draining the lower lands. This shows the necessity of thoroughly examining in the wettest season the land to be drained. The main drains occupy the valleys or lowest grounds, receiving the lateral drains and collected water. They are constructed of larger tiles, and discretion and care are very necessary to proportion the main drains to the quantity of water to be discharged. In several instances I have found it necessary to lay a double row of four inch tile in main drains, to carry off the quantity of water collected by the smaller tile. I have generally used the half round, or horse shoe tile, as they are called. The four inch tile are in most cases large enough for main drains, and they will discharge a body of water far greater than most persons would believe, unless they witnessed their action. There may be places where larger tiles are needed. In one instance I found it necessary to use six inch tiles for sixty rods, and laid them in double rows. This would only be necessary where the thaws of early spring or heavy summer rains are apt to collect large quantities of water on the surface. To prevent a wash of the surface in such places, I have at regular distances filled the ditch directly over the tiles with small stones for a length of from twelve to eighteen inches, the stones to rise a little above the surface to prevent their being covered by the plow. Through these stones the surface water will pass rapidly down into the tiles, and be carried off at once. When the tiles are laid in the ditches with regularity and care, the earth is thrown in by a plow having a doubletree nine and a half feet long, to enable a horse to go on each side of the ditch, which is a rapid and economical way of filling them. In regard to cost, I find that drains constructed with two inch tiles can be finished complete for thirty cents per rod; yet something must depend on the digging, whether the earth be hard or soft, and the distance to draw the tiles. Mine have all been drawn five miles, and I find that two inch tile are large enough except for main and submain drains."

"About six years ago I began to drain a field on the boundary line between Mr. DELAFIELD and myself. The field contains about twenty acres, of which six were then subject to drainage. The six acres had seldom given a remunerating crop, even of grass. After draining the six acres, the whole field was plowed and prepared for corn, two acres being reserved for potatoes. The usual care was given to the cultivation of the whole crop, which during its growth showed a marked difference between the drained and undrained portions of the field. The yield of this field proved to be the largest ever raised, as I believe, in the county, the product being eighty-three bushels and over, per acre. When the corn was husked and hosed, it was weighed and measured in the ear, and allowing seventy-five pounds to the bushel for corn and cob, as has been customary in this region, the product was as above stated. This field attracted much attention from my neighbors and other gentlemen from more distant places. It was examined at the time of draining, and after plowing, both the first and second season, permitting the parties to walk on the drained parts without any undue moisture, while all other undrained land in the neighborhood was muddy; and, as before stated, the corn was found to be far more vigorous in the plant and abundant in the grain. In the following season after the corn I cropped it with barley, and found that the drained land produced altogether the finest plant and the best yield of grain. When the barley was harvested, I prepared the field and cropped it with wheat. The difference again was so striking and distinct in favor of the drained land, that I felt the propriety of thoroughly draining the whole field, which was completed without loss of time, at a cost of twenty-two dollars per acre. I then plowed and sowed with barley and seeded with clover. Of the latter I cut a very large crop last summer, and not one square foot of the clover froze out; and now I can rely on a good crop of anything I may sow or plant."

Mr. JOHNSTON has made sixteen miles of tile drains on his farm, and is so far satisfied with the results that he drained six acres last fall, and intends to do so till there is not a wet spot on the farm. He finds it difficult to state in figures the increased value of the drained land; but on such land as he has, if he gets two crops of wheat from the drained land, the excess of yield is sufficient to cover all expenses of draining, and sometimes the increase of one crop on the drained over the undrained land, more than pays for the cost of draining. Mr. YEOMANS, after detailing his mode of laying tile, which is very similar to Mr. JOHNSTON's, concludes thus:

"Some of the advantages derived from draining are, that the ground becomes about as dry in two or three days after the frost comes out in the spring, or after a heavy rain, as it would do in as many weeks before draining; enabling the farmer to work his land at almost any time he may desire to do so. It also dries it uniformly all over the field, so that in plowing he does not find spots of wet and dry, but is all in good condition at once. It causes the lowest places, which are generally too wet in seed time, and consequently produced but little if any crop, to produce the best of any part of the field, being generally the richest soil, from having had the wash of the surface of the land about it for many years.

"Some of the land I first drained had been planted with young orchard trees; and in the wettest places, some trees died the first winter and a greater number the second, and some young nursery trees on the same ground were nearly thrown out of the ground by the frost. After draining it, I replaced the orchard trees, and all have grown well, and the first crop of nursery trees, which I was compelled to remove to save them, before draining, have been replaced by others since draining, and they have succeeded perfectly; so that I may now well say, that if we desire to deprive Jack Frost of his power to do us harm, we should keep everything as dry as possible which is within his reach and liable to injury. And I am from my own experience fully convinced that, for whatever crop, and especially any crop liable to be injured by frost in winter, such as wheat, clover, &c., whether the season be wet or dry, if the soil retains its moisture too long at any season of the year, (and most soils do,) it will be materially benefitted by draining; and in fact I am well convinced that most of the winter-killed young fruit trees in many places, especially the peach, as well as the winter-killing of many valuable shrubs, vines, and evergreens, which survive the winter in some places in this latitude and are destroyed in others, is more to be attributed to excessive moisture in the soil during cold weather, than to all other causes combined.

"I will only estimate the increased value of the land by saying that I have the past year made over 1,200 rods on twenty acres, at a cost of about \$25 per acre, and that I should not permit such land to remain without such draining even were the expense doubled. Most of the lands so drained have been purchased by me immediately preceding the construction of the drains, and their very recent construction precludes the possibility of giving the specific and comparative productive capacity before and after draining, though on much of it very light crops have been grown for many years past, and no good crop of wheat has been raised on it for a long time; but the reason has not heretofore, to my knowledge, been ascribed to an excess of water, which I believe to have been the principal cause of the non-productiveness of the land. From the experience of two seasons on the small quantity first drained, I am of the opinion that the increased value of the land is much greater than the cost of constructing the drains, but more time is needed to fully test with accuracy the benefits to result therefrom."

ARTIFICIAL MANURES.

In the future of agriculture in this country, the manufacture of chemical manures is destined to occupy a most important position, and to be one of the principal means of improving it. It is therefore necessary, at the commencement of this movement, that chemists and the agricultural press generally, exercise caution and discrimination in the recommendation of the various articles now manufactured and offered for sale to the farmer as special fertilizers for this or that particular kind of crop; for by encouraging in any way the sale of a worthless article, the cause of agricultural advancement is seriously injured, and discredit brought upon all the recommendations of real science in the minds of the farming community.

In England an immense trade is carried on in the manufacture and adulteration of chemical manures, especially of superphosphate of lime. It is about ten years since this manure was first manufactured, and such has been its success that it has gradually increased in demand every year, till now many thousand tons are annually used as a special manure for the turnep crop. It has done as much to improve British agriculture as any one thing, by increasing the growth of ruta bagas, turneps, and other root crops, which being consumed on the farm by cattle and sheep, increase the quality and quantity of the manure heap, and, as a consequence, the average yield of wheat and other grains. And thus, while it is found that superphosphate of lime is of no value as a *direct* manure for wheat, and is not used for that purpose, yet its employment as a special manure for the turnep and clover crops has, by its good effect on them, *indirectly* increased the wheat crop to a considerable degree. It is manufactured from finely

ground coprolites, containing 55 per cent. bone-earth phosphate, and sold for *one cent per pound*. This is a good article, and is extensively used; but there is some prejudice against it in the minds of farmers, because it is made from a *mineral phosphate*. Another article, somewhat superior, manufactured from Saldanna bay guano, animal charcoal, and bones, sells for one and a half cents per pound.

Some time last year several deposits of nearly pure phosphate of lime were discovered in two or more districts in the United States, and the fact was extensively announced as a great blessing to the agricultural community. We thought that it would be immediately manufactured into superphosphate of lime, and sold to our farmers at a reasonable price; and that with it the growth of root crops would greatly extend. We were indeed informed that arrangements had been made by the owners of the deposits for its manufacture and sale, and accordingly recommended our readers to purchase and try it as a manure for those crops which experience and experiment proved it would greatly improve; and also stated what crops it would not benefit, as found by direct and extensive experiments in England.

We have recently received two samples of superphosphate of lime, manufactured in New York city, one called "*improved superphosphate of lime*," and the other, "*superphosphate of lime*." Both are offered at the same price—two and a half cents per pound. If the samples sent us are fair specimens of the articles, we should prefer the plain superphosphate as a manure for root crops, from the fact that it is the best manufactured article; the bones are all acted on by the acid, and the sample is in a finely powdered state; while the "*improved*" article contains quite a large quantity of undecomposed bones, or animal charcoal. We do not say that sufficient sulphuric acid has not been used, for indeed we know from experience that it is next to impossible to get a good article of phosphate of lime from burnt bones, or animal charcoal, unless they are reduced to a fine powder previous to the addition of the acid. The "*improvement*" is stated to be the addition of Peruvian guano and sulphate of ammonia. For wheat crops the addition of these substances is a great improvement, and the manure would be valuable for wheat in the exact proportion in which they made a part of its composition. Good Peruvian guano should contain 16 per cent. of ammonia, and about 20 per cent. of phosphate of lime. The commercial sulphate of ammonia, manufactured from gas liquor, contains about 20 per cent. of ammonia. The superphosphate of lime, made either from the mineral phosphate of lime or from animal charcoal, or burnt bones, would contain no ammonia; and the addition of sulphate of ammonia and guano, is to supply this deficiency, and to make a manure that would correspond more with that made from *unburnt bones*.

In purchasing an artificial manure for the wheat crop, *ammonia* is decidedly the most essential and expensive ingredient, and the price of the article is regulated by the quantity which it contains. In England, phosphate of lime can be purchased for, and is valued at, one and a half cents per pound, while ammonia cannot be purchased for less than twelve cents per pound, and is really worth more. As a manure for turneps, however, a manure is valuable in the proportion it contains of *bi-phosphate of lime*—this substance, from its solubility, having a most magical effect on that crop; and it is to convert the insoluble phosphate of lime into *bi-* or *super-phosphate*, that sulphuric acid is employed in the manufacture of the article. Soluble bi-phosphate of lime is valued at eight cents per pound.

If, however, we admit that phosphate of lime is a necessary ingredient in a special manure for wheat, Peruvian guano would at present be much the cheapest source of it; for, in addition to the 16 per cent. of ammonia, it contains 20 per cent. of phosphate of lime in first rate condition for assimilation by the plant, as well as other fertilizing ingredients of minor importance. As a manure for wheat, therefore, we greatly prefer

good Peruvian guano, even to this *improved* superphosphate of lime, especially if the sample sent us is a fair specimen of the article.

As conservators of the agricultural interest, we make these remarks simply to put farmers on their guard against the *indiscriminate* use of these various artificial manures; and that, if they try them (as we hope they will on a small scale as manures for wheat this year,) and the result is not beneficial, they may not *indiscriminately* condemn all book-farming, science, and artificial fertilizers as unmitigated humbugs.

SOIL BEST ADAPTED FOR THE CULTURE OF WHEAT.

ALL of our commonly cultivated plants are composed precisely of the same elements, the only chemical difference between the vast varieties of plants being the *relative proportion* in which the *same elements* unite to form the plant; so that if a soil will produce any one of our cultivated crops, it possesses the capacity, so far as the elements of plants are concerned, of growing any other crop, to some extent. In judging of the best kind of plants to be cultivated on any particular soil, therefore, we have to look to the relative proportion in which the elements of plants exist in the soil, and adopt that class of plants which requires most of the particular elements in which the soil abounds, or *requires least of those in which it is deficient*. This would seem to be a common sense view of the subject, yet there are many other circumstances, often overlooked, which, if considered, would materially affect our conclusions. In a large crop of corn there are all the elements which a large crop of wheat contains, and also in larger quantities, yet there are thousands of acres of land that produce immense crops of corn that cannot be profitably cultivated with wheat. A good wheat soil will always produce a good crop of corn, if properly tilled, while much of our best corn land will not produce wheat under ordinary culture. The cause of this great difference is not, we have shown, owing to a deficiency in the soil of any element of the wheat plant; for the requirements of the corn crop are identical in kind and greater in quantity, than that of wheat. It must, therefore, be owing either to the manner in which the various elements are assimilated by the plant, or to the existence in the soil of some substance, which though sufficient of it may exist in a corn soil for the actual demands of the wheat crop, yet from the different habits of growth of the two plants, a much larger quantity may be necessary for the performance of the healthy functions of the wheat than of the corn plant. This substance is most probably clay; for all soils which experience proves to be best adapted to wheat culture, abound with this substance and lime. The reason why clay is so much more necessary and beneficial for wheat than for corn, is not clearly understood. In light soil the wheat plant is found to throw out its lateral roots very near the surface, while in a clayey or heavy one it is more inclined to tap, and the lateral, fibrous roots are at a greater depth. In the former case the plant would be more exposed to the influence of frost and thaw, and would be more likely to heave out in the spring, while in the latter it would be better able to stand all the vicissitudes of cold and heat, from the roots being at a greater depth, and having a firmer hold of the soil. It is therefore probable that one of the benefits which the wheat plant derives from clay, is its preventing the extension of fibrous surface roots, and forcing the plant to throw out a single *tap* root, which descends much deeper and takes a firmer hold of the soil.

If this is a right view of the subject, we should loosen the subsoil of all our wheat fields, by deep plowing and subsoiling; while on soils rather too light for wheat, every possible means should be used to render the *surface soil compact and firm*. Treading the wheat in the fall with sheep has been practiced with advantage; but in doing so, caution is necessary to prevent serious injury in case winter immediately sets in. On all soils

which produce good crops of corn, we believe wheat may be grown, inasmuch as there is nothing lacking which enters into the wheat plant, and all that is necessary is to impart to the soil a certain degree of texture and tenacity, which all good natural wheat soils possess. For this purpose, heavy rollers and other mechanical means must be employed; and a presser something similar to *Croskill's Clod Crusher*, of which we have often spoken, would be of great benefit. We do not wish to be understood to say that consolidation is the only thing necessary *in all cases*, to ensure a wheat crop on soil where corn, barley, and oats flourish; for the land may in winter be so wet as to destroy the plant: yet if drained, and means be taken to render the surface compact, we believe such soils would produce first rate crops of wheat.

LEACHED ASHES ON WHEAT.

WHATEVER difference of opinion there may be respecting the particular ingredients to which the fertilizing power of leached ashes are owing, nearly all agree that they are a valuable manure for the wheat crop. And as there are, in different parts of the country, old asheries from whence old leached ashes can be obtained at a mere nominal price, we are surprized that they are not much more extensively used than they are. The good effects of 100 to 200 bushels of old leached ashes per acre are most decided on all light wheat soils, and are visible often for years after their application. This prolonged benefit is probably derived from the lime, of which the leached ashes contain some 30 per cent. It is not impossible, however, that leached ashes contain the double salt of silicate of alumina and soda, which Prof. WAX found was the real agent of soils in retaining ammonia and other fertilizers, and that therefore by adding leached ashes, we add ammonia, or at least the means of obtaining it from the atmosphere in the most available form for the wheat plant; and that it is this alkali that so much benefits the crop, and not the potash and soda which may be left undissolved from the ashes. If this is the case, the older the leached ashes are, the better;—the more they have been exposed to rain and the air, the more ammonia will they contain, and the more good will they do to the wheat crop. And it would indicate that on all our wheat soils leached ashes would do more good than the unleached ashes, from the fact that ammonia is so much more necessary as a manure for wheat than the alkalies potash and soda, which are washed out in leaching.

These views, however, are at present somewhat hypothetical, and further experiments are necessary to confirm or refute them; yet the *fact* that leached ashes are a first rate fertilizer, remains a fact still, though we cannot decidedly account for their good effect; and we would recommend all farmers who can obtain them, to do so, and apply them to their light soils previous to sowing wheat this month.

LICE ON HOGS—A REMEDY.—“BROOMSEDGE” complains in the *New York Plow* for August, that his hogs have suffered much from lice, and asks the editor or some correspondent, for a remedy. As the subject is of general interest, we suggest *sulphur*, to be given in food eaten by the swine, as a preventive. This well known mineral is particularly obnoxious to all insects, and has never failed to clear cattle of ticks when fed to them in their salt. The itch or scab insect that burrows in the skins of sheep, is destroyed by sulphur; and we doubt not that lice on hogs and calves may be driven off by the same remedy. It is said to clear fruit trees of parasitic insects and fungi, either by filling with sulphur holes bored into their trunks, which are then plugged, or by putting it around their roots. We hope that “BROOMSEDGE” will try this remedy, and report the result.

PEAS, AND PORK-MAKING.

In the great corn-growing districts of the western States, corn is doubtless the best food that can be raised for fattening hogs, and that system of feeding best that is attended with least labor and outlay. Grinding or cooking food is of very questionable economy where corn is worth only ten to twenty-five cents per bushel, yet it is in such places that pork-raising is a *directly* profitable business; that is to say, it pays much better to convert corn into pork than to sell it off the farm, *without reckoning the value of the manure in the calculation*. This arises from the fact that the relative difference between the price of corn and pork is there much more in favor of the pork than in this and the older settled States, owing to the cheap rate, compared with value, at which pork can be sent to the eastern cities. In feeding hogs, however, with corn at fifty cents per bushel and pork at four dollars per hundred, we have to be careful and economical of *corn* rather than of *labor*, to make it pay. Grinding and cooking, or soaking in water for twelve hours or so, will well repay the extra labor and expense. It is, however, doubtful whether, taking no account of the manure, it is profitable to feed corn to hogs at fifty cents per bushel, and pork at four cents per pound. Many good farmers think it will not, and keep only sufficient hogs to eat up what would otherwise be wasted, making their pork in summer on sour milk, and finishing off with apples, small potatoes, pumpkins, and "nubbins," or immature corn, in addition to the milk. In this way the actual cost of pork-making is little more than the labor, and the profit considerable. But this system is necessarily limited, and what is required is a profitable plan for feeding hogs, &c., on a large scale, it being otherwise impossible to maintain our farms in a high degree of fertility; that is, we can not export a greater part of the hay, corn, &c., from a farm, and keep it in good heart—without, indeed, we purchase instead of making manure, which in many localities is probably the cheapest way. But, as a general rule, our farmers must keep more stock, make more pork, mutton, and beef, on their farms, before the maximum produce of the soil can be obtained, or rationally expected.

In a judicious system of farm management, we must judge of the economy of growing a certain crop, or feeding with a particular kind of produce, by its effects on other crops of equal or greater importance. Thus, on wheat-growing farms, we have to look not merely to the profit of growing one crop, or feeding, &c., alone, but also to the effect it has on the ultimate object—the production of wheat. And that system of farming is best which yields the most profit *as a whole*, even though actual loss is sustained by growing and feeding out some of the crops, &c. In fattening hogs, therefore, we have to consider what will be the best method to adopt, taking into account the expense at which the food used can be grown, the effect of its growth on the soil, the amount of pork it will produce, and the value of the manure made by its consumption. To determine these points satisfactorily, requires more knowledge than we at present possess; and a series of experiments are needed before we shall be much wiser. It is really known, however, that the principal object on a wheat farm should be the *accumulation of ammonia*; for it is impossible in any other way to increase the wheat crop, which on most soils increases or diminishes as ammonia is supplied or withheld as manure. The wheat plant not only consumes, but actually *destroys* ammonia, during its growth. Corn, barley, and oats, are supposed, from good reasons, to do the same; and therefore none of them is the crop which we should grow for the purpose of feeding out on the farm, with the object of obtaining ammonia for the wheat crop. But *peas* do not destroy ammonia to any extent in their growth, and contain four times as much nitrogen (the essential element of ammonia) as corn; so that not only is a crop of peas produced without much destruction of ammonia, but the manure made by hogs eating them would contain four times as much ammonia as that made by those eating corn,

and would therefore be four times as valuable as a manure for wheat. Foods, too, containing a high percentage of nitrogen are highly nutritious; and not only are they best adapted for supplying the wear and tear of animal tissues in working horses and cattle, but experiments prove that they will actually produce the most fat and butter, although these substances contain no nitrogen. Hence we may expect that, weight for weight, peas will make more pork, mutton, or beef, than corn, barley, or oats.

Raising a crop of peas is attended with much less labor than a crop of corn, it is a first rate preparative for a wheat crop, and is off the land in good time for preparing it for wheat sowing. The principal objection to growing peas in Western New York, is the destructiveness of the "pea bug;" but if we grow peas as here advocated, for feeding hogs, this difficulty is removed, from the fact that the bug does little injury to the pea till late in the fall, or winter, and in feeding them to hogs they may be given as soon as harvested, and may be all eaten and the hogs ready to butcher before cold weather sets in and renders more food and attention necessary. Peas are first rate food for horses, cattle, and sheep; but for the horse especially they should be very dry, and therefore it is not desirable to feed them to him soon after cutting. So that, during the prevalence of the pea bug, the hog appears to be the best animal for feeding with peas, and answers every purpose. The pork or bacon from pea-fatted hogs is considered firmer and of altogether a superior quality. We would recommend that the peas be soaked in cold water from twelve to twenty-four hours before feeding to hogs.

In making these remarks, it is not intended to underrate our grand natural crop, maize. In many districts this is the best crop that can be grown for all purposes; yet on wheat farms, where the principal object is the growth of wheat, we would not grow corn for the purpose of feeding hogs—peas being a better crop, because produced at less expense to the soil, and affording the most valuable manure for the wheat crop.

IMPROVED BREEDS OF CATTLE IN THE WEST.

No country in the world is better adapted to the raising of cattle and sheep than our own great Western States, where land is not only plentiful and cheap, but of unequalled fertility, yielding rich natural grasses in great abundance. This undoubted fertility of the soil for grazing purposes, the fine dry climate, the cheapness of land, and the high price of labor, all point to stock-raising and wool-growing as the most profitable department of farm economy in the west. In no country can improved breeds of cattle be so readily and profitably introduced as in the new States of this Union. It is therefore gratifying to observe that our western brethren are making most praiseworthy efforts to improve their breeds of cattle, by importations from the Eastern States and Europe. Last spring a company of intelligent farmers was formed in the Sciota Valley, (Ohio,) for the purpose of importing cattle and improving their present stock, though it is now by no means inferior to any, common in the country. Two good judges were sent to England, in furtherance of the object, and it appears they have purchased and shipped for New York, twenty head of very fine cattle from the north of England, and also intend getting a first rate stallion. These cattle, it is said, will be exhibited in Cleveland, at the Ohio State Fair. The celebrated Short-Horn bull "Lamartine" has been hired by CALVIN FLETCHER, of Indiana, for the sum of \$200 for one season. This, with "Earl Seaham," gives that State the two best Durham bulls in the country. The other day, likewise, we saw passing through this city two very fine young Short-Horn bulls from Col. SHERWOOD'S stock, in the possession of A. C. STEVENSON, Esq., of Monroe, Indiana, where we believe that gentleman has already a fine herd of cattle, into which however he wishes to infuse a little fresh blood. Mr. S.'s stock must be very fine indeed if these bulls do not improve it.

From these indications, and many others that might be mentioned, we believe the farmers of the great west are waking up to the fact that it is quite as easy to breed good animals as poor ones, and that the cost of food for the one is no more than for the other, while the difference in nett profit is such as to astonish the natives. The Durham, or Short-Horn, appears to be the most favorite breed, judging from the number and the price at which they are purchased.

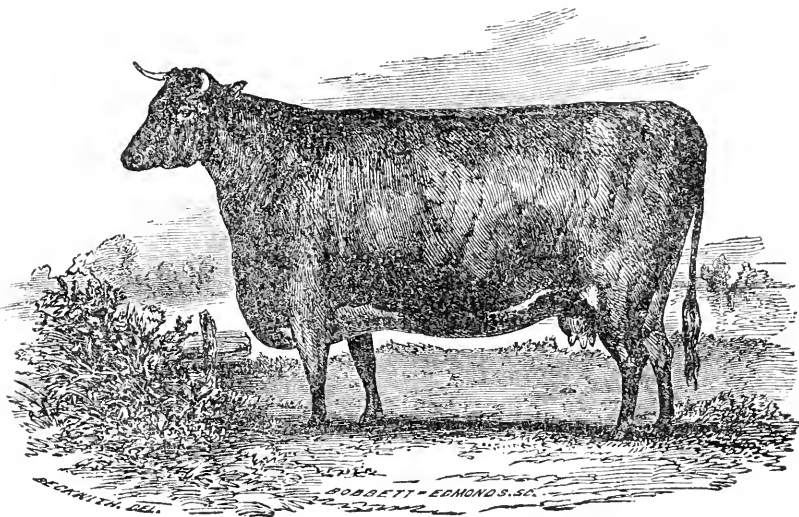

AZALIA.

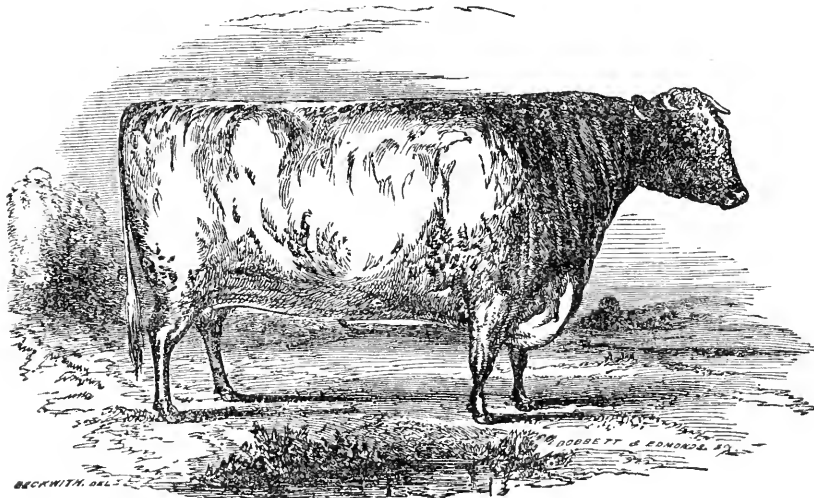

LORD EYRHOLM.

The accompanying cuts are good representations of this deservedly much esteemed breed of cattle. "Lord Eyrholme" obtained the first premium as the best two year old Short-Horn bull, and "Azalia" as the best Short-Horn cow over three years old, at the New York State Fair in Rochester last year. They are owned by L. G. MORRIS, of Mount Fordham, Westchester county, N. Y.

The Durhams are generally admitted to be the best breed for rapid feeding and early maturity, being perfect at three years old. Their milking qualities are said to be good; but good fat-makers and milkers seldom go together. They require good, rich pasture, and proper attention in winter. If these are given, the breed can not be beaten for beef-making. A cross between a Short-Horn bull and a Native cow, gives a valuable breed for dairy purposes. Some, however, prefer a cross with the Devon. The Devon, too, is undoubtedly the best bull to use when working cattle are desired. It is likewise said that the Devons stand the winter better than the Durhams. But we must not draw comparisons, else we shall pull an old house on our heads.

THE ELEMENTS OF FERTILITY WORSE THAN WASTED.

THE advantage, if not the necessity, of supplying ammonia or substances rich in nitrogen as manure to our wheat crop, is now universally admitted; and we will once again call attention to the great loss which the country sustains in the waste of ammoniacal manures in cities and villages, where they so often generate cholera and other pestilential diseases. All medical experience goes to prove that those organized substances, whether vegetable or animal, that most abound in nitrogen, evolve gases of the most malignant character, when they rot. No other cultivated vegetable, stored up in cities, has generated in its unexpected decay, so much pestilence as cabbage; and no other has so much nitrogen in its composition, nor so much sulphur and phosphorus. The gaseous compounds of these elementary bodies are now carrying death into thousands of families; but the careful study of these elements of pestilence and of human food, who will encourage? The good people of Rochester are now afflicted with cholera, and many have left the city in consequence, when they should have remained and helped to remove the cause of the malady. We have visited the premises where it has been most fatal, (in one block sixteen have died, as we are informed,) and the sources of the malaria are as plain as filthy, wet cellars, and abominable yards, sewers, and privies, can make them. The worst of plagues have been called into existence on board of ships; and pray, what but decaying vegetable and animal matter do ships ever contain to excite malignant fevers? The yellow fever, so fatal in southern cities, and the certain death to whites that spend a single night on some rice plantations, alike confirm the great truth of the organic origin of all pestilential diseases. If all the manure now wasted, and worse than wasted, in American and English cities, were properly deodorized, and applied to the land that needs it, how much sickness and suffering would be prevented! How many acres would produce three times more, for the benefit of all classes, than they now do!

To grow wheat and other crops on poor soils without manure, implies a prodigious waste of labor, for a part of which the consumers of crops in cities are taxed in enhanced prices; but in the end, both those that live in the country and such as dwell in cities, will be punished alike for the common wrong of impoverishing the earth. Producers and consumers must have a better knowledge of each other's wants and means; and instead of using the food of wheat plants to poison the denizens of cities, as is now witnessed in Rochester and Buffalo, all fecal matters must be carried back to the needy fields whence they were taken. From the city of Rochester go out into different sections of country, three canals, four or five railroads, and as many plankroads, for the cheap distribution of concentrated manure. With these advantages, why may not the average yield of wheat, within thirty miles of the city, be brought up to 33 bushels per acre? To achieve this result, and more than double the value of all the real estate in Rochester and Monroe county, requires but the application of a little common sense.

Condensed Correspondence.

AVERAGE PRODUCTION OF WOOL PER SHEEP, IN EACH OF THE STATES.—I have noticed recently, in several periodicals, an article taken from the census of 1850, giving the number of sheep and the amount of wool in each of the States and Territories in the Union. From these data I have added another column, giving the average weight of fleece in each of the States and Territories. If you will have the goodness to add still another column, giving, so far as you can conveniently, the medium price at which wool has been sold the present season in the several States, putting down Vermont at 37½ cents, and let the whole appear in your valuable paper, the *Farmer*, you will doubtless subserve the wool-growing interest, and very much oblige a constant reader. DANIEL GOOD YEAR.—Hinesburgh, Vt.

<i>States and Territories.</i>	<i>No. of Sheep.</i>	<i>Am't of Wool.</i>	<i>Weight of Fleece.</i>
Maine,	451,577	1,864,034	3 lbs. 0½ oz.,
New Hampshire,	384,756	1,108,476	2 " 14 " and a fraction.
Vermont,	919,992	3,410,993	3 " 11½ " nearly.
Massachusetts,	188,651	585,136	3 " 1 " and a fraction.
Rhode Island,	44,296	129,692	2 " 14½ " and a fraction.
Connecticut,	174,181	497,454	2 " 13¾ " nearly.
New York,	3,453,241	10,071,301	2 " 14¾ " nearly.
New Jersey,	160,488	375,396	2 " 5½ " and a fraction.
Pennsylvania,	1,822,357	4,481,570	2 " 7½ "
Delaware,	27,568	57,768	2 " 1½ " and a fraction.
Maryland,	177,302	480,226	2 " 11 " and a fraction.
District of Columbia,	150	525	8 " 8 "
Virginia,	1,310,004	2,860,765	2 " 3 " nearly.
North Carolina,	395,249	970,788	1 " 10 " and a fraction.
South Carolina,	285,551	487,233	1 " 11½ "
Georgia,	560,435	990,019	1 " 9½ " nearly.
Florida,	23,311	23,247	1 " 4 " nearly.
Alabama,	371,880	657,113	1 " 12½ " nearly.
Mississippi,	304,929	559,619	1 " 8 " and a fraction.
Louisiana,	110,338	199,897	1 " 13 " nearly.
Texas,	99,098	181,374	1 " 5 " and a fraction.
Arkansas,	91,256	182,535	2 " 4 " and a fraction.
Tennessee,	511,591	1,364,378	1 " 10¾ " and a fraction.
Kentucky,	1,102,121	2,297,463	2 " 1½ "
Ohio,	3,942,929	10,196,371	2 " 9¾ "
Michigan,	746,435	2,043,253	2 " 12 " nearly.
Indiana,	1,122,438	2,616,287	2 " 5½ " nearly.
Illinois,	894,043	2,150,113	2 " 6¾ " and a fraction.
Missouri,	756,309	1,615,560	2 " 2 " and a fraction.
Iowa,	149,960	373,898	2 " 8 " and a fraction.
Wisconsin,	124,892	253,968	2 " 0½ " nearly.
California,	17,574	5,520	2 " 5 " and a fraction.
Minnesota,	80	85	1 " 1 "
Oregon,	15,382	29,686	1 " 15 " nearly.
Utah,	3,262	9,222	2 " 13 " and a fraction.
New Mexico,	377,271	32,901	2 " 1½ " and a fraction.
	21,620,482	52,513,146	2 lbs. 7 oz., nearly.

We are sorry not to be able to comply with our correspondent's wish. It would be a somewhat difficult task to get the average price of wool in each of the States correctly, though could it be obtained it would, in conjunction with the column added in the above table, be exceedingly interesting. We presume Mr. GOODYEAR feels proud of his State, and wishes to contrast it with its sisters, for it appears at the head of the heap—yielding 3 lbs. 11½ oz. of wool to each sheep. Small as this weight appears, it is the highest average in the United States. The District of Columbia comes in second—averaging 3 lbs. 8 oz. There are but 150 sheep, however, and those probably in the possession of a few amateurs. Massachusetts is third—averaging 3 lbs. and 1 oz.; and Maine next—3 lbs. 0½ oz. Thus it appears that there are but three States in the Union that reach an average of three pounds of wool per sheep. Iowa, Ohio, Maryland, Michigan, Utah, Connecticut, New Hampshire, Rhode Island, and New York, range in the order named from 2 lbs. 8 oz. to 2 lbs. 14¼ oz. Arkansas, Wisconsin, Kentucky, Delaware, Missouri, Virginia, Indiana, New Jersey, Illinois, and Pennsylvania, range from 2 lbs. to 2 lbs. 7½ oz. Florida, Minnesota, Texas, Mississippi, Georgia, North Carolina, Tennessee, South Carolina, Alabama, Louisiana, Oregon, range from 1 lb. to 1 lb. 15 oz,

NEW VARIETIES OF WHEAT.—We have received from quite a number of esteemed correspondents, samples of the best kind of wheat raised in their different localities, and among them several new varieties. These we shall sow this fall, and shall be able to report another season. Some of the letters received we give below, which will be found interesting:

White Blue Stem.—As I am a friend of improvement, I will comply with your request in the December number of the twelfth volume of the *Farmer*, by sending you several heads of wheat. I am at a loss what variety to send, because I do not know what varieties you have, but I will send the best we have. The kind I send you we call the *White Blue Stem*. The first we had of it we cut in 1849, and it beats all the other kinds that we have. It generally looks poor in the fall and early in the spring; but after the weather gets warm, it outgrows all the other kinds for a while. It grows rather taller than most other kinds, but does not lodge soon. The straw is blue, if free from rust. The head looks slim, but it turns out well in threshing. The seed is full and white, if pure. The rust does not hurt it so soon as most other varieties. This year the grain does not look so bright as usual. The harvest has been later than usual, which we suppose is the reason of that. In a few cases there have been as high as forty and forty-five bushels to the acre raised in this valley. There is more of this wheat raised in this and the two adjoining townships, than of all the other varieties put together. I will also put some seed in the letter, so that if you have none, you can try it; and I wish you good success. CHRISTIAN L. HOLSINGER.—Bedford Co., Pa.

Australian Wheat.—Inclosed I send you a sample of the celebrated *Australian Wheat*. This is of my own raising, from seed that I had sent to me last fall from my native place, (Tetauket, Long Island.) I have about three acres, which, although sown nearly a month later than it should have been, (Sept. 30th,) will prove a fair crop. I intend to sow ten acres of it this fall, which I have reason to believe from what I have seen of it, will yield about thirty-five bushels per acre without any extra pains being taken with it. At least, I am confident that it will yield a third more per acre than any other kind of wheat now grown in the United States. I hope to be able to supply at least a part of those of my neighbors who are anxious to get the seed of it the coming year.

The wheat crop in this vicinity is very good this season, and is now nearly all harvested and secured, without a drop of rain. Other crops are somewhat retarded by drouth, but the rain to-day is reviving.

We have succeeded in raising some very beautiful flowers from those seeds you sent us. They attract the attention of passers by, who often inquire where we got the seed, to which we are always happy to answer, "They were presented us by the editors of the *Genesee Farmer*." D. D. TOOKER.—Napoleon, Mich.

Washington Wheat.—I herewith inclose you a sample of wheat, known here as the *Washington Wheat*, which agrees with the description of the *Australian Wheat* given in the *Genesee Farmer*. It has been very much admired by farmers in this neighborhood. We raised on one acre, accurately measured, and with nothing more than the ordinary barn-yard manure, forty-one and a half bushels of clean wheat, weighing sixty-two pounds to the bushel. Its flour-making properties were very much questioned; but if it is not left to stand till it becomes too ripe, and with a miller that understands his business, it will make as good bread as any other variety that is raised in this district. You will please, through the medium of your valuable paper, let us know whether it is the *Australian* or not. Some of the ears contain over a hundred grains; one reached 120. WM. W. PARKER. Parkersville, Chester Co., Pa.

I herewith inclose a sample of a variety of wheat that I obtained a few years ago from a man that moved from Columbiana county, Ohio, to this place at that time. It was from a crop grown on five acres of land, the entire yield of which he said was over two hundred bushels. The inclosed specimen is of the third crop raised since I procured the seed, sown the latter part of September, on spring wheat stubble land, and had but an indifferent chance. The marked phase of the variety appears to be tall, coarse straw, with long heads, well filled with small red grains. Yields well, weighs well, and makes very good flour.

This section of country is not considered capable of producing good crops of wheat, and therefore very little attention is paid to it. Cheese-making is the great business with farmers here; and the hundreds of tons sent out of the country is, in my opinion, exhausting those great elements of vege-

tation which we already need in greater abundance in order to produce good crops of wheat. EZRA HARRINGTON.—*Greene, Trumbull Co., Ohio.*

Herewith I send you three of the most approved varieties of wheat grown in this district. They are known here by the names of *Blue Stem*, *White Bearded*, and *Tennessee*.

The *Blue Stem* is rather late, but grows large, and is very productive. The straw is stiff and stands up well. As yet it is a sure crop, makes excellent flour, and commands the highest price of any variety known here.

The *White Bearded* is a rather early wheat of large growth, stands up well, and yields well. The grain is very sound and heavy, and makes excellent flour.

The *Tennessee* is a middling early wheat. Smooth, white chaff, rather weak straw. Not very productive, but makes excellent flour.

We have also the *Mediterranean*, *Golden Chaff*, *Red Chaff*, *Smooth* and *Velvet N. Y. Flint*, &c., but the three described are considered the best here. ROBERT FRAIZER.—*Danville, Ind.*

•••••

SOARING OATS WITH WHEAT.—A farmer residing in Grundy county, Illinois, having repeatedly tried the experiment of sowing oats with wheat as a protection from the severity of the winter, is fully satisfied that it will answer a good purpose. After his ground is prepared for the wheat, he first sows one bushel of oats per acre and then puts the usual quantity of wheat, and harrows them in together. He has this season three different pieces of wheat on the same ground, all prepared alike. On the first piece he sowed with the wheat one bushel of oats per acre; on the second, half a bushel; and on the third, no oats at all. The same kind and quantity of wheat was sown on each. The first piece is good, without any chaff. The second piece is a middling crop, with a little chaff. The third piece is nearly all chaff, and not worth harvesting.

A subscriber to the *Farmer* here has this season tried the experiment of sprinkling his onion beds with brine, made by adding salt to water till it would swim an egg, and then to one part of the brine put two parts of water. This mixture will kill all the grass without injuring the onion plants, thereby saving much labor. HENRY WATKINS.—*Reed's Grove, Ill.*

The fact stated by our correspondent is of much value, and the practice of sowing a few oats with winter wheat on soils on which it is apt to winter-kill, should be more generally adopted. The oats kill out in the winter, and afford protection and manure to the wheat plant.

The mixture of salt and water, though it might have answered to a charm in this particular instance, should be used with caution; for we are constantly informed of experiments with salt where the whole crop was destroyed.

•••••

SOAKING CORN IN A SOLUTION OF HARTSHORN.—Reading, in the April number of the *Farmer*, that soaking corn in a solution of hartshorn was attended with great benefit, I was induced to try it. I put two ounces of hartshorn to a peck of corn, and soaked it six hours, planting it immediately afterwards, and rolling it in plaster as I planted. I also planted corn in the same field, rolling it in plaster without soaking in the hartshorn; and there is no difference in the corn. I also read that salt on potatoes was good. I tried it, and it proved fatal. A SUBSCRIBER.—*Starke county, Ohio.*

At the time we received the above communication, Mr. BIGELOW, of Orleans county, N. Y., was in our office, and said that he and many farmers of that neighborhood had used the solution of hartshorn for corn, just as did our friend, *with the most beneficial results*—the corn soaked was at least a foot higher than that not soaked in the hartshorn, other things being equal.

It is known that ammonia, or hartshorn, has a very stimulating effect on corn, and indeed on all vegetables; but we can hardly see how it is possible that the small quantity which corn would imbibe by soaking in such a weak solution, could have a *fertilizing* effect on the plant. If it does any good, it must be in strengthening the germinating principle, and giving the plant a good start, so that it can afterwards better help itself. If any others of our readers have tried it, we should like to hear the result.

•••••

Horticultural Department.

CONDUCTED BY P. BARRY.

DEATH OF A. J. DOWNING.

By one of those terrible accidents that redden the pages of our daily history with human blood, this gifted and estimable man has been cut down, in the very prime of life, and in the morning of his influence and usefulness.

Of all the records of recklessness, this burning of the steamer *Henry Clay* will be recollected as one of the most painfully aggravated and inexcusable. That for the sake of a paltry strife, seventy or eighty human beings should be hurried into eternity, in broad day light, on the peaceful waters of the Hudson and within a rod of the land, is truly a most excruciating thought. If sympathy can afford any consolation to the mourning relatives of those who so suddenly perished, surely they have it. But what is sympathy? What can the world say or do, to assuage the grief of the lonely widows, the orphaned children, the desolate fathers, brothers, and sisters, whose loved ones have fallen victims to this sad disaster? Ah! very little indeed!

The loss of Mr. DOWNING is no common one. It is felt, by all who knew him and who appreciated his talents and labors, as a national calamity. As a contemporary has truly said, "There is no man whom the country could so ill afford to lose, or whose services can so little be replaced, as those of Mr. DOWNING." He was a man of shining talents and the most varied accomplishments. As a pomologist, his works are looked upon as the standard American authority, both at home and abroad. He was familiar with horticulture in all its branches, both in theory and practice. In landscape gardening and rural architecture he had no equal in this country. Besides, he was a polished scholar, and a graceful and effective writer. He had made himself thoroughly acquainted with the resources of the country, and the wants of the country people. Country life was his study: how its industry might be expanded and improved—how it might be refined and elevated—how its comforts and pleasures might be multiplied. How nature and art might best be united in beautifying the country home, and making it expressive of the social life, as it should be, of the American people, was his great theme—his great object. How devotedly and successfully he pursued it, is well known—the face of the country proclaims it. Its improved architecture, its orchards, and its gardens, everywhere speak of his teachings—of the knowledge and the taste he has disseminated, and the influence he has exerted upon the hearts and minds of his countrymen. But he is gone. His labors are ended. His life was a short one, but active and useful, and we trust prepared him for a glorious eternal paradise.

Reader, while we mingle our sorrows for the deceased, and our sympathies with his afflicted relations and friends, let us cherish his memory, and honor it by studying anew his writings and teachings, and carrying them into practice. His death is a solemn and impressive admonition that life is uncertain. But we must not despond nor be discouraged, but go forward manfully and perform the work allotted us, "while it is yet day."

Nearly all the Horticultural Societies in the country have passed resolutions of respect for the character of Mr. DOWNING and sympathy with his family, and the Massachusetts Society has invited the Hon. MARSHALL P. WILDER to deliver an eulogy on the life and character of the deceased. We are glad to learn this. The selection of Mr. WILDER is the best that could be made. No man is more competent to discharge this sad duty than he, not only because of a long and intimate friendship that has existed between him and the deceased, but because he is himself one of the most able and zealous

advocates of rural improvement in the United States, and every way competent to appreciate and pronounce upon the character of Mr. DOWNING and such services as he has rendered. We wish he could be persuaded to perform a like duty at Rochester. Western New York should be foremost in every mark of honor and respect to the character of Mr. DOWNING, for he was a native of our State. He always took pleasure in alluding to our natural advantages and our progress, and nowhere has his labors been of greater practical utility.

THE ROSE-COLORED WEIGELIA. (WEIGELIA ROSEA.)

THIS new and beautiful shrub, introduced from China, by Mr. FORTUNE, proves to be a most valuable acquisition. It proves perfectly hardy at Rochester, having stood the

past severe winter entirely unharmed, and bloomed profusely in the month of May. The plants were young, too, only one season's growth from cuttings. The flowers are in shape similar to the foxglove, of a beautiful deep rosy crimson, changing to a blush. The later and earlier expanded flowers produce a fine contrast, which is one of the charms of this elegant shrub worthy of note. It makes a pretty spreading bush, in foliage resembling a syringa. It is propagated easily from cuttings of the young wood, or from layers. Mr. HOVEY, in his Magazine, says that it has blossomed well in



his grounds, and that "small plants standing in a cold, damp locality, did not have so much as a single shoot injured." We recommend it in the smallest collections. The following is FORTUNE's account of its discovery :

"When I first discovered this beautiful plant it was growing in a Mandarin's garden, in the island of Chusan, and literally loaded with fine rose-colored flowers, which hung in graceful bunches from the axils of the leaves and the ends of the branches. The garden, which was an excellent specimen of the peculiar style so much admired by the Chinese in the north, was often visited by the officers of the regiment who were quartered at Tinghae, and was generally called the Grotto, on account of the pretty rock-work with which it was ornamented. Every one saw and admired the beautiful Weigelia, which was also a great favorite with the old gentleman to whom the place belonged. I immediately marked it as one of the finest plants of Northern China, and determined to send plants of it home in every ship until I should hear of its safe arrival."

EARLY SUMMER PEARS.

THE pear is really the most interesting fruit grown; and we are not at all surprised that those who devote much attention to its culture should in time become so deeply interested in it—so zealous and enthusiastic on the subject—as to appear, to the indifferent, who think that “a pear is only a pear,” quite beside themselves. It is one of the richest fruits we cultivate, and so varied in its form, size, coloring, texture, and perfume, that all tastes can be suited. The tree, too, is so beautiful in its growth, so varied in its habit, in its foliage, in the color of its bark, and in many minor particulars, that a dozen specimens of as many varieties furnish material enough for a delightful study. We are now so rich in varieties, that we can have pears ten months in the year—from the middle of July until the first of May. Up to the present time, (Aug. 10,) six varieties have ripened in our grounds, and it may be interesting to some and profitable to others to have a description and some account of them. They are not all first rate—perhaps not second rate—not more than two of them, perhaps, could be recommended for general culture, or to the proprietor of a small garden, in our locality at least; but in certain localities, or under certain circumstances, the worst of them might be valuable and well worthy of culture.

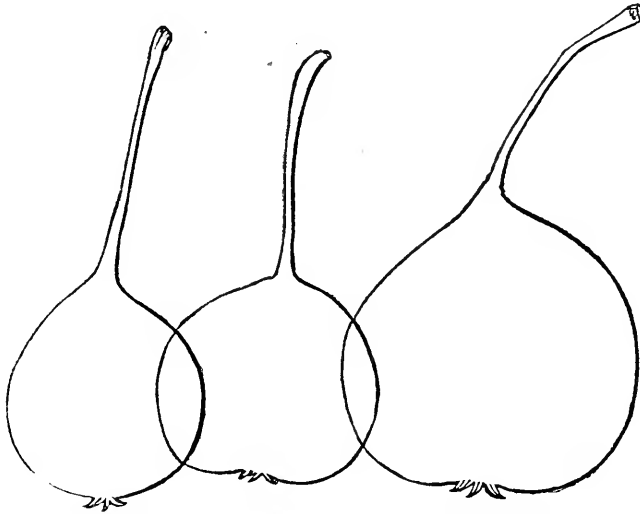

AMIRE JOANNET. LITTLE MUSK. MUSCAT ROBERT.

AMIRE JOANNET. (*St. John's, Early Sugar, &c.*)—Fruit small, varying from obovate to pyriform, regular, tapering to the stalk, which is long, straight and stiff, inserted without any cavity. *Calyx* open, large, not sunk. *Skin* greenish yellow, becoming lemon yellow at maturity. *Flesh* breaking, juicy, musky, and sweet. *Tree* upright, and of vigorous growth. *Young shoots* olive colored, with minute gray dots. *Leaves* large, roundish, flat, glossy, and rich, slightly toothed, and on very long and large petioles. *Tree* very productive, and succeeds well both on pear and quince stock. It is well worthy of a place in large gardens, not merely on account of its earliness, but because the tree is very beautiful, with its large, glistening foliage, and beautiful, bright, little, miniature pears. Ripens here from middle to last of July. This season it commenced to ripen on the 20th.

LITTLE MUSK. (*Little Muscat, Petit Muscat, Primitive, &c., &c.*)—There is scarcely

a day of difference here between the ripening of this and the preceding, and very little difference in the quality. *Fruit* small, about an inch in diameter, regular, turbinate or top-shaped, tapering to the stalk, which is an inch to an inch and a half long. *Calyx* large, open, in a very slight depression. *Skin* greenish yellow in the shade, streaked and mottled with dull red in the sun, and sprinkled with yellow dots. *Flesh* yellowish, breaking, sweet, and juicy, with a pleasant musky flavor. *Tree* is an upright, fine, pyramidal grower, moderately stout. *Young shoots* glossy, of a reddish brown, with gray dots. *Leaves* small, oval, folded. *Petioles* reddish, long, and slender. Productive—bears in profuse clusters. We have this season seen upwards of thirty pears, good specimens and all ripe, on a single branch exactly twelve inches long.

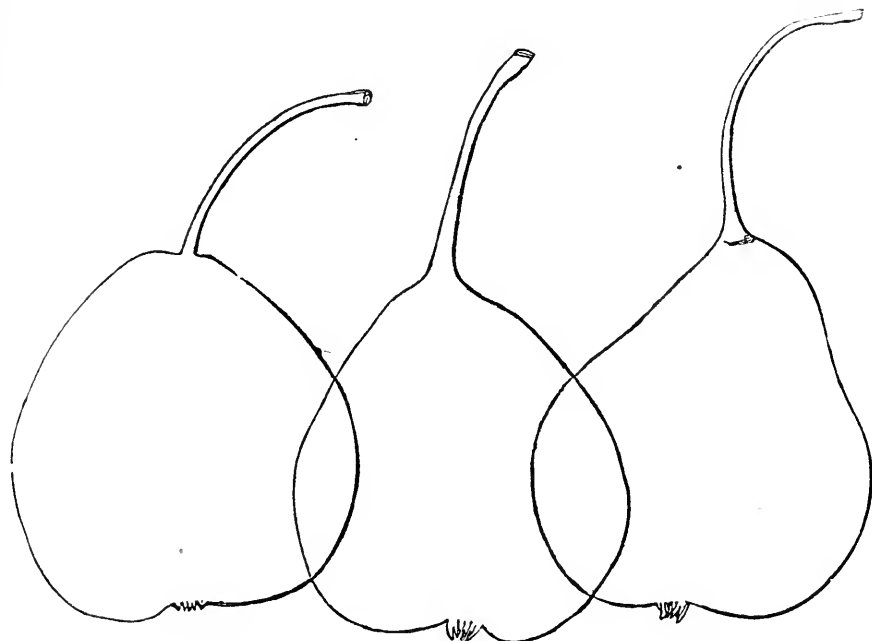

DOYENNE D'ETE.

MADELAINE.

SKINLESS.

MUSCAT ROBERT. (*Gros St. Jean, &c.*)—We described this pear in Volume 11, page 218, but bring it forward now to make up a small group that ripen within a short period. *Fruit* rather small, very regular, top-shaped, tapering to the base of the stalk, which is about one and a half inches long, and fleshy at the base. *Calyx* open, in a very slight depression. *Skin* greenish yellow, becoming a pale lemon yellow at maturity, and delicately marbled with red on the side next the sun. *Flesh* white, breaking, juicy, very sweet, musky, and pleasant. Ripe from 1st to 10th of August. The *tree* is remarkably distinct and very beautiful, erect and vigorous in growth, with yellowish wood, in winter quite golden. *Leaves* large, flat, glossy, and pale yellowish green. Very productive. Makes a beautiful pyramidal or dwarf tree on the quince.

DOYENNE D'ETE. (*Summer Doynenne.*)—We gave a full account and description of this excellent and beautiful variety at page 217 of last year's volume. We introduce it now, in this group, for the purpose of saying that no variety yet cultivated, and ripening at the same time, equals it. Beautiful, melting, juicy, and delicious. Ripens better on the tree than any other variety we know of, but is richer if picked a few days before maturity. The tree is vigorous and handsome, bearing regular and most abundant

crops. Ripe here this season on the 20th of July, and lasting till 10th of August. It is one of those varieties that succeed particularly well on the quince; but is so prolific, that unless pretty closely pruned every year, it will soon become enfeebled.

MADELAINE. (*Citron des Carmes.*)—This is one of the best known and most generally cultivated of all our early pears. *Fruit* medium size, quite uniform. *Stalk* varying from one to two inches long, moderately stout. *Calyx* small, closed, in a shallow, somewhat wrinkled basin. *Skin* pale greenish yellow, with a few small reddish dots on the sunny side. *Flesh* white, melting, juicy, sprightly and fine flavored. Ripens here from 1st to 10th of August. *Tree* a vigorous and rapid grower both on pear and quince. *Shoots* long, dark olive. *Leaves* large, glossy, dark, slightly waved on the edges. Bears young and abundantly. Like the *Doyenne d'Ete*, although possessing great natural vigor, it bears so profusely on the quince that it requires close pruning to sustain its vigor.

SKINLESS. (*Sanspeau.*)—*Fruit* medium size, pyriform, largest near the base, but slightly contracted at the eye. *Stalk* long and slender, with a fleshy projection at the base. *Calyx* closed, and set in a shallow, furrowed basin. *Skin* thin, smooth, greenish yellow; cheek brown, with reddish dots. *Flesh* half melting, sweet, delicate, and finely flavored. Does not last long. *Tree* an upright, free grower, with slender, reddish brown shoots, and flat, glossy, wavy leaves, on long, slender footstalks. Bears regular and abundant crops, and fruit always fair. Ripens here about 1st of August.

THE POMOLOGICAL CONVENTION.

ON the 13th of the present month, this body assembles in Philadelphia. This will be its fourth session. The first was held in New York, in 1848, and the second in 1849, in the same place. The third was held in Cincinnati, in 1850, and was comparatively a failure, owing to the nonattendance of eastern and northern delegates, and a local misunderstanding in regard to the preliminary arrangements for the accommodation of the Convention. Four years have thus elapsed since the organization of the institution, and we may reasonably expect to see brought forward during the approaching session, some of the results anticipated by its originators. Committees were appointed in all the fruit-growing States of the Union, to collect information on everything concerning fruits and fruit-culture in their respective localities, and to arrange the same in the form of reports, to be laid before the Convention. We trust these committees have not been idle, but are prepared to present such an array of useful facts and statistics, in regard to the great business of fruit growing, as has never before been collected in this country. The last four years have been a period of wonderful activity in this department of industry. Never before were so many fruit trees planted in so short a time in this country, nor certainly in any other. Never before were so many persons actively and zealously making inquiries and investigations on the subject—in testing varieties, modes of propagation and culture, soils and manures, and the various theories and practices suggested by writers, and by the active imaginations of the most energetic, original, and inventive cultivators in the world. With all this we can not but anticipate a rich and varied fund of information, that will aid in clearing up some matters that are yet imperfectly understood, and give a fresh and healthy impetus to the art of fruit culture.

One thing we must take the liberty of suggesting to the committees, and that is, to exclude from their reports all extraneous or irrelevant materials, all common-place or general facts, all discussion of settled points, or descriptions of well known objects. Give all the information in your power in regard to your own localities, and your own, actual, downright experience. State the facts as briefly as possible, without an array of

words to give it importance, but in fact robbing it of its value. What the people of Pennsylvania and Ohio and Maryland will wish to hear reported from Western New York, is that certain varieties succeed well and certain other varieties do not—that certain soils, modes of propagation and culture, give such and such results; and we in return, will expect similar information from them. We allude to this matter, because we know something of reports heretofore presented. We hope, too, that the same spirit will be manifested in the discussions. Whatever we may have occasion to say there, should be pointed and brief; for the time of a large body of working men, many of whom will be from a great distance, will be too valuable to be trifled with. The discussions at best are not so valuable or reliable as they might be; we look to the reports, carefully prepared and analyzed, as of much more importance.

One thing has always been very badly managed by these conventions, and that is the publication of their proceedings. The two New York meetings entrusted their transactions to the American Institute, and they were not permitted to see the light of day for full six months, and then not half the members were served with copies. The Cincinnati meeting did not manage much better. The proceedings were tardy in appearing, and were not remarkable for their accuracy when they did. With all this experience we do not doubt but that the Convention of 1852 will take such steps in the outstart as will secure a full, correct, and reliable report of all its proceedings published and placed in the hands of all its members without the least delay. Thus only will they be of any value, or awaken any interest in the community.

There will be, undoubtedly, a grand display of fruits. The later peaches of New Jersey and Delaware will be in perfection, and will be a most interesting item. The pears around Boston, we are glad to learn are unusually abundant and fine this season, and we anticipate in them a sight worth seeing. In Western New York our pear crop is perhaps the only thing in the way of fruits of which we can make any respectable show. We bespeak from all parts of the country a large attendance. Whatever good may otherwise result from it, that of making men, engaged in the same pursuit, acquainted with each other, and forming them as it were into a sort of brotherhood, will certainly not be least important.

The death of Mr. DOWNING, who was chairman of the General Fruit Committee, and one of the originators and master spirits of the organization, will throw its dark shadow over the meeting. Hundreds, like ourselves, but a week or two ago were in full expectation of meeting him there, of having the pleasure of his company, and of being instructed by the information he was collecting and preparing to impart. We understand that the Hon. MARSHALL P. WILDER will deliver the eulogy on Mr. DOWNING's life and character, before the Convention. It will be a most timely and appropriate proceeding.

THE CRESCENT SEEDLING STRAWBERRY.—A very remarkable variety of strawberry, bearing this name, and said to have been originated in New Orleans, is just now noticed in the papers, and one nurseryman advertises them at \$2 per plant. Our friend, R. G. PARDEE, Esq., of Palmyra, describes it in the Rural New Yorker, as producing "a constant and abundant supply of large, high flavored, conical, dark red strawberries, from January to August inclusive, at the end of which time the old plants die out, and a few runners strike with which to renew the bed." The *Picayune* says "it bears every day, (!) and is in much request all over the country, Mr. Lawrence having obtained them himself by a happy system of *grafting* (!) and *crossing*." Mr. PARDEE has not had this variety bear yet, nor has any one else in the north that we have heard of. We therefore advise people to keep cool until it has been well tested. The Alpine humbug has not yet been forgotten, and we very much apprehend that the "Crescent"

may disappoint expectation in the same way. It is not wonderful that in the climate of New Orleans any strawberry under good culture and management should bear from January to August. Growth is so rapid, that young runners get into a bearing state before the old ones are exhausted. Give us the climate of New Orleans, and we will produce *Hovey's Seedlings* and *Burr's New Pine*, and all the rest of them, seven months in the year; but it can not so well be done at the north.

RHUBARB.—We have received from Mr. B. P. CAHOON, of Kenosha, Wisconsin, two stalks of Rhubarb, each eighteen inches long, seven in circumference, and weighing together four pounds.

GENESEE VALLEY HORTICULTURAL SOCIETY.—DEATH OF A. J. DOWNING.—At a special meeting of the Horticultural Society of the Valley of the Genesee, held in the city of Rochester, Aug. 12, 1852, the President, on calling the meeting to order, stated that he had called the members together at the suggestion of others, and in accordance with his own feelings, to express in some suitable manner the feelings of the members in regard to the sudden and melancholy death of A. J. DOWNING, who had been for many years an honorary member of this Society.

The Secretary being absent, JAS. VICK, JR., was appointed Secretary pro tem.

On motion of M. G. WARNER, a committee of five were appointed to prepare resolutions for the consideration of the meeting.

The President appointed M. G. WARNER, JAMES H. WATTS, H. E. HOOKER, GEO. ELLWANGER, and A. FROST.

The committee, through their chairman, reported the following Preamble and Resolutions, which were unanimously adopted:

Whereas, In the death of A. J. DOWNING American Horticulture has lost its noble and gifted standard bearer; and society one of its most amiable, accomplished, and useful members—who has done more than any other to awaken among the American people an appreciation of their country's resources, and to cultivate and diffuse a love for the beautiful in nature and art—whose writings, brilliant and powerful in style, and truly American in sentiment, have given us a Horticultural Literature which commands the admiration of the world,—therefore,

Resolved, That we regard his loss as one of the greatest that could in this day befall the American people in the death of any one man—that we deeply sympathize with his afflicted friends and relatives, truly "mourning with those who mourn" for the loved and lost.

Resolved, That though Mr. DOWNING is no more, and his voice is hushed in death, yet he still speaketh—his works will live after him, and his influence be felt while correct taste has a disciple or a home in the earth.

Resolved, That we recommend the Horticultural Societies of this country to take some united action to testify in a suitable manner their regard for the memory of Mr. DOWNING; and that a committee of three be appointed, to correspond with other Societies on the subject.

P. BARRY, I. WETHERELL, and JAMES H. WATTS, were appointed a committee in accordance with the resolution.

Resolved, That the proceedings of this meeting be furnished the various horticultural papers, with a request to publish the same, and a copy thereof be forwarded by the President of the Society to the family of the deceased.

The following delegates were appointed to attend the Pomological Congress to meet in Philadelphia on the 13th of September:

J. J. THOMAS,	JAMES VICK, JR.,	R. G. PARDEE,	GEO. CHERRY,
P. BARRY,	JAMES H. WATTS,	JOSEPH FROST,	GEO. ELLWANGER,
A. FROST,	ZERA BURR,	H. E. HOOKER,	H. P. NORTON.

In consequence of the meeting of the Pomological Congress in Philadelphia, on the 13th of September, the exhibition of the Genesee Valley Society was postponed until the 24th and 25th of September.

JAMES VICK, JR., *Secretary*.

P. BARRY, *President*.

Ladies' Department.



MALOPE GRANDIFLOEA.

FOREST FLOWERS.

BY THE AUTHORESS OF "THE BACK-WOODS OF CANADA."

WHILE you recommend to the attention of the daughters of your subscribers the cultivation of the flowers of the green-house and parterre, be pleased to speak a few words in behalf of the natives of the soil—I mean the lovely Wild Flowers—both as regards their cultivation and delineation on paper. I am a great admirer of the indigenous flowers of the forest, and it is with a feeling strongly allied to regret, that I see them fading away from the face of the earth. Many families, containing blossoms of the greatest beauty and fragrance are fast disappearing before the destructive agency of the chopper's axe, fire, and the plow. They flee from the face of man and are lost, like the aborigines of the country, and the place that knew them once, now knows them no more. I look for the lovely children of the forest, those flowers that first attracted my attention, but they have passed away, and I seek them in vain—another race of plants has filled their place. Man has altered the face of the soil—the mighty giants of the forest are gone, and the lowly shrub, the lovely flower, the ferns and mosses, that flourished beneath their shade, have departed with them. The ripening fields of grain, the stately plantations of Indian corn, with the coarser herbage of the potato and turnep, grasses and clover, have usurped their places—a new race of wild plants, suited to the new condition of the soil springs up, to dispute the possession of the ground with the foreign usurper. Where now are the lillies of the woods, the lovely and fragrant *Pyrolas*, the Blood-root, the delicate sweet scented *Mitchella repens*, the spotless *Monotropa*, with *Orchis* of many colors, and a thousand other lovely flowers? Not on the newly cleared ground, where the forest once stood, may we now hope to find them; we must re-enter the woods, their forest home—they die exposed to the fierce glare of the Canadian summer sun.

I cannot help regretting that none of our Botanical Societies have made any effort to preserve correct representations of these rare but evanescent beauties of the woods, by encouraging to any extent the pursuit of *botanical* flower painting among the amateur artists of the Colony. *PURSH* has given a few in his *Flora*, *BURTON* has many more, but still there are a vast number that find no place in any published work. Neither has there been sufficient attention paid to the correct delineation of form, or exact shade of color, to make them as attractive as they might be, and thereby increasing their value.

Now, Mr. Editor, there are doubtless many young and accomplished females who have been transplanted to America—many, too, among the natives of the U. S. and British America who would be glad to exercise this delightful talent amid the solitudes of the back woods, stimulated by the hope of acquiring fame, or a remuneration for time so employed. How valuable could a Canadian *Flora*, thus illustrated be made, provided that the subjects were faithfully delineated, with close attention to botanical structure, form and color. Have we any Canadian *Flora* devoted entirely to the vegetable productions of Upper and Lower Canada?

If I have trespassed too long upon your valuable time, pray forgive. If you think it would prove acceptable to your readers, (the ladies I assure you sometimes read the *Genesee Farmer* as well as their husbands and brothers,) I will from time to time send you a few scraps from my "Forest Gleanings"—about wild flowers and other matters connected with Canadian Natural History.—*Oaklands, Rice Lake Plains, C. W.*

Send us the promised Scraps from your "Forest Gleanings," by all means.—Ed.

MALOPE GRANDIFLORA.—This flower, a correct drawing of which we give on the preceding page, is one of the finest annuals that now beautify our garden. It belongs to the mallow family, several members of which are to be found in our fields and on the road-side. We shall preserve the seed for the benefit of the lovers of fine flowers.

Editor's Table.

AGRICULTURAL FAIRS.—Below we publish all the agricultural fairs to be held this fall that have come to our knowledge.

STATE FAIRS.	
New York, at Utica,.....	Sept. 7, 8, 9, 10
Ohio, at Cleveland,.....	" 15, 16, 17
Michigan, at Detroit,.....	" 22, 23, 24
Canada West, at Toronto,.....	" 21, 22, 23, 24
Vermont, at Rutland,.....	" 1, 2, 3
Pennsylvania, at Lancaster,.....	Oct. 20, 21, 22
New Hampshire, at Meredith Bridge,.....	" 6, 7, 8
Indiana, at Indianapolis,.....	" 19, 20, 21
New Brunswick, at Frederikton,.....	" 5 to 9
Wisconsin, at Milwaukee,.....	" 6, 7, 8
Georgia,.....	" 18 to 23
Maryland, at Baltimore,.....	" 26, 27, 28, 29
American Pomological Congress, at Philadelphia,.....	" 13
American Institute, at New York,.....	" 5
" " Exh.b. of Stock,.....	" 19, 20, 21
Rhode Island Society of Improvement, at Providence,.....	Sept. 15, 16, 17
New England Society for Improvement of Poultry, at Boston,.....	" 7, 8, 9, 10
COUNTY FAIRS.	
Saratoga, at Mechanicsville,.....	Sept. 15, 16, 17
Rensselaer, at Troy,.....	" 22, 23, 24
Clinton, at Keeseville,.....	" 22, 23, 24
Essex,.....	" 20, 21, 22
Suffolk, at Huntington,.....	" 22
Osageo, at Morris,.....	" 22, 23
Jefferson, at Watertown,.....	" 16, 17
Cordland,.....	" 15, 16
Greene, at Cairo,.....	" 21, 22
Columbia, at Chatham 4 Corners,.....	" 29, 30
Madison,.....	" 22, 23
Wayne, at Wolcott,.....	" 21, 22
" do, at Palmyra,.....	" 25, 29
Rensselaer, at Troy,.....	" 22, 23, 24
Herkimer, at Herkimer,.....	" 28, 29
Ontario, at Canandigua,.....	" 29, 30
Monroe, at Rochester,.....	" 29, 30
Wyoming, at Warsaw,.....	" 22, 23
Orange, at Middletown,.....	" 29, 30
Oswego, at Fulton,.....	" 29, 30
Onondaga, at Syracuse,.....	" 22, 23
Chemung, at Horse Heads,.....	" 29, 30
Chenango, at Norwich,.....	" 29, 30
Orleans, at Albion,.....	" 28, 24
St. Lawrence, at Canton,.....	" 15, 16
Seneca, at Waterloo,.....	" 30, 31
Genesee,.....	Oct. 6, 7
Cayuga, at Auburn,.....	" 6, 7
Putnam, at Carmel,.....	" 5, 6
Richmond,.....	" 17
Dutchess, at Washington Hollow,.....	" 5, 6
Westchester, at White Plains,.....	" 6, 7, 8
TOWN FAIRS.	
East Bloomfield,.....	Sept. 22
Brookfield, Madison county,.....	" 29, 30
Cape Vincent, Jefferson county,.....	" 15
Bristol, Ontario Co., at Bristol Center,.....	" 16

FINE CUCUMBERS.—Some friend sent us in the spring four cucumber seeds, which were represented as being very fine, only one of which grew. On this vine we now have a fine show, the cucumbers when fit to pick averaging fourteen inches in length and nine in circumference. They appear to be very similar to a variety we have seen in England, but of which we had not been able to procure seed.

NEW YORK STATE FAIR.—The State Fair for the present year will be held at Utica, on the 7th, 8th, 9th and 10th of September. Persons may become members of the society by the payment of \$1, which will admit himself and family to the exhibition during the continuance of the show. Single tickets, admitting one person, once, 12½ cents. Members of the society will be admitted to the grounds on Wednesday, the 8th, and on Thursday the grounds will be open to the public, and continue open two days.

Exhibitors must become members of the society, and have their articles and animals entered on the Secretary's books on or before Monday, the 6th September, and all articles and animals, except horses, must be brought into the enclosure as early as Tuesday noon, in order that they may be suitably arranged. Horses will be received early Wednesday morning, but must be entered previously. The Secretary desires all entries forwarded to him previous to the 4th of September, that he may be able to print a full Catalogue previous to the Exhibition.

Forage and water will be furnished for stock free of charge, and grain for pigs and poultry.

Persons desiring accommodations for stock will have provision made on application to JOHN BUTTERFIELD, of Utica. Mr. B. will also take charge of all articles directed to his care, and provide for their delivery at the Show Ground, if notice is given and provision made for the expenses.

A QUICK AND PLEASANT TRIP.—On the morning of the 19th ult., we left home at 6 o'clock in the morning, took a seat in the cars of the Niagara Falls Rail Road at half past six, and a few minutes after seven found ourselves very pleasantly located at the breakfast-table of our friend, H. P. NORTON, of Brockport—enjoyed a very pleasant visit with Mr. N. and his amiable and intelligent wife, examined his fine garden, admired the beautiful flowers and well kept trees, feasted on his delicious summer pears, looked at Mrs. N.'s excellent currant wine, (only looked of course)—visited the model peach and pear orchards of AUSTIN PINNEY, of Clarkson, to see which are well worth a trip to Clarkson, and returned and wrote this article, before half past ten; thus having crowded about forty miles of travel and a week's enjoyment into four hours. We live very fast in these railroad times.

☞ In the *Horticulturist* for August we find the leading article on the destruction of the Ailanthus, on account of its real and supposed bad qualities. It is the last number issued before Mr. Downing's death, and this was perhaps the last article written by him, and has been read by his friends with a peculiar and mournful interest. In it we find the following remarkable paragraph, which with a little superstition we may imagine to be prophetic of his own untimely end:

"We may take the opportunity to preach a funeral sermon over his remains that shall not, like so many funeral sermons, be a bath of oblivion-salters to wash out all memory of his vices. For if the Tartar is not laid violent hands upon, and kept under close watch, even after the spirit has gone out of the old trunk, and the coroner is satisfied that he has come to a violent end—lo we shall have him upon us tenfold in the shape of suckers innumerable."

OREGON.—Oregon is destined to become one of the greatest States of this Union. We think there is more intelligence and public spirit in Oregon, in proportion to the population, than in any other State or Territory. We receive orders for books and papers by almost every arrival, in exchange for which we have had some of the product of the territory—several interesting little bags of gold dust. We have over fifty subscribers at Salem, Marion Co., and large clubs at Lexington, Rainer, Oregon City, and other offices. Large numbers of fruit trees have been sent out from the Rochester Nurseries. Success to the farmers of the Pacific.

MULTICAUL RYE.—Those who have inquired for the Multicaul Rye are referred to the advertisement of Mr. BIGELOW. Having procured some for the purpose, we will furnish our distant friends who may apply with small quantities through the mail.

ADVERTISEMENTS, to secure insertion in the Farmer, must be received as early as the 10th of the previous month, and be of such a character as to be of interest to farmers. We publish no other. Terms—\$2.00 for every hundred words, each insertion, paid in advance.

Inquiries and Answers.

GROUND MOLES.—I noticed in the July number of the *Farmer* an inquiry respecting the best method of destroying moles. The mole is a great scourge at the west, and annually destroys vast quantities of corn, and no remedy I have ever tried is entirely effectual. The plan that is adopted by many farmers, is to dissolve arsenic and soak corn in the solution, and drop it in the hill; but this is not always effectual. Another plan is to run a furrow between the rows. But I go patiently to work and stamp down all the roads,

and watch them; and if a person is still, they will soon commence digging, when it is an easy job to catch them. The best time for this is in the morning, at noon, and at evening, and directly after a shower. I have often caught three or four in a day, without losing much time. If farmers would give a small reward for every mole caught on their premises, I think it would be an excellent way of getting rid of them. I know of some who have adopted this plan with complete success. J. W. LEWIS.—*Huntsville, Ind.*

There is much difference of opinion as to whether moles do harm or good. We are inclined to think that they do both. That they destroy a great many insects and grubs which are injurious to the crops, is certain; while at the same time they injure the plants by biting off the roots, &c., in making their interminable network of burrows. We have supposed they did not trouble our farmers so much as our correspondents state. There can be no doubt that they may be easily destroyed, if it is desirable. A trap could be made and placed in their burrows, which they traverse very frequently, rarely appearing on the surface. Or they may be poisoned by placing some worms in a vessel with carbonate of barytes, or arsenic, and letting them remain a few hours, afterwards placing a few of them in the burrows, and giving a fresh supply as soon as taken away. This plan has been often tried, and effectually destroys them.

THE WHEAT WEEVIL.—Our wheat the present season has been injured by an insect. On examining the heads of wheat affected, a number of small maggots of a yellow color will be found preying on the grain, and in some heads it will be nearly all destroyed. Most of our farmers call this the weevil, but some say it is the effects of the Hessian fly. Can you give us any light? G. S.—*Canandaigua, N. Y.*

While attending the trial of Reapers at Geneva, we noticed that the wheat upon which the reapers were testing their powers was very much injured by the wheat fly, and as it became a matter of conversation among the many their congregated, we noticed that it was generally attributed to the weevil. As our correspondent requests, we will endeavor to throw a little light on the subject.

The *Wheat Weevil* is a beetle, and does its mischief in the granary. The female deposits her eggs upon wheat in granaries, and the young larvæ immediately burrows into the grain, of which it eats the interior. It is sometimes very abundant in old granaries. Perhaps the best way to destroy them is to starve them out by putting no wheat in the place infested by them for one season, and in the mean time make extraordinary exertions to ferret them out by cleaning, whitewashing, &c.

FRUIT AND ORNAMENTAL TREES.

ELLWANGER & BARRY desire to call the attention of nurserymen, dealers, and planters, to the immense stock of trees now on their grounds, embracing Fruit Trees of every description, viz:

STANDARD APPLES, PEARS, PLUMS, CHERRIES, PEACHES, &c., on free stocks, for orchards, vigorous and well formed.

DWARF AND PYRAMIDAL PEAR TREES, on quince stocks. About 100,000, embracing every fine variety that can be so worked, two year old trees, low branched, vigorous and beautiful.

DWARF AND PYRAMIDAL CHERRIES, on Mahaleb stocks. Fine one, two, and three years old trees, well branched and finely formed.

DWARF APPLE TREES, on Paradise and Doucain stocks. Beautiful two year old trees, with heads, for immediate bearing—besides vigorous yearlings.

GOOSEBERRIES.—Large Lancashire sorts. Strong plants for immediate bearing.

CURRENTS.—Including the *Cherry, Victoria, White Grape*, and many other new and fine sorts. See our catalogue.

RASPBERRIES.—The new *Large fruited Monthly, Pastoff*, &c., &c. A complete collection of all desirable varieties.

GRAPES.—Hardy, native sorts—*Isabella, Catawba, Clinton*, &c.—strong two and three year old vines. Thirty varieties of Foreign Grapes, for vineries—strong, thrifty plants, in pots.

STRAWBERRIES of all desirable varieties, and all other fruits cultivated.

RUBIARIES.—Genuine *Myrtle's Victoria, Myrtle's Linus, Mitchell's Royal Albert, Downing's Colossal*, and hybrids of the above, of our own raising from seed, quite equal to any of them.

The entire fruit department is under our own personal supervision. The best quality of stocks is used, and the most scrupulous attention given to ensure accuracy. We flatter ourselves that no nursery collection can offer a stronger guarantee to purchasers, in this respect. The stock is all grown on new, fresh soil, and is healthy, well matured, and hardy. We ask purchasers to examine it.

ORNAMENTAL.—Large trees, for streets, parks, &c., such as *Horse Chestnuts, Silver Maples, Sugar Maples, Snowy Aboles, Mountain Ash, Elms, and Tulip Trees*, in large quantities, cheap.

RARE ORNAMENTAL LAWN TREES—embracing the most novel, remarkable, and beautiful trees and shrubs, both deciduous and evergreen, that can be grown in our climate. For particulars we must refer to the descriptive catalogue.

ROSES.—One of the richest collections in the country, including the newest and best European varieties, selected by us in person, last summer.

BULBIOUS ROOTS—imported annually from Holland.

DAHLIAS.—The new English and French prize sorts of 1851, besides fine older ones.

All articles packed in the best manner, and forwarded to any part of the United States, Canada, or California.

Orders strictly complied with in every particular.

The following catalogues are sent gratis to all who apply and enclose stamps to cover postage, which must be prepaid:

- No. 1. A Descriptive Catalogue of Fruits.
- No. 2. A Descriptive Catalogue of Ornamental Trees, Shrubs, &c.
- No. 3. A Catalogue of Dahlias, Fuchsias, Chrysanthemums, and bedding plants.
- No. 4. A Wholesale Catalogue, for nurserymen and others who wish to purchase largely.

Postage on Nos. 1 and 2—500 miles or under, 3 cts.; 500 to 1500 miles, 6 cts. Postage on Nos. 3 and 4—500 miles or under, 1 cent; 500 to 1500 miles, 2 cts.

Mount Hope Nurseries, Rochester, N. Y., Sept. 1852.

Fruit Trees and Seedling Stocks for Sale.

20,000 one year old Cherry stocks. Fine and strong.
15,000 do. Plum do. do. do.
with a few thousand two year old Apple, Plum, and Cherry seedlings.

Also, a general assortment of Apple, Pear, Plum, Cherry, and Peach trees. The stock of Apple trees is particularly fine, and embraces all the leading varieties, such as Baldwin, Rhode Island Greening, Newtown Pippin, Esopus Spitzenburgh, Northern Spy, and others in large quantities.

Terms as reasonable as at any other establishment, and trees delivered at the steamboat landing at Hudson, or at the depot of Hudson River or Hudson and Berkshire railroad.

E. G. STUDLEY,
Claverack, Col. Co., N. Y.—9-11*

SYRACUSE NURSERIES.

THORP, SMITH, HANCHETT, & CO., PROPRIETORS.
SYRACUSE, N. Y.

OUR nursery grounds, among the largest and most extensive in the country, are now covered with a most beautiful stock of Fruit and Ornamental Trees, Shrubbery, Roses, Green-house Plants, &c. We therefore invite particular attention to our stock of trees, which can not be excelled in size, thriftiness, and beauty, by those of any other establishment in the Union. Nurserymen, Amateurs, Orchardists, and Venders, are earnestly invited to call, examine, and judge for themselves.

APPLES.—We have a very extensive assortment of all the very best varieties in cultivation, both Dwarf and Standard.

PEARS.—Our stock of Standards and Dwarfs is much better than heretofore; and we invite competition, as none finer can be produced. We have also a few dwarfs five years old, filled with fruit spurs, and which have borne freely the past two years. (and now with a full crop,) that we will supply to those persons desiring fine fruit-bearing trees.

CHERRIES.—Both Standard and Dwarf, of all the newest and finest sorts, which can not be excelled for beauty and thriftiness.

PLUMS, PEACHES, APRICOTS, NECTARINES, CURRENTS, (including the *Victoria and Cherry*.) and ENGLISH GOOSEBERRIES, of all the best leading sorts.

OUR ORNAMENTAL TREES are of fine form and luxuriant growth, and require only to be seen to be admired.

EVERGREENS.—A fine assortment of *Norway and Balsam Firs, Spruces, &c.*

PEONIES.—A splendid assortment of both tree and herbaceous varieties.

DAHLIAS.—Over 150 choice selected kinds, at 25 cents for whole roots.

ROSES.—One of the largest stocks in the country, of all the leading varieties, being about 10,000 plants.

BULBIOUS ROOTS.—A splendid assortment, just imported from Holland, of best double *Hyacinths, Tulips, Crocuses, &c., &c.*

GREEN-HOUSE PLANTS.—A large collection of the choicest and newest kinds, including the new *Heliotropes Royaux, &c., Lantana Evangii, Moyas, Imperialis, Bella, Bicoloriana, &c.*

FUCSIAS in 50 varieties, including *Spectabilis, Eliza Millie, Sir John Pastoff, Serratifolia, Prince of Orange, Carolina, Pearl of England, &c.*

CHRYSANTHEMUMS.—A full assortment of all the best standard kinds in the country. Of the *New Dwarf and Daisy* varieties we have everything new and rare, including 30 of the very best sorts.

VERENAS.—A splendid collection of 50 varieties, including *Morey's New Seedlings*.

STRAWBERRIES.—All the best varieties, including the 3 new Cincinnati sorts, one of which took the \$100 premium.

HEDGE PLANTS.—*Buck Thorn, Privet, Red Cedar, and Osage Orange.*

SEEDLING STOCKS.—Nurserymen and others can be supplied with Apple, Pear, French Quince, Mahaleb, Doucain, and Paradise stocks, by giving us notice in due time.

Our Catalogues, with full descriptions and prices, will be forwarded to every post-paid applicant enclosing one letter stamp, if under 500 miles, and three stamps if over that distance.—9-21.

FRUIT & ORNAMENTAL TREES.

RIVER BANK NURSERY, ROCHESTER, N. Y.

SHEPARD & CHERRY, PROPRIETORS.

NOW offer to furnish nursery stock generally, of as good quality, and at as low rates, as can be obtained elsewhere.

Fruits of all the leading varieties, both standard and dwarf, of Apples, Cherry, Peach, Pear, Plum, &c., &c. Gooseberries, Currants, Raspberries, Strawberries, &c. Grapes—*Isabella, Catawba, Clinton, &c.*

Also 100,000 apple stocks, for root grafting. 20,000 Cherry stocks, root pruned.

All orders accompanied with cash or satisfactory reference, and all letters of inquiry post-paid, will receive prompt attention.

From the connection of Mr. Sheppard for a number of years with the following establishments, all of which sustain the highest reputation, viz: A. J. Downing and A. Saul, Newburgh, N. Y.; Wm. Reid, Elizabethtown, N. J.; and Ellwanger & Barry, Rochester, N. Y.; the proprietors flatter themselves that their knowledge of the great variety of tastes and wants of planters generally, will enable them to guarantee ample satisfaction to all favoring them with their patronage.

[9-21.]

C. J. RYAN & CO.,
 PROPRIETORS OF THE ROCHESTER AND CHAR-
 LOTTE PLANK-ROAD NURSERIES,
 Rochester, N. Y.,

OFFER for sale, as follows, at moderate prices:
 10,000 Apple trees, from five to eight feet high, four years
 old. All the principal early and late sorts. Also,
 Pear, Peach, Plum, and Cherry trees—all thrifty
 and in good order for transplanting.

20,000 Raspberries, including all the popular market vari-
 eties.

5,000 Isabella Grape vines, three years old, propagated
 from cuttings, not from layers—will bear fruit at
 once.

1,500 Apricot trees—large and thrifty—full of fruit buds.
 50,000 Cherry seedlings, (Black Mazzard), in fine order.
 They will all bud next year.

25 distinct varieties of Strawberries, among them the
 principal productive and high flavored sorts.

10,000 Rhubarb Roots. Downing's Colossal, Giant, and
 Myatt's Victoria.

100,000 Giant Asparagus roots, two and three years old.—
 Every family ought to have a bed of this delicious
 vegetable of the easiest culture.

Sea Kale and Horse Radish.

Hedge Plants, such as Privet, Osage Orange, and Buck-
 thorn, one and two years old.

Our Ornamental trees are straight and handsome. All
 the most desirable varieties under cultivation.

Shrubs, Running and Shrubby Roses, Ornamental Vines,
 &c., &c., cultivated largely, and will be sold low.

Our nursery land is principally a mellow, sandy loam,
 which furnishes our trees with buds of fibres, and
 gives them a decided advantage over trees cultivated in
 stiff clay or wet land, which generally produces long, bare
 roots, without fibres.

All orders addressed to us, as above, will be promptly
 attended to.

See our General Descriptive and Annual Catalogues,
 which will be sent gratis to all post paid applicants.

The extensive pear, peach, cherry, and apple or-
 chards connected with these nurseries, give them facilities
 which are seldom equalled in the propagation of nursery
 stock. All our scions and buds are cut from bearing trees;
 and if there is a possibility of having fruit trees accurate to
 name and description, we have every facility for doing so.
 September, 1852.—9-21.

Prices of Manures.

Peruvian Guano, 2½ to 2½ cts. per lb.
 Improved Superphosphate of Lime, (Mapes,) 2½ cts. per
 pound.

Superphosphate of Lime, (Extra No. 1, Duburgh's,) 2½
 cts. per lb.

Bone dust, when taken in equal quantities, \$2.25 per bbl.

Bone sawings, separately, \$2.50 per bbl.

Wood's Renovating Salts, 1 cent per lb.

Sugar-House Bone Black, \$3 per hhd.

Potash, 3½ to 4 cts. per lb.

Charcoal, pulverized, \$1 per bbl.

Sulphuric acid, 2½ to 2½ cts. per lb.

Plaster of Paris, \$1 to \$1.25 per bbl.

For sale at the State Agricultural Warehouse, No. 25
 Cliff street, New York. LONGETT & GRIFFING.
 September, 1852.—9-21.

Field Seeds.

AUSTRALIAN WHEAT—very superior. The berry of
 this grain is extra large, and makes the best of flour. It
 produces a greater average crop than any other variety now
 grown in New York. Several years' experience in its cul-
 tivation, proves that it is less liable to rust or mildew than
 other kinds; and as the stalk is large and strong, it is also
 less liable to blow down or lodge. Price, \$1 per bushel.
 Other varieties of wheat, such as the White Flint, Mediter-
 ranean, Black Sea, &c.

BROCKWHEAT, of the best kinds in market.

BETA DAGA, or Swedish Turnep Seed. The Purple Top
 and other superior varieties.

TURKEY SEED—Large White Flat, Long White, Red Top
 Flat, Yellow Aberdeen, Yellow Stone, and other improved
 kinds for the field or garden. A. B. ALLEN & CO.,
 June, 1852.—6-11. 159 & 191 Water st., New York.

**Northern N. Y. Live Stock Insurance Compa-
 ny,** Plattsburgh, N. Y. For terms, please apply to agents
 of the Company.

Fruit Trees, Seedlings, &c.

T. C. MAXWELL, & CO.,
 GENEVA, N. Y.

ENCOURAGED by the generous patronage heretofore
 received, and by a soil, climate, and position peculiarly
 favorable to the growth of healthy trees, we have so en-
 larged our stock of nursery articles that we are now enabled
 to offer great inducements to all who may wish to purchase
 either at wholesale or retail. We have between five and
 eight hundred thousand trees in the different stages of
 growth, which have been propagated with the strictest care
 as to merit and genuineness of varieties.

Orders by mail, or otherwise, promptly attended to, and
 trees securely packed and delivered at the railroad depot
 or steamboat.

Of large trees we offer, this fall, the following, viz:

60,000 Apple trees. Best varieties for market or family or-
 chards.

30,000 Cherry trees. Very thrifty and handsome.

6,000 Pear trees. Standards. Healthy and large.

20,000 do. Dwarfs, on true Angers Quince, one
 and two years old.

10,000 Peach trees. Very nice.

4,000 Plum trees. Five to seven feet high—best sorts.

2,000 Apricot trees. Mostly Dubois' Early Golden.

2,000 Grape vines. Mostly Isabella.

10,000 Evergreens. Balsam Fir, Cedars, Norway Spruce,
 &c., &c.

5,000 Mountain Ash. Large and fine. Very cheap.

3,000 Horse Chestnut. Large and handsome.

40,000 Cherry seedlings. Very nice.

20,000 Apple do. Two years old.

25,000 Buckthorn seedlings. Very nice for hedges.

Also, Hybrid Perpetual Climbing, and Moss Roses,
 Shrubs, Gooseberries, Currants, Raspberries, Strawberries,
 &c., &c.

Particular attention is called to our large stock of the
 following fruits, viz:

APPLES.—Wagener, Tompkins Co. King, Northern Spy,
 Primate.

PEARS.—Vergalieu, Bartlett, Louise Bonne de Jersey,
 Glout Moreau.

CHERRIES.—Great Bigarreau, Black Tartarian, Bauman's
 May, Early Purple Guigne.

APRICOTS.—Dubois' Early Golden, Moorpark.

GENEVA, SEPT. 1852. T. C. MAXWELL & CO.

**The best Railroad Horse Power, Thresher,
 AND SEPARATOR** (or riddle) in use, is made and sold
 by the subscribers, at Central Bridge, Schoharie Co., N. Y.
 We have made some valuable improvements this season,
 (for which a patent has been applied for,) which makes it
 superior to anything of the kind in use, as was fully estab-
 lished at the late trial of agricultural implements at Geneva,
 where it was placed in competition with several others,
 among which was Emery & Co.'s of Albany. We threshed
 at that trial more than one-half as fast with two horses, as
 was done with the best eight-horse lever power there.

Our price, delivered at the canal or railroad, is, for Horse
 Power and Machine, \$150 three months without interest, or
 \$130 cash.

These machines are warranted to suit the purchaser, or
 he can return the machine and have his money (if paid)
 refunded.

They are for sale by J. Rapalie & Co., Rochester, and by
 J. S. & W. C. Prouty, Geneva, N. Y.

Sept., 1852.—9-11* G. WESTINGHOUSE & CO.

French Zinc Paint.

THIS new and beautiful article of Paint is now offered to
 the trade and public, ground in prepared linseed oil, for the
 first time in this country. It has been used successfully in
 France for the last five years, where it has superseded white
 Lead as a paint.

The French Zinc when properly prepared and used,
 makes the most brilliant and durable white in use, and is
 entirely free from all poisonous qualities.

The French Zinc is not more expensive than white lead,
 and is prepared in such a manner that it requires no far-
 ther preparation for use, than to thin it with Turpentine or
 raw Oil to the consistency of white lead paint.

The French Zinc is very much whiter, and has a better
 body, than the New Jersey Zinc.

The French Zinc is offered dry, and prepared as above,
 in quantities to suit purchasers, at the Manufacturer's De-
 pot, No. 17 Buffalo st., Rochester, N. Y.

July, 1852, M. F. REYNOLDS.

SUPERIOR GRAIN DRILL.

MANUFACTURED BY

Bickford & Huffman, Macedon, Wayne Co. N. Y.

THE above celebrated Machine has, during the past year, been more extensively introduced than any year previous, and what is most gratifying to the manufacturers, they have given most unqualified satisfaction. Double the usual quantity has been sold during the past year, mostly of nine tubes, without supplying the demand for them.

After several years experience, with our present increased facilities for their manufacture, together with some additional improvements in their construction, they are now offered to the public with increased confidence in their superiority over all other Grain Drills now in use. The grain is distributed by the means of a cylinder operated by different sized gear wheels for the purpose of distributing the quantity desired. We are manufacturing them with the drill tubes differently arranged, some with two parallel rows, the front row being seven inches forward of the back row, sowing the rows seven inches apart, thereby facilitating the passage of the drill tubes among stones and clods. Others are arranged in one row, eight inches apart; or we will manufacture them to order with the tubes arranged any distance apart required. Those ordering drills will please be particular and mention the kind they prefer. Of the great number sold, not one has been returned, although each is warranted to sow all kinds of grain with accuracy and satisfactory to the purchaser, and to be made in a workmanlike manner. Subject to this warrant, we respectfully solicit the patronage of the public, with a full conviction that they will be fully satisfied, on a fair trial, of the merits of this useful implement.

Orders for drills should be sent in early, directed to us, or to

DANIEL SUPPLE, Dundee, N. Y.;
ALFRED HALE, Alloway, N. Y.;
H. W. LEVANWAY, Lock Berlin, N. Y.;
C. L. MARSHALL, Sparta, N. Y.;
AMOS WILKITS, Aurora, N. Y.;
JOHN KING, Genoa, N. Y.;
JOHN C. HALL, Hornersville, N. Y.;
McLALLEN & HESLER, Trumansburg, N. Y.;
Col. J. M. SHERWOOD, Auburn, N. Y.;
WATERMAN & JACKSON, Vienna, N. Y.;
JAMES H. GLASS, Geneseo, N. Y.;
DAVID VER VALIN, Poughkeepsie, N. Y.;
J. H. BUTTERFIELD, Utica, Mich.;
B. B. DEXTER, Batavia, Ill.;
A. BNER WING, Geneva, Wis.

Price of Drills—\$65 for seven tube Drills; \$75 for nine tube Drills, delivered at the Canal or Railroad.

All orders thankfully received and promptly attended to.
BICKFORD & HUFFMAN.

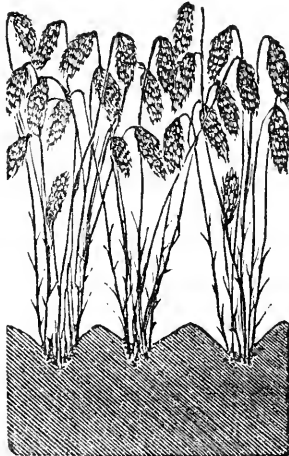
**SEYMOUR'S GRAIN DRILL.**

THIS machine proves to be better adapted to the purpose for which a Grain Drill is wanted, than any other now in use. It is not only capable of sowing wheat, but all grain

and seeds, from peas, corn, and cotton, to grass and clover seeds, either broadcast or in drills; and fine fertilizers, such as lime, plaster, guano, phosphate, bone-dust, &c., may be mixed with the grain if desired. These may all be sown broadcast with the same machine.

This machine is manufactured and for sale at East Bloomfield, Ontario County, N. Y., at the shop of P. Seymour. Also, at the shop of C. Seymour, York, Livingston County, and for sale by E. D. HALLOCK, No. 50 State street, Rochester, N. Y. Persons wishing to purchase will please call and examine at either of the above places. All orders promptly attended to.
C. H. SEYMOUR,
Sept., 1850. East Bloomfield, N. Y.

I 5000 CHALLENGE.

I OFFER to place one thousand dollars cash in the hands of a party chosen, against one thousand to be paid into the hands of the same party by any manufacturer of Threshers in the United States, if a machine can be found that will thresh and clean fit for market or seed, with the aid of only two horses, 100 bushels of wheat and rye in less time than I can with my "Excelsior Wrought Iron Cylindrical Thresher and Cleaner." The grain to be thoroughly threshed, without white caps, or broken, and the straw delivered long enough to stack, and free from chaff. The winner to receive the \$2000 with both machines and powers. For circulars, address Joseph G. Gilbert, 216 Pearl street, New York.

Gilbert's Patent Portable Excelsior Wrought Iron Thresher and Cleaner will thresh and clean grain fit for market at the rate of one-half to three-fourths of a bushel per minute, with two horses.

Urmay's Patent Railroad Power is the most durable and the cheapest power to be obtained.

Urmay's Double-gear Lever Power, for 2 to 8 horses.

Urmay's Patent Cornstalk Cutter and Grinder.

Urmay's Patent Seed Drill. Over 2000 of these machines have been sold, and have given general satisfaction.—County rights for sale for \$100 and upwards, and castings furnished to manufacture at cost prices. Profits 100 per cent. For particulars, address, post paid,

J. G. GILBERT,
August, 1852.—8-1†*2. 216 Pearl street, New York.

Valuable Virginia Land for Sale.

I OFFER for sale between 700 and 800 acres of land, handsomely located in Prince George county, Va., lying immediately on Chipcoaks creek, adjoining Lower Brandon plantation on the south, 25 miles from Petersburg. About 200 acres are cleared, and the balance tolerably well timbered with oak and pine. The cleared land was marled several years ago, and 1000 bushels of marl with 1500 bushels of lime have been recently applied to it.

The improvements are, a good brick house with five rooms, (from which there is a beautiful prospect of James river,) a kitchen, stable, smoke-house, a barn with stationary horse-power attached, and a well of good water. The buildings are within 300 yards of the main landing, where vessels load with produce, wood, &c., and unload lime at 7 cts. per bushel. Marl abounds on the opposite side of the creek. The whole tract is well watered by springs and brooks, that run through fine meadow lands, a part of which are cleared.

I will sell it entire, or in parcels to suit purchasers, as it can be advantageously divided into four farms. If not sold privately (of which due notice will be given) before the 30th day of September next, I will sell it upon the premises, on that day, at public auction, without reserve.

Persons wishing to view the property will leave the Richmond and Norfolk boat at Lower Brandon Wharf, on James River, three miles from the property; or I will give any information to those addressing me (post-paid) at Cabin Point P. O., Surry County, Va.
August 1852.—8-2t. E. T. FETTER.

Improved Stock.

CATTLE of the Durham, Devon, Hereford, Alderney, and Ayrshire breeds.

SHEEP of the Native and French Merino, Saxony, South Down, and Cotswold.

PIGS of the Lincoln, Suffolk, and Berkshire breeds.

From our long experience as breeders and dealers in the above kinds of stock, and our excellent situation for purchasing and shipping, we think we can do as good justice to orders, as any other house in the United States.

A. B. ALLEN & CO.,
April 1, 1852.—t. 189 and 191 Water st., New York.

Great Sale of Superior Thorough-bred Short-Horn Cattle.

THE subscriber will offer for sale his entire herd of choice Short-Horns, comprising 50 head, young and old, at public auction, on Wednesday, the 13th of October, 1852, at 1 o'clock P. M., at his farm, 2½ miles from the city of Troy; reserving to himself one bid on 5 cows and heifers and one bull, say six head in all, and these to be pointed out previous to the commencement of the sale. This bid will be made public when the six animals are brought to the stand for sale. Should any gentlemen advance on the single bid made by the proprietor, the highest bidder will be entitled to the animal. It is proper to say, the severe drouth in this vicinity reducing the hay crop one half, has decided the proprietor to make this sale at the time named, instead of next June, which he had purposed to do.

The well established reputation of this herd in this Union, and in Canada, and the splendid herd it has measurably sprung from, viz: the famed herd of that eminent English breeder, the late Thomas Bates, Esq., renders it hardly necessary to comment upon its superior merits. It may not however be inappropriate to remark, that the establishment of this herd was commenced in 1833, and that the most careful attention has since been paid to its breeding, and that it now contains mostly all the reserved stock of two former public sales. Since 1840, the proprietor has imported from the late Mr. Bates, and his friends and late tenants the Messrs. Bell's, 7 head of Short-Horns. And besides these, he has now on the passage across the Atlantic, shipped 21st June, on board the packet ship Kossuth, Capt. Jas. B. Bell, a superior yearling roan bull, having many crosses of the famed Duchess bulls of Mr. Bates. Including this latter animal and the two beautiful red roan 3 year old heifers which came out from England last September, "Yarn Lass" and "Yorkshire Countess" and the beautiful heifer calf of the latter animal, got in England by the Duchess bull "5th Duke of York" there will be 14 head of this imported stock, and its immediate descendants. There has been sold from this herd but 3 heifers from these importations, and these cows were sold at \$300 each. All the young bulls bred from these cows, except those now offered for sale, have also been sold at private sale, at \$300 each, most of them while quite young.

Besides these 14 head of high bred animals, the noble premium cow "Esterville 8d," bred by E. P. Prentice, Esq., of Albany, and her equally fine 2 year old, red and white heifer bred by me, got by the Bates bull "Meteor," and 3 of the famed milking Willey tribe, the same tribe of cows as the heifer "Ruby," sold by me to Mr. S. P. Chapman, of Madison county, and which cow was awarded the first premium by the N. Y. State Ag. Society, for producing the largest quantity of butter in ten days in June and ten days in August, on grass pasture only, being a fraction over 40 lbs. in those 20 days. There are other valuable tribes in the herd, as the printed catalogue will show.

The catalogue will be ready for distribution about the 1st of August, and will exhibit richness of pedigrees rarely to be met with, showing the descent of the most of the animals from the best animals on record in the English herd book. Having received an invitation from H. Strafford, last winter, to forward a list of the pedigrees of my herd, to be inserted in the forthcoming volumes of the English herd book of which Mr. Strafford is now the editor, several pedigrees were sent to him of the animals here offered for sale, and will appear in said book. Gentlemen are invited to examine the herd at any time.

A credit of 9 months will be given on all sums up to \$300, and 9 and 18 months on all sums over \$300, for approved paper, with interest, payable at some bank in this State.
Troy, N. Y., August, 1852.—S-31. GEO. VAIL.

Albany Tile Works,

No. 60 Lancaster St., West of Medical College.

THE subscriber has now on hand, and is prepared to furnish to Agriculturists, Horse-Shoe and Sole Tile, for land drainage, of the most approved patterns. They are over 1 foot in length, 2½ to 4½ inches calibre, from \$12 to \$18 per 1000 pieces—being the cheapest and most durable article used. Orders from a distance will receive prompt attention.
[4-61] JOHN GOTT, JR.

Mansfield's Clover Seed Hulling and Cleaning Machine

WAS awarded, at the Ohio State Fairs 1850 and 1851, the first premiums, Diploma and Silver Medal. Warranted to hull and clean from 20 to 40 bushels seed per day, or from two to five bushels per hour. Cash price of machine \$95. Manufactured and for sale by M. H. MANSFIELD, Ashland, Ohio.
August, 1852.—S-21*

The Water Cure Journal.

A NEW VOLUME commences with the present July number. Published monthly. Illustrated with engravings exhibiting the structure, anatomy, and physiology of the human body, with familiar instructions to learners. It is emphatically a Journal of Health, designed to be a complete Family Guide in all diseases.

TERMS.—Only One Dollar a Year, in advance. Please address, post paid, FOWLETS AND WELLS, No. 131 Nassau street, New York.

A few brief Editorial Notices may be acceptable to those unacquainted with the Journal. We copy:

From the *New York Tribune*.

"The Water Cure Journal holds a high rank in the science of health; always ready, straight-forward, and plain-spoken, it unfolds the law of our physical nature, without any pretensions to the technicalities of science, but in a form as attractive and refreshing as the sparkling element of which it treats."

From the *Fountain Journal*.

"Every man, woman, and child, who loves health, who desires happiness, its direct result, who wants to live while it does live, 'live till he dies,' and really live, instead of being a mere walking corpse, should become at once a reader of this Journal, and practice its precepts."

From the *New York Evening Post*.

"THE WATER CURE JOURNAL.—This is, unquestionably, the most popular health Journal in the world."

THIS HYDROPATHIC JOURNAL now enters upon its Fourteenth Volume, with a circulation of FIFTY THOUSAND COPIES. The ablest medical writers are among its contributors, and all subjects relating to the Laws of Life, Health, and Happiness, may be found in its pages. Now is the time to subscribe. [S-24]

Hallock's Agricultural Warehouse,

No. 50, STATE ST., ROCHESTER, N. Y.

THE Subscriber, late from the Agricultural Works, Warehouse, and Seed Store of Messrs. Emery & Co., Albany, (where he has been engaged for the past six years,) has been induced to establish an Agency for the sale of their justly celebrated Premium Horse Powers, Threshers, Separators, &c., in Rochester. Particular attention will be paid to selling and putting up the Horse Powers, and other fixtures for threshing, &c. A thorough knowledge of these machines enables him to put them up more satisfactorily than has been done heretofore. Price and terms same as at Albany, transportation added.

He will keep for sale, Emery's Seed Planters, the best in use; Circular and Cross Cut Saw Mills, Feed Mills, Corn Stalk and Hay Cutters, Corn Shellers, Churning fixtures, &c., adapted to the Power.

Also, Reapers, Mowing Machines, Grain Drills, Plows, Harrows, Cultivators, Corn Shellers, Hay Cutters, Fan Mills, and agricultural and horticultural implements generally. He will be prepared to furnish dealers with Dunn and Taylor's well known Scythes; also, Manure, Straw, and Hay Forks, Snaths, Riffes, and other haying tools, at manufacturers' prices, wholesale and retail.

Particular attention is called to a NEW PLOW, which is believed to be the best cast-iron Plow ever offered, and which is warranted to do better work, with less expense of team than any plow heretofore sold in Rochester, while the price is less than for any other equally well finished.

The "uniform one-price, cash system" will be adopted, with the prices as low as the cost of articles and just compensation for labor and time will allow. Farmers and others are invited to call and examine the stock of Machines and Implements,—and are assured no effort shall be wanting to meet promptly the wants of a discriminating public.
E. D. HALLOCK.

July, 1852.

Emery & Co.'s Improved Horse Powers, Threshers, and Separators.

THE undersigned have been appointed sole agents for the sale of Emery's new Patent Improved Horse-Powers, Threshers, and Separators, in the city of New York. The State Agricultural Warehouse is the only depot where this superior Power can be had.

LONGFETT & GRUFFING,

7-11 State Ag. Warehouse, 25 Cliff St., New York.

Prices of Agricultural Products at the Principal Markets in the United States. — Aug. 20, 1852.

	New York.		Boston.		Rochester.		Chicago.		Cincinnati.		Philadelphia.	
Beef, per 100 lbs.	\$7.00	a 9.00	a	\$7.25	\$5.50	a 6.00	\$6.00	a 6.50				
do mess, per bbl.	14.00	17.50	17.00	18.00	10.00	19.50	8.00	10.00			\$15.00	a 19.00
Pork, per 100 lbs.					7.00	7.50	5.00					
do mess, per bbl.	18.50	19.87½	20.00	24.00	16.00	19.00	16.50	17.00			19.75	20.00
Lard, per lb.	11½	12½	12	13	9	10	7	9	10	a 11	11½	12½
Butter, do	12	18	15	23	12½	14	11	13	10	14	12	14
Cheese, do	6	6½	7	8½	6	7	5	8			6	
Flour, per bbl.	4.00	5.50	4.12	5.75	4.75	5.00	3.06	3.50	3.10	3.40	4.12½	4.75
Wheat, per bush.	90	1.15	90	1.05	96	1.00	66	69	57	58	89	1.00
Corn, shelled, per bu.	67	70	70	72	54	56	46	48				70½
Rye, do	40	44½	55	57	56	62			48	53		69
Oats, do	58	62½		47	38	40	27	31	20	23	88	39
Barley, do					67	70						
Clover seed, do		7½ a 8 pr. lb.				5.50			4.00	5.00	4.87½	5.00
Timothy seed, do		\$17 to 19 per ce.	2.50	2.75	2.25	3.00		2.25	1.50	2.50	2.00	2.50
Flax seed, do		1.20	1.35	1.40	1.25	1.50		1.00	90	1.00		1.25
Hay, per ton	16.00	20.00	17.00	18.00	7.00	10.00			5.00	10.00		
Wool, per lb.	33	50		50	30	40	23	36	23	40	35	55
Wood, hard, per cord			5.00	6.50	4.00	4.50	5.00					

CONTENTS OF THIS NUMBER.

How can he get Wisdom that holdeth the Plow?	265
Experiments on Draining,	267
Artificial Manures,	269
Soil best adapted for the Culture of Wheat,	271
Leached Ashes on Wheat,	272
Peas, and Pork-Making,	273
Improved Breeds of Cattle in the West,	274
The Elements of Fertility worse than wasted,	276
CONDENSED CORRESPONDENCE.—Average Production of	
Wool per Sheep, in each of the States,	277
New Varieties of Wheat,	278
Sowing Oats with Wheat; Soaking Corn in a Solution of Hartshorn,	279
LADIES DEPARTMENT.—Forest Flowers,	288
Malope Grandiflora,	288
EDITOR'S TABLE.—Agricultural Fairs, Notices, &c.,	289
Inquiries and Answers,	290
HORTICULTURAL DEPARTMENT.	
Death of A. J. Downing,	280
The Rose-colored Weigelia,	281
Early Summer Pears,	282
The Pomological Convention,	284
The Crescent Seedling Strawberry,	285
Genesee Valley Horticultural Society,	286
Answers to Correspondents,	291

ILLUSTRATIONS.

Short-Horn Cow, "Azalia,"	275
Short-Horn Bull, "Lord Eryholm,"	275
Weigelia Rosca,	281
Pears—Amire Joannet, Little Musk, Muscat	
Robert,	282
Doyenne d'Ete, Madelaine, Skinless,	283
Malope Grandiflora,	288

Real Estate for Sale.

THE health of the subscriber having failed him, he is induced to offer for sale his Mill property, consisting of a custom Mill, recently put in a good state of repair; a Saw Mill, also recently repaired; two Dwelling Houses; a good Orchard, and about 22 acres of land, including fowage land. Said property is situated in the pleasant town of Yates, Orleans Co., N. Y., in the midst of a wealthy farming community and an excellent wheat growing country.

He has also a farm of 154 acres of first quality land adjoining said Mills, 120 acres improved, good buildings, orchards, and plenty of running water. He will sell said farm with the Mills, if desired. Inquire of the subscriber, on the premises.—[T-3t] J. C. PARSONS.

Multicaul Rye.

I HAVE grown, the present season, about two hundred bushels of this celebrated rye, for which I obtained the premium at the last State Fair. I can now, therefore, supply those who applied last year in vain, at the rate of \$2.50 per bushel. This rye has yielded with my forty bushels per acre, and furnishes abundant food for stock, as it can be sown any time between July and October, and as soon as well started should be fed down until about the 10th of May.

DANIEL P. BIGELOW.
Barre Centre, Orleans, Co., N. Y., Sept., 1852.

LINNÆAN BOTANIC GARDENS & NURSERIES

FLUSHING, (LONG ISLAND,) N. Y.

WM. R. PRINCE & CO. will sell off by the first of May next, the entire collection of Trees and Shrubbery from 50 acres of their Nurseries, and the Green-house Plants, the ground being wanted for building lots. The trees are equal to any ever grown, and comprise the choicest varieties, and sales amounting to \$250 and upwards will be made at 12 months credit for approved security.

The stock of Pears on pear and quince, and of dwarf and standard Cherries, Apples, Plums, Peaches, Grapes, Quinces, and other fruits, is unrivalled, and comprises 15,000 Fruit Trees of large bearing size.

50,000 Evergreens of every species and size, and other Ornamental Trees of every size.

3,000 finest Foreign Grapes, in pots, for grape-houses, and 15 superior varieties of hardy Native Grapes.

Five best species of European Osiers.

A great stock of Camellias, Chinese Azaleas, and other Green-house Plants.

An immense assortment of Bulbous Flower Roots and Peonies, and the finest collection of Strawberries.

New Nurseries and Cemeteries can buy to great advantage.

NOTE.—This is the proper period for transplanting Strawberries, Bulbous Roots, Peonies, Rhubarb, &c.
Sept., 1852.—9-11* \$2.

The Practical and Scientific Farmer's own Paper.

THE GENESEE FARMER,

A MONTHLY JOURNAL OF

AGRICULTURE AND HORTICULTURE,

ILLUSTRATED WITH NUMEROUS ENGRAVINGS OF

Farm Buildings, Domestic Animals, Implements, &c.

VOLUME XIII, FOR 1852.

DANIEL LEE & JAMES VICK, JR., EDITORS.

P. BAERY, Conductor of Horticultural Department.

Fifty Cents a Year, in Advance.

Five Copies for \$2—Eight Copies for \$3, and any larger number at the same rate.

All subscriptions to commence with the year, and the entire volume supplied to all subscribers.

Subscription money, if properly enclosed, may be sent (post-paid or free) at the risk of the Publisher. Address to

DANIEL LEE,

December, 1851.

Rochester, N. Y.

POSTAGE ON THE GENESEE FARMER.—50 miles or under, five cents per year; exceeding 50 miles and not over 300, ten cents; exceeding 300 and not over 1000, fifteen cents; exceeding 1000 and not over 2000, twenty cents; exceeding 2000 and not over 4000, twenty-five cents; for any distance exceeding 4000, thirty cents.

STEREOTYPED BY J. W. BROWN, ROCHESTER, N. Y.

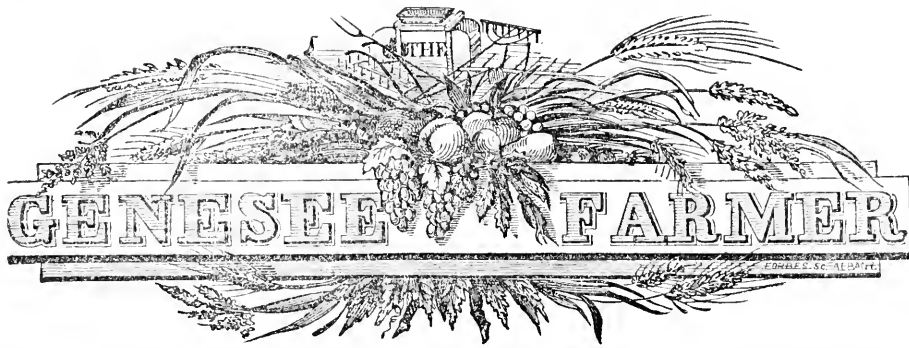

CONGRESS AND AGRICULTURE.

CONGRESS has recently adjourned, after a session of nine months; and as agriculture gives employment to two-thirds of the capital and labor of the country, it may not be amiss to inquire how much time and attention the national legislature bestowed on this most important interest. Did it give a month, a week, a day, an hour, or a minute, to the consideration of any measure designed to promote either tillage or husbandry? Being in Washington, and having a watchful eye over the farming interest, so far as it might be affected by Congressional legislation, we are able to speak understandingly on this subject. Agriculture had a few friends in both houses, but the enemies of the cause were too powerful for them to accomplish anything whatever in behalf of improvement. This failure, however, does not lessen our obligation to acknowledge in the most public manner the labors of such as tried to realize a more auspicious result. To make more friends in Congress, we must do full justice to those that serve the cause faithfully, whether they fail or succeed. Among these, we place Mr. EBEN NEWTON, of Ohio, in the front rank. Watchful, industrious, and persevering, while neglecting no other duty, he presented the paramount claims of agriculture to the attention of Congress in a manner so clear and convincing, that had the bill creating a Bureau been allowed to reach a direct vote, with the ayes and nays, we doubt not it would have passed the House of Representatives; but the committee on agriculture were not allowed by the majority even to report a bill in nine months, the chairman (Mr. FLOYD, of New York,) being opposed to all legislation for the benefit of the farming interest, as recommended by the President in his message. Gov. DOTY, of Wisconsin, was a member of that important committee, and did a yeoman's service in the cause of agriculture. To the intelligent farmers of the northwest we say, be careful to sustain this able and reliable friend of your cause. Stand by your friends, and let your enemies take care of themselves.

Of the New York delegation, we have found Mr. L. BURROWS, of Orleans county, always reliable during the three years that we have known him at the federal metropolis. Without making speeches, Mr. B. is one of the most upright, influential, and useful members in the popular branch of Congress. Mr. HORSFORD, of Livingston, who is a practical farmer, illustrated the wisdom of sending this class of men to legislate for a nation of farmers. As the latter grow in knowledge, they will be represented by fewer lawyers and more cultivators of the soil, at Washington. Mr. WALLBRIDGE, of Tompkins, and Mr. IVES, of Jefferson county, are also farmers, and most useful and faithful representatives. Sometimes we meet a narrow-minded, do-nothing farmer in Congress, but he is a *rara avis*. Among those who were ready to work for the benefit of agriculture, the name of A. P. HASCALL, of Genesee county, should not be omitted. Straight forward working men, and no other, should be sent to Congress. By all

means, let the drones remain at home, for their unworthy examples do a deal of mischief in any legislative body. Idleness, drunkenness, fighting, and blackguardism work badly with grave and peaceful legislation. In no other place is a thorough reform so much needed as at the capital of the United States. If it were possible for the people to see all that their public servants do in Washington, many a popular man would be ruined. But so long as the people are kept in ignorance of vices the most demoralizing, and of public duties uniformly neglected, neither agriculture nor any other great industrial interest will be properly attended to. The patronage of Congress and the Departments is too important to the journals of the metropolis for them to expose the shortcomings of the men that hold the strings of the public purse. Restraints more potent and salutary are greatly needed; but it is not so easy to determine from what sources they are to come. More care ought to be exercised in selecting delegates. The disposition of fifty millions a year presents numerous and powerful temptations to favoritism, fraud, and downright robbery of the treasury. One reason why nothing is done for agriculture, is that Congress has too much money to dispose of at each session. Rural sciences, and the advancement of tillage and husbandry, stand no chance in a general scramble for indefinite millions of plunder.

“THEORIES EXAMINED AND EXPLAINED.”

SUCH is the comprehensive heading of a series of articles which Mr. LEVI BARTLETT, of Warren, N. H., is writing for the *Boston Journal of Agriculture*. Hitherto three letters have appeared, all more or less directed against those who doubt the correctness of the so-called “mineral manure theory.” Number two is an examination and explanation of Mr. LAWES’ experiments and results on wheat culture, which have been published in full detail in the *Journal of the Royal Agricultural Society of England*. It is exceedingly unfortunate for the cause of truth and the advancement of agricultural improvement, that neither LIEBIG nor Mr. B. appear to have read the pamphlets written by Mr. LAWES himself, but have taken up their able pens to refute what they obtained only at second hand. Mr. B. confines himself to a few facts respecting Mr. LAWES’ experiments, which we mentioned in the June number of the present volume of the *Genesee Farmer*, when speaking of the benefits derived from plowing in green crops as manure; and upon these few facts, quoted for a special purpose, Mr. B. forms his opinion respecting the whole of Mr. LAWES’ experiments, and says:

“I presume there can be no doubt of the correctness of the experiments made by Mr. LAWES, neither of the results or conclusions to which he arrived, as regarded the particular soil upon which he experimented. To my mind, the result of his seven years’ labors does not establish any general principle in agriculture, that can be safely followed, or practically be relied upon; neither does it in any way determine the value or use of applying any of the salts of ammonia to the wheat crop, on either kinds of soil, nor does it depreciate the well known utility of manuring other soils with potash, soda, sulphate of magnesia, calcined bones, &c., or settle any other relative question,* only so far as regards the *particular soil* on which he experimented, and others of *precisely* the same *mineral and organic* composition.”

This is rather a severe judgment respecting the value of experiments which have cost at least *one hundred thousand dollars*, and been made by scientific gentlemen of acknowledged capability and accuracy. Dr. GILBERT has given his entire time to the experiments for nine years; and we presume that even Mr. B. will admit that he is a gentleman every way competent to make experiments that shall lead to the elucidation of great and fixed agricultural principles, inasmuch as he has spent considerable time in the best continental and British laboratories, and received the degree of Doctor of Philosophy from the great LIEBIG himself. Our own opinion is, that he is the most care-

ful, reliable, and best agricultural chemist in Great Britain—one who prefers to investigate the laws of nature in the field and laboratory, rather than to obtain an ephemeral popularity by writing series of gassy articles on subjects about which he has nothing new to say. If such a series of experiments as these gentlemen have made do not amount to anything, they and all other experimentalists had better quit the business, and go to work with the pen and examine and explain, *deductively*, the various theories now agitating the agricultural community. They would in this way build up a system of agriculture that would rest on an impregnable fortress—so long as experiments were held as showing nothing.

Mr. B. said he made the above statement advisedly, and promised in a future number to bring forward facts and experiments as much entitled to credence as Mr. LAWES'. We should have replied to this article sooner, but waited to see the facts promised; but in the September number of the *Journal of Agriculture*, there is another article devoted to Mr. LAWES, *but not a single fact or experiment brought forward that supports the mineral theory*, or is adverse to the theory Mr. B. is endeavoring to explain away.

Mr. B. cites JOHNSON and NORRIS, to show that nitric acid and ammonia are formed in the atmosphere; and that when lime, potash, soda, &c., are applied to the soil, nitric acid is obtained, which is equally valuable as ammonia for supplying nitrogen to plants; (?) and asks:

“Is it possible there was no nitrate of potash or soda formed from nitric acid derived from the atmosphere during the seven years course of culture, when potash and soda were so liberally supplied to the soil? Again, it is said, and pretty generally believed, that sulphate of lime (gypsum) will fix a portion of the ammonia that falls in the rains. Would not the sulphate of magnesia, (which Mr. LAWES so liberally applied to some plots of his field,) fix the ammonia of rain water, as readily as gypsum? An imperial gallon of water, at the ordinary temperature, will dissolve only about four ounces of gypsum; while the same amount of water will dissolve four pounds of sulphate of magnesia. But what is still more singular, in several instances he applied 150 lbs. of sulphuric acid, one of the most efficient agents for decomposing carbonate of ammonia, and changing it to a sulphate, one of the two compounds of ammonia, that had such a wonderful effect in doubling his crop of wheat—was there no sulphate of ammonia added to the soil during the seven years trial—from the ammonia of rain and snow water? If there was, why should not this naturally-formed sulphate have had some beneficial effect, as well as that artificially applied? To my view, some of these things are inexplicable.”

The 150 lbs. sulphuric acid was not applied in any instance in the free state, but combined with 200 lbs. calcined bone dust—thus forming the soluble article superphosphate of lime, at present so much recommended by certain parties as a manure for the wheat crop.

“Was there no sulphate of ammonia added to the soil, during the seven years' trial, from the ammonia of snow and rain water?” We answer, there was—sufficient to grow from 15 to 23 bushels, varying as less or more rain fell during the growing season, and thus supplied less or more ammonia to the plants. Mr. B. starts with the assumption that the atmosphere is capable of supplying an unlimited quantity of ammonia to the soil, providing the proper means are used to attract and fix it; and therefore the fact that sulphate of lime and sulphate of magnesia, “said and generally believed to be capable of fixing the ammonia of rain water,” did not increase the crop, while ammonia artificially supplied did greatly increase it, is “inexplicable.” Precisely it is, if the assumption is correct; but where is the proof of it. We think—not because “it is said and generally believed,” but because experiments show it—that a *good wheat soil*, if properly drained and tilled, so that the water can percolate through it, will retain all the ammonia brought to it by rain and snow water; and therefore the addition of the supposed fixers, gypsum and epsom salts, would not increase the supply of sulphate of ammonia available for the plants. We know that the amount of ammonia brought to an acre of land each year, by rain and snow, is much more than a crop of wheat ever contains; but where is the evidence that in the growth of the plant there is not a destruction of ammonia. Mr. LAWES contends that there is such a destruction, and

demonstrated it by his experiments — that, in fact, for every pound of ammonia organized in the wheat plant, there is at least five pounds of ammonia used by the plant in the performance of its functions. Mr. LAWES did not clearly perceive how and for what purpose this destruction took place, but was nevertheless convinced of the fact. Recently the experiments of Prof. WAY render it exceedingly probable that ammonia is used as the solvent and vehicle for carrying silicic acid to the plant, and *evaporating* when the silica is deposited, just as water is known to do in depositing the elements of plants. Chemists have always had a difficulty in accounting for the manner in which silica was conveyed to the plant, the theory being that it was as a soluble salt of potash or soda, and the patent of Prof. LIEBIG was for manufacturing this soluble silicate of potash, &c.; but from the fact that this patented manure has failed to increase the wheat crop, not only in England, but in Germany, under the immediate superintendence of LIEBIG himself, it is more than probable that silica is not taken up as a silicate of potash. Admit the opinion of Prof. WAY, and we can account for the benefit of summer-fallow on heavy soils — for the manner in which silica is deposited — and for the fact that in the growth of wheat there is an immense destruction of ammonia, as there would also be in the growth of all the cereals and other plants containing a large per centage of silica.

Will Mr. B. examine and explain this theory, not from what we say about it, but from the article itself, published in the last *Journal of the Royal Agricultural Society of England*?

In number three, of the series of letters, we have repeated assertions, but none of the promised experiments or facts. Mr. B. says: "At the first glance, some might be led to infer from the result of Mr. LAWS' statements, (and there can be no doubt of their correctness,) that the only thing needful for growing good crops of wheat, was *ammonia*, in one form or another." Mr. LAWES most certainly never made any such "statement" — but, as we have said before, Mr. B. does not know what Mr. LAWES has said, as he evidently has not read his articles, is ignorant of the bearing of the subject in England, and does not even know how to spell his name correctly. As our article on plowing in green crops appears to be the source of Mr. B.'s information, why does he not attempt to refute the position there maintained by us, and not attack Mr. LAWES. We never said, any more than Mr. L., that the only thing needful to grow good crops of wheat, was ammonia. We say that every mineral which enters into the construction of the plant, must be in the soil in sufficient quantity, and in an assimilable form; and that if *any one is absent, the plant will not grow at all*; if any one is deficient, there will be a deficient crop: and this, though there is a liberal supply of ammonia. But that, though there is an abundance of every inorganic constituent present in the soil, and in an available condition, yet there will not be sufficient ammonia supplied from the atmosphere to produce over an average of 17 bushels of wheat per acre; and that if we wish for an increase over this amount, ammonia must be supplied artificially.

We do not deny that there are some soils so rich in organic matter that an addition of ammonia would be worse than useless, and that on such soils mineral manures will be of great benefit; but as a general thing, on most of our soils cultivated with wheat, ammonia (on account of the destruction we have mentioned as taking place) is much sooner exhausted than even phosphoric acid, which we hold to be the first *mineral element* exhausted. We believe there is no better wheat-growing district in the United States than Western New York; yet even here we do not average more than the annual yield of wheat on the continuously unmanured acre in Mr. LAWES' experiments. Why? Is it because the minerals are deficient in the soil? If so, why is it that we can, without supplying any, still continue to grow wheat? Why is it, too, that we can obtain such splendid crops of clover, which contain precisely the same elements, and in larger quantity than the wheat crop, excepting the single element silica, or sand. But of this no one for a moment supposes our soils are deficient. How is it, too, that plow-

ing under a crop of clover benefits the wheat crop? No addition of minerals are supplied to the soil, and yet the wheat crop is greatly increased. The answer is simple and obvious—our wheat fields need a more liberal supply of ammonia, which the clover supplies.

If our wheat fields needed nothing else than the ash constituents of wheat, to keep them in a high state of fertility, and if there was no destruction of ammonia in the growth of cereals, wheat-raising on such scientific principles would be attended with much larger profits than most farmers obtain at present; and all who believe such a doctrine, should, to be consistent, rush into the business, and make their fortune by high farming. A crop of wheat of 40 bushels per acre, would take from the soil in the grain about 40 lbs. of ash. The constituents of this ash can be returned to the soil in wood ashes, salt, and animal charcoal, for less than *one dollar*; so that all we have to do to keep land yielding 40 bushels of wheat per acre, is to apply about a dollar's worth of mineral ingredients. If such a doctrine is true, *high farming* would be the most profitable business in the world. But this is not the case; and it is the necessity for, and high price of *ammonia*, that renders the production of large crops of wheat, at the present relative prices of ammonia and wheat, of doubtful economy. Are we wrong, then, in urging on our readers the importance of accumulating ammonia in every possible way on their farms, as being the only known way of increasing the average yield of wheat, corn, &c., &c. We place ammonia most prominent, because of all fertilizers it is most necessary; and we know of no way of accumulating ammonia on the farm, without at the same time increasing the indispensable inorganic constituents of plants.

BUTTER AND CHEESE MAKING.

In the May number, page 143, we gave an article on this subject, which has called forth a letter from a correspondent of the *Ohio Farmer*, in which the writer says he differs in a few things from the opinions stated in our article.

First, it is his opinion that the cause of rennet curdling milk, is the gastric juice it contains, and not, as we stated, to the addition of a *soluble highly nitrogenous ferment*, such as is formed by the *aremacausis*, or transformation of the stomach of animals during the process of making rennet.

We will admit that gastric juice is generally supposed to be the efficient agent of rennet, and that milk is immediately curdled in the stomach of animals—as every one who has been blessed with a babe must have observed—and that the stomach of animals makes better rennet than any other substance. Milk will curdle without the addition of any substance, merely by the transformation of its “sugar of milk” into lactic acid, which invariably takes place at the proper fermenting temperature, and in the presence of a nitrogenous substance, such as casein or curd. The addition of any animal membrane or meat, will accelerate this transformation or curdling of milk. Many vegetable substances will also do the same. The Jews, who were forbidden by the Mosaic law to mix meat with milk, make their cheeses with Ladies’ Bed-straw, (*Galium verum*.) In some parts of Holland, muriatic acid is used as rennet. If gastric juice is acid at all, which is somewhat doubtful, it most certainly is a very weak acid; and therefore, if it is the acid of gastric juice that is the efficient agent, large quantities would be required to neutralize the soda of milk, and precipitate the curd. But in rennet, as commonly used, there could not possibly be but a very small amount of gastric juice left. If, too, rennet acted from the acid of gastric juice, its effect would be instantaneous, or at least the precipitation of the curd would be much quicker than it is found to be in practice. Our critic offers no reasons for his opinion, we have therefore none to refute; neither does he offer any evidence against the correctness of the one we advocate.

His other objection is, that we recommend the milk to be raised to too high a temperature (95 deg. Fahr.) at the time of adding the rennet. He thinks 85 to 90 deg. the proper heat.

We know that the colder a cheese is "set," the sweeter, softer, and tenderer it will be, and have a rich buttery appearance; but at the same time there is danger of having it too cold—the curd is not all obtained from the milk, and it is very difficult to get all the whey out of the cheese, whereby it is much injured and often spoiled. We dislike a tough, dry, hard, white cheese, as much as any one, and therefore would not advise our readers to put the cheese together too warm; at the same time, we do not like a cheese that cuts like butter, and lacks that sharp, dry, cheese taste, so much sought after by good judges—such as a cheese would be if put together too cool. It is, however, possible that we have given the temperature for setting milk rather too high, and that 90 deg. would be the best average temperature. At the recent New York State Fair, where there was a splendid exhibition of cheese, we conversed with several exhibitors in respect to the process of cheese making. The temperature at which they set the milk, ranged from 85 to 96 deg. One large maker, from Herkimer county, said he did not use a thermometer, and always judged by his hand, endeavoring to get it about blood heat, (98 deg. Fahr.)—setting it a little warmer in spring and fall, than during the hot months. The celebrated Cheshire cheese is set from 90 to 100 deg., the desired temperature being 95 deg. As a general thing, the poorer the milk is in butter, the colder should it be set together; otherwise the cheese will be hard and tough.

We are glad to have our articles commented on by our readers, even in contemporary papers, hoping that truth will be drawn out, and the cause of agriculture advanced by discussion. Cheese is at present, and will continue to be, one of our great agricultural products. We wrote the article in May, for the purpose of inducing farmers to make more cheese, and hoping to throw a little additional light on the chemical and practical process of cheese making, that would not be useless even to those who have been years in the business.

DROUTH AND DEEP TILLAGE.

THE depth to which the roots of wheat, corn, clover, &c., penetrate the earth, under favorable circumstances, is much greater than is generally supposed. We have seen roots of wheat, under ordinary cultivation, that were upwards of nine feet long; and it is supposed that clover roots descend lower than wheat, though on what evidence we know not. The value of deep plowing and thorough pulverization of the soil, is now beginning to be more generally *seen*, and accordingly believed in.

There are some soils on which deep plowing would, for the first few years after the operation, prove injurious; yet in the end, under the meliorating effect of the atmosphere, the advantage of such plowing and working would be most decided. Subsoil plowing, or merely breaking and loosening the subsoil without bringing it to the surface or mixing it with surface soil, can not prove injurious on any soil, though it may the first and second year cause it to throw up a most unusual quantity of weeds, instances of which we have ourselves experienced.

We do not think it is necessary or advisable to plow deep for every crop—one good deep plowing once in four or five years being all that is required. Especially is this true where manure is applied pretty freely, and crops are grown which require most manure during the early stages of their growth.

It is rather a difficult matter to get some farmers to believe that in a very dry summer, land that is well underdrained and subsoiled, so that all water shall drain off quickly, is really wetter, or is capable of supplying more water to the growing plants,

than a similar soil undrained or shallow plowed. It is nevertheless a fact; and more and more are convinced of it each year, as they see the good effects produced. And as we believe that all which is necessary to cause a farmer to change his mode of culture, is to convince him he is in error, and to show him a better way for him to adopt, we think there can be no doubt that the next twenty years will witness a great change in our system of agriculture, and under-draining and deep plowing will be the foundation of the much needed improvement.

We have been led to these remarks, by reading an article in the *Rural New Yorker* of September 9, from the pen of LINUS CONE, Esq., of Troy, Oakland county, Mich., in which, after saying that the crops have been most seriously injured by drouth this season, he gives the following most important and interesting statement:

"As an instance to show what deep cultivation will do in time of severe drouth, I will mention a field of about six and a half acres, mostly high, dry, undulating, clayey land, which has been in grain most of the time since it was cleared—over twenty years. Five years since, it was manured with about thirty loads of coarse barn-yard manure to the acre, and planted to corn for two seasons, then barley and oats one season, wheat next, and seeded with eight or ten bushels of clover chaff and six quarts of timothy to the acre. For the barley and wheat crops it was subsoiled and made fine and mellow to the depth of twenty inches. This season it was in meadow, and a heavier growth of grass I never saw; thirty-three loads of hay were taken from it, and since it was cut the pasture has been fresh and good. Here was probably over three tons of hay per acre, while on other land in this vicinity, of similar soil, but which had been subjected to shallow tillage, the grass was light—in many cases hardly worth cutting.

"I might mention other instances to show the beneficial effect that deep cultivation has upon growing crops, but it is not necessary—it would not probably do any good even if such a statement should be made to every farmer in our land. It is so much easier to grumble about the weather than it is to put in the plow, that nearly all prefer the latter course."

The fall is the most convenient time for subsoil plowing and underdraining.

THE IMPROVEMENT OF OUR COMMON SHEEP.

In the improvement of sheep, as well as of other animals, the *male* is considered of more importance than the female, and more care is therefore necessary in selecting one; yet, for the production of perfect animals, it is absolutely essential that both male and female be well bred; and if not individually perfect in every point, the conformation of the *two* should be such as when combined would form a perfect creature. So that, in endeavoring to improve our common flocks of sheep, we should not only get good, first rate bucks, but should select out from the flock the ewes of the best age and make, to put with him; and in choosing them, should have an eye to those particular points we wish to have well developed in the lambs. In this way much may be done to improve our ordinary breeds of sheep, without much outlay in purchasing improved stock. A knowledge of the principles of breeding, and care in the selection and management of the ewes from which we intend to breed, and the choice of a buck adapted to counteract any deficiencies in the ewes, will, if judiciously persevered in for a few years, greatly improve any flock of sheep.

Farmers often procure a buck which, however useful he might be for other flocks, is altogether unsuitable for the flock he is intended to serve. Again, in a large flock of ordinary sheep there are often two or more kinds of ewes with characteristics entirely different from each other: hence a buck that might be first rate for the one, and calculated to improve the breed, would be altogether ill adapted for the other, and would propagate imperfections rather than neutralize them; yet how common is it to let the whole flock run together, and have the indiscriminate use of the same bucks. Instead of this careless, heedless, and profitless way of breeding, the flock should at this time be

judiciously assorted into lots of forty or fifty, having a buck with each lot possessing strongly the particular points in which the ewes are somewhat deficient, and in accordance with the object for which the lambs are raised. Where a small flock is kept, and only one buck is needed, a farmer can often select out some ewes of a particular conformation, that would be better served by a neighbor's buck than his own. The neighbor, too, may be in the same circumstances; and thus a change of ewes to be served by each other's buck would be mutually advantageous to the owners and beneficial to the flock.

The best time at which to place the bucks with the flock, depends a great deal on the breed of sheep and the object of the breeder. If his flock is rather coarse wooled, and he wishes early lambs for the butcher, the middle of September is perhaps not too soon. This, as ewes go twenty-two to twenty-three weeks, would bring the lambs about the first of March, which in the vicinity of large cities, where early lamb commands a good price, is the best time—yielding most profit, although a little extra care and feed are necessary. The buck in this case should be a Leicester or South Down, as their cross with common sheep gives a larger lamb, with increased tendency to fatten and early maturity. Such a cross with our common half-blooded Merino flocks produces good mutton sheep, and it is often profitable to adopt it for that purpose; but it would be folly to attempt to *breed* from such a mongrel race. We are not sure, however, but a good South Down ram would improve the size and constitution of some of our common flocks, without materially injuring the weight and quality of the wool. If, however, the object of the flock-master be merely the production of wool of fine quality, he should procure Spanish or French Merino bucks, selecting from his flock the best ewes of from three to eight years old to place with them. It is not desirable to have the lambs come till there is a prospect of grass for the mother; so the bucks should be kept from the flock till the latter part of October. And as grass is often scarce and innutritious then, it will be advisable to give a little clover hay, or perhaps oats or peas, to stimulate the ewes at that time. The buck, too, should be grained, or have a little oilcake at night, separately from the ewes. Nothing pays better than careful attention to the flock during winter; and towards spring the quality of their food should be increased, and a few ruta бага or mangel wurzel may be given with advantage.—Especially are they beneficial when the ewes are heavy in lamb, or after lambing, if grass is not ready. It is not, however, desirable to have the breeding ewes too fat; but we are sorry to say this is a caution too little needed—more flocks being injured by scant and non-nutritious food, than by over feeding.

—•••—

TO REDUCE SOLID FEET TO BUSHELS.—The publication, in your August number, without comment, of an article giving a rule “to reduce solid feet to bushels,” though perhaps correct in Indiana, where it appears to have been written, and though sufficiently accurate for ordinary purposes, is very likely to give wrong impressions of the contents of the bushel in this State. By the statute of New York, the bushel bears the same proportion to the cubic foot, that 80 does to 62 $\frac{1}{2}$. Therefore, as 62 $\frac{1}{2}$: 1728 inches :: 80 : 2211 $\frac{3}{5}$ inches, the content of the bushel—making a difference of 61 $\frac{2}{10}$ inches between the bushel of your correspondent and that established by our statute. A rule to reduce solid feet to bushels, applicable to this standard, is to multiply the number of solid feet by 25, and divide the product by 32; the quotient will be the number of bushels. A solid foot is $\frac{2}{3}$ $\frac{5}{2}$ of a bushel. The crib or box containing 64 feet, mentioned in the “example” of your correspondent, contains according to the above standard, exactly 50 bushels. A. F. H.—*Kingsbury, N. Y.*

We are happy to publish this correction of our correspondent, which is the true rule for calculating the size of the imperial bushel, now adopted as the standard. The rule previously given was correct in regard to the “Winchester bushel,” now no longer in use.

WINE-MAKING.

BY C. BLAKELY, OF ROXBURY, CONN.

In the last January number of the *Farmer* may be found some important information on the subject of making wine, together with some remarks of my own on the culture of the vine, to which, as the subject as it has been presented in your paper is by no means exhausted, I would beg leave to append a few hints for the special benefit of those of your readers who may wish to try the experiment, as many of them might easily do, of making wine on a small scale.

The manufacture of wine is, to a very great extent, a thing of mere fancy or *taste*. Few branches of business are more completely under the control of the operator, or subject to greater modifications. There are so many ways in which wine may be adulterated, and the facilities for making good imitations of the pure article without employing a single drop of grape juice are so numerous, that it is difficult for most persons to distinguish the spurious from the pure. It may be made strong or weak, and may be colored, aromatized, or flavored, to suit the fancy. This constitutes an important reason why it should be produced in every section of the country, by persons of reliability, and to an extent commensurate with the legitimate uses to which it may be applied. And why should it not be? Why purchase an article for medicinal or sacramental uses, the appropriateness of which for the purposes for which it is intended we know nothing about? Why not make for ourselves the very article we want? I propose to notice first—

The time of gathering the grapes.—There is an appropriate time for this. If too green, they will be wanting in richness, and in that peculiar *ripe*, spicy flavor, which is essential to good wine. Again, when they become too ripe, so as to be shriveled, it is a sign that much of the juice, and the gaseous aroma along with it, have made their escape by evaporation, and that the fruit is tending to decay—a state which is unsuited for making lively, delicious wine. The best time for harvesting, is when they have arrived at maturity of color and size, and before there is any tendency to decay.

To cleanse the cask.—The condition of the cask, jug, or bottle, designed for containing wine, can not be too carefully attended to. It should be free from anything like sediment, or mold adhering to the interior, the condition of which may be readily known by suspending a lighted candle by a wire within the cask. When must or acid has become fixed in the cask, it is very difficult removing either of them. A little unslaked lime dropped within the cask, with boiling water applied, so as to cause rapid ebullition, is a good thing. Water that is freely impregnated with alkaline salt, or the lye of wood ashes, is an excellent thing; also, the fumes of sulphur are used.

Fermentation.—Previous to fermentation, wine is called *must*, or *stum*. That which has been once dead and has been re-animated by means of extraneous additions, is called *stunned* wine. In the January number of your paper there are *two* fermentations spoken of, as taken from the *Review*, previous to the usual time of bottling. This is not technically correct. The second fermentation there alluded to, is but the resumption or continuation of the first, which had been retarded or suspended by the intervening* cold weather. The *season* of the year, irrespective of heat or cold, has no influence on fermentation. There are three kinds of fermentation: First, the *vinous*, producing alcohol or spirit, and giving to the liquor its peculiar stimulating and preserving qualities; second, the *acetous*, converting it into vinegar; and third, the *putrid*, destroying its vitality, and changing it into a nauseous, poisonous liquid.

When to bottle wine.—This depends on a variety of circumstances, one of which may be the legitimate offspring of another. It may be changed into vinegar in a few hours, by a process well understood by manufacturers of that article, or it may be kept for ages in its original, unfermented state, according to the treatment it may receive.

Artificial heat is sometimes employed to keep up fermentation during the winter, and fit the wine for an early market; but a temperate situation, and a gradual change from a new to the vinous state, is esteemed preferable for making good wine. For the time of bottling, see *Methods of making Wine*, hereunto appended. When the cork is driven in, which should be done with the flat side of a wooden bat, the bottle should be turned upon its side, that the liquor, and consequently the entire bottle, may resist the pressure, otherwise it will be liable to break. They should also remain on their sides, that the cork may be kept swollen, and all communication from without prevented. Atmospheric air should be excluded both from casks and bottles, and no cask but partially filled should be allowed to retain it for any considerable length of time. The influence of air, where allowed free access, will be to extract the vitality of the wine, its aroma and alcohol, and eventually to induce putrid fermentation. Besides, a scum will usually form over the surface in partially filled casks, which in time will be converted into a bitter mold, especially around the outer edge, and you have then only to shake or move the cask in order to impart a disagreeable flavor to its entire contents.

The alcoholic properties of wine.—On this head I wish to speak, inasmuch as many persons, though well informed on other subjects, entertain entirely erroneous opinions in regard to this. I have before me a copy of the *New York Evangelist*, an ably conducted religious journal, containing a highly commendatory notice of certain wines, because they are said to be “made without alcoholic additions.” Similar notices are often contained in other papers; and the inference on the part of many minds is, that it is *free* from alcohol. This, much as it is to be desired, is an impossibility! That which we technically call wine, can be preserved at a temperature of 33 deg., for then no fermentation can take place; but not in the ordinary way; nor can it even be *made* without alcohol, which is entirely the result, not of *distillation*, but of *fermentation*. The distillation of any liquid can not create a particle of alcohol; it is merely the process of separating it from the mass. When we can contrive a way to make wine without the use of sugar, either of grape or cane, which enters largely into the composition of almost every vegetable, and without fermentation or evolving carbonic acid; then, and not till then, may we have wine without alcohol. I can not see that pure brandy, the product of wine by distillation, is seriously objectionable as a preserving ingredient; but as its purity can not generally be relied on, the use of sugar of cane, which is plenty and cheap, will generally afford satisfaction. As to the per centage of alcohol necessarily employed in the preservation of wine, there seems to be no settled rule. I give below the results of several analytical experiments upon different kinds of wine, as found in *Brandé's Chemistry*, New York edition, 1821, at page 521. Seven kinds of port wine analyzed, gave results differing in strength from 19.00 to 25.83 per cent. of alcohol, which I suppose is equivalent in strength to about 38 to 51 per cent. of common brandy. Other experiments upon wines in which brandy could not have been used without destroying their identity, gave from 11.3 to 16.6 per cent. of alcohol, the highest figures indicating the strength of about 33 per cent. of common brandy. What per centage of alcohol any given quantity of sugar will yield as compared with a given quantity of brandy in the same kind of wine, I am not able to say. Will not some one inform us?

For some other valuable hints, I would refer your readers to the April number of the *Farmer*, page 117. I give below three methods of making wine, as practiced in making on a small scale.

First method.—Mix equal parts of mashed grape and water together, and let the whole remain a week without stirring; a less time will do if the weather should be unusually warm. At the end of that time, draw off the liquor and put to each gallon three pounds of sugar. Let it ferment in a temperate situation. When fermented, stop it up tight; and in about six months it will be fit to bottle.

Second method.—Put into a bottle about one-third the quantity of water that you

intend to add of grapes, and heat it as long as the hand can well endure; then put in the grapes, which will become so softened by the warm water that they may be easily mashed by the hand, and when mashed the liquor in this diluted state may be easily separated from the skins and seeds by passing it through a cullender. To each gallon of this liquor add three pounds of sugar; stir it till it dissolves; let it work as before, and bottle when it is fit, which may be in six months or a year.

The above rules will answer very well for grapes that are pulpy, having a thick coat of flesh adhering to the inner surface of the rind.

Third method.—Wash the fruit in any way you can do it most easily, and if the quantity is small, strain or squeeze the juice through a cloth strainer. This will be rather difficult if the fruit is pulpy, as the pulp will prevent the juice from percolating through. By letting it stand a day or so, it will separate more easily. Add to the juice, when extracted, from two to three pounds of sugar per gallon, according to the quality of the grape, the length of time you wish to preserve it, and the temperature at which it is intended to be kept. Three pounds of sugar is about as much as a gallon of Catawba juice will readily dissolve. One bushel of grapes will make three gallons of juice, and two and a half pounds of sugar per gallon will add to its volume about one gallon to every ten. The best of wine is made by this method; and in all cases where a superior article is intended, loaf sugar should be used. I think Mr. LONGWORTH disapproves of sugar for Catawba juice, but after a two hour's search for his paper I am unable to lay hands on it. If designed for use within a year, it may need but little extraneous to preserve it. The time for bottling, is when it arrives at the most desirable state of which it is attainable. See January and April numbers of this paper.

I present these *crude* remarks as the *fruit* however of some attention on my part, being aware that you and your readers may not exactly *relish* my *gleanings* on account of their extent, and *expressing* my regret that I have not been able to *squeeze* them into a more compact form, and to *treat* both you and them with a *richer*, more *refined*, and more *thoroughly elaborated* article; but I hope that no one will get into such a *ferment* as to cause a violent *racking* either of brains or bowels on account of it.

THE ADVANTAGE OF CUTTING CORN EARLY.—It is generally admitted that the grain of corn suffers little, if any, by cutting before fully ripe—that little nourishment is derived through the roots, during the maturing process, but that the grain obtains its food from the stalks and cobs; so that the grain is as heavy and the yield as great if cut up early and allowed to stand in the field till ripe, as if left growing till the stalks are dried up. In many districts, cornstalks form the principal winter feed for sheep and cattle; and these are often greatly reduced in value, by allowing the corn to remain uncut too late in the fall, when early frosts are frequent, and which greatly injure the nutritive qualities of the stalks as well as render them much more unpalatable to stock. After the corn is cut up, however, *frost does not injure the stalks*, as the circulation of sap, &c., is then stopped. It is nevertheless advisable to gather in the stalks as expeditiously as possible after husking, for fear of bad weather; and now that fodder is likely to be so scarce, it will be good economy to be at a little extra expense in hurrying the husking and the gathering in of the stalks. Stalks do better in stacks, if well built and covered, than they do in a close barn, where very little air can circulate through them. We would recommend scattering a peck of coarse salt to each load, when stacking the stalks; it imparts a taste to the fodder, which makes the stock eat it with much greater relish. From the effect salt has in retarding fermentation, stalks will bear to be harvested in a much greener or moister state, if salted as recommended, than when salt is not used. Carefully husband everything that will be useful as food for cattle; for in most places we shall greatly need it the coming winter.

THE EXCELSIOR CHURN.

WE have received from the patentee, G. B. CLARK, of Leonardsville, Madison county, N. Y., an engraving and description of a new churn, called the *Excelsior*. We give Mr. C.'s description, and for price, &c., the reader is referred to our advertising pages. We have never seen this churn in operation, and therefore can not speak personally of its merits, but we have seen statements from dairymen who have used them, and who speak very favorably of their operation.

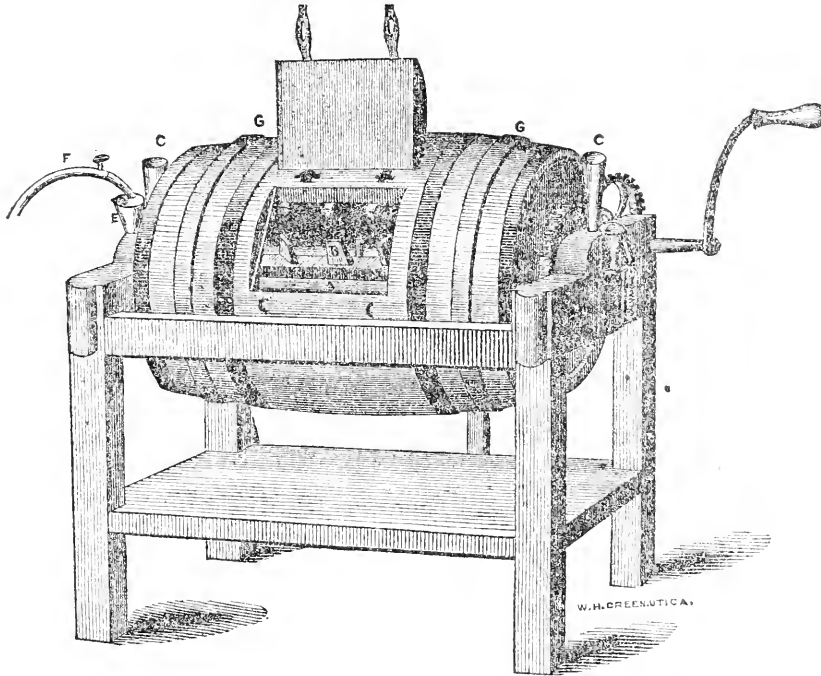

"A is the rotating or revolving body, worked by crank and gearing, as shown, or it may be attached to any motive power by passing a band directly on to its raised hoops G G. Two or more large churns can thus be driven in one frame, by passing a short band from the first cylinder to the second, and from that to a third, &c., thus affording facilities for churning any quantity of milk and cream, together or separately, at one operation. By a new and simple device, the body is easily made water tight at its lid and bearings on the fixed or permanent axles. The cross bar, or dash, is a narrow wooden bar, placed longitudinally above the center of the barrel or body, with projections (B) on its upper edge, extending upward to the periphery, at any desired angle. Pins inserted in two side staves of the cylinder, pass between the projections on the cross bar, which is removably attached, or supported by iron braces, to the axles on which the body rotates or revolves. The axles are hollow, with ventilating funnels C C, set in blocks, and extending downward into their cavities. By closing the outward end of the axles, a perfect ventilation of the cylinder is effected, even when filled above the place of its axis. The cavities of the axles permit the crooked water tubes E E to be passed through them, to be inserted in the corked ends of the small metallic cylinder in the center of the churn. Through these tubes, which close by their flanges the outward end of the axles, and being of less diameter than the cavities, so as not to obstruct the ventilation, a stream of cold water can be kept running, the water passing down the outward injecting funnel through the tube, filling the tempering cylinder, (the small tube on the cylinder should be corked after the air has escaped,) and passing out at the waste pipe. This need only be used when tempering is necessary; and where running water can not be applied, a few pails from the well will reduce the temperature sufficiently. A thermometer may be used to ascertain the temperature of the water at the waste pipe, which will indicate correctly that of the milk or cream. The cross bar, tempering cylinder, and tubes, can all be removed from the barrel of the churn, thus leaving nothing but the empty cylinder for cleansing."

Condensed Correspondence.

WEIGHT OF LEICESTER LAMBS.—I saw an article in the August number of the *Farmer*, relative to good sized lambs, which induced me to present you with the following. I also have some weighty lambs, without extra keep. One (from a yearling ewe) four months and one week old, weighs 85 lbs. Also, one which on the morning after birth weighed 14 lbs.; when four weeks old, 75 lbs.; and now, (August 26,) four months old, weighs 116 lbs. Can you beat this? They are of the Leicester breed. JAMES M. QUALE.—*Middlebury, Wyoming Co., N. Y.*

TO KILL CROWS.—In the winter, or towards spring, the crows are generally very plentiful. Take the entrails of hogs or sheep, or a dead carcass of any kind, and place it at a proper distance behind the barn, or other out-building. Then take a two inch augur and bore a hole through some convenient spot, the proper height, and remain inside after they frequent it. Then take a good fowling-piece, well loaded, and when the black gents assemble to dine, point the muzzle of your gun through the port-hole, take a dead level at the thickest part of the assembly, and let go, and the carnage will be desperate. This is no theory; it is practical experience. I think nothing of killing twenty at four shots with a small gun. I have often done it, and had crows in the spring by the bushel. If you want them for scare-crows, take out the insides and thrown in a handful of salt to preserve them, and you can have crows to hang over the fields in the spring in any quantity; and depend upon it, they are perfectly horrified at the sight, and have no idea of entering premises where their black brethren are so uncivilly dealt with. H. H.—*Einbrook, C. W.*

WOOL GROWING IN MICHIGAN, &c.—An article in the last *Farmer*, taken from the census of 1850, does not show the present state of things; still it is interesting to wool-growers. Sheep and wool have increased rapidly the past two years, since the census of 1850 was taken. We have now in Michigan over 1,000,000 of sheep, and they cut more wool per head now than the census indicates. My opinion is, that Michigan wool this season averaged 35 cents. Our wool is clean, light, and profitable for manufacturers; and they are anxious to secure the wool as soon as it is clipped. We don't oil our sheep, to make the wool grow, and add one quarter to the weight of the fleece. I never purchased any eastern sheep; my flock were principally bred on my farm, and all cut good fleeces. Some of my yearling ewes cut over six pounds river-washed wool. I sold my last spring's clip for 40 cents per pound, before removing it off the premises.

According to the *United States Economist*, published weekly by KITTLE & MORZ, Broadway, N. Y., at \$3 per annum, there are 52,422,777 pounds of wool raised in the United States. The manufacturers work up 70,862,829 pounds. The supply and growth in 1850 was within a fraction of the quantity used. In the following year, 1851, the importations were increased to 32,537,071 pounds—nearly double that of any previous year—and the manufacturers paid \$1,200,000 duty on the wool imported. The duty is 30 per cent. A SUBSCRIBER.—*Ann Arbor, Mich.*

FARMING IN INDIANA.—Being a Western New York man, and somewhat acquainted with the mode of farming and the productions of the soil there, and now spending a few weeks in this State, I will, with your permission, give your numerous readers something of an idea of what can be done in Indiana.

A day or two since, I called on Mr. HERAM BACON, who, if I mistake not, is one of your subscribers, and after consummating our business, the conversation turned to agriculture, when I drew from him the following facts: Mr. B. is a native of Massachusetts, came to this State in 1822, and located in Washington township, Marion county, upon the same farm upon which he now resides. His resident farm contains 350 acres, two hundred under cultivation, upon which he has six work horses, twenty-five milch cows, one hundred hogs, twenty-five head of young cattle, and sixty sheep; and during the past year he produced 1,650 bushels of wheat from 70 acres, 4,000 bushels of corn from 70 acres, 600 bushels of barley from 30 acres, and 300 bushels of oats from 7 acres. The value of wheat produced was \$825; cash received for pork, \$318; value of corn produced, \$800; barley, \$375; oats, \$45; butter and cheese, \$500; calves, \$50; receipts of orchard, \$100;—making the

total production of the 200 acres under cultivation, \$3,013. Mr. B. is a scientific farmer, and avails himself of every facility for conducting his farm economically. He has located under the shed of his barn one of Emery's Two-Horse Railroad Powers, which runs a cross-cut saw, for preparing fire-wood at a saving of three-fourths the manual labor; pumps the water for his stock, which saves all the labor, save that of leading the horse on the power; runs his corn-sheller, by one horse, at the rate of 500 bushels per day; and he anticipates attaching a cornstalk-cutter and a corncob-crusher and grinder. Underneath his granary may be seen his farming implements, consisting of an eight-horse traveling threshing machine, which he takes into the field, passing from shock to shock, threshing and cleaning the grain as the machine moves on, at the rate of 300 bushels per day, with the labor of four hands, leaving the straw scattered upon the ground; also, drills, cultivators, &c., too numerous to mention. He has Densmore's Self-Raking Grain Reaper, with which he cut all of his own wheat and that of several of his neighbors, and performed (I use his language) to the entire satisfaction and admiration of all who witnessed it. He also added that it would have been almost impossible for him to have got through his harvest without it, and that he saved by its use at least one bushel of wheat per acre. J. O. WILLSEA.—*Indianapolis, Ind.*

P. S.—Just as this was ready for the mail, Mr. Bacon happened in town, and the manuscript was submitted for his criticism, and it was discovered that there was a slight discrepancy in a few of the statements, viz: The pork was fattened, in part, from the corn, and the cows were fed a short time in the spring from the same production. But to offset this, I would say that there is no account made of the increase in the growth of young cattle, which was at least \$100; the increase in sheep, which was something; the potato crop, which was \$50; and many other smaller productions, of which no account is made. J. O. W.

ROTATION OF CROPS.—May it not be possible that, after all, the theory of rotation of crops is founded in error? Do we not see in nature a system entirely the reverse of rotation? Do we not observe that in nature the elements of which one particular species of plants are composed are carried back by a simple process to the earth, to form a new crop of the same species? To illustrate, do we not observe that trees, whether oak, maple, pine, or any other of the almost endless variety of trees, drop each one its own leaves at its own foot? And if we analyze the vegetable mold found, for instance, at the foot of a beech tree, may we not reasonably expect to find there the best beech tree manure? Admitting for a moment the theory of rotation to be true, ought we not to find in nature a process by which the leaves of the maple, hemlock, or some other tree, may be conveyed to the roots of the beech? Do we see such a process? Again: If certain elements, A, B, C, &c., enter into the composition of a stalk of wheat, and certain other elements, D, E, F, into the composition of a stalk of oats; and if the growth of wheat exhausts the earth of a part of the wheat-growing elements, may we not infer that the soil will be restored to its primitive condition by the restoration of the elements A, B, C; or if a crop of oats, by its corresponding elements, D, E, F? In plain English, ought we not to manure our wheat lands with wheat straw, bran, &c., and our oat fields with oat straw? Is not this nature's process? Is not the whole system of rotation of crops a suicidal policy—first exhausting the land for raising wheat, then oats, then barley, and so on *ad infinitum*—never giving back to a crop its proper nutriment, and thus in fact impoverishing the whole country? Is not the subject of sufficient importance to attract the notice of agriculturists, and institute experiments extending through a series of years, that the matter may be well understood; and if correct, adopted; if founded in error, rejected? C. B. RIDER.—*Pike, N. Y.*

It certainly is quite possible that the *theory* of rotation of crops is founded in error. It is hardly possible, however, that the *practice* of a rotation—as adopted by good practical agriculturists, and founded, not on theory at all, but on the results of close observation and long experience—is fundamentally wrong. Agriculture is not literally a natural process. Any means used to increase the natural yield of the earth, is more or less artificial. The art of agriculture may be wrong, but we necessarily must use *art* to obtain any increase over the natural yield of the soil. Will our friend point out a better system of culture—one that shall produce larger crops, and at the same time keep the soil in its original fertility.

The elements A, B, C, as well as D, E, F, enter into the composition of all our cultivated farm products. One crop does not require A, B, and C, and another crop D, E,

F; but both are composed of precisely the same elements, the only difference being in the relative proportions in which they enter the plant. There are some ten inorganic elements of plants, and four organic ones. The inorganic portion is derived wholly from the soil, the organic originally wholly from the atmosphere. The difference in the relative proportion of the inorganic elements required by different crops, is not sufficient to account for the benefit which experience proves is derived from a judicious rotation of crops; but when we look at the organic requirements of different crops, we see at once the value of rotation. Thus, to grow wheat, we require a very large amount of the organic elements nitrogen and hydrogen, which the atmosphere is capable of supplying for a small crop only. On the other hand, clover, turneps, peas, &c., are most amply provided with nitrogen and hydrogen, by the natural supply of the atmosphere. Their consumption on the farm by cattle, or by plowing them in without first passing them through the bodies of animals, furnishes an artificial supply of nitrogen and hydrogen for the wheat and other crops which require more than the atmosphere can naturally supply them.

It is mal-practicing the art of agriculture, that is a suicidal policy, and is altogether unnecessary. It is possible to exhaust the soil sooner by a rotation of crops than otherwise, simply because it increases the yield and the quantity of the elements of plants yearly exported from the farm; but a judicious system of rotation and feeding not only increases the crops, but at the same time preserves the soil in more than natural fertility.

POULTRY—THE "HEN FEVER."

By reference to the premium list of the State Agricultural Society for past years, it will be seen that no premium has ever been offered for any of the "fancy" breeds of fowls. The only premium offered for which these fowls could compete, was that offered for "the best lot of Malay or Chittagong fowls." The present year is the first that any of the "improved" kinds have been mentioned, when an offer was made for "the best lot of Shanghae, Chittagong, or Malay fowls." Notwithstanding the evident intention of the officers of the Society to discourage the breeding of improved varieties, or their refusal to acknowledge them as constituting distinct varieties or breeds, yet nine-tenths of all the fowls exhibited at Utica were of this class—showing that the framers of the premium list have labored in vain to stay the popular current. Editors of several of the agricultural papers, too, have exerted all their powers of ridicule, having drawn largely on their imagination for portraits of what they call in derision *Shang-high* fowls, and exhibited at once their wit and their folly. We have invariably observed that those who have kept the Shanghae and Cochin China, speak in their praise; and those who so freely pronounce them a humbug, and no better than the common barn-yard fowl, know nothing of them by experience.

We have received something like a dozen inquiries, during the last two or three months, as to the merits of these fowls, and their superiority over the common fowl, some of our correspondents expressing the belief that the "hen fever is all a humbug, got up by speculators for the purpose of obtaining money under false pretences." Instead of answering each inquirer in our "*Answers to Inquiries*," we shall endeavor to satisfy all in this article. Having kept "fancy" fowls, and fowls that are not considered "fancy," for several years, we shall only give the teachings of our own experience. If any of our readers differ in opinion, and will give us the facts on which their opinions are founded, we will gladly make them public.

The *Cochin China* and *Shanghae* are much larger than our common fowls, probably averaging three times their weight. Of about fifty we raised last year, the smallest hen

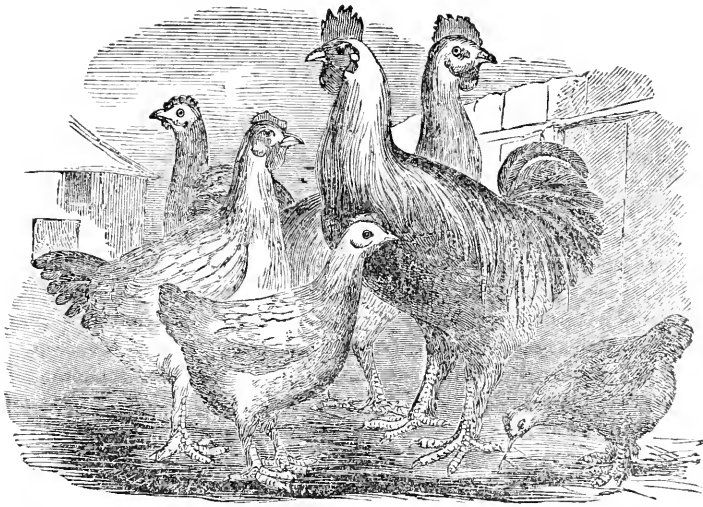

GROUP OF SHANGHAE FOWLS.

weighed six pounds, and the largest cock ten pounds, at one year old. They produce *more eggs* than any fowls we have ever kept. The hens often commence laying in less than three weeks after hatching a brood, and continue laying every day regularly, at the same time taking care of the chickens until they are able to care for themselves. We made a present of a pair of Shanghai fowls to a gentleman well known to all agricultural and horticultural readers. After a few weeks, happening to be at his place, we inquired how the fowls prospered, and was told that the hen had not layed. Thinking this strange, we asked to see what eggs they had, when we found between two and three dozen of the eggs laid by our pullet, which we readily recognized. On pointing out her eggs to our friend, he remarked: "My wife has several times observed that the hen that layed the yellow eggs, layed more than all the others." He had some half a dozen in all.

They are *good mothers*, but lay a large number of eggs before wanting to sit — generally from forty to sixty. The young chickens are very hardy — much more so than any others we know of. In several cases, when raising very late or very early chickens, we have had broods part Shanghai or Cochin China, and part common chickens, and lost nearly all the common without loosing one of the others.

The eggs of pullets the first year are small. Indeed, these fowls do not arrive at full maturity in less than eighteen months. For this reason we think it would be better to raise crosses to kill in the fall. We killed a dozen crosses last year, at about six months old, the smallest of which weighed six pounds dressed. They were from common hens and Shanghai cock. We also killed several Shanghai and Cochin China chickens at about the same age, taking a little pains to test the quality of the flesh, and disregarding the scripture injunction to call in the "halt, the lame, and the blind," invited a few of our friends who are good judges of what a fowl should be, and they were unanimously pronounced first rate, and no difference could be detected between the flesh of the crosses and pure bloods, as to fineness or flavor. There is some satisfaction in carving from a chicken that weighs from six to seven pounds.

The engraving of Shanghai fowls given in this article, were taken by an artist in our own yard. They range from six weeks to six months old. The Cochin China fowls are portraits of G. P. BURNHAM'S, of Massachusetts; and they bear such a striking

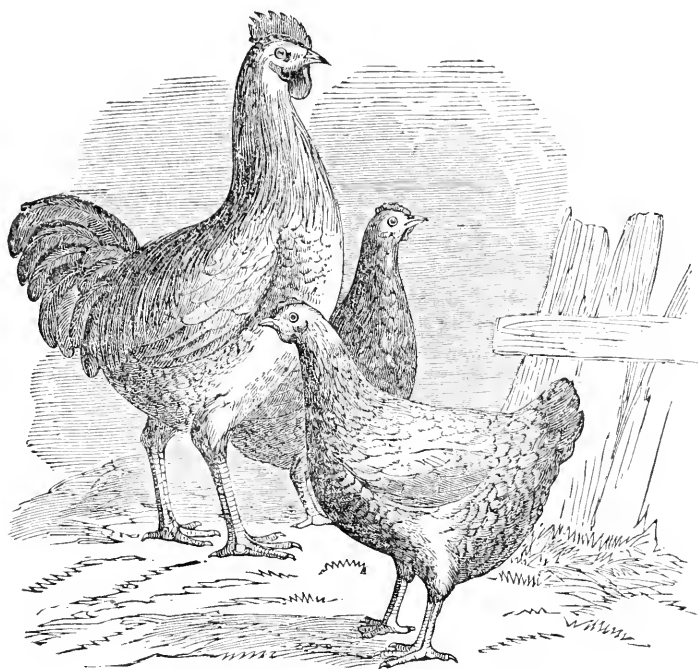

GROUP OF COCHIN CHINA FOWLS.

resemblance to our own stock, obtained from Mr. B., that we thought it useless to endeavor to take more correct likenesses. The difference between these two varieties is very slight, as is also that between the white and colored Shanghae.

That there is a good deal of humbugging and dishonesty in the chicken speculation, we too well know. We have before us a letter from a gentleman at Seneca Falls, who procured two dozen of White Shanghae eggs, at four dollars a dozen, of a person in this city, and the chickens were of all colors and all shapes, only two or three being white. We know of many others served in the same way. This same individual boasts that he has made a thousand dollars in the chicken speculation this season. He figured largely at the State Fair, and, we believe, took several premiums. We would advise our friends not to buy eggs, unless they know those with whom they are dealing to be honest. We saw at the State Fair a mongrel rooster (whose parentage we know all about, having ourselves brought the egg from which he was hatched from the east,) placed in a coop with a good hen, and labelled Cochin China; and we were told, after we left, the pair was sold for twenty-five dollars. One of our editorial brethren of the south was looking at a coop of mongrels, and observing to a friend that they were not as represented, and were not worth more than twenty-five cents each, when he was gently touched on the elbow and requested to "*speak low,*" by the owner, who was making a bargain with some green-horn for these same fowls at twenty-five dollars a pair, and which bargain he was likely to spoil. There is no need of paying such extravagant prices at the present time, even for good fowls, as there are plenty of the Shanghae fowls, both white and colored, and also the Cochin China, pure and fine, that can be had in this neighborhood for five dollars per pair. We might fill another page with the misdeeds of some of the chicken dealers, but we have given enough to place our friends on their guard.

Horticultural Department.

CONDUCTED BY P. BARRY.

HORTICULTURAL DEPARTMENT OF THE NEW YORK STATE FAIR.

THE floral tent was much less brilliant than usual, owing to the want of interior decorations, and very small and few contributions of flowers and flowering plants. The cultivators of Western New York, who usually make rich displays of flowers on such occasions, could do comparatively nothing in consequence of the severe drouth that prevailed previous to the Fair, and swarms of grass-hoppers that consumed almost everything that the drouth spared.

We noticed but two small collections of dahlias — one from EDWARD M. VAN ALSTYN, of Greenbush, and the other from WM. NEWCOMB, of Pittstown. Both were good; but, if we are not mistaken, those of Mr. VAN ALSTYN were not named, and lost much of their value in consequence. Mr. NEWCOMB also made a fine display of verbenas and seedling phloxes.

Mrs. S. E. SMITH, of Mechanicsville, presented a design worked with China asters.

JAS. WILSON, of Albany, two charming hand boquets.

MESSRS. A. FROST & Co., of Rochester, two cases of verbenas, one of asters, and one of roses and dahlias.

MESSRS. THORP, SMITH, HANCHETT, & Co., of Syracuse, a large collection of pot plants.

ELLWANGER & BARRY, of Rochester, a collection of phloxes, verbenas, roses, petunias, &c., besides green-house plants and rare evergreen trees in pots.

Tasteful ornaments of various designs, moss baskets, beautiful boquets, &c., were contributed by MESSRS. H. W. ROCKWELL, JAS. VAN NAMEE, SILAS D. CHILDS, and others, of Utica; Mrs. DUDGEN, of New Hartford; Mrs. BULLARD, and others. Most of the designs presented as floral ornaments were really chaste and pretty; but some of them, we are compelled to say, were shapeless monstrosities, at which all true taste must revolt; and we beg those who have mistakenly devoted so much labor to them, to expend it in future on objects that will do both themselves and the exhibition more credit.

The fruit department was well sustained. Indeed, we are inclined to think that, notwithstanding the earliness of the season, it was on the whole the most creditable branch of the entire show — the poultry and stove departments not excepted. The State was represented, by greater or smaller contributions, almost from one end to the other. Peaches were less abundant than usual, but pears so much better as to fully compensate for any such deficiencies. Apples and plums were also abundant and fine.

Among amateur cultivators we have to place Mr. VAIL, of Troy, at the head, as having the finest collection of fruits on exhibition; the varieties were select and fine, and the specimens really superb. His *Doyenne Boussock* pears and *Jefferson* plums attracted general attention, as did all his varieties.

P. BRETNALL, Esq., of Utica, exhibited twelve varieties of choice pears, in a very tasteful manner. We noted this as an excellent contribution.

Gen. LEWIS EATON and Prof. W. R. COPPOCK, of Buffalo, each presented a number of choice varieties.

MESSRS. N. HAYWARD & SON, of Brighton, presented a very large and fine collection of apples — probably the best that any farmers in the State could show.

The nurserymen turned out in great numbers and strength. MESSRS. C. REAGLES & SON, of Schenectady, presented a fine collection of some thirty varieties, or more, of plums.

Mr. JOHN MORSE, of Cayuga Bridge, a large collection of pears—good sorts, and fair, well grown specimens generally, though not quite as good as he has heretofore shown.

MESSRS. THORP, SMITH, HANCHETT, & Co., of Syracuse, presented some seventy varieties of pears, many of them quite new.

T. C. MAXWELL, of Geneva, presented a small collection of select pears—*Bartlett*, *Dearborn's Seedling*, *Flemish Beauty*, *Belle Lucrative*, &c.—all fine and handsome. Also, choice varieties of apples, among which a large dish of the *Primate* (once noticed in the *Farmer* as "*Rough and Ready*") attracted much attention.

JNO. C. HASTINGS, of Clinton, Oneida county, made a great display of various fruits, in large dishes of each variety.

Mr. HENRY FREEMAN, of Richfield, Otsego Co., made a handsome display of apples; and we were particularly glad to meet them from that locality. He had *Red Astracans* yet in good condition, and we noted two or three varieties of merit that are not much known. We are glad to see Otsego county enter the list of fruit growers, and with so worthy and intelligent a representative as Mr. FREEMAN.

E. G. STUDLEY, of Claverack, Columbia Co., contributed some fine samples of apples, among which are some new to our part of the State.

Preserved Fruits.—Mr. and Mrs. W. R. SMITH, of Macedon, exhibited some dozen glass jars of peaches, cherries, &c., in very tasteful style. These fruits are preserved neither in vinegar nor alcohol, but in their own natural juice. Last winter we had a jar or two of their peaches, and on opening we found the flavor little different from that of fruit just taken from the tree. This is a most useful art, and Mr. and Mrs. SMITH are improving it and practicing it on a most extensive scale.

Foreign Grapes.—Hon. JOHN GREIG, of Canandaigua, presented some very fine bunches of *Black Hamburgh*, and several other varieties. H. L. SUYDAM, of Geneva, exhibited *Black Hamburgh*, *St. Peter's*, and *Zinfindal*—superb bunches, from 2½ to 3 pounds each, well colored, and fine. We presume they took the premium. Mr. SUYDAM is a most zealous and successful amateur cultivator.

We will take this occasion to suggest an improvement much needed in the way of showing fruits offered for special premiums at these shows. There was a premium of \$10 offered for the best twenty varieties of apples. Now, the proper way would have been for all the collections offered for this premium to be placed together, side by side, without the names of the growers, but merely the numbers of entry, until after the decision of the judges. Instead of this, they were scattered about in all parts of the tent, and gave the committee a great deal of unnecessary labor; and their decisions can not be so correct as they would have been in the other case. It was the same in regard to pears and other fruits, and we trust it will receive attention before another exhibition. We will take another occasion to speak of it.

There was a premium offered for "the best collection of newly introduced pears, with description," &c. Now we consider it scarcely less than absurd to require a cultivator not only to grow the fruit and present it properly labelled, but accompanied with a *description*. It might happen that the person who presented the best collection of new pears, had not fruited them before; and how could he give a description of them? It might not be improper to ask that native and foreign sorts should be respectively so designated, but such an unreasonable condition as that alluded to is in reality a *tax* upon the introduction of new fruits, which those who made out the premium list perhaps thought it best to impose.

We have to make special mention of a fine collection of pears, consisting of 104 varieties, shown by MESSRS. HOVEY & Co., of Boston. They were very valuable as affording an opportunity to compare the growth of distant parts of the country, and to aid in correcting errors in nomenclature, where such existed.

The nurserymen and fruit growers held several evening meetings during the Fair, and

had some pleasant and profitable conversations, to which we will hereafter refer. On the whole, we believe they enjoyed the opportunity of meeting as well as any other class of men, and returned home well satisfied that their time was not lost.

We have not seen the reports of committees.

In the vegetable department the display was excellent. Indeed, we do not remember having seen a better at any previous Fair. Beets, cabbages, onions, sweet corn, Lima beans, squashes, pumpkins, tomatoes, carrots, celery, watermelons, muskmelons, potatoes, parsneps, egg plants, leeks, parsley, and indeed all the common garden vegetables, were shown in remarkable perfection. The tent appropriated to this branch was filled to overflowing, and very few inferior, poorly grown articles, were to be seen. We have never seen so many Lima beans exhibited at any show in this State, and we are very glad to see this finest of all beans receive increased attention. Potatoes, too, were exhibited in unusual abundance and perfection. Mr. C. E. GOODRICH, of Utica, made a large display of seedling varieties, said to have been grown under the direction of the State Agricultural Society. We had not sufficient leisure to examine them minutely, but we have no doubt our agricultural friends gave them due attention. Mr. G. was imparting some very valuable information, in regard to his experiments. We were particularly struck with the fine appearance of the "*Mexican*" potato in several collections, and with a variety called the "*Mackinaw White*," shown by Mr. S. H. ADDINGTON, of Marshall, near Utica. It strikes us that the attention now given to the potato, must result in great improvement. The principal contributors in this department were, Messrs. E. WILLIAMS, C. SPRATT, C. A. MANN, C. E. GOODRICH, and W. GRAY, of Utica; JAMES HALLOCK, of Whitesboro; JACOB NEW, of Canandaigua; V. W. BOYCE, Ithaca; S. H. ADDINGTON, of Marshall; N. & E. HAYWARD, of Brighton; C. F. CROSMAN and THEODORE BACKUS, of Rochester.

Rustic Work.—We had almost forgotten to mention two or three fine specimens of rustic work exhibited in Floral Hall, from a Socialist or Fourierite community in Oneida county. Two of the finest rustic chairs we have ever seen, combining great strength with elegance of design and completeness of execution; one was valued, we were informed, at \$30, and the other at \$15. A picture frame, from the same source and in the same style, was greatly admired. Would it not be well enough for the Society hereafter to offer suitable premiums for cottage and garden rustic work of this sort?

THE POMOLOGICAL CONGRESS.

This body met according to appointment, in Philadelphia, on the 13th September. There was a large attendance of delegates from several States, and a most imposing display of fruits. The President, Dr. BRINKLE, in conjunction with the Pennsylvania Horticultural Society, had made all proper arrangements for the meeting, so that there were no difficulties or obstacles to be met or overcome. The proper business of the Convention was at once entered upon, and proceeded with the greatest regularity, harmony, and dispatch. The first day was consumed in arranging the fruits, choosing officers, and organizing committees. Very little, we believe, was done in the way of discussing the merits of fruits. The retiring President, Dr. BRINKLE, who has most ably and faithfully discharged his duties, delivered an address abounding in useful suggestions for the future, and noting the more important events of the past year, such as the death of members of the Society, &c. The address was timely and able, and is justly considered as laying a broad and firm basis for future action. The second day, the various committees entered upon their duties, and the Convention proceeded with the completion of the lists of officers and committees, and at intervals with discussion on fruits.

At the close of the second day the members felt that, although the time fixed upon for adjournment had come, they were just prepared to commence a profitable session. A large number of them, ourself included, had been nearly all the time engaged on committees, and had enjoyed no opportunity for an interchange of opinion on the subjects that had been brought forward. We believe it is the general determination to occupy an entire week with the next session; and this we think will be absolutely necessary, in order to accomplish much practical good.

The Hon. M. P. WILDER pronounced an eulogy on the character of the late Mr. DOWNING, on the evening of the first day, in the Musical Fund Hall. The audience was large and select, and a mournful, solemn stillness pervaded it, indicative of a deep and melancholy interest in the theme of the oration. It was an able and elegant production, and will be published with the proceedings.

The following is a list of the officers chosen :

President.—MARSHALL P. WILDER, of Massachusetts.

Vice Presidents.—One from nearly every State and Territory, including the Canadas, California, and Oregon.

Secretaries.—F. R. ELLIOT, of Ohio; JAMES H. WATTS, of New York; H. W. S. CLEVELAND, of New Jersey.

Treasurer.—THOS. P. JAMES, of Philadelphia.

Executive Committee.—DR. W. D. BRINKLE, of Philadelphia; B. V. FRENCH, of Massachusetts; Mr. PETERS, Dr. H. WENDELL, Albany, N. Y.; Dr. J. A. WARDER, Cincinnati; and the President, and 1st Vice President ex-officio.

Committee on Foreign Fruits.—C. M. HOVEY, Massachusetts; P. BARRY, CHAS. DOWNING, J. P. KIRKLAND, New York; R. BUIST, Pennsylvania; S. L. GOODALL, Maine; C. B. LINES, Connecticut.

Committee on Native Fruits.—W. D. BRINKLE, Pennsylvania; F. R. ELLIOT, Ohio; E. TATNALL, JR., Delaware; THOS. HANCOCK, New Jersey; Col. HODGE, New York; H. P. BYRAM, Kentucky; ROBERT MANNING, Massachusetts.

Committee on Synonyms.—J. S. CABOT, Massachusetts; J. J. THOMAS, New York; A. H. ERNST, Ohio; J. A. KENNICOTT, Illinois; S. D. PARDEE, Connecticut; A. GAUL, New York; J. D. FULTON, Pennsylvania.

Chairmen of State Fruit Committees, (each one having power to select such persons, in his own State, as will constitute a complete and efficient committee.)—*General Chairman*—SAMUEL WALKER, Roxbury, Mass. New York—P. Barry, Rochester. Pennsylvania—Thomas P. James, Philadelphia. Delaware—Dr. Lewis P. Bush, Wilmington. District of Columbia—Joshua Pierce, Washington. Georgia—Stephen Elliott, Jr., Savannah. Virginia—Yardley Taylor, Purcell's Store, Loudon Co. Maine—Hy. Little, Bangor. New Hampshire—H. F. French, Exeter. Massachusetts—Ebenezer Wright, Boston. Vermont—C. Goodrich, Burlington. Rhode Island—Stephen H. Smith, Providence. Connecticut—George Gabriel, New Haven. New Jersey—Wm. Reed, Elizabethtown. Maryland—Samuel Feast, Baltimore. South Carolina—Wm. Sumner, Pomaria. North Carolina—Henry K. Burgwyn, Jackson. Ohio—R. Buchanan, Cincinnati. Illinois—J. A. Kennicott, Northfield. Indiana—J. D. G. Nelson, Fort Wayne. California—Capt. F. W. Macondray, San Francisco. Alabama—Charles A. Peabody, Gerard. Florida—A. G. Sems, Quincy, Gadsden Co. Kentucky—E. D. Hobbs, Louisville. Mississippi—Thomas Affleck, Washington. Iowa—James Grant, Davenport. Missouri—Thomas Allen, St. Louis.

A constitution was adopted, in which the name is changed to "American Pomological Society," and membership fixed at \$20 for a life member, and \$2 for a biennial membership.

A resolution was offered by Mr. ROBERT BUIST, and adopted, appointing a committee to raise a fund of \$20,000 or more, in subscriptions of \$1 and upwards, to be invested for the benefit of the widow of the late Mr. DOWNING, or to be expended otherwise in some fitting monument to his memory. The President, ROBERT BUIST, CALEB COPE, H. W. S. CLEVELAND, B. HODGE, F. R. ELLIOT, L. YOUNG, D. W. BRECKENRIDGE, and J. A. KENNICOTT, constitute such committee.

J. S. CABOT, Esq., President of the Massachusetts Horticultural Society, invited the Pomological Society to meet in Boston in 1854, and a resolution of adjournment was passed to that effect.

The details of the doings of the Society will soon reach us, and we shall then make

such extracts from the proceedings, in regard to the merits of fruits, &c., as we shall consider of more immediate interest.

THE PENNSYLVANIA HORTICULTURAL SOCIETY.—The day after adjournment, we had an opportunity of glancing over the splendid exhibition of the Pennsylvania Horticultural Society. The great hall formerly known as the Chinese Museum, was filled with pot plants, floral ornaments, and cut flowers. A fountain was playing away in the center, and close to it was a *pond*, on the bosom of which floated the gorgeous and wonderful water lily, *Victoria regia*. The specimen was small, but perfect. We noticed very large and fine old specimens of exotics, such as collections of half a century's standing could alone produce. The smaller plants were no way remarkable—at least, not remarkable for their beauty—and were so mixed up for the purpose of heightening the general effect, that they could not be well examined. The *Manellia* was trained into pretty figures, on wire; and being in full bloom, they were the most ornamental, and we think the most tasteful objects in the room. The display of cut flowers was quite below what we anticipated seeing. We noted but two or three collections of dahlias. The season has been rather unfavorable for dahlias almost everywhere, as far as we are aware.

The fruit and vegetables were shown in a hall above that devoted to the flowers, and the display of these was, in our opinion, much better than the floral; it as much exceeded our expectations, as the other fell below. The fruits were large, beautifully colored, and exhibited in large quantities, making a magnificent appearance. The size of some of the specimens surpassed anything we have seen. We had here the pleasure of making an intimate acquaintance with some Pennsylvania varieties we much desired to see at home. The show of vegetables, too, was exceedingly rich; the articles were grown in great perfection, and shown in profusion and excellent taste. There are good practical gardeners about Philadelphia, and they receive ample encouragement from a wealthy, refined, and liberal population. The markets are proof of this.

We can not now go further in noticing objects and matters of interest, but will add that our visit was a most pleasant one—by far too short. We await an opportunity to reciprocate the kind attentions shown us.

PEARS THAT SUCCEED WELL ON THE QUINCE.—During the State Fair, at Utica, a few nurserymen and fruit growers held evening meetings, for the purpose of conversation or discussion on topics connected with fruits and fruit culture. Among other subjects that came up at these meetings, was, "What pears really succeed well on the quince, after several years' trial?" The question was put, we believe, by J. J. THOMAS, and it was proposed that each one present should name such varieties as they had sufficient experience with. The following varieties, and probably a few others, were then named: *Louise Bonne de Jersey*, *Glout Morceau*, *Vicar of Winkfield*, *Urbaniste*, *Beurre Diez*, *Beurre d'Amalis*, *Panaeche*, *Long Green*, *Long Green Striped*, *White Doyenne*, *Duchesse d'Angouleme*, *Bergamotte Cadette*, *Easter Beurre*, *Doyenne d'hiver d'Alencon*, *Stevens' Genesee*, *Henry IV*, *Summer Franereal*, *Fig*, *Napolcon*, *Gray Doyenne*. We believe no one objected to any of the above twenty varieties, except *Stevens' Genesee*, with which some thought there had not yet been sufficient experience. *Urbaniste* was stated to be a slow and poor grower on the quince when young, but to improve with age.

Of gentlemen present who participated in the remarks and doings, we remember WM. R. PRINCE, of Flushing; C. M. HOVEY, of Boston; JOHN J. THOMAS, of Macedon; Prof. COPPOCK, of Buffalo; Dr. J. A. WARDER, F. R. ELLIOT, and M. KELLY, of Ohio; H. E. HOOKER, of Rochester. There is something definite and reliable in this kind of information.

THE MERVEILLE DE SEPTEMBER CHERRY.

SOME five or six years ago we received a cherry under this name, from France. We had little faith in its being of much value, and hence propagated it very sparingly. On its coming into bearing, some two or three years since, we found it small, rather dry, and of indifferent flavor, and concluded it was nearly worthless; but we find, as the tree grows older, the fruit improves both in size and quality; and this year we had two trees that bore a fair crop of handsome fruit, not first rate, but of fair quality, and ripening at an extraordinary season for a sweet cherry—the beginning of September; and if let alone by the birds, would last through the greater part of that month.

The fruit is medium size, dark purplish red, when fully ripe, resembling in size and color the *Early Purple Guigne*. The flesh is rather firm, sweet, and pleasant; must be fully ripe to be in its best condition, and appears ripe long before it is so. Worthy a place in large collections, as being the latest sweet cherry known. The tree is an erect, rapid grower, like the heart varieties, and bears fair crops. Fruit improves as the trees grow older. Season, Sept.

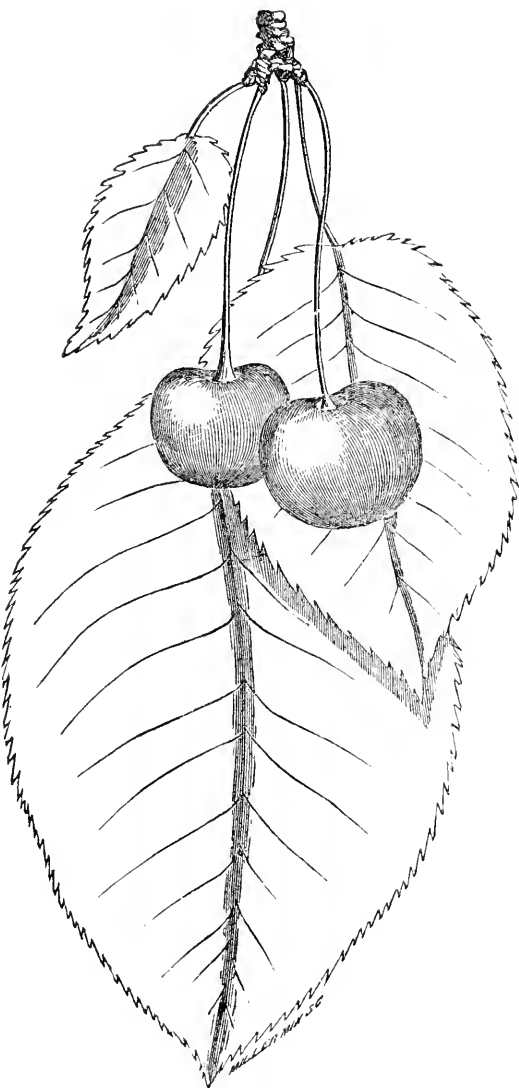

OUR space is so much occupied with notices of the Pomological Congress and the fruit exhibition of our own State Society, that we are compelled to omit other matters that should have appeared in this number.

MANUFACTURED MANURES.—A meeting of gentlemen connected with the agricultural interests in England, was recently held in London, to take into consideration measures for the reduction of the cost of guano and other portable manures. Resolutions were passed to the effect that the establishment of a public company for the manufacture of a *cheap manure equal to guano*, would be abundantly remunerative to capitalists, and a great national advantage; and that a provisional committee be appointed to carry out that object.

Editor's Table.

NEW YORK STATE FAIR.—The annual exhibition of the New York State Agricultural Society took place at Utica, on the 7th, 8th, 9th, and 10th of September, being nine days earlier than that held at Rochester last year. This alteration brought the Fair just at the busiest time of wheat sowing, and this may in part account for a considerable diminution in the number of farmers present. There was, however, on the whole, no diminution in the quality of articles exhibited, and some of the departments were superior—that of dairy products in particular. Utica being in the center of a dairy district, we expected a first rate show of cheese; but in this particular the Fair exceeded our most sanguine expectations. There were also three new cheese presses exhibited, which struck us as being improvements on all we have before seen.

In the stock department, the Durhams and Devons were well represented, both in respect to quality and numbers. There were but few Herefords and Ayrshires shown, but they were of superior character. There was one lot of Alderneys exhibited by ROSWELL L. COLT, of Patterson, N. J. This breed of cattle is very small, and it is next to impossible to fatten them; but they are said to yield richer milk, and more of it for a given amount of food, than any other. There was a good show of grade cattle, and also a very large number of good working cattle—more so than at any preceding Fair we have visited.

In farm and carriage horses, the show was not creditable, and we should judge was by no means a fair representation of the horses in the district. There was a goodly number of superior stallions and brood mares; and had we seen but these, we should have supposed the surrounding counties well supplied with superior working horses.

As fodder of all kinds is likely to be exceedingly scarce this coming winter, and there will therefore be a large demand for hay and cornstalk cutters, we were glad to see so many on exhibition from all sections of the country. One manufactured by TAYLOR, THOMAS, & Co., 125 Pearl street, N. Y., on an entirely new principle, appeared to do the work with great ease and rapidity.—“Webb's patent,” exhibited by J. E. DUTTON & Co., of Oswego county, did its work first rate.

The number of sheep exhibited was small, and, on the whole, by no means superior. There were, however, a few good specimens of the various breeds. J. D. PATTERSON, of Westfield, Chautau-

que county, N. Y., had some splendid French Merinos, and we believe took the first premium for the best pen of five ewes, and for the best buck. SHARP & TAYLOR, of Lockport, N. Y., also exhibited some beauties, recently imported by JEWETT & Co., of Vermont. They obtained the premium for the second best pen of five ewes, and for the second best buck, and also the first premium for a yearling buck. REED BURRITT, of Burdett, N. Y., exhibited a fine Silesian buck. In Long and Middle Woolled sheep there was but an indifferent show. JOHN McDONALD, of Warren, Herkimer county, N. Y., had a pen of eight Leicester ewes, which pleased us exceedingly. Mr. WAKEMAN, of Herkimer, N. Y., exhibited some very fine South Downs, as also did Col. SHERWOOD, of Auburn.

The show of hogs was small, but of very superior quality. (We wish this was a more general characteristic of our Fairs.) A. L. FISH, of Litchfield, Herkimer county, N. Y., exhibited a pen of Suffolks, which were very fine, and attracted considerable notice. This is a small breed, but matures early, and lays on fat with great rapidity. A pen of four, under one year old, of a “small breed,” belonging to JAMES PLATT, of Attica, N. Y., was very fine. There were also some very good Berkshire and Yorkshire sows, and some excellent crosses. We expected to have seen some of the Chinese breed, but were disappointed.

In the poultry department the show was excellent and very attractive.

In agricultural implements and machines the show was good, but not so extensive as was expected. J. RAPALJE & Co., Rochester, had a large assortment of all kinds of implements and machines. EMERY & Co., and WHEELER, MELICK, & Co., of Albany, were on hand with their celebrated Horse Powers, which attracted considerable attention.

The Reapers, Mowing Machines, Drills, &c., received close attention, and were much admired.

WE have to acknowledge the receipt of various favors from our friends, in the form of ripe fruit, &c. To friend PARKS, of Victor, we are indebted for fine watermelons; to H. H. GUNTER, of Gunter's Hotel, New York, for a barrel of sweet potatoes. If any of our friends visit New York city, they will find Mr. G. always at home, and attentive to their wants, at his house, 145 and 147, Fulton street.

DEATH OF J. P. NORTON.—While at the State Fair, we heard the melancholy intelligence of the death of J. P. NORTON. For some years Mr. NORTON has been at the head of the department of chemistry applied to agriculture, and the phenomena of vegetable and animal life, in Yale College. Prof. NORTON, though but a young man, only 30 years of age, had spent three years in Europe, under eminent professors in Great Britain, and on the continent, and has devoted his time and talents principally to the investigation of chemistry as applied to agriculture. Many of our young men have had the benefit of his instructions, in college, and his contributions to the agricultural press have been invaluable. In the death of NORTON and DOWNING, the friends of agriculture and horticulture have lost their brightest lights, and truly have cause to mourn. But they did a good work while the day lasted. Let us follow in their footsteps.

TERRA CULTURE.—Some correspondents have inquired whether the lecture and disclosures of Mr. COMSTOCK are worth the price charged—one dollar. If we should lecture on the importance of *doing every thing in season*—leaving nothing for the morrow that can be done to-day,—and should spend an hour in enforcing this rule upon our audience, perhaps nine out of ten might receive a dollar's worth of benefit from our lecture. Still, we might say nothing new—nothing but what others know as well as ourselves. The facts stated by Mr. COMSTOCK, are mostly to be found in horticultural works; and the little there is new in the lecture, and which Mr. C. calls his *secret*, we think is not sustained by facts. Mr. COMSTOCK shows very little knowledge of vegetable physiology. His pretensions to prevent the potato rot, the destruction of wheat by fly, weevil, &c., is the sheerest humbug. What there is *good* in the lecture, every intelligent cultivator knows; and what there is *new*, is at least very doubtful.

STATE FAIRS.—The State Fairs this year have generally been unusually successful. We shall give notices of several next month.

B. P. JOHNSON, Esq., of Albany, will accept our thanks for his interesting work on the World's Fair of 1851.

ADVERTISEMENTS, to secure insertion in the *Farm-er*, must be received as early as the 10th of the previous month, and be of such a character as to be of interest to farmers. We publish no other. Terms—\$2.00 for every hundred words, each insertion, *paid in advance*.

AGRICULTURAL FAIRS.—Below we publish all the agricultural Fairs to be held this fall that have come to our knowledge.

STATE FAIRS.

Pennsylvania, at Lancaster.....	Oct.	20, 21, 22
New Hampshire, at Meredith Bridge, ..	"	6, 7, 8
Indiana, at Indianapolis, ..	"	19, 20, 21
New Brunswick, at Frederickton, ..	"	5 to 9
Wisconsin, at Milwaukee, ..	"	6, 7, 8
Georgia, ..	"	18 to 23
Maryland, at Baltimore, ..	"	26, 27, 28, 29
American Institute, at New York, ..	"	5
"	"	19, 20, 21
Exhib. of Stock, ..	"	

COUNTY FAIRS.

Genesee, ..	Oct.	6, 7
Cayuga, at Auburn, ..	"	6, 7
Putnam, at Carmel, ..	"	5, 6
Richmond, ..	"	17
Dutchess, at Washington Hollow, ..	"	5, 6
Westchester, at White Plains, ..	"	6, 7, 8

Inquiries and Answers.

(EDWARD HEDLEY, Medina.) We do not know that there are any rabbit warrens in this or adjoining States. Have never seen the silver grey rabbit in this country.

(H. M. B., Oswego county, N. Y.) SWAMP MUCK.—The value of swamp muck, and the purposes for which it is best adapted, depend a great deal on the location in which it is formed. It is therefore impossible for us to say arbitrarily whether it would or would not be of much value as a manure for light gravelly soil.

Muck, like peat, is very insoluble, and incapable of furnishing its elements of fertility to plants until decomposed. To decompose it, however, is not an easy matter, owing to its antiseptic properties. Composting it with caustic lime or ashes, will decompose it most readily; but as these substances set free any ammonia the muck may contain, and facilitate its escape, they should not be used for this purpose. A good plan is to throw it up loosely in the fall, in some dry place, and let the frosts of winter pulverize and dry it. When dry, it may be placed in alternate layers with fresh horse manure, sea weeds, or any rapidly fermenting substance. If, too, the heap is so placed that the liquid manure of the barn-yard could be pumped upon it, so much the better. In this way it rapidly decomposes, and a manure is obtained which is valuable for most cultivated crops, especially for beets, turneps, cabbages, and other vegetables, and well repays the labor. Dry muck is also of much value as an absorbent of liquid manure, and may advantageously be used for that purpose on all farms where readily obtained. Will some of our readers who have used it, give us their experience in the best methods of digging, drying, and decomposing it, and the effects produced.

GUANO ON WHEAT.—How shall I apply guano most profitably to wheat? And what is the best method of preserving grapes in their natural state, for winter use? C. W. —*Edisonville.*

The best time to apply guano to the wheat crop, is in the fall; such is the result of experiment. As regards the best method of application, much difference of opinion exists; not so much, however, among practical farmers, as among the ranks of agricultural chemists and mere theoretical farmers. Some contend that there is a great loss of ammonia (the principal element of guano, of value to the wheat plant,) if applied to the soil, without some chemical means being used to fix it. Gypsum (sulphate of lime) is recommended for this purpose; likewise common salt, charcoal dust, and peat, have their several advocates.

If gypsum would fix the ammonia of guano, by converting it into the sulphate of ammonia, we would say, always mix plaster with the guano previous to sowing. *But it will not.* When perfectly dry, it has no effect at all on guano; but when slightly moistened with water, and allowed to remain for some time, not only will it not fix the ammonia, *but actually liberates it, and is therefore worse than useless.* It is perfectly true that, in a chemical sense, sulphate of lime will decompose carbonate ammonia, forming the fixed salt sulphate of ammonia, and the insoluble carbonate of lime. But chemists always operate with their substances in solution, and it is only when sulphate of lime is in solution that it will fix carbonate of ammonia; so that it is of no use mixing gypsum with guano, for the purpose of retaining the ammonia.

The ammonia of guano, in its unmixed state, will probably escape to some extent on exposure to the air, in consequence of decomposition; but we believe that as soon as the guano is mixed with the soil, there is no longer any evaporation of ammonia. It is known that several kinds of soils will attract ammonia; and the experiments of Mr. WAY show that some soils retain it with great tenacity.

In sowing guano on wheat, therefore, we think it a waste of time, to say the least, to be at any trouble in trying to fix the ammonia. Our method has been, first to break the lumps of the guano until they would pass through a sieve, and then re-bag, take it to the field, and sow it *alone* at the rate of two to four cwt. per acre, dragging it in immediately, sowing the wheat at the same time. This way answers well, and we know of no better.

In England, guano is often sown on the young wheat plant in early spring, and answers a good purpose in this way; but fall sowing is there con-

sidered the best by most farmers who have tried both plans.

If our friend tries guano on wheat, we hope he will let us know the result.

If it was but half its present price, the application of guano on wheat would be attended with great profit. At the present relative prices of guano and wheat, it may pay to use it, yet the prospect of *profit* is not very bright.

Preserving Grapes.—We find no difficulty in preserving grapes in a very simple way. This year we had fine *Isabellas* in abundance as late as the 20th of April. We pick the grapes on a dry day, cut out with scissors any imperfect or bruised berries, and then spread the bunches on the floor of a vacant room, or on shelves, first covering the floor with paper. We let them lie in this way about a week, and then pack them away in boxes, putting a layer of cotton batting between each layer of grapes. The boxes we put in a cool, dry place. Last year we appropriated a closet in the upper part of the house, for the purpose; and a party of friends who "tasted" our last dish of grapes, unanimously declared they were as fine as when first taken from the vines.

While on this subject, we give a new method, adopted to some extent in France, which we take from the *Albany Cultivator*:

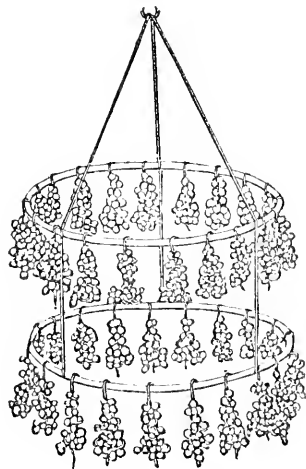

"A new method of keeping grapes in winter has been practiced in France, consisting essentially in hanging up the bunches separately, *by the smaller end* on wire hooks. Small wires, of sufficient stiffness, and a few inches in length, are bent into hooks in the shape of the letter S; one end is passed into the smaller end of the bunch, and the other placed upon a suspended hoop, as shown in the annexed figure. The position of the bunches causes every berry to hang away from its neighbor, and consequently they are less liable to rot by contact, than by any other arrangement.

The hoops are suspended by three cords or wires to a

button overhead, like the hook of a baby-jumper; and any convenient number of hoops may be hung successively under the first. The center of the fruit room may be thus occupied; and the walls may be covered by passing horizontal wires around the walls, and about a foot from them, to receive the hooks for the suspension of the bunches.

This will be found much more perfect than the more common practice of keeping grapes upon shelves or in drawers. It is hardly requisite to remind those accustomed to the successful keeping of grapes, of the necessity of careful picking, the removal of imperfect or decayed berries, and of avoiding too much moisture in the fruit room on the one hand, and of such a degree of dryness on the other as to cause wilting. The former may be prevented by chloride of lime, which absorbs moisture rapidly; and the latter by keeping the fruit room (which may be only a few feet square) *hermetically sealed*—opening the door but once a week to examine the fruit and remove any bad berries. The necessity of excluding frost is of course obvious.

SALT ON WHEAT.—What is the value of salt as a manure for wheat? H.—*Rochester, N. Y.*

If a soil is deficient in soda, common salt (which is a chloride of sodium) will supply it; and in thus supplying an actual deficiency, will be of great benefit. But soils, unless under uncommon management, are never exhausted of soda; for such is the constitution of most soils, and that of most plants grown on them, that phosphoric acid and potash would be exhausted long before soda; and as plants will not grow at all without phosphoric acid and potash, the soil could not be exhausted of soda, unless these elements had been artificially applied *alone*. Salt, then, as an actual fertilizer, we believe will do no good;—in other words, it will do no good as supplying an actual constituent of the plant. It will check *over luxuriansness of growth*, giving a stiffer and brighter straw. Prof. WAX thinks it probable that the good effect of salt, as recorded by some experimenters, is owing to the fact that the double salt of silicate of alumina and ammonia is more soluble in water impregnated with salt, than in common rain water; and that on some soils, therefore, an application of salt will be attended with considerable benefit, by rendering the silicate of ammonia available to the plant; so that an application of salt is equivalent, on that crop, to an artificial supply of ammonia. Further experiments, which are now being instituted, will doubtless throw considerable light on this interesting subject.

SHEEP RACK.—MR. BAINBRIDGE, of Romulus, wishes to know the best form for making cattle and sheep racks, and by your request, I will give you my plan of a sheep rack. Take a plank 12 feet long, 2 inches thick, and 16 inches wide, and draw a line 4 inches from the edge all around the plank; then space it $3\frac{1}{2}$ inches apart, and with a $\frac{1}{2}$ -inch auger bore your holes $1\frac{1}{2}$ inches deep in the center of the spaces you have made in the line; then make your slats or rounds 15 inches long, and put them in the holes around the plank; then take two more plank 12 feet long, 12 inches

wide, and $1\frac{1}{2}$ thick, and bore holes in the lower edge $1\frac{1}{2}$ inches deep, to correspond with the lower holes; then put the plank on the top of the slats; let the slats continue around the end of the rack as the sides; nail the ends to the side. The bottom will be eight inches wide and the top 16 inches; and if you please, you can put a cover on the top of your rack, to prevent the snow and rain getting on your fodder. This will make a rack for 25 sheep. You will see that the line is drawn 4 inches from the edge of the lower plank. This is done in order to form a manger. Take a strip of board 4 inches wide, nail on the edge of the plank all around, and this will form a good feed box. Take two pieces of timber about four inches square, and 3 feet long, pin them to the bottom of the rack about two feet from the ends, frame in the ends of your cross pieces a post 15 inches long to stand on, and so that it can be moved when you wish. J. F. HOPKINS.—*Catharine, N. Y.*

HORTICULTURAL

(J. J., Galt, C. W.) MAZZARD CHERRY.—Neither of those described is the *Mazzard*; that of which you give a sketch, is the *Prunus padus*, or bird cherry. The *Mazzard* resembles the cultivated heart cherries in both tree and fruit, and is therefore easily distinguished from those you refer to.

BUCKTHORN is quite different from the common thorn found in your forests, belonging to a different genus, (*Rhamnus*.) We would most decidedly prefer a good Buckthorn or Osage Orange hedge around a ten acre field, putting expense out of the question, to any wooden fence. We lately saw some fine samples of Honey Locust hedge, that convinced us of the practicability of making first rate farm hedges of this plant. The Osage Orange stood the last severe winter here very well in a hedge, and we have little doubt of its entire success.

Books.—*Gray's Genera of the Plants of the United States*; rather an expensive work, but complete, and just what you want, as near as it can be had.

(H. B. C., Alleghany county, Pa.) The wild rose, well managed, will make a good hedge; but an objection to it is, it throws up too many suckers. The seed of this and thorn should be buried a foot deep, or so, in dry, loamy soil, and left there for a year before sowing. They do not generally vegetate the first season.

The Fruit Garden can be sent by mail. Price, \$1.25

(J. W. H., Saratoga.) We are not acquainted with what you call "Cape Gooseberry," but may know it by another name. Will be glad to see them.

A Fruit and Model Farm and Nursery for Sale.

SAID farm received the premium in 1851, of the Alleghany County Ag. Society. It contains 190 acres of upland, with ten running springs. 800 bu. wheat, 400 bu. oats, one field corn, and 40 tons of hay, are about the product per annum. The orchard contains 2000 bearing fruit trees of 16 years growth, with grapes, strawberries, raspberries, and all kinds of berries, &c.

The buildings cost \$5000, five years ago, and consist of a brick house, bank barn, tenant house, two stone milk-houses, with all other on-buildings, &c.

100,000 nursery trees, from one to six years old, 25,000 will be fit to transplant the coming season, and my foreman will superintend it if desired, who has done so for the past five years.

Said farm is situated $4\frac{1}{2}$ miles south from the city of Pittsburgh, on the Washington turnpike road, and will be sold at a bargain, and possession given in thirty days.

Terms—\$6,000 in cash; balance from five to ten years, with interest, secured by bond and mortgage.

Having no sons, and health having failed, and age is coming on, are the reasons I offer my residence at so great a bargain. J. L. SNYDER.

Green Tree, Alleghany Co., Pa., Oct. 1851.—16-11*

Monroe Nursery.

TO those who have purchased trees of me, at the Monroe Nursery, it is unnecessary to say anything here; but the public generally I would recommend to call and examine my stock of trees, for they are, without doubt, the most thrifty and stocky that can be found in any nursery around. It is true, I can not boast of 100,000 of one kind, 100,000 of another, 50,000 of another, &c.; but this I can say, that I have 40,000 fine, thrifty, well grown apple trees, three and four years old, all of the best leading varieties, ready for delivery this fall. Also, cherries, pears, peaches, &c., in like proportion, all of which are offered low, and very low to wholesale jobbers.

My facilities for obtaining buds and scions from bearing trees, are likewise unsurpassed by any other nursery, having, since I have owned and carried on the nursery, (now going on ten years,) set out new standards of all the best leading varieties, all of which are in bearing condition.

CHARLES POWIS.

Greene, Ridge Plank Road, Oct., 1850.

French Zinc Paint.

THIS new and beautiful article of Paint is now offered to the trade and public, ground in prepared linseed oil, for the first time in this country. It has been used successfully in France for the last five years, where it has superseded white Lead as a paint.

The French Zinc when properly prepared and used, makes the most brilliant and durable white in use, and is entirely free from all poisonous qualities.

The French Zinc is not more expensive than white lead, and is prepared in such a manner that it requires no farther preparation for use, than to thin it with Turpentine or raw Oil to the consistency of white lead paint.

The French Zinc is very much whiter, and has a better body, than the New Jersey Zinc.

The French Zinc is offered dry, and prepared as above, in quantities to suit purchasers, at the Manufacturer's Depot, No. 17 Buffalo st., Rochester, N. Y.

M. F. REYNOLDS.

A Novel for the whole Union will be published soon. **NORTHWOOD**; or, **Life North and South**, showing the true character of both: By **Mrs. SARAH J. HALE**. Illustrated.

"He who loves not his country can love nothing."

The intention of this deeply interesting novel is to illustrate the dignity of labor, and show the influence of American Institutions on the character of our people both North and South. It is a book for the Nation: nothing partisan or sectional has swayed the mind of the authoress. Mrs. Hale is not tinged by any of the isms of the day, but is above any female writer of our country; a true representative of the moral dignity and grandeur of woman.

H LONG & BROTHER, No. 43 Ann street, N. Y.

This work can not fail to have a large sale, and the trade are therefore requested to send in their orders early.—Bound in cloth, price \$1; paper covers, 75 cents.

N. B.—D. M. DEWEY, wholesale and retail agent for Western New York.

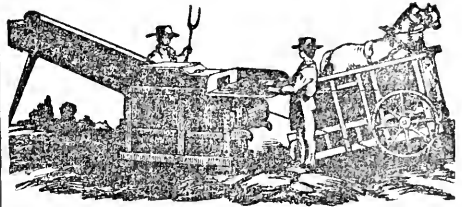

Wheeler's Patent Railway Chain Horse Power and Overshot Thresher & Separator.

THE superiority of Wheeler's Patent Railway Chain Horse Power, and Overshot Thresher and Separator is universally acknowledged. Thousands of them are in use, many of which have threshed from 50,000 to 100,000 bushels of grain, and are still in good condition. Probably more than four times as many of these machines were sold during last year as of any other kind. They are beyond doubt the most durable and economical machine in use. Their capacity has been tested by repeated trials as well as the New York and Pennsylvania Fairs as on several private occasions in competition, with another machine made in this city which has been advertised to be far superior to ours, and in every instance the result has been about one-third and in some instances more in favor of our machines. In every case except one, where we have submitted our machine to a working test at Fairs, it has taken the highest premiums; and in that excepted case the committee decided that our machine performed its work in 8 minutes and its competitor in $11\frac{1}{4}$ minutes, being nearly one-third in favor of ours.

We have also exhibited ours in competition with the same machine at the State Fairs in Ohio, Michigan, and Pennsylvania, and also at the Provincial Fair in Upper Canada, at all of which we received the highest premiums, viz: In Ohio, a Silver Medal and Diploma; in Michigan, \$20; in Pennsylvania, \$10; and in Canada, a Diploma.

We have numerous similar testimonials from county Societies, where we have always received the highest premiums awarded to Chain Powers.

Price of One Horse Power, Thresher, Separator, and Belting,.....\$120
Two Horse do.,..... 145
Price of Double Power, Thresher, and Winnower,.... 225

From R. Olney, of Portage, N. Y.

"MESSRS. WHEELER, MELICK, & Co.—I will now state some facts in regard to your Thresher and Winnower. We first used it to thresh oats, which were good and not very long straw. With five hands we threshed and cleaned, fit for any market, 60 bushels per hour while running. This is not guess work, as is frequently the case, but we kept the time to the minutes, and much larger figures might have been made had we exerted ourselves. Our wheat was heavy growth and very long straw. We averaged 20 to 25 bushels an hour, using a pair of mules and a span of very light horses alternately; but with either team alone, and five hands, I can thresh 400 bushels good oats a day, and half that quantity of wheat, and make it no harder for team or hands than ordinary farm work. The machine is admirably adapted to the farmer's use; can be worked at so little expense and in bad weather when little else can be done. It is of the most simple and durable construction, there being nothing liable to break or soon wear out but that a common farmer can repair. It cleans the grain well and wastes less than any other I ever examined. I write thus minutely that you may understand the facts as they are, the figures I have given being taken from our ordinary threshing without any effort to hurry business."

From Samuel Tucker, of North Evans, N. Y.

"MESSRS. WHEELER, MELICK, & Co.—In reply to your request about the Thresher and Winnower, I am ready to answer that it works well. Indeed its equal was never seen in Erie county. I have threshed 18,794 bushels of wheat, oats, and barley, besides 50 bushels grass seed. A number of my neighbors want machines like mine."

The subscribers have the exclusive sale of these machines in Rochester, and the general agency for Western New York. We sell at the manufacturers' prices, adding transportation.

J. RAPALJE & CO.

63 and 65 Buffalo street, Rochester, N. Y.

FISHKILL LANDING NURSERY.

TWO AND A HALF MILES NORTH FROM NEWBURGH FERRY.

THE subscriber respectfully solicits the attention of fruit growers and dealers in fruit trees, to his large stock, for sale this fall, consisting of

40,000 APPLE TREES, of the most approved varieties, 6 to 10 feet high, at from \$12 to \$14 per hundred.

30,000 PEAR TREES, embracing all the varieties in general cultivation, 5 to 8 feet high, 30 cts. each, \$25 per hundred, on pear stocks. On quince the trees are very thrifty, and include, in addition to the leading standard sorts, many of the new varieties of recent introduction, which promise well.

30,000 CHERRY TREES, two to three years old, of nearly all the popular kinds in cultivation:—Dwarfs, on Mahaleb stocks, of the choicest varieties, can also be supplied, 6 to 12 feet high, \$20 to \$22 per hundred.

20,000 PLUM TREES, of the most highly esteemed sorts, \$30 per hundred. Trees thrifty, pretty, and of fine size.

A LARGE STOCK OF APRICOT, mostly on Plum stocks, at \$30 on plum, \$12½ on peach, per hundred.

30,000 PEACH TREES, of the most valuable standard varieties, one to two years' growth on the inoculation, 7 cents each, \$6 per hundred. No peach pits are planted but from a district where the "Yellows" has not yet made its appearance.

THE STOCK OF ISABELLA AND CATAWBA GRAPE VINES is very large, two to four years old, with fine roots; having been annually cut back, they are in fine condition for vineyard planting. \$10 to \$15 per hundred.

2,000 QUINCE TREES, mostly of the Apple variety; Currant and Raspberry bushes, Strawberry plants, Hybrid Perpetual and other Roses, &c.

40,000 DECIDUOUS AND EVERGREEN ORNAMENTAL TREES, suitable for lawns and avenues, many of which are of large size and fine form—among which are 10,000 Arbor vitae, ½ to 5 feet high, \$12 to \$25 per hundred. (Not from the State of Maine.)

18,000 BALSAM FIR, ½ to 5 feet high, at from \$15 to \$30 per hundred—together with Norway Spruce, Native Spruce, Scotch, Austrian, and Weymouth Pines, Junipers, Decodar Cedar, Cedar of Lebanon, English and Irish Yew, &c.

5,000 RED CEDARS, of suitable size for screens.

15,000 Buckthorn, two years old, \$6 to \$8 per thousand.

The most highly prized varieties of the Apple, Peach, Pear, Plum, Apricot, Cherry, &c., which have recently originated in this country and Europe, have been procured as early as practicable, and tested, or are in the course of being tested, on the grounds of the proprietor. The new and rare Deciduous and Evergreen Ornamental Trees are annually imported, of which fine plants can be furnished. 4,000 seedling Oaks and Elms, imported four years since, are among the Deciduous Trees, many of them very remarkable in their growth and appearance.

The Nursery is located within 2½ miles of the Hudson River Railroad Depot, at Fishkill Landing. Steamboats run daily to New York and Albany, from Newburgh.

Trees, &c., when ordered, will be taken up carefully, correctly labelled, packed in the best manner, forwarded agreeable to order, and with the least possible delay. Charge for packing made only to cover cost.

Catalogues sent in exchange for a letter stamp.

DANIEL BRINCKERHOFF,

Fishkill Landing, October, 1852.—#4

For Sale.

ONE of the desirable farms in the Chenango Valley, situated two miles from the village of Oxford, containing 220 acres, river flat—grain land, pasture, wood land, and orcharding. A large and convenient dwelling house, two large barns, with sheds and out-houses. Watered by the Chenango river, a creek, (on which is a saw-mill) and by never-failing springs. On it are more than seven hundred rods of stone wall. Persons wishing to purchase, are desired to look at the crops and stock on the farm. Inquire of

JOHN TRACY,

Oxford, N. Y.

Oct., 1852.—10-2t*

King's Floral Garden and Nursery.

THE proprietor offers for sale, this fall and the coming spring, at his Nursery and Flower Garden, Mount Hope avenue, Rochester, a large and choice variety of Fruit and Ornamental Trees, Shrubs, Vines, Roses, Herbaceous Plants, Bulbous Roots, Greenhouse, Border, and Bedding Plants, Double Dahlias, &c., wholesale and retail.

A few thousand apple stocks, Norway Spruce and Balsam Fir seedlings, Red and White Cedar. The trees are of large size and thrifty growth, and will be sold cheap for cash.

WM. KING.

LINNÆAN BOTANIC GARDENS & NURSERIES,
FUSHING, (LONG ISLAND) N. Y.

WM. R. PRINCE & CO. desire to sell off by the first of May next, the entire collection of Trees and Shrubbery from 50 acres of their Nurseries, and the Green-house Plants, the ground being wanted for building lots. The trees are equal to any ever grown, and comprise the choicest varieties, and sales amounting to \$250 and upwards will be made at 12 months credit for approved security.

The stock of Pears on pear and quince, and of dwarf and standard Cherries, Apples, Plums, Peaches, Grapes, Quinces, and other fruits, is unrivalled in extent and in vigor of growth, and among them are 15,000 Fruit Trees of large bearing size.

50,000 Evergreens of every species and size, and other Ornamental Trees of every size.

3,000 finest Foreign Grapes, in pots, for grape-houses, and 15 superior varieties of hardy Native Grapes.

The collection of Strawberries is the finest in the Union, comprising many varieties not obtainable elsewhere, and all described in the catalogue.

Five best species of European Osiers.

A great stock of Camellias, Chinese Azaleas, and other Green-house Plants.

An immense assortment of Bulbous Flower Roots and Peonies, and the finest collection of Strawberries.

New Nurseries and Cemeteries can buy to great advantage.

NOTE.—This is the proper period for transplanting Strawberries, Bulbous Roots, Peonies, Rhubarb, Asparagus, Sea Kale, &c.

Descriptive catalogues sent to all applicants who send stamps, and a wholesale catalogue for nurseries.

Oct., 1852.—10-1t*2.

Clarke's Excelsior Churn,

OF various forms and sizes, will be furnished to dairymen, throughout the United States, at prices ranging from \$2.50 to \$10. The sizes generally preferred, with iron axles, crank, and gearing, will be delivered at Utica, for Canal or Railroad, at \$7 and \$10 each. No extra charge is made for the perfect tempering apparatus which goes with every Excelsior Churn. Three or more thirty gallon milk churns in one frame, for horse power, are offered at about \$5 per cylinder. Orders from distant places should enclose payment. Agents wanted to sell state and county rights. Circulars giving full information, terms to agents, &c., will be sent gratuitously to all who apply at any time post-paid, to the proprietor

GEO. B. CLARKE,

Lebanonville, Madison Co., N. Y.

The following is one of the many testimonials of its value:

"Sangerfield, Oneida Co., N. Y., July 25, 1852.

"GEO. B. CLARKE—Sir: The Excelsior Churn now in use in my dairy, does the work in a superior manner, and is just the article to make good butter. I do not care to churn less cream than will produce twenty pounds of butter at a time, which I usually do in from ten to twenty minutes. It is my opinion that your Excelsior Churn has no rival in point of excellence.

HEZEKIAH S. GREEN.

Virginia Farms.

THE advertiser offers for sale a plantation of 390 acres in an excellent neighborhood, three to four hours ride from the capital of the State, one mile of railroad, mostly in original growth. Good house with five rooms, out kitchen, &c. Well watered by creeks and never-failing springs. Well adapted for wheat, corn, and oats. A portion valuable low grounds, actually worth \$50 per acre. Healthy as any part of the world. Enough wood may be sold from the place to pay for it. Lowest price—\$1,600 cash; or \$1,900 cash, and interest on the balance.

Also, a place of 1400 acres, thirty miles from the city of Petersburg, three miles from railroad depot. 500 acres valuable timber, that would fully pay for the place. Suitable for division. Good buildings. A truly valuable plantation. Fine neighborhood. \$5 per acre. 2,000 acres may be bought adjoining.

Also a tract of 150 acres, directly on a railroad, 18 miles from the city. \$4 per acre—cheap as dirt.

Also, a tract of 453 acres, four miles from the city of Petersburg, with plenty of marl, buildings somewhat out of repair. \$7 per acre.

The above plantations are well worth the attention of northern farmers, and will be sold for the prices stated, and no less. Cash, or part cash and interest added. Address

J. CLARKE, JR.,

Proctor's Creek, Chesterfield Co., Va.

10-1t*3

FRUIT AND ORNAMENTAL TREES.

ELLWANGER & BARRY desire to call the attention of nurserymen, dealers, and planters, to the immense stock of trees now on their grounds, embracing Fruit Trees of every description, viz:

STANDARD APPLES, PEARS, PLUMS, CHERRIES, PEACHES, &c., on free stocks, for orchards, vigorous and well formed.

DWARF and PYRAMIDAL PEAR TREES, on quince stocks. About 100,000, embracing every fine variety that can be so worked, two year old trees, low branched, vigorous and beautiful.

DWARF and PYRAMIDAL CHERRIES, on Mahaleb stocks. Fine one, two, and three years old trees, well branched and finely formed.

DWARF APPLE TREES, on Paradise and Doucain stocks. Beautiful two year old trees, with heads, for immediate bearing—besides vigorous yearlings.

GOOSEBERRIES.—Large Lancashire sorts. Strong plants for immediate bearing.

CURRENTS.—Including the *Cherry, Victoria, White Grape*, and many other new and fine sorts. See our catalogue.

RASPBERRIES.—The new *Large fruited Monthly, Fastoff, &c.*, &c. A complete collection of all desirable varieties.

GRAPES.—Hardy, native sorts—*Isabella, Catawba, Clinton, &c.*—strong two and three year old vines. Thirty varieties of Foreign Grapes, for vineries—strong, thrifty plants, in pots.

STRAWBERRIES of all desirable varieties, and all other fruits cultivated.

RHUBARB.—Genuine *Myatt's Victoria, Myatt's Linxus, Mitchell's Royal Albert, Downing's Colossal*, and hybrids of the above, of our own raising from seed, quite equal to any of them.

The entire fruit department is under our own personal supervision. The best quality of stocks is used, and the most scrupulous attention given to ensure accuracy. We flatter ourselves that no nursery collection can offer a stronger guarantee to purchasers, in this respect. The stock is all grown on new, fresh soil, and is healthy, well matured, and hardy. We ask purchasers to examine it.

ORNAMENTAL.—Large trees, for streets, parks, &c., such as *Horse Chestnuts, Silver Maples, Sugar Maples, Snowy Ablers, Mountain Ash, Elms, and Tulip Trees*, in large quantities, cheap.

RARE ORNAMENTAL LAWN TREES—embracing the most novel, remarkable, and beautiful trees and shrubs, both deciduous and evergreen, that can be grown in our climate. For particulars we must refer to the descriptive catalogue.

ROSES.—One of the richest collections in the country, including the newest and best European varieties, selected by us in person, last summer.

BULBous ROOTS—Imported annually from Holland.

DAHLIAS.—The new English and French prize sorts of 1851, besides fine older ones.

All articles packed in the best manner, and forwarded to any part of the United States, Canada, or California.

Orders strictly complied with in every particular.

The following catalogues are sent *gratis* to all who apply and enclose stamps to cover postage, which must be prepaid:

- No. 1. A Descriptive Catalogue of Fruits.
- No. 2. A Descriptive Catalogue of Ornamental Trees, Shrubs, &c.
- No. 3. A Catalogue of Dahlias, Fuchsias, Chrysanthemums, and bedding plants.
- No. 4. A Wholesale Catalogue, for nurserymen and others who wish to purchase largely.

Postage on Nos. 1 and 2—500 miles or under, 3 cts.; 500 to 1500 miles, 6 cts. Postage on Nos. 3 and 4—500 miles or under, 1 cent; 500 to 1500 miles, 2 cts.

Mount Hope Nurseries, Rochester, N. Y., Sept., 1852.

Emery & Co.'s Improved Horse Powers, Threshers, and Separators.

THE undersigned have been appointed sole agents for the sale of Emery's new Patent Improved Horse-Powers, Threshers, and Separators, in the city of New York. The State Agricultural Warehouse is the only depot where this superior Power can be had.

LONGETT & GRIFFING,

7-ft. State Ag. Warehouse, 25 Cliff st., New York.

Seigner & Shipton's Grain Drill.

THIS is a new Drill, recently patented, combining more good qualities than any other drill now in use. These drills are manufactured and sold by J. RAPALJE & CO., Genesee Seed Store and Agricultural Warehouse, Nos. 63 and 65 Buffalo street, Rochester, N. Y.

SYRACUSE NURSERIES.

THORP, SMITH, HANCHETT, & CO., PROPRIETORS.
SYRACUSE, N. Y.

OUR nursery grounds, among the largest and most extensive in the country, are now covered with a most beautiful stock of Fruit and Ornamental Trees, Shrubbery, Roses, Green-house Plants, &c. We therefore invite particular attention to our stock of trees, which can not be excelled in size, thriftiness, and beauty, by those of any other establishment in the Union. Nurserymen, Amateurs, Orchardists, and Venders, are earnestly invited to call, examine, and judge for themselves.

APPLES.—We have a very extensive assortment of all the very best varieties in cultivation, both Dwarf and Standard.

PEARS.—Our stock of Standards and Dwarfs is much better than heretofore; and we invite competition, as none finer can be produced. We have also a few dwarfs five years old, filled with fruit spurs, and which have borne freely the past two years. (and now with a full crop,) that we will supply to those persons desiring fine fruit-bearing trees.

CHERRIES.—Both Standard and Dwarf, of all the newest and finest sorts, which can not be excelled for beauty and thriftiness.

PLUMS, PEACHES, APRICOTS, NECTARINES, CURRANTS, (including the *Victoria* and *Cherry*), and **ENGLISH GOOSEBERRIES**, of all the best leading sorts.

OUR **ORNAMENTAL TREES** are of fine form and luxuriant growth, and require only to be seen to be admired.

EVERGREENS.—A fine assortment of *Norway* and *Balsam Firs, Spruces, &c.*

PEONIES.—A splendid assortment of both tree and herbaceous varieties.

DAHLIAS.—Over 150 choice selected kinds, at 25 cents for whole roots.

ROSES.—One of the largest stocks in the country, of all the leading varieties, being about 10,000 plants.

BULBous ROOTS.—A splendid assortment, just imported from Holland, of best double *Hyacinths, Tulips, Crocus, &c., &c.*

GREEN-HOUSE PLANTS.—A large collection of the choicest and newest kinds, including the new *Heliotropes Reptans, &c., Lantana Ercingii, Hoyas, Imperialis, Bella, Bidacelliana, &c.*

FUCHSIAS in 50 varieties, including *Spectabilis, Eliza Millie, Sir John Fastoff, Serratifolia, Prince of Orange, Carolina, Pearl of England, &c.*

CHRYSANTHEMUMS.—A full assortment of all the best standard kinds in the country. Of the *New Dwarf and Daisy* varieties we have everything new and rare, including 30 of the very best sorts.

VEGENAS.—A splendid collection of 50 varieties, including *Hovey's New Seedlings.*

STRAWBERRIES.—All the best varieties, including the 2 new Cincinnati sorts, one of which took the \$100 premium.

HEDGE PLANTS.—*Buck Thorn, Privet, Red Cedar, and Osage Orange.*

SEEDLING STOCKS.—Nurserymen and others can be supplied with Apple, Pear, French Quince, Mahaleb, Doucain, and Paradise stocks, by giving us notice in due time.

Our Catalogues, with full descriptions and prices, will be forwarded to every post-paid applicant enclosing one letter stamp, if under 500 miles, and three stamps if over that distance.—9-2t. THORP, SMITH, HANCHETT, & CO.

FRUIT & ORNAMENTAL TREES.

RIVER BANK NURSERY, ROCHESTER, N. Y.

SHEPPARD & CHERRY, PROPRIETORS, NOW offer to furnish nursery stock generally, of as good quality, and at as low rates, as can be obtained elsewhere.

FRUITS of all the leading varieties, both standard and dwarf, of Apples, Cherry, Peach, Pear, Plum, &c., &c. Gooseberries, Currants, Raspberries, Strawberries, &c. Grapes—*Isabella, Catawba, Clinton, &c.*

Also 100,000 apple stocks, for root grafting. 20,000 Cherry stocks, root pruned.

All orders accompanied with cash or satisfactory reference, and all letters of inquiry post-paid, will receive prompt attention.

From the connection of Mr. Sheppard for a number of years with the following establishments, all of which sustain the highest reputation, viz: A. J. Downing and A. Saul, Newburgh, N. Y.; Wm. Reid, Elizabethtown, N. J.; and Ellwanger & Barry, Rochester, N. Y.; the proprietors flatter themselves that their knowledge of the great variety of tastes and wants of planters generally, will enable them to guarantee ample satisfaction to all favoring them with their patronage.—9-2t.

C. J. RYAN & CO.,
PROPRIETORS OF THE ROCHESTER AND CHAR-
LOTTE PLANK-ROAD NURSERIES,
Rochester, N. Y.,

OFFER for sale, as follows, at moderate prices:

10,000 Apple trees, from five to eight feet high, four years old. All the principal early and late sorts. Also, Pear, Peach, Plum, and Cherry trees—all thrifty and in good order for transplanting.

20,000 Raspberries, including all the popular market varieties.

5,000 Isabella Grape vines, three years old, propagated from cuttings, not from layers—will bear fruit at once.

1,500 Apricot trees—large and thrifty—full of fruit buds.
 50,000 Cherry seedlings, (Black Mazzard,) in fine order. They will all bud next year.

25 distinct varieties of Strawberries, among them the principal productive and high flavored sorts.

10,000 Rhubarb Roots. Downing's Colossal, Giant, and Myatt's Victoria.

190,000 Giant Asparagus roots, two and three years old.—Every family ought to have a bed of this delicious vegetable of the easiest culture.

Sea Kale and Horse Radish.

Hedge Plants, such as Privet, Osage Orange, and Buckthorn, one and two years old.

Our Ornamental trees are straight and handsome. All the most desirable varieties under cultivation.

Shrubs, Running and Shrubby Roses, Ornamental Vines, &c., &c., cultivated largely, and will be sold low.

Our nursery land is principally a mellow, sandy loam, which furnishes our trees with tufts of fibres, and gives them a decided advantage over trees cultivated in stiff clay or wet land, which generally produces long, bare roots, without fibres.

All orders addressed to us, as above, will be promptly attended to.

See our General Descriptive and Annual Catalogues, which will be sent gratis to all post paid applicants.

The extensive pear, peach, cherry, and apple orchards connected with these nurseries, give them facilities which are seldom equalled in the propagation of nursery stock. All our scions and buds are cut from bearing trees; and if there is a possibility of having fruit trees accurate to name and description, we have every facility for doing so.

September, 1852.—9-21.

Hallock's Agricultural Warehouse,

No. 50. STATE ST., ROCHESTER, N. Y.

THE Subscriber, late from the Agricultural Works, Warehouse, and Seed Store of Messrs. Emery & Co., Albany, (where he has been engaged for the past six years,) has been induced to establish an Agency for the sale of their justly celebrated Premium Horse Powers, Thrashers, Separators, &c., in Rochester. Particular attention will be paid to selling and putting up the Horse Powers, and other fixtures for thrashing, &c. A thorough knowledge of these machines enables him to put them up more satisfactorily than has been done heretofore. Price and terms same as at Albany, transportation added.

He will keep for sale, Emery's Seed Planters, the best in use; Circular and Cross Cut Saw Mills, Feed Mills, Corn Stalk and Hay Cutters, Corn Shellers, Churning fixtures, &c., adapted to the Power.

Also, Reapers, Mowing Machines, Grain Drills, Plows, Harrows, Cultivators, Corn Shellers, Hay Cutters, Fan Mills, and agricultural and horticultural implements generally. He will be prepared to furnish dealers with Dunn and Taylor's well known Scythes; also, Manure, Straw, and Hay Forks, Snaths, Rifles, and other haying tools, at manufacturers' prices, wholesale and retail.

Particular attention is called to A NEW PLOW, which is believed to be the best cast-iron Plow ever offered, and which is warranted to do better work, with less expense of team than any plow heretofore sold in Rochester, while the price is less than for any other equally well finished.

The "uniform one-price, cash system" will be adopted, with the prices as low as the cost of articles and just compensation for labor and time will allow. Farmers and others are invited to call and examine the stock of Machines and Implements,—and are assured no effort shall be wanting to meet promptly the wants of a discriminating public.

E. D. HALLOCK.

July, 1852.

Northern N. Y. Live Stock Insurance Company, Plattsburgh, N. Y. For terms, please apply to agents of the Company.

Great Sale of Superior Thorough-bred Short-
Horn Cattle.

THE subscriber will offer for sale his entire herd of choice Short-Horns, comprising 50 head, young and old, at public auction, on Wednesday, the 13th of October, 1852, at 1 o'clock P. M., at his farm, 2½ miles from the city of Troy; reserving to himself one bull on 5 cows and heifers and one bull, say six head in all, and these to be pointed out previous to the commencement of the sale. This bid will be made public when the six animals are brought to the stand for sale. Should any gentleman advance on the single bid made by the proprietor, the highest bidder will be entitled to the animal. It is proper to say, the severe drought in this vicinity reducing the hay crop one half, has decided the proprietor to make this sale at the time named, instead of next June, which he had purposed to do.

The well established reputation of this herd in this Union, and in Canada, and the splendid herd it has measurably sprung from, viz: the famed herd of that eminent English breeder, the late Thomas Bates, Esq., renders it hardly necessary to comment upon its superior merits. It may not however be inappropriate to remark, that the establishment of this herd was commenced in 1833, and that the most careful attention has since been paid to its breeding, and that it now contains mostly all the reserved stock of two former public sales. Since 1849, the proprietor has imported from the late Mr. Bates, and his friends and late tenants the Messrs. Bell's, 7 head of Short-Horns. And besides these, he has now on the passage across the Atlantic, shipped 21st June, on board the packet ship Kossuth, Capt. Jas. B. Bell, a superior yearling roan bull, having many crosses of the famed Duchess bulls of Mr. Bates. Including this latter animal and the two beautiful red roan 3 year old heifers which came out from England last September, "Yarm Lass" and "Yorkshire Countess" and the beautiful heifer calf of the latter animal, got in England by the Duchess bull "5th Duke of York," there will be 14 head of this imported stock, and its immediate descendants. There has been sold from this herd but 3 heifers from these importations, and these cows were sold at \$300 each. All the young bulls bred from these cows, except those now offered for sale, have also been sold at private sale, at \$300 each, most of them while quite young.

Besides these 14 head of high bred animals, the noble premium cow "Esterville 3d," bred by E. P. Prentice, Esq., of Albany, and her equally fine 2 year old, red and white heifer bred by me, got by the Bates bull "Meteor," and 3 of the famed milking Willey tribe, the same tribe of cows as the heifer "Ruby," sold by me to Mr. S. P. Chapman, of Madison county, and which cow was awarded the first premium by the N. Y. State Ag. Society, for producing the largest quantity of butter in ten days in June and ten days in August, on grass pasture only, being a fraction over 40 lbs in those 20 days. There are other valuable tribes in the herd, as the printed catalogue will show.

The catalogue will be ready for distribution about the 1st of August, and will exhibit richness of pedigrees rarely to be met with, showing the descent of the most of the animals from the best animals on record in the English herd book. Having received an invitation from H. Stafford, last winter, to forward a list of the pedigrees of my herd, to be inserted in the forthcoming volumes of the English herd book of which Mr. Stafford is now the editor, several pedigrees were sent to him of the animals here offered for sale, and will appear in said book. Gentlemen are invited to examine the herd at any time.

A credit of 9 months will be given on all sums up to \$300, and 9 and 18 months on all sums over \$300, for approved paper, with interest, payable at some bank in this State.

Troy, N. Y., August, 1852.—8-31.

GEO. VAIL.

Prices of Manures.

Peruvian Guano, 2½ to 2⅔ cts. per lb.
 Improved Superphosphate of Lime, (Mapes,) 2⅔ cts. per pound.

Superphosphate of Lime, (Extra No. 1, Duburg's,) 2⅔ cts. per lb.

Bone dust, when taken in equal quantities, \$2.25 per bbl.

Bone sawings, separately, \$2.50 per lb.

Wood's Renovating Salts, 1 cent per lb.

Sugar-House Bone Black, \$3 per hhd.

Potash, 3½ to 4 cts. per lb.

Charcoal, pulverized, \$1 per bbl.

Sulphuric acid, 2½ to 2⅔ cts. per lb.

Plaster of Paris, \$1 to \$1.25 per bbl.

For sale at the State Agricultural Warehouse, No. 25 Cliff street, New York.

LONGETT & GRIFFING.

September, 1852.—9-21.

Prices of Agricultural Products at the Principal Markets in the United States. — Sept. 20, 1852.

	New York.		Boston.		Rochester.		Chicago.		Cincinnati.		Philadelphia.	
Beef, per 100 lbs.	\$7.00	a 9.00	a	\$7.25	\$5.50	a 6.00	\$6.00	a 6.50				
do mess, per bbl.	12.00	16.00	15.00	17.00	10.00	10.50	8.00	10.00				\$18.00 a 19.00
Pork, per 100 lbs.					7.00	7.50	5.00					
do mess, per bbl.	19.00	19.12½	20.00	21.00	16.00	19.00	17.00	19.00	\$19.25	19.50	19.75	20.00
Lard, per lb.		11½	12	13	9	10	9	10	10	a 11½	11½	12½
Butter, do	14½	22½	16	21	16	18	10	12½	11	16	12	14
Cheese, do	6	6¾	4	7	6	7	5	8	6	6½		
Flour, per bbl.	4.25	5.75	4.12	5.75	4.50	4.75	3.50	4.25	3.30	3.60	4.50	4.87½
Wheat, per bush.	90	1.11	90	1.05	96	98	45	53	57	60	95	1.06
Corn, shelled, per bu.	70	72	70	74	54	56	46	48½	40	42		70½
Rye, do		86	78	80	56	62			48	53		74
Oats, do		43	46	47	34	37	26	28	23	25	34	37
Barley, do	74	78			67	70			40	50		
Clover seed, do		8 a 8½	pr. lb.	8 a 11	per lb.	5.50			4.00	5.00	4.75	5.00
Timothy seed, do		\$18 to 20	per tee.	3.00	3.25	2.50	2.63		1.75	2.00	2.75	3.25
Flax seed, do	1.45	1.50	1.33	1.50	1.25	1.50	1.00			90		
Hay, per ton	20.00	25.00	20.00	21.00	11.00	13.00			5.00	10.50		
Wool, per lb.	35	52	40	50	30	40	23	36	28	45	37½	60
Wood, hard, per cord			5.00	6.00	4.00	4.50	4.00					

CONTENTS OF THIS NUMBER.

Congress and Agriculture.....	297
"Theories Examined and Explained,".....	298
Butter and Cheese Making.....	301
Drouth and Deep Tillage.....	302
The Improvement of our common Sheep.....	303
To reduce Solid Feet to Bushels.....	304
Wine Making.....	305
The advantage of cutting Corn early.....	307
The Excelsior Churn.....	308
CONDENSED CORN-POUNCE.—Weight of Leicester Lambs; To Kill Crows; Wool Growing in Mich- igan, &c.; Farming in Indiana.....	309
Rotation of Crops.....	310
Poultry—the "Hen Fever,".....	311
EDITOR'S TABLE.—New York State Fair.....	320
Death of John P. Norton; Terra Culture; Agri- cultural Fairs, Notices, &c.....	321
Inquiries and Answers.....	321
HORTICULTURAL DEPARTMENT.	
Horticultural Department of the New York State Fair.....	314
The Pomological Congress.....	316
Pears that succeed well on the Quince.....	318
The Merveille de Septembre Cherry.....	319
Answers to Correspondents.....	323

ILLUSTRATIONS.

Excelsior Churn.....	308
Group of Shanghae Fowls.....	312
Group of Cochín China Fowls.....	313
Merveille de Septembre Cherry.....	319
Frames for preserving Grapes.....	322

BOOK AGENTS WANTED.

GOOD salesmen can earn from \$1 to \$3 per day, in selling AGRICULTURAL BOOKS.

POLITICAL CAMPAIGN BOOKS,
LARGE AND SMALL BIBLES,
POLITICAL AND OTHER PICTURES,

Uncle Tom's Log Cabin; Uncle Tom as it is; Northwood, Mrs. Hale's new book; Cheap Publications; Gold Medals, Gen. Scott and Gen. Pierce; together with other new books.

I will furnish agents with from \$15 to \$30 worth of books for cash, and take back all the unsold books and refund the money. Agents can make from 25 to 100 per cent. profit, and in this way are not compelled to keep their stock if not sold. Books can be sent by Express to any address. Money can be safely sent by mail. Address

D. M. DEWEY,
Oct., 1852. Arcade Hall, Rochester, N. Y.

Charles Moulson

OFFERS for sale at his nursery on North Union street, a large stock of Fruit Trees, consisting of Apples, Pears, Plums, Cherries, Peaches, and Apricots, of the most desirable varieties.

Currants, Gooseberries, Strawberries, and Grapes, of various kinds.

Also, a fine assortment of dwarf pears.

20,000 seedling apples, for stocks.

Rochester, October, 1852.—10-11*

S. MOULSON.

OLD ROCHESTER NURSERY.

OFFICE, 36 FRONT STREET, ROCHESTER, N. Y.
20,000 Northern Spy apple trees, 6 to 8 feet high, (transplanted,) at 37½ cents each, or \$25 per hundred.

50,000 most popular varieties of apple, at 25 cents each, or \$18 per hundred.

1,000 dwarf apple, at 37½ cents each.

60,000 dwarf pear, at 50 cents each.

20,000 standard pear, at 50 cents each.

20,000 standard and dwarf cherry, at 50 cents each.

10,000 Giant rhubarb, at 25 cents each, \$2 per dozen, or \$60 per thousand. Best sort for market gardeners.

Also, a large assortment of apricot, peach, nectarine, strawberry, various sorts of nuts, &c., &c.

50,000 Osage Orange, for hedges, at \$10 per thousand, or \$6 for five hundred. Hedge plants in great variety.

50,000 Norway Spruce, two years old, at \$5 per hundred.

20,000 " three " at \$10 to \$12 "

20,000 Mountain Ash, two years old seedlings, at \$20 per thousand, or \$12 for 500.

Bulbous flower roots of various sorts, together with a large assortment of various hardy items, comprising everything requisite for open ground culture in this climate.

Lists of leading items forwarded to post paid applicants enclosing a one cent postage stamp for under 500 miles, and two for over. Packing done in the best manner. Orders solicited, by mail or otherwise.

The Practical and Scientific Farmer's own Paper.

THE GENESEE FARMER,

A MONTHLY JOURNAL OF

AGRICULTURE AND HORTICULTURE,

ILLUSTRATED WITH NUMEROUS ENGRAVINGS OF

Farm Buildings, Domestic Animals, Implements, &c.

VOLUME XIII, FOR 1852.

DANIEL LEE & JAMES VICK, JR., EDITORS.

P. BARRY, Conductor of Horticultural Department.

Fifty Cents a Year, in Advance.

Five Copies for \$2—Eight Copies for \$3, and any larger number at the same rate.

All subscriptions to commence with the year, and the entire volume supplied to all subscribers.

Subscription money, if properly enclosed, may be sent (post-paid or free) at the risk of the Publisher. Address to

DANIEL LEE,

December, 1851.

Rochester, N. Y.

POSTAGE ON THE GENESEE FARMER.—50 miles or under, five cents per year; exceeding 50 miles and not over 300, ten cents; exceeding 300 and not over 1000, fifteen cents; exceeding 1000 and not over 2000, twenty cents; exceeding 2000 and not over 4000, twenty-five cents; for any distance exceeding 4000, thirty cents.

STEREOTYPED BY J. W. BROWN, ROCHESTER, N. Y.

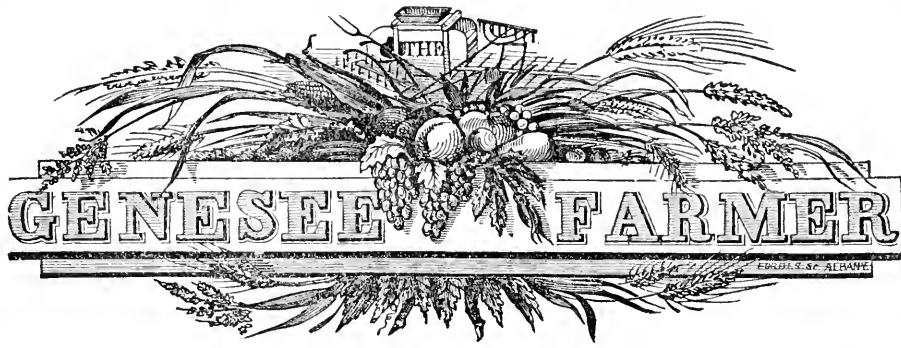

VOL. XIII.

ROCHESTER, N. Y., NOVEMBER, 1852.

No. XI.

THE FUTURE OF THE GENESEE FARMER.

ONE more number completes the present volume of the *Genesee Farmer*, and ends our labors for the year 1852. We have spared neither labor nor expense to make the monthly visits of our journal interesting and profitable to our numerous readers. Grateful to its numerous friends for the unparalleled favor with which it has been everywhere received, our devotion to their best interests shall prove how sincerely we thank them, and appreciate all their kindness. We never had any private business to promote by writing for the agricultural press, either north, south, or at the federal metropolis; and therefore we may say with equal truth and sincerity, that the interests of our readers are our interests; and that we desire no other.

Agriculture and Horticulture are great and enduring interests; they are susceptible of large and indefinite improvement. To effect this, we have sought to unite the advocates of agricultural progress in all the States into one national body, that something may be done in our lifetime in behalf of agricultural text-books, experimental farms, schools, and rural science, worthy of a republic in which farmers constitute the ruling majority. But every step we have taken that appeared likely to improve anything, has encountered opposition from the ignorant, the selfish, and the prejudiced. If public opinion be not yet ripe to sustain a national agricultural Society, nor one experimental farm, agricultural or horticultural school, in America, the fault is not ours; nor shall we abate our humble efforts to bring public opinion up to that degree of enlightenment which will regard the science of agriculture as not less worthy of colleges, museums, professional libraries, laboratories, and lecture rooms, than the science of medicine.

In a field so broad as the United States, it is not always easy to determine at what point one's services will be most useful to an interest that employs over five thousand million dollars capital, and labor in proportion. Such an interest demands a very comprehensive and perfect organization, having its head at Washington, and its working associates in every State and Territory in the Union, for the collection and diffusion of useful knowledge. Our sympathies are with all sincere and active friends of improvement, no matter where they reside; and we can not but believe that these noble spirits will ere long co-operate most effectively in all the States, to increase the learning, cultivate the taste, improve the practice, and enlarge the views and science of American farmers. As a medium of communication between those who believe in rural instruction, and desire to improve, the *Genesee Farmer* offers many and peculiar advantages. It is published in a farming region sufficiently advanced to sustain an agricultural journal years before the *Albany Cultivator* was started, at twenty-five cents per annum. In successful agriculture, horticulture, and nurseries, Western New York has attained a degree of maturity and excellence which we have sought in vain elsewhere on this con-

tinent. Our cheap periodical is a *help* to other agricultural papers, not a competitor. They have started into existence after it. This pioneer publication, and its patrons of a quarter of a century, have created a demand for agricultural reading, and a score of new journals are profiting by it. We wish them all success; for there are still hundreds of thousands, nay millions, that read no similar work, and affect to despise all book knowledge.

Whatever discoveries are made in rural arts and sciences in Europe or this country, will be sure to receive an early notice in this journal. Congress has printed and ordered printed three hundred and ninety thousand volumes of the agricultural books prepared by the writer in the Patent Office; and we have given in the *Journal of the United States Agricultural Society*, many months in advance of Government, the agricultural statistics of every State and Territory, as taken at the last census, and corrected at the Census Office down to July 22d of this year. These official tables will be found in the present number of the *Farmer*. If each subscriber, in ordering this paper for 1853, will induce his friends and neighbors to add their names to our list, both they and the editor will be benefitted, as well as the farming community.

So far as time and ability will permit, we shall be happy to answer all inquiries that our readers may please to make, without charge; as we shall be thankful for every item of knowledge either in husbandry or horticulture, adapted to the character of this paper, and not already sufficiently known.

Now is the time to subscribe for the coming year; for our terms are strictly pay in advance; the profits being only a few cents on each volume of the work.

WHEAT CULTURE.

AFTER noticing the unprecedented drouth that has prevailed in central Illinois the past season, Mr. A. STEVENS, of Peoria, says: "I have read your articles on the culture of wheat, with great satisfaction; and I hope that you will continue the subject until the raising of that grain, though not a new business, shall be better understood by western farmers at least, than it ever has been even by the most practical and intelligent of them."

The two most common defects in wheat culture at the west, are the use of impure seed, or sowing clean seed on foul land, and a total disregard of the essential elements of the crop, which ought to abound in the soil to secure a profitable harvest. As a question of economy, the annual loss that accrues from the use of bad seed, and the propagation of pestiferous plants and weeds, should be pondered, not only by every wheat-grower, but by every other person who cultivates so much as a rood of land. Carelessness in this regard is a distinguishing feature in American tillage, whether on a wheat farm of a thousand arable acres, or in a small village garden. Some of our New York, New England, and Pennsylvania readers, will regard this remark too severe; but their better system of farming is only an exception to the general rule, which may be seen in all its deformity in the western, southern, and middle States. It is rare indeed that one meets with a field of wheat in Virginia or Maryland that is entirely free from garlic, the seeds of which damage the crop from five to twenty per cent. of its value. A volume might be written on the injury done by weeds, and the best means of extirpating them, without exhausting the subject. Clean land and pure seed are elements of profit in wheat culture, and agriculture generally, that we can not too often nor too earnestly commend to the attention of our readers. But neither clean land, nor pure seed, nor deep and thorough tillage, will long make wheat-growing profitable on the same fields, unless the raw material consumed and wasted in the processes carried on

is clearly understood by the farmer. The extreme reluctance with which cultivators study the elements of fertility in their soils; investigate the chemical changes wrought in the surface of the earth by the operations of plowing, harrowing, and hoeing; and consider the food of their living, growing crops, as actually consumed; compels us to view with some alarm the agriculture of the country. Our present system often takes one hundred times more of the precious atoms that form wheat and corn, tobacco and cotton, out of the surface of the earth, than is restored to it again. But our western friends will not now consider the damage that may be done to their newly improved farms; and therefore we need not waste time in writing, nor room in our journal, by urging them to husband ammonia, bone-earth, potash, soda, chlorine, magnesia, and gypsum, as the ingredients which nature has stored up in their virgin soils, not to be wasted by the two or three first generations that may chance to till them. Conceding what is not true, that wheat-growers have a moral right to exhaust the land of its elements of bread and meat, for exportation, we tell them that the free use of lime will render the natural resources of arated land more available to wheat plants. On all fields in which calcareous matter does not abound, and the phosphates and sulphates of iron and alumina do, lime may be used with decided advantage. In such cases, lime abstracts both phosphoric and sulphuric acids from iron or alumina, forming the phosphate of lime and gypsum, both of which improve the soil. To keep up the fertility of wheat farms, no practice has been so successful as the culture of clover, peas, corn, roots, and grass, in rotation with wheat; taking care to return in manure, or green herbage, the elements contained in these renovating crops.

Too much wheat is grown in the United States, and the price of this great staple is too low for the public good. Millions of bushels are raised every year, and sold for a sum of money that will no more than purchase, in any market, the raw material consumed and lost in making the grain. The business would be universally abandoned at present prices, but for the fact that the intrinsic value of the things in the land, which contribute so largely to form the harvest, is rarely estimated by the husbandman. To prevent the slow but unceasing impoverishment of the soil, more manure must be made, and what is made must be better husbanded, and used with greater skill. No arbitrary rules can be given that will apply to all climates, and all conditions of land; but much must be left to the sound judgment of the cultivator after he has been taught the true principles of his profession. Wool-growing and meat-making may be associated with wheat-culture with decided advantage. In producing a needful supply of manure, by the consumption of grass, hay, coarse grains, roots, and oilcake, so necessary to enrich all tilled land, the farmer may realize a fair income from his sheep. In short, our western friends should combine legitimate husbandry, *i. e.*, stock-raising and wool-growing, with tillage, or agriculture proper.

Nor should the hidden resources of the subsoil be forgotten in this brief survey of the art of producing wheat at a profit. If the elements of bread which a good Providence has placed in the subsoil are to be dug out over millions of acres, and sent by railways, canals, rivers, lakes, and the ocean, to distant cities, and there *wasted*, we prefer to say nothing of deeper plowing — nothing that will compel the next generation to give twice as much hard work for a bushel of wheat or corn as the people of Illinois now give. Posterity has done us no harm; and we will never knowingly aid in the unjust work of desolating one cultivated field from which those that are to come after us may wish to draw their indispensable food and raiment. They shall have the arable lands of all the grain and cotton-growing States of this Republic as rich in every respect as God made them, so far as our humble pen and tongue can secure that consummation.

THE WANTS OF SOCIAL AND DOMESTIC LIFE.

IN the eagerness of our pursuit of the almighty dollar, how prone we are to forget the wants, and neglect the duties of domestic life. How often do we see that peace of mind which money can not buy, and all that wealth is permitted to purchase, thoughtlessly sacrificed to accumulate riches, never to be enjoyed by their nominal owner! Such folly deserves a word of rebuke at our hands, if the social and domestic wants of one or two hundred thousand readers have any claim to our friendly regards.

Of all useful arts and sciences, that Domestic Economy which teaches the wisdom of extracting much happiness from small means, best deserves our study; for it best rewards the practice of the community. Wisdom of this kind makes slow progress, not because a higher standard of social and domestic comfort is unattainable, but from the force of habits, handed down to us from an age of semi-barbarism and extreme poverty. So numerous and important have been the discoveries and inventions during the first half of the present century, that the mass of mankind have yet to learn the proper use of the new treasures placed within their reach. Nor is it an easy task for the head of a family to decide how he can make the most of the property and knowledge that legitimately belong to him. What shall he do? and how shall it be done?

In cities, thousands die of pestilence and other maladies of their own creating, from the neglect of cleanliness, and defective sanitary regulations. In the country, thousands work hard, fare hard, and die poor, not from any necessity, but because the knowledge and social culture which they most need are sadly overlooked and unappreciated. It is the glory of our free institutions, that the poor are rich enough, under wise instruction, with industry and economy, to have of their own, healthy and comfortable homes. Too many, however, make no adequate effort to rise in the scale of humanity; and some words of encouragement, some cordial to their feeble self respect, must be administered before they will begin to labor for their own good. Their domestic wants are in embryo; and the public authorities should see to it, that they are developed aright, securing equal justice and advantages to the physical, moral, social, and intellectual man. Although he, while in his lowest estate, may not know how to unfold the germs of good that his Maker has planted in his constitution; yet, wiser heads than his may successfully cultivate the barren soil within him. The African race has long been regarded as the most stupid of the descendants of Adam. Whether this be so or not, no one now denies that this race is capable of civilization, and indefinite improvement. When viewed in their proper light, the social habits and domestic wants of man are seen to be elements of great power. In skillful hands, these elements will form the basis of a sound public opinion, and prepare the way for the abatement of vice, and crime, and suffering to a degree now little dreamed of in our narrow philosophy.

In society as in geology, there are many strata. We have briefly alluded to the lowest, and proceed to invite attention to those above—to such as have dwellings of their own, but with broken windows, leaky roofs, badly fitting doors, and a scanty supply of fuel for warming them in the winter now close at hand. Shall these domestic matters be attended to, or not? That is the question. Is the reader a good economist? then be assured that discomfort is often more expensive than the full measure of enjoyment in the domestic circle. It is true that no inconsiderable folly is perpetrated under the influence of fashion, and a mistaken notion of what constitutes true taste and sound sense in rural architecture, household furnishing, landscape and farm improvements. A word of caution may not be amiss, to check extravagance, and prevent disasters, in this direction.

Great prosperity is always perilous. Society is already full to overflowing of pride, conceit, hypoeraey, and extravagance. These are the bane of quiet domestic happi-

ness, and the curse of social life. Far be it from us to countenance this quackery of upstart wealth, whose ephemeral brilliancy dazzles but to blind and ruin its votaries. To call into existence in the bosom of a family, far more wants than can reasonably be gratified, is an evil and a wrong of great magnitude. Such improper wants suggest, and ever prompt, improper actions. Engagements are entered into that can not well be fulfilled; and speculations follow of a more reckless character. True social wisdom carefully avoids the temptations that beset the path of virtue. To the spirit of rivalry and ambition there is no limit. If nine-tenths of the community lived in marble palaces, the other tenth might die of disappointment if they failed to erect palaces made of polished ivory, and covered with plates of pure gold. In such a strife, where is the wit, the taste, the science, or the happiness?

We must go back to the simplicity of nature, and the truthfulness of science, if we would elevate and improve society. It can never be done by humbug. The country is overrun with quacks of every degree—quack statesmen and quack philanthropists, quack editors and quack clergymen, quack doctors and quack lawyers, quack authors and quack artists. All these wax fat at the public expense; and quack publishers are beginning to share very liberally in the spoils. It is the artificial wants of the community that sustain all these charlatans; and it is difficult to discover at what point in our social progress the pleasure of being cheated is to stop. A strong love of morbid excitement pervades the very heart of society, and grows on what it feeds. The most trashy and corrupting books make fortunes for the manufacturers and writers; while works of solid merit and of a purifying tendency, find comparatively few purchasers, and starve their authors. These may be unwelcome truths, but they are important truths nevertheless.

BEAUTY AND VALUE OF FOREST TREES.

"The goodliness of trees when we behold them deliteth the eye."—*Richard Hooker. Born just three hundred years ago.*

No people have more reason than the Americans to admire "the goodliness of trees;" and yet, in no country are they more rudely assailed as the enemies of civilization, and objects worthy of extermination by the ruthless axe and the consuming fire. Such semi-barbarism is discreditable to our national taste, our common sense, and our foresight in other matters of smaller moment. Trees abound in the elements of beauty which may be combined in a thousand pleasing forms. Their culture enables the skillful artist to paint his landscape in living verdure—to present to the eye, open fields and shading groves, wood-crowned hills and sun-lit vales, in charming contrast. Without trees, the world would be a desert; with them, it can be made a paradise. They temper both heat and cold, prevent the injurious dryness of the atmosphere, and greatly promote the fall of genial showers and seasonable rains, in spring, summer, and autumn. For wood, timber, lumber, staves, and a thousand uses, they are almost invaluable.

Forest-culture, considered as a science and an art, is destined to become extremely popular in the United States. The boundless area of fertile lands in this country, the admirable adaptation of its soil and climate to the growth of magnificent trees, and the production of incomparable orchards, and the rich rewards that will recompense the labor and capital devoted to this department of agriculture, can not fail to render it the favorite pursuit of millions.

The season for collecting the seeds of oaks, walnuts, beeches, and chestnuts, is at hand. Some of these, sent to the continent of Europe, and put up under our direction, have preserved their vitality, and are now growing up honored specimens of American forest trees. Extracted from the burr as soon as ripe, none of these seeds should be

allowed to become perfectly dry. We box them up in natural earth which is neither dry nor wet. First put in a layer of earth an inch or two in depth, according to the distance the seeds are to be conveyed, and then a layer of acorns, walnuts, chestnuts, beechnuts, or other seeds. This is to be covered with more loose earth, which is to serve as the bed for another layer of nuts; and in this simple manner a box or cask may be filled, and put in order for transportation. Nuts of the tea tree are extremely liable to become rancid and have their germs killed. The buds on the rattoons of sugar-cane used in planting, suffer in a similar manner, as we have seen in the agricultural department of the Patent Office. To preserve the vitality of seeds and buds, is an object of great importance.

Seeds of our native trees are in demand for exportation; and we respectfully commend this whole subject to the attention of our readers. In no other way can they so cheaply embellish their farms, and add to their attractiveness and value, as by improving their woods, groves, and forests, and planting all the choice varieties of American trees on any spare ground not needed for cultivation.

WINTERING CATTLE AND HORSES.

OWING to the great drouth the past summer, in many parts of the country, winter feed will be exceedingly scarce, and the most rigid economy will be necessary to enable many farmers to carry their ordinary stock through the winter. What is the cheapest method of wintering cattle, sheep, and horses? always an interesting question, becomes now a most important one; and though we by no means pretend arbitrarily to answer it, yet we will endeavor to throw out a few hints that may be useful. We would premise that no particular method can be laid down, that will be applicable to all cases; the climate, locality, nature of the crops grown, and prices obtained for them, interfere with any such calculations. A more serious drawback, however, is the deplorable ignorance of us all on the subject of nutrition; for were the principles of nutrition well understood, it would be easy to alter our modes of feeding to suit circumstances, and so keep the animals in the best and most economical manner.

Different breeds of animals doubtless require different amounts of food; yet, as a general rule, it may be stated that animals require an amount of food in proportion to their weight. That is to say, an animal weighing 1200 lbs. would require twice the food per week as one weighing 600 lbs., other things being equal. More food, too, is required in cold than in temperate weather—more when the animal is worked than when doing nothing. Also, cows giving milk or when in calf, and young animals, require more than an animal of the same weight in a perfectly normal state. If, too, we wish an animal to lay on fat, we must give more food—or rather the same quantity or bulk of food, but of a more nutritious quality—than would be necessary to keep it in a normal condition, or without increasing or decreasing in weight.

The amount of food necessary per week to keep an animal in a normal condition under the most favorable conditions of warmth, is not accurately ascertained. The amount of food, however, which animals eat when given *ad libitum*, depends to a great extent on the per centage of *available non-nitrogenous* substances it contains, and not on the nitrogenous. Thus, an animal fed on oilcake, peas or beans, and clover hay, will eat nearly three times as much nitrogen as when fed with corn meal, hay, &c., though it is probable that the amount of available non-nitrogenous substances eaten, is pretty much the same in either case. The advantage, therefore, in feeding a highly nitrogenous substance, is not in the less amount required by the animal, but in the increased value of the manure and the increased quantity of fat a given amount of non-nitrogen-

ous food will produce, when eaten in conjunction with nitrogenous substances. We are, however, by no means to suppose that the *rate of increase* is in *exact proportion* to the per centage of nitrogen in the food, for it is not; *rapidity* of increase being attained only at an increased proportional consumption of nitrogenous substances.

By *available* non-nitrogenous substances, we mean such substances as sugar, starch, oil, gum, &c., which are readily dissolved in the stomach, and easily assimilated; and not such substances as woody fibre, which, though a non-nitrogenous substance, and composed precisely of the same elements as sugar, &c., is not available as food, being incapable of solution in the stomach, and is passed through the body of the animal unchanged.

In providing our store stock with food, especially in a season of scarcity, our object will be to give them a sufficient amount of available non-nitrogenous substances in the least expensive form. That is, leaving out every other relative question, such as value of manure and increase of animal, and aiming only at keeping the animals in a normal condition without work, we should prefer those foods, the price being the same, which contain the most sugar, starch, &c., supplying the necessary bulk with some cheap substance, such as straw.

The prices of some of the substances used as food for cattle, taking Rochester wholesale prices as the basis of calculation, will be an indication of the value practical farmers put upon them. We give the price per ton; for it is weight, and not bulk, that we desire in purchasing food, or in estimating its value.

Bran, at 7 cents per bushel of 10 pounds,.....	\$14 00	per ton.
Shorts, at 9 cents per bushel of 14 pounds,.....	12 55	"
Coarse middlings, at 14 cents per bushel of 20 pounds,.....	14 00	"
Fine " at 20 cents per bushel of 27 pounds,.....	14 07	"
" " at 30 cents per bushel of 34 pounds,.....	17 64	"
Indian corn, at 60 cents per bushel of 60 pounds,.....	20 00	"
Oats, at 35 cents per bushel of 32 pounds,.....	23 75	"
Oilcake,	20 00	"

Had we complete analyses of these substances, it would be easy to decide accurately which would be the cheapest food for our purpose. We have no doubt, however, that Indian corn contains much the most *available* non-nitrogenous matter, and that 100 lbs. of ground corn meal mixed with the required bulk of cut straw, will be of more avail in sustaining animal life during the winter than any other food that can be obtained at the same price. We have no doubt, too, that horses can be kept in the same way, at a much less cost than feeding them hay. If, however, they be worked much during winter, they would require a more nitrogenous food, to supply the wear and tear of muscles, and a little oilcake meal, pea meal, or oat meal, might be mixed with the cut straw, &c., — instead of, or in addition to the corn meal — with advantage.

BOUSSINGAULT estimates, from experiments and chemical analyses, that 100 lbs. of good meadow hay may be replaced by

Bran,	85 pounds.	Peas,	27 pounds.
Oats,	68 "	Potatoes,	250 "
Barley,	65 "	Carrot,	852 "
Maize,	50 "	Wheat straw,	426 "
Rye,	77 "	Oat straw,	853 "
Linseed cake,	22 "	Barley straw,	460 "
Beans,	23 "	Pea straw,	64 "

If this table of equivalents can be relied upon, it appears that 100 lbs of hay is equal to 426 lbs. wheat straw, and that 22 lbs. of oilcake is equal to 100 lbs. of hay, 68 lbs. of oats, 58 lbs. of bran, &c., &c. BOUSSINGAULT found that his 17 horses, averaging 1,070 lbs. in weight, eat and did well on a ration of 33 lbs. hay per day, working eight hours regularly every day. To obtain the same amount of nutritious food in straw, a horse must eat 165 lbs. of straw per day — a feat he is incapable of performing: but if we give him 30 lbs. of straw, equal to 6 lbs. of hay; 5 lbs. oilcake, equal to 22 lbs. of hay; and 3 lbs. corn meal, equal to 5 lbs. hay; he will receive the same amount

of nutritious elements, and in about the same bulk, while the cost of wintering him in this way would be considerably reduced.

By carefully studying the price of substances used as food, and their relative value, most farmers may save considerable expense in keeping their animals, not by stinting them, (no farmer can afford that,) but by using that food which contains the most nutriment for a given cost.

FATTENING CATTLE AND SHEEP IN WINTER.

THE necessity of manuring the soil by natural or artificial means, before the maximum produce can be obtained, is now all but universally admitted; and whatever difference of opinion exists as to the best means of obtaining and applying manure, all agree that it must be obtained and applied in some way or other, or the soil will gradually become impoverished and incapable of profitable cultivation. In some localities it may be good economy to increase and preserve the fertility of a soil by purchasing *artificial* manures, depending principally on them, and selling off the farm nearly all the produce, and so making no manure by stock. For this purpose, good Peruvian guano, at two and a half cents per pound, is decidedly the cheapest and best artificial manure at present offered for sale. But the great body of farmers can not purchase artificial manures; neither would it pay them if they could; their chief reliance must be on the manure made during the winter months, by cattle, sheep, and other stock, consuming produce grown on the farm. A consideration, therefore, of the effects produced by feeding a given amount of produce on a farm, can not fail to be useful and interesting to every farmer. There are many scientific matters connected with such an inquiry, which it would be interesting to us and to some of our readers to discuss; but at this time we must confine our remarks to the vital question — Will it pay?

In the July number, page 205, we gave the results of some valuable experiments instituted by the Worcester Agricultural Society, Massachusetts, in regard to the economy of cutting food for stock. From the same experiments we have arranged the following table, which shows the amount of hay consumed weekly by each 100 lbs. live weight of animal, the weekly increase of fat, &c., upon each 100 lbs. live weight, and the amount of increase which *one ton of hay* will produce. The bottom line shows the mean live weight of the animals with which the trials were made:

	C. E. DEMOND, Dry Cows.	HARVEY DOBIE, Steers.	W. S. LINCOLN, Milch Cows.	A. H. HAWES, Working Oxen.	BOUSSINGAULT, The mean of nu- merous experiments.
Hay, or its equivalent, consumed per week by each 100 lbs. live weight of animal,..... }	17.07 lbs.	13.50 lbs.	13.35 lbs.	16.50 lbs.	21.50 lbs.
Increase of animal per week upon each 100 lbs. live weight of animal,..... }	0.84 lb.	0.73 lb.	1.11 lbs.	0.91 lb.	1.87 lbs.
Increase of animal for <i>one ton</i> of hay consumed,.... :	93½ lbs.	106 lbs.	122 lbs.	108 lbs.	100 lbs.
Mean weight of animal,.....	892 lbs.	1110 lbs.	900 lbs.	1567 lbs.	748 lbs.

There is remarkable uniformity in the results obtained by the four New England experimenters, both in regard to the quantity of food consumed per cent. of live weight

of animal, and the *increase* obtained upon each 100 lbs. of live weight, and consequently in the weight of meat produced by one ton of hay. The last column is the mean result of many experiments as given by BOUSSINGAULT. The amount of food consumed per cent. of live weight is more than double any of the others, and so is the increase per cent.; so that the weight of beef produced by the consumption of one ton of hay, is nearly the same throughout the series; and we may safely take the mean result as a pretty correct indicative of what we shall obtain in common practice. The mean of the whole of the experiments is 106 lbs. of increase (which we shall consider as fat and meat) for each ton of hay consumed. From this it is evident that, in most places, feeding cattle in winter is attended with direct loss, or at least with no profit. How far the value of the manure may compensate for this loss, we shall inquire further on.

In some extensive experiments on sheep feeding, Mr. LAWES found that South Down sheep eat, per 100 lbs. live weight, 5 lbs. 2 oz. American oilcake, and 16 lbs. 2 oz. of clover hay per week; and increased 1 lb. 3 oz. Another lot eat per 100 lbs. live weight, 5 lbs. 2 oz. linseed, and 14 lbs. 12 oz. clover chaff; and increased 1 lb. 1 $\frac{3}{4}$ oz. per week. In the first experiment, 436 lbs. of oilcake and 1,378 lbs. of clover are required to produce 100 lbs. of increase. In the second, there is required 465 lbs. of linseed and 1331 lbs. clover hay to produce 100 lbs. increase. The 436 lbs. oilcake, at \$20 per ton, would cost \$4.36; the 1,378 lbs. clover hay, at \$6 per ton, would be worth \$4.14; making the cost of producing 100 lbs. of mutton, \$8.50—or eight and a half cents per pound.

From these facts it is most obvious that if feeding is a paying business, it is in the value of the manure made by it, and not in the mere production of beef, mutton, or pork. The whole question, then, of the economy of feeding cattle in winter, appears to rest on the value of the manure made in producing 100 lbs. of meat. To answer this question satisfactorily, requires much more data than we at present command. There are, too, many points involved in its settlement that are much disputed. Under such circumstances, therefore, we submit our own views, believing that they will ultimately be found not far from the truth.

In the first place, it is necessary to have some standard manure, the value of which is fixed, to compare with that made by feeding with different substances. For this purpose we know of nothing better than Peruvian guano, the consumption of which is now very great, and is steadily increasing. Its retail price is \$2.50 per hundred. A first rate sample contains 16 per cent. of ammonia, and 25 per cent. of phosphate of lime, &c. The phosphate of lime is worth about one cent per pound; for it can be purchased for that in other forms, such as animal charcoal. Therefore, the price paid for ammonia in guano is nearly 16 cents per pound, and we know of no cheaper source of it. The hay used in the experiments given in the table, was what is called "English meadow hay." It contains about 1.2 per cent. of nitrogen, or *one ton would contain twenty-four pounds nitrogen*. We may estimate the amount of *ammonia* in the excrements to be equal to the amount of *nitrogen* consumed in the food. Therefore, in consuming one ton of hay by cattle, we get 106 lbs. beef and 24 lbs. of ammonia in the manure, worth, at sixteen cents per pound, \$3.84. The ton of hay, too, would contain 14 lbs. phosphate of lime; and estimating that 3 lbs. phosphoric acid are retained in the increase of animal, would leave 8 lbs. phosphate of lime in the manure. This, as we have said, is worth 8 cents. If we call the potash, soda, sulphuric acid, &c., worth eight cents more; we get, in consuming one ton of hay on the farm, by horses, cattle, or sheep, \$4 worth of manure. The 106 lbs. of beef, at 5 cents per pound, is \$5.30. Adding the \$4 worth of manure, makes the return for one ton of hay, \$9.30.

With these data, any farmer can tell whether, in his locality, it is preferable to sell the produce or consume it on the farm—it depends on the relative price of hay and meat.

If oilcake and clover hay be used as food, the manure will be much more valuable than where hay only is eaten. Thus, taking the results of Mr. LAWES above quoted,

we have, to produce 100 lbs. of mutton, 436 lbs. oilcake, which contained 21.84 lbs. of nitrogen, and 1,378 lbs. clover hay, containing 29.08 of nitrogen — making in total food consumed to produce 100 lbs. increase, 51 lbs. of nitrogen. According to our former estimate, this would give 51 lbs. of ammonia in the manure, and, at 16 cents per pound, would be worth \$8.16. The oilcake, too, would contain 8.72 lbs. phosphoric acid, the clover hay 6.24 lbs. This, estimating 3 lbs. as taken up in the 100 lbs. increase, would leave about 24 lbs. of phosphate of lime, &c., in the manure, worth 24 cents. If we allow 10 cents for the potash, soda, &c., the value of the manure made in producing 100 lbs. of meat with oilcake and clover, will be \$8.50. This, it will be seen, is exactly the value of the food eaten, reckoning the oilcake at \$20 and the clover hay at \$6 per ton; so that we get the 100 lbs. increase of animal for nothing, except the labor of attending the animals.

From these facts, which are undoubtedly true in their comparative character, we conclude that while it is of questionable economy to feed hay to cattle in winter, the production of meat by oilcake and clover chaff is attended with considerable ultimate profit. There are probably no other substances used as food, that would give so good a result; clover containing more nitrogen than meadow hay, or any of the different kinds of grasses, and oilcake is perhaps the most highly nitrogenous substance used as food by herbivorous animals. Beans, peas, and lentils, approximate closely to oilcake in their per centage of nitrogen; and their growth and consumption on the farm can not be too highly recommended, or be too extensively adopted by all farmers. Even admitting that, weight for weight, the cereals wheat, rye, oats, barley, and maize, are as good for feeding purposes as the leguminous seeds beans, peas, and lentils, or as oilcake, (which, however, is by no means the case,) the manure made from them would not be half so valuable; and, as we have shown, it is to the value of manure that we must look to make fattening stock a profitable business. Leaving the value of the manure out of the calculation, feeding is in most cases attended with direct loss: reckoning the value of the manure, and feeding with oilcake, beans or peas, and clover hay, it is attended with considerable profit.

Many will be inclined to object to these conclusions. We submit them, however, hoping that they will not be cast aside with a careless perusal, but be thoroughly investigated, when we think their justness will be evident. At all events, if they lead to thought and an examination of the matter, some good will be accomplished. The value of manure we have estimated according to the present price of guano. The subject is a deeply interesting and important one to every cultivator of the soil.

PREPARE FOR THE STORM.—Winter is now fast approaching, and of course all our readers have made preparation to give him a warm reception. The necessity for this is so apparent, that but few perhaps neglect it in the main; yet how many there are who, when the cold weather is really upon them, have cause to regret that some things have been left undone that should have been done. They then resolve that the next winter shall not find them in so unprepared a condition. The next winter they repeat their good resolves, and try to satisfy a troubled conscience, and thus the matter ends for a year. To such—to all—we say, look about your premises,—your house, and barn, and stables,—and see what more you can do, even if it is not absolutely necessary, to make more comfortable yourself and family, and all living creatures that look to you to protect them from the winter's blast; and to save from injury the crops you have stored, and which you proudly look upon as the result of your summer's toil. Do your work up thoroughly in this respect, and you can enjoy the winter's fire, the visits of your friends, the reading of your agricultural papers with a peaceful conscience, laugh and grow fat, and come out in the spring with new life and energy for another season of labor.

IMPROVEMENT IN FARM GATES.

WE have been furnished by Mr. ENOCH WOOLMAN, the inventor, who resides near Damascusville, Mahoning county, Ohio, with the accompanying engraving and description of his improvement in farm gates. We understand that a number of them have been introduced in the neighborhood where the patentee resides, and that they give good satisfaction.

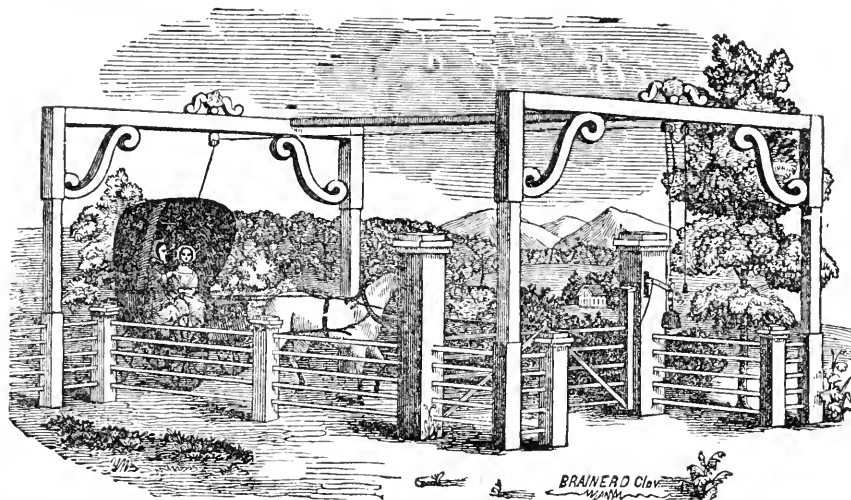

"The principal improvement consists in its being so constructed that a person in a carriage or on horseback, can pass through it without alighting. On approaching from either way, the person takes hold of a rope, which hangs over the center of the road, and pulls gently for a short time, and the gate comes open and fastens itself; and then in driving a carriage or wagon through, one of the wheels runs over a trigger fixed on the ground, which unfastens it, when it immediately shuts and fastens itself again. The only difference in passing a person on horseback is this: In pulling the rope to open the gate, care must be taken not to pull it far enough to allow it to fasten itself; but by pulling it about two-thirds of the way open, the horseman can easily pass through before it shuts itself again. The machinery by which these movements are performed, is simple, and not liable to get out of repair; and the whole structure is substantial and durable, and will, no doubt, commend itself to the favorable notice of those for whose convenience it is intended. A model of this gate was presented for examination at the World's Fair in London, and received from the committee a very favorable notice."

Nothing adds more to the appearance of a farm, or is of more convenience, than good farm gates; and while we are not prepared to recommend this gate for the adoption of farmers, we are prepared to say to all, see that you have good gates wherever convenience and safety require them. Many will prefer having them made by mechanics, while others can well employ their leisure time in winter in making them; and if a few more are made than is thought necessary, they will not come amiss. Every farmer should have a few common tools, and a workshop, where he can employ himself usefully on a rainy day. We have known farmers — and so have you, dear reader — who made all kinds of miserable shifts for gates, using bars and many other inconvenient contrivances, and yet who lounged away enough time every year to furnish each field with a good gate. This, perhaps, is the result more of thoughtlessness than indolence. If no shop and no tools are prepared, a person can easily excuse himself; but when shop and tools are all ready, inviting to work, few men are so indolent as not to accept the invitation. Therefore, get a few good tools, and prepare a little workshop, and the work is more than half done.

Condensed Correspondence.

MULCHING POTATOES.—Last spring I tried a small experiment on potatoes, and am so well satisfied with the result that I shall try it on a larger scale next year. I planted and covered my potatoes as usual, but on one part of the field I covered the land with straw about six inches deep. We dug the potatoes last week; those on the covered land were much larger and yielded better than those not covered. One of the potatoes on the covered part weighed 2 lbs. 5 oz. The covered ones were much easier dug, and we save the labor of hoeing. I used wheat and oat straw, but suppose any refuse straw will answer. L. MORRIS.—*Windsor, Asht. Co., Ohio.*

A SINGULAR FACT.—In the spring or summer of —, a neighbor of mine put into his pen a very large hog, desiring to feed him until the following January. He was fed on corn meal and the refuse of the kitchen, from a common large trough in which, after eating, he would lie. In the month of August his appetite failed him and his growth seemed arrested. He was, however, carefully fed until the last of September, when finding he was not improving he was slaughtered, and on examining his stomach it was found to contain a large ball of hair resembling in size, and somewhat in shape, a goose egg, and so tightly knit together as to be separated only by application of the axe. C. P. RAMSBELL.—*Venango Co., Pa.*

OREGON PEAS, &c.—Enclosed please find a small package of the Oregon Pea, lately brought from that country. It is remarkable for its productiveness of both vine and pea, is said to make the best of hay in large quantity on poor land, bears till frost, will lie on the ground all winter without rotting, and is excellent for table use. It is small, but grows in bunches so that you can gather them very fast, say from ten to twelve pods at a grasp. It is not a climbing pea, and has a stalk greatly resembling our cotton. For pasturing, it would be very fine; also for manuring land by plowing under. It should be planted early.

I have raised the China corn this year. I got it from Kentucky. It produces a great deal of grain and fodder. I think it is the same as the Doura corn. It brings from ten to eighteen heads to the hill; the first heads were ripe the second week in August. It is still bearing, and I think will not stop until cold weather. I will send you a package, if you want it, without charge. A. H. BRADFORD.—*Brownsville, Tenn.*

We will plant the peas early next spring and report the result. Shall be pleased to receive a few grains of the corn.

WOOLEN RAGS AS MANURE.—As a fitting return for your trouble in answering my inquiry in the May number, in regard to the application of Woolen Rags as a Manure, I now send you the result of my so doing. In my former letter I said nothing about the quality of the land I intended planting. It was a light yellow sand, and had been cropped with wheat the year previous and sowed with clover, which had not, however, taken well. I planted the piece, just one-third of an acre, part on the 10th of May, and the other part about the 20th, in rows three feet apart, putting the sets one foot apart. They would, I think, have produced more if only eight or nine inches apart. I first drew the rows, and then, after cutting them up, scattered the rags, at the rate of one ton to the acre, dry, in just the state I saved them, in the rows and dropped my sets *on the rags*, covering them up in the usual manner. I hoed them three times, and the product is just $75\frac{1}{2}$ bush. of the largest and best Pink-Eye potatoes I ever saw. The rags now appear but little decomposed. I purposely left two rows without rags; the difference in the appearance of the potatoes during their growth, and in the quality and quantity of the product, was very striking. I have just formed a manure heap, as follows: first, a layer of horse dung and litter; then a layer of woolen rags; then a layer of spent lime; then another layer of rags; continuing thus to the top, on which I put a heavy coat of the same as at the bottom. With it I intend dressing my garden in the spring. The piece on which I used the rags the present year, I intend again to plant with potatoes next year. J. C.—*Toronto, C. W.*

Such a heap needs a covering of loam or garden mould to retain the ammonia liberated by the lime from the decaying rags and dung.

PRODUCTIONS OF AGRICULTURE IN THE UNITED STATES.—SEVENTH CENSUS.—1850.

STATES.	Acres land improved.	Acres land unimproved.	Cash value of Farms.	Value of machinery.	Horses.	Asses & Mules.	Mitch.	Work- ing Oxen.	Other Cat- tle.	Sheep.	Pwine.	Value of Live Stock.	Wheat, &c. bushels of.	Rye, &c. bushels of.	Indian Corn, &c. bushels of.
MAINE	2,039,536	2,515,737	\$4,851,748	2,284,554	41,721	55	133,556	59,893	125,890	431,577	54,528	9,705,726	296,259	102,916	1,750,057
NEW HAMPSHIRE	2,251,488	1,140,936	5,253,997	3,143,125	34,253	19	94,277	50,027	114,605	384,756	63,487	8,871,901	185,658	183,117	1,573,455
VERMONT	2,591,379	1,525,308	59,757,731	27,900,227	61,025	218	146,146	43,497	154,025	919,992	66,278	12,610,925	525,925	176,297	2,662,916
MASSACHUSETTS	2,133,435	1,222,576	109,076,731	3,299,584	42,216	34	130,009	46,611	83,884	188,651	81,119	9,619,210	31,221	481,027	2,315,169
CONNECTICUT	3,366,478	197,181	17,070,802	4,957,201	6,158	1	25,698	8,139	9,575	41,296	19,509	7,457,637	9,575	26,409	559,291
NEW YORK	12,408,478	6,110,020	554,345,632	22,084,929	258,781	49	85,461	46,839	89,225	174,181	76,472	7,457,499	41,762	600,893	3,935,013
NEW JERSEY	7,457,598	4,072,528	407,275,311	14,723,509	41,014	4,969	93,332	18,909	3,453,331	1,018,252	73,570,291	13,121,192	4,148,152	17,838,404	
PENNSYLVANIA	8,157,570	4,294,283	407,275,311	14,723,509	369,355	2,250	530,734	12,070	80,435	160,488	230,570	10,679,291	1,601,190	1,255,775	8,783,704
DELAWARE	550,982	375,982	18,800,030	510,270	13,852	720	19,272	9,257	182,857	582,357	1,040,556	41,500,033	13,667,691	480,516	19,835,213
MARYLAND	2,797,995	1,896,445	87,178,545	2,403,449	75,654	5,644	86,850	34,135	38,122	177,062	352,892	7,357,434	4,841,470	296,000	1,104,551
Dist. Columbia	16,297	11,187	1,730,460	40,320	824	57	813	104	699,137	1,310,004	1,830,712	33,656,659	11,292,616	455,020	35,254,310
VIRGINIA	15,792,176	15,792,176	216,401,441	7,021,772	572,409	21,450	317,619	86,513	669,137	1,310,004	1,830,712	33,656,659	11,292,616	455,020	35,254,310
NORTH CAROLINA	5,453,977	5,453,010	67,891,766	3,931,532	148,693	25,429	291,799	37,309	431,402	505,349	1,812,812	17,717,647	2,130,102	299,299	9,600,000
SOUTH CAROLINA	4,072,631	12,145,049	82,431,684	4,136,354	97,171	37,483	193,214	26,207	563,035	285,451	1,665,265	15,000,015	1,065,277	43,790	16,271,454
GEORGIA	6,378,479	16,442,900	95,753,445	5,891,150	151,331	57,379	324,223	73,286	690,019	560,435	2,168,617	23,752,416	1,088,531	53,750	30,080,999
FLORIDA	319,019	1,236,240	6,323,109	658,795	10,148	5,002	72,876	5,791	182,415	299,453	2,880,058	1,027	1,027	1,996,909	
ALABAMA	4,435,614	7,702,067	64,323,224	5,125,663	128,001	58,995	227,791	63,961	433,263	271,880	1,504,540	11,690,112	291,014	1,152	2,754,408
MISSISSIPPI	1,590,925	7,046,061	54,738,634	5,762,927	89,514	41,849	165,576	38,455	436,254	304,929	1,582,731	19,403,662	137,990	17,861	9,606,673
LOUISIANA	3,444,338	3,939,018	75,814,398	11,576,958	79,514	12,364	214,758	49,982	636,466	683,914	10,266,800	99,098	41,689	417	5,029,611
TEXAS	693,107	14,451,669	16,396,768	1,601,296	76,419	93,151	214,758	38,255	165,320	91,256	836,727	6,647,906	199,639	89,163	8,893,339
ARKANSAS	791,531	1,816,654	15,235,245	5,300,229	60,197	75,303	250,459	82,252	414,051	811,591	3,114,111	29,978,016	1,619,386	58,047	5,227,522
KENTUCKY	11,368,479	10,972,478	154,330,352	5,169,639	315,652	65,600	541,499	62,074	1,102,121	1,102,121	2,861,163	29,501,287	2,140,822	425,718	59,078,659
TENNESSEE	5,791,521	13,908,849	97,851,212	2,133,731	75,419	3,423	541,499	65,384	3,942,929	1,964,770	4,142,174	14,487,331	4,925,889	108,871	5,691,463
OHIO	9,851,493	8,146,000	358,738,000	12,700,555	383,307	70	99,676	40,221	119,471	746,435	2,203,847	8,008,734	6,214,458	52,879	22,144,320
MICHIGAN	1,929,110	2,451,780	51,872,446	6,701,414	314,239	6,309	284,531	53,250	889,891	1,122,493	2,263,846	23,209,528	2,203,846	6,214,458	10,871,362
INDIANA	5,006,543	7,449,879	136,258,123	6,701,414	217,629	10,573	322,531	70,150	541,209	894,043	1,913,910	24,209,528	2,203,846	6,214,458	13,112,458
ILLINOIS	2,092,545	6,297,897	69,168,290	3,376,935	297,625	41,908	229,536	111,238	443,616	541,209	1,692,943	19,706,581	2,203,846	6,214,458	13,112,458
MISSOURI	2,874,822	1,911,395	16,657,467	6,701,414	217,629	724	41,704	24,802	541,209	541,209	1,692,943	19,706,581	2,203,846	6,214,458	13,112,458
LOWA	1,045,409	1,991,159	28,528,673	1,617,569	20,719	1,661	61,200	4,750	92,550	139,276	3,353,785	4,257,328	1,401	1,401	2,203,846
WISCONSIN	62,324	3,831,571	3,871,011	103,482	500	11	11	11	740	740	740	740	740	740	740
CALIFORNIA	5,035	23,846	161,948	183,427	8,046	420	4,227	5,114	24,188	13,389	30,227	157,610	211,913	106	16,725
MINNESOTA	132,857	39,516	2,849,176	183,427	8,046	325	4,227	5,114	24,188	13,389	30,227	157,610	211,913	106	16,725
OREGON	16,333	311,799	311,799	81,292	4,227	325	4,227	5,114	24,188	13,389	30,227	157,610	211,913	106	16,725
UTAH	166,201	121,370	1,653,592	77,590	5,079	8,654	10,635	12,425	10,635	3,292	7,314	149,1529	196,546	210	303,411
NEW MEXICO	166,201	121,370	1,653,592	77,590	5,079	8,654	10,635	12,425	10,635	3,292	7,314	149,1529	196,546	210	303,411
IN EX. 178	181,506,025	329,629,537	151,600,447	3,335,632	559,070	6,391,916	1,698,261	10,265,150	21,620,459	30,315,719	543,822,711	1,004,792,150	14,188,457	392,141	230

PRODUCTIONS OF AGRICULTURE IN THE UNITED STATES.—SEVENTH CENSUS —1850.

STATES.	Oats, bushels of.	Rice, lbs. of.	Tobacco, bales of 400 lb. each	Ginned Cotton, bales of 400 lb. each	Wool, lbs. of.	Peas and Beans, bushels of.	Irish Potatoes, bush. of.	Sweet Potatoes, bush. of.	Barley, bushels of.	Buckwheat, bushels of.	Value of Orchard in Dol.	Wine, gallons of.	Value of Produce Market Gardens	Butter, lbs. of.	Cheese, lbs. of.
MAINE,	2,181,037				1,364,034	205,541	3,436,040		151,731	104,523	342,965	724	122,387	9,243,811	2,434,454
NEW HAMPSHIRE,	973,381	50			1,108,476	4,304,910	3,436,040		70,256	65,265	248,563	344	387,056	6,977,056	3,196,563
VERMONT,	2,307,714				3,410,933	40,859	4,947,351		42,137	208,099	310,943	639	18,553	11,871,451	7,729,834
MASSACHUSETTS,	1,165,106	138,346			585,136	43,769	3,885,384		12,388	106,095	403,995	4,688	600,020	8,071,370	5,729,542
RHODE ISLAND,	215,232				129,922	63,466	651,029		18,573	92,345	178,991	4,034	36,275	390,570	5,363,277
CONNECTICUT,	497,454	1,267,624			19,090	2,689,725	80	5,100	13,509	3,183,935	1,761,260	9,179	919,017	79,766,094	49,741,413
NEW YORK,	26,552,814	83,189			741,036	3,389,362	5,981,172	5,981,172	6,492,784	273,389	607,268	18,111	47,219	9,487,916	305,576
NEW JERSEY,	3,378,063	910			375,596	3,980,739	5,981,172	5,981,172	165,584	2,193,632	233,380	25,500	688,714	39,878,418	2,505,034
PENNSYLVANIA,	21,538,156	912,651			4,485,769	4,120	240,157	208,993	65,443	8,615	46,571	15	12,714	1,055,308	3,187
DELAWARE,	604,318				57,769	4,120	240,157	208,993	65,443	8,615	46,571	15	12,714	1,055,308	3,187
MARYLAND,	2,284,121				480,296	12,816	76,193	3,497	75	103,671	1,431	200,869	3,806,160	3,975	1,500
DIST. COLUMBIA,	5,131				535	7,754	29,292	3,497	75	103,671	1,431	200,869	3,806,160	3,975	1,500
VIRGINIA,	10,179,045	17,154	56,803,218	3,917	2,800,765	521,581	1,316,933	1,813,671	25,437	214,898	177,137	5,408	183,047	11,069,359	436,298
NORTH CAROLINA,	4,052,078	5,465,888	73,849		970,738	1,587,222	620,318	4,037,709	2,735	16,704	4,134	11,068	39,462	4,146,290	95,921
SOUTH CAROLINA,	2,322,155	159,930,613	74,255		300,901	1,026,900	136,494	6,967,469	4,583	283	35,108	5,880	47,286	2,981,850	4,970
GEORGIA,	3,820,044	38,950,691	423,924		490,091	1,142,011	227,379	6,968,428	11,501	250	92,776	796	75,500	4,610,559	46,376
FLORIDA,	66,586	1,075,090	998,614		45,131	135,359	7,828	757,226	55	1,280	10	220	8,721	371,498	18,015
ALABAMA,	2,965,697	2,311,252	164,990		892,701	246,001	5,475,294	3,938	318	15,408	220	84,821	4,008,811	31,412	21,191
MISSISSIPPI,	1,503,288	2,719,836	49,900		1,072,737	261,482	4,741,795	259	1,121	50,405	407	46,250	4,346,231	21,919	31,412
LOUISIANA,	89,637	4,425,349	178,737		199,897	161,732	1,428,453		3	15,605	39	18,329	683,069	1,957	9,619
TEXAS,	178,883	87,916	66,897		131,374	179,332	835,181	1,323,170	4,776	175	401,141	38	17,130	1,854,239	30,768
ARKANSAS,	656,183	63,179	218,936		182,595	285,798	1,933,832	788,149	2,737	19,427	32,894	9,093	86,780	9,479,683	177,684
LOUISIANA,	7,783,086	258,854	194,532		1,364,378	369,321	1,060,844	2,777,716	2,737	19,427	32,894	9,093	86,780	9,479,683	177,684
KENTUCKY,	8,201,311	5,088	55,501,196	738	2,297,403	202,574	1,600,844	2,777,716	2,737	19,427	32,894	9,093	86,780	9,479,683	177,684
OHIO,	13,472,742		10,445,149		1,936,371	40,998	1,827,769	998,184	35,368	63,667	132,650	14,651	11,738	7,065,878	20,819,542
MICHIGAN,	2,866,056		1,245		2,043,282	5,773	1,827,769	181,391	35,368	63,667	132,650	14,651	11,738	7,065,878	20,819,542
INDIANA,	5,635,014		1,044,250		2,043,282	5,773	1,827,769	181,391	35,368	63,667	132,650	14,651	11,738	7,065,878	20,819,542
ILLINOIS,	9,294,276		8,200	14	2,150,113	82,814	2,511,861	901,177	45,148	149,750	324,900	14,651	11,738	7,065,878	20,819,542
MISSOURI,	1,594,345	700	17,100,884		1,015,860	45,774	931,627	382,310	110,735	184,504	446,089	9,997	12,964	12,881,535	624,564
IOWA,	1,594,345	500	6,041		373,898	4,975	382,310	6,243	25,083	52,510	8,434	420	8,848	2,171,188	202,129
WYOMING,	3,414,672		1,298		253,963	20,657	1,402,077	6,243	25,083	52,510	8,434	420	8,848	2,171,188	202,129
CALIFORNIA,			1,000		85	2,292	9,292	1,000	9,712	79,876	17,700	58,055	75,275	705	150
MISSISSIPPI,	30,582		325		10,002	21,145	515	2,000	1,316	515	1,271	150	1,100	1,100	36,980
OREGON,	65,146		70		29,686	6,566	91,326	6	1,789	332	8,231	2,063	90,241	30,998	30,998
UTAH,	10,900		289		9,292	289	43,998	6	1,789	332	8,231	2,063	23,868	83,309	83,309
NEW MEXICO,	5		8,467		32,901	15,688	3	6	5	100	8,231	2,063	6,679	5,848	5,848
TOTAL,	146,533,216	215,312,710	199,730,746	2,486,625	52,518,143	9,219,642	65,747,171	382,581	5,167,213	955,945	720,862	221,219	5,270,130	312,948,915	105,539,289

PRODUCTIONS OF AGRICULTURE IN THE UNITED STATES.—SEVENTH CENSUS.—1850.

STATES.	Hay, tons	Clover seed bushels of	Other Grass seeds bush. of.	HEAR.			SILK CO.			Cane su- gar lbs. of	Molasses, gallons of	Beeswax and honey lbs. of	Value of manure vs.	Value of animals slaughtered	
				Dew Rotted tons of.	Water Rotted tons of.	Flax. lbs.	Flax Seed, bush. of.	coons, lbs. of.	Maple Sugar, lbs. of						Maple Sugar, lbs. of
MAINE.	755,839	9,097	9,214	40,120	17,081	380	252	915.1	3,167	189,618	513,596	1,646,773			
NEW HAMPSHIRE.	598,834	829	8,071	257,174	7,632	186	4,191	1,294,863	9,917	117,140	393,455	1,529,873			
VERMONT.	868,989	760	14,996	258,513	20,752	939	2,989	5,980,955	5,997	240,432	278,381	1,871,468			
MASSACHUSETTS.	651,807	1,002	121,395	1,102	1,102	929	72	795,525	4,693	56,506	2,504,924	2,504,924			
RHODE ISLAND.	74,818	1,328	3,708	221	17,925	702	328	50,756	665	93,304	26,495	667,486			
CONNECTICUT.	316,131	13,811	16,608	96,473	940,572	57,965	1,774	10,357,484	655	1,756,196	1,992,522	9,209,566			
NEW YORK.	3,725,970	88,222	96,473	1	182,905	23	2,197	2,197	954	156,694	112,781	2,628,552			
NEW JERSEY.	433,930	28,282	63,631	22,433	182,905	16,255	23	2,328,525	50,652	838,500	749,132	8,219,848			
PENNSYLVANIA.	1,812,970	125,250	33,003	22,438	529,079	41,650	285	2,328,525	50	41,218	38,121	373,605			
DELAWARE.	30,159	15,217	2,861	1,870	11,050	555	39	47,740	1,430	74,802	111,821	1,954,800			
MARYLAND.	15,226	3	2,861	15	35,686	2,446	39	47,740	550	74,802	2,075	9,038			
DIST. COLUMBIA.	369,008	29,727	23,428	11,506	599,450	52,318	517	1,227,655	40,322	890,767	2,156,312	7,605,006			
VERGINIA.	145,692	576	1,275	9,246	583,796	38,186	229	27,932	704	513,239	2,066,522	5,767,857			
NORTH CAROLINA.	20,925	376	30	26	333	55	123	2,000	15,504	216,150	738,574	1,307,657			
GEORGIA.	23,449	132	428	261	5,387	622	6	50	1,644	738,574	1,338,968	6,337,692			
FLORIDA.	2,510	2	2	14	50	50	6	643	2,752	352,933	18,971	4,237,482			
ALABAMA.	32,685	138	547	276	3,811	67	167	8,232	83,428	1,913,352	7,913,522	4,237,482			
MISSISSIPPI.	12,505	84	533	473	7	26	2	25	388	81,461	1,161,020	3,336,582			
LOUISIANA.	28,752	97	125	125	6,65	26	2	296,801	10,931,616	390,522	225,719	1,458,990			
TEXAS.	8,279	10	436	157	1,048	26	22	9,320	411,058	1,993,328	628,217	1,106,032			
ARKANSAS.	3,977	90	7	7	321	321	321	248	7,223	1,036,572	3,137,710	6,401,765			
MISSISSIPPI.	74,092	5,096	9,118	1,032	3,913	18,930	1,323	158,557	40,047	1,156,959	3,137,710	6,401,765			
KENTUCKY.	113,655	3,230	21,451	5,096	14,756	7,859	1,323	437,345	40,047	1,156,959	3,137,710	6,401,765			
OHIO.	413,142	102,197	37,310	63,531	140	30	1,323	4,588,209	308,308	804,275	1,712,196	7,439,243			
MICHIGAN.	403,934	16,989	19,785	10,552	166	37	8	2,438,987	180,325	3,932,292	3,109,947	1,328,327			
INDIANA.	463,230	401,952	18,327	11,981	584,326	36,888	387	2,921,642	8,334	869,444	1,651,039	6,576,256			
ILLINOIS.	601,952	3,427	14,327	3,130	141	160,063	47	2,483,904	8,334	4,972,956	3,349,517	4,972,956			
MISSOURI.	180,743	342	2,095	8,242	533	13,641	186	78,750	3,162	321,711	2,912,912	921,164			
IOWA.	275,682	483	433	15,930	300	68,293	246	610,976	9,874	131,005	43,621	920,178			
WISCONSIN.	2,038	433	433	15,930	300	68,293	246	610,976	9,874	131,005	43,621	920,178			
MICHIGAN.	2,019	4	22	8	640	530	5	2,930	24	1,230	1,392	1,230			
MINNESOTA.	373	2	22	50	530	5	5	2,930	58	10	1,392	1,230			
OREGON.	2,019	4	22	8	640	530	5	2,930	24	1,230	1,392	1,230			
UTAH.	4,805	2	22	50	530	5	5	2,930	58	10	1,392	1,230			
NEW MEXICO.	12,830,141	407,983	413,151	3,497,514	63,588	25,390	13,391	1,135	562,810	14,763	33,980,437	247,778	12,821,574		
													14,850,627	27,473,931	119,415,029



A COTSWOLD RAM.

THE PROPERTY OF MR. GEORGE HEWER, OF LEY GORE, NEAR NORTHEACH, GLOUCESTERSHIRE, ENGLAND, FOR WHICH THE FIRST PRIZE OF \$125 WAS AWARDED AT THE MEETING OF THE ROYAL AGRICULTURAL SOCIETY, HELD AT WINDSOR, JULY, 1851.

COTSWOLD SHEEP.

THE meaning of the name Cotswold, is a sheep-fold, and a naked hill or plain. The Cotswold hills, the native tract of this ancient breed of sheep, are of moderate elevation, covered with sweet and nutritious herbage; and though formerly a bleak, wild, and uncultivated district, given wholly to sheep walks, it is now enclosed, cultivated, and greatly improved. The sheep also have undergone a like improvement; so that they now rival the New Leicester in symmetry and early maturity, while they possess a heavier fleece and carcass. They have been crossed with the Leicester with decided advantage; their size and fleece being slightly reduced, but their tendency to fatten and early maturity, as well as the quality of the mutton, are much improved. They have also been crossed with the Hampshire Downs, thereby improving still more the quality of the mutton, but greatly reducing the weight of wool and carcass. The New Oxfordshire breed is supposed to be nothing more than the Cotswold improved by crossing with Leicesters and Hampshire Downs.

The Cotswold sheep have been imported into this country to some extent, and are held in high estimation by those who possess them. Their wool is said to be finer, longer, and heavier, than the improved Leicester; we, however, think that it is by no means a settled point. Their mutton is said to be superior, the fat and lean being more intimately mixed than the Leicesters. The South Down, however, is beyond all comparison the favorite mutton, and is driving all others out of Smithfield market, bringing from two to three cents more per pound than the large sheep.

In the June number, page 177, we stated that in some experiments then being made by Mr. LAWES, on the fattening qualities of several breeds of sheep, it was found that the Hampshire Downs fattened more easily than the Sussex Downs; and that the Cotswold yielded more fat, &c., for a given amount of food, than the Hampshire Downs, or New Oxfordshire sheep. These experiments are not yet finished or published, but a recent letter from Mr. LAWES informs us that the Cotswold increase more for a given amount of food than either the Lincoln, Leicester, New Oxfordshire, or the Hampshire and Sussex Downs. Yet, as we have before said, it is doubtful whether it is good economy to keep these large, coarse sheep, instead of the delicate Sussex Downs; the difference in the price of the mutton being so considerable in the principal English markets. These large sheep, however, yield a greater amount of tallow in proportion to lean meat, than the small breed; and as tallow commands a higher price here than mutton, (the reverse being true in England,) will not butchers pay more, or can they not afford to pay more per pound, for the large breed than for the South Downs and Merinos? The butchers in Rochester we know prefer Leicester to South Down sheep on this very account, the taste of their customers not being so fastidious as the Cockney's, and the inside tallow they obtain makes a profit in favor of large sheep.

The cut on the opposite page is a good representation of probably the best Cotswold ram in Great Britain, for it was awarded the first prize of \$125 at the great Cattle Fair of the Royal Agricultural Society of England, held at Windsor in 1851. If further experiments shall confirm the present indications that this breed will lay on more fat for a given amount of food than any other, more attention will be paid to it here in future than it has yet received. For these reasons we have been at considerable expense to give the accompanying engraving. The Cotswold being a very long-wooled, heavy sheep, they will not probably stand the severe winter of the northern and western States as well as the South Down, Merino, or other smaller, close-wooled sheep. The Teeswater, Lincoln, New Oxfordshire, and Leicester sheep, are also open to the same objection; though farmers who keep the Leicesters and other long-wooled sheep in this district and Canada, say that they stand the winter well.

Horticultural Department.

CONDUCTED BY P. BARRY.

THE attention given at the present time to the culture of dwarf fruit trees, both in the garden and orchard, in all parts of the country, renders the subject one of the most important in the whole range of horticulture; and at the hazard of repeating what we may have heretofore said, we will take this occasion to offer a few hints on their management. We are well convinced from hundreds of letters received from those who are engaged or engaging in their culture, that with all the information that has been in various ways elicited within a year or two past, there yet exists a very general want of that particular kind of knowledge—and not only knowledge, but of that earnestness and appreciation—so indispensable to success. A vast number of persons who never before gave a thought to fruit culture, are all at once tempted into it by the irresistible attractiveness of some dwarf trees, not over three or four years old, which they have seen loaded with magnificent fruit in a neighbor's garden. They look upon this as an example of fruit culture "made easy," and as a proof—as proof it is—that half a life time need not be spent in waiting for their trees to bear. A resolution is at once formed to plant a garden, perhaps an orchard. The ground is plowed after a fashion, the nearest oracle is consulted in regard to the *best sorts*, the trees are procured and planted; and there the work ends. The next year, or year after, the trees are expected to be loaded with such beautiful fruit as those which first awoke their enthusiasm and enticed them to become planters; but alas! where are they? Not one to be seen, perhaps; and not only that, but the trees generally are wanting in that vigorous, luxuriant appearance, that indicates a perfect state of health; they are, in fact, *unthrifty* and *unfruitful*, looking quite as much like dying as living. At this stage of the proceedings, it is suggested by a knowing one that these dwarf trees are a "humbug." "I told you so." Thus results, and thus will result, the hasty, ill-advised planting enterprises of a multitude of persons. We are by no means drawing upon the imagination in this matter, and we have not the least doubt but that many who read this will recognise the course of proceeding pointed out as bearing a striking resemblance to theirs.

We are very far from being disposed to aggravate the difficulties of fruit culture, or to try to persuade people that there is any mystery in the art of good cultivation, or any obstacle in the way, that common care and skill can not remove. On the contrary, we aim, and have always aimed, at giving every encouragement in our power consistent with the truth. We must confess, however, that we are frequently surprized at the comparative recklessness with which people embark in planting—spend perhaps ten, twenty, or even fifty dollars for trees, without possessing a single correct practical idea of their treatment; without having consulted any reliable work, or engaged the assistance of a competent person; relying merely upon the uncertain light of a few vague ideas picked up from some very questionable sources. What else can such people reasonably expect but a failure? And if a failure happen them, they should at once take the blame to themselves, and hasten to make amends.

Having thus alluded to what may be termed *mal practice*, we will sketch very briefly the course we would recommend. When a plantation of dwarf trees has been determined upon, whether of 10 trees or 1000, the following considerations should be carefully considered, and all the information in regard to them be obtained from the most reliable sources:

First, *The Soil*. Is it of a suitable character for the purpose? Is it too wet, or too dry? Does it require draining, subsoil plowing, or trenching and manuring? It should

always be understood that dwarf trees require a soil of the best quality; and that, too, kept in the best condition. The roots do not extend like the roots of standard trees, and must obtain a liberal supply of food from a small compass. When the soil is right in regard to dryness, depth, and richness, the next consideration should be —

The Trees. These should be on stocks most suitable for dwarfing the species; they should be healthy, vigorous, and of such growth as to be easily moulded into the form in which they are to be grown. The matter of stocks is one of the most important, and should be considered as though the entire success of the undertaking depended upon it. There is yet, even among experienced growers of trees, a very great want of knowledge on the subject. Most people act with a degree of impatience that in many cases proves fatal to their success. They must have large trees — bearing trees. Tree dealers, as a general thing, say: "Our customers want *large* trees, above all." No man who proceeds upon this principle, can make a fruit garden or orchard that will be either successful or satisfactory. What is it to wait a year, or two years even, compared to having beautiful instead of unsightly trees? We know a gentleman who is at this moment rooting up a plantation made on the principle of the "larger the better," to make room for young, well-shaped trees. Taste and experience will lead to this in time.

Next comes the question of *Varieties*. Here, instead of making out a list of the *best* without regard to circumstances, such should be chosen, and such only, as have been proved to succeed well on the stocks used for dwarfing, and are of such habits of growth as will make their training a thing practicable. In order to secure these objects, it may be necessary to dispense with favorite and first rate sorts; for it is far better to succeed *well* with a good or second rate sort, than to fail with one a degree better. Neither should a large number of varieties be made a special object; for that and entire satisfaction otherwise can rarely be obtained.

Next comes the arrangement and the planting, involving many practical details to which we can not now refer particularly.

And when all this is done, there is the *After Culture*; for trees can take care of themselves no more than domestic animals, and more especially when it is desired to maintain and enjoy a high state of artificial culture. An annual pruning, and pruning and pinching at intervals, are necessary; the nature and objects of which must be studied until well understood. Then there is manuring, which must be done in such a way as to meet the wants of the tree, keeping in view the nature of the soil; for the same quantity or kind of manure will not be applicable in all cases.

We will close by recommending to all who are cultivating dwarf fruit trees, to mulch them with half decomposed stable manure from three to six inches deep, on the commencement of winter. This excludes the frost from the roots near the surface, and the snow and rains dissolve it, and send down its best soluble parts to be taken up by the roots the following spring. This supplies the exhaustion of the previous year, and the trees are sustained in a uniform vigor. Thus mulching accomplishes a two-fold object, and may with great advantage be applied to other than dwarf fruit trees.

NUMBER OF PLANTS ON AN ACRE, AT GIVEN DISTANCES APART.—The following table may be useful to the gardener, in showing the number of plants or trees that may be raised on an acre of ground, when planted at any of the undermentioned distances. T. T.

<i>Distance apart.</i>	<i>Number of Plants.</i>	<i>Distance apart.</i>	<i>Number of Plants.</i>
1 foot.....	43,560	9 feet.....	587
1½ feet.....	19,360	12 ".....	306
2 ".....	10,590	15 ".....	193
2½ ".....	6,969	18 ".....	134
3 ".....	4,840	21 ".....	95
4 ".....	2,722	24 ".....	75
5 ".....	1,742	27 ".....	59
6 ".....	1,210	30 ".....	48

GARDEN HINTS FOR NOVEMBER.

TRANSPLANTING TREES, in many localities, may be continued through all this month ; but the earlier it can be completed, the better. No autumn planted tree can be considered in a safe condition until securely staked, if at all top heavy, and well mulched around the roots. Delicate tall standards, such as the pithy Pawlonia and Catalpa, should be mulched on the stem also—wrapped with straw or dry moss. Trees "heeled in" (laid in by the roots) should be in perfectly dry, light soil, and will be better in a slanting position than erect. Peach and other tender trees would be the better for a covering of evergreen boughs. Care should be taken to clear away all harbor for vermin near trees that are heeled in, as well as in the vicinity of all fruit tree plantations. A few days work *now* will probably save many valuable trees. Every spring we hear complaints from all quarters, about the damages sustained from vermin.

Raspberries should be laid down and covered with a few inches of earth. This is less labor than tying to stakes, and covering with straw.

Strawberry beds should be mulched either with manure, tan-bark, or decayed leaves, leaving the heart of the plant uncovered.

Mulch every tree in the fruit garden. Protect all tender and half hardy trees and shrubs, or rare trees recently planted and not yet well established. Mulch them at the roots with leaves or tan-bark, put around them a few stakes tied together at the top, and cover with straw or mats. It is bad to bind plants closely during winter.

Tender Roses can be protected by laying down and covering with leaves, tan-bark, or light earth.

Hardy Bulbous Roots, such as hyacinths, tulips, crocus, crown imperials, lilies, narcissus, &c., can be planted as long as the ground remains open ; but the beds should be immediately covered a few inches deep with leaves, litter, or tan. All tender border plants should be protected in the same way.

Dahlia Roots, Gladiolus, Tigridias, Tuberoses, and other tender roots and bulbs, should be taken up in good season, as soon as the frost has killed the stems, dried well, and put away on shelves in a dry cellar, or in boxes with sand. It is important to put them away in a *perfectly dry* state.

Operations on the ground, such as digging, manuring, trenching, levelling, &c., can be carried on in many places, even in the north, through the month of December. An inch of frost is no obstacle to such labor, and it never should be deferred till spring.

The Fruit Room will require attention. Apples for use during the latter part of winter and spring, should be put up in dry, clean barrels, and kept in a cellar as cold as possible not to freeze, and perfectly dry. Winter pears may be kept on shelves in a dry, cool cellar; or they may be put in clean boxes, between layers of clean, dry straw, or hay. The longest keepers may be put in the bottom, so as to get them out easily as their season comes. Those who may not have a cellar so dry and cool as it ought to be for pears, can put them among dry hay or straw in small boxes, and place these in other boxes in a dry, cool loft. If freezing be apprehended, a covering of mats or cloth may still be added to secure them. They should be taken into a warm room (60 or 70 deg.) a week or two before they are wanted. *The Root Cellar* will require attention. All decaying vegetables should be instantly removed.

On the 7th of October the beautiful residence of the late A. J. DOWNING, at Newburgh, was disposed of at public sale. It contained about five acres ; but from the skill of its arrangement it was made to appear of much larger extent. It contains, we think, the finest specimens of ornamental trees in this country. It sold for \$18,000, and was purchased by a gentleman residing in Newburgh.

NEW FRENCH CHERRIES.

BY B. DESPORTES, OF ANDRE LE ROY'S NURSERIES, ANGERS, FRANCE.

SOME years ago Mr. LE ROY formed, in his nurseries at Angers, a school or experimental plantation of fruit trees, which has enabled us to prove a very large number of fruits formerly known to us only by name. The spring of this year was very favorable, and we have had an abundant crop on all our fruit trees. We shall profit by this in giving to the readers of the *Genesee Farmer* a description of five varieties of cherries, new or very little known:

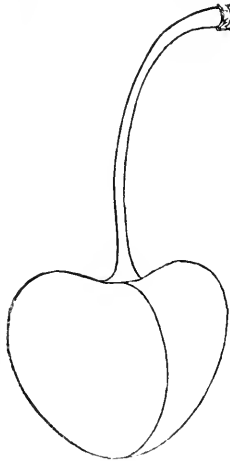

FIG. 1.

and planted in a deep cavity. *Color* blood red on the sunny side; yellow in the shade. *Flesh* white, slightly adhering to the stone,

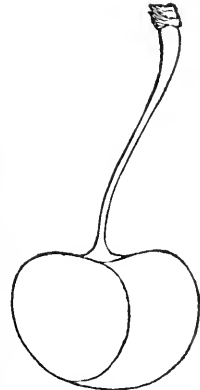

FIG. 2.

which is large, long, and channelled. Season of maturity, middle of July. It is necessary that it be well ripened before gathering, for then only does it possess all its excellent qualities. The *leaves* are large, lanceolate, deeply toothed, and have two glands on the petiole. The *tree* is large and vigorous. *Shoots* erect, long, and stout.

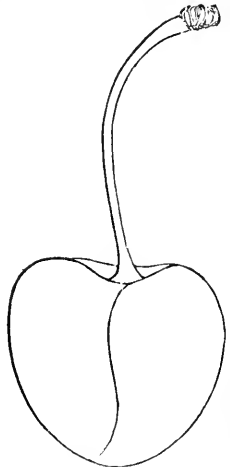

FIG. 3.

CERISE DE LA BESNARDIERE. (Fig. 2.)—*Fruit* medium size, roundish, flattened at the stalk, and divided on one of its sides by a light suture. *Stalk* one and a half to two inches long, large, and planted in a round, shallow cavity. *Color* bright red throughout. *Flesh* rosy white, parting freely from the stone; tender, succulent, slightly acid. *Stone* small, round, and smooth. Ripe beginning of July. It is moderately productive. *Leaves* small and finely toothed. The *tree* resembles the *May Duke* in its general appearance, grows vigorously, and makes a fine pyramid.

BIGARREAU MARCELIN. (Fig. 3.)—This is certainly one of the most beautiful of cherries. Very large, heart-shaped, flattened on both sides, with a suture on one. *Stalk* short, stout, curved, and planted in a shallow, irregular cavity. *Color* pale

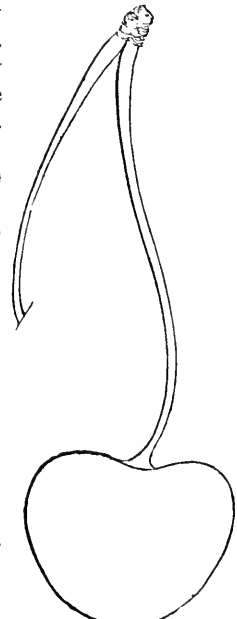

FIG. 4.

red in the shade, bright red in the sun at maturity. *Flesh* white, firm, juicy, somewhat adherent. *Stone* large, rounded on one side. Season, middle of July. I regret much not to know the originator of so good a fruit. The *tree* is vigorous. *Shoots* long, stout, and erect.

GUIGNE PRECOCE DE TARASCON. (*Tarascon Early Guigne.*) Fig. 4.—This is a magnificent large cherry, heart-shaped, very regular, slightly compressed on both sides. *Stalk* usually very long, slender, and wavy; largest at the point of union with the branch. *Flesh* tender, flesh-colored, veined with rose and white, adheres to the stone, which is large and irregular. *Color* bright red, very brilliant at maturity. *Leaves* long, quite regular. *Tree* vigorous. *Shoots* large and spreading, the buds prominent; the young shoots are veined and dotted with grey. Ripe 10th of June. This is a superb and excellent cherry, and merits a place in every garden. I do not know its origin.

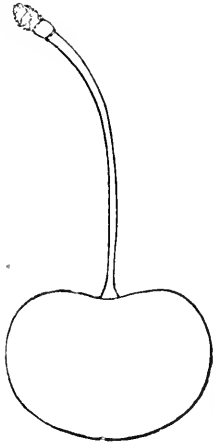

FIG. 4

DUCHESSE DE GALNAU CHERRY. (Fig. 5)—*Fruit* very large, round, compressed at both extremities. *Stalk* short, curved, and jointed at the end next the branch. *Color* bright red, sometimes deep red, even blackish red at maturity. *Flesh* tender, adhering to the stone, clouded with violet red, juicy, slightly acid, very agreeable. *Stone* round and smooth. *Leaves* short, slightly toothed, and furnished with two glands on the petiole. *Tree* of medium vigor, pyramidal in form. *Shoots* short and erect, short-jointed. In general habit similar to the *May Duke*.

Ripe end of June. This is a variety of great merit.

I shall at all times, as opportunity may offer, be happy to make known to a country so eminently horticultural as the GENESEE, the progress and discoveries which we make at Angers.

WESTERN EXHIBITIONS.

By permission of the writer, Dr. J. A. KENNICOT, of The Grove, Illinois, we extract from a private letter the following notes on the late agricultural and horticultural exhibitions in Wisconsin and Illinois. The Great West is awake in earnest. The Ohio State Fair eclipsed all other fairs of the kind ever held in this country. Michigan, Illinois, and Wisconsin, are following. Hear what the Doctor says:

"I first attended the Lake County (Illinois) Fair of their united Agricultural and Horticultural Societies, in the very pretty town of Waukegan, formerly Little Fort. A good first show of the former, and a very excellent one, as usual, of the latter. Splendid horses, very fine full blooded and grade cattle, and sheep and swine quite creditable. Farm products, in general, very fair; but implements not so abundant. Fruits and flowers, beyond all expectation, choice and abundant; apples being the great feature, but pears quite encouraging; and plums too, and even a considerable display of peaches under name; grapes, also, in variety, and very well ripened, in fine bunches; glorious dahlias, &c., &c. J. AMBROSE WIGHT, formerly the editor of our *Prairie Farmer*, gave us one of his learned and spicy addresses—full of wit, and beauty, and practical illustrations. The *Prairie Farmer* will miss Mr. WIGHT.

"Our Convention, or meeting of 'Northwestern Fruit Growers' Association,' at Dixon, was more than respectably attended—over fifty regular paying members present, and a house full of those who came to learn. Such a show of apples I never saw before—large, fair, and in great variety and abundance—the product of an hundred orchards. Plums and peaches, none to speak of, and only a slim show of pears. A good show of grapes. We had members from five western States; and we all worked, and most of us talked a little, though no long speeches, except perhaps one from your friend the 'old doctor,' who was called upon, at the public session, to say something on 'Industrial Education,' and the death of our beloved leader—DOWNING. We passed appropriate resolutions on the last theme, and unanimously endorsed the principle of education 'in a knowledge of things next to us.' But you will get our proceedings, which are to be printed in pamphlet.

"From Dixon we went directly to Milwaukee, to attend the Wisconsin State Fair; and a great Fair the Badgers have had. Their officers all courteous and full of energy and good will; the grounds, a private race course, very extensive and beautiful; and the weather fine during the two first days. Horses of all breeds, from the imported Shetland pony up to the largest and boniest cart horse. It struck me, however, (though I am not learned in these matters,) that the contributors in this line were more *liberal* than *select* in their display of show horses. There were some great goers though, and of *their* merits I could better judge. The *grades* in the cattle line were most abundant; but there were some beautiful animals of pure blood, which, as competent eastern judges assured me, I was not wrong in believing equal to most shown in eastern States. Sheep were there in plenty, and in all their pure excellence and desirable grades. Wisconsin, you know, is a wool-growing state. Swine were there, good pigs too, most of them; and the symptoms of the 'chicken fever' were unmistakable—a dozen or more large lots showing that the affection has reached Wisconsin.

"Bah! I see I have finished my sheet, and said nothing—all common place, if not out of place, as I know little about stock, *scientifically*.

"Well, the products of the farm, and especially the dairy, were abundant and good; and you may depend that the 'Badgers' have been digging in the right way, and that they are in earnest about this Society,—and they ought to be, for they have got the most *active*, as well as *intelligent* and *determined*, young Secretary that any Society can boast. He is as near like B. P. JOHNSON as a young man of little practical knowledge of agriculture, and but a year or two's experience in office, can possibly be. The Wisconsin State Agricultural Society is in luck, and if ALBERT C. INGHAM remains in his present position until he is thirty years old, (he is only twenty-three now) I predict great things for Wisconsin Agriculture.

"I can't praise the show of fruits and flowers, though both are respectable. Some good late plums; plenty of apples, not quite so large as those of Illinois, nor in so great variety; some pears and grapes, but no great variety. Dahlias, and other late flowers from Kenosha, from Capt. CANOON I think, were decidedly good. Milwaukee did not show flowers as she might have done, though Mr. MESSENGER had fifty or sixty sorts of fine Green House plants, in good condition. The show of implements was respectable."

ANNUAL FALL EXHIBITION OF THE GENESSEE VALLEY HORTICULTURAL SOCIETY.—This exhibition was held on the 22d and 23d of September. The show of fruits was the best (excepting peaches) ever seen in Rochester. The collections of apples and pears were as good as any, if not the best, we have ever seen; and when spread out on the tables, tastefully arranged, formed a museum of rare interest and beauty.

J. W. BISSELL, Esq., exhibited a fine collection of foreign grapes from his vineyard, that attracted much attention.

JAMES VICK, JR., made a good show of annuals, that were very attractive. Asters, Balsams, Ten week Stocks, Phlox Drummondii, Godetias, Leptosiphons, Argemone, &c., were all fine.

The nurserymen made a good display of pot plants and cut flowers. Dahlias, the glory of these autumnal shows usually, were in a great measure wanting, in consequence of the dry weather and swarms of grasshoppers in August and September. C. J. RYAN alone made a fair display.

MR. PHILIP PARKS, of Victor, presented a collection of wild flowers from his farm.

A few fine vegetables were shown by MR. THEODORE BACKUS, JOHN DONNELLAN, and C. F. CROSMAN.

MR. VICK exhibited fine Lima beans, Mexican and White Mercer potatoes, and Stowell's sweet corn. Superb watermelons were shown by JNO. DONNELLAN. Some of them were sold at the close of the exhibition, for the benefit of the Society, at five or six shillings each. MR. DONNELLAN had on his table some fine *Rose winter Radish*, the seeds of which we brought from France.

The attendance of visitors was thin, owing to the prevailing sickness at that time; but those who were present, expressed themselves delighted with the whole affair.

ACKNOWLEDGEMENTS.—We are indebted to JAMES ROBY, Esq., of Brockport, for a basket of *White* and *Gray Dogeone* pears. The specimens of the latter were particularly fine. Mr. R. considers them in some respects superior to the *White*, and we agree with him. The tree is not quite so vigorous in growth as the *White*, but it is hardy and an abundant bearer.

We must take this occasion to say that the lands around Brockport are admirably adapted to the pear, and are destined soon to be largely devoted to its culture.

Also, to JAS. H. WATTS, for *Sheldon* pears, which were supposed last season to be the *Oswego Brurree*. Mr. W., in his note accompanying them, says: "The product of our own State, it having originated in Huron, Wayne county, we may indeed congratulate fruit-growers as well as fruit-lovers, that we have now found another *first rate* pear for them to add to their varieties for cultivation.

Ladies' Department.

FLOWERS AND FLOWER SEEDS.

WE have received many letters from our female readers, thanking us for our gift of flower seeds, and detailing their methods of cultivation, and the result of their labors. Some beautiful boquets have graced our editorial table, the arrangement of which, as well as the perfection of the flowers, spoke well for the taste and skill of the fair cultivators. That some kinds have failed in some instances, is not strange. The art of cultivating even a dozen varieties of annuals is not learned in one season, and better learned by observation and practice than in any other way. Those who have cultivated flowers this summer with even partial success, will do better next, and will become the teachers of this beautiful art. Friends and neighbors will seek of them seeds, and instruction in their cultivation, which will be freely given; and thus a love of the beautiful in nature will spread over our happy land. Many plants, such as Ten week Stocks, Petunias, &c., that have not blossomed freely in the open ground, on account of late planting, may be taken up carefully and put in pots, when they will blossom in the house during winter.

DWARF CONVULVULUS.—The Dwarf Convolvulus is a beautiful flower, with three distinct colors, blue, yellow, and white; the blue being of every shade, from purple to a delicate azure blue. We have also the white and striped. The species is a native of Spain, Portugal, Sicily, and the north of Africa, and was introduced into England from Portugal early in the seventeenth century. Some botanists suppose this species to have been originally only found in Barbary; but whether introduced or indigenous, it is now a common weed, both in Spain and Portugal. The flowers always fold in gloomy weather and at night. The French call it *Belle-de-jour*. When the seeds are sown, a shallow drill should be made for them, in which the seeds may be dropped and covered lightly. When the plants come up, they should be thinned so as to stand about an inch apart. They require a dry situation, and rather a rich, light soil. Sow early in the spring, and they will commence flowering in July, and continue until covered with snow. We have several beds now, (Oct. 26th.) exceedingly beautiful, that have been in blossom since early in July.



DWARF CONVULVULUS.

The **CONVOLVULUS MAJOR**, or *Morning Glory*, is too well known to need a description; it being one of the most common as well as the most beautiful and easily cultivated of our climbing annuals. It requires the same treatment as the Dwarf Convolvulus, but needs strings or poles on which to climb. It makes an excellent covering for arbors, porches, &c.

Editor's Table.

TRANSACTIONS OF THE WISCONSIN STATE AGRICULTURAL SOCIETY, FOR 1851.—We are indebted to ALBERT C. INGHAM, Esq., Secretary of the Wisconsin State Agricultural Society, for a copy of its Transactions for 1851. It is a well filled volume of 336 pages, and alike creditable to the Secretary, under whose directions, we presume, it was brought into existence, to the Society and State whence it emanates. Wisconsin has great Agricultural resources; and its citizens appreciate them, and proceed at once to their rapid and successful development. This is as it should be; for we do not doubt that the wise suggestions of Dr. LATHROP, in his Annual Address before the State Society, in behalf of education in general and a University in particular, will be responded to by the people of that young and promising commonwealth. To avoid the deterioration of their soil, they must early adopt a better system of tillage and husbandry than is pursued in older States.

THE HORTICULTURIST.—It will be seen by the Prospectus in our columns, that the *Horticulturist*, heretofore edited by the lamented DOWNING, has been purchased by J. VICK, JR., one of the editors of the *Farmer*, and is to be published in Rochester, edited by P. BARRY. Those who have read the Horticultural Department of the *Genesee Farmer* will need no guarantee that Mr. BARRY is eminently fitted for the post he has assumed, at the almost unanimous request of the Horticulturists of the country. Those of our readers who are turning their attention to the cultivation of Fruits and Flowers, or to beautifying their homes, would make a profitable investment in subscribing for the *Horticulturist*. The subscription price is reduced to \$2 per year; an edition with Colored Plates is also to be published, at \$4.

PEAS, AND PORK MAKING.—A friend, from St. Johnsbury, Vt., writes us that the article on Peas and Pork Making, in the September number, differed somewhat from his experience; that he had boiled peas once or twice for his hogs, but they would not eat them. Corn and peas are worth \$1.00 per bush., and pork \$8.00 per hundred nett, and thinks that at these relative prices it does not pay to feed hogs, except for home consumption.—He thinks that farmers in New England should commence feeding their cattle with hay, corn and roots in February, and have them fit for sale in April or May, when beef is highest. Can fat full grown animals on good hay alone, but growing

animals require a little grain, or they will not fatten. In either case, he thinks it good economy to feed a little grain.

Our friend mistook our meaning in supposing us to recommend "boiling peas" for hogs. What we said was, that it was advisable to "soak them from 12 to 24 hours in cold water before feeding them to hogs." They are in consequence of soaking, more easy of mastication, and fewer pass through the animal undigested than when fed dry and hard. We know that hogs do not like "boiled peas," but they manifest no disrelish for them when soaked.

TRIAL OF IMPLEMENTS AT GENEVA, N. Y., JULY, 1852.—The following is a list of the Premiums awarded by the N. Y. State Agricultural Society to the successful competitors, at the trial of Implements, at Geneva, in July last. We should have given it last month, but preferred waiting for the official report. Here it is from the Journal of the Society.

Grain Reapers.—1st, T. D. Burrall, Geneva, Burrall's Reaper, Dip. and \$50. 2d, J. H. Manny, Wadhams Grove, Illinois, Manny's Convertible Reaper, for grain or grass, 30, Seymour & Morgan, Brockport, 20.

Mowing Machines.—1st, J. H. Manny, Wadhams Grove, Illinois, Dip. and \$50. 2d, Howard & Co., Buffalo, Ketchum's Mowing Machine, 30.

Grain Drills.—1st, P. Seymour, East Bloomfield, N. Y., Dip. and 25. 2d, Bickford & Juffman, Macedon, N. Y., 15. 3d, S. R. Tracy, Newark, N. Y., 10.

Horse Power on the Leever Principle.—1st, J. A. Pitts, Buffalo, Dip. and 25. 2d, Eddy, Dyer & Co., Union Village, Wash. Co., N. Y., 15.

Horse Power, endless chain principle.—1st, Emery & Co., Albany, Dip. and 25. 2d, E. W. Badger, Fly Creek, N. Y., 15.

Iron Horse Power.—1st, B. H. Wakely, McLean, Tompkins Co., Dip. and 25. 2d, Eddy, Dyer & Co., Union Village, N. Y., 15. 3d, J. A. Pitts, Buffalo, 10.

Threshing Machines, with cleaning apparatus.—1st, J. A. Pitts, Buffalo, Dip. and 10. 2d, Hall & Thompson, Rochester, 8.

Threshing Machines, without cleaning apparatus.—Eddy, Dyer & Co., Union Village, N. Y., Dip. and 10.

Seed Planters.—Joshua Woodward, Haverhill, N. H., Dip. and 10.

Cultivator, general purposes.—1st, S. R. Tracy, Newark, Wayne Co., Dip. and 10. 2d, Henry Howe, Canandaigua, 5.

Broadcast Sower.—Pierpont Seymour, East Bloomfield, Dip. and 10.

AUSTRALIAN WHEAT.—Several of our friends have requested some of our Australian Wheat, &c.—We had none in our possession at the time and were unable to procure any till the period of sowing was gone by. Another year, however, we shall procure a quantity in season, and shall be happy to send some to any who desire it. Some farmers who have tried it in this section, think it does not ripen early enough here, requiring a warmer climate than Western N. Y. The Multicaul Rye has been sent to all who asked for it.

Inquiries and Answers.

(T. CHASE, Otego, N. Y.) The paper was labelled right. The sprig you sent is Sweet Mignonette.

(M. BRITTEN, Spring Prairie, Wis.) The standard weight of Flax seed in New York, is 56 lbs.; of Timothy seed, 45 lbs. per bu.

BEES.—Having concluded to give a part of my attention to the raising of bees, I am obliged to make a few inquiries with regard to it. Bees are generally much affected in this part of the country with the miller, which has caused many to abandon the keeping of them. Do you know of any means by which the miller can be destroyed or prevented? Some say that bees should be kept in a house; but I neither know how the house should be constructed, nor how bees should be got into it. By giving what information you can with regard to this, in the "*Farmer*," you will greatly oblige a Canadian subscriber. JAMES HAWKSWORTH.—*Venezia, C. W.*

We give the above letter, and respectfully invite some one familiar with the subject to state what he regards as the best protection against the bee-moth; and the best plan for a bee-house. In the mean time, Mr. MINER'S Bee Manual is recommended to our correspondent, as a work worthy of his perusal.

SWAMP MUCK.—In the month of August last, I deposited one hundred loads of swamp muck in my barn-yard. I propose to apply it to my corn land in the spring, a part of which is an apple orchard. Will it prove beneficial to next season's crop of corn, and also to the fruit trees? In your next number, please suggest the best method of preparing and applying this kind of manure. E. W. BOTTOM.—*Auron, N. Y.*

We have several times seen swamp muck applied to fair soils in Western New York, and never with any decided benefit. As an absorbent of stable or barn-yard manure, dry muck is valuable; because the ammonia developed in the manure neutralizes the organic acid in the muck that prevents its rotting, and the whole mass (muck and manure) decomposes together, and yields food for plants, apple trees included. All manure in barn-yards is liable to damage and waste from an excess of water; and the hauling of swamp muck into an open yard will not obviate the difficulty. A little water from rain or snow does no injury; but a good deal either carries off a part of the manure, or compels the farmer to haul some nine loads of water to his fields to convey thither one load of solids, whether straw, hay, muck, or dung. This involves a prodigious waste of labor, and can only be avoided by keeping yards in which manure is made, partly, or entirely sheltered from rain, and protected from the droppings of eyes, or receiving running streams from without, as we have frequently witnessed.

The art of producing good manure is not so generally, nor so thoroughly understood, as it ought to be. The process of decay or rotting de-

pends partly on the temperature, partly on the chemical nature of the matters operated upon, and partly on the fineness and degree of moisture of the materials. At another time, when our pages are less crowded than at present, we will discuss this interesting and important branch of farm economy, at length.

WINTER BARLEY.—Mr. E. E. FAY, of Marengo, McHenry county, Illinois, wishes to obtain a small parcel of winter barley.

Both barley and oats endure with impunity the winters of the south in the cotton-growing States; but we have never seen either that would be likely to survive, if sown like wheat in autumn, the frosts of central Illinois.

Having written to Mr. SPADER in relation to the Winter Barley noticed by him in the May number of the *Farmer*, Mr. S. has kindly sent us the following:

"Yours of the 18th inst. was duly received. In answer, I would say that in consequence of the prevalence of the cholera in many places on the route to your State Fair, I gave up attending as I had expected. Respecting my crop of Barley, I will say that the yield was not so good as the year previous—on an average, I suppose, about 40 bu. per acre—which I think was owing to a part not having been sown till near the middle of October, and the unfavorable weather in the spring. The fore part of March was very pleasant and the young grain grew rapidly, but on the 19th we had a very severe freeze which lasted several days and killed considerable of the Barley, and also the wheat of late sowing. My first sowing, I judge from the shocks per acre, would turn off 60 bushels. A neighbor of mine, who I furnished with seed, had an excellent crop, full 60 bu. per acre. I have not threshed much of my crop, only about 200 or 300 bu. which I sold for seed at 75 cts. per bushel, and suppose I have 1200 bu. for sale. The time is past for sowing. My crop is all up and looks very well. The fall has been favorable for seeding. I can furnish any amount of seed from the next year's crop, in time for the next year's sowing, at such price as may be hereafter agreed on. I began cutting my crop this year on the 18th June, but that was later than usual. From the 1st to the 20th September, in this country, is a good time for sowing. BENJ. SPADER.—*Logansport, Ind.*

Mr. F. asks "whether summer fallowing prairie land will pay expenses, where the soil is mainly sand and vegetable mold?" He adds: "I wish to know if plowing light soils two or three times is of any use?"

As a general rule, this practice is not to be commended; sometimes, however, where the ground is foul with weeds or grass, repeated plowings are necessary to clean the land, and bring it into fine tilth.

Mr. F. says that chintz bugs cover their fields, and have done considerable damage to the grain crops of that section. A remedy is desired.

CRANBERRIES.—Some four years ago I saw an article on the Culture and Profits of the Cranberry. This induced me to give it a trial. In doing so, I found to my satisfaction that it neither wanted great expense or skill to arrive at the point. In the article alluded to, it was stated

that any land that would produce a good crop of corn would produce cranberries. My experience proves that a dry soil will produce plants, and but little or no fruit; while the wet or boggy soil will produce abundance of both. But my object is not to instruct, but to answer an inquiry in your paper last spring, where plants could be had? Now I would say, should there be a call, I would furnish them in any quantity, in boxes holding five bushels and upwards, at \$2.50 per bushel, to be delivered at the Railroad Depot or Steamboat Wharf. J. FARMER.—*Cape Vincent, Jeff. Co., N. Y.*

BARN AND COW-STABLE.—I have been some years a subscriber to your very valuable periodical, and have noticed with pleasure and profit the many designs for cottages and dwellings that have appeared in your paper, and have looked in vain for plans of small barns and out-buildings. Can nothing be said or done to improve these necessary buildings, both in appearance and convenience? My acquaintance is not extensive; but I would say, that although I know of some good models for grain barns, I know of none that are well adapted for storing feed, wintering cattle, and saving manure.

As I am wishing to erect a barn, or building capable of containing twenty cows and their food during winter, and to milk them in or under in summer, will you or some of your able correspondents present a plan having reference to the following considerations:

1. The building should be just large enough; not too large.
2. There should be convenient and easy storage for hay, so as not to pitch it all aloft.
3. Should there be a cellar? If so, how large, &c., to correspond with the room for hay, and number of cattle.
4. Convenience of feeding, and ease of access by each cow.
5. A convenient way and place for saving all the manure, both liquid and solid.

I would also ask what is the best method of confining cattle, whether by stanchions, or by chain or rope? How many feet are required for each cow? What kind of rack or mangers? How many hours in twenty-four may they be confined on a floor?

If you or any one chooses to notice or answer this, together with any suggestions or information relating to stock or buildings, they will favor and benefit me, and possibly some one else. LEVI PADDOCK.—*Woron, N. Y.*

SHEEP DISEASE.—I have been a reader of your valuable paper for three years, and have seen no notice of a disease that is now making fearful ravages among my sheep. The disease is first manifested in their dull and stupid appearance. They soon become lame, often losing the control of a leg, and frequently straining to make water, and although they do not appear in great pain they die in ten or twelve hours, in one instance only having lingered along as many days. I have opened and examined them without finding anything that indicates disease, save a slight infection of the liver—no appearance of the common diseases of the country. I first thought they might have eaten poisoned food, but the disease being confined exclusively to the ewes, seems not to favor this idea. I have been thus particular, hoping you or some of your numerous readers know something of the cause and remedy for this fatal disease. D. N. SABIN.—*Shawnessee, Mich.*

HORTICULTURAL.

(G. L., Meadville, Pa.) To SAVE PEACH BUDS.—“Earthing up” will effect your object, but the application of grafting wax is not advisable.

(J. D. H., South Butler, N. Y.) You can take your budded peach trees up with safety, and lay them in dry ground for the winter. It will not hurt the buds to be covered with earth.

(C. M., Port Clinton, Ohio.) The large plum

you describe as seven and a half inches in circumference one way, and six the other, weighing three ounces, is the *Yellow Magnum bonum*, or *Yellow Egg*.

Basket Willow, or Ozier, can be had in small quantities at least, in most of the nurseries. It could not be grown successfully or profitably on land overflowed six months in the year. You will find some information in back numbers of the *Farmer*.

(D. S., Stockbridge, Mass.) The best time to transplant very large trees is in winter, when the ground is frozen and they can be moved on sleds. A deep trench should be dug around each, at such distance from the tree as will leave an abundance of roots, and when the ball of earth remaining around the roots is frozen solid, the tree can be moved to its new situation. We have seen very large trees thus moved successfully, with a pair of horses and a sled, and three or four handy men. Deciduous trees should have the heads well reduced by a shortening, and in some cases a total lopping off of branches. Some evergreens will also bear this, such as Hemlock, Red Cedar, Arbor Vitæ, &c., &c.

(JAMES A. NELSON, Mercers Co., Pa.) It is not uncommon in some localities for both apple and pear trees to be injured on the trunk, near the ground, by the freezing and thawing in winter, but we cannot understand the injuries or disease you describe as attacking the trunk higher up.

PEAR BLIGHT.—MR. ASA PALMER, near Geneva, N. Y., says that cutting off a portion of the roots of pear trees will preserve or cure them of the blight. We cannot agree with Mr. PALMER.

(M. K., Bentonville, Ind.) **PEACH TREES.**—Planters differ in opinion in regard to the advantages of fall and spring planting. In mild climates, and *dry, light* soil, we would advise fall; in severe climates, or damp soils, the spring. To keep worms from killing them, examine the trees once or twice a year, and pick out with a knife any that are to be found. A peck of leached ashes laid around every tree, in the spring, will aid in keeping them off.

(Several Correspondents.) We have not yet received the proceedings of the Pomological Convention at Philadelphia, but hope to very soon. Copies may possibly be had by applying to some of the Secretaries—JAMES H. WATTS, Rochester, F. R. ELLIOT, Cleveland, or H. W. S. CLEVELAND, Burlington, N. J.

(R. S. HOWE, Lebanon, N. H.) Your box of fruits is received in good order, and we are greatly obliged. We will report upon them in the next number of the *Farmer*.

THE GENESEE FARMER FOR 1853.

ONE more number completes the present volume. To those who have read the *Farmer* the present year, we need not say that we have spared neither labor nor expense to make our paper interesting and valuable. But for our large and almost unparalleled circulation, every volume we print would cost us more than the price charged to subscribers. To our friends and agents everywhere, we tender our acknowledgements for past favors, and hope to increase our indebtedness another year. Let every subscriber spend an hour in calling the attention of his friends and neighbors to the claims of the *Genesee Farmer*, and we shall more than double our circulation the coming year. Let all engage in this work, and form clubs early.

The Practical and Scientific Farmer's own Paper.

THE GENESEE FARMER,
A MONTHLY JOURNAL OF
AGRICULTURE AND HORTICULTURE,
ILLUSTRATED WITH NUMEROUS ENGRAVINGS OF
Farm Buildings, Domestic Animals, Implements, &c.

VOLUME XIV, FOR 1853.

DANIEL LEE, JAMES VICK, Jr., & JOSEPH
HARRIS, EDITORS.

P. BARRY, Conductor of Horticultural Department.

IN issuing a Prospectus for the FOURTEENTH Volume of the *Genesee Farmer*, the Publisher flatters himself that it is too widely known, too extensively circulated, and too well read, to render it necessary to state the design of the work. Those who read the *Farmer* are the best judges of its value, and those unacquainted with it are invited to examine its pages.

The Fourteenth Volume will commence on the 1st of January, and will be issued regularly on the 1st of each month during the year. It will be printed on new type and superior paper, each number containing THIRTY-TWO PAGES, and making at the end of the year a Volume of 384 pages, with title page, index, &c., suitable for binding. The work is appropriately illustrated with beautiful and really valuable engravings of Farm Buildings, Implements, Domestic Animals, Choice Fruits, Flowers, Shrubs, &c.—The Volume for 1852, when bound, will make the most valuable Volume on Agriculture yet published in this country. The Volume for 1853 we design still farther to improve, and hope to be sustained in our efforts by the farmers of the country.

We number among our Contributors, hundreds of the best Practical Farmers in the country, and our readers have through our pages, the benefit of their wisdom and experience. No thinking man can read any number we issue, without receiving some useful hint in regard to the management of crops, stock, or the orchard, of more value than the price of the volume. The *Genesee Farmer* is by far the Cheapest Agricultural Journal published in America.—Our FORTY THOUSAND SUBSCRIBERS place us

ahead of all other Agricultural Journals, and enable us to furnish a paper for the trifling sum of *Three or Four Shillings*, equal to any, both in value and beauty. Its position as the *Cheapest*, and at least one of the *Best Agricultural Journals* in the country, is fully established, and we confidently ask for it that support which it merits from the Farmers, Gardeners, and Fruit Cultivators of the United States. We invite all who feel the importance of sustaining this work, and extending its usefulness, not only to subscribe themselves, but to introduce it to the patronage of their friends.

Fifty Cents a Year, In Advance.

Five Copies for \$2—Eight Copies for \$3, and any larger number at the same rate.

☞ All subscriptions to commence with the year, and the entire volume supplied to all subscribers.

☞ POST-MASTERS, FARMERS, and all friends of improvement, are respectfully solicited to obtain and forward subscriptions.

Subscription money, if properly enclosed, may be sent (post-paid or free) at the risk of the Publisher. Address to

DANIEL LEE,
Rochester, N. Y.

November, 1852.

POSTAGE LAW.—By the new Postage Law, which took effect on the 1st of September last, the postage on the *Genesee Farmer* for one year is as follows,—when paid quarterly in advance:

Anywhere in the State of New York, . . . 3 cts.

Anywhere in the United States, 6 cts.

Northern N. Y. Live Stock Insurance Company, Plattsburgh, N. Y. For terms, please apply to agents of the Company.

Seeds.

FOUL MEADOW GRASS SEED, Genuine; Fine Lawn Grass; English and Italian Ray Grass; White Clover, &c., for sale by RALPH & CO., Union Ag. Warehouse and Seed Store, 23 Fulton St., New York. [11-21]

French Zinc Paint.

THIS new and beautiful article of Paint is now offered to the trade and public, ground in prepared linseed oil, for the first time in this country. It has been used successfully in France for the last five years, where it has superseded white Lead as a paint.

The French Zinc when properly prepared and used, makes the most brilliant and durable white in use, and is entirely free from all poisonous qualities.

The French Zinc is not more expensive than white lead, and is prepared in such a manner that it requires no farther preparation for use, than to thin it with Turpentine or raw Oil to the consistency of white lead paint.

The French Zinc is very much whiter, and has a better body, than the New Jersey Zinc.

The French Zinc is offered dry, and prepared as above, in quantities to suit purchasers, at the Manufacturer's Depot, No. 17 Buffalo st., Rochester, N. Y.

July, 1852, M. F. REYNOLDS.

Monroe Nursery.

TO those who have purchased trees of me, at the Monroe Nursery, it is unnecessary to say anything here; but the public generally I would recommend to call and examine my stock of trees, for they are, without doubt, the most thrifty and stocky that can be found in any nursery around. It is true, I can not boast of 100,000 of one kind, 100,000 of another, 50,000 of another, &c.; but this I can say, that I have 40,000 fine, thrifty, well grown apple trees, three and four years old, all of the best leading varieties, ready for delivery this fall. Also, cherries, pears, peaches, &c., in like proportion, all of which are offered low, and very low to wholesale jobbers.

My facilities for obtaining buds and scions from bearing trees, are likewise unsurpassed by any other nursery, having, since I have owned and carried on the nursery, (now going on ten years,) set out new standards of all the best leading varieties, all of which are in bearing condition.

CHARLES POWIS.

Greece, Ridge Plank Road, Oct., 1850.

SINGLE HORSE POWER AND CHURNING MACHINE.

This machine has been extensively used in large dairies and with the most satisfactory results. The power is found to be peculiarly adapted to churning, the propelling force being produced by the weight of the horse to an amount sufficient to drive 4 or 5 barrel churns. The motion is varied by altering the elevation of the power so as to produce all the changes in speed required in the different stages of the process of churning. This is done by means of a lever and without stopping the horse, so that the motion is always under the control of the person in charge. The power is the same as that made by us for threshing, &c.

WHEELER'S FEED CUTTER.

This machine is made expressly for Horse Power use, and is very strong and substantial. It cuts not only corn stalks, but hay and straw with equal facility, and does its work with great rapidity. Price, \$25.

LAWRENCE'S SAW-MILL.

This mill is much used on railways, for sawing wood for locomotives, as well as by farmers, for cutting stove fuel. With a one horse power it will cut from 10 to 15 cords of wood twice in two per day. Price, (with 24 inch saw,) \$35.

WHEELER'S CLOVER HULLER.

This machine is compact, simple and durable. It does its work perfectly without injuring the seed, and is capable of hulling from 5 to 15 bushels of clover seed per day, with one horse. Price, \$28.

TROJAN PLOW.

The subscribers are also the sole agents in Albany for the sale of the celebrated "*Trojan Plow*," made by N. B. Starbuck, of Troy. These plows are doubtless superior to any other kind in use, and will be sold by us at the manufacturer's prices.

☞ All machines made and sold by us are warranted to give satisfaction, or they may be returned after a reasonable time for trial. Orders are solicited and will be promptly filled.

WHEELER, MELICK, & CO.,

Corners of Hamilton, Liberty, and Pruyn streets,
(Near the Steamboat Landing,) Albany, N. Y.
August, 1852.

The subscribers have obtained from Messrs. Wheeler, Melick, & Co., of Albany, the exclusive sale in Rochester, and general agency in Western New York, of their celebrated Agricultural Machines, which we will sell at their Albany prices, adding transportation.

J. RAPALIE & CO.

Field Seeds.

AUSTRALIAN WHEAT—Very superior. The berry of this grain is extra large, and makes the best of flour. It produces a greater average crop than any other variety now grown in New York. Several years' experience in its cultivation, proves that it is less liable to rust or mildew than other kinds; and as the stalk is large and strong, it is also less liable to blow down or lodge. Price, \$4 per bushel. Other varieties of wheat, such as the White Flint, Mediterranean, Black Sea, &c.

BUCKWHEAT, of the best kinds in market.

RUTA BAGA, or Swedish Turnep Seed. The Purple Top and other superior varieties.

TURNIP SEED—Large White Flat, Long White, Red Top Flat, Yellow Aberdeen, Yellow Stone, and other improved kinds for the field or garden. A. B. ALLEN & CO.,
June, 1852.—6-4f. 189 & 191 Water st., New York.

Improved Subsoil Plows.

THE subscribers offer for sale an Improved Subsoil Plow, made under the advisement of Prof. J. J. Mues, and free from the objections urged against those formerly in use. The wearing parts are so arranged that they may be easily and cheaply renewed, while the amount of force requisite to move them is less than half that required by those previously made.

Price—One Horse Plow, \$5; with draft rod, \$6. No. 1, with draft rods, \$3.50. No. 2, do., \$11.

LONGETT & GRIFFING,

June, 1852.—6-3L No. 25 Cliff street, New York.

Northern N. Y. Live Stock Insurance Company, Plattsburgh, N. Y. For terms, please apply to agents of the Company.

GREAT SALE OF BLOOD CATTLE.

ON Wednesday, the 18th of August next, I will sell the chief part of my large herd of Blood Cattle—chiefly cows, heifers, and heifer and bull calves—comprising upwards of fifty full-bred Short-Horns.

Also, eight thorough-bred Herefords—a two years old bull, a yearling bull, three cows, and three calves. One of the Hereford cows ("Rarity") was imported from England by Messrs. Corning & Southam, in 1841. The others, excepting the two years old bull, are her descendents, by bulls of the same stock.

Also, two or three Devon bull calves, got by Mr. Ambrose Stevens' imported bull "Candy," bred by the distinguished Mr. Quarry, of Devonshire, England, and out of cows descended from the herd of the late Earl of Leicester.

The remainder of the cows and calves, forty to fifty in number, are high-bred Short-Horn grades, with a dash of Devon blood in some of them.

The calves of the thorough-bred Short-Horns and grade cows, are mostly got by the imported Short-Horn bull "Duke of Exeter," (10,152,) of the celebrated "Princess farm," bred by Mr. John Stephenson, of Durham, England, whose herd is excelled by none, if equalled, by any now in England.

All the Short-Horn and grade cows and heifers which come in season, will be bulled, previous to the sale, by "Duke of Exeter."

Many of the cows, both thorough-bred and grade, are descended from the Bates bulls "Duke of Wellington," imported by George Vail, Esq., of Troy, N. Y.; and by "Symmetry," son of "Wellington," out of Mr. Vail's imported Bates cow "Duchess."

This stock has been bred with a strict regard to their milking quality, in which they have been fully proved, and are not excelled by any herd of cows in the United States. They are all gentle, with fine silky udders, milk easy, and are animals that will be satisfactory to any one in want of the best breeding and milking stock.

The sale will take place at the residence of Peter Gurbane, two miles above Albany, on the Troy road, on the homestead farm of Gen. Van Rensselaer, where the cattle will be for a week before the sale.

Catalogues with pedigrees will be prepared by the 15th of June, and sent by mail to all post-paid applicants.

I will also sell at the same time, two pairs of six years old thorough-bred Short-Horn oxen, and two or three pairs of matched steers.

Also, ten or twelve South-Down buck lambs, got by an imported ram, from the unrivalled flock of Jonas Webb, of Babraham, England, and from Ewes descended from the flocks of Mr. Webb, and Mr. Ellman of Sussex.

LEWIS F. ALLEN.

Black Roek, N. Y., May, 1852.—6-3f*

French Zinc Paint.

THIS new and beautiful article of Paint is now offered to the trade and public, ground in prepared linseed oil, for the first time in this country. It has been used successfully in France for the last five years, where it has superseded white Lead as a paint.

The French Zinc when properly prepared and used, makes the most brilliant and durable white in use, and is entirely free from all poisonous qualities.

The French Zinc is not more expensive than white lead, and is prepared in such a manner that it requires no further preparation for use, than to thin it with Turpentine or raw Oil to the consistency of white lead paint.

The French Zinc is very much whiter, and has a better body, than the New Jersey Zinc.

The French Zinc is offered dry, and prepared as above, in quantities to suit purchasers, at the Manufacturer's Depot, No. 17 Buffalo st., Rochester, N. Y.

July, 1852,

M. F. REYNOLDS.

Real Estate for sale.

THE health of the subscriber having failed him, he is induced to offer for sale his Mill property, consisting of a custom Mill, recently put in a good state of repair; a Saw Mill, also recently repaired; two Dwelling Houses; a good Orchard, and about 22 acres of land, including fowling land. Said property is situated in the pleasant town of Yates, Orleans Co., N. Y., in the midst of a wealthy farming community and an excellent wheat growing country.

He has also a farm of 154 acres of first quality land adjoining said Mills, 120 acres improved, good buildings, orchards, and plenty of running water. He will sell said farm with the Mills, if desired.

Inquire of the subscriber, on the premises.

[7-3]

J. C. PARSONS.

SINGLE HORSE POWER AND CHURNING MACHINE.

This machine has been extensively used in large dairies and with the most satisfactory results. The power is found to be peculiarly adapted to churning, the propelling force being produced by the weight of the horse to an amount sufficient to drive 4 or 5 barrel churns. The motion is varied by altering the elevation of the power so as to produce all the changes in speed required in the different stages of the process of churning. This is done by means of a lever and without stopping the horse, so that the motion is always under the control of the person in charge. The power is the same as that made by us for threshing, &c.

WHEELER'S FEED CUTTER.

This machine is made expressly for Horse Power use, and is very strong and substantial. It cuts not only corn stalks, but hay and straw with equal facility, and does its work with great rapidity. Price, \$28.

LAWRENCE'S SAW-MILL.

This mill is much used on railroads, for sawing wood for locomotives, as well as by farmers, for cutting stove fuel. With a one horse power it will cut from 10 to 15 cords of wood twice in two per day. Price, (with 24 inch saw,) \$35.

WHEELER'S CLOVER HULLER.

This machine is compact, simple and durable. It does its work perfectly without injuring the seed, and is capable of hulling from 5 to 15 bushels of clover seed per day, with one horse. Price, \$28.

TROJAN PLOW.

The subscribers are also the sole agents in Albany for the sale of the celebrated "*Trojan Plow*," made by N. B. Starbuck, of Troy. These plows are doubtless superior to any other kind in use, and will be sold by us at the manufacturer's prices.

NOTE All machines made and sold by us are warranted to give satisfaction, or they may be returned after a reasonable time for trial. Orders are solicited and will be promptly filled.

WHEELER, MELICK, & CO.,

Corners of Hamilton, Liberty, and Pruyn streets,
(Near the Steamboat Landing,) Albany, N. Y.
August, 1852.

The subscribers have obtained from Messrs. Wheeler, Melick, & Co., of Albany, the exclusive sale in Rochester, and general agency in Western New York, of their celebrated Agricultural Machines, which we will sell at their Albany prices, adding transportation.

J. RAPALJE & CO.

Field Seeds.

AUSTRALIAN WHEAT—very superior. The berry of this grain is extra large, and makes the best of flour. It produces a greater average crop than any other variety now grown in New York. Several years' experience in its cultivation, proves that it is less liable to rust or mildew than other kinds; and as the stalk is large and strong, it is also less liable to blow down or lodge. Price, \$4 per bushel. Other varieties of wheat, such as the White Flint, Mediterranean, Black Sea, &c.

BUCKWHEAT, of the best kinds in market.
RUTA BAGA, or Swedish Turnep Seed. The Purple Top and other superior varieties.

TURNEP SEED—Large White Flat, Long White, Red Top Flat, Yellow Aberdeen, Yellow Stone, and other improved kinds for the field or garden. A. B. ALLEN & CO.,
June, 1852.—6-6f. 189 & 191 Water st., New York.

Improved Subsoil Plows.

THE subscribers offer for sale an Improved Subsoil Plow, made under the advisement of Prof. J. J. Mapes, and free from the objections urged against those formerly in use. The wearing parts are so arranged that they may be easily and cheaply renewed, while the amount of force requisite to move them is less than half that required by those previously made.

Price—One Horse Plow, \$5; with draft rod, \$6. No. 1, with draft rods, \$8.50. No. 2, do., \$11.

LONGETT & GRIFFING,
June, 1852.—6-6f. No. 25 Cliff street, New York.

Northern N. Y. Live Stock Insurance Company, Plattsburgh, N. Y. For terms, please apply to agents of the Company.

GREAT SALE OF BLOOD CATTLE.

ON Wednesday, the 18th of August next, I will sell the chief part of my large herd of Blood Cattle—chiefly cows, heifers, and heifer and bull calves—comprising upwards of fifty full-bred Short-Horns.

Also, eight thorough-bred Herefords—two years old bull, a yearling bull, three cows, and three calves. One of the Hereford cows ("Rarity") was imported from England by Messrs. Corning & Southam, in 1841. The others, excepting the two years old bull, are her descendants, by bulls of the same stock.

Also, two or three Devon bull calves, got by Mr. Ambrose Stevens' imported bull "Candy," bred by the distinguished Mr. Quarry, of Devonshire, England, and out of cows descended from the herd of the late Earl of Leicester.

The remainder of the cows and calves, forty to fifty in number, are high-bred Short-Horn grades, with a dash of Devon blood in some of them.

The calves of the thorough-bred Short-Horns and grade cows, are mostly got by the imported Short-Horn bull "Duke of Exeter" (10,152) of the celebrated "Princess tribe," bred by Mr. John Stephenson, of Durham, England, whose herd is excelled by none, if equaled, by any now in England.

All the Short-Horn and grade cows and heifers which come in season, will be bulled, previous to the sale, by "Duke of Exeter."

Many of the cows, both thorough-bred and grade, are descended from the Bates bulls "Duke of Wellington," imported by George Vail, Esq., of Troy, N. Y.; and by "Symmetry," son of "Wellington," out of Mr. Vail's imported Bates cow "Duchess."

This stock has been bred with a strict regard to their milking quality, in which they have been fully proved, and are not excelled by any herd of cows in the United States. They are all gentle, with fine silky udders, milk easy, and are animals that will be satisfactory to any one in want of the best breeding and milking stock.

The sale will take place at the residence of Peter Gurbane, two miles above Albany, on the Troy road, on the homestead farm of Gen. Van Rensselaer, where the cattle will be for a week before the sale.

Catalogues with pedigrees will be prepared by the 15th of June, and sent by mail to all post-paid applicants.

I will also sell at the same time, two pairs of six years old thorough-bred Short-Horn oxen, and two or three pairs of matched steers.

Also, ten or twelve South-Down buck lambs, got by an imported ram, from the unrivalled flock of Jonas Webb, of Babraham, England, and from Ewes descended from the flocks of Mr. Webb, and Mr. Eilman of Sussex.

LEWIS F. ALLEN.

Black Rock, N. Y., May, 1852.—6-31*

French Zinc Paint.

THIS new and beautiful article of Zinc Paint is now offered to the trade and public, ground in prepared linseed oil, for the first time in this country. It has been used successfully in France for the last five years, where it has superseded white Lead as a paint.

The French Zinc when properly prepared and used, makes the most brilliant and durable white in use, and is entirely free from all poisonous qualities.

The French Zinc is not more expensive than white lead, and is prepared in such a manner that it requires no farther preparation for use, than to thin it with Turpentine or raw Oil to the consistency of white lead paint.

The French Zinc is very much whiter, and has a better body, than the New Jersey Zinc.

The French Zinc is offered dry, and prepared as above, in quantities to suit purchasers, at the Manufacturer's Depot, No. 17 Buffalo st., Rochester, N. Y.

July, 1852,

M. F. REYNOLDS.

Real Estate for Sale.

THE health of the subscriber having failed him, he is induced to offer for sale his Mill property, consisting of a custom Mill, recently put in a good state of repair; a Saw Mill, also recently repaired; two Dwelling Houses; a good Orchard, and about 22 acres of land, including fowling land. Said property is situated in the pleasant town of Yates, Orleans Co., N. Y., in the midst of a wealthy farming community and an excellent wheat growing country.

He has also a farm of 154 acres of first quality land adjoining said Mills, 120 acres improved, good buildings, orchards, and plenty of running water. He will sell said farm with the Mills, if desired.

Inquire of the subscriber, on the premises.

[7-53]

J. C. PARSONS.

**Emery's Patent First Premium, 1852,
RAILROAD HORSE POWER,
THRESHING MACHINES, SEPARATORS, &c.,
Western New York Agency.**

**E. D. Hallock, Agricultural Warehouse,
No. 50, STATE ST., ROCHESTER, N. Y.**

THE Subscriber, late from the Albany Agricultural Works, Warehouse, and Seed Store, where he has been engaged for the past six years, has secured the sole Agency for the sale of Emery's Patent Railroad Horse Power for Rochester and vicinity, so widely and favorably known throughout the country, and which has, without exception, taken every highest premium awarded in the States of Ohio, Michigan, and in New York, for the best Railroad Horse Powers, in 1850, 1851, and again in 1852, also at the Provincial Fair of Canada, recently held at Toronto, was awarded a Diploma and £2, of which the judges highly commend the principle and workmanship of this Power, now offer them at manufacturer's prices, with the transportation added, and subject to the warrantee as follows:

"To work to the satisfaction of the purchasers as represented in Circulars and Catalogues, or to be returned within three months and full purchase money to be refunded."

For further particulars see Circulars and Catalogues, which are furnished gratis on application to the subscriber.

The attention of the Farming public is solicited, and a careful investigation into the construction of this Power, and its comparative merits, as well as price, is requested before purchasing elsewhere.

The Wheeler Power is also offered ten dollars cheaper than heretofore by any other agency, and subject to same warrantee as given by others for the same kinds. Samples will be kept constantly on hand, and to insure promptness and avoid disappointments in supplying them, farmers are requested to send in their orders at as early a date as possible.

He will keep for sale, Emery's Seed Planters, the best in use: Circular and Cross Cut Saw Mills, Feed Mills, Corn Stalk and Hay Cutters, Corn Shellers, Churning fixtures, &c., adapted to the Power.

Also, Reapers, Mowing Machines, Grain Drills, Plows, Harrows, Cultivators, Corn Shellers, Hay Cutters, Fan Mills, and agricultural and horticultural implements generally. He will be prepared to furnish dealers with Dunn and Taylor's well known Scythes: also, Manure, Straw, and Hay Forks, Smuths, Rifles, and other haying tools, at manufacturers' prices, wholesale and retail.

Particular attention is called to a **NEW PLOW**, which is believed to be the best cast-iron Plow ever offered, and which is warranted to do better work, with less expense of team than any plow heretofore sold in this vicinity, while the price is less than for any other equally well finished.

The "uniform one-price, cash system" will be adopted, with the prices as low as the cost of articles and just compensation for labor and time will allow. Farmers and others are invited to call and examine the stock of Machines and Implements,—and are assured no effort shall be wanting to meet promptly the wants of a discriminating public. [11-f] **E. D. HALLOCK.**

Important to Fruit Growers.

THE subscriber having been for a number of years engaged in rearing and experimenting with Fruit and Fruit Trees, now offers the result of his observations to the public. He has discovered a certain substance which, if applied to Fruit Trees, renders both their trunks and foliage obnoxious to vermin. The Yellows, in the Peach tree, is permanently cured by one or two applications. He has also discovered a cheap and successful mode of preserving fruit during the winter, or for an indefinite period, entirely free from rot.

Persons wishing to avail themselves of these discoveries, by enclosing *One Dollar* in a letter to **J. W. WILLIAMS, Pottstown P. O., Montgomery Co., Penn.** will receive the mode of application by return of mail.
November, 1852.—*2

Superphosphate of Lime.

THE genuine article, manufactured by C. Durburg, in bags of 150 lbs. each. The subscribers have made a contract for a large quantity. We are now prepared to supply any quantity that may be ordered. Farmers and gardeners would do well to call on us before purchasing elsewhere, as we are now able to sell for a less price than heretofore offered. Every bag is branded "C. Durburg, Extra, No. 1." **LONGETT & GRIFING,**
State Agricultural Warehouse, No. 25 Cliff Street, New York. [11-f]

**NEW YORK STATE
AGRICULTURAL WORKS.**

Wheeler, Melick, & Co.

WILL, at the shortest notice, fill all orders for Machines made by them, among which are their Double and Single Horse Powers and Overshot Threshers and Separators, Combined Threshers and Winnowers, Circular Saw Mills, Clover Hullers, Horse Powers geared for Churning, Feed Cutters for Horse Power use, &c., &c.

The scarcity of fodder which prevails in many parts of the country in consequence of the present dry season, induces them to call the especial attention of farmers to their

Wheeler's Pennsylvania Feed Cutter,

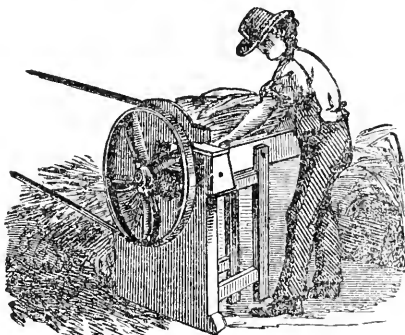

as being peculiarly adapted to the emergency.

This Machine is made expressly for Horse Power use, and is very strong and substantial. In Pennsylvania it is used chiefly for cutting corn stalks, although it cuts straw and hay equally well, and will cut from half an inch to two inches in length. It is simple and compact, having four plain, straight knives which are attached in such a manner that they may be taken off and ground, and then replaced without producing the least variation. All the wearing parts are made so that they can be adjusted by means of screws, with a common wrench, and any person can keep the Machine in the most perfect order. In cutting corn stalks they are crushed between strong iron feed rolls, and being cut short, the coarse stalks are split into small pieces, which reduces the whole to very fine feed. They are capable, with one horse, of cutting 150 bu. per hour.
Price, \$28. **WHEELER, MELICK & CO.**
Corner of Hamilton and Liberty Streets.

Albany, Nov., 1852.

GENEVA NURSERIES.

Fruit and Ornamental Trees and Seedlings.

PEAR SEED, APPLE SEED, &c., &c.

W. T. & E. SMITH desire to call the attention of Nurserymen, Dealers, and Fruit Growers, to their large stock of Thrifty and Well Grown Fruit and Ornamental Trees, suitable for Garden, Orchard, and Ornamental planting.

40,000 Apple, large and thrifty.

15,000 Peach, 2 years old.

8,000 Pear, standard and dwarf.

20,000 Cherry, standard and dwarf.

16,000 Orange Quince, 4 years old.

8,000 Horse Chestnut, 6 to 8 feet high.

10,000 Mountain Ash, 6 to 8 feet high.

4,000 Evergreens.—Balsam Fir, Norway Spruce, and Austrian Pine.

2,000 Grape Vines, mostly Isabella.

3,000 Plum, Apricot, Nectarine, and Almond.

10,000 Basket Willow Cuttings

20,000 Apple Seedlings, 1 year old.

10,000 Cherry Seedlings.

25,000 European Mountain Ash, \$3 per 1000.

3,000 English Thorn, for Hedges.

2,000 Privet, for hedges and screens.

20,000 Horse Chestnut, \$3 per 1000.

1,000 Downing Colonial Rhubarb.

Strawberries, 39 varieties; Roses, Dahlias, Gooseberries, Currants, Raspberries, Asparagus, Roots, Pie Plant (Early Lemon), Pear Seed, Apple Seed, &c. &c.
November, 1852.—*2

Prices of Agricultural Products at the Principal Markets in the United States. — Oct. 23, 1852.

	New York.	Boston.	Rochester.	Chicago.	Cincinnati.	Philadelphia.
Beef, per 100 lbs.	\$5.00 a 5.50	\$6.00 a 9.00	\$5.50 a 6.00			
do mess, per bbl.	9.50 15.00	12.00 14.00	10.00 10.50			
Pork, per 100 lbs.			6.50 7.00	5.00	\$5.00 5.50	
do mess, per bbl.	17.00 17.12½	19.50	16.00 19.00	18.00 20.00		18.50 19.00
Lard, per lb.		11¾ 12	9 10	10 11	10 a 11¾	12 12½
Butter, do	16 25	24 24	18 20	15 16	12 15	12 14
Cheese, do	8 9½	7 9	6 7	5½ 7	7 8	
Flour, per bbl.	4.50 5.87½	4.62 5.75	4.50 4.75	2.50 3.50		4.87½ 4.87½
Wheat, per bush.	85 1.12½	90 1.15	93 94	68 72	57 60	96 96
Corn, shelled, per bu.	75 76	68 76	62½ 62½	50 50	40 42	42 74
Rye, do	85 80	85 85	56 62	52 53	48 53	85 85
Oats, do	42 46½	44 50	34 34	38 28	31 27	28 34
Barley, do	72 77		62½ 48	52 52	45 50	
Clover seed, do	8 pr. lb.	8 a 11 per lb.	5.50	12 per lb.	4.00 5.00	5.00 5.12
Timothy seed, do	\$16 per tee.	3.00 3.50	2.50 2.63	2.25	1.75 2.00	2.37½ 2.75
Flax seed, do	1.30 1.40		1.25 1.37	1.25	2.00	
Hay, per ton	20.00 22.50	20.00 24.00	10.00 15.00			
Wool, per lb.	36 52	35 50	30 40	22 36	23 45	37½ 60
Wood, hard, per cord		6.00 6.50	3.50 4.50	3.00 4.00		

CONTENTS OF THIS NUMBER.

The Future of the Genesee Farmer, 329
 Wheat Culture, 330
 The Wants of Social and Domestic Life, 332
 Beauty and Value of Forest Trees, 333
 Wintering Cattle and Horses, 334
 Fattening Cattle and Sheep in Winter, 336
 Prepare for the Storm, 338
 Improvement in Farm Gates, 339
 CONDENSED CORRESPONDENCE.—Mulching Potatoes; A Singular Fact; Oregon Peas, &c.; Woolen Rags as Manure, 340
 Agricultural Productions, 341
 Cotswold Sheep, 345
 LADIES DEPARTMENT.—Flowers and Flower Seeds, 352
 EDITOR'S TABLE.—Notices, &c., 353
 Inquiries and Answers, 354

HORTICULTURAL DEPARTMENT.

Culture of Dwarf Fruit Trees, 346
 Number of Plants on an Acre, at given distances apart, 347
 Garden Hints for November, 348
 New French Cherries, 349
 Western Exhibitions, 350
 Annual Fall Exhibition of Gen. Valley Hort. Society, 351
 Acknowledgements, 351
 Answers to Correspondents, 356

ILLUSTRATIONS.

Woolman's Improved Farm Gate, 359
 Cotswold Ram, 344
 Cherry, Bigarreau Esperin, 349
 do. Cerise de la bernardiere, 349
 do. Bigarreau Marcellin, 349
 do. Guigne precoce de Tarascan, 349
 do. Duchesse de Gahna, 350
 Dwarf Convolvulus, 352

ANDRE LEROY,

Nurseryman, at Angers, France,

HONORARY and Corresponding Member of the principal Horticultural Societies of the United States and Europe, begs leave to inform his friends and all the Nurserymen of the Union in general, that he has made large preparations and has now on hand, a considerable stock of the finest Evergreen Seedlings, Roses, Fruits, and Ornamental Trees, &c. &c., most suitable for the American market. The experiments of several years, of putting up large orders for the United States, enables him to flatter himself that he has now all the necessary knowledge to give full satisfaction, and to insure the delivery, in good order, of all the Trees, &c., ordered.

He also begs to inform all Nurserymen, who have not already received the supplement for 1852, to his Catalogue for 1851—that it can be obtained free of any charge at his Agent's office, M. Ed. Bossange, 138 Pearl St., New York, who will also attend to forwarding all orders sent to him, and to pass through the Custom House; and re-ship all goods ordered without any delay and with the greatest care.

Address M. ANDRE LEROY, Angers, France, care of ED. BOSSANGE,

[11-21] 138 Pearl Street, New York.

Sausage Cutters and Stuffers.

A VERY superior article, made of wood and iron, that will cut from 70 to 100 lbs. per hour. Price \$4, \$5 and \$8 each. For sale by LONGETT & GRIFFING, [11-31] No. 25 Cliff St., New York.

Premium Dahlias.

THE subscribers offer for sale this Autumn and the ensuing Spring, 10,000 Dahlia Roots, which have proved to be the choicest collection in the States and Canadas. [See records of the Fairs for the last four years.]

Persons commencing the Nursery business, and Amateurs, will find it to their advantage to give us a call, or make enquiries before purchasing elsewhere.

C. J. RYAN & CO.,

Rochester and Charlotte Plank Road Nurseries, Rochester, N. Y. [11-14]

For Sale.

ONE of the desirable farms in the Chenango Valley, situated two miles from the village of Oxford, containing 220 acres, river flat—grain land, pasture, wood land, and orcharding. A large and convenient dwelling house, two large barns, with sheds and out-houses. Watered by the Chenango river, a creek, (on which is a saw-mill) and by never-failing springs. On it are more than seven hundred rods of stone wall. Persons wishing to purchase, are desired to look at the crops and stock on the farm. Inquire of JOHN TRACY, Oxford, N. Y. Oct., 1852.—10-21*

Important to Farmers.

IT IS generally conceded by all intelligent farmers that cutting the food for cattle will save from 25 to 30 per cent. Berthoff's Oblique Rotary Corn Stalk, Hay and Straw Cutter, is conceded by all that have used it to be far superior to any other, as it destroys all hard substances in the stalk leaving it soft and easily eaten. It turns very easy and is not liable to get out of order, and, with care, will last an age. It has been awarded Four First Premiums and a Silver Medal, by the American Institute. For further particulars address (post paid) the patentee, H. W. BERRHOLL, Sugar Loaf, Orange Co., N. Y., or LONGETT & GRIFFING, 25 Cliff St., New York, who are agents. Patent rights for sale. [11-31]

BOOK AGENTS WANTED.

GOOD salesmen can earn from \$1 to \$3 per day, in selling

AGRICULTURAL BOOKS, POLITICAL CAMPAIGN BOOKS, LARGE AND SMALL BIBLES,

POLITICAL AND OTHER PICTURES,

Uncle Tom's Log Cabin; Uncle Tom as it is; Northwood, Mrs. Hale's new book; Cheap Publications; Gold Medals, Gen. Scott and Gen. Pierce; together with other new books.

I will furnish agents with from \$15 to \$30 worth of books for cash, and take back all the unsold books and refund the money. Agents can make from 25 to 100 per cent. profit, and in this way are not compelled to keep their stock if not sold. Books can be sent by Express to any address. Money can be safely sent by mail. Address D. M. DEWEY,

Oct., 1852. Arcade Hall, Rochester, N. Y.



GENESEE FARMER

VOL. XIII.

ROCHESTER, N. Y., DECEMBER, 1852.

No. XII.

THE PHILOSOPHY OF TILLAGE—HORSE-HOEING WHEAT.

If one were asked to name the practical farmer, who, of all men from Adam down to the present generation, had most successfully studied the Philosophy of Tillage, he might without hesitation claim the distinguished honor for JETHRO TULL, the inventor of drill husbandry, and the first to cultivate wheat by means of horse hoes. This great man can be best introduced to the reader, and the date indicated when seed-drilling commenced, by allowing him to speak for himself:

“About the year 1701, when I had contrived my drill for planting sainfoin, I made use of it for wheat, drilling many rows at once, which made the work more compendious, and performed it much better than hands could, making them of a foot distance. Drilling in the seed and covering it did not all amount to sixpence per acre expense, which was about ten times over-paid by the seed that was saved; for one bushel to an acre was the quantity drilled. There remained no need for hand work but for the hoeing, and this did cost from half a crown to four shillings per acre. * * * This was such an improvement to land, [the hand-hoeing of drilled wheat,] that when one part of a strong whitish ground, all of equal goodness, and equally fallowed and tilled, was dunged and sown in the common manner, and the other part thus drilled and hand-hoed, without dung, the hoed part was not only the best crop, but the whole piece being fallowed the next year, and sown all alike, by a tenant, the hoed part produced a so much better crop of wheat than the dunged part, that a stranger would have believed, by looking on it, that that part had been dunged which was not, and that part not to have been dunged which really was.”

While engaged in drilling and hand-hoeing wheat, in the early part of the 18th century, this illustrious farmer invented a valuable substitute for hand hoes which he called a “horse hoe,” as it was worked by horses or oxen, like a common plow or cultivator. At that early day, little arable land was artificially drained in England, and wheat required to be grown on narrow and comparatively high beds to avoid damage from an excess of water in the soil. Mr. TULL laid his summer fallows, or stubble grounds, on which wheat was to be sown, in beds that were from five to six feet from center to center, and quite crowning. Along the middle of each bed he drilled from two to four rows of wheat—usually three—and eight or ten inches apart. At eight inches distance between the rows, only sixteen inches would be occupied on the ground by three rows,—one on each side of the center row and eight inches from it—leaving four feet and eight inches between the wheat in one bed and that in another. This was the widest central space ever allowed; and thirty inches the least that would well permit the use of the horse hoe, which might be called a cultivator, or shovel plow, or two-share plow; for during his forty years’ practice and experimenting, the form and character of his tillage implements were often changed and improved.

The genius of this inventor prompted him to investigate and master the true principles of cultivating the earth. He plowed and hoed his growing wheat, and often stirred the ground, not because others tilled it, but to accomplish a clearly understood, and truly philosophic purpose. What was this purpose? It was not to imitate nature in

the production of plants, for she never plows, nor harrows, nor hoes the earth to obtain her most abundant fruits. His policy was purely a theory, or the ideal of a close thinking mind. He viewed and contemplated soils in this light: A square foot of impervious earth presents only 144 square inches to the chemical action and mellowing influence of the atmosphere. If a cubic foot of this solid earth was exposed, then six sides in place of one would come in contact with the air, and bring 864 square inches instead of 144 under the control of aerial powers. If this mass of earth were cut up into cubic inches, it would form 1728, each of which would present six sides to atmospheric agencies, making an aggregate surface of 10,368 square inches. In each of these cubic inches there are 1728 cubic lines, each of which would present six equal surfaces, and be, like the cubic foot, equally capable of subdivision; and so on *ad infinitum*. TULL saw that tillage does no more than comminute the soil; and that this pulverization really makes the desired pasture for the roots of all cultivated plants.

If it be in our time profitable, and a general practice to stir the earth above and near the roots of maize, which is a cereal, with a plow, cultivator, or hoe, may not growing wheat plants be cultivated, or horse-hoed, with equal benefit? On this point we have no doubt whatever. The soil between rows of rice (another cereal,) is profitably cultivated, as it is in the production of both sweet and Irish potatoes, in the culture of tobacco, cotton, sugar-cane, beans, peas, and garden vegetables. What is the full meaning, what the occult changes in the soil, wrought by the most perfect tillage?

First, It enables the arated mold, loam, or clay and sand, to absorb and condense from the atmosphere all the gaseous elements of crops, and particularly ammonia. When plants and animals die and rot on the ground, as they ever do in a state of nature, a large portion of their weight and substance is diffused through the air in well known gases. Hence it is that the atmosphere is charged with the food of plants, and may, when wise farmers shall know how to command this food, feed growing grain and roots for indefinite ages. That vegetable mold, mellow loam, and well pulverised clay, do absorb all the combustible elements of crops from the atmosphere, is not to be disputed. The only debatable points are the condition of the soil most favorable to the condensation of gases, and whether *it will pay* so to till the ground on which wheat plants are growing in straight rows as to depend mainly or wholly on the atmosphere for carbonic acid, nitric acid, and ammonia. To eliminate potash, soda, lime, and magnesia, from their insoluble silicates in the debris of rocks, from which the staple of all soils is derived, they need a good deal of what is technically called organic matter, viz: ammonia and carbonic acid. Hitherto intelligent farmers have depended on vegetable mold and manure for solvents of the silicates, phosphates, chlorides, and sulphates of alkalies and alkaline earths, so necessary to supply the incombustible, inorganic part of plants, which is called ashes when they are burnt. But adopting both the theory and practice of TULL, with slight modifications, induced by the light of modern science and discoveries, experiments are now being made in England, with every prospect of success, to draw all, or nearly all, the organic food of growing plants from the air, without the aid of guano, or manure of any kind. TULL's leading idea was, that the cheapest manure in the world exists unseen and mostly in a latent state, in the soil and atmosphere, and in quantity sufficient for all practical purposes in all coming time. The soundness of this view must depend mainly on our success in drawing ammonia and carbonic acid, and, perhaps, chlorine, sulphur, and phosphorus, (which abound in a volatile and gaseous condition,) from the atmosphere.

The Rev. S. SMITH, of Lois-Weedon Vicarage, in Northampton, England, has succeeded in growing six or eight successive crops of wheat on the same acre, without any other manure than such as a soil finely tilled, twenty inches in depth, abstracted from the atmosphere. Of course many more years must elapse before the enduring advantages of this Tullian system can be fully demonstrated.

Mr. HOSKYNs, who has recently visited Mr. SMITH's experimental field, stated to the Council of the Royal Agricultural Society that the results were only so wonderful that they did not receive the credit they deserved; although when personally inspected, they carried at once a conviction of their perfect feasibility, notwithstanding the marvellous absence of all manure, as technically so understood, in the carrying out of his simple but effective process. Others have seen the Reverend gentleman's experiments; and among them Mr. GADESDEN, who thus bore testimony before the Council: "The soil was a stiff one, and so stiff that Mr. SMITH's own tenant farmer expostulated with him in reference to the circumstance; but although no manure had been used, it had *become so fertile* that it would be necessary to cast off the top staple and bring up the clay. Mr. SMITH had six acres in wheat, and intended to extend this system of cultivation to twenty. He understood that the Earl of Essex had fifty acres on the same system."

Mr. JOHN M. PAINE "could simply, but entirely, confirm all that Mr. HOSKYNs had said with regard to Mr. SMITH's experimental wheat fields under the Tullian mode of culture as practiced by him. He would, however, very briefly state what he saw, and the impression which Mr. SMITH's crops left on his mind. The first time that he saw them was immediately after inspecting Mr. LAWES' experimental wheat at Rothamsted, about the last day of June. He had thus a good opportunity of forming a comparison of the appearance of the respective crops at that time. Mr. LAWES' highly manured nitrogenous plots were then looking splendidly well. Mr. PAINE had also some of his own similarly manured, which was likewise very promising, and which did realize from seven to seven and a half quarters per acre—*i. e.*, from 56 to 58 bushels. He had thus in his mind's eye some very good standards of comparison, and he was bound to state that Mr. SMITH's *far exceeded either of them* [his own and Mr. LAWES'] in luxuriant appearance and promise of a crop. When he first beheld them, he could not help exclaiming, 'This land has been lavishly dressed with ammoniacal manure.' And so, indeed, it had been from atmospherical sources; for this we knew and could appreciate, after Mr. WAY's most valuable discovery of the absorptive and retentive powers of clay soils." Mr. PAINE's remarks throughout were alike instructive and interesting, but our quite limited space forbids further quotation without condensation. He could perceive nothing peculiar in the geological structure of the land at Lois-Weedon which would lead one to infer that Mr. SMITH's success in producing seven consecutive crops was at all attributable to that cause. It was manifestly what would be good wheat land when well drained and well cultivated. With common management, the surrounding country did not produce large crops.

On land which had been cropped several years without manure, Mr. PAINE drilled a half bushel of wheat per acre, on the 9th of November, 1851, on the Tullian plan. It could not be done earlier for reasons that need not be stated. Wheat barely got fairly up before frosts and winter, and looked thin and badly, and could not be trenched before March. The ground was then broken eighteen inches deep between the rows, and some of the subsoil brought to the surface. The rows had been hoed, and at that time the whole field had a most luxuriant and promising appearance; although like Mr. SMITH's it had too gross an aspect than otherwise. As the experiments now stand, the best returns may be expected by planting three rows of wheat within a space of twenty inches, making a central row and one on either side ten inches distant, and then leaving, as in planting corn in this country, an interval for the roots to spread and imbibe nourishment, of thirty inches.

So far as the principles of tillage are concerned, the difference between maize and wheat is not worth writing about. In neither should the plants stand too thickly, and in both their roots should have a deep, permeable, and rich pasture to secure a generous harvest. Thick and thin planting are terms too indefinite for scientific use. Ten years ago we urged upon the attention of wheat growers this view of seeding land to wheat,

and feeding the young and needy plants until they arrive at full maturity. One may have just food enough to rear and fatten two pigs, and with proper care and skill he may have each gain a pound a day in weight for three hundred days. If he shall attempt to rear and fatten four pigs instead of two, they may be grown; but to fatten them is out of the question. After they have reached a certain size, to keep so much flesh and blood alive, and from losing weight, will consume all the food within their reach, and of course such consumption is without profit to their owner. This waste of food and of time lessens the amount of meat and fat produced full fifty per cent; for the four pigs must live all their allotted days, and eat every day, although they grow but half of the time, and only half grow while about it. What is true of four pigs, is equally true of four or five million wheat plants, pastured on a supply of nutriment equal to the full development of just half the number. You get a little more straw, more vegetable bone, (silicates) and a greater number of heads, or ears of grain; but beyond all question, nature gives you fewer and smaller seeds, less flour and less gluten and starch for bread.

This brings us to the subject of agricultural physiology — one on which, strange to say, no book has ever been published in the United States. Wheat culture is inseparably blended with the deep science of feeding, rearing, and fattening all living things on the farm. If we were asked what crop is best cultivated in this country, we should answer that it is not wheat, nor corn, nor tobacco, nor potatoes, but cotton. The cleanest culture in the United States may be seen in cotton fields, which have been properly plowed, hoed, "chopped out," and otherwise fairly attended. TULL chopped out his young wheat with hoes whose blades were only four inches long, having a sharp thin edge. He would be regarded in Western New York as a large wheat grower; and forty years' experience taught him the extreme folly of having a poor pasture in the soil, and too many plants to the square yard. Subsoiling he did not understand by name; but no other agricultural writer ever complained so much and so earnestly of his neglectful plowmen who would not do justice to his wheat beds — stir the earth deep enough and make it fine enough, nor roll it properly between the rows. The surface of tilled ground needs compression, for wheat.

BARN-YARD MANURE.

THE liquid and solid excrements of animals contain all the elements of plants in a state best suited for assimilation, and the great practical question of the farmer is how to preserve them without loss and apply them to the land in the best condition. Our present system of barn-yard management is most objectionable; by it the greater part of the liquid excrements are lost, and by injudicious fermentation a large quantity of the organic gases escape, and the soluble, and consequently most valuable, portion of the manure is washed away by drenching rains. These three evils every one familiar with farm management must have observed. The loss to the individual by such a reprehensible practice is great, and, viewed as a national evil, is most appalling. The direct loss to the farmers themselves, in the aggregate, is immense; while the indirect loss to the country is positively inestimable.

No farming can be profitable where the manure is thus shamefully wasted; nothing being plainer than that the crops of the farm and the profits of the farmer are in direct proportion to the amount and value of the manure made on the farm. The great aim of the farmer in the management of barn-yard manure, should be—first, To preserve all the liquid; Second, To keep up a slow fermentation, never letting the heap heat or ferment violently, and thus throw off its ammonia; Third, To prevent leaching during heavy rains and melting snows.

The first is perhaps the most difficult; and tanks for the reception of the liquid are often recommended and adopted by first rate farmers, and we wish there was a good tank in every barn-yard in the land; yet we think that much may be done by covering the bottom of the yard with dry peat, muck, saw dust, waste straw, potato vines, and numberless other absorbent substances which can be found on most farms, and which, valueless in themselves, can, thus be made into enriching fertilizers. If this be done and the yard be kept constantly supplied with waste straw, the heap will absorb all the liquid of the animals and what may fall in rain on its surface. If it will not, a tank, or water tight pond, should be placed in a convenient place in the yard and the superabundant water of the rainy season be preserved for pumping back on the heap in a dry period. If this liquid be kept saturated with sulphate of lime, or refuse common salt, it will be of great value to the manure, inasmuch as plaster will, in its liquid state, change the volatile carbonate of ammonia into the fixed salt, sulphate of ammonia.

The second object, or keeping up a gradual and not too rapid decomposition, is very easily attained. If horse or sheep manure be thrown up loosely, so that there is a free admission of air and moisture, rapid and most injurious decomposition takes place with the evolution of ammonia, carbonic acid, and water. This burning process (for it is nothing less than a slow process of actual combustion) may be allowed to go on till the heap is greatly reduced in size, and what is left be comparatively worthless. On the other hand, if the hog and cow manure be thrown in a solid heap, little or no decomposition takes place, and the manure remains in a raw and unsuitable state for direct application to rapidly growing plants. The object of the farmer, therefore, should be to mix these several manures together, so that the horse manure, &c., shall act as a ferment, and induce the desired decomposition of the hog manure, &c. In this way they will counteract each other, and the heap by spring will be in first rate order for direct application to the corn, potato, or other crops. Sheep do not like to lie on a fermenting manure heap. They should, if possible, have a separate yard to run in at night, and the manure they make be hauled to the heap as often as practicable, fresh straw being supplied in its place. It is generally necessary that sheep and cattle should run on the manure heap so as to compress it and prevent too rapid fermentation.

The third condition necessary to preserve the valuable elements of manure is to prevent leaching. This can be accomplished by having all the buildings round the yard spouted, and the water conducted away without falling on the manure. If this is done, the water falling on the natural surface of the heap will not usually be more than the manure can absorb; if it is, as we have before said, it should be preserved—saturated with plaster and conveyed back to the heap in dry weather.

We believe if these three conditions were attended to in the manner we have mentioned, or in some other way better suited to individual situations, the value of the manure on most farms would be at least doubled.

In conveying the litter from the stable, cow-house, and pig-pens, a good large farm yard wheelbarrow is absolutely necessary. Indeed, we think a wheelbarrow is one of the most essential vehicles to the proper management of a well-conducted farm establishment—a one horse lifting cart standing next in our estimation. Both are needed to perform much necessary work in the most economical manner.

We have said nothing about the condition in which it is best to apply manure, whether in a fermented or unfermented state, about which there is much difference of opinion, not only among chemists, but among farmers themselves. There is necessarily a loss during the fermenting process; but if it is confined to water and carbonic acid, the loss to the farmer is of little or no consequence. And if the heap is managed as we have directed, and especially if saturated solutions of plaster are frequently pumped and re-pumped on the heap, little of the ammonia need escape. In such a case the more the heap is reduced by fermentation, the less labor will be required to haul and spread

it; while from its concentrated *soluble* character (for many of the mineral substances are increased in solubility by fermentation with organic matter) it acts much quicker, and with more effect, on spring crops than though applied in the green state.

On heavy clay soils it is often advantageous to apply the manure in the green state, the carbonic acid generated by the fermentation of the litter in the soil assisting materially the solubility of silicates and other nearly insoluble salts. It increases, also, the porosity of the soil, and thus benefits it mechanically as well as chemically.

IMPROVED SUPERPHOSPHATE OF LIME.

Most of our readers are probably aware that the Royal Agricultural Society of England offered some months since a premium of \$5,000 and a gold medal for a chemical manure which shall be equal in value to Peruvian guano, and which can be afforded for \$25 per ton, gross.

In the August number of the *Farmer* we mentioned having received two articles of superphosphate of lime made in New York, one under the direction of Prof. MAPES, editor of the *Working Farmer*, called "Improved Superphosphate of Lime;" the other by DEBURG, called merely "Superphosphate of Lime." We there gave our opinion of their respective value as compared with each other, and with Peruvian guano, thinking that DEBURG's was the better article as a manure for turneps and other root crops, but that for wheat, corn, and other cereals, Peruvian guano was very much superior to either.

This "improved" superphosphate of lime has been advertized in a great number of the agricultural papers, and many of our brethren, from confidence in Prof. MAPES' integrity, knowledge, and skill, as one of our first agricultural chemists, have, probably without trial or good evidence, recommended it to their readers. We hold it most important that at the present time, when there is evidently an awakening interest in scientific investigations, and the recommendations of chemists, that everything that will in any way mislead the farmer, or that will give him exaggerated ideas respecting the value of any chemical compound when applied to his crops, should be fearlessly exposed.

Prof. MAPES, in the November number of his paper, after noticing the premium above mentioned, says:

"The Royal Society may offer this premium with impunity, so long as the prices of bones, sulphuric acid, and ammonia shall remain as they now are. Long experience has now taught the English farmers that superphosphate of lime and sulphate of ammonia, when properly prepared, is worth nearly twice its weight of Peruvian guano; and attempts have been made to manufacture an article containing these requisites in proper proportions, and in a dry form, at £20 per ton, at which price it could readily be sold, but the high price of phosphate of lime and of sulphate of ammonia, has rendered this impossible, and the Royal Society may offer their premium fearlessly, until it can be proved that crops may be grown from other substances than those contained in them as proved by analysis.

"The Improved Superphosphate of Lime, used by us for the last five years, and now made for sale at \$50 per ton at New York, cannot be duplicated in England for double that sum, and if it could, to our certain knowledge it would be done, and would soon take precedence of Peruvian guano at the present prices.

"Even the American native phosphate of lime is selling in England at £7 (\$35) per ton, in large masses, the grinding of which to a powder is attended with large expenses, and even when ground it is useless as a manure, until treated with half its weight of sulphuric acid, thus rendering the prepared article in a perfectly dry state, costing much more than the cost of the Improved Superphosphate of Lime, which, from the absence of ammonia and many other of the constituents of guano, it is very far inferior to it in quality. It will readily be perceived that the Royal Society will not soon be called upon to pay over the £1000 so liberally offered."

We have had some considerable acquaintance with English farmers, and have always considered them by no means an intellectual class of men, but we never thought them such fools as the above hypothesis of Prof. MAPES makes them. If "long experience" has taught

them that phosphate of lime and sulphate of ammonia, in the proper proportions, are worth twice as much as Peruvian guano, why do they buy upwards of 151,000 tons of guano a year and pay \$45 per ton for it, when they can buy burnt bones, or animal charcoal for \$18 per ton, and sulphate of ammonia for \$60; for we presume "the proper proportions" of Prof. MAPES would give much more of the phosphate of lime than of the sulphate of ammonia, so that this manure, of phosphate of lime and ammonia, could be made for less money than the guano. And if long experience has taught them that it is worth twice as much as guano, it is surprising that they use so much guano and so little of the mixture—so little, indeed, that we have never heard the manure mentioned. The assertion that such a manure "sold readily" at \$100 per ton, but cannot be made for that sum, is most certainly a mistake.

Muriate of ammonia sells readily at \$100 per ton, and from the high per centage of ammonia it contains, it is a cheap manure at that; but an addition of phosphate of lime would *reduce its value* in exact ratio as it was mixed with it. That this is the case, is most obvious from the fact that ammonia cannot be purchased in any portable form for less than twelve cents per pound, whereas phosphate of lime can be obtained in unlimited quantities as a mineral phosphate for less than one cent per pound, and in animal charcoal for thirteen mills per pound, and the price is gradually falling—large quantities, the refuse of beet sugar manufactories, which are now in a very flourishing condition, being sent over from Germany and France.

Sulphuric acid can be purchased in London for less than half what it costs in New York, and sulphuric acid is *the expensive ingredient* in the manufacture of superphosphate of lime. Such being the facts, what becomes of Prof. MAPES' assertion that his improved superphosphate of lime cannot be duplicated in England for less than twice its cost in New York.

According to an analysis now before us of "MAPES' Improved Superphosphate of Lime," by THOMAS ANTISELL, M. D., New York, it appears that 53 lbs. in the 100 of this manure consist of burnt bones or animal charcoal *little acted on by the sulphuric acid*, the value of which, in New York, would be about \$10 per ton; the other 47 lbs. contain about 22 lbs. phosphate of lime, 8 lbs. sulphuric acid, half a pound epsom salts, 4 lbs. water, 3 lbs. lime and silica, and 10 lbs. organic matter and alkaline salts soluble in water. If such is the composition of the "improved superphosphate of lime"—and judging from the appearance of the article, we have no doubt of the correctness of the analysis—to say that such a compound cannot be made in England at \$100 per ton, is at best supremely ridiculous. We think we could manufacture such an article there for \$30 per ton and realize a handsome profit at that; though we doubt the possibility of selling it for \$20 per ton, unless, indeed, we started an agricultural paper and devoted its pages to puffing the stuff. And, even in that case, we should need a *new* list of subscribers each year; for though English farmers are not very bright, they do not patronize the same humbug more than once.

In another part of the same number of the *Working Farmer*, Prof. MAPES, speaking of the large orders received for this manure this fall, says:

"The old wheat districts are again profitable where the Improved Superphosphate of Lime has been applied; all agree with our former statements, that 500 lbs. of the new manure is as effective as 40 half cords (two-horse wagon loads) of well rotted stable manure, while its cost does not equal the mere expenses of handling the barnyard manure."

We have repeatedly advised our readers to make as much manure on their farms as possible. If they have done so, it appears it will be good economy to give it to some of their unscientific, book-despising neighbors, and send to New York and get 500 lbs. of "MAPES' improved phosphate of lime" to supply its place. Verily, this great discovery bids fair to revolutionize the established practice of agriculture.

"THEORIES EXAMINED AND EXPLAINED."

MR. LEVI BARTLETT, the associate editor of the *Boston Journal of Agriculture*, in a reply to our remarks on his series of articles headed "Theories Examined and Explained," thus writes in the November number of the *Journal* :

"MR. KING:—Last evening I received through the Post Office, the October number of the *Genesee Farmer*, which some one has kindly forwarded to me. The paper contains some severe strictures on two or three communications I have furnished for several of the last numbers of the *Journal*. The article in the *Genesee Farmer*, I presume, was written by Dr. LEE, one of the editors of that paper. I regret that he did not wait till I had concluded the series, before he reviewed it. Perhaps if he had done so, he would have been better prepared to judge correctly, whether I am so very heterodox upon agricultural matters. He commences his review by heading it 'Theories Examined and Explained,' and then says, 'such is the comprehensive heading of a series of articles, which Mr. LEVI BARTLETT, of Warren, N. H., is writing for the *Boston Journal of Agriculture*.' I gave no title to my communications, but the editor of the *Journal of Agriculture* headed it 'Theories Examined and Explained,' and is undoubtedly able to give sufficient reason for so doing, if he thinks proper to do so. This, then, is the 'whole head and front of my offence,' in reference to this 'comprehensive heading.'

"I have not time now to reply fully to the criticism of the *Farmer* on my articles; but from its tenor I think the writer entirely misjudges my views. He seems to suppose me strictly an advocate of the mineral theory, and opposed to the nitrogenous system; and that I am calling in question the correctness and utility of Mr. LAWES' expensive and valuable experiments. If so, he, or any one else so supposing, labors under a great mistake. My object in writing these—what the reviewer, in the height of his courtesy, terms—'gassy articles,' is not to build up or put down either of the above named theories. After many years of reading and observation, joined with unremitting labor on a farm, I do not find myself wedded to either system to the exclusion of the other; nor have I ever blindly written in favor of one side of the question, forgetting the merits of the other. In the course of my agricultural reading, I have come across a great many contradictory statements as to the results of different experiments, from the use of different manures, and also from the use of the same kind of manures on different soils. These diverse results, in connection with the contradictory opinions among scientific agricultural writers, are sorely puzzling to the great mass of working farmers, and serve rather to foster their prejudices than to throw light on their calling. Now if any correct explanations of these apparent discrepancies are ever to be made, it must be done by scientific investigations. In beginning the series alluded to, it was my great aim to reconcile, as far as possible, some of the 'vexed questions' of farming;—to explain them in such a manner as every farmer could understand them;—and thus to do away with much of the opposition against the application of science to agriculture. How far I may succeed in accomplishing said objects, I shall cheerfully leave to the good judgment of the readers of the *Journal*. The reviewer says I promised to bring forward facts and statements to support the mineral theory. Again he says, 'in number three of the series of letters, we have repeated assertions, but none of the promised experiments or facts.' Had he waited till the publication of my October number, he would have found some of the experiments reported; and for aught I know, Profs. DAUBENY, LINDLEY, ROGERS, HENSLow, &c., are entitled to full credit. Having a few more facts of the same kind on hand, I shall bring them forward, not, however, for the purpose of attempting to kill the ammonia theory. If the reviewer will turn to page 69 of the *Journal*, he will find that I am as strong an advocate of ammoniacal manures on some soils, and for some crops, as he is himself.

"The reviewer says, 'that neither LIEBIG nor Mr. B. appear to have read the pamphlets written by Mr. LAWES' himself but have taken up their able pens to refute what they have obtained only at second hand.' Again he says, 'as our article on plowing in green crops appears to be the source of Mr. B.'s information, why does he not attempt to refute the positions there maintained by us and not attack Mr. LAWES?' I did not attack Mr. LAWES, or undertake to refute the correctness of his experiments or statements, or even to express a doubt thereon. My sole object, in writing the articles in question, is, as I have said before, to attempt to reconcile some of the disputed points in agriculture.

The term "gassy" was applied to the articles of a well known class of agricultural writers who do nothing but write, in contradistinction to those who investigate the laws of nature in the field and laboratory, and not in any way to Mr. BARTLETT'S articles. We have usually read Mr. B.'s communications with great pleasure, and were not a little surprised and sorry that he had joined sides with the "mineral manure theory" advocates, as we most certainly thought was the case from the tenor of his "Theories Examined and Explained." We are, however, glad to find that we were mistaken, and that Mr. BARTLETT is "as strong an advocate of ammoniacal manures on some soils, and for some crops, as" ourselves.

Mr. B. has written four successive articles on this subject. The first was in reply to an article by R. M. COPELAND, of Boston, who thought mineral manures were not of so much consequence as ammoniacal ones; the other three articles have all been in reference to Mr. LAWES' experiments, or at least to a few results of his we gave in our article on "Plowing in Green Crops." That this article was the object of Mr. BARTLETT'S criticism, we had good reason to suppose from the fact that he quoted our summary statement of the results of these experiments, and adopted portions of our *language* in reference to their application to common farm practice. Besides, we stated some facts connected with the experiments, which have been published no where else; and these, too, Mr. B. mentions. Would it not have been more consistent with Mr. BARTLETT'S deservedly high reputation and scientific attainments, either to have "examined" Mr. LAWES' own account of his experiments, and his deductions from them, before he attempted to "explain" them? Or, if our article was the only source of Mr. B.'s knowledge of these experiments, (as we are forced to believe it was, otherwise he would not have *confined* himself to our account of them,) would it not have been more candid and honorable to have said so?

As the articles now stand, we hardly know what Mr. B. wishes his readers to believe respecting this "vexed question"—whether he coincides with our expressed opinions on the subject, or on what particular points he differs from us. Mr. B. says: "Had he waited till the publication of my October number, he would have found some of the experiments reported; and for ought I know, Profs. DAUBENY, LINDLEY, RODGERS, HENSLow, &c., are entitled to full credit." In the October number we find another article "examining and explaining" the few experiments of Mr. LAWES as given by us, and a few others giving, as he supposes, results very different; and engages earnestly in the effort of reconciliation. He first quotes from the late Prof. NORTON as follows:

"Prof. NORTON says, 'that during his stay in Edinburgh, samples from more than five hundred cargoes of guano were analysed in the laboratory of Prof. JOHNSTON, and were sold by his analysis, fluctuating in price as they indicated more or less ammonia. Had there been any mistake in this method of estimating value, experience would soon have detected it.'

"But notwithstanding the beneficial action of the sulphate and muriate of ammonia as used by Mr. LAWES, and what Prof. NORTON and others have said of its importance, there are numerous well authenticated facts on record that prove most clearly that the application of ammoniacal manures is not *always* attended with very marked beneficial effects, and there are also numerous cases where mineral or saline manures alone have produced extraordinary results, notwithstanding their failure on Mr. LAWES' wheat crop. Why such different effects should be produced by the same kinds of manure on different soils, is an important inquiry for the farmer; the only reasonable way of solving the question is by assuming as *facts*, the general principles laid down by LIEBIG, JOHNSTON, and other scientific writers on agriculture."

If we are to assume as *facts* the principles of LIEBIG and JOHNSTON, as applied by them to agriculture, there is no further necessity of field experiments, and BOUSSINGAULT and LAWES have spent their years, strength, and money, for that which profiteth naught; for the results of both of them are contrary to the principles of agriculture as laid down by LIEBIG and his followers.

But, to the promised experiments. The first is on *turneps*, on which phosphate of lime is found to do as much good as nitrogenous manures.

The second is by a friend of Prof. LINDLEY, near St. Albans, and is likewise on *turneps*. "The experiments were made, as all experiments should be, on an exhausted soil." Query: Who was the experimenter? Mr. LAWES' estate is four miles from St. Albans; his experiments on *turneps*, and in fact all his experiments, were made on an agriculturally exhausted soil; and he is a personal friend of Prof. LINDLEY. The chief result of these experiments is, that the *ashes* of a given quantity of barn-yard manure gave more *turneps* per acre than the same quantity of manure unburnt.

The next experiment is to show that the *ashes* of *wheat* are better manure than guano. The crop to which they were applied is not given.

Another experiment is from Prof. H. D. ROGERS' Geological Report of New Jersey, as follows: "Mr. WOOLEY manured a piece of land in the proportion of 200 loads of good stable manure to the acre, applying upon an adjacent tract of the same soil his marl, in the ratio of about 20 loads per acre. The crops, which were timothy and clover, were much the heaviest upon the section which had received the marl." There is evidently an error in the *figures*; but we presume the fact that the marl did most good, is well established.

What, we ask our intelligent readers, do these sundry experiments amount to, as the foundation of agricultural principles; or what do they show, as applied to the subject of discussion? They were tried, not on wheat, but on turneps, and timothy and clover. For turneps and clover we have always recommended soluble phosphate of lime as the best of all manures, and think ammonia unnecessary; that phosphate of lime, or any other mineral ingredient, does no good when applied to wheat on ordinary wheat soils; but ammonia, in whatever form applied, whether in barn-yard manure, guano, or salts of ammonia, is of great benefit. The experiments quoted by Mr. BARTLETT corroborate rather than disprove the truth of this proposition.

BRITISH AND AMERICAN AGRICULTURE.

The following conversation between two intelligent Western New York farmers, one of whom has recently returned from a visit to Europe, gives a good account of British farming as contrasted with American agriculture; with other matter that will be found interesting to the agricultural reader.

A. What most surprised me when first visiting the country in England, was the number and width of the hedges, some of them as crooked as a fiddler's elbow, and occupying a rod or two of land, and in many places thickly studded with trees, or, as they there call them, "hedge row timber," which do immense damage to the land. One farmer in Shropshire, when mentioning my surprise to him at this, said that many of the landlords objected to the tenants removing these crooked old hedges for fear of disturbing the game for which they afford an admirable shelter. He pointed me to a field of his, of six acres, around which there was a hedge and ditch at least a rod and a half wide, and in the hedge there was eighty-five large trees, which did great damage to the crops. The same farmer told me that the game did him at least \$500 damage a year on a farm of 250 acres. He complained most bitterly of Free Trade—said it was ruining the farmer, and that he was now losing money by farming, but that his landlord had promised to destroy the hares and rabbits, which do the principal damage, and to remove the hedge row timber; but nothing could give them such times as they had under protection, with wheat at an average of \$3 per bushel, and barley and other grains in proportion. The difference in the language, customs, and farming of even adjoining counties, perfectly astonished me. The farmer above alluded to said that when ELIOT BURRITT, the American "learned blacksmith," was lecturing in that neighborhood, he was one day speaking to his men of the many languages this working man had acquired, when a good old familiar servant, who often held forth as a primitive Methodist preacher, said that he knew two languages. His master, a little surprised, wished to know what they were; he replied, "Shropshire and Cheshire,"—two adjoining counties. Some twenty years ago, it is said that the judges at the assizes in the county of Lancashire were under the necessity of employing an interpreter before they could understand the language of the witnesses. The difference in farming operations is equally striking. In some counties you will see three, and sometimes four horses, one before the other, drawing a single plow, with a man to hold and a boy to drive—an acre being considered a good day's work. In another county, "double plows," or plows that take two furrows at once, are commonly used. If the land is heavy, or they wish to plow deep, five horses are attached to it *in length*. When plowing for barley in the spring, on light soil, four horses only are used, and they will plow from two to three acres a day. The plow will run itself, so that one man only is required; he does nothing else but attend to his four horses, generally commencing work at six o'clock in the morning, has a lunch and beer about ten, and leaves

off work for the day at three in the afternoon. In other parts, however, they abandon the tandem system altogether, and plow, harrow and cultivate as we do here, with two horses abreast. This is called the improved system of farming, and is rapidly being adopted all over the country.

B. Your account of English agriculture differs vastly from that given by many of our writers on the subject. I have always understood that England was the garden of the world—that the farmers were reading men and farmed on scientific principles.

A. Many parts of England and Scotland well deserve the name of gardens. The farmers are as you say, men of education and fortune, and farm in a style far exceeding any anticipations writers would lead us to indulge. The beauty of the landscape, large fields divided by straight and well trimmed hawthorn hedges with occasional shade trees, the luxuriance of the crops, perfection in the breeding of horses and all other domestic animals, the thorough system of under-draining, their beautifully arranged, substantial homesteads, with steam threshing and other machines, their well filled "stack-yards," and the neatness and system with which everything is done, command our involuntary admiration. Yet while this is so, the great mass of English farmers are by no means such an intelligent, industrious class of men as the farmers of this country. They expend much more capital and labor on the land than we do, and get much larger crops, yet I by no means think that they can raise a bushel of wheat, or a ton of clover, for a less sum than we can.

B. How is it that they obtain such large crops? The climate I have always understood is not as good as that of this country. It would seem that possessing our own farms, having no game or hedge row timber to trouble us, few taxes and no rent and tithes to pay, no restrictions as to our mode of farming, being in short lords of the soil, we could raise better crops than the English.

A. In regard to our climate being so much better for agricultural crops than that of England, I have considerable doubt. It is true our Genesee wheat is much superior to theirs, being heavier and plumper; yet their barley is much better than ours, weighing on an average 56 lbs. to the bushel, whereas ours here seldom goes over 45 lbs. Their growing season is much longer and cooler than ours, and the climate is most admirably adapted for the culture of roots, clover, and the far-famed English perennial grasses. It is the culture of these crops that places their agriculture so far ahead of ours.

B. You think then that our climate is better adapted* for the growth of wheat and corn, and theirs for the growth of clover and other green crops.

A. They do not raise such heavy crops of red clover as we do here. Many farmers told me they could not raise red clover once in four years, and substitute trefoil, white Dutch, and other varieties of clover and grasses in its stead, sowing the red clover once in eight years, and on the light barley soils once in twelve years. We can beat them altogether in growing clover. But it is the *Turnep crop* that lies at the foundation of England's agricultural glory. It is generally admitted that more nutritious matter can be obtained from an acre of land cultivated with Mangel Wurtzel, Ruta Baga, or common turneps, than from any other crop; and the climate of the British Isles is, perhaps, better adapted to their growth than that of any other country.

B. I do not clearly see how it is that the cultivation of turneps can make such a vast difference in the agriculture of the two countries as to make theirs so much superior to ours. If our climate and soil will grow better wheat and clover than theirs, we can easily dispense with turneps, for I consider clover the most valuable and the least exhaustive crop we grow. If I get a good crop of clover I make sure of good wheat after it.

A. Just so, you get a good crop of wheat after plowing in a growth of clover, because the clover has attracted fertilizing gases from the atmosphere and organized them by the aid of mineral matter from the soil. These when plowed in, or if the roots only are left, decay and furnish just the food in a fit state for assimilation, the wheat plant requires. This is eminently the case with clover; but the same thing is obtained by the English farmer, to a much greater extent, by means of his turnep crop, than we can with clover, and in this respect he has the decided advantage of us; that is to say, he can obtain more food per acre from his turnep crop than we can from any crop grown here, and can consequently keep more stock on his farm, and make more manure, thereby increasing the available food for plants, or, so to speak, have a greater amount of floating capital at the disposal of the plants.

B. You wish to make it out then that the superiority of British agriculture is not owing so much to science, or to their superior manner of cultivating the soil, but to the possession of a climate well suited to the production of large crops of turneps.

A. There are a great many scientific farmers there who are deserving of great credit for the number of experiments they try, and which serve to bring to view great principles in agricultural science; yet I think that the immediate cause of their growing larger crops of wheat and other grains than we do, is to be ascribed to the turnep crop and to the higher prices they even now command for meat, which enables them to purchase from us such large quantities of oil-cake to be consumed on their farms in its production:

B. It is no wonder that they have good crops if they grow such large quantities of turneps and grass, and buy oil-cake to eat with them, as well as large quantities of guano and other artificial manures. I guess our Western New York land would produce as well as theirs, if treated in this way.

A. I have not the least doubt that if we were to keep as much stock and manure as highly as the English farmers do, we should obtain, with our superior climate, for the elaboration of grain, at least fifty bushels of wheat to the acre, and one hundred bushels of *shelled corn* would be considered a poor crop. It is the general impression among farmers in England, that we raise much larger crops of wheat than they do. In fact, they have the strangest notions respecting us you can possibly imagine, and I believe the mass of the people who are certainly in love with our democratic institutions, think more of us than we are strictly entitled to. Everywhere I found myself an object of interest and was treated with marked respect and attention. I passed the greater part of my time in the country and thoroughly studied their most approved systems of farming, and by no means regret the time and money the journey cost me. I was most pleased with the farming of Norfolk. Some fifty years since it was nothing but a drifting sand. It is now the best farming county in Great Britain, producing more meat and grain per acre than any other.

But it is now getting late and I will have another talk on the subject some other night.

PEA CULTURE IN INDIANA.

WE have repeatedly recommended peas as one of the best crops that farmers can grow in rotation with wheat. They exhaust the soil little, if any, of those substances which wheat plants specially require; while the consumption of the pea and vines on the farm makes the manure of great value for wheat and corn. The great drawback to pea culture is the pea bug, though, as we recommended in the September number, if the peas are grown for feeding hogs, they may be all consumed before the bug does much injury. A gentleman in this neighborhood, at our recommendation, sowed four acres of the common white pea, and four acres of the Scotch grey pea, last spring. He had an excellent crop, the Scotch grey being somewhat the best. At harvest time there was not a bug visible. They were in excellent order when put in the barn. They have just been threshed, *and the bugs have eaten nearly all of them.*

The following interesting article from the *Indiana Farmer*, by I. D. G. NELSON, Wayne Co., Ind., shows that our western readers are wide awake and willing to try any experiments suggested to them. In the May number, page 142, we recommended late sowing as a preventive of the pea bug. The following experiments are to the point:

"Knowing something of the pea as a field crop when I was a boy, residing in the State of New York, where it is extensively grown, I determined some three or four years ago to make the experiment here. I found the seed scarce, and was obliged to purchase in small quantities of three different persons—sowed each variety, as I supposed, by itself, but found when ripening all *mixed*, some 'dead ripe,' others scarcely out of bloom. The yield, as you may well know, was a poor one, and the pea bug rendered worthless, or nearly so, those that I did raise. Not entirely discouraged, however, and not distinguishing among them the variety, as I thought, that is familiarly known in New York as the Canada field pea, I sent and obtained from J. P. Fogg & Co., Rochester, N. Y., the pure seed.

"Then the depredations of the pea bug, that is so fatal to its cultivation, nearly everywhere haunted me; but having read 'a long, long time ago,' in the *Genesee Farmer*, (a paper that I have always taken since it was established, some fifteen years or more ago,) that to prevent the depredations of the bug, peas should be sown after the 10th of June, I made the experiment; sowed one half 1st of April, the other half 10th of June. 'Book farming; eh!' exclaimed a friend to whom I explained

what I had been doing. 'It's all in your eye—the only reason why your peas will not be stung, will be because there will be no peas to sting.' Now for the result; those sown in April produced somewhat the largest crop, but were literally alive with bugs; those sown in June entirely free from them. Determining to test the matter further, and not having more seed than I wished to sow, I experimented further the following season, '51. I put all the peas together and sowed them promiscuously, bugs and all—a small portion the 1st of April, the remainder the 8th of June, side by side. The result about the same as the previous year—the April sown peas rather the greatest yield but full of bugs; those sown in June entirely free from them. Satisfied with the experiment, I sowed several acres this season, the 10th of June. I have just gathered them, and find no marks of the sting of the insect; the yield is much the largest I have ever had.

"My method of cultivation, is to prepare the ground well and sow about three bushels to the acre. I intend to experiment further next year, by sowing four bushels. I am inclined to think they will stand up firmer and yield more. I observe this season that uniformly where they stood thickest on the ground, they stood up better and looked finer. Yield from fifteen to twenty bushels—this year somewhat more. They should be gathered when fully ripe. Mow them with a scythe, in dry weather. Avoid rain if possible, and get them in the barn. If there is no mow room, thresh out immediately, clean up as soon as threshed, and give them the benefit of the barn floor a few days until they are perfectly dry, as they will heat if put up in bulk. I lost some in that way last season. The straw should be saved, as it is better for stock than wheat straw or poor hay.

"Next, as to the use and value of the crop, which is the important part of the subject. The uses are various; as food for stock it is highly valuable and profitable in the Eastern States, but whether it will prove so here or not I am not sufficiently posted up to speak definitely, but am inclined to think not, in our great corn districts. If I should raise them for that purpose, I should sow earlier, as the bug does not materially affect their value if fed immediately, and the yield is rather larger. They give hogs a fine start early in the fall immediately after the stubbles are exhausted, by fencing off and turning in, or cutting—feeding vines and all. A little later, and before corn is fit to feed, they may be boiled with pumpkins and potatoes—indeed, if properly managed, but little or no corn will be required to make fine pork. It is thus profitably managed elsewhere and I can see no reason why it may not be here. * * * * *

"The result of my experience, then, in the raising of peas amounts to this: Those that I raised last season were the first I sold. The product of the April sown peas were alive with bugs, and to prevent them from emigrating, fed them to my hogs. Those sown in June sold freely at two dollars per bushel, and I could not supply the demand; but what added peculiar interest to the matter was that two bushels were sold to the person who thought that raising peas free from bugs was 'all in your eye.'



GUANO ON POTATOES.—Last spring I planted four acres of potatoes on a two year old sod; the soil was a very light gravelly loam, well calculated to raise *sound* potatoes, but as it had been hard run, and never manured, it could not be expected to produce a large crop. I plowed the land deep and well, as early as the weather would permit, letting it lie till the time of planting—May 10th. It was then dragged, and on two acres 600 lbs. of Peruvian guano were sown broadcast. The land was then furrowed out in rows about three feet apart and potatoes planted in the rows, from twelve to fourteen inches between the sets. On the remaining two acres no guano, or manure of any kind, was applied, though treated exactly alike in every other respect.

As soon as the plants were up there was a decided difference visible. The guanoed ones having a richer, darker hue, which they maintained throughout the summer. In the fall, when the unguanoed potatoes were quite ripe and the vines dead, the guanoed ones were growing luxuriantly, the vines covering the whole space between the rows.

The potatoes were dug the last week in October, and accurately measured. On the unguanoed two acres, there was 238 bushels, and on the two acres guanoed, 410 bushels, making a difference in favor of the guano of 86 bu. per acre. All the potatoes are perfectly sound and good, but the guanoed ones are much the largest, with scarcely a small one among them. The guano cost in New York two and a half cents per pound; freight, breaking the lumps, sifting, and sowing it, would make its cost on the land three cents per pound, or \$9 per acre. The 86 extra bushels of potatoes will more than pay for the guano, &c., and leave a good profit from the investment.

As regards the best mode of application, I may state that in another field this year I had an acre of potatoes, part of which were guanoed, as on the other two acres, by sowing broadcast, planting the potatoes in hills. On part of the acre the guano was applied *in the hill*, placing the guano immediately over the potatoes, separating them with a little soil, otherwise it would injure the sett. The potatoes thus treated were *much better* than where the guano was sown broadcast. Four rows left unguanoed were not more than half as good as where guano was applied.

I consider guano a most powerful and valuable manure, though whether it will pay as well to apply it to wheat, corn, or other grain crops, as it has in this instance to potatoes, I cannot say. I have sown some on wheat this fall and can already see how far it extended, the difference being very perceptible. H. C. IVES.—Rochester, N. Y., 1852.

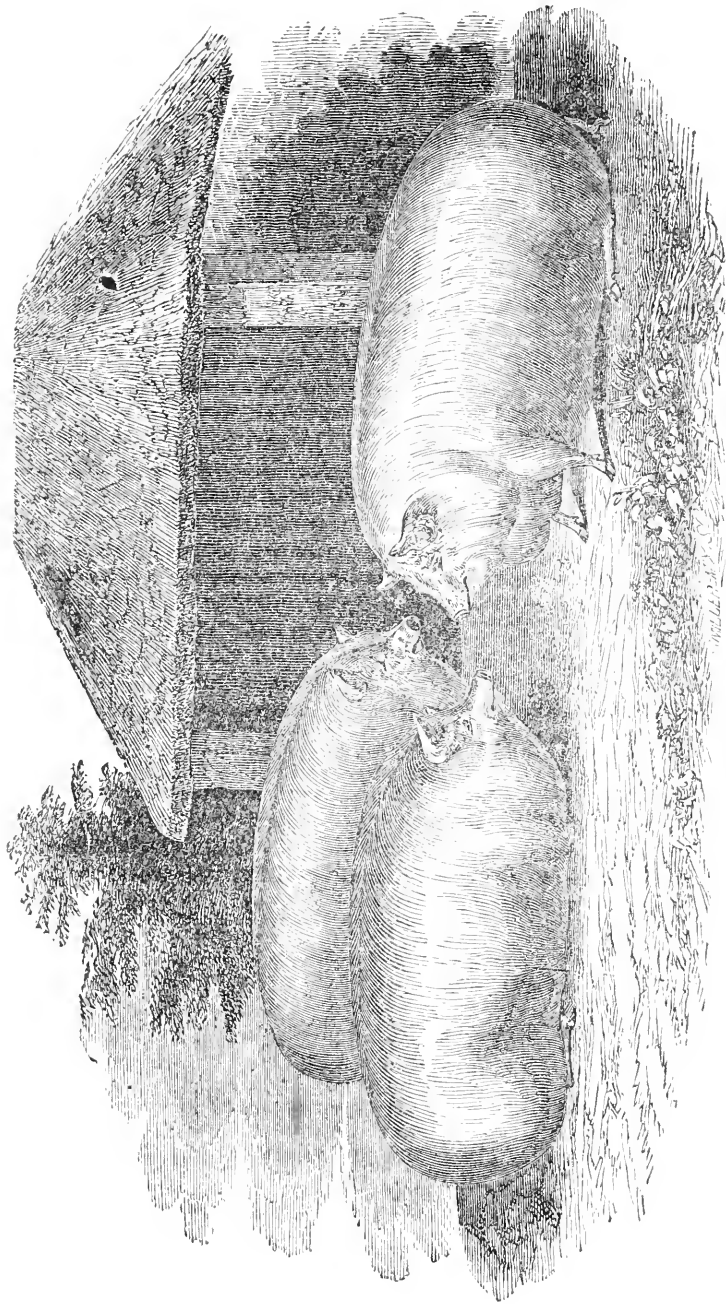

IMPROVED MIDDLESEX PIGS

BRED AND FED BY MR. WM. MILLS BARBER, OF LYBRIDGE, ENGLAND, FOR WHICH THE FIRST PRIZE OF \$50 WAS AWARDED, AND THE SILVER MEDAL, AT THE SMITHFIELD CATTLE SHOW.

MIDDLESEX HOGS.

Less, perhaps, is known in regard to the respective feeding qualities of different breeds of pigs, than of most other farm stock. We have had something approaching to a series of accurately conducted experiments upon the fattening qualities of different breeds of sheep, and also sundry, if not systematic, experiments on the fattening and milking properties of the principal breeds of cattle, such as the Short Horns, Devons, Ayrshires, Herefords, &c.; but we are not acquainted with one single experiment, that is comparative or satisfactory, in relation to the amount of meat produced, from a given quantity of food, by the various breeds of hogs. There are innumerable single experiments, but when we come to compare them we find that the animals were of different ages, fed on different food, and in short were differently treated in every respect. The results of course are very different. There would be "magic in the figures," could we trust them, and startling theories might be based thereon. There is always a certain degree of truth in the opinions of practical men, founded as they are on long experience, yet it would be interesting to every intelligent farmer to *know certainly* whether these opinions are true or not, and this can only be known by a series of experiments. It is supposed by many practical farmers that the small breeds of hogs will lay on more fat for the amount of food consumed than the large breeds. A carefully conducted experiment would settle the point. Who will make it? All the valuable English small breeds of hogs have been greatly improved by judicious crossing with the Chinese and Neapolitans. The Suffolk, Essex, Middlesex, and Berkshires, have all more or less Chinese and Neapolitan blood. All of them possess many valuable points, and are respectively best adapted for particular objects. For early maturity, rapidity of fattening, and small proportion of bone and offal, the Middlesex breed is, in our *opinion*, second to none.

The accompanying engraving represents three beautiful specimens of this breed, as exhibited at the Smithfield Club Cattle Show. "They were farrowed on the 18th of June, and were fed, from five weeks' old, on middlings, boiled potatoes, and peas, up to eleven weeks' old, when they had barley and pea-meal, and boiled potatoes, mixed with water. They consumed in thirteen weeks, twenty-eight bushels of meal and four bushels of potatoes. They were tried on milk, but did not thrive so well on it as on water. In consequence of their great propensity to fatten, they were blind with fat at sixteen weeks old, and when exhibited their eyes were buried two inches in fat, which came over their forehead and lay on the top of their noses full three inches.

The following is a statement of their weight and age while fattening :

Date.	Weeks old.	First.	Second.	Third.	Mean increase per week.
July	5	24 lbs.	24 lbs.	20 lbs.	
August	8	52 "	44 "	42 "	7 $\frac{1}{2}$ lbs.
September	11	80 "	72 "	64 "	8 $\frac{1}{4}$ "
<i>Idem</i>	14	104 "	96 "	88 "	8 "
October	17	152 "	144 "	132 "	15 $\frac{1}{2}$ "
November	20	200 "	192 "	192 "	17 $\frac{1}{3}$ "
<i>Idem</i>	23	232 "	224 "	224 "	10 $\frac{2}{3}$ "
December	6	232 "	224 "	224 "	
	24 and 3 days.				

This breed of pigs has been much improved by Mr. BARKER (the exhibitor) in the last seven years. They are of a pure white color, of great substance and propensity to fatten. They keep in excellent condition while stores on grass, turneps, offal from the barns or garden, and when put up to fat, in two or three weeks make excellent porkers. They are fine in the bone and head; small upright ears, which point a little forward. They are of a small size, have good litters, varying from seven to fourteen in number, being very fat while suckling, and thus making very good roasters.

Horticultural Department.

CONDUCTED BY P. BARRY.

OUR NATIVE TREES.

ALL at once there appears to have sprung up a very unusual appreciation of the beauty of our native trees. In half a dozen publications, issued at widely distant points, we find their eulogies set forth in the most glowing and enthusiastic terms. This is one of the most striking evidences of the growth of *real* taste that we have yet met with in all that has been said and written on horticultural subjects. As long as the riches and beauty of the sylvan treasures that nature has so unsparingly scattered over our own land, and around our own homes, remained unnoticed and unadmired, so long would it be indeed a most hopeless task to attempt to promote improvement in that department of horticulture which depends entirely upon taste. It is quite impossible that any one should be possessed of what is called taste, as relates to landscape or gardening, without having *felt* the grandeur and the beauty of our natural plantations and landscapes. What use would it be to talk of the artistic beauties of an English park, to a man who had lived his life time in the beautiful valley of the Genesee without seeing anything to admire in its charming landscape—its noble forests and broad meadows, blended with a skill that mocks man's puny efforts;—a man who had passed up and down the Hudson river a thousand times without feeling a single impression from its grand and picturesque scenery, the rock-work of which, compared to the artificial rock-work of the landscape gardener, is as a child's toy compared to a genuine gothic castle, or an outlet of a mill dam to the falls of Niagara. It is idle to describe the beauties of a *Deodar Cedar* to one who has not comprehended the grace and beauty of the Hemlock Spruce that grows by his door, or to talk of the lofty Pine of the Himalayas to one who has never looked upon our noble White Pine with admiration. The cultivation of rural taste, like the exercise of that greatest of virtues, charity, should "begin at home." Until we learn to love and admire the sweet and beautiful violet that blooms at our feet, it is folly to send to the antipodes for something more beautiful in imagination. We rejoice, therefore, to witness some healthy symptoms of an awakening sense of our native beauties, and to hear of people actually admiring and planting our native trees. We have never heard so many people speak of the beautiful autumn tints of our forests, as we have this past autumn; and this we are happy to note as another strong evidence of the growth of taste. The colors of the dying foliage have been indeed unusually brilliant and striking; but they have been so only to those who have some perceptions of the beautiful, and in whose hearts there is at least the *germ* of the love of nature.

This is a subject on which we would like to dwell, but we must await another opportunity. At present we will make a practical suggestion; for practical we must be, if nothing else.

There is many a good, honest farmer, whose dwelling stands bare as a light-house on an ocean rock, exposed to every wind that blows and every ray of sun that a merciless mid-summer day pours down on its devoted walls and windows. The very chickens can not find a shrub to shelter them, without making a journey of half a mile. Now that winter is upon us, and there are idle men sighing for something to do, and idle horses gnawing their stalls and growing unruly for lack of exercise and labor; go into the woods some fine, mild day, when there is snow enough on the ground to make comfortable sleighing, take up some fine young maples, elms, basswoods, tulip trees,

(whitewood,) put them on the sled and transport them to your homes, plant them along the roadsides, and here and there in the vicinity of your dwellings; and in a year or two you will find you have made a wonderful improvement in the comfort of your home and the appearance of your home landscape. Dig good large, wide, and deep holes for them. *First*, have some good loam from the fence corner or the woods, to put about the roots. Take them up with *all* the roots entire, prune the heads lightly, but don't "pollard" them; that is, cut off the heads entirely; for that destroys their natural characteristic forms for several years. *Shorten* the limbs only. If evergreens, such as Balsam Firs, Spruces, Hemlocks, Pines, and Cedars, can be had, don't fail to add a few of them.

PROCEEDINGS OF THE POMOLOGICAL CONGRESS.

THE Proceedings of the Pomological Congress held in Philadelphia on the 13th and 14th of September last, have made their appearance in a heavy pamphlet of 168 pages. We are indebted to Dr. W. D. BRINCKLE, of Philadelphia, for an early copy. This volume surpasses by far any of its predecessors, not only in the quantity, but in the value of its contents; and this value is greatly enhanced by its prompt publication. It opens with the excellent address of the President, Dr. BRINCKLE; then follow the lists of delegates, showing thirteen States to be represented; then the officers elected for the ensuing year; address of the Hon. M. P. WILDER, the newly elected President, on taking the chair; proceedings in regard to the late A. J. DOWNING; subjects reported by the business committee for the action of the meeting; Constitution and By-Laws of the Pomological Society; discussions on fruits; committees; lists of contributors of fruits; catalogue of varieties adopted, recommended, and rejected by the Society; reports of State committees; and lastly, the eulogium pronounced by Col. WILDER. The Reports of the State Fruit Committees contain many valuable and interesting facts and statements, which we shall hereafter cull, as leisure permits. We find reports from Maine, Vermont, New York, New Jersey, Pennsylvania, Delaware, District of Columbia, Virginia, South Carolina, Kentucky, Michigan, and Illinois.

The discussions on fruits we had intended to condense, and give a sketch of their substance; but not finding leisure to do so, we shall at present extract entire, as we find them in the report, the discussions on three popular varieties of pears, the *Dearborn's Seedling*, *Duchesse d'Orleans*, and *Dojenne d'Ete*:

"Hon. SAMUEL WALKER, Massachusetts. I will suggest the propriety of cancelling from that list the *Dearborn's Seedling*. I am ready to admit that when you have a fine large specimen, well ripened, it has very few equals, and I was almost about to say, has no superiors. I have found it, however, to be a very small pear as regards the average crop, and not well fitted for the market. My next reason is that it is a very poor grower, and in order to get fine specimens of it, the grafts must be put into large stocks, say from twelve to twenty years old; then it must be very well cultivated. I make these remarks to ascertain the experience of other gentlemen in regard to this pear.

"Mr. S. B. PARSONS, Flushing, Long Island. I am sorry the *Dearborn's Seedling* proves so bad near Boston. With us, on Long Island, it is the best pear of the season, although not very large.

"Mr. HANCOCK, Burlington, New Jersey. It has done very well with me for the last six years; but I find one objection to it, and that is, if you have a large crop, the pears are inferior. For my own section of the country, I hope it will not be stricken out. I speak of New Jersey.

"Col. HODGE, of New York. I have known this pear six or eight years, and have made up my mind to strike it out from my own collection for two years past, and for myself move it be stricken from the list.

"Mr. HAYES, of New Jersey. I have found, from actual experience, that it has been more profitable to raise it for the market, this season, than any other early pear, and I am very much opposed to striking out pears and other fruit until they have been thoroughly tried. I trust it will not be stricken out.

"Mr. ESHLEMAN, of Pennsylvania. With me the *Dearborn's Seedling* in the interior of this State is prolific to a fault, and small, but as good as anything we have of its season.

"HON. B. V. FRENCH, Massachusetts. When that pear first made its appearance in our horticultural rooms I thought it unworthy, but I believe I shall now do something with it. However, I don't think much of any early pear; but notwithstanding, though I voted against its admission, I shall let it remain in.

"MR. ERNST, from Ohio, thought little of the pear, and said that for worse pears, in his estimation, he had obtained a better price.

"MR. BARRY, of New York. I am quite surprised to hear that the Honorable gentleman from Massachusetts recommends that *Dearborn's Seedling* should be stricken out, for in New York it is a good pear.

"MR. HOVEY, of Massachusetts. I, for one, am opposed to going back, and taking out anything we have already recommended; and I trust we shall not, during this Convention, adopt any one fruit for general cultivation in regard to which there is the slightest doubt. I always am opposed to retrograde motion. The *Dearborn's Seedling* is one of the best small pears, and I feel it my duty to say a word in favor of it. It is a full medium-sized pear, and I have seen specimens from Western New York and Massachusetts, from Utica and Rochester, as large as the average *Seckels* that we see. We had better let it remain just where it is. It ripens on the tree, and does not rot at the core; I therefore trust it will not be removed from this list.

"COL. HODGE, of New York. I am glad to hear good reports of it from different parts of the country, but with me it has proved quite indifferent, and I was glad to hear the Hon. Mr. WALKER make the remarks he did in regard to it. However, seeing so much opposition, I withdraw the motion.

"MR. HOVEY, of Massachusetts. I move that the *Duchesse d'Orleans* be added to the list for general cultivation. I know it is a good pear, and will do well everywhere. The pear is well known around Boston, and came from France with a high reputation. It is large in size and delicious in flavor. It is precisely the same as the *Bourre St. Nicholas*, and Mr. RIVERS says he considers it fully equal in flavor to the *Bergamot*.

"MR. SAUL, of New York. This pear has proved very good in our locality; but we hardly know enough of it to recommend that it should be brought into general cultivation.

"MR. WALKER, of Massachusetts. I have had the *Duchesse d'Orleans* in my collection for three or four years, and think it should be annexed to the list of pears that promise well; but I have no doubt it will find its way upon the list for general cultivation when better known.

"THE PRESIDENT, Hon. M. P. WILDER, of Massachusetts. On the quince it is not a good grower with me; but on the pear it is, and produces a fine and handsome fruit. It has not been with me a great bearer, although I have a pretty fair crop this year, and perhaps enough for the tree. I should judge my experience does not agree with that of Mr. MANNING, who has called it a great bearer. But as regards the quality and beauty of the fruit, I think there can be no doubt.

"MR. BARRY, of New York. We have tested it on the quince and pear, and its quality is very fine; and I believe it is going to be one of the finest pears for cultivation. I think, however, it would not be doing the pear justice at the present time to put it on the list for general cultivation, as it is not sufficiently well known for many to vote understandingly in regard to it.

"It was agreed that the *Duchesse d'Orleans* remain on the list as promising well.

"MR. SAUL. I move that the *Brandyquaine* and *Chancellor* stand on the list as giving promise of being worthy.

"This motion was agreed to.

"MR. HARVEY. I move that the *Doyenne d'Ete* be placed on the list for general cultivation.

"MR. ERNST, of Ohio. It has proved to be an exceedingly beautiful fruit, and I can cheerfully vote for it as far as my experience goes.

"MR. S. B. PARSONS. We consider it in Flushing the first good pear.

"MR. SAUL. It has proved to be one of the very best small pears.

"THE PRESIDENT. I enter into the views of those who have already spoken, but think it will be better on the pear than on the quince.

"MR. HANCOCK, of New Jersey. I think it is better on the pear than on the quince.

"MR. HOVEY. It don't make that vigorous tree on the quince that it does on the pear.

"MR. WALKER, of Massachusetts. From such a mass of evidence in favor of this pear, I would hardly venture to say that I differ; but yet I can not be silent. It does not strike me as being so delicious as represented, and on the quince stock it is decidedly a poor grower. It drops its fruit, and it bears rather the reverse character to a first rate grower with me. On its own stock it does better and the fruit is larger; but I think the gentlemen overrate the pear. If my specimens are a fair sample of the fruit, I venture to say that in two or three years hence they will change their views of the matter. I hope the chair will give his opinion in full.

"HON. M. P. WILDER, of Massachusetts. I have already expressed an opinion, that on the pear stock it is a desirable variety, and the remarks that have been made in regard to it on the quince, correspond with my own experience. It should be picked before the season of its ripening. It comes at a period when there is nothing so beautiful. We have the *Madeleine* at nearly the same time; but I still think it a desirable variety in rich soils.

"MR. BARRY, of New York. The impression we have got is that it is decidedly the best early pear. At Utica, the other evening, there was a small Convention of fruit growers, and they decided, unanimously, that this was the best early pear. It ripens with us before the *Madeleine*, and is decidedly better. It is a splendid grower on the quince, and so it is on the pear, and when it comes off the tree it is full of juice and luscious.

"Mr. Nourse, of Maine. We have had but little opportunity to test in Maine; but it is there regarded as the best pear, and is considered better than the *Madeleine*. It ripens about the same time. "It was decided that the *Doyenne d'Ete* is worthy of general cultivation."

The following is a catalogue of all the varieties recommended by the Society at its several sessions, for general cultivation and trial:

FRUITS WORTHY OF GENERAL CULTIVATION.

APPLES.

American Summer Pearmain,
Baldwin,
Bullock's Pippin,
Danvers Winter Sweet,
Early Harvest,
Early Strawberry,
Fall Pippin,
Fameuse,
Gravenstein,
Hubbardston Nonsuch,
Large Yellow Bough,
Lady Apple,
Porter,
Red Astrachan,
Rhode Island Greening,
Roxbury Russet,
Summer Rose,
Swaar,
Vandervere,
White Seek-no-Further,
Wine Apple, or Hays,
Winesap,
And for particular localities.
Canada Red,
Esopus Spitzenburg,
Newtown Pippin,
Northern Spy,
Yellow Belle Fleur.

PEARS

Ananas d'Ete,
Andrews,
Belle Luerative or Fondante d'
Autonne,
Beurre d'Anjou,
Beurre d'Arenberg,
Beurre Bose,
Bloodgood,
Buffum,
Dearborn's Seedling,
Doyenne d'Ete,
Flemish Beauty,
Fulton,
Golden Beurre of Bilboa,
Louise Bonne de Jersey,
Madeleine,
Paradise d'Autonne,
Rostiezer,
Seckel,

Tyson,
Urbaniste,
Uvedale's St. Germain, for baking
Vicar of Winkfield,
Williams' Boncretien or Bartlett,
Winter Nelis.

And for particular localities.

Grey Doyenne,
White Doyenne.

APRICOTS.

Breda,
Large Early,
Moorpark.

NECTARINES.

Downton,
Early Violet,
Elruge.

PEACHES.

Bergen's Yellow,
Cooledge's Favorite,
Crawford's Late,
Early York, *serrated*,
Early York, large,
George the IVth,
Grosse Mignonne,
Morris White,
Old Mixon Free.

And for particular localities.

Heath Cling.

PLUMS.

Bleecker's Gage,
Coe's Golden Drop,
Frost Gage,
Green Gage,
Jefferson,
Lawrence's Favorite,
Purple Gage,
Purple Favorite,
Washington.
And for particular localities.
Imperial Gage.

CHERRIES.

Belle Magnifique,
Black Eagle,
Black Tartarian,

Downer's Late,
Downton,
Elton,
Early Richmond, for cooking
Graffion or Bigarreau,
Knight's Early Black,
May Duke.

GRAPES.

Under Glass.

Black Hamburg,
Black Prince,
Black Frontignan,
Chasselas de Fontainebleau,
Grizzly Frontignan,
White Frontignan,
White Muscat of Alexandria.

Open Culture.

Catawba,
Isabella.

RASPBERRIES.

Fastoff,
Fraconia,
Red Antwerp,
Yellow Antwerp.

STRAWBERRIES.

Boston Pine,
Hovey's Seedling,
Jemey's Seedling,
Large Early Scarlet.

CURRANTS.

Black Naples,
May's Victoria,
Red Dutch,
White Dutch,
White Grape.

GOOSEBERRIES.

Crown Bob,
Early Sulphur,
Green Gage,
Green Walnut,
Houghton's Seedling,
Iron-monger,
Laurel,
Red Champagne,
Warrington,
Woodward's White Smith.

NEW VARIETIES WHICH PROMISE WELL.

APPLES.

Autumn Bough,
Hawley,
Melon,
Mother,

Nothern Spy,
Smoke-house.

PEARS.

Brandywine,

Brand's St. Germain,
Beurre Giffard,
Chancellor,
Doyenne Boussoek,
Doyenne Goubault,

Duchesse d'Orleans,
 Duchesse de Berri,
 Diller,
 Jalousie de Fontenay Vendee,
 Kirtland,
 Limon,
 Manning's Elizabeth,
 Nouveau Poiteau,
 Onondaga,
 Ott,
 Pratt,

Paradise d'Automne,
 St. Michel Archange,
 Stevens' Genesee,
 Striped Madeleine,
 Van Assene.

PLUMS.

McLaughlin,
 Prince's Yellow Gage,
 Rivers' Favorite,
 St. Martin's Quetche.

CHERRIES.

Bigarreau Monstreuse de Bavay,
 Earle Purple Guigne,
 Reine Hortense.

GRAPES.

Diana.

RASPBERRIES.

Knevett's Giant.

STRAWBERRIES.

Burr's New Pine.

NEW FOREIGN PEARS.

BY B. DESPORTES, OF ANGERS, FRANCE.

BARON DE MELLO. (*Adele de St. Ceras.*) Fig 1.—I find this variety in the collection of Mr. ANDRE LE ROY, but do not know its origin. It is disseminated under the names

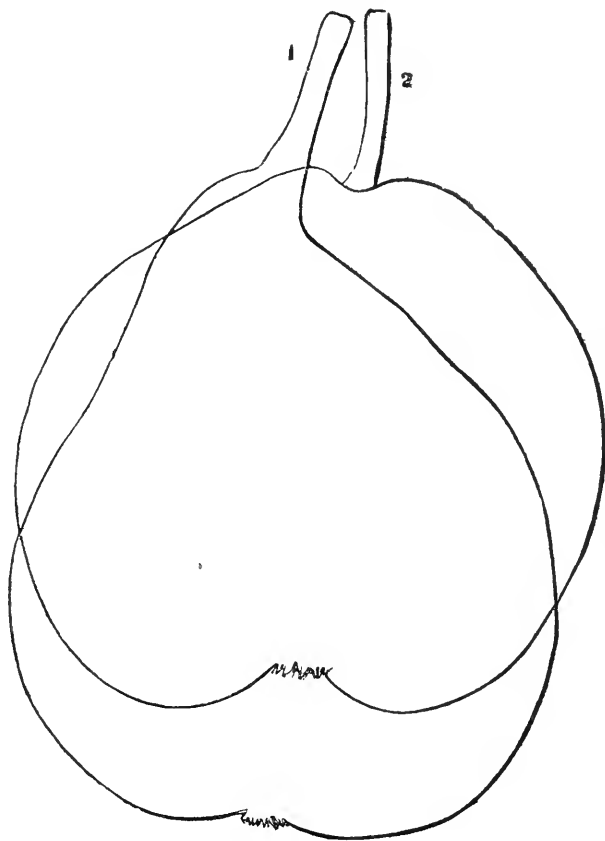

of *Baron de Mello*, and *Adele de St. Ceras*; but I think the first ought to be preserved, and we shall adopt that name. *Fruit* medium to large size.—*Skin* clear russet. *Eye* shallow; diversions of the calyx short. *Flesh* yellowish white, half melting, very juicy, sugary, with a slight acidity and a very agreeable flavor. It is a good fruit, ripening in October. The *tree* is of medium vigor, very much branched. *Shoots* long, and of a violet red color, covered with brown dots. *Buds* large, conical.—*Leaves* flat, lanceolate, and almost entire. Remarkably productive.

We will add that this variety has fruited in several collections in this country. We received it from France as *Adele de St. Ceras*, and from RIVERS as *Baron de Mello*. we presume the latter will be the generally adopted name. Specimens from our own trees,

that were picked for the exhibitions, ripened and were eaten on the 28th of September. Our notes made at that time describe it as "large, greenish russet, becoming a rich cinnamon. *Stalk* obliquely inserted under a fleshy knob. *Flesh* greenish white, juicy, melting, with a sprightly, agreeable flavor. Evidently related to the *Brown Beurre*." We had specimens sent us by Col. WILDER of Boston,

which we cut on the 22d of October. similar in character to our own, but with a less degree of acidity. RIVERS describes it as "a very good, melting pear, equal to *Brown Beurree*, and quite hardy. Succeeds well on the quince, and forms a handsome pyramid."

BEZY GOUBAULT. Fig. 2.—This variety was originated by GOUBAULT, at Angers, some ten years ago. The tree is of remarkable vigor, somewhat thorny, resembling in its form and habit the *Glout Morceau*. The branches are irregular, with a dark gray bark. Joints short. Buds very large and prominent. The leaves are short, lightly toothed, and of a dark blackish green. Fruit roundish, large. The stalk is inserted in a cavity formed by two small mamelonous. The calyx is small, in a large and deep cavity. Skin yellow, marked with brown points or dots, and a large patch of russet around the stem and eye. Flesh yellow, fine, melting. Juice abundant, with considerable acidity. Ripens in October and November. Very productive.

We are inclined to think, from Mr. DESPORTES' description of this variety, that it will be a better kitchen than table pear.—Ed.

FRUITS FROM NEW HAMPSHIRE.—Finding that you take much pleasure in testing and discussing the qualities of the different varieties of fruits, as they become introduced to the public, I send you some of the native varieties found in my immediate vicinity.

No. 1 is a native fall apple, which we call the *Woodward*; Mr. WOODWARD originally owning the land on which the tree stands. It is now owned by D. BOSWORTH. The tree is a good bearer in even years, and bears moderately in the intermediate years. The tree has never been cultivated, and stands in an old pasture which inclines moderately to the west. The soil is a sandy loam, rather moist.

No. 2 is a winter variety, which originated on the land originally owned by J. TICKNOR, and called the *Hebbard Russet*; J. HEBBARD now being the proprietor. The soil is very much like the first, with a westerly inclination. The original tree is probably sixty or more years old; and although it has never been cultivated, and stands so as to take the full northwest blast, it is still thrifty, and bears large crops. I find by cultivation that it is perfectly hardy in this vicinity, and bears well; the fruit almost invariably fair. The young trees in the nursery are inclined to throw out lateral branches; and for this reason they may be set nearer together, and they produce straight, handsome trees.

The pear is what we call the *Tilden*, Mr. ASA TILDEN owning the land on which it grows. It is rather a shy bearer when young; but I think that this will be materially changed when the young grafted trees come into bearing, as nearly all of the trees now of bearing size were raised from suckers from the old tree. The original tree and all the young trees when they come into bearing, produce large crops and bear every year. The trees are good growers and hardy. I can not send you a fair sample of this pear, as it is too late for them. The one I send you is about half the usual size.

The apples are about the medium size as they generally grow in this vicinity. Those I send were picked from the original trees. R. S. HOWE.—*Lebanon, N. H.*

The *Tilden* pear is a handsome medium-sized fruit, obovate in form, inclining to oval. Skin smooth, yellow, tinted with red next the sun, and thickly sprinkled with reddish dots. Flesh juicy, melting, and sweet; pleasant, but not high flavored.

The *Woodard* apple is a very beautiful fruit, resembling the *Summer Rose*. Pale yellow or cream colored ground, with broken stripes and dashes of light red. Flesh soft, tender, and fine grained. The flavor was impaired by carriage when in a ripe state.

ACKNOWLEDGEMENTS.—We are indebted to Hon. MARSHALL P. WILDER, of Boston, for superb specimens of the following pears: *Beurre d'Anjou*, *Triumph de Jodoigne*, *Urbaniste*, *Beurre Superfin*, *Beurre Langelier*, *Baron de Mello*, *Nouveau Poiteau*, *Van Mons'* 1825, and *Collins*, (a native sort.)

— To Dr. PENNINGTON, of Illinois, for very large and beautiful specimens of the following apples: *Smoke-house*, *Tulphoeken*, *Willow Twig*, *White Belle Fleur*, *Winesap*, *Rambo*, *Smith's Cider*, *Yellow Belle Fleur*, *Belmont*, *Rawles Janet*, *Vandervere*, and *Dominie*.

Editor's Table.

LADIES' DEPARTMENT.—Our Index, &c., so occupies our room this month, that we are compelled to omit our Ladies' Department. The following is one of the many inquiries we have received in relation to Flower Seeds:

"My wife wished to inquire if your offer of flower seeds extends to another spring, as she is anxious to try the effect of introducing the flower culture among the Indian women, with a hope that, like music, it may exert a refining, humanizing influence over their tastes and habits, and thus aid us in our missionary labor." A. S.—*Versailles, N. Y.*

We are not proof against such appeals, and shall supply our female friends who may apply during the winter, with seeds in season for spring planting.

IMPERSONALITY OF THE PRESS.—The Boston *Journal of Agriculture* for November, contains a vehement personal attack on the proprietor of this paper for a criticism of a series of articles written by Mr. LEVI BARTLETT, and published in the *Journal* under the heading, "Theories Examined and Explained." Had the author of said attack thought of the impersonality of the press, and the comity of journalists, he would have learnt the name of the offender, before he presumed to call names and use harsh epithets. Having failed to do this, he has wantonly assailed one who neither wrote nor saw the comments on Mr. BARTLETT'S articles until they appeared in the *Genesee Farmer*. They were written by Mr. JOSEPH HARRIS, who was with Mr. LAWES and Dr. GILBERT when the experiments and researches were made upon which the discussion arose.

It is due to Mr. H. to say, that he has contributed much to the editorial pages of the *Farmer* during the year, in the volume now brought to a close; and to add that his name will hereafter appear as one of the responsible editors of this journal. The proprietor acts upon the principle that it is better to pay liberally for original matter of real value than to publish that of an inferior quality, though paid for inserting it. So long as the farmers, gardeners, and fruit-growers of this continent sustain the *Genesee Farmer* as they now do, it shall faithfully represent their paramount interests, regardless of all mere personal considerations.

CORNSTALK CUTTERS AT THE STATE FAIR.—JOSEPH G. GILBERT, 216 Pearl street, New York, complains that in our account of the late State Fair at Utica, we noticed "TAYLOR, THOMAS & Co.," and "HUBBS Patent" Straw and Corn Cutters, but did not men-

tion "URMY'S Patent Corn Stalk Cutter and Grinder," which also was upon the ground.

We did not pretend to any such a task as giving an account of all the valuable implements exhibited, but merely intended to mention such as were recent inventions or improvements on those commonly in use, as came under our observation in the short time allowed us for their examination. We regret that we did not see URMY'S Cutter and Crusher. If, as the published testimonials say, it will cut and crush 75 to 100 bushels of stalks, or one ton of hay and straw, per hour, worked by hand, and that in consequence of the crushing, the cattle will eat up all the stalks without waste, it is a valuable cutter. Price \$35.

YOUNMAN'S CHART OF CHEMISTRY AND CLASS BOOK OF CHEMISTRY.—MR. EDWARD L. YOUNMAN has rendered the public a great service in getting up a Chart of Chemistry, for the use of schools and academies, which, with his Class Book, will render the study of the principles of the science at once easy and interesting. The importance of a knowledge of chemistry to the farmer, gardener, mechanic, manufacturer, and professional man, is now universally admitted; and the only debatable point is, the best plan of teaching the science. For the million, Mr. YOUNMAN'S Chart is *the thing*; and every school in the United States should have one for the benefit of its pupils.

NEW AGRICULTURAL PAPERS.—MESSRS. A. B. ALLEN & Co., of New York, have commenced the publication of a large, well filled weekly sheet called *The Agricultor*; and Mr. LUTHER TUCKER, of Albany, N. Y., has started a somewhat similar journal, folded to have sixteen pages, under the title of *The Country Gentleman*. The proprietors of these papers are well known to reading farmers, and each offers his hebdomadal at \$2.00 per annum.

Our friends ordering the *Farmer* will be particular in giving the name of the Post Office, County and State; also, in writing names plain, as by this much perplexity may be avoided to ourselves and subscribers.

TERMS—FIFTY CENTS a year for single copies; *five copies* for \$2, being *forty cents each*; and *eight copies* for \$3, being *thirty-seven cents each*, and any greater number at the same rate.

AGRICULTURE IN MAINE.—A handsome, well arranged volume, entitled, "Transactions of the York County Agricultural Society for the years 1850 and '51"—for which we are indebted to the Secretary, S. L. GOODALE, Esq., of Saco—shows that our eastern friends are no less active in promoting agricultural improvement than those who consider themselves favored with a more genial climate. We have perused with pleasure an admirable and awakening address, by the Rev. W. A. DREW, of Augusta, delivered before the Society in 1850; another, by Dr. HOLMES, of Winthrop, in 1851; also a valuable paper on agricultural education, besides many interesting reports.

A county with a Society such as that of York appears to be, can not but be in a most prosperous condition.

A FINE FARM FOR ORCHARDING.—GEO. J. WHITNEY, Esq., of Rochester, offers to sell, or rent for a term of years, his beautiful farm on the Rochester and Charlotte Plank Road, in the neighborhood of Mr. DONNELLAN's and Messrs. RYAN & Co.'s gardens and nurseries. It contains 150 acres of land, all in fine condition, well fenced, &c., with large orchard of the best fruit just coming into bearing. It is well watered and contains every requisite for orcharding. To any person desiring to embark in this business, a more eligible location, or tract of land cannot be found. We thus notice it because we have heard of late several inquiries on the subject.

MANY articles, some of them in type, we are compelled to omit; among them several answers to inquiries, which will appear in our next.

ADVERTISEMENTS, to secure insertion in the *Farm-er*, must be received as early as the 10th of the previous month, and be of such a character as to be of interest to farmers. We publish no other. Terms—\$2.00 for every hundred words, each insertion, *paid in advance*.

Inquiries and Answers.

WATERING SHEEP, &c.—Many times have I been thinking on some doubtful point connected with agriculture, and on the "tip toe" of writing to you for light on the subject, when the very next number comes with the answer to some other inquirer. But there are several questions in my mind which I have not seen treated upon:

1st. Concerning sheep watering—Some farmers let their sheep go all the season without water. Is this right or wrong? Have any experiments been tried on this point? What is the effect of not watering?

2d. Can as much butter be obtained from sweet milk as from the same quantity of sour? Experiments and facts wanted.

3d. Are cisterns ever used on dry farms? If so, with what success?—the best mode of constructing them, &c. &c. R. P. ROBINSON.—*Cliftonango, N. Y., 1852.*

1st. When sheep are fed on green food they will do very well without water; but if their food is dry, a regular supply of water is absolutely necessary for the health of the animal. In winter many farmers we know do not give their sheep any water, and the poor things have to supply themselves by eating snow; but when water is accessible they manifest a decided preference for it and drink regularly. In some experiments on South Down sheep, we found that when fed on clover hay alone, in the summer months, each sheep eat about three pounds of clover hay and drank six pounds of water per day. Thinking they drank more than was good for them, we confined them to a less quantity for a week; they did not eat so much food, and *lost weight* during that week.

2d. There is considerable difference of opinion on this point. Some say the butter is sweeter and altogether better when the milk is churned while sweet, than if soured. It is, however, exceedingly difficult to get the butter from sweet milk; and, in fact, however sweet the milk may be when put into the churn, it always turns sour in churning or the butter will not come. A better quality, though possibly not so large a quantity, of butter can be obtained from the cream alone, than when the whole cream and milk are churned together; there is less cheesy matter (casein) in the butter, and it is better for packing and preservation. There is the same amount of butter in the sour milk as there is in the sweet; the sugar, and not the butter, being converted into lactic acid; and as butter is obtained much easier from sour than from sweet milk, it is probable that the sour milk will yield the most butter.

3d. We know of no satisfactory experiments on the point.

HORTICULTURAL.

(DAN'L F. H.) The wild crab may be used for a stock. We should prefer grafting it near the ground, unless very large, in order to avoid the difficulty of the scion over or out growing the stock.

A Subscriber wishes to know where he can obtain Cranberry seed, and the quantity necessary for an acre, and also the manner of sowing, culture, &c., &c.

Willow cuttings can be procured at the nurseries. You will find a market in any large town, only let it be known that you have such an article for sale.

(V. T., Kingsville.) We would advise you to plant your Osage Orange next spring. We prefer

yearling plants for a hedge, to those which have stood two years in the seed bed. You have to cut them back to near the surface of the ground, at any rate, and the young plants are less checked, and throw out an abundance of branches with more rapidity than the two year olds.

(J. M. WARD.) PLANT BUGS.—The bug so injurious to your potatoes and flowers, is probably the common squash bug; and the means you have adopted to destroy them or prevent their ravages, are the only ones we know, unless that of calling in the aid of poultry.

THE BLACKBERRY.—This is cultivated in the same way as the Raspberry. Give them a good, light, rich, loamy soil.

THE HORTICULTURIST.—Address JAMES VICK, JR., one of the editors of the *Farmer*, who has recently purchased it and will publish it after the 1st of January, as you will see by prospectus.

Emery & Co.'s Improved Horse Powers, Thrashers, and Separators.

THE undersigned have been appointed sole agents for the sale of Emery's new Patent Improved Horse-Powers, Thrashers, and Separators, in the city of New York. The State Agricultural Warehouse is the only depot where this superior Power can be had.

LONGETT & GRIFFING,
7-ft. State Ag. Warehouse, 25 Cliff st., New York.

Superphosphate of Lime.

THE genuine article, manufactured by C. Duburg, in bags of 150 lbs. each. The subscribers have made a contract for a large quantity. We are now prepared to supply any quantity that may be ordered. Farmers and gardeners would do well to call on us before purchasing elsewhere, as we are now able to sell for a less price than heretofore offered. Every bag is branded "C. Duburg, Extra, No. 1."

LONGETT & GRIFFING,
State Agricultural Warehouse, No. 25 Cliff Street, New York. [11-1f]

Pure Java Fowls,

WARRANTED PURE, from imported stock direct from Java. This breed is not excelled by any raised in the United States for laying or hatching. Weight from 15 to 20 lbs. per pair. Their color is a shiny black.

Also, some very fine Black Polands, which are better known than the Javas.

Price—Javas, \$5.00 per pair; Polands, \$5.00 per pair. Address J. W. PLATT, Rhinebeck, N. Y. [12-*1]

ANDRE LEROY, Nurseryman, at Angers, France,

HONORARY and Corresponding Member of the principal Horticultural Societies of the United States and Europe, begs leave to inform his friends and all the Nurserymen of the Union in general, that he has made large preparations and has now on hand, a considerable stock of the finest Evergreen Seedlings, Roses, Fruits, and Ornamental Trees, &c. &c., most suitable for the American market. The experiments of several years, of putting up large orders for the United States, enables him to flatter himself that he has now all the necessary knowledge to give full satisfaction, and to insure the delivery, in good order, of all the Trees, &c., ordered.

He also begs to inform all Nurserymen who have not already received the supplement for 1852, to his Catalogue for 1851—that it can be obtained free of any charge at his Agent's office, M. Ed. Bossange, 138 Pearl St., New York, who will also attend to forwarding all orders sent to him, and to pass through the Custom House; and re-ship all goods ordered without any delay and with the greatest care.

Address M. ANDRE LEROY, Angers, France, care of
ED. BOSSANGE,
188 Pearl Street, New York.

[11-21]

188 Pearl Street, New York.

Potatoes—The White Mercer.

500 BARRELS of the White Mercer (seedling) Potatoes are now offered for sale by the subscriber. This remarkable white potato is of almost unparalleled productiveness—of beautiful shape—its proportion much like the long pink-eye, being a little more fattened.

This potato was obtained by the subscriber from the seed of the common Mercer, nine or ten years since. It received the first premium from the N. Y. State Agricultural Society, and a Diploma was awarded for the same by the Monroe Co. Agricultural Society. Since this period the White Mercer has attained, in Irondequoit, increased popularity with farmers and gardeners—to so great an extent that from 800 to 900 acres were planted in that town, the past season, the product of which has been astonishingly abundant—yielding from 150 to 400 bu. per acre, as I have been creditably informed. The yield of my own crop, planted mostly among fruit trees, gave 200 bu. of fine potatoes per acre. Those who have hitherto had but a scanty supply of the article, on account of the rot, or from any other cause, may, by obtaining a barrel or two of White Mercers grow them in great abundance.

The White Mercer is very white outside and in, mealy, of good flavor, and longer keeping than any other potato with which I am acquainted. It is a late grower, requiring early planting, and is less subject to rot than any other potato known in these parts.

Price \$2 per barrel, shipped to any part of the United States. Orders will be received through the Rochester P. O. till the stock of potatoes are exhausted, after which notice will be given, and all moneys returned promptly if the potatoes are not forwarded.

H. N. LANGWORTHY,
Irondequoit, near Rochester, N. Y. [12-1f]

Important to Farmers. PORTABLE MILL.

OAKLAND, near Geneva, N. Y., Aug., 25, 1852.

MR. CHARLES ROSS—Dear Sir:—In reply to your letter of the 25th inst., it is a pleasure to speak in commendation of your Patent Conical Mill. To me it has proved valuable for grinding food for my stock, as a few hours labor with this Machine prepares food enough for fifteen head of cows several days. The Mill used by me prepares food for horses, sheep, and swine, grinding and mixing corn, oats and other grains, satisfactorily. It has also produced for my use, our Indian meal, buckwheat meal, and occasionally wheat flour, thus saving the time of teams and men, which otherwise must have been occupied, going several miles to a distant mill, at much expense; it is, therefore a source of economy as well as an inducement to better care of all stock. It affords also one among other resources of convenient and useful labor during stormy weather. My belief is that your Mill will work its way into general use upon farms where stock is raised, and where grist mills are not within a short distance. In my estimation this mill is among the most important machines offered to the farmer.

Respectfully yours,
J. DELAFIELD.
N. B.—Mr. Delafield, has had the Conical Mill in use on his farm for nearly four years.

Any further information respecting this Mill, may be obtained by letter (post-paid) addressed to
CHARLES ROSS, Manufacturer,
2d story Phoenix Building, Aqueduct st., opposite the Arcade, Rochester, N. Y.; or to Joseph Sedgbeer, General Agent for the West.
December, 1852.

BOOK AGENTS WANTED.

GOOD salesmen can earn from \$1 to \$3 per day, in selling AGRICULTURAL BOOKS,

POLITICAL CAMPAIGN BOOKS,

LARGE AND SMALL BIBLES,

POLITICAL AND OTHER PICTURES,

Uncle Tom's Log Cabin; Uncle Tom as it is; Northwood, Mrs. Hale's new book; Cheap Publications; Gold Medals, Gen. Scott and Gen. Pierce; together with other new books.

I will furnish agents with from \$15 to \$30 worth of books for cash, and take back all the unsold books and refund the money. Agents can make from 25 to 100 per cent profit, and in this way are not compelled to keep their stock if not sold. Books can be sent by Express to any address. Money can be safely sent by mail.

D. M. DEWEY,
Oct., 1852.

ArCADE Hall, Rochester, N. Y.

THE GENESEE FARMER FOR 1853.

THE present number completes the volume for 1852. To those who have read the *Farmer* this year, we need not say that we have spared neither labor nor expense to make our paper interesting and valuable. But for our large and almost unparalleled circulation, every volume we print would cost us more than the price charged to subscribers. To our friends and agents everywhere, we tender our acknowledgements for past favors, and hope to increase our indebtedness another year. Let every subscriber spend an hour in calling the attention of his friends and neighbors to the claims of the *Genesee Farmer*, and we shall more than double our circulation the coming year. Let all engage in this work, and form clubs early. Our agents are already sending in their orders, and from every quarter thus far heard from, large additions are made to former clubs.

The Practical and Scientific Farmer's own Paper.

THE GENESEE FARMER,

A MONTHLY JOURNAL OF

AGRICULTURE AND HORTICULTURE,

ILLUSTRATED WITH NUMEROUS ENGRAVINGS OF

Farm Buildings, Domestic Animals, Implements, &c.

VOLUME XIV, FOR 1853.

DANIEL LEE, JAMES VICK, Jr., & JOSEPH HARRIS, EDITORS.

P. BARRY, Conductor of Horticultural Department.

IN issuing a Prospectus for the FOURTEENTH Volume of the *Genesee Farmer*, the Publisher flatters himself that it is too widely known, too extensively circulated, and too well read, to render it necessary to state the design of the work. Those who read the *Farmer* are the best judges of its value, and those unacquainted with it are invited to examine its pages.

The Fourteenth Volume will commence on the 1st of January, and will be issued regularly on the 1st of each month during the year. It will be printed on new type and superior paper, each number containing THIRTY-TWO PAGES, and making at the end of the year a Volume of 854 pages, with title page, index, &c., suitable for binding. The work is appropriately illustrated with beautiful and really valuable engravings of Farm Buildings, Implements, Domestic Animals, Choice Fruits, Flowers, Shrubs, &c.—The Volume for 1852, when bound, will make the most valuable Volume on Agriculture yet published in this country. The Volume for 1853 we design still farther to improve, and hope to be sustained in our efforts by the farmers of the country.

We number among our Contributors, hundreds of the best

Practical Farmers in the country, and our readers have through our pages, the benefit of their wisdom and experience. No thinking man can read any number we issue, without receiving some useful hint in regard to the management of crops, stock, or the orchard, of more value than the price of the volume. The *Genesee Farmer* is by far the Cheapest Agricultural Journal published in America.—Our FORTY THOUSAND SUBSCRIBERS place us ahead of all other Agricultural Journals, and enable us to furnish a paper for the trifling sum of *Three or Four Shillings*, equal to any, both in value and beauty. Its position as the *Cheapest*, and at least one of the *Best Agricultural Journals* in the country, is fully established, and we confidently ask for it that support which it merits from the Farmers, Gardeners, and Fruit Cultivators of the United States. We invite all who feel the importance of sustaining this work, and extending its usefulness, not only to subscribe themselves, but to introduce it to the patronage of their friends.

Fifty Cents a Year, in Advance.

Five Copies for \$2—Eight Copies for \$3, and any larger number at the same rate.

All subscriptions to commence with the year, and the entire volume supplied to all subscribers.

POST-MASTERS, FARMERS, and all friends of improvement, are respectfully solicited to obtain and forward subscriptions.

Subscription money, if properly enclosed, may be sent (post-paid or free) at the risk of the Publisher. Address to

DANIEL LEE,

Rochester, N. Y.

November, 1852.

POSTAGE LAW.—By the new Postage Law, which took effect on the 1st of September last, the postage on the *Genesee Farmer* for one year is as follows,—when paid quarterly in advance:

Anywhere in the State of New York, . . . 5 cts.

Anywhere in the United States, 6 cts.

Sausage Cutters and Stuffers.

A VERY superior article, made of wood and iron, that will cut from 70 to 100 lbs. per hour. Price \$4, \$5 and \$8 each. For sale by LONGETT & GRIFFING, [11-31] No. 25 Cliff St., New York.

French Zinc Paint.

THIS new and beautiful article of Paint is now offered to the trade and public, ground in prepared linseed oil, for the first time in this country. It has been used successfully in France for the last five years, where it has superseded white Lead as a paint.

The French Zinc when properly prepared and used, makes the most brilliant and durable white in use, and is entirely free from all poisonous qualities.

The French Zinc is not more expensive than white lead, and is prepared in such a manner that it requires no farther preparation for use, than to thin it with Turpentine or raw Oil to the consistency of white lead paint.

The French Zinc is very much whiter, and has a better body, than the New Jersey Zinc.

The French Zinc is offered dry, and prepared as above, in quantities to suit purchasers, at the Manufacturer's Depot, No. 17 Buffalo st., Rochester, N. Y.

July, 1852,

M. F. REYNOLDS.

Cheapest Newspaper in the World!
THE ROCHESTER WEEKLY AMERICAN,
(A MAMMOTH FAMILY AND GENERAL NEWSPAPER.)

WILL be afforded, from and after January 1st, 1853, at the unparalleled low price of ONE DOLLAR PER ANNUM, payable *invariably in advance*.

The AMERICAN is the largest and best weekly journal in the State of New York. It contains thirty-six columns, filled with choice original and selected articles, and embracing all those topics which are looked for in the most popular, comprehensive and valuable journals of the day.

Particular attention is paid to the markets of all agricultural products.

Persons desiring to subscribe will please enclose One Dollar, post-paid, to LEE, MANN & Co., Rochester, N. Y., proprietors of the *American*.

The postage on the *Weekly American* (paid quarterly or yearly in advance) is 26 cents a year to any part of the United States. LEE, MANN & CO.

Rochester, N. Y., December, 1852.

THE COUNTRY GENTLEMAN.

A Journal for the Farm, the Garden, and the Fireside. THE publisher of *The Cultivator*, having, since the death of Mr. Downing, disposed of *The Horticulturist*, has determined to carry into effect a project he has had for some years in contemplation, of establishing a Weekly Journal, in connection with *The Cultivator*, to be devoted to the cause of Agriculture, and the Rural Arts generally. In pursuance of this plan, he has issued a specimen number. The regular publication of *The Country Gentleman* will be commenced on the first Thursday of January, 1853, and its scope will embrace:

I. *The Farm.*—Including—1. The Principles of Cultivation, the Preparation of the Soil, and the most approved methods of Culture, of all the crops grown in this country. 2. The Manufacture, Preservation, and Application of Manures. 3. The Description and Illustrative Drawings of all Implements and Machines requisite for the Farmer's use. 4. The Breeding, Rearing, and Management, of all the Domestic Animals, with Engravings of the different breeds.

II. *The Garden and the Orchard.*—1. Descriptions will be given of all the Fruits, of the different varieties, suited to the various sections of the country, together with the best modes of Propagation and Cultivation. 2. Select Lists and Descriptions of Flowers, Shrubs, and Trees, suitable for large and small places, with Directions for their Culture. 3. Special attention will be given to the products of the Kitchen Garden, a department hitherto too much neglected, as there are many plants highly desirable for the table, which have not come into general culture.

III. *The Fireside.*—This department will be of a miscellaneous character, embracing every variety of instructive and entertaining subjects, such as Historical, Geographical and Biographical Notes, Literature, Natural Science, Fables, Poetry, &c., consisting of original articles and selections of a high order.

IV. *Record of the Times.*—Under this head will be given a concise and systematic abstract of the News of the Week, embracing briefly everything of general interest to country residents.

V. *Produce Markets.*—Great efforts will be made to render this department full and complete, and particularly valuable to the Farmer and Produce Dealers. A careful synopsis of the prices of Produce, Wool, Live Stock, &c., at the leading markets, will be given, as well as the condition of crops in the different sections of the country, &c.

It will be the aim of the publisher to make the paper attractive and elegant in its typography and illustrations, choice and select in its contents,—to make it indispensable to the Farmer, and desirable to every one who has a rod of ground to cultivate, or a home to beautify,—and by devoting its columns to Improvement in Agriculture, Elevation in Character, and Refinement in Taste, to render *The Country Gentleman* the standard in its sphere.

TERMS.—*The Country Gentleman* will be printed in quarto form, each number consisting of sixteen pages, and forming an annual volume suitable for binding, of 382 pages, at Two DOLLARS per year when paid in advance, or \$2.50 if not paid in advance.

Specimen numbers sent to all post-paid applicants. Albany, Dec., 1852. LUTHER TUCKER.

Important to Farmers.

IT IS generally conceded by all intelligent farmers that cutting the food for cattle will save from 25 to 30 per cent. Bertholf's Oblique Rotary Corn Stalk, Hay and Straw Cutter, is conceded by all that have used it to be far superior to any other, as it destroys all hard substances in the stalk leaving it soft and easily eaten. It turns very easy and is not liable to get out of order, and, with care, will last an age. It has been awarded Four First Premiums and a Silver Medal, by the American Institute. For further particulars address (post paid) the patentee, J. W. BERTHOLF, Sugar Loaf, Orange Co., N. Y., or LONGFETT & GRIF-FING, 25 Cliff St., New York, who are agents. [11-31]

Premium Dahlias.

THE subscribers offer for sale this Autumn and the ensuing Spring, 10,000 Dahlia Roots, which have proved to be the choicest collection in the States and Canadas. [See records of the Fairs for the last four years.]

Persons commencing the Nursery business, and Amateurs, will find it to their advantage to give us a call, or make enquiries before purchasing elsewhere.

C. J. RYAN & CO.,

Rochester and Charlotte Plank Road Nurseries, Rochester, N. Y. [11-4f]

Emery's Patent First Premium, 1852, RAILROAD HORSE POWER, THRESHING MACHINES, SEPARATORS, &c., Western New York Agency. E. D. HALLOCK, Agricultural Warehouse, No. 50, STATE ST., ROCHESTER, N. Y.

THE Subscriber, late from the Albany Agricultural Works, Warehouse, and Seed Store, where he has been engaged for the past six years, has secured the sole Agency for the sale of Emery's Patent Railroad Horse Power for Rochester and vicinity, so widely and favorably known throughout the country, and which has, without exception, taken every highest premium awarded in the States of Ohio, Michigan, and in New York, for the best Railroad Horse Powers, in 1850, 1851, and again in 1852, also at the Provincial Fair of Canada, recently held at Toronto, was awarded a Diploma and £2, of which the judges highly commend the principle and workmanship of this Power, now offer them at manufacturer's prices, with the transportation added, and subject to the warrantee as follows:

"To work to the satisfaction of the purchasers as represented in Circulars and Catalogues, or to be returned within three months and full purchase money to be refunded." For further particulars see Circulars and Catalogues, which are furnished gratis on application to the subscriber.

The attention of the Farming public is solicited, and a careful investigation into the construction of this Power, and its comparative merits, as well as price, is requested before purchasing elsewhere.

The Wheeler Power is also offered ten dollars cheaper than heretofore by any other agency, and subject to same warrantee as given by others for the same kinds. Samples will be kept constantly on hand, and to insure promptness and avoid disappointments in supplying them, farmers are requested to send in their orders at as early a date as possible.

He will keep for sale, Emery's Seed Planters, the best in use; Circular and Cross Cut Saw Mills, Feed Mills, Corn Stalk and Hay Cutters, Corn Shellers, Churning fixtures, &c., adapted to the Power.

Also, Reapers, Mowing Machines, Grain Drills, Plows, Harrows, Cultivators, Corn Shellers, Hay Cutters, Fan Mills, and agricultural and horticultural implements generally. He will be prepared to furnish dealers with Dunn and Taylor's well known Scythes; also, Manure, Straw, and Hay Forks, snaths, Riddles, and other haying tools, at manufacturers' prices, wholesale and retail.

Particular attention is called to A NEW PLOW, which is believed to be the best cast-iron Plow ever offered, and which is warranted to do better work, with less expense of team than any plow heretofore sold in this vicinity, while the price is less than for any other equally well finished.

The "uniform one-price, cash system" will be adopted, with the prices as low as the cost of articles and just compensation for labor and time will allow. Farmers and others are invited to call and examine the stock of Machines and Implements,—and are assured no effort shall be wanting to meet promptly the wants of a discriminating public. [11-4f] E. D. HALLOCK.

CONTENTS OF THIS NUMBER.

The Philosophy of Tillage—Horse-hoeing Wheat,.....	361
Barn-yard Manure,.....	364
Improved Superphosphate of Lime,.....	366
Theories Examined and Explained,.....	368
British and American Agriculture,.....	370
Pea-culture in Indiana,.....	372
Guano on Potatoes,.....	373
Middlesex Hogs,.....	375
EDITORS' TABLE.—Notices, &c.,.....	382
Impersonality of the Press,.....	382
Inquiries and Answers,.....	383

HORTICULTURAL DEPARTMENT.

Our Native Trees,.....	376
Proceedings of the Pomological Congress,.....	377
New Foreign Pears,.....	380
Fruits from New Hampshire,.....	381
Acknowledgements,.....	381
Answers to Correspondents,.....	388

ILLUSTRATIONS.

Group of Middlesex Hogs,.....	374
Pear, Baron de Mello,.....	380
" Bezy Goubault,.....	380

STEREOTYPED BY J. W. BROWN, ROCHESTER, N. Y.

PREMIUMS FOR 1853.

DURING the year 1852 the editors of the GENESEE FARMER circulated over Eight Hundred Dollars worth of the best Agricultural Books published in the country. These works, in addition to *Forty Thousand Copies Monthly of our own Journal*, scattered all over the land, even to Oregon and California, we believe have exerted, and will continue to exert a very beneficial influence. Their influence is not confined to those who receive them, but is felt by their children, their friends and neighbors. They must increase the knowledge, and consequently the power, and the wealth of those for whose especial benefit we labor. It is our intention to increase the circulation of these works. We do this for the good they accomplish, as well as a slight compensation to our friends—the friends of Rural Improvement—particularly Post-Masters throughout the country, who act as voluntary Agents, without the expectation of pecuniary reward. Below we give our List of Premiums for 1853.

PREMIUMS TO INDIVIDUALS.

1st. THIRTY DOLLARS in AGRICULTURAL BOOKS, to the person who shall send us the largest number of subscribers, at the club price, before the 10th day of April next, so that we may announce the successful competitor in the May number.

2d. TWENTY DOLLARS in *Agricultural Books*, to the person who shall send us the second highest list, as above.

3d. TEN DOLLARS, in *Agricultural Books*, to the person who sends us the third highest list.

In order to make the circulation of *Good Agricultural Books* MORE GENERAL AND BENEFICIAL, and to reward EVERY ONE of the friends of the Genesee Farmer for their exertions in its behalf, we will give to those not entitled to either of the above premiums, the following *Books*, free of postage, or *Extra Papers*, as may be preferred:

1st. To every person who sends SIXTEEN Subscribers, at our club terms of THREE SHILLINGS EACH, one extra copy of the Farmer.

2d. To every person sending for TWENTY-FOUR Copies, as above, any Agricultural Book valued at 50 cents, or two extra copies of the Farmer.

3d. To every person ordering THIRTY-TWO Copies of the Farmer, any Agricultural Book worth 75 cents, or three extra copies of the Farmer.

4th. For FORTY, any Agricultural Book valued at \$1, or four extra copies of the Farmer.

5th. For FORTY-EIGHT, any Agricultural Book worth \$1.25, or five extra copies of the Farmer.

For larger numbers, Books or papers given in the *same proportion*. To *save cost* to our friends, we *pre-pay postage* on all Books sent as premiums, and persons entitled will please state whether they wish Books or extra papers, and make their selection when they send orders, if they desire Books; or if they have not obtained as many subscribers as they intend to, we will delay sending until the club is full, if so requested. We do not require that all the papers of a club should be sent to one Post Office. If necessary for the convenience of subscribers, we are willing to send to as many different Offices as there are members of the Club. We write the names on each paper, when a number is sent to the same Office, if so desired, but when convenient Post-Masters would confer a favor by having the whole number ordered at their own office, sent to their own address.

COUNTY PREMIUMS.

To aid as much as possible in establishing *County Agricultural Libraries*, we offer the following Premiums, which we hope will aid in the more general establishment of County Libraries:

1st. We will give an AGRICULTURAL LIBRARY worth FORTY DOLLARS to the County in which the *greatest number of copies of the Genesee Farmer is taken by the 10th of April next*. This Library to be kept as a County Agricultural Library, under the care of the Agricultural Society.

2d. To the County in which the next greatest number is taken, an *Agricultural Library worth TWENTY-FIVE DOLLARS*, on the same conditions as above.

As the above two premiums will probably be taken in the *State of New York*, and as we wish to give our friends in other States an equal chance in the competition, we offer the same premiums to COUNTIES OUT OF THE STATE OF NEW YORK, thus:

1st. To the *County out of the State of New York* in which the greatest number of copies of our paper is taken, an Agricultural Library worth FORTY DOLLARS.

2d. To the next *County out of N. York*, a Library worth TWENTY-FIVE DOLLARS.

As all Subscriptions commence anew with the year, places where the Farmer was never before taken will stand an equal chance in the competition for premiums. Individuals will receive the premiums to which they may be entitled for their individual benefit, as a compensation for their personal exertions, and the numbers they send will be credited to the Counties where the papers are sent, so that the premiums to individuals will not at all interfere with the County premiums, or the County with individuals.

BACK VOLUMES of the Farmer will be furnished, if desired, and counted the same as new subscribers. We shall keep a correct account of the subscribers sent by each person and county. In the May number we shall announce the premiums. *Libraries* will be forwarded per order, immediately after the announcement, and persons or societies can select their own books, or leave the selection to us. Specimen numbers, show-bills, &c., sent to all post-paid applicants. All letters must be paid or free. Subscription money, if properly enclosed, may be mailed at our risk.

THE HORTICULTURIST FOR 1853.

THE melancholy death of A. J. DOWNING deprived the readers of the *Horticulturist* of the labors of one whose essays they had so long read with unmingled pleasure and profit. Since that sad event became known, the great question among the horticulturists of the country, who have evinced a deep interest in the matter, has been, who should succeed to this important post. With singular unanimity, it has been assigned to P. BARRY, of Rochester, who has been urgently solicited in various ways, both publicly and privately, to take charge of the work. This, from the nature of his engagements, he could not do while the *Horticulturist* was published at Albany. The subscriber, who has long been connected with Mr. BARRY, as one of the editors of the *Genesee Farmer*, has therefore purchased the *Horticulturist*, and after the conclusion of the present volume it will be PUBLISHED AT ROCHESTER, and EDITED BY P. BARRY, assisted by many of the best Horticulturists of the country, whose communications will materially add to its value. The ARCHITECTURAL DEPARTMENT will be conducted by gentlemen of ability and reputation.

To render the work accessible to a greater number, and consequently more beneficial, the price will be reduced to TWO DOLLARS per year, *in advance*, and at the same time various improvements made. Each number will contain a full page engraving of some new, rare and valuable fruit or flower, drawn from nature, and engraved in a style not excelled.

Still further to add to the value of the work and meet the improving taste and increasing wants of the Horticultural community, we shall also publish an edition with COLORED PLATES, each number containing a full page engraving of some new, rare and valuable fruit or flower, correctly colored from nature, by the best living artists in this line. This will be a new and important feature, in this country, and must command the attention and patronage of both professional and amateur Horticulturists. As the number of colored plates we can furnish will be limited, from the care and time required in their preparation, those who wish the *Colored Edition of the Horticulturist for 1853* will do well to order immediately. Price with colored plates, FOUR DOLLARS, *in advance*.

All who cultivate fruit or flowers should read the *Horticulturist*, as it is devoted entirely to Horticulture and its kindred arts Landscape Gardening and Rural Architecture, and will keep its readers advised of everything new on the subject, either in Europe or America.

It will be our aim not only to make the *Horticulturist* superior both in style and matter to any work of the character in this country, but equal to any of the Horticultural Journals of Europe, and we confidently ask the aid and co-operation of the Horticulturists of the country. The January number will be issued early in December, and specimen numbers will be sent to all who will interest themselves in its behalf. The volume to commence on the 1st of January, 1853.

November 1, 1852.

Address

J. VICK, JR., PUBLISHER,
Rochester, N. Y.



