



3 1761 06706764 5

Frank F. Payne

How to Attract the Birds

Canadian Society for the Protection
of Birds



Zoo1
Aves
P

Canadian Society for the Protection of Birds

INCORPORATED UNDER THE ONTARIO COMPANIES ACT
TORONTO, JANUARY 28, 1915

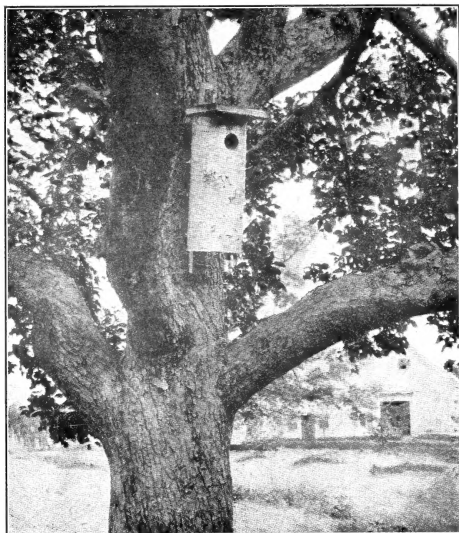

Fig. 2, Nesting Box (Fig. 1) in place.

HOW TO ATTRACT THE BIRDS

BY

FRANK F. PAYNE

Secretary of the Dominion Meteorological Service

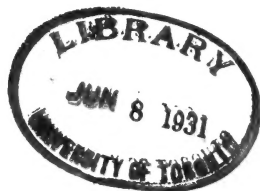

TORONTO :

Printed and Published by A. T. WILGRESS, Printer to the King's Most Excellent Majesty

1917

Digitized by the Internet Archive
in 2007 with funding from
Microsoft Corporation



HOW TO ATTRACT THE BIRDS

By

FRANK F. PAYNE

Secretary of the Dominion Meteorological Service

After much discussion, careful observation, and tabulation in which the number of noxious insects destroyed each day by birds, and found in their crops and stomachs has actually been counted, the public has come to the realization of the fact that not only do the birds add enormously to the wealth of a nation, but that man could not live upon this earth without them. In the more enlightened countries laws have been passed for their protection, and it is the duty of the public not only to do what they can to further this object, but to endeavour to attract the birds. In Canada, owing to the clearing of the forests over large areas, the birds are left without nesting holes, always found in decayed trees, consequently the most useful insectivorous birds are now found chiefly in or near such forests as remain. In order to induce them to return to the open country, it is absolutely necessary to provide artificial nesting holes or boxes, and it has been found that many of these birds will readily take to nesting boxes. It is of course, the duty of the state to provide boxes, and doubtless before long it will be considered as much a part of the work of agricultural departments, as instructing the farmer regarding the value of draining or the best grain to grow. In the vicinity of our cities and towns where quantities of fruit and vegetables are grown, and insectivorous birds are so much needed, the conditions for nesting holes are even worse, as all dead trees are cut down.

In addition to the economic value of birds is the great pleasure they add to the life of mankind, and if we would keep them about us this can be done by a small expenditure in nesting boxes, for it has been found over and over again that the birds do not despise even the humblest cottage in the centre of a large city if so provided.

In order to further attract the birds to our parks and gardens, clean water for bathing and drinking should be provided, and this may be done with shallow trays sunk in the ground and sloping so that the water is quite shallow at the upper end. Seed trays will help enormously, and quite open hanging baskets fitted with bath, drinking and seed trays are sometimes provided. Suet, meat, fat and sunflower seeds will attract many birds and induce them to stay. As the destruction by cats is very great, lovers of birds should discourage the keeping of cats as pets, and all stray cats should be destroyed. Material for nests such as wool and soft clay scattered about will also help to attract the birds.

There are so called bird houses of many shapes and sizes, but perhaps the most common and least fitting to its surroundings is that fashioned like a human dwelling on the top of a pole. These, of course, will attract the birds if nothing better is provided, but they are expensive, and it is our object to suggest, if possible, the most natural and least expensive boxes which also may be made by an amateur carpenter.

These should be made to last so that the same birds may return to them each Spring. The floor should give plenty of room for the nest, joints should be tight in order to prevent draughts or the entrance of rain, entrance holes should be countersunk or slope upwards so that wet may not enter; there should be a small hole through the floor of the house to drain off any water which may enter, entrance holes should be quite small so that as far as possible sparrows may be prevented from taking possession. Painted boxes are not advised, but if paint is used it should be of a dull colour. The more rustic looking the box the more it will attract the birds. As birds return to the same hole in a tree year after year, from which they will remove portions of the nest, and as in Canada the cold of winter destroys most insect pests found in nests, cleaning is not so necessary as elsewhere. Clean boxes, however, will doubtless be preferred, and sides or tops may be hinged or made movable so that this may be done. If the box tips forward a little this will help to keep out rain, and it should never lean backward. The roof should slant and should overhang enough to keep rain clear, and also keep the sun from shining on the young. As the roof is liable to warp it is a good plan to have one or more cross pieces of wood strongly nailed to prevent this. If nesting boxes are placed on poles instead of on trees a metal guard can be attached lower down to prevent cats from climbing

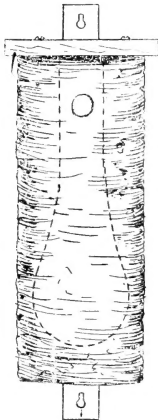

Fig. 1.

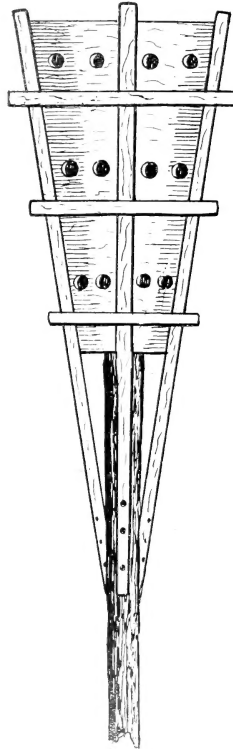

Fig. 3.

to the nests as shown in Fig. 11. Perches attached to nesting boxes are quite unnecessary, and if placed near the entrance hole will encourage sparrows.

The most natural and durable boxes used almost entirely in Europe and largely in the United States, are made of a section of a branch or tree. These are about six inches in diameter and from one to two feet in length, with the bark on as shown in the cut Fig. 1 and 2. These pieces of timber are hollowed out by machinery

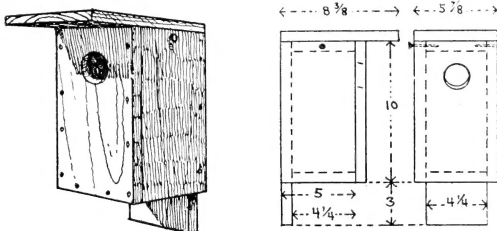

Fig. 4.

with an expanding cutter, but they can be made by splitting a straight grained block and gouging out the hollow in both halves and then joining them with screws. The size of the box and the height of the entrance hole above the floor will depend upon the birds for which the box is intended as shown in the table below. Flickers, Woodpeckers, Bluebirds, Chickadees, and several other birds prefer these boxes to any other, and as they can usually be purchased for fifty cents or less, they are much in favour.

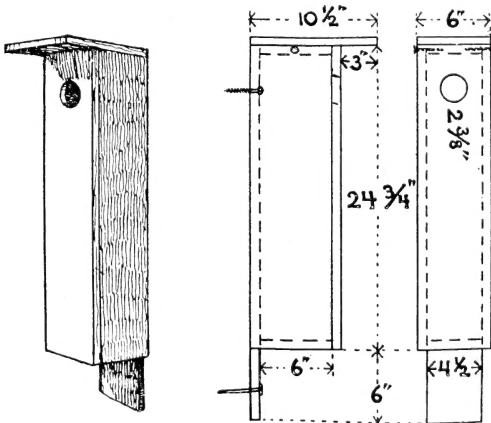

Fig. 5.

Of compartment nesting boxes such as would be occupied by the purple martin we would recommend one in the form of an inverted cone resting in a rough framework erected on a pole as shown in Fig. 3.

Smaller boxes for Bluebirds, Wrens, etc., can be made cheaply in all shapes and sizes, either of bark or waste slabs covered with bark. A very effective box is made of half or the whole circle of bark taken from a limb or trunk of a tree and roofed

with bark or other material as shown in Fig. 10. Mr. E. H. Forbush in his circular issued by the State Board of Agriculture for Massachusetts, from which we have also taken most of our illustrations, makes the following suggestions for making of these boxes.

“An incision is made on the side intended for the back of the box, through both outer and inner bark, from the top to the bottom of each section: then, on the opposite side, some two or three inches from the top, there is bored through

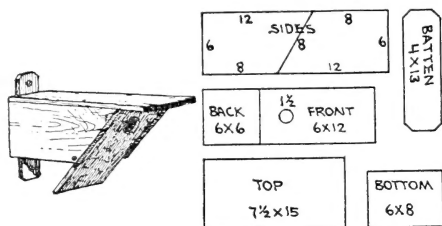

Fig. 6.

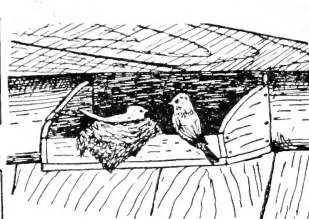

Fig. 7.

the bark, with an auger or extension bit, a hole of the size desired for the entrance. If such tools are not at hand the aperture may be cut with gouge, a chisel or even a knife. Next, a wedge-shaped stick is inserted into the incision at the back and under the inner bark, to start it off, and with this implement it is peeled very carefully. In peeling birch one should be careful not to separate the inner and outer layers of the bark. Caution should be used when working about knots or rough places. The bark will make the sides of the box, and two sections each an inch thick sawed from the ends of the barked log, will make the top and bottom. Now the bark is tacked to the bottom and top. The bark will draw apart somewhat

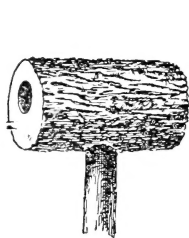

Fig. 8.

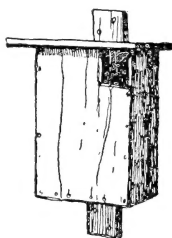

Fig. 9.



Fig. 10.



Fig. 11.

at the back in drying but this aperture may be covered when the box is put up by nailing or screwing a short stick or pole over the opening on the back, which stick in turn may be nailed or screwed to the supporting tree, building or pole. To make the roof watertight, a piece of cotton cloth, duck or denim may be put on, tacked down over the edge and painted, or a piece of roofing paper may be used.”

Excellent boxes can also be made with boards as shown in Figs. 4 and 5, but if possible, the wood should be covered with bark. If this is not possible, however, it should be stained and not painted. Other nesting boxes easily made are shown in

Figs. 6, 8, and 9, the former having the reputation of being cat proof, and the latter being preferred by Owls.

For Robins, Swallows and Phœbes, a box or shelf should be provided, having the front end and top or all sides open as shown in Fig. 7, where two sides are given. These should be erected under a verandah or eave.

A nesting box can be made with a tomato can by fitting in the open end a round piece of wood with a hole in it. Such boxes are very cheap, but they will not be accepted where there are other nesting holes to be found.

There are many nesting boxes exposed for sale, and doubtless many will be accepted by the birds, but in order to have any degree of success they must be made correctly in accordance with long experience, and the Canadian Society for the Protection of Birds, Toronto, will be pleased to offer suggestions to either those who propose to purchase or construct boxes themselves.

The table of nesting box dimensions below was issued by the Department of Agriculture at Washington, and it is recommended for boxes used in Canada.

DIMENSIONS OF NESTING BOXES

Species	Floor of Cavity	Depth of Cavity	Entrance above Floor	Diameter of Entrance	Height above Ground
	Inches	Inches	Inches	Inches	Feet
Bluebird.....	5 x 5	8	6	1½	5 to 10
Robin.....	6 x 8	8	*	*	6 to 15
Chickadee.....	4 x 4	8 to 10	8	i 1½	6 to 15
Whitebreasted Nuthatch....	4 x 4	8 to 10	8	i 1¼	12 to 20
House Wren.....	4 x 4	6 to 8	1 to 6	7/8	6 to 10
Barn Swallow.....	6 x 6	6	*	*	8 to 12
Martin.....	6 x 6	6	1	2½	15 to 20
Song Sparrow.....	6 x 6	6	**	**	1 to 3
Phœbe.....	6 x 6	6	*	*	8 to 12
Crested Flycatcher.....	6 x 6	8 to 10	8	2	8 to 20
Red-headed Woodpecker.....	6 x 6	12 to 15	12	2	12 to 20
Screech Owl.....	8 x 8	12 to 15	12	3	10 to 30
Barn Owl.....	10 x 18	15 to 18	4	6	12 to 18
Flicker.....	7 x 7	16 to 18	16	2½	6 to 20
Hairy Woodpecker.....	6 x 6	12 to 15	12	1½	12 to 20
Downy Woodpecker.....	4 x 4	8 to 10	8	1¼	6 to 20

* One or more sides open.

** All sides open.

The Secretary,

CANADIAN SOCIETY FOR THE PROTECTION OF BIRDS.

(MacLean Building)

149 University Avenue,

Toronto, Can.



Zool
Aves
P

Author Payne, Frank F

Title How to attract the birds.

**University of Toronto
Library**

**DO NOT
REMOVE
THE
CARD
FROM
THIS
POCKET**

Acme Library Card Pocket
Under Pat. "Ref. Index File"
Made by LIBRARY BUREAU

