



OCCASIONAL PAPERS

INTRON 2 OF THE ALCOHOL DEHYDROGENASE GENE (*ADH1-I2*): A NUCLEAR DNA MARKER FOR MAMMALIAN SYSTEMATICS

BRIAN R. AMMAN, J. DELTON HANSON, LISA K. LONGHOFFER,

STEVEN R. HOOFFER, AND ROBERT D. BRADLEY

ABSTRACT

DNA sequences from a novel nuclear marker (2nd intron of the vertebrate alcohol dehydrogenase gene, *Adh1-I2*) and the mitochondrial cytochrome-*b* gene (*Cyt-b*) were examined in 41 species and six genera of rodents (one *Holochilus*, 13 *Neotoma*, six *Oryzomys*, one *Ototylomys*, 19 *Peromyscus*, and one *Tylomys*). The *Adh1-I2* dataset was characterized by having a significant level of phylogenetic signal ($P < 0.01$) and a low level of homoplasy (consistency index = 0.78, retention index = 0.89). Based on parsimony, maximum likelihood, and Bayesian analyses, the *Adh1-I2* results were congruent with results from *Cyt-b* and other types of data, and generally were accompanied by high statistical support. All phylogenetic relationships at and above the genus level were strongly supported. Furthermore, compared with *Cyt-b*, the *Adh1-I2* dataset provided supported resolution to more species-level relationships within *Neotoma*, *Peromyscus*, and *Oryzomys*, despite fewer overall characters (489 *Adh1-I2*; 1,143 *Cyt-b*) and fewer parsimony informative characters (126 *Adh1-I2*; 464 *Cyt-b*). Overall, results of this study indicated that *Adh1-I2* DNA sequences are useful for addressing phylogenetic relationships within and among the Sigmodontinae and Neotominae. The slower rate of molecular evolution observed in *Adh1-I2* sequences, coupled with low levels of homoplasy and strength of resolution for supraspecific relationships, indicated that this marker may be useful for resolving phylogenetic relationships at low to intermediate taxonomic levels in mammals.

Key words: alcohol dehydrogenase gene, cytochrome-*b* gene, molecular systematics, rodents

INTRODUCTION

The use of nucleotide sequence data has greatly enhanced our knowledge of mammalian systematics. In mammals, the majority of molecular-based phylogenies have been estimated by analysis of maternally inherited, mitochondrial DNA (mtDNA) sequences, especially protein coding genes. Advantages in using mtDNA sequences in phylogeny reconstruction include: technical ease in DNA isolation and polymerase chain reaction amplification, manageable sequence lengths (generally <1,200 base pairs, bp), ease of alignment, availability of "universal" primers, differential rates of molecular evolution in specific regions of the molecule, significant phylogenetic signal, and substantial databases (GenBank, EMBL, etc.) of comparative material. However, there are drawbacks to mtDNA that can result in a misrepresentation of the true phylogeny, including retention of ancestral polymorphisms, incomplete lineage sorting, differential rates of evolution among lineages, and hybridization (Avice 1994; Hillis et al. 1996; Pritchitko and Moore 2000). Likewise, base composition of mtDNA protein coding genes (excess of C and A at the 3rd positions - Anderson et al. 1981; Roe et al. 1985; Desjardins and Morais 1990; Pritchitko and Moore 2000; Ballard et al. 2002) may result in codon bias and homoplasy (Pritchitko and Moore 2000) leading to a biased reconstruction of ancestral sequences (Collins et al. 1994; Lockhart et al. 1994; Perna and Kocher 1995). Although some of these drawbacks can be addressed, nuclear DNA sequences are highly desirable as an alternative dataset to independently test mtDNA hypotheses and to essentially counteract criticisms of mtDNA.

Historically, nuclear DNA sequences have been used to address phylogenetic questions pertaining to relationships above the genus level (e.g., rRNA genes - Gouy and Li 1989; Perasso et al. 1989), principally because nuclear sequence markers with levels of variation suitable for resolving relationships among closely related species or genera are scarcely known and have been difficult to discover. Intron markers are an obvious and likely source of nuclear variability suitable for low- or intermediate-level phylogenetics. With the exception of some conserved areas, such as regulatory sites (Jackson and Hoffmann 1994), most nucleotide positions within introns are adaptively neutral and

independently distributed and generally are evolving faster than those within exons, thus increasing their potential in population genetics or phylogenetic analysis of closely related species (Ballard et al. 2002; Pritchitko and Moore 2000; Slade et al. 1994; Wickliffe et al. 2003). In addition, introns of various sizes are relatively abundant in the nuclear genome, and usually primer design in conserved areas of adjacent exons enable efficient amplification across taxonomic boundaries. In vertebrates, several introns have been shown to be useful in studies at or below the genus level (Pritchitko and Moore 1997, 2000; Oakley and Phillips 1999; Lavoué et al. 2003; Reeder and Bradley 2003; Johansson and Ericson 2004; Helbig et al. 2005), and others have been shown to be relatively invariant at or below the species level (Wickliffe et al. 2003; Carroll and Bradley 2005). Alternatively, Fonseca et al. (in press) and Porter et al. (in review) found intron sequences useful for resolving relationships among closely related species of bats.

The purpose of this study was to examine the phylogenetic utility of DNA sequence data from the 2nd intron of the alcohol dehydrogenase gene I (*Adh1*) obtained for 41 species in six genera of rodents. *Adh* genes, in mammalian systems, code for dimeric zinc-metallo enzymes that catalyze oxidization of alcohols to aldehydes or ketones (Szalai et al. 2002). Seven distinct classes are recognized in vertebrates (Duester et al. 1999; Dolney et al. 2001; Szalai et al. 2002), six of which are present in mammalian species (Duester et al. 1999; Szalai et al. 2002). In rodents, four *Adh* classes (I, II, III, and IV) have been reported (Crabb and Edenberg 1986; Zhang et al. 1987; Park and Plapp 1991; Bradley et al. 1993, 1998; Duester et al. 1999; Szalai et al. 2002) and are controlled by six genes, *Adh1*, *Adh2*, *Adh3*, *Adh4*, *Adh5a*, and *Adh5b* (Duester et al. 1999; Dolney et al. 2001; Szalai et al. 2002). *Adh1* is approximately 13 kilobase pairs in length (Crabb et al. 1989), contains nine exons (coding between 6 and 87 amino acids) and eight introns (ranging from 91 bp to 3.6 kilobase pairs; Zhang et al. 1987). Hereafter, in referring to the 2nd intron, we follow the recommended nomenclature (*Adh1*-I2) of vertebrate alcohol dehydrogenases outlined in Duester et al. (1999).

MATERIALS AND METHODS

Specimens examined.—Specimens examined, GenBank accession numbers, and information associated with museum vouchers are listed in Appendix I. Complete sequences for *Adh1-12* and cytochrome-*b* (*Cyt-b*) were obtained for 41 individuals and 10 individuals, respectively, and were deposited in GenBank. In addition, 31 *Cyt-b* sequences were retrieved from GenBank. *Holochilus chacarius* was designated as the outgroup taxon in phylogenetic analyses of *Adh1-12* and *Cyt-b* data, as previous morphological and molecular studies agree that *Holochilus* may be outside the remainder of taxa in this study (reviewed in Musser and Carleton 2005). Sequence data were evaluated and relationships were inferred among the 40 ingroup species (13 *Neotoma*, six *Oryzomys*, one *Ototylomys*, 19 *Peromyscus*, and one *Tylomys*) representing the subfamilies Neotominae and Sigmodontinae (Musser and Carleton 2005).

Adh1-12 data.—Genomic DNA was isolated from approximately 0.1 g frozen muscle or liver tissues by the method of Smith and Patton (1999). Polymerase chain reaction (PCR; Saiki et al. 1988) primers for *Adh1-12* (Table 1) were designed from conserved regions in exons 2 and 3 based on sequences from *Homo* (Ikuta et al. 1986), *Geomys* (Bradley et al. 1993, 1998), *Mus* (Zhang et al. 1987), *Peromyscus* (Zheng et al. 1993), and *Rattus* (Crabb et al. 1989). A nuclear fragment approximately 650 bp long, encompassing the entire *Adh1-12*, was amplified in all six genera using two forward primers (2340-I or EXON II-F) and two reverse primers (2340-II or EXON III-R). PCR thermal profiles

varied only slightly among genera examined: initial denaturation at 95°C for 2–10 min, followed by 25–30 cycles of denaturation at 95°C for 30–60 sec, annealing ramped from 52–53°C down to 46–48°C and back up to 52–53°C at a rate of 0.6°C/sec, extension at 73°C for 1.5 min, and a final extension cycle of 73°C for 4 min. Ramping speed between all three phases of PCR was set at a rate of 1°C/sec. Reaction concentrations (35 µl volume) included approximately 300 ng genomic DNA, 0.07 mM dNTPs, 2.86 mM MgCl₂, 3.5 µl 10X buffer, 0.286 µM primer, and 1.25–1.5 U enzyme (FailSafe PCR Enzyme Mix, Epicentre, Valencia, California). In some reactions, 1.5 U AmpliTaq Gold (PE Applied Biosystems, Foster City, California) was used with an initial denaturation time of 10 min.

PCR products were purified using the QIAquick PCR purification kit (Qiagen, Valencia, California) and sequenced with Big-Dye version 3.1 chain terminators (Applied Biosystems, Inc., Foster City, California). Appropriate external primers and four internal primers (350F, 350R, 410F, 410R; Table 1) were used to sequence each strand entirely. Thermal profile for cycle sequencing was modified from the manufacturer's recommendation: 25–30 cycles of 95°C for 30 sec denaturation, 50°C for 20 sec annealing, and 60°C for 3 min extension. Sequencing reactions were precipitated and concentrated with standard isopropanol methods, resuspended in 15 ml Hi-Di Formamide, and electrophoresed on an ABI 3100-*Avant* Genetic Analyzer (Applied Biosystems, Inc., Foster City, California). Sequencher 3.0 software (Gene Codes, Ann Arbor, Michigan) was

Table 1. Primer sequences used in the polymerase chain reaction (PCR) amplification and sequencing of the alcohol dehydrogenase locus. Sequences are given in a 5' to 3' orientation.

Primer	Sequence
2340-I (5' PCR primer)	GTAATCAAGTGCAAAGCAGCTG
2340-II (3' PCR primer)	TAACCACGTGGTCATCTGAGCG
EXON II-F (5' PCR primer)	GTAATCAAGTGCAAAGCRGCYYTRTGCGAG
EXON III-R (3' PCR primer)	GACTTTATCACCTGGTTTYACWSAAGTCACCCC
350F (internal sequencing primer)	GTGCTAAACATCTTGATTCCRAAAG
350R (internal sequencing primer)	GCTTTTGGAATCAAGATGTTTAG
410F (internal sequencing primer)	CTATAGCACAGCACAGC
410R (internal sequencing primer)	TGCTGTGCTGTGCTATAG

used to assemble and proofread resultant fragments. Base calling ambiguities on single strands were resolved by choosing the call on the cleanest strand or by using appropriate IUB ambiguity code if both strands showed the same ambiguity.

Because provisional statements of homology (i.e., sequence alignment) are of special concern for non-coding DNA sequences possibly containing insertion/deletions (Giribet and Wheeler 1999), and because many parameters can affect multiple-sequence alignment and resulting phylogenetic inference (DeSalle et al. 1994; Hickson et al. 2000; Lutzoni et al. 2000; Wheeler 1995), two multiple-sequence alignments of *Adh1-I2* data were performed independently in Clustal X software (Thompson et al. 1997): one using a 30:4 gap cost-ratio, the other using a 5:4 gap cost-ratio (Van Den Bussche and Hofer 2001; Van Den Bussche et al. 2002). Alignments subsequently were examined using MacClade software (version 4.05; Maddison and Maddison 2002), ambiguously aligned sites were delimited following methods of Hofer and Van Den Bussche (2003), and analyses were performed with and without those sites.

Cyt-b data.—Sequences of the entire (1,143 bp) mitochondrial *Cyt-b* gene were obtained from each of the 41 species to facilitate comparison to the *Adh1-I2* data. PCR and sequencing primers, conditions, and thermal profiles followed Edwards and Bradley (2002) and Bradley et al. (2004a). Sequence alignments were performed manually and checked in MacClade software (version 4.05; Maddison and Maddison 2002) to ensure there were no insertions/deletions or stop codons in the protein-coding gene.

Data analysis.—Analyses were performed in PAUP* 4.0b10 software (Swofford 2002) or MrBayes 2.01 software (Huelsenbeck and Ronquist 2001). Nucleotide positions were treated as unordered, discrete characters (A, C, G, and T), multiple states as polymorphisms, and gaps as missing. Nucleotide sequences from both *Adh1-I2* and *Cyt-b* were evaluated four ways: 1) base frequencies, number of transitions, number of transversions, and number of substitutions per 100 bp were estimated within and compared among the five ingroup genera; 2) levels of phylogenetic signal were estimated using

the g_1 -statistic (Hillis and Huelsenbeck 1992) for 100,000 randomly drawn trees; 3) genetic distances (uncorrected "p") were obtained and compared using pairwise comparisons of taxa; and 4) maximum likelihood, Bayesian likelihood, and parsimony analyses were performed and compared among taxa.

Based on hierarchical likelihood ratio tests (hLRTs) in Modeltest software (Posada and Crandall 1998), the following models of nucleotide substitution and associated parameters best fit the data: *Adh1-I2*—Hasegawa-Kishino-Yano (HKY) model with allowances for gamma distribution of rate variation (G), $ti/tv = 2.308$, $\pi A = 0.301$, $\pi C = 0.191$, $\pi G = 0.183$, $\pi T = 0.325$, $\alpha = 1.662$; *Cyt-b*—general time reversible (GTR) with allowances for G and proportion of invariant sites (I), $R_{AC} = 1.310$, $R_{AG} = 10.479$, $R_{AT} = 2.473$, $R_{CG} = 0.708$, $R_{CT} = 32.137$, $\pi A = 0.375$, $\pi C = 0.343$, $\pi G = 0.079$, $\pi T = 0.203$, $\alpha = 0.687$, $p_{inv} = 0.456$. The HKY + G model best fit the *Adh1-I2* data with and without ambiguous characters, although specific model parameters differed slightly; *Adh1-I2* values reported were calculated without ambiguous characters.

Bayesian analyses were run at least two million generations with four Markov-chains, random starting trees for each chain, and trees sampled every 100th generation. For each data set, two independent analyses were run to assess whether chains converged on the same posterior probability distribution and whether likelihood values became stable (Huelsenbeck et al. 2002). Model parameters were treated as unknown variables (with uniform priors) to be estimated in each Bayesian analysis (Leaché and Reeder 2002). Burn-in values (initial set of unstable generations to be ignored) were based on empirical evaluation of likelihoods converging on stable values. Clade reliabilities were assessed using posterior probabilities (values ≥ 0.95 regarded as significant).

Maximum likelihood analyses were performed with full heuristic searches, neighbor-joining starting trees, and tree-bisection-reconnection branch swapping. Parsimony analyses, with all characters and substitution types given equal probabilities (i.e., unweighted), were conducted with full heuristic searches with 10 random additions, starting trees

by simple addition, and tree-bisection-reconnection branch swapping. Clade reliabilities were assessed in parsimony analyses using bootstrapping methods with 250 iterations (Felsenstein 1985). Due to pro-

hibitive computation time under maximum likelihood, bootstrapping was performed for 100 iterations for just the *Adh1-12* dataset (100 iterations). Values ≥ 70 were regarded as strong support.

RESULTS

Adh1-12 data.—Complete sequence of *Adh1-12* averaged 530 bp for the 41 rodents examined, ranging from 494 (*Holochilus*) to 576 (*Peromyscus californicus*). Alignment of sequences resulted in 614 aligned sites (125 ambiguously aligned) with the 5:4 gap cost-ratio, and 607 aligned sites (133 ambiguously aligned) with the 30:5 gap cost-ratio, corresponding to the insertion of more gaps with a lower cost ratio. As results from all subsequent analyses, phylogenetic analyses in particular, essentially were identical regardless of alignment and with and without the ambiguously aligned characters excluded, only results based on the 5:4 alignment with 125 ambiguous characters removed are reported and discussed.

After removing 125 ambiguous characters, 489 characters were available for analysis, of which 260 were constant and 126 were parsimony informative. Overall nucleotide frequencies varied slightly among the three genera (Table 2), averaging 30.47% (A), 17.51% (C), 17.94% (G), and 34.08% (T). The transition to transversion ratio was approximately 2.28 to 1. The number of heterozygous sites ranged from zero (37 taxa) to three (*N. stephensi*, *N. mexicana*, and *O. perenensis*), with a mean heterozygosity of 0.34 per taxon. The g_i statistic was skewed significantly left

(-0.65; $P < 0.01$), indicating strong phylogenetic signal (Hillis and Huelsenbeck 1992).

Cyt-b data.—Complete sequences of *Cyt-b* (1,143 bp) were included for the 41 rodents examined herein. Sequence alignment was unequivocal and contained no stop codons. Of the 1,143 characters, 589 were constant and 475 parsimony informative. Nucleotide variation was distributed across codon positions as expected for protein-coding genes (1st position, 111; 2nd position, 37; 3rd position, 327). Overall nucleotide frequencies varied slightly among the three genera (Table 2), averaging 31.67% (A), 28.15% (C), 12.45% (G), and 27.74% (T), and transition to transversion ratio was approximately 2.68 to 1. The g_i statistic was skewed significantly left (-0.49; $P < 0.01$), indicating strong phylogenetic signal (Hillis and Huelsenbeck 1992).

Phylogenetic analyses.—For *Adh1-12* and *Cyt-b*, Bayesian likelihoods reached stability before 100,000 generations (i.e., burn-in = 1,000), thinning the data to 19,000 sample points. Topology and posterior probabilities for nodes and model parameters for all sets of runs agreed. Maximum likelihood analysis resulted in a single best tree for both *Adh1-12* (LnI = -2,718.63) and *Cyt-b* (LnI = -14,379.92) data sets (Figs. 1 and 2).

Table 2. Nucleotide base composition (A, C, G, and T), number of transition substitutions per 100 bp (#Ti/100 bp), number of transversion substitutions per 100 bp (#Tv/100 bp), and the uncorrected *p* distance (*p* Dist) for the 3 genera possessing multiple taxa. All values were averaged across taxa within each of the 3 genera for intron 2 of the alcohol dehydrogenase locus (*Adh1-12*) and the mitochondrial cytochrome-b gene (*Cyt-b*).

Taxon/Sequence	% A	% C	% G	% T	# Ti/100 bp	# Tv/100 bp	<i>p</i> Dist
<i>Peromyscus Adh1-12</i>	30.16	17.48	18.58	33.77	2.31	1.09	3.41%
<i>Peromyscus Cyt-b</i>	31.72	27.45	12.62	28.21	8.38	2.79	12.29%
<i>Neotoma Adh1-12</i>	30.35	17.73	17.59	34.33	1.67	0.50	2.22%
<i>Neotoma Cyt-b</i>	32.24	28.93	12.43	26.40	8.73	2.90	11.61%
<i>Oryzomys Adh1-12</i>	31.34	17.33	16.97	33.37	4.48	2.10	6.70%
<i>Oryzomys Cyt-b</i>	31.16	28.43	11.98	28.43	7.73	5.75	14.00%

Parsimony analysis resulted in 62 most-parsimonious trees (length = 363, CI = 0.78, RI = 0.89) and a single most-parsimonious tree (length = 3,321, CI = 0.28, RI = 0.48) for *Adh1-12* and *Cyt-b*, respectively.

There were some topological differences within and between datasets and between the three optimality criteria, although only one difference between datasets represented a statistically supported conflict (i.e., $\geq 70\%$ bootstrap value, ≥ 0.95 Bayesian posterior probability).

This conflict involved the sister species relationships of *N. albigula*, *N. leucodon*, and *N. micropus*. *Adh1-12* supported a *N. albigula*/*N. leucodon* sister relationship, whereas *Cyt-b* supported a *N. leucodon*/*N. micropus* sister relationship (Figs. 2 and 3). Overall, statistically supported topologies obtained from all optimality criteria agreed within and between datasets, supporting monophyly of *Neotoma* and *Peromyscus* and diphyly of *Oryzomys* (Fig. 3).

DISCUSSION

Results of this study indicated that *Adh1-12* DNA sequences are useful for addressing phylogenetic relationships within and among the Sigmodontinae and Neotominae. Based on the g_i statistic and consistency and retention indices, the *Adh1-12* dataset had a greater overall phylogenetic signal and less homoplasy than the *Cyt-b* dataset. *Adh1-12* sequences also provided statistically supported resolution to slightly more relationships than *Cyt-b* (Fig. 3). For example, *Adh1-12* strongly supported all relationships examined at and above the genus level, including monophyly of *Neotoma* and *Peromyscus* and a sister relationship between *Ototylomys* and *Tylomys*, relationships that have been documented repeatedly by analysis of morphological and DNA sequence data (Carleton 1980; Bradley et al. 2004b; Edwards and Bradley 2002; Reeder and Bradley 2004, in press a and b). *Adh1-12* supported a diphyletic origin for *Oryzomys*, a relationship also supported by *Cyt-b* and recent studies of nuclear markers (Myers and Tucker 1995; Smith and Patton 1993; Weksler 2003).

It is particularly noteworthy that, compared with *Cyt-b*, the *Adh1-12* dataset provided supported resolution to more species-level relationships within *Neotoma*, *Peromyscus*, and *Oryzomys* (Fig. 3), despite fewer overall characters (489 *Adh1-12*, 1,143 *Cyt-b*) and fewer parsimony informative characters (126 *Adh1-12*, 464 *Cyt-b*). Furthermore, all but one of the species-level relationships were congruent with results from *Cyt-b*. The exception involved the sister species relationships of *N. albigula*, *N. leucodon*, and *N. micropus*, and perhaps represented a situation of misleading phylogenetic inference. Whereas *Adh1-12* analysis provided strong support for a sister relationship between *N. albigula*

and *N. leucodon* (parsimony, 98%; maximum likelihood, 94%; Bayesian, 100%), *Cyt-b* analysis strongly supported a sister relationship between *N. leucodon* and *N. micropus* (parsimony, 86%; Bayesian, 100%). The difference, however, is that *Adh1-12* support was based on three characters, whereas *Cyt-b* support was based on 22 characters. We view these particular *Adh1-12* results with caution, and suggest additional study of nuclear markers will be necessary to help determine whether *Adh1-12* results accurately reflect a conflict between the mitochondrial and nuclear genomes or represents the case of misleading inference of relationship due to inadequate variability.

Overall, the *Adh1-12* results are congruent with results from *Cyt-b* and other types of data, and generally are accompanied by high statistical support. Furthermore, multiple sequence alignment, which can be problematic with non-coding DNA sequences (Giribet and Wheeler 1999; Hooper and Van Den Bussche 2003; Van Den Bussche et al. 2002), was not of particular concern in this study. Although we identified 125 ambiguously aligned characters in the 5:4 alignment and 133 in the 30:5 alignment, results from analysis of both alignments with and without the ambiguous characters were identical in topology and statistical support. Thus, most of the phylogenetic signal in the *Adh1-12* dataset was associated with polymorphisms (nucleotide substitutions) rather than insertions/deletions. Yet, some insertion/deletions were informative. For example, a 5 bp (nucleotide positions 335-339) and a 4 bp (nucleotide positions 487-490) insertion/deletion were present in species of *Oryzomys* and *Holochilus* but absent in *Neotoma* and *Peromyscus*. Similarly, a 17

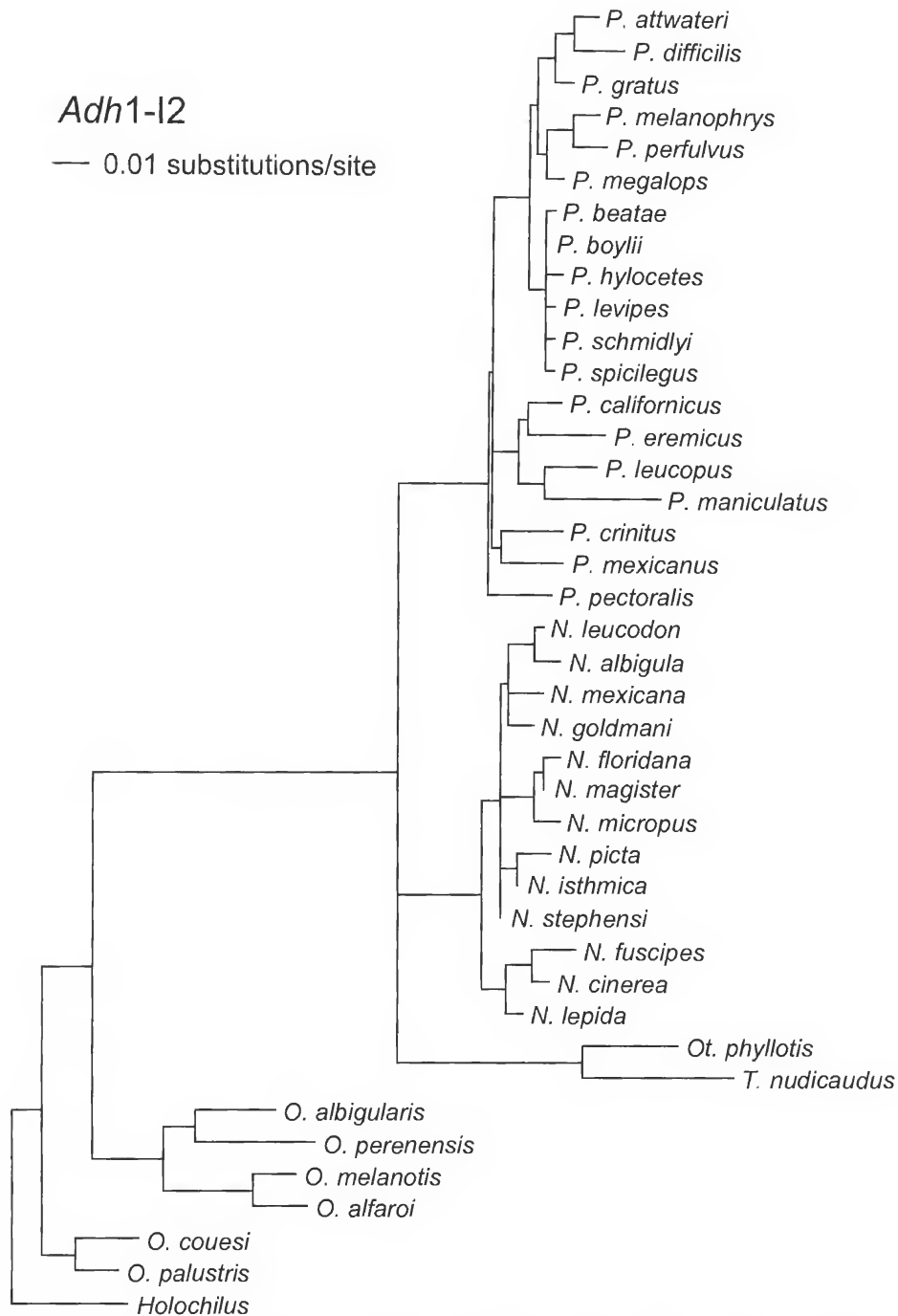

Figure 1. Maximum likelihood phylogram (LnI -2,718.627) from analysis of 5:4 gap cost-ratio alignment of complete *Adh1-12* sequences (489 base pairs; 614 aligned sites minus 125 ambiguously aligned sites) using best-fit model (HKY + G; $t_i/t_v = 2.308$, $\pi_A = 0.301$, $\pi_C = 0.191$, $\pi_G = 0.183$, $\pi_T = 0.325$, $\alpha = 1.662$). *Holochilus* was the designated outgroup. *N.* = *Neotoma*. *O.* = *Oryzomys*. *Ot.* = *Otodylomys*. *P.* = *Peromyscus*. *T.* = *Tylomys*.

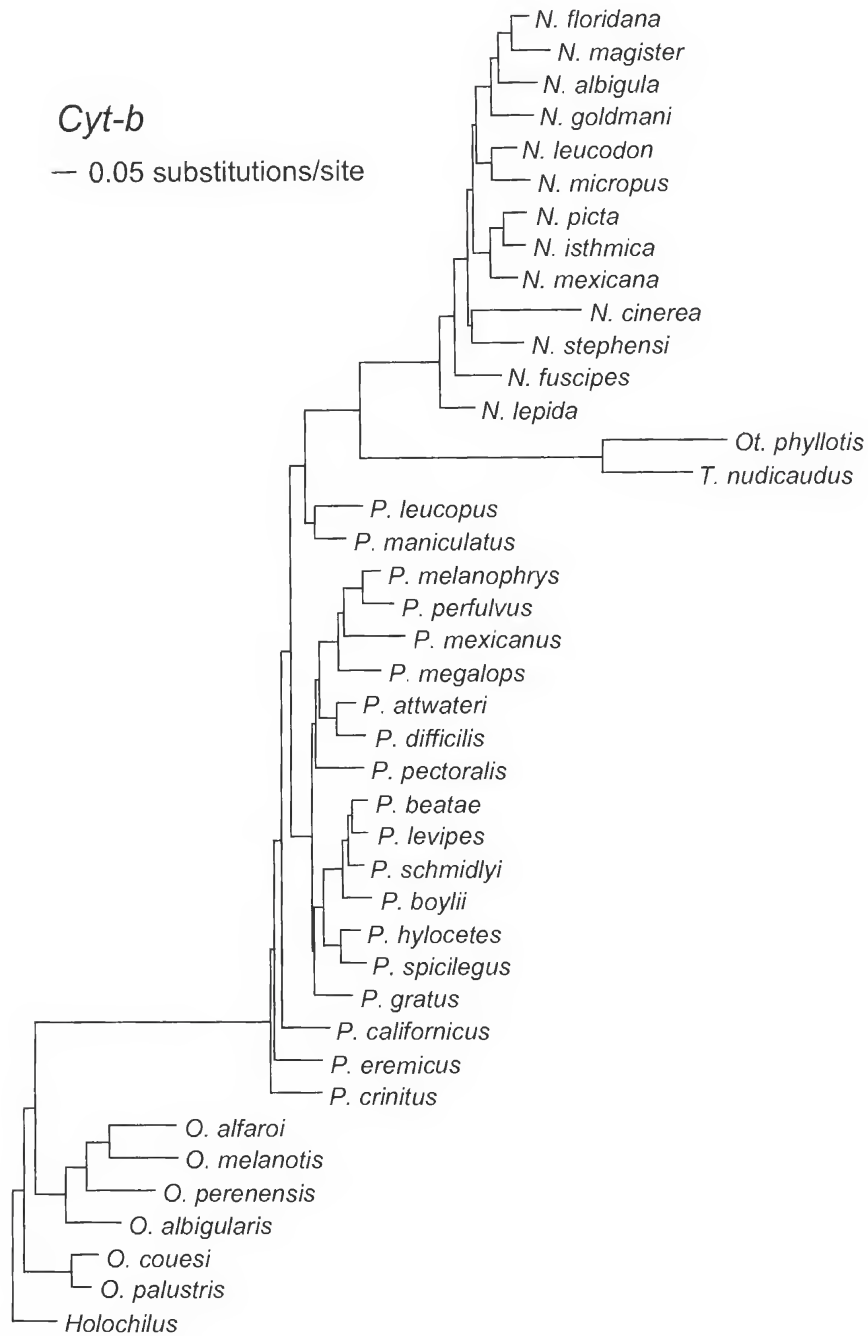

Figure 2. Maximum likelihood phylogram (LnL -14,379.922) from analysis of complete *Cyt-b* sequences (1,143 base pairs) using best-fit model (GTR + G + I; $R_{AC} = 1.310$, $R_{AG} = 10.479$, $R_{AI} = 2.473$, $R_{CG} = 0.708$, $R_{CT} = 32.137$, $\pi_A = 0.375$, $\pi_C = 0.343$, $\pi_G = 0.079$, $\pi_T = 0.203$, $\alpha = 0.687$, $p_{mv} = 0.456$). *Holochilus* was the designated outgroup. *N.* = *Neotoma*. *O.* = *Oryzomys*. *Ot.* = *Ototylomys*. *P.* = *Peromyscus*. *T.* = *Tylomys*.

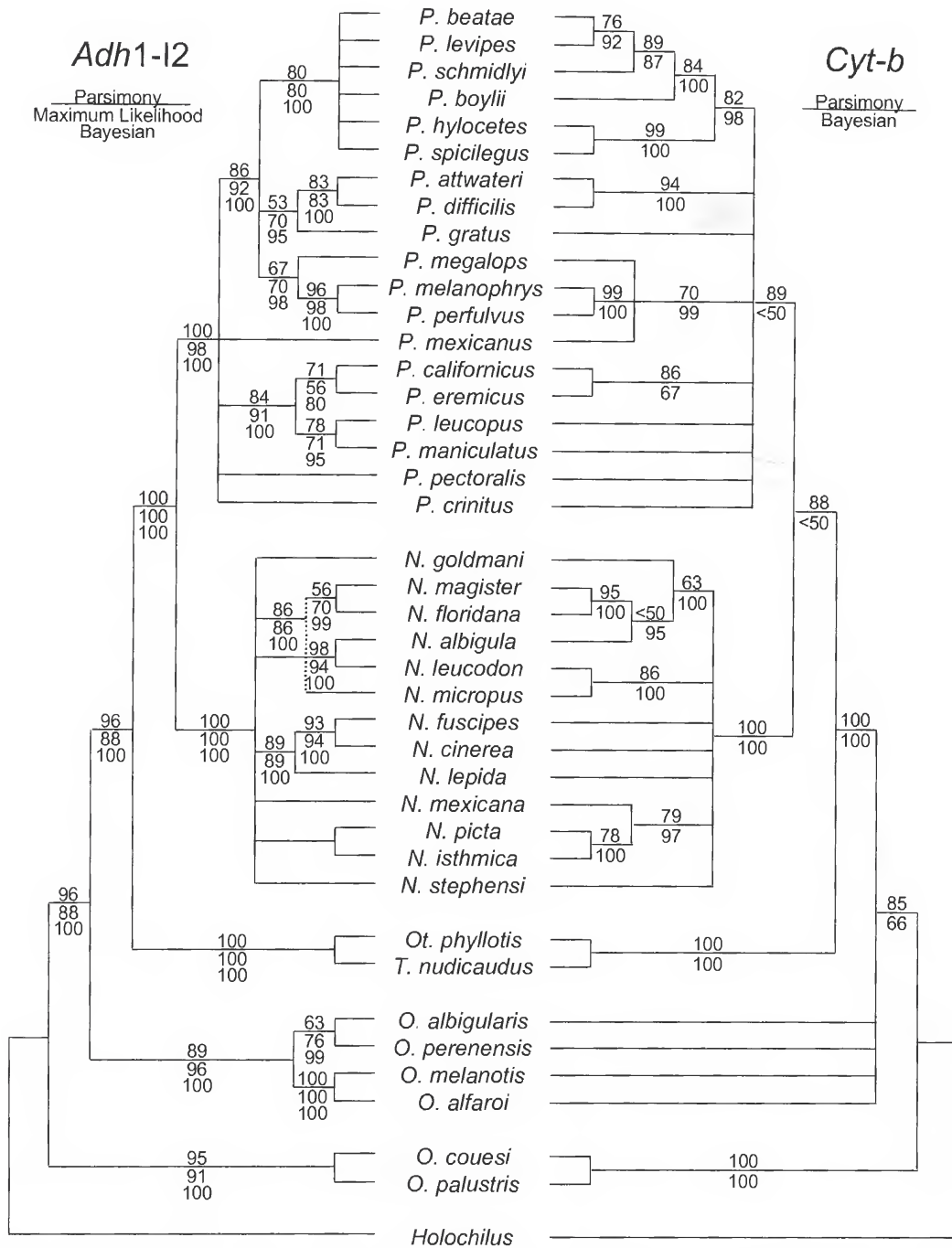

Figure 3. Cladograms from phylogenetic analyses of complete *Adh1-12* (left) and *Cyt-b* (right) DNA sequences. *Holochilus* was the designated outgroup. In order, numbers above and below nodes are bootstrap proportions (250 iterations) from parsimony analysis, bootstrap proportions (100 iterations) from maximum likelihood analysis, and posterior probability proportions (100 iterations) from Bayesian analysis. Maximum likelihood bootstrapping was feasible only for *Adh1-12* data. Only nodes with $\geq 70\%$ bootstrap support or ≥ 0.95 posterior probabilities, or both, are shown. Vertical dotted line indicates sister relationship between *N. micropus* and clade of *N. floridana* + *N. magister*. *N.* = *Neotoma*. *O.* = *Oryzomys*. *Ot.* = *Ototylomys*. *P.* = *Peromyscus*. *T.* = *Tylomys*.

bp insertion/deletion (nucleotide positions 502-518) was present in *Neotoma* and *Peromyscus* but was absent in *Oryzomys* and *Holochilus*. These results are encouraging toward the goal of recovering reliable phylogenetic relationships at low and intermediate

taxonomic levels from a nuclear intron. Further study of this intron, along with other nuclear and mitochondrial markers, should aid our understanding of the phyletic limitations of *Adh1-12* as well as organismal genealogy.

ACKNOWLEDGMENTS

Thanks to B. Dnaté Baxter, Nevin D. Durish, Michelle L. Haynie, Dallas D. Henson, Lindsey D. Porr, Andrew O. Stallings, Ryan R. Chambers, and two anonymous reviewers for providing helpful comments on previous versions of this manuscript. Thanks to

Robert J. Baker for use of laboratory equipment and computers during various stages of this study. This research was supported by a grant from the National Institutes of Health (DHHS A141435-01 to RDB).

LITERATURE CITED

- Anderson, S., A. T. Bankier, B. G. Barrell, M. H. de Bruijn, A. R. Coulson, J. Drouin, I. C. Eperon, D. P. Nierlicj, B. A. Roe, F. Sanger, P. H. Schreier, A. J. Smith, R. Staden, and I. G. Young. 1981. Sequence and organization of the human mitochondrial genome. *Nature* 290:457-465.
- Avise, J. C. 1994. Molecular markers, natural history, and evolution. Chapman and Hall, New York.
- Ballard, J. W., B. Chernoff, and J. C. Avise. 2002. Divergence of mitochondrial DNA is not corroborated by nuclear DNA, morphology, or behavior in *Drosophila simulans*. *Evolution* 56:527-545.
- Bradley, R. D., J. J. Bull, A. D. Johnson, and D. M. Hillis. 1993. Origin of a novel allele in a mammalian hybrid zone. *Proceedings National Academy of Science* 90:8939-8941.
- Bradley, R. D., R. M. Adkins, R. L. Honeycutt, and J. H. McDonald. 1998. Nucleotide polymorphism at the alcohol dehydrogenase locus of pocket gophers, genus *Geomys*. *Molecular Biology and Evolution* 15:709-717.
- Bradley, R. D., D. S. Carroll, M. L. Haynie, R. Muñoz-Martínez, M. J. Hamilton, and C. W. Kilpatrick. 2004a. A new species of *Peromyscus* from western Mexico. *Journal of Mammalogy* 85:1184-1193.
- Bradley, R. D., C. W. Edwards, D. S. Carroll, and C. W. Kilpatrick. 2004b. Phylogenetic relationships of Neotomine-Peromyscine rodents: based on DNA sequences from the mitochondrial cytochrome *b* gene. *Journal of Mammalogy* 85:389-395.
- Carleton, M. D. 1980. Phylogenetic relationships in neotomine-peromyscine rodents (Muridae) and a reappraisal of the dichotomy within New World cricetinae. Miscellaneous Publications, Museum of Zoology, University of Michigan 157:1-146.
- Carroll, D. S., and R. D. Bradley. 2005. Systematics of the genus *Sigmodon*: DNA sequences from beta-fibrinogen and cytochrome-*b*. *The Southwestern Naturalist* 50:342-349.
- Collins, T., P. H. Wimberger, and G. J. P. Naylor. 1994. Compositional bias, character-state bias, and character-state reconstruction using parsimony. *Systematic Biology* 43:482-496.
- Crabb, D. W., and H. J. Edenberg. 1986. Complete amino acid sequence of rat liver alcohol dehydrogenase deduced from the cDNA sequences. *Gene* 48:287-292.
- Crabb, D. W., P. M. Stein, K. M. Dipple, R. Sidhu, K. Zhang, and H. J. Edenberg. 1989. Structure and expression of the Rat Class I alcohol dehydrogenase gene. *Genomics* 5:906-914.
- DeSalle, R., C. Wray, and R. Absher. 1994. Computational problems in molecular systematics. Pp. 353-370 in *Molecular ecology and evolutions: Approaches and applications* (B. Schierwater, B. Streit, G. P. Wagner, and R. DeSalle, eds.). Birkhäuser Verlag Basel, Switzerland.
- Desjardins, P., and R. Morais. 1990. Sequence and gene organization of chicken mitochondrial genome. *Journal of Molecular Biology* 212:599-634.

- Dolney, D. E. A., G. Szalai, G. Duester, and M. R. Felder. 2001. Molecular analysis of genetic differences among inbred mouse strains controlling tissue expression pattern of alcohol dehydrogenase 4. *Gene* 267:145-156.
- Duester, G., J. Farrés, M. R. Felder, R. S. Holmes, J. Höög, X. Parés, B. V. Plapp, S. Yin, and H. Jörnvall. 1999. Recommended nomenclature for the vertebrate alcohol dehydrogenase gene family. *Biochemical Pharmacology* 58:389-395.
- Edwards, C. W. and R. D. Bradley. 2002. Molecular systematics of the genus *Neotoma*. *Molecular Phylogenetics and Evolution* 25:489-500.
- Felsenstein, J. 1985. Confidence limits on phylogenies: An approach using the bootstrap. *Evolution* 39:783-791.
- Fonseca, R.M., S.R. Hooper, C.A. Cline, D.A. Parish, F.G. Hoffmann, C.A. Porter, and R.J. Baker. In press. Comments on the morphological variation in dark-bellied species of *Micronycteris* (Phyllostomidae: Micronycterinae), with description of a new species from northwestern Ecuador. Pp. xxx-xxxx in *The quintessential naturalist: honoring the life and legacy of Oliver P. Pearson* (D.A. Kelt, E. Lessa, J.A. Salazar-Bravo, and J.L. Patton, eds.). University of California Press.
- Giribet, G., and W. C. Wheeler. 1999. On gaps. *Molecular Phylogenetics and Evolution* 13:132-143.
- Gouy, M., and W.-H. Li. 1989. Phylogenetic analysis based on rRNA sequences supports the archaeobacterial rather than the eocyte tree. *Nature* 339:145-147.
- Hafner, M. S., W. L. Gannon, J. Salazar-Bravo, and S. T. Alvarez-Castañeda. 1997. *Mammal collections in the western hemisphere: a survey and directory of existing collections*. Allen Press, Lawrence, Kansas.
- Helbig, A. J., A. Kocum, I. Seibold, and M. J. Braun. 2005. A multi-gene phylogeny of aquiline eagles (Aves: Accipitriformes) reveals extensive paraphyly at the genus level. *Molecular Phylogenetics and Evolution* 35:147-164.
- Hickson, R. E., C. Simon, and S. W. Perrey. 2000. The performance of several multiple-sequence alignment programs in relation to secondary-structure features for an rRNA sequence. *Molecular Biology and Evolution* 17:530-539.
- Hillis, D. M., C. Moritz, and B. K. Mable. 1996. *Molecular systematics* (D. M. Hillis, C. Moritz and B. K. Mable, eds.) Second edition. Sinauer and Associates, Sunderland, Massachusetts.
- Hillis, D. M., and J. P. Huelsenbeck. 1992. Signal, noise, and reliability in molecular phylogenetic analyses. *Journal of Heredity* 83:189-195.
- Hooper, S. R., and R. A. Van Den Bussche. 2003. Molecular phylogenetics of the chiropteran family Vespertilionidae. *Acta Chiropterologica* 5 (supplement):1-63.
- Huelsenbeck, J. P., and F. Ronquist. 2001. Mr.Bayes: Bayesian inference of phylogeny. *Bioinformatics* 17:754-755.
- Huelsenbeck, J. P., B. Larget, R. E. Miller, and F. Ronquist. 2002. Potential applications and pitfalls of Bayesian inference of phylogeny. *Systematic Biology* 51:673-688.
- Ikuta, E., S. Szeto, and A. Yoshida. 1986. Three human alcohol dehydrogenase subunits: cDNA structure and molecular and evolutionary divergence. *Proceedings of the National Academy of Sciences* 83:634-638.
- Jackson, P. D., and F. M. Hoffmann. 1994. Embryonic expression patterns of the *Drosophila* decapentaplegic gene: separate regulatory elements control blastoderm expression and lateral ectodermal expression. *Developmental Dynamics* 199:28-44.
- Johansson, U. S., and P. G. P. Ericson. 2004. A re-evaluation of basal phylogenetic relationships within trogons (Aves: Trogonidae) based on nuclear DNA sequences. *Journal of Zoological Systematics and Evolutionary Research* 43:166-173.
- Lavoué, S., J. P. Sullivan, and C. D. Hopkins. 2003. Phylogenetic utility of the first two introns of the S7 ribosomal protein gene in African electric fishes (Mormyroidea: Teleostei) and congruence with other molecular markers. *Biological Journal of the Linnean Society* 78:273-292.
- Leaché, A. D., and T. W. Reeder. 2002. Molecular systematics of the eastern fence lizard (*Sceloporus undulatus*): a comparison of parsimony, likelihood, and Bayesian approaches. *Systematic Biology* 51:44-68.
- Lockhart, P. J., M. A. Steel, M. D. Hendy, and D. Penny. 1994. Recovering evolutionary trees under a more realistic model of sequence evolution. *Molecular Biology and Evolution* 11:605-612.
- Lutzoni, F., P. Wagner, V. Reeb, and S. Zoller. 2000. Integrating ambiguously aligned regions of DNA sequences in phylogenetic analyses without violating positional homology. *Systematic Biology* 49:628-651.

- Maddison, D. R., and W. P. Maddison. 2002. MacClade 4 (version 4.05). Sinauer Associates, Sunderland, Massachusetts.
- Musser, G. G., and M. D. Carleton. 2005. Superfamily Muroidea. Pp. 894-1531 in *Mammal species of the world: a taxonomic and geographic reference*. Third edition (D. E. Wilson and D. M. Reeder, eds.). The Johns Hopkins University Press, Baltimore, Maryland. 2 vols.
- Myers, P., B. Lundrigan, and P. K. Tucker. 1995. Molecular phylogenetics of oryzomyine rodents: the genus *Oligoryzomys*. *Molecular Phylogenetics and Evolution* 4:372-382.
- Oakley, T. H., and R. B. Phillips. 1999. Phylogeny of salmonine fishes based on growth hormone introns: Atlantic (*Salmo*) and Pacific (*Oncorhynchus*) salmon are not sister taxa. *Molecular Phylogenetics and Evolution* 11:381-393.
- Park, D. H., and B. V. Plapp. 1991. Isoenzymes of horse liver alcohol dehydrogenase active on ethanol and steroids. cDNA cloning, expression, and comparison of active sites. *Journal of Biological Chemistry* 266:13296-13302.
- Perasso, R., A. Baroin, L.H. Qu, J. Bachelierie, and A. Adoutte. 1989. Origin of the algae. *Nature* 339:142-144.
- Perna, N. T., and T. Kocher. 1995. Unequal base frequencies and estimation of substitution rates. *Molecular Biology and Evolution* 12:359-361.
- Porter, C. A., S. R. Hofer, C. A. Cline, F. G. Hoffmann, and R. J. Baker. In review. Molecular phylogenetics of the genus *Micronycteris* (Phyllostomidae: Micronycterinae) with description of 2 new subgenera. *Journal of Mammalogy*.
- Posada, D. and K. A. Crandall. 1998. MODELTEST: testing the model of DNA substitution. *Bioinformatics* 14:817-818.
- Prychitko, T. M., and W. S. Moore. 1997. The utility of DNA sequences of an intron from the beta-fibrinogen gene in phylogenetic analysis of woodpeckers (Aves: Picidae). *Molecular Phylogenetics and Evolution* 8:193-204.
- Prychitko, T. M., and W. S. Moore. 2000. Comparative evolution of the mitochondrial cytochrome *b* gene and nuclear b-fibrinogen intron 7 in woodpeckers. *Molecular Biology and Evolution* 17:1101-1111.
- Reeder, S. A., and R. D. Bradley. 2004. Molecular Systematics of Neotomine-Peromyscine Rodents Based on the dentin matrix protein 1 gene. *Journal of Mammalogy* 85:1194-1200.
- Reeder, S. A., and R. D. Bradley. In Press a. Phylogenetic relationships of Neotomine-Peromyscine rodents using DNA sequences from intron 7 of the beta fibrinogen gene. Pp. xxx-xxx in *The quintessential naturalist: honoring the life and legacy of Oliver P. Pearson* (D. A. Kelt, E. Lessa, J. L. Patton, and J. A. Salazar-Bravo eds.). University of California Publications in Zoology.
- Reeder, S. A., C. W. Edwards, D. S. Carroll, and R. D. Bradley. In Press b. Neotomine-Peromyscine rodent systematics based on combined analyses of nuclear and mitochondrial DNA sequences. *Molecular Phylogenetics and Evolution*.
- Roe, B. A., D.-P. Ma, R. K. Wilson, and J. F.-H. Wong. 1985. The complete nucleotide sequence of the *Xenopus laevis* mitochondrial genome. *Journal of Biological Chemistry* 260:9759-9774.
- Saiki, R. K., D. H. Gelfand, S. Stoffel, S. J. Scharf, R. Higuchi, G. T. Horn, K. B. Mullis, and H. A. Erlich. 1988. Primer-directed enzymatic amplification of DNA with a thermostable DNA polymerase. *Science* 239:487-491.
- Slade, R. W., C. Moritz, and A. Heideman. 1994. Multiple nuclear-gene phylogenies: applications to pinnipeds and comparisons with a mitochondrial DNA gene phylogeny. *Molecular Biology and Evolution* 11:341-356.
- Smith, M. F., J. L. Patton. 1993. The diversification of South American murid rodents: evidence from mitochondrial DNA sequence data for the akodontine tribe. *Biological Journal of the Linnean Society* 50:149-177.
- Smith, M. F., and J. L. Patton. 1999. Phylogenetic relationships and the radiation of sigmodontine rodents in South America: evidence from cytochrome *b*. *Journal of Mammalian Evolution* 6:89-128.
- Swofford, D. L. 2002. PAUP*: phylogenetic analysis using parsimony (*and other methods) version 4.0b10. Sinauer Associates, Sunderland, Massachusetts.
- Szalai, G., G. Dueter, R. Friedman, H. Jia, S. Lin, B. A. Roe, and M. R. Felder. 2002. Organizations of six functional mouse alcohol dehydrogenase genes on two overlapping bacterial artificial chromosomes. *European Journal of Biochemistry* 269:224-232.
- Thompson, J. D., T. J. Gibson, F. Plewniak, F. Jean-mougin, and D. G. Higgins. 1997. The Clustal X window interface: flexible strategies for multiple sequence alignment aided by quality analysis tools. *Nucleic Acids Research* 25:4876-4882.

- Van Den Bussche, R. A., and S. R. Hooper. 2001. Evaluating monophyly of Nataloidea (Chiroptera) with mitochondrial DNA sequences. *Journal of Mammalogy* 82:320-327.
- Van Den Bussche, R. A., S. R. Hooper, and E. W. Hansen. 2002. Characterization and phylogenetic utility of the mammalian protamine P1 gene. *Molecular Phylogenetics and Evolution* 22:333-341.
- Weksler, M. 2003. Phylogeny of neotropical oryzomyine rodents (Muridae: Sigmodontinae) based on the nuclear IRBP exon. *Molecular Phylogeny and Evolution* 29:331-349.
- Wheeler, W. C. 1995. Sequence alignment, parameter sensitivity, and the phylogenetic analysis of molecular data. *Systematic Biology* 44:321-331.
- Wickliffe, J. K., F. G. Hoffmann, D. S. Carroll, Y. V. Dunina-Barkovskaya, R. D. Bradley, and R. J. Baker. 2003. Intron 7(Fgb-17) of the fibrinogen, B beta polypeptide (Fgb): a nuclear DNA phylogenetic marker for mammals. *Occasional Papers, Museum of Texas Tech University* 219:i+1-6.
- Zhang, K., W. F. Bosron, and H. J. Edenberg. 1987. Structure of the mouse *Adh-1* gene and identification of a deletion in a long alternating purine-pyrimidine sequence in the first intron of strains expressing low alcohol dehydrogenase activity. *Gene* 57:27-36.
- Zheng, Y.-W., M. Bey, H. Liuand, and M. R. Felder. 1993. Molecular basis of the alcohol dehydrogenase-negative deer mouse. *Journal of Biological Chemistry* 268:24933-24939.

Addresses of authors:

Addresses for Brian R. Amman, J. Delton Hanson, Lisa K. Longhofer, Steven R. Hooper, and Robert D. Bradley:

*Department of Biological Sciences
Texas Tech University
Lubbock, Texas 79409-3131
BRA e-mail: bamman@cdc.gov
JDH e-mail: jdelton.hanson@ttu.edu
LKL e-mail: brombe14@hotmail.com
SRH e-mail: srhooper@hotmail.com
RDB e-mail: robert.bradley@ttu.edu*

Current Address for Brian R. Amman:
*Centers for Disease Control and Prevention
Division of Viral and Rickettsial Diseases
Special Pathogens Branch
Atlanta, GA 30333*

Current Address for Lisa K. Longhofer:
*Texas Tech University Health Sciences Center
Texas Tech University
Lubbock, Texas 79409*

Address for Robert D. Bradley:
*Department of Biological Sciences and
Museum of Texas Tech University
Lubbock, Texas 79409-3191*

APPENDIX I

Specimens examined.— Collection localities, museum acronyms, and GenBank accession numbers are provided for each specimen examined in this study. Specimens are from the United States unless otherwise noted. Abbreviations for museum acronyms (in parentheses and to the left of the semicolon) follow Hafner et al. (1997): Abilene Christian University Natural History Collection (ACUNHC), Angelo State University Museum Natural History Collections (ASNHC), Monte L. Bean Life Science Museum (BYU), Texas Cooperative Wildlife Collection (TCWC), Museum of Texas Tech University (TTU), The Museum of Southwestern Biology (MSB), and Universidad Nacional Autónoma de México (UNAM). If museum catalogue numbers were unavailable, specimens were referenced with the corresponding TK number (special number of the Museum of Texas Tech University). GenBank accession numbers (AF, AY, U, and DQ) for *Adh1-12* and *Cyt-b* are provided in parentheses to the right of the semicolon and separated by a comma, respectively.

Holochilus chacarius.—PARAGUAY: Departamento Pte. Hayes; Estancia Loma Pora, 23°33.15'S, 57°34.3'W (TTU104423; DQ227456, DQ227455).

Neotoma albigula.—New Mexico; Yuma Co., 3.7 km S, 5.6 km W Somerton, UTM 11 708569E 3608362N (TTU78451; AY817648, AF376477).

Neotoma cinerea.—Utah; San Juan Co., Owaehamo Bridge (MSB121427; AY817635, AF186799).

Neotoma floridana.—South Carolina; Richland Co.. Congaree Swamp National Monument, 33°49'N, 80°50'W (MSB74955; AY817637, AF294335).

Neotoma fuscipes.—California; Riverside Co., Rancho Capistrano (Ortega Mountains) (TTU81391; AY817632, AF376479).

Neotoma goldmani.—MEXICO: Nuevo Leon; 1 km S Providencia (TTU45227; AY817656, AF186829).

Neotoma isthmica.— MEXICO: Oaxaca; Las Minas, UTM 15 191165E 1824954N (TTU82665; AY817630, AF329079).

Neotoma lepida.—California; Orange Co., Irvine Lake, 1.3 km E Fremont Canyon on Lake View access road (TTU79131; AY817633, AF307835).

Neotoma leucodon.—Texas; Kerr Co., Kerr Wildlife Management Area, UTM 14 452336E 3330772N (TTU71198; AY817643, AF186806).

Neotoma magister.—Virginia; Madison Co., Shenendoah National Park, White Oak Canyon, 38°34'36"N, 78°22'30"W (MSB74952; AY817641, AF294336).

Neotoma mexicana.— Texas; Jeff Davis Co., Mount Livermore Preserve, UTM 13 579953E 3389871N (TTU101643; AY817645, AF294346).

Neotoma micropus.—New Mexico; Roosevelt Co., 26.4 km S, 4.8 km E Taiban (TTU catalogue number unavailable, TK31643; AY817652, AF186822).

Neotoma picta.—MEXICO: Guerrero; 6.4 km SSW Filo de Caballo (UNAM catalogue number unavailable, TK93390; AY817629, AF305569).

Neotoma stephensi.—Arizona; Navaho Co., 4.8 km S Woodruff, UTM 12 588361E 3844338N (TTU78505; AY817642, AF308867).

Oryzomys albigularis.—ECUADOR: Pichincha; 10 km NW Quito, Tandayapa Valley, 0°00'13"N, 78°40'70"W (ACUNHC917; DQ207945, DQ224407).

Oryzomys alfaroi.—NICARAGUA: Selava Negra; Altajo Trail (TTU101644; DQ207950, DQ224410).

Appendix 1 (cont.)

Oryzomys cousei.—HONDURAS: Olancho; 4 km E Catacamas (Escuela de Sembrador), UTM 16 624523E 1637511N (TTU84697; DQ207948, DQ185383).

Oryzomys melanotis.—HONDURAS: Atlantida; Lancetilla Botanical Gardens, UTM 16 451012E 1740282N (TTU84374; DQ207947, DQ224409).

Oryzomys palustris.—Texas; Galveston Co., Texas City, Virginia Point (TTU82920; DQ207949, DQ185382).

Oryzomys perenensis.—PERU: Loreto; Maynas, 25 km S Iquitos (Estacio Biologia Allpahuayo) (TTU98606; DQ207946, DQ224408).

Oryzomys phyllotis.—HONDURAS: Atlantida; Lancetilla Botanical Gardens, UTM 16 451012E 1740282N (TTU84371; AY817624, no *Cyt-b* data); MEXICO: Quintana Roo, 1 km N Noh-bec (ASNHC7254; no *Adh1*-I2 data, AY009788).

Peromyscus attwateri.—Oklahoma; McIntosh Co., 5 km E Dustin (TTU55688; AY817626, AF155384).

Peromyscus beatae.—MEXICO: Chiapas, Yalentay, UTM 15 524171E 1852486N (UNAM catalogue number unavailable, TK93279; AY994223, no *Cyt-b* data); Veracruz; Xometla (TCWC48060; no *Adh1*-I2 data, AF131921).

Peromyscus boylii.—California; San Diego Co., Heise County Park (TTU83102; AY994225, no *Cyt-b* data); MEXICO: Aguascalientes; Rincon de Romos (TCWC48438; no *Adh1*-I2 data, AF131924).

Peromyscus californicus.—California; Los Angeles Co., Chatsworth Reservoir Park (TTU83292; AY994211, AF155393).

Peromyscus crinitus.—Utah; Emery Co., Cottonwood Canyon, 39°16'51.8"N, 111°10'31.9"W (BYU18639; AY994213, AY376413).

Peromyscus difficilis.—MEXICO: Tlaxcala; 2 km NE Tepetitla (TTU82690; AY994219, AY376416).

Peromyscus eremicus.—California: Los Angeles Co., Kanan Dome Road (TTU81850; AY994212, no *Cyt-b* data); California: Los Angeles Co., Calabasas Creekside Park (TTU83249; no *Adh1*-I2, AY322503).

Peromyscus gratus.—MEXICO: Michoacán; 4 km E Costzeo (UNAM catalogue number unavailable, TK46354; AY994218, AY376421).

Peromyscus hylocetes.—MEXICO: Michoacán; Estacion Cerra Burror, Microodas; 3,270 m (UNAM catalogue number unavailable, TK 45309; AY994235, DQ000481).

Peromyscus leucopus.—Texas; Presidio Co., Las Palomas Wildlife Management Area, UTM 13 529481E 3321292N (TTU75694; AY994240, no *Cyt-b* data); Dickens Co., 0.9 km E Afton (TTU catalogue number unavailable, TK47506; no *Adh1*-I2 data, AF131926).

Peromyscus levipes.—MEXICO: Michoacán, Las Minas, 3 km SW Tuxpan (UNAM catalogue number unavailable, TK47819; AY994224, DQ000477).

Peromyscus maniculatus.—Arkansas; Mississippi Co., Dillahunty Pecan Orchard (TTU97830; AY994242, no *Cyt-b* data); Alaska, Alexander Archipelago, Bushy Island, Petersburg Quad, 56°15'45"N, 132°58'52"W (UAM50770; no *Adh1*-I2 data, AF119261).

Peromyscus megalops.—MEXICO: Guerrero; 6.4 km SSW Filo de Caballo (TTU82712; AY994217, DQ000475).

Peromyscus melanophrys.—MEXICO: Durango; 2.2 km S, 2.5 km E Vicente Guerrero (TTU75509; AY994216, AY322510).

Peromyscus mexicanus.—MEXICO: Chiapas; 14.4 km N Ocozocoaulta (TTU82759; AY994236, AY376425).

Appendix 1 (cont.)

Peromyscus pectoralis.—MEXICO: Jalisco; 30 km W Huejuquilla del Alto (UNAM catalogue number unavailable, TK48645; AY994221, no *Cyt-b* data; TTU75575; no *Adh1-12* data, DQ000476).

Peromyscus perfulvus.—MEXICO: Michoacán; Tunel de Riego, 2 km E Cerro Colorado, 1290 M, 19°19'220"N, 100°28'308"W (UNAM catalogue number unavailable, TK47926; AY994215, DQ000474).

Peromyscus schmidlyi.—MEXICO: Durango; 6.1 km W Coyotes, Hacienda Coyotes, UTM 13 465908E 2634281N (TTU81617; AY994228, AY322524).

Peromyscus spicilegus.—MEXICO: Michoacán; KM 81 carr., Ario de Rosales-La Huacana, 1602 m, 19°10'59"N, 101°43'42"W (UNAM catalogue number unavailable, TK 47888; AY994232, DQ000480).

Tylomys nudicaudatus.—GUATEMALA: Izabal, Cerro San Gil (TTU62082; AY817625, AF307839).



TEXAS TECH UNIVERSITY

Natural Science Research Laboratory

PUBLICATIONS OF THE MUSEUM OF TEXAS TECH UNIVERSITY

Institutional subscriptions are available through the Museum of Texas Tech University, attn: NSRL Publications Secretary, Box 43191, Lubbock, TX 79409-3191. Individuals may also purchase separate numbers of the Occasional Papers directly from the Museum of Texas Tech University.



ISSN 0149-175X

Museum of Texas Tech University, Lubbock, TX 79409-3191