

LIBRARY OF
THE NEW YORK BOTANICAL GARDEN

By exchange

September 1899

W. Gibson. Inv.

NEW YORK BOTANICAL GARDEN

Journal of Applied Microscopy

VOLUME I

JANUARY TO DECEMBER

1898

ROCHESTER, N. Y.:

Published by the Publication Department Bausch & Lomb Optical Co.

INDEX.

- Aberration, Spherical, Caused by Variations of Tube Length, and Thickness of Cover-glass, 6.
- Abstracts, 34, 58, 95, 114, 153, 220.
- Achromatic Doublets and Triplets, Construction of, 115.
- Acid Alcohol, formula for, 104.
- Acid Magenta, test for, 61.
- Acid or Protoplasmic Stains, 102.
- Actinomycosis, 178.
- Acute Vision, A Method of Preserving the Eye for Sectioning, or for Demonstrating the Area of, 18.
- Adulterants in Powdered Drugs, the Use of the Microscope in the Detection of, 119.
- Adulteration of Wheat Flour with Maize Products, a Note on the Quantitative Determination of, 122.
- Adventurine Glass, Copper Crystals in, 95.
- Agar-Agar, The Preservation of Culture Media, 106.
- Agar, or Gelatin, Method for Filtering, 201.
- Agar, Preparation of, 8, 62.
- Agents for Clearing, 104, 220.
- Air, Apparatus for Removing from Mounted Slides, and Material, 74.
- Albumen Fixative, 103.
- Alcohol as a Hardening Fluid, 40.
- Algae and Fungi, Filamentous, a Convenient Method for Mounting, 156.
- Algae, Cultivation of in Aquaria, 193.
- Algae Treated with Flemming's Fluid and Iron Haematoxylin, 156.
- Allium, Results from the Study of, 215.
- Alum-Carmine, Anthrax Bacilli Stained with, 175.
- Alum-Carmine and Picro-Carmine as Counter Stains, 174.
- Alyssum, the Embryology of, 215.
- American Laboratories, Representative, 23.
- American Microscopical Society: Programme for Twenty-first Annual Meeting, 147.
- Report of Twenty-first Annual Meeting, 161.
- American Postal Microscopical Club, 181.
- Ammonium Picrate for Fixing Methylene Blue, 66.
- Amyloid, Rose-Bengale Test for, 62.
- Anaemia, as Related to Megablasts, 218.
- Anaerobic Bacteria, a Simple Method for the Culture of, in Liquid Media, 34.
- Anatomical Atlas of Tschirch and Oesterle, 114-198.
- Angle, Proper, of Microtome Knife, 35.
- Anilin Dyes for Bacteria, 159.
- Anilin-Safranin for Staining Starch, 181.
- Antherozoids, Motile, Recent Investigations on, 182.
- Anthrax Bacilli, to Differentiate Nucleus and Cell Body, 175.
- Antiseptic Cotton, to Prepare, 73.
- Apogamy in *Balanophora Elongata*, 197.
- Apparatus:
- A Convenient Water Bath, 33.
 - A Makeshift Photo-Micrographic Apparatus, 77.
 - A New Filtering Apparatus, 9.
 - A New Thermo-Regulator, 91.
 - A Rapid Staining Apparatus, 169.
 - A Simple Steam Sterilizer, 33.
 - For Prolonged Washing of Tissue, 129.
 - For Removing Air from Mounted Slides and Material, 74.
- Apparatus, continued:
- Osmometer and Root-Pressure Apparatus, 56.
 - Thermo-Regulated Waterbaths for the Bacteriological Laboratory, 108.
 - To Facilitate the Counting of Colonies of Bacteria on Circular Plates, 53.
 - To Facilitate the Work of the Histological and Embryological Laboratory, 124.
 - Washing Apparatus for Histological Purposes, 200.
- Area of Acute Vision, Method of Preserving the Eye for Demonstrating the, 18.
- Aseptic Cultivation of Mycetozoa, 96.
- Asparagin Liquid Culture Medium for Bacteria, 35.
- Babcock Test for Milk, 210.
- Bacilli, Anthrax, Stained with Alum-Carmine, 175.
- Bacilli, Tubercle, Examination of Milk for, 14.
- Bacteria:
- Anaerobic, 34.
 - Anilin Dyes for, 159.
 - Apparatus to Facilitate the Counting of Bacteria on Circular Plates, 53.
 - Asparagin Liquid Culture Medium for, 35.
 - Colonies of Bacteria in Petri Dishes, A Scheme for Counting, when the Colonies are Small and very Numerous, 84.
 - Detection of Pathogenic Forms, 175.
 - Diagnosis and Descriptions of, 115.
 - Examination of, 157.
 - Fixing Agents for, 40, 211.
 - Fuchsin and Gentian Violet for Staining, 160.
 - Gram's Method of Staining, 190.
 - Isolation of, 153.
 - Persistence of in the Milk Ducts of the Cow's Udder, 205.
 - Relationships of, 183.
 - Staining of, 159.
 - To Stain in Sections, 211.
- Bacterial Spores, to Stain, 35, 191.
- Bacterial Stains, Formulae for, 192.
- Bacteriological Laboratory of Cornell University, 25.
- Bacteriological Laboratory, Thermo-Regulated Water Baths for, 108.
- Bacteriologists, Committee of American, 115.
- Bacteriology, Laboratory Methods in, 157, 175, 190, 211.
- Bacterium Cell, Is It Nucleated, 223.
- Balsam Bottle, Metal Cap for, 204.
- Becker's Rosanilin Nitrate for Demonstrating Early Amyloid, 62.
- Beiträge zur Kenntniss der weiblichen Blüthen und Inflorescenzen bei Cannabineen, 215.
- Beitrag zur Technik des Ausvoslebens von Celloidinschnitten, 218.
- Benzo-Purpurin 6 B, a Test for HCl, 62.
- Bethe's Fixing Fluid for Methylene Blue, 66.
- Biaxial Minerals, 20.
- Biological Faculty, University of Missouri, 186.
- Black Finish for Table Tops, 145.
- Black Haematoxylin, 197.
- Bleaching Insects with Peroxide of Hydrogen, 175.
- Blepharoplasts in Antherozoids, 182, 183.
- Blepharoplasten bei Onoclea und Marsilia, 183.
- Blood Cells, Counting of, 132.
- Blood, Human, Methods for the Microscopic Examination of, 132.

- Blood in the Capillaries, A Simple and Convenient Method for Demonstrating the Circulation of, 101.
- Blood, Nucleated, Method of Preparing, 187.
- Blood Preparations, Fixing of, 134.
- Blood Preparations, A Moist Chamber for, 128.
- Blood Preparations; to Obtain, Fix, Stain, 133.
- Blood, Solutions for Staining, 133.
- Blood Studies, Formalin as a Reagent for, 189.
- Blowfly, to Mount the Tongue of, 137.
- Boehmer's Haematoxylin Solution, 102.
- Book Reviews:
- Bokorny (Dr. Th.), *Lehrbuch der Botanik für Realschulen und Gymnasien*, 197.
 - Fish (Pierre A., D. Sc.), *Practical Exercises in Comparative Physiology and Urine Analysis*, 184.
 - French (G. H., A. M.), *A Manual of Dissection and Histology for Use in Classes in Physiology, in High Schools, Normal Schools, and Academies*, 184.
 - Jorgensen, *Micro-Organisms of Industrial Fermentation*, 116.
 - Koch (Alfred), *Jahresbericht ueber die Fortschritte in der Lehre von den Gahrungs-organismen*, 198.
 - Migula's System of Bacteria, 116.
 - Moore (Veranus A., B. S., M. D.), *Laboratory Directions for Beginners in Bacteriology*, 172.
 - Tauchnitz (Herm.), *Anatomischer Atlas der Pharmakognosie und Nahrungsmittelkunde*, 198.
 - Tschirch and Oesterle, *Anatomischer Atlas der Pharmakognosie und Nahrungsmittelkunde*, 114.
 - Underwood (W. Lyman), and Prescott (S. C.), *Micro-organisms and Sterilizing Processes in the Canning Industries*, 185.
- Botanical Laboratories of Cornell University, 25.
- Botanical Literature, Current, 182, 196, 215.
- Botanische Untersuchungen ueber die Wasserapparate der Gefaesspflanze, 216.
- Botany, Department of, Ohio State University, 188.
- Botany, Department of, University of Nebraska, Appointments, Summer Courses, 186.
- Buckwheat Flour, to Detect the Adulteration of, 229.
- Cabinet for Paraffin Sections, 109.
- Camera and Condensing System, Photo-Micrographic, New Form of, 117.
- Camera, A Practical Photo-Micrographic, 94.
- Can for Collecting with a Bicycle, 131.
- Carbolic Acid as a Clearing Agent, 152.
- Carbolic-Fuchsin, Zielh's Formula for, 178.
- Carcinoma of the Stomach, to Test for, 62.
- Carob, the Development, Structure and Chemistry of, 198.
- Cartilage Cells, Embryonic, Stains for, 174.
- Catalogue for Laboratory Supplies, 31.
- Cell Bridges, Injection Solution for Demonstrating, 201.
- Celloidin Imbedding, 71, 145.
- Celloidin Sections, Cutting of, 88.
- Celloidin Sections, Scheme for Staining, 104, 105.
- Celloidin, to Prepare, 71.
- Cell Problems, 200.
- Cell Wall, the, to Show the Nature of, 38.
- Centration of the Electric Arc in Photo-Micrography, 115.
- Centrifugal Milk Analysis, 209.
- Centrosome in Ganglion Cells, 219.
- Centrosome in Scyllium Canicula, 199.
- Centrosome, Question of Its Origin in Fertilization, 200.
- Centrosome, The, in Tetraspore Mother Cells of Dictyota Dichotoma, 197.
- Ceratonia siliqua, sur la graine et specialement sur l'endosperme du, 198.
- Chara fragilis, Habitat, Appearance, Rate of Motion of Protoplasm, 73.
- Chemotropic Stimuli for Plasmodia of Mycetozoa, 15.
- Chloriodide of Zinc for Staining Seeds, 38.
- Chromatophores of Cephalopodes, 199.
- Chromic-osmic-acetic Mixture, Flemming's 81, 196.
- Chromo-acetic acid, 156.
- Chromalpetersaure als Pigment Zersteoerendes Mittel, 217.
- Cilia in their Relation to the Centrosome, 200.
- Cilia, to Demonstrate the Motion of, 203.
- Circulation of Blood in the Capillaries, A Simple and Convenient Method for Demonstrating, 101.
- Classification Based on the Structure of the OvuLe, 198.
- Class Technique in Pathology, 9.
- Clay, Modeling, the Use of in the Study of the Fish Embryo, 146.
- Cleaning Old Slides, 149.
- Clearing Agent for Polyzoa, etc., CarboLic Acid, 152.
- Clearing Agents for Sections, 104.
- Clearing and Mounting Media, Refractive Index and Alcohol-Solvent Power of, 220.
- Clearing up Lantern Slides, 74.
- Coccidium Oviforme, 41.
- Collection and Habitat of Plasmodia and Sporangia, 1.
- Collection of Pond Life on Photographic Plates, 115.
- Collodion Imbedding, A Holder for, 55.
- Colonies of Bacteria in Petri Dishes when the Colonies are Small and Very Numerous. A Scheme for Counting, 84.
- Colonies of Bacteria on Circular Plates, An Apparatus to Facilitate the Counting of, 53.
- Colonometer, A New, 54.
- Combination of the Paraffin and Celloidin Methods of Imbedding, A, 67.
- Compass-Dial or Clock-Face, Points of, for Locating Objects Under the Microscope, 116.
- Congo Red, A Test for Free Acid, 62.
- Construction of Achromatic Doublets and Triplets, 115.
- Construction of a Tow Net, Hints on the, 111.
- Convenient Paraffin Imbedding Dish, 56.
- Convenient Water Bath, A, 33.
- Copper Crystals in Adventurine Glass, 95.
- Corks and Labels, 123.
- Cornell University, Representative American Laboratories, 23.
- Corpuscles, Red, to Bleach, 133.
- Corpuscles, Relative Size of, 185.
- Counter Staining with Eosin, and with Van Gieson's Stain, 102, 104.
- Counter Stains, Picro-Carmine and Alum-Carmine, 174.
- Counting Blood Cells, 132.
- Cotton, Antiseptic, to Prepare, 73.
- Cotton, Sterilized, for Removing False Membranes from the Throat, 176.
- Cover Glass Preparations, to Mount, 104.
- Cross Wires, A Study of Various Styles of, 179.
- Crytogenic Plant Material, Its Preparation and Use in Class Demonstrations, 220.
- Cullen's Method of Preparing Fresh Sections for Microscopic Work, A Modification of, 153.
- Culture of Anaerobic Bacteria in Liquid Media, 34.
- Culture of Diatoms, 34.
- Culture Media:
- Agar, to Prepare, 8, 62.
 - Asparagin Liquid Culture Media for Bacteria, 35.
 - Culture Media for Diatoms, 35.
 - Culture Media for the Differentiation of Species of Bacteria, 222.
 - Gelatin Media for Water Bacteria, 222.
 - Method for Preserving Culture Media, 72.

- Culture Media, continued:
 Methods for Preparing and Preserving Culture Media, 106.
- Current Botanical Literature, 182, 196, 215.
- Cytoplasm and Vacuoles, A Simple Method for Staining, 35.
- Decolorizing with Acid Alcohol, 104.
- Definition, Inferior, 5.
- Dehydrating and Infiltrating in a Vacuum, 69.
- Demonstration, The, of Karyokinesis, 80.
- Detection of Pathogenic Organisms, 175.
- Determination, Quantitative, of the Adulteration of Wheat Flour with Maize Products, 122.
- Determination of Supposed Defects in Microscopic Objectives, 5.
- Development of *Euphorbia corollata*, 197.
- Diagnosis and Description of Bacteria, 115.
- Diatoms, Culture of, 34.
- Dicotyl, A; its Embryonic Development, 215.
- Dies and Taps for a Standard Microscope Screw, 151.
- Diphtheria, Cause, Diagnosis, 176.
- Distribution of Spores, to Demonstrate, 220.
- Double Staining for Bacteria, 190, 212.
- Double Staining of Flagella, 191.
- Double Staining for Spores, 191.
- Durable Stain for Starch, 131.
- Dyes, Anilin, for Bacteria, 159.
- Dyes, Rosanilin; Their Relation to Microscopy, 69.
- Ebner's Solution, 213.
- Educational Value of Microscopical Work, 89.
- Effect of Leaving Material in Paraffin Bath for a Long Time, 203.
- Effects of the Removal of Capillary Water, or Hydrotropism, 15.
- Efficient Gas-Pressure Regulator, An, 92.
- Egg-Pipette, 129.
- Eggs, Fixing Fluid for, 82.
- Ehrlich's Forceps, 134.
- Ehrlich's Neutrophile Mixture, 135.
- Electrical Stimuli upon Plasmodia of Mycetozoa, 15.
- Electric Arc, The, Its Centration in Photo-Micrography, 115.
- Embryology of *Alyssum*, 215.
- Embryological and Histological Laboratory, Apparatus to Facilitate the Work of, 124.
- Embryological Laboratory of Cornell University, 26.
- Embryo of the Fish, Use of Modeling Clay in the Study of, 146.
- Embryonic Cartilage Cells, Stains for, 174.
- Endosperm, Sections for Class Work, 38.
- Endothelial Cells, to Stain, 83.
- Eosin, Directions for Staining with, 104.
- Eosin, Solution of, 102.
- Eosin and Van Gieson's Stain, Counter Staining with, 102, 104.
- Epithelium, Method for Studying, 201.
- Euphorbia corollata*, A Contribution to the Life History of, 197.
- Examination of Bacteria, 157.
- Examination of Milk for Tubercle Bacilli, 14.
- Examination of Sputum, 84.
- Eye, A Method of Preserving for Sectioning or for Demonstrating the Area of Acute Vision, 18.
- Ferric Chloride, A Test for Tannin in Seeds, 38.
- Filtering Apparatus, 9.
- Filter for Paraffin and Gelatin, 131.
- Finish, Black, for Table Tops, 145.
- Fish Embryo, The Use of Modeling Clay in the Study of, 146.
- Fixative, Albumen, 103.
- Fixing and Imbedding Lichens, 99.
- Fixing Blood Preparations, 134.
- Fixing Fluids for the Demonstration of Karyokinesis, 81.
- Fixing Fluids for Developing Eggs, 82.
- Fixing Fluids for Methylene Blue, 66.
- Fixing Plasmodia on the Slide, 97.
- Fixing Sections to the Cover-Glass, 103.
- Flagella, to Stain, 191.
- Flemming's Chromic-osmic-acetic Mixture, 196.
- Flemming's Fluid and Iron Haematoxylin for Algae, 156.
- Flour, Mounting Medium for, 122.
- Flour, Wheat, Its Adulteration with Maize, 122.
- Formalin, 40, 156.
- Formalin as a Reagent for Blood Studies, 189.
- Formalin, the Use of, in the Silver Nitrate Method of Staining Endothelial Cells, 83.
- Formulae for Solutions Used in the Laboratory:
 Albumen Fixative, 103.
 Anilin-Safranin, 181.
 Babes' Safranin, 82.
 Beth's Fixing Fluid, 66.
 Beck's Haematoxylin, 197.
 Boehmer's Haematoxylin, 102.
 Celloidin Solution, 71.
 Chromo-Acetic Acid, 156.
 Ebner's Solution, 213.
 Ehrlich's Neutrophile Mixture, 135.
 Fixing Fluids for Blood Preparations, 134, 189, 219.
 Fixing Fluids for Ova, 82.
 Fixing Solution for Blood, 219.
 Flemming's Chromo-aceto-osmic Solution, 81, 196.
 Formulae for Bacterial Stains, 192.
 Gentian Violet, 181.
 Hayem's Solution, 132.
 Heidenhain's Iron Haematoxylin, 81, 156.
 Hermann's Platino-aceto-osmic Solution, 81.
 Injecting Mass, 58, 135.
 Injecting Mass for Demonstrating Phagocytosis, 202.
 Injection Solution for Demonstrating Cell Bridges, etc., 201.
 Loeffler's Methylene Blue, 176.
 Macerating and Staining Medium for Vertebrate Nerve Tissue, 152.
 Methylene Blue, 65, 176.
 Meyer's Hemalum Solution, 102.
 Moeller's Liquid for Fixation, 223.
 Mounting Medium for Starch and Flour, 100, 122.
 Perenyi, 18.
 Picro-Acetic Solution, 82.
 Solution for Bleaching Red Corpuscles, 133.
 Solution of Eosin, 102.
 Solution for Making Neuroglia Preparations, 201.
 Spermatogenesis of *Scyllium canicula*, 199.
 Solution for Removing Pigment, 217.
 Solution for Staining Haematozoa of Malaria, 35.
 Solutions for Diluting Blood, 132.
 Solutions for Finishing Table Tops, 145.
 Toyson's Fluid, 133.
 Van Gieson's Stain, 103.
 Zenker's Fluid, 40.
 Ziehl's Carbolic Fuchsin, 178.
- Fuchsin and Gentian Violet, for Staining Bacteria, 159, 160.
- Fungi and Filamentous Algae, A Convenient Method for Mounting, 156.
- Ganglion Cells of the Mammalian Heart, 199.
- Gas-Pressure Regulator, 92.
- Gas Pressure, A Thermostat for High or Varying, 193.
- Gastric Juice, to Test for Pepsin or Carcinoma of the Stomach, 62.
- General or Protoplasmic Stains, 102.
- Gentian Violet, (Formula), 181.
- Gentian Violet for Staining Bacteria, 159-160.
- Geological Department of Johns Hopkins University, Courses Offered, 186.
- Geotropic Stimuli for Plasmodia of the Mycetozoa, 15.
- Germination of Spores of Mycetozoa, 1.
- Glandular Stomach of Birds, The, 107.
- Glandular Stomach of Birds, Method of Preparing, 152.

- Glass, Adventurine, Copper Crystals in, 95.
 Golgi Preparations, Note on the Method of Mounting, 85.
 Gonococcus Appearance, Detection of, 175.
 Gonorrhoea, Cause of Disease, Detection, etc., 175.
 Gram's Method for Double Staining Bacteria, 190, 212.
 Ground Ginger, Wheat Flour in, 51.
 Habitat and Collection of Plasmodia and Sporangia of Mycetozoa, 1.
 Haematoxylin Black, 197.
 Haematoxylin, Boehmer's, 102.
 Haematozoa of Malaria, Solution for Staining, 35.
 Hardening of Tissues for Microscopical Examination, 39.
 Haertung von Blut, Sputum, etc., auf Objecttraegern, 215.
 Hayem's Solution for Diluting Blood. (Formula), 132.
 Heidenhain's Iron Haematoxylin, Formula and Method of Staining, 81.
 Heidenhain's Iron Haematoxylin for Algae, 156.
 Hemalum Solution, Meyer's, for Staining Algae, 156.
 Hemalum Solution, Meyer's, (Formula), 102.
 Hermann's Fluid, (Formula), 81.
 Hints on the Construction of a Tow Net, 111.
 Histological and Embryological Laboratory, Apparatus for, 124.
 Histological Laboratory of Cornell University, 25.
 Histological Methods:
 For Bleaching Insects to Show Tracheae, etc., 175.
 For Cleaning Old Slides, 149.
 For Cutting Paraffin and Celloidin Sections, 87-88.
 For Demonstrating Cell Bridges, 201.
 For Demonstrating Fibrils of Striated Muscle, 3.
 For Demonstrating Leprosy and Tubercle Bacilli, 213.
 For Demonstrating Phagocytosis, 202.
 For Fixing Blood Preparations to the Cover Glass, 134.
 For Fixing and Mounting Blood Corpuscles, 189.
 For Fixing Plasmodia, 97.
 For Fixing Sections to the Cover Glass, 103.
 For Fixing Zoophytes and Polyzoa with Extended Tentacles, 201.
 Gram's Method for Double Staining Bacteria, 190, 212.
 For Hardening Tissues for Microscopical Examination, 39.
 For Histology of Nerve Tissue, 7.
 For Imbedding:
 In Celloidin, 71, 145.
 In Paraffin, 63, 70.
 In Soap, 68.
 For Imbedding Spores and Small Bodies, 202.
 For Improving Paraffin for Section Cutting, 67.
 For Injecting the Urinary Tubules of the Frog's Kidney, 58.
 For Making Neuroglia Preparations, 201.
 For Mounting Blood, 218.
 For Mounting Filamentous Algae and Fungi, 156.
 For Mounting Golgi Sections, 85.
 For Mounting the Tongue of a Blow Fly, 137.
 For Obtaining, Fixing and Staining Blood Preparations, 133.
 For Preparing Fresh Sections for Microscopic Work, 153.
 For Preparing the Glandular Stomach of Birds, 152.
 For Preparing Nucleated Blood, 187.
 For Preserving the Eye for Sectioning or for Demonstrating the Area of Acute Vision, 18.
 Quick Method of Preparing Sections of Tissue for Class Use, 33.
 For Rapid Hardening and Imbedding, 69.
 Histological Methods, continued:
 For Showing the Nature of the Cell Wall in Different Parts of the Seed, 38.
 For Staining Blood, 218.
 For Staining Flagella, 191.
 For Staining Yeast, 223.
 For Study of Mature Seeds, 37.
 For Washing Osmic Acid or Platinum Chloride Preparations, 129.
 To Demonstrate the Distribution of Spores, 220.
 Holder for Collodion Imbedding, 55.
 Howard University, Histological Laboratory of, 139.
 Human Blood, Methods for Microscopical Examination, 132.
 Hydathodes, the Morphology and Physiology of, 216.
 Hydrotropism in the Mycetozoa, 15.
 Illumination, Reduced, Some Causes of, 6.
 Imbedding in Celloidin, 71, 145.
 Imbedding, A Combination of the Paraffin and Celloidin Methods, 67.
 Imbedding Dish for Paraffin, 56.
 Imbedding and Fixing Lichens, 99.
 Imbedding, Paraffin; Points on the Technique of, 63.
 Imbedding Plant Tissues, Use of Soap for, 68.
 Imbedding Tissues for Cutting Sections, 70.
 Immunization, Proof of in Typhoid, 36.
 Improved Paraffin Imbedding Dish, 11.
 Inferior Definition, Possible Causes of, With Remedy, 5.
 Infiltrating and Dehydrating in a Vacuum, 69.
 Injecting Mass for Dissections, (Formula), 135.
 Injecting Mass, Preparation of, 58.
 Injecting Tubules of the Frog's Kidney, Method for, 58.
 Injection Solution for Demonstrating Cell Bridges, 201.
 Injection of Methylene Blue, 65, 199.
 Insects Bleached in Peroxide of Hydrogen, 175.
 Intensifying Negatives, (Method for), 73.
 Intra Vitam Staining of Plasmodia and Myxamoebae, 2.
 Investigators at Wood's Holl, List of, for 1898, 150.
 Iodine for Removing Mercury from Tissues, 41.
 Iron Haematoxylin, Heidenhain's:
 For Algae, 156.
 For Karyokinesis, 81.
 For Staining the Embryosac, 216.
 Irritability of Protoplasm, The, 15.
 Isolation of Bacteria, 158.
 Karyokinesis, The Demonstration of, 80.
 karyokinesis, Forms of, 197.
 Kellcott, David Simons,—Memorial, 79.
 Killing Reagents for Plasmodia and Myxamoebae, 16.
 Labels and Corks, 123.
 Laboratories, Representative American; Cornell, 23.
 Laboratories of Syracuse University, Medical Department, 162.
 Laboratory, Marine Biological, List of Investigators, 150.
 Laboratory Methods in Bacteriology, 157, 175, 190, 211.
 Laboratory Methods:
 Method for the Culture of Anaerobic Bacteria in Liquid Media, 34.
 Method for Demonstrating the Circulation of the Blood in the Capillaries, 101.
 Method of Demonstrating the Distribution of Spores, 220.
 Method for Demonstrating the Flow of Latex, 201.
 Method for Demonstrating the Motion of Cilia, 203.
 Methods of Determining the Positive or Negative Character of Mineral Plates in Converging Polarized Light with the Petrographical Microscope, 20.
 Method for Filtering Agar, or Gelatin, 201.

- Laboratory Methods, continued:
 Method for Marking the Position of an Object in the Field, 17.
 Method of Obtaining Swarm Spores, 220.
 Method for Studying the Dissemination of Plants by the Wind, 204.
 Method of Study of the Myxamoebae and the Plasmodia of the Mycetozoa, 1, 15.
 Method for Tabulating Laboratory Notes, 204.
 Laboratory Notes; Method of Mounting Sections, 156.
 Laboratory Supplies, Catalogue for, 31.
 Laboratory Tables, 121.
 Lantern Slides, to Clear up, 74.
 Leguminosae; Study of the Mature Seeds, 37.
 Leprosy and Tubercle Bacilli, 213.
 Lichens, Fixing and Imbedding, 99.
 Lichens, the Mounting of, 135.
 Literature, Current Botanical, 182, 196, 215.
 Locating Objects Under the Microscope by the Points of a Compass-Dial or of a Clock-Face, 116.
 Lockers for Specimens and Materials, 126.
 Löffler Bacillus; Appearance, Culture Tubes, Stains, 176-177.
 Löffler's Methylene Blue Solution (Formula), 176.
 Leydig's Fibres; Their Structure and Relation to the Neuron Theory, 219.
 Lumpy-Jaw, 178.
 Lye for Cleaning Old Slides, 149.
 Macerating and Staining Medium, for Vertebrate Nerve Tissue, 152.
 Magenta and Acid Magenta, Test for, 61.
 Magnifying Power, Editorial Note, 13.
 Maize Starch and Maize Flour in Mixture with Wheat Flour. A Note on the Detection of, 100.
 Makeshift Photo-Micrographic Apparatus, 77.
 Malaria, Staining of Haematozoa of, 35.
 Marine Biological Laboratory, List of Investigators, 150.
 Marker for Finding Microscopic Specimens 127.
 Marker for the Microscope, 204.
 Marsilia Quadrifolia, the Development of Leaf and Sporocarp in, 216.
 Mature Seeds, the Study of, 37.
 Mayer's Hemalum, 156.
 Measurements of Human Corpuscles, 185.
 Mechanical Stimuli, Effects of Upon the Myxamoebae, 15.
 Megoblasts in Their Relation to Anaemia, 218.
 Memorial—David Simons Kellicott, 79.
 Mercury, to Remove from Tissues, 41.
 Method of Improving Paraffin for Section Cutting, 67.
 Method of Marking the Position of an Object in the Field, 17.
 Methylene Blue:
 Ammonium Molybdate Method of Fixing, 66.
 Ammonium Picrate for Fixing, 66.
 Injection of, 65, 199.
 Löffler's Formula, for, 176.
 Method and Formula for Local Application of, 66.
 Method of Staining Nerve Tissues with, 64.
 Metric System in a Nut-Shell, 124.
 Meyer's Hemalum, 102.
 Micrometer Values, Ocular, Table of, 4.
 Micropyle, Its Structure in Leguminosae, 199.
 Microscope. A Marker for the, 76.
 Microscope, A New Portable, 136.
 Microscope, A Projection, 194.
 Microscope, in the High School, 11.
 Microscope, on a Man-o'-War, 83.
 Microscope Stand, A New Form of, 110.
 Microscope, The, as Practically Applied to Fish Culture, 221.
 Microscope, The Use of in the Detection of Adulterants in Powdered Drugs, 119.
 Microscopic and Microscopical, 149, 188.
 Microscopic Examination of Human Blood, 132.
 Microscopical Society, American, 147, 161.
 Microscopical Society, State, of New Jersey, 118.
 Microscopical Technique, Notes on, 39, 70, 85, 102, 132.
 Microscopical Work, Educational Value of, 89.
 Microscopic Work in Large Classes, 173.
 Microscopy, Laboratory of, Cornell, 26.
 Microtome Knife, Proper Angle of, 35.
 Microtome Knife, to Sharpen, 86.
 Milk Analysis by Centrifugal Force, 209.
 Mineral Plates, to determine the Positive or Negative Character of in Converging Polarized Light with the Petrographical Microscope, 20.
 Minerals, Biaxial and Uniaxial, 20.
 Mitosis, Illustrated by Photo-Micrographs, 47.
 Modeling Clay, the Use of in the Study of the Fish Embryo, 146.
 Modification of Cullen's Method of Preparing Fresh Sections for Microscopic Work, 153.
 Moeller's Liquid for Fixation, 223.
 Moist Chamber for Blood Preparation, 128.
 Motile Antherozoids, 182.
 Motion, Nuclear, in the Circulating Protoplasm of a Cell, 73.
 Mounted Slides and Material, Apparatus for Removing Air from, 74.
 Mounting Filamentous Algae and Fungi, 156.
 Mounting of Golgi Preparations, 85.
 Mounting Lichens, 135.
 Mounting Media for Starch Grains, 100, 122.
 Mounting Sections, 104.
 Mucous and Goblet Cells, to Stain, 62.
 Multipolar Spindles in Plant Cells, 183.
 Muscle, Striated, Platinum Chloride for Demonstrating the Fibrils of, 3.
 Mycetozoa, Aseptic Cultivation of, 96.
 Myxamoebae and Plasmodia of the Mycetozoa, 1, 15.
 Necturus, Tissues of, for Class Demonstration, 14.
 Negatives, to Intensify, 73.
 Nerve Tissue, Histology of, 7.
 Nerve Tissue, the Methylene Blue Method for Staining, 64.
 Nerve Tissue, Vertebrate, a Macerating and Staining Medium for, 152.
 Neuroglia Preparations, Method for Making, 201.
 New Colonimeter, A, 54.
 New Jersey State Microscopical Society, 118.
 News and Notes, 98, 118, 138, 150, 185, 201, 223.
 Note on the Mounting of Golgi Preparations, 85.
 Note on the Quantitative Determination of the Adulteration of Wheat Flour with Maize Products, 122.
 Notes Concerning the Histological Laboratory of Howard University, Medical Department, Washington, D. C., 139.
 Notes on Microscopical Technique, 39, 70, 85, 102, 132.
 Nuclear Division in Spirogyra, 201.
 Nuclear Motion in the Circulating Protoplasm of the Cell, the Demonstration of, 73.
 Nuclear Stains, 102.
 Nucleus, Theories of Heredity Based upon, 183.
 Ocular Micrometer Values, Table of, 4.
 Ohio State University, Department of Botany, 188.
 Optic Lobes of the Bird, 200.
 Osmometer and Root-Pressure Apparatus, 56.
 Ostracod Egg, its Development, 200.
 Oxygenating Plants for Aquaria, 193.
 Paraffin and Celloidin Methods of Imbedding, A Combination of, 67.
 Paraffin for Preserving Corks and Labels, 123.
 Paraffin for Section Cutting, A Method of Improving, 67.
 Paraffin Imbedding, 70.

- Paraffin Imbedding Dish, A Convenient, 56.
 Paraffin Imbedding Dish, Improved, 11.
 Paraffin Imbedding, Points on the Technique of, 63.
 Paraffin Imbedding Table, An Improved, 88.
 Paraffin Sections, A Cabinet for, 109.
 Paraffin Sections, The Cutting of, 87.
 Paraffin Sections, To Stain, 103-105.
 Parthenogenesis, bei *Antennaria alpina*, 196.
 Pathogenic Organisms, Detection of, 175.
 Pathology, Class Technique in, 9.
 Perenyi, Formula, 18.
 Permanence of Stains, 98.
 Permanent Stain for Starch, 181.
 Persistence of Bacteria in the Milk Ducts of the Cow's Udder, 205.
 Petrographical Microscope for Determining the Positive or Negative Character of Mineral Plates in Polarized Light, 20.
 Petrography in the Michigan College of Mines, 187.
 Pflanzenkernes, ueber die Reductionstheilung des, 197.
 Phagocytosis, Method for Demonstrating, 202.
 Photographic Dodges, Two, 73.
 Photographic Plates, Collection of Pond Life on, 115.
 Photography in the Biological Laboratory, 18.
 Photo-Micrographic Apparatus, A Make-shift, 77.
 Photo-Micrographic Camera and Condensing System, New Forms of, 117.
 Photo-Micrographic Camera, A Practical, 94.
 Photo-Micrographs, Mitosis Illustrated by, 47.
 Photo-Micrography, The Centration of the Electric Arc in, 115.
 Physiological Experimentation, Low Temperatures for, 192.
 Picro-Acetic Solution, 82.
 Picro-Carmine and Alum-Carmine as Counter Stains, 174.
Plaeodrina illinoisensis, Plankton Studies, 216.
 Plants, Oxygenating, for *Aquaria*, 193.
 Plant Tissues, The Use of Soap for Imbedding, 68.
 Plasmodia, To Fix and Stain, 97.
 Plasmodia, to Transfer to Glass Slides, 2.
 Plates, Mineral, to Determine the Character of in Polarized Light, 20.
 Platinum Chloride for Demonstrating Fibrils of Striated Muscle, 3.
 Polychaete Annelids, Studies on the Central and Peripheral Nervous Systems of, 219.
 Pond Life, Collection of on Photographic Plates, 115.
 Pontederiaceae, A Contribution to the Life History of, 198.
 Pork, Inspected by the Government, 14.
 Portable Microscope, A New, 136.
 Postal Microscopical Club, American, 181.
 Potassium Bichromate Solution for Cleaning Glass, 123.
 Powdered Drugs, The Use of the Microscope in the Detection of Adulterants in, 119.
 Preparing Fresh Sections for Microscopic Work, A Modification of Cullen's Method, 153.
 Preservation of Culture Media, Agar-Agar, 106.
 Preservative for Fresh Water Sponge, 73.
 Preserving Culture Media, Method of, 72.
 Projection Microscope, A New Departure, 194.
 Protoplasm, Its Rate of Motion in the Cell, 73.
 Pyrenomycete, New Species, 216.
 Quantitative Determination of the Adulteration of Wheat Flour with Maize Products, 122.
 Quick Method of Preparing Sections of Tissue for Class Use, 33.
 Quick Way of Preparing Agar, 8, 62.
 Radiolaria in Early Paleozoic Rocks, 185.
 Rapid Staining Apparatus, 169.
 Reagent Bottle, 203.
 Reagents for Killing *Plasmodia* and *Myxamoebae*, 16, 97.
 Recherches cytologiques sur la cellule de levure, 197.
 Red Corpuscles of Human Blood, Average Measurements, 185.
 Refractive Index and Alcohol-Solvent Power of a Number of Clearing and Mounting Media, 220.
 Relationships of the Bacteria, 183.
 Representative American Laboratories, Cornell, 23.
 Rheotropism in *Plasmodia*, 2.
 Rogers, Wm. A., A. M., Ph. D., LL. D., 155.
 Root Pressure Apparatus and Osmometer, 56.
 Rosanilin Dyes—Their Relation to Microscopy, 59.
 Rose-Bengale for Demonstration of Early Amyloid, 62.
 Royal Microscopical Society, Standard Microscope Screw of, 151.
 Sauer-Kraut, Bacteriological and Chemical Studies of, 222.
 Scheme for Counting Colonies of Bacteria in Petri Dishes when the Colonies are Small and Very Numerous, 84.
 Screen for Use in Microscopic Work, 125.
 Section Cutting, A Method of Improving Paraffin for, 67.
 Sectioning of Seeds, The, 32.
 Seeds, Mature, Some Methods in the Study of, 37.
 Sense Organs in Annelids, 219.
 Short Working Distance of Microscope: Cause, 6.
 Shrinking of Tissue, to Prevent, 152.
 Silver Nitrate Method of Staining Endothelial Cells, The Use of Formalin in, 83.
 Simple Method of Culture of Anaerobic Bacteria in Liquid Media, 34.
 Simple Steam Sterilizer, A, 33.
 Slide Boxes, Improvements for, 224.
 Slides, to Clean with Lye, 149.
 Soap, the Use of, for Imbedding Plant Tissues, 68.
 Solution for Macerating and Staining Vertebrate Nerve Tissue, 152.
 Solution for Making Neuroglia Preparations, 201.
 Some Methods of Determining the Positive or Negative Character of Mineral Plates in Converging Polarized Light with the Petrographical Microscope, 20.
 Spermatogenesis of *Scyllium canalicula*, 199.
 Spermatozooids of *Gingko*, 183.
 Spherical Aberration; Some Causes and the Remedy, 6.
 Spindles, Multipolar, of Plant Cells, 183.
 Spirogyra, Nuclear Division of, 201.
 Sponge, Fresh Water, A Preservative for, 73.
 Spores, to Demonstrate the Distribution of, 220.
 Spores of Mycetozoa, Germination of, 1.
 Sputum, Microscopical Examination of, 84.
 Sputum, Rapid Hardening of, 222.
 Staining Apparatus, Rapid, 169.
 Staining and Clearing:
 Carbolic Acid for Clearing, 152.
 Clearing Agents, 104, 220.
 Counter Staining with Eosin and Haematoxylin, 102-104.
 Decolorizing with Acid Alcohol, 104.
 Nuclear and Protoplasmic Stains, 102.
 Picro-Carmine and Haematoxylin for Embryonic Cartilage Cells, 174.
 Safranin-Gentian-Violet Orange Triplet Stain, 196.
 Staining and Fixing Blood Preparations, Method for, 133.
 Staining Haematozoa of Malaria, 35.
 Staining and Macerating Medium for Vertebrate Nerve Tissues, 152.
 Staining Nerve Tissues, The Methylen Blue Method for, 64.
 Staining Yeast, 97, 223.
 To Double Stain Bacteria, 190, 212.

- Staining and Clearing, continued:
 To Make Permanent Stains of Starch Bodies, 131, 181.
 To Stain Bacterial Spores, 35, 191.
 To Stain Celloidin Sections, 104, 105.
 To Stain Cytoplasm and Vacuoles, 35.
 To Stain Paraffin Sections, 103, 105.
 To Stain Starch with Silver Nitrate, 131.
 Stains, Permanence of, 93.
 Standard Taps and Dies for a Microscope Screw, 151.
 Starch, A Durable Stain for, 131.
 Sterilization of Cotton, 176.
 St. Louis Microscopical Society, 203, 224.
 Striated Muscle, Platinum Chloride for Demonstrating Fibrils of, 3.
 Structure de quelques ovules et parti qu'on peut tirer pour ameliorer la Classification, 193
 Study of Various Styles of Cross-Wires, 179.
 Study of Vital Phenomena. Intra Vitam Staining, 2.
 Sulphuric Acid and Potassium Bichromate for Cleaning Slides, 123.
 Summer Course of the Botanical Department of the University of Nebraska, 136.
 Table of Ocular Micrometer Values, 4.
 Tables, Laboratory, 121.
 Table-Tops, A Black Finish for, 145.
 Technique, Class, in Pathology, 9.
 Technique, Microscopical Notes on, 39, 70, 85, 102, 132.
 Technique of Paraffin Imbedding, Some Points on, 63.
 Temperatures, Low, for Physiological Experimentation, 192.
 Tests:
 For Early Amyloid, 62.
 For Free Acid in Gastric Juice (Congo Red), 62.
 For Hydrochloric Acid, (Benzo-Purpurin), 62.
 For Milk (Babeock), 210.
 For Tannin (Ferric Chloride), 38.
 For Tuberculosis, 178.
 Theories of Heredity Based Upon the Nucleus, 183.
 Thermo-Regulated Water Baths for the Bacteriological Laboratory, 108.
 Thermo-Regulator, A New, 91.
 Thermostat for High or Varying Gas Pressure, 193.
 Tissue, The Hardening of for Microscopical Examination, 39.
 Tissue, To Prevent the Shrinking of, 152.
 Tongue of Blow Fly, To Mount, 137.
 Tow Net, A, Hints on the Construction of, 111.
 Toyson's Fluid, Formula, 133.
 Transpiration, as Related to Sexual Organs, 217.
 Tubercle Bacilli, Examination of Milk for, 14.
 Tubercle Bacilli and Leprosy, 213.
 Tuberculosis, Detection, Staining, 177.
 Two Photographic Dodges, 73.
 Typhoid Vaccine, Trial of in England, 36.
 Ueber das Verhalten des Pollenschlauches bei der Ulme, 215.
 Ueber die Fixirungs Flussigkeiten, 218.
 Ueber Entwicklung und Ausbildung der Erythroblasten, 218.
 Unclean Lenses, 6.
 Uniaxial and Biaxial Minerals, 20.
 University of California, Biological Faculty, 186.
 University of Chicago, Laboratories for Plant Physiology, 186.
 University of Indiana, Summer Session of Biological Station, 201.
 University of Missouri, Biological Faculty, 186.
 University of Nebraska, Department of Botany, Courses Offered, 202.
 University of Pennsylvania, Vivarium, 186.
 Urinary Tubules of Frog's Kidney, to Inject, 58.
 Urine Sedimentation Apparatus, 113.
 Use of Modeling Clay in the Study of the Fish Embryo, 146.
 Use of the Microscope in the Detection of Adulterants in Powdered Drugs, 119.
 Vacuoles and Cytoplasm, Staining of, 35.
 Vacuum, Dehydrating and Infiltrating in, 69.
 Van Gleson's Stain and Eosin, Counter Staining with, 102, 104.
 Vertebrate Nerve Tissue, Solution for Macerating and Staining, 152.
 Verwandtschaftlichen Beziehungen zwischen den Phanerogamen und den Cryptogamen in Lichte der neuesten Forschungen, 217.
 Vital Phenomena, The Study of, 2.
 Wabash College, Department of Biology, 202.
 Wash-Bottle for Microscopists, An Improved Form of, 75.
 Washing Apparatus for Histological Purposes, 200.
 Washing Tissues Stained with Osmic or Chromic Acid, 129.
 Water Bath, A Convenient, 33.
 Water Baths, Thermo-Regulated for the Bacteriological Laboratory, 108.
 Wheat Flour in Ground Ginger, 51.
 Wheat Flour, A Note on the Detection of Maize Starch and Maize Flour in Mixture with, 100.
 Wheat Flour, A Note on the Quantitative Determination of its Adulteration with Maize Products, 122.
 Yeast, Its Structure and Reproduction, 224.
 Yeast, Nuclear Characteristics of, 197.
 Yeast, Staining of, 97, 223.
 Zenker's Fluid for Fixing, 40.
 Ziehl's Carbohc Fuchsin, Formula, 178.
 Zoospores, to Obtain Drop Cultures of, 220.
 Zur Physiologie der Fortpflanzung einiger Pilze, 217.

INDEX TO AUTHORS.

- Alleger, W. W.,
Agar, 8.
- Ayers, Howard,
Methods of Study of the Myxamoebae
and the Plasmodia of the Mycetozoa,
1, 15.
- Bausch, Edward,
Determination of Supposed Defects in
Microscope Objectives, 5.
A New Microscope Stand, 110.
A New Portable Microscope, 136.
- Bausch, Henry,
A Practical Photo-Micrographic Cam-
era, 94.
- Bessey, Charles E.,
A Marker for the Microscope, 76.
- Bioletti, Frederic T.,
A Method of Preserving Culture Media,
72.
- Bliele, A. M.,
David Simons Kellicott—Memorial, 79.
- Bodine, Donaldson,
A Thermostat for High or Varying Gas
Pressure, 193.
- Carter, Marion Hamilton,
Agar, 62.
- Chamberlain, Charles J.,
A Convenient Method for Mounting the
Filamentous Algae and Fungi, 156.
Reviews of Current Botanical Litera-
ture, 182, 196, 215.
- Claypole, Agnes M.,
Animal Biology—Reviews of Current Lit-
erature, 199, 217.
- Claypole, E. W.,
Educational Value of Microscopical
Work, 89.
- Dahlgren, Ulric,
A Combination of the Paraffin and Cel-
loidin Methods of Imbedding, 67.
- Dennis, D. W.,
On Demonstration of Nuclear Motion in
the Circulating Protoplasm of a Cell,
73.
- Dodge, Charles Wright,
A Durable Stain for Starch, 131.
Laboratory Tables, 121.
The Microscope in the High School, 11.
Yeast, 223.
- Eisen, Gustave,
Corks and Labels, 123.
- Elliott, L. B.,
American Microscopical Society, 161.
Representative American Laboratories:
Cornell University, 23.
- Ewell, E. E.,
A Note on the Detection of Maize Starch
and Malze Flour in Mixture with
Wheat Flour, 100.
A Note on the Quantitative Determina-
tion of the Adulteration of Wheat
Flour with Maize Products, 122.
- Firmin, George D.,
A Makeshift Photo-Micrographic Appa-
ratus, 77.
- French, G. H.,
The Glandular Stomach of Birds, 107.
Mounting Lichens, 135.
- Frost, W. D.,
A Black Finish for Table Tops, 145.
- Gage, Simon Henry,
Platinum Chloride for Demonstrating
Fibrils of Striated Muscle, 3.
Some Apparatus to Facilitate the Work
of the Histological and Embryological
Laboratory, 124.
William A. Rogers, A. M., Ph. D., LL. D.,
155.
- Harrison, F. C.,
Celloidin Imbedding, 145.
- Heald, George H.,
A Scheme for Counting Colonies of Bac-
teria in Petri Dishes when the Colonies
are Small and Very Numerous, 84.
- Huber, G. Carl,
Laboratory Notes, 156.
The Methylene Blue Method for Staining
Nerve Tissues, 64.
A Note on the Mounting of Golgi Prepa-
rations, 85.
Notes on Microscopical Technique, 39,
70, 85, 102, 132.
The Use of Formalin in the Silver Nitr-
ate Method of Staining Endothelial
Cells, 83.
- Humphrey, H. B.,
Low Temperatures for Physiological
Experimentation, 192.
- Jeffers, H. W.,
An Apparatus to Facilitate the Count-
ing of Colonies of Bacteria on Circu-
lar Plates, 53.
- Kingsbury, B. F.,
The Demonstration of Karyokinesis, 80.
- Kirsch, A. M.,
Two Photographic Dodges, 73.
- Kizer, Ernest I.,
Formalin as a Reagent for Blood Stud-
ies, 189.
- Knapp, Wm. H.,
Mitosis Illustrated by Photo-Micro-
graphs, 47.
- Kofoed, Charles A.,
Hints on the Construction of a Tow Net,
111.
- Lamb, Frank Haines,
Some Points on the Technique of Par-
affin Imbedding, 63.
- Lamb, J. Melvin,
Some Notes Concerning the Histological
Laboratory of the Howard University
Medical Department, Washington, D.
C., 139.
- Latham, V. A.,
The Rosanilin Dyes—Their Relation to
Microscopy, 59.
- Mabon, William,
A Convenient Water Bath, 33.
- Mabry, T. O.,
A Simple and Convenient Method for
Demonstrating the Circulation of the
Blood in the Capillaries, 101.
- MacDougal, D. T.,
Apparatus for Removing Air from
Mounted Slides and Material, 74.
An Osmometer and Root-Pressure Appa-
ratus, 56.
- Mark, E. L.,
A Table of Ocular Micrometer Values,
4.
- McFarland, Joseph,
The Coccidium Oviforme, 41.

- McGill, A.,
Wheat Flour in Ground Ginger, 51.
- Mix, A. B.,
A Rapid Staining Apparatus, 169.
- Moore, Veranus A.,
Thermo-regulated Waterbaths for the
Bacteriological Laboratory, 108.
- Morrill, A. D.,
A Cabinet for Paraffin Sections, 109.
- Munson, W. H.,
Photography in the Biological Labora-
tory, 18.
- Murrill, Paul,
An Efficient Gas-Pressure Regulator, 92.
- Myers, B. D.,
Picro-Carmine and Alum-Carmine as
Counter Stains, 174.
- Myers, Wm. H.,
The Microscope on a Man-o'-War, 83.
- Novy, F. G.,
Laboratory Methods in Bacteriology,
157, 175, 190, 211.
A New Filtering Apparatus, 9.
A Simple Steam Sterilizer, 33.
A New Thermo-Regulator, 91.
- Osborn, Henry L.,
A Convenient Method of Histology for
Nerve Tissue, 7.
- Pammel, L. H.,
Some Methods in the Study of Mature
Seeds, 37.
- Peabody, James E.,
Microscopic Work in Large Classes, 173.
- Peirce, George J.,
Fixing and Imbedding Lichens, 99.
- Revenel, Mazyck P.,
Agar-Agar. The Preservation of Cul-
ture Media, 106.
- Sangree, Ernest B.,
Class Technique in Pathology, 9.
Dehydrating and Infiltrating in a
Vacuum, 69.
- Sayre, L. E.,
The Use of the Microscope in the De-
tection of Adulterants in Powdered
Drugs, 119.
- Schaffner, John H.,
An Improved Paraffin Imbedding Dish,
11.
A Permanent Stain for Starch, 181.
- Slonaker, James Rollin,
A Method of Preserving the Eye for
Sectioning, or for Demonstrating the
Area of Acute Vision, 18.
- Smith, Frank,
A Method of Improving Paraffin for
Section-Cutting, 67.
- Stevens, James S.,
A Study of Various Styles of Cross-
Wires, 179.
- Sturgis, W. C.,
An Improved Form of Wash-Bottle for
Microscopists, 75.
- Thomas, Mason B.,
The Sectioning of Seeds, 32.
- Treadwell, A. L.,
The Use of Modeling Clay in the Study
of the Fish Embryo, 146.
- Wadsworth, M. E.,
Some Methods of Determining the Posi-
tive or Negative Character of Mineral
Plates in Converging Polarized Light
with the Petrographical Microscope,
20.
- Ward, Archibald R.,
The Persistence of Bacteria in the Milk
Ducts of the Cow's Udder, 205.
- Ward, Henry Baldwin,
An Improved Form of Paraffin Imbed-
ding Table, 88.
- Ward, R. H.,
American Postal Microscopical Club,
181.
Microscopic and Microscopical, 149.
- Washburn, F. L.,
A Preservative for Fresh Water Sponge,
73.
- Weiss, Julius,
A New Colonometer, 54.
- Wilcox, E. Mead,
A Convenient Paraffin Imbedding Dish,
56.
A Holder for Collodion Imbedding, 55.
The Use of Soap for Imbedding Plant
Tissues, 68.
- Woll, F. W.,
Centrifugal Milk Analysis, 209.
- Woods, Albert F.,
Cultivation of Algae in Aquaria, 193.

Journal of Applied Microscopy.

VOLUME I.

JANUARY, 1898.

NUMBER 1

Methods of Study of the Myxamoebae and the Plasmodia of the Mycetozoa.

HOWARD AYERS, Ph. D.

Professor of Biology, University of Missouri.

HABITAT AND COLLECTION OF PLASMODIA AND SPORANGIA.

For purposes of experiment and demonstration of the morphology and physiology of protoplasm, the Mycetozoa furnish us with the most satisfactory material. In the plasmodial condition the protoplasmic bodies are of mass and extent sufficient for all the needs of experiment. While it is true that these forms of life have been much used to advance our knowledge of the processes and the material substratum of life, it is equally true that they have not been as much used as they might well have been. The purpose of this paper is to make plain how abundant this material is about us and how it may be used in class demonstration or for original research. In all parts of the United States except the desert and snow-covered localities the Mycetozoa are abundantly represented by genera such as *Trichia*, *Arcyria*, *Hemiarcyria*, *Stemonitis*, *Didymium*, etc., with numerous species, and during the warm spring, summer and fall seasons the plasmodial forms may be found in the moist, quiet localities of forest and woodland, creeping in their fashion over the surfaces of decaying stumps, logs and fallen leaves and occasionally on the naked earth where it is full of organic remains. The ripe sporangia are to be found in the same localities. Plasmodia will be found abundant immediately after warm showers, especially on sultry, sweltering, summer days when the atmosphere is surcharged with moisture. Newly formed fruiting bodies, or those in the act of forming may be had abundantly on the dry days succeeding such moist periods. The plasmodia of our common American species are either yellow, brown or reddish brown in color and are

usually found in a much branched condition, spread out upon the decaying wood from which they get their food. They may be easily collected and safely carried to the laboratory or greenhouse by placing the pieces of wood on which they are spread and which have been cut off from the tree trunk with knife or hatchet, in a botanist's collecting case which has been lined with wet filter paper or other good absorbent. Any tin box or glass jar will serve, but a receptacle hung from the shoulder will be found much more convenient than one which must be carried in the hand. On reaching the laboratory the pieces of wood should be placed in dishes under bell jars, with pieces of wet blotting or filter paper to maintain the moist atmosphere required for their growth. In such a growing chamber they may be kept indefinitely, or until they form their fruiting bodies. Here they may likewise be fed on any food it is desired to experiment with. The plasmodia of the Mycetozoa move rapidly when in search of food. This is especially true of the young plasmodia and of the myxamoebae. Hence, when it is desired to keep them under direct microscopic observation, they should be fed previous to any attempt to study them. This may be done by placing them in food solutions or feeding them with small particles of animal and plant tissues. After feeding they remain quiet for a time and during this period may be studied to advantage. They may be kept alive indefinitely if supplied with abundance of food and moisture.

THE GERMINATION OF SPORES.

The spores of most species of Mycetozoa germinate at the ordinary spring and summer temperatures of their habi-

tats. Only a few species require a nutrient solution to coax the growth, all the remaining forms growing readily in ordinary spring, or other, water. My best results have uniformly been obtained by sowing in pasteboard cells and the success of this cell is apparently due to the retention of moisture within the cell. Another excellent feature of such a cell is the rapidity with which water is carried from the outside to the chamber inside, thus removing the necessity for disturbing the culture glass on account of drying. These cells are made as follows: A small sized gun wad-cutter is used to make holes in a sheet of pasteboard (which must be not too thick since it will swell when wet to perhaps three times its thickness when dry) and then a larger cutter is used to remove a ring of pasteboard not to exceed an eighth of an inch in width. These rings are cemented to the slide by a thin layer of balsam and when thoroughly dry are ready for use. The cover glass, which should overlap the ring all around, is thoroughly cleaned and a drop of nutrient solution or water, as the case may be, is placed in the center, the spores sown in it with a needle, and it is then inverted over the pasteboard ring, which has, in the meantime, been soaked full of water. A second slide placed on top of the ring during the soaking process will prevent uneven swelling of the ring. The culture is now ready for observation, and the myxamoebae may be observed with both low and high powers if care is taken in regulating the size of the drop. Such a cell may be arranged for the study of the effects of any of the normal stimuli as well as of reagents. Cultures made in this way serve admirably for the study of the transition of protoplasmic into ciliary motion and vice versa, and they are unequaled for the investigation of the streaming of protoplasm and the contents of the vital substance. In all cases the cells must be carefully protected from contamination with fungi and bacteria, both in the sowing and the later stages of the culture, otherwise their period of usefulness will be short indeed. Loss from evaporation is easily prevented by keeping in a moist chamber when not under observation and by the addition of drops of water to the outside of the pasteboard ring when the cell is exposed to dry air. If the purpose of the germination of the spores is not the study of the myxamoebae, but the production of plasmodia, this end may best be reached by sowing on decayed bark or rotten wood under bell jars where the natural conditions are fully reproduced. Plasmodia may thus be raised at any season of the year and in any quantity. A super-

abundance of excellent material may thus be prepared for the use of the investigator or for demonstrations to large classes. It is essential to keep even temperatures of from 85 to 100 degrees F. in order to secure rapid growth of the cultures.

TO TRANSFER PLASMODIA FROM ANY SUBSTRATUM TO GLASS SLIDES FOR MICROSCOPIC STUDY.

Plasmodia may readily be transferred to glass slides in a short time in either of the following ways: A clean glass slide is placed against a piece of the decayed wood under a bell jar where it is being kept as described in a previous paragraph and supported in such a manner that its lower end is in contact with the edge of the plasmodium. A gentle current of water is now allowed to flow down the slide, either from wash bottle as shown in Fig. 1, or by dropping water from a pipette, when the protoplasm will begin to flow upwards on the slide and soon cover it sufficiently for the purpose of the study. This reaction to a current of water is known as Rheotropism and is as remarkable as it is evident. Another, and in many respects similar, method is to place as many slides as desired on a glass plate and on these small pieces of the plasmodium-bearing wood, covering the whole with a bell jar. In the course of a few hours, the time depending on the temperature and other conditions of the environments, the plasmodia will be found beautifully expanded and in full migration upon the surface of the slides. These may be taken up and immersed in the killing reagents or used for study by classes or in original investigations, without further preparation. This is the easiest and surest way of securing those huge multinucleate amaeoboids for the use of classes, and since the supply at any time is limited only by the collections (if in summer) or by the sowings (if in winter) there need be no lack of either myxamoebae or plasmodia in any laboratory.

THE STUDY OF VITAL PHENOMENA. INTRA VITAM STAINING.

To stain the plasma in living plasmodia and myxamoebae.—If the former, get the plasmodium on the slide in the manner already described and allow it to be spread out and form slender radiations. Cover some of these with a suitable sized cover glass supported on wax feet, after which the stains may be run under the cover. The action is prompt and the colored solution may be readily washed out or replaced with rain or tap water when the preparation is ready for study.

If the latter, make the preparation either by germinating on the slide or else in a manner commonly used for the study of amoebae, and introduce the staining medium under the cover glass. Study while coloring and if desired, after complete staining of the plasma has taken place, the staining solution may be removed and the preparation either studied living or fixed and made into a permanent mount.

The following stains may be used; the first four have given me the best results: Methylene blue, malachite green, violet Dahlia No. 170, methyl violet, Bismark brown, cyanin, fuchsin, safranin. It will be well to try Congo, which is said not to be poisonous to protoplasm even in strong solutions. The solutions of these substances must be made extremely dilute (from 1-10,000 to 1-100,000) and they should never be acid, but either neutral or only slightly alkaline.

These stains may be made with serum and normal salt solution as well as with water. Some of these stains will also stain the nuclei, but none of them will give the nuclear differentiation to be had with the carmine and aniline dyes applied in the usual ways after the plasma have been properly fixed.

To be continued.

Platinum Chlorid for Demonstrating the Fibrils of Striated Muscle.

SIMON HENRY GAGE.

Since the great monograph of Bowman* on the structure of muscle, the fundamental facts presented by him still are the ones represented in the best modern text-books, although in some details there has of course been considerable modification.

If one consults this monograph, or a later monograph or book on the histology of muscle, one can but be impressed with the fact that there is a great preponderance of discussion upon the structure in lower forms, insects, fishes, and amphibia. This is true, although the book may be entitled "Human Histology."

If one seeks for methods to demonstrate the various appearances figured and described, it will be found that it frequently requires days, weeks, or even months, to get the preparations ready for study. For the investigator who is carrying on several pieces of work at the same time, this may not be a drawback; but in the case of the teacher with classes having but a limited time for work, he must prepare material a long

time in advance, and thus the students be deprived of the actual personal experience which they can alone obtain by taking every step themselves, or some method must be devised which shall be both certain and rapid. Owing to the constant effort of laboratory teachers, every year adds to the list of such rapid and excellent methods. In my own field, where mammalian histology and embryology are of principal importance for my laboratory students, there is a constant effort to find methods applicable to such animals in the published accounts of others and by personal experiments. So much effort is made because, while the type may be the same in different animals, the details of structure are often markedly different in the different forms, and it seems hardly fair to students to show them only insect muscle, for example, and lead them to assume that the appearances are exactly the same in mammals.

In studying the tissues of animals, one of the greatest needs is some means of isolating the cells or structural elements so that details of form and structure may be made out with certainty, and the confusion arising from overlying or underlying cells avoided. While making a series of experiments on different media for dissociation, it was found that platinum chlorid in a one-tenth per cent. aqueous solution (platinum chlorid 1 gram, water 1000cc-), acting from two to twenty-four hours, gave most beautiful preparations of the longitudinal striation and the fibrils of mammalian muscle. In many cases, if the teasing was thorough, the fibers appeared like a skein of thread, and frequently the fibrils were detached from the bundle, thus affording opportunity for their special study.

The method has been applied to mammals (man, horse, dog, cat, sheep, rabbit, guinea pig), amphibia, fishes, insects, and cray-fish. It is well adapted to all, but more especially to the mammalian muscle, where the demonstration of fibrils and longitudinal striation is more difficult or requires more time than in the lower forms.†

†Many good dissociators for special purposes have been devised, but so far as I know there has been no generalization of the fundamental principles which would serve as a guide in case one had not access to the special liquid described. In a series of experiments to see if there was not some underlying principle, the writer came to the conclusion that, while a given detail of structure or a given kind of cells might be more clearly demonstrated by one method than by another, yet the generalization seemed justified that "Any medium which fixes a tissue well may be used to isolate its structural elements if employed in a proper dilution (about one-tenth the strength used in fixing) and allowed to act

*Phil. Trans. 1840-41, pp. 457-501, 4 plates.

In practice about five times as much liquid is taken as muscle, and the piece of muscle should not be larger than one's little finger. Very small pieces should be worked on within a few hours, two to five, while larger pieces may wait longer. That is there is too great hardening of the tissue if the solution acts on a small mass for a considerable time. For a simple, temporary demonstration a shred or fascicle is removed from the mass of muscle and teased out in water or in some of the dissociating liquid, but if one wishes to demonstrate the finest details, and to see with clearness the various discs described in modern works he should proceed as follows: A small fascicle is teased very thoroughly in a drop of water. One may use a tripod magnifier to make sure that the teasing is thorough. The water is drained off and two or three drops of a two per cent. solution of erythrosin in fifty per cent. alcohol is added and left for five minutes; or one may use a two per cent. aqueous solution of eosin. Either of these agents will stain the parts of the fibrils which appear dark in unstained preparations, but the erythrosin is preferable. After five minutes the stain is poured off carefully, and the fibers are washed with several drops of water and then dehydrated with 95 per cent. or stronger, alcohol (two or three pipettes full will suffice). A drop of clearer (carbolic-turpentine or carbolic-xylene) is added after pouring off the alcohol, and the fibers are carefully separated with needles, and after pouring off the clearer a cover spread with balsam is put over them. If the preparation is successful, and most of them are, one gets a very satisfactory view of the minute structure as well as of the general structure, as some of the fibers will show with perfection the transverse striae, others the longitudinal striae and the isolated fibrils. For seeing the minute details, a good homogeneous immersion objective and careful lighting are necessary.

If a muscle is found to give good preparations it may be preserved for at least three years in fifty per cent. alcohol and give good results.

One feature of our February issue will be the first of a series of illustrated articles entitled "Representative American Laboratories." The laboratories of Cornell University will be the first subject.

only a limited time—two to twenty-four hours. See "Proceedings of the Amer. Micro. Soc. for 1897." It was in this series of experiments, made three years ago, that the special excellence of platinum chlorid for demonstrating the longitudinal striation and fibrils of muscle was discovered.

A Table of Ocular Micrometer Values.

I have been accustomed for several years to make use of a table of ocular micrometer values in all my microscopic measurements and to recommend to students the desirability of preparing such tables for their own use. At the risk of calling attention to what may already be widely employed, though I do not remember to have seen any allusion to a table of this kind, I will give an exact copy of one of the tables which I make use of and a brief statement concerning it.

Zeiss 3846. Tube length (including revolver). 160 mm.	OBJECTIVES.		
	A 6385	C 2542	D 1286
Microm. oc. $\frac{2}{34}$	μ	μ	μ
Divisions			
1	12.8	3.6	2.4
2	25.6	7.2	4.8
3	38.4	10.8	7.2
4	51.2	14.4	9.6
5	64.0	18.0	12.0
6	76.8	21.6	14.4
7	89.6	25.2	16.8
8	102.4	28.8	19.2
9	115.2	32.4	21.6

The essential feature of this table is, that it gives in a compact form the value not only of one division of the ocular micrometer, but the values corresponding to each of the nine digits, from which one can quickly compute mentally the value of any number of divisions. If the real image of an object measures ten divisions of the micrometer or less, the size of the object may be read directly from the table, provided that the image corresponds with an exact number of the divisions. If, on the contrary, the size of the image exceeds a certain number of divisions by some fraction of a division, the value of this fraction, estimated in tenths of a division, may be quickly ascertained (a tenth of the corresponding unit value in the table) and mentally added to the value of the whole number of divisions. For example, a given object viewed with objective A measures 7 divisions (89.6 μ) and the fraction, estimated at 0.5 of a division, (6.4 μ); the sum of the corresponding values is seen at a glance to be 96 μ . Likewise, if the object measures more than 10 divisions, its value is quickly found from the table by a simple multiplication or addition. For example, 13 divisions have the value of 3x6, or 10 plus 8, divisions; 17 divisions are equivalent to 10 plus 7, or, better, 8 plus 9 divisions, since the value of 8 and 9 are contiguous in the

table, and therefore allow a quicker summation.

In constructing such a table, it is of course essential that every variable which can affect the value of a division of the ocular micrometer should be accurately noted, e. g., the tube length and the maker's number on the objective; even the particular ocular employed * should be indicated, for the collective lens is not exactly the same for all oculars bearing the same designation. While it is not necessary to express in the table values less than tenths of micra, it is of course necessary to compute the value of one division to hundredths of micra, so that when multiplied, e. g., by nine, the true result may be expressed to the nearest tenth of a micron. The table given is one of several constructed on the same plan for different tube lengths. A table for a single tube length, however, answers most purposes, because the tube length can be quickly adjusted to that employed in making out the table.

E. L. MARK.

Cambridge, Mass., Dec. 6, 1897.

*Oc. 2, No. 34, in the above Table.

The Determination of Supposed Defects in Microscope Objectives.

EDWARD BAUSCH.

The methods of making lenses for microscope objectives, although in the main the same as have been used for many years past, are changed in one direction by the leading, reputable makers in so far as to eliminate the personal factor of skill in one or another workman. In the process of grinding and polishing lenses this is accomplished by the so-called "color test," and a standard being established by the maker, it is carefully maintained by one person whose judgment is authoritative. The next steps of centering, cementing, mounting, and adjusting are all carefully controlled, and when the preliminary testing in the microscope on suitable test objects is reached, any defects which may exist are so apparent as to be easily distinguished by one skilled in the art. Defects may consist of:

(1.) The wrong figure in one of the surfaces, due to a strain in one of the lenses while it is in process of work.

(2.) To a decentered lens.

Either of these defects is easily recognized, when it is simply necessary to determine in which lens or system it exists and replace it by another; although it may be said in passing that this necessity seldom exists. The deviations in

spherical and chromatic corrections are represented by the proper adjustment of the relative distances of the systems, in which positions they are permanently fixed. The modern mode of close control and exact tests brings the variation within such narrow limits that it is almost impossible to find any difference in objectives of the same kind. In making this statement I am well aware of the common belief that the microscope objectives, dependant as they are upon individual will and skill, are therefore variable in their results, but repeat that this belief is well founded only in the productions of former years and at the present time only by the producers of inferior objectives. It is of course apparent that the maintenance of a standard lies within the limitations which the maker may prescribe, but in the case of the few leading, reputable firms, I can attest, from personal knowledge, that a sample of one kind of objective is typical for those of its class. When, therefore, complaints are occasionally made that objectives possess defects, among which are principally mentioned inferior definition, spherical aberration, reduced illumination, and short working distance, the question naturally arises in the mind of the optician, whether, if these complaints are warranted, the objectives are used under normal conditions—that is, corresponding to those under which they were produced. From his knowledge of the capacity of each objective he must assume that they are not, and it is the purpose of this paper to point out the conditions under which the objectives may be used which create the impression of their being defective. These remarks apply equally to the medium and high-power objectives, either dry or immersion.

Inferior Definition.

This may be due to:

(1.) Covers which vary in their thickness considerably from the standard.

In the case of thick covers spherical over-correction is created, so that the plane of definition is above the plane or outline of the object. In this case the focal distance of the objective must be increased to obtain definition.

In the case of thin covers, the best definition lies below the plane of the object and indicates spherical under-correction. The focal distance of the objective must be decreased for the best definition, or spherical correction may be made by suitably increasing the tube length.

The variation in either direction may be so considerable as to make it impossible to obtain any definition at all.

In oil-immersion objectives, the variations in cover glasses have but little

effect, as the cover, oil, and front lens of the objective form a practically homogeneous mass.

REMEDY.—*Use cover glasses varying little from the generally accepted standard, i. e., 0.16 mm.*

(2.) Improper Use of Abbe Condenser.—A superabundance of light obliterates all detail and creates a glare uncomfortable to the eye.

REMEDY—*Except in the case of oil immersion objectives on stained bacteria, when the condenser is used with the full opening, the aperture of the condenser should always be reduced to a trifle less than the angular aperture of the objective.*

In histological, and other dense objects, reduce the Iris diaphragm to about one-half the opening of rear lens in objective.

On diatoms reduce the diaphragm to about two-thirds the rear lens in objective.

The diameter of rear lens may be judged by removing the eyepiece.

Unclean Lenses.

If in either objective or eyepiece the lenses are not clean, the definition may be seriously reduced or destroyed. Finger marks upon the front lens of objective, or upon eyepiece lenses, dust which in time may settle upon rear lens of objective or on eye lens, film which forms upon one or the other lens, due occasionally to the fact that glass is hygroscopic, but generally to the exhalation from the interior finish of the mountings; and, finally, in immersion objectives, because the front lens is not properly cleaned, or oil has leaked onto its rear surface, or air bubbles have formed in the oil between the cover glass and front lens. The latter two causes may totally destroy all definition, no matter how excellent the objective is or may have been.

REMEDY.—*Keep all lenses scrupulously clean. For cleaning, use well-washed linen (an old handkerchief) or Japanese lens paper.*

Eyepieces.—To find impurities, revolve the eyepieces during observation; breathe upon the lenses, and wipe gently with a circular motion and blow off any particles which may adhere.

Dry Objectives.—Clean front lens as above. To examine rear and interior lenses use a two-inch magnifier, looking through the rear. Remove dust from rear lens with a camel's hair brush.

Oil-Immersion Objectives.—Invariably clean front lens after use with a moistened linen or paper, and wipe dry.

In applying oil examine the front of objective with a magnifier, and if there are any air bubbles remove with a pointed quill, or remove oil entirely and apply a fresh quantity.

Spherical Aberration.

This may be caused by:

(1.) Covers varying from normal thickness: treated under "Inferior Definition" with the same remedy.

(2.) Tube length varying from the normal length to which objectives are corrected.

REMEDY.—*Cover glass of standard thickness; tube length according to correction of objective.*

The pernicious influence of covers varying from normal thickness is thus again emphasized, and can not be too strongly impressed.

Reduced Illumination.

This may be caused by:

(1.) Higher-power eyepiece. There is a proportionate increase in loss of light as the power of eyepiece is increased, or,

(2.) Between two objectives of different power, the higher will give less illumination.

(3.) Small aperture and diaphragm, either with or without condenser.

(4.) Thick section or dense object.

(5.) Mirror tilted so as not to give complete illumination or to cause the reflection of an obstruction, such as a window sash, to fall in the optical axis. This latter feature may not only affect the amount but the character of the illumination, as oblique illumination may be obtained even when the mirror is in the central position by suitably tilting it.

Short Working Distance.

This may be created by:

(1.) The use of thicker cover glasses than the normal; in abnormally thick ones, when the air space between the objective and cover is taken up by the increased thickness of the latter, it may even prevent reaching a focus on the object.

(2.) Thick sections or objects may reduce working distance to such an extent as to prevent focusing through the cover.

(3.) If the cover is not in direct contact with the object, it may be and often is reduced.

In conclusion, I would add that there remains still one more factor, that of accidental injury to the objective by falling or coming in violent contact with the cover while focusing, against which every precaution should be used. The front lenses are the most exposed and at the same time the most delicate, and contact against a hard surface is likely to displace or injure them. Particularly is this the case in the oil-immersion

objectives, where the front lens and cell are exceedingly frail and the slightest displacement, while it may not be apparent at first, will in time almost with certainty permit the leakage of oil around it to the interior, and thus destroy its utility.

A Convenient Method for Histology of Nerve Tissue.

HENRY L. OSBORN, St. Paul, Minn.

Histologists are generally of the opinion that materials for study must be perfectly fresh, and, for the best work, anyone would naturally reject material which was not obtained alive. In getting material for elementary class work, however, it is not absolutely necessary to have perfectly fresh material, and I have found that I can use a number of different tissues that can be bought at the butcher's shop in demonstrating the coarser facts.

After reading in Stirling's *Histology*, page 216 (edition of 1896), the method there given for showing the multipolar nerve cells, I determined to give it a trial on some spinal cord obtained from my butcher. The beef from which I took the tissue had been killed at least two weeks previously, during May. The cord could be seen in the spinal canal as the beef was hanging in the shop, and hence had been drying on the surface.

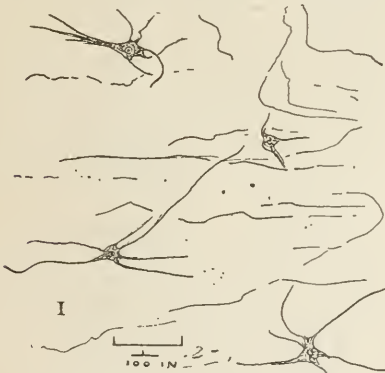

A small particle of the gray matter from the anterior root was placed on a cover glass, and a second cover glass placed directly on it and squeezed down so as to smear the gray matter evenly over both glasses. The covers were then separated and floated, film downwards, on a saturated solution of methylene blue for two hours. Then they were washed in distilled water and dried; and finally, after exposure to a gentle heat to thoroughly dry them, they were directly mounted in balsam.



The method is so direct and easy of application that it is available for the beginner. In order to test its possibilities, I give a drawing from one of the slides made by the method. I do not think of any better way in which to show the value of a method than to show some of the work done with it. The drawings were all of them made with a camera lucida and are made not in the least diagrammatic. Figure 1 is a view of a part of one field showing four nerve cells as they appeared. The field included nerve fibres and deeply stained small round nuclei that are not introduced in the drawing; another part of the field contained the arteriole and its capillaries, as shown in figure 2.

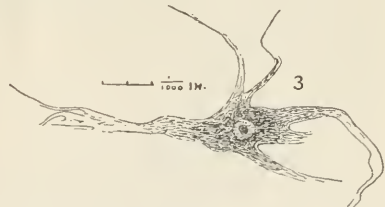

The effect for display of cell structure can be gathered from figures 3, 4, and 5. In figure 3 I have shown the cell in the upper left-hand corner of figure 1, as seen under a one-twelfth inch oil immersion lens. The cell does not show all of the points that are known to be characteristic of the multipolar cell from this situation. Thus, the method does not distinguish any pigment, nor is the axis-cylinder process distinguished from the branched protoplasmic processes, one only of which is seen to branch. But the fibrillation in the protoplasm, "running in different directions through the cell," is beautifully shown, as well as the single elements of the fibrillation, which appear as very narrow and long, deeply stained particles in a lighter ground, which also stains. The nucleus and the nucleolus

are also admirably brought out. The capillary and arteriole also offer remarkably good opportunity for the beginner, for the nuclei of the endothelium in both, and those of the un-stripped muscle tissue in the arteriole are superbly shown, and the relations of the vessels, their relative sizes, and such points, are well given. I hardly know of a more available method for getting vascular tissue for simple elementary study.

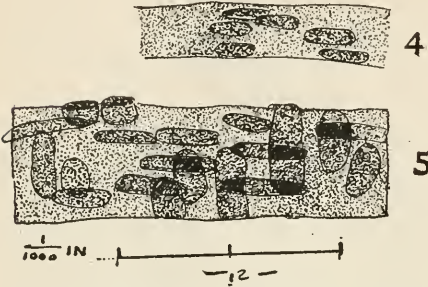

The advantage which this method offers is its ready and quick application. All other isolation methods, as of soaking in weak alcohol, involve at least one day, if not several days, of preparation, while with this method one can use material obtainable on the spur of the moment and complete the process inside of a couple of hours. Like all rough and ready methods, it has its drawbacks; still, considering the distance it takes one on the road to a complete knowledge of the nerve ganglion cell, I think it deserves consideration.

Biological Laboratory, Hamline University, Dec. 11, 1897.

Agar.

As the process of making agar given in text books on bacteriology and bacteriological technique is unnecessarily tedious, and as it not infrequently happens that precipitates make their appearance in the tubes after sterilization, although the product appeared to be clear when filtered and run off into the tubes, a modification of the process which obviates the formation of secondary precipitates and at the same time lessens the time required for making agar, will doubtless be of interest to those who still employ the old process. After numerous efforts to devise a satisfactory method, I have finally adopted the following, by which a very clear agar, in which no secondary precipitates appear, can be made in a comparatively short period, the whole process if properly managed being completed within two-and-a-half to three hours:

Pour a liter of water over a pound of finely minced lean beef and allow it to simmer over a slow fire for half an hour; then boil for fifteen minutes and filter through paper. Rub up ten grams of powdered agar in a little cold water, gradually adding more water until all of the powdered agar has been moistened and the mixture made thin enough to readily pour out of the dish (consistency of thin mucilage); stir this into the filtered meat-infusion and place it on the fire to boil in a porcelain lined saucepan. In like manner rub up five grams of sodium chlorid, and ten grams of Witte's peptonum siccum (dry peptone), in a little cold water and stir this into the mixture; boil until the agar and peptone are dissolved, which requires usually about ten minutes; now remove from the fire and carefully neutralize, preferably with caustic soda; make up the bulk to one liter and transfer to flasks. The flasks are now placed in the steam sterilizer, sterilized for twenty minutes and then allowed to remain in the sterilizer with the flame turned low until the precipitate thrown down by heat and the insoluble particles have separated and subsided; the clear supernatant fluid agar is now syphoned or carefully poured off and run into tubes, while the turbid portion is reheated to the boiling point, preferably in the steam sterilizer, and filtered through folded filter paper, of coarse mesh, which has just been moistened with boiling hot water. Should the clear portion become slightly clouded by inadvertently pouring a little of the sediment into it so as to require filtration, it will be necessary to reheat this also before attempting filtration; but it is best to keep it separate from the more turbid portion as it will filter much more rapidly, being comparatively free from flocculi, the tendency of which is to clog the filter.

By this method the use of the white of egg for clarifying is rarely if ever necessary, and if proper filter paper is used filtration is quickly and readily accomplished without the use of hot water funnel or other means of keeping the mass hot. It is the sterilization and spontaneous separation of the coagulated and insoluble particles (including the phosphates thrown down by heat) which obviates the appearance of secondary precipitates and does away with the necessity of clarifying, while the decantation of the larger part of the mass, which has thus become perfectly clear, reduces the bulk of the mass requiring filtration to such an extent as to enable the turbid portion to run through the filter before it has had time to cool enough to thicken in the filter.

The process can be still further short-

ened by using twenty cubic centimeters of Valentine's meat juice instead of making the meat infusion as above indicated. I specify Valentine's, as it makes a meat infusion of lighter color than any other meat extract that I have tried, and consequently a clearer and lighter colored agar, equal in this respect, indeed, to the agar made in the regular way.

W. W. ALLEGER.

Howard University, Washington, D. C., Dec. 6, 1897.

Class Technique in Pathology.

ERNEST B. SANGREE, A. M., M. D.,

Professor of Pathology and Bacteriology in the Medical Department of Vanderbilt University, Nashville, Tenn.

Since much of the work in a pathological laboratory is essentially mechanical, it is important in order to get the full benefit of the laboratory period, that the mechanical portion should be executed in as speedy and systematic a manner as possible. In the rather limited time usually allotted to this subject, it does not seem possible to have the students do much of the section cutting themselves. They are so very unequal in mechanical ability, the majority poor, that the results are likely to be bad. Good mounts require thin sections, and it is, therefore, my custom to have the blocks of tissue hardened, embedded and cut by my assistants. Celloidin is preferred for class work, for in this way I can have three or four hundred sections cut months before hand and allowed to stand away in bottles against the proper time. Our sections are usually cut about twenty micromillimeters thick, and on account of the enveloping celloidin matrix, these sections can be handled by the students as easily as naked sections three times as thick.

Before the hour, the sections for the day are put in wide, flat dishes of water in the laboratory, and each student takes a section in a watch glass of water to his desk. I think that double staining by logwood and eosin is by far the most satisfactory routine method for class work. For clearing I prefer creosote. It must be the best beechwood. This seems to take up more water in less time than any other medium. Neither does it dissolve the celloidin matrix nor extract the eosin. But the most important part of laboratory teaching is the demonstration. Everything else is subsidiary to that. Of what use is a beautifully mounted specimen unless the student understands it? Students at the microscope require individual attention, yet when there are forty or more in a class, it becomes physically impossible

to spend much time with each one. What answers the purpose nearly as well, however, is the microscopic projection apparatus. We have such an attachment to our electrical lantern. At the beginning of each lesson, the sections for the day, previously stained, are thrown on the screen by means of the 3-4 and 1-4 projection objectives. These objectives give images sufficiently clear and well-defined so that everyone in a large room may see. Since the section appears on the screen exactly as it will under the individual microscope, ten or fifteen minutes spent in this way in pointing out the elements of the specimen are almost equal to the same time spent on each instrument. Further to facilitate actual microscopic demonstration, I have had placed half way across the eyepiece diaphragm of each microscope a human hair to act as a pointer. As this is in focus along with the specimen, any object which it is desired to point out to the student can instantly be brought to the end of the pointer by moving the slide, and he cannot fail to see it. Only those who have had much experience with microscopic demonstration know how prone the student is to see anything and everything in the field but the particular point one is calling to his attention.

By pursuing this plan, briefly outlined, it seems to me that we get from our students what ought to be considered as satisfactory results in this branch of their general work.

APPARATUS.

[Translation from Central-Blatt f. Bakteriologie.]

A New Filtering Apparatus.

From the Hygienic Laboratory of the University of Michigan, Ann Arbor, Mich.

DR. F. G. NOVY.

Although various bacteria filters have been described, it may not be without value to present a piece of apparatus which has been in use in this hygienic laboratory for some time. Besides its cheapness and simplicity, it has the advantage that the positive pressure of compressed air and the negative pressure of the exhaust pump act simultaneously on the fluid which is to be filtered. Figure 1 shows the complete apparatus.

The important part of the filter consists of a glass cylinder, 20 cm. long, having throughout its entire length an internal diameter of 3 cm. At one end there is a spherical enlargement of 250 or 500 ccm. capacity, which is provided at its upper end with a neck of about 2 cm. diameter. The other end of the

cylinder is provided with a flange 7 cm. in diameter. The bearing surface of the flange is 2 cm. wide and 1-2 cm. thick, and is ground.

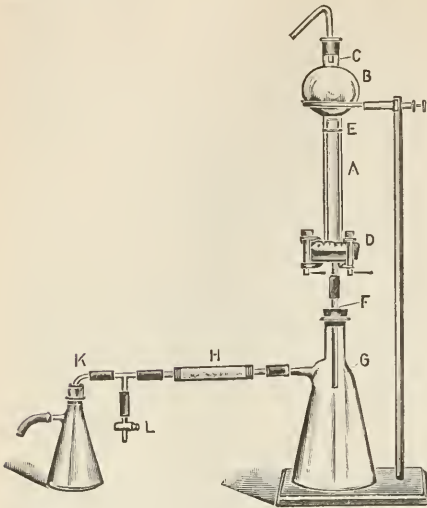

Fig. 1.

The upper and lower surfaces of the flange must be parallel or nearly so, in order to prevent the clamps from sliding off. In the construction of the cylinder it is essential that the ground surface be at right angles to the inner wall of the tube, and besides, that the inner diameter of the tube be uniform throughout. Should the tube be but very slightly narrower near the flask, it would not permit the introduction of the filter tube (Chamberland-Pasteur). In addition to this, the cylinder must be made of thick, strong glass, in order to withstand a pressure of five or more atmospheres.

cylinder with the flange end uppermost on the ring of a retort stand. A rubber ring (fig. 2, 1) is slipped over the sterilized filter-tube, and the latter is then placed in the cylinder. When pressure is afterward applied, this ring makes a perfect connection between the filter-tube and the cylinder. If, however, the ring is of soft rubber, the filter-tube is liable to be broken on account of the high pressure. Ordinary cloth-covered rubber, from which the cloth has been torn, answers the purpose very well.

A similar rubber ring (fig. 2, 2) is slipped over the neck of the filter-tube, then the thick rubber ring (fig. 2, 3) is placed in position, and, lastly, the brass-plate (fig. 2, 4). Then the whole is clamped tightly together by means of three screw-clamps such as are used with my Anaerobe Plate Apparatus. The clamps must be tightened gradually and equally in order to prevent the lower closed end of the filter-tube from being forced against the sides of the cylinder. It is advisable to place on the closed end of the filter-tube a very thin rubber band, as shown in (fig. 1, e), which will serve as an index of the lateral pressure.

The thick rubber ring (fig. 2, 3) may be replaced by small pieces of rubber of the same thickness as the ring. The rubber stopper, glass tube, and short rubber tube (fig. 1, f.), having previously been sterilized by steam, are now connected with the filter-tube, and the entire apparatus inverted and connected with the sterile receiving-bottle (fig. 1, g). This bottle is connected with a tube (fig. 1, h) filled with sterilized cotton or sand, and the latter with a small bottle (fig. 1, k) for taking up any back flow from the pump. A glass cock (fig. 1, l) is provided to facilitate the admission of air.

As is well known, there is a great difference in porcelain filters in regard to rapidity of filtration; usually 250 cc. of water can be filtered with the help of a pump from three to five minutes. Bacterial fluids of course filter much slower, especially if they have not been first filtered through paper. If the flask containing the fluid to be filtered is connected with a cylinder containing air under a pressure of four or five atmospheres, this positive pressure can easily be added to the negative pressure already present. In this manner thick fluids, even blood serum are easily and rapidly filtered.

The small air cylinders with pumps, such as are used by physicians for spraying purposes, are very well adapted for this purpose. Similar cylinders of compressed air, as used for inflating bicycle tires, answer the same purpose. Before the pressure is applied, the stopper in the neck of the flask is fastened down securely by means of wires to the ring

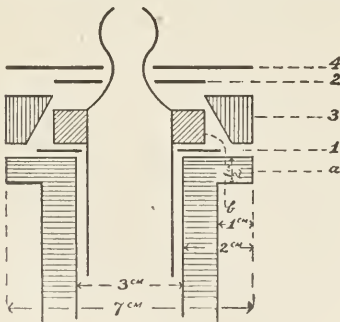

Fig. 2.

Figure 2 explains the device for obtaining a perfectly tight connection between the shoulder of the filter-tube and the flange of the cylinder. When putting the parts together, it is best to place the

on the stand. A brass plate with suitable incisions is placed over the stopper to prevent the wires from cutting into it.

As a safeguard against possible imperfections in the glass, it is advisable before applying the pressure to cover the entire apparatus with a suitable box.

The described glass cylinder can be procured from Greiner & Friedrichs, in Stutzerbach, Thuringia, for about two marks.

An Improved Paraffin Imbedding Dish.

The ordinary paraffin imbedding box made of a glass plate and two small metallic L's, is very deficient for practical work. This is especially true when large quantities are to be imbedded for class use or for special investigation. Petri dishes 80, 120 and 150 millimeters in diameter, answer the purpose quite well, as large cakes containing many pieces of tissue can readily be made in them; but when using the petri dish, it is often difficult to remove the paraffin cakes, especially if the walls of the dish are not perfectly regular. The dishes are also easily broken and the bottom cannot be removed so as to secure more rapid congealing of the paraffin.

In order to secure the advantages of the petri dish and at the same time avoid the disadvantages mentioned above, I have devised a paraffin imbedding dish which I think will be found very convenient. (Fig. 1.) The bottom

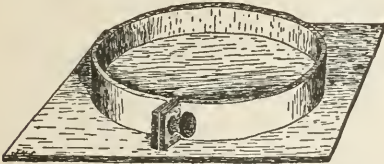

Fig. 1.

is a square glass plate of proper size and thickness, while the box consists of an open brass ring with a thumbscrew. The sides of the ring should be smooth and should be of sufficient thickness to secure rigidity. About two or three millimeters is the proper thickness. It will be found most convenient to have the rings of three diameters, 80, 120 and 150 mm. Before imbedding, apply a very thin coat of glycerine to the parts with which the paraffin will come in contact and pour in a suitable amount of paraffin to make the cake. The objects should be in a bottle with a cork. Turn the bottle upside down and allow the objects to settle on the cork. Then remove the cork and let the paraffin in the bottle with the objects fall into the dish. The objects may be arranged in the paraffin

with hot needles. Put the dish quickly into cold water, but do not let the water flow into the dish until the paraffin is hard enough to bear the weight of the water without being distorted. In a short time the glass plate may be removed, thus permitting the under side of the cake to cool more rapidly. After the cake is thoroughly hardened it can easily be removed from the brass ring by loosening the thumbscrew.

JOHN H. SCHAFFNER.

Botan. Laboratory Ohio State University, Dec. 3, 1897.

DISCUSSION.

Papers upon live subjects within the province of the JOURNAL will be printed over the author's signature.

The Microscope in the High School.

The most important pedagogical advance which has been made in science teaching in high schools during the last decade is unquestionably the introduction of laboratory methods in the biological studies. Begun in the largest and most progressive high schools, the new method has now been adopted by all but the least progressive teachers. In botany, zoology and physiology, the study of definitions, systematic descriptions and detailed accounts of how organisms look and act, have been subordinated to the direct observation and study of the organisms themselves. Each student now sees for himself the fact which he hitherto has only read about in his text-book. Science has come to be taught as science, rather than as literature. The student has become an original investigator in place of a mere memorizer of descriptions. Now, his faculties of observation, judgment and description are trained and developed, where formerly only his memory was cultivated. This change in the method of teaching has necessitated a change in the means of its application. The text-book is now superseded by and made secondary to, the specimen itself. The latter is more thoroughly studied and more frequently consulted than the former. Just as the laboratory study of physics, as contrasted with the ancient text-book method of studying the subject, has made necessary an elaborate equipment of apparatus for experiment and for the demonstration of physical laws, and just as modern methods of teaching chemistry require that the student shall have all the appliances needed by the practical chemist and investigator himself, so in the biological sciences the microscope and the scalpel and for-

ceps have become indispensable to both teacher and student alike.

The foundation of all true conceptions of the structure and functions of the bodies of plants and animals rests upon a clear understanding of the structure and functions of cells, and since the latter are far too minute to be studied with the naked eye, it is needless to say that all study of anatomy and physiology of animals and plants must necessarily include a thorough examination of their tissues by the aid of the microscope. No clear idea of the structure of muscle, nerve, bone, cartilage, secreting cell, animalcules, lower cryptogamic plants, pollen grains, etc., etc., can be obtained by reading only. The objects must actually be seen. Once seen and carefully examined they are rarely if ever forgotten. The boy who has studied with a microscope knows that a cell is something more than "a circle with a little circle in it, containing a dot." None but a boy brought up on text-books would define the object in those words. It is safe to say, that there is no first-class high school in the country which has not its outfit of microscopes. There are still some teachers, however, who have failed to keep abreast of progress and are still making the text-book, rather than the specimen, the chief source of knowledge. Some of these do not care to better their work, others, even though they could have instruments for the asking, stand in awe of the microscope, and fear that they may damage the instrument irreparably if they try to handle it, while still others, anxious beyond measure to adopt the best methods of instruction, find themselves hampered by the ignorance and whims of principals, superintendents and school boards. The remedy for the first class of teachers is either to force them into the adoption of correct methods of teaching or to dismiss them and supply their places with more intelligent and progressive successors. Teachers included in the second class will be surprised to find how easily and quickly they can learn the simple technique required for such work as they will have to do. High school pupils learn in two or three exercises all that they need to know about the use of eyepiece and objective, mirror and diaphragm, coarse and fine adjustment, illuminating the object and finding the focus. Why cannot the teacher do the same? The instructor, whose superiors are ignorant or unappreciative of the needs of his department, can do nothing better than to enter upon a campaign of enlightenment, and to insist upon every possible occasion upon the necessity of having an equipment of microscopes. In the course of time, persistence will as certainly win

in this case as it has in many similar ones, and the desired instruments will be purchased. In this day of cheap and durable microscopes, when as good an instrument as the pupil needs can be bought for from \$18 to \$25, there is no excuse whatever for any high school being without an outfit. If it is impossible to supply each pupil in the class or section with a separate instrument, there ought at least to be one instrument, by means of which minute structures and organisms can be exhibited to the pupils individually. Too often in the past, and in some places it is still so, has the microscope been left in the department of physics where it is studied (if at all) as a means of illustrating certain principles of optics. Its proper sphere is that of an instrument of research, a means to an end and not the end itself.

The microscopes having been obtained, it becomes necessary to have the specimens properly prepared before they can be examined. This is after all in many cases a very simple matter, consisting merely of putting the object on the slide in a drop of water and covering this with a cover glass. In other cases good specimens, as many of the tissues of the body for example, are obtainable only by special methods of preparation, involving perhaps, fixing, hardening, imbedding, sectioning, and mounting in some special manner. These methods are, of course, familiar only to the trained histologist. Nevertheless, specimens prepared in this manner can now be obtained at very small cost from dealers in microscopical supplies and a single set will last indefinitely, if properly handled, for the specimens are so mounted as to be permanently preserved. Teachers of zoology, botany and physiology can now easily and cheaply procure all kinds of specimens their classes are likely to need. Hence, there is no excuse for a teacher going without a microscope, either on the plea that he does not know how to handle it, or that he is not familiar with the modes of preparing specimens. Nor on the other hand can school boards plead expense as an excuse for not giving the high school a good equipment, for the initial cost is very small per microscope and the instruments will last for a generation or longer if properly handled and not abused.

CHARLES WRIGHT DODGE.

University of Rochester, Dec. 2, 1897.

An early number of the Journal will contain an article on Mitosis, illustrated with photo-micrographs.

Journal of Applied Microscopy.

Issued Monthly from the Publication Department
of the Bausch & Lomb Optical Co.,
Rochester, N. Y.

L. B. ELLIOTT, EDITOR.

Address all communications to
PUBLICATION DEPARTMENT,
BAUSCH & LOMB OPTICAL CO.,
ROCHESTER, N. Y.

Entered at the Post-office, Rochester, N. Y., as second-class matter.

JANUARY, 1898.

EDITORIAL.

Raison d'Être.

Specialization is the order of the day, and the specialist has time for his particular specialty only. It is thus necessary for every branch of science, art or industry to have its own particular medium for the collection and speedy dissemination of information essential to its development. It seems almost unaccountable that in America, where the microscope and apparatus accessory to it is so extensively used in educational and industrial institutions, there should be no periodical devoted to microscopical instruments and technique viewed from a practical standpoint. Such is nevertheless the case, and such writings as are given to the public are either scattered through a variety of publications properly dealing with other subjects, reports, bulletins or the microscopical journals of foreign countries, of which there is an abundance, liberally and well supported. Believing therefore that there exists a demand for such a publication, the *Journal of Applied Microscopy* is presented to the users of microscopes, with the statement from the publishers that it will be conducted on an entirely independent basis, beginning in a very modest way, but with the promise that it will be expanded in direct proportion to the support received from those engaged in practical microscopical work. In other words, it is intended that the *Journal* shall be just what its contributors and supporters make it. It will be a progressive record of new apparatus of every kind bearing on the operations leading up to and including the use of the microscope, improvements in apparatus and new applications of

apparatus already existing, methods of working, new and useful formulae, discussion of matters relating to the above subjects, digests of similar matter appearing in foreign journals, and news and notes about institutions and men here and abroad. We realize that the success of the *Journal* depends upon the support of those interested in the advancement of the practical side of science, and trust that all will take advantage of the opportunity here presented to build up a representative American publication for applied microscopy.

* * *

Magnifying power, in the minds of many persons, seems to be the aim and end of the microscope. This opinion prevails with many possessors of microscopes, although it is most common with the laity. A highly sensational and ludicrous article on a new method to obtain this result appeared in a New York newspaper some time ago and went the rounds of the press of the country. The mischief done by one such article can never be entirely obliterated, but in order to counteract its influence as much as possible we shall recur to the subject in a later issue.

Magnifying power, as a quality in itself, is valuable only so far as it discloses what we wish to see. Any increase of power beyond this, is of no value whatever. Microscopic vision depends upon the resolving power, and this in turn upon the angular aperture, of the objective. Resolving power alone is of no value. The image created by the objective must be magnified to such an extent as to make the detail we are looking for visible to the eye, and an increase in power simply separates the detail; if this proceeds too far it reduces the definition and light.

When we say that resolving power depends upon angular aperture, it is of course assumed that the objective is a typical one, that the chromatic and spherical aberrations are properly corrected, and that it is properly constructed mechanically.

We know what each additional degree of angular aperture will give in resolving power, as well as the limit of visibility with the greatest angular aperture, and there is no hope of obtaining more detail by the mere increase of power.

* * *

A cordial invitation is extended to those who have worked out practical methods, to give their fellow workers the benefit of their researches in the *Journal*. A simple, certain method of arriving at a definite result is always of service. The description of the method

should, however, be complete and leave nothing to be determined by experiment, and should not assume the reader to have previous knowledge of any part of the process vital to the final result. The use of the microscope as an aid to modern science and the industries has advanced so much faster than the literature of technique, that a large proportion of the most valuable methods are confined to the laboratories in which they originated and are to be learned of only by personal inspection or correspondence. For this reason many seemingly commonplace subjects need a careful writing-up by the specialist in that department for the benefit of the many whom time or opportunity has prevented from working out a good method for themselves.

* * *

It is hoped that the correspondence department will be freely made use of for the purpose of criticism and inquiry. Criticism of matter appearing in the Journal and inquiries regarding subjects not touched upon will be particularly in order.

TRANSLATIONS.

[Translation from Cent. f. Mikros.]

Buege: On the Examination of Milk for Tubercle Bacilli.

Halle a. Salle, 1896.

To demonstrate the presence of tubercle bacilli in milk (Martmilch) Buege, who worked under the direction of C. Frenkel, centrifugated it in a Gerber hand centrifuge (two tubes together containing forty-nine cc. for each sample), then mixed the cream and sediment (in both of which, according to Scheurle, tubercle bacilli are found) which had been taken out with a sterile pipette, into sterile dishes and injected from each sample two Guinea pigs, each pig receiving intra-peritoneally five cc. In this manner nine samples were examined. In three animals which were injected from two of the nine samples, the presence of tubercle bacilli in the milk was demonstrated. A number of the animals died early of peritonitis and were consequently lost to the experiment. The author thinks that perhaps these deaths resulted from the bacterium coli, which, according to Rottig, occurs almost always in the milk in Halle. It might perhaps, says the author, therefore be advisable to use only the cream in future for such examinations, as the bacterium coli is thrown out of it (during centrifugation) whereas the tubercle bacilli remain in considerable numbers. As this

animal infection method has many disadvantages, namely, that it does not permit of sufficiently rapid diagnosis, the author tried direct microscopical examination according to the methods of Biedert, Spengler, and Schrank. With these methods it was not difficult to detect even minute numbers of tubercle bacilli which had been purposely added to the milk. In applying these methods to milk (Martmilch) it was not possible to prove the presence of tubercle bacilli, although as stated above, the test with animals gave positive results.

(The centrifugal examination of milk and sputum for tubercle bacilli is one of increasing importance and we should be glad to receive notes regarding apparatus, methods, and speeds giving the best results.—Ed.)

SUGGESTIONS.

Investigators are requested to report new formulae, stains, reagents, etc., for publication in this department.

Necturus is one of the very best subjects for class demonstration of the various tissues. The cells themselves are so very large and their arrangement so simple that students are able to comprehend the primary structures much better than when more highly organized subjects are used. Necturus is widely distributed, and specimens are easily obtainable in the spring and may be kept alive the year around if desired, or preserved in the usual preservatives.

NOTICES AND REVIEWS

We shall be glad to notice all books, papers, reports, bulletins, periodicals, etc., within the scope of the JOURNAL, which are sent to us for that purpose.

The report of the Secretary of Agriculture for 1897 is before us and contains an interesting review of the work of the past year, including much statistical information. One million, eight hundred and eighty-one thousand, three hundred and nine specimens of pork were microscopically examined, 13,325 of which were found to be infected with trichinae. The cost of inspection was 0.256 cent per pound. The secretary recommends that the cost of the inspection be in future assessed against the trades benefitted, as the funds at the command of the department are inadequate to maintain a thorough inspection with the increase in the demand for it. "If the packers paid the cost of inspection, there would be no longer any reason for declining to extend it to all who apply for it."

Journal of Applied Microscopy.

VOLUME I.

FEBRUARY, 1898.

NUMBER 2

Methods of Study of the Myxamoebae and the Plasmodia of the Mycetozoa.

HOWARD AYERS, Ph. D.

Professor of Biology, University of Missouri.

GEOTROPIC, HELEOTROPIC, CHEMOTROPIC, THERMOTROPIC, MECHANICAL AND ELEC- TRICAL STIMULI, AND THE EFFECTS OF THE REMOVAL OF CAP- ILLARY WATER.

For the study of the problems of irritability of protoplasm, the plasmodia of the Mycetozoa afford exceptionally fine material, mainly on account of the large size of the protoplasmic masses at the disposal of the investigator.

For the study of the geotropic reactions, it is necessary to have the cultures so envired that the reactions to light, warmth, currents and chemical substance shall be excluded. The importance of these precautionary methods is well understood by all, for some other stimuli are much more powerful in their effect upon the plasmodia, than the geotropic, e. g., the rheotropic and thermotropic. Some of the thermal reactions require explanation, as, for instance, the migration of the protoplasm away from areas of cooling, and consequent condensation—a mass movement which thus takes place in opposition to other physical forces. This phenomenon may be studied under the microscope in the following way: the microscope is so arranged that on one side of its stage a warm stage is placed and kept at a temperature of 75 degrees to 80 degrees F., while on the other side, separated by a space of 3-4 inch, a cold stage is placed, kept at a temperature of 40 degrees there. Upon these stages the ends of a glass slide, covered by the glass box to prevent evaporation, is placed and the plasmodium, which should have extended itself over the whole extent of the slide, is studied. It will gradually be seen to collect upon the end of the slide resting upon the warm stage.

For the study of heleotropic reactions,

the glass box may be replaced with a light wooden box impervious to light, with a window in its top, which may be closed light tight or be opened for observation. The glass slide is to be replaced by a wooden plate or a thin glazed tile of suitable size—metal and rubber plates are objectionable—and care must be taken to free the wooden plate from possible chemitropic influence. If it is desired to expose the plasmodium to light rays from several directions, the glass box may be used covered with black paper in which windows may be cut at pleasure or closed by means of gummed labels cut out of black paper.

THE EFFECTS OF THE REMOVAL OF CAPIL- LARY WATER, OR HYDROTROPISM.

The reactions of plasmodia to a varying supply of water can be easily studied on small plasmodia on a glass slide provided with a glass box made of cover glasses, by cementing the edges of the thin sheets together with marine glue, leaving a drop of glue in each corner to serve as a brace and to more effectually hold the glasses in position under pressure. Such a box may be provided with a hole in the top glass, which may be sealed at any time with a common cover glass smeared with vaseline (glycerine is objectionable in such experiments). If the box has an unbroken top, it may be raised over the slide by small strips of glass slide placed under each, or only one end as desired, and in this way the gradual evaporation of water may be secured under observation. If a plasmodium is transferred to a slide covered with filter paper wet in water and one end of the glass box be coated with a layer of gelatine, the opposite being raised from the slide, the plasmodium will be found to retreat towards

the closed end as evaporation proceeds and to ultimately climb up onto the gelatine surface to escape the evils of drying.

POSITIVE HYDROTROPISM.

If now the plasmodium is about to fruit, it will be seen to quit the gelatine surface and seek the dryer parts of the filter paper or perhaps flow out onto the exposed and dry surfaces of the slide before rounding itself into sporangia (negative hydrotrophy). On a large scale hydrotrophy may be demonstrated by placing large pieces of wood containing plasmodia in battery jars with a few inches of water in them and covering the jars with a window pane or other close fitting glass cover. When ready to fruit the plasmodium will squeeze itself through between the edge of the jar and glass plate and form sporangia on the outer surface of plate and jar. At times so strong is the reaction that strands of protoplasm may be seen to erect themselves in the air several millimeters in search of the source of water vapor.

Hydrotropism, if not a form of chemotropism, is certainly closely related to it, and the motile forms of the mycetozoa lend themselves to the most varied experiments in the latter field. By the addition of any chemical substance to the moistened filter paper upon which a plasmodium is resting in such a culture box, as described above, the positive or negative reaction may readily be observed in the advance or retreat of the migrating protoplasm. Solutions of tar, sugar, salt, extracts of decaying wood and leaves, glycerine and any of the laboratory reagents may be tried with success.

In the experiments with minute plasmodia and myxamoebae, capillary glass tubes, partially filled with reagent to be tested, may be mounted under the cover glass along with the organisms. The air space which is left in the tube should be at the closed end. If it is desired to study the reaction of the larger plasmodia under high powers, it will be necessary to substitute a coat of gelatine in the moist chamber for the more easily prepared strip of filter paper. Though a number of slides may be quickly coated with gelatine and stored away in a slide box for future use, all that is necessary to get them ready for use is, to soak them in water before transferring the plasmodia to them. The transparent layer of gelatine will not detract from the value of the preparation for high power work.

The chamber described above may be used as a drying chamber and a gas chamber by cementing a piece of small

glass tubing into suitable openings made in opposite corners of the box, and connecting one tube by means of rubber tubing with a dry air or gas supply, while the other tube is left for the exit of the reagent. In this way and by the use of the filter paper and gelatine substrata, experiments in the immunization of the plasmodia against any toxic substance may be readily conducted.

Much remains to be done in the field of electrotrophy in its broadest sense, and the careful study of the action of the induction current on protoplasm, e. g., a plasmodium, will surely lead to a much better knowledge of the relation of protoplasmic structure to electrical energy. The gradual yet complete disintegration of particles of protoplasm in the immediate vicinity of other particles which survive, offers an exceptional opportunity for new discoveries in the nature of vital organization.

Mechanical stimuli are readily applied to plasmodia and the reactions are direct and not in any way interfere with, and the results of shaking, tearing, cutting, crushing, mixing with various solid and liquid bodies are easily effected either upon the slide or in a test tube.

THE PREPARATION OF MICROSCOPIC MOUNTS OF PLASMODIA AND MYXAMOEBAE. KILLING REAGENTS.

Whole Plasmodia of any of our common mycetozoa make extremely interesting and valuable microscopic preparations illustrative of the forms assumed by naked protoplasmic bodies and of the structure of protoplasm, which field is still almost untouched. Besides, there is the very important line of investigation dealing with the chemico-physical constitution of protoplasm, which may be studied by means of micro-chemical tests made on the myxamoebae and young plasmodia, as well as the mature and fruiting plasmodia.

Plasmodia which have been transferred to slides and thus been freed from sand grains and other impurities which might interfere with microtomic manipulations, are fixed in any desired way. Any of the usual fixing and killing reagents will furnish good material, but, of course, here, as elsewhere, the selection of the reagent will depend upon the result desired. The following reagents give the best satisfaction, in the order named:

KILLING REAGENTS.

Merkel's Fluid.
Osmic Acid Vapor.
Formalin, 10 per cent.
Hot Formalin, 5 per cent.
Picro-Sulphuric Acid.
Picro-Formalin.
Formal-Acetic.

And the following staining reagents have proven most satisfactory:

Ranvier's Picro-Carmine or Mayer's Carmalum, for a carmine stain.

Safranine.

Acid Methyl Green.

Ehrlich Biondi Mixture—for an aniline stain.

In case safranine is used, the procedure should be as follows: Plasmodia hardened, or at least fresh from 90 per cent. alcohol, are placed in the staining solution, overstained and then decolorized in 80 per cent. alcohol until nearly ready to mount, when they are transferred hastily through absolute alcohol to clove oil, which completes the extraction of color, and from this they are mounted in balsam.

Another procedure is as follows: From the decolorizing 80 per cent. alcohol, they are transferred to a mixture of 1-3 each of carbolic acid, bergamot and cedar oils, and from this into balsam.

SECTIONS OF PLASMODIA AND SPORANGIA.

After killing, fixing and transferring to the permanent bath of alcohol or formalin, plasmodia are ready for imbedding and they give excellent preparations by both the paraffin and celloidin methods, but I much prefer the latter procedure on account of the more natural condition of the protoplasm when it finally comes under the lens for study.

There is no difficulty in getting suitable masses of the mature and fruiting sporangia forming plasmodia for study, but sometimes it is not easy to get the young plasmodia in large enough masses for satisfactory sections. Young plasmodia may be coaxed to heap themselves up into cavities in filter or blotting paper by wetting the paper with nutrient solution, and forming it into suitable thimble or cup shaped receptacle it may be dropped into any of the killing and fixing media and good preparations secured.

Serial sections may be treated with different stains, a slide at a time, and the results of different reagents thus observed upon the same mass of protoplasm.

MYXAMOEBAE.

The very young or incipient plasmodia and the myxamoebae should be treated with the methods employed in the study of rhizopoda. They may be collected in numbers in watch glasses or in culture cells and killed in loco, or transferred to slide covered and treated with the required succession of reagents by means of the washing apparatus shown in Fig. 1.

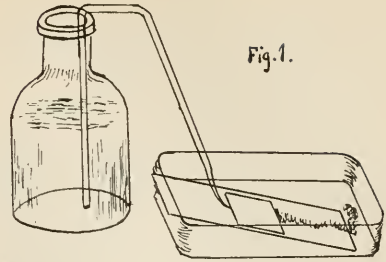

Fig. 1.

A METHOD OF QUICKLY AND ACCURATELY MARKING THE POSITION OF AN OBJECT IN THE FIELD.

With a Ring of Varnish.—The position of particular nuclei, granules, food vacuoles or any object whatsoever may be quickly marked upon the surface of the cover glass with a ring by attaching to the end of the object glass a collar bearing a centered ring as shown in Fig. 2. If a

Fig. 2.



triple or quadruple nosepiece is attached to the microscope it will be found convenient to use one opening for a blank objective provided with such a marker. The microscope tube is lowered until the ring deposits a thin layer of varnish on its lower edge upon the cover glass.

With a Minute Dot of India Ink.—For many preparations it is preferable to mark the positions of the objects elected by a small black mark such as may readily be produced by having a needle or quill point mounted in the center of such a collar as mentioned in the last paragraph. The ink is applied by means of a quill or brush which comes in all bottles of the fluid, and the microscope tube is then lowered until the point deposits the small dot of ink.

With a Triangular Paper Label.—If it is desired to use a white mark, minute triangles of paper may be cut and placed upon a very small drop of mucilage or balsam which has been placed upon the cover glass by means of the point used for marking with ink. When the fixative is dry, such white labels serve to mark the position of objects very clearly. The ring should be made of light spring brass, as the whole instrument may be made from one piece.

A Method of Preserving the Eye for Sectioning, or for Demonstrating the Area of Acute Vision.

JAMES ROLLIN SLONAKER, Ph. D.,
Instructor in Zoology, Indiana University.

In order that the eye may be well preserved it must be placed, as soon as possible after death, in Perenyi's fluid.

10 per cent Nitric acid, 4 parts.

95 per cent. alcohol, 3 parts.

0.5 per cent. Chromic acid, 3 parts.

The eye should be carefully oriented before removing from the head by sewing a tag to the outer layers of the sclerotic, so that the orientation may afterwards be exact. In removing the ball it should not be punctured, for this invariably causes wrinkling of the retina. As much as possible of the fat and muscle should be removed before immersing it in the Perenyi. The bulk of the preserving fluid should be ten or fifteen times the size of the eye.

The time that the Perenyi should be allowed to act depends on the size of the eye and the nature of the sclerotic. Small eyes, as rat, sparrow, etc., are usually left in 24 hours and large ones, such as cow, horse, or those in which the sclerotic contains bony plates, 36 to 48 hours are required. A good deal of latitude may be taken, however, regarding the time.

After the action of Perenyi's fluid the eye is carried up through the following grades of alcohol, leaving it 24 hours in each: 70 per cent., 80 per cent., 90 per cent., 95 per cent., 100 per cent., and finally a mixture of equal parts of absolute alcohol and ether. It is then well hardened and ready for celloidin imbedding. Before putting into celloidin a window is cut in the same plane as the desired sections exposing the hardened vitreous humor. After this is carefully removed without injury to the remaining structures, the hollow ball is put into celloidin. I have used three grades of celloidin, ranging from very thin to very thick, and have left the eye at least 48 hours in each. It can remain longer with better results. It is then mounted on a block in the usual manner and cut in 80 per cent. alcohol.

I have not succeeded in securing good sections of the whole eye by imbedding in paraffin, since the lens becomes almost flinty and prevents sectioning.

If one desires only to demonstrate the fovea and not to make sections, the front half of the eye may be cut off after passing through the 80 per cent., but preferably after 95 per cent. alcohol. When thus removed, together with the vitreous humor, the retina is seen spreading

smoothly over the posterior half of the ball and the fovea, if present, and the optic papilla may be easily seen. Such demonstration material can be kept permanently in 80 per cent. alcohol.

This method applies only in a gross study and can not be used successfully for the minute structures of the retinal elements. If such is desired the Golgi method as used by Ramon y Cajal (†), or the "Methyl Blue" method (‡) will admirably serve the purpose.

† Ramon y Cajal. *Retina der Wirbelthieren*. Uebersetzt und herausgegeben von Richard Greeff.

‡ A. Dogiel. Ueber das Verhalten der nervösen Elemente in der Retina der Ganoiden, Reptilien, Vogel, und Säugethiere. *Arch. f. mik. Anat.* Bd. xii.

DISCUSSION.

Papers upon live subjects within the province of the JOURNAL will be printed over the author's signature.

Photography in the Biological Laboratory.

W. H. MUNSON.

Workers in all lines are earnestly seeking short cuts to final results, and among these none are more earnest in their endeavors than are biologists; and especially they who have diversified work in this subject, or are hampered by the necessity of devoting much time to other subjects.

Many such an one, overworked during the year, has put in a part or all of the summer vacation in studying nature from the standpoint of the artist, having as his constant companion the inevitable hand camera of some sort or other. If he has gotten the most pleasure and profit possible in his study, he has developed and printed his own pictures, thus, in a large measure, preparing himself for a kind of work that may be made to facilitate his own efforts, and largely increase the interest and profit of his pupils. If, instead of being a teacher in a high school this particular camera-fiend is in charge of college classes in general biology, in zoology, or in botany, he can still make very good use of his acquired skill in photography. If he is largely engaged in research on cytological lines, the skill becomes almost a necessity to him; and he must acquire it sooner or later, if his hand camera work has not already initiated him into the mysteries of the art.

The specialist in higher lines already knows the full value of the process in his work, and may not be in any way helped by anything the writer may be able to say on the subject; and we there-

fore address our remarks to him to whom the work, though not necessarily unknown, has not yet its full significance.

The botanist who finds in his cross-country rambles a field of mullein and fails to turn onto it his camera fails also to pick up for his pupils a very instructive lesson on the "struggle for existence," and the "survival of the fittest." The "Streamlet's bank in woodlands dank" may furnish him abundant material for evidence of adaptation to environment, as may also "Yon low tam-rack's needled swamp" from which this "Streamlet's amber waters flow." A photograph of the spreading beach tree dropping its canopy of shade over the beautiful, graceful clumps of *Monotropa*, placed before the pupil, will awaken an interest that the wood-cut in the text, however well executed, can never arouse. A picture of the pollen clouds from a clump of nettle will arouse the curiosity of the student to know the mechanism by which such a striking phenomenon is produced.

But summer is not the only time when the teacher of botany may use his camera. When the leaves have dropped let him photograph a few trees against a clear sky, choosing an elm and a cottonwood; and then let him compare results with the cuts in even that gem among texts on elementary botany, Bergen.

But granting that our cuts are perfectly satisfactory or that we have very easy access to all the trees whose method of branching we wish the student to discuss, have we sections of all the forms our text describes? We certainly wish the student to gain his information firsthand wherever possible, and hence we have in many cases to substitute for the form the text describes, another which shows the same structures, differently disposed, it may be. Where is our cut? With our low-power objective we can photograph almost every slide the student of elementary botany should have put into his hands. We make our own cut. We would not urge that the photograph may take the place of the diagrammatic or semi-diagrammatic drawing that the student shall make, but only that it shall complement it. It appears to us self-evident that close questioning from an accurate representation of what the student sees and studies will be more effective than will the quiz on his own drawing. Ofttimes the photograph will enable him to interpret his section with much less study and effort than he must expend on the section alone to arrive at the same result. For example, we give to a student for study sections of the rhizome of *Pteris* sp. From his text, he determines, either before or after his

drawing is made, that certain structures he sees are scalariform vessels; but what to make of those bridging lines extending from one wall towards or even to the opposite, is more than he can tell. Now as the photograph represents more accurately than can the student with his pencil, if he be given side by side the photographs of the cross section and the longitudinal, he will interpret much more quickly from the former than from the latter. Has he lost discipline by taking the short cut to final results? Or to put it differently, has he gained less by the short cut?

We need not multiply specific cases; every active, earnest teacher can call to mind instantly very many cases in which a good photograph of a given section in his possession would have been of considerable assistance to himself and not a little benefit to his students.

There is nothing, absolutely nothing, that will take the place of the diagrammatic figure builded by the teacher before the eyes of the student in lecture or class explanation; but when this work has once been done how much more valuable is the photograph, the stereoptical image projected upon the screen, if the apparatus be at hand, or, in default thereof, the bromide enlargement at least.

"No apparatus" need not be cried as reason for not attempting some of this work. A good low-power objective, thirty-five cents for a dozen dry plates, half that amount for developer and fixing bath, an extemporized dark room, some soup plates or some well made wooden trays paraffined on the inside, a wooden five-pound starch box, a few ounces each of perseverance and ingenuity, are all that are absolutely essential for making a beginning. The writer has yet some very creditable work that was produced without the use of more or better apparatus than is mentioned above.

Most schools able to employ a teacher of botany and a teacher of zoology or, in place of the two, a teacher of general biology, are able to have a well made photographic outfit, and such should have it.

One caution only it seems necessary to add. The use of high powers in micro-photography without the properly adjustable apparatus, rigidly made, and without objectives properly corrected for the work, will result in complete and discouraging defeat.

In another issue of the Journal, when time has allowed the making of necessary cuts, some definite directions how to do and what to use may be given for such as need the help.

Hillsdale College, Dec. 15, 1897.

Some Methods of Determining the Positive or Negative Character of Mineral Plates in Converging Polarized Light with the Petrographical Microscope.

DR. M. E. WADSWORTH.

In giving instruction in the use of the petrographical microscope as a polariscope, I have found a few directions of value to my students—directions which I do not remember of having ever seen published. Since by varying the powers, the petrographical microscope can be used with mineral plates of any standard thickness, the directions here given can be used with the ordinary polariscope plates, as well as those thinner ones prepared expressly for use with the microscope.

I. UNIAxIAL MINERALS.

When the mineral plate shows the common uniaxial cross in converging light, its positive or negative character can be ascertained by means of the gypsum plate or quartz wedge, as well as by the ordinary mica plate.

(1) Use of the Gypsum Plate.—Examine the mineral plate, which, in converging polarized light between crossed nicols, shows a dark cross or part of a cross with or without colored rings or arcs. Insert the gypsum plate in the slot in the body of the microscope, above the objective. The cross is then resolved into colored hyperbolas. The central portion is red, terminated on the ends with yellow, and bordered on the side by blue. If the blue that borders the red lies on a line parallel to the axis of least elasticity, the mineral is positive; but if it lies on opposite sides of this line, the mineral is negative. The gypsum plate is often more satisfactory in its use than the mica plate for these determinations.

(2) Use of the Quartz Wedge.—Insert the quartz wedge thin end forward. When the wedge is gradually pushed in, the cross resolves itself into colored arcs that cross the field of view from two opposite sides of the field, and pass out of sight on the other two sides. These arcs follow each other in succession as the wedge is pushed in. If these colored arcs advance towards the center of a line parallel to the axis of least elasticity, the mineral is positive; but if they march toward the center from opposite sides of that line, the mineral is negative.

The use of the quartz wedge is less liable to error than either of the preceding, and beside it can be used in many cases where the others give no results.

(a) If the uniaxial plate is cut so that it shows arcs of rings, its positive or negative character can be determined by placing the arcs so a line perpendicular

to them shall make an angle of forty-five degrees with the cross-hairs. By use of the quartz wedge, colored arcs or rings can often be brought into the field, when otherwise none are seen. Push in the quartz wedge with its axis of least elasticity tangent to the arcs. If the rings then move outwards with their convex side forward, and, in time, a black or partially black arc appears, the mineral is positive; but if the arcs move with their concave sides forwards, the mineral is negative.

As a check against any error, turn the wedge over and push it in, so its axis of least elasticity will be perpendicular to the arcs. If then the arcs move with the concave side forward, the mineral is positive; but if they move with the convex side forwards, and a black or partially black ring or rings show, the mineral is negative.

(b) A uniaxial plate cut parallel to the vertical axis can have its positive or negative character shown in converging polarized light as follows: Place the plate at an angle of forty-five degrees with the cross-hairs so as to show the colored arcs or imperfect hyperbolas. Push in the quartz first with its axis of least elasticity perpendicular to the vertical or optic axis of the plate. If on pushing along the quartz wedge a dark hyperbola is seen to pass over the field, the mineral is positive. Again, push in the quartz wedge with its axis of least elasticity parallel to the vertical axis of the plate. If then a dark hyperbola is seen to traverse the field, the mineral is negative.

II. BIAxIAL MINERALS.

In order to render intelligible the directions later given, there is here stated the method published in the text-books for determining the positive or negative character of a biaxial mineral plate.

If a line of extinction of a biaxial plate properly cut is placed parallel to one of the cross-hairs, it shows a cross with unequal arms; but if the line of extinction makes an angle of forty-five degrees with that cross-hair, it shows two dark hyperbolas, whose vertices or eyes mark the position of the vertical axes. Accompanying the cross and hyperbolas are colored lemniscate figures. Oftentimes the hyperbolas are wanting and only the colored lemniscata can be seen; but by the insertion of the quartz wedge, the hyperbolas can frequently be brought into the field.

(a) The positive or negative character of this biaxial plate can then be determined by placing the plate on the stage in such a position that a line joining the hyperbola eyes, or bisecting the lemniscata through their longest direction, shall form an angle of forty-five degrees with

the cross-hairs. Push in the quartz wedge with its axis of least elasticity parallel to the line joining the hyperbola eyes. If the hyperbola eyes open and move toward the center of the lemniscate figure, the mineral is positive.

Push in the quartz wedge with its axis of least elasticity perpendicular to the line joining the hyperbola eyes. If these eyes open and move toward the center of the lemniscate figure, the mineral is negative.

Of course, if in either case the eyes contract and move outwards, this is proof, when the axis of least elasticity of the quartz wedge is perpendicular to the line joining the hyperbola, that the mineral plate is positive; but if they move outward when the axis of elasticity is parallel to the chosen line, the mineral plate is negative.

This method is less satisfactory in practice than the one where the eyes open and move inwards.

(b) The above method given in our text books can be supplemented by one that can be employed in numerous cases when both of the hyperbola eyes can not be seen, but only one of them or only the lemniscate arcs. In either of these cases the positive or negative character of the mineral plate can be ascertained; if one can determine the position of the line joining the hyperbola eyes or optic axes, by the form of the interference figures, by the position of the larger arm of the cross, or by any other means. When this direction is observed, place the arcs so that the direction of the line joining the hyperbola vertices shall be perpendicular to, or bisect, them; also have this line make an angle of forty-five degrees with the cross-hairs, as before. Push in the wedge with its axis of least elasticity perpendicular to the arcs, or parallel to the line joining the hyperbola eyes. If the lemniscate arcs move in towards the center of the field with their convex side forwards, the mineral is positive.

Push in the wedge with its axis of least elasticity tangent to the arcs, or perpendicular to the line joining the vertices. If the arcs then move in with their convex side forwards, the mineral is negative. If the arcs move outwards with their concave side forwards, the mineral in the first position of the wedge is negative, and in the second position positive.

(c) If the distance between the hyperbola eyes is not so great but that they lie within the field of view, the mica and gypsum plates can both be employed to determine the positive and negative characters when the lemniscate figure is placed as before, with the line joining the hyperbola eyes forming an angle of forty-five degrees with the cross-hairs of the eye-piece. Insert either the mica

plate with its axis of least elasticity parallel to the chosen line, or else insert the gypsum plate with its axis of least elasticity perpendicular to the chosen line. With either plate in this position, the arcs on one side of the hyperbola eyes will enlarge and those on the other side contract. If the arcs that lie on the inside of the eyes, or nearest the center of the figure, enlarge, and those on the outside contract, the mineral is positive. On the other hand, if the arcs nearest the center contract and the outside arcs expand, the mineral is negative. This method can be used with plates that have too great an axial divergence for their determination when the unsymmetrical cross is placed with its arms parallel to the cross-hairs.

III. THE CHROMATIC SCALE.

Many students find it difficult to follow the color-scales given in most text-books of petrography owing to the numerous subdivisions of the scales. This difficulty can be obviated in part by each student making for himself a color-scale suited to his eyes and experience. It is found that many students mistake their ignorance of the names of color-tints for color-blindness. The scale is made by placing the quartz wedge on the stage of the microscope with the nicols crossed. Then push the wedge with its thin end forward through the field of view of the microscope. Note the colors as they rise in the scale, as the successively thicker portions of the wedge pass in view. The scale thus noted will be suited to the wedge employed and to the student using it at that stage of his experience. The operation can be repeated with the nicols parallel if desired.

IV. SECTION AND PLATE.

I have found it convenient in practice to distinguish the terms "section" and "plate" in the microscopic study of minerals and rocks as follows: The term "section" is employed to indicate the entire mass of the rock or mineral that is carried by the glass slide used on the stage of the microscope. The term "plate" is introduced to designate a particular section or slice of mineral or other substance that forms a part of the rock or general mass carried by the glass slide. A "section" is composed of "plates." A rock "section" is usually made up of many mineral "plates," either held together by intercrystallization or by some cementing material, which material in its turn lies in an irregular "plate" or in "plates."

"Plate" is never the equivalent of "section," unless a single "plate" of one mineral forms the entire "section."

Michigan College of Mines, Houghton, Michigan, December 16, 1897.

REPRESENTATIVE AMERICAN LABORATORIES.

I. Cornell University.

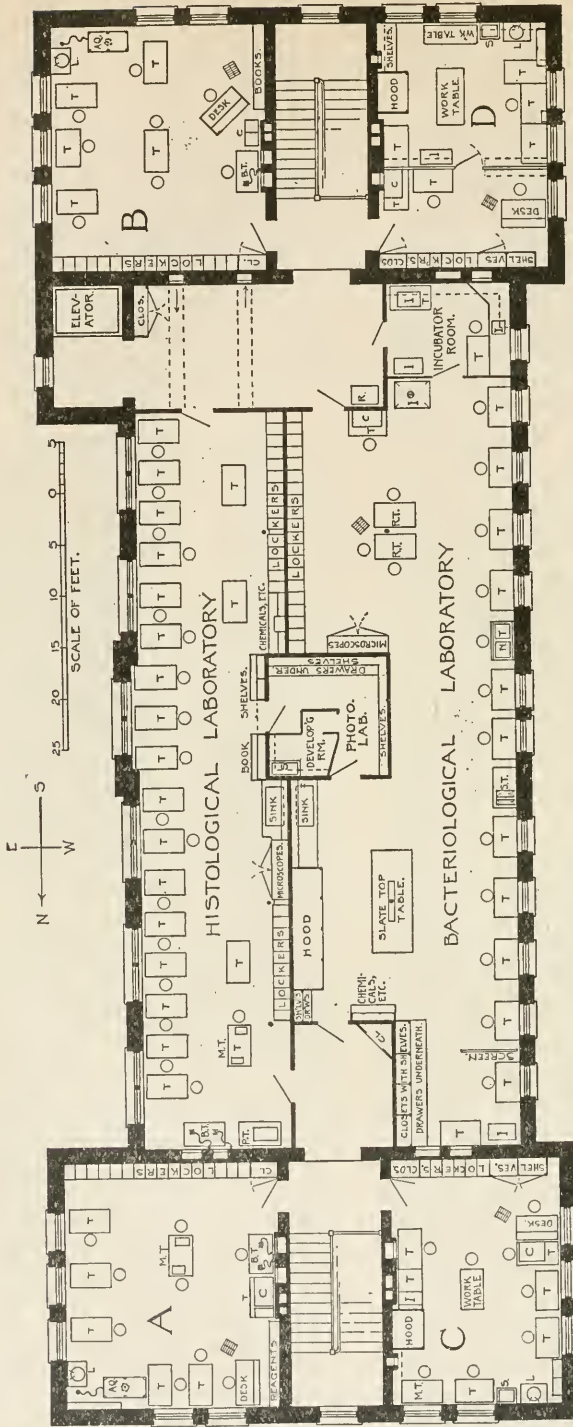

PLAN OF THE LABORATORIES OF MICROSCOPY, HISTOLOGY, AND EMBRYOLOGY, AND OF BACTERIOLOGY AND PATHOLOGY.

- A.—Laboratory for Research in Histology and Embryology.
 - B.—Laboratory for the Professor in charge of Microscopy, Histology, and Embryology.
 - C.—Laboratory for Research in Bacteriology and Comparative Pathology.
 - D.—Laboratory of the Professor in charge of Bacteriology and Comparative Pathology.
- A₁—Aquaria on movable tables. Supply and waste tubes are rubber hose.
 B₁—T₁—Tables with Runson burners, etc., in the laboratories of histology.
 C₁—Cabinets for microscopical preparations in all rooms.
 D₁—Chests for clothing, etc.
- I.—Incubator.
 L.—Wash basins in all cornerrooms.
 M.—Microscope tables.
 N.—Table for large neutralizing vessel. It is covered with a glass hood.
 P.—Table for paraffin oven (Little's form) in the histological laboratory.
 R.—Refrigerator.
 S₁—Sinks.
 S₂—Slate-top table with apparatus rack.
 T.—Tables in all rooms.



MAIN BUILDING OF THE NEW YORK STATE VETERINARY COLLEGE.

UPPER FLOOR DESIGNED EXPRESSLY FOR THE LABORATORIES OF MICROSCOPY, HISTOLOGY, AND EMBRYOLOGY, AND OF BACTERIOLOGY AND PATHOLOGY.

Representative American Laboratories.

This series of articles does not pretend to deal with the institutions to be described in their entirety, either as to equipment or methods of working employed in them. The limitations of space will render it possible to give only the briefest description of those laboratories in which microscopic work is done, and then to present a slightly more detailed account of the most complete. The purpose is to give such information as will aid in the more systematic arrangement and conduct of existing laboratories, and perhaps furnish useful hints for those planning the construction of new ones, as well as to stimulate a general desire for better laboratories everywhere.

I. Cornell University.

All the laboratories are abundantly supplied with compound microscopes, and also with dissecting microscopes, according to their needs, and with specimens for illustrating the various courses, and for research work, whether the forms required are native or have to be procured from a distance. The recent development of reliable depots for laboratory supplies renders it convenient and inexpensive to place before classes the most desirable material in sufficient quantity for dissection and microscopical study. The laboratories are all pro-

vided with their type collections of prepared slides, some for class use as guides to what a typical preparation should be, others for the demonstration of subjects too difficult for class preparation or which would not be likely to be met with in the course of the work. Small libraries are attached to all the laboratories and contain only such books as are required for actual use during the laboratory exercises, it being the policy of the university to concentrate the library in such a manner that it will be equally accessible to all. The general library is

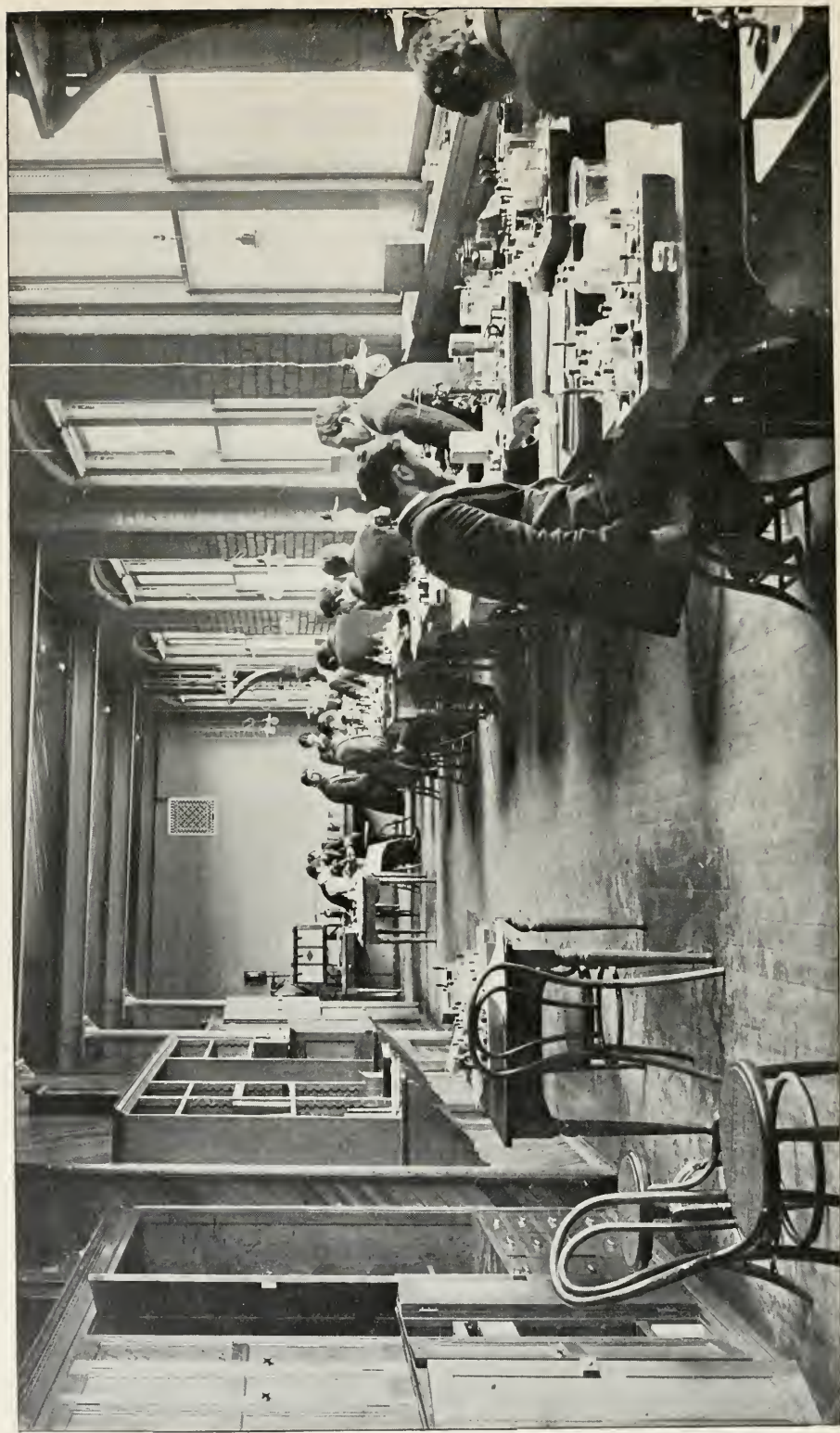

GENERAL LABORATORY FOR MICROSCOPY, HISTOLOGY, AND EMBRYOLOGY.

therefore the Mecca of all the special as well as the general students, and no more congenial place for study could be devised than its excellently arranged reading rooms. The special libraries are very complete for each of the groups of sciences, and great attention has been paid to current periodical literature as the basis for advanced work.

Botanical Laboratories.

The laboratories for vegetable histology, phanerogamic botany, comparative morphology, and embryology, mycology, algology, and kindred subjects are still contained in buildings not especially constructed for laboratory purposes. The arrangement of the work-tables, reference material, and apparatus does not differ materially from that in any modern laboratory.

The comparative histology of plants and systematic botany share the same rooms, there being a general and a research laboratory. Adjacent to the work-tables in the general laboratory, the university collection of phanerogams is arranged in cases extending from ceiling to floor. The abundance of the material in the herbarium, its systematic and convenient arrangement, and its accessibility from the work-tables, where the student may employ the dissecting microscope and hand magnifier to advantage in the work of identification and study, and especially the complete local flora, are particularly advantageous features. The students in histology who work in this room are each provided with a compound microscope, having a low and medium-power objective and two eyepieces. If required, this equipment can be supplemented by the addition of an oil-immersion lens, of which the laboratory has a supply. Fresh material and material in the proper state of physiological activity is obtained from the large, well-kept greenhouses adjacent to the laboratories. The research laboratories are fully equipped with microscopical apparatus, each student having a separate table with wall-case for reagents and material. The classes are divided into small sections, so that no matter how many apply for work, each section receives the personal care and instruction of the professor and assistants in charge, an advantage to the student which can only be supplemented, never replaced, by any refinement of methods in class-work.

The general laboratory for comparative embryology, mycology, etc., is arranged much as the histological laboratory described above. In addition to the collection of fungi, etc., there is a magnificent set of models of typical fungi and other groups of plants, an abund-

ance of charts illustrating plant structure, generic characters, etc., and a large collection of photographs of the forms which have from time to time come under observation. There is also a complete equipment for bacteriological cultures and for the propagation of moulds. The constant use of photography for recording the appearance of specimens studied, even the Roentgen rays being occasionally employed, is an especially noteworthy feature of this laboratory. The research laboratory in connection with this department is supplied with a very complete microscope and microtome equipment and is so arranged that it may be entirely isolated from the general laboratories during the progress of work if desired.

Laboratories of Microscopy, Histology, and Embryology, and of Bacteriology and Pathology.

The laboratories of Microscopy, Animal Histology and Embryology, and of Bacteriology and Comparative Pathology are newly constructed and may be taken as types of properly arranged and equipped modern laboratories. They are located on the upper floor of the new Veterinary College building. This structure is of yellow pressed brick with door and window facings of Indiana limestone, trimmings of terra cotta, and base of Gouverneur marble. The dimensions are 142 x 42 feet. The choice of the upper floor of a building for a laboratory has the advantage of securing purer air, less dust, less noise, and better light.

By referring to the ground plan of the laboratories it will be seen that the space is divided longitudinally, the general laboratories occupying the central portion of each side, with the research laboratories at one end and the professors' rooms at the other, of the building. The lighting of the floor is, taken as a whole, perfect, the building standing north and south and the windows being very large and arranged the proper distance apart for the accommodation of the work-tables. Everything, from the original plan of the building down to the minutest details of carrying out individual work, is arranged to secure the greatest physical comfort for the students and the most rapid, accurate, and economical methods of work. The long and comparatively narrow room permits every part of it to be properly lighted and brings the wall-cases within convenient reach of the work-tables, which are arranged opposite the windows so that the student, when using the microscope, may sit facing the light, the proper position for work. The ceilings are very high and the air is kept

always fresh by means of ventilating fans. The automatic thermoregulators maintain a constant temperature of 70 degrees. No superfluous wood is permitted anywhere, and a complete system of water-pipes and hose stations extends throughout the entire building.*

Laboratories of Microscopy, Histology, and Embryology.—The general laboratory is designed for eighteen students at one time, as a larger number cannot be given the desired personal attention. Each student is provided with a compound microscope having coarse and fine adjustment and fitted with two eyepieces, and with a low and medium-power dry, and with a one-twelfth inch oil-immersion objective, triple revolving nose-piece, Abbe condenser, and iris diaphragm. This equipment is considered the least which should be provided for microscopical work. Each student also has a whole table to himself and is furnished with a locker convenient to his table, wherein he may keep all his accessory apparatus and supplies.



LABORATORY TABLE

The work-table is of quartered oak 125 x 72 centimeters on top and seventy-two centimeters high. This height has been found the most convenient and least liable to cause an unnatural position of the body. The dimensions of the top are as great as can be utilized conveniently and the space is also sufficient for all the apparatus needed at one time.

* The excellence and adaptability of the Veterinary College building are in large part due to the cordial sympathy of the architects (Professors C. F. Osborne and C. A. Martin) with the work and needs of modern laboratories, and their readiness to consider the suggestions of those who were to use the building and its furniture.

The seats are four-legged piano stools with cane tops, thus being adjustable for height and convenient for any desired position. Two pieces of apparatus are always to be found on the tables, a small glass waste-jar, over the top of which (see figure) there is a pair of connected metal rods supporting a small metal funnel. In preparing slides they may be laid on the rods and irrigated, or staining material placed on the object. When it is desired to drain off superfluous stain or to wash the preparation, the slide is stood on end in the funnel until drained. The other article is the eye-shade, consisting of a metal base formed of a small tin dish filled with lead, into which a wire bent at right angles at the top is inserted. Upon the bend of the wire is hung a sheet of common manilla paper of such a length that it shall be just above the stage of the microscope. As the student sits facing the light the eye-shade is placed in front of the microscope and excludes the light both from his eyes and from the upper surface of the object.

The lockers, like all of the woodwork in the laboratory, are of quartered oak. Each is provided with a combination lock, the combination of which is known to the student to whom it is assigned and the laboratory director, only. The lockers themselves contain no fixtures whatever, being provided with six pairs of slides. The laboratory owns a large number of reagent boards and drawers, all of which are exactly the same size and of the proper width to fit into the lockers. Each student is provided with as many of these reagent boards or drawers as his work requires, and all reagent bottles, glassware, accessory apparatus, material, etc., are always to be kept on the boards or in the drawers. It will thus be seen that as all boards and drawers are perfectly interchangeable, there can never be any confusion resulting from changing the boards from one locker to the other, as is certain to occur sooner or later, and no care need be exercised to prevent such interchanging. The reagent boards are of light pine one and seven-eighth inches thick and have on one side depressions in which the bottles or dishes containing reagents, specimens, etc., are set. When a tray only is desired the reagent board is simply reversed and the bottom used for the purpose. The exact construction of the lockers and reagent boards and drawers is shown in the accompanying figures, which are drawn to scale.

Each microscope owned by the laboratory has a separate locker with combination lock. The microscope lockers are all contained in a large cabinet (See Fig.), which in turn has heavy doors

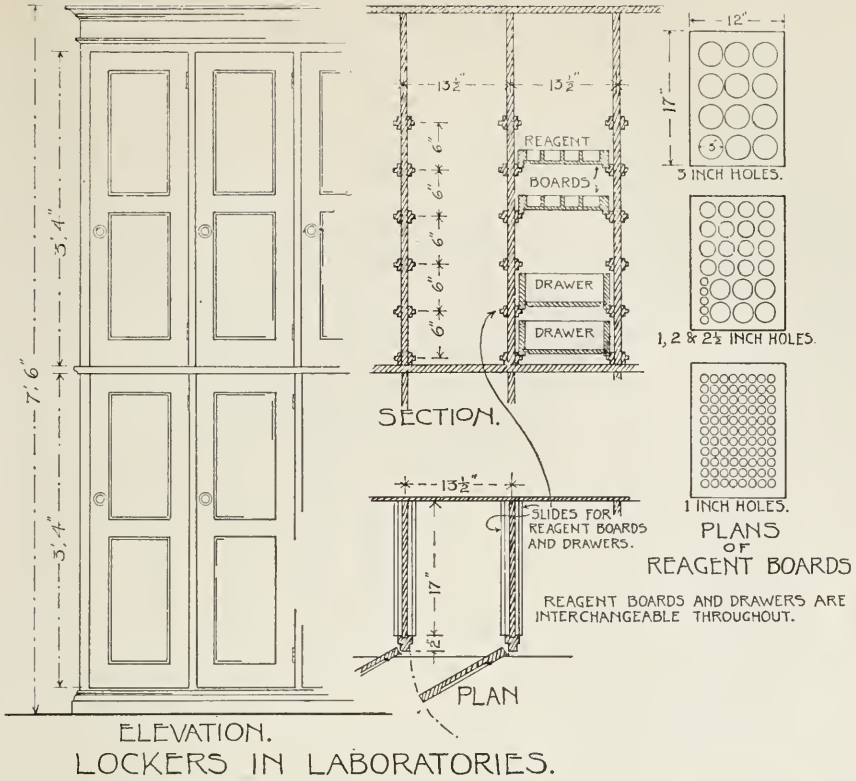

with safety locks. One or two students, as the case may be, are assigned to use one microscope, and to them only is given the combination of the lock securing the instrument. In this way the responsibility for breakage or careless usage is definitely limited to one or at most two students. The director of the laboratory has further control of the microscopes, in that when the working hours have elapsed the doors of the cabinet may be closed and no one may remove an instrument without proper authority. This system is a valuable one, not only as preserving the microscopes properly, but in impressing the student with the fact that he is using delicate and valuable apparatus which must be properly cared for in order to yield good results.

In order to keep the laboratory equipment intact and to still further impress the responsibility of the work upon the students, all apparatus used is charged against the user, and loss and breakage is deducted from a deposit made at the beginning of the work. The system is used in all the biological laboratories.

The sink, shelves of reference books, and chemicals are centrally placed so

as to be equally accessible from all parts of the room. The chemical shelves are arranged on either side of a niche containing a small balance, so that the student may select and measure out at once the exact amount of material required, and that it shall be done at that one place only. At the lower end of the room (at P. T.) a special table supports a large paraffin bath, containing twenty-four separate drawers, one for each student. This bath is kept running at a constant temperature, the students not being required to attend to it. One table (B. T.) is provided with Bunsen burners and supports for heating dishes, also the paraffin cans. All processes which require heat are done here only. The microtomes are placed on a separate table (M. T.) and all sectioning must be done here. It is found convenient to have three unoccupied tables in the space between lockers and tables, upon which a tray, book, microscope, or other object may be placed, as while opening a locker or for a short time only.

There is a complete photographic laboratory which may be used from either of the general laboratories on the floor and which contains all the necessary appa-

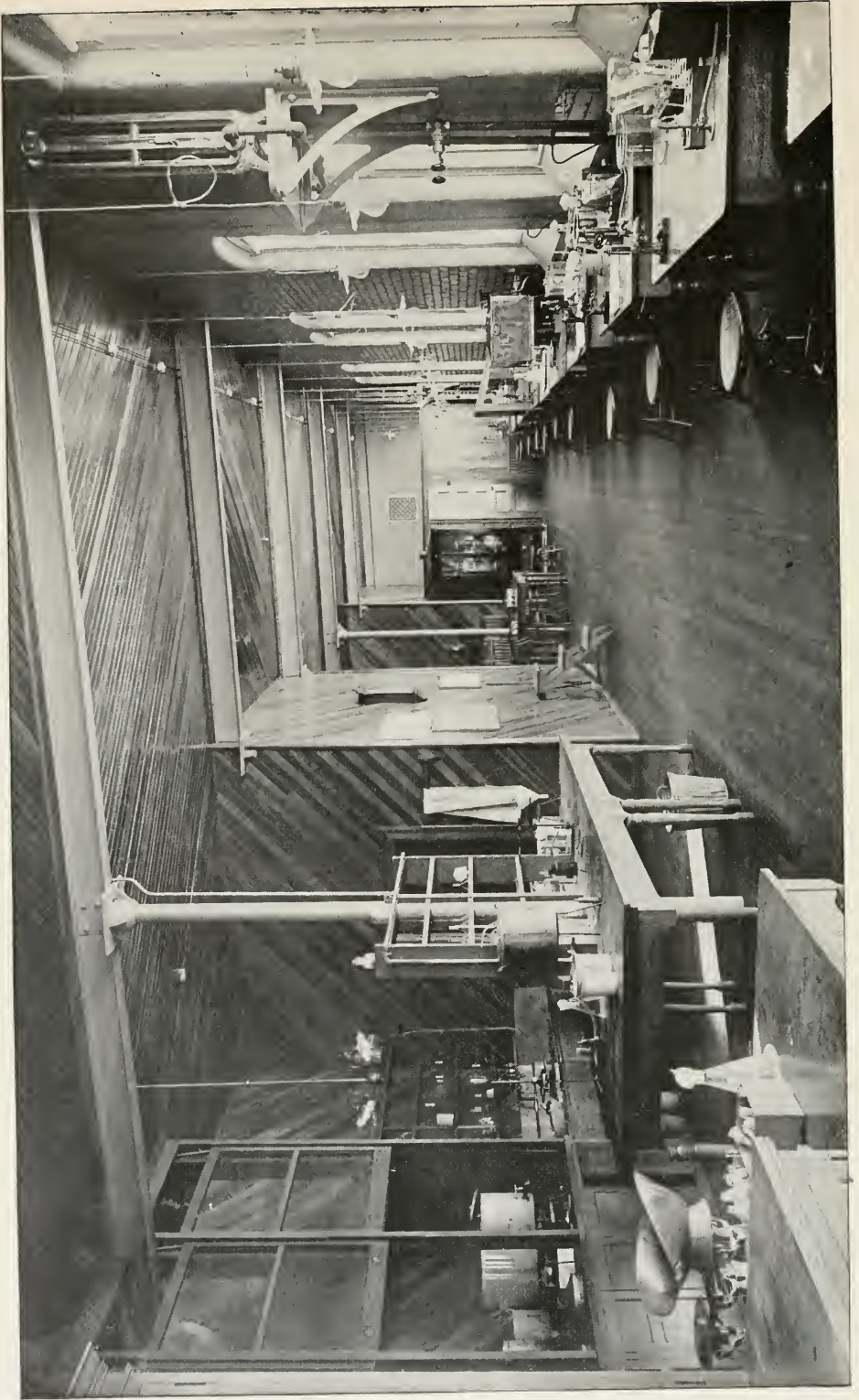

GENERAL LABORATORY FOR BACTERIOLOGY AND PATHOLOGY.

ratus and chemicals for developing, printing, and finishing the prints. The simplicity and practical nature of this whole arrangement is best seen when the laboratory is in use. When the students enter, the room is entirely clear, not a bottle or dish in sight except the small glass waste jar and eye-shade on each table. It is, however, but the work of a moment for each to open his locker, secure microscope, reagents, and material, all of which are placed on the work table (T), and commence work. At the end of the period a scarcely longer time is required to replace the apparatus on the reagent boards and

laboratory work, and forms the basis for all the other courses in which the microscope is used.† The equipment for this work consists of a good working set of accessory apparatus, including camera lucidas, polariscopes, micro-spectroscopes, filar micrometers, ocular micrometers, cover-glass gauges, apertometers, a complete micro-photographic outfit; a complete photographic outfit for macroscopic work and a collection of microscope slides especially prepared as test objects to determine not only the quality of the objectives and other optical apparatus, but to prove the validity of the images seen. There are

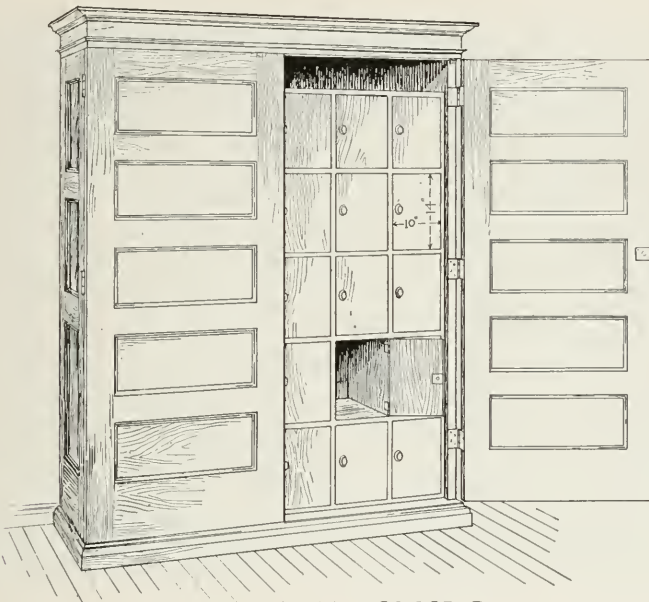

CABINET FOR MICROSCOPES.

put them in the lockers again, leaving the laboratory as clear as before, no misplaced articles, no apparatus exposed to dust and danger of breakage, and above all the habit of "method" instilled into even these well-grown pupils.

This is one of the few laboratories in the country where it is deemed necessary to teach the student the proper use of his tools before he is given journeyman's work to do, and one of the still fewer number in which will be found an accessory equipment adequate or planned for the purpose of demonstrating the points which the student will be required to know in order to do intelligent work with the microscope. The course in the practical use of the microscope extends over five weeks, consists of lectures and

enough of each kind of object so that each student may have one.‡ The idea is to have the student actually do all

†The basis of this course is Professor S. H. Gage's book, "The Microscope and Microscopical Methods," the subject matter of which treats of the microscope and its parts, lighting, focusing, manipulation of objectives and care of the microscope and the eyes, interpretation of the appearance of objects under the microscope, micrometry, drawing with the microscope, micro-spectroscope and polariscope, slides and cover glasses, mounting, sectioning, isolation, preparation of reagents, micro-chemistry, etc., etc.

‡To give an idea of the scope of this work I noted the objects in the first few drawers of the test-slide cabinet: fly's wing, striated muscle, blood of necturus, letters and figures printed in black on thin paper and mounted in balsam, *Pleurosigma angulatum*, *Bacillus coli*, etc., etc.

of the operations necessary for practical work and to give him such information that he will be able to strike out independently and intelligently in any direction in which his investigation may subsequently lead him. Before passing on, it may be well to note that the successful and economical conduct of the finances of these laboratories depends on the adoption and rigid adherence to a simple and adequate system of controlling the quality and quantity of purchases and the amount of expenditures. When the original equipment was purchased every item was entered upon suitable cards, which

erty. Any defects in supplies purchased or unsatisfactory transactions can be noted for future reference when placing orders. The card system has the advantage over others that obsolete matter can be easily discarded.

The research laboratory (A) is provided with the same kind of tables, stools, and lockers as the general laboratory, also special table for Bunsen burners, etc. The microtome is one of the most used instruments here and the table in the middle of the room is provided with two of the most complete instruments obtainable, one for serial work, the other for collodion sectioning



HOOD FOR STERILIZERS, SLATE-TOPPED WORKING TABLE, AND GENERAL REAGENT CASE, IN BACTERIOLOGICAL AND PATHOLOGICAL LABORATORY.

were afterward filed alphabetically under the name of the article in a card cabinet (see plan). The entry not only included the name of the article, but the name and address of the manufacturer or dealer of whom obtained, and the catalogue number by which it is known, together with the date of the catalogue referred to, dimensions, and number or quantity ordered, date of order, and date order was filled. When subsequent purchases are to be made the cards are consulted and are an accurate guide to the amount of material which will be required for a stated period as well as giving the source of supply and the cost. From these records the expenses of the laboratory can be reckoned for any given time as well as an inventory of its prop-

erty and cutting large pieces of tissue and large objects. The assistant professor's roll-top desk and revolving book-case occupy a quiet corner. A large aquarium with a constant supply of running water furnishes living material. The card cabinet and cabinet of prepared microscopic objects is also found here, the latter containing the especial series illustrating the more difficult problems considered. The professor's private room (B) is equal in size to the research laboratory and serves the purpose of study, office, and private laboratory. Here special demonstrations of difficult subjects are given to small groups of students, who are thus brought more closely in touch with their preceptor. The lockers, work-tables, aquarium,

burner table, card and object cabinet are the same as described. One table is, however, provided with a plate glass top, one-half of which is underlaid with black and the other with white paper for dissection work. A high and low-power Brücke type lens and a variety of lens-holders complete the equipment. The professor's large roll-top desk and revolving book-case are placed conveniently to the book-shelves containing his books, pamphlets, and reports. The lockers contain the unmounted microscopical material for class use together with all the other material involved in personal investigation. Here again the card cabinet intervenes to bring order out of what would otherwise soon become, if indeed it could ever be otherwise than, chaos. The material is of course mostly in bottles, and these are kept in any of the forms of reagent boards shown in figure 2. Each locker is numbered and each board in the locker also. The transverse rows of holes in the boards are also numbered, beginning in front. It is thus possible to designate on the cards in the card cabinet the exact location of any object. The rule is then simply to record on its particular card the location of every addition to the collection and to adhere to the practice of always putting the material back in its place. The simplicity and accuracy of the system may be best illustrated by an example. Suppose one is to find among the several hundred bottles of specimens one containing isolated ciliated epithelium from the horse. It is only necessary to refer by the guide cards to "Epithelium," then under "C" ciliated epithelium, and the record appears, with a reference for example, "16, 4, 8|3," meaning that the desired bottle is in locker 16, tray 4, the eighth row of holes and the third hole in the row. Compare such a system with the quite common one of literally "pawing" through a mass of unclassified or partly classified "debris" until the desired article, perchance, comes to light! To return the bottle to its proper place it is only necessary to consult the record on the label. As the collection grows it classifies itself, new specimens being recorded on cards already containing the record of similar material or adjacent to it, and being assigned adjacent positions in the trays.

The card cabinet is also used for bibliographical purposes and for recording the results of observations and all kinds of information.

The Bacteriological and Pathological Laboratories.—These occupy the west half of the upper floor and are the same in general arrangement and equipment as the laboratories just described, the

tables, stools, lockers and reagent boards being the same, with the exception of a special board which is arranged with wooden pegs as shown in the figure, so that test tubes, bottles, etc., can be placed upon it to dry and kept inverted, preventing dust from falling into them.

The windows in the general laboratory are, however, arranged at equal distances from each other and there are tables for ten students only, as a greater number could not conveniently work at one time and do all their own work at the sterilizers, etc. The special features of the general bacteriological laboratory are the incubator room with its three

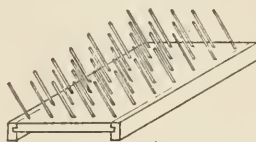

RACK FOR DRYING BOTTLES.

large incubators for pathogenic and special cultures. (All connections between the incubators, sterilizers, and burners, and the gas supply are made by means of small lead pipes. This pipe offers the advantage over rubber hose that it does not rot out and does not permit the escape of gas into the air. In case of a burner lighting back, the lead pipe will not burn as rubber would. The connection between the lead pipe and the gas pipe or burner is made by means of rubber tubing, and where burners are to be moved about the rubber tube can be a foot or so long.) The student's everyday cultures are kept at the proper temperature in a gigantic incubator which stands in the work room (I, at the left end of lab. in plan). Each section has its own shelf in the incubator and each student's cultures, be they few or many, are kept in an easily sterilizable tin receptacle specially provided for that purpose. Each work-table has a Bunsen burner with by-pass so that the flame may be shut off with the exception of a small side-flame, which ignites the main flame by simply turning the valve open. There are several large hot-air sterilizers all grouped under the hood (see plan). The steam sterilizers (ST) are of special construction and of ample size for the accommodation of the sterilizing receptacles of an entire section.

The nivellating table (NT) is designed to take the place of the usual forms of nivellating apparatus, as it is itself perfectly level, is provided with several shelves divided into compartments, the whole being covered with a glass hood, excluding dust but not light. The area

in the middle of the room is occupied at one end by a large slate-topped table with a large water-bath, and at the other by a revolving book-case holding the standard reference works, two reading tables, and chairs. The work in this laboratory is of the most practical character. Each day's work is definitely outlined, and reference sheets giving explicit directions for every operation which the student is expected to perform are supplied. The general course of the work is outlined in a general lecture covering several days of laboratory work. The student is taught from the first the importance of a thorough knowledge of the apparatus which he is to use and the importance of the scientific care and cleansing of it. The microscopic equipment is the same as in the microscopic and histological laboratories, and the most of the students have had their preliminary training in the use of the microscope there. The research laboratory (C) has a roll-top desk and revolving bookcase for the assistant professor, lockers, tables, stools, microtome table, sink, etc., as in the laboratory "A" described. There is in addition a full set of incubating and sterilizing apparatus, including a large autoclav. The professor's room (D) is divided by a partition into an office room with desk, bookcases, card and specimen cabinets, and tables, and a private laboratory fitted up with all the apparatus necessary for the culture and study of bacteria and allied forms. The arrangement and fixtures are well indicated in the plan.

In conclusion it may be said that the utmost cleanliness and order is maintained in every detail and the physical comfort and health of the students is as carefully looked after as is the culture of germs.

While this article deals especially with the laboratories of plant and animal histology, bacteriology, and pathology, it should be said that excellent laboratory facilities are also offered in entomology and invertebrate zoölogy, in vertebrate zoölogy, in mineralogy and petrography, in physics, and in chemistry. Naturally, however, the work in those departments, except perhaps entomology, is not so largely microscopic.

L. B. ELLIOTT.

Rochester, N. Y., Jan. 15, 1898.

Note.—The writer wishes to acknowledge his indebtedness to Prof. Gage, Dr. Moore, Professor Rowlee, and Messrs. Weigand, Reed, and Kingsbury for their uniform courtesy and aid in securing the information embodied herein.

The March number of the Journal will contain an article on mitosis, illustrated with photo-micrographs.

The Sectioning of Seeds.

It not infrequently happens that accurately made sections of some of our most common seeds could be used to advantage in classes in elementary botany.

The writer has found it very desirable to keep in the laboratory sets of sectioned seeds in sufficient quantity to supply to each member of the class a complete series.

Such a lot of sections is very easily made by ordinary methods, provided care is taken with each stage of the process.

The seeds to be sectioned, beans, corn, peas, wheat, rye, etc., are placed in a two per cent. solution of formalin and kept in a moderately warm condition for thirty-six hours or until they have become soft. (The formalin is used to prevent germination.) The seeds are then placed in a dehydrating apparatus in fifty per cent. alcohol for twenty-four hours, after which they are removed and allowed to remain in ninety-five per cent. alcohol for two to three hours. They are then transferred to a one and one-half per cent. solution of collodion (one and one-half grams of gun-cotton in one hundred cc. of a mixture of equal parts of ether and alcohol) and left for twenty-four hours. After this they are transferred to a five per cent. solution of collodion for twenty-four hours, when they may be placed on the cork.

It is usually desirable to cut a hole in the top of the cork to allow about one-third of the grain to be below the surface. The seed should be very thoroughly and carefully covered with thick collodion. After a few minutes the preparation may be placed in eighty per cent. alcohol to harden. This process will occupy four to five hours. The cork can then be placed in the microtome and the seed sectioned. Only thin sections should be taken, as the resistance in cutting thick ones will usually loosen the seed from the collodion.

A long, sweeping stroke of the knife is necessary for successful work. Should the sections show a tendency to break away in places, it is only necessary to fasten the parts by thin collodion spread over the cut surface of the seed and allowed to harden before each section is made. After the sections have been removed they may be fastened to the slide with either, stained, dehydrated cleared, and mounted in the usual way.

This method is constantly used by the students in the writer's laboratory, and the very best results secured.

Of course, the harder seeds and those whose coats will not soften by soaking must be treated by the *paraffin method.

* Rowlee, W. W.; Proc. Am. Soc. Mic. 1890; p. 113.

A Quick Method of Preparing Sections of Tissue for Class Use:

It is often desirable to prepare sections of the softer tissue in a very short time. To anyone familiar with the collodion method, the following suggestions will be helpful: Place the tissue at night in forty per cent. alcohol, in the dehydrating apparatus. Remove it at 7:30 the next morning. Leave until 10 o'clock in two per cent. collodion. Then place in five per cent. collodion until 11:45. Arrange on the cork and place in eighty per cent. alcohol. The material will be ready to section by 1:30, when it can be distributed to the class; a total of eighteen to nineteen hours covering the whole operation.

MASON B. THOMAS.

Wabash College, Jan. 3, 1898.

APPARATUS.

[Translation from Central-Blatt f. Bacteriologie. Band xxii., p. 340.]

A Simple Steam Sterilizer.

From the Hygienic Laboratory of the University of Michigan, Ann Arbor, Mich.

DR. F. G. NOVY.

In laboratories where a large number of students are working at the same time, it is often difficult to provide enough sterilizing apparatus. The apparatus shown in the accompanying figure is such that it can be procured at a very low cost. It can be assigned to either one or two students. It has been in use in this laboratory for several years and has practically supplanted the large Koch sterilizers. The lower part of the apparatus consists of an ordinary Hoffmann's iron water bath, eighteen to twenty centimeters in diameter. The upper part consists of a copper pail twenty centimeters high and twenty centimeters in diameter, with perforated bottom. Two copper rings are soldered to the interior, one being about four centimeters above the bottom and the other about twelve centimeters. These rings are about one and one-half centimeters wide, and are plentifully perforated to permit passage of steam and condensed water. The rings prevent the culture tubes from touching the sides of the pail, as otherwise the cotton plugs would become saturated with the condensed steam. The pail is filled with water-bath, in which the water should be boiling. In from five to seven minutes steam will actively issue from the tube in the cover, showing that the interior temperature has reached 100°C. With this

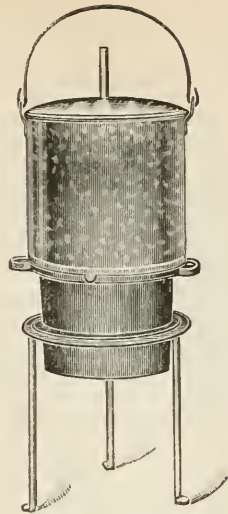

apparatus the student can attend to any needed steam sterilization at his own table, and thus save much time and obviate much unpleasant waiting. The general usefulness of the apparatus, its compactness, cheapness, and the saving in gas will commend it to those practitioners who desire to equip a small laboratory.

July 25, 1897.

A Convenient Water Bath.

The accompanying illustration shows a convenient water-bath recently made for the laboratory of the St. Lawrence State Hospital. It was designed with the view of economizing both space and

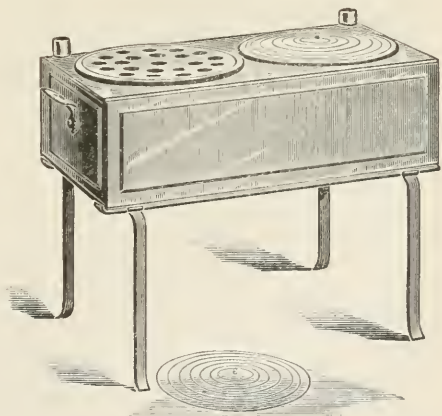

heat, both of which as a rule are important considerations in laboratories, the latter particularly in those where gas is not to be had. The bath is fifteen

inches long, seven inches wide, and five inches deep; is made of tin-lined copper, and stands upon an iron frame eight inches high. The bottom, where it is exposed to the flame, has an extra covering of sheet-iron easily removable. On the top is a place for filling, and a similar opening at the other end to hold a thermometer. There are two nests of concentric rings, five in number, giving openings of one inch to six inches, and an extra cover intended to replace the rings, which contains twenty-two openings for medium-size test tubes. The heater, which we have used in connection with this bath, is a Prinius No. 1, oil heater, which will boil the water in a few minutes. The bath has proven in operation satisfactory, and is as economical of space and fuel as could be reasonably desired.

WILLIAM MABON, M. D.

St. Lawrence State Hospital, Ogdensburg, N. Y., January 15, 1898.

ABSTRACTS.

A Simple Method for the Culture of Anaerobic Bacteria in Liquid Media.

DR. THEODORE KASPAREC, Vienna.

In order to be able to cultivate tetanus bacilli in bouillon in a simple manner, I prepared the cultures in ordinary flasks and selected the paraffin method, as recommended by Kitasato, for excluding the air. As pouring the liquid paraffin upon the inoculated bouillon did not appear practical enough, on account of the danger of foreign germs entering while pouring, the smearing of the neck of the glass with paraffin as well as the influence of the heat of the melted paraffin, I had a special flask made for the purpose, which had proved very reliable in keeping the culture air-tight.

As the manipulation is exceedingly simple, I feel impelled to recommend my method.

The flask intended for the above-mentioned purpose may be a spherical one, may be of any desired size, with a rather long neck tapering toward the top. A small tube terminating in a bulb is blown into the side of the neck of the flask about one centimeter from "C." The flask is first filled with bouillon almost to the neck and about three cubic centimeters of liquid paraffin are then added, after which the whole is sterilized in the steam sterilizer. The heat expands the bouillon, causing the paraffin to rise in the neck of the flask and overflow into the side neck and small bulb "A," so that after sterilization there is

only a very thin film of paraffin remaining on the top of the culture medium at "C."

During the heating a large portion of the air absorbed by the bouillon is driven out, and its reabsorption while the

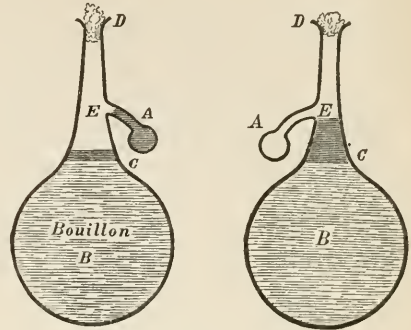

Fig. 1.

Fig. 2.

flask is cooling is prevented by the thin paraffin film. After cooling the paraffin hardens into a solid coating which can be readily pierced when it is desired to inoculate the bouillon. After inoculation the hardened paraffin in the small bulb is liquified by heating slightly, when it may be poured upon the film already formed above the bouillon by slightly inclining the flask. Upon hardening, this additional paraffin constitutes an almost perfectly air-tight layer, which becomes even more effective by being pressed into the tapering neck when the culture is heated in the incubator. This closure is made still tighter by the pressure of the gases generated in the culture.

Although the covering of anaerobic cultures with paraffin is not new and is quite simple, yet I consider this method advisable, as the flask described need only be opened once, that is, for inoculation. When pouring out the cultures after growth has taken place, the paraffin is again led into the lateral bulb after warming the vessel, by inclining the flask.

This method is likewise advantageous in the preparation of toxins, as the culture can be easily transferred in a very pure condition to the filter after the warmed portion of the neck of the flask has cooled and the paraffin has hardened in the lateral bulb.

(Central-Blatt f. Bakt. Band xx., p. 536.)

Culture of Diatoms.

Dr. Henri Van Heurck gives the following notes on the cultivation of diatoms. They may be separated by the fractional method. One drop of the

sample is diluted with one hundred cubic centimeters of the culture medium. One drop of this mixture is added to ninety-nine cubic centimeters more of a liquid medium. The last mixture is divided into ten Freudenreich culture flasks. The dilution may be carried as far as necessary until a single organism occurs in the flask.

For culture two formulæ are used as follows:

Formula "A."

Magnesium sulphate, 10 gr.
Calcium chlorate, 10 gr.
Sodium sulphate, 5 gr.
Ammonium nitrate, 1 gr.
Potassium nitrate, 2 gr.
Sodium nitrate, 2 gr.
Potassium bromide, 0.2 gr.
Potassium iodide, 6.1 gr.
Water, 100 gr.

Formula "B."

Sodium phosphate, 4 gr.
Calcium chlorate, sicc., 4 gr.
Hydrochloric acid, 20 degrees, B. 2 ccm.
Perchloride of iron, 2 ccm.
Water, 80 ccm.

The culture media to be kept separated. To one liter of water add forty drops of "A" and twenty drops of "B," five centigrams of straw, and as much moss. This should be sterilized. Water lost by evaporation can be replaced by sterilized water. According to Miquel and H. Gill, direct sunlight is injurious. *Pleurosigma angulatum*, *Cymatopleura solea*, and other species have been cultivated.

(Zeitschrift f. Angewandte Mikroskopie 3; 225). L. H. P.

Culture of Bacterial Spores.

Mayer recommends staining with potassium iodine iodide (3+3+20), and chloriodide in an hour colors the spores of *Astasia* as follows: Extine with its spines and rod in spore yellow. Alcoholic ruthium red colors extine first, later the rod. Alcoholic safranin (0.1 alcohol and water 50) colors the spores intensely when added while alive. Concentrated Delafield's haematoxylin when allowed to act for two hours, colors the membrane deep blue. Short treatment with carbolio fuchsin, and wash rapidly with hydrochloric acid alcohol (20 gr. Hcl., 100 ccm. alcohol, 200 ccm. of water) colors the spores as well as the flagella.

(Flora 84: 191-192) L. H. P.

Staining of Cytoplasm and Vacuoles.

Mayer gives the following directions: To a drop of living culture of *Astasia* add a trace of methyl blue solution (one pint concentrated alcohol methyl blue solution + 10 pints of water) the motile rods color without losing their motion. The membrane colors first, a delicate blue line surrounds the protoplast. Preparations are treated

for five minutes in vapors of formaline to fix, then stained with safranin. The structure of the cytoplasm comes out nicely. The nucleus stains nicely when treated with iodide potassium iodide solution. It is only necessary to add to a drop of the culture a little iodine on the edge of a cover slip. The nucleus of the *Astasia asterospora* usually occurs near the wall. To show vacuoles of rods, heat rather rapidly on a cover slip with a little water and then color with ruthium red. The vacuoles will mostly color red and darker than cytoplasm. (Flora 84: 206-207) L. H. P.

Asparagin Liquid Culture Medium for Bacteria.

Mayer recommends the following method of preparation: One gram each of magnesium sulphate, sodium chloride, potassium phosphate dissolved in one hundred cubic centimeters of water, heated and neutralized with sodium carbonate, heat again and filter. Increase to one hundred cubic centimeters. Take five cubic centimeters of this stock solution and add to it one gram of asparagin, two grams cane sugar ninety-two cubic centimeters of water. *Astasia asterospora* grew rather slowly in this medium at first, but later mucilage was produced rapidly.

(Flora 84 186-187) L. H. P.

Staining Haematozoa of Malaria.

Dr. E. Marchoux recommends the following formula: Saturated solution of thionin in 50% alcohol, 20 cubic centimeters; 2% carbolio acid, 100 cubic centimeters. It is necessary to let the mixture mature for a few days until the carbolio acid has combined with the thionin.—*Jour. Royal Mic. Soc.*, 1897, p. 450.

Proper Angle of Microtome Knife.

Dr. B. Rawitz adduces experimental proof to show that the microtome knife should be placed at an acute rather than at a right angle. When placed at the latter angle, the sections, according to their thickness, are always more or less crowded together, thus distorting the finer structures of the tissues cut. The experimental proof consists of the measurement of the sections cut with the knife at a right angle and also at an angle of forty-five degrees. The sections were made from a block measuring 20.5×11.5 mm., and were 15.10 and 5 mu. thick. With the knife at the acute angle they all measured 11 mm. in breadth, while with the knife at a right angle they measured 9.5 mm. for 15 mu., 9 mm. for the 10 mu., and 8 mm. for the 5 mu. sections; thus showing a shrinkage of 2. 2.5, and 3 mm. respectively.—*Jour. Royal Micros. Soc.*, 1897, p. 447.

Journal of Applied Microscopy.

Issued Monthly from the Publication Department
of the Bausch & Lomb Optical Co.,
Rochester, N. Y.

L. B. ELLIOTT, EDITOR.

Address all communications to
PUBLICATION DEPARTMENT,
BAUSCH & LOMB OPTICAL CO.,
ROCHESTER, N. Y.

ONE DOLLAR PER YEAR.
To Foreign Countries - - \$1.25 Per Year.

Entered at the Post-office, Rochester, N. Y., as second-class matter.

FEBRUARY, 1898.

EDITORIAL.

It has been suggested that a space be devoted to the asking and answering of questions, thus affording a means of communication between workers in the same or different fields who desire information which can best be obtained from the experience of others. It is thought that such a department would be the means of bringing up for discussion many subjects of general interest and of eliciting the most recent results of investigation.

We will, therefore, under the heading "Notes and Queries," print inquiries sent for that purpose. The inquiries will not be signed and all replies received will be transmitted privately to the inquirer. Such of the replies as are of sufficient interest will be printed in the "Notes and Queries" over the signature of the writer and all replies will be deemed for publication unless otherwise specified. Owing to our limited space we shall be guided by the relative importance of the subjects proposed in determining the sequence of publication. The inquiry appearing this month is a good example of a profitable kind of question to ask.

* * *

Several of our correspondents have suggested the desirability of larger type and a single column to the page in place of that adopted for the Journal. We agree that either or both, and especially both, would be improvements, and we hope to have them in time. Meanwhile we venture the explanation that our present choice is based on the desire to supply an acceptable quantity of first-class matter at a popular price. Like many another, we should have been glad

to know beforehand the value which public opinion would set upon our undertaking, but not knowing, thought best to avoid as much as possible the financial pitfalls which have engulfed so many promising scientific publications. The abundance with which subscriptions have flowed in upon us during the past two weeks and the many letters of encouragement received warrants the belief that a continuance of such support will enable us to make Vol. 2 all that can be desired both as to typography and matter.

* * *

Dr. G. Carl Huber, medical department, University of Michigan, has kindly consented to prepare a series of articles for the Journal, giving quick and accurate methods for making histological preparations and for blood staining. These articles are intended to cover the operations which the practicing physician will require in daily work, and the intention is to make them so simple that they will be readily understood, whether the reader is an advanced microscopist or not. We feel sure that this series will be very helpful to physicians and others interested in similar work and that they will therefore be of interest to a large number of our readers.

* * *

Our January edition was 15,000 copies, reaching practically every college and university laboratory in the world and every institution in which biological work is done in the United States. We therefore hope to secure for the writings of our American authors a wide recognition, and to obviate the necessity of sending their work abroad for publication. The edition for February is 16,000.

NOTES AND QUERIES.

This space is intended for inquiries regarding subjects not otherwise touched upon. Answers to inquiries will be published over the signature of the writer.

"It is desired to form a permanent collection of microscopic preparations, chiefly serial sections of embryos. It is desired to gain information from the experience of others as to what stains are the least affected by the lapse of years."

A trial of typhoid vaccine is being made on a large scale at Maidstone, England. One of the severest epidemics of typhoid ever known is now prevailing there. The experiments are under the direction of the pathological laboratory of the state army school at Netly. Professor Wright and Surgeon-major Temple have so improved the method, it is said, that they are able to obtain Widal's reaction from the blood of the vaccinated, which is taken as a proof of immunization.

Journal of Applied Microscopy.

VOLUME I.

MARCH, 1898.

NUMBER 3

Some Methods in the Study of Mature Seeds.

For some years I have studied the structure of mature seeds, more especially Leguminosae. A few suggestions on methods of procedure may be of some interest to those who wish to use the seeds of these plants to demonstrate certain histological structures. The seeds contain the macrosclerids, the form designated as malpighian, with a conspicuous cuticle and cuticularized layer. The cuticularized layer is not chemically

the same as in epidermal cells of Agave. The osteosclerids follow the malpighian and this by the nutrient or pigment

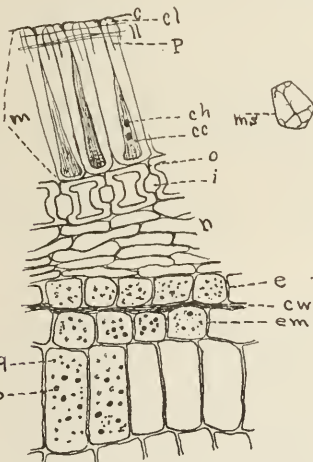

Fig. 1.—*Desmodium dillentii*, Darl.—Cross Section of Testa.

- m.—Malpighian cell.
- m. s.—Malpighian cell, surface view.
- c.—Cuticle.
- c. l.—Cuticularized layer.
- l. l.—Light line.
- ch.—Chromatopheres.
- c. c.—Cell cavity with protoplasmic remnants.
- p.—Pore canals (See surface view.)
- o.—Ostrosclerid.
- i.—Intercellular space.
- n.—Nutrient layer of thin-walled cells.
- e.—Endosperm aleurone layer.
- em.—Embryo.
- q.—Aleurone grains.
- f.—Oil globules.

X 220. (Original.)

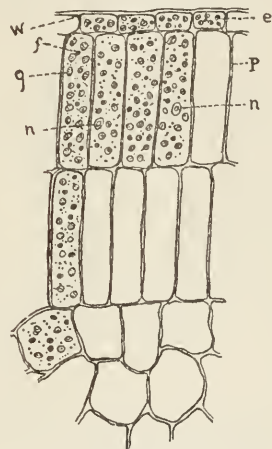

Fig. 2.—*Cassia occidentalis* L. Cross Section of Cotyledon.

- n.—Epidermal cell walls, thickened.
- e.—Epidermal cells, upper surface of cotyledon.
- p.—Palisade parenchyma.
- g.—Aleurone grains.
- n.—Nucleus and nucleolus.
- f.—Oil globules.

X 220. (Original.)

layer, then the endosperm with its usually well developed aleurone layer, and in many species, when the endosperm is conspicuous, thick walled mucilaginous cells known as the reserve cellulose—the embryo with conspicuous protein grains. The above applies well to the seed of honey locust and Kentucky coffee bean. In *Phaseolus* and *Pisum* the endosperm is restricted usually to a single layer of aleurone cells and the reserve material is found in the embryo, where it consists of starch, proteid matters, and some fat.

Gleditschia seed may be sectioned free-hand, and for this purpose the base of the razor blade should be used. It is advisable to just moisten the seed with a little water before cutting with a razor. This will prevent the otherwise brittle material from being displaced. The sections should be laid in alcohol and then mounted in water, when the mucilaginous endosperm comes out very nicely, or they may be mounted directly in potassium hydrate, which preserves the structure of the mucilage. The malpighian cells and osteosclerids can also be made out, but these layers as well as the nutrient come out better when mounted in chloral hydrate.

In order to show the nature of cell-walls in different parts of the seed, chloriodide of zinc is added to a fresh section. The secondary membrane of the endosperm colors bluish or violet, pore canals are very distinct, the protein matter of the cell cavity colors brown. The

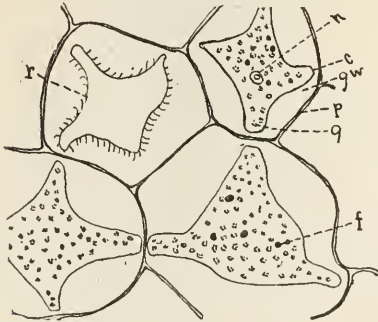

Fig. 3.—*Cassia occidentalis*, Lfl Cross Section of Endosperm (Mounted in Water.)

- n.—Nucleus and nucleolus.
- g. w.—Gelatinous wall.
- p.—Primary cell wall.
- q.—Aleurone grains.
- e.—Pore canals.
- r.—Cell wall with minute rifts.
- f.—Fat globules.

X 330. (Original.)

cell walls consist of true muclage and act as reserve matter. It is significant that the embryo contains no starch. The chloriodide of zinc reaction further indicates that the cell-walls of malpighian cells color rather tardily with this reagent. If a section is cut through the hilum and treated with phlorglucin and hydrochloric acid, the tracheid island colors red.

It is also easy to differentiate the vascular bundle in the nutrient layer. Fresh sections may also be treated with haematoxylin and aniline colors for purposes of differentiation. Ferric chloride will show the presence of tannin not only in the nutrient layer and osteosclerids but

also in the malpighian cell. The cotyledons of pea and bean are used in nearly all laboratories to study nucleus, starch, and protein grains. These are indeed excellent laboratory illustrations.

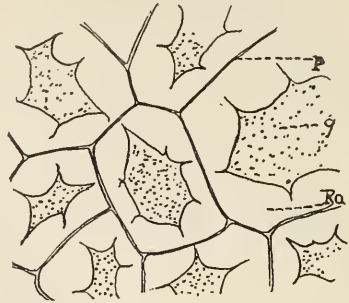

Fig. 4.—*Tamarindus indica*. Cross Section of Seed.

- r. a.—Reserve cellulose, amyloid.
- p.—Primary cell wall.
- g.—Aleurone.

X 220. (Original.)

The endosperm of date palm is commonly employed in laboratories to demonstrate reserve cellulose, but the endosperm of honey locust and Kentucky coffee bean are as valuable. Another type of cellulose amyloid occurs in the cotyledon of *Schotia latifolia* and *Tamarindus indica*. This colors blue with iodine alone. The seeds of Leguminosae present many interesting histological structures. The testa can easily be preserved without staining when mounted in glycerine jelly, glycerine, or balsam. Specimens mounted ten years ago are in excellent condition.

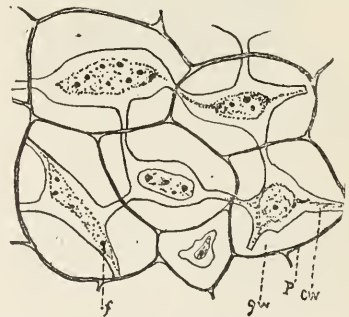

Fig. 5.—*Cassia occidentalis*. Cross Section of mucilaginous Reserve Cellulose (Mounted in Potash.)

- g. w.—Gelatinous cell wall.
- p.—Primary cell wall.
- c. w.—Cell cavity with aleurone grains and fat (f.)

X 220. (Original.)

The seeds of crucifiers may be mounted in the same way except the sections

should not be placed in water, since the walls of the epidermics are mucilaginous. The seeds of Berberidaceae can also be mounted and prepared like those of Leguminosae. It should be noted here, that the endosperm in both cases will soon become so pale that its structure can only be made out with difficulty. One section should therefore be stained either with haematoxylin or the analine dyes and mounted with the unstained preparations.

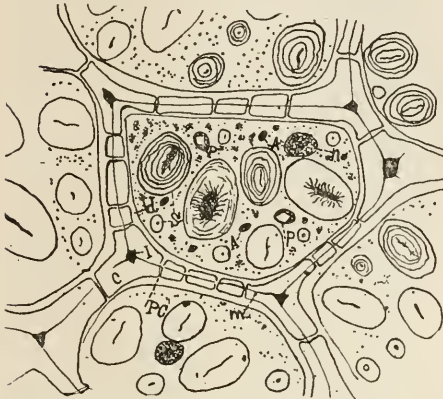

Fig. 6.—*Vigna catjang*, Walp. (cow pea.) cross section of cotyledon.

- s.—Starch grains, different sizes.
Large grains show numerous rifts.
- a.—Amyloplast.
- d.—Aleurone grain, crystalloid and globoid.
- b.—Cell wall.
- p.c.—Wall with pore canals.
- i.—Intercellular space.
- d.—Cytoplasmic membrane.
- n.—Nucleus and nucleolus.

X 220. (Original.)

Phloroglucin, so well known in laboratory work, should always be applied to testa, for in different orders variation occurs with reference to lignification. In Cucurbitaceae, the malpighian cells are lignified in Rhamnaceae only in some genera. They are not lignified in most of the Leguminosae nor in Marsiliaceae. When lignin is not present the cell-wall consists of cellulose; phloroglucin and hydrochloric acid often gives the cell-wall a bluish tinge. It is not difficult to separate the seeds of some orders by their micro-chemical behaviors and microscopic characters.

In making these studies it is essential to cut fresh sections for each test.

L. H. PAMMEL.

Iowa State College of Agriculture and
Mechanic Arts.

If pleased with the Journal give us
your support—financially.

Notes on Microscopical Technique.

G. CARL HUBER, M. D.

I have been asked by the editor of the Journal to prepare a series of short articles on microscopical technique, giving methods for hardening tissues, of imbedding them in paraffin and celloidin preparatory to cutting sections, for section cutting, for staining sections, and for making and staining blood preparations. I am further instructed to present these methods in such simple form that persons unacquainted with the most modern aspects of microscopical technique may be able to understand and use them without difficulty. The microscope has in the last few years become so essential an adjunct to the physician's equipment, such help in making a diagnosis in many of the cases met by him, that he above all realizes fully the necessity of knowing how to use this instrument properly. There are, however, many physicians who have not had time nor opportunity to acquaint themselves with the methods known to the investigators in the laboratories, who nevertheless feel a want in this direction. To meet this want, at least partially, this series of articles is prepared, and in selecting the methods to be given, I have endeavored to choose such as are easy of manipulation, not expensive and not very time-consuming.

THE HARDENING OF TISSUES FOR MICROSCOPICAL EXAMINATION.

It is hardly necessary to say that it is quite impossible to cut even moderately thin sections of the great majority of the tissues removed at an operation or at a post-mortem examination. An attempt to do so will soon convince one of the difficulties attending such a procedure. To facilitate the cutting of thin sections, to preserve as nearly as possible the relative positions of the various elements of the tissues thus sectioned, and to retain as accurately as can be the structure of these elements, various hardening or fixing fluids have been suggested. The number of such hardening or fixing fluids is now very great; some have a very wide application, others are useful in certain special examinations, others again have a very restricted field of usefulness. They all harden the tissue and all preserve more or less faithfully the tissue elements in the condition in which they were when placed in the hardening fluid. Of this number I shall mention only three, the three which seemed to me would prove most generally useful in the kind of microscopical work a physician may be called upon

to do. Before giving these methods in detail, I wish to give a few general directions which should be borne in mind in hardening tissues by any one of the methods to be mentioned.

A. It is not a good plan to wash the tissues in water before placing them in the hardening fluid, certainly not to place them in the water for the purpose of "soaking out the blood."

B. Do not handle the tissues more than is necessary.

C. Do not harden large pieces if it is desired to make sections of the tissues hardened.

It is always a good rule to have one diameter of the piece of tissue to be hardened not more than one-fourth of an inch in thickness. If it seems desirable to harden larger pieces, to show for instance the relation of a growth to the surrounding tissues, a number of parallel cuts, about one-quarter of an inch apart and passing nearly through the tissue, may be made. The parts may then be separated when placed in the hardening fluid without destroying their relative position. Small pieces are to be used because most of the hardening fluids do not penetrate readily. They harden well the outer portion of a piece of tissue, without hardening, or at least not for a long time, the middle portion.

The three hardening reagents to be mentioned are:

1. Alcohol.
2. Formalin.
3. Zenker's fluid.

1. Alcohol.—As a general hardening fluid, there is perhaps none which is so universally applicable as alcohol. Small pieces, not to exceed one-eighth to one-quarter of an inch in diameter are to be placed at once into ninety-five per cent. alcohol. The volume of alcohol used ought to be about twenty times as great as the tissue to be hardened. If less is used it should be renewed at the end of a few hours. It is also advisable to place a small quantity of absorbent cotton in the dish or bottle containing the hardening fluid. The alcohol used for hardening the tissues should be renewed every day for the first three days, and if the pieces are not large, they will be well hardened in four or five days, and may be prepared for further manipulation. (Embedding to be described in the next article of this series.) Or, if this is not possible, they should be transferred to eighty per cent. alcohol, in which they may be stored away for future use.

2. Formalin.—Formalin is a forty per cent. aqueous solution of formaldehyde gas. As a fixing or hardening reagent

it is best used in a four per cent. solution, which is prepared by mixing ten parts of formalin with ninety parts of water. This fixative, which has been in general use only a few years, seems destined to have a very wide application. It penetrates tissues very readily and preserves the elements quite well. Pieces not more than one-quarter of an inch in thickness are well hardened in about twenty-four hours. This hardening fluid should be kept in a well stoppered bottle, as it evaporates quite readily; fifteen to twenty times the volume of the tissue should be used. After hardening, that is, at the end of twenty-four hours, the tissues may be placed in eighty per cent. alcohol in which they remain until further needed.

3. Zenker's Fluid.—One of the best hardening fluids for general work is the solution known as Zenker's fluid, it has the following composition:

Bichromate of Potassium.....	5 parts
Sulphate of Sodium.....	2 parts
Bichlorid of Mercury.....	10 parts
Distilled Water	200 parts
Glacial Acetic Acid	10 parts

It is prepared by pulverizing the first three ingredients in a mortar and dissolving them in the water; the solution takes place more readily if the water has been heated. This part of the above solution may be kept on hand without deterioration. To it the proper proportion of the glacial acetic acid is to be added just before the solution is to be used. The pieces of tissue to be hardened should not be over one-quarter of an inch thick; they are well hardened in about twenty-four hours. The tissues thus hardened are now to be washed in flowing water for about twenty-four hours. This is most easily accomplished by placing the bottle containing the tissues under the tap of the sink or wash-basin, and allowing a small stream of water to run into it. To prevent the tissues from being washed out of the bottle, I have found it convenient to tie a piece of mosquito netting over the mouth of the bottle. After this thorough washing the tissues are preserved in eighty per cent. alcohol. This hardening fluid, like all others containing bichlorid of mercury, has the disadvantage of often leaving a precipitate of mercury in the tissues. This may usually be removed by adding to the alcohol into which the tissues are placed after the washing, a small quantity of the tincture of iodine. This forms with the mercury in the tissues which usually appears in the form of needle-shaped crystals, a soluble and colorless compound which is indicated by the fact that the iodine color disappears from

the alcohol. If it is desired to remove all the mercury from the tissues, the tincture of iodine should be added from time to time until the iodine is no longer removed from the alcohol, which of course is indicated by the fact that the alcohol does not lose the iodine color, that is, retains the brownish color. The following suggestions may be made as to which of the three hardening reagents to select for any given piece of tissue.

If it is desired to make a bacteriological examination, as well as a pathological diagnosis of any given tissue, alcohol should be selected as the hardening fluid.

If it is desired to harden the tissues rapidly and simply to determine the nature of the tissue, formalin will answer very well.

If, on the other hand, it is desired to make out the finer details of the protoplasm and nuclei of the cellular elements of a given tissue, Zenker's fluid should be used in preference to the other two hardening reagents mentioned.

University of Michigan.

The Coccidium Oviforme.

JOSEPH MCFARLAND, M. D.

Professor of Pathology and Bacteriology in the Medico-Chirurgical College, Philadelphia.

The epithelial cells of the livers and intestines of the lower animals are not infrequently occupied by intracellular parasites, known as coccidia. These minute organisms have been found in calves, mice, rats, cats, salamanders, centipedes, cuttlefish, and snails, and occasionally in man. In recent years not a little literature has accumulated upon the existence of rather similar organisms in the epithelial cells of carcinoma. The most common form is the *Coccidium oviforme* of Leukhart, or *P. sorospermium cucinuli* of Rivolta. This parasite is chiefly found in the rabbit, and has two principal seats of occurrence; first the liver, second the intestines. A recent epidemic of the disease which occurred in my laboratory afforded excellent opportunity for studying it, and the peculiar lesions it produces. The animals affected were young rabbits, which became acutely ill with prostration, nervous twitchings, diarrhoea, frothing at the mouth, and apparently vomiting. Within twenty-four hours the animals became moribund and died in convulsions.

Upon examining the bodies of these animals, the livers were found much increased in size, soft, dark-colored, hyperemic, and filled with small yellowish nodes of rather firm consistence and creamy contents. The nodules were

distributed throughout the liver substance equally. In one or two cases there seemed to be more of them in the small lobes than in the larger ones. They were fairly uniform in size, the extremes of variation being from a pin's head to a pea. The naked eye appearance at the first glance suggested tuberculosis, but various differences were immediately detected. The liver was deeply congested, which is generally not the case in tuberculosis. The nodes contained softened material, while tubercles are generally firm, and the nodules were discreet, not seeming to tend to form cheesy masses. When the contents of one of the nodules was examined microscopically, it was found to contain large numbers of the adult egg-shaped, permanent, encysted form of the parasite. The adult parasites are found in the softened contents of the parasitic cysts in the intestinal contents, and in consequence in the faeces. They are oval, egg-shaped, transparent bodies with granular contents, and measure from 15 to 25 by 30 to 40 μ . They are surrounded by a very delicate outer, and a very strong, double-contoured, shining inner membrane, with a small opening or micropyle at one end. The granular contents are usually of an oval or circular form, and contain a paler spot like a nucleus. Sometimes the contents of the cyst rolls itself together, leaving the poles entirely empty. The adult form bears a striking resemblance to the eggs of some of the intestinal parasites, especially the *Distoma lanceolatum*, so that in spite of our now extended knowledge upon the parasites, there are some who still regard it as a stage in the development of some worm.

When the cyst contents containing these adult parasites are fed to rabbits or injected into rabbits, or when rabbits are fed upon the livers of diseased animals, no infection takes place because the coccidia have very poor resisting powers, and are destroyed in the stomach. The propagation of the disease requires that the parasites shall be discharged from the body, and remain in moist soil. When this happens a series of changes, presumably similar to those seen in the hanging drop specimens which can be conveniently studied in the laboratory, takes place.

The central mass of granular matter is seen to divide itself into two and then into four, first round, and then elliptical fragments, each of which is surrounded by a membrane. Each of these can be properly called a spore, and in each two falciform embryos develop. The complete cycle occurs in from one to two weeks. According to the view of Rieck, when the spores are devoured

by an animal, the capsules are digested by the gastric juice, and the falciform embryos which are liberated and actively motile, pass into the intestines, where they either affect the epithelium or pass into the liver. This developmental cycle provides that from each adult coccidium eight new coccidia shall originate. When, however, the tissue lesions are studied microscopically, one is at once struck by the fact that the immense number of embryos found in the epithelial cells could not possibly have originated from this very limited multiplication, and the discovery of R. Pfeiffer that certain of the coccidia do not develop into the adult encysted form above described, but are transformed in the sporocysts, seems to be a more natural process.

According to R. Pfeiffer, a certain number of the embryos increase in size until they attain that of the encysted form, but instead of developing the surrounding resisting capsule, have their protoplasm divided up into a large number of falciform ameoboid embryos. In conjunction with this fragmentation of the protoplasm, there are numerous bizarre pseudo-karyokinetic changes, sometimes with resulting figures of almost geometrical beauty.

Ultimately, this sporocyst allows the exodus of a varying number of free, ameoboid embryos which penetrate epithelial cells in the neighborhood, sometimes more than one entering the same cell, and there perfect their existence as intracellular parasites. The microscopic appearance of the invaded tissue is of considerable interest. Each cyst has a surrounding wall lined with columnar epithelium, from which long, villous branched processes pass inward, so that a section of one of the cysts is not unlike in appearance a section of the fallopian tube, and a group of them is somewhat suggestive of the peculiar and interesting tumor known as the adeno-kystoma papilliferum. When such a cyst is scrutinized closely, it is found that the epithelium is identical with that in the neighboring bile duct, and this probably led Leukhart to investigate the origin of the cysts with relation to the biliary passages. Leukhart found that each coccidial cyst was nothing more than a distended portion of the bile duct, whose epithelium was invaded by the parasite.

The explanation of the villous processes from the wall of the cavity is not, however, so clear. Leukhart is of the opinion that each cyst is probably made up of a number of bile ducts, whose walls of separation have disappeared, and which have united to form a single large cavity, and that the villi which we

find are nothing more than the remaining fragments of the former duct walls.

It is, however, quite probable that these productions are more the result of chronic inflammation of the mucous membrane, a variety of polyposis. The epithelial cells of the mucous membrane within these parasitic cysts are almost universally invaded by the parasites, which can be found in all stages of their existence. The large parasites are quite self-evident; they form conspicuous, large, rounded granular, intracellular, nucleated, protoplasmic masses. When stained with hematoxylin, the nucleus is not very distinct. The granules become more apparent, and coarser marginal granules all around the periphery of the parasite are noticeable. The parasite in this stage varies in size from that of a normal epithelial cell to that of the adult form of the coccidia, and it would seem from this observation that the entire life history of the parasite, from its stage of appearance as a falciform embryo to that of an adult encysted form, is passed within the epithelial cells. Indeed, here and there through the cell the intracellular parasites can be found developing capsules.

It is almost impossible to differentiate the small intracellular parasites from the nuclei of the epithelial cells. Curiously enough, the small parasites have more distinct nuclei than the larger ones. When the cell is occupied by more than one parasite, they are generally of different ages. At times the parasite becomes so large that the protoplasm of the epithelial cell seems no longer able to enclose it. The parasite, however, does not separate from the cell, but remains adherent to it. The ripe coccidia which leave the cells accumulate together with cellular debris large numbers of embryos and the encysted capsules of the dead adult coccidia, in the interior of the dilated bile duct.

In the livers of the young rabbits, the lesion described is the only one that is found. In these animals the disease is generally fatal, and runs an acute course. In older rabbits, which also become infected, but not fatally, the disease runs a chronic course, and the lesions found, should the animal be killed or die a natural death from other causes, are usually much more indurated, each cyst being surrounded by a considerable massing of connective tissue, which has greatly limited the progress of the disease.

Microscopic sections of these old cysts generally show the cavity to contain the adult form of the coccidia or their empty capsules. Very often atrophy of the epithelium has occurred, and if the lesion be very old, the rabbit having survived

infection for many months, or even a year or two, no intracellular parasites can be found at all. Still later, the contraction of the connective tissue capsules diminishes the size of the cysts so that they often do not exceed the size of pin-heads or millet seed.

The developmental cycle described by Pfeiffer can only be seen in the acute cases previously described. The falci-form embryos are found with considerable difficulty; one may have to search over many fields of the microscope, in order to find any that are distinctly visible. These embryos seem to be distinctly motile, i. e., ameboid. The intestinal infection which in the rabbit is less frequent than the hepatic form, may take the form of localized patches, or may affect the epithelium of the intestines from end to end. In the coccidiosis of mice, the intestinal infection is quite a marked feature, the whole length of the intestine being generally involved. In cases of local infection the inflamed area is thickened, rather pale in color, and on microscopic section shows exactly the same character of intracellular parasitism seen in the bile ducts. Leukhart gave to the intestinal form of coccidiosis the name *coccidia perforans*, supposing that this parasite differed from the hepatic form. It seems to be rather smaller in size, measuring 13 to 20 \times 24 to 35 μ , and is characterized by less compressed form, a more rapid development of the spores (three or four days), and the formation of a permanent body. It is a question whether the two forms differ, especially when they occur simultaneously in the same host. Kruse is of the opinion that the differences are due to the organ affected, the seat of the disease. A marked difference in the aeration of the parasites of course exists, those in the liver receiving less air than those in the intestine.

Sheridan Delepine, investigating the developmental cycle described by Leukhart, was able to trace all of the developmental stages in the parasite contained in moist sand, and was able to infect animals by making them ingest the parasites in the spore-containing stage.

The coccidia are classified among the lower orders of the protozoa and differ from the gregarines by completing their life cycle within the cell, instead of leaving it to continue a free existence. They are also devoid of the worm-like shape of the gregarines, and have not their bodies divided into three layers. The protoplasm is also more uniform, and the ectosarc is thicker. They are not motile, and the symbiosis, which is so universal among the gregarines, rarely if ever takes place among the coccidia.

Their reproduction takes place solely through the formation of spores, hence they belong to that group of minute animal organisms known as the sporozoa. This sporulation, which characterizes them, has already been mentioned as occurring in a direct or indirect form; in either case the outcome of the process is the formation of sickle-shaped or serpentine, motile germs. The products of direct and indirect sporulation differ in size and shape. The probability is that the conversion of the whole coccidium into a spore is a provision of nature for the distribution of the animal from individual to individual, while the indirect sporulation, or formation of numerous sickle-shaped bodies in its interior, takes place in order to effect the infection of the individual cells of the individual host. The pathogenic power of the coccidia, as seen from this disease of rabbits which we have dwelt upon, is undoubted, and the peculiarity of the hepatic nodes has suggested to many that cancer may in all probability result from coccidial affection of the glandular, epithelial cells. The literature upon the relation of the sporozoa to carcinoma has attained voluminous proportions in the last three or four years, so that any kind of a synopsis of it would be wearying. No proofs have been brought forward by those who have inclined to the micro-organismal theory of cancer.

One important characteristic or the coccidial infections, which separates them very clearly from all the carcinomas, is the fact that the epithelial infection which takes place is always kept within bounds by the basement membrane, and that under no circumstances do the epithelial cells gain entrance into the interstices of the tissue. Could we find occasional illustration of this tissue invasion by the epithelial cells in coccidiosis, the homology between it and cancer would of course at once be evident. In its absence, however, the coccidial diseases become little more than infectious catarrhal inflammations, affecting the various weaker surfaces of the body.

Renal coccidiosis occasionally affects man. The cases that occur in human medicine are in their symptomatology not unlike those of the lower animals. In a case reported by Silcock, the illness came on about six weeks before admission to the hospital and was characterized by pains in the limbs, nausea, occasional sickness, slight diarrhoea, tenderness over the liver and spleen, temperature ranging between 101°F. and 103°F. the whole set of symptoms being ushered in with a chill. The urine was albuminous, the hepatic and splenic dullnesses

enlarged, the tongue coated with brown fur becoming dry, foul breath, and an ultimately fatal termination.

At the necropsy the liver was found to be much enlarged, weighing eighty-three ounces, and containing numerous nodules, mostly near the surface, some immediately beneath the capsule. Each was surrounded by a zone of hyperaemia and appeared quite red. The spleen weighed sixteen ounces and contained similar nodules varying in size from a pin-head to a pea. The splenic nodules were mostly larger than those in the liver and were more evenly distributed throughout the organ. In the mucous

opinion that the parasites may be of much more frequent occurrence than is thought, and points out how easily they may be mistaken for tubercles or cancer where no microscopic examination is made.

In Silcock's case, the occurrence of the lesions in the spleen was supposed to have followed the accidental entrance of the parasites into the circulation. That this is of quite possible occurrence is shown by the observation of Delepine, who found slightly altered coccidia in the hepatic veins in the neighborhood of large ulcerated psorospermic nodules, and suggests that it is from such foci that the infection of distant organs takes place.

As coccidiosus is a disease of rabbits, one would naturally think to find the source of infection in objects associated with those animals. This is, however, not always the case, for in the experience of Podwysozki coccidia were found in eggs, and Lonimski found them in association with the *Cysticircus cellulosa* in ham. There are no doubt a variety of different sources through which the spores of these parasites can enter the body.

In going carefully over the literature of the subject, I have been able to collect the following cases of human infection by the *Coccidium oviforme*:

1. Gubler (Gaz. med. d. Paris, 1858, 667). In this case the liver was the seat of the disease and contained about twenty nodes 2-3 to 20-30 cm. in diameter and innumerable small coccidial cysts.

2. Dressler. In this case the disease was also situated in the liver, where three nodules varying in size from a millet-seed to a pea were found.

3. Sattler. In this case the coccidia were found in a dilated bile-duct.

4. Perls observed two cases.

5. Virchow. This case also showed itself in the liver, where there was a cheesy tumor.

The above cases were collected by Leukhart and are published in his work, "Die menschlichen Parasiten."

6. Podwysozki. Four cases are claimed by this observer, all in the liver. (Centralbl. fur Bakt. u. Parasitenkunde, Vol. VI.)

7. Silcock. Transactions of the Pathological Society of London, 1890, p. 392. It is from this case that I have quoted so extensively.

8. Elmer (Die Ei-oder Kugelformigen Psorospermien der Wirbeltiere. Wurzburg, 1870. Elmer reports two cases in which the intestine was affected.

9. Railliet and Lucet (Traite de zoologie med. Paris, 1893). These observers found coccidia in the stools of a woman and of a child suffering from diarrhoea.

10. Kjellberg (Virchow's Archives V., 18). This case also was an intestinal one. Kruse is of the opinion that it was not the *Coccidium oviforme*, but one of the forms that are common in the cat and dog—*Coccidium bigeminum*.

11. Lindemann (Gazette med. de Paris, 1856, V., 70). In this case the coccidia were in the kidney.

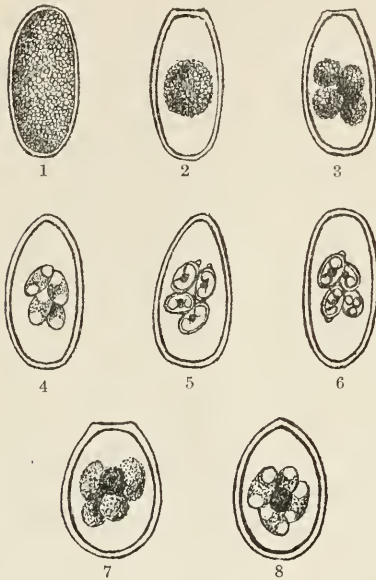

Fig. 1.

Coccidium oviforme. Developmental stages as worked out by Leuckart. 1. The ripe encysted form of the parasite. 2. Central collection of granules preparatory to the division seen in 3 and 4. Nos. 5 and 6 show the ripe spores with their enclosed embryos. Nos. 7 and 8 show similar stages of the intestinal coccidium.

membrane of the ileum were found six papule-like elevations with surrounding inflammatory zones. In the large intestine there were several interesting lesions in the form of deeply congested patches of mucous membrane from one to three inches square. In these areas the mucous membrane was infected by the parasites. A small patch of pneumonia existed in the anterior border of the left lung. The microscopic appearance of the parasite when subjected to microscopic study coincided almost exactly with that of the *Coccidium oviforme* of Leukhart. Silcock is of the

12. Railliet and Lucet (*Traite de Zoologie med.*, Paris, 1893). Coccidiosis of the kidney and ureter.

13. Kunstler and Pitres (*Jour. microg.*, Paris, 1884). This was a rather remarkable case, in which the parasites were found in the exudate of a case of purulent pleuritis.

14. Keen (*Boston Medical and Surgical Journal*, Apr. 28, 1892, and a subsequent note in the same journal, Mar. 9, 1893). This was

another case of coccidiosis of the liver, at first mistaken for an adenoma of that organ.

One of the best collections of the literature in general upon coccidia and the allied forms of animal life is to be found in the paper by Sheridan Delepine in the *Transactions of the Pathological Society of London*, 1890, XLI, p. 350.

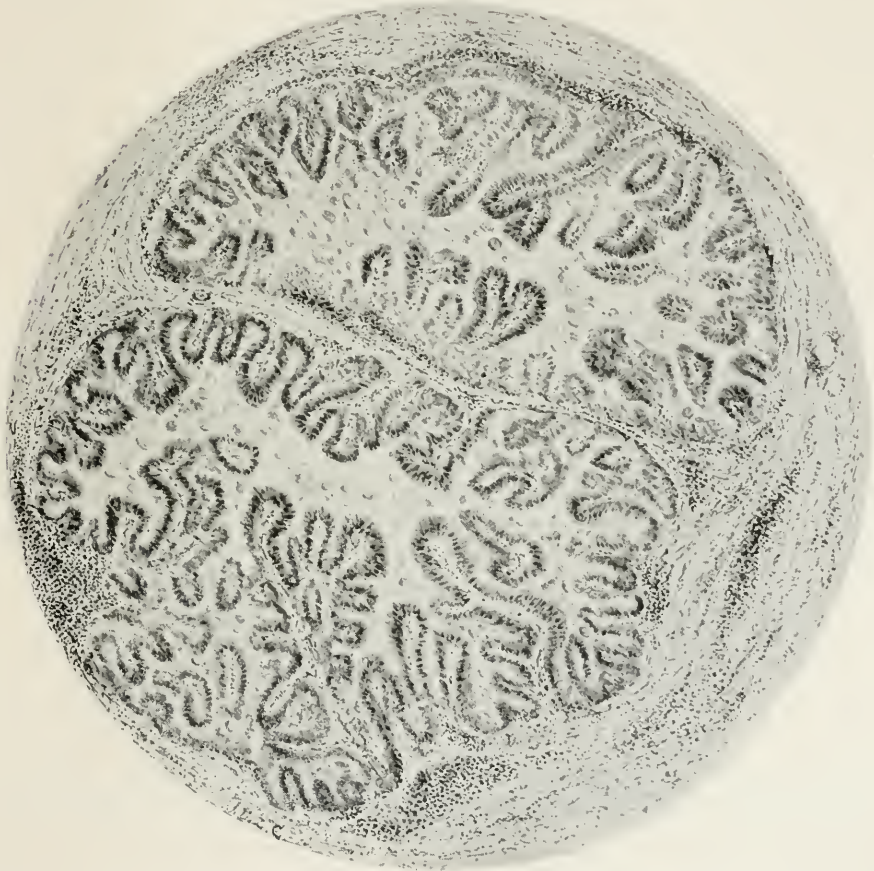

FIG. 2.

Coccidiosis of Rabbit's Liver. Section of one of the affected bile-ducts showing the papillary outgrowths from the mucous membrane, and the signs of inflammation in the surrounding tissue.

(Zeiss AA, Oc. 3.)

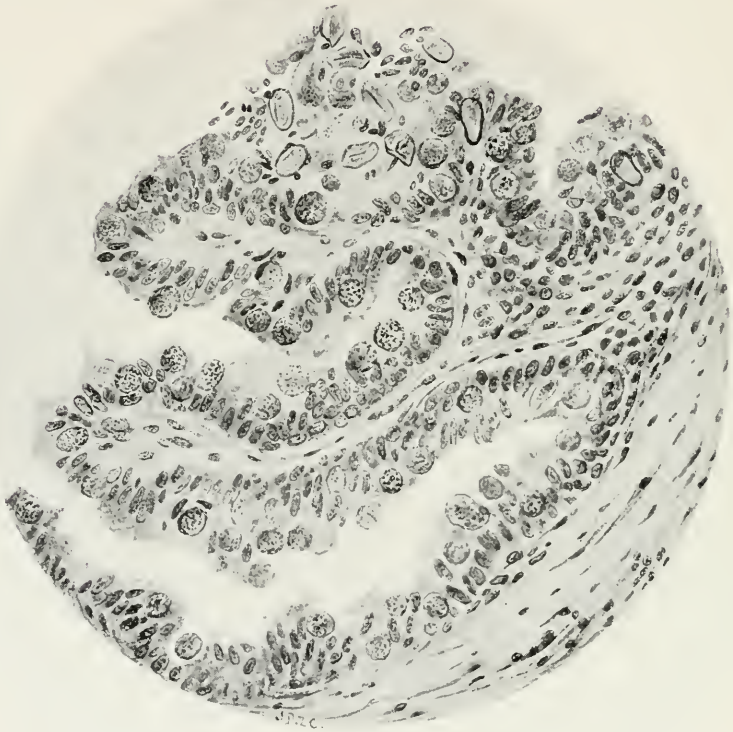

FIG. 3.

Coccidiosis of Rabbit's Liver. Papillary projections of the bile-ducts more highly magnified (Zeiss DD, Oc. 3). In the epithelial cells the rounded parasites can be distinctly seen as large granular bodies, contrasting markedly with the smaller elliptical nuclei. In the upper part of the field the encapsulated form of the parasites can be seen free among the debris between the papillae.

Mitosis Illustrated by Photo-Micrographs.

WM. H. KNAPP,
Stewart Building, Chicago.

It has scarcely been fifty years since the cell theory was first elucidated, but within this comparatively short period it has been demonstrated that the foundation of all biological problems lies in a comprehensive understanding of the cell and its vital functions.

The growth and development of the cell has therefore been most carefully studied. The subject has occupied the attention of many careful investigators, and to-day, after half a century of observation, some of the intricate processes of cell-division are as obscure as ever.

One of the methods of reproduction of the cell is by mitosis, the nucleus dividing first and the cell later.

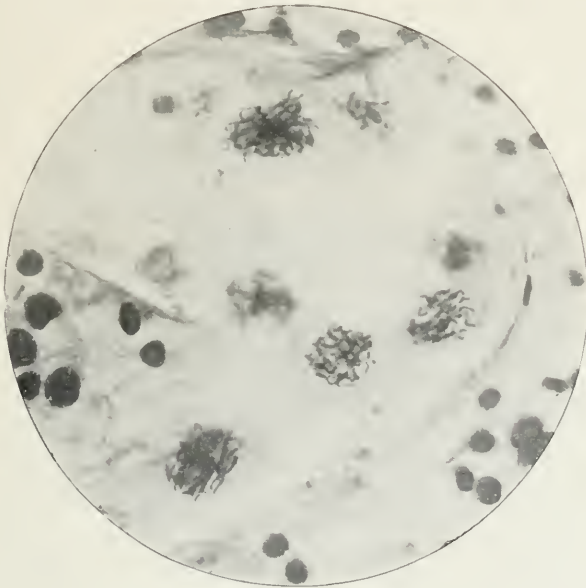

FIG. 1.

Figure 1.—This photograph is from a preparation by Dr. Charles Chamberlain of the University of Chicago. The tissue is *Lilium philadelphicum*, showing endosperm mitosis, magnified 425 diameters. In this preparation may be seen several nuclei dividing at the same time—the close and loose skein or spiren, metakinesis, and also resting nuclei. In a different plane, indicated by the blurred spots, are other nuclei in the process of division. This slide illustrates repeated division of the nucleus without cleavage of the cytoplasm.

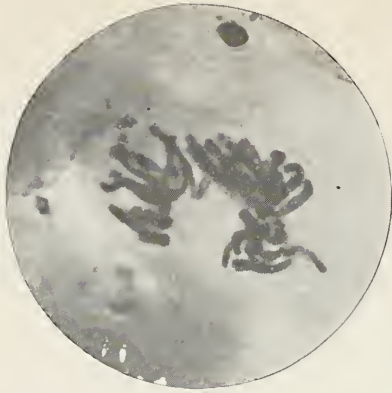

FIG. 2.



FIG. 3.

Figure 2.—This preparation is a teased one from the skin of the salamander, loaned by Dr. G. W. Webster, Chicago. The magnification is 1500 diameters. The stage of division is in the anaphase. The chromatin has partially divided into segments forming the mother wreath. The amplification is so great that some detail of the chromatin thread is discernible.

Figure 3.—This illustration is from the same preparation, and at the same magnification as figure 2. The stage of division is a later one. Segmentation of the chromatin thread has been completed and the mother wreath is fully formed. Pressure on the cover glass has flattened the cell considerably, therefore the chromatin segments probably occupy more of the cell space than they do in the cell normally.

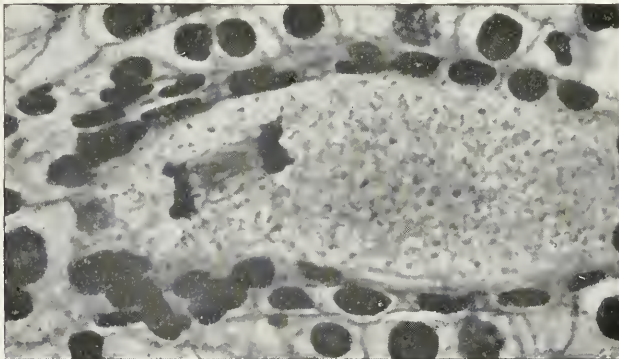

FIG. 4.

Figure 4.—This illustration is from a preparation by Dr. Charles Chamberlain of the University of Chicago, showing the first division of the macrospore nucleus in *Lilium philadelphicum*. The magnification is 425 diameters. The stage represented is one near the end of metaphase. The chromosomes have migrated to the polar fields near the position that

the daughter nuclei will occupy. The interzonal fibers are well shown. There is no indication of a transformation of these fibers into the cell plates.



FIG. 5.

Figure 5.—This illustration is from the same preparation as figures 2 and 3, and at the same magnification. The telophase is very clearly shown. Metakinesis has been completed. The chromosomes are grouped in the form, seen from the side, of the daughter wreaths. Cleavage of the cytoplasm has been almost completed. The two new cells, from the appearance of the photograph, do not contain equal quantities of cytoplasm.



FIG. 6

Figure 6.—Photo-micrograph of the first division of the ovum of *Ascaris megalocephala*. Preparation by Prof. S. Watasé of the University of Chicago; magnification, 1000 diameters. This photograph is very

interesting, as it shows clearly all of the factors of mitosis in one stage or another. The centrosomes and their centrospheres are very distinct. The chromosomes are shown in spireme stage, approaching the resting stage.



FIG. 7.

The interzonal fibers have partially disappeared, forming the four Zwischen Körper shown in the membrane between the daughter cells.



FIG. 8.

Outside of and adherent to one of the nuclei is seen the extruded polar body. The radial appearance in the archoplasm, as well as the granular character of the same, is very well shown.

Figure 7.—Photo-micrograph of the first division of the endosperm nucleus of *Lilium tigrinum*. Preparation by Mr. O. W. Caldwell of the University of Chicago; magnification, 1600 diameters. The interzonal fibers are well shown and seem to interweave at the plane of the equatorial plate. No detail in the chromosomes is shown, on account of the intense staining. Cells of the nucellus are also shown.

Figure 8.—This preparation is one of Dr. Chamberlain's, illustrating a stage in the first division of the macrospore nucleus of *Lilium philadelphicum*. The magnification is the same as in figure 7, viz., 1600 diameters. The nuclear spindle has the appearance of being bipolar. In the negative, and direct prints therefrom, may be seen at one of the polar fields a series of outward radiating lines composed of minute dots. The chromosomes are grouped in the equatorial plane. The growth of the drawing fibers of the nuclear spindle directly into the chromosome is clearly shown, and is illustrative of the theory of fibrillar contractility, by means of which the chromosomes are drawn apart along the line of the spindle fiber, leaving the interzonal fibers as shown in figure 4.

Wheat Flour in Ground Ginger.

A. MCGILL, B. A., B. Sc.

Assistant Analyst to the Inland Revenue, Canada.

The most common adulterant of ground ginger is wheat flour. The identification of this adulterant, as well as its quantitative estimation, are best made by the microscope.

Seen by plain light, the granules of ginger starch are ovoid, the markings (hilum, concentric rings, etc.) being very indistinct. In these respects they are scarcely to be distinguished from wheat starch, although the markings on the latter may be generally made out by very careful focusing and management of the light.

The most obvious distinction is the very great difference in size between the largest and the smallest of the wheat granules, while the limits for ginger starch are less wide. One does, however, find very small ginger granules, and the average size (20 to 25 Mkm.) is not far from the average size of wheat.

I have made attempts to determine the percentage in each kind of known mixtures by counting in five fields, using plain light, and have found the results very unsatisfactory, owing to the uncertainty in identifying the visible granules. The attempt also involves the expenditure of much time. When polarized light is used, a cross appears in the granules of each kind of starch; but while this is quite symmetrical in the case of wheat, it is distinctly asymmetrical in ginger. By carefully focusing

into the plane of a wheat starch granule, the granule is seen to be divided into four exactly equal portions by the dark cross; when the focal distance is a little higher or lower, the cross is still symmetrical bilaterally, and the alternate segments are alike. (Fig. 1.)

In the case of ginger starch, the cross divides the granule so that a very small segment is complemented by a very large segment, from which it is separated on each side by segments quite like each other, and intermediate in size between the first two. When the focusing is not perfect, the appearance may resemble oyster shells with the valves a little apart (Fig. 2), but the general resemblance is to a beetle with elytra expanded. (Fig. 3.)

There is no difficulty whatever in distinguishing between wheat and ginger starches seen in this way, and I have found it quite easy to determine within two to five per cent. the amount of each kind in mixtures of the two (Fig. 4) by counting the visible granules of each kind in five fields using a power of about two hundred diameters.

It is, however, less fatiguing to the eye and more satisfactory, as furnishing a permanent record of the sample, if photographs be made from carefully prepared mounts.

I have found glycerine to give the best results when the stage is used horizon-

tally; but the granules creep through the mountings again if the stage is placed vertically.

The photographs accompanying this paper were made from samples mounted in glycerine jelly. Care is needed to avoid air bubbles, and I have found it best to

distinct outline, the whole field deteriorates and a sharp negative becomes an impossibility. The non-actinism of yellow light precludes its use, otherwise beautiful contrast can be had with sodium flame. I have found that the interposition of a sheet of deep blue (co-



Fig. 1.

pass the sample after grinding through a sieve of one hundred meshes per inch, making a separate examination under a lower power, of the coarser portion, the result of this examination being taken into consideration in reporting upon the sample.

I have used an alternating arc lamp



Fig. 3.

balt) glass, very much improves the contrast, and it is with such an arrangement that the accompanying photographs have been made. I do not doubt that a cell filled with ammonia-copper sulphate would answer the same purpose, but there is a pleasure in working with dry solid materials, which makes



Fig. 2.

using fifty-two volt current and supplied with automatic centering arrangements, and the illuminating and condensing system supplied by Bausch & Lomb. Owing to the varying refrangibility of white light, an absolutely dark field is impossible, and although this is not of much consequence in ordinary work, it is very troublesome in photography; since, if the exposures be long enough to give a

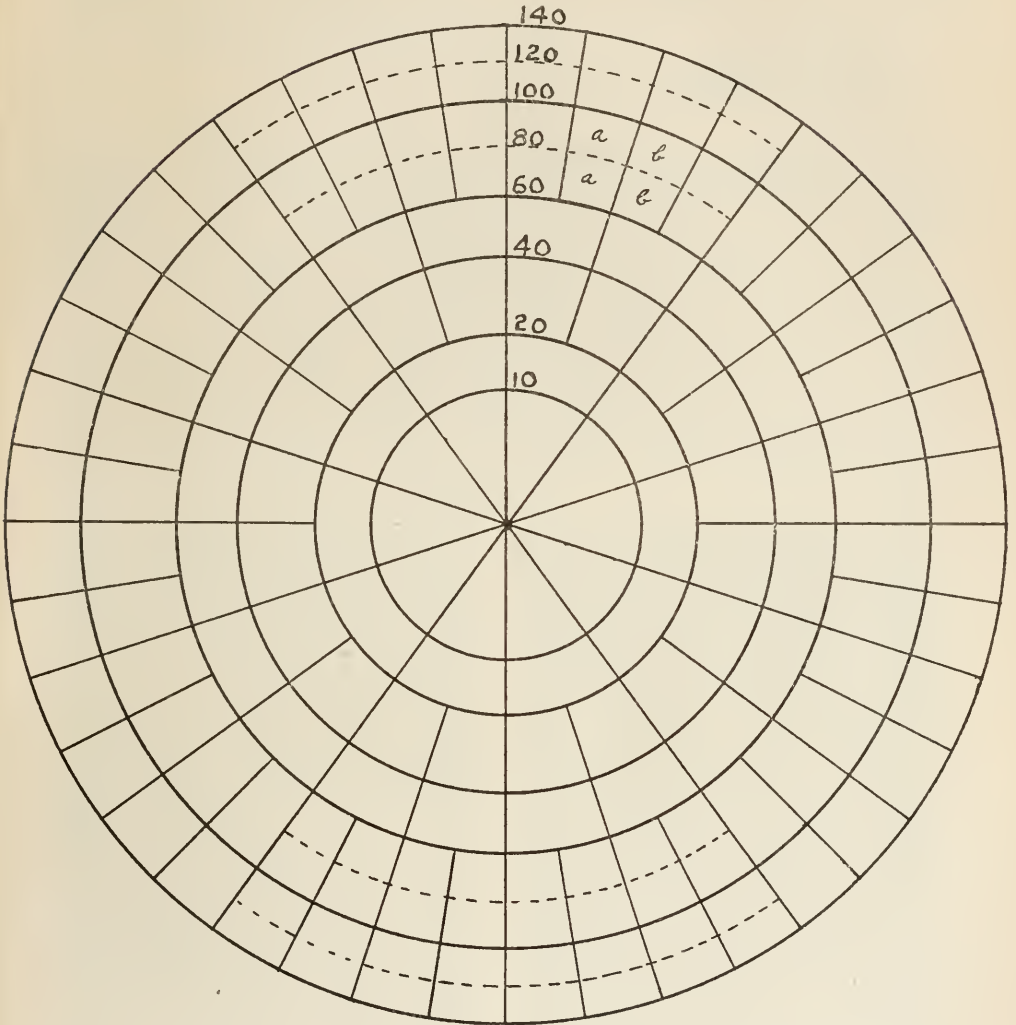

Fig. 4.

the glass preferable. The microscope is a Zeiss instrument, and I use an apochromatic of 16 mm. focus with compensating eyepiece No. 4. A camera of about 33 inches gives 225 diameters with this combination, and I find that to be a very satisfactory magnification, when a negative 4x5 is required and the field photographed is well filled.

An Apparatus to Facilitate the Counting of Colonies of Bacteria on Circular Plates.

H. W. JEFFERS.



In speaking to his students concerning the appliances for aiding one in counting the colonies of bacteria in plate cultures, Dr. Moore suggested that an apparatus similar to Park's but with the surface divided in addition to the circles and sectors into small spaces of equal area, would be especially convenient for counting the colonies on plates made in Petri dishes.

From these remarks, there seemed to be a need for an apparatus for circular

plates corresponding to the excellent one of Wolffhugel for square or oblong ones.

Acting upon this suggestion, I have constructed a figure which seems to fulfill all the requirements. It consists of concentric zones which are divided into small sections, each having an area of one square centimeter. To determine the position of the circles marked 10, 20, 40, 60, 100, and 140 in the diagram, whose areas equal 10, 20, 40, 60, 100, and 140

square centimeters respectively, the formula $\pi r^2 = \text{area}$ was used.

In order to show the application of the formula, the radius of the circle, whose area is equal to ten square centimeters, will be found from the formula as follows:

$$\pi = 3.1416$$

$$\pi r^2 = 10 \text{ or } r^2 = 10 \div \pi$$

$$10 \div 3.1416 = 3.18309 \text{ or } r^2$$

$$\sqrt{3.18309} = 1.78 + \text{ or } r$$

1.78 + centimeters equals the radius of a circle whose area is ten square centimeters. Dividing the circle into ten equal sectors, each sector has an area equal to one square centimeter.

By the same method we find the radius of a circle whose area equals twenty square centimeters, thus making each of the ten spaces between circles 10 and 20 and bounded laterally by the ten radii, equal to one square centimeter. We next construct a circle whose area equals forty square centimeters and divide each sector as far as circle 20, making twenty equal areas between circles 20 and 40, each equal to one square centimeter.

In like manner we construct circles 60, 100, and 140, dividing the sectors in the zone lying between circles 60 and 140 to produce areas equal to one square centimeter each. If a plate whose area is greater than 140 square centimeters is used, a circle whose area is 180 square centimeters can be drawn and the radiating lines extended out to the circle.

The Petri dish can be centered upon this apparatus by the circles and the area read from the line its edges approach. To facilitate the reading of the area of the plate, the circles 80 and 120, whose areas are equal to 80 and 120 square centimeters respectively, were drawn as dotted circles, thus making the areas marked "a" and "b" equal to one-half of a square centimeter. The colonies in several areas can be counted, an average taken, and the result multiplied by the number of square centimeters in each plate.

To make an apparatus to use in the laboratory there are various methods. A very good way is to make a figure of it upon tracing paper, from which a blue print can be made. In the laboratory of bacteriology at Cornell, the blue print of the apparatus is framed. It is better to have the surface of the paper a black, which absorbs nearly all the rays of light. A fine apparatus could also be made by covering a plate of glass with a uniform layer of wax, and with a sharp instrument cut the figure in the wax and subject it to hydro-fluoric acid for a few minutes, which would

etch the glass where exposed. Cleaning off the wax and placing the glass plate over black velvet the colonies of bacteria could easily be counted when the plates are placed over the surface.

From the Pathological and Bacteriological Laboratory, N. Y. State Veterinary College, Cornell University, Ithaca, New York. January 10, 1898.

A New Colonometer.

JULIUS WEISS.

This colonometer has been devised for counting colonies of bacteria on circular plates. It is based on two geometrical laws, viz., that the area of a circle is equal to πR^2 , and that the areas of two circles are to each other as the squares of their diameters.

As will be seen from the figure, the colonometer is made up of eight concentric circles and ninety-two sector circles, the last being definitely arranged within the concentric circles. The first or center circle is one centimeter in diameter; the second concentric circle has a diameter of three centimeters; the third has a diameter of five centimeters; the fourth of seven centimeters, the fifth of nine centimeters, the sixth of eleven centimeters, the seventh of thirteen centimeters, the eighth of fifteen centimeters. This arrangement of concentric circles has been made to give wide choice in working areas and to allow the use of Petri dishes of different diameters.

The concentric circles are divided into equiangular sectors by eight common radii. Circumferences 8, 7, 6, 5, 4, and 3 are again cut by eight lines, each of these lines bisecting the parts of the respective sectors that are included between these circumferences. These lines are therefore also radii, but which have not been extended in the center. The parts of the radii included between the concentric circles are used as diameters of the ninety-two sector circles; each one of the sector circles has therefore a diameter of one centimeter, which is also the diameter of the first or center circle.

The sector circles on two perpendicular diameters have been divided into eight equal sectors each, which is also the number of sectors of the center circle; the remaining sector circles are all divided into quadrants. These divisions enable the bacteriologist to do his counting in very small areas when necessary.

The counting is done as follows: An average number of colonies is found in one of the sector circles in a definite working area, and this number is multiplied by the ratio of the area of the sector circle to the area of the entire

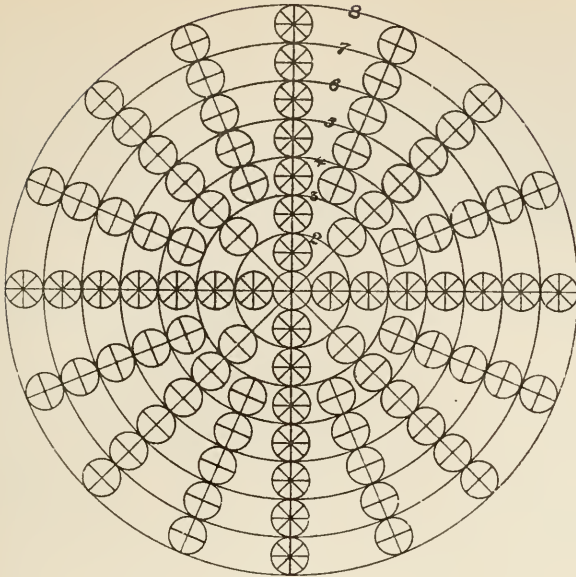

THE WEISS COLONOMETER.
ONE-HALF ACTUAL SIZE.

plate. The ratios are whole numbers as follows: Ratios between areas of circles 2:1=9; 3:1=25; 4:1=49; 5:1=81; 6:1=121; 7:1=169; 8:1=225. Areas of the circles are as follows: Area of center circle and any sector circle =.7854 square centimeters, area of circle 2=7.0686 square centimeters, of circle 3=19.6350 square centimeters, of circle 4=38.4846 square centimeters, of circle 5=63.6174 square centimeters, of circle 6=95.0334 square centimeters, of circle 7=132.7326 square centimeters, and of circle 8=176.7150 square centimeters.

Formula: (A Hypothetical Case.)

Area of plate equals that of circle 6. The average number of colonies in a sector circle=12. But ratio of circles 6 to 1 is 121; therefore the entire number of colonies on plate= $12 \times 121 = 1452$.

The calculating is evidently very simple and the colonometer is therefore of very practical value to the bacteriologist.

From the Bacteriological Laboratory of the New York State Veterinary College, Cornell University, Ithaca, N. Y.

A Holder for Collodion Imbedding.

Tissues imbedded in collodion have to be secured by collodion to a block or holder, which is then fastened in the jaws of the microtome. To prevent deposits occurring, if cork be used, and

to secure a block that will not be compressed by the microtome holder (thereby often distorting the object), wood has been recommended. The following wood holder has given excellent results and was used by the writer and his students in the botanical laboratory of the Ohio State University.

The holders are cut from basswood (*Tilia americana*) of a size adapted to the object holder of the microtome. I found very convenient blocks fifteen millimeters square and thirty millimeters long. In one end of these a hole is bored about five millimeters in diameter and not over fifteen millimeters long. Enough mercury is now poured into this hole to sink the holder in alcohol and the hole is then plugged tightly with a piece of the same wood. Another advantage of this holder is that both ends can be employed, which is a convenience when both longitudinal and cross sections are desired. A permanent number can be placed on each holder for the convenience of students in keeping track of their material in the hardening jar. No precipitates of any consequence will arise from either the wood or mercury. These blocks are best placed in weak alcohol to keep them free from air, and are then ready for use at any time.

E. MEAD WILCOX.

Laboratory of Veg. Physiology, Harvard University, Cambridge, Mass., Feb. 8, 1898.

An Osmometer and Root-Pressure Apparatus.

D. T. MACDOUGAL.

A good osmometer is essential to the equipment of every physiological laboratory or lecture room, and the demonstrative value of such apparatus is greatly increased when its action can be compared directly with that of the organism. The osmometer described below has been devised from this point of view.

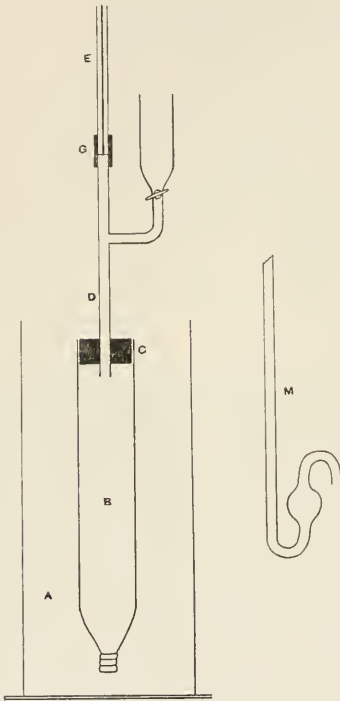

EXPLANATION OF FIGURE.

A, glass vessel containing distilled water. B, parchment cylinder, to contain sugar solution. C, stopper. D, base of connecting tube to which a separatory funnel is fused. E, capillary extension tube. G, joint made with rubber tubing wired. M, manometer tube.

The diffusion membrane consists of a section of parchment tubing twenty-five centimeters in length and five centimeters in diameter when inflated. The tubing is soaked in water for an hour, then a small portion at one end is pleated compactly, doubled back and tied firmly with cord. A perforated cork or rubber stopper is fitted to the other end and secured by a wrapping of cord. The remaining essential part of the apparatus consists of a separatory funnel fused at right angles to the short horizontal of a T tube. The lower vertical arm of the

tube is inserted in the perforation of the stopper. The upper vertical arm is joined to a capillary tube of the same external diameter by means of rubber tubing wired. This extension tube may be of any desired length. The writer uses one two meters long. Previously to the addition of the extension tube, the parchment cylinder is filled with the sugar solution or liquid to be tested, and surrounded by a cylinder filled with distilled water.

The great surface of the parchment forces the fluid upward so rapidly—about one centimeter per minute—that its movement in the capillary tube may be followed with the eye across a lecture room. A few drops of aniline dye added to the upper vertical arm of the T tube before adding the extension tube will make the column more easily visible.

The form of the parchment cylinder resembles that of a root-hair, and if the membrane is impregnated with copper salts in the usual manner, it will represent quite fairly the physical conditions of absorption by roots.

The parchment cylinder may be quickly detached, and the stump of a bleeding plant put in its place, giving a comparison with root-pressures. A manometer consisting of a U tube with a bulb in the short arm may be used instead of the vertical extension tube, and the osmotic and root-pressures may be read in terms of the mercury column.

University of Minnesota.

A Convenient Paraffin Imbedding Dish.

The following simple method of making a paraffin imbedding dish I have found very convenient. A Stender dish of the desired diameter, depending on the amount of material to be imbedded, is inverted and a piece of firm paper is wound tightly about it so that the edge of the paper projects one centimeter or more above the glass bottom. The free ends of the paper are allowed to overlap and are held together by a piece of gummed paper placed on the outside. The glass bottom of the Stender dish and the paper constitute the imbedding dish. The glass bottom of the dish is coated with glycerine, so that the paraffin block can readily be removed. When the paraffin is sufficiently cooled, invert the dish and allow water to run into the Stender dish, thereby cooling quickly the paraffin on the side next the glass. The paper can then be torn away. By its use a person can dispense with the ordinary "L's" and other appliances.

E. MEAD WILCOX.

Lab. of Veg. Physiology, Harvard University, Cambridge, Mass., Feb. 8, 1898.

Journal of Applied Microscopy.

Issued Monthly from the Publication Department
of the Bausch & Lomb Optical Co.,
Rochester, N. Y.

L. B. ELLIOTT, EDITOR.

Address all communications to
PUBLICATION DEPARTMENT,
BAUSCH & LOMB OPTICAL CO.,
ROCHESTER, N. Y.

ONE DOLLAR PER YEAR.

To Foreign Countries - - \$1.25 Per Year.

Entered at the Post-office, Rochester, N. Y., as second-class matter.

MARCH, 1898.

EDITORIAL.

Subscription remittances are acknowledged simply by sending the Journal. We shall consider it a favor if you will at once report the non-receipt of any number.

* * *

Sample copies of the January and February numbers of the Journal of Applied Microscopy have been sent to those engaged in microscopical work for the purpose of enabling them to judge of its value. We take this occasion to express our thanks to the large numbers who have favored us with their remittances, and trust that all others who desire the Journal continued will advise us at once, as no more free samples will be supplied. The material already at hand for the April, May, and June numbers is in no way inferior to and in many respects more interesting than that which has already appeared.

* * *

There are so many physicians to whom a practical microscopical laboratory appears to be of secondary importance that we cannot refrain from repeating a portion of the excellent editorial on the subject of the "Physician's Private Diagnostic Laboratory" which recently appeared in the "Journal of the American Medical Association."

The exactions of modern clinical diagnosis, through the application of pathologic and bacteriologic methods, have imposed new obligations upon medical practitioners. A few test-tubes and a spirit lamp no longer constitute a satisfactory laboratory outfit for a physician's office. To be abreast of the times, and to give his patients the benefit of the

progress in medical science, a physician who conscientiously feels his obligations must extend his laboratory practice far beyond the old confines of a search for albumin and sugar in the urine. The old microscope which has so long stood under the protection of a bell-glass, or has accumulated the dust of years in the closet, must be resurrected, not alone to search for tube-casts and spermatozoa, but to take a place beside the thermometer and the stethoscope in daily practice.

The microscope, the test-tubes, and the spirit lamp by no means constitute the requisite outfit. A number of additional pieces of laboratory equipment are required, until the office laboratory of the physician becomes a miniature chemic, bacteriologic, and pathologic laboratory. A small microtome and the centrifuge with its haematokrit are desirable; a simple sterilizer, incubator, and paraffin bath are absolutely necessary; along with such glassware as test-tubes, flasks, slides and coverglasses, and a number of reagents. It fortunately happens that, aside from the microscope and microtome, the material necessary to equip a small working laboratory for purposes of clinical diagnosis is comparatively inexpensive, providing material of a simple character be chosen.

No doubt there are hundreds of physicians over the land who appreciate more or less keenly the desirability of employing laboratory methods in medical and surgical diagnosis, and to these individuals the item of expense in laboratory equipment would offer no obstacle. More serious objections are raised, and notably the one which confesses total ignorance of the methods of modern laboratory work. Here is indeed a serious stumbling block—one, unfortunately, which lies in the way not only of the older practitioner, but also before the majority of recent graduates in medicine, who imagined while they were in college, that they were receiving "practical laboratory instruction," but who find themselves utterly helpless when the first tumor or the first case of diphtheria presents itself for diagnosis. The fault lies in an ignorance of laboratory technique which makes the would-be laboratory worker quite as helpless as one who aspired to do modern surgery while ignorant of the technique of hemostasis or of aseptic procedure.

How can this essential knowledge of laboratory manipulation be obtained? Obviously, by practice alone. This means that a reform should be inaugurated in a large portion of the laboratory instruction, as given to-day by medical schools, so that each student will be provided with a complete simple laboratory outfit, and enabled to pursue all the

steps of technical detail involved in an elementary study of such subjects as histology, bacteriology, and pathology. Moreover, for graduates in medicine, identical courses should be offered involving the various methods of a laboratory diagnosis, until the steps in manipulation and the tools required become thoroughly familiar. Post-graduate laboratory courses should be made thoroughly practical in the full sense of the word, and thus attractive; and that army of graduates in medicine who are unfamiliar with laboratory methods should avail themselves of such courses instead of haunting the surgical and gynecologic clinics, as is now the fashion. If more rural practitioners aspired to give their patients the benefit of a thorough diagnosis, and trained themselves for this purpose, the public and the profession would alike be benefited.

There is no excuse for a physician who does not prepare himself to do the work demanded in routine daily practice.

* * *

The next meeting of the American Microscopical Society will be held in Syracuse, N. Y., August 30th and 31st, and September 1, 1893.

Syracuse is the central city of New York State, with excellent railroad connections in every direction. Its hotels are among the best in the State. It is well known as a convenient city for conventions.

The society is invited to meet in Syracuse by the Syracuse Academy of Science. The daily sessions of the society will be held in the fine new building of the College of Medicine, Syracuse University. The building is centrally situated, and not far from the hotels. It has commodious lecture rooms admirably suited for the work of the society. Its laboratories are ideal rooms for trade displays of apparatus, or for a working session; and in the evening, for an exhibition soiree, which will probably be made an important part of the general program. An effort will be made to secure a small special dining room at one of the hotels, for the exclusive use of the society, to contribute to the social enjoyment of the members in attendance.

The time of this meeting has been so fixed as to make it convenient for members of the American Society for the Advancement of Science, on leaving Boston, to attend the Syracuse meeting on their homeward journey.

The Secretary of Agriculture has recently issued an order requiring that section directors of the Weather Bureau shall make themselves familiar with structural and physiological botany.

ABSTRACTS.

Method of Injecting the Urinary Tubules, etc., of Frog's Kidney.

O. FRANKL.

For the preparation of a good injection mass the author soaks ten or fifteen sheets of perfectly transparent gelatin in distilled water for twenty-four hours, when the water is drained off and the softened gelatin melted over a water bath, and an equal volume of glycerine is added and warmed with the gelatin; four to five cubic centimeters of a concentrated solution of corrosive sublimate are stirred in and the whole filtered through fine linen. For coloring the mass a solution of Berlin blue, 1-20, is added and then the mass again filtered through linen. It is injected warm, but the animal or organ need not be warmed. The mass keeps well if a thymol crystal be added.

The frog should be killed with chloroform, the abdomen opened widely, and then the frog laid in normal salt solution. For the injection the mass is warmed and the cannula inserted in the canal of Leydig (Ureter; Ductus urospermaticus) and the injection made toward the kidney. If successful the mass will fill the urinary tubules and also the spermatic ducts. The author fixes the preparations with picro-sublimate and then hardens in alcohol, and stains with alum cochineal.

If it is desired to use a red color, then carmine, 1-20, is employed instead of Berlin blue, and if the veins of the kidney are also to be injected it was shown by Hyrtl that this might be done without disturbing the urinary tubules by making a hypodermic injection into the tissue of the kidney.

(Zeitschrift für wiss. Zoologie, Bd. 63, p. 28.)

S. H. GAGE.

NOTES AND QUERIES.

This space is intended for inquiries regarding subjects not otherwise touched upon. Answers to inquiries will be published over the signature of the writer.

"It is desired to form a permanent collection of microscopic preparations, chiefly serial sections of embryos. It is desired to gain information from the experience of others as to what stains are the least affected by the lapse of years."

NOTICES AND REVIEWS.

We shall be glad to notice all books, papers, reports, bulletins, periodicals, etc., within the scope of the JOURNAL, which are sent to us for that purpose.

Journal of Applied Microscopy.

VOLUME I.

APRIL, 1898.

NUMBER 4

The Rosanilin Dyes—Their Relation to Microscopy.

V. A. LATHAM, M. D., D. D. S.

The subject of microscopic reagents, as used in our various laboratories, is one of great importance, but as yet sadly neglected; possibly for the following reasons:

(a) Many teachers avoid coloring processes as much as possible.

(b) Others use a few simple dyes, as logwood, carmine, etc.

(c) The average student, who uses the common reagents supplied by the laboratory, thinks it unnecessary to learn more than the label supplies, not being aware there may be more than one variety of the dye.

(d) The teacher often depends on some one firm to fill his orders, and trusts to their securing the article named as being suited to his work, or perhaps the belief that the title "magenta" is sufficient, there being only one variety, and that suited to all the reactions he wants.

(e) The microscopic dealers depend on the chemical firms to supply the correct article, and as they are unfamiliar with the special research, the dye is a failure.

(f) The manufacturing firm usually aims only to secure the correct color or reaction suited to the textile dyeing work, and as the profit comes from this industry, the microscopist is left out in the cold.

(g) The chemist sometimes cannot give the equation of the formula, as the coal-tar group is so intermixed and varied.

(h) The various synonyms, author's names, and modifications all tend to great confusion, and it is the use of these that should be prohibited as soon as possible.

Is the laboratory worker the only one to blame? No, because he is often unable to secure the correct name from the dealers, as they do not always know

it themselves. Again, we have small stores which put up dyes to sell, obtaining them from the local chemist, regardless of their intended use, and often the seller knows nothing of the subject.

The student must indicate the specific line of work for which the reagent is wanted, because sometimes one variety of the dye has little or no affinity for the cell structure. For example, safranin of Bindschedler und Busch in Båle gives a reaction in mucin cells, whilst safranin O of Gruebler, does not; and again, mucin in goblet cells of the small intestine in man seldom if ever stains with safranin. Similar trouble is also found in using safranin in amyloid degeneration work. Another chemical which is in sad confusion is "magenta." Text-books advise its use in yeast, blood, etc. No special variety indicated! Let us briefly note the synonyms of this dye. One author says "magenta is fuchsin or basic anilin fuchsin;" another, that "magenta is rosanilin nitrate;" a third, "magenta is acid fuchsin;" a text-book of histology, "magenta (rosanilin nitrate) is advised for staining blood and axis cylinders." This is a point gained as to variety, but one other text-book says, "No other magenta but the one known as rosanilin acetate will stain blood corpuscles," and we are told it is the same as rosein. Put these confusions before a student, and what will be the result? Failure, loss of time, expense, and much discouragement. Can we not urge the chemists to label specifically, giving the chemical name, derivation, and main value of the same? Example, magenta or fuchsin, rosanilin hydrochloride for tubercle. This briefly indicates the common name, the chemical name and its chief value.

Fuchsin is the German name and magenta the English name for the rosanilin salts, the acetate being the common variety sold to the public. For

convenience we may divide the rosanilins into:

1. $\left. \begin{array}{l} \text{Acid} \\ \text{(Fuchsin)} \end{array} \right\} \text{Acetate.}$
2. $\left. \begin{array}{l} \text{Basic} \\ \text{(Fuchsin)} \end{array} \right\} \text{Salts: } \left\{ \begin{array}{l} \text{Hydrochloride.} \\ \text{Nitrate.} \\ \text{Sulphate.} \end{array} \right.$
3. $\left\{ \begin{array}{l} \text{Neutral} \\ \text{(Fuchsin)} \end{array} \right\} \text{Picrate of Rosanilin.}$

Example, contrast produced in blood elements:

Acid Fuchsin stains deeply the most differentiated parts of cells. Red cells deeply, leucocytes faintly, nuclei not at all stained.

Basic Fuchsin stains the least differentiated parts, nuclei most deeply, body leucocytes to a less extent, red corpuscles least of all.

Anilin dyes should be called "amine" dyes, as it includes dyestuffs from naphthylamine as well as from anilin and toluidine. They are classed as:

I. Anilin.

- (a) Rosanilin group, and the most important.
- (b) Indulins and Safranins.
- (c) Oxazins.
- (d) Anilin black.
- (e) Coloring matters with sulphur (Thionins.)

II. Phenol Dyes.

III. Azo Dyes.

IV. Artificial Indigo.

V. Anthracen Dyes.

Rosanilin salts are derivatives of two hydrocarbons; triphenylmethane, $C_{19}H_{16}$ and tolydiphenylmethane, $C_{20}H_{18}$.

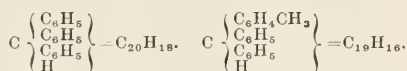

The carbon atom which joins the three benzene rings to each other is distinguished as the "methane carbon." To arrive at the value and use of this group of salts we must first briefly look over some of the technical points. If we replace one H atom by NH_2 in two or three phenyl groups, and further the H of the NH_2 group is replaced by methyl, benzyl, phenyl, etc., we obtain a series of nitrogenous compounds the value of which comes later, e. g.:

1. Diamidotriphenylmethane.
2. Triamidotriphenylmethane. (para leucine.)
3. Tetra - methyldiamido triphenylmethane. (Leucobase of malachite green.)
4. Triphenylleucaniline.
5. Pentamethylleucaniline.

These compounds, "leucobases," are colorless and yield colorless salts with acids. By oxidation they are transposed more or less readily into the color

bases, which differ from the leucobases by containing one atom of oxygen.

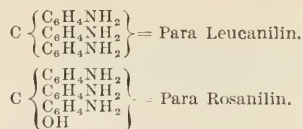

The color bases are nearly always colorless. They unite with acids, giving off water to form colorless salts, the real dyestuffs. The exact method is not well known except in the case of pararosaniline. Besides these mono-acid, colored salts, the bases yield a series of compounds containing two or more equivalents of acid, generally yellow or brown. Thus, rosanilin hydrochloride, magenta, $C_{20}H_{19}N_3HCl$, will unite with two more molecules of HCl to form the triacid salt $C_{20}H_{19}N_3 \cdot 3HCl$. This explains the behavior of the coloring matters of this group in aqueous solutions, or on fiber, towards concentrated acids, viz., H_2SO_4 , HNO_3 , etc. Decolorization takes place, but on adding water, the acid salt is decomposed and the original color is restored, as note the tubercular sputum methods. This will perhaps aid the student to remember to dip his cover in the acid and then to wash in water, which seem so easily forgotten in this work and so much more sure a test than to return to alcohol, which is sometimes advised by some teachers. Commercial anilin red is magneta, but not a uniform substance, and is a mixture of the salts of two bases. Pararosanine, $C_{19}H_{19}N_3O$ (a derivative of triphenylmethane) and Rosanilin, $C_{20}H_{21}N_3O$ (a derivative of tolyphenylmethane).

If triphenylmethane is treated with HNO_3 , the trinitrotriphenylmethane is gotten, this then treated with chromic acid gives trinitrophenylcarbinol, which when partially reduced by zinc and acetic acid is changed to pararosanine, i. e., triamidotriphenylcarbinol. The pararosanine at once unites with the acetic acid and we get acetate of pararosanine. As rosaniline is also prepared from another derivative, tolydiphenylmethane, we get a similar compound, but its action is different on tissues. Magenta is manufactured in various ways, but by the almost obsolete mercury method we obtain a very pure nitrate of rosanilin, which by double decomposition and common salt is converted also into rosanilin hydrochloride ($C_{20}H_{19}N_3HCl$). The nitrate ($C_{20}H_{19}N_3 \cdot HNO_3$) is known in commerce as azaleine when prepared by this method, hence the name given under the title of Fuchsin or Rosanilin as a synonym.

Acetate of Rosanilin ($C_{20}H_{19}N_3 \cdot C_2H_4O_2$) is the most soluble rosanilin salt, of large green crystals, which after some time turn a brownish red.

Test for pure magenta: It is decolorized by sulphurous acid while impure samples remain yellow or brown.

Acid magenta, Magenta S, Rubine S (Syn. Fuchsin S).—Säurefuchsin (which are really impure kinds of acid magenta which come on the market). Acid fuchsin is the para-rosanilinetrisulphonic acid or acid salt made by trisulphonic acids of pararosanilin and rosanilin, through heating dried rosanilin with fuming H_2SO_4 at temperature of 100 to 170 degrees. It is about half as strong

confuses with eosin), rubine, azaleine, solferino, rubianite erythrobenzine, etc. Some of the synonyms of rubin S. fuchsin are rubin S., acid magenta, säurefuchsin, acid fuchsin, fuchsin S., acid rubin, acid roseine. It is generally regarded that the dyes sold as acid rubin, acid magenta, rubin S. rosein, rose bengale (bad term as this is an eosin dye, the bluest eosin known, and especially useful to stain chromic acid hardened material), are said to give the same reactions, although different samples may vary somewhat in color. Rosein, I believe, is the acetate of rosanilin, whilst the rubin S. is the R. nitrate, though by some said to be the

COMMON NAME.	SCIENTIFIC NAME.	EMPIRICAL FORMULÆ.	CHARACTERS.
Rosanilin Hydrochloride. Para Fuchsin Rosanilin Fuchsin. Syn. Acid Magenta (B). Fuchsin (S). Acid Magenta + (M). Acid Rubin. Rubin S. (A).	Hydrochloride of Pararosanilin. Hydrochloride of Triamidotriphenyl- carbinol.	$C_{19}H_{26}N_3ClO_4$. $C_{20}H_{28}N_3ClO_4$, or $C_{20}H_{19}N_3HCl$.	Large glistening dark-green crystals, almost like Cantharides.
Acetate of Rosanilin or Para Fuchsin.	Acetate of Pararosanilin. Acetate of Triamidotriphenyl- carbinol.	$C_{20}H_{19}N_3 \cdot C_2H_4O_2$. $C_{22}H_{23}N_3O_2$.	Large green crystals. Turns to a brown color when old. Sometimes fused, green, glistening lumps, according to preparation.
Para Fuchsin. But rarely now made with acids, H_2SO_4 , HNO_3 .	Rosaniline Sulphate of Para Rosanilin. Triamidotriphenyl- carbinol. Triamidotriphenyl- nitrate.	$C_{40}H_{40}N_6SO_4$. $C_{20}H_{20}N_4O_3$.	Very fine dark green glistening powder.
Rubin. Syn.: Rosein (by B. S. S.)* Fuchsin (by E. By. M. C.) Magenta (by R. H.).	Rosanilin Nitrate.	$C_{20}H_{20}N_4O_3$.	Very fine dark green glistening powder.
Acid Magenta (B). Syn.: Fuchsin S. (B). Acid Fuchsin + (M). Acid Rubin Rubin S. (A). †	Mixture of Sodium or Ammon. Salts of Tri- sulphonic Acids of Rosanilin and Para- rosanilin.	Sodium Salts. $C_{20}H_{18}N \cdot O_{10}S_3Na_3$.	Very fine powder, magenta, bluish or greenish tint.

in dyeing as ordinary anilin red magenta.

Test, magenta. By mixing equal parts of HCl and water, magenta is decolorized and acid magenta is unaltered, though solution becomes cherry red.

Some of the synonyms for fuchsin are roseine, anilin red (a bad term, as it

* The capitals refer to special chemical firms who designate their preparation as Roseine, viz.: Brooks, Spiller, etc., of Manchester and Lincoln, England, name for Rubine.

† The acid magenta is the Rubin S. A. brand, made by Actien and Anilinfabrik in Bale, and Rubin S. is the dye of Chemic Fabrik vom Sandoz & Co., in Basel. Therefore, each dye, according to what firm bought from, is liable to give a different reaction.

acid fuchsin (R. acetate), and certainly the different dyes give different reactions if tested on pathologic or histologic material. It is of interest to remember that some of the methyl derivatives of rosanilin are methyl violet, methyl green, etc., and the phenyl derivatives of rosanilin (triphenyl-roosanilin) rosanaphthylanine, cyanin, safranin, etc., and as a neutral stain we have the picrate of rosanilin.

In using basic fuchsin, we find it may be washed out by acid fuchsin, malachite green, congo-roth, methyl green, methylen blue, vesuvin, etc., as is often seen in tubercular double staining, and gives good proof of the differential nature of fuchsin S., or säurefuchsin

and basic or rosanilin hydrochloride or hydrochlorate.

It is said that the säurefuchsin or fuchsin S is only made by the Badische Anilin und Soda Fabrik, but can be obtained through the agency of Gruebler.

Congo red, which is sometimes given as a synonym for fuchsin, is an acid variety of the same and similar to the säurefuchsin, though alkaline or neutral in aqueous solution; but it has one great difference and one that is of value in clinical microscopy, i. e., its chemical affinity for free acid, it changing to blue if the least trace be present, hence used in testing gastric juice for showing the presence of pepsin or carcinoma of the stomach. And again, we have another closely allied dye to the one just mentioned, namely benzo-purpurin, which is an acid stain, the B variety being the cheapest and best contrast dye for haematoxylin specimens, and far superior to eosin (red or blue), as it is not affected by clearing agents. Another variety of Benzo-purpurin, 6 B., is very valuable in being a highly sensitive test for HCl. and more sensitive even than Congo-roth or red.

Here we see the necessity of knowing what variety of Benzo-purpurin to order, for if we should use the B. variety for free HCl. testing, no result would be obtained, and vice versa.

Squire makes the statement that Dr. Warwick first noticed, that Rose-bengale demonstrates early amyloid. According to Lee (2nd ed.) Rose-bengale is an eosin dye of the bluest known, so cannot be grouped as a rosanilin. Gibbes, prior to 1888, used for amyloid degeneration rubin, and obtained excellent results. Here, possibly, lies the reason that other workers cannot succeed in obtaining this reaction. If rubin is understood to be the same as fuchsin S or acid fuchsin, it is different from rose bengale; but is the same as säurefuchsin, and positively, noted by Heidenhain in preparing his modification of Ehrlich-Biondi triple stain. Personally, I have dyes bought from Gruebler, Becker of London, Hopkins and Williams, London, Merck, & Shuchardt under the name of rose bengale, rubin S., fuchsin S., saeurefuchsin, and rubin acetate, and have succeeded with none in obtaining this reaction, and I used different cases of amyloid disease and in all stages. But with Becker's rosanilin nitrate I obtained excellent results. Mucin of goblet and mucous cells in vertebrates and invertebrates stains well with basic tar colors, i. e., the hydrochloride or nitrate of rosanilin, commercial fuchsin, Gruebler's neutral fuchsin (n. Unna). These few examples

will show very well the inexact method of nomenclature in the rosanilin group. Can some worker who has had more experience in one or other variety of this reagent assist in clearing the subject? Let him state the special name and value and if others will follow, we can soon tabulate this dye. The one described is by no means the only one in confusion, for Bismarck brown is confused with vesuvin; methyl blue with methylene; Ehrlich Biondi triple dye with the triacid. So much error exists in the blood stain of Ehrlich-Biondi-Heidenhain, as regards the method of making the solution, each formula calling for modified amounts, that it is rare to get an excellent stained slide where the varieties of color are seen equally well. Cabot, in his book on blood, wisely says, "The anilin colors vary so much, that it is rare to get two mixtures that stain just alike, even though made upon the same formula. Each observer must work the details out for himself after learning from some 'show specimen,' how a good stain looks." This is true, but let each writer state the correct name of the dye, the firm from whom obtained, and mode of preparation with all particulars, then we may succeed perhaps more often and be able to verify the research work of others.

Chicago, Ill.

References:

1. Roscoe & Schorlemmer, Chemistry, Organic.
2. Schultz & Julius, Survey of Organic Coloring matters.
3. Napier, Chemistry Applied to Dyeing, etc.
4. Capron, Blues and Carmines of Indigo.
5. Benedikt, Coloring matters.
6. Wagner, Hdbk. of Chem. Techn.
7. Journ. of Chemistry, etc., etc.

Agar.

Some years ago I had occasion to use a great quantity of agar for bacteriological work, and I tried many experiments in order to find some quick way of preparing it and still have it clear, as the filtering processes given in the textbooks were a weariness to the flesh. The following method gave extremely satisfactory results:

The agar—usually for from three to six liters—was prepared by cutting into small pieces, soaking until soft, washing in several waters, and picking out the scraps of foreign substances, of which there are often many. It was then put into the beef tea, which had been previously prepared according to rule, and which contained the peptone and sodium chloride. The whole was boiled in a porcelain-lined saucepan until the agar was dissolved, and during the boiling

stirred constantly and rapidly. The saucepan was removed from the fire and the solution neutralized. It was next poured into wide-mouthed jars or flasks, usually preserve jars and jelly glasses, and placed in the sterilizer, where it was steamed for two hours or more, according to convenience. Then turning off the gas, I allowed the agar to cool slowly over night without removing the cover of the sterilizer. In the morning the flocculi or sediment was found settled in the bottom in a quite compact mass. The upper portion was then removed with a spoon, or, turning the cake out of the jelly glasses, the cloudy portions were sliced off with a knife. The clear agar was then placed in the saucepan, melted and tubed, and the cloudy part, about ten per cent., thrown away.

The advantages of this method over that described by W. W. Allger in the January issue of the Journal are: (1) that by long steaming and subsequent slow cooling all the precipitate is thrown down and settles in a small space, (2) by removing the clear portions from the cold jelly there is no chance for any flocculi to pass over as there is in siphoning off the clear portions while the agar is liquid. (3) the cloudy part is so small a portion of the whole and contains so little which would pass through the filter paper, that it may be discarded with a clear conscience.

I have never found that long continued heating interfered with the nutritive value of the agar, and I have frequently steamed it for as much as six hours. By the above method I have invariably obtained clear jelly, and often so clear that when tubed it was difficult to distinguish from gelatin.

MARION HAMILTON CARTER.

Cornell University.

Some Points on the Technique of Paraffin Imbedding.

The following outline of a method for paraffin imbedding is not offered as an entirely original process. It is the result of experience in working upon various botanical studies. It is believed that it has the merits of ease and simplicity and is especially adapted for those who lack the expensive baths and ovens now placed on the market.

Success in imbedding botanical objects, which are always more or less liable to shrinkage, depends, first, upon the proper fixation of the material, and, secondly, upon gradual transfers from one fluid to another. To obviate the damage caused by too sudden transfers, have your work so arranged that something

else can be done while allowing plenty of time for each step in the process of imbedding.



Beginning with the fixed or preserved material, the first step is the staining "in toto" and the subsequent dehydration. For this process the material, if there is a large quantity and if each piece is of sufficient size to be readily seen and conveniently handled, is placed in small homeopathic vials of from one to three drachms capacity. Where a great many different lots of material are to be treated at the same time, it is advisable to have each bottle numbered, and this number may be entered at the top of a page of the note book, and under it notes made of all the different processes to which it is subjected.

When imbedding very small objects it is best to handle them as little as possible. Such material is very conveniently contained during dehydration staining and the alcohol-xyloil mixtures in small paper cornucopias made by rolling a narrow strip of paper a little diagonally, folding over the apex, and securing it with a pin. The different fluids are preferably contained in wide-mouthed bottles of at least one hundred cubic centimeters capacity. Into these the cornucopia with its contained material is directly introduced. When transferring from one fluid to another, the former fluid should be drained off by laying the cornucopia for a short time upon absorbent paper.

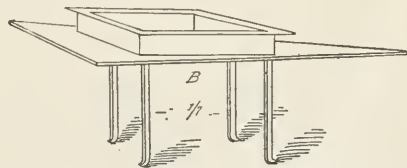

We will suppose that the material has been stained, dehydrated, and has come into pure xyloil, and is ready for the final transfer into paraffin. Flat-bottomed watch glasses are then prepared with a mixture of xyloil and paraffin. This should contain enough xyloil to render it quite soft, yet not liquid. Upon the top of this is poured a fresh layer of xyloil, and the objects are transferred from the vials or cornucopias to the

watch glasses. In this condition they may be conveniently left over night, or at least for a space of several hours.

The next step is to take the watch glasses and subject them to just sufficient heat to melt the paraffin-xylool mixture. I have found the sun's rays amply sufficient, and besides very convenient. After being thus heated for at least three hours or until nearly all of the xylool is driven off, the preparations are ready for the paraffin bath.

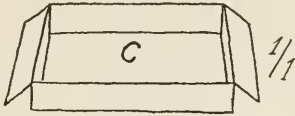

A rectangular tin box with some such dimensions as six inches long by four inches wide and one and one-quarter inches deep, provided with a sheet of glass as a cover, forms an excellent bath. This is supported upon a copper triangle eighteen inches long and six inches wide at the wider end. The heat, either gas or alcohol lamp, is applied at the pointed end, and is regulated either by moving the lamp or by moving the pan nearer or further from the heated point (fig. B). It is important to keep the paraffin about two-thirds melted, as, if the entire amount of paraffin in the pan becomes melted, there is a possibility of too great a temperature in the pan.

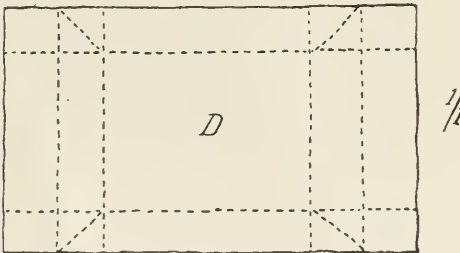

Upon the top of the melted paraffin are placed small rectangular paper boxes (fig. C). These are readily made by folding a piece of paper one and one-half inches by two inches on the lines indicated in the subjoined diagram (fig. D). This is filled with melted paraffin and into it the preparations are placed. After imbedding for from four to six hours, the objects are arranged properly in the box and the box and paraffin are lifted with forceps and placed upon a basin of cold water. In a few minutes the paraffin is hardened and the paper may be removed. Success with even the most

delicate objects may be obtained if the material is properly handled. Common causes of failure may be enumerated as follows:

(1) Too sudden transfers are made from one medium to another, therefore use a number of different grades of alcohol and many different proportions of alcohol and xylool.

(2) The transfer from the xylool to paraffin is often too sudden. To remedy this, allow plenty of time, and heat the xylool-paraffin mixture very gradually.

(3) Do not have the paraffin in the bath too hot; always have an edge of unmelted paraffin and keep the floating paper boxes close to this unmelted paraffin.

Explanation of Figures.—(A) Paper cornucopia for containing small objects (1×1). (B) Rectangular tin-box containing paraffin and resting upon a triangle at the smaller end of which the gas jet is applied (1×7). (C) Rectangular paper boxes for holding objects while in the paraffin bath (1×1). (D) Diagram for folding paper to make paper boxes for holding objects while in the paraffin.

FRANK HAINES LAMB.

Leland Stanford, Jr., University.

The Methylene Blue Method for Staining Nerve Tissues.

G. CARL HUBER, M. D.

That we have in the past few years made such notable advances in our knowledge of structure of the peripheral nervous system — peripheral nerves, sensory and motor endings, special senses, sympathetic and spinal ganglia—is in a great measure due to the fact that we have in methylene blue a stain which, when used under certain conditions, brings out these structures most clearly. It is not my purpose to review historically nor even critically the now somewhat voluminous literature bearing on this method, which, since its introduction by Ehrlich in 1885, has been used by so large a number of investigators, but rather to give briefly the methods which in a somewhat extended experience have proven most successful in my hands. I do this, not because I feel that I have materially added to the methods suggested by other writers, but because in using their methods, I have been able to sift them, and retain for my own use the ones which have proven more generally successful. I need, however, add that my observations pertain to such made on vertebrates and more particularly on mammalia. Two methods for bringing the stain in contact with the nerve-tissues are now in

general use, both are worthy of consideration:

1. Injecting the methylen blue into the blood vessels, as first suggested by Ehrlich.

2. Adding a few drops of the methylen blue solution to the living tissues, as first suggested by Dogiel and especially developed by him.

Method of injecting the solution:

A.—Solution used. In the past few years I have employed a one per cent. solution of methylen blue (Methylenblau, rectificiert nach Ehrlich. Gruebler) in normal salt. This solution is prepared by mixing in a flask one gram of methylen blue with one hundred cubic centimeters of normal salt solution, and heating over a flame until the solution becomes hot. It is then allowed to cool; when filtered it is ready for use.

B.—Injection of the stain. I have in the past few years obtained the best results by killing the animal with chloroform, and as soon as dead, exposing the main artery going to the part in which it is desired to stain the nerves. If desirous of studying the nerve endings or ganglia in the tongue, in the eye or other parts of the head, I have exposed one of the carotid arteries; if the nerve endings in the extremities, the femoral or brachial; if in the viscera, usually the aorta, other times the main artery going to the organ to be studied. A canula is then tied into the artery and the methylen blue solution injected. The amount of the solution injected varies of course with the extent of the vascular area injected. I always inject a sufficient quantity to give a light blue color to the part in which the nerves are to be studied. As soon as the blue color appears, the injection of the methylen blue is interrupted. If too much stain is injected, structures other than nerves are stained so deeply that it becomes difficult to see the nerve fibers. After the injection, the parts to be studied remain undisturbed for about one hour, after which time they are exposed, and small, or at least thin pieces are removed to a slide moistened in normal salt, and exposed to the air; and here the good sense of the observer must tell him to what extent the tissues to be studied must be divided in order to obtain the right kind of small pieces, always bearing in mind that it is necessary to bring the nerve fibers which it is desired to stain as freely as possible in contact with the air, for it has long been known that the methylen blue forms with the nerve fibers (if that expression may be allowed) a leuco-base, which is oxydized in the presence of the air into the blue stain desired. I may briefly indicate

what is meant, in this connection, by small pieces. If, for example, it is desired to obtain a preparation showing the nerve-endings in the epithelium and mucosa of the mucous membrane lining the mouth, side of the tongue for instance, it is only necessary to separate the mucous membrane from the underlying tissue and transfer it to a slide, epithelial side downward if the plexus in the mucosa is desired, mucosa-side down if the ultimate endings in the epithelium are sought for. If it is desired to obtain motor endings in striated muscle, a thin muscle like one of the eye muscles may be selected, or a larger muscle may be divided into ribbon-like pieces. If it is desired to stain the endings in and about the taste-buds, it is convenient to cut out with a double knife, from the foliate papilla, a thin strip about two millimeters in thickness. The same method may be used for nerve endings in the skin. Small ganglia may be at once removed to a slide, larger ganglia are best divided into halves with a sharp knife. It is of course understood that in each instance the parts to be studied were injected with methylen blue, as above directed, before they were removed to the slide. On the slide, the tissues remain until the nerve fibers are satisfactorily stained, that is, until the blue color has developed in the nerve fibers (axis cylinders) and their endings. This may take five, ten or fifteen minutes; usually if at the end of fifteen minutes the nerves are not stained, longer waiting does not avail much. After the tissues are removed to the slide, they are to be examined every two or three minutes to see what progress has been made. While such examinations are being made—and I refer here of course to a microscopical examination—it is best not to cover the preparation with a cover-glass. With a little care the observer is usually able to see under a low power whether the nerve fibers are stained or not, so that it is not necessary to use a cover-glass. If it becomes necessary to use a high power and consequently a cover-glass, this should remain on the tissue only long enough to satisfy the observer whether the proper degree of staining has been attained. If longer examination of the fresh tissue is desired one must be prepared to sacrifice the preparations, as they usually bleach in a few minutes when covered with a cover-glass. As soon as the nerve fibers seem to be stained, the tissues are to be placed at once in one or the other of the following fixatives. The selection of the fixative depends on the results sought for. If it is desired to gain a preparation giving the general course of nerves, the formation of plexuses, the relation of efferent

and afferent nerves to the ganglion cells of ganglia, the arrangement of the terminal fibrils in free endings and in end organs, the tissues are to be placed in a saturated aqueous solution of ammonium picrate, suggested by Dogiel. In this solution the bluish colored tissues in a short time assume a purplish color. In it they remain for twelve to twenty-four hours; are then transferred to a mixture of equal parts of the saturated aqueous solution of ammonium picrate and glycerine (Dogiel), in which they remain twelve to twenty-four hours; they may, however, remain several days without detriment. The tissues are to be mounted in the same solution. If the pieces are too large for the mounting, they may be teased, or small pieces may be snipped off with sharp scissors or they may be pressed out between slide and cover-glass or perhaps better between two slides, the top slide being replaced by a cover-glass. If, on the other hand, it is desired to work out some of the finer details, in which case it is often desirable to section the tissues, the following method, slightly modified from that given by Bethe, may be most highly recommended for fixing the stain:

Ammonium molybdate, one gram.
Distilled water, ten cubic centimeters.
Hydrochloric acid, one drop.

The solution is prepared by grinding the ammonium molybdate to a fine powder, removing it to a flask and adding the required quantity of water. The flask is now heated until the ammonium molybdate is entirely dissolved, when the hydrochloric is added. Before using this fixative it is necessary to cool it to two degrees to five degrees Fahrenheit, above zero. It is therefore well to prepare it before the injection is made, and surround it with an ice mixture. In this fixative the tissues remain for twelve to twenty-four hours. After the first six to eight hours it is not necessary to keep the fixative below ordinary room temperature. After fixation the tissues are washed for an hour in distilled water. They are then hardened and dehydrated in absolute alcohol. It is advisable to hasten this step as much as possible, though not at the risk of imperfect dehydration. The tissues are then transferred to xylol and embedded in paraffin, sectioned and fixed to the slide or cover glass with albumen fixative, and may be double stained in alum carmine or alum cochineal. After staining in either of these stains, the sections are thoroughly dehydrated, cleared in oil of bergamot. The oil is washed off with xylol and the sections are mounted in Canada balsam.

Local Application of the Methylen Blue.—In staining the nerve fibers with methylen blue by means of local application of the stain to the tissues, the following method has given me the best results. The method here given is much the same as that so successfully used by Dogiel. The tissues to be studied are divided into small pieces, such as above suggested, and are spread out on slides or in Petri dishes; the slides and dishes having been previously moistened with normal salt.

Solution used.—I usually use a one-twentieth per cent. solution of the methylen blue in normal salt solution. Of this, two, three or four drops are placed on each piece of tissue to be stained, the stain being constantly renewed as soon as it is noticed that that previously applied is beginning to evaporate. It is essential that not enough stain is added at any one time, to completely cover the tissue. It is, for instance, impossible to obtain a stain of the nerve fibers in a tissue by immersing it in the above solution. Here, as in the previous method, is essential that the air have access to the tissue while it is being stained. The length of time required to stain the nerve fibers by this method varies greatly. Sometimes they are stained in half an hour, again it may require two and one-half hours; on an average, about one hour. It is therefore necessary to examine the tissues from time to time to see whether the nerves are stained, the same precautions about covering them with a cover glass being observed. As soon as it is found that the nerve fibers are stained, the tissues are fixed in ammonium picrate or ammonium molybdate, as above described. It seems hardly necessary to add that when it is stated that the stain colors the nerve fibers, it is of course understood, as all who may have used this method know, that reference is had to the axis cylinder (neuraxis) and its branches. The dendrites of the neurons and the cell bodies of the neurons are also stained, if ganglia come within the field of observation. Before closing, a few general remarks about the method may not be out of place.

It must always be borne in mind that even an extended acquaintance with this method does not prevent one from having failures now and then. Why this is the case, I am unable to say.

It must ever be borne in mind that methylen blue, when used after either of the above methods, does not stain only nerve fibers and their endings, but also other tissue elements. Indeed, it may be said that it is almost impossible to obtain a preparation where only nerve fibers are stained. This is very often

an advantage, now and then a disadvantage. Nonstriated muscle tissue, cell body, and nucleus of the cells, stain very readily in methylen blue; so easily, that the injection method may be used with advantage in staining the muscle in the walls of vessels. Connective tissue cells are often very clearly brought out, cell body and processes coming out with a clearness which leaves nothing to be desired. Elastic tissue fibers are now and then stained with as much precision as when stained after Unna's Orcein method. Epithelial cells, especially goblet cells, and endothelial cells are often stained.

Definite rules cannot be given. The investigator is advised to vary somewhat the time interval between the injection of the methylen blue and the removal of the tissues, in some of the initial experiments; and usually some time may be hit upon, which in the greatest number of instances leads to the desired result. The method is not an easy one, one often meets with reverses, yet when all has been said, I believe it to be the most trustworthy and most satisfactory method we now have for staining the peripheral nervous system.

University of Michigan, Ann Arbor, Mich., January, 1898.

A Combination of the Paraffin and Celloidin Methods of Imbedding.

ULRIC DAHLGREN,

Instructor in Histology, Princeton University.

Several methods of combination imbedding in paraffin and celloidin have been described by Kultschizky, Ryder, Ide, Field, and Martin. I have seen or heard described several other similar methods used by Chlld, McCormick, and others.

Lee, in his "Vade Mecum," gives but scant description of the methods employed by these workers and does not recommend the process for any but those objects which are too brittle for the plain paraffin method. While not having used extensively any of the methods of the workers mentioned above, the writer has used a combination method, a development of Dr. McCormick's method, which it is believed is of much wider and more useful application than Lee accords to any similar methods. It helps in cutting brittle ova; it enables one to properly imbed the ova and embryos of amphibians which are always delicate to handle and which begin, under the plain paraffin process, to disintegrate after a short time in the water bath. In

general, it materially decreases shrinkage and minute distortions in any tissues it is used with; it enables the sections to be handled more easily after cutting and in many cases resolves cell outlines and certain achromatic structures. The process is one of extreme simplicity. The tissue is infiltrated in the usual manner with celloidin, and when it has been finally soaked in a bath of fairly thick celloidin (as thick as would be used for ordinary celloidin embedding), it is placed in a large quantity of pure chloroform, either with or without any quantity of the celloidin adhering to its outer surface. In some cases amphibian gastrulae were cut out in blocks of celloidin which was already hardened somewhat by evaporation. After remaining for twenty-four hours in the chloroform, the objects are removed to a bath of one-half chloroform and one-half cedar oil. In twenty-four hours they are placed in the water bath in paraffin of the grade that will be finally used to embed them. Several changes are necessary, and more time must be allowed than for tissues embedded by the plain paraffin method. The paraffin will be found to have penetrated the celloidin itself, and the mass cuts with much less vertical compression than in the case of objects in pure paraffin.

A little thought and experience will convince one that the method is a happy one which possesses all the advantages which belong to both the single processes of which it is a combination. This is particularly true of tissues stained in bulk. It is probably the best way of preparing for class use sections of embryos and small animals where three or four or more sections from as many regions must be mounted on a slide.

A Method of Improving Paraffin for Section-cutting.

On page 94 of Lee's "Microtometist's Vade-mecum" are statements concerning the advantage of old paraffin over that which is new that are doubtless correct.

The method here given may be a well-known one, but I have not noticed it described anywhere, and as it has been useful to me, have thought it might be to others.

It is a matter of common observation that paraffin which has been used for some time, and consequently has been melted often or for a considerable time, is better than at first if kept free from an excess of clearing agents. It has been my experience that the consistency of the paraffin generally furnished by dealers in microscopical supplies is much

improved by keeping it at a temperature somewhat above the melting point for several weeks. This is done readily by placing it in large covered evaporating dishes upon the steam radiators with which our laboratories are heated. In this way one can get a consistency at least as good as that of old paraffin and in a reasonable length of time. The tendency to crystallize is diminished and it is much less friable. There is no such change in the melting point as in the method of Graf Spee, and the results are excellent.

FRANK SMITH.

University of Illinois.

The Use of Soap for Imbedding Plant Tissues.

While engaged in a line of work requiring the sectioning of the buds of certain trees, it was found impracticable to apply either the paraffin or collodion method. The former method rendered the objects much too brittle and both methods required a longer time than could conveniently be given. At the suggestion of Professor Goodale, under whose direction the work was being done, experiments were made to determine what, if any, of the many soap mixtures could be employed. The excellent results obtained from the use of a soap-mixture in this work have prompted me to make known the details in hopes many others may find it convenient to employ the same method. It is especially adapted to work requiring only partial infiltration.

Fleming, '73, used a soap containing no glycerine, which he dissolved in strong alcohol. One fatal objection to this and all similar mixtures is that they require too long to harden. Kadyi, '79, gave a rather indefinite and complicated method of making a soap solution by dissolving in strong alcohol and then adding enough water (to be determined by repeated trial) to cause the solution to form, upon hardening, a firm mass. The uncertainty of the result by the use of this method renders it unsatisfactory. The details of this method can also be found in the *Vade-Mecum*, Lee, '93. Salensky, '77, gives an account of a method devised by Poelzam in which the soap is to be cut into pieces and exposed to the sun for several days before being employed. None of the preceding methods have proven at all satisfactory in my experience. Pfitzer, '87, recommended the use of a solution made by dissolving at sixty degrees to seventy degrees C as much glycerine soap as possible in a mixture of equal parts of

glycerine and ninety-five per cent. alcohol. This mixture, by cooling, hardens in a very few minutes so that it is firm enough to be sectioned. Poli, '89, gives a similar method of preparing a glycerine soap mixture. The latter two were used by the authors on plant tissues.

My own experience has shown that glycerine and alcohol together as the solvent give the best results. The following suggestions I hope will make the method perfectly definite and certain. I have employed Pears' Transparent Soap owing to the great uniformity of this product and the resulting superior transparency of the imbedding mass. The soap is cut into small pieces and dissolved in a mixture of equal parts of ninety-five per cent. alcohol and glycerine. For this purpose a temperature of about 70 degrees C. has proved sufficient, and the mixture while being made should be kept in a flask provided with a cotton plug to prevent too great evaporation. One gram of the soap should be used for every cubic centimeter of the alcohol-glycerine solvent. The resulting liquid is poured while warm into a petri or other shallow glass dish and there allowed to harden. This it will do by cooling in five to ten minutes. The cake thus obtained is cut into smaller pieces, which can then be stored in a bottle kept in a cool place. As this mass will keep indefinitely, a quantity can be made as directed and is then ready for use at any time.

Pieces of the prepared soap are placed in a covered glass dish (a shallow stender dish is very convenient) and the mass remains liquid at forty degrees C. The stender dish can be placed on the ordinary paraffin oven. To secure thorough penetration or infiltration it is well to place the tissues in a dilute solution, one that remains liquid at the temperature of the room for two to three hours, and then into the melted soap mass, in which the tissues should never be left longer than five to ten minutes. A longer stay in the warm solution is very apt to injure delicate tissues and cause undesirable swelling due to the alkaline character of the mixture. However, my experience has been that no difficulty in staining will occur if one removes the soap thoroughly with warm alcohol or water. Final imbedding is best accomplished in a watch glass. The mixture is very transparent and allows careful orientation of the object.

Sections are best cut free-hand with a knife moistened with dilute alcohol. The sections can, if desired, be fastened to the slide with Mayer's albumen fixative. I have employed successfully the following stains: Delafield's Haematoxylin,

Iron Haematoxylin, Bizzozzo's modification of Gram's method, Anilin-Water-Gentian-Violet, several acid fuchsin stains, and several unpublished staining methods. The following bibliography contains only those articles referred to in this paper:

BIBLIOGRAPHY.

Flemming, '73: Eine Einbettungs methode, Arch. f. mikr. Anat. 9:123-125.

Kadyi, H., '79: Seife als Einbettungs-masse beim Anfertigen Mikroskopischen Schnitte. Zool. Anz. 37: 476-479.

Lee, A. B., '93: The Microtomists' Vademecum, 3rd. Edit. 188-191.

Pfützer, E., '87: Ueber eine Einbettungs-Methode fuer Entwickelungsge-schichtliche Untersuchungen, Ber. d. Deut. bot. Gesell, 5: LXXV-LXVIII.

Poli, A., '89: Note die Microtecnica, Malpighia 3:77-84. Also see for the same, Journal Royal Microscopical Society, 835-836, 1889.

Salensky, W. '77: Ueber die Knospung der Salpen Morph. Jahrb. 3:549-602. pl. 28-30.

E. MEAD WILCOX.

Lab. of Veg. Physiology, Harvard University, Cambridge, Mass, Feb. 8, 1898.

Dehydrating and Infiltrating in a Vacuum.

ERNEST B. SANGREE, A. M., M. D.

The best microscopical work is usually that done in a methodical and rather sedate manner, but it often happens in clinical microscopy that celerity is the dominant feature, as the specimens are prepared purely for diagnosis. In the matter of a suspected growth, for instance, the surgeon sometimes wants to know instantly, if possible, what the microscope has to say. Where there is such haste, I use CO₂ freezing apparatus; and I have received a chip from a tumor while the surgeon was at work and given him a diagnosis before he had completed the operation; but this is not satisfactory microscopy.

I wish to speak of a method of rapid hardening and embedding that does give good results and gives them quickly. It is hardening and embedding in a vacuum. One of course needs good water pressure. I have a cheap pump which cost \$1.50, but the water pressure is so good that from twenty-seven to twenty-nine and one-half inches are easily gotten. In order to know just what vacuum one has, it is necessary to have a manometer. With a little glass tubing this can easily be made, and the cost is nothing. Mine consists of a piece of glass tubing about two yards long (see Fig. 1), connected at one end with a T glass tube, which in turn is connected with the pump and also with whatever apparatus is beyond, and the other end stands in a small bottle of

mercury. At the back of the glass tube is fastened a yardstick, given away by a wall-paper man as an advertisement. The whole is attached to the wall.

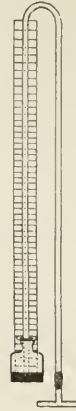

Illustration: Last evening I was handed some uterine curettings for an opinion as to the probability of cancer. An immediate report was wanted. To fix them, I put the scrapings in a mixture of nine parts of Mueller's fluid and one part formalin, a most excellent fixative. This morning the tissue was washed for an hour in running water. It was immediately transferred to a four-ounce bottle containing two ounces of absolute alcohol, and the bottle was attached to the vacuum apparatus. In two hours the specimens were hard. They were taken to the paraffin oven and put into a bottle, which can also be attached to the vacuum apparatus. Here they were allowed to stay under twenty-nine inches of mercury for two hours. At the end of that time, they were blocked, the paraffin solidified in water and sectioned forthwith. In other words, the specimen was received at 6 o'clock one evening, and paraffin sections were cut the next day at noon.

That every process was satisfactorily performed is shown by the fact that, although the specimen consisted mainly of necrotic tissue, loose fibrin, and blood clots, yet the sections cut to fifteen micromillimeters, and the staining and definition of the cells were all that could be desired.

Medical Dept. Vanderbilt University, Nashville, Tenn.

The summer course of the Marine Biological Laboratory at Wood's Hall, Mass., opens June 29th. A large attendance is expected.

Notes on Microscopical Technique.

G. CARL HUBER, M. D.

Second Paper.

IMBEDDING TISSUES FOR CUTTING SECTIONS.

In order to cut even relatively thin sections of hardened tissues for microscopical examination, it is usually necessary to imbed them in a substance, which, in a fluid state, may be caused to permeate the tissue thoroughly, and which may then be hardened to a consistency which admits of cutting readily; and this without detriment to the tissues imbedded. Experience has shown that two methods, viz., imbedding in paraffin and imbedding in celloidin, meet these requirements.

Paraffin Imbedding.—In describing this method, it is assumed that the tissues are hardened, and are in alcohol, ready for imbedding. From the hardened tissue, small, square, rectangular or triangular pieces, the surfaces of which do not exceed one-half square inch, and the thickness one-twelfth to one-eighth of an inch, are cut with a sharp knife from several places of the tissue to be studied and placed in absolute alcohol. (For this and several succeeding steps, I have found tube vials about two inches high and three-fourths to one inch in diameter very satisfactory). In the absolute alcohol the tissues remain for twelve to twenty-four hours. They are then transferred to a solution which mixes readily with alcohol and at the same time dissolves paraffin. A number of reagents may be used. I have found xylol the most convenient and most satisfactory of all. Toluol, chloroform, turpentine, cedar oil, etc., may, however, be used in place of the xylol. In the xylol—or in the other reagents mentioned—the tissues remain four to eight hours, the time depending somewhat upon the size and the density of the pieces to be imbedded. When thoroughly permeated with xylol, the tissues are perfectly transparent. If this is not the case, the xylol should be renewed and the tissues allowed to remain in it until they are transparent. If, when the tissues are transferred from the absolute alcohol to the xylol, this becomes cloudy, they should be returned to absolute alcohol for further dehydration. From the xylol the tissues are placed in melted paraffin. Two kinds of paraffin are used: a paraffin having a melting point of about 40° C.—so-called “soft paraffin”—and “hard paraffin” with a melting point of 50° C. It is obvious that, in order to have the paraffin permeate the tissue, the paraffin must be in the fluid state while the tissue is in it. It is essential, however, that the melted paraffin have a fairly constant temperature, two to three

degrees above its melting point. Otherwise, the tissues will become hard and brittle, difficult to cut, and usually suffer structural change. A fairly constant temperature may be attained in several ways. The best way is by means of a paraffin bath, the temperature of which is regulated by means of a thermostat. A simple paraffin bath, one that answers every purpose, is shown in Fig. I.

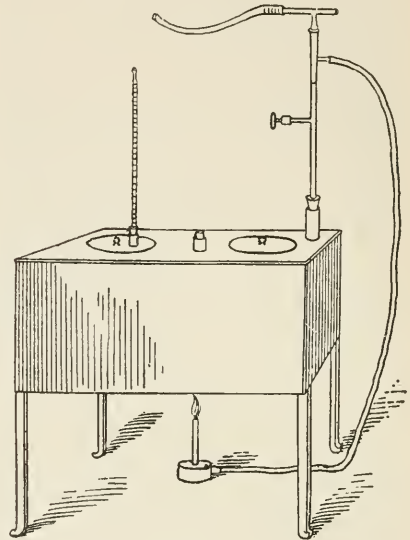

Fig. I.

The paraffin bath consists of a rectangular copper box, ten inches long, seven wide, and five inches deep. The top is provided with two cups, four inches in diameter and three and one-half inches deep, each fitted with a cover, one of which is provided with an opening about one-half inch in diameter, into which a thermometer should be fastened. The top of the glass should further be provided with two openings, three-fourths of an inch in diameter, one for the thermostat, the other for filling the bath with water. The bath rests on iron supports eight inches high. It should be provided with a false bottom of sheet iron. It may be heated with a bunsen burner and should be regulated to a temperature of 52° to 53° centigrade. The paraffin is kept in small glass beakers, the soft paraffin in a beaker in one compartment of the bath, the hard paraffin in another beaker in the other compartment, ready for use. It is essential, however, that both the hard and soft paraffin be filtered before they are used for imbedding. This may be done by melting the paraffin in a dish and pouring it into a glass funnel, which has been warmed over a flame just before using. The paraffin may at once

be filtered into the beakers kept in the paraffin bath. After the tissues are thoroughly permeated with the xylol, it is poured off and the soft paraffin added. The tube vial or other dish containing the tissues and the paraffin, is now placed in a paraffin bath in the compartment containing the soft paraffin, where it remains for two to four hours, at the end of which time the soft paraffin is poured back into the beaker containing the soft paraffin, as it may be used over and over again, and hard paraffin added; the tissues are then again placed in the bath, where they remain for four to twenty-four hours. Small pieces are usually well permeated in four hours; a longer stay is, however, not necessarily detrimental, if the temperature of the bath does not exceed the melting point of the hard paraffin by two to four degrees. The final step in paraffin imbedding is as follows: Two metallic L's are placed together on a glass or metallic plate in such a way as to form a rectangular box. Fig. II. This is filled with

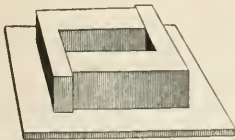

Fig. II.

the hard paraffin. Before the paraffin cools the piece of tissue to be imbedded is placed with one of its flat surfaces against one end of the box. If several pieces of tissue are to be mounted, a piece may be thus placed in each end of the box. While transferring the tissues from the hard paraffin to the paraffin in the imbedding box, they should be handled with forceps, the ends of which have been warmed in a flame. As soon as the paraffin in which the tissues are imbedded has cooled sufficiently to allow the formation of a film over the paraffin, the imbedding box is placed in a dish of cold water. This cools the paraffin quickly and prevents its crystallization. A stay of five to ten minutes in the cold water hardens the paraffin so that the L's may be removed and the paraffin box taken from the plate. It is well to place the paraffin block thus obtained back into the cold water for a while, so that it may become hard all the way through. If the rectangular box formed by the L's is about an inch long, the resulting paraffin block, containing the tissue in one or both ends, will be long enough to be clamped at once in the microtome.

If it is not convenient to have a paraffin bath, a simpler apparatus, Fig. III, viz.,

a paraffin imbedding table, may be used. This consists of a copper plate of triangular shape, about eighteen inches long and six to eight inches wide at the end, supported on three legs. A Bunsen burner is placed under the acute angle, the heat being transmitted through the metal. The hard and soft paraffins are

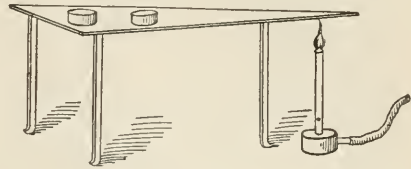

Fig. III.

placed in small glass dishes. (The paraffin should be filtered before using.) The dishes containing the hard and soft paraffin are now placed on the copper plate, and moved toward and away from the flame, until a spot is found where the paraffin in both the dishes just melts. It hardly needs to be stated, that the dish containing the hard paraffin needs to be placed nearer the flame than the one containing the soft paraffin. If the flame and plate are placed in about the same relative positions, and about the same size flames used, and currents of air are guarded against, the places where the dishes containing the hard and soft paraffin are to be placed, ascertained as above directed, will remain practically the same. As soon as the soft paraffin is melted, the tissues are taken from the xylol and placed in it, where they remain from one to two hours. They are then transferred to the dish containing the hard paraffin, in which they remain several hours. The tissues are then "blocked" in the manner above described. It is well to use small and thin pieces when imbedding in this way.

Celloidin Imbedding.—The best and most convenient celloidin to use in microscopical work is Scherring's granular celloidin, put up in one-ounce bottles. Of this a stock or thick solution is prepared by dissolving six parts of the celloidin in one hundred parts of equal parts of absolute alcohol and ether. Of this, when required, a thin solution is prepared, by diluting a quantity of the stock solution with an equal quantity of the ether and alcohol solution (equal parts).

Method of Imbedding.—The hardened tissues are cut into small pieces, which should not be much more than one-eighth of an inch in thickness and having a surface area of about one-half square inch. The pieces to be imbedded are placed for twenty-four hours in absolute alcohol; are then transferred for twenty-four

hours to a mixture of equal parts of alcohol and ether. Then they go into the thin celloidin solution, where they remain for from twenty-four hours to several days, depending on the size and density of the pieces to be imbedded. The pieces of tissue are then transferred to the thick celloidin solution, where they again remain for from twenty-four hours to several days. The hardening of the celloidin may now be obtained in one of two ways:

(a) A sufficient quantity of the stock or thick celloidin solution to cover well the tissues to be imbedded, is poured into a flat dish, large enough to allow the arranging of the pieces to be imbedded on its bottom, and leave a space of about one-fourth of an inch between contiguous pieces. The dish is then covered, not too tightly, and set aside, to allow the ether and alcohol to evaporate. In one to two days the celloidin is usually hard enough to cut into small blocks, each block containing a piece of the imbedded tissue. The blocks of celloidin are now further hardened by placing them in 80% alcohol. A stay of several hours in this alcohol is usually sufficient to give them the hardness required for section cutting. After the celloidin pieces have obtained the right degree of hardness they are to be stuck to small pieces of pine wood so that they may be clamped into the microtome. This is done in the following way: A piece of celloidin containing a piece of tissue is trimmed with a sharp knife, so that only a rim of celloidin, about one-twelfth of an inch in thickness, surrounds the piece of tissue. It is now placed for a few moments in the ether and alcohol solution. This is to soften the surfaces of the celloidin somewhat. One end of a small pine block, about one inch long, the cut end of which has a surface area slightly larger than the celloidin block, is dipped in the thick celloidin solution. The celloidin block is now taken from the ether and alcohol solution and pressed against the end of the pine block, which has been coated with the hard celloidin. The whole is now set aside for a little while, to allow the celloidin to harden slightly, and is then placed in 80% alcohol. In the alcohol it may remain indefinitely; it may, however, be used for cutting as soon as it again becomes hard.

(b) The piece of tissue to be imbedded may be mounted at once on a pine block from the thick celloidin solution, by pouring a small amount of thick celloidin over one end of the pine block and placing the piece of tissue from the thick celloidin solution onto the layer of celloidin on the block of wood. In three to four minutes, a layer of the thick cel-

loidin solution is poured over the piece of tissue and the end of the block of wood. It may be necessary to do this several times, if the piece of tissue is large or of irregular shape. The block is now set aside for five minutes and is then placed in 80% alcohol, where it remains until the celloidin is hard or until it is desired to cut sections.

As to the choice of the method to be used: In a general way it may be stated that, since the celloidin method is much easier, needs less apparatus, and answers the purpose where it is not necessary to make very thin sections, it may be recommended in preference to the paraffin method for general use in the diagnostic work which a physician may be called upon to do.

If a paraffin bath which can be properly regulated is at hand, and where it is desirable to have especially thin sections, the paraffin method is, in my opinion, always to be preferred.

University of Michigan.

(To be Continued.)

A Method of Preserving Culture Media.

Every bacteriologist and every one who has occasion for the constant use of sterilized culture media will welcome any means that succeeds in shortening the labor necessary in their preparation. One of the most onerous parts of the work is the necessity of filling fresh tubes at frequent intervals. If the tubes could be filled in large numbers and be kept unaltered for a long time, much trouble would be avoided.

Culture media do not keep well in tubes in a dry place because the continual evaporation soon changes their composition, nor in a moist place because mold spores will almost invariably find their way to the cotton and will grow through it if it is damp.

The method suggested here overcomes both of these difficulties. It consists essentially of the use of a second plug of antiseptic cotton, and is put in practice as follows:

The test tubes are cleaned and plugged in the ordinary way, except that a cotton plug of only half the usual length is used. They are then sterilized in the hot-air sterilizer and filled. Immediately after filling, the cotton plug is pushed into the tube half an inch below the top and a plug of antiseptic cotton put over it. The tubes are then sterilized in the usual way. After thorough sterilization the tubes may be closed with a rubber cap or put in closed glass vessels to prevent evaporation. Ordinary fruit jars

with a little cotton on the bottom answer very well.

The antiseptic cotton which seems best adapted to this purpose is prepared by soaking ordinary cotton in a solution of water 100, alcohol 20, and copper sulphate 3. The cotton should be dried slowly, for if heated too much it chars easily.

In a comparative experiment, about fifty tubes of agar bouillon were treated in this way, fifty left in the laboratory without any protection but the ordinary cotton plug, and fifty more with the ordinary plug put in a closed jar. In three months all of the first lot were in perfect condition; the second lot had evaporated to one-third of their original bulk, and of the third lot only one tube remained uncontaminated with mold.

There is no danger that the antiseptic will injure the culture medium for the reason that any traces which may be left on the upper part of the tube are completely wiped off in extracting the second plug.

FREDERIC T. BIOLETTI.

University of California.

On the Demonstration of Nuclear Motion in the Circulating Protoplasm of a Cell.

Chara Fragilis is selected. The plant is widely distributed in fresh, pure, quiet waters, it is described and figured in Strasburger's "Das Botanische Practicum" and in Bessey's botany. The student must acquaint himself with the bright red male reproductive organ, to be found just below the leaf; if this is crushed under the cover glass, the manubria may be seen—club-shaped cells, with brownish chromosomes but with a considerable clear space at each end. They may be known by the further fact that to the top of each the whiplash-like jointed appendages which contain the spermatozooids are attached. These manubria have a circuit of about five-eighths of a millimeter. In May, just before the ripening of the spermatozooids, the protoplasmic contents, including the nucleus of the cell, will be found in rapid circulation. I have seen the nucleus make twenty-six rounds of the cell in a minute, that is, it moves at the rate of 7.2 millimeters in a minute, or more than four times as fast as the fastest rate given for the motion of protoplasm in a cell, in Goodale's *Physiological Botany*.

D. W. DENNIS.

Earlham College, Richmond, Ind.

If pleased with the Journal, give us your support—financially.

A Preservative for Fresh Water Sponge.

I find the following solution to be of value in preserving fresh water sponge:

Pure Glycerin $\frac{3}{4}$.
3% Formalin $\frac{1}{4}$.

As every laboratory worker knows, alcohol not only takes the color from such specimens, but also from the back upon which the sponge is growing, soon becoming so discolored as to completely hide the specimen. *Spongalla viridis* was kept three months in the above solution before it lost color; the back was not attacked and the liquid has remained permanently clear, showing the external anatomy of the sponge in a beautiful manner. It remains to be seen if a weaker solution will not be even more satisfactory. Its general usefulness in preserving specimens for exhibition without decolorizing them is too well known to need comment here.

F. L. WASHBURN, A. M.

Department of Biol., Univ. of Oregon,
Eugene, Oregon.

Two Photographic Dodges.

I think it is Pringle, in his work on photo-micrography, who says that certain preparations refuse to be well photographed. Just such a preparation I have in my collection, and it is an exquisite transverse section of the human spinal cord stained with gentian violet. I tried various plates, various exposures, and various lenses, and very much patience, but all to no purpose. I could not get a clear, contrasty negative. I varied the developer, but it was of no use; the fine, delicate tracings of the nerve-fibres in the structure would be about as strong as the background of the negatives. I had heard and read about intensifying negatives—had tried it in photo-micrography as an experiment, and had given it up as rather a complicated and bothersome work, and yet this is the only remedy by which a good and even an extra-good negative can be obtained with objects of this class. I do not think that the method I use is a new one, but I claim it to be the simplest and most expeditious. I have two four-ounce bottles. No. 1, I nearly fill with water and then add a small quantity of bi-chloride of mercury (corrosive sublimate) viz., as much as will dissolve in the water. If crystals are used, one need not be particular, as only a certain quantity will dissolve, and the rest of the crystals remain at the bottom of the bottle and can be poured out when using the solution. If the pulverized

mercury is used, add a small quantity and shake the bottle until dissolved; again add some and shake, and after once making the solution, one will know about the quantity to be used. The second four-ounce bottle I fill up with three ounces of water and one ounce of ammonia. Now take a tray and place the negative in it and let it soak in water for about one minute; pour off the water, then pour the mercury solution on the negative just the same way as a developer; rock the tray gently as in developing, and watch the change in the negative. The background and all the dark part of the negative will turn white, whilst the image becomes apparent, and as all the work is done by daylight, you can take up the negative and hold it against the light for examination. Do not let the negative remain too long in the solution, as you might get too great intensity. Now pour the solution back into its bottle, as you may use it over and over until it is too weak to act, and then wash the negative and tray, and pour over the negative in the tray the contents of bottle No. 2. The negative will now turn black. The ammonia solution must be poured on the same as a developer so as to cover quickly the negative, and then rock until the negative is all black, which may be seen by examining it against the light from time to time. Take the negative out and wash in running water for about ten minutes, and then dry as usual. Try it on some of your weak negatives and see the effect it has.

The second dodge I use is with regard to lantern-slides from photo-micrographic negatives that lack contrast somewhat. The background of the lantern-slide may show up somewhat muddy on the screen. This can be remedied by using a reducing agent. I make a solution of potassic ferricyanide (red prussiate of potash) of about ten grains to the ounce of water, and two or three drops of this I add to about four or five ounces of the ordinary hypo solution, and with a camel-hair brush I apply this solution wherever I wish to clear up the lantern-slide. By being careful not to let this solution come in contact with the image, you can clear the whole of the background, thus making the image stand out more prominently, and if some of the solution gets on the image, wash quickly in water and then proceed with the clearing. If the lantern slide was overexposed or overdeveloped, and shows general fogging, then I pour the contents of the bottle into a small tray and immerse the slide in the solution, taking it out every two or three seconds, and dipping into water, so as to stop reducing. I can examine it, and if not suffi-

ciently clear, immerse again until I find the slide just what it is wanted to be. If the solution becomes too weak, add one or two drops more.

As both of these solutions are very poisonous, care has to be exercised so as not to introduce any into the body.

If by these two simple suggestions I have been of benefit to even one beginner in photo-micrography, I will feel myself amply repaid for the trouble of noting them down here.

A. M. KIRSCH, C. S. C.,
Professor of Biology.

University of Notre Dame, Indiana,

Note.—In case one wants to reduce quickly a part in the negative or in the lantern slide, add more of the ferricyanide, say a drachm to 4 drachms of hypo-solution.

Apparatus for Removing Air from Mounted Slides and Material.

D. T. MACDOUGAL.

In all work upon living material with the microscope, more or less inconvenience results from the adhesion of layers of air to the outside surfaces, or in the intercellular spaces. It is customary to remove this air by placing the preparation under the receiver of a pump. The apparatus so used, however, has been designed for other purposes and is generally bulky and awkward. The receivers are so large that the process is slow, and if a hand-power pump is used, is laborious as well.

The writer has examined the apparatus used by Berthold in his laboratory at Göttingen, which has been so useful in his researches upon the structure and mechanism of protoplasm, and the apparatus for removing air from preparations in the Leipsic Botanical Institute. The former consists of a small rectangular brass receiver countersunk in a table, large enough to hold a slide or a small watch glass, and closed with a ground-glass plate over the top. Its uses are necessarily limited. The Leipsic apparatus consists of an ordinary receiver base connected with a filter pump. The great volume of air enclosed in the long connecting tubes and the large receiver makes the process of exhaustion a very long one, and the manipulation of the valves is so complicated, that the director finds it necessary to post a set of directions or rules of manipulation, the infraction of which is punishable by a stated fine of two to five cents for each offense.

The apparatus that has been found most useful, in my courses in the physiology of the cell, consists essentially of a tubular metal receiver connected with a filter pump by a metal tube containing a

three-way valve and a short section of rubber tubing. The receiver is made from a section of heavy brass tubing ten centimeters long and three centimeters in external diameter. The open end is closed with a piece of ground glass 4x4 centimeters. The base of the receiver is fitted to an L-shaped connecting tube of convenient length. This tube is furnished with a three-way valve, which will give a straight connection between the pump and the receiver, between the pump and the open air, or will close all of these connections. The second arm of the L may be fastened to a wooden base or the wall by means of a staple, or, better, by means of two wooden blocks and a metal strip as shown in the figure. The tubing connecting with the filter pump should be no longer than absolutely necessary, since the smaller the amount of enclosed air the more rapidly will exhaustion be accomplished. When the receiver is in an upright position, as shown in the cut, a small bottle containing material may be inserted, or the receiver may be brought down to a horizontal position and a mounted slide inserted. The change of position can be made instantaneously.

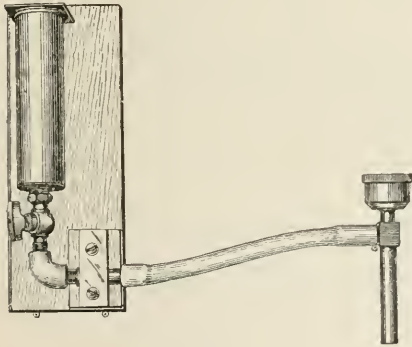

This apparatus is very effective and rapid in its action, since the full exhaustion power of the pump is used inside of two minutes, and the only precaution necessary before removing the material is a half turn of the stopcock. If the pump should be stopped when the way into the receiver is open, water will be drawn into the chamber. This is true of all receivers exhausted by water pumps, however.

The apparatus described above with a filter pump can be constructed for five dollars or less.

University of Minnesota.

New applications of old methods should be sent to the Journal.

An Improved Form of Wash-Bottle for Microscopists.

The accompanying cut represents a form of wash-bottle which has been in constant use in my laboratory for the past year, and has given great satisfaction.

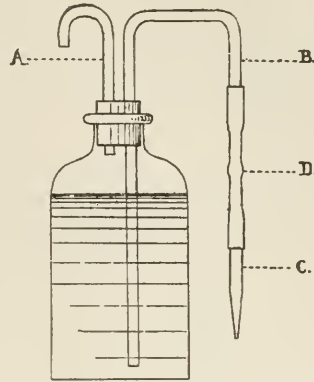

It was devised by Mr. A. L. Winton of the chemical department of this station, and I am indebted to his courtesy for permission to publish the following description of it. The principle employed is that of the siphon, and the apparatus consists essentially of a wide-mouthed bottle fitted with a rubber stopper, through which two glass tubes pass, the one, "A," serving to admit air, the other, "B," to secure a flow of water. One end of the latter extends downward to a point near the bottom of the bottle, the other is cut off about on a level with the stopper and is connected by means of a piece of rubber tubing with a short section of glass tubing, "C," which is drawn out into a fine open point. The rubber tube is about two inches long and into it is forced a solid glass bead a trifle larger than the inside diameter of the tube "D." A ball-cock is thus formed such as is used in a burette. The bottle having been filled with water and the stopper and glass tubes adjusted, the rubber tube with the bead inserted at its middle point and the nozzle connected with its lower end is connected with the end of the discharge tube, whereupon a slight pressure on the bead and simultaneous suction at the nozzle serves to fill the siphon and the normal atmospheric pressure maintains this condition. To secure a flow of water all that is necessary is to apply pressure between the thumb and finger upon the rubber tube immediately over the bead "D." The walls of the tube are thus expanded in a direction at right angles to the plane of pressure, the water flows past the bead and is deliv-

ered from the nozzle in single drops or in a steady stream according to the degree of pressure exerted upon the tube over the bead. In preparing this apparatus I have used glass tubing measuring 7-32 inch outside diameter, and red or antimony rubber tubing measuring 5-32 inch inside diameter. The bead can easily be made from a piece of glass rod, and should, as I have said, be made a trifle larger in diameter than the inside diameter of the rubber tubing. It should also be as nearly circular as possible, at least in one plane, in order to close the tube tightly and uniformly.

The advantages of this apparatus are: (1) that the bottle is fairly germ-proof and might be made entirely so by plugging the tube admitting air with cotton, the water thus maintaining its purity unimpaired if it be originally distilled; (2) that the disagreeable results which attend the constant use of an ordinary wash-bottle where the lips are applied to one of the tubes, are entirely obviated; (3) that the flow of water is under perfect control; and (4) that it renders unnecessary the constant shifting of the bottle from place to place. The bottle remains stationary and the slide is placed under the nozzle, which may be adjusted to any height desired by raising or lowering the discharge tube. The whole apparatus is of simple construction and may be made very durable by using a bottle of heavy glass.

W. C. STURGIS.

Connecticut Agricultural Experiment Station, February, 1898.

A Marker for the Microscope.

Several years ago, having need of a marker for use in certain work which was then going forward in my laboratory, I made some rough sketches from which the university mechanic made a somewhat clumsy but very useful attachment to the microscope. It has since been used successfully by many workers and may be fairly said to accomplish its purpose. The accompanying drawings will enable any one to understand its construction, and if he is able to handle tools make one for himself.

It consists of a base "C," having on one side a screw thread "B," by which it may be attached to the nosepiece of the microscope. Through this base a sunken screw, "A," fastens to the revolving plate "D," which in turn carries the grooved post "H." Over this post there is slipped the adjustable collar "F," which is tightened and held in place by the set screw "E." The small camel's hair brush "G" is slipped between the

post and collar in a position opposite to the set screw, as shown in Fig. 3, where it is exactly in the axis of the microscope. It is obvious that if now the plate

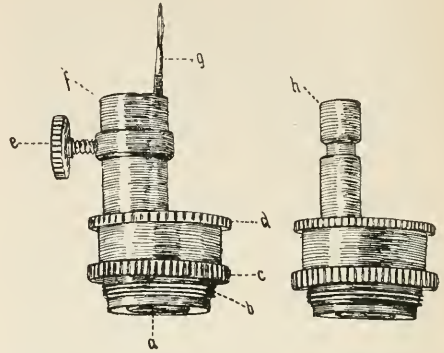

Fig. 1.

Fig. 2.

Fig. 1.—The marker complete, with brush "G" in place. Fig. 2.—The same with the adjustable collar "F" removed.

"D" be rotated the brush will make a revolution upon its own axis, but if the position of the brush be changed by rotating the collar upon the post, then a rotation of the plate "D" will cause the brush to rotate around an axis at a greater or less distance from it. In other words, the brush will describe a circle of greater or smaller dimensions. In using it our practice has been to attach the marker to the double or triple nosepiece of the microscope, and whenever an object was to be marked, to bring it exactly into the center of the field and then to swing the marker in place of the objective, racking it down so that the brush touched the cover glass lightly, then with a careful turn of the plate "D" to run a ring around the object. We have used asphalt thinned with turpentine, and find it to be quite satisfactory. Care must be taken not to apply too

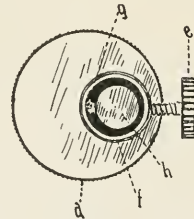

Fig. 3.—Top view of Fig. 1.

much asphalt, and special care must be taken to have the brush well pointed, otherwise the asphalt ring will be broad and unsightly. Of course these rings must be made of larger or smaller dimensions, to suit the object which they serve to mark.

CHARLES E. BESSEY.

University of Nebraska.

A Makeshift Photo-Micrographic Apparatus.

GEO. D. FIRMIN.

Many persons interested in photography and also in microscopy are deterred from combining the two on account of the expensive apparatus supposed to be necessary. A special outfit, so far as ease of manipulation is concerned, is undoubtedly preferable to makeshift appliances. Good work can, however, be done with the latter, provided one works intelligently. In the following description I suppose the possession of a microscope and a camera box. As a matter of fact, a camera is not necessary, as any tight box adjusted to receive a plate-holder is sufficient. In my own case, as I happened to pos-

The condenser "F" is placed on the same block, or may stand to one side provided the lens centers accurately with the microscope.

The illumination is by a Welsbach light. "H" is a sheet-iron chimney provided with a slit covered with cobalt blue glass. It is necessary that the whole be accurately centered or distortion will result. The microscope is focused by a thread "T" passing around the fine adjustment head, through the eyelets "S" and "S," and terminating in weights conveniently placed near the hand. By this means high-power objectives may be focused with comparative ease. That the microscope may always be in line with the rest of the apparatus, it is well to tack short strips of wood to the block "N" to serve as

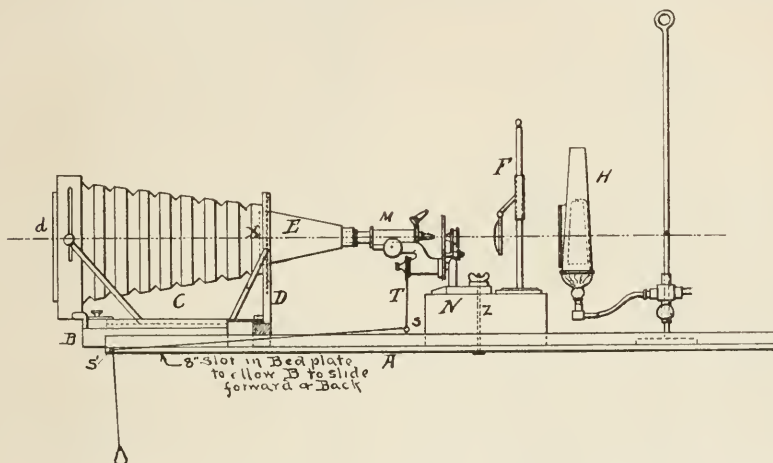

sess an 8×10, I used it with kits and 4×5 plates. A 4×5 camera would be much more easily arranged. The sketch will almost explain itself. "A" is the bed plate, consisting of a pine board three feet six inches long by nine inches wide with side strips or guides one-half inch by one inch high. In the center of this is a row of one-quarter inch holes, two and one-half inches apart. These are to receive the clamping pin in "Z" (a small carriage bolt) to hold the microscope steady. "B" is a sliding piece nine inches by twelve inches, to which is screwed the camera body "C." The front "D" is fixed in position by a clamp passing through one of the holes in the bed, so the back "d" is used to focus. "E" is a cone of cardboard lined with black paper and having a piece of mailing-tube lined with felt or velvet fixed in its small end to fit over the microscope tube. The microscope "M" is clamped to a wooden block "N" to raise it to the proper height to center with the camera.

guides. Any size plate may be used, but a 4×5 is most convenient.

A color screen or Bausch & Lomb bichromate cell will often be of service. Not possessing the latter, I have used with considerable success a carbott aurantia screen set in slides in the camera front "X." If a screen is used it is well to use a plain glass slide instead of cobalt glass in front of the light.

With high-power objectives, as one-twelfth inch oil immersion, long exposures are necessary. Care must then be taken not to jar the outfit, as the slightest touch will throw it out of focus. If a camera box be improvised, I would suggest that the ground glass be hinged so as to swing out of the way and allow the plate-holder to take its place. If the glass is spring-actuated, there is considerable jar in adjusting the plate-holder and the result is loss of focus. A cover glass cemented to the center of the ground glass is a help in fine focusing.

Journal of Applied Microscopy.

Issued Monthly from the Publication Department
of the Bausch & Lomb Optical Co.,
Rochester, N. Y.

L. B. ELLIOTT, EDITOR.

Address all communications to
PUBLICATION DEPARTMENT,
BAUSCH & LOMB OPTICAL CO.,
ROCHESTER, N. Y.

ONE DOLLAR PER YEAR.

To Foreign Countries - - \$1.25 Per Year.

Entered at the Post-office, Rochester, N. Y., as second-class matter.

APRIL, 1898.

EDITORIAL.

So many requests for the publication of matter of a more elementary nature than has heretofore appeared in our pages, have reached us during the past month, that we have decided to introduce a department devoted to elementary microscopical technique.

The papers by Dr. G. Carl Huber, which began in the March issue, are a fair sample of what we expect to do in this line. Dr. F. G. Novy, University of Michigan, will, later, contribute some practical directions for staining and mounting the most commonly met with pathogenic bacteria. We will also have papers on preparing and mounting rock sections, insects, botanical sections, etc.

This department will in no way interfere with the general character of the Journal, but may be regarded simply as an addition to it for the benefit of a large number of our readers who are not specialists.

* * *

The writers of recent biological text-books for use in secondary schools rarely deem their work complete without the addition of an appendix informing the instructor what, in the author's opinion, is the best apparatus for the equipment of a laboratory, where it can be had, and the lowest rate at which it can be obtained. The idea itself is, in the main, a good one, the exception being the quotation of prices. The prices of six months ago are not the prices of to-day, and we venture the assertion that even the manufacturers would hesitate to predict what the prices will be six months hence. We are, therefore, forced to the

conclusion that such information is of little value for the purpose intended and might better be omitted, especially since it is liable to prejudice the public without cause against apparatus which might otherwise be used with profit and satisfaction. Text-book writers might well bear in mind the fact that, since improvements in apparatus occur almost daily, while text-books undergo revision at comparatively long intervals, statements regarding the adaptability or non-adaptability of any particular make should not be too positive.

* * *

The International Health Exposition will be opened in the Industrial building, Grand Central place, New York City, April 25th, and continue until May 31st. The exposition is intended to show the progress made in the solution of sanitary problems in every field of sanitary work. The principal departments of the exposition are domestic sanitation, municipal hygiene, food products, health resorts and sanitariums, hygienic literature, sanitary organizations, military and naval hygiene, animal sanitation, industrial hygiene, preventive medicine, fire protection, etc. In connection with this exposition, it is desired to make an exhibit of microscopical preparations, showing the bacterial causes of disease, the effects of various kinds of labor on the organs of the body, for example, deposits of substances in the lungs, and of adulterated food products. Sets of two slides, one showing pure and the other adulterated foods, are suggested. Lantern slides will also be required and may be of any subjects illustrative of the causes and effects of disease due to imperfect sanitation, unhealthful occupation and the like.

Any such exhibits may be forwarded to the Journal of Applied Microscopy, and we will be responsible for the safe return of same after the exposition. Each specimen will be exhibited under the name of the sender and credit given for lantern slides, etc., used. Exhibits should reach Rochester as early in the month as possible.

NOTES AND QUERIES.

This space is intended for inquiries regarding subjects not otherwise touched upon. Answers to inquiries will be published over the signature of the writer.

A simple method of demonstrating the circulation in the mesentery of the frog with the stereopticon is desired.

NEWS AND NOTES.

Personals, news items, notices of meetings of societies, conventions, etc., will be received up to the twenty-second of the month preceding issue.



DAVID SIMONS KELLICOTT.

Journal of Applied Microscopy.

VOLUME I.

MAY, 1898.

NUMBER 5

David Simons Kellicott.

DAVID SIMONS KELLICOTT, born at Hastings Centre, New York, January 22, 1842, died at Columbus, Ohio, April 13, 1898. Professor Kellicott died on the above date after an illness of ten days with pneumonia.

He graduated from Syracuse University, then Genesee College, with the degree of B. Sc., in 1869, and took the D. Ph. degree here in 1882. His college career was interrupted on occasions when he taught at Scioto Furnace, Ohio, and at Mexico Academy, New York. He was teacher of science in the Keystone State Normal School from 1870 to 1872, and teacher of natural sciences in the Buffalo State Normal School from 1872 to 1888. In 1888 he was appointed professor of zoölogy and entomology at the Ohio State University, and held this position until the time of his death.

As a man he was modest, yet strong, honest in all his undertakings. The universal esteem and respect of his large circle of friends testify to his character. As a teacher, he was painstaking, of inexhaustible patience, and with a personal interest in each one of his students. He holds not only their admiration, but also their love. His colleagues in the faculty evidenced their estimate of him by their helpful sympathy and keen interest during his illness.

As a scientific worker, the numerous contributions he made through journals and scientific societies, speak of his untiring energy and attainments. He was a keen and accurate observer, all of his work marked by a characteristic honesty, and his communications were never biased by personalities. He was elected president of the American Microscopical Society in 1888 and again for the current year. He was now serving his term as general secretary of the American Association for the Advancement of Science. In the Ohio Academy of Science he had served as treasurer and as president. In local scientific societies he was prominent and, as always, an interested worker. His family, his university, his societies, will always feel the void made by his absence.

A. M. BLEILE.

COLUMBUS, OHIO, April 18, 1898.

The Demonstration of Karyokinesis.

By B. F. KINGSBURY.

Recent inquiries, one of them from an American medical college, seeking information as to methods of demonstrating the indirect division of cells, or karyokinesis, suggest that there may be others to whom as teachers or private workers a few hints as to material and methods will be helpful. Indeed, the writer's personal experience permits him to appreciate the help that may be afforded by such suggestions as are here intended. There certainly appears to be a lack of any specific suggestions or directions, those being most satisfactory that are contained in Whitman's* *Methods of Microscopical Anatomy* and Von Kahliden's† *Pathological Histology*, in neither of which is there suitable information as to material.

Nothing original is offered save perhaps a few observations on favorable forms for American workers, the intention being simply to present clearly a few standard methods in use here and elsewhere by means of which preparations may be obtained that will fulfill most of the desiderata in the demonstration of karyokinesis, i. e., the occurrence of all the stages in the same preparation, showing well the chromatic and achromatic figures in cells of a size well suited for class demonstration.

Since Schneider, in 1873, first established the occurrence in cell division of the intricate phenomena constituting what is variously termed karyokinesis, mitosis, or indirect cell (nuclear) division, we have had demonstration of it in all groups of animals, from the protozoa to man, and in plants from the algae to the higher phanerogams, and the earlier conceived direct division of cells has been found to be of rarer occurrence. For demonstration, however, attention was soon confined to narrower limits and a choice is given of Amphibia and the eggs of *Ascaris megaloccephala*, the parasitic round worm of the horse, and of the Echinodermata (sea-urchins, etc.) Among plants, the young embryo-sack of *Fritillaria* and the developing pollen cells of the members of the Liliaceae appear to have been favorite objects for demonstration. It is interesting to observe how closely anatomies published after 1885 confine themselves to these three groups for illustration of cell-division, with other forms, of course, occasionally supplementing or supplanting.

The Amphibia are by far the favorites, both because of the large size of the cells, their availability, and the pioneer work done upon them by Flemming‡ and Rabl,|| whose figures are often copied. Both the larval and adult animals may be used. Karyokinesis, however, is best shown in special localities; in the adult the testis, corneal epithelium, and epithelium of the tongue; in the larva the epidermis, oral and branchial epithelium. The epithelium of the lung and peritoneal cavity have also been employed. It is to be noted that the forms on which work has been done, and to which references in the literature apply, are almost exclusively European, Salamandra and Triton, and some may not realize the availability in America of forms fully as serviceable as either of these.

Of the organs above mentioned, the testis seems on some accounts most to be preferred, the only objection being that the results are dependent on the breeding habits of the animal and therefore on the time of year. Salamandra, the European form so much worked on, mates early in the spring, and, as Flemming** first made known, spermatogenesis occurs as a yearly cycle beginning with the breeding season. After the deposition of the spermatozoa, there is a general increase in the size of the testis during the spring months, caused by a multiplication of the residual cells (spermatogonia). This is most vigorous during the late spring and early summer, May to July. In July and the first part of August the final divisions take place and the maturation of the zoöspersms begins, extending well into the fall. The winter is spent with the testis in a resting state, charged with ripe spermatozoa. Thus, in order to obtain karyokinesis, it is necessary to use animals taken during the late spring or early summer.

In America, we are favored with a larger number of forms with a greater range of habits, allowing us to be somewhat more independent of the time of year. *Diemyctylus (viridescens)*, represented on the Pacific slope by *torosus*, the vermilion-spotted newt, in its range and the ease with which it may be obtained from ponds and ditches in the eastern United States, is perhaps most available of our forms; it is, however, quite nearly related to the European salamanders and resembles them closely in its mating habits and spermatogenesis, making it available for the demonstration of cell-division only dur-

*Whitman, C. O. *Methods of Research in Microscopical Anatomy and Embryology*. Boston, 1885.

†Kahliden, C.von. *Methods of Pathological Histology*. Translated by H. M. Fletcher. London, 1894.

‡Flemming, W.; *Zellsubstanz, Kern und Zelltheilung*. Leipzig, 1882.

||Rabl, C.; *Ueber Zelltheilung*. *Morph. Jahrbuch*, Vol. X, 1884-85.; pp. 214-330.

**Flemming, W.; *Neue Beiträge zur Kenntniss der Zelle*. *Arch. f. mikr. Anat.*, Vol. XXXIX, 1887, p. 389.

ing the late spring and summer months. Karyokinesis may be found well into August, though not abundantly. The males are easily distinguished by the greater size of the hind legs and the broad caudal fin-fold. The portion of the testis containing cells is a translucent gray, while that in which the lobules are filled with ripe spermatozoa is an opaque white or yellow-white, as Fleming pointed out in *Salamandra*, there being in neither form pigment to obscure the effect.

Amblystoma (*punctatum* in the East, *tigrinum* in the central portions) also mates in the early spring (March or April), and presumably in the stages of spermatogenesis it corresponds in general to *Diemyctylus*. Cell-multiplication is still going on in early August, however. *Amblystoma* is not as easily obtained as *Diemyctylus*, secluding itself under logs and stones except at the breeding season, when it is valueless for karyokinetic purposes.

Necturus (the mud-puppy or water-dog of the vernacular) presumably must likewise be taken in the early summer, since individuals taken from early fall to late winter show the testis filled with ripe spermatozoa. It has been difficult to obtain it here during late spring or early summer.

In addition to these salamanders, which are available, and contrasting with them, we have as occupants of the brooks in the eastern United States, two other genera of salamanders, *Desmognathus*, the dusky salamander, and *Spelerpes*. Little is known of the breeding habits of these genera, but all evidence that we have points to the fact that the breeding season, instead of coming in early spring, comes in late summer or even late in the fall, eggs having been found in October.†† At all events, lobules in stages of karyokinesis are found in specimens taken in early fall to mid-winter, and probably, in the case of *Desmognathus* at least, up to April. In both of these the testis are densely pigmented and the regions of cells and spermatozoa cannot be as easily distinguished as in *Salamandra* or *Diemyctylus*. Spermatogenesis, however, seems to proceed from the cephalic toward the caudal end, causing an enlargement of the testis and a diminution of the amount of pigment, and it is in the narrower region, or where the larger and smaller portions meet, that cell-division is generally found. In *Desmognathus*, there are sometimes (not always) found two, rarely three, divisions of the testis, corresponding ap-

parently to two centers of spermatozoa formation.

Testes of *Diemyctylus* and *Amblystoma*, then, are suitable for karyokinesis during spring and early summer (May, June, July); *Desmognathus* and *Spelerpes*, on the other hand, may be employed during fall and winter. Doubtless other genera belonging to the same families will likewise be found equally serviceable at the same seasons.

The fixing fluids that experience has shown to be most suitable are: Hermann's platino-aceto-osmic, (Formula: Platinum bichlorid ten per cent. aq. sol. three parts, one per cent. osmic acid sol. sixteen parts, glacial acetic acid two parts, water nineteen parts; or, take platinum bichloride one per cent. sol. fifteen parts, two per cent. osmic acid four parts, glacial acetic acid one part); Flemming's chromo-aceto-osmic mixture (strong formula) is the same as Hermann's, save that chromic acid is substituted for the platinum bichloride), and also picric acid. The method of their use is as follows: It will be found best to cut the testis through the middle of the enlarged portion. Place both pieces for twenty-four hours in an abundance (15-20 cc. per testis) of either Hermann's or Flemming's fluid; wash in running water six hours or over night, and harden in alcohols of fifty, seventy, and eighty-two per cent. strengths. The superficial layers of cells will be found to be over-fixed and detail partly or entirely lost; deeper cells will, however, be satisfactory. A thorough washing out of the fixer is important, that there be no subsequent blackening of or precipitate in the tissue. Sometimes, nevertheless, a precipitate occurs which may be removed by bleaching for a few minutes before staining, with a mixture of one cc. of hydrogen dioxide solution in ten or twenty cc. of seventy per cent. alcohol. Paraffine should be employed for imbedding; the sections should be between five and ten μ th in thickness and be made longitudinally of the testis. For staining, most serviceable will be found Heidenhain's Iron Hematoxylin with or without after-staining in orange G, or safranin with or without light green as a counter-stain. For the iron hematoxylin (a) mordant for one hour in a four per cent. aq. sol. of ferric alum (iron-ammonium-persulphate), rinse well in water one or two minutes, (b) stain one to three hours or until black in a four-tenths per cent. aq. hematoxylin (may be conveniently made up by taking three cc. of a sixteen per cent. alcoholic stock solution of hematoxylin in one hundred cc. of water.) Any aqueous hematoxylin may be taken, however, the time of staining being longer for weak formulas.

††Sherwood, W. L. The Salamanders found in the vicinity of New York City, with notes on extra-limital or allied species. Proc. Linnaean Soc. of N. Y., No. 7, 1895; pp. 21-37.

(c) Rinse in water and differentiate by dipping into the ferric-alum solution for a few seconds and then rinsing in tap water, repeating the operation until the right degree of differentiation is attained as determined by examination under the microscope. The chromatin should be stained a blue-black or black, the spindle gray or light blue. Wash well in water for about twenty minutes and dehydrate, clear and mount in balsam, or, if it is preferred, stain after washing for a minute or so in a strong one-half saturated aqueous solution of orange G.

One of the best safranin stains to employ is Babes'—equal parts of concentrated aqueous and alcoholic solutions. Stain in this three to twenty-four hours, wash with ninety-five per cent. alcohol, clear, and mount in balsam. No other differentiation than that of the ninety-five per cent. alcohol is needed with this formula.

Picro-acetic mixture, of which there are several formulas, is possibly even better than the two standard fixers just mentioned. It is a saturated aqueous solution of picric acid, or (possibly better) a half saturated solution (saturated solution one part, water one part) of picric acid with one or two per cent. of glacial acetic acid added. Place the testis in this for six to twelve hours, soak in seventy per cent. alcohol one day and in eighty-two per cent. alcohol several days, changing until the picric acid is almost entirely removed, when it may be carried on for imbedding. The most satisfactory stain with tissue fixed in this way is Heidenhain's iron hematoxylin, as above. The time of mordanting and staining may be much shorter than with Hermann's or Flemming's; one-half hour in the ferric alum, and half an hour in the stain. Safranin is not as satisfactory with this fixer as with Flemming's or Hermann's. Any one of these fixers and stains gives good figures of cell-division, suitable for demonstration.

The testis of the crayfish, so common in our rivers and streams, likewise is a very good subject for the demonstration of karyokinesis, the only objections being the small size of the cells and the large number of chromosomes. Their division, however, is very easily demonstrated, as is also the centrosome. The testis will be found immediately beneath the heart, on the dorsal side, under the carapace, and is easily distinguished as a three-lobed white organ. It may be removed from a five to eight cm. male in the summer or fall and fixed and stained in one of the ways mentioned above. The sections should not be more than five or seven μ thick.

The larvae of Amphibia, especially the tailed forms, are very suitable objects

for the demonstration of cell-division. Just hatched specimens are most suitable, although rapidly growing forms, such as *Amblystoma*, should be suitable throughout the spring. While division figures may be found readily in all parts of the body, the epidermis and oral epithelium are the most favorable regions. By fixing but a short time (one to two minutes) it is possible to remove large pieces of the epidermis by scraping, and these may be washed, examined, stained if found suitable, and mounted without further treatment. It will be found more satisfactory, however, to fix the caudal portion in one-third per cent. platinum chloride or chromo-formic (four or five drops of strong formic acid in two hundred cc. of a one-third per cent. aq. solution of chromic acid, added just before using). Leave in either of these twenty-four hours, wash in water four to six hours, and harden in fifty, seventy, and eighty-two per cent. alcohols. Sections parallel to the surface should be made so as to cut the epidermis very obliquely and have more cells in each section. *Amblystoma* is most favorable, since the young larvae are not densely pigmented and grow very rapidly. *Spelerpes* larvae, although they may be found during summer and winter, are not serviceable, apparently because of their slow growth.

The Amphibia have one disadvantage, in that the achromatic portion of the figure is not as strongly developed as is desirable; the testis seems the least objectionable from this aspect. On the other hand, in invertebrate eggs generally, and especially *Ascaris* and *Echinoderm* eggs as most available, the spindle and polar radiations are strongly developed. These forms are not as generally available as are the Amphibia. Those who are so located that they have access to freshly killed horses may obtain from the coecum or ileum, the parasitic worm, *Ascaris megaloccephala*, from which the uterus filled with developing eggs may be removed and fixed in either of the three following fluids: (a) Glacial acetic acid one part, absolute or ninety-five per cent. alcohol three parts; (b) absolute alcohol one part, glacial acetic acid one part, chloroform one part, and mercuric chloride to saturation; or (c) seventy per cent. alcohol eight parts, glacial acetic acid two parts, which formula Professor Conklin of the University of Pennsylvania has stated to be very satisfactory. In formula (a), wash out with strong alcohol until all odor of acetic acid has disappeared; in formula (b), wash thoroughly in fifty per cent. alcohol until all trace of the acid has been removed, and in seventy and eighty-two per cent. alcohols changing

until the mercuric chloride has been all washed out; in formula (c) wash one day in seventy per cent. alcohol and store in eighty-two per cent. alcohol.

Mammals from which demonstrations of karyokinesis are most to be desired, especially for medical students, are, nevertheless, the most unsatisfactory. The testis again, especially of rodents such as the mouse, rat, or guinea-pig, is perhaps most favorable. It should be cut up into small pieces and fixed in Flemming's or Hermann's twenty-four hours, washed in running water several hours, and hardened in the alcohols. Iron Hematoxylin or safranin will again be found the most satisfactory stain. The mesentery of new-born rabbits has been recommended as affording satisfactory demonstrations of cell-division in the covering epithelium.

Likewise the amnion of the rat has been advanced ||| as a good tissue for demonstrating indirect cell-division. White rats were employed and the amnion of embryos, eighteen to twenty mm., were fixed in strong aqueous solution of picric acid (picro-acetic will do) or Flemming's fluid, spread out flat on the slide, and stained with hematoxylin. The karyokinetic figures are represented as being numerous and large. Neither of these methods have been personally tested; it is suggested that other new-born animals, e. g., kittens and the amnion of other embryos, may be used with equally good results.

Cornell University.

††Orth, Joh.; *Cursus der normalen Histologie zur Einführung in den Gebrauch des Mikroskopes sowie in das praktische Studium der Gewebelehre*. 5te Aufl. Berlin, 1888.

|||Solger, B. *Saugethier-Mitosen im histologischen Kursus*. Arch. f. mikr. Anat., Vol. XXXIII, 1889, p. 517.

The Use of Formalin in the Silver Nitrate Method of Staining Endothelial Cells.

G. CARL HUBER, M. D.

The following method has proven very satisfactory in preparing preparations, to show the endothelial cells of vessels and serous membranes, for large classes.

A small mammal (rat, Guinea-pig, small rabbit or cat) is narcotized. Before the heart's action is completely arrested, the thorax is opened and the heart incised. As soon as the blood stops flowing, a canula is inserted and tied in the thoracic aorta a short distance above the diaphragm, and fifty to eighty cubic centimeters of a one per cent. solution of silver nitrate injected through the canula. About fifteen minutes after the

injection of the silver nitrate solution, there is injected through the same canula one hundred to one hundred and fifty cubic centimeters of a four per cent. solution of formalin (formalin ten parts, distilled water ninety parts), the inferior vena cava being cut, just before it enters the heart, before the injection of the formalin. The abdominal cavity is then opened, loops of the intestine with the attached mesentery removed, and placed in a four per cent. solution of formalin, in which the tissue is exposed to the sunlight. As soon as the reduction of the silver nitrate has taken place, which is of course easily recognized by the brown color assumed by the tissues, the mesentery is divided into small pieces, dehydrated first in ninety-five per cent. then in absolute alcohol, cleared in oil of bergamot, and mounted in balsam. As a rule the endothelial cells covering the two surfaces of the mesentery, and the endothelial cells lining the arteries, veins, and capillaries are clearly outlined by the reduced silver nitrate. It often happens that the intercellular cement between the non-striped muscle cells of the vessels is also stained, giving thus clear outlines of the involuntary muscle cells.

If desired, the tissue may be further stained in haematoxylin (we have used Boehmer's haematoxylin solution) after dehydration in ninety-five per cent. alcohol; after which they are dehydrated, cleared, and mounted in balsam. It has seemed to me that by washing out with formalin what silver nitrate there remains in the vessels, after the formation of the albuminate of silver with the intercellular cement substance, the brownish precipitate which is so often found in the vessels after the reduction of the silver, when the silver nitrate method is employed as usually recommended, is done away with. The injection of formalin into the vessels tends also to harden them in a state of distention, which is an advantage.

University of Michigan, Ann Arbor, Mich., February, 1898.

The Microscope on a Man-o'-War.

The compound microscope is admitted to be an aid to our senses. The formation of a diagnosis is the result of judgment founded on observation of the case. Any agent that may extend the means of observation or render such more accurate is an agent of great gain. On this ground we claim that the microscope is of great importance where sick are cared for, on board our men-of-war as well as in hospitals and private practice. It is of as much value as the

stethoscope, the clinical thermometer, the probe, etc. It is now maintaining the highest rank among instruments of research.

The microscope is of great value on board the ships of our navy. The "flag-ship," the ship that the admiral or commander-in-chief of a fleet or station is attached to, is furnished with a microscope as part of the equipment for the medical department of that ship. The other ships, as a rule, are not furnished with any, but can easily obtain them by the senior medical officer applying for them to the department. Reports of investigations and research must be made and specimens sent to the department from time to time.

The department issues microscopes with 1_n, ½_n, and 1-12_n objectives and a fine list of accessories, especially made for the bureau. By means of these the acts of sharks ("land sharks") and impurities and adulterations can be easily discovered, which would otherwise remain unobserved.

The following are some of the more common: starch of various kinds, improperly added to cocoa and mustard; willow is sometimes substituted for tea; chickory is found mixed with almost all coffees. Chickory, if not added in too large quantities, rather improves than injures the aroma or flavor of coffee.

The more important uses of the microscope on board ship are as follows: Milk is of such a nature at some ports that the examination of it may save the outbreak of an epidemic, such as typhoid fever. This fever was brought on board one of our battleships recently, and its only source was from milk obtained ashore where disease existed.

The Examination of Sputum.—Some difficulty is experienced in this examination, as sputum is liable to contain many particles which did not come from the lungs, such as fragments of food, scales from the tongue and mouth. The degree of catarrh can be easily determined in this way, as during the progress of the disease the inflammation of the mucus tract and the number of leucocytes becomes more and more abundant. When the lung is breaking down fragments of pulmonic tissue may be readily recognized under the microscope by the characteristic elastic fibers, which are rendered very distinct by the addition of acetic acid or previously boiling with a solution of caustic soda (20 grains to the ounce) which clears matter, leaving tissues untouched. Tuberculosis is also recognized by the presence of the tubercle bacilli.

Urine.—The examination of urine is made to a large extent by the microscope. It is important to know the age

of sample examined, as the changes are sometimes misleading. A portion of the urine passed in twenty-four hours should be taken, and especially that which is passed in the morning. Frequently an examination for several successive days is necessary, for there are conditions of kidney disease in which few casts are passed and would probably escape in one examination.

The microscope is much used in the examination of tumors, abscesses, gonorrhoeal discharge, and many forms of bacteria which I cannot mention here for want of time. In establishing the great truth which connects physiology and hence pathology with anatomy, and in maintaining and following this truth, the microscope ranks highest of our instruments of research.

WM. H. MYERS, PH. G.,

Apothecary, U. S. Navy.

U. S. S. S. Terror, April 8, 1898.

A Scheme for Counting Colonies of Bacteria in Petri Dishes when the Colonies are Small and Very Numerous.

I have for the past two years used the following method of estimating the number of bacteria per cubic centimeter in stomach fluid, in the Laboratory of Hygiene of the Battle Creek Sanitarium. Sometimes the bacteria number up into the hundreds of thousands and even millions per cubic centimeter, and the ordinary methods of counting are not applicable.

Making use of the principle that circles are to each other as the squares of their respective diameters, I proceed to find a microscopic field which bears a definite ratio to the size of my petri dishes. For instance, my petri dishes have an internal diameter of 90mm, and I find by means of a stage micrometer a field in the microscope which has 1.5, 1.8, 3.0, 3.6 or 4.5 mm. diameter. By means of the proper objective and ocular and by lengthening and shortening the draw tube, a field of the proper diameter can be obtained. Then a mark can be made on the draw tube for future use, or a memorandum can be made something in this manner: B. and L. Microscope No. 42756, objective ⅜ inch, ocular No. 1, draw-tube 163 mm.=2500 fields to a 90 mm. petri dish.

To ascertain the proper factor (or ratio existing between the microscopic field and the petri dish) use the formula $d \div d' = f$ in which d = diameter of petri dish; d' = diameter of microscopic field; f = factor. In my work I used a field

of 1.8 mm. with 90 mm. petri dishes, plated $\frac{1}{2}$ cc. of stomach fluid, and used 5000 as a factor. For greater accuracy I count ten fields and use 500 as a factor.

Where I expect the bacteria to number up into the millions per cc. I adopt the following method:

With an accurately graded sterile pipette, I transfer 1 cc. of the fluid under examination to a flask containing 100 cc. of sterile water. Shaking this thoroughly, I take with another sterile pipette one cc. of the dilution and transfer to a second flask containing 100 cc. of sterile water, then with a third, and possibly even a fourth flask, the process is repeated. The dilutions in the flasks will be respectively 1:100, 1:10,000, 1:1,000,000, 1:100,000,000. By making plate cultures from each of the flasks, one will be found when the colonies can be readily counted by ordinary methods and the proper factor used. This, it seems to me, is an improvement on the custom sometimes in vogue, of designating bacteria when found in these large numbers as "countless."

GEORGE H. HEALD, M. D.

Instructor in Bacteriology in the American Medical Missionary College, Chicago, Ill., and Director of the Battle Creek Sanitarium Laboratory of Hygiene.

A Note on the Mounting of Golgi Preparations.

G. CARL HUBER, M. D.

A number of years ago I pointed out that Golgi preparations might be mounted under a cover-glass if certain precautions were followed. My further experience with the method then proposed, and the fact that some of my preparations mounted some six years ago are still practically as good as when first made, prompts me in again calling attention to this method.

After the completion of the impregnation the blocks of tissue are placed in absolute alcohol twelve hours, equal parts of ether and absolute alcohol, twelve hours; and thin celloidin, twelve hours. They are then blocked on corks in the usual way. As soon as the celloidin is hard enough to cut, sections varying from 25 μ to 100 μ (according to the tissue to be studied), are cut into ninety-five per cent. alcohol. The sections are then transferred into absolute alcohol, in which they remain fifteen to twenty minutes. From the absolute alcohol the sections are placed in creosote, which completes the dehydration and clears the preparations. In this solution the sections are allowed

to remain about ten minutes, are then transferred to turpentine, where they should remain another ten minutes. From the latter solution the sections are removed to the slide. The excess of turpentine is now removed by pressing the sections to the slide with several filter papers. The sections are then to be covered with a relatively large quantity of balsam, and carefully heated over a flame, for two, three or four minutes* or until so much of the solvent of the balsam has been driven off by the heat, that the balsam will set as soon as it becomes cool. Before the balsam cools, the preparation is covered with a cover glass, which has been passed through the flame several times before placing it on the balsam. It seems to me that it is only necessary to dehydrate the sections thoroughly and then mount them in hard balsam to insure their keeping without deterioration when mounted under a cover-glass.

University of Michigan, Ann Arbor, Mich., February, 1898.

* Huber, Zur Technik der Gologischen Faerbung. Anatomischer Anzeiger, No. 18, Vol. VII. 1892.

Notes on Microscopical Technique.

G. CARL HUBER, M. D.

Third Paper.

SECTION CUTTING.

In the third article of this series, I purpose briefly to discuss the procedure of cutting microscopical sections. But at the outset, it may be well to state that it is as impossible to teach the uninitiated how to cut sections by verbal or written description as it is to teach a boy how to swim by verbal directions. Here, as in everything, "practice makes perfect."

Before beginning, however, the few hints which it seems to me might be useful to one beginning section cutting, a few words about the microtome and knife may not be amiss.

Microtome.—In selecting a microtome, which might serve as the basis of my remarks, I am guided by the following considerations: Cheapness, general applicability, ease of manipulation, and durability. These requisites are, I believe, best met by an instrument built after the Schantze pattern, an instrument, which, in the opinion of the writer, will serve every purpose which might be required of a microtome by a physician, and is shown in Fig. I. This instrument consists of a frame A, of a slide B, which supports a block C, which in turn supports D, the knife-holder. It is provided with a clamp E for holding the paraffin or celloidin blocks; this is

attached to a slide F, which may be elevated or lowered by a feed, G, which consists of a micrometer screw acting on the lower surface of the slide. The micrometer screw is provided with a milled head, divided into a definite number of parts which bear a definite relation to the pitch of the micrometer screw.

The instrument shown in the figure is further provided with a lever H, which may be so adjusted as to move the milled head on the micrometer screw one, or any desired number of notches at each movement of the lever; and as each notch on the milled head has a value of 5 microms (1-5000 of an inch), every time the milled head is moved one notch

filtered kerosene oil. While sharpening the knife it is grasped with both hands, with one by the handle, with the other by the end. The hone is placed on a table with one end directed toward the person sharpening. If the knife is very dull, it is ground for some time on the concave side only (all microtome knives are practically plane on one side and concave on the other), with the knife at right angles to the stone. It is carried from one end of the stone to the other, edge foremost, giving it at the same time a diagonal movement, so that with each sweep the entire edge is touched (see Fig. 2). In drawing back the knife, the edge is slightly raised. The knife is ground on the concave side

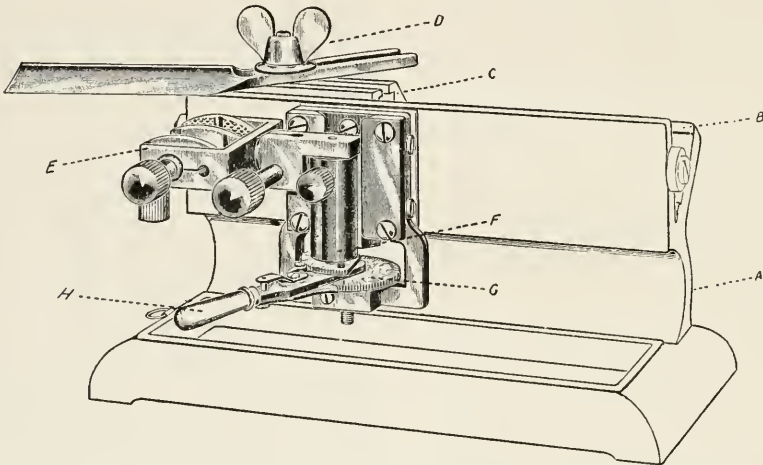

Fig. 1.

(toward the manipulator), the slide carrying the clamp holding the tissue is elevated 5 microms; two notches would elevate the tissue 10 microms (1-2500 of an inch); four notches, 20 microms (1-1250 of an inch), etc. It is not essential to have a lever, as above described, attached to the instrument, although this is very convenient, in which case the milled head is moved the desired number of notches with the hand.

Microtome Knife.—No matter how well the tissues may be hardened and imbedded, and no matter how good the microtome may be, unless one has a good and sharp microtome knife, good sections cannot be cut. To be able to sharpen a microtome knife is therefore very essential unless one wishes to send the knife to an instrument maker every little while. For this purpose I use a Belgian hone and moisten or lubricate the same, while grinding the knife, with

until a fine thread (feather edge) appears along the entire edge. It is then ground on both sides, care being taken to keep the knife at right angles to the stone, to keep it flat on the stone and to use practically no pressure at all. It is a good plan to turn the knife, when the end of the stone is reached, on its back. On the return stroke, the knife is again held at right angles to the stone, the same diagonal sweep is used (see Fig. 2), so that the whole edge of the knife is touched with each sweep of the knife. The grinding on both sides is continued until the thread above mentioned has disappeared. The knife should now be carefully cleaned and stropped, with the back of the knife toward the strop. The strop should be flat and rest on a firm surface. After stropping, the knife should cut a hair held between the fingers, but the best test for the knife is, after all, that of cutting sections.

THE CUTTING OF PARAFFIN SECTIONS.

The Position of the Knife.—I usually place the knife at an angle of about 30° to 35° to the microtome. I believe sections are cut more easily with the knife in this position, than when the knife is placed at right angles to the microtome, as is often recommended, and it does not seem to me that the tissues suffer materially from distortion, when they are cut with the knife at an angle, as is sometimes claimed.

Section Cutting.—In the last article of this series the method of imbedding sections in paraffin was described, and

clamped in the microtome. This is done in such a way that the paraffin block just escapes the knife when drawn beneath it. A number of rather thick sections (20 to 40 microms) are cut by moving the micrometer screw from right to left four to eight notches every time the knife has been drawn over the paraffin block and has been brought back again, until it is noticed that the knife touches all parts of top of the paraffin block, or until the tissue is fairly exposed. The sections may now be saved, and it may perhaps be well to state that it is better not to try and cut very thin sections to begin with;

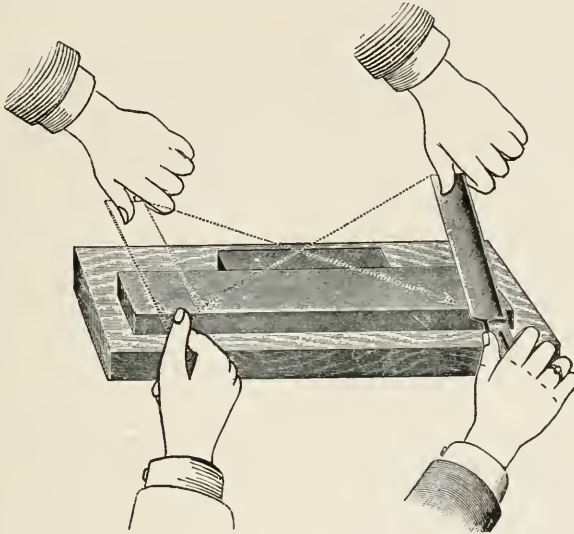

Fig. 2.

it may be remembered that after thorough impregnation of the tissues with the paraffin had been discussed, directions were given for blocking the tissues in paraffin by means of the imbedding L's. Before fastening the paraffin blocks into the clamp on the microtome, preparatory to cutting sections, the paraffin is trimmed with a sharp knife from the end of the paraffin block, until the tissue is exposed, care being taken, however, to leave a flat surface. The top of the paraffin block is then beveled off on three sides to within a very short distance of the tissue. The fourth side, that which faces the knife when the block is clamped in the microtome, should be trimmed only to within about one-eighth of an inch of the tissue. This edge of paraffin is made use of, as will be seen in a moment, for preventing the sections from curling while they are cut. The paraffin block is now ready to be

sections twenty to fifteen microms in thickness will answer very well. To begin with then, the milled head of the micrometer screw is turned four notches from left to right, then the knife is drawn over the block with a steady, even pull and without using undue pressure. Usually the sections will curl up as they are being severed from the paraffin block. This may very readily be prevented by holding the tip of a camel's hair brush, which has been pointed by drawing it between the lips, against the edge of the section, as soon as it begins to curl. A little practice will enable one to do this almost automatically. The sections are transferred to a paper by means of the camel's-hair brush, which process is facilitated if the brush has been slightly moistened with saliva, as the section will then adhere lightly to the brush.

The Cutting of Paraffin Sections in Ribbons.—If the tissues are well imbedded and not too hard, and if the knife is sharp and properly adjusted, paraffin sections may be cut in such a way that each succeeding section adheres to the preceding one, so that actual ribbons of paraffin sections may be made. In order to do this, the knife should be at right angles to the microtome. The paraffin block should be trimmed in such a way that when clamped in the microtome ready for cutting sections, the surface of the paraffin block facing the knife should be exactly parallel to its edge, also the opposite side of the block. In other words, two sides of the paraffin block should be parallel to each other and to the knife, then if the paraffin is of the right consistency, which must be ascertained by trying, the sections as they are cut will adhere to each other and form a ribbon. If the sections do not adhere to each other, it is quite probable that the paraffin is a little too hard. This may often be remedied by holding an old knife or other metallic instrument which has been heated in a flame, near the two parallel surfaces. Care should be taken not to allow this instrument to touch the paraffin. This is a very convenient and rapid way of cutting paraffin sections.

The Cutting of Celloidin Sections.—For cutting sections of tissues embedded in celloidin, it is necessary to clamp the knife at an angle of about 30° to the microtome. In a former article I have explained the fixing of the celloidin block to a small wooden block. Before fastening the block in the clamp on the microtome, the celloidin should be trimmed with a sharp knife from the top of the block until the tissue is exposed, care being taken to leave a flat surface. The sides of the celloidin block are then trimmed down, if necessary, to within about one-sixteenth of an inch of the tissue. The block is now clamped in the microtome, at such a level that it just escapes the knife when drawn over it. During the process of cutting, the knife, as also the tissue, must be kept constantly moistened with 80% alcohol. This is perhaps most easily accomplished by taking up the 80% alcohol with a rather large camel's-hair brush and dipping this on the celloidin block and on the knife.

A number of rather thick sections are cut, until the knife touches the entire surface of the block or until the tissue is well exposed. The sections may now be saved. The block is raised twenty to fifteen microns, four to three turns of the milled head from left to right, and the knife, which should be well

moistened with 80% alcohol, is drawn over the block with a steady pull, not with a jerk. The sections are transferred from the knife to distilled water. This is perhaps most conveniently done by placing the ball of one of the fingers of the left hand under the edge of the knife, in front of the section, and drawing the section down on to the finger with the camel's-hair brush. The finger is then dipped into the distilled water, when the section floats off. If the sections cannot be stained within a few hours after they are cut, they are best transferred to a dish containing 80% alcohol, in which they may be left until it is desired to stain them.

(To be Continued.)

An Improved Form of Paraffin Embedding Table.

In previous numbers of the Journal several persons have noted and commended a simple form of paraffin embedding table. Such a table is useful in many ways besides in embedding, and is certainly the simplest as well as in some respects the most satisfactory constant-temperature apparatus for all laboratories where gas is not accessible. It is my purpose to call attention here to a slightly modified form which has proved itself superior to the older type in several respects. The general form which is represented in the figure may be described as that of a goose-neck table; it has reached the form at present in use in this laboratory by minor changes at the hands of a number of persons, so that I can claim no peculiar originality in its construction.

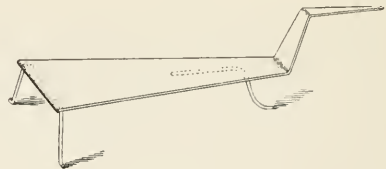

The table is made of a triangle of sheet copper with a base of six inches and perpendicular height of fourteen inches. The edges of the triangle are turned under and inward, giving to the table a smoothly rounded margin. In height the main part of the table measures two inches, and it is about four inches high under the apex of the triangle, where is placed the heating flame, which may be gas or an oil or alcohol lamp; with any of these, provided the position of the table is sheltered from sudden changes due to draughts, a uniform temperature

may be preserved through long periods of time. The legs are made of five-sixteenths copper rod bent as shown by the dotted line and riveted to the copper sheet.

The advantages claimed for this construction over the ordinary form are: (1) its rigidity, due to the folded margin of the table and the strength of the leg bars underneath; (2) its greater stability, since it cannot be overturned by anything less than a very violent motion, whereas the ordinary form, such as depicted on page 63 or 71 of this journal, is decidedly unstable; (3) the diminished liability to accident in transferring from table to stand owing to the lessened height; (4) the easier manipulation of objects in dishes or trays upon it, since the elbows of the student may be rested on the laboratory table, and his arms need not be raised so high to reach the dish. And, finally, in my opinion, at least, the form described here is both neater and more graceful in appearance.

HENRY BALDWIN WARD.

The University of Nebraska, Lincoln,
April 23, 1898.

DISCUSSION.

Papers upon live subjects within the province of the JOURNAL will be printed over the author's signature.

Educational Value of Microscopical Work.

E. W. CLAYPOLE.

Apart altogether from the knowledge gained through the microscope and the value of this knowledge in future and professional life, there are advantages which are seldom realized before and which are often forgotten after going through a course of microscopical work. I refer to the unconscious training of the senses and the fingers that results from the work itself, independent of any ultimate purpose. The actual knowledge is chiefly of value to the professional worker in one or other of the many fields in which this instrument is now important or necessary. But the other benefit is common to both the professional man and to those by whom no special use is made of the microscope in later life, and this is my reason for claiming in behalf of this study an important place in general education. Teachers are gradually awakening to the fact that they have gone on too long in the old way of cultivating the memory to the comparative neglect of the other powers. The truth has been forced home upon them that the education which they were giving

was not an education that fitted the young, as they should be fitted, for the work of life. Good as far as it went, it failed to develop the faculties evenly or generally. There has consequently arisen much dissatisfaction with existing methods, and in response we see the introduction of the kindergarten, the manual training, and the laboratory course. Of the first and second I cannot here write save to say that they are most important agents in the work of educational reform, and if carried out in spirit and not allowed to subside into mere routine, will ere long work important and valuable improvements. But the third of the three great innovations in the old system of education, and that perhaps which has met with the most opposition and has been attended with the greatest success, the laboratory method, is the one to which here I wish to refer, only, however, to one part of the subject, that in which the microscope is the instrument employed. Other parts are of not less value, but do not lie within the scope of this note.

I do not allude to the value of the instrument as a means of fitting a man to gain a living in one of those professions in which it is now indispensable. This, as already admitted, is of vast importance, but must be excluded for the present. I desire only to emphasize the value of microscopic work in general education to those who never intend to lead a professional life. Altogether, aside from its monetary aspect, the work itself is followed by certain manifest and inseparable advantages. In the first place, the neatness and care which must be constantly present if good results are to be attained, grow gradually into habits. Attention to minute details, everywhere desirable, here becomes necessary. The eye grows critical and refuses to be satisfied with careless and unclean work. This reacts on the mind and is in itself an education of priceless value. Methods often surpass results in practical life. It is not too much to say that in a well-managed laboratory the moral training superinduced by the very nature and quality of the work is an element of the first importance. This is said without prejudice to the results of study along other lines.

Again, the education of the hand is second only to that of the brain and eye. The clumsiness of many students at the outset of a course in the microscopical laboratory is one of the most trying and vexatious impediments in the way of their progress. Neglect of early training is largely responsible for this difficulty. Evils and defects that should

be cured in childhood are allowed to become deeply inwrought. Their eradication is then tedious and at best but incomplete, while the task is trying to the patience and to the temper of both teacher and pupil. The latter, in blank unconsciousness of his defects, thinks that he is doing his best, and this is probably true. The former is bitterly lamenting the necessity of expending time and effort in doing what should have been done earlier, at school, or, better still, at home. That a scalpel is not the proper tool for sharpening a pencil; that objectives must on no account be dropped; that stains and other reagents should not be poured out like water; that section razors must be carefully handled and dried; that material must be kept in good condition; that stoppers should not be laid down on the table; that pages should never be turned over and soiled by the wetted fingers; that the hand should contain eight fingers and two thumbs rather than ten thumbs,—all these facts are so elementary, that common sense and early training should have impressed them on the mind before the student reaches the actual laboratory. Yet every teacher in this department finds numbers of young men and some, though fewer, young women to whom it is all new and strange, and to whom it must be taught at the outset of their laboratory studies. Let us hope that the extension of the kindergarten and the manual training school will gradually eliminate these troublesome factors from the educational problems.

Thirdly, a student with the microscope cannot fail to become deeply convinced of the importance of little things, of the "next to nothing." The minuteness of the material, the magnification of the faults, the need of exact adjustment, the absolute necessity for delicacy of touch to avoid failure, are very powerful agents in this process of education. The ten thumbs of the average beginner, which are everywhere but in the right place, and which are so cleverly mischievous in overthrowing bottles, wasting material, losing time, and trying temper, are gradually transformed into the eight fingers and two thumbs of the careful and experienced manipulator which are always just where they should be. This again is in itself an education of the highest value in life. It amounts to scarcely less than the development of a new sense. It is the difference between the hands of the conjurer and the clown.

Without unduly lengthening this note, I cannot touch on some other indirect advantages of this study, but must dwell for a moment on one more and perhaps

the most important of all. The young microscopist is ever ready to jump to conclusions. He sees because he thinks he sees. He is far more confident than his teacher. He knows not so well the pitfalls and traps that nature lays in his way. The art of interpreting what the microscope reveals is of the foremost importance. Not the obvious, but the recondite, is usually the true. To ascertain exactly what the slide really exhibits by repeated and tedious experiment and careful drawing, until every source of error has been eliminated and every objection anticipated, is a task usually beyond the conception of the beginner. And when by repeated failures and deception he arrives slowly at the comprehension of the fact that not what he thinks, but what is, is the object of his labor, and that no pains or time must be spared to insure the latter and escape the former, he has gained for himself an education for the work of life, surpassing any other that his studies can impart, for he has gained the deep and lasting conviction that truth is the object of all scientific research, and should be the object of all research, and he has further gained the almost equally valuable power of suspending his judgment until all the data are in hand, a condition of mind most hateful to the mass of mankind, who vastly prefer the positive dogma of ignorance to the guarded opinion of knowledge and experience.

The upshot of the foregoing somewhat disconnected remarks is therefore, that microscopical study has a more general bearing on education than is usually supposed, and that students who do not expect to use the instrument in later life would yet derive very great profit from going through a course of microscopical work for the sake of the indirect benefits which they would derive from it, benefits which cannot altogether be obtained in any other line.

Mesilla, N. M., Jan. 21, 1898.

The Journal has received numerous United States and Agricultural Experiment Station reports, books, and papers from authors, which will be formally acknowledged in due course.

These books and papers are placed in the library of the Journal of Applied Microscopy, and we would add in this connection, that any books or papers bearing on microscopical subjects will be gladly acknowledged for the library, and new books and papers will be carefully reviewed by competent authorities in the subjects treated on.

APPARATUS.

A New Thermo-Regulator.

The Reichert's Thermo-regulator, as commonly made, is far from being satisfactory. The small opening which allows a minimum flow of gas sufficient to keep the light burning is, as a rule, entirely too large, consequently, for cer-

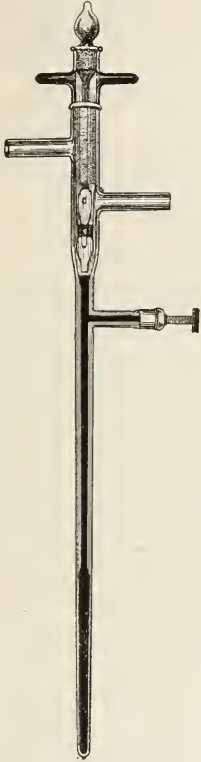

Fig. 1.

tain purposes, the minimum flame of such a regulator is still too large and gives, therefore, more heat than is necessary. This objection is recognized by many makers of instruments, and several modifications have been devised to permit regulation of the minimum supply. Some of these modifications are unquestionably a distinct improvement more or less, and thus will alter the minimum supply of gas. The slender inflow tube is very liable to break in making connections or otherwise. It is well known, moreover, that the average thermo-regulator cannot be used for upon the ordinary form. In some of these types, unfortunately, the weight of the rubber tubing attached to the inflow tube will cause this to move,

high temperatures (150°C.) as well as for low temperatures (30°C.). It is necessary to have two regulators, one for high and the other for low temperatures.

The thermo-regulator which I have had constructed, can be used for high as well as low temperatures. This is due to the large inflow and outflow tubes, so that a minimum resistance is offered to the flow of gas. Moreover, as will be understood from the description, the maximum inflow of gas can be regulated by turning more or less the part marked B in Fig. 2. The minimum outflow of gas in like manner is regulated by turning the part marked C. It will be observed, furthermore, that the rubber tubing is attached to strong lateral tubes which are independent of the regulating portion proper.

Fig. 1 shows the thermo-regulator as a whole, reduced in size.

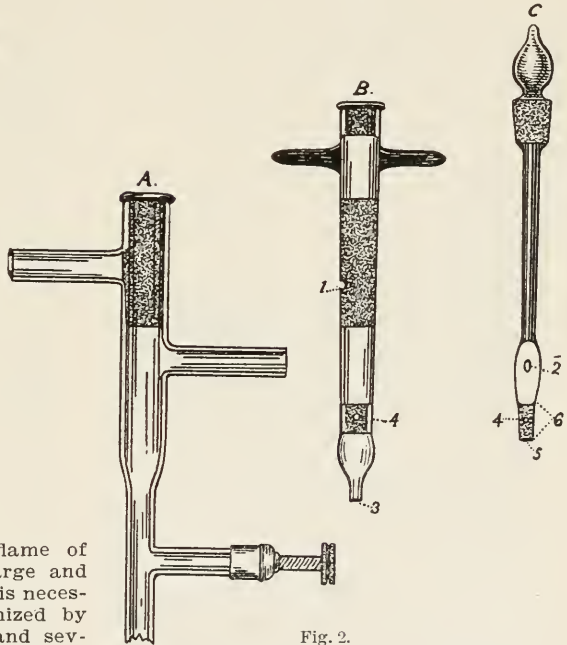

Fig. 2.

Fig. 2 illustrates the construction of the regulator. Part A is provided with the two lateral tubes which have an internal diameter of 6 mm., and has a ground internal surface indicated by the stippled portion of the drawing.

Part B is ground to fit the preceding. It is provided with an opening (1) through which the gas passes into the interior. The lower portion of B, opposite the outflow tube, is ground on the inside and has a small opening 1 mm. in diameter (4). The neck above is like-

wise ground internally. The lower portion of tube B has an internal diameter of 2 mm., and when placed in position, inside of part A, it should come within one or two millimeters of the bottom of the cup. In this case, the first droplet of mercury, as it issues from below, shuts off the outflow of gas. This is an important condition, and should be carefully seen to in the manufacture of a good regulator.

The upper part of part C is solid, whereas the lower portion is hollow. The gas enters through a large opening (2) and passes down to 4, the minimum outflow, and to 5 and out at 3. The portion marked 6 is ground to fit exactly the corresponding part in B. If this is not done properly the minimum outflow of gas cannot be regulated as perfectly as it otherwise can be. The upper portion of C is a ground stopper fitting into B.

The manipulation of the thermo-regulator is very simple. The gas enters through the upper lateral tube. If it is desired to diminish the inflow of gas, this can be done by turning B. The gas passes through 1 into the inner space and leaves at 2. As stated above, the gas goes down, and a portion leaves through the minimum supply opening 4, while the remainder passes down through 5 and out at 3. By turning part C, the minimum outflow of gas can be regulated at will.

The regulator works exceedingly well, especially when connected to a gas-pressure regulator such as that of Mr. Murrill, a description of which follows.

Thermo-regulator of this type, excellently constructed, can be obtained from Greiner and Friedrichs, Stuetzerbach, Thuringen, for about 8 marks..

DR. F. G. NOVY.

From the Hygienic Laboratory of the University of Michigan, Ann Arbor, Mich.

An Efficient Gas-Pressure Regulator.

It is well known that the various types of mercury thermo-regulators cannot compensate for marked changes in the gas pressure, and for this reason it is almost impossible to maintain a constant temperature for any considerable length of time with any degree of certainty. Numerous contrivances for regulating the pressure have been devised at various times, and several are to be had from the principal dealers, but they either fail entirely in their purpose, or are impracticable for general use owing to cost, difficulties of construction, or other reasons. The apparatus of Moitessier, as catalogued in this country and

in Europe, appears to have some features in common with the one here described, but its cost bars it from general use. The Giroud Rheometer, modified by Schiff, was tested in connection

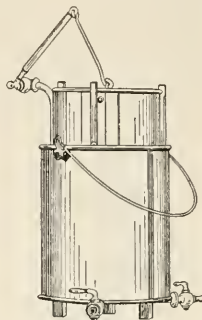

with a mercury thermostat, with results to indicate it as useless for that purpose. A pressure regulator made of glass, described by Schiff,* is quite similar in principle to the one here described, but has the disadvantages of being quite fragile, besides requiring skilled glass blowing in its construction. An apparatus by Knudsen is also described† but it is too complicated to be practical.

Having experienced the same difficulties that other workers have, the attempt was made to devise a simple apparatus which would deliver gas at

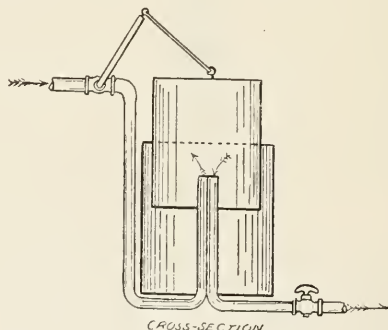

constant pressure, regardless of the various changes of pressure in the gas pipes. The apparatus having proved satisfactory, a description of it is given. Its strong points are efficiency, simplicity, durability, and cheapness. It can be made of sheet metal, preferably of copper, by any sheet-metal worker, or may be obtained from the Eberbach

* Ber. d. Chem. Ges. 1885, 2833; Ztschr. Anal. Chem., 1886, 385.

† Ztschr. Anal. Chem. 1886, 383.

Hardware Co., Ann Arbor, Mich., at a cost of about \$3.00. It is designed to be used in connection with a thermostat, and with it the temperature may be held constant within 0.1°C . With this apparatus and Novy's thermo-regulator, it is possible to maintain constant temperatures in an air bath at 50°C . and an oven at 150° at the same time. The dimensions can be varied to suit the purpose of the operator, but those here given will be found suited to the usual needs. The outer vessel or pail is six

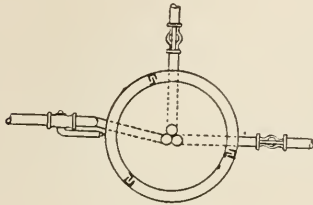

PLAN-TOP OF INNER
PAIL REMOVED.

inches (or 15 cm.) in diameter, and seven inches (18 cm.) deep. Through the center of the bottom, three tubes enter, rising five and three-quarter inches (14.5 cm.) above the bottom. Beneath it, the tubes bend at right angles and may diverge or run horizontally in any convenient direction. Two of these run a short distance beyond the vessel, terminating in stopcocks, and serve as exit tubes for the gas. The third, which is the inlet tube, bends upward at the lower edge and extends three inches (8 cm.) above the top of the outer vessel, turns outward at right angles again, and terminates in a stopcock placed horizontally. To this stopcock a four-inch (10 cm.) lever arm is attached. On the inside three vertical U-shaped grooves are soldered, extending three inches (8 cm.) above the top. The tubing should be not less than one-quarter inch (7 mm.) internal diameter.

The inner vessel or float is five inches (13 cm.) in diameter, and six inches (15 cm.) deep. On the outside three vertical flanges are soldered, corresponding to the three grooves in the outer vessel, and projecting sufficiently to prevent rotation or lateral motion of the inner vessel, but allowing it to move freely up and down. To the top of the float is soldered a stiff wire ring, and this is connected to the end of the lever arm of the stopcock described above, by means of a stiff wire of such length that the valve is wide open when the float is at its lowest position. The float with attachments should weigh about twenty-five ounces (700 grms.), under which weight the gas will be delivered at about

40 mm. pressure, but by means of convenient weights placed upon the float, the pressure at which the gas is delivered may be varied at will. In the laboratory here the maximum observed pressure in the gaspipes was 87 mm., and the minimum 40 mm., measured on a water manometer.

The outer vessel is to be filled with water to the depth of about 13 cm., five inches (less than the height of the tubes inside), or, if desired, glycerine or liquid paraffin may be used, thus avoiding evaporation. This apparatus may be improvised in any laboratory by using glass jars and tubes. Thus, two battery jars with straight sides and whose diameters differ by an inch serve as pail and float. Instead of entering through the bottom, glass tubing is bent as herewith shown (see Fig. 4), and

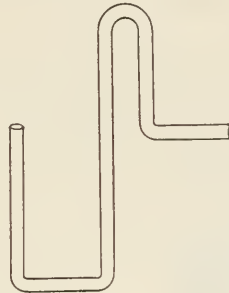

enters between the two vessels. Three such tubes are bent and placed at equal distances from each other. The tubing should have an external diameter a little less than half the difference between the internal diameter of the large jar and the external diameter of the small one, and should extend 10 cm. (four inches) above the top of the outer vessel, serving instead of the flanges and grooves. A glass stopcock with as large a bore as possible, is clamped rigidly in convenient position above the apparatus, and to it a lever arm of light wood is attached, which rests on the float and operates the valve.

The operation of the apparatus is as follows:

One of the exit tubes may be connected with a manometer, or both may go to burners as may be desired. Gas enters through the stopcock and long tube into the container or float, and in so doing lifts the float, at the same time closing the valve. If the outlets are closed, the float will rise until the valve is entirely closed, in which position it will stand. When the exit tubes are opened the float falls, reopening the valve, admitting gas at the same rate at which it is consumed, and delivering

it at a pressure which is measured by the weight of the float, plus or minus the resistance due to friction. If the apparatus is well made, the resistance amounts to only 1 or 2 mm. on the manometer, and it is only exerted during the changes of position of the float. If the pressure in the gas pipes falls to that in the apparatus, the float falls to the bottom, opening the valve to its fullest capacity, and allowing gas to flow through unhindered.

Thanks are expressed to Mr. J. T. Faig for the drawings herewith given, and to Professors P. C. Freer and F. G. Novy for assistance rendered in various ways.

PAUL MURRILL.

University of Michigan, Ann Arbor, Mich.

A Practical Photo - Micrographic Camera.

The desire among photo-micrographers to go to the extreme limit of enlargement, and the complicated and expensive apparatus required to obtain these results, has led the majority of microscopists to believe that no

good work can be done except with an equipment of a very expensive character and with an undue expenditure of time and labor. The result has been that this highly valuable aid to the investigator and instructor has not been employed to the extent which its usefulness would warrant. The form of camera illustrated in the accompanying figures has been designed for working microscopists, i. e., biologists, pathologists, and others to whom the microscope is a necessity. The object aimed at is to give as much magnification as is compatible with the requisite compactness and stability in order to make the apparatus convenient and rapid to use. In order to secure stability the base is a solid iron plate upon which the microscope rests (any microscope may be used with this camera), and above which the camera bellows is supported on two solid steel rods three-quarters inch in diameter, and thirty inches long. The bellows has an extension of eighteen inches and is supported at either end on cherry frames.

The ground glass is provided with a central transparent area, formed by cementing a cover glass upon the ground glass, and permits the accurate focusing of the most delicate detail. In order to make it possible to use the camera in any position with equal facility, the vertical rods supporting the bellows are attached to very heavy metal arms which are immovably fixed to a horizontal axis, thus permitting the camera to be tilted to any angle from vertical to horizontal. It is fixed at the desired angle by means of the two heavy hand-clamps shown in the figure, the construction being such as to secure perfect rigidity. The camera is made for 4X5 plates, but lantern-slide sizes can be used by means of kits.

In use, the camera is placed in a vertical position and the microscope adjusted on the base so that its tube will coincide with the opening in the front of the camera. The connection between microscope and camera is made light tight by means of a double chamber which permits considerable vertical motion of the tube of the microscope without readjustment. In order to make this camera usable with any sized microscope and with the camera in any position, the upper and lower frames supporting the bellows are laterally adjustable, and graduations indicate when both are centered. A jointed telescoping rod is attached to the upper end of the camera to act as a support, giving perfect steadiness when in a

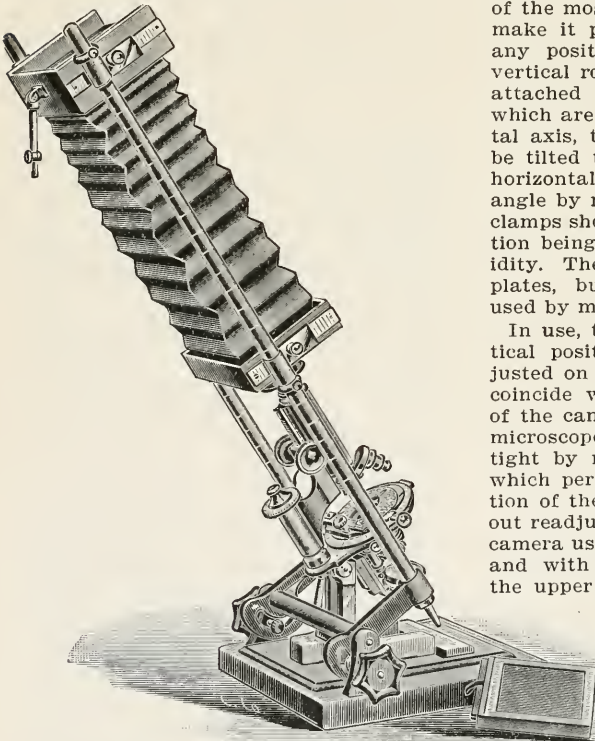

Fig. 1.

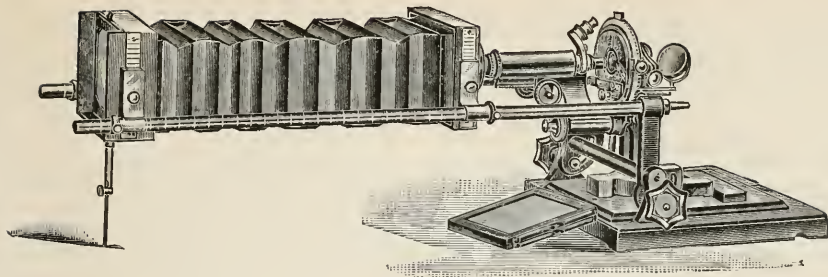

Fig. 2.

horizontal position, and folding down parallel with the bellows so as to be out of the way when in any other position. The vertical rods are graduated in inches for determining the amount of amplification and to show when the ground glass is at right angles to the optical axis. The following simple rule for determining the amount of amplification, will give sufficiently accurate results. When photographing without the eyepiece, divide the distance of the ground glass from the stage of the microscope in inches by the focal length in inches of the objective used. When photographing with the eyepiece, proceed as above and multiply the quotient obtained by the quotient obtained by dividing 10 by the focus in inches of the eyepiece used.

A valuable feature of this camera is that the microscope can be placed in any position desired and the camera adjusted to it. The bellows can then be raised and the microscope used as though no camera were present. When an object is to be photographed, the bellows may be slid into position without in any way disturbing the arrangement of light or object, the final focusing on the ground glass being effected quickly by means of the fine adjustment screw. The exposure having been made, observation through the microscope may be continued without interruption by simply raising the bellows again. The use of the two supporting rods for the camera

gives the necessary steadiness to the sensitive plate during exposure which it is very difficult to obtain in the vertical or inclinable camera in any other way.

Figure 1 shows the camera in the inclined position; figure 2, as it would be used horizontal.

H. BAUSCH.

Rochester, N. Y.

ABSTRACTS.

Copper Crystals in Adventurine Glass.*

The material is known to the jewelry trade as "gold stone." Mr. James Walker, of the Brooklyn Institute, informs me that an English work gives oxide of copper as the compound used in its manufacture.

One of the most curious products of the world-renowned glass works at Murano, near Venice, is the so-called "adventurine glass" (*vetro aventurino*), which owes its name, according to the story, to its discovery by chance (*all'avventura*), some brass filings having been dropped accidentally into a pot of molten glass.

The glass is of a copper brown color, and transparent to translucent, in thin flakes, showing on the edges a pale brown color. It is filled with innumer-

* From American Journal of Science, Nov., 1894, by Henry S. Washington, Venice, Italy.

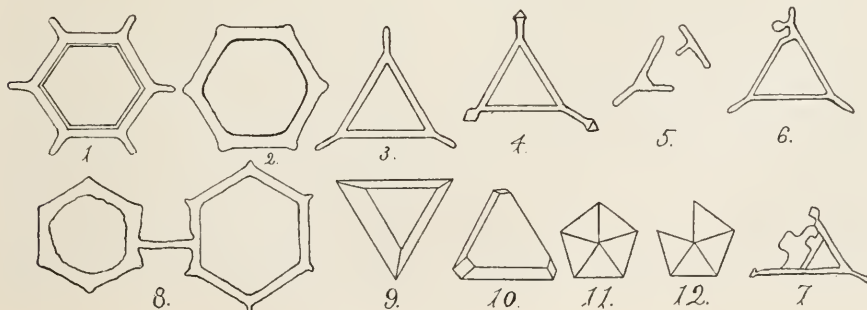

able small flakes and spangles of a slightly brownish yellow color and brilliant metallic luster. This shows under the microscope a posphyrritic structure, the ground mass being composed of a perfectly clear and colorless glass basis. The crystallized portion of the mass consists entirely of copper and may be divided sharply into three distinct groups, large phenocrysts, small phenocrysts, and microlites which differ greatly from each other, both in the size and in the habit of individuals. All of the large phenocrysts, which range in diameter from .05 mm. to 12 mm., are tabular and extremely thin, the thickness scarcely exceeding .002 mm., and often less than half this, being perfectly opaque, notwithstanding their excessive tenuity. Most of them are hexagonal in outline, the hexagons being of almost ideal symmetry; and equilateral triangles, which occasionally show truncated angles, also occur. They show a rather yellowish copper color and in reflected light a brilliant metallic luster.

The faces of these hexagons and triangles are in general perfectly smooth and plane, but a number show a peculiar appearance (Figs. 1 to 8). In such cases we see that the central part of the face is depressed, forming a very shallow hexagonal or triangular pit, symmetrical with the crystal line, and surrounded by a salient edge about .004 mm. broad, and with sloping and rounded sides. The angles of these shallow depressions are generally rounded, so much so in some cases that they assume an almost circular form (Fig. 2). It may be remarked that such shallow pitted surfaces are not rare in native copper crystals, and quite common in gold. This peculiar form, which seems to be due to a skeleton growth, is always accompanied by projections of greater or less length at the outer angles of the tabular crystals, as shown in the figures. These projections are in general rounded and show no crystal faces, but in a few cases (Fig. 4) they are seen to be minute octahedra.

In addition to these more regular forms, some skeleton crystals are to be seen (Figs. 5, 6, 7), which are made up of narrow ridges and show that the pit-like depressions are due to incomplete growth, and not to corrosion. A curious and quite unique form is shown in Fig. 8. This is a "Siamese twin" of the hexagonal tables joined together by a narrow ridge.

The copper crystals making up the second group are smaller than the preceding, varying from .01 to .03 mm. in diameter, and are not only quite different in habit, but much more diverse in form.

The third type, that of twinned forms, while of about the same size, offer much more variety. The twinning plane is in every case the usual one, an octahedral face, and the twins are either simple or repeated. The simple forms are shown in Figs. 9 and 10.

The polysynthetic twins are either fivelings or fourlings (Figs. 11 and 12), formed of either five or four octahedra grouped about a common center, the latter showing a re-entrant angle at one side, and the fivelings forming almost symmetrical pentagonal bi-pyramids, since the octahedral angle ($70^{\circ} 32'$) is almost one-fifth of 360° .

It seems that the glass is produced by melting together glass, cuprous oxide and some reducing agent, such as siderite, Fe CO_3 , and that Fe O is in this case the reducing agent is shown by the greenish color of the imperfect glass, which is not the blue-green of copper, but the yellow-green of ferrous glass and perhaps due to too large a quantity of reducing agent.

ROY HOPPING.

New York.

The Aseptic Cultivation of Mycetoza.

As supplementary to Dr. Ayers' article on "Methods of Study of the Myxamobae and the Plasmodia of the Mycetoza," published in the January number of this journal, a brief review of Dr. Casper O. Miller's paper with the above title, published in the quarterly Journal of Microscopical Science, vol. 41, part 1 (March, 1898), 29 pp., 2 pl., may be of interest.

This investigation was undertaken in the course of a study of the kinds of protozoa which are found in the air. According to the critical portion of his paper, Miller appears to have developed the most elaborate method of studying the mycetoza yet brought forward. The method would seem to promise "pure cultures," yet he says, "Bacteria are found in all the cultures," and promises in a future paper to discuss their influence upon the growth of mycetoza. The following species were cultivated: *Physarum cinereum*, *Stemonitis* sp., *Chondrioderma difforme*, *Didymium microcarpum* and *Aethalium septicum*. The spores of these were planted in the culture medium and the course of development traced from the Zoöspores to the formation of plasmodia, and finally the production of sporangia. After trying several methods, the author finally decides upon the following as the best: A handful of hay is placed in a jar and washed repeatedly until the water remains colorless. It is then covered with fresh water and allowed to soak

over night. The following day the water is poured off, filtered, diluted with fresh water until it is of a white wine color, and two per cent. of milk is added to the infusion. It is then filtered, put into a flask, and sterilized for future use. The macerated hay is cut and placed in Erlenmeyer flasks; the first portion is cut short enough so as to form a tolerably compact layer in the bottom of the flask to the depth of one centimeter; the rest is cut sufficiently long to form a very loose layer reaching about two-thirds the way up the sides of the flask, care being taken not to let any of the stems reach the cotton. Sufficient water is placed in the flasks to cover the hay, and they are sterilized for fifteen minutes. On the following day fresh water is substituted, and they are again sterilized. The water is once more poured off, and enough of the hay infusion and milk previously prepared is added until it is about one centimeter deep. The flasks are then sterilized in a steam sterilizer for ten minutes on three successive days. They are then ready for use.

After soaking the hay for twenty-four hours in water, and boiling it several times in fresh water, about all of the soluble substance has been extracted, and the diluted hay infusion with two per cent. of milk is added. We thus have a medium of tolerably uniform composition.

Of the cultures gotten from the air several contained mould fungi, which were eliminated by putting the cultures in the oven at a temperature of 37°C.

One culture contained Chroococci, and these were eliminated by keeping a series of cultures in a dark closet. It is not possible in every case to eliminate other protozoic forms that may be present, but one may at times succeed by taking advantage of the fact that the encysted forms withstand drying. In this way one may sometimes succeed in separating mycetozoa from the infusoria, amoebae, and other protozoic forms found in hay infusions.

The cultures are usually transplanted by means of a sterilized pipette. The plasmodia form on the hay at the surface of the water or on the glass. Previous to forming the sporangia, they crawl up above the surface of the water, sometimes (*Physarum*) covering the entire inner surface of the flask, but not extending over upon the cotton plug. The sporangia of the various species formed in from twelve hours to thirty days. The sporangia are more numerous when many, rather than few, stalks of hay project above the surface of the infusion. "As a rule, but one set of sporangia developed in the same cul-

ture. Sporangia do not develop in all cultures; at times large plasmodia form on the hay and degenerate without forming sporangia." The formation of sporangia is favored by keeping the cultures in the light.

As to the manner in which the large plasmodia are formed, the author states that while he does not question the "accuracy of the observations of such competent observers as Cienkowski, Strasberger, Lister, and others," who have seen, figured, and described the fusion of zoöspores, he himself has seen nothing of the kind, though he has at times watched on the slide the coalescence of fairly large plasmodia into still larger ones. Referring to this point he says, "What takes place in the culture seems to be as follows: the bacteria multiply at the expense of a portion of the nutrient material; the zoöspores multiply at the expense of the bacteria; and possibly some nutrient material which was not consumed by the bacteria; the majority of the zoöspores encyst, small plasmodia develop from a single zoöspore or by the fusion of several zoöspores; the plasmodia take in and digest active and encysted zoöspores and bacteria; finally, the small plasmodia fuse to form the large plasmodium." The author saw the zoöspores capture bacteria and particles of carmine by the stroke of a flagellum, which threw them into a funnel-like depression in the protoplasm, the sides of the depression then closing, thus forming a vacuole. The fission of the zoöspores was also seen. For microscopic study plasmodia were placed on the slide in a few drops of the infusion and covered with a cover glass supported by wax feet. They may be fixed and hardened on the slide by using picric and acetic acids, and stained in picro-carmine.

CHARLES WRIGHT DODGE.

University of Rochester.

Staining Yeast.*

Stain for fifteen minutes in alum-haematoxylin, wash in water, and then stain with very dilute phenol fuchsin (one part Ziehl's Solution, twenty parts distilled water) for thirty minutes to twenty-four hours. After this, decolorize and dehydrate for fifteen seconds to one minute in alcohol, then ninety-five per cent. followed by absolute alcohol, xylol, and balsam.

* O. Busse, *Central-Bl. Bakt. u. Par.*, XXII, P. 349.

If pleased with the Journal, give us your support—financially.

Journal of Applied Microscopy.

Issued Monthly from the Publication Department
of the Bausch & Lomb Optical Co.,
Rochester, N. Y.

L. B. ELLIOTT, EDITOR.

Address all communications to
PUBLICATION DEPARTMENT,
BAUSCH & LOMB OPTICAL CO.,
ROCHESTER, N. Y.

ONE DOLLAR PER YEAR.

To Foreign Countries - - \$1.25 Per Year.

Entered at the Post-office, Rochester, N. Y., as second-class matter.

MAY, 1898.

EDITORIAL.

As there is at the present time no directory of the users of the microscope, the question arises whether it would not be of material benefit to those interested, biologists, histologists, pathologists, petrographers, chemists and all classes who in any way require the microscope, to have such a directory.

The Journal desires an expression of opinion on the subject with a view of publishing as complete a directory as possible for 1899 if sufficient encouragement is received.

A good directory would furnish a ready means of communication between the users of the microscope, so that exchanges of material and experience might be readily effected.

NOTES AND QUERIES.

This space is intended for inquiries regarding subjects not otherwise touched upon. Answers to inquiries will be published over the signature of the writer.

Permanence of Stains.

In reply to an inquirer, I wish to say that the question he asks is one of deep interest to me, as it must be to many others, also those who are engaged in making museum collections of a histological and embryological nature.

The defect of fading is caused mainly by two factors: The chemical susceptibility of the stain to fading; the manner of mounting the specimen, whereby conditions are produced favorable or unfavorable to fading.

The first factor I will not discuss

beyond mentioning my observation that the carmine stains and safranin seem to be the most permanent colors. The second factor is the key to the problem, and two conditions must be taken into account: First, the mounting medium; second, the area of the specimen as compared with the area of its cover glass.

The usual mounting medium varies in many particulars, some of which must be very active in aiding or hindering fading. Acidity is a common and fatal defect in balsam. Other still undetermined ingredients must also hasten fading.

Again, besides deleterious constituents of the mounting medium itself, fading is caused by the penetration of some reagent (probably oxygen, chlorine, or some other gas) beneath the edge of the cover glass and through the balsam. This occurs slowly and is performed by diffusion, as is shown by the concentric fields of fading which begin and are strongest at the edge of the cover and which extend slowly inward or centrifugally. Two remedies are suggested: The ringing of the slide with some thick, hard ring, and the use of large cover glasses to prevent the encroaching gas from reaching the specimen so quickly. The first has seemed to be of value, especially when Brunswick black was used for the ring. The second has apparently proved less useful because the outer field of balsam is hard and only permits of the entrance of the gas by diffusion, while the central field in which the specimen lies is still fluid (vide any broken cover glass on an old specimen), and here convection currents hasten the penetration of the gas. The following experiments are being carried on in the Laboratory of Histology at Princeton by the writer, and in them the processes which in time usually bring fading about are performed under exaggerated conditions, thus reducing the time element and enabling us to learn quickly facts concerning fading which otherwise could only be acquired in long years and at the expense of the ruin of valuable collections made during these same years.

Specimens prepared alike in every detail are submitted to the following conditions and the results compared: They are mounted in different media, especially different balsams; they are exposed to full sunlight, to room daylight, and to darkness; they are exposed in sealed jars to oxygen gas, to chlorine gas, and other gases liable to be found in the laboratory; they are mounted under cover glasses of different diameters.

ULRIC DAHLGREN.

Princeton, N. J.

Journal of Applied Microscopy.

VOLUME I.

JUNE, 1898.

NUMBER 6

Fixing and Imbedding Lichens.

For many years lichens have been studied by descriptive and systematic botanists mainly. Although a few morphologists and physiologists have made important contributions to our knowledge of these interesting associations of organisms, the great number of problems in plant morphology and physiology to which the study of more rapidly growing, larger, and simpler structures promised a speedier solution, have caused the lichens to be more or less ignored by investigators. When any attempts to study them have been made, various technical and other difficulties have tended to discourage the investigator. The excessively slow growth of lichens not only tries one's patience, but it also very greatly increases the danger of culture experiments becoming failures through the invasion of the more prolific bacteria and moulds.

Even the study of their microscopic anatomy is attended with unusual difficulty, and comparatively seldom, if at all, have modern histological methods been applied to them. Yet the careful study of their minute structure would not only settle the disputed points as to the nature of the lichen association and the reproductive parts, but would suggest and prepare the way for physiological studies of no slight importance. Since De Bary and Schwendener convinced botanists (and even the "lichenologists") finally that lichens are composed of two very different kinds of plants, green or blue-green algae, capable of manufacturing their own food from inorganic materials, and fungi, absolutely dependent upon already prepared food, there has been no agreement as to whether, as Reinke claims, these associations are sufficiently intimate and independent to justify their being called autonomous, or whether, as many believe, they are composed of two kinds of plants mutually benefited by being

associated; or, again, whether the association is simply that of host and parasite. Careful study of the structure of these associations, and culture experiments upon the component organisms, will settle the question.

For the study of lichen structure, I have found proper fixing and careful imbedding to be indispensable. I have been most successful with a concentrated (or saturated) solution of corrosive sublimate in thirty-five per cent. alcohol. This I use hot, which secures very rapid penetration, killing, and fixing, during and after which no contraction need take place. If the lichen material is air dry, but still alive, it should be thoroughly wetted and kept moist for two or three days, and then small pieces only should be put into the hot fixing agent, in which they will promptly sink to the bottom, where they may be left for a suitable length of time—from five minutes to half an hour. Slow dehydration in the alcohols, using five or six grades and comparatively large volumes in proportion to the size of the objects, will secure the removal of the last traces of corrosive sublimate.

After absolute alcohol, alcohol-xylo (equal parts), and pure xylo, imbedding may be begun. For many lichens a harder grade of paraffin must be used than for most vegetable structures. A mixture of hard and soft paraffin which melts at about 60°C. is to be recommended. To the pure xylo in which the material has already become clear, small pieces of paraffin may be added, keeping the dish warm at the same time, both to increase the solvent power of the xylo and also gradually and finally to evaporate it all. By this means the material is slowly warmed and penetrated with paraffin. After remaining in melted paraffin absolutely free from xylo for three hours, the objects may be imbedded. The sections should be very thin, and before cutting, the block should be chilled to

somewhat below 20°C. The microtome knife or razor must be very hard, sharp, and rigid, for the material is now brittle to a greater degree than most plant tissues. Staining on the slide by any of the usual methods is easy and the results satisfactory.

GEORGE J. PEIRCE.

Assistant Professor of Plant Physiology, Stanford University, California.

A Note on the Detection of Maize Starch and Maize Flour in Mixture With Wheat Flour.

E. E. EWELL.

Contributed by H. W. Wiley.

During the past few months there has been much discussion in commercial and legislative circles concerning the use of maize products for the dilution of wheat flours. It is claimed that the addition of a well prepared maize starch to wheat flours increases the power of the latter to endure storage in warm and moist climates in exactly the same way that an addition of starch to a baking powder insures its keeping qualities. On the other hand, it has been urged that a considerable portion of the dilution of wheat flour with maize products is done with a less praiseworthy motive. It seems to be a fact that the sale of wheat flours adulterated with maize is still largely confined to Southern markets. Two samples of flour which were suspected of containing maize have been sent to us for examination from the Gulf states. Both contained a considerable proportion of maize starch. On the other hand, we have just finished the examination of forty samples of flour of various grades, recently purchased from wholesale and retail grocers in Washington, D. C., including some of the best stores in the city, as well as small establishments in the humbler quarters, and with two exceptions, found no evidence of admixture with maize in any of the samples. In both of these samples the maize was present in small amount, and in the form of rather coarsely ground particles. In one of these cases the presence of the maize was traced to careless storage in the small store at which it was purchased; as the other sample also contained a number of whole grains of rice, it is quite probable that its foreign ingredients were accidentally added.

The fact that maize products are used to a considerable extent in some parts of the country for the dilution of wheat flours, for one purpose or another, makes it desirable to develop the most convenient and reliable methods for the detec-

tion of such mixtures. Various methods have been suggested for this purpose, depending upon the "feel" of the flour when dry and when kneaded with water, etc., but the microscope must be considered the only instrument at present known that will give reliable results in every case. Wheat flours are not always as finely ground as many persons suppose. Maize starch is added in the form of ground white maize of various degrees of fineness or in the form of maize starch, which may be made from maize of any variety, and which will possess a "feel" varying with its physical condition, which is in turn dependent upon the purity and method of manufacture; and the amount of admixture may vary within wide limits. All of these circumstances tend to limit the value of any test which does not enable us to study the form and size of the individual starch grains of the material. While the task of a microscopic examination is easier, the greater the percentage of the substance sought, very small percentages of maize starch may be very readily detected in wheat flours if a thorough search is made.

Dr. C. Urban Smith* has stated that as low as two per cent. of adulteration can be detected by this means. Our own work indicates that this delicacy can readily be attained or even exceeded; this is especially true if the adulterant is added in the form of high grade maize starch.

In many cases the microscopic examination may be greatly facilitated by sifting the flour through bolting cloths having meshes of different sizes, and by examining each portion thus separated. It must be remembered, however, that the maize starch will not always accumulate in the coarsest portions of the sifted material.

A mixture of equal volumes of water and glycerol and fifty per cent. acetic acid† have been suggested as mounting media appropriate for the microscopic examination of starches and flours. The diluted glycerol possesses the advantage that it evaporates but very slowly; acetic acid brings out the structures of the foreign starch grains somewhat clearer than do water or diluted glycerol.

In consequence of the possibilities of imperfect mixing and the danger of missing coarse particles, it is important to thoroughly mix the sample before proceeding with the examination, and to use a considerable portion of it for preparing the mixture with the mounting medium. To this end, place from one to ten grams of the material in a

* Health Magazine, 1898, 5, 286.

† Dr. C. Urban Smith, Health Magazine, 1898, 5, 286.

small vessel and thoroughly stir with a sufficient quantity of the mounting fluid to form a stiff cream. Transfer a drop of the mixture to the glass slide and dilute with a small drop of the mounting fluid before applying the cover glass.

The microscope used should place at the operator's disposal powers varying from 325 to 450 diameters, and should be provided with a polarizing apparatus. An eyepiece micrometer is also of value, especially so if rice and other starches having polyhedral grains are to be looked for.

While textbook illustrations and descriptions are of value, they should not be relied upon for a knowledge of the characteristics of starches. A careful study of pure materials likely to be found in the mixtures to be examined cannot be neglected with safety in any microscopical examination.

While the grains of wheat starch do not usually show the characteristic cross under the influence of polarized light with marked distinctness, almost every sample of pure wheat flour will be found to contain an occasional grain of starch that will show as bright a cross as do the average maize starch grains. By careful examination, however, it can usually be noted that the angles between the arms of the cross seen on grains of wheat starch are decidedly different from those seen on grains of corn starch. The microscopic appearance of the starch grains of the common cereals is found in part nine, bulletin thirteen of this division, now passing through the press.

Laboratory of the Division of Chemistry, U. S. Department of Agriculture, Washington, D. C., May 24, 1898.

A Simple and Convenient Method for Demonstrating the Circulation of the Blood in the Capillaries.

For several years the writer has used tadpoles to demonstrate capillary circulation, both in the external gills (which are absorbed ten days or two weeks after hatching) and in the transparent tissue of the tail. These show the branching of the arterioles remarkably well; and the systole and diastole of the heart are plainly noticeable in the alternating increase and diminution in the rate of flow of blood in the capillaries—especially in those of the gills. In the latter, the blood goes up on one side of the gill and down on the other, in jerks like the cups in a chain-pump moving by jerks.

Tadpoles are more readily accessible than frogs, smaller and more easily manipulated, and their tissues thinner and more transparent than is the web of the frog's foot, so often used for this purpose. Until this spring I had difficulty in keeping them still enough to demonstrate the circulation to freshman and sophomore students who have had little experience in the manipulation of the compound microscope; but an accidental discovery obviated this difficulty, and I give it now in the hope that it may be of assistance to teachers and to others who may have to work under similar difficulties.

I spoke to a friend of this difficulty of keeping the tadpoles still, and he suggested that I try pinning them down. This I proceeded to do, and first thought of pinning the specimen on paraffin and examining with the top light, but my eye chanced to fall upon some thin, transparent sheets of celloidin which I had bought for embedding purposes, and I concluded to try this. I pinned one specimen to celloidin, but the experiment failed, either because the sticking stopped the circulation or because I did not take time to focus properly, as I was in a hurry.

I next placed a moist tadpole on the celloidin without pinning and without using a cover glass. The experiment was a perfect success. The water softened the celloidin and made it sticky, so that the tadpole's tail became glued hard and fast. By adding a drop of water from time to time, I used the same specimen to demonstrate capillary circulation to two consecutive sections of my zoology class. Mount moist, not using too much water, and examine with a two-thirds inch objective.

Celloidin may be purchased of any dealer in microscope supplies, but that sold by Schering and Glatz of New York is said to be the best for embedding purposes.

T. O. MABRY, M. A., M. S.

Dept. of Natural History and Geology, University of Mississippi, May 24, 1898.

PLEASE FILL OUT THE BLANK
ON PAGE VII.

Duplicate blanks with return postage will be mailed on request, as we intend to make the Directory as complete as possible. Send the names of all interested in the microscope.

Notes on Microscopical Technique.

G. CARL HUBER, M. D.

Fourth Paper.

Perhaps no branch of microscopical technique presents so great a variety of methods as that of staining. Nearly all known stains have some time or other been used and recommended as general or special stains. It is not to be supposed, however, that it is necessary to know even a major portion of these methods in order to do useful work. Indeed, even in the histological laboratories, many of the methods are never used, others only in rare and very special instances. The great bulk of the work is carried on with very few methods, and, as it seems to me better to be able to follow one or two methods with some degree of confidence than to have a casual acquaintance with a number of methods, I shall confine my account to only a very few of the many staining methods known. Before detailing, however, the methods to be discussed, a few general remarks on the staining of tissues may not be out of place. The majority of stains used in microscopical technique may roughly be divided into "nuclear stains" and "protoplasmic or general stains." The former stain more particularly the nucleus, the latter shows a selective action toward the protoplasm. In explanation of these facts, the following considerations are offered:—it is well known that not all the constituents of the nucleus show a selective action toward nuclear stains, but only that portion which, owing to its affinity to these stains, is known as the chromatin, and the chromatin is, roughly speaking, composed largely of nucleic acid. Now, it is well known that the nuclear stains belong, as a general rule, to that group known as basic stains. Many of the stains may, however, be regarded as salts. In some of these salts, the acid radicle is instrumental in bringing about the stain, and such stains are grouped under the head of acid stains. They show an affinity toward the protoplasm of cells, or toward cell products, while in other stains the base does the staining; these are the basic stains. These show an affinity toward the nucleus, that is its chromatin, because the nucleic acid forms a chemical compound with the stain, which has some stability and which is not broken down or materially changed by the further manipulation of the section. Nuclei rich in chromatin stain deeply, and vice versa. The nuclear configuration depends on the arrangement of the chromatin in the nucleus. It is not to be supposed, however, that the nuclear stains color only the nucleus. Nearly all of them

color the protoplasm more or less, but they do not form so firm a compound with the protoplasm, if any is formed at all, and are therefore more readily washed out of it than out of the nucleus, either with water or alcohol, some acidulated solution or with an acid stain.

Of the nuclear stains none have a wider applicability and are more generally used than the solutions of haematoxylin. For general work the following solutions are recommended:—

Boehmer's Haematoxylin Solution.

Sol. No. 1—

Haematoxylin crystals, 1 gram.
Absolute alcohol, 10 ccm.

Sol. No. 2—

Potash alum, 10 grams.
Distilled water, 200 ccm.

Solution No. 1 is prepared by mixing the haematoxylin crystals and the alcohol in a well stoppered bottle, shaking occasionally and allowing it to stand for twenty-four hours.

Solution No. 2 is prepared by dissolving the alum in warm distilled water, and allowing this solution to cool.

Mix solutions one and two in a large open dish, stirring constantly while mixing. Allow to stand for about a week and filter into a clean bottle. The stain is then ready for use.

Practically the same stain may be made after the following formula, known as Meyer's Hemalum Solution:

Hematein, 1 gram.
90% alcohol, 50 ccm.
Potash alum, 50 grams.
Distilled water, 1000 ccm.
And a small crystal of thymol.

Dissolve the hematein in the alcohol by the aid of heat. Dissolve the alum in the water; hastening by warming the water. Mix the two solutions, stirring while mixing. Add the thymol crystal. This solution has the advantage of being ready for use at once, and does not precipitate as does Boehmer's haematoxylin after standing some weeks. Either solution will, however, stain readily for many months. It is well, however, to filter the stain before using.

Acid or Protoplasmic Stains.—Of the acid stains which may be used as counter or double stains to the nuclear stain obtained with haematoxylin, none are more useful than a solution of eosin, and a solution made of picric acid and acid fuchsin.

Solution of Eosin.—As there are a number of preparations of eosin in the market, some of which will hardly stain at all, while others stain very readily, it may be well to state that in this laboratory we have used for some time an eosin

sold by Gruebler (Leipzig, Germany), known as "eosin blaueulich" (of bluish color), soluble in water. Of this a one per cent. solution is made in distilled water, that is, one gram to one hundred cubic centimeters of the water.

Picric acid—acid fuchsin solution (Van Gieson's Stain).

1% acid fuchsin solution in distilled water, 5 to 7 cc.

Saturated aqueous solution of picric acid 100 cc.

STAINING OF SECTIONS WITH THE SOLUTIONS DESCRIBED.

Paraffin Sections.—In order to stain paraffin sections readily, it is desirable to remove the paraffin from the sections before staining. Before doing this, however, it is well to fix the sections to slides or cover-glasses, preferably the latter, otherwise the sections become somewhat difficult to handle; they are apt to tear, or some of the cells or nests of cells, loosely adherent to the surrounding tissue, are likely to be lost in the manipulations.

The process followed in this laboratory for fixing sections to a cover-glass is as follows (cover-glasses are as a rule used because they are more easily manipulated, require less of the solutions, etc.); it is essential that the cover-glasses be perfectly clean before they are used for this purpose. They may be cleaned by placing them for a few moments in sulphuric acid, rinsing off the acid and pouring on strong acetic acid, and after shaking the dish or beaker a little while, the acetic acid is poured off, and the cover-glasses are thoroughly washed in flowing water, if that is at hand, or by frequently changing the water on the cover-glasses. After thorough washing they are placed in alcohol, and the alcohol wiped from them with a clean, soft linen cloth. A large number of cover-glasses may be cleaned in this way at one time and kept in "pill-boxes," ready for future use.

As paraffin sections are usually somewhat folded or wrinkled when taken from the knife, especially if large, the following routine method has been followed in this laboratory for flattening out paraffin sections. A small evaporating dish, 4 or 5 inches in diameter, is nearly filled with distilled water. This is placed on a support, high enough so that a Bunsen burner or an alcohol lamp may be placed under the dish. One or two of the paraffin sections are then floated on the distilled water. The water is then carefully heated until the sections and the paraffin surrounding the sections become perfectly flat. Care should be taken not to heat the water sufficiently to cause the paraffin to melt. As soon as the sec-

tions are flat, the flame should be removed. Other sections may now be placed on the warmed water, and as soon as flat may be taken up on a cover-glass which has been coated by a very thin layer of "albumen fixative."

Albumen fixative is a mixture of equal parts of the white of egg and glycerine, and is prepared by chopping up the white of one or two eggs in a beaker with scissors and stirring in an equal quantity of pure glycerine. The mixture should then be filtered through fine linen into a clean bottle. The bottle should be provided with a cork through which a small glass rod has been pushed. A very small drop of this fixative is placed on each cover-glass to be used, and spread with the finger into a very thin layer. A cover-glass coated with albumen fixative is now taken up with a pair of cover-glass forceps and slipped, albumen fixative side up, under one of the sections floating on the warmed water, and while withdrawing the cover-glass, the section is drawn on to it with a needle or small camel's hair brush. The excess of water is now drained from the cover-glass by holding its edge to a filter paper. A little practice enables one to fix to cover-glasses, after this method, twenty or thirty sections in a very few minutes. The cover-glasses to which sections have been fixed are now set aside until all the water has had time to evaporate. Five to eight hours are sufficient, depending somewhat on the temperature and the dryness of the room. This step may be hastened somewhat if the cover-glass preparations can be placed in a warm oven, the temperature of which should not, however, exceed 40° C. When the sections fixed to the cover-glasses are perfectly dry, the paraffin is removed as follows:

A cover-glass to which a section is fixed is grasped in the cover-glass forceps and held over the flame until the paraffin in and around the section is melted, care being taken not to overheat the preparation. The cover-glass is now placed in xylol, where it remains until the paraffin is dissolved out of the section fixed to it. This usually takes only two or three minutes. The xylol is now drained off by holding the edge of the cover-glass to filter paper, and the cover-glass is transferred to absolute alcohol, this to remove the xylol from the section. It is next transferred to 95% alcohol and then to distilled water, allowing to each step two or three minutes.

It is convenient to arrange the dishes required to hold the fluids for the preceding and succeeding steps in one or two rows on a sheet of filter paper. The cover-glasses can then be transferred from one to the other with little incon-

venience and with little loss of time. It should of course be borne in mind that the dishes containing the alcohol and xylol should be covered when not in use. From the distilled water, the cover-glasses with sections fixed to them are transferred to one or the other of the haematoxylin solutions above described. In the stain they remain from fifteen to thirty minutes, are then rinsed in distilled water and transferred to an acid alcohol solution. This solution is made by adding six to eight drops of hydrochloric acid to 100 ccm. of 70% alcohol. As soon as the haematoxylin stained sections are placed in this acid alcohol solution, their purplish-blue color changes to a reddish-brown, and a reddish-brown stain is given off from the section. The washing in the acid alcohol is continued until very little of this stain is given off from the preparations. This step has for its purpose the washing out of the stain from all portions of the tissue except the nuclei. After washing in acid alcohol the cover-glasses are transferred to water—not distilled water, but ordinary tap water. This washes out and to some extent neutralizes the acid alcohol in the sections. In the tap-water the sections again assume a purplish-blue color of a lighter hue, however, than before the decolorization.

The steps for counter staining in eosin are as follows: Transfer the sections, stained in haematoxylin and decolorized, from the water into the eosin solution, where they remain for three to five minutes, then wash thoroughly in distilled water and transfer to 95% alcohol. For counter staining with Van Gieson's solution, place the haematoxylin stained and decolorized sections in this solution for twenty to forty seconds, wash in distilled water and transfer to 95% alcohol. The sections counter-stained in either the eosin or Van Gieson's solutions remain in the 95% alcohol, for two or three minutes, and are then transferred to absolute alcohol, where the sections are fully dehydrated, about three to five minutes are required. The preparations are now cleared in some clearing agent of which a number are in use. They are all substances which displace the alcohol from the sections and are solvents for the balsam used in mounting them, thus assisting in the penetration of the balsam. They are known as clearing agents, however, because they all have

a high refractive index, and literally make the sections clear. In this laboratory, oil of bergamot is used for this purpose. Oil of cloves, oil of origanum or oil of cedar may, however, be used. The sections remain in the clearing agent two to three minutes. Cover-glass preparations, i. e., sections fixed to a cover-glass and stained as here detailed, are best washed or rinsed in xylol before mounting; this insures a clean surface to the cover-glass when finally mounted.

Cover-glass preparations are mounted by placing a small drop of Canada balsam on a slide and placing the cover-glass, section side down, on the balsam.

This method of staining may seem somewhat lengthy, and we admit there are shorter methods. The sticking of sections to a cover-glass and the staining of sections fixed to the cover has, however, its advantages. The readiness with which such sections are transferred from one fluid to another; the fact that portions of the tissue are not likely to be lost; sections cannot fold nor tear; are readily mounted; these are all considerations which go far to compensate for the extra time and extra manipulation required to follow the method. It should also be stated that if the sections are small, a number of sections may be fixed to the same cover-glass by drawing, instead of one, several sections on to the cover-glass after they have been flattened on the distilled water.

Staining of Celloidin Sections.—Celloidin sections are stained as are the paraffin sections, remembering of course that they need not be fixed to cover-glasses, as the celloidin does not interfere with the staining, and does not, therefore, need to be removed. They are best carried from one solution to another by taking them up on a teasing needle. For clearing celloidin sections, I would recommend the use of carbol-xylol. This is prepared by mixing one part of pure carbolic acid with three parts of xylol. The stained sections are transferred from the 95% alcohol to the carbol-xylol solution, and from this solution in which they need to remain only a few minutes, to a clean slide, this by taking up the section on a section lifter, and drawing it off on to the slide. They are mounted by draining off the excess of carbol-xylol, placing a drop of Canada balsam on the section and covering it with a cover-glass.

THE FOLLOWING SCHEME MAY BE OF AID IN FOLLOWING THE METHODS HERE SUGGESTED FOR STAINING PARAFFIN AND CELLOIDIN SECTIONS:

Paraffin Sections.

Celloidin Sections.

Fix paraffin sections to cleaned cover-glass by floating on warm distilled water and take up on cleaned cover-glass coated with albumen fixative; allow to dry.

Place celloidin sections in distilled water.

Heat over flame until paraffin melts.

Wash in xylol for a few minutes to dissolve paraffin.

Wash in absolute alcohol three minutes.

Wash in 95% alcohol three minutes.

Wash in distilled water three minutes.

Stain in the hæmatoxylin solution fifteen to thirty minutes.

Rinse in distilled water.

Wash in acid alcohol until very little reddish-brown stain is given off.

Wash in tap water until sections become blue.

Rinse in distilled water.

Double stain in

Eosin solution.

Van Gieson's stain.

Stain about five minutes.

Stain twenty to thirty seconds.

Rinse in distilled water.

Rinse in distilled water.

Transfer to 95% alcohol.

Transfer to 95% alcohol.

Absolute alcohol for five minutes.

Paraffin sections are cleared in oil of bergamot.

Celloidin sections are cleared in Carbol-xylol.

Wash in xylol.

Mount on a clean slide, add a drop of Canada balsam, and cover with a cover-glass.

Mount in a drop of Canada balsam.

Hæmatoxylin and eosin stained preparations should show purplish-blue nuclei. The protoplasm of cells, the red-blood cells, and all other elements of the tissue a light red hue.

Hæmatoxylin and Van Gieson's solution stained sections should show greenish blue nuclei; fibrous connective tissue, red; blood cells, yellow; the protoplasm of cells, a yellowish color. These stains may be used on tissues hardened after any one of the three methods suggested in the first article of this series.

(To be Continued.)

Agar-Agar. The Preservation of Culture Media.

In spite of the various methods published from time to time for making agar, it cannot be denied that it is still a process dreaded by the average bacteriologist, and with good reason. In almost all laboratories the tedious methods taught in Europe are still adhered to, the result being an infinite amount of labor wasted, and often a very poor quality of agar produced. Three years ago, after several experiments in an attempt to lessen the labor of the process, I hit on the following plan, which I have used and taught ever since with the best results. The only drawback to the plan is that it requires an autoclave, but as this piece of apparatus is now found in all well appointed laboratories, it can hardly be considered a great disadvantage. To make one liter of agar-agar take

- A. Dried peptone (1%), 10 grams.
Common salt (.5%), 5 grams.
Liebig ext. (.5%), 5 grams.
Water, 500 cc.
Boil for three minutes and neutralize.
- B. Agar-agar (1.2%), 12 grams.
Water, 500 cc.

Chop the agar and put into autoclave. Run autoclave up to two atmospheres of pressure, giving 121.4° C. of heat. As soon as this pressure is reached, turn out the flame, and allow the autoclave to cool until below 100° C. before opening. The two solutions A and B are then mixed, cooled to 60° C., the whites of two eggs beaten in 50 cc. of water added, well stirred in, and the whole then boiled and filtered through paper.

The whole process requires only an hour and a quarter to an hour and a half, and the result is a most excellent jelly. Instead of the white of egg, blood serum may be used, which seems to add also to the nutritive value of the medium. Agar made with meat extract will often form a precipitate during the sterilization, which is objectionable if one wishes to use it in the pouring of petri dishes, or the making of Esmarch's roll-tubes.

To make an absolutely and permanently clear agar, fresh meat should be used as follows:

To make one liter, take

- A. Chopped meat, 500 grams.
Water, 500 cc.
Mix and place in cool place over night, then strain through towel.
- B. Agar-agar (1.2%), 12 grams.
Water, 500cc.

Put in autoclave, run up to two atmospheres of pressure, put out flame, and

allow to cool until below 100° C. before opening. Let the solution of agar cool still further to about 75° C., and then mix A and B, add (1%) 10 grams dried peptone and (.5%) 5 grams common salt, bring to a boil for about three minutes, neutralize and filter. The product is an absolutely clear jelly, which never forms any precipitate. The whole process, with the exception of the time the meat is steeping, requires only about one hour and a half. In both the above methods of making agar, the filtration is very quick—from ten to twelve minutes for the liter. I never use a hot-water funnel, but wet the filter paper with boiling water immediately before pouring in the agar. In the process with fresh meat the clarification is effected by the coagulation of the albumen in the meat water, hence solution B must not be added to A until cool enough to avoid coagulation. In general the fresh meat is to be recommended, and the process is easier than with the meat extract, though the latter has the advantage of cheapness, and convenience, since the meat extract can always be kept on hand, and the time lost in soaking the fresh meat is saved.

The two processes above given have been thoroughly tried by myself and others, and can be confidently recommended as being the quickest and simplest methods yet devised for the making of this most necessary culture medium, while the result is all that could be desired.

Before closing, let me advise a simple, cheap, and satisfactory method of preserving culture media, for which I am indebted to Messrs. Kanthack and Drysdale. It is the use of tin-foil over the mouth of the tube. It is applied as soon as the tubes are filled, the cotton plug being pushed in, and any excess of cotton cut off. The tubes can then be sterilized in the usual way, the tin-foil undergoing sterilization at the same time. The covering is not, of course, absolutely air-tight, but very little evaporation can take place, and I have kept media for seven months in perfectly good condition by this method. If desired the tubes can be put into a large museum jar with perfect safety after being capped in the above manner, and preserved thus indefinitely.

MAZYCK P. RAVENEL, M. D.

Bacteriologist to the State Live Stock Sanitary Board of Pennsylvania; Instructor in Bacteriology, Veterinary Department, University of Pennsylvania.

Please do not overlook the blank on page vii. Secretaries of societies kindly send full lists.

The Glandular Stomach of Birds.

In his "Comparative Anatomy and Physiology of Vertebrates," vol. 2, page 161, Prof. Owen says of this organ:

"In the majority of birds the gastric follicles are simple, having no internal cells, dilated fundus, or contracted neck; but from their blind extremity proceed with a uniform diameter to their internal orifice. This form obtains in the zoöphagus and omnivorous birds. In the dove tribe the follicles are of a conical shape; in the goose and turkey they present internal loculi; in the ostrich and rhea these loculi are so developed that each gland forms a racemose group of follicles, terminating in a common aperture in the proventriculus."

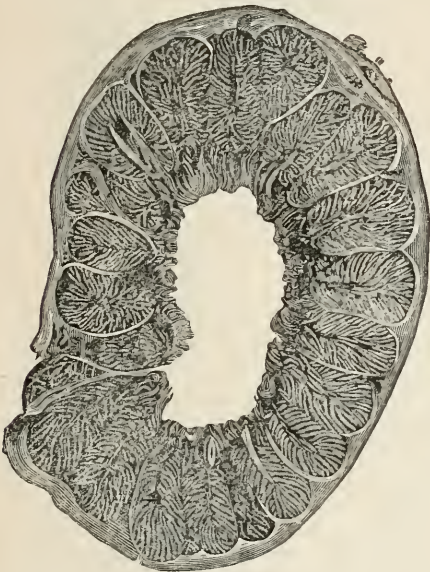

Fig. 1.

I had supposed until a little more than a year ago that the above statements were correct. At that time I had set some students to sectioning for the microscope the glandular stomach of a meadow lark. When ready they called on me for an explanation of the structure that was so different from what they had been expecting to find. Fig. 1, taken from one of the slides made at that time, will show fairly well what was seen at that time under low power.

To explain the figure a little in detail, the outside consists of the usual three coats: serous, muscular, and submucous, not differentiated in the figure. Inside the submucous are a series of plumose glands, each consisting of a series of tubuli, or rather acinic, for instead of being simple tubes, each tube has a lining of short columnar cells with

a nucleus near the center, like the gastric tubules in the human stomach. These lie at different angles to a common duct in the center of the plume, this duct opening into the interior of the organ. This is contrary to the first

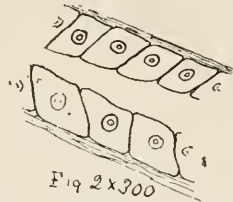

Fig 2 x 300

two of Prof. Owen's statements: "Simple and having no internal cells." Figure 2 shows a camera lucida drawing of seven cells in a tubule from the glandular stomach of a sparrow hawk, where they were slightly separated, magnified 300 diameters. The cells are bounded on the basal side here by the connective tissue forming the framework of the whole gland.

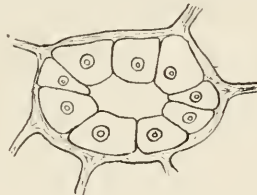

Fig 3 x 300

Figure 3 gives a cross section of one of the tubules in the plumose gland from the same bird, the sparrow hawk, also a camera lucida drawing. The spurs around the sides of the acinus are where the wall of this is joined by walls of adjoining acini.

Inside the plumose glands are a set of short tubular glands, varying some in length, but usually not more than a fourth the length of the racemose glands, each tube an independent gland which opens direct into the interior of the organ. These glands were lined with cells, or rather are a layer of cells lining the tube, the wall of the tube being connective tissue of the same kind as the walls of the acini of the plumose glands, but the cells are somewhat different.

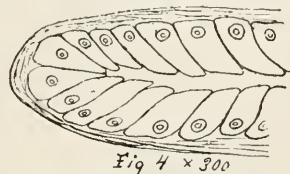

Fig 4 x 300

This is shown in Fig. 4, where the outer or blind end of one of the tubular glands is shown. These cells are more elongated

than those of the plumose glands, and the nuclei are in or near the base of the cells. Thinking that what I found in the meadow lark might not be true of other birds, quite a number were examined, representing four different orders which embraced quite a variety of food habits. Of Passeres, meadow lark, English sparrow, blue jay, crow and Tennessee warbler were studied. Two of Picaridae were taken, the red-headed woodpecker and chimney-swift. In Gallmar, the domestic chicken, and in Raptores the sparrowhawk were examined. In all these, the structure was identical, consisting of a series of plumose glands, each with a large number of tubular acini, and around the duct of these glands a series of tubular glands. In the small birds, these glands were set nearly at right angles to the organ, but in the larger birds, they were set obliquely.

As to the nature of these different glands, I am of the opinion that the plumose glands are peptic and the tubular are mucous. If any one will take the trouble to prepare sections of this organ in any bird, say of the size of the blue jay, as that is the most convenient size for study, and compare the cells of the plumose glands with the cells from the stomach of a rabbit or cat, or with the pictures of the peptic cells of the human stomach, one will see the resemblance. The cells of the tubular glands bear a close resemblance also to the mucous cells of the same organs. In order to see these properly, they should be double-stained with picro-carmin or haematoxylin and borax carmin.

G. H. FRENCH.

Carbondale, Ill.

APPARATUS.

Thermo-regulated Waterbaths for the Bacteriological Laboratory.

There is, perhaps, a no more useful piece of apparatus in a general bacteriological laboratory than a suitable thermo-regulated water bath. The uses to which it may be advantageously put are so numerous that after the habit of using it is established it soon becomes almost indispensable. Wiesnegg anticipated its value and placed upon the market his bain-marie which has met with unquestioned favor. However, its usefulness, on account of its form and size, is somewhat restricted. In order to extend the utility of the principle involved in this apparatus, I have had, by way of experiment, two water baths or tanks constructed and permanently fitted with thermostats and thermom-

eters. They have been in use for nearly a year and have proven to be so satisfactory that a brief note concerning them may be of general interest. Their shape or size should not be taken into serious consideration, for they are flexible features which can easily be adapted to individual needs or requirements. The emphasis should be placed rather on the assistance they render in the saving of time and in the securing of uniform results. In laboratories where instruction is given such assistance is much appreciated by both students and instructors.

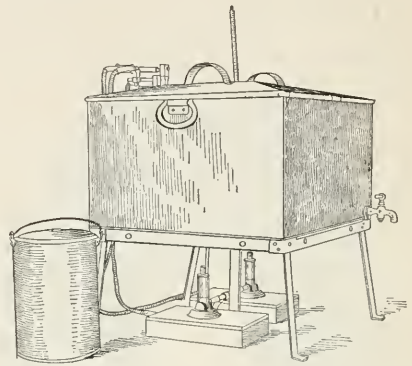

Fig. 1.

The larger water bath (Fig. 1) to which a thermostat was connected is of special value in macerating meat at a high (60-65° C.) temperature for making culture media. It can also be used for a variety of other purposes, such, for example, as sterilizing liquid blood serum or by a class of laboratory students in determining the approximate thermal death points of different bacteria. It consists of a rectangular copper tank 45x50x25 centimeters. It is divided into two apartments, each of which has a separate cover and perforated false bottom. The partition consists simply of a top crosspiece which is about four centimeters wide. Near its center is a round opening two centimeters in diameter for a thermometer, which is protected by a perforated copper tube extending to and soldered to the bottom of the tank. Near the end of the crosspiece, or close to the side of the tank, there is a second and similar opening and shield for a thermostat. There is a faucet for drawing off the water. The tank stands on an iron quadruped. For heating it has been found desirable to use two burners, one under the middle of each side or apartment, the burners being connected by means of a T or Y tube to the gas tube leading from the regulator.

The smaller water bath (Fig. 2) was made for the use of individual (research) students. It is cylindrical in form, twenty-five centimeters high and of about the same diameter. On one side there is a semicircular projection forming a chamber for the thermostat. This is separated from the main tank by

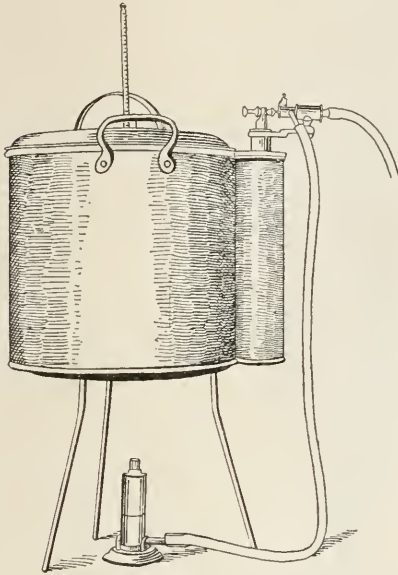

Fig. 2.

means of several narrow strips of copper soldered at each side. The tank is provided, like the larger one, with a perforated false bottom. The cover has an opening for a thermometer. An apparatus of this size makes an admirable milk pasteurizer. It is not expensive and when properly set up requires comparatively little time to operate it.

The Friedberg burner has been found to be very satisfactory for these baths, as they possess to an unusual degree, when properly adjusted, the desirable quality of maintaining a very small flame without striking back. The Roux thermostat seems to be the best regulator for this particular purpose. It is constructed out of metal and consequently it is not easily broken. It is readily adjusted and quite as sensitive as the ordinary spirit or mercury thermo-regulators. VERANUS A. MOORE.

New York State Veterinary College,
Cornell University, Ithaca, N. Y.

A Cabinet for Paraffin Sections.

In my classes in embryology, where each student is required to section and study several embryos, I have

experienced considerable annoyance from the accumulation of paraffin sections which could not be mounted at the time they were cut. In conference with



Fig. 1.

our college carpenter, a cabinet for the temporary storing of these sections was devised which has been found to be very convenient, both in embryology and histology. It fills three conditions, compactness, freedom from dust, and renders it impossible to pile up sheets of sections.

I give herewith a description, hoping that it may be suggestive, if not directly available in its present form, to those who have had similar difficulties.

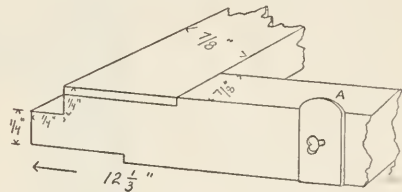

Fig. 2.

It is a box 27 1/4 inches by 12 1/3 inches by 3/4 inches wide, outside measurements, and is made of one-half inch basswood and picture backing. The end is closed with a closely fitting door opening downward. There are twelve trays constructed as shown in detail drawings.

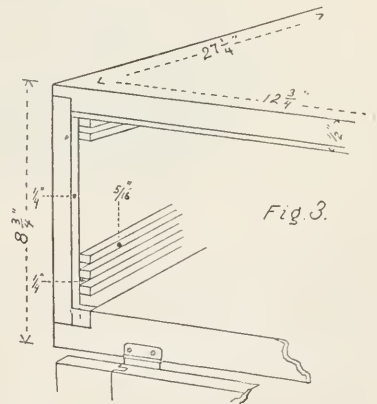
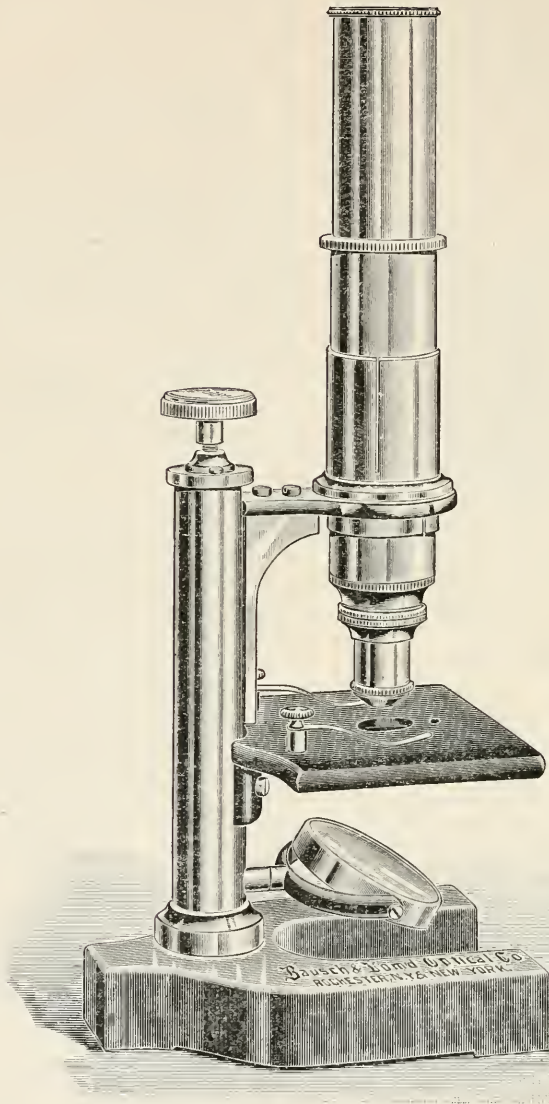

Fig. 3.

The sides are made of one-half inch stuff grooved one-fourth inch deep to receive edges of trays. The space be-



tween the grooves is five-sixteenths inch (see Fig. 3). There are twelve of these guides which support the trays. Screw-eyes are attached to each tray to serve as pulls (Fig. 2, "A").

All parts are glued together. There has been no warping during the three years which it has been in use.

A. D. MORRILL.

Hamilton College, Clinton, N. Y.

A New Microscope Stand.

With the increased use of the microscope in high schools and in public schools generally, there has been a general expression indicating the desire for simpler and yet serviceable instruments. Simplicity of construction in order that the instruments may be durable in the hands of inexperienced students, and cheapness because of the inadequacy of

appropriations made for apparatus, are the general requirements.

In conformity with this tendency, I have endeavored to construct an instrument which shall fulfill these conditions and still be a scientific instrument and not a toy, a problem rather more difficult of solution than might be supposed.

A choice must be made between two types of instruments, one having the coarse and fine adjustment by means of a good rack and pinion, the other having a sliding-tube coarse adjustment and fine adjustment by micrometer screw. I designed an instrument corresponding to the first form last year for the examination of meats and other food stuffs, and a description of the second form is the purpose of this paper.

The qualities of a perfect fine adjustment are delicacy, rigidity, and permanency. The form of construction now followed in the continental types of microscopes is generally accepted as the best, but its use in any simple instrument is precluded on account of its considerable cost. I have succeeded in devising a form of fine adjustment which has proven an excellent substitute. The instrument to which I have applied it has a small japanned iron base, the pillar and arm is a single brass rod, seven-eighths of an inch in diameter, in the upper half of which is recessed a V-way with a T cross-cut to which the arm is fitted. This combines extreme rigidity with compactness. Recessed into the lower end of the pillar is a spring which forces the arm upward against a micrometer screw which is attached to the upper extremity of the rod. In the lower end of the screw a hardened steel pin is recessed so that eccentricity of the screw cannot possibly be conveyed to the arm. Attached to the arm is a plate which receives the sleeve tube in which the body tube carrying the eyepiece and objective slides. The body tube is of standard size and of a fixed length of 160.0 mm. The stage is fastened to the pillar rigidly, is of liberal proportions, and is provided with a revolving diaphragm. The dimensions of the instrument are as follows: Total length with objective and eyepieces attached ready for use, 11 inches; stage, $3\frac{3}{4}$ by $3\frac{3}{4}$ inches. The outside dimensions of the case are 11 inches high, $4\frac{1}{4}$ inches wide, $5\frac{1}{2}$ inches deep. The portability and permanent working qualities of this instrument make it an ideal travelling microscope, while its simplicity of construction, and the fact that it possesses a good working coarse and fine adjustment fit it for school use.

EDWARD BAUSCH.

Rochester, N. Y., June 10, 1898.

Hints on the Construction of a Tow Net.

A tow net for the collection of pelagic organisms is an essential part of the equipment of the biological laboratory, yet few possess one of the most convenient and practical forms. Such a net serves as the most effective and rapid

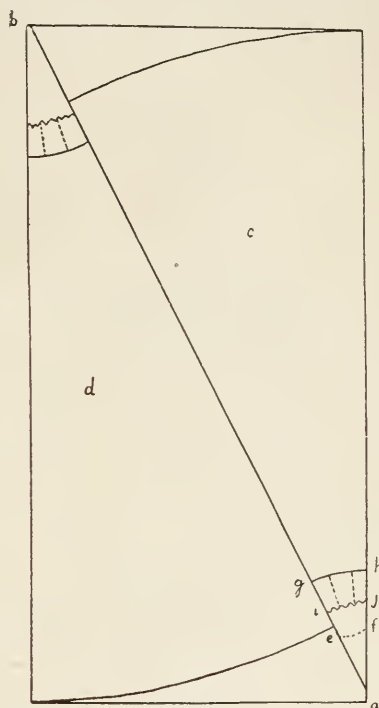

Fig. 1.

method of collecting the pelagic life of marine and fresh water, and is conveniently operated by drawing it behind a boat, or by lowering it to the desired depth and then drawing it to the surface of the water. The organisms in the water of shallow pools or in the midst of vegetation may be secured by pumping or dipping the water into the net. In salt water the tow net secures the pelagic algae and diatoms, the adult pelagic invertebrates, and the larval stages of many others, and also the eggs and fry of many fish. In fresh water the catch usually consists of Entomostraca, Rotifera, Protozoa, Diatoms, Desmids, the smaller algae, and a few insect larvae. Even Hydra may at times be taken in quantity in the deeper waters of shallow ponds and lakes in the spring and early summer, when the plankton is abundant.

The net here described presents no striking features of originality. It is the result of some experience in pelagic collecting, is inexpensive, durable, and so constructed as to facilitate the removal of the catch for preservation. The bag of the net should be made of fine India muslin, or, better still, of Swiss silk bolting cloth. The latter is to be preferred on account of its greater evenness and durability. This bolting cloth comes in twenty-four different weaves, num-

being more than compensated by the greater amount of water strained. The smaller organisms which escape through the silk may be secured by filtering the water through hard-pressed filter paper,

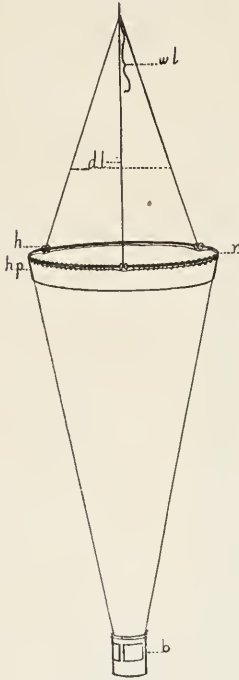

Fig. 2.

bered from 0000 to 20, containing, according to the manufacturer's statement, from 324 to 29,929 meshes per square inch. These cloths may be obtained from dealers in mill supplies. Depour & Co.'s Anchor brand, standard quality, which has been used thus far in plankton work in this country, can be obtained from the American agent, R. P. Charles, 13 South William street, New York city, or from B. F. Gump, 53 South Canal street, Chicago, Ill.

The No. 12 cloth is not so expensive as the finer weaves and serves very well in a tow net. Its meshes are not so fine as to clog quickly and then push aside the most of the water which the net meets. In the same length of haul a net of this silk will catch a great deal more plankton than one made of the finer silks, the greater loss by leakage

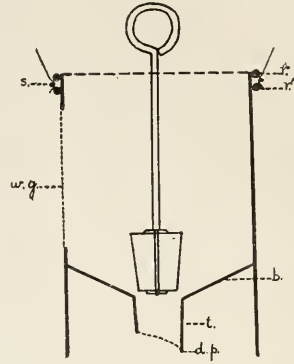

Fig. 3.

No. 575 Schleicher & Schuell being an excellent paper for this purpose. Before cutting out the net, the silk should be boiled in soap-suds, and then pressed, or, better still, put through a mangle, so as to avoid the distortion of the net caused by the shrinkage of the new cloth with use.

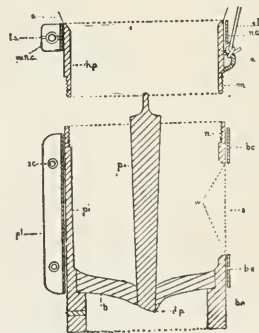

Fig. 4.

Two nets, twelve inches in diameter and of convenient length, can be made from a yard of the silk, which, before shrinking, is forty inches in width. In cutting out the nets, the shrunken cloth should be doubled lengthwise (with the warp) and along a diagonal line passing from "A" to "B," as shown in Fig. 1. As one of the nets "D" must have two seams, an allowance of one-fourth inch must be made for the extra seam. The tops of the nets are marked off by striking arcs across the ends of the cloth with a radius equal to the length of the cloth, and from "A" and "B" as centers. The

cones may then be completed by closing the sides with a French seam. If no bucket is desired at the end of the net, it may be closed by the seam "ef." The condensation and transfer of the catch to a bottle for preservation, is, however, more effectively and quickly accomplished if a bucket is used. The place at which the attachment of the bucket should be made can be indicated by striking the arc "gh," equal in length to one-half of the circumference of the bucket. The tip of the net may then be cut off at "ij" and the silk slit along the dotted lines to allow for the fitting and fastening of the bucket in place.

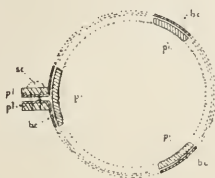

Fig. 5.

The top of the net is finished by sewing on the headpiece (h. p. Fig. 2,) which is made of a doubled strip of butcher's linen, cut bias, and having a heavy cord sewed in the upper margin. The net is fastened to the ring which supports the mouth, by a series of overcast stitches of heavy thread. This ring (r) should be made of No. 5 spring brass wire (American Standard Gauge). At equidistant points upon it are soldered three pairs of hips (h) or wire rings, which serve to hold the draw-lines (d. l.) in place. At the junction of the draw-lines, a short cord serves as a weight-line (w l.), to which a weight can be attached when towing in deep water.

An inexpensive, and at the same time convenient, bucket can be made of sheet copper in the form of a cylinder three inches in height and two inches in diameter. Two light, wire rings (r and n, Fig. 3) are soldered around the upper end of and hold in place between them the string "s" which ties the tip of the net to the bucket.

In the sides of the cylinder are cut three equidistant windows, each one and one-half by one and three-fourth inches, which are closed by brass wire gauze (w. g.) soldered to the edges. Gauze containing 200 meshes per linear inch answers very well for these windows.

The bottom (b) of the bucket is formed by an obtuse truncated cone of copper which meets the sides of the cylinder an inch above its base. At its center is an opening one-half inch in diameter, which is continued in a short tube (t) which reaches almost to the bottom of

the bucket and is obliquely pointed, forming a drip point (d. p.). The opening is closed by a rubber cork whose wire handle projects slightly above the top of the bucket.

A detachable bucket was described by the writer,* which is adopted for use on the plankton net in vertical or oblique hauls. If made of lighter construction, it might well be used upon a tow net. This bucket consists of two parts, a head-piece (h. p. Fig. 4) and the bucket proper. The head-piece bears a net clamp (n. c.) which binds the end of the net (s) to the top of the bucket. The clamp is tightened by means of the thumb screw (t. s.) in the wing (w. n. c.). The lower edge of the head-piece bears threads at "m," which fit corresponding threads on the bucket at "n." The windows (w) shown in cross-section in Fig. 5, are closed with silk (s), held in place by a band-claim (b. c.) which is tightened by screws (s. c.) in the plates (pl. and pl.). The bottom (b) of the bucket is provided with an outlet and drip-point (d. p.). A handled plug (p) closes the opening. The band of silk is fastened onto the body of the bucket and the pillar (pl) between the windows, with King's waterproof cement, and the clamp is then bound against it. This method of closing the windows in the bucket permits the ready renewal of the silk when it becomes worn or clogged. Owing to the weight of this form of bucket, it is advisable to support by three equidistant stay-lines (s. l.), which are fastened in eyes (e) in the head-pieces and thence pass to the hips on the ring at the mouth of the net.

The advantages of the detachable bucket are the freedom from the net, and ease in the subsequent handling of the catch.

CHARLES A. KOFOID.

Illinois Biological Station.

*Bull. Ill. State Lab. Nat. Hist. Vol V, Art. 1, pp. 5-8.

A Simple Urine Sedimentation Apparatus.

The following is a description of an apparatus which is used and described by Charles S. Swan, M. D., of Boston, Mass., for collecting urine sediments. It consists primarily of a piece of glass tubing (T) three-fourths inch inside diameter and three inches in length, which is held firmly between two wooden slips (S) by two rods (R) upon the ends of which threads are cut for the milled head nuts (N,) as shown in the accompanying figure. The rods are

6 inches long and one-eighth inch diameter. The slips (S) are two inches by one inch in size, and have a hole five-eighths inch in diameter bored through the center. The centers of the holes are to correspond with the axils of the tube (T) when the apparatus is set up. Over the hole in the lower slip a heavy piece of blotting paper (P) is placed before the tube (T) is put in position. A base-board (B) five inches by two inches, of the same material as the slips, which are about one-eighth of an inch thick, is fastened securely to the bottom of the apparatus by milled head nuts (N).

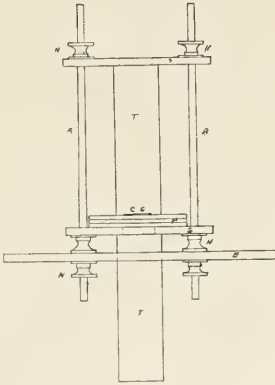

This allows the whole apparatus to be set securely on the edge of a tumbler. If a tube (T') the size of the upper tube (T), the upper end of which is filled with absorbent cotton, is run through the base-board (B) so that the cotton comes in contact with the lower surface of the blotting paper, the filtrate will be carried into the tumbler without wetting the outside of the apparatus. Thoroughly rinse the inside of the apparatus and just before the urine (about 20cc.), which has been previously shaken, is poured into the tube (T) drop into it a clean cover glass, so that it rests flat upon the blotting paper. After pouring in the urine, cover opening to keep out the dust. Upon removing the cover glass after the process is complete, the under side of it (the upper when mounted) will be found to be dirty; this may be cleaned off by placing it upon a drop of water upon a thin piece of paper and carefully moving it about. The results obtained vary with the quality of the urine. Urine with abundant mucus does not work so well; the best results are obtained with thin urines of low density, where it is desirable to search for casts. Although this apparatus helps out in many ways, it does not take the place of the centrifuge which is now so generally used.

ABSTRACTS.

Anatomical Atlas of Tschirch and Oesterle.*

The Anatomischer Atlas of Tschirch and Oesterle is an indispensable guide in every botanical laboratory, not only because of the careful drawings and descriptions of crude drugs, but the excellent account of foods in general will be a great help in the botanical laboratory. No other modern work has given as many careful details of economic plants as this one. It also contains a great deal of information on the development of various parts of the plant used as drugs or food. Lieferung 10 deals with Ergot, *Secale cornutum*, various economic smuts. The seeds of *Lycis Githago*, *Melampyrum arvense*, a full account of the seeds of *Pisum* and *Phaseolus multiflorus*. For the testa the terms palisade epidermis, I-cells, nutrient layer are used. The use and function of the nutrient layer is given. Its function ceases when the seed is ripe. Hyphae of fungi were often noted in the hilar groove, but never in the "tracheid island." The island resists the entrance of fungi. In *Pisum* the water enters through the testa and not the micropyle or hilar groove. An equally full account is given of *Phaseolus multiflorus*. The term strophium is used for the arillate processes at one end of the hilum. The testa, in the wider sense, is made up of palisade epidermis, I-shaped cells followed by parenchyma differentiated into three parts. The inner integument consists of an obliterated single brown wall (Haut). This is followed by the perisperm which may be obliterated or consists of a single row of cells or several in the radicular pouch. The cell-walls are mucilaginous. There are also shorter accounts of *Erym Lens*, *Phaseolus vulgaris*, *Dolichos sinensis*, *Lablab vulgaris*, *Soja hispida*, *Vicia Faba*, *V. sativa*, *Lathyrus sativus*, and *Cicer arietinum*. The remainder of the Lieferung is devoted to amyllum and continued in the twelfth number. All of the more common reserve starches are figured and described. Lieferung 12 is devoted to mace, seed of flax, *Rhiz. valerianae*, *Folia coca*, *Herb matae*. A work of this kind has long been needed and the writers are doing botanical science a great service.

L. H. PAMMEL.

Iowa State College of Agriculture and
Mechanic Arts.

* Anatomischer Atlas der Pharmakognosie und Nahrungsmittelkunde, Leipzig, 266. Lieferung 1-12.

The Construction of Achromatic Doublets and Triplets.

E. M. Nelson, in his presidential address to the Royal Microscopical Society (Journal Royal Microscopical Society, 1898, part 2, pp. 156-169), explained, with several examples, the methods of calculating achromatic doublets and triplets, including the kind of glass to be used, and the radii and thickness of the elements. The paper is of the utmost interest to microscopists, and Mr. Nelson, by his admirable system of illustration by the numerous examples, has made it comprehensible to even those who have no great knowledge of mathematics, and all must hope for an extension of the subject to the construction of apochromatics.

P. E. B. JOURDAIN.

Derbyshire, Eng.

Diagnosis and Description of Bacteria.*

In order to secure uniformity in the description and differentiation of species of bacteria a committee of American bacteriologists, consisting of J. George Adami, A. C. Abbott, T. M. Cheesman, George W. Fuller, W. T. Sedgick, Charles Smart, Theobald Smith and W. H. Welch was appointed. In the preface, Dr. Smart gives the history in connection with the movement of the American Public Health Association to adopt some uniform methods in the description and differentiation of species of bacteria. The paper should be in the hand of every bacteriologist. It would be well to reprint the pamphlet and put it in book form. The pamphlet includes the standard charts for bacterial diagnosis compiled by Dr. Cheesman. These are most conveniently arranged and add not a little to the value of the pamphlet.

L. H. PAMMEL.

*Procedures Recommended for the Study of Bacteria, with Special Reference to Greater Uniformity in the Description and Differentiation of Species. Rep. Comm. of Am. Bacteriologists to the comm. on the pollution of water supplies, of the Am. Public Health Association, Philadelphia meeting, 1897; separate, Concord, Mass., 47; 5 charts. 1898.

The Centration of the Electric Arc in Photo-Micrography.

J. E. Barnard and T. A. B. Carver (Journal Royal Microscopical Society, 1898, part 2, pp. 170-173), found that, with an automatic lamp, fluctuations in the intensity of the light and diffraction phenomena and shadows were unavoidable. That the latter were due to decenteration of the light was proved by projection of the image onto a lined

screen, by means of which movement of the image could be observed. These defects of the automatic lamp, together with the fact that inconstancy of the length of the arc is, a priori, unavoidable in that form, led Messrs. Barnard and Carver to design a hand-feed lamp in which the relative positions of the carbons, held in V-clamps which slide upon two rigid vertical rods, are varied by a right and left-handed screw, and the position of the pair together by another screw. The indicator of centrality consists of a small, cylindrical, metal pin-hole camera, mounted on a universal joint, so that an image of the arc is cast upon a ground glass screen provided with reference lines. The question of inclination of the carbons to the vertical was investigated by means of an apparatus giving revolution of the arc about a horizontal axis passing through itself; and the "critical inclination"—the greatest at which none of the light from the crater is cut off by the negative carbon—was found to be about twenty-seven degrees.

P. E. B. JOURDAIN.

Derbyshire, Eng.

Collection of Pond Life on Photographic Plates.*

While examining some ordinary photographic plates under the microscope, Mr. Wallace Goold Levison, S. B., found an interesting way of catching and holding minute organisms for examination under the microscope. He found numbers of these forms adhering to gelatin coated photographic plates after the plates had been in the water the usual time allowed for washing them after coming out of the hypo solution. The number of forms varied with the length of time the plates were in the water. By placing the plates in a box used for washing the hypo from the plates and letting the city water run through it, he collected on them a few large diatoms, many smaller ones, and a large number of small active forms. When the film had become soft after being in the water several days, vorticellae and other infusoria appeared anchored to the film. These forms appeared although this box was in a dark place and was frequently used for washing the hyposulphite solution from the plates, and for washing acid solutions from metal plates. For convenience in examination, he cut the plates into small pieces, so that he could put them in a cell, film side up, and examine them with a thin layer of water over them. His ex-

*Preliminary note read before the New York Microscopical Society.

perience leads him to believe that these plates can be successfully used to collect pond life by leaving them a greater or less time submerged in the pond. It first occurred to him that the gelatin might attract these forms for food purposes only, but this would hardly answer for the appearance of the larger forms, even though he tried to collect them on other surfaces with little success.

Micro-Organisms of Industrial Fermentations.*

Jorgensen's work on micro-organisms has not only won for itself a place in the Danish language, but the English and German as well. The fact that a revised third edition appeared in 1893, and the fourth in 1898, speaks well for the work. The subject matter receives the same general treatment as in former editions. The alcoholic ferments receive special consideration, especially the true yeasts with endogenous spores; also other yeasts, bacteria, and moulds injurious to the process of brewing are treated. The last chapter deals with the practical application of the question.

L. H. PAMMEL.

*Die Mikro-organismen der Gahrungsin-
dustrie Vierte, neubearbeitete und vermehrte
Auflage Berlin, 3+349. 1898.

Migula's System of Bacteria.*

The Migula book is the most important which made its appearance during the past year, and, regardless of the opinions expressed, it is certain to become classical. A short review cannot do justice to subject matter which has not only been well selected, but the author has thoroughly searched the literature of European works, which will make it invaluable as a reference work. American literature has been somewhat neglected. The book is divided into the three parts: I, Historical development, page 50; II, Morphology and Development, pages 50 to 237; III, Biological Characters, pages 242 to 361. In the chapter on pleomorphism, the author agrees with Winogradsky that pleomorphism, under cultural conditions, does not occur in bacteria, but in closing the chapter he discusses the variability of different organisms and states that there are few bacteria which are of one form (Einformig). The author refers here to varia-

bility of the organism such as occurs in higher plants. The Asiatic cholera spirillum may be taken as an excellent illustration, as showing how variable the species is as to form. He adopts essentially the classification elaborated by him in Engler and Prantl Pflanzenfamilien.

He refers to *Bacillus secales* as the Burrill corn disease. Dr. Moore and Theobald Smith have well shown that this organism is identical with the *Bacillus cloaceae*.

L. H. PAMMEL.

Locating Objects Under the Microscope by the Points of a Compass-Dial or of a Clock-Face.*

This obvious expedient is of course known to many; but according to the writer's observation it is adequately used by few if any. It is certainly capable of greatly increased usefulness. Anyone who has seen, as the writer has witnessed many times, an experienced and competent microscopist search two or three hours for some special object known to be somewhere amidst the confusing abundance on a large mount, and then go off to bed (toward morning) without finding it, will realize the convenience and importance of having some ever-present means of knowing where to look and how to record the location.

For locating a certain small object among a large number strewn over a slide, or a structural point in a large section, for instance, for the sake of being able to find it again or to tell someone else where to find it, the Maltwood finder leaves little to be desired in accuracy; as the object can be directly located in one of the squares of 1-50th inch, and by recording the position in the square by tenths, readily estimated by the eye, its location can be almost infallibly determined and recorded to 1-500 inch. The records are entered in double lines of figures, as

31.6

18.4

the upper line giving the horizontal and the lower line the vertical reading. But this method, though on the whole the best for fine work, requires a special piece of apparatus which is not incapable of being broken in careless hands, and therefore falls far short of being universally applicable.

The rough expedient of drawing a circle on the cover-glass, around the object, is also useful in some cases; though much more troublesome and less precise, and wholly inapplicable when

* System der Bakterien. Handbuch der Morphologie, Entwicklungsgeschichte und Systematik der Bakterien, Jena 1: 368, 6 pl. 1897..

*From Report of the American Postal Microscopical Club, Troy, N. Y., 1898.

many objects are to be designated on the same slide.

By imagining a compass dial to be centered upon the cover-glass, with North at the top, the location of any object can be stated off-hand and instantaneously, and with definiteness enough for all low and medium powers. Everything in the general direction from the center to the top would be North (recorded as "N."); and by glancing over that portion of the slide any object tolerably easy to recognize can be promptly found under any power up to two-thirds, and with a little adroit manipulation up to one-fifth. In cases of special difficulty, and often with higher objectives, a medium power should be used as a finder, as in other methods. By designating the distance from the center by tenths (estimated) of the radius, further definiteness is and should be attained with no appreciable trouble. Thus an object stated to be at "N. 5" would be half-way from center to top; at "E. 9" would be at the right and near the circumference; and at "N. E. 3" would be on a radius midway between the two former and about one-third of the way out. This locates the radius near which the object lies, to about one-eighth of the circumference, or 45°; which is good for low powers, or for points near the center, but not precise enough for high powers working near the circumference of large mounts. Of course these angles can be subdivided by combining the letters to make 16 points of 22½° as "W. N. W.;" but few persons could do this without some possibility of confusion.

The clock-face, a somewhat more familiar object, gives greater precision by dividing the circumference into 12 segments of 30° each; the principle is the same, the directions being given by the hour figures, and the distances of radius by decimals; a system successfully used in designating instantly the location of the bullet holes made in target shooting, except that there the radial distances are given by concentric circles. Here the top becomes 12, the bottom 6, and intermediate points by the familiar directions of the clock face. Thus the "3,9" location would be at 3 o'clock, to the direct right and nine-tenths out, or identical with the "E.9" of the compass method. By the clock method the hour spaces can be readily halved by the eye, giving 24 segments of only 15° each. It might be seen that an object was at the right of 12, but not as far as 1, giving 12½; while the pointer in the cut would, without the aid of the figures, be recognized as about midway between 12 and 3 o'clock, corresponding with "N. E." of the compass; so that "1½, 3" here would be identical with "N. E. 3" of the other. With a very

little practice one will recognize the 4 and 5 o'clock directions almost as accurately as the 3 or 6; and the location of dozens of small shells, scales, or other objects can be recorded almost as fast as the numbers can be written. Experts would omit the "." after "N," etc. The contraction "o.c." may be added to the record, to indicate the clock method, as "3,9 o.c.;" but it is unnecessary, as these entries have no likeness to the double lines of the Maltwood system.

If instrumental precision be desired, it can be secured by carefully centering the cover-glass around the optical axis of the microscope, and then, with the goniometer ocular or with the graduations of the concentric revolving stage, measuring from this center the angular distance of the object above or below the longitudinal axis of the slide; and then measuring with the ocular micrometer the linear distance from the center of revolution. Thus an object at the right and 60° below the axis would be a 5 o'clock, one at the left and 30° above the axis would be a 10 o'clock, while the minute hand, being about 47° above the right, would be about a half-past one, as already seen. By this means the object can be easily located within a single degree; but that is seldom, if ever, necessary, as sufficient accuracy for the cases to which this method is applicable can be gained, almost automatically after a little practice, by comparison with the picture of the dial "in the mind's eye."

R. H. WARD.

Troy, N. Y.

New Form of Photo-Micrographic Camera and Condensing System.

E. B. Stringer (Journal Royal Microscopical Society, 1898, pp. 174-179) brought before the Royal Microscopical Society a form of apparatus for high-power photomicrography which possesses novel features, and is very convenient in use. The rear part of the camera extends by means of sliding brass tubes, so that both when at its shortest and longest focus there is no projecting baseboard. A door is provided at the side of the camera for focusing the image on a white card in situ, and the whole camera can be drawn backwards for looking down the microscope when in position, or for screen projection.

Mr. Stringer avoids vibration by clamping down nothing, and by supporting the apparatus on layers of cork and felt. The microscope has a tripod support, the feet of which pass through holes in a triangular brass adjusting plate onto a cloth-covered board beneath. The focusing is by an endless

cord passing over pulleys, the size of which can be changed for high or low-power work.

The condensing system, oxy-hydrogen jet (Zirconium light) and sheet-iron lanterns are carried on an optical bench, made square, instead of prismatic in section; and the condenser, computed by Mr. E. M. Nelson, is four and one-fourth inches in diameter, perfectly achromatised and almost perfectly aplanatic. The light from the jet is first parallelised by the doublet condenser, which consists of two plano-convex lenses having their plane sides turned towards the radiant, the one next the radiant being a quarter of an inch less in diameter than the other, and the focal length of the combination being two and three-fourth inches, taking up an angle of seventy degrees. The parallel beam passes across an interval of about ten inches, through a screen or light-filter, and enters the plano-convex lens of four and one-fourth inches diameter (having its convexity turned the other way to minimise aberrations, by which it is converted into a convergent cone. This, after passing through water in the chamber between the lenses, is again parallelised by the much smaller plano-concave lens, and emerges from it as a slightly divergent pencil rather less than an inch in diameter. The plano-concave lens is of highly dispersive glass, and perfectly achromatises the whole system. The whole system is provided with centering screws, and an iris in front of the combination next the light can be adjusted to shut off the surplus light that is reflected from the interior of the microscope tube.

P. E. B. JOURDAIN.

Derbyshire, Eng.

NEWS AND NOTES.

Personals, news items, notices of meetings of societies, conventions, etc., will be received up to the twenty-second of the month preceding issue.

Reports of three meetings of the New Jersey State Microscopical Society have been received.

At their meeting of February 28, 1898, Mr. F. B. Kilmer, after calling attention to the advance in ideas as to the necessity of surgical cleanliness, explained some of the commercial means (heat, pressure, chemicals) of producing anti-septic dressings, etc., showed on the screen pictures of some of the appliances for obtaining these results, and also some of the more common germs at the destruction of which he is aiming.

Their meeting of March 28th, was given over to the Botanical Section. Dr. B. D.

Halsted and Messrs F. H. Blodgett and J. A. Kelsey presented papers.

By means of a series of charts, Dr. Halsted explained the development of exogenous stems from the early meristematic condition of the vegetative point to that of the mature wood tissue.

Mr. Blodgett gave the results of his study on the development of Erythronium from the seed to the mature plant; also the development of new plants by means of runners.

Mr. Kelsey called attention to the appearance in this country for the first time in 1896 of the asparagus rust (*Puccinia asparagi*, D. C.) and the damage which it is likely to do. It has been known in Europe for a century. He suggests Bordeau mixture as a preventative, and also refers to the parasite, *Darlucaum tilum*, Cast., as presenting a possible solution of the problem, as it attacks the uredo form of the rust.

At their meeting of April 25th, representatives of J. B. Colt & Co., of New York city, exhibited their natural color lantern and explained the processes by which they obtain colored pictures by means of violet blue, red, and green screens.

Publications Received for the Journal Library.

No. 13, Band XXIII of the Centralblatt fuer Bakteriologie, Parasitenkunde u. Infektionskrankheiten, Nos. 3 and 4 of Vol VII of the Journal of Comparative Neurology. The Bulletin of the Ohio Hospital for Epileptics, and the Iowa Health Bulletin, Vol. XI, No. 7.

From the U. S. Department of Agriculture: "Standard Varieties of Chickens, Fowls: Care and Feeding, Ducks and Geese;" "The Country Slaughterhouse as a Factor in the Spreading of Disease;" also the report of the Chief of the Bureau of Animal Industry. We acknowledge receipt of Bulletin No. 143, N. Y. Expt. Sta., on the Cottonwood Leaf Beetle.

We are also indebted to Dr. A. W. Bitting for his paper, "A New Photomicrographic Apparatus," from the Proceedings of the Indiana Academy of Science; to Fred'k D. Chester for his paper, "A Preliminary Arrangement of the Species of the Germs Bacterium," from the Ninth Annual Report of the Delaware College Agricultural Experiment Station, and to Dr. A. Mansfield Holmes for the following separate: "The Study of the Blood in Tuberculosis," Journal of the American Medical Association, October 23, 1897; "A Clinical Study of Tuberculosis Cases Treated with the New Antiseptic Serum T. R.," from the same Journal of Feb. 5, 1898.

Journal of Applied Microscopy.

VOLUME I.

JULY, 1898.

NUMBER 7

The Use of the Microscope in the Detection of Adulterants in Powdered Drugs.

The time is within the recollection of many of the microscopists of to-day when the instrument which they now regard as an essential equipment of a laboratory, was little more than a toy, even in the hands of a scientist. Those of us who are able to look back upon that time wonder why the compound microscope was not more fully appreciated. We cannot understand the skepticism which prevailed as to its practical value, nor do we understand why it made such slow progress in uprooting the prejudice as to the accuracy of its revelations. To-day the microscope has come more and more into use for what may be termed practical work. Not least among its practical applications is that of the detection of adulterations, and among the various branches of this latter department there has been manifested of recent years special interest in the detection of adulterants in powdered vegetable drugs. It need not be said that this is not an easy task, especially if the adulterant be of a character similar in structure to that of the genuine article. If the product of a powdered leaf, for example, be adulterated with the product of another leaf, the chances for the recognition of the adulterant would be in a vastly less degree probable than if the adulterant were the product of a wood or seed, for the elements common to each of these are quite different and could easily be seen under the proper magnification. In either case, however, it becomes necessary for the microscopist, if he would detect such adulterant, to become familiar with the microscopical characteristics of the drug which he is to examine and to have a knowledge of the different elements which it contains. These can only be understood by careful microscopical examination, by taking transverse, longitudinal, and tangential, or ra-

dial sections, as the case may be, and by this means to locate and become familiar with the structural anatomy of the part under consideration. It goes without saying that each particular drug has its own characteristic structure, and, fortunately for the microscopist, the elements composing this structure are not generally destroyed beyond recognition during the process of pulverization, even though this pulverization reduces the substance to the condition known as an impalpable powder. If it is in a powder of this latter class, considerable difficulty is experienced as compared with that of coarser powders, yet even in them the elements exist and, under the influence of microchemical reagents, they exist in a recognizable condition.

During the past two or three years the writer has endeavored to enter this field of research and has attempted to show that it is possible to detect such adulterants as are liable to occur in certain medicinal powders. No attempt will be made in the present article to give the result of this work in detail, but the aim is merely to call attention, to it, to interest other lovers of the microscope, and to bring about if possible a co-operation in the field so interesting from a practical standpoint.

One of the first studies made in this line of research by the author was the study of *Virbunum opulus* and *Virbunum prunifolium* in the state of powder. It was found by examination of the longitudinal and transverse sections that the two barks differed in that the bark of the *opulus* contained no stone cells, and in the *prunifolium* stone cells were present in great numbers. Therefore, the following procedure for the examination of the different powders was found all that was necessary to identify and distinguish them. A few particles of the

well mixed powders were placed in a porcelain capsule containing a mixture of alcohol, glycerine, and water, and after two hours' maceration the examination was commenced, when the nature of the elements enclosed in the cells was observed. To render more prominent the form of the various elements and fragments the particles were boiled with alkaline water. Those portions of the structure partially invisible before now became prominent. In the case of *Virbunum prunifolium* it could be clearly seen in the powder that the numerous stone cells can readily be distinguished; as regards the absence of these plainly identifies the bark as distinguished from the other species.

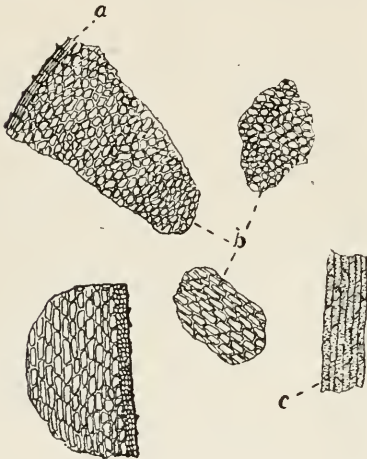

Fig. 1.

Another study on the same line—distinction between *Frangula* and *Cascara* barks—resulted in the following: that *Rhamus frangula* contains no stone cells, while the *R. Californica* and the *R. purshiana* contain a large number of these scattered in large irregular groups below the cork and usually outside the region of bast. The presence or absence of stone cells, therefore, was found to be a method by which powdered *frangula* could be distinguished from *R. purshiana* and *R. Californica*.

Continuing along this line was another investigation which related to the distinction between *Senega* and *Quillaja*, it having been urged that *Quillaja* bark was sometimes used as an adulterant of the former. It was found in this study that there was no difficulty whatever in distinguishing between the powders of *Senega* and *Quillaja*. In the latter bark are found elements not present in *Senega*. The presence of bast fibers, of sclerotic tissue, and the

numerous and easily observed prismatic crystals of calcium oxalate in the *Quillaja* marks this adulterant and betrays its presence, when mixed with *senega* powder. The elements characteristic of these powders are herewith shown.

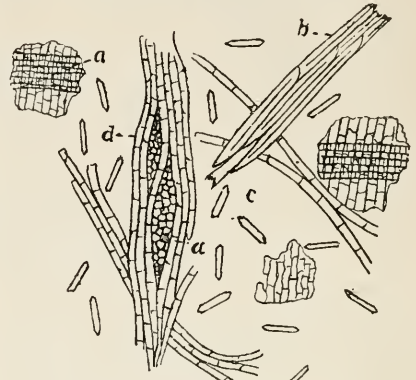

Fig. 2.

As another examination or study in this line of work, a problem was submitted asking for the detection of *Rumex hymenosepalus* in powdered *rhubarb*. This latter kind of adulteration was somewhat new to the writer, and he carefully examined the literature to find where the use of it as an adulterant was first suggested. He found that in "Illustrated New Mexico," fifth edition, 1885, page 3, was a statement of this kind.

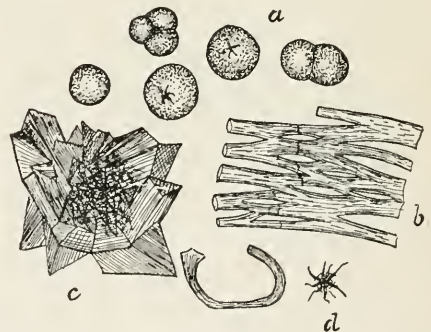

Fig. 3.

Speaking of *canaigre*, it said: "It seemed probable that this root may be used to advantage in place of *rhubarb*, when a more astringent medicine is indicated." It was found upon examination that the characteristic elements of powdered *rhubarb* are the calcium oxalate crystals and massed acicular crystals of chrysophanic acid, and that the adulteration of *rhubarb* with *canaigre* may be detected by its characteristic long starch grains, as represented. Further-

more, it was found that the distinction between these two powders could be made more apparent by the application of a solution of ammonium hydrate. Under the influence of this liquid rhubarb turns a dark brick-red color, canaigre with the same reagent gives a brownish color. To apply the test, carefully place on a glass surface a small amount of the powder and moisten it with a drop or two of ordinary ammonia water. At once the color reaction becomes apparent.

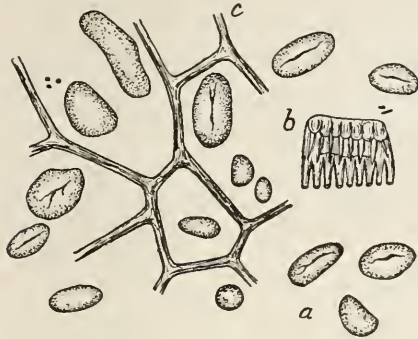

Fig. 4.

Several interesting points have been derived from the examination of powdered senna. It would be impossible in the space devoted to this article to enter upon this subject in detail, but by referring to the "Journal of Pharmacy," Nov. 1896, pages 585 to 588, and June, 1897, pages 298 to 307, the result of this investigation can be seen. One point of interest in connection with this study, that may be mentioned here, is the method found sufficient for the detection of a possible adulterant, chestnut leaves. The latter can be revealed under the lens by the presence of tracheids and pitted cells which compose the midrib of the chestnut leaf and also by the rapidity with which the tannin of the latter leaf reacts by the addition of a drop of a solution of ferric chloride. The directions for the detection of chestnut leaves by this method are as follows: Place half a gram of the number 60 powder in a layer of uniform thickness on a clean glass slide and place this on a piece of clean paper. Drop upon this one drop of a five per cent. solution of ferric chloride. The drop remains for some time in the form of a globule unabsorbed. If senna alone be present the powder as seen through the drop remains comparatively unchanged; if any chestnut leaves be present they will be shown by the particles under the drop in less than thirty seconds, turning a dark blue or black color in the presence

of tannin. A very small percentage of chestnut leaves in senna can thus be detected.

L. E. SAYRE.

School of Pharmacy, University of Kansas, June 25, '98.

Laboratory Tables.

During a recent tour of inspection to many of the biological laboratories of the eastern section of the United States, in search of information regarding laboratory construction and equipment, a question which was almost invariably asked me at each place visited was, "What sort of laboratory table do you use?" No one seemed to be satisfied with his own kind, but wanted something different. While the size of the top, the height from the floor, the position of the drawers, etc., all seemed to be important details, the matter which was most inquired about was the preparation of the top so that it would stand the rough usage to which a laboratory table is necessarily subjected. The experience with the tables in the biological laboratories in this institution has been so satisfactory that it is thought possible that a description of the manner in which the tops were treated may be of assistance to other instructors. When the laboratories were opened here, eight years ago, tables for the accommodation of thirty students were constructed. The legs and sides were first oiled so as to prevent drops of the stain applied to the top from making spots upon other parts upon which it might be spattered. The freshly planed soft wood tops, free from spots of grease, were covered with a solution made by boiling logwood chips in an iron kettle. No definite proportion of chips and water was used, but a fairly strong solution was made. This was generously applied with a brush or swab and allowed to dry thoroughly. A second coat was applied in the same way and dried. Then a strong solution of copperas in hot water followed. When dry, the table top was well rubbed with sandpaper, and hot paraffin of high melting point (55° to 60° C.) poured on. By means of a hot flat-iron the paraffin was thoroughly rubbed into the wood, thus filling all the pores and coating the surface. When cool, the superfluous paraffin was removed by scraping the surface with a thin piece of steel (back of saw-blade) having a smooth, straight edge. The tops were then ready for use. The tables in these laboratories have been in use for eight years by a number of students varying each year from one hundred to one hundred fifty, and have

never been repaired, and while not so fresh looking as when new, they are still quite presentable in appearance. During this time, the tops have undergone very hard usage. Strong acids, as sulphuric, nitric and hydrochloric, intense stains like carbol-fuchsin and haematoxylin, concentrated potash solution, alcohol from lamps, as well as various other corrosive and staining reagents, have all been spilled upon the tops, often in large quantities, and but very little damage has resulted. Oftentimes the reagent has left no trace whatever. Then, too, heavy microscopes, dissecting pans, and trays have been moved roughly about, leaving few if any marks. Besides being easily cleaned from stains, fragments of tissue, and so forth, the black surface makes an excellent background, against which light-colored objects, as small alcoholic specimens for dissection, stand out distinctly. There is, furthermore, no reflection to interfere with careful illumination of objects under the microscope. For general purposes, where many kinds of work must be done on the same tables, as is the case in all the smaller institutions, it is thought that the best satisfaction will be given by tables prepared as described above. The treatment is cheap, durable, and serves a number of purposes.

CHARLES WRIGHT DODGE.

University of Rochester.

A Note on the Quantitative Determination of the Adulteration of Wheat Flour with Maize Products.

It is the purpose of this note to report the results of experiments made to determine the degree of accuracy which can readily be obtained in the determination of the percentage of adulteration of wheat flours with maize starch or maize flour. For this purpose six mixtures of high-grade maize starch with wheat flour were prepared, containing five, ten, twenty, thirty, forty and fifty per cent. of maize starch respectively. Three more mixtures were prepared from the same materials, in proportions unknown to the operator.

One gram of each mixture was carefully mixed in a small beaker with 20cc. of the following mounting medium:

Glycerin, 2 volumes,
Glacial acetic acid, 1 volume,
Distilled water, 1 volume.

The glycerin prevents the rapid evaporation of the mounting fluid, while the acetic acid renders the characteristic ap-

pearance of the maize starch grains somewhat more definite. If 20 cc. of this liquid be used for one gram of the sample, a mixture will be obtained having about the proper dilution for the ready counting of the grains under the microscope. The eyepiece of the microscope used was provided with a micrometer ruled in squares one mm. on a side. There were twenty-five of these squares in the central part of the field. In the case of each preparation the grains were counted within the limits of these twenty-five squares, and the slide was moved so as to bring the next adjoining area of the same size in the position occupied by the grains just counted. This was repeated until five fields had been counted. The average ratios for each of the six known mixtures and for the three unknown mixtures were as follows:

MIXTURE.	Ratio of number of grains of corn starch to number of grains of wheat starch.
5 per cent.	1 : 276.0
10 " "	1 : 59.3
20 " "	1 : 30.6
30 " "	1 : 19.1
40 " "	1 : 13.6
50 " "	1 : 14.0
Unknown Mixture A	1 : 20.6
" " B	1 : 195.7
" " C	1 : 37.8

The percentage of corn starch in each unknown mixture was calculated on the basis of the ratios obtained for each of the known mixtures, except that in the cases of mixtures A and C the ratio for the known mixture containing five per cent. of corn flour was omitted.

Mixture A.—Ratio of number of maize starch grains to number of wheat starch grains was found to be 1:20.6. The ratio obtained for the 10% mixture indicates that this sample contains 28.8% of maize starch; the ratio for the 20% mixture indicates 29.7%; the ratio for the 30% mixture indicates 27.8%; the ratio for the 40% mixture indicates 26.4%; and the ratio for the 50% mixture indicates 34.0%. The average of these is 29.3%. The theoretical percentage of maize starch in mixture A was 32.5%.

Mixture B.—Mixture B gave the average ratio of 1:195.7. The ratio obtained for the 5% mixture indicates that mixture B contains 7.05% of maize starch; the ratio for the 10% mixture indicates 3.03%; for the 20% mixture, 3.64%; for the 30% mixture, 2.93%; for the 40% mixture, 2.77%; and for the 50% mixture, 3.57%. The average of all of these is 3.83%. The theoretical percentage of corn starch in mixture B was 7.75%.

Mixture C.—The ratio of the number of grains of maize starch in mixture C to the number of grains of wheat starch was found to be 1:37.8. The ratio obtained for the 10% mixture indicates that this sample contains 15.7% of maize starch; the 20% mixture, 16.2 per cent; the 30% mixture, 15.2%; the 40% mixture, 14.4%; the 50% mixture, 18.5%. The average of all of these is 16.0%. The theoretical percentage of corn starch in mixture C was 21.0%.

It appears from these results that the greatest difference between the theoretical percentage and the percentage found was 5.0 per cent. These figures were obtained by rapid work, and there was no time to repeat the determinations. By counting a considerably larger number of microscopic fields for each sample, say ten or twenty instead of five, as was the case in these experiments, the difference between the theoretical percentages and percentages found would undoubtedly be considerably lessened.

There are two very apparent errors in the data given: The number of grains of wheat starch to one of corn starch in the 5 per cent mixture is undoubtedly too high, while the corresponding number for the forty per cent. mixture is evidently too low.

In the case of materials adulterated with maize flour instead of maize starch the difficulty of the determination would undoubtedly be considerably increased. If the nature of the maize product used as the adulterant is known to the operator the work will be considerably facilitated. If possible, he should obtain a sample of the material and prepare mixtures of it with a good quality of wheat flour and use the data obtained by counting the number of wheat and maize starch grains contained therein as a basis of comparison with unknown samples.

While it is not likely that it will often be necessary or desirable to determine quantitatively maize starch or other maize products in mixture with wheat flour, these results are offered as a suggestion for persons who may find it necessary to make such determinations.

E. E. EWELL.

Laboratory of the Division of Chemistry of the U. S. Department of Agriculture, July 1, 1898.

Corks and Labels.

The corks of bottles containing alcoholic specimens last only a few years, soon decaying and allowing the alcohol to evaporate. Labels also become macerated if placed in alcohol, and writing

becomes indistinct and finally so blurred and faint as to be illegible. This has caused many to adopt the plan of pasting the label on the outside of the bottle instead of placing it inside, where it should properly be. Even if the labels are made of parchment paper, they will change color in the alcohol and become unsightly.

To counteract the destruction of labels and corks I have for some time used paraffin with entire success. The process is of course very simple. After the labels have been written and become perfectly dry, they are dipped in melted paraffin. The time of immersion should be sufficient to allow the paraffin to soak through the paper and make it semi-transparent, from a few seconds to one minute. When the label is taken out, the superfluous paraffin is drained off and in a few seconds more the paraffin has hardened sufficiently to allow the label to be placed in the bottle with the alcoholic specimens. It is now practically indestructible and will last as long as the specimens, without deteriorating in color or composition. Other labels may be treated in the same way. Such labels can not be tampered with afterwards, as the paraffin prevents the writing from being destroyed or erased, and also prevents any writing from being added to the old label.

The corks should be perfectly dry and new. Place them in the boiling or melted paraffin for a few minutes. The paraffin will enter and fill up the pores. When the cork is inserted in the bottle a string should be placed at one side in order to allow the air to escape, otherwise the cork will not stay in the bottle. Next a small white label is stuck on the cork and held there by two short pins. This label need not contain anything but the number and the name of the specimen. The next step is to dip the neck of the bottle and cork in the paraffin, thus causing it to be hermetically sealed.

Bottles treated in this manner do not require refilling, as the alcohol does not evaporate and their labels will always remain clean and neat.

GUSTAV EISEN.

California Academy of Sciences, San Francisco, Cal.

Cover glasses and slides may be cleaned by immersing them in fluid made by adding to a saturated aqueous solution of potassium bichromate, about one-eighth of its bulk of strong sulphuric acid. Allow the mixture to cool before using. After the glasses have remained in the solution for an hour, wash thoroughly in water and dry with a clean cloth.

Some Apparatus to Facilitate the Work of the Histological and Embryological Laboratory.

Every teacher who has to direct the work of beginning classes and of thesis and research students, is compelled from time to time to make modifications of

tention is called to the following pieces of apparatus, hoping that they will serve to give hints to other teachers, and trusting that they, or some modification to meet special needs, will prove as serviceable to other laboratories as they have to my own. Most of them have been figured and described already in some form. The figures here given re-

Name of Article	Round Aquarium	Cost, \$	6.00
	Jars (1 Liter capacity).	No of Pieces	24
From	Whitall Tatum Co.	Inventoried	1898
Address	46, 48 Barclay St. N.Y.		
Order No.	113	Date	June 15, 1898
Date of receipt of Articles	July 2, 1898		
Remarks	Used for waste jars and for water.		
DEPT.	Histology	NEW YORK STATE VETERINARY COLLEGE, CORNELL UNIVERSITY.	

Fig. 1. Inventory card.

apparatus, or under special stress to construct wholly new pieces. Indeed, as has been well said, a laboratory teacher who is not also something of an inventor cannot attain the highest success. At-

present the latest and most satisfactory modifications.

To begin with, the laboratory teacher is in most cases held responsible for the property of the laboratory, and it falls

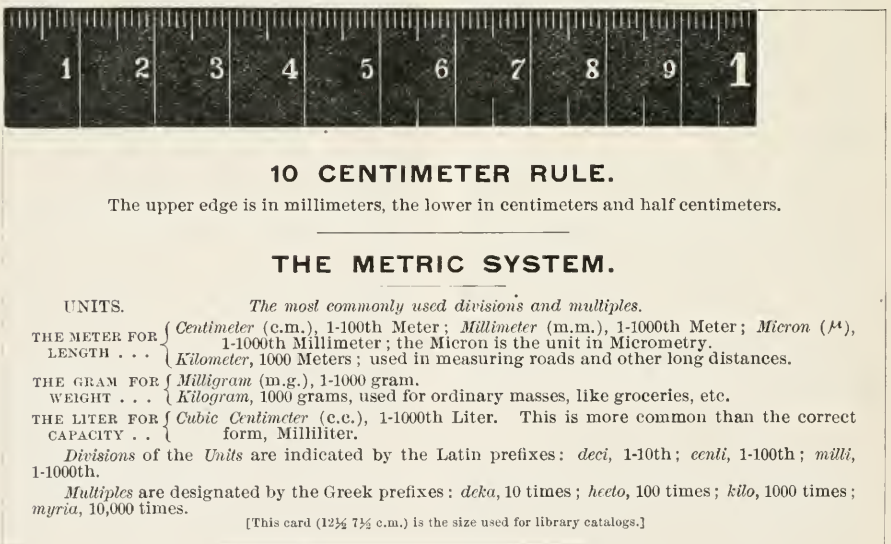

Fig. 2. The metric system in a nut-shell.

to him to indicate what is necessary to carry on the work. To facilitate this labor, and to make easily accessible a knowledge of the cost, place of purchase or the time required to obtain any piece of apparatus or any material needed in the laboratory, the catalog blank (Fig. 1) has been evolved during the last 10 years. The card has been filled out in script from an actual case. In addition to the information given in this card, there is usually present a mark showing where the apparatus is to be found, thus adopting the principle of shelf marking used in libraries.

To facilitate the understanding of the metric system which is required in all our work each student is supplied with a card of the standard size used in library catalogs, shown in Fig. 2.



Fig. 3. Laboratory Table, adjustable stool, water and waste jars, and screen.

The most convenient size for a laboratory table is about 125 cm. long, 72 cm. wide, and 72 cm. high, (48 in. long, 28 in. wide and 28 or 29 in. high); and for a seat, an adjustable piano stool, costing from \$1.50 to \$2.00.

For the most critical microscopic work one most conveniently faces the light; this is hard on the eyes and hence some form of a screen is exceedingly useful. Those figured in Fig. 3, 4 were made by inserting a wire in a tin patty dish and filling the dish with lead. The wire is bent at right angles and a sheet of heavy paper high enough to screen the eyes and low enough to shade the stage, but not to interfere with the mirror is hung on the bent wire.

Many workers find no difficulty in keeping both eyes open, simply neglecting the images of the eye outside the

ocular, but the majority find it hard to do this. Various eye shades have been devised to obviate the trouble.

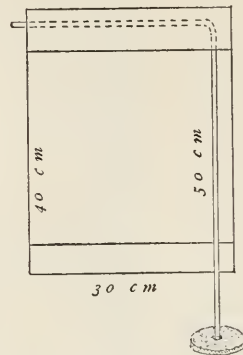

Fig. 4. Screen for shading the microscope and the face of the observer.

One which has the advantage that it may be used for either eye and thus encourages the use of the eyes alternately is shown in Fig. 5.

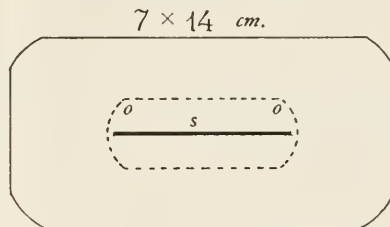

Fig. 5. Double Eye-Shade. This is readily made by taking some thick bristol board 7 x 14 centimeters and making an oblong opening with rounded ends (o—o) and of such a diameter that it goes readily over the tube of the microscope. This is then covered on both sides with velveteen and a central slit (s) made in the cloth. This admits the tube of the microscope and holds the screen in position. It may readily be pulled from side to side and thus serves for either eye, or for the use of the eyes alternately.

Twenty years experience has shown that in a laboratory there must either be a microscope for each student, which is the best plan—or some arrangement by which two or more can use one microscope and be held responsible for it. The form of cabinet finally adopted is shown in Fig. 6.

The outside doors put the entire equipment under the control of the teacher. The small lockers make it possible to give each microscope to a definite number of students, who can be held accountable for it.

In order that specimens may have a neat appearance and be uniform, it is a

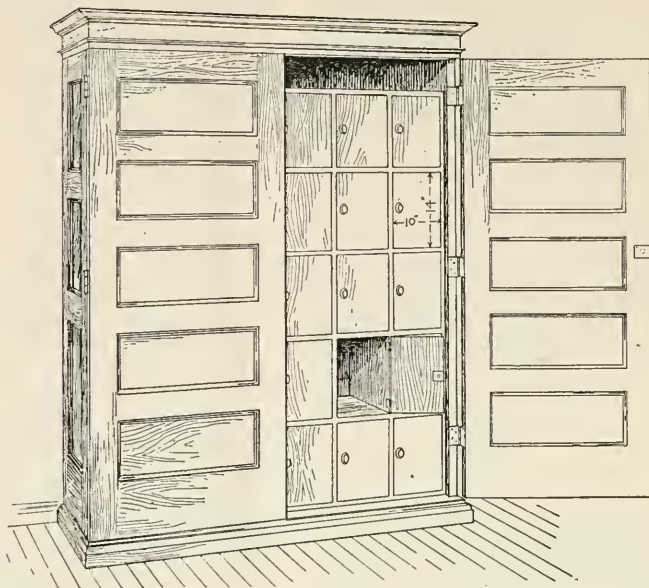

Fig. 6. Cabinet for Microscopes.

great help for beginners to have some kind of a guide in mounting. Fig. 7 shows such a device.

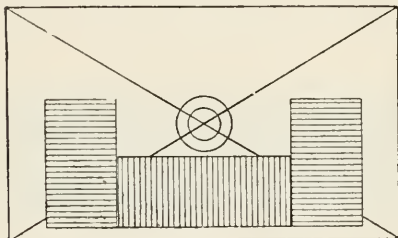

Fig. 7.

A convenient label is shown in Fig. 8. As illustrated in the filled out label the thickness both of the cover-glass and

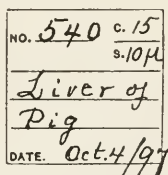

Fig. 8.

of the section is indicated. The thickness of the cover is in hundredths of a millimeter, that of the sections in microns (μ).

As it is desirable to have every student independent each should be given, if possible, an individual locker for his specimens and material. The lockers available in the histological laboratory at Cornell are shown in Fig. 9. For each there are several reagent boards with holes of various sizes and a drawer. Some of the reagent boards have holes about 25 mm. in diameter for the preparation vials shown in Fig. 12, and they also serve very well indeed for storing paraffin imbedded tissues.

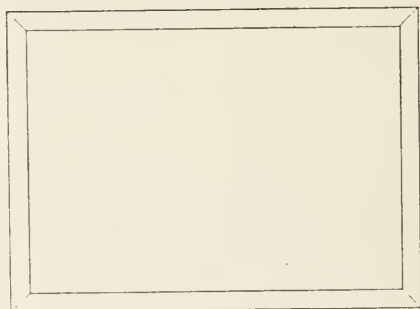

Fig. 10.

For paraffin ribbons and for temporary mounts or for working series the rather expensive slide drawers (Fig. 10 A) and

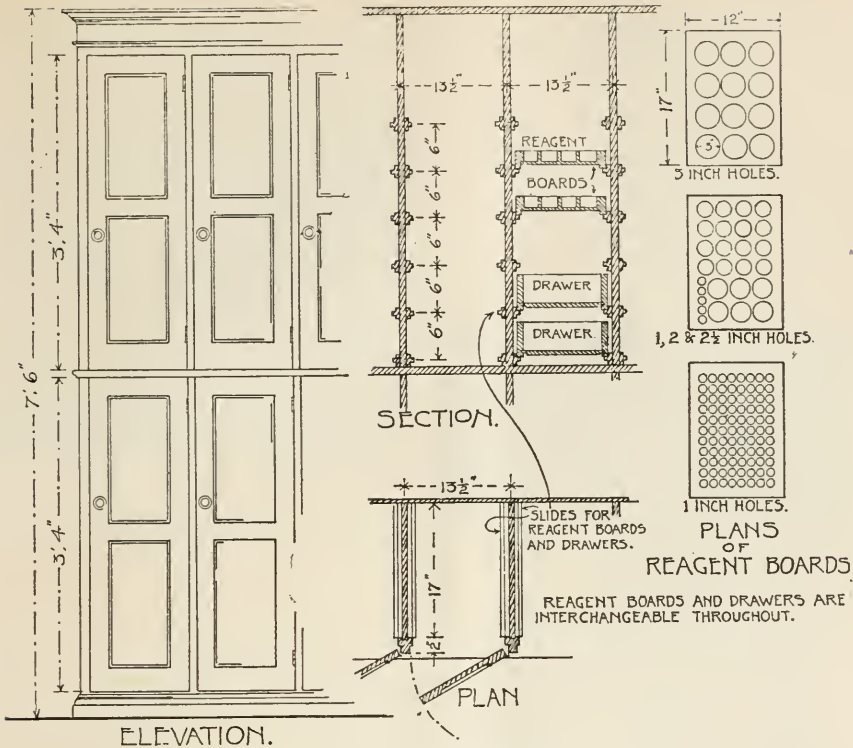

Fig. 9. Lockers and Reagent Boards.



Fig. 10A.

Fig. 10 and 10 A. Face and sectional views of slide drawers.

cabinets are hardly available, and not altogether suitable. Instead, shallow drawers are used. One is shown in face and in sectional view in Fig. 10.

These fit the lockers and several of them may take the place of a reagent board or a drawer. As they have an edge all around, any one may easily be removed without disturbing the others. Each drawer is about 30x43 centimeters (12x17 in.) and holds 50 slides. They cost only about \$12.00 per hundred and have proved a great convenience during the two years in which they have been in use.

There have already appeared descriptions of two markers in the Journal, showing how widely the need has been felt. Probably a dozen different methods have been devised for finding some part of a microscopic specimen. The marker here shown is simple and has proved of great help for marking specimens to be used in class demonstrations and in special study. This form of a finder has the advantage that a slide marked by it can be used on any microscope.

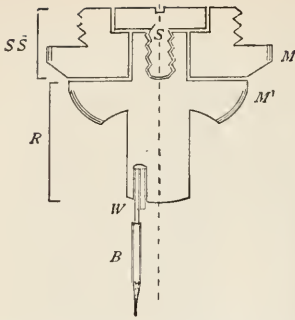
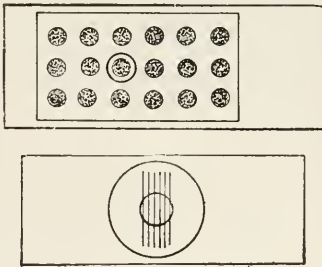

Fig. 11. The marker consists of the part SS with the milled edge (M). This part bears the Society or objective screw for attaching the marker to the microscope. R. Rotating part of the marker. This bears the eccentric brush (B) at its lower end. This brush is on a wire (W). This wire is eccentric, and may be made more or less so by bending the wire. The central dotted line coincides with the axis of the microscope. The revolving part is connected with the "Society Screw" by the small screw (S).



Section of a series marked to indicate that this section shows something especially well. The lines of a micrometer are ringed to facilitate finding the lines.

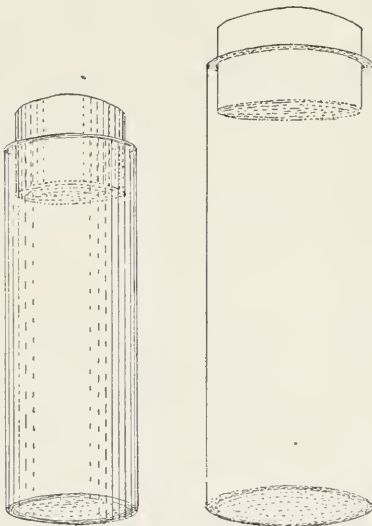

Fig. 12. Shell vials.

For much of the work of histology and embryology, small wide-mouth shell vials are very convenient. Three sizes have answered most purposes, 18x50 mm., 23x65mm., and 35x90 mm. The lips should be slightly flared. The cost is \$2.00 per gross for the smaller ones and \$6.00 per gross for the largest ones. These are not good for long storage. They are for preparing objects. For long storage nothing is so satisfactory as a glass stoppered bottle. The larger of these vials takes a slide and is very useful for staining, clearing, etc.

For reagents which are to be used with a dropper or pipette, bottles of various sizes are employed. That volatile liquids shall not evaporate, a cork is perforated and put over the glass tube as shown in the figure.



Fig. 13. Reagent bottle with combined cork and pipette.

For preparing objects a waste bowl or dish with a rack on the top for supporting the slides, a drainage funnel, etc., is very convenient. One may use an ordinary bowl or preferably an aquarium jar. (Fig. 3). The rack is made of two pieces of sheet lead into which are soldered brass rods. The funnel is made of brass or copper.

For balsam, and homogeneous oil, no receptacle has been satisfactory for daily use except a capped bottle like a small spirit lamp. Fig. 15.

A moist chamber for blood preparations, etc., can be very simply made with a bowl or an aquarium jar and a white dinner plate.

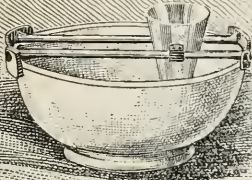

Fig. 14. Waste bowl with rack and drainage funnel (see also Fig. 3).

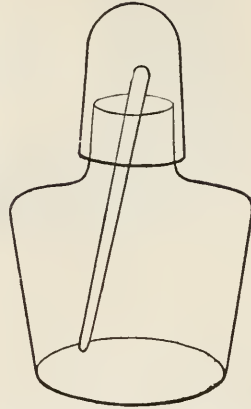

Fig. 15. Capped holder for Balsam and homogeneous oil with glass rod.

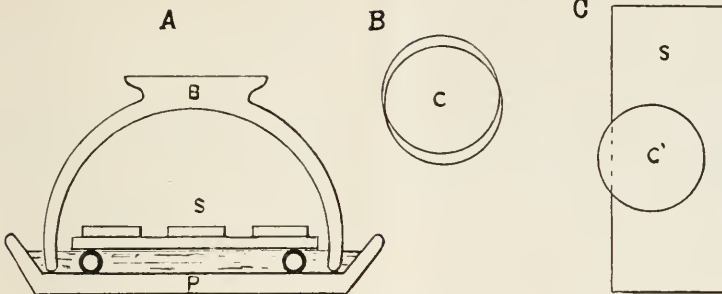

Fig. 16. Simple moist chamber.

In handling amphibian eggs and other small and delicate objects an egg pipette may be easily made by cutting off a short medicine dropper and adding to the tip some soft rubber tubing. It is easy with this to catch and handle young embryos of frogs, salamanders, etc.

Objects fixed with osmic acid alone or in combination with chromic acid or platinic chlorid (Flemming's or Hermann's solutions, etc.), require to be washed out a long time in running water. To accomplish this washing without danger to the tissue and still thoroughly, the following arrangement was devised: A small side tap was put in the pipe leading to the ordinary faucet. A copper box with a small tube near the bottom was put at one corner and this was connected with the washing tap by a rubber tube. A skeleton box with projecting edge was then made to fit inside



Fig. 17. Egg-pipette.

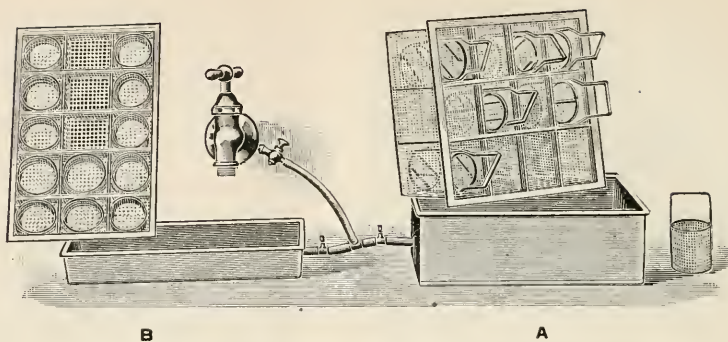

Fig. 18. Washing apparatus for tissues fixed in osmic acid, etc.

the receiver. This skeleton, inside box is divided up into a dozen compartments and for each a little basket is prepared. The tissue is put into the little baskets and they are placed in the compartments as shown in the figure (Fig. 18 A).

The outside box is about 1 centimeter deeper than the inside one and the water runs in at the bottom and out over the top. This insures a constant change of the water, and as the water enters at the bottom it must pass through the perforations of the inside box and of the little basket before coming in contact with the tissue; it can be seen that the current is very gentle when it

reaches the tissue. This apparatus has now been in use about six months and has proved very satisfactory. The washing apparatus shown in B, will be described by one of my students in a later issue of the Journal.

For heating gelatin for injections and paraffin for filtering, etc., a combined receptacle and water bath was devised. The cut shows the construction.

For the filtered paraffin that is to be used for imbedding, a combined water bath and receptacle was devised in which the water bath nearly surrounded the paraffin receptacle as shown in the cut. For a large laboratory the paraffin receptacle should hold about one liter.

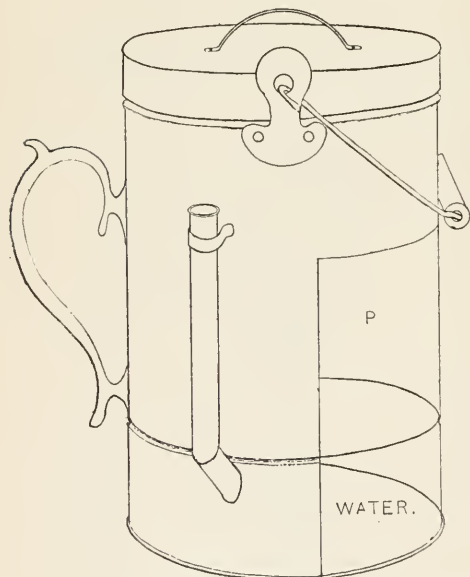

Fig. 19. Combined receptacle and water-bath for melting paraffin, and for gelatin injection masses.

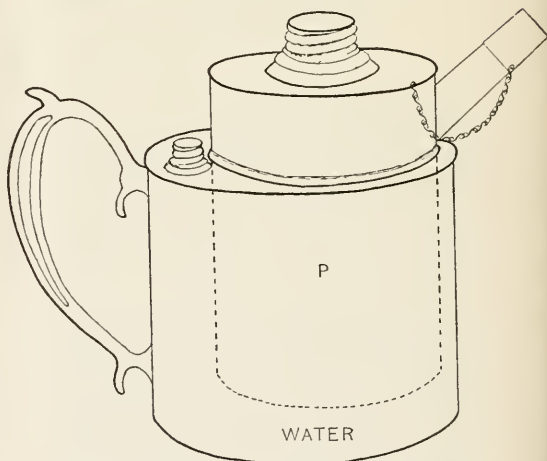

Fig. 20. Paraffin receptacle with water-bath, and spout for paraffin imbedding. P—Paraffin.

In filtering paraffin and gelatin some form of hot filter is necessary. The form here shown has worked admirably.

So much trouble was experienced in filtering from the clinging of the filter to the sides of the vessel that a wire basket leaving about 1 cm. space all

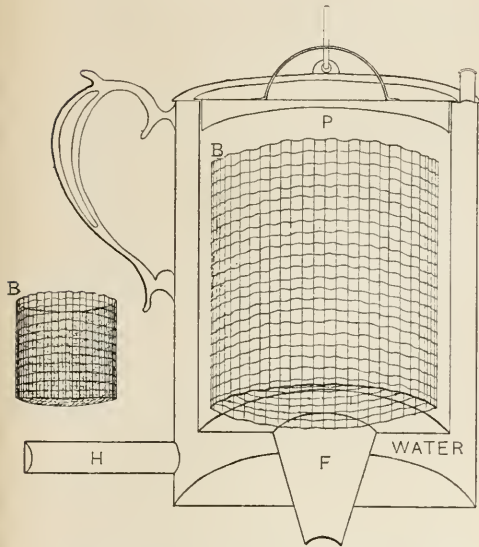

Fig. 21. Hot filter for paraffin and gelatin, in section. B. B. Wire basket somewhat smaller than the receptacle. The flannel or filter paper is put inside this. H. Closed tube continuous with the water bath. The Bunsen burner or the alcohol lamp is put under this.

F. Outlet of the filter.

P. The receptacle for the paraffin, etc. The cover fits inside P. and the whole is suspended by a bail.



Fig. 22. Screw-top copper can for collecting with a bicycle.

around was devised. The filter paper or flannel is put in this and the paraffin or gelatin is then poured in as usual and as the filtered material oozes through the sides it runs down the wires to the outlet.

For collecting with a bicycle I have found a can with a very large screw top very convenient. It is water tight in any position, and can be easily put into almost any form of bicycle carrier. A leather bag attached to the handle bars has proved convenient. Many times one needs considerable space and a pair of two-liter cans have frequently been carried.

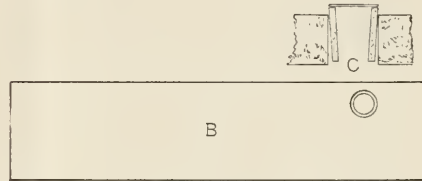

Fig. 23. Circulation-board for Necturi and frogs. It is composed of a board about 8 x 30 centimeters with a perforated cork bearing a thick cover inserted in a hole near one edge. B. The circulation board. It is covered with cloth or blotting paper. C. Sectional view showing the covered cork in place.

All the metal apparatus described in this article has been made of copper or brass, tin rusts out too soon. For the washing outfit (Fig. 18) wire netting may be used, but perforated copper or brass is more satisfactory, (Fig. 18 B).

SIMON HENRY GAGE.

Cornell University, July 18, 1898.

A Durable Stain for Starch.

In vegetable histology no other reagent is used so frequently as iodine either alone or in combination. Unfortunately its effect however is transient, especially where starch grains are concerned, and consequently when permanent preparations showing these bodies stained are desired some other reagent must be employed. In the *Zeitschrift für wissenschaftliche Mikroskopie* Band XIV, Heft 3. Dec. 1897, Dr. G. Lagerheim has described an easy method of making permanent stains of starch bodies.

The essence of the method lies in the precipitation of silver in the starch grains, the latter retaining a beautiful yellowish brown to dark brown color which is durable.

The material to be colored is killed with alcohol. If it contains chlorophyll, the specimen is left in the alcohol until decolorized.

For the latter purpose Eau de Javelle

may advantageously be used since this destroys the plasmatic bodies in the cell without injuring the starch bodies. The specimen prepared as above is laid while damp upon a slide and treated until the starch grains turn blue with a mixture of water 15g., iodide of potassium 1.5., and iodine 0.05 g. A drop of this iodine solution is usually sufficient for small preparations. The colored preparation is then washed with distilled water until the cell membrane and the plasma have lost their iodine color. Then put on one to several drops according to the size of the preparation, of a solution of silver nitrate and place it in a bright light for a few moments.

The preparation then becomes white or yellowish white through the precipitation of iodide of silver in the starch grains. The iodide of silver may now be reduced by the use of a "developer." This consists of distilled water 100g., sodium sulphite 10g., hydrochinon 2g. If this developer is used, to each cubic centimeter of the same is added a drop of a ten percent. solution of potassium carbonate. The iodide of silver preparation previously washed out carefully in distilled water is then treated, according to its size, with one to several drops of this mixture. The preparation now becomes a soft brown. If it has a reddish brown color, it is washed out with water and mounted in glycerine. In successful preparations the starch grains retain their original form and structure and are colored a beautiful yellowish brown. Cell membranes and protoplasm remain colorless. If they retain a yellowish color or if there is a fine, colored precipitate in the cell then the iodine solution has not been washed out with sufficient care.

The color of starch grains treated as above may be "intensified." To do this the colored specimen is treated until it is white with a solution of 1g. of sublimate and 1g. of potassium bromide in 50cc. of water.

Then it is very carefully washed out with water and treated with the hydrochinon developer in the manner mentioned above. By this method the starch grains are colored a dark brown.

A reddish brown coloration may be obtained by using palladium. The section stained as above in the iodine-potassium iodide solution is well washed with water, then heated with a solution of palladium chloride (Pg. Cl. 2) 0.2 gramme in 20 grammes of water, and after a few minutes again carefully washed in water. The starch grains then have a beautiful brown color.

CHARLES WRIGHT DODGE.

University of Rochester.

Notes on Microscopical Technique.

G. CARL HUBER, M. D.

Fifth Paper.

METHODS FOR MICROSCOPIC EXAMINATION OF HUMAN BLOOD.

The microscopical examination of the blood has in recent years become such an important part of systematic clinical examinations, that many clinicians have recourse to it, not only in diseases of the blood and hematopoietic organs, but also in a great variety of other pathological conditions. It seemed advisable, therefore, to draw attention to some of the methods used in such an examination, in the closing article of this series on elementary microscopical technique.

In doing so, I shall follow the plan adopted in the other articles, of treating the subject in a most elementary way, not so much with a view of aiding those who may already have a working knowledge of these methods, but rather those not as yet familiar with them. Space does not permit more than a discussion of the methods to be used. For an account of the structural elements of normal blood, their variation in structure, and relative proposition in pathological conditions, the reader is referred to the special text-books on the subject.

COUNTING BLOOD CELLS.

The instrument now generally used for this purpose is the Thoma-Zeiss haemacytometer. This apparatus consists of two parts, pipettes by means of which the blood is diluted one hundred times, when counting red, or ten times when white blood cells are to be counted; and a glass slide, on which there is a small well of known depth, the bottom of the well being divided off into small squares. The pipette used when counting the red cells consists of a capillary tube, near the middle of which there is an ampullar enlargement. This is so graduated that the cubical contents of the capillary tube are just one-hundredth part of the cubical contents of the ampulla. The blood to be examined is drawn into the capillary tube, to a line marked "1" (just below the ampulla); the end of the pipette is then inserted into the diluting fluid, and this is sucked up until the diluted blood reaches a line marked "101" (just above the ampulla). The pipette is then carefully shaken to mix thoroughly the blood and the diluting fluid.

Either of the following two solutions may be used for diluting the blood:

Hayem's Solution.—Bichloride of mercury, 0.5 gram; sodium chloride, 1.0 gram; sodium sulphate, 5.0 grams; distilled water, 200.0 cc.

Toyson's Fluid (as given by Kahlden).
 --Methyl violet 5 B, 0.025 grams; neut-
 ral glycerin, 30.0 cc.; distilled water,
 80.0 cc.

Mix methyl violet in glycerin and the
 distilled water and to this solution add:
 sodium chloride (C. P.), 1.0 gram; sod-
 ium sulphate (C. P.), 8.0 grams; distilled
 water, 80.0 cc.

Filter, and the solution will be ready
 for use. The white blood cells are
 stained violet, and may thus be counted
 with the red.

The diluting fluid contained in the cap-
 illary tube is then blown out, and a
 small drop of the diluted blood is placed
 on the center of the small glass disc.
 This small disc is surrounded by a ring
 of glass, cemented to the slide. The
 glass ring is 0.1 mm. thicker than the
 glass disc.

When this small moist chamber is
 covered with a thick cover-glass, we
 have a layer of blood 0.1 mm. deep be-
 tween the disc and the cover-glass. On
 the upper surface of the small glass
 disc (on which the drop of diluted blood
 was placed) there are marked off four
 hundred small squares.

The sides of the small squares are one-
 twentieth of a millimeter long.

It will be seen that the layer of blood
 over each of the squares would have a
 cubic contents of

$$\frac{1}{4000} \text{ of a c. m. m. } \left(\frac{1}{20} \times \frac{1}{20} \times \frac{1}{10} = \frac{1}{4000} \right).$$

The haemacytometer slide is now placed
 on the stage of the microscope, where it
 should remain undisturbed for several
 minutes before counting. The red blood
 cells in twenty-five to fifty squares are
 then counted. To ascertain the number
 of red cells in a cubic millimeter, the
 following formula may be useful:

$$\frac{4000 \left\{ \begin{array}{l} \text{Each cube of blood counted} \\ \text{has a cubical contents of} \\ \frac{1}{4000} \text{ c. m. m.} \end{array} \right\} \times d \left\{ \begin{array}{l} \text{The dilution of} \\ \text{the blood, which} \\ \text{would be 100} \end{array} \right\} \times n \left\{ \begin{array}{l} \text{The number} \\ \text{of red cells} \\ \text{counted} \end{array} \right\}}{n \text{ sq (the number of squares counted)}} = \left\{ \begin{array}{l} \text{The number of red} \\ \text{blood cells in} \\ \text{1 c. m. m.} \end{array} \right.$$

Or, ascertain the average of the red
 blood cells in the squares counted, and
 multiply this number by 400,000.

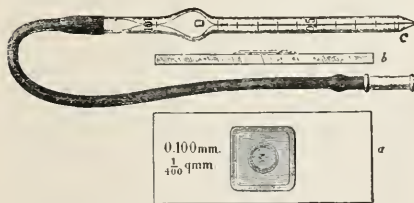

Fig. 1. Thoma-Zeiss haemacytometer: a,
 slide used in counting blood cells; b, same
 in section; c, pipette used in diluting blood
 when counting the red blood cells.

In case it is desired to count only the
 white blood corpuscles, a one-third per
 cent. solution of glacial acetic acid is
 used for diluting the blood. This solution
 bleaches the red cells, and brings out
 clearly the white corpuscles.

The blood is diluted only ten times, us-
 ing for this purpose the Thoma-Zeiss
 pipette for counting white corpuscles.
 The formula then reads as follows:

$$\frac{4000 \times d (10) \times n \left\{ \begin{array}{l} \text{The number of} \\ \text{white blood cor-} \\ \text{puscles counted} \end{array} \right\}}{n \text{ (number of squares counted)}} = \left\{ \begin{array}{l} \text{The number} \\ \text{of white} \\ \text{blood cells} \\ \text{found in} \\ \text{cubic} \\ \text{millimeter.} \end{array} \right.$$

Or, multiply the average number of
 white corpuscles in each square by
 40,000.

METHODS FOR OBTAINING, FIXING, AND
 STAINING BLOOD PREPARATIONS.

In order to be able to examine micros-
 copically blood preparations it is neces-
 sary to have the blood spread in a very
 thin layer, and in such a way that such
 preparations may be readily fixed and
 stained. This may be done in several
 ways. The method here given is es-
 sentially that suggested by Ehrlich, to
 whom we owe so much of the technique
 in this field and so many observations
 on the structure of the blood in its
 normal and pathological state.

The blood is best spread on cover-
 glasses; a convenient size is a No. 1,
 three-fourth inch square cover-glass.
 The size is not so essential, but it is
 necessary that they be very thin.

Before using, the cover-glasses should
 be thoroughly cleaned. This is best done
 by washing them in sulphuric acid, rins-
 ing them in water, washing them in

strong acetic acid, again washing thor-
 oughly in water, and wiping them from
 alcohol, with a soft, clean cloth. Cover-
 glasses thus cleaned may be kept on
 hand ready for use.

The steps for obtaining "blood-
 spreads" are as follows: The blood may
 be obtained from a finger, the lobe of the
 ear, or in infants from the large toe.
 The part should be cleaned by washing,
 and it is well to wipe it with a cloth dip-
 ped in alcohol or alcohol and ether. Spe-
 cial instruments have been devised for
 incising the skin to cause the blood to
 flow. I have used, for some time, an
 ordinary steel pen, from which one of
 the prongs has been broken, for this pur-
 pose. This little instrument is readily

sterilized by heat and may be thrown away when once used.

The part should be pricked sufficiently deep to cause the blood to flow without the need of much pressure. After pressing out a few drops, which are wiped away with a clean, dry cloth, a relatively small drop is pressed out and caught near the edge of a cover-glass, held in the ordinary cover-glass forceps.

This is quickly placed, blood side down, on another cover-glass, care being taken to overlap the two covers, only about one-half, and to keep their edges parallel. The drop of blood instantly spreads out between the two covers. They are now quickly drawn apart, and if the covers are thin and clean, a thin film of blood will be found on them. They are now placed aside, blood side up, and allowed to dry. The spreading of blood is greatly facilitated by the use of a forceps which Ehrlich has suggested for this purpose.



Fig. 2. Ehrlich's cover-glass forceps, for holding cover-glasses for securing thin film of blood.

The manner of using these forceps is as follows: before taking up a drop of blood on a cover-glass, as above directed, a cover-glass is fastened in Ehrlich's forceps, near the end, and in such a way that about three-fourths of the cover project to the right of the forceps when held in front of the operator.

The Ehrlich's forceps, with the cover-glass properly clamped, is held in the left hand, with the ordinary cover-glass forceps held in the other hand; a cover is picked up, a drop of blood is caught on its under surface, near its further edge, and it is now placed on the cover held in the Ehrlich's forceps, care being taken to overlap the two covers only about half and to keeping their edges parallel. The two cover-glasses are now quickly drawn apart.

The film of blood on the cover held in Ehrlich's forceps is usually spread much better than on the cover-glass drawn off. The former is kept, while the latter may be turned over and used again for spreading the blood on another cover-glass. Some eight to ten covers are spread after this manner and placed aside to dry.

Two methods may be used for fixing the blood on the cover-glass:

1. It may be hardened in a solution of equal parts of absolute alcohol and ether, in which solution the cover-glasses with the blood may remain about two hours; in it they may, however, remain for twen-

ty-four to forty-eight hours without injury. The preparations are then taken from the ether and alcoholic solution and placed on filter paper until the fixing fluid has evaporated, when they are ready for staining. It is hardly necessary to add that the ether and alcohol solution should be well covered up while in use, to prevent evaporation. It may be kept in a well stoppered wide-mouth bottle, and may be used over and over again for the purpose of fixing blood preparations.

2. Ehrlich recommends the fixing of blood preparation by heat. He has suggested a very simple apparatus, shown in Fig. 3, by means of which blood may thus be fixed.

It consists of a copper plate about fifteen inches long, four wide, and one-eighth inch thick. The copper plate is heated at one end by means of an alcoholic or gas flame.

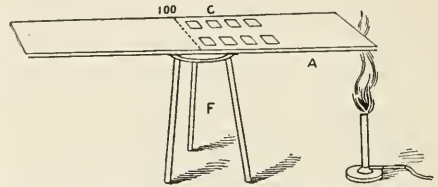

Fig. 3. Plate for heating blood preparations: a, copper plate; c, blood preparations; f, tripod.

If then, at the end of fifteen minutes, a moistened glass rod is passed over the plate, beginning at the end away from the flame, a place will be reached where the water begins to boil. This region of the copper plate is looked upon as having a temperature of 100° C.; it is represented by a dotted line in the figure. The blood preparations (c.) are placed on the plate (blood side up) between the flame and this imaginary line (nearer the latter), and heated for a time varying with the stain to be used.

The blood preparations fixed after either of the above two methods are to be stained as follows:

Haematoxylin and Eosine.—Before staining in haematoxylin and eosine the blood preparations should be fixed in the alcohol and ether solution for a period of about two hours, or by heat, at a temperature of 100° to 110° C. roughly estimated as above directed, for forty-five to sixty minutes. They are stained in Boehmer's haematoxylin solution (mentioned in one of the former articles of this series) for fifteen to twenty minutes. This is best done by spreading the desired number of the fixed preparations, blood side up, over the bottom of a flat dish and pouring over them

enough of this haematoxylin solution to cover them. After this staining the preparations are washed for a few moments in water, most conveniently done by taking up each cover-glass with forceps and holding it under flowing water, or, if this is not at hand, by moving the preparation around in a relatively large quantity of water. The preparations are now stained for about five minutes in a one per cent. solution of eosine, they are then again washed in water, and dried between filter paper. In order to insure perfect dryness, it is well to hold the preparation for a few minutes over a flame or radiator; they may then be mounted on a drop of Canada balsam.

In blood preparations fixed and stained after this method, the nuclei of all the white blood cells are stained blue, also of the red blood cells or of other elements if such are present. The red blood cells are stained a light red by the eosine.

The protoplasm of the white blood cells, if stained at all, is a very faint red. The only granules stained in preparations fixed and stained after this method, or the eosinophilous granules of some of the white blood cells, and these a bright red.

EHRlich's NEUTROPHILE MIXTURE.

One of the best staining solutions for coloring blood preparations is that suggested by Ehrlich and known as the "neutrophile mixture." It is somewhat difficult to prepare. The following formula is practically the same as that used by Ehrlich:

Orange G (8 parts to 100 water), 130 ccm.

Acid Fuschin (20 parts to 100 water), 120ccm.

Methylen Green (12 parts to 100 water), 125 ccm.

Distilled water, 300ccm.

Absolute alcohol, 200ccm.

Glycerine, 100ccm.

Mix orange G, acid fuchsin, water, and absolute alcohol in a bottle, add slowly and while shaking the methylen green. The glycerine is then added. For staining in Ehrlich's neutrophile mixture, the preparations need to be hardened in ether and alcohol for about one hour, or fixed at a temperature of 100° to 110° C. for fifteen to thirty minutes. Float the preparation on a small quantity of the stain for about fifteen minutes, wash in flowing water, dry between several filter papers, and mount in balsam. The red corpuscles should have a reddish brown color (brick color), all nuclei green, the eosinophilous granules red, and the

neutrophile granules violet-red. The granules found in the myelocytes, cells found normally in the bone marrow, and found in the circulation only in pathological conditions, are stained like the neutrophile granules a violet-red.

It should be stated that, in order to see the finer details in preparations stained after either of the above methods, it is necessary to employ a one-tenth or one-twelfth-inch oil-immersion lens. Without this aid it becomes somewhat difficult to see the granulation in the white blood cells.

Histological Laboratory, University of Michigan.

(To be continued.)

Mounting Lichens.

In the June number of the Journal, Prof. George Pierce gives his method of fixing and imbedding specimens of this interesting group of plants. In the work with my students I have pursued a different method from that given by Prof. Pierce, and, as it has given good results, I will give it for the benefit of the readers of the Journal.

First the lichen is put into 95 per cent. alcohol for 24 hours, then into thin celloidin and thick celloidin for 24 hours each. After this the specimens are imbedded in thick celloidin which is hardened in 70 per cent. alcohol for 24 hours, and then cut. I stain cryptogams generally with borax carmine as it gives me better results than any other stain.

In this case a medium staining with borax carmine gives the fungus part of the lichen pale carmine, while the protococcus cells have a greenish red shade. This readily differentiates every cell of the host from the fungus.

Last week my class prepared sections of two of our lichens in this way—*Cladonia cornucopioides* and *Peltigera canina*—with excellent results. Other genera have been treated in the same way by former classes with equally good results.

G. H. FRENCH.

Department Biology and Physiology,
South Ill. Normal University.

An injecting mass suitable for gross dissections can be made by stirring white zinc, prepared chalk, or starch in linseed oil varnish, to the consistency of soft putty and again reducing to that of syrup with ether. The mass can be colored by stirring in chrome yellow, vermilion, or other coloring materials. The mass should be put into the vessels under as heavy pressure as is possible with the tissues treated. As the ether evaporates the mass becomes hard.

A New Portable Microscope.

Some of the very early forms of compound microscopes were constructed with a view to portability, and, up to the present time, efforts have been made to construct instruments with this par-

duction in weight has caused instability; and finally, in some which have best fulfilled all conditions, the price has been prohibitory.

The development of summer schools and field laboratories, the physician's desire to make a microscopical exami-

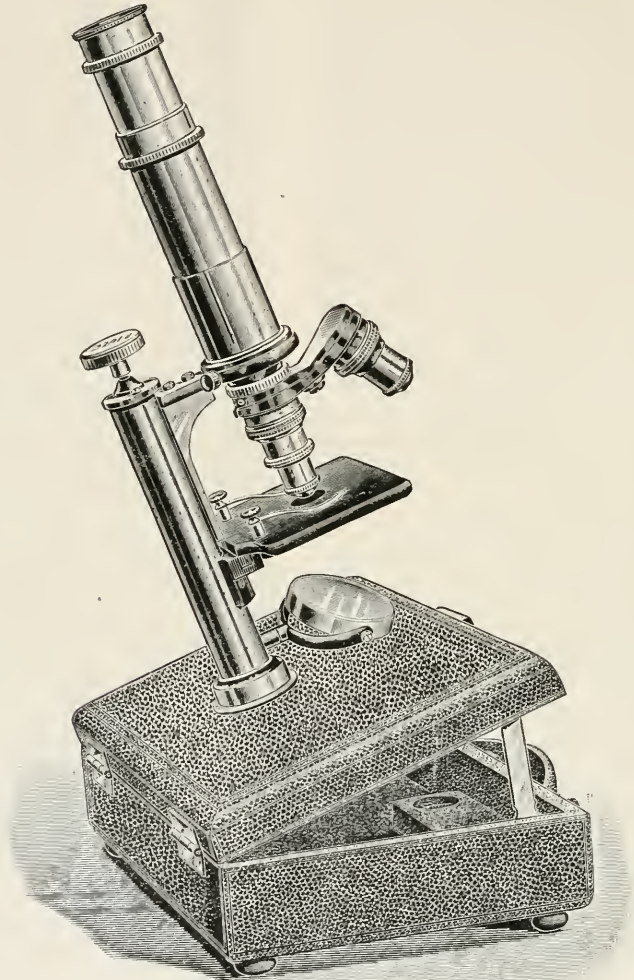

Portable Microscope, one-third actual size.

ticular end in view. Portability necessarily involves compactness, and, in the forms heretofore constructed, this feature seems to have predominated to such an extent as to detract from efficiency. In some forms, the dimensions have been reduced, resulting in a miniature microscope, while, in others, the construction of the folding parts or the re-

nation at the bedside of the patient, the needs of traveling biologists, and other users of the microscope would seem to encourage efforts in the direction of a further development of the portable microscope, and I believe the construction of which a description follows offers a satisfactory solution of the subject.

In the June number of the Journal, I described "A New Microscope Stand," and when designing it I thought I had found a satisfactory construction for the portable form. Since then, I have had one built and believe that it will meet all requirements, except of the most fastidious.

The solid pillar construction of fine adjustment, as described for "A New Microscope Stand," is retained, also the same coarse adjustment, except that a clamping screw is provided to prevent the dropping or turning of the main tube. The main tube is provided with standard size draw tube and has society screw. The stage, of liberal propor-

agement, is attached to a separate plate and may be fixed to the lower side of the stage by a locking device. This also finds room in the case.

The case is covered with leather, velvet-lined, and provided with leather handle and spring lock and key. A locknut in the cover fastens the pillar of the microscope to the case so that it cannot turn. The locknut cannot be detached from the cover.

The microscope is inclined by raising the cover of the case, which is fixed in position by two metal strips which lock into two pins in the lid. Thus the case serves as a convenient and very efficient base. The case is $8\frac{3}{4}$ in. long, $5\frac{3}{4}$ in. wide

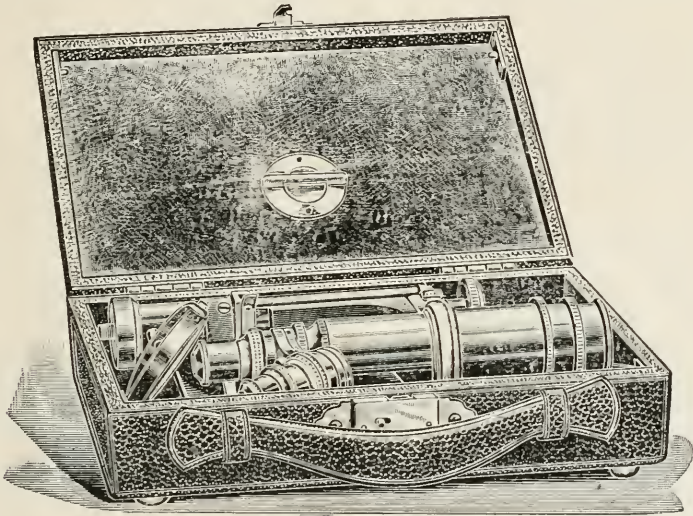

Portable Microscope in Case, one-third actual size.

tions, 3.3-4x3.3-8 inches, is hinged to a firm bracket in such a manner that when the instrument is ready to place in the case, it swings to a vertical position and sufficiently at one side of the pillar to permit the main tube to pass by. When the stage is in position for use the tongue at its rear end enters a groove in the bracket, where it is held by a strong spring catch, thus insuring its fixed position and absolute rigidity.

As shown in the figure, the instrument may have the double nosepiece, and may be opened or closed and placed in the case without removing either nosepiece, objectives, or any other part.

The simple form of the condenser, with an iris diaphragm both below and above the condenser, giving full control of the substage illumination with and without condenser, and having screw focusing adjustment and swingout ar-

and $2\frac{1}{4}$ in. high, and its total weight with microscope and optical outfit is $3\frac{3}{4}$ lbs.

EDWARD BAUSCH.

Rochester, N. Y., July 26, '98.

When the head of a blow fly is severed from the body the "tongue" is apt to collapse. A slight pressure on the head will expand it. A beautiful specimen of the expanded "tongue" may be secured by splitting a small stick for a short distance, and, before removing the knife blade, placing the head between the separated parts. When the blade is withdrawn, the head will be compressed and the "tongue" expanded. Immerse stick and "tongue" in turpentine and leave for a few days, after which it will be found well cleaned and cleared and can immediately be mounted in balsam.

Journal of Applied Microscopy.

Issued Monthly from the Publication Department
of the Bausch & Lomb Optical Co.,
Rochester, N. Y.

L. B. ELLIOTT, EDITOR.

Address all communications to
PUBLICATION DEPARTMENT,
Bausch & Lomb Optical Company,
ROCHESTER, N. Y.

One Dollar per Year. To Foreign Countries, \$1.25
per Year.

Entered at the Post-office, Rochester, N. Y., as second-class matter.

JULY, 1898.

EDITORIAL.

It is hoped that general interest will be taken by those using the microscope in the coming meeting of the American Microscopical Society, and that the attendance at the meeting will include all those who have the advancement of microscopical technique and apparatus at heart. There is certainly no way in which so much valuable information may be obtained in so quick and inexpensive a manner as at meetings of this kind. It is a common ground upon which all who use the microscope for any purpose may meet, and each carry away the valuable fruits of the others' experience. The man who uses the microscope merely as a tool for the accomplishment of a purpose, owes its development and present perfection largely to the optical and mechanical enthusiasts, while all owe the decreased prices at which apparatus can be purchased and the number of places at which microscopical appliances can be obtained throughout the country to the demand created by the professional users of the instrument. There are innumerable ways in which one class of microscope users is dependent upon the other, and we hope to see at this meeting a large attendance from the ranks of all classes of those having a common interest in this branch of science.

The number of blanks for the Journal of Applied Microscopy Microscopical Directory which have been returned since our last issue, has been very satisfactory indeed, showing a widespread desire for a directory of this kind. It is our pres-

ent purpose to publish the directory in the form of an annual, in which a considerable amount of original matter regarding microscopical technique will be included as well as a quantity of statistical material and useful formulae. All names will be inserted in the directory gratis, and we trust that our friends will send for extra blanks on which to enroll the names of those not subscribers to the Journal, but who are interested in microscopy. If the secretaries of societies will kindly forward the entire list of their members with the information desired for each name, we will be pleased to insert the list under the separate heading for societies. As many separate blanks as desired will be forwarded postpaid. Directors of laboratories will no doubt confer a favor upon their advanced students by calling their attention to this opportunity.

We desire to have upon our exchange list all societies and institutions issuing publications on biology, mineralogy, and allied subjects. These publications as received will be placed in the Journal library, where they will serve as reference works in answering the inquiries which the Journal is continually receiving. Books and reprints sent for review are also ultimately deposited in the Journal library.

NEWS AND NOTES.

Personals, news items, notices of meetings of societies, conventions, etc., will be received up to the twenty-second of the month preceding issue.

The Syracuse Academy of Science will entertain the American Microscopical society during its annual meeting, which this year is held in Syracuse, August 30th to September 1st, inclusive. The sessions of the society will be held in the fine new building of the College of Medicine, Syracuse University. As Syracuse is so situated as to be easily accessible by rail from all directions, and has excellent hotel facilities, a large attendance is expected. The committee expects to place at the disposal of the society a special dining room at one of the hotels. This feature will contribute greatly to the social enjoyment of the members. We are informed that the titles of a large number of papers on practical subjects have been handed in. More are solicited. Titles may be sent to Dr. V. A. Moore, Cornell University, Ithaca, New York, or Dr. William C. Krauss, 371 Delaware avenue, Buffalo, New York.

Journal of Applied Microscopy.

VOLUME I.

AUGUST, 1898.

NUMBER 8

Some Notes Concerning the Histological Laboratory of the Howard University, Medical Department, Washington, D. C.

The city of Washington affords especial facilities for the study of medicine and the teaching of laboratory courses which bear directly upon the study of medicine. Here are the large collections of books, contained in the Army Medical Museum and Library and in the Library of Congress, all of which are accessible, between the hours of 9 to 4 daily, for the use of students. In the library of the Surgeon General's office are about 160,000 volumes, and so complete is the collection that the student carrying on any particular line of research can find literature exhausting the subject almost up to the date of writing. In the National Museum and Smithsonian Institution and Fish Commission, the student in comparative histology and pathology can acquire material covering almost every subject to aid him in his work, and those who are interested in microscopical work as applied to botanical subjects can have the same facilities afforded at the Department of Agriculture, so that the means of acquiring exhaustive literature and the necessary material for the furthering of scientific work in any line of research are at hand.

A large number of students who are acquiring a medical education in Washington are employed during the day in one pursuit or another, and very commonly in the service of the Government, and for that reason the medical colleges with but one exception have adopted evening sessions for lecture work and laboratory courses for the special accommodation of these students. They do not, therefore, enjoy the advantages which students have in most other cities, from the fact that they enter upon their work after they have completed the pursuits of the day, and of course are not so fresh and in as good condition for study as the student would

be who has his entire time at his disposal. Nevertheless, a great amount of scientific work is conducted under these conditions, and the students' average compares very favorably with those whose time is more conveniently arranged.

In the medical department of Howard University the course covers four years.

The histological course, dealing strictly with the normal human subject, occupies the student the first year; but one night a week is allowed for this, and an average amount of time of three hours per night. The student comes to this course early in the evening, having no prior lecture work, and is, therefore, better fitted for the study than was formerly the case when the work was conducted for the fourth year students.

The Howard University Medical Department is situated on the grounds of Freedmen's Hospital, having an average admission of five thousand cases per year. In almost every instance "death" cases are carefully posted, giving a vast amount of material of the utmost benefit to the histological and pathological laboratory. The student has the benefit, too, of material which can be secured perfectly fresh, and which represents a great variety of pathological conditions, so that during the writer's fifteen years' service in connection with this institution, he has acquired in the neighborhood of twenty-five hundred well identified preparations, embracing both normal and pathologic histology.

The histologic laboratory occupies a well lighted and well ventilated room, immediately under the surgical amphitheater. The room is about forty-eight feet long by twenty-two feet wide, and the adjoining room, used as a private laboratory or laboratory of preparation, twenty-two by twenty-eight. In the

larger room, devoted entirely to students' work, are placed two rows of tables, accommodating sixteen students each, while an additional table is arranged at the end of the room to accommodate eight students. While the tables so arranged will accommodate forty students, it is the writer's opinion that it would be to much greater advantage and to the increased benefit of the student if but one-half of this number were provided for in a room of this size. However, the time allowed for the course and the limited number of hours nightly make it absolutely necessary to instruct the entire class at one session instead of dividing it into sections. Each student is provided with a space sufficient for the ordinary reagents which are required in the work of finishing preparations. In addition the students' laboratory is supplied with twenty-five compound microscopes, dissecting microscopes, and microtomes of the most improved pattern.

While it is impossible to adopt a rigid plan of work or a program to be followed yearly in the teaching of normal histology, which embraces so many and varied methods, we believe that a plan which instructs the student in the widest scope of work with the least expenditure of time is the better one. The scheme we have adopted here, and which seems to meet the requirements of this class of students best, is the one that acquaints them in the first place with the construction and application of the instruments, methods more generally followed in normal histologic work, and a careful examination of the tissues in the order as laid down in the most approved text-books on histology. Inasmuch as few students have had any prior instruction in the use of the microscope, it has been found necessary to devote a few evenings to the consideration of the instrument, its optical parts, mechanical parts, methods of lighting, consideration of the construction of objectives and eyepieces, optical imperfections, magnification, micrometry, and photography. About three or four evenings are devoted to a demonstration of the methods of preparing tissues and organs for examination, fixing and hardening, preservation of tissues, decalcifying, embedding, section cutting, staining, application and methods of staining, special methods of staining the nervous system, injections, and the examination of fresh tissues and fluids. After this, the study of the cell and elementary tissues and karyokinesis. Then, in regular order, the amount of time allowed to each subject dependent entirely upon the progress of the class or section, the student will take up the study of:

Blood.

Epithelial tissues—varieties; endothelium, distribution.

Connective tissues—forms; cellular elements; intercellular; mucoid; tendon; elastic; adipose; cartilage; bone.

Muscular tissues—non-striated; striated—structure and distribution of each; cardiac muscle.

Nervous tissues—nerve cells (particular methods of staining adopted to demonstrate these); nerve fibers; medullated and non-medullated nerves; ganglia.

Mucous membranes—structure of these, and the glandular structures in connection with them.

Digestive tract—mouth; salivary glands; teeth; tongue; oesophagus; stomach; intestines; glands; liver, pancreas.

Urinary organs—kidney; bladder.

Male Reproductive organs—testicle, spermatogenesis; prostate.

Female Reproductive organs—ovary; uterus; vagina; mammary.

Respiratory organs—trachea; bronchi; lungs, pleura; thyroid.

Skin and appendages—skin; nails; hair; sebaceous glands; sweat glands.

Central nervous system—membranes; spinal cord; medulla; pons; cerebellum and the cortex.

In addition, the organs of special sense are studied.

This scheme, of a course adapted as the author thinks best to the requirements of a medical class, is modified from time to time, dependent upon the material at hand best suited for demonstrating the particular subject. It is almost impossible, for these and other reasons, to follow an uninterrupted course, if it is the teacher's aim to present the student with the most typical material illustrating the normal subject, but the opportunities in connection with hospital work, for acquiring fresh material, are so great that it is rarely the course lacks demonstration for want of material suitable to the purpose.

In order to better impress upon the student the essential characters of human histology, the writer from time to time employs tissues of the lower animals where in his judgment the character of the cells or arrangement of parts of the organs will serve best to impress the student with the appearances of the normal human subject.

On account of the limited time and the lateness of the hour when the laboratory course begins, we have thought it best to prepare as far as possible all material which the student uses in his de-

monstration and study, so that time may be saved for the student, and what he would have to devote to the preparation of the tissues he can turn to better account in the study and comparison of them. It is true that the student loses much in the matter of technique, which would be of service to him, but opportunity is given just as far as possible outside of the hours devoted to the course for the student to acquire this knowledge. Work is continually being carried on in the private laboratory in the preparation of tissues for students' use, and as far as possible the students are encouraged to lend assistance here and to acquire as comprehensive a knowledge as possible of the technique. Every laboratory worker knows that the time devoted to a first year's medical course would in itself be hardly sufficient for the most ambitious student to acquire a thorough knowledge of technique. It would be useless then and a waste of valuable time of the student to burden the course with this part of the subject. The student undoubtedly turns to better account his limited time in the faithful study of the well prepared and well identified tissues and structures which are furnished him.

It might not be out of place here to mention the general scheme followed in the laboratory course, which has been adopted after a dozen years of laboratory teaching, as it seems most consistent with the saving of time and the accuracy of the work necessary for the guidance of the student. The methods designated in the preparation of the various tissues used in histological demonstration are by no means exhaustive, but serve best in the writer's opinion to give the beginning student a general backbone method for pursuing his work and placing him in a position from which, as the occasion may require, he can enlarge upon and follow out the numerous methods so exhaustively laid down in the text-books.

In the beginning of the course the student is taught the general methods of the preservation of histological material, the examination of the tissue in the fresh state, examination of tissues in normal fluids and, wherever it is possible, although it is not directly connected with the histological subject, attention is drawn in the matter of dissection to all points which may be of interest and benefit to the student in connection with physiological work which he is pursuing during the same year. Considerable opportunity is allowed the students who will avail themselves of it, for actual post-mortem work, as the material in a hospital offers many advantages and occasions for this class of teaching. Par-

ticular stress is laid upon the methods of preservation and the fluids best adapted to the preserving of tissues, and the student is well impressed with the necessity of securing material in as near as possible a perfect or normal state.

The methods of dissociation and corrosion are taught thoroughly, as well as the methods of decalcification. The hardening of tissues and the fixing are particularly dwelt upon, inasmuch as the results are so much dependent upon the proper conduct of the work during these stages. The methods more commonly employed in the laboratory at the present time are the "alcohol" and "formalin." Many of the more useful "formula" solutions are taught, and their special application pointed out to the student. Where, however, a considerable amount of work is to be done in a very limited time, I have thought it best to impress the student with the use chiefly of the "alcohol" and "formalin," these offering on the whole the best results and requiring less expert work on the part of the student in their preparation. Section work is taught chiefly by the "paraffin" method, with exceptions, the writer finding it far more convenient and giving much better results. The "celloidin" method is taught also and demonstrations given of its use in particular instances where it is found by experience to be best applied.

The making of sections which are to be supplied for students' use has necessarily been conducted by myself or my laboratory assistant. It would be of the greatest advantage if every student could have the opportunity of doing personally this part of the work, but the lack of prior training on the part of the student in the use of the delicate apparatus, and the injury to knives as well as instruments, rather forbids the individual work in this line. Furthermore, the work being done by expert microtommists, the students get uniform sections each of which has been especially cut to demonstrate to the best advantage the particular subject.

The technique of staining has been reduced to a few of the more generally used stains, as we are of the opinion that a few methods of staining well learned give far better results with the beginning student than a vast number which so many experiment with and fail to make successful. Haematoxylin, eosine, carmine, and a few specially adapted to the staining of nervous structures represent the ones in continual use. Many preparations in the laboratory which have been stained by special methods to demonstrate certain points are at the command of the student, and serve as a good illustration of the special tech-

nique and staining. Methods of clearing, fixing sections to the slides, general methods of mounting, and the more useful methods of injection are demonstrated fully.

In the histological laboratory the class averages about forty students yearly, and time is a matter of great consequence. It might not, therefore, be out of place to state very briefly the general method of procedure in the preparation of a specimen, from the time the student secures it from the operating room until it reaches the completed state. Of course, this could only apply to the ordinary histological specimen, and is in no wise intended to cover every tissue which the student would require for study. It is absolutely necessary, of course, in order to demonstrate certain points, that special methods be employed, but for the general methods of procedure—hardening, fixing, staining, and mounting—the work is conducted in about this way.

After the specimen is received the student will immediately place it in the hardening or fixing fluid which he has been instructed is most suitable for that particular kind of tissue, following the general directions which apply for reducing the specimen to a suitable size and sectioning it so that the most suitable plane for study will be presented, first attaching a numbered tag to it. Every specimen so received has attached to it a small tag which is made of pure

stand any of the hardening, fixing or corrosion fluids, and the numbers upon them will never be effaced. Furthermore, if it is a matter of economy and sufficient care is taken to avoid confusion in duplicating numbers, they can be used repeatedly. In the writer's case, where the requirements in the laboratory are large, they are not used a second time. After a tag is so prepared and numbered, you can, with an ordinary needle, perforate the tin and stitch the tag securely to an end of the specimen or the histological block, where it will not interfere with the sectioning. Of course, in some cases, and this would apply particularly to embryological work, it would not do to perforate any part of the specimen. In that case the tag might simply be carried with the sample specimen through the various reagents and preserved with the paraffin block when it has reached the final stage. A specimen so numbered at the very beginning, the tag securely fastened to the block, enables it to be identified for all time, and no matter how many specimens one is preparing at the same time, they can be placed together in one fluid or another, or in the jars of the paraffin bath, and no confusion result. Every specimen, after it receives its number, is recorded upon index cards, which for convenience, I should say, should be five inches by three inches. These I have had already printed, as shown by the accompanying exhibit.

1658	[SUBJECT.] <i>Liver</i>
CLASS	<i>Normal</i>
RECEIVED	<i>Freedman's Hospital.</i>
FROM	<i>A. Ancey</i>
HARDENED	<i>Alcohol</i>
EMBEDDED	<i>Paraffin</i>
STAINED	<i>Haematoxylin</i>
INJECTED	<i>Carmine Goldstein</i>
SERIES	<i>36</i>
REMARKS	<i>Injection rather good.</i>

Index Card.

thin sheet tin, about one inch long by one-fourth inch wide. These are marked out of a sheet and then the numbers are stamped upon them with metal dies. If it is preferred, and less time will be required in preparing them, the number can simply be scratched upon them with a sharp instrument, and will be quite as lasting. It is found, after using these tags for many years, that they will with-

If the specimen is known to be a normal one (pancreas, for instance), it would be catalogued under the subject which would appear in the head line. The line headed "Class" is intended for the convenience only of dividing my collection of "normal histology," "comparative histology," "pathology" and "tumors." The other heading "Received" is simply to indicate the source from which

the specimen is derived, as from a particular hospital, laboratory or institution. The heading "From" more particularly indicates the fact that it is derived from an individual. The succeeding headings: "Hardened," "Embedded," "Stained," and "Injected" serve simply the purpose to note just how the specimen has been treated, or just what methods of preparation have been applied. "Dupl. Series" serves to note the fact that additional blocks of the same material have been made, the number of them in the "reserve" series, or the fact of their disposition by exchange or otherwise. "Remarks" serve for any additional matter which the collector may care to note concerning the specimen. The space in the upper left-hand corner has been left for noting the number of the specimen.

For years the writer kept this index catalogue in book form, beginning his record with a normal histology index and a general pathological index, and then simply noting after each subject the number corresponding to the number on specimen. After half a dozen years' use he found this to be troublesome on account of the difficulty of bringing all specimens in a class together, and any index short of a card index will fail to do this. With each specimen indexed upon a single card, no matter how many hundreds or thousands one may accumulate, they can readily be sorted or classified so that one can see at a glance just what he has in a particular subject, and with the cards in a group readily turn from the card index to the specimens arranged numerically in the cabinet, and secure the desired preparation.

A cabinet of "Type slides" is in course of preparation now. This will consist of a section from each one of the accumulated preparations, arranged in the cabinet in corresponding order to the index card catalogue, and will serve to demonstrate at a moment's notice the features of any desired subject.

Another point I would wish to draw attention to, as a matter of laboratory economy, would be in the way the preparations are cared for after they have been properly embedded. It was always a matter of difficulty, until a plan was suggested of arranging the specimens in uniform boxes, to find at a moment's notice any desired specimen. The most convenient means, in my opinion, of keeping a large collection, is to place them as soon as the blocks are embedded, and after they have been examined and found suitable for sectioning, in small carton boxes 45x30mm., which are commonly used by druggists for containing small vials. These are extremely cheap,

neat, and remarkably convenient for this purpose. A specimen that has been embedded with the tag attached to it is now carefully freed from the excess of paraffin, allowing just sufficient to protect it when clamped in the jaws of the microtome, and the metal tag warmed slightly and pressed into the paraffin at the bottom of the block. This is a point worthy of attention, from the fact that many times when blocks have been removed from the carton boxes for the purpose of making sections, and with a number of these in use at a time, it allows a possibility of displacing or mistaking one preparation for another, and in that way getting into the wrong boxes when they are placed away in the cabinet. With the tag so impressed in the paraffin they rarely become detached and of course prevent the possibility of error of this kind. When placed in these uniform boxes they make a neat arrangement in the shallow drawers of the cabinet. The number is noted upon the top of the box, and as they stand side by side in the drawers one can see at a glance the preparation he wants.

When so much time has been devoted to the acquiring of valuable histological material, for the proper preservation of it, and the many stages necessary to make it suitable for study and future use, it would seem to be of the utmost importance to use every care in the proper classification and identification of that material. The method I have just described has given great satisfaction, and has been in use for some half a dozen years without the loss of a single preparation.

The student has been instructed in all the methods looking to the proper preservation of sections which are generally used in placing the section on the slide and preserving its general relationship. After many years' experiment in this particular part of the work, using the collodion, gum, and other methods of the same nature, all of these have been abandoned, and the water method or water and alcohol used entirely in their stead. It was found that too much time was lost in smoothing out sections which had been placed upon the collodion and clove oil or albumen fluids, and that the results were upon the whole anything but satisfactory. The collodion method, while it overcomes many of the disadvantages experienced by a new student, such as properly smoothing out a section, is found less satisfactory than paraffin. It has been the writer's practice, therefore, to prepare in advance of the class work an average of about sixty preparations of any one subject and have these all fixed upon the slides ready for the students' use. It has been the

custom to issue to the student five or six preparations illustrative of the subject assigned for that practicum on a stated evening. For instance, if the liver was the subject that the student was engaged upon, he would be given a preparation showing a single staining of the normal structure, one showing a double staining of the same structure, one showing the vascular areas as mapped out by injection processes, and another demonstrating the combined effects of staining and injection; in addition to these, two or three preparations illustrating the same subject (that is, the liver) in comparative histology. With a class as large as forty students, it is not a difficult matter to prepare fifty or sixty such preparations, fixed upon slides and ready for staining and finishing on the part of the student. The work for an entire class, when the material is at hand, properly embedded, can be thoroughly accomplished in from two to three hours' time.

The difficulties experienced in using the albumen and gum methods were these: first, that the sections were with difficulty floated out evenly upon the solutions, causing overlapping of the sections and interfering with a perfect field; secondly, from the amount of stain which the albumen or gum would retain, even when used in the most dilute solution. To overcome this we gradually reduced the ordinary percentage of the solution from one-half per cent. to one-tenth per cent., and yet met with the same interference on the part of the various staining solutions. It was then suggested to use a purely aqueous solution, which was tried with marked success. Since that time (about four years ago) distilled water alone has been employed for fixing sections to slides. This overcomes the difficulties previously alluded to, such as the interference of staining and the smoothness of the section. For the convenience of the laboratory workers, who are concerned with the making of a large number of preparations, as many perhaps as four hundred for the demonstration of any single practicum, I would recommend the following process: using the ordinary water pan bath, which will accommodate twenty-four slides, the slides are in the first place thoroughly cleansed from any greasy matter, and this is of the utmost importance in order to allow of the even distribution of water upon the slide. The pan is filled with the twenty-four slides, distilled water from an ordinary pipette or dropper is floated upon them, in quantity sufficient to accommodate the size of the sections. As fast as the sections are removed from the knife they are placed under the distilled water, and as

soon as the tray is filled, placed over a water bath in a temperature just under the melting point of the paraffin. This point is of the greatest importance, and must be carefully looked to. If the temperature rises above the melting point of the paraffin, the relationship of the tissues will be entirely destroyed, as the paraffin gradually separates them. It should be just sufficient, therefore, to float out the entire tissue and embedding mass evenly on the surface of the water, and as soon as this point is reached, the tray should be removed from the bath. It is well not to attempt to arrange the sections symmetrically upon the slides until they have cooled slightly. If done too early, the paraffin, being too soft, will adhere to the needle point or instrument used for the purpose, and the work will be very much retarded, but if allowed to cool slightly as many as fifty or one hundred preparations can be arranged upon a single slide of sufficient size to accommodate them without any danger of sticking together or being disarranged with the instrument used for arranging.

As soon as the preparations are arranged in the proper position in which it is desired to retain them for future use, the slide is tilted slightly, the excess of water allowed to drain away and stood up in racks for thorough drying. The only disadvantage in this method of which the writer is aware is that the preparations can not be immediately used, but must be thoroughly dried, in order to insure perfect results.

The other methods more commonly employed (collodion, for instance) allow of the immediate continuance of the work. The best recommendation of the method here described for work of a serial character, to my mind, is that in the making of a series of about sixteen hundred preparations, every one of which was placed upon a single slide, there was a loss of but two preparations in the entire series, not one of them coming off in the various fluids used in their further preparation, such as alcohol, water, stain, decolorizing fluid and mounting fluid; we believe that there is less distortion, less shrinkage or swelling resulting from a method of this character than is liable to be the case where the gums or albumens are employed, and as the aim is as far as possible to keep the tissues in a perfectly normal condition and relationship, we should, after many years' experience, recommend this as a most suitable and advantageous method.

J. MELVIN LAMB, M. D.

Please forward your name for the Journal Microscopical Directory.

A Black Finish for Table Tops.

A satisfactory finish for a laboratory table, especially in Chemistry and Biology, is highly desirable. Where the microscope is used a black surface is obviously preferable. It is also desirable to have a finish that can resist the action of the common chemicals which either stain or corrode the ordinary wood tops, otherwise they soon become stained and unsightly in appearance.

A slate or tile top which answers the above demands is expensive in its original cost and also as a destroyer of glassware, and therefore beyond the reach of many. Wood tops, when painted, oiled, or paraffined, present strongly objectionable features. It is possible, however, to dye wood, by a process resembling the "anilin black method" of commerce, cheaply and extremely satisfactorily.

Nearly two years ago, in finishing a table for student use in the bacteriological laboratory of the University of Wisconsin, Prof. Woll, of the Experimental station, recommended the process of ebonizing which he had seen in use in several laboratories in Copenhagen, and it is the directions he secured there which are given below. While the table was being treated my attention was called to an article which was written shortly before by Prof. Dr. Julius Wortmann* describing the method used in Denmark. Prof. Barnes,† in reviewing this article, briefly described the process as used here as well as that used in the Danish laboratories, although both are essentially the same.

The following solutions are required:

I.

125 grams of copper sulphate,
125 grams of potassium chlorate,
1,000 grams of water.
Boil until salts are dissolved.

II.

150 grams of anilin hydrochlorate,
1,000 of water.
Or, if more readily procurable,
120 grams of anilin oil,
180 grams of hydrochloric acid,
1,000 grams of water.

By means of a brush apply two coats of solution No. I while hot, the second coat as soon as the first is dry. Then apply two coats of solution No. II and allow the wood to thoroughly dry. A coat of raw linseed oil is next applied. It is best to use a cloth instead of a brush so as to get only a very thin coat of the oil. The desired amount of polish is now given the wood by rubbing in the oil. In the treatment with the oil the deep black color is partially brought out, although this does not uniformly appear until the

table has been thoroughly washed with hot soap suds. This takes out the superfluous chemicals.

The finish thus secured is an ebony black which is permanent and very highly resistant to the action of chemicals, such as acids and alkalies, even concentrated sulphuric acid having little or no effect if quickly washed off.

The anilin dye stains may also be readily removed by the application of some solvent, as alcohol.

It is not only possible to treat new table tops in this way, but old ones take nearly as good a finish. In this case the old oil or paint is planed off and the surface is treated as new wood.

The tables in the bacteriological laboratories here are practically in as good condition to-day, after use by students during two school years, as they were when finished.

To keep the surface constantly in good condition it is only necessary, after a thorough washing, to rub on a light coat of oil. The expense is trifling. The cost of both solutions, in the quantities given above, will not be over fifty cents, and this amount will cover at least ten square yards of surface.

W. D. FROST.

Instructor in Bacteriology, University of Wisconsin, Madison, Wisconsin.

*Bot. Zeitung, 54, 326.

†Bot. Gaz. 24, 66.

Celloidin Imbedding.

The following method of celloidin imbedding has been employed in this laboratory for the last two years and has given excellent satisfaction. The method is employed at the University of Toronto, Mr. E. C. Jeffrey, B. A., the lecturer in botany, being responsible for many details. For woody stems, any particularly hard tissue, seeds of Gramineae, etc., it gives excellent results. Briefly, the different steps are as follows:

The tissue is fixed in a saturated solution of corrosive sublimate in absolute alcohol.

Transferred to alcohol* plus a few drops of a strong solution of iodine, for twelve hours.

The iodine is then thoroughly washed out in several changes of alcohol, the last two changes being absolute alcohol.

Changed into equal parts of absolute alcohol and absolute ether for twelve to twenty-four hours.

Thence to two per cent. celloidin (Scherling's shredded, dissolved in equal parts of absolute alcohol and absolute ether, or two parts of ether to one of alcohol) for three or four days.

Then passed through four per cent. (two days), six per cent., eight per cent., ten per cent., twelve per cent., and lastly fourteen per cent., each one day.

For hard tissues, especially woody stems, it is advisable to wire the corks in the bottles (two ounce saltmouth are the most convenient) containing the celloidin solutions, and place them in the paraffin bath at 52°C.

The celloidin deteriorates after being used two or three times in the bath.

From fourteen per cent. celloidin the pieces are taken out and dropped in chloroform, where they remain for four to twenty-four hours, depending on the size of the piece.

The final transfer is from the chloroform to equal parts of glycerine and alcohol. In this mixture the tissues seem to keep indefinitely, and they can be used as required. I can recommend this method for class material. Very thin sections can be readily cut owing to the complete infiltration of the specimen.

F. C. HARRISON.

Agricultural College, Guelph.

*The alcohol used is about ninety-four per cent. It contains a little methyl alcohol.

The Use of Modeling Clay in the Study of the Fish Embryo.

In the study of the embryology of the fish, the manner of growth of the germ ring, and the formation of the embryo from it, are difficult to demonstrate to

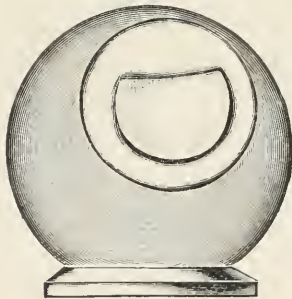

Fig. 1.

Showing complete germ ring and early formation of the embryonic shield.

the student by the ordinary drawings. To overcome this difficulty, I have constructed a series of models showing embryo. Wooden balls (at the suggestion of Professor Morrill, I used croquet balls) were covered with a thin layer of modeling clay, and upon this was built, with the same material, models of the embryo. The methods employed will be seen

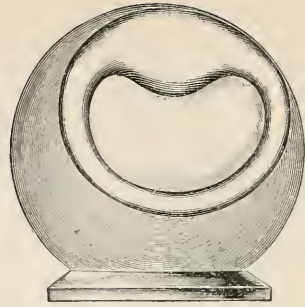

Fig. 2.

Later stage in the formation of the embryonic shield.

from the accompanying figures. The clay sticks easily to the surface of the wooden ball and can be made into a very thin layer, which can be colored if desired. Upon this are modeled the embryos of various stages. I have colored the germ

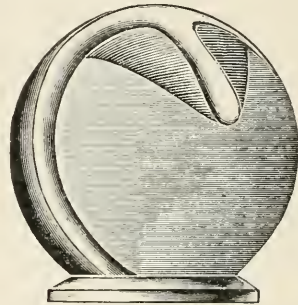

Fig. 3.

Embryo forming, germ ring half way around the yolk.

ring and embryo a deep yellow and the portion inside the ring a lighter yellow, while the thin layer of clay covering the remainder of the ball is left uncolored. Thus the uncolored area represents, in this case, the periblast, the light yellow

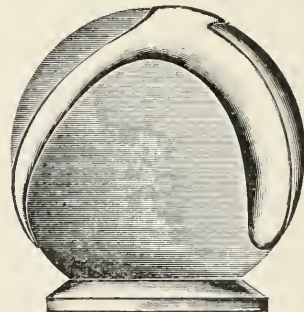

Fig. 4.

Embryo nearly complete, germ ring two-thirds around yolk.

the ectoderm, and the deeper yellow the germ ring and embryo. Modifications of the process can be made, and many such modifications will undoubtedly suggest themselves to anyone sufficiently interested to attempt the work for himself.

A. L. TREADWELL.

Wood's Holl, Mass.

American Microscopical Society.

The twenty-first meeting of the American Microscopical Society will be held in Syracuse, N. Y., at the College of Medicine, Syracuse University, August 29th to September 1st, inclusive.

The officers for this year are:

First Vice-President, Dr. Moses C. White, Yale Medical School.

Second Vice-President, Dr. V. A. Moore, Cornell University.

Secretary, Dr. Wm. C. Krauss, Niagara University.

Treasurer, Magnus Pflaum, Pittsburg, Pa.

Owing to the death of the President, Prof. D. S. Kellicott, Dr. Moore will act as president during the meeting.

The local committee, of which ex-President Dr. A. C. Mercer is chairman, has completed arrangements for the entertainment of the society, and the following interesting programme has been prepared. It will be noted that the papers are on practical subjects:

Monday, August 29:

8.00, P. M.—Meeting of the Executive Committee in the assembly room of the Vanderbilt, Washington street, corner Warren street.

Tuesday, August 30:

9.00, A. M.—Meeting of the Executive Committee in the Library at the College of Medicine, 307-311 Orange street.

9.00, A. M.—Exhibits of microscopes, laboratory apparatus, etc., in the Men's Study, College of Medicine.

10.00, A. M.—(1) Address of Welcome, by Prof. Charles W. Hargitt and Prof. John Van Duyn, in Lecture Room A, College of Medicine.

(2) Response, by the acting President, Prof. Veranus A. Moore, of Cornell University.

(3) Election of new members.

(4) Biography of President D. S. Kellicott, by Prof. A. M. Bleile, M. D., Columbus, O.

(5) Biographies of Professor Wm. A. Rogers and Professor Henry C. Coon, by Prof. S. H. Gage, Ithaca, N. Y.

(6) A Method for Preparing Nucleated Blood in Bulk for Class

Demonstrations, by Dr. T. E. Oertel, Milledgeville, Ga.

(7) Special Structure Features in the Air Sacs of Birds, by Mary J. Ross, A. B.

(8) A Report of a Student's Work in the Micrometry of the Blood Corpuscles of Individuals of Different Nationality, by Prof. Moses C. White, New Haven, Conn.

(9) The Teaching of Correct and Definite Methods in the Use of the Substage Condenser (Demonstration), by Dr. A. Clifford Mercer, Syracuse, N. Y.

1.30, P. M.—Exhibits of microscopes, laboratory apparatus, etc., in the Men's Study, College of Medicine.

1.45, P. M.—Meeting of the Executive Committee in the Library, College of Medicine.

2.00, P. M.—General meeting in Lecture Room A, College of Medicine.

(1) Histolysis of the Toad Tadpole's Tail, by B. F. Kingsbury, Ph. D., Ithaca, N. Y.

(2) The Use of Picro-carmin and Alum-carmin, by B. D. Myers, Ph. B., Ithaca, N. Y.

(3) A Rapid Staining and Washing Apparatus, by C. M. Mix, A. B., Ithaca, N. Y.

(4) Photomicrography with Opaque Objects, by Mr. Wm. H. Walmsley, Philadelphia, Pa.

(5) The Business Management of Laboratories, by Mr. L. B. Elliott, Rochester, N. Y.

(6) Microscopic Examination of Legal Documents, by Dr. Geo. E. Fell, Buffalo, N. Y.

(7) Some Laboratory Apparatus for Histology, by Prof. S. H. Gage, Ithaca, N. Y.

(8) An Occurrence of Albino Eggs of the Spotted Salamander, *Ambystoma punctatum*, L., by Mr. Horace W. Britcher, Syracuse, N. Y.

(9) Suspension of Photomicrographic Apparatus to Avoid Vibration (Demonstration), by Dr. A. Clifford Mercer.

8.00, P. M.—Introduction, by Prof. Chas. W. Hargitt, President of the Academy of Science. The annual address, by acting President, Prof. Veranus A. Moore, in the new hall of the University business building, Vanderbilt Square, opposite the Vanderbilt.

9.00, P. M.—Informal reception only for members and delegates from out of town, Citizens' Club, University business building.

Wednesday, August 31.

9.00, A. M.—Meeting of the Executive Committee in the Library, College of Medicine, 307-311 Orange street.

9.00, A. M.—Exhibits of Microscopes, laboratory apparatus, etc., in the Men's Study, College of Medicine.

10.00, A. M.—General meeting in Lecture Room A, College of Medicine.

(1) Election of new members and of a nominating committee.

(2) Notices of Some Undescribed Infusoria from the Fauna of Louisiana (being a continuation of a paper read before the Society in 1897) by Mr. J. C. Smith, New Orleans, La.

(3) Experiments in Feeding Some Insects with Cultures of Comma, or Cholera, Bacilli, by Dr. R. L. Maddox, Hon. F. R. M. S., etc., Southampton, England.

(4) Questions in Regard to the Diphtheria Bacillus, by Dr. M. A. Veeder, Lyons, N. Y.

(5) Means and Methods for Giving Instruction in Bacteriology, by Raymond C. Reed, Ph. B., Ithaca, N. Y.

(6) What Shall be Taught in a Short Course in Bacteriology? by Prof. Veranus A. Moore, Ithaca, N. Y.

(7) The Resistance of Certain Species of Bacteria in the Milk Ducts of Cows, by A. W. Ward, B. S., Ithaca, N. Y.

(8) The Comparative Value of Different Methods of Plankton Measurements, by Prof. Henry B. Ward, Lincoln, Neb.

(9) Work Done on Lacustrine Biology, 1896-1898, by Prof. Henry B. Ward, Lincoln, Neb.

1.30, P. M.—Exhibits of microscopes, laboratory apparatus, etc., in the Men's Study, College of Medicine.

1.45, P. M.—Meeting of the Executive Committee in the Library, College of Medicine.

2.00, P. M.—General meeting in Lecture Room C, second floor, College of Medicine.

Working Session:

(1) The Electric Projection Microscope in Histology with a New Departure in Objectives (Demonstration), by Prof. Moses C. White, New Haven, Conn.

(2) Demonstration of Physiological Apparatus, by Prof. Gaylord P. Clark, in the Physiological Laboratory, second floor, College of Medicine, Syracuse, N. Y.

(3) New Simple Form of Serum Inspirator (Demonstration), by Dr. Wm. H. May, in the Pathological and Bacteriological Laboratory, third floor.

(4) Diphtheria Bacilli Testing for a City Board of Health (Demonstration), by Dr. Wm. H. May, Bacteriologist for Syracuse, in the Pathological and Bacteriological Laboratory.

(5) Johnson-Widal Test for Typhoid Fever (Demonstration), by Dr. Wm. H. May, in the Pathological and Bacteriological Laboratory.

(6) Recent Discoveries in Blood Pathology (Demonstration), by Dr. George B. Broad, Syracuse, N. Y., in the Pathological and Bacteriological Laboratory.

(7) Microtome Sectioning, by Dr. Theodore J. Kieffer, Syracuse, N. Y., in the Histological Laboratory, second floor.

(8) The New Minot Microtome (Demonstration), by Dr. I. Harris Levy, Syracuse, N. Y., in the Histological Laboratory.

(9) Demonstration of Specimens, by Dr. Theodore J. Kieffer, in the Histological Laboratory.

(10) Red Blood Corpuscles of Necturus, (?) Karyokinetic Figures (Demonstration), by Dr. I. Harris Levy, in the Histological Laboratory.

7.15, P. M.—Arranging microscopes for soiree.

8.00, P. M.—Soiree in the laboratories of the College of Medicine.

Thursday, September 1, 1898.

9.00, A. M.—Meeting of the executive committee in the Library, College of Medicine.

9.00, A. M.—Exhibits of microscopes, laboratory apparatus, etc., in the Men's Study, College of Medicine.

10.00, A. M.—General meeting in Lecture Room A, College of Medicine.

(1) Election of new members.

(2) Reports of officers.

(3) Report of nominating committee.

(4) Election of officers for ensuing year.

(5) General business.

2.00, P. M.—Carriage ride—to the University Campus, the Syracuse State Institution for Feeble Minded Children (where a demonstration of methods used will be made by the Superintendent, Dr. James C. Carson) and to the reservoir of the city water works (where the Superintendent, Mr. William R. Hill, will guide the party).

Evening—Freedom of the Citizens' Club.

In addition to the proceedings of the society, the laboratories of the Syracuse University will be found of great interest, being exceptionally well equipped and arranged. The physiological laboratory is perhaps the most thoroughly equipped for student work of any in

America and contains many pieces of apparatus of original design by Prof. Gaylord P. Clark. The faculty of the college has arranged to have all laboratories open for inspection during the meeting.

Microscopic and Microscopical.

These two words represent two distinct ideas which no one word can express with precision; and, now that some microscopical writers are falling into the growing fashion of dropping the final "al" after "ic," it seems wise for microscopists to deliberately decide whether they will consent to drop in a word an "al" which they want, because some other specialist drops one that he doesn't want. Are microscopical authors so microscopical in their self-possession and literary prudence as to be carried away by a fad, however, commendable it may be in some other cases? We wish to mention a very minute object, so small as to suggest, either literally or figuratively, the necessity of using a microscope to see it, and we describe that object as microscopic. We wish to speak of an object as pertaining or related to the science or art of microscopy, without regard to its size, and we call it microscopical, though it might be absurd to call it small (microscopic). Thus, the microscopic dictionary and the Royal Microscopical Society both are microscopical, though about as far as possible from microscopic. While a desmid or a bacillus is evidently microscopic as well as microscopical, the former term in this case includes the latter. A tiny book, however, which the writer bought in Paris last summer, a regularly printed and well bound volume of several hundred double-column pages, something like an inch square and perhaps one-fifth inch thick (speaking by guess, as the book is not at hand at the time of this writing), is microscopic enough to suit almost anybody, but not microscopical, as it has nothing to do with microscopy, being interesting solely as a general or a bibliographical curiosity and not by reason of its reading matter, which can be made out only with a lens. The Journal of Applied Microscopy, which has made such a brave start, is a microscopical paper; let us hope it may never dwindle to a microscopic one. To the writer, who has been especially interested in this question, having been, to say the least, one of the first, many years ago, to use these two words, and to urge their use, not indifferently as synonyms, but with a strict application in the two senses indicated here, it seems like anything but intelligent re-

form to drop one of the words, now that they have come into very general and successful discriminative use, and to leave ourselves with only a single word with which to express two distinct ideas, retaining the delightful privilege of taking a chance of being misunderstood (either honestly or in perversity) or of adding an awkward explanation every time to indicate in which of its senses the retained word is used. If the journals could feel justified in officially adopting for their own pages the precise use of the two words, just as important periodicals adopt without hesitation their own standards in cases of disputed spelling or punctuation, it would go far toward settling this matter right, and, what is perhaps harder, keeping it settled; for some blessed soul is sure to turn up, after a few years, thinking that he can make the world better than it grew, by tinkering with something about which he does not even know that it was settled, on good grounds, long before.

R. H. WARD.

Troy, N. Y.

Cleaning Old Slides.

A description of a simple and effective method of cleaning microscope slides which have been used, may be welcomed by those who have been bothered by the complex methods described in various technical works.

Glass slides should be dropped into a strong aqueous solution of "concentrated lye" kept in a large battery jar, and when a goodly number of slides have been accumulated pour off the lye and wash the slides in tap water.

The balsam or other mounting medium, object, and cover slip will be removed by the slightest rubbing with the fingers, and the slides perfectly cleansed by a second rinsing in tap water.

The slides may then be wiped and kept in a box, or, better, kept in a small jar, partly immersed in eighty per cent. alcohol and wiped dry just before using. Lye solution of sufficient strength and yet not strong enough to attack the glass, may be prepared by dissolving, in a liter of hot water, twenty-five grams of the concentrated lye commonly sold in the shops conveniently packed in tin cans.

E. R. LARNED, M. D.

Joliet, Illinois.

Rotifers infusoria and other minute rapidly moving forms can be kept quiet by mounting under the cover glass, in the water containing them, a few strands of cotton wool or by adding a very small quantity of ether to the water.

Journal of Applied Microscopy.

Issued Monthly from the Publication Department
of the Bausch & Lomb Optical Co.,
Rochester, N. Y.

L. B. ELLIOTT, EDITOR.

Address all communications to
PUBLICATION DEPARTMENT,
Bausch & Lomb Optical Company,
ROCHESTER, N. Y.

One Dollar per Year. To Foreign Countries, \$1.25
per Year.

Entered at the Post-office, Rochester, N. Y., as second-class matter.

AUGUST, 1898.

EDITORIAL.

We are pleased to be able to announce the beginning of a series of articles on "Laboratory Methods in Bacteriology," by Prof. F. G. Novy, of the University of Michigan, Ann Arbor, Michigan, in the September number of the Journal. This series will, like the "Notes on Microscopical Technique," deal in a concise and perfectly plain manner with the methods used in the laboratory, the first paper being "Examination of Bacteria." The rapid, accurate, and practical methods which have made courses in Dr. Novy's laboratory so popular are a sufficient guarantee of the value which these papers will be to the readers of the Journal.

* * *

The July installment of Dr. G. Carl Huber's "Notes on Microscopical Technique" was marked erroneously "continued," as the fifth paper concluded the series. These papers will shortly be published in book form and will be Volume I of the Library of Applied Microscopy.

* * *

Beginning with the September number of the Journal, the department of "News and Notes" will be made a special feature. It is desired to make this department represent the everyday life of the users of the microscope in all kinds of laboratories, the place where suggestions and queries may be exchanged in an informal manner and where many a useful process, bit of apparatus, method of demonstration, specially suited subject for demonstration, etc., may be preserved from the oblivion of forgetfulness. Many of our readers are young

teachers to whom the experience of others is of the greatest benefit. We request "News and Notes" from all users of the microscope, believing they will be of mutual interest and benefit.

NEWS AND NOTES.

Minor notes on technique, personals, news items, notices of meetings of societies, conventions, etc., will be received up to the twenty-second of the month preceding issue.

Marine Biological Laboratory, Wood's
Holl, Mass.

The season just closed has been a very profitable one, much valuable work having been accomplished. The following list shows the attendance in the various laboratories.

INVESTIGATORS.

- Bridgham, J., Brown University.
Byrnes, E. F., Girls' High School, Brooklyn.
Case, E. C., Wisconsin State Normal.
Clapp, C. M., Mt. Holyoke College.
Conklin, E. G., University of Pennsylvania.
Compton, H. E., Jr., Columbia University.
Curtis, W. C., Johns Hopkins University.
Dahlgren, Ulric, Princeton University.
Fling, H. R., State Normal, Oshkosh.
Graf, A., Pathological Institute, N. Y.
Hargitt, C. W., Syracuse University.
Hayashi, K., University of Chicago.
Haynes, J. A., Emma Willard School.
Hazen, A. P., Bryn Mawr College.
Hunter, G. W. Jr., University of Chicago.
Hunt, A. E., Manual Training High School, Brooklyn.
Jones, W. C., Northwestern University.
Keith, S. E.
Lander, C. H., Central High School, Cleveland.
Lafevre, G., Boys' High School, Atlanta.
Lillie, F. R., University of Michigan.
Lillie, R. S., University of Chicago.
Loeb, J., University of Chicago.
Lynn, E. P., Bradley Poly. Institute.
Mead, A. D., Brown University.
Mason, H. H., Brown University.
Montgomery, T. H. Jr., University of Pennsylvania.
Moore, A., Vassar College.
Morrill, A. D., Hamilton College.
Murbach, L., Central High School, Detroit.
Neal, H. V., Knox College.
Nickerson, M. L., University of Minnesota.
Norman, W. W., University of Texas.
Packard, W. H., University of Chicago.
Patten, W., Dartmouth College.

Risser, J., Iowa College.
 Rynearson, Edward, High School,
 Pittsburg, Pa.
 Sampson, L. V., Bryn Mawr College.
 Shearer, C., McGill University.
 Smallwood, W. M., Alleghany College.
 Strong, O. S., Columbia University.
 Treadwell, A. L., Miami University.
 Turner, A. H., Mt. Holyoke College.
 Waite, L., Harvard University.
 Watase, S., University of Chicago.
 Wing, A. G., Woman's College, Brown
 University.
 Wilson, E. B., Columbia University.

INVERTEBRATE ZOOLOGY.

Allen, L. W., University of Chicago.
 Ballou, A. M., Brown University.
 Bishop, W. H., Delaware College.
 Chandler, A. P., Wellesley College.
 Cleverdon, E., University of Michigan.
 Eckel, L. S., Fenn Grammer School.
 Enteman, M. M., University of Wis-
 consin.
 Garrey, G. H., University of Chicago.
 Mesenthal, H. C., Columbia University.
 Mix, G. D., Drury College.
 Parke, H. H., University of Michigan.
 Perkins, M. A., Smith College.
 Pierce, R. M.
 Rea, P. M., Williams College.
 Read, E. A., Mt. Holyoke College.
 Rucker, A., University of Texas.
 Rushmore, J. C., Williams College.
 Savage, A. D., Hancock School.
 Stickney, W., Dartmouth College.
 Stone, E. L., Woman's College, Balti-
 more.
 Sylvester, P. H., Harvard University.
 Taft, E. F. W., Canston, R. I.
 Wood, M. A., Woman's College, Balti-
 more.
 Zinser, H. W., Columbia University.

EMBRYOLOGY.

Atwater, D. H., Syracuse University.
 Barrows, A. I., Smith College.
 Block, E. B., University of Minnesota.
 Budington, R. A., Williams College.
 Busch, F. C., University of Buffalo.
 Chester, W. M., Colgate University.
 Conley, W. T., High School, Columbia,
 Mo.
 Crampton, C. W., College of Physicians
 and Surgeons.
 Francis, W. W., Johns Hopkins Uni-
 versity.
 Fried, G. A., Harvard University.
 Goldfrank, F., Harvard University.
 Hart, M. E., Western College.
 Hindley, E., Brown University.
 Humeston, E. J., Hamilton College.
 Kerr, A. T. Jr., University of Buffalo.
 Kirkbridge, M. B., University of Penn-
 sylvania.
 Kroeber, J., Bryn Mawr College.
 Landacre, F. L., Ohio State University.
 McCulloch, R., Vassar College.
 Newman, H. H., University of Chicago.

Richardson, H. H., Smith. Institute.
 Sachs, E., Harvard University.
 Scott, G. G., Williams College.
 Simonds, M. E., Woman's Medical Col-
 lege, N. Y.
 Stein, Leo D., Johns Hopkins Univer-
 sity.

BOTANY.

Conover, L. L., Detroit High School.
 Crocker, A. C., Williams College.
 Davis, Bradley M., University of Chi-
 cago.
 Haroer, R. A., University of Wisconsin.
 Loder, E., University of Pennsylvania.
 Lyon, F. M., University of Chicago.
 McRae, L. J., Franklin Gram. School,
 Boston.
 Minor, M. L., Girls' High School, N. Y.
 Moore, G. T., Harvard University.
 Morse, C. L., Wellesley College.
 Newman, H. C., Woman's College, Bal-
 timore.
 Paterson, R. C., McGill University.
 Round, E. M., High School, Providence,
 R. I.
 Semour, B., Vassar College.
 Shaw, W. R.
 Smith, W. R., University of Chicago.
 Smith, F. G., Smith College.

Owing to the extreme variation which existed in the sizes of threads and in the diameters of the screw of microscope objectives, making it impossible to use objectives of various makes interchangeably on the same instrument, the Royal Microscopical Society adopted a standard screw according to the following specifications:

Thread—Whitworth screw, i. e., a V shaped thread, sides of thread inclined at an angle of 55° to each other, one-sixth of the V depth being rounded off at the top and the bottom of the threads.

Pitch, 36 to the inch.

Diameter of thread on object glass, 0.7982 inch.

Diameter of screw of nosepiece, 0.7674 inch.

All manufacturers of microscopes were asked to adopt these standard sizes and to use them on their instruments. In order to insure uniformity, should manufacturers adopt their suggestion, they offered to supply standardized taps and dies to all makers requesting them. The most prominent manufacturers in Europe and America adopted the suggestion of the society a number of years ago and were supplied with the taps and dies.

The society was very unfortunate in sending out taps and dies which were not perfectly standardized, and, although the various makers tried to meet the requirements and probably did make

their work according to the patterns supplied by the society, users of instruments continued to find the same difficulty as before, viz., objectives of one maker would not fit the microscopes of another.

The society has therefore recently gone over the subject again, and has had made a number of standard taps and dies which are reliable, and which are now offered to makers of microscopes desiring to comply with the standards of the society.

Great care should be exercised in transferring very delicate tissues from a lighter to a denser fluid, to prevent shrinking. This is especially true when transferring from absolute alcohol to such clearing fluids as chloroform, turpentine, cedar oil, etc. This can be accomplished easily by carefully introducing the clearing fluid into the dish containing the alcohol, so that it shall remain in a stratum below the alcohol. The specimen will gradually sink into the clearing fluid as the alcohol is displaced. The same process may be followed with advantage in embedding delicate tissues if they are cleared in chloroform or some other solvent for paraffin. Bits of paraffin are gradually dropped into the chloroform, and, as they dissolve, become infiltrated into the tissue more and more as the solution becomes denser. Slight warming will allow the tissue to take up a greater amount of paraffin. From such a bath the tissue can be embedded after remaining a very short time in the melted paraffin.

Prof. G. H. French, writing of his method of preparing the glandular stomach of birds (*Jour. of App. Micro.*, Vol. I, No. 6) says, "In staining, borax carmine was used where it was desired to bring out the general structure. For differentiation, the various double stains, eosin-methylin blue, eosin-methyl green, haematoxylin-gold orange, haematoxylin-borax carmine, and picro carmin were employed. The last two gave the best results. The Erlich-Biondi-Heidenhain stain gave fine results with nearly all the tissues, but in none so marked differentiation as in those of the gizzard.

Pure carbolic acid has proven an excellent clearing agent for polyzoa, parts of insects, vegetable tissues, etc. It does not render them brittle like some of the other agents. It should not be used where the details of very delicate tissues are sought, as the tissue is apt to shrink after being put in the balsam.

A macerating and staining medium, especially for vertebrate nerve tissues, is made in the following way: to 100 cc.

of water add 5 grams ammonium chromate, 5 grams potassium phosphate, and 5 grams of sodium sulphate. The fresh tissue is left in the fluid from one to five days, when it is transferred to a mixture of this fluid and ammonia carmine, equal parts, for twenty-four hours.

Publications Received for the Journal Library.

- Studies from the Zoological Laboratory, The University of Nebraska. Henry B. Ward, Director. No. 22.—A Treatise on the Parasitic Worms of Domesticated Birds.
- Studies from the Zoological Laboratory, The University of Nebraska. Vol. I, No.'s 1-20.
- Development of Methods in Microscopical Technique. Henry B. Ward, University of Nebraska. Reprint from the transactions of the American Microscopical Society, 1897.
- Zoology in the High School Curriculum. Henry B. Ward, University of Nebraska. Reprint from the proceedings of the National Educational Association, 1897.
- Note on *Taenia confusa*. Henry B. Ward. Reprint from the *Zoologischen Anzeiger*, No. 540.
- Minutes of the New Jersey State Microscopical Society, April, '71 to June, '94. Oct. '94 to April, '97.
- An Apparatus for the Bacteriological Sampling of Well Waters. H. L. Bolley, Fargo, N. Dakota. Reprint from the *Centralblatt for Bacteriologie u. s. w.* Band 22.
- A Method of Teaching Histology. Charles Minor Blackford, Jr., University of Georgia. Reprint from the *Charlotte Medical Journal*.
- Twenty-second and twenty-third Annual Reports of the American Postal Microscopical Club, June, 1898.
- Laboratory Guide for the Dissection of *Loligo pealii*, for use in the Biological Laboratory of Chamberlain University. W. F. Mercer.
- Bulletin No. 5, 1896.—U. S. Dept. of Agriculture, Div. of Veg. Pathology. The Pollination of Pear Flowers. Merton B. Waite.
- Bulletin No. 9, 1896.—U. S. Dept. of Agriculture, Div. of Veg. Pathology. Bordeaux Mixture, Its Chemistry, Physical Properties, and Toxic effects on Fungi and Algae. Walter T. Swingle.
- Bulletin No. 10, 1896.—U. S. Dept. of Agriculture, Div. of Veg. Pathol. Copper Sulphate and Germination. Treatment of Seed with Copper Sul-

- phate to Prevent Attacks of Fungi. Walter H. Evans.
- Bulletin No. 15, 1896.—U. S. Department of Agriculture, Division of Vegetable Pathology. Some Edible and Poisonous Fungi. Dr. W. G. Farlow.
- Reprints from the Year Book of the United States Department of Agriculture as follows:
- Frosts and Freezes as Affecting Cultivated Plants. B. T. Galloway, '96.
- The Two Freezes of 1894 and 1895 in Florida, and What They Teach. Herbert J. Webber, '96.
- The Pineapple Industry in the United States. Herbert J. Webber, '96.
- The Division of Vegetable Physiology and Pathology. B. T. Galloway, '97.
- Influence of Environment in the Origination of Plant Varieties. Herbert J. Webber, '96.
- Diseases of Shade and Ornamental Trees. B. T. Galloway and Albert F. Woods, '96.
- Olive Culture in the United States. Newton B. Pierce, '96.
- Methods of Propagating Orange and Other Citrus Fruits. Herbert J. Webber, '96.
- Improvements in Wheat Culture. Mark Alfred Carleton, '96.
- Farmers' Bulletin No. 38.—U. S. Department of Agriculture. Spraying for Fruit Diseases. B. T. Galloway, Chief of Division of Veg. Physiol. and Pathology.
- Farmers' Bulletin No. 53.—U. S. Department of Agriculture. How to Grow Mushrooms. Walter Falconer, Division of Vegetable Physiology and Pathology.
- Farmers' Bulletin No. 68.—U. S. Dept. of Agriculture. The Black Rot of the Cabbage. Erwin F. Smith. Division of Veg. Physiol. and Pathology.
- Farmers' Bulletin No. 75.—U. S. Dept. of Agriculture. The Grain Smuts. How They are Caused and How to Prevent Them. Walter T. Swingle.
- Bulletin No. 11.—U. S. Department of Agriculture, Division of Vegetable Physiology and Pathology. Legal Enactments for the Restriction of Plant Diseases. A compilation of the Laws of the United States and Canada. Erwin F. Smith.
- Farmers' Bulletin No. 15.—U. S. Department of Agriculture. Some Destructive Potato Diseases, What They Are and How to Prevent Them. B. T. Galloway, Chief of Division of Vegetable Pathology.
- Farmers' Bulletin No. 17.—U. S. Department of Agriculture. Peach Yellows and Peach Rosette. Erwin F. Smith, Division of Vegetable Pathology.
- Farmers' Bulletin No. 30.—U. S. Department of Agriculture. Grape Disease on the Pacific Coast. Newton B. Pierce, Division of Vegetable Physiology and Pathology.
- Farmers' Bulletin No. 33.—U. S. Department of Agriculture. Peach Growing for Market. Erwin F. Smith, Division of Vegetable Physiology and Pathology.
- Bulletins No. 136, 137, 138, 139, 140, 141 and 142, New York Agricultural Experiment Station, Geneva, New York.
- Bulletin No. 136, on The Inspection of Nurseries and Treatment of Infested Nursery Stock, by V. H. Lowe, contains some half-tone and wood-cut plates illustrating the oyster shell bark louse, San Jose scale, and the woolly louse of the apple.
- Bulletin No. 139, V. H. Lowe, description of Plant Lice, their Enemies and Treatment, is illustrated by numerous half-tone plates.
- In Bulletin No. 142, the report of the director, W. H. Jordan, we find the following paragraph, which indicates the demand for scientific information as compared with popular interest in such matters a short time ago:
- "The mailing list of this station includes several divisions: (1) The officers of the United States Department of Agriculture and of all other experiment stations; (2) newspapers of this state and a few outside; (3) those persons who desire to receive our complete bulletin; (4) the main list or those who receive the popular bulletins. This latter list now numbers about 30,000 names. In two years our mailing list has increased about 10,000 names."

ABSTRACTS.

A Modification of Cullen's Method of Preparing Fresh Sections for Microscopic Work.

EUGENE HODENPYL, M. D.

"It is frequently desirable at surgical operations, at autopsies, or in general laboratory work, to obtain quickly stained sections for diagnostic purposes. Fresh unstained sections, while they are valuable for the study of certain lesions, are open to so many serious objections that they cannot be made use of for the purposes indicated. Moreover, fresh sections cannot be satisfactorily stained unless they have been previously fixed or hardened by some preservative. Of the various hardening agents which have been tried for rapid fixation of frozen

*Read before the New York Pathological Society.

sections, none had been found successful until Cullen ('Beschleunigtes Verfahren zur Färbung frischer Gewebe mittelst Formalins,' *Centralblatt für allgemeine Pathologie*, 1895, Bd. No. 11, pp. 448-450; also *Johns Hopkins Hospital Bulletin*, April, 1895, and May, 1897) suggested the use of formalin either before or after cutting, as a partial fixative, when fairly successful results were obtained.

"A serious objection to the use of this method I have found to be the shrinkage and consequent distortion which always occur to a greater or less extent. At times so great a shrinkage took place in my sections that they were entirely useless. At Dr. Prudden's suggestion, I have devised a scheme of fixing sections on cover glasses by means of albumen. This may be accomplished by impregnating sections with a solution of egg albumen, floating them on cover glasses, and finally coagulating the albumen. By this means shrinkage and distortion, which would otherwise occur from the subsequent action of alcohol, may be largely if not entirely prevented.

"This modification does not materially increase the time required to prepare stained fresh sections for the microscope. I have repeatedly cut sections of fresh tissues, fixed them on cover glasses, and have hardened, stained, and mounted them in as short a time as nine minutes. Furthermore, it permits the use of hardening agents other than formalin. Fair results have been obtained with osmic acid, mercuric chloride, etc. For purposes already indicated this modified method seems to be a valuable one, since it enables one to determine the nature of new growths, or the lesions of viscera, etc., within a few minutes—a procedure which would otherwise require hours or days to accomplish by the ordinary hardening and impregnating methods. Cullen's method, as may be imagined, is not applicable for all tissues. The results obtained by the suggested modification have been entirely satisfactory for diagnostic work, but for fine structural details other methods are still to be preferred.

"The technique of the method is as follows:

"1. Almost any form of freezing-microtome may be used. The freezing agent may be ether, carbonic acid, or rhigolene.

"2. Sections may be cut from perfectly fresh material, but more satisfactory and better results are obtained from material which has previously hardened one or two hours longer in ten-per-cent. formalin. (It is convenient to drop bits of tissue into ten-per-cent. formalin at the time of the operation or during the post-mortem examination. By the time they

reach the laboratory they are usually sufficiently impregnated to be cut and stained.)

"3. Tissues already hardened in formalin should be soaked in water a minute or two to remove the formalin before cutting.

"4. Sections as they are cut may be dropped directly into the albumen solution, where they remain until needed. A solution of albumen which has been found to answer the purpose is prepared by adding to 50 c.c. of egg albumen 150 c.c. of distilled water and sufficient of a solution (usually about 50 c.c.) of salicylic acid (saturated), which has been rendered slightly alkaline with lithium carbonate, completely to dissolve the albumen. The solution may be kept unchanged several weeks by adding a little gum camphor.

"5. Unhardened sections should be placed in five-per-cent. formalin three or five minutes, after which they are soaked in the albumen solution two or three minutes.

"6. Float sections on cover glasses. Remove excess of fluid with filter paper when necessary. Blot sections evenly, taking care not to use pressure enough to cause them to bear the imprint of the cloth. (The best blotting-material seems to be washed cheesecloth used in several layers. The use of filter paper, towels, muslin handkerchiefs, etc., for this purpose has not been satisfactory.)

"7. Transfer immediately to alcohol, alcohol and ether (equal parts), osmic acid, or mercuric chloride, etc., in order to coagulate the albumen and to fix the section and complete the hardening.

"8. Sections may be stained on the cover slip in various ways. For ordinary diagnostic work staining with haematoxylin and eosin and mounting in balsam answer well.

"9. Stain from two to five minutes in haematoxylin (Delafield's or Gage's).

"10. Decolorize by passing rapidly through acid alcohol—hydric chloride, 1 part; eighty-per-cent. alcohol, 99 parts.

"11. Wash thoroughly in water.

"12. Dehydrate and stain in eosin alcohol. (Eosin which has been precipitated from a saturated aqueous solution by acid stains connective tissue more sharply and gives better results than ordinary eosin. It is prepared by Fischer by adding to a saturated aqueous solution of eosin hydric chloride in excess. Filter and wash the precipitate with water until the acid is removed. Dry the precipitate and dissolve in alcohol.)

"13. Clear in oil of origanum, oil of cloves, creosote, zylol, etc.

"14. Mount in balsam after having cleaned the upper surface of the cover slip."

Journal of Applied Microscopy.

VOLUME I.

SEPTEMBER, 1898.

NUMBER 9

William A. Rogers, A. M., Ph. D., LL. D.

Professor Rogers was a man of such strong character and able mind that he naturally became a member of all the great societies which came within the limits of his activity. His main work was in Astronomy and Physics, fields in which accurate measurement is as important as in Microscopy.

To insure accurate measurement he investigated the various standard measures of length available, and came to appreciate the high value of the microscope in this investigation. Therefore, while he was an astronomer and physicist and used the microscope only as an instrument of precision, his sympathies turned to the group of men then known as the American Society of Microscopists, noting that among their efforts the realization of accurate micrometers was earnestly sought.

In 1882 he joined this society and at nearly every meeting since that time he presented one or more papers bearing upon micrometers or micrometry, and the question of expansion and contraction which so vitally concern their accuracy.

While his interest in accurate measurement might have been the primary reason for joining the society, his broad and generous mind entered into sympathy with the society's work as a whole. At the time of joining in 1882 he was fifty years old and had a national if not an international reputation, hence he was in a position to render great assistance in the general management of the society. His general good sense acted as a brake on some of the radical members, but as I look back over his career among us, what appeals to me most strongly was his interest in the younger members. His words of encouragement and praise for any creditable work were so genuine that one could not help feeling that one would do his best to make the next work more worthy of the generous recognition.

Prof. Rogers, in spite of his other duties and engagements, never hesitated to bear more than his share of the burden of the society. In turn the society gave to him all the honors it had to offer; and although it had not the reputation of many of the societies of which he was a member, yet in the performance of his duties toward this society no one could be more conscientious and painstaking. I presume the preparation of no address by a president of the Microscopical Society ever cost more labor and solicitude than the one given by him at the tenth annual meeting in Pittsburg, in 1887.

It has just been said that Prof. Rogers came in to be one of us, to give his unstinted labor and impart some of his wholesome enthusiasm and faith in the value of our work. He did all this and more. In times of depression, he gave not only general encouragement, but showed in detail how to advance the interests and increase the success of the society.

That the honor was to us rather than to him, is shown from the fact that the year before joining the American society, he had been made an honorary fellow of the Royal Microscopical Society of London.

He was a fellow of the American Association for the Advancement of Science and was three times honored by a chairmanship of its sections. In 1873 he was elected to membership in the American Academy of Arts and Sciences.

Yale College conferred upon him the honorary degree of A. M. in 1880 in recognition of his work in Astronomy. In 1886 Alfred University, at its semi-centennial, gave him Ph. D., and finally in 1892, thirty-five years after graduation, his alma mater, Brown University, conferred upon him the degree of LL. D.

Prof. Rogers was a teacher and an investigator. His warm heart and noble

enthusiasm made it easy for pupils to follow him. His investigations were guided by so clear a mind and prosecuted with such tireless industry that success rarely failed to crown his efforts.

In 1857 he became an instructor in Alfred Academy, and in 1859 professor in Alfred University. From 1870 to 1886 he was connected with Harvard University, most of the time as assistant professor of Astronomy, in the observatory. In 1886 he became Professor of Physics and Astronomy in Colby University; and at this time, when the nation is so proud of its navy, it should not be forgotten that Prof. Rogers served in it from 1864 to the close of the war.

In 1897 Prof. Rogers resigned his chair at Colby and was made the head of the Babcock School of Physics, which had just been established in Alfred University; and its plans were laid with all the wisdom and experience which his long and fruitful life had given him. His ripest experience was thus to work in the same field that had felt the uplift of his youthful enthusiasm nearly forty years before. But like many another circle of human hope and aspiration, this was not to be completed. On March 1, 1898, death came.

SIMON H. GAGE.

Note.—For other details concerning the life and work of Professor Rogers the reader is referred to the Quarterly Bulletin of Alfred University, July, 1897, and to the Physical Review, Vol. VI., pp. 315-319. Both contain a portrait and a list of his scientific papers.

A Convenient Method for Mounting Filamentous Algae and Fungi.

1. Treat fresh material with chromo-acetic acid for sixteen to twenty-four hours. Formula:

Chromic acid 4-10g.
Glacial acetic acid 6-10g.
Water 99cc.

Instead of this, Flemming's weaker solution may be used. Allow the Flemming's to act for about two hours, then transfer to chromic-acetic acid which should act for ten to twenty-four hours. This often avoids the blackening caused by the osmic acid.

Formalin two to six per cent., is a fair killing and fixing agent for many algae. Twenty-four hours is sufficient, but material may be left here indefinitely.

2. After any of these killing and fixing agents, wash in water ten to twenty-four hours, either using running water or changing frequently.

3. Stain in Haidenhain's iron alum haematoxylin. For algae we use the stain as follows:

a. Two per cent, aqueous solution of iron alum, two hours.

b. Wash in water two to six hours.

c. Stain in one-half per cent. aqueous solution of haematoxylin six hours, or "over night."

d. Wash in water. Some recommend a few minutes, others several hours.

e. Treat again with iron alum until the stain suits you. It may take a few minutes and may take an hour or more. The only safe way is to examine frequently with a microscope.

f. Wash in water for an hour or two. If lack of time proves an objection to this elegant stain, use aqueous eosin thirty minutes, transfer directly from the stain to a one per cent. solution of acetic acid which should act for two to five minutes, then wash thoroughly in water for an hour or more to remove the acid.

Mayer's haemalum is good where the nuclei are the only details cared for. Chromatophores and cell walls stain lightly or more frequently not at all. Stain two to twelve hours and wash in water for about half an hour.

4. Transfer to dilute glycerine; ten per cent. is about right. Allow the stained material to stand in this in a watch glass or saucer, freely exposed to the air, but to as little dust as possible. The water will evaporate and the material will be in glycerine thick enough for mounting purposes in two to four days. Mount in this glycerine or in glycerine jelly. Seal in the usual manner.

The Flemming's fluid followed by iron alum haematoxylin gives such elegant results that even a rather busy man can well afford the time. Pyrenoids of algae take a brilliant black with this combination, the nuclei show fine details, especially if undergoing division, the cytoplasm though of a plain dull gray color, is exquisitely differentiated.

CHARLES J. CHAMBERLAIN.

Botanical Department, University of Chicago.

Laboratory Notes.

The writer has for a number of years made use of the following simple method for mounting sections from a number of tissues under the same cover glass, and has found it so useful in class-room work, especially in instructing large classes, that he feels prompted to suggest its use to others situated as he is. The methods consist briefly in embedding, side by side, in one paraffin block, a given number of tissues cut in the form of rectangular blocks of about one-eighth of an inch in thickness. These, if carefully embedded, may readily be

cut in one section. They are then fixed to a cover-glass of suitable size by means of the water-albumen method suggested by the writer. After the removal of the paraffin the sections may be stained at pleasure.

The applicability of this method may be shown by a number of examples. Portions showing typical regions of the several parts of the alimentary canal, all hardened after the same method, are divided in small pieces suitable for embedding, the following pieces being selected: oesophagus, junction of oesophagus and cardiac end of stomach, cardiac and pyloric region of stomach, junction of pyloric end of stomach with small intestine showing Brunner's glands, small intestine, small intestine with solitary lymph follicle, and large intestine. These pieces are embedded in two paraffin blocks in the order named, cut and fixed to two cover-glasses, one inch by three-quarter inch, stained in haematoxylin and eosine or haematoxylin and Van Gieson's acid fuchsin-picric acid mixture, and mounted on one slide. In such a preparation the student can readily pass from one section to another, make comparisons, and will, I believe, form a clearer idea of the difference in the structure of the several regions of the alimentary canal, than he would by studying eight or ten different slides. Much time is saved the instructor in preparing material, and the student in mounting sections. Again, pieces taken from the various glands—serous and mucous salivary glands, pancreas, liver, kidney, thyroid, etc., may be mounted in one block and treated in the same way. The various adenoid tissues—simple follicle, lymph gland, thymus, and spleen may be similarly treated, or, to give another example, voluntary, heart, and involuntary muscle tissue, may in like manner be stained and mounted under one cover-glass. I have found that such preparations emphasize and fix the characteristic features of the above named tissues better than a series of separate sections do.

The applicability of this method has not been tested in teaching classes in pathological histology. I may venture to suggest, however, that there also the method may be of use. For instance, pieces taken from tissues showing the several types of carcinoma or sarcoma may be treated after the above method. Pieces taken from a collection showing the various pathological conditions of the kidney or liver or any other organ may be blocked in as compact a form as possible and similarly treated.

The suggestions here offered may have a much wider use in laboratories than the writer is aware of. He has not ob-

served them in laboratories with which he is more or less familiar.

G. CARL HUBER.

Histological Laboratory, University of Michigan. October 19, 1898.

Laboratory Methods in Bacteriology.

DR. F. G. NOVY.

Examination of Bacteria.

This and the following papers are written at the request of the editor, and are primarily intended for the busy practitioner who has not the time to take the regular course in a well equipped laboratory. Although he cannot spend one or two months away from his patients, yet one or two hours a day may be found which, if properly used, will enable him in a short time to acquire the necessary knowledge and skill in identifying the most important disease producing bacteria. Once acquired, this knowledge will be found to be an invaluable aid in the diagnosis of certain infectious diseases.

Many, undoubtedly, are deterred from entering upon such self-study because they believe that such work can be done only in a well equipped laboratory, and that too great an expense would be incurred in providing one's own outfit. It is the purpose of the writer to show that a great deal of good work can be accomplished along this line at little expense. The satisfaction of broadening one's horizon of thought will amply repay the time and expense involved.

The first and most expensive piece of apparatus necessary for work is a good microscope. Every physician, without exception, should have and be able to use to advantage this instrument. The rapid strides in scientific medicine have made this a necessity. Fortunately, with the increased demand for this means of investigation, the price has been lowered so that a good microscope is within the reach of every one. The beginner who finds it necessary to economize will do well to purchase an instrument with two eyepieces and two objectives, the latter being designated as two-thirds and one-eighth-inch. Such an instrument can be purchased for about \$50.00. Later on, a triple revolving nosepiece and a one-twelfth-inch homogeneous oil-immersion objective can be added.

The necessary accessories are:

- A pair of forceps,
- A platinum wire,
- Three concave glass slides,
- Fifty glass slides,
- One-half ounce No. 1 cover-glasses, three-fourths inch in diameter.
- One tube of Canada balsam.

The forceps may be of any form, but a fine-pointed instrument is well adapted for the handling of the thin cover-glasses. Inasmuch as there are certain drawbacks to the use of the ordinary forceps, I have for several years employed a modification better adapted for the object in view. This cover-glass forceps of mine is reproduced in Fig. 1.

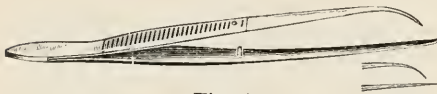

Fig. 1.

The lower blade of the forceps is flat and has a wide end and sharp edge. It can therefore pick up cover-glasses readily from the table or from any flat surface. The upper blade of the forceps ends in a fine point and is bent downward so that an appreciable space remains between the two blades when the points are brought together. In the ordinary forceps, during staining, the liquid tends to creep up along the capillary space between the blades, and as a result the hands of the student display more color than does his preparation. This capillarity is done away with in this instrument, especially if the cover-glass is held at the very edge. The pressure exerted must be light. The advantages mentioned are such as will commend the forceps to those who have occasion to frequently handle cover-glasses. The above instrument can also be obtained provided with a clamp as in the case of Ehrlich's forceps.

The platinum wire should be of number 21 gauge and about two inches long. It is fused into the end of a glass rod or tube six or seven inches in length.

ISOLATION OF BACTERIA.

A great variety of bacteria, moulds, and yeasts can be obtained by the beginner from the air. It matters not where he may live, the air will always supply a large number of species. The following simple procedure will enable anyone to grow these bacteria from the air, and thus obtain a variety of organisms suitable for examination in the living condition and for staining purposes.

Place two or three sound potatoes and a knife in a vessel of water and boil for twenty minutes. Then pour out the water, and as soon as the potatoes are fairly cool, cut them in two with the knife, which has been sterilized by boiling. Utmost care must be taken not to touch the blade of the knife or the surface of the cut cooked potato. Each half is placed on a piece of paper with the cut

surface uppermost. The halved potatoes can be exposed uncovered for a variable length of time to the air, say five, ten, fifteen, or thirty minutes. They should be carefully covered with a clean glass tumbler, without touching the potato. After thirty-six to forty-eight hours, the potato will usually show one or more pinhead growths. These increase rapidly in size in another day or two. If a well cooked potato is placed under cover immediately after halving it, and after a day or two shows no growth on the surface, it will indicate clearly that the operator is doing the work as it should be done, that is, under strictly sterile conditions. The growths, therefore, that develop upon the other potatoes which have been exposed to air are due to organisms which, floating about in the air, have dropped down onto the potato and have found this to be a good soil to grow upon.

When first seen, the growth will be pin-point or pinhead in size. Inasmuch as it results from a single germ which has dropped down onto the potato, it follows that this growth contains only that particular organism. The single organism rapidly multiplies and gives rise to its own kind. This pinhead growth, known as a colony, since it is made up of only one kind, is a pure culture of that organism.

EXAMINATION OF LIVING BACTERIA.

When the colonies have developed on the potatoes, they should be examined and studied carefully in the living condition. To do this, a little of the growth is picked up on the end of the platinum wire, which first, however, has been heated in a flame and allowed to cool. That is to say, the platinum wire must first be sterilized.

The wire, with a little of the growth, is then touched several times to a drop of water on a glass slide. The drop of water should as a result show a visible cloudiness. It is then covered with a cover-glass and examined under the microscope.

The two-thirds-inch objective will show up some fine granules in the water, but their form and nature cannot be made out. To ascertain this, examine with the one-eighth-inch objective, and later with the one-twelfth-inch oil-immersion objective if such is at hand.

The true nature of the growth will now be apparent. As a rule, the organism under examination will have the form of a rod. It may be actively motile, moving rapidly from place to place, or it may show only a gentle swaying motion and remain in one place (Brownian motion). The rod-shaped organism is designated as a bacillus. The greatest variety of

bacilli may be expected in the various colonies that develop on the potatoes. Some will be long, others short; some will be narrow, others very thick; some will grow in long threads, others in pairs; some will have motion, others not. At other times, the organism under examination will be perfectly round or spherical, and in that case it is known as a micrococcus. Again, the large oval yeast cells may be met with.

The examination of the living organism on an ordinary glass slide, in the manner indicated, is not always satisfactory, because the liquid soon begins to evaporate and as a result rapid currents are established in the liquid. To overcome this evaporation it is customary to examine the material in a hanging drop. For this purpose a thick glass slide having a concave well in the middle is made use of.



Fig. 2.

The "hanging drop" is easily made in the following manner: Place a small drop of water on a clean cover-glass on the table. The drop must be small enough so that it will not run if the cover-glass is placed on edge. The growth from the potato is then touched off into the drop of water by means of a sterile platinum wire. A ring of vaseline is then placed around the edge of the well on the upper side of the concave slide, by means of a brush or match stick. The slide, with its ring of vaseline, is then inverted over the cover-glass and gently pressed down. The cover-glass now adheres to the slide, which is then inverted. Care should be taken to see that the vaseline is continuous around the edge of the well. If such is the case, no evaporation of the drop of water can take place and hence the hanging drop can be examined at leisure and without the presence of annoying currents in the liquid. Fig. 2 indicates the hanging drop in longitudinal cross-section.

STAINING OF BACTERIA.

One of the most important conditions in order to obtain good results in staining bacteria is to have perfectly clean cover-glasses. The latter should be so clean that, when a drop of water is placed on any of them and spread over the surface by means of a platinum wire, it will remain spread out as a thin film. If it gathers in minute droplets, which follow the wire and refuse to spread out, the cover-glass is not clean and is not suitable in that condition for staining purposes. The thin layer of fatty matter

must be removed, and this is often impossible to do if the ordinary procedure is followed. The author's method of obtaining absolutely clean cover-glasses is as follows:

The cover-glasses are immersed in strong or absolute alcohol and then wiped clean and dry with a clean piece of muslin. They are then placed in an Esmarch dish and heated in a dry-heat sterilizer at a temperature of 180° to 200° for one-half to one hour. The organic matter remaining on the cover-glasses is thus subjected to dry distillation and is completely removed. The cover-glasses thus treated will allow the drop of water to spread over the entire surface and when it dries it does so evenly.

Another procedure can be followed by the beginner, if necessary, and that is to pass the cover-glass six or eight times through a Bunsen flame. This takes, of course, more time and not infrequently the cover-glass will crack.

Anilin dyes are employed for staining bacteria and it will be well to procure two of these, fuchsin and gentian violet. The crystals are added to strong alcohol in a bottle till saturation results. The two strong alcoholic solutions thus prepared are never used as such, but are first diluted. Inasmuch as the diluted dye does not keep well, no more of this should be prepared than is necessary for several weeks work. Some of the strong alcoholic solution of the dye is placed in a one-ounce tincture bottle and then diluted with three or four parts of water. The bottle should be provided with a cork through which passes a glass tube, the lower end of which is slightly drawn out. This then serves as a pipette (see Fig. 3).

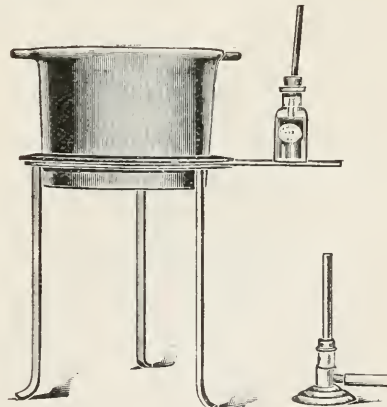

Fig. 3.

The cover-glasses and the dyes being in readiness, the beginner can now proceed to stain the various bacteria found

growing on the potatoes. For this purpose a cover-glass is placed on the table, or, better, on a short board, and a drop of water not much larger than a good sized pinhead is placed in the middle. By means of the sterile platinum wire, a portion of the growth is transferred to the droplet of water. The latter should now be distinctly cloudy. Again sterilize the wire by heating in a flame and when cold spread out the droplet of water over the surface of the cover-glass. The water evaporates rapidly, if the drop is small, and leaves a perfectly even residue distributed over the entire surface. Should the drop be large, it will dry slowly and leave unsightly "shore lines."

As soon as the water has evaporated the material is fixed to the cover-glass by means of heat. For this purpose the cover-glass is taken up in the forceps, specimen side up, and is touched once or twice to a Bunsen or alcohol flame. This little operation requires judgment and care. The cover-glass must become heated sufficiently to fix the specimen, so that it will not wash off when subsequently treated with the dye and with water. On the other hand, too much heating will destroy the organism and render it incapable of taking up the dye. The best rule to follow is to touch the cover-glass once or twice to the flame and then bring it at once in contact with the end of the finger. If the cover-glass is so hot that the finger must be withdrawn at once, it indicates that the specimen is fixed and that it is not necessary to heat any more. The cover-glass, with the specimen side still turned up, is held in the forceps and a drop or two of water is placed on the specimen. Then two or three drops of the dilute gentian violet or fuchsin are added and allowed to act for one-quarter to one-half minute. The cover-glass is then washed perfectly clean of dye by being held under a tap, or by rinsing in one or two glasses of water. It is then touched edgewise to a piece of filter or blotting paper in order to drain off the excess of water, and is then placed on the paper with the specimen side turned up. By gentle rotation of the cover-glass, the lower surface becomes perfectly dry. A clean glass slide is now brought down over the cover-glass, the upper or specimen surface of which is still moist. The cover-glass now adheres to the slide by means of the thin layer of liquid. The specimen is now turned over so that the cover-glass rests on the slide. It is now examined under the microscope with the one-eighth-inch or one-twelfth-inch objective. When making this examination a thin film of water should be between the slide and cover-glass, so

that the under side of the specimen should be moistened by the water. The bacteria should be stained a deep violet or a deep red, according to the dye employed. Failure to take the stain properly may be due to over-heating while fixing the specimen, or to a weak dye, or to a too short exposure to the dye. By repeated trials, the exact conditions necessary can be ascertained and then followed without any difficulty.

In the method as described above, the dye is not added direct to the cover-glass, but to a drop of water which is first placed upon it. This little deviation from the process, as ordinarily described, serves to prevent over-staining and also deposition of coloring matter.

The color can be forced into the specimen, thus making it stand out more sharply than would otherwise be the case, by holding the cover-glass with the dye on it over a low Bunsen or alcohol flame till vapors begin to rise. The specimen is then washed as before.

Instead of heating the dye on the cover-glass, it may be heated before use. For this purpose the bottle of dye is placed on an iron plate, and this is heated by a low flame. Fig. 3 shows such an iron plate as used in the author's laboratory, slipped under the flange of the ordinary water-bath.

When it is desirable to preserve a stained specimen, this should be floated from the glass slide by the addition of a drop or two of water to the edge of the cover-glass. The latter should then be placed, specimen side turned up, under a watch-glass or tumbler until perfectly dry. A drop of Canada balsam is then placed in the center of a clean slide and the dried cover-glass, if necessary, waved once or twice over the flame, is inverted and brought down on the balsam with the specimen side turned down. On gentle pressure, aided by gentle heating of the slide if need be, the balsam will spread out evenly under the cover-glass.

The entire process of simply staining can be briefly summarized as follows:

- Clean cover-glass.
- Spread specimen.
- Dry in air.
- Fix in flame.
- Add drop of water.
- Add dilute-dye one-quarter to one-half minute.
- Wash in water.
- Examine in water.
- Dry in air.
- Mount in balsam.

University of Michigan.

(To be continued.)

The American Microscopical Society.

The twenty-first annual meeting of the American Microscopical Society was held at Syracuse, N. Y., August 29th to September 12th, inclusive. The meeting was a very interesting and successful one, the number and practical nature of the papers presented, the satisfactory report of the treasurer, and the earnest enthusiasm of the members in attendance show the society to be in excellent condition.

The life of the American Microscopical Society began with the general use of the microscope, and it has devoted itself to the most important features of microscopical work, as they presented themselves during the entire period of its existence. Its members have contributed largely to the development of the microscope, both as to its optical excellence and mechanical convenience, and have applied it in the investigation of



DR. WM. C. KRAUSS.

Niagara University. President A. M. S., 1898-9.

every department in natural science. It numbers among its members representatives of almost every class to whom the microscope is of importance,—teachers of subjects involving the use of the microscope, investigators whose researches require it, medical practitioners whose daily practice includes its use, workers in the industries, and lovers of nature and natural phenomena, who turn to the microscope in their leisure hours for recreation. In any organization the aim of that organization may be said to be that of the majority of its members. The majority of the members of the American Microscopical Society are employed in practical work requiring the use of the microscope as a means of obtaining certain results, hence the aim of the society may be said

to be the development of the most practical methods of using the microscope, and this includes of course every detail of all processes involved, of the best



PROF. H. B. WARD.

University of Nebraska. Secretary A. M. S., 1898-9

methods of making and recording observations, of the most effective means of demonstrating these methods to others, and of the most convenient apparatus to be used for these purposes.

There are other societies for the consideration of the problems involving the determination of the various conditions discoverable only by means of the microscope, the systematic arrangement of organic and inorganic things, etc.; but the American Society is devoted to the consideration of how to obtain results necessary before deductions can be made.



DR. G. CARL HUBER.

University of Michigan. First Vice-president
A. M. S., 1898-9.

It has a distinct and practical field, and its meetings and proceedings will be found helpful to teachers and laboratory workers in every department of science,

investigators, and all interested in the practical use of the microscope. The local committee made every possible arrangement for the comfort and entertainment of the visitors. The meetings were held in the new building of the Medical department of the Syracuse University. This building and the equipment of the laboratories was in itself very interesting and instructive. We

ratus are kept in a wall case, on the side of the room not occupied by the work tables. The students are required to



DR. A. M. BLEILE.

Ohio State University. Second Vice-president
A. M. S., 1898-9.

therefore append a brief description of them, as representing a type of equipment and method of handling classes.

All the laboratory rooms in the building are so planned that there are windows on three sides. The working tables for the students are arranged around the three sides of the room having light, and are attached to the wall for the purpose of doing away with the vibrations of the floor. In the Histological laboratory, and



PROF. S. H. GAGE.

Cornell University. Member Executive Committee,
A. M. S., 1898-9.

in the Bacteriological and Pathological laboratories, the apparatus which is intended for the common use of the students is placed upon tables conveniently located in the central portion of the room, while the microscopes and other appa-



DR. V. A. MOORE.

Cornell University. Member Executive Committee
A. M. S., 1898-9.

furnish their own equipment of watch glasses, dissecting instruments, slides, covers, bottles, etc., and a small locker attached to the wall space between the windows, and high enough above the tables to be out of the way of the instruments is provided for containing them. Each work place is provided with an incandescent light so that work can be done at night. Frosted globes have been found the most satisfactory, as with



DR. A. C. MERCER.

Med. Dept. Syracuse University. Member Executive Committee, A. M. S., 1898-9.

the plain globes, the image of the incandescent filament is often troublesome. The floors and work benches are hard oiled wood, the ceilings are of steel. Perfect ventilation is maintained by means of artificial draft.

The professor's private laboratory and study is immediately connected with each laboratory, and in it the work of preparing sections and material for class demonstration is done.

The Physiological laboratory is perhaps the most completely equipped for actual student work of any in this country, there being twelve complete sets of

demonstration apparatus for actual students' work. All of the appointments of this laboratory are methodically correct, and while space prevents a detailed description of them, we cannot refrain from giving one particularly practical feature which might profitably be introduced into other lines of work, viz., each set of apparatus is mounted upon a table and is accompanied by a fixed diagram of that apparatus, which is constantly before the student. This diagram shows the location of every piece and by means of a color scheme the wiring for electrical apparatus. The names of all parts are

one color, while the wires furnishing the induction coils are given a different color, and so on. In addition to the twelve work tables of special apparatus, three sides of the room are provided with work tables attached to the walls, and supplied with apparatus stands, reagent cases, etc., with wall lockers for the students' private material. On these side tables the dissections are made, also general preparations, some of which are afterwards used for experimental purposes with the measuring and recording apparatus. Professor Gaylord P. Clark, who has charge of this laboratory, has



A Corner in the Library, Medical Department, Syracuse University.

plainly indicated on the diagram, and it is therefore possible for the lecturer to direct a series of experiments, even with beginning students, with the assurance that his explanations of the apparatus to be used and directions for performing the experiments will be understood. As the most of the apparatus in the physiological laboratory is actuated by electricity, requiring several systems of wires, the same color scheme which is used in the diagram is applied to the wires; for example, each of the twelve recording drums is provided with a marker, and the twelve markers are actuated by a single pendulum, which can be adjusted to mark two seconds, one second, etc. The wires from this pendulum are given

devised a number of very ingenious pieces of apparatus for his work, among these a representation of the mammalian circulatory system, showing the general distribution of arteries, veins, capillaries, etc., and having a mechanical device for demonstrating the effect of the contraction of the heart, and of respiration, etc., upon the blood pressure, these various changes being recorded by a sphygmograph, just as though the experiment were being performed upon a living animal. Another apparatus is designed to demonstrate the course of the principal nerve tracts in the cord and in the brain, the tracts being indicated by colored threads, which are held in place at intervals by wooden sections, which are

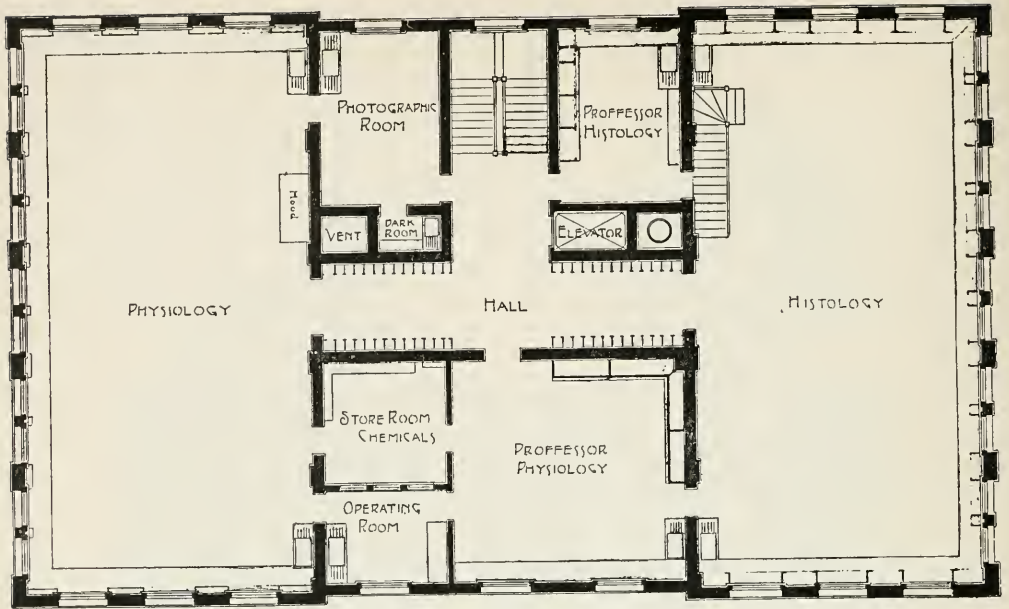

PLAN OF THIRD FLOOR

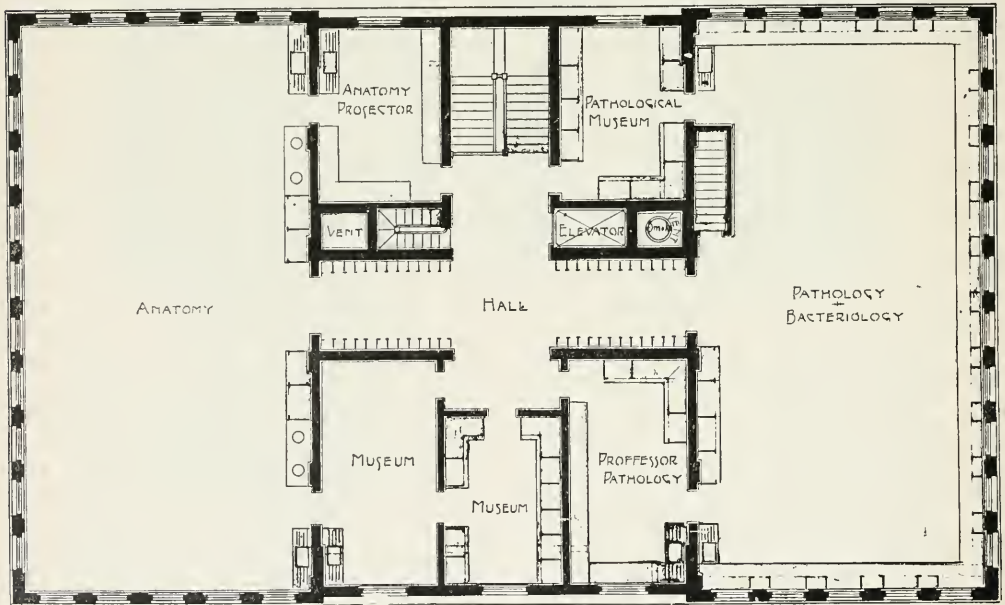

PLAN OF FOURTH FLOOR

FLOOR PLANS OF LABORATORIES, MEDICAL DEPARTMENT, SYRACUSE UNIVERSITY.

shaped to represent actual sections of the cord or brain. These are colored, so as to differentiate the tissues forming the cord or brain at that point.

The whole apparatus being constructed on a very large scale, makes it comparatively easy for the student to understand the relative arrangement of the nerve tracts and their courses, as well as their relation to each other, and to other parts of the brain.

Minutes of Meeting of the American Microscopical Society, held at Syracuse, N. Y.
August 30, 31, Sept. 1, 1898.*

Tuesday, August 30, 1898, 10 A. M.

Meeting was opened by Dr. A. Clifford Mercer, who introduced Professor Chas. W. Hargitt. He delivered an address of welcome in behalf of the Syracuse Academy of Science. Professor John Van Duyn was then introduced by Dr. Mercer,

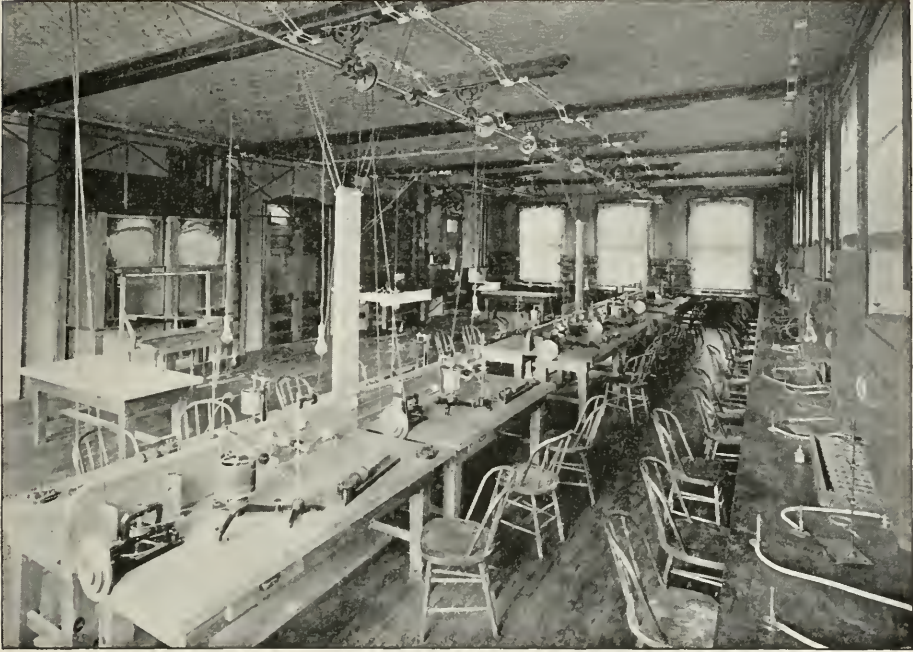

Physiological Laboratory, Medical Department, Syracuse University.

The Syracuse Medical College admits women to its courses, and while it has as yet only very few female students, it has made a special provision for their comfort, in the fitting up of a special women's study for their exclusive use. A photograph of this study is reproduced as a suggestion to medical colleges in general.

While each of the departments is provided with a set of reference books for immediate use, the general medical library is located on the first floor of the building, and arranged in fireproof book cases, as shown in the illustration. This method permits the storing in accessible form of a very large number of volumes in a very limited space.

The following report of the meeting is taken from the report of the secretary.

who welcomed the society on behalf of the Medical college of Syracuse. The acting president responded on behalf of the society, after which he declared the meeting ready for business.

In absence of the secretary, Dr. W. C. Krauss, detained by sickness, Magnus Pflaum was appointed acting secretary.

The executive committee recommended the following for membership:

Miss Mary Amanda Dixon Jones, New York city.

Dr. Henry D. Didema, Syracuse, N. Y.

Dr. F. W. Higgins, Cortland, N. Y.

Mr. Luther B. Elliott, Rochester, N. Y.

Dr. J. W. Mobley, Milledgeville, Ga.

*Mr. Magnus Pflaum has kindly furnished this manuscript in advance of his report. We are indebted to Dr. A. C. Mercer, Dr. I. H. Levy and Dr. W. H. May, for information regarding the medical college.



Histological Laboratory, Medical Department, Syracuse University.

Professor Charles Fordyce, University Place, Neb.

Professor G. E. Condra, Lincoln, Neb. All of whom were duly elected as members.

A biography of the late president, Professor D. S. Kellicott, prepared by Dr. A. M. Bleile, was read by the secretary.

Biographies of Professors William A. Rogers and H. C. Coon, prepared by Professor S. H. Gage, were read by Dr. A. C. Mercer.

PAPERS PRESENTED.

"Special Structure Features in the Air Sacks of Birds," read by Miss Mary A. Ross, A. B. Discussion by Dr. Moore and Professor Hargitt.

"A report of a Student's Work in the Micrometry of the Blood Corpuscles of Individuals of Different Nationalities," read by Dr. Moses C. White. Discussion by Dr. Higgins and Magnus Pflaum.

"Teaching of Correct and Definite Methods in the Use of the Substage Condenser," a demonstration by Dr. A. C. Mercer, was interesting and instructive.

President appointed Burton D. Myers and L. B. Elliott auditing committee.

Two o'clock P. M.

PAPERS PRESENTED.

"Method for Preparing Nucleated Blood in Bulk for Class Demonstration," by Dr. T. B. Oertel, read by L. B. Elliott.

"History of the Toad Tadpole's Tail," by B. F. Kingsbury, Ph. D., read by C. M. Mix.

"Use of Picro-Carmine and Alum-Carmine," by B. D. Myers.

"Rapid Staining and Washing Apparatus," a demonstration by C. M. Mix.

"Photo-Micrography with Opaque Objects," by W. H. Walnesley, read by Dr. A. C. Mercer.

"The Business Management of Laboratories," by Mr. L. B. Elliott.

"Microscopic Examination of Legal Documents," by Dr. George E. Fell.

"Some Laboratory Apparatus for Histology," by Professor S. H. Gage.

"An Occurrence of Albino Eggs of the Spotted Salamander, *Amblistoma punctatum* L.," by Mr. Horace W. Britcher, of Syracuse, N. Y.

Tuesday, 8 P. M.

At new hall of University Block, Acting President Dr. V. A. Moore delivered the annual address, after which was held an informal reception on invitation of the Citizen's club of Syracuse at their rooms in the University Block.

Wednesday, August 31, 10 A. M.

On recommendation of executive committee, Mr. Henry R. Howland, A. M., was elected to membership.

The president appointed as nominating committee: Dr. Raymond C. Reed, Dr.



Bacteriological Laboratory, Medical Department, Syracuse University.

A. M. Veeder, Mr. L. B. Elliott, Mr. Herbert R. Spencer and Dr. George E. Clark.

PAPERS PRESENTED.

"Notices of Some Undescribed Infusoria from the Fauna of Louisiana," by Mr. J. C. Smith.

"Experiments in Feeding Some Insects with Cultures of Coma, or Cholera Bacilli," by Dr. R. L. Maddox.

"Questions in Regard to the Diphtheria Bacillus," by Dr. A. M. Veeder.

"Means and Methods for Giving Instruction in Bacteriology," by Raymond C. Reed, a demonstration.

"The Resistance of Certain Species of Bacteria in the Milk Ducts of Cows," by A. W. Ward, of Ithaca, N. Y.

"What Shall Be Taught in a Short Course in Bacteriology?" by Dr. Veranus A. Moore.

"The Comparative Value of Different Methods of Plankton Measurements," by Professor Henry B. Ward.

"Work Done in Lacustrine Bacteriology, 1896-1898," by Professor Henry B. Ward.

Afternoon, Wednesday, Aug. 31, 2 o'clock.

The afternoon was given to inspection of the Medical college, and the members were treated to a demonstration and examination of its various apparatus by the professors of the college.

Dr. Moses C. White gave a demonstra-

tion of "The Electric Projection Microscope in Histology, with a New Department in Objectives."

Wednesday, August 31, 8 P. M.

A Microscopical soiree was held at the Medical college.

Thursday, Sept. 1, 10 A. M.

PAPERS PRESENTED.

"New Discoveries in Cancer," by Miss Mary Amanda Dixon Jones, read by Dr. A. C. Mercer.

"New Triple Differential Stain," by Dr. C. W. Kellogg.

BUSINESS MEETING.

The treasurer reported all debts paid and a balance in the treasury.

The auditing committee not being present, Dr. A. C. Mercer moved that the treasurer's report, if acceptable to executive committee, be published. Same as to secretary's report. Carried.

The nominating committee reported:

For President—Dr. William C. Krauss, Buffalo, N. Y.

Vice-Presidents—Dr. A. M. Bleile, Columbus, O.; Dr. G. Carl Huber, Ann Arbor, Mich.

Secretary—Professor Henry B. Ward, Lincoln, Neb.; Magnus Pflaum, Esq., Pittsburg, Pa.

Executive Committee—Professor S. H. Gage, Ithaca, N. Y.; Dr. A. Clifford Mer-

cer, Syracuse, N. Y.; Dr. Veranus A. Moore, Ithaca, N. Y.

All of whom were duly elected by ballot. In the afternoon the members were treated to a carriage ride for a visit to the Syracuse water works and to the New York State Institution for Feeble-minded Children. The former was fully shown and explained by the superintendent, Mr. William R. Hill, the latter by Superintendent Dr. James C. Carson. The ride, and especially its purpose, were thoroughly enjoyed by the participants.

An interesting feature of the meeting, greatly appreciated by the members and visitors, was the exhibit of the latest production of Microscopes and Accessories, furnished by the Bausch & Lomb Optical Company, the Spencer Lens Company,

cannot sufficiently appreciate their services.

MAGNUS PFLAUM, Acting Secy.

The officers elected for the ensuing year are all earnest and practical workers and should receive the hearty support of all interested, to make the next meeting of the society even more interesting and helpful than the last.

The Spencer-Tolles fund was created for the purpose of enabling the society to offer a medal or other suitable reward each year for meritorious work in the improvement of the microscope or of microscopical technique. The following statement shows the present condition of this fund. Subscriptions to it should be sent to Mr. Magnus Pflaum, treasurer, 415 Grant street, Pittsburg, Pa.



Women's Study, Medical Department, Syracuse University.

and by Richards & Co. Also the exhibit of X-ray apparatus by the Edison Manufacturing Company received its full share of attention.

Thus ended successfully a meeting which, by reason of unexpected occurrences, seemed, until the last moment, most discouraging of results. The president, Professor D. S. Kellicott, who had suggested and on whose account Syracuse was chosen as the meeting place, and who undertook the preparations for the meeting, had died. The secretary, Dr. W. C. Krauss, became sick and, during a time when his services were most needed to ensure a good meeting, was near death's door. The whole burden of arranging the meeting was suddenly thrown on the shoulders of Dr. A. C. Mercer in charge of the local committee, and Dr. Veranus A. Moore, who became acting president. The society

SPENCER-TOLLES FUND.

Year.	Increase.	Total.
1855	\$60 20
1856	85 20
1857	95 20
1858	147 86
1859	223 86
1890	253 86
1891	292 58
1892	312 00
1893	330 06
1894	349 38
1895	372 27
1896	423 04
1897	469 03
1898	535 46

REPORT FOR 1897-98.

Amount reported at Toledo meeting.	\$496 03
Subscriptions	4 00
Dividends, Jan'y 1, 1898.....	22 65
Dividends, July 1, 1898	23 78
Cash from sale of proceedings.....	36 00
Increase during year, \$86.43	\$555 46

L. B. E.

A Rapid Staining Apparatus.

Methods of staining may be roughly arranged in three classes: staining in toto, staining the sections and carrying them through all the steps necessary previous to mounting them in balsam on the slides, and, finally, performing all the work of staining after the sections have been fastened to the slides.

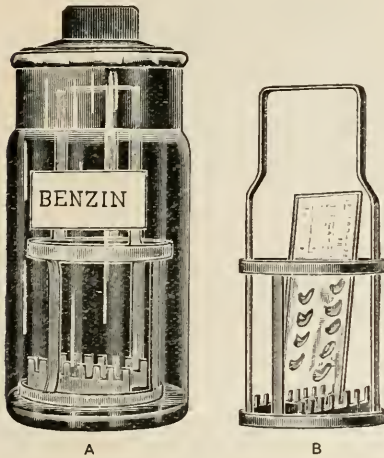

Fig. 1.

The first method is an excellent one, when small pieces of tissue are used. Large pieces would not be penetrated evenly by the staining agent. This method is very rapid; for the sections can be mounted directly from the knife

pieces of firm, homogeneous tissue, such as pieces of liver, are employed, and in case it is not necessary to preserve the continuity of the series of sections, good results may be obtained by placing the sections as soon as cut in watch glasses, filled with the proper reagents. By transporting them from one dish to another by means of a section lifter, or even by means of a glass rod, the sections may be carried through the various processes necessary to prepare them for mounting, before they are placed upon the slide at all.

This method is entirely inapplicable to serial work, as in embryological investigations for instance. Only firm structures could be treated in this way, for the more delicate ones would rapidly go to pieces, after the removal of the paraffin, without something to hold them in place. Even firm tissues are in great danger of being torn and distorted, or entirely destroyed, by being so often handled. Thus it appears that, for work in which delicate structures are involved or for pieces of considerable size, both the above methods fail.

To meet these difficulties, the method of staining on the slide has been resorted to. As applied in the laboratories of Cornell University, the method is as follows: the sections are fastened to the slide by means of a thin coat of albumen and heat, if embedded in paraffin, or by a drop of ether-alcohol, if collodion is used. After the removal of the paraffin or the oil by means of benzine or xylene, they are treated with ninety-five per cent alcohol. They are now ready to be

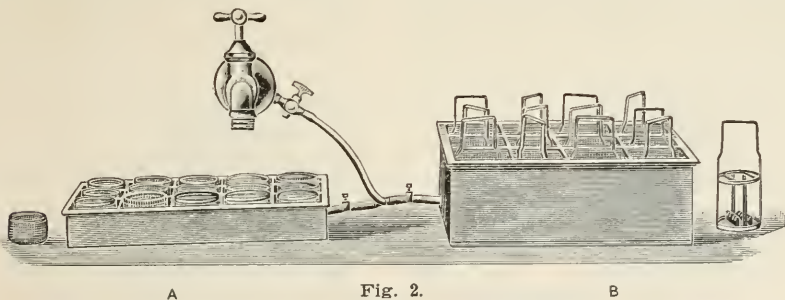

Fig. 2.

in Canada balsam after removing the paraffin, or, in case the object is imbedded in collodion, it is only necessary to remove the oil, dehydrate, clear, and mount. On account of the difficulties in securing good penetration of the staining fluids, this very efficient method has, we are loath to note, a rather limited application.

In most cases better results are obtained by staining after the sections are cut. As was suggested above, this result may be obtained in two ways. When

stained. The slides may now be placed either in the ordinary Stender dish, containing the staining agent, or laid flat on the rack (r, Fig. 5) over the waste jar (w, Fig. 5). In the latter case, the staining agents are poured upon the slides by means of pipettes. Excellent results are uniformly obtained in this way, in serial as well as single sections. Since the section is firmly fastened to the slide, the relative position of the different parts of the tissue is not changed, and the section does not become broken,

or lost. If several slides are placed in one of the Stender dishes at the same time, there is always danger of hitting them together and thus destroying the sections. This difficulty becomes particularly annoying in serial sectioning, where, of course, it is of the utmost

centimeters apart by four upright standard pieces of the same material. These upright pieces are arranged parallel to each other and at right angles to the rings. Two of them extend about six centimeters above the upper ring to form the handle. In this way we have a

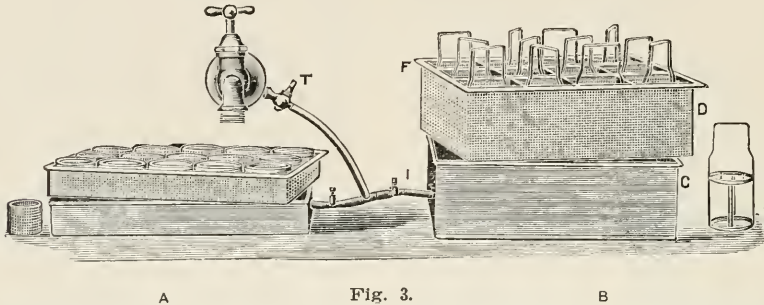

importance to preserve every section intact.

To hasten the process of staining on the slide and to reduce the danger of injury to the sections, the apparatus described below has been devised. By means of this device, fourteen slides can be stained in the time usually required for one, and the danger of injury to the section is entirely obviated. This apparatus was designed and its efficiency thoroughly tested in the laboratories of Cornell University.

The apparatus was designed primarily for work with Heidenhain's iron-hematoxylin, in the use of which, in order to obtain a permanent stain, it is necessary to wash the sections for some time in running water. Hence, with the essential part of the apparatus, there is com-

skeleton basket. Across the bottom ring extend two parallel pieces of brass, arranged at right angles to the handle. In the upper edge of each of these cross strips are seven notches, opposite each other, and of such a size as to receive, in each pair of notches, the ends of two slides placed back to back (Fig. I, a and b). These carriers are five centimeters in diameter and hold fourteen slides. They are made to fit a museum jar of convenient size, described above (Fig. I, a). Any vessel of convenient size might be used with carrier to match.

This jar for holding the reagents is the No. 2605 made by Whitall, Tatum & Co., New York City. It is listed in their catalogue as museum jar—diameter two inches; height to shoulder, three and three-fourths inches; height to top of

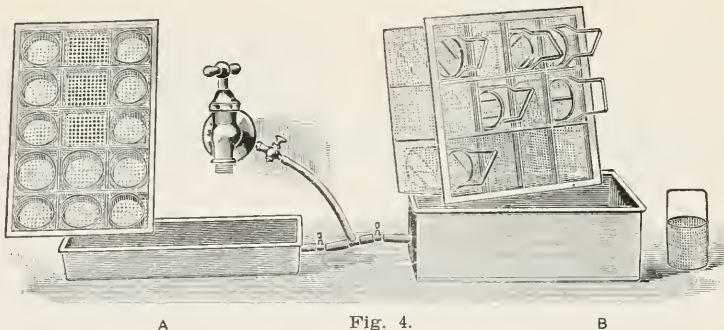

bined a washer, which will be described later. The principal part of this staining device is a carrier, or slide holder. It consists of two rings cut out of stiff sheet brass. The rings are about one-third of a centimeter in width and about five centimeters in diameter. They are held parallel to each other and about six

stopper, five and one-half inches; width of mouth, two inches. The handle of the carrier extends into the hollow stopper when the vessel is closed. These glass stoppers are ground to fit the necks of the bottles, so that the vessels are tightly closed, and in consequence evaporation is prevented.



Fig. 5.

The third part of this apparatus consists of a washer very similar in construction to and identical in principle with the tissue washer described by Prof. Gage in his article in the July Journal (Figs. 2, 3, and 4, b). The washer consists of two parts—an oblong brass box 24 centimeters long, 19 centimeters wide, and 9 centimeters deep (Fig. 3, c). At one of the lower corners is an inlet tube (i) to which is attached a piece of rubber tubing extending to the tap (t), from which is derived the supply of water. Inside this box (c), which is water tight, is a second box (d), made one centimeter smaller all around, so as to easily fit inside the first. From the upper edges of this inside box, there projects a flange (f), which rests upon the upper edges of the outside box. Thus a water space of about one centimeter is left between the outer and inner box. The inner box, unlike the outer one, is made of perforated brass and allows the water to pass freely through it. By means of five cross-partitions, which intersect at right angles, the perforated box is divided into twelve compartments, each six centimeters square (Fig. 2, c). Each compartment is large enough to hold one of the slide carriers. In this way a constant and gentle current is maintained, and the preparations do not become dislodged from the slides.

The slides, with the preparations attached, are placed in the notches back to back. Then the carrier with its fourteen slides is placed successively in the various reagents contained in the jars described above. When hematoxylin and some counterstain, as picro-fuchsin, are used, six jars are necessary to complete the outfit (Fig 5).

The advantages of this apparatus over the old method are obvious at a glance. The slides are not touched, either with fingers or forceps, from the time they are placed in the carrier until they are

removed from the clearer to be mounted. They are held in a stable position, so that it is impossible for the preparations to be injured by hitting against each other or the sides of the jar. By exercising a little care in lifting the carrier from the liquid, only the gentlest of currents is produced. In the hands even of an unskilled operator, the danger of injury to the sections is reduced almost to zero. Fourteen slides can be prepared with the labor incident upon the preparation of one by the old method. When a large number of slides is being prepared, it expedites matters to start a second carrier of slides as soon as the first carrier is removed from the first bottle, and so on until the whole number to be prepared is under way. This applies especially to serial work or the making of large numbers of duplicate slides for classes.

In a word, this apparatus, which, in its simplest form, need consist only of the carrier and the reagent jar, simplifies and makes available for wholesale preparation the best and most accurate method of staining, namely, the method of staining on the slide. It removes all danger of accident to the sections. The danger of distortion is reduced to a minimum. Great rapidity is obtained, and a complicated process is simplified.

A. B. MIX.

Cornell University.

Read at the twenty-first annual meeting of the American Microscopical Society, Syracuse, N. Y.

PLEASE FILL OUT THE BLANK
ON PAGE XIII.

Duplicate blanks with return postage will be mailed on request, as we intend to make the Directory as complete as possible. Send the names of all interested in the microscope.

Journal of Applied Microscopy.

Issued Monthly from the Publication Department
of the Bausch & Lomb Optical Co.,
Rochester, N. Y.

L. B. ELLIOTT, EDITOR.

Address all communications to
PUBLICATION DEPARTMENT,
BAUSCH & LOMB OPTICAL CO., ROCHESTER, N. Y.

One Dollar per Year. To Foreign Countries, \$1.25
per Year.

Entered at the Post-office, Rochester, N. Y., as second-class matter.

SEPTEMBER, 1898.

The series of articles by Dr. F. G. Novy, entitled "Laboratory Methods in Bacteriology," will be found particularly helpful to those physicians who desire to apply the microscope, in their daily practice, to those cases in which microscopical examination furnishes the most reliable means of diagnosis, and will in addition be an excellent outline for teaching these methods to those who are preparing themselves to become physicians. The simplicity and directness of the methods described commends them particularly to those whose object is rapid and accurate work.

BOOK REVIEW.

Laboratory Directions for Beginners in Bacteriology, by Veranus A. Moore, B. S., M. D., Professor of Comparative Pathology and Bacteriology and of Meat Inspection, N. Y. State Veterinary College, Cornell University, Ithaca, N. Y. Published by the author. Press of Andrus & Church, Ithaca, N. Y. 1898. pp. 89.

In view of the fact that courses of instruction in the elements of bacteriology have regularly been given during the last few years in nearly all the colleges, universities, and medical schools in this country, it is surprising that no thoroughly good set of laboratory directions adapted to the capacity of beginning students has hitherto been published. Numerous text-books, manuals, "lecture notes," and treatises of various kinds, dealing with bacteriology in general or with special branches of the subject, have appeared, but none confined entirely to elementary technique. There are doubtless, then, many teachers who will be glad that Dr. Moore has finally put the admirable "laboratory directions," used by his classes at Cornell University, into a form which makes them available for others.

This compact little pamphlet contains sixty elementary exercises, the performance of which will require of the earnest student about one hundred and fifty hours of actual laboratory work. In addition to the exercises themselves, the book contains a judiciously selected list of text and reference books, and of periodical literature, a page of "laboratory maxims" or precautions which the student must incorporate in his mental structure so thoroughly that he follows them unconsciously, and a list of apparatus and material for both general and individual use. That the exercises are eminently practical, may be seen from the following topics of study selected from the table of contents: cleaning glassware; plugging test-tubes and flasks and sterilizing the glassware; preparation of bouillon; inoculating tubes of bouillon, agar and gelatin; examination of cultures; making and staining cover-glass preparations, and formulae for staining solutions; examination of plate cultures and making sub-cultures from colonies; identifying genera among bacteria; studying and staining spores; staining the flagella of motile bacteria; staining tubercle bacteria (bacilli); making cultures of anaerobic bacteria; identifying genera of bacteria and obtaining pure cultures from colonies, and so on.

Besides these general exercises, whose object is to teach the student proper technique, there are many others devoted to the special study of some of the more important forms, including the *Bacillus coli communis*, *B. cholerae suis*, and *B. typhosus*, the bacterium (the author follows Migula's classification) of tuberculosis, of glanders, of anthrax, and of diphtheria. The Widal serum test is tried, bacteria are isolated from the animal tissues and identified, pus and exudates examined, the efficiency of disinfectants tested, milk pasteurized and sterilized, and qualitative examinations of water made. No animal experiments to be performed by the beginner are given. The student is constantly referred to standard literature for descriptions of the various operations involved in his work and the morphological and biological characteristics of the organisms studied. He thus becomes acquainted with many authorities besides the one who prepared his manual, and learns what has already been accomplished in the investigation of different bacteria.

The directions are in all cases clearly and briefly stated, and the student who has conscientiously performed these exercises may consider himself well equipped for advanced work.

CHARLES WRIGHT DODGE.

Rochester, N. Y.

Journal of Applied Microscopy.

VOLUME I.

OCTOBER, 1898.

NUMBER 10

Microscopic Work in Large Classes.

One of the great difficulties which confronts the science teacher in a city high school, is the large size of the classes.

The New York High School for Boys and Girls is occupying for the present a former grammar school building. The physiology laboratory is a room 20x22 feet. Along one side, lighted by two east windows, is a row of tables which provide space for six to ten compound microscopes. In the remaining limited space of the room four rows of single desks accommodate twenty-four pupils. Our classes number thirty-six to forty. Two of the aisles are provided with chairs for the extra pupils. The students are thus crowded into two solid masses, leaving a central aisle and an aisle at each side. In spite of these difficulties, however, laboratory work has been done in class throughout the year, and the microscope has been almost constantly in use.

Our equipment for microscopic work in botany, zoology, and physiology is the following: Twenty-four compound microscopes, each provided with coarse and fine adjustment, double nose-piece, two-thirds inch and one-sixth inch objectives, and two inch and one inch eyepieces; six sets of physiological slides; paraffin bath; Minot microtome; stains and reagents.

Two periods per week throughout the year are assigned to the subject of physiology in our course of study. The first exercises of the year are devoted to the study of the parts and the use of the compound microscope. Each pupil makes a drawing of the instrument, labeled in detail. In a Laboratory Manual of Anatomy and Physiology, prepared for our high school classes, published by Henry Holt & Co., is a list of rules for the use of the low and high-power objectives, and a statement of the

magnifying power of various combinations of objectives and eyepieces. Each pupil learns these rules and applies them at the microscope.

The method pursued in the study of the blood is typical of the work of the course. Six compound microscopes are placed in position on the tables, and a slide of amphibian corpuscles (double stained and mounted in balsam) is placed in focus beneath the high-power objective of each instrument. The pupil takes to the microscope his note-book, a pencil, and the following laboratory directions:

Microscopic Study of Corpuscles of Frog's blood:

1. How many distinct types of solid bodies (corpuscles) can you see in the frog's blood?

2. Is there any variation in the form or size of different corpuscles of the same type?

3. Draw two corpuscles (differing as much as possible) of each type, much enlarged, labeling nucleus and cell body.

The drawings are made on a page in the note-book while the pupil is at the microscope; the answers to the questions are written as soon as he has taken his seat. Each drawing is submitted to the instructor as soon as completed, for suggestion or criticism, and when important structures have not been represented the pupil returns to the microscope for further study. Twenty to thirty minutes suffice for each pupil in a class of thirty-six to make a satisfactory drawing of the corpuscles.

As a means of correcting false observations and of suggesting further points of instruction, photo-micrographs of similar corpuscles are distributed, which the pupil compares with his own drawings.

Having completed the study of the frog's corpuscles, a comparison with hu-

man corpuscles is easily made. The pupils pass rapidly to the microscopes, remaining long enough to obtain information sufficient to answer the following questions found in the Laboratory Manual.

Microscopic Study of Human Corpuscles.

1. What is the form of the corpuscles in human blood? (Examine several corpuscles before deciding.)

2. In what respects do these corpuscles differ from those found in frog's blood?

Ten to fifteen minutes will be required for this work. Before the close of the hour the answers to the questions are reviewed, corrections being made in the note-books by each pupil.

Since but a small number can work at the microscopes at one time, certain definite work must be outlined for the rest of the class that the teacher may give his full attention to directing the microscopic work. Diagrams may be drawn from the board in the note-book and labeled; charts may be copied; dictation exercises or review outlines may be taken down.

An experience of several years has demonstrated that a large amount of successful microscopic work can be accomplished in large classes, even in a short recitation period, by careful planning on the part of the teacher.

JAMES E. PEABODY.

The High School for Boys and Girls,
Third Ave and 157th St., New York
City.

Picro-Carmine and Alum-Carmine as Counter Stains.

The following paper, presented before the American Microscopical Society during its recent meeting at Syracuse, with slides illustrating the effectiveness and superiority of the stains, is here published at the request of the editor.

The paper embodies the results of experiments with picro-carmine and alum-carmine* as counter stains, as developed incidentally during the year in the histologic laboratory at Cornell University.

The excellence of picro-carmine was first noticed last November, in staining developing bone which had been decalcified. Picro-fuchsin† was being regularly used as a counter stain with hema-

toxylin. Merely for the experiment, picro-carmine was used on one section and left nearly two hours. Much to our surprise and pleasure we found, instead of our section being ruined, that we had secured an excellent differentiation. This was not the first attempt with picro-carmine, but always before the time had been short, from two to fifteen minutes.

The advantage of the stain over picro-fuchsin is noticeable in the superiority of differentiation secured as illustrated in the slides presented at the Microscopical Society.

The embryonal cartilage cells are better marked by the hematoxylin and picro-carmine, for the alkaline picro-carmine does not fade the hematoxylin as does the acid picro-fuchsin.

It is particularly in the zone of calcifying cartilage that this superior differentiation is noticed. The vertically arranged rows of cartilage cells have lost their horizontal septa, but the vertical septa are pronounced and project into the primary marrow cavity as irregular trabeculae of calcified cartilage. The osteoblasts have enveloped these trabeculae with a covering of true bone and at the same time the cartilaginous trabeculae within are being absorbed and true bone substituted.

This true bone, with the picro-carmine, has taken a red which is brilliant in comparison with the picro-fuchsin; and the gradually diminishing and disappearing cartilage which, with picro-fuchsin, has taken a stain not distinguishable from that of the cells of the true bone is, with picro-carmine, beautifully differentiated by a clear pronounced blue, showing the alkalinity of the picro-carmine.

This tendency on the part of picro-carmine to bring out the hematoxylin as a blue, while the acid picro-fuchsin fades it, is very noticeable in the tonsil of dog which was next submitted. In the mucous cells near this gland the nuclei, removed as far as possible from the lumen, are brought out with unequalled clearness. The structure of the blood vessels is also brought out with great distinctness, and the differentiation throughout is very marked.

Quite as striking a contrast between picro-carmine and picro-fuchsin is noticed in a section of the pyloric stomach of a kitten. The stain with picro-carmine is not only more differential, but the unstriped muscle of the stomach and blood vessels is brought out much better by the picro-carmine.

During the summer picro-carmine was tried with good results on the fallopian tube of a mare. It has been used with greatest success on tissues which present a mucous surface, and while these

*For literature, see Lee's *Vade Mecum*, and the most recent publication on the subject by P. Mayer, *Ueber Picro-carmine*. *Zeitschrift für Wissenschaftlichen Mikroskopie*. Vol. XIV., pt. I., p. 18.

†See Freeborn, *Trans. N. Y. Path. Soc.*, 1893, p. 73. Also, *Studies from the Dept. of Path. of the College of Physicians and Surgeons, Columbia University, N. Y. 1894-'95*.

successes have been noted, an equal number of failures were encountered, so no claim is made for picro-carmin as a "pan" stain. It seems particularly unsuited for tissues that stain with difficulty.

Ranvier's picro-carmin was used in most of these experiments, but Bizzozero's was used with equal success. Mayer's recent formula was used in the histologic laboratory at Cornell last year with results quite as good as those from Ranvier's.

In summary, then, we find picro-carmin, in the cases noted, gives, with hematoxylin, a more differential stain than picro-fuchsin and shows the characteristic alkaline reaction with hematoxylin, bringing out the hematoxylin as a beautiful sharp blue, while the acid picro-fuchsin tends to fade it. Two hours is, in general, the best time for picro-carmin. There is no danger of overstaining.

ALUM-CARMINE.

During the summer it was my privilege to prepare some slides of liver of guinea-pig to show Anthrax bacilli. The bacilli were readily found, and, at the request of Dr. Moore, pathologist and bacteriologist of the New York State Veterinary College, I attempted to get a contrast stain, and finally succeeded with alum-carmin. I had tried picro-carmin without success. In fact I have never been able to secure a good stain with picro-carmin on liver. By experiment I found that one hour and fifty minutes with alum-carmin gave the best results. The crystal-violet with which the bacilli were stained, and which is washed out much or entirely by the alcohols and clearer, must be sufficiently intense to permit of thorough dehydration and clearing and yet leave a distinct stain. One and one half minutes will suffice if care is taken not to leave longer than necessary in alcohol.

By this stain the nuclei and cell body are clearly differentiated and the alum-carmin forms a very good contrast stain with the crystal-violet. The simplicity of the method commends it to us. It is suggested that with methylene blue a still greater contrast may be secured.

B. D. MYERS, PH. B.

Cornell University, Sept. 12, '98.

Note—I wish to acknowledge my indebtedness to Dr. Kingsbury for suggestions received during the year, regarding the use of picro-carmin.

Peroxide of hydrogen will so bleach and clear many insects that the respiratory system and other organs can be clearly seen.

Laboratory Methods in Bacteriology.

DR. F. G. NOVY, Ann Arbor, Mich.

II.—Detection of Pathogenic Organisms.

The effort was made in the preceding paper to indicate to a beginner the methods of examining bacteria in the living condition and in stained preparations. As in every line of work, practice is necessary in order to obtain the best results. It is well, therefore, to devote extra time to the mastery of the simple methods already described. This preliminary practice is essential to the successful application of such methods as aid in the diagnosis of disease.

The present paper deals with the recognition of the more common disease-producing organisms, by means of the staining reactions. The methods indicated are therefore of practical value in diagnosis. The utmost detail is given, because the object in view is to assist and encourage those who have not the direct aid of an instructor.

GONORRHOEA.

The cause of this disease is an extremely minute spherical germ or micrococcus, known as the gonococcus. It is found almost invariably in pairs. The two cells in that case are not perfectly round, but are slightly flattened on the apposed surfaces. The appearance is not unlike that of two biscuits with the flat surfaces brought together.

The gonococcus is frequently found in groups of ten, twenty, or more pairs. These groups will be found outside of the pus cells. Again, almost invariably some of the pus cells will be found to contain a large number of these minute organisms. Anywhere from five to fifty or more pairs of gonococci will be seen inside of some of the pus cells.

The characteristics to be borne in mind when seeking this organism are: (1) Minute spherical bodies, flattened somewhat when they are brought together in pairs; (2) the tendency to form in groups between the pus cells; (3) the presence of the gonococcus inside of some of the pus cells.

Detection.—A drop or two of the suspected pus is transferred from the urethra to a clean watch glass or to a glass slide. A drop of water should be added to the material and the whole mixed thoroughly with a platinum wire. The water serves to dilute the material, and moreover retards evaporation. It is desirable to examine the pus collected on the first or second day of the disease. In old cases, the secretion may contain

but few of the gonococci, and these may be associated with other germs.

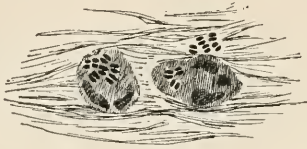

Gonococcus.

By means of a looped platinum wire, a portion of the mixture is transferred to a clean cover-glass and spread over as much of the surface as possible. When the specimen has dried in the air it is taken up with a pair of forceps and fixed in the flame. Overheating must be avoided, since it interferes with the proper staining of the germs. Usually, a single passage through the flame will be sufficient to fix the specimen to the cover glass, so that it will not wash off during the subsequent manipulation.

The fixed specimen, held in the forceps, is then covered with a dilute solution of methylen blue. In about one-third to one-half minute the dye is washed off, the under side of the cover glass is wiped clean and dry, and finally the cover glass is inverted onto a clean glass slide. A little water should be present between the specimen side of the cover-glass and the glass slide.

The preparation is now ready to be examined under the microscope. The gonococcus can be seen with the one-sixth or one-eighth-inch objective, but it is advisable for the beginner to employ, if possible, the one-twelfth oil-immersion objective. Even with this lens the organism will appear as very minute points or dots, which may easily be overlooked. The observer will notice, first of all, the large round cells. Within each of these cells there will be usually seen one or two large bodies which are stained a deep blue. These are the nuclei, and the cells themselves are the pus cells. The gonococci are vastly smaller than these pus corpuscles. On careful examination groups of the dot-like gonococcus will be found either between the cells, or in some cases within the pus cells.

The methylen blue is prepared as follows: A saturated alcoholic solution of the dye is first prepared. This will keep indefinitely and can be kept therefore in stock. One part of this strong solution should be diluted with three to four parts of distilled water. This dilute dye will keep for some time, and it is that which is used for staining purposes.

Löffler's methylen blue solution is excellent for staining gonococci as well as the diphtheria bacilli. It does not

deteriorate on keeping. It is prepared by adding 30 cc., of the saturated solution of methylen blue to 100 cc. of a 0.01 per cent. solution of potassium hydrate.

DIPHThERIA.

True diphtheria is due to the Löffler bacillus, whereas certain diphtheria-like conditions of the throat are due to other organisms. Inasmuch as the dangerous form of clinical diphtheria is that due to the Löffler bacillus, and further, since antitoxin is of value only in true diphtheria, it is evident that the recognition of the cause of this disease is essential to its correct diagnosis and treatment.

The Löffler bacillus is especially present in the false membranes which form on the mucous surfaces of the throat. A portion of the membrane can be removed with a blunt instrument such as a spatula, or better by means of a cotton swab. This is prepared by rolling a tuft of cotton over the end of a stout wire or stick of wood. If the material removed is to be used for growing the bacteria present, it must of course be sterilized before hand. For this purpose the swab is placed in a test-tube, the mouth of which is then plugged with cotton. The tube is then heated in a dry-heat oven at 150 degrees C. for at least one-half hour.



The Löffler Bacillus.

The diagnosis of diphtheria can be made by the direct examination of the false membrane. It is advisable, however, to supplement the preliminary examination by transplanting some of the material to a tube of sterile blood-serum. The sterile swab should be rubbed firmly over the affected surface and then rubbed over the surface of the serum. The culture tube should then be set aside in a warm place, preferably in an incubating oven which is kept at the temperature of the body. In from eighteen to twenty-four hours numerous colonies develop on the blood serum. Sterile swabs and blood-serum tubes can be purchased on the market and several of the sets should always be kept on hand.

A portion of the membrane removed from the throat can be rubbed thoroughly over the surface of a cover-glass. The latter should then be fixed by passing through the flame, and finally stained with either of the methylen blue solutions mentioned above under "Gonorrhoea."

Simple stains with methylen blue should be made from the colonies that develop on the blood serum. The preparation of these specimens is exactly the same as described in the first paper.

The Löffler bacillus appears as a distinct rod, which may be straight or slightly curved. Very frequently the rods will be seen to be slightly swollen either in the middle or at one end. Consequently spindle or club-shaped forms are to be expected. The behavior with methylen blue is very characteristic. The dye may stain the bacillus evenly, but more often it will be found to stain irregularly. Sometimes transverse bands will be stained alternating with lighter portions; at other times the bacterial cell will contain one or two round or oval bodies, which take a very deep blue stain as compared with the rest of the cell. These blue dots therefore stand out in bold relief.

The recognition of the Löffler bacillus, therefore, depends upon the peculiar form and upon the behavior to the stain. These characteristics may be seen with the one-sixth or one-eighth-inch objective, but the beginner will do well to employ the one-twelfth-inch oil-immersion objective in order to make certain of the result.

TUBERCULOSIS.

Tuberculosis is by far the most important bacterial disease which attacks man. The disease ordinarily affects the lungs, but it may involve other organs. The examination of sputum, pleuritic exudates, pus, urine, and milk may in suspected cases reveal the presence of the tubercle bacillus and thus establish the nature of the disease. If there is any part of bacteriology that can and should be included by every physician in the usual routine method of diagnosis, it is the recognition of this organism. The method is simple and easy of execution and an abundance of material can always be secured for the purpose of practice.

The sputum of a consumptive should be employed by the beginner. It should be collected in the morning, immediately after rising, inasmuch as at this time it is likely to be rich in bacteria. The matter coughed up later in the day may be largely diluted with saliva, and consequently is not as satisfactory for the purpose of examination. Indeed, care must be taken at times to instruct the patient that sputum and not saliva or mucous is what is wanted.

The sputum should be poured out into a wide glass dish, and carefully examined for the presence of small yellowish or whitish particles. These are portions of

caseous matter from the lung and are likely to be rich in bacteria.

The cheesy particles should be transferred to a cover-glass and thoroughly smeared over the surface. In the absence of definite particles, a portion of the sputum should be spread over the cover-glass. It is advisable to take a large loopful of the sputum, inasmuch as the tubercle bacillus can be recognized, even in the presence of considerable foreign matter. If the organism is present in small numbers it can therefore be easily overlooked, unless a sufficient amount of material is present.

The cover-glass smeared with the sputum is allowed to dry in the air. The operation may be hastened by gently waving the specimen at some distance over the flame. When dry the cover-glass is fixed by passing once or twice through the flame. Over-heating will destroy the staining power of the germ, whereas if the specimen has been insufficiently heated the material will wash off during the process of staining. It is well, therefore, to ascertain by repeated trials the amount of heat necessary to apply to a specimen in order to fix it.

The specimen, held in the forceps, is covered with Ziehl's Carbolio-fuchsin solution and held a few inches above a low flame, so that vapors are slowly given off. When the liquid has partly evaporated, an additional drop or two of the stain should be added. This should be repeated several times if necessary. The specimen should be heated thus for one to two minutes, special care being taken to prevent the dye from drying down on the cover-glass.

The excess of dye is then washed off with water and the specimen is placed in dilute nitric acid for ten to fifteen seconds. This dilute acid solution is prepared by adding three or four drops of the concentrated acid to a watch-glassful of water. The specimen is then transferred to a dish containing dilute, sixty to seventy per cent., alcohol. By gently tilting the dish or by moving the cover-glass the decoloration of the specimen can be hastened. If the color does not wash out readily, the specimen may be immersed again for a few seconds in the nitric acid solution. Care must be taken not to allow the acid to act too long, inasmuch as it tends to remove some of the dye from the tubercle bacillus. It is better to allow the alcohol to do most of the decoloring, in which case the tubercle bacillus will be deeply stained and rather thick in appearance.

The washing with alcohol is stopped when the specimen has acquired a light pink color. When masses of tubercle bacilli are present these will of course retain a bright red color. Such masses

of germs are not commonly met with, and hence as a rule the specimen can be washed until it is almost colorless.

The specimen is then rinsed with water, and covered with dilute methylen blue solution. This is allowed to act for about one-half minute and is then washed off with water. The cover-glass is then drained, the under side dried with a piece of filter paper, and finally inverted onto a clean glass-slide. It can now be examined with the one-sixth or one-eighth-inch objective, but as a rule the one-twelfth oil-immersion is more satisfactory.

If the process has been carried through properly, the tubercle bacilli will appear as bright red rods on a blue background. The ordinary bacteria that may be present are stained likewise blue. It is evident, therefore, that the tubercle bacillus differs from the common bacteria in its behavior to the staining reagents. It is very slowly stained by the simple dyes, and for that reason a special strong stain, Ziehl's carbolic fuchsin, is employed. On treatment with acid and alcohol, the common bacteria are readily decolorized, whereas the tubercle bacillus, which is with difficulty penetrated by the dye, is likewise with difficulty decolorized. For this reason on treatment with a contrast color like methylen blue, the background and common bacteria appear blue, whereas the tubercle bacillus remains red and is thus brought out in sharp relief.

The tubercle bacillus is a rather long narrow rod. It is usually single or in pairs, and only occasionally will three or four cells be found in a thread-like form. The bacilli are usually found in groups or aggregations. As a rule, the rod is evenly stained, but at times it may show a beaded structure. The bacillus in this case appears as a row of dots.

The carbolic-fuchsin is prepared by adding one gram of fuchsin and 13 cc. of absolute alcohol to 100 cc. of a five per cent. solution of carbolic acid. The mixture should be heated until perfect solution results. This solution does not keep indefinitely. It deteriorates on standing for some weeks, and for that reason it is advisable to prepare from time to time a perfectly fresh solution.

This can best be prepared in small quantity in the following way: Dissolve eight grams of fuchsin by the aid of gentle heat in 100 cc. of strong alcohol. This is a stock solution of fuchsin which will keep without change. A deposit may form on cooling, and hence before measuring out the liquid it should be warmed till the dye has dissolved. One gram of fuchsin is contained in 12.5 cc. of this solution. By adding 3.1 cc. of this solu-

tion to 25 cc. of the five per cent. carbolic solution, and warming gently, a very good carbolic-fuchsin solution will be obtained.

Occasionally sputum, pus, or other products of disease will not reveal the tubercle bacillus when stained in this way. Either the germ is present in a spore-like condition, or it is present in very small numbers and thus escapes detection. In such cases it is necessary to resort to an animal experiment in order to establish the diagnosis. For this purpose some of the material is injected into the peritoneal cavity of a guinea-pig. In three or four weeks the animal is killed, and if, on post-mortem examination, tubercular nodules are found in the abdominal cavity they should be examined for the tubercle bacillus. A portion of the cheesy matter from the inside of the nodule should be used for the examination.

The following summary will be of value in staining for the tubercle bacillus:

Cover-glass preparation,
Dry in air,
Carbolic-fuchsin (hot 2 min.),
Water,
Dilute nitric acid (10-15 sec.),
Alcohol, 60 per cent.,
Water,
Methylen blue ($\frac{1}{2}$ min.),
Water, and examine.

If it is desired to preserve the specimen it should be allowed to dry in the air, or by gently moving it to and fro over a flame. A drop of Canada balsam is placed in the center of a clean glass slide, and the inverted cover-glass is then applied and gently pressed down upon the balsam.

ACTINOMYCOSIS.

This disease affects cattle quite frequently, and only occasionally man. It is commonly known as lumpy-jaw. The nature of the disease can be established by an examination of the pus taken from the nodules or swellings. When this pus is spread out in a thin layer it will show extremely small yellowish granules. If these are placed on a slide, covered and examined with a one-sixth or one-eighth-inch objective, they will be found to be bunches of club-shaped rods or threads, radiating from a given point. It is because of this appearance that the organism is designated as the ray-fungus, actinomyces.

University of Michigan.

(To be continued.)

Please forward your name for the Journal Microscopical Directory.

A Study of Various Styles of Cross-Wires.

In making a measurement with a filar micrometer, spectrometer, sextant, and a variety of other instruments, the principal difficulty one encounters is in the setting of the cross-wires. There are several methods employed to make these settings as accurate as possible, and as the purpose of the work described in this paper was to test their relative efficiencies, I will describe them at once. By reference to the figure it will be seen that A consists in setting the point common to two crossed wires over the given fixed line; B is when one wire is superposed on the line; in C this line bisects two parallel wires, and in D the reference line is at one side of the movable parallel wires and at a distance from one of them equal to their distance apart.

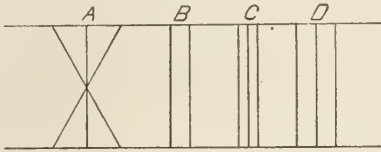

Styles of Cross-wires.

The problem of determining the most advantageous form for accurate settings is a psychological one, no less than a physical. Much depends upon the observer, the instrument, and the occasion. I made use of a micrometer microscope whose constant was 15.3: that is, 15.3 turns were equivalent to one millimeter. I then selected four observers, three of whom had done more or less work with instruments of this kind, and the fourth was entirely without experience. Observations were recorded in sets of twelve for each of the four methods, and tests were made in which the time of observation was limited to a definite period, usually two or three seconds. Another set of readings was taken in which settings were made by each method in turn, that is to say, the observer would follow methods A, B, C and D, and then go back to A.

It was attempted to make the external conditions, such as the light, the time of day, the condition of the instrument, etc., as nearly uniform as possible. After the settings had been made, the "probable error" of each group was computed. The probable error of the mean of a set of observations is a term used in the theory of Least Squares to denote a number of which it can be said that the probability of the true result lying between the mean, plus this number and the mean, minus this number, is just

equal to the probability that it does not lie between these limits. Thus, if 61.8+0.6 represents the mean of a set of observations and its probable error, we may say that the true result is just as likely to lie between 62.4 and 61.2 as to lie beyond these limiting numbers. To deduce the probable error the following formula is used:

$$P. E. = 0.67 \sqrt{\frac{E_1^2 + E_2^2 + E_3^2 \dots E_n^2}{n(n-1)}}$$

when E, E², etc., represent differences between the mean and the separate observations, and n is the number of observations made. The following tables were made up from data which seemed to be typical of all the observations taken.

OBSERVER 1.

Time unlimited.				
Method.	A.	B.	C.	D.
Settings	56.7	49.0	75.9	29.0
	60.0	49.0	75.7	27.5
	59.5	50.6	77.1	26.6
	63.2	49.5	77.0	28.4
	60.9	51.0	75.2	28.0
	56.3	50.1	78.0	27.1
	56.5	49.5	77.7	26.5
	60.5	50.3	75.2	27.5
	58.7	51.6	75.7	24.8
	59.4	50.5	76.8	27.5
	59.4	48.3	76.8	25.4
	57.0	47.5	77.8	26.9
P. E.	0.42	0.20	0.21	0.23

Time limited.				
Method.	A.	B.	C.	D.
Settings	87.2	76.4	79.5	26.5
	84.5	73.0	76.0	27.5
	90.7	79.8	80.0	26.7
	90.6	81.4	78.5	24.0
	89.0	74.8	71.5	24.0
	87.4	76.5	78.5	23.0
	86.2	75.0	75.8	24.4
	81.7	75.6	76.0	24.8
	85.0	75.0	73.5	28.5
	84.3	75.0	75.8	24.0
	89.0	72.1	76.7	24.6
	81.0	75.8	73.2	24.6
P. E.	0.62	0.46	0.50	0.32

Each method in alternation.				
Method.	A.	B.	C.	D.
Settings	92.0	81.0	7.0	30.4
	88.5	81.8	7.8	34.4
	89.5	80.0	7.0	30.2
	91.0	81.1	7.0	29.1
	88.6	81.8	6.8	31.2
	89.5	81.8	4.8	28.6
	89.6	81.9	7.0	31.2
	89.3	83.0	7.9	29.5
	89.8	80.0	6.9	28.6
	91.6	83.0	5.5	29.0
	88.6	82.8	7.0	29.6
	89.3	82.7	7.5	31.2
P. E.	0.22	0.21	0.18	0.32

OBSERVER 2.

Time unlimited.				
Method.	A.	B.	C.	D.
Settings	91.5	82.0	8.5	30.8
	91.1	84.0	9.0	31.1
	92.9	82.0	8.6	30.7
	92.0	82.1	9.1	32.2
	93.0	82.0	9.0	33.5
	93.2	83.0	8.9	32.8
	93.8	82.6	9.0	30.0
	92.1	84.0	7.8	32.1
	93.6	84.0	9.0	31.5
	93.0	83.0	8.9	30.9
	94.3	82.9	9.9	30.5
	94.2	84.0	9.0	30.0
P. E.	0.20	0.17	0.10	0.17

Time limited.				
Method.	A.	B.	C.	D.
Settings	96.8	82.0	11.5	34.2
	92.5	83.0	12.2	34.1
	93.1	86.5	10.9	32.5
	99.9	82.5	11.4	28.0
	94.2	84.4	12.0	28.5
	93.5	84.4	8.8	37.2
	89.7	85.5	10.1	31.6
	93.9	83.0	8.8	30.8
	98.0	84.6	9.0	30.0
	96.6	84.0	11.1	29.9
	91.2	80.6	10.0	34.9
	93.9	82.0	9.0	31.3
P. E.	0.49	0.28	0.25	0.54

Each method in alternation.

Method.	A.	B.	C.	D.
Settings	97.0	86.9	11.8	31.5
	95.0	84.2	10.8	30.9
	91.5	84.1	9.8	30.2
	95.0	86.2	9.0	32.8
	92.6	83.6	10.5	31.2
	95.6	85.2	10.8	30.4
	95.5	85.2	10.3	33.0
	97.4	84.9	10.3	31.9
	95.8	85.0	10.2	32.0
	95.7	83.5	10.9	31.8
	94.6	84.0	10.8	30.5
	9.50	8.50	10.5	30.0
P. E.	0.26	0.19	0.12	0.19

OBSERVER 3.

Time unlimited.				
Method.	A.	B.	C.	D.
Settings	81.5	19.5	89.0	80.0
	78.0	23.0	87.5	77.5
	76.0	21.5	88.0	80.0
	76.5	21.0	89.5	77.8
	77.8	19.8	91.2	78.5
	81.5	22.5	87.5	81.0
	74.0	22.0	89.5	80.2
	74.5	23.2	92.0	80.5
	79.0	22.0	92.5	78.0
	78.5	22.5	91.5	80.0
	81.2	23.0	91.0	78.5
	78.2	22.8	91.4	79.8
P. E.	0.39	0.23	0.35	0.23

As might have been expected, an inspection of these tables does not indicate any single method as possessing decided advantages. The personal equation is a very important factor. There are certain conclusions, however, which

Time limited.

Method.	A.	B.	C.	D.
Settings	87.2	33.0	8.0	87.0
	92.5	32.8	5.2	88.5
	88.0	31.0	7.5	85.2
	89.8	35.5	4.0	87.8
	89.0	30.0	6.5	86.0
	89.5	32.0	9.0	91.2
	88.5	30.0	7.5	8.48
	89.0	32.5	4.0	92.0
	94.0	30.5	6.5	91.5
	93.5	30.0	7.0	87.5
	92.0	30.5	5.2	89.0
	93.5	35.0	5.8	89.8
P. E.	0.46	0.37	0.30	0.33

Each method in alternation.

Method.	A.	B.	C.	D.
Settings	90.0	32.5	3.5	89.0
	93.5	34.2	7.2	88.8
	96.8	30.0	5.0	88.2
	93.0	34.2	5.5	86.5
	91.0	29.0	6.8	85.8
	94.5	29.0	5.8	80.8
	92.2	33.2	6.0	86.0
	97.0	32.0	5.0	88.8
	92.2	33.5	7.5	88.2
	93.5	33.0	5.2	90.0
	94.5	33.8	8.8	90.2
	96.2	36.0	3.8	90.5
P. E.	0.45	0.42	0.76	0.12

OBSERVER 4.

Time unlimited.				
Method.	A.	B.	C.	D.
Settings	12.0	88.9	13.8	32.6
	11.3	88.3	14.1	29.3
	9.0	88.1	14.5	34.7
	10.3	89.1	13.8	34.8
	7.8	88.0	13.0	37.2
	4.7	89.6	15.0	37.3
	8.0	90.0	14.8	33.4
	9.8	87.9	14.6	37.2
	15.0	87.8	14.2	36.1
	11.7	86.8	14.2	37.6
	8.1	88.0	15.1	33.0
	9.4	88.4	14.0	36.7
P. E.	0.51	0.09	0.11	0.49

Each method in alternation.

Method.	A.	B.	C.	D.
Settings	8.1	86.0	15.0	35.9
	8.4	87.4	14.6	36.6
	7.4	88.4	14.1	35.0
	10.3	89.1	14.0	37.7
	11.3	88.5	14.5	36.7
	10.0	88.7	13.4	33.0
	7.4	88.2	13.2	34.0
	9.7	86.2	11.1	31.2
	6.8	89.0	14.1	36.7
	7.2	85.2	10.2	32.3
	4.3	85.0	14.9	33.3
	5.0	86.3	11.3	30.0
P. E.	0.46	0.29	0.31	0.48

it would seem may be drawn from this work:

1. With one exception, method A (intersecting wires) gave the largest probable error, and may easily be classed as the poorest method.

2. When the reference mark upon which the cross-wires are to be set is of about the same order of magnitude as the movable wire, the method of superposing one upon the other (B) gives the best results.

3. When the reference mark is larger, such, for example, as the lines on a graduated scale, methods C or D should be used. The choice between these methods depends upon the observer; if he has keen eyesight, he should set the parallel wires near the edges of the object observed (C); but for those who have the ability to make correct estimates of distances, method D will be found satisfactory.

JAMES S. STEVENS.

University of Maine.

American Postal Microscopical Club.

This club, after the usual summer vacation, is now entering upon its twenty-fourth year of successful operation. As is well known to the older class of microscopists, it holds no regular meetings, being wholly a correspondence society that circulates slides through the mails, and comments on the same, in order to interest the members in each other's work and ideas. From twelve to fifteen boxes of slides usually pass each member during the club season, from October to June. Besides postage on the boxes and letters, and a one dollar entrance fee, the dues are annually one dollar, and one slide with descriptive note. The membership is widely scattered over the various states. It is neither wholly professional nor yet practicable for persons wholly without experience or skill. It is open to those who are able and willing to be really useful members, whether great or small. Experts, who have much to teach and little to learn, would naturally regard it chiefly as a means of helping and encouraging their fellows. Any correspondence as to membership should be addressed to the president.

The following announcement, just issued to members, will give non-members some further idea of the methods of the club:

"As the circuits are now being revised, and corrected lists for the year's use being printed, notice of actual or expected changes of address should be forwarded at once; also intended proposals for new members.

"Collecting boxes for a new series of circuit boxes will be sent out, after a few weeks, by the secretary; and members are specially requested to have

their slides ready, with notes fully prepared, in order to avoid hasty preparation or interruption of the circulation while waiting for them.

"There are now a few scattering vacancies in the circuits, which it is desirable to have filled by the right persons at the present time; also one entire circuit that could be spared for a local section, but only on condition that some old member, familiar with the necessities of the club and with the proposed new members, would undertake the organization and supervision of the circuit, and be personally responsible for keeping it in good order. Members recommending candidates for membership should be careful to do so only on definite knowledge, and with the understanding that unquestioned ability to be a useful member is not more important than the assurance of being a safe one, having knowledge of the character of the work, a positive and permanent interest in the project, and both desire and opportunity to attend personally and promptly to the little duties involved."

R. H. WARD, M. D., President.

Troy, N. Y.

A Permanent Stain for Starch.

A very good and durable stain for starch may be obtained by the use of anilin-safranin and gentian-violet.

1. Anilin-safranin: alcoholic fifty per cent. solution, prepared by combining equal parts of anilin water and a saturated alcoholic ninety-five per cent. solution of safranin.

2. Gentian-violet: a two per cent. aqueous solution. Stain from two to four hours in the safranin and from two to eight minutes in the gentian violet. The slides should be taken through the alcohols quite rapidly, or too much of the stain will be washed out.

I have tried this on several kinds of starch, always with good results. Some slides with sections of the corms of *Erythronium*, which were stained over two years ago, are still of the same color and intensity as they were the day they were mounted. The stain is a clear purplish red and makes a good object for demonstration purposes. Paraffin sections of the young corms of *Erythronium* are especially favorable objects for showing the position of starch in cells, and by using the above method of staining the cells will look perfectly clear filled with the colored starch grains.

JOHN H. SCHAFFNER.

Botanical Laboratory, Ohio State University, Columbus, Ohio.

Journal of Applied Microscopy.

Issued Monthly from the Publication Department
of the Bausch & Lomb Optical Co.,
Rochester, N. Y.

L. B. ELLIOTT, EDITOR.

Address all communications to
PUBLICATION DEPARTMENT,
BAUSCH & LOMB OPTICAL CO.,
ROCHESTER, N. Y.

One Dollar per Year. To Foreign Countries, \$1.25
per Year.

Entered at the Post-office, Rochester, N. Y., as second-class matter.

OCTOBER, 1898.

EDITORIAL.

A large number of names for the Journal Microscopical Directory have been received, including representative biologists, petrographers and others who use the microscope, from nearly every quarter of the globe.

* * *

The Journal has had an agency in London since its second issue, notice of which appears on the front cover, and persons in Great Britain and Continental Europe desiring to subscribe, or receive sample copies, will find it more convenient to communicate with our London representatives. We have also completed arrangements with a reliable agency in the Hawaiian Islands. Interested persons in these islands or in Asia will find it more convenient to order from our Honolulu representatives as per address on front cover, back numbers and sample copies being kept on hand by them.

* * *

We have perfected extensive arrangements for securing reports from leading educational institutions for the department of News and Notes. We believe that this department will add much of general interest to the Journal, and extend an invitation to all institutions having biological laboratories to send us, regularly, news, notes, and queries for publication in this department. We should also like to be in communication with all the microscopical societies holding regular meetings, and to publish notices of such meetings in the Journal.

Current Botanical Literature.

CHARLES J. CHAMBERLAIN.

Books for review and separates of papers on botanical subjects should be sent to C. J. Chamberlain, University of Chicago, Chicago, Ill.

It is the purpose of the Department of Current Botanical Literature to present brief reviews of articles of special interest to those engaged in microscopical botany and also to give under the head of "Recent Literature" a list of of the more important books and articles in current periodicals. As a rule the "Recent Literature" will refer only to articles in current numbers, while the reviews may take note of papers further back. In referring to periodicals the abbreviations in common use will be employed. The number of the volume will be given in bold-face type, followed immediately by a colon; immediately following the colon will be given the pages occupied by the article and finally the date: e. g., *Bot. Gaz.* **26**: 239-246. 1898, means *Botanical Gazette*, Vol. XXVI, pp. 239-246, 1898. The method is brief, intelligible, and is becoming extensively adopted by botanists.

REVIEWS.

During the past two years plant spermatozoids have been studied as never before, and the result has been a series of papers of unusual merit. A brief resume is given below, the results of work on *Ginkgo*, *Cycas*, and *Zamia* being presented together.

Motile antherozoids have been discovered in *Cycas revoluta* by Ikeno, in *Ginkgo biloba* by Hirase, and in *Zamia integrifolia* by Webber. In the three genera the antherozoids are large ovoid bodies with numerous cilia at the anterior end.

1. *Bot. Centralbl.*, **69**: 1-3, 1897; also *Flora* **85**: 1, 1898.
2. *Bot. Centralbl.*, **69**: 1897; also *Journal of the College of Science* Vol. XII, Pt. II. June, 1898.
3. *Bot. Gaz.* **23** : 451-459, **24** : 16-22, and 225-235, 1897.

All three observers find a pair of spherical bodies in that cell which is to give rise to the two antherozoids. Ikeno and Hirase call these bodies attractive spheres, or centrosomes, but Webber does not believe that they are centrosomes and so calls them "centrosome-like bodies," and later proposes the term blepharoplast (cilia former) because they are found to give rise to the cilia. These genera resemble *Pinus* in the broadest outlines of the development of their pollen grain structures, the most striking divergence being that the two male cells develop cilia and become motile antherozoids. The presence of antherozoids, a Pteridophyte character and a pollen tube, a Spermatophyte character, would induce some botanists to regard such forms as "connecting links"

between the Pteridophytes and Spermatophytes. Engler has removed Ginkgo from the Conifers and placed it by itself in the Ginkgoales, a group co-ordinate with Cycads, Conifers, and Gnetums.

In the opinion of the reviewer the structures described by the various writers under the name of centrosome, centrosome-like body, or blepharoplast are not only homologous organs, but are genuine centrosomes as the term is understood by Zoologists. C. J. C.

Fujii, K. Has the Spermatozoid of Ginkgo a tail or not? Bot. Magazine (Tokyo, Japan) 12: 287-290, 1898.

This article, unfortunately written in Japanese, records observations upon the movements and structure of Ginkgo spermatozooids. While admitting that Hirase's figures show the appendage figured in his plates, the author is unwilling to regard the appendage as a genuine tail, but thinks it must be explained in some other way. Fujii failed to find such an appendage. C. J. C.

Shaw, Walter R. Ueber die Blepharoplasten bei Onoclea und Marsilia. Ber. d. deutsch. Bot. Ges. 16: 177-184, 1898.

In both Onoclea and Marsilia the eight secondary Spermatoocytes contain each a pair of blepharoplasts, and the sixteen spermatids which become transformed into the spermatozooids have each a single blepharoplast. In Marsilia two bodies resembling blepharoplasts were observed in each of the primary spermatoocytes. The author believes that the blepharoplasts, which give rise to the cilia of the antherozoids, are not to be identified with centrosomes. C. J. C.

Shaw, Walter R. The Fertilization of Onoclea, Ann. Bot. 12: 261-285, 1898.

The spermatozoid which consists of a corkscrew-shaped nucleus with a lateral band of cytoplasm, does not change in form or structure until after it enters the egg nucleus and even then its position can be distinguished for a long time. Throughout fertilization the egg nucleus is in the resting condition. The first division of the embryo takes place eight or ten days after fertilization.

This paper and the preceding work of Hirase, Ikeno, Webber, and particularly of Belajeff, who studied the spermatozooids of Ferns and Equisetum, have added immensely to the evidence accumulating against theories of heredity based upon the nucleus alone. C. J. C.

Schaffner, John H. Karyokinesis in the root tips of Allium cepa. Bot. Gaz. 26: 225-238, 1898.

Centrosomes are found in both resting and dividing cells. The achromatic spindle first appears as two flattened, dome-shaped prominences at opposite poles of the nucleus, apparently arising

from the two opposite centrospheres. The spindle becomes quite pointed before the disappearance of the nuclear membrane. Mottier, Osterhout, and others who deny the presence of centrosomes in higher plants have described an entirely different method of spindle formation. According to these writers, the spindle appears as cytoplasmic radiations about the nucleus; these radiations become grouped into multipolar spindles, which are gradually transformed into bipolar spindles. Schaffner thinks that multipolar spindles arise only through pathological conditions or imperfect technique. C. J. C.

Fulmer, Edward L. Cell division in Pine seedlings. Bot. Gaz. 26: 239-246, 1898.

The method of spindle formation is the same as that described above by Schaffner. No multipolar spindles were found. Root tips and cotyledons of germinating seeds were killed in Chrom-acetic acid and in Fleming's stronger solution. The safranin gentian violet-orange combination and Haidenhein's iron alum haematoxylin were the principal stains used.

It must be remembered that Schaffner and Fulmer have dealt with the vegetative cells while Strasburger's pupils of the Bonn Institute have based their conclusions upon karyokinesis in reproductive cells. C. J. C.

Ward, H. Marshall. Some Thames Bacteria. Ann. Bot. 12: 287-319, 1898.

To the general botanist the most interesting feature of this paper is the reference to the relationships of the Bacteria. He suggests that the endosporous bacilli may not have come from the Cyanophyceae, but from the Chorophyceae. The Chlamydobacteriaceae have probably had a different origin from the other Schizomycetes, the Schizosaccharomycetes suggest relation to the yeasts and the Myxobacteriaceae point to the Myxomycetes. "We should be prepared to accept that the morphological relationships of the minute organisms grouped together as Schizomycetes are neither few nor simple and that their phylogeny is probably not even comparable with a complex tree form, but is multiple in its origin." C. J. C.

RECENT LITERATURE.

(It is hoped to make such references much more numerous in the future.)

Hof, A. C. Histologische Studien an Vegetationspunkten. Bot. Centralb. 76: 65-69, 1898.

Juel, H. O. Die Kerntheilung in den Basidien und die Phylogenie der Basidiomyceten. Jahrb. f. wiss. bot. 32: 361-388, 1898.

Salter, J. H. Zur naheren Kenntniss der Starke Kornier. Jahrb. f. wiss. bot. 32: 117-166, 1898.

University of Chicago.

BOOK REVIEWS.

Practical Exercises in Comparative Physiology and Urine Analysis, by Pierre A. Fish, D.Sc., Assistant Professor of Comparative Physiology and Pharmacology, New York State Veterinary College, Cornell University. Published by the Author. 71 Pages. Manila Cover. 75c.

The purpose of this work is admirably stated in the preface. "This little manual has been designed, especially, to meet the needs of those students who desire to become physicians or teachers of science. * * * The majority of the experiments may be as easily performed in a preparatory school as in a college, with a little experience and ingenuity on the part of the instructor."

The work in physiology is qualitative throughout. About equal attention is given to the chemical side and to the physical side of the subject. The qualitative tests for many of the constituents of the organism and its secretions are given and the activities of the digestive juices are exemplified. In the physical part, the action of cilia, the circulation of the blood, the activities of muscle and nerve are treated.

In the part on urine analysis, it seems to the reviewer that a physician well acquainted with the experiments and tests here described would be admirably equipped for practical work. While here, as in physiology, the work is mainly qualitative, the empirical methods of quantitative estimation, so carefully worked out, are given and the centrifuge appears as a common laboratory appliance.

The work is modern, its directions are admirably concise and clear. It will aid teachers as well as students, and one can feel confident that, after acquiring the fundamental knowledge here given, he will be prepared to go on with the difficult qualitative tests necessary for the more complex and obscure elements of the body, and he will be ready to undertake and appreciate the quantitative work in the more advanced field of experimental physiology.

S. H. GAGE.

A Manual of Dissection and Histology for Use in Classes in Physiology, in High Schools, Normal Schools, and Academies. By G. H. French, A. M. Pub. J. B. Lippincott Com., Philadelphia.

Following its title the little book is divided into: Dissection, Part I; Histology, Part II.

After some preliminary remarks on methods of work, making of drawings and note taking, the author gives a brief laboratory account of the principal tissues and organs of a bird, a mammal, and a frog, with study of sections of some of

them, previously prepared by the student.

The presentation of the anatomy of the frog is simpler than that of the other two animals studied, and might precede them, as the author suggests, thus also following the order of increasing complexity. The organs studied are those usually discussed in elementary physiologies, except the skin, which is not more than mentioned for removal, while nothing is said of its histological study. Not much stress is laid on comparison of the organs studied in the three animals.

The introductory technique of Part II is given in sufficient detail to enable the intelligent student to make successful preparations; it includes a full description of the microscope and microtome. Then follow a set of fifteen "schemes for histology" in which the technique applying to special tissues is given. The usually good figures will be of much assistance to the student. Wherever the histology of any organ is given in Part I, these figures are referred to, thus making them serviceable for both parts of the book. There is a useful index at the back of the book, and in the front an explanation of terms too brief to be of much value.

The early and frequent use of technical terms seems to presume, that which the student is to learn, some knowledge of anatomy. Thus, under "dissection of a bird—bones," the student is directed to "find the humerus, ulna, and radius;" and farther on, under "small intestine," he is asked, "Are there any Payer's glands?" this enigma (to the young student) being somewhat elucidated fourteen pages farther on, after the same question, by the statement, "for place and shape of these see Fig. 20, Part II."

Occasional loose statements will mislead the student: thus, under dissection of the bird's brain, he is directed to "notice fibers connecting the brain with the skull. These are the cranial nerves." In Part II, under "Structure of Cells and Mitosis" (this, by the way, is introduced between two wholly foreign subjects—"submaxillary gland" and "muscles"), we read, "Ordinarily cells are composed of two coats and fluid contents within;" and speaking of indirect cell division, the author says "the study of this is called mitosis." Under this head would also come "nucleated blood, non-nucleated blood."

Much valuable time is lost by the student's being directed to "find" the merely named parts, and the technical name at that. Every teacher of younger students knows how much easier it is to tell the student to find organs than to tell him how and where to find them, but that it is best of all, though more diffi-

cult, to ask questions leading him to find them for himself. But even with the best book in hand, the teacher is indispensable to the student, and in the hands of any live teacher this little book will prove useful in many schools.

While scarcely suitable for high school work, there is much to recommend the manual for use in normal schools, and for more advanced students, where training may be less the object than is the accumulation of information; and as a pioneer in its line we heartily wish it success.

L. MURBACH.

Detroit, Mich., September, 1898.

Micro-organisms and Sterilizing Processes in the Canning Industries. Souring of Canned Sweet Corn. S. C. Prescott and W. Lyman Underwood. Technology Quarterly Vol. XI, No. 1, 1898.

The canning industry, like many other technical processes, has grown up in a purely empirical way. The methods that are used are the results of pure experience. Too frequently, scientific methods are not considered, and as a result considerable losses are occasioned that might readily be prevented if modern methods based on scientific research were instituted. The present paper takes up a phase of an important industry. Its successful operation depends upon the fulfillment of biological laws. After describing the history of the growth of this industry, the authors take up the question of the souring of corn, and show that this defect is always associated with bacterial action and imperfect sterilization. They isolated a number of different species from spoiled corn, and they also showed that these same forms were to be found on the kernels and beneath the husks as it comes from the field. The failure of the corn to keep comes from insufficient sterilization. When the filled can is heated up even in a steam apparatus under pressure, the temperature of the interior of the can does not equal that of the outside unless the exposure is prolonged. Thus, in sterilizing the cans for an hour, the interior is subjected to the proper sterilizing temperature for only five minutes. This exposure is too short. A temperature of 250 degrees F. for ten minutes is sufficient to produce perfect sterilization. The use of the intermittent method of sterilizing or an open water bath was found to be impractical. The losses which are occasioned annually from these unscientific methods show the necessity of a dissemination of knowledge pertaining to the biology of these problems.

H. L. RUSSELL.

University of Wisconsin.

NEWS AND NOTES.

Minor notes on technique, personals, news items, notices of meetings of societies, conventions, etc., will be received up to the twenty-second of the month preceding issue.

"Two thousand Red Corpuscles of Human Blood measured by F. J. Parker in the Pathological Laboratory of the Medical Department of Yale University, under the supervision of Prof. M. C. White, M. D."*

Each specimen of blood was spread upon a slide and quickly dried and covered with thin glass. Measurements were made by a Zentmayer filar micrometer rated by a Zeiss stage micrometer divided to one-hundredths of a millimeter.

First, 500 corpuscles were measured from an American girl seventeen years old. The average diameter of the 500 measured was 7.90 mikrons; largest corpuscles, 9.11 mikrons; smallest corpuscle, 6.72 mikrons.

Second, 500 corpuscles from an Italian boy, 17 years old, who had been in America three months. Average diameter of the 500 measured was 7.99 mikrons; largest corpuscles 9.25 mikrons; smallest corpuscle 6.78 mikrons.

Third, 500 corpuscles from a girl from Finland, 25 years old, who had been in the United States five months. Average diameter of 500 corpuscles measured 7.89 mikrons; largest, 9.80 mikrons; smallest, 6.65 mikrons.

Fourth, 500 corpuscles from Miss Awchee, an Esquimax girl, who had been in New York about four months, age about 12 years. Average diameter of 500 corpuscles measured 8.07 mikrons; largest corpuscle, 9.52 mikrons; smallest, 6.65 mikrons.

In all cases the measurements were taken to include all of the dark border of the corpuscle, the corpuscle being pinched between the two spider lines of the micrometer.

These measurements do not favor the statements of Gram as quoted by Cabot in his book on the blood, that the inhabitants of Northern Europe have a larger average diameter of red blood corpuscles than those of Italians and Germans.

M. C. W.

*After concluding his measurements, Dr. Parker entered the Naval service of the United States, before he had time to write this report in detail.

Prof. T. W. Edgeworth David, B. A., F. G. S., of Sidney University, New South Wales, has recently made some very important and interesting discoveries of radiolaria in early Palaeozoic rocks in New South Wales. In the New England district they are found in red

jaspers, possibly of middle Devonian age, at Bingera and Barraba. At Tamworth there is a radiolaria series at least 2,000 feet thick. The radiolaria are abundantly distributed through claystones and cherts in the form of chalcedonic casts. These are associated with limestones containing *Stromatopora*, *Favosites*, *gothlandica*, *Pachypora*, and *Heliolites*. At Jenolan caves, overlying the cave limestone, are clay shales and cherts containing radiolaria. The Cave limestone contains *Stromatopora*, and *Pentamerus knightii*.

The radiolaria are best preserved and most abundant in the cherts, towards the formation of which they must have contributed largely. Under the microscope they appear as spherical or oval bodies up to two millimeter in diameter. Traces of the latticed structure are not infrequently shown. The best preserved specimens occur in thin bands of siliceous limestones, and are well shown by etching a slice with weak acid. While the original siliceous skeleton is generally preserved, it is sometimes replaced by pyrites. Often internal casts in chalcedony alone remain. The forms present fall for the most part in the group *Spumellaria*. G. W. C.

Sydney, New South Wales.

The University of Pennsylvania is gradually bringing the equipment of her Biological department up to the latest and best standards. The zoological side is to have a "live house," now in process of erection, which will afford unusual facilities in the study of habits, habitats, breeding seasons, etc. It is the purpose of Professor Conklin to stock the vivarium with representatives of all the groups of animals, from monad to monkey. There can be no doubt that a long felt want will be filled, and the University is to be congratulated on being not only the first in the country, but the first in the world, to make such provision for zoological investigation.

J. R. M.

The department of Biology, University of Missouri, will be conducted by the following corps of teachers: Howard Ayers, S. B., Ph. D., professor of Biology; Chas. Thorn, A. B., A. M., instructor in Botany; Clarence M. Jackson, B. S., teaching fellow in Zoology. Instruction is given this semester in the following subjects: General Biology of Animals and Plants, Human Histology, Mammalian Embryology, Comparative Anatomy of Vertebrates, Vertebrate Zoology, Research in Morphology of Fishes, Plant Physiology, Research in the Grasses of the United States. H. A.

Recent appointments in the department of botany of the University of Nebraska are as follows: Frederic E. Clements, Ph. D., to be instructor in Botany (advanced from assistant); Edna L. Hyatt, Botanical Artist (reappointed); Cora F. Smith, B.Sc. to be Fellow in Botany; Albert F. Bill, B. Sc., to be Fellow in Botany.

The summer session of the University of Nebraska for this year was six weeks long. In the botanical laboratory one semester's work in general botany was offered, and by fully three-fourths of the class satisfactorily completed. The work included a daily lecture, about one hundred having laboratory work. As the class was made up entirely of teachers in the graded and high schools, the importance of this work to the schools of Nebraska can scarcely be over-estimated.

The Biological department of the University of California is to be conducted during the coming year by the following professors and assistants: Natural History and Geology, Prof. Jos. LeConte, Wm. E. Ritter, associate; Zoology, Prof. H. P. Johnson, H. P. Tory, instructor.

The new laboratories for Plant Physiology at the University of Chicago will be opened October 1st, under the direction of Prof. Chas. R. Barnes. They will occupy the fourth floor (50x102) of the Hull Botanical Laboratory, which has been especially fitted up for this purpose. A sufficient amount of supplies and apparatus will be provided in the course of the year for the regular courses, and apparatus for research will be constructed or purchased as needed in the future. About a dozen graduate students have already indicated their intention of registering for the new course. The laboratories are supplemented by a roof greenhouse about 30 by 60 feet. A competent gardener will be in charge.

Mr. W. A. Riley, who has been assistant in the department of Biology of DePauw University for the past three years, will spend the coming year in study in the department of Invertebrate Zoology, Cornell University. Mr. H. H. Zimmermann will take Mr. Riley's place in DePauw laboratory.

The following is a brief outline of the more important courses offered in the Geological Department of Johns Hopkins University, this year, in which work with the microscope forms an essential feature:

1. Paleontology, by Dr. W. B. Clark,

lectures twice weekly; laboratory opened daily. In this course attention is devoted to both the biological and geological relations of the important types of animal and plant kingdoms. The phylogenetic history of the leading groups is also traced out in considerable detail wherever possible. Specimens and diagrams are largely employed to illustrate the lectures. Typical material is selected for the laboratory work. This includes the use of the microscope in the work on foraminifera, radiolarians, diatoms, certain corals, sponges and other of the more minute forms of life.

2. Advanced mineralogy, by Dr. E. B. Matthews, lectures three times weekly. Laboratory work. The lectures will include a full discussion of optical and microscopical mineralogy. Especial attention will be given to the behavior of minerals as constituents of rock masses.

3. Petrography, by Dr. E. B. Matthews. Lectures three times weekly; laboratory open daily. The course will include a discussion of methods and a description of the structure and physical properties of rocks. The second portion of the course is devoted to the special petrography of the igneous rocks, including a study of their various classifications and a discussion of their origin, distribution and literature. The consideration of the more common sedimentary and metamorphic rocks concludes the course. The constant use of the petrographical microscope forms an essential part of the laboratory work. The department is well equipped with thin sections of minerals and rocks from the best known and most thoroughly studied localities in both Europe and America, embraced in the Williams, Lewis, Sturtz, Lehman, and numerous smaller collections. L. C. G.

The new Science Hall of Syracuse University is nearing completion and will be ready for occupancy early in the fall.

The biological department will have quarters in the new hall, occupying the entire second floor. Additional facilities will be provided and the courses of the department extended correspondingly.

Mr. M. Smallwood, instructor in Biology, has recently been elected to the department of Biology and Geology, Allegheny College, and has gone to his new position. Dr. A. A. Tyler, from Columbia University, has been made instructor in Botany, and will enter upon his duties at once.

Professor Charles W. Hargitt, after nearly three months at the Laboratory of the United States Fish Commission, and the Marine Biological Laboratory, Wood's Holl, has returned and reports a most successful season.

An easy and efficient method of preparing nucleated blood for class use has been adopted in the Histological laboratory at Cornell this year. A few drops of the fresh blood of a neoturus are put in a solution of osmic acid (one per cent.) and allowed to stand for about fifteen minutes. The corpuscles by this time are fixed and have settled to the bottom, and the fixer can now be decanted off. After washing in water the blood is carried on through the various grades of alcohol, stained with paracarmine, dehydrated, cleared, and as a final step Canada balsam is added sufficient to procure the proper dilution of the corpuscles. It now only remains to put a drop of the balsam on a slide, and cover with a cover glass. A neat preparation is now ready for use. The bottle of balsam containing the stained corpuscles can be kept an indefinite length of time and is always ready for use. The stain obtained is differential and striking. The nucleus is colored a rich brown and the hemoglobin a bright amber red. The great advantage this method has over the glycerine-jelly mounts used heretofore, is that inexperienced students are sure to, now and then, let the objective down upon the cover. With the glycerine-jelly mounts the position of the corpuscles is thus disturbed. As the blood corpuscles are used to give the student an introduction to micrometry, this instability of position becomes a grave difficulty. With the hardened balsam mounts it is impossible to disturb the position of the corpuscles without using sufficient force to destroy the whole preparation.

During a part of four weeks of this summer, about four thousand slides have been prepared for class work for the ensuing year. The work of preparing was done by two students at a cost, for labor, of between three and four cents per slide. The staining device described in an article appearing in the last issue of the Journal was used in this work to great advantage.

Prof. Vernan F. Marsters, of the Geological department of the University of Indiana, offers two new courses this year; an elementary course in physiology, and a more advanced course on the physiography of the United States.

Assistant Professor John F. Newson is on leave of absence for one year. Edgar R. Cummings is instructor in Paleontology.

The course in Petrography is taught in the Michigan College of Mines in the senior year, and requires the preparatory courses Physics, Chemistry, Geology, Crystallography, and Mineralogy, which must be completed before the

student is allowed to enter upon his course in Petrography.

There are twenty-one students taking this laboratory course this year. The course calls for twelve hours a week during the fall and winter terms. The subject is taught from Rosenbusch's "Microscopical Physiography of Rock-making Minerals"—translated by J. P. Iddings, and from Dr. M. E. Wadsworth's manuscript notes.

"Tableaux des Birefringences," by Levy and Lacroix, are used in laboratory work. The college is equipped with twenty-nine Bausch & Lomb microscopes fitted up especially for the college, so that each student is provided with a microscope. The college now has over eight thousand thin sections of minerals and rocks, made expressly for this department from cabinet specimens in the college collections.

The student is first given a thorough drill in the optical characters of minerals and the use of the microscope in their determination.

He is then required to do a large amount of laboratory work in studying the hand specimens along with the thin sections, made from chips taken from the hand specimens. After a sufficient number of known specimens have thus been examined, the student is given a large number of unlabeled specimens of these rocks, upon which he recites. Special attention is directed towards training the student, so that he can readily determine the ordinary rocks with facility, with the use of a good lens, thus making it as practical as possible for the Mining Engineer. F. H. S.

The Botanical department of Ohio State University has been making slow but substantial progress for a number of years. The department has its own building, which, although sufficient for present purposes, will soon be too small to accommodate the increasing classes and equipment. On the first floor there is a large lecture room and a special laboratory for systematic botany; also the office of the head professor, a store room, dark room, library, and florist's office. On the second floor is the main laboratory, which will accommodate a section of twenty students; also a special laboratory for advanced students in morphology, the assistant's office, and a large room which is used for the botanical museum and all of the herbarium except the Ohio State Herbarium, which is on the first floor. Connected with the building is a large greenhouse which is of much service in supplying material for class use and for illustrative purposes.

The laboratories are furnished with a

large number of dissecting microscopes, twenty compound microscopes for students in general classes, and five compound microscopes for the use of professors and advanced students. There are also sterilizers, paraffin ovens, incubators, and microtomes; sufficient though not extensive apparatus for carrying on advanced work in cytology and embryology, and enough for the elementary physiology.

The apparatus added this year will aid materially in carrying on the department work. The more important pieces are the following: One Bausch & Lomb photo-micrographic camera; one Leitz microscope with compensating oculars and 1-16 oil immersion objective; one Premo senior hand camera; one Bausch & Lomb incubator. J. H. S.

Mr. Victor H. Bassett, late fellow in chemistry in the University of Wisconsin, has been appointed to the position of assistant bacteriologist in the Agricultural Experiment Station connected with the university.

Will readers of the Journal kindly make the following corrections in the article on page 149, of a typographical error which occurred by reason of the writer's absence at the time the proofs could have been corrected:

Line 26, change "microscopic" to "Micrographic."

This misprint is so bad as to be almost good—as a dreadful example of "how not to do it," since it stultifies the article by using one of the words in question in exactly the sense which it was the object of the article to protest against. Of course "the Micrographic dictionary" was specified on account of its being familiar to all microscopists as a large, thick, clumsy volume. "A microscopical dictionary" might have been mentioned instead, but was not, as it would be a vague, weak, and even equivocal allusion; while "the microscopic dictionary," as given by the printer, is not only inapplicable where it stands, but is also, by an odd coincidence, perfectly applicable to the "tiny book" mentioned in contrast below, which also happens to be a dictionary, and microscopic but not microscopical.

It may be added that, when referring to parts of the instrument or of its outfit, neither of these words seems to serve as well, or at least to sound as well, as the corresponding noun used in an adjective sense; as in speaking of a microscope lens, a microscope object or slide, etc. R. H. W.

Troy, N. Y.

Journal of Applied Microscopy.

VOLUME I.

NOVEMBER, 1898.

NUMBER 11

Formalin as a Reagent for Blood Studies.

There is always great difficulty in preparing in bulk, for laboratory purposes, those tissues or parts of tissues which are liquid by nature, such as blood and lymph. It is very easy to prepare pieces of muscle, liver, or other solid parts, for detailed microscopical examinations of histological constituents, when they can be hardened and infiltrated. But blood corpuscles can not easily be thus treated. There are usually several difficulties connected with such a process, as separating the corpuscles from the plasma, mounting the separated corpuscles without distortions, and making them take the stain.

It has been found that almost all reagents cause some changes in the general shape and outline of corpuscles. Osmic acid is claimed to harden and preserve them without distortion, but as this substance is quite expensive and difficult to operate, it is not adapted to general laboratory use among young, inexperienced students. The method of drying fresh blood upon the cover-glass is not usually successful, for the corpuscles are generally distorted by drying, or else they refuse to take the ordinary stains after being dried.

For general laboratory use formalin is an excellent preservative and fixing agent. It is less expensive and more easily operated than osmic acid. It causes no appreciable distortion of the cells and does not interfere with staining. The method used is as follows:

1. A quantity of freshly drawn blood, before coagulation has taken place, is mixed with at least three times its volume of a two per cent. formalin solution.

2. After allowing the mixture to stand at least one hour, a drop from the bottom of the vessel is placed upon a cover-slip

and a second cover-slip is pressed lightly upon it; then the two are separated and the liquid is allowed to evaporate.

3. The dried cover-slips are then passed quickly through the flame in order to fix the corpuscles more securely to the glass, so that they may not be removed by subsequent treatment.

4. When cool, dip once or twice into a five per cent. solution of acetic acid.

5. After removing the acetic acid with water, stain. If the corpuscles are nucleated, it is best to use some contrast stain, as haematoxylin and eosine or methyl green with eosine or saffranin. If an alcoholic stain is to be used, the films must be washed with alcohol before staining. Non-nucleated cells do not require a contrast stain. Human corpuscles may be stained with Ehrlich's triple stain.

6. Remove excess of stain with water or alcohol as stain requires.

7. Remove alcohol with xylol, clove oil, or turpentine.

8. Mount in Canada balsam.

This method was employed successfully in the laboratory at Purdue University in all blood studies. The bloods used in these studies were those of the cat, the chicken, the ox, the pigeon, and man. The human corpuscles examined seemed to resist all stains for some reason, until the films were treated with a dilute solution of acetic acid. The acid seemed to possess a double function; first, that of clearing the films, and, second, that of causing the stain to become effective.

This method may be of no particular clinical value, but for general laboratory purposes it promises to be a success.

ERNEST I. KIZER.

Biological Laboratories, Purdue University.

Laboratory Methods in Bacteriology.

DR. F. G. NOVY.

III.—Gram's Method.

With the exception of the tubercle bacillus, the methods of staining heretofore described are simple in character. That is to say, the germ and background are stained alike. In the case of the tubercle bacillus, special double-staining was resorted to, because this reaction is so characteristic as to enable immediate recognition of the organism. Only two or three other organisms are known which will double stain when treated by the same method.

There is, however, a method of double staining which is applicable to a large number of bacteria. This process, known as Gram's method, is based upon the fact that the protoplasm of certain bacteria forms a difficultly soluble compound, when stained with anilin-water gentian violet and subsequently treated with iodine. On treatment with alcohol the dye is washed out of everything on the specimen except out of the germs. The deeply stained violet bacteria lie now on a colorless background which, on staining with a contrast color, such as eosin, becomes stained a light pink. The method is as follows:

A solution of anilin-water gentian violet is first prepared. Anilin oil is placed in a test tube to a depth of about half an inch. The tube is then filled with water, closed with the thumb, and thoroughly shaken in order to obtain a saturated aqueous solution of anilin. The liquid is then passed through a small filter, and collected in another test tube. The filtrate should be perfectly clear, not cloudy. To the anilin water thus obtained a saturated alcoholic solution of gentian violet is added till the fluid is deeply colored, rendered opaque. This result is obtained when about one-half cubic centimeter of the gentian violet solution is added to ten cubic centimeters of the anilin water.

Some of the anilin water gentian violet thus prepared is poured out into a watch glass. The cover-glass preparation is prepared in the usual way, dried in the air and then fixed by passing through a flame. The fixed cover-glass is placed between the thumb and forefinger, with the specimen side down, and then carefully dropped upon the surface of the stain. It is allowed to float on the dye for three to five minutes.

The cover-glass is then picked up with the forceps, thoroughly washed with water, and immersed in a solution of iodine in potassium iodide. This is made by dissolving two grams of potassium

iodide, and one gram of iodine in 300 cubic centimeters of distilled water. The specimen is allowed to remain in the iodine solution for three to five minutes. It is then removed, washed with water, and placed in 95 per cent. or in absolute alcohol. If the specimen has not been overstained, decoloration will take place rapidly. This may be assisted by gently tilting the dish, or by moving the specimen.

From time to time the cover-glass should be washed with water, placed on a slide, and examined with a one-sixth inch objective to ascertain the progress in decoloration. If the material has been spread out in a thin, even layer the decoloration will be rapid and thorough. On the other hand, if thick masses are present it will not be possible to obtain complete decoloration, without decoloring at the same time many of the bacteria. When, therefore, the greater part of the background has been decolorated the treatment with alcohol should be discontinued.

The cover-glass is then washed with water, and stained with dilute eosin for one-fourth to one-half minute. Care must be taken not to overstain the preparation with eosin, since this would diminish the sharp contrast desired. After staining with eosin the specimen is thoroughly washed with water, and examined under the microscope. It should show the deeply stained violet bacteria on a light pink background.

Gram's method is applicable to many non-pathogenic and pathogenic bacilli and micrococci. A number of important disease bacteria are not stained by this method. Among these may be mentioned the gonococcus, the germs of typhoid fever, Asiatic cholera, influenza, black plague, glanders, and chicken cholera.

The method is applicable for staining the micrococci present in pus, the germs of erysipelas, diphtheria, tuberculosis, leprosy, actinomycosis, anthrax, etc. It is especially valuable when endeavoring to detect these organisms in material rich in organic matter, such as blood and pus. Most excellent results are obtained when the method is applied to sections of tissue.

The beginner can familiarize himself with the method by applying it to the staining of tubercle bacilli in sputum. It can also be tried for the detection of the diplococcus of pneumonia in the "rusty" sputum of that disease.

The method described may be summarized as follows:

Anilin-water gentian violet (three to five minutes),

Water,

Iodine in potassium iodide (three to five minutes),

Water,
 Strong alcohol,
 Water and examine,
 Contrast color, eosin (ten to twenty seconds),
 Water and examine,
 Dry in air,
 Canada balsam.

DOUBLE STAINING OF SPORES.

Many bacilli when grown under favorable conditions form spores. These bodies, which are the analogues of the seeds, in the higher plants, are formed within the bacterial cells. As a rule but one spore is formed within one bacillus. When the spore-containing bacillus is stained by dilute fuchsin or gentian violet, the bacterial cell proper will take the stain, whereas the spore will remain colorless. This resistance to coloration on the part of the spore is due to the dense impenetrable wall which envelopes the contents of the spore. Under certain conditions the staining reagent can be forced into the spore. Once inside, it becomes as difficult to remove the dye as it was to introduce it. On careful treatment with alcohol the stain can be washed out of the bacterial cell proper so that if the specimen is examined the spore will appear deeply stained within a colorless bacillus. On treatment with a suitable contrast color, the latter becomes colored and shows the spore in marked relief.

Spores containing bacilli may be found on potato cultures, prepared as described in the first paper. They may be present after the growth has developed for several days. If available, sporulating hay bacilli may be used.

Cover-glass preparations are prepared and fixed in the usual manner. The preparation is held in the forceps in the left hand with the specimen side up, and covered with fresh carbolic fuchsin solution, or anilin water fuchsin. It is then held over a low Bunsen flame so that vapors are slowly given off. From time to time the liquid lost by evaporation is replaced by the addition of a drop or two of the dye. Under no condition should the dye be allowed to dry down on the cover-glass.

After heating the specimen in this manner for two or three minutes, it should be thoroughly washed in water and examined under the one-sixth or one-eighth inch objective. Colorless spores should no longer be visible, but everything should be stained a deep red. If the spores are not colored, the specimen should again be covered with carbolic fuchsin and heated till they take on the stain.

The cover-glass with the deeply stained spores is then placed in dilute alcohol and gently moved about. From time to time, it should be washed in water and examined under the microscope. As soon as the bacilli are decolorized, the washing in alcohol is discontinued. The specimen then shows bright red spores within cells that are almost or wholly colorless. The cover-glass is then stained for a short time with methylene blue, washed with water and examined. The spores should be stained a deep red while the bacillus itself should be light blue.

The method of double staining spores, it will be noticed, is essentially the same as that employed for staining the tubercle bacillus. The method may be summarized as follows:

Cover-glass preparation,
 Dry in air,
 Fix in flame,
 Carbolic fuchsin (hot, two to five minutes),
 Water, and examine,
 Dilute alcohol,
 Water, and examine,
 Contrast color, methylene blue (one-quarter to one-half minute),
 Water, and examine,
 Dry in air,
 Canada balsam.

STAINING OF FLAGELLA.

Many bacteria possess active motion. The organs which cause this movement cannot be seen when the germs are examined in hanging-drop. Moreover, they are not rendered visible by the ordinary methods of staining. In order to demonstrate their presence, it is necessary to resort to a special procedure. The organism will then be seen to be surrounded by a fringe of very delicate wavy lines known as whips or flagella. The number of flagella will vary with the different species of bacteria, but usually a bacillus will possess from three to ten or more of these delicate appendages.

The method of staining flagella is, with slight modifications, that proposed by Löffler. Special attention must be given in the first place to the preparation of the specimen. Only fresh, vigorous, active cultures should be employed. The growth, therefore, should not be more than one or two days old. In old material the whips are liable to be torn off from the cell.

An excess of material should not be placed on a cover-glass. It is advisable to first prepare a suitable dilution of the germs. For this purpose two or three drops of distilled water are placed on a slide and a very small amount of the

growth is transferred to the water. The latter should be rendered just barely cloudy by the bacteria thus introduced. By means of a very small loop some of this suspension is taken up, transferred to a clean cover-glass, and spread out as evenly as possible.

The specimen is allowed to dry in the air or by gently waving it over a flame. The next step is to fix the material. This should not be done in the ordinary way inasmuch as there is danger of overheating, which would destroy the delicate whips. The cover-glass should be held between the thumb and forefinger, specimen side up, and quickly passed through a flame once or twice. There is thus no risk of over-heating.

The staining process requires the use of two solutions. The first one employed serves as a mordant, and, as used by Fischer, is prepared as follows: Two grams of dry tannin are dissolved in twenty cubic centimeters of water, and to this liquid four cubic centimeters of a ferrous sulphate solution (1:2), and one cubic centimeter of a concentrated alcoholic solution of fuchsin are added. The mixture is thoroughly stirred and the resultant precipitate is removed by filtration. The filtered mordant will keep for some time, and is said, indeed, to improve with age.

The stain proper is a hot saturated aqueous solution of fuchsin (1:50). An anilin-water fuchsin may be used to advantage.

This is prepared by adding two to three grams of fuchsin to 100 cubic centimeters of anilin water and heating till solution results.

The fixed specimen is held in a pair of forceps and the surface moistened with a drop of water. It is then covered with the mordant and gently heated over a low Bunsen flame so that vapors are slowly given off. At no time should the liquid boil. After heating thus for one to two minutes the cover-glass is washed thoroughly under the tap. If the specimen has not been overheated, every trace of the mordant will wash off and leave a perfectly clear, colorless cover-glass. If a ring of deposit forms on the edge of the glass, and even this can be prevented by careful heating, it must be removed by scraping with the blade of the forceps.

The clean, mordanted cover-glass, moistened if necessary with a droplet of water, is then covered with the fuchsin stain, and slowly and gently heated over a flame, for one to two minutes. Actual boiling of the liquid should be avoided. The specimen is then washed thoroughly and examined.

On examination with a one-eighth inch, or, better, with a one-twelfth inch homo-

geneous oil immersion objective, the bacilli will be seen to be provided with a number of very fine, wavy lines, the flagella. If much granular matter has been deposited on the cover-glass, it is as a rule due to overheating while mordanting, or while staining. Not a little patience and intelligent manipulation is necessary in order to obtain stained flagella on a clear, colorless background.

The method of staining flagella can be summarized as follows:

Dilution,

Cover-glass preparation,

Dry in air,

Fix in flame by touching once,

Mordant, hot (one minute),

Water,

Concentrated aqueous or anilin-water fuchsin, hot (one minute),

Water, and examine,

Dry in air,

Canada balsam.

University of Michigan.

(To be continued.)

Low Temperatures for Physiological Experimentation.

The use of cold as a factor is rapidly extending to several phases of physiological experimentation. Ordinarily, lower temperatures are obtained by freezing mixtures. Salt and ice will give, if properly manipulated, a temperature of -13°C , and calcium chloride with snow will give -42°C . In northern latitudes, however, advantage may often be taken of outside cold, but this has its disadvantages since it is not always agreeable or even convenient to carry on experiments in winter weather.

In work of this character, in the laboratory for plant physiology of the University of Minnesota, the following methods are used:

In the use of freezing mixtures, such as that of ice and salt, the mixture is placed in one vessel several feet above the floor and the fluid allowed to flow through the jacket of an ordinary chemical condenser to a lower vessel, from which it is returned to the first by means of a hand pump or by pouring. The material to be frozen is placed in the condensing tube, either free or in small phials, and through the upper stopper a thermometer is inserted.

It is possible to reduce the temperature of ten cubic centimeters of material from 10°C to -18°C in a few minutes by this method, but it is necessary that the ice be very finely

broken and very evenly mixed with salt if the best results are to be obtained.

If more rapid or practically instantaneous freezing is desired, the material is placed in a suitable receiver and subjected to the action of escaping liquid carbon dioxide, a process which will give much lower temperatures than any of the above methods. With the cheapening of liquified air it also may be utilized as an agent in such methods, and protracted exposures to low temperatures would then be possible.

Long exposure of material to fairly low temperatures may be obtained in the rooms of a cold storage establishment where convenient space can be rented at a low rate for indefinite periods.

H. B. HUMPHREY.

Physiological Laboratory, University of Minnesota.

Cultivation of Algae in Aquaria.

Some points relative to the cultivation of Algae in aquaria may be helpful to amateur workers in this line. It is the usual practice to collect Algae like *Vaucheria*, *Spirogyra*, etc., and put them in a large glass vessel from one-half to two-thirds filled with water, in the hope that they will grow and fruit and thus furnish a supply of material for future use. Very often, however, the plants soon turn yellow, decay, and rise to the surface, where they form a foul-smelling scum. Usually the next step is to empty the aquarium. This should not be done, however, as after a time the material settles to the bottom, new growth starts; and if any spores of the desired Algae are present they will grow along with others and no further trouble will be experienced. But it is better not to risk the loss of material by allowing it to go through the fermentation process. In order to avoid fermentation the water must be kept thoroughly supplied with oxygen. This can sometimes be done by placing the Algae in a broad vessel with shallow water, and occasionally aerating by dipping up some of the water and pouring it back, allowing it to strike the hand held just above the surface of the water in the vessel, so as to break the force of the descending stream, and in this way prevent the disturbance of the colonies of Algae and the stirring up of sediment.

A better way, however, is to grow in the water some good aerating plants, like *Myriophyllum*, *Cabomba*, *Ranunculus*, water mosses, etc.—in fact any submerged aquatic plants which give off bubbles of air (largely oxygen) when exposed to light. Algae introduced in small quantities into aquaria thus sup-

plied with oxygenating plants will thrive for long periods quite as well, if not better than in their original habitat. It is also well to introduce if possible some little fresh-water Crustaceans; Cypris or Cypridopsis are especially good. They are the most harmless of scavengers, living mainly on decaying vegetable tissue, especially the soft tissue, or parenchyma. They are particularly fond of the mesophyll of leaves, which they remove, leaving beautiful leaf skeletons.

ALBERT F. WOODS.

Division of Vegetable Physiology and Pathology, U. S. Department of Agriculture.

A Thermostat for High or Varying Gas Pressure.

To those who use natural gas as fuel in their laboratories, the following easily constructed thermostat may be of interest. With the high pressure and the great variation of the ordinary service, the usual mercury regulators cannot be used without the intervention of some more or less expensive reducer. The apparatus is described, not as presenting anything new in principle, but as something which anyone with a little skill can construct and which will perfectly control any pressure of gas and maintain the temperature of the oven, bath, or incubator with a variation of less than one degree.

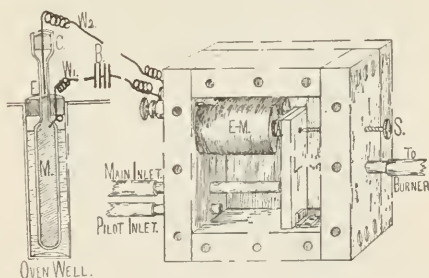

A glass tube or bulb with a slender neck is placed in a well of the oven and filled with mercury, M. A wire, W_1 , from one pole of a battery, B, is blown into its side so as to make contact with the mercury. Through a cork, C, in the top of the tube another wire, W_2 , is passed into the narrow neck and may be raised or lowered at will. This wire passes to the binding post of the regulator, through the coils of the electro-magnet and to the other pole of the battery.

The regulator consists of a small, carefully fitted wooden box fastened with glue and screws. The cut represents it

with the front removed. It contains an electro-magnet, E-M, placed in the circuit as described above. The armature, A, is attached to the upper end of a lever L, fastened to the bottom of the box by a hinge and free to move through a small arc whose length is varied by the adjusting screw, S. On the same side as the armature, but lower down so as to afford a good leverage, is a small rubber cushion which shuts against and closes the main inlet tube when the armature is drawn to the magnet. A smaller pilot inlet regulated by the gas cock affords gas sufficient to maintain a pilot flame when the main inlet is closed. These inlets and exit are short metal tubes and are connected with the gas supply and with the burner by means of rubber tubing. While the circuit is open the gas enters at the main and pilot inlets and passes out at the opposite side of the box to the burner. When the circuit is closed by the mercury rising in the bulb till it touches the electrode at E, the main inlet is shut off and the pilot inlet admits gas sufficient only to preserve the flame till the oven cools and the circuit is interrupted by the fall of the mercury. The temperature at which the circuit is made and broken may be regulated by raising or lowering the wire in the neck of the tube. The coils of the electro-magnet are wound with No. 32 copper wire and have a resistance of one ohm each. Two Edison-Leland cells are sufficient to operate the regulator.

This is an improvement upon the old arrangement where the gas was confined to an outer and an inner tube, with a magnet working on a membrane over the ends of the tubes, because the expansion of the gas in the box prevents the too sudden lowering of the supply at the flame, which occurred under the old plan, and also because there is no membrane to get stiff or crack.

DONALDSON BODINE.

Wabash College.

Projection Microscope—A New Departure.

At the annual meeting of the American Microscopical Society, Prof. M. C. White, M. D., of Yale University, exhibited an electric lantern microscope with a 20 mm. objective with an estimated aperture of 0.95 n.a., manufactured on his order on the following principle:

Taking as a model the 5 mm. apochromatic objective of Bausch & Lomb catalogue, made on the formula of Prof. Hastings, Prof. White directed Bausch & Lomb to make an objective which should have the diameter of every lens and the radius of every curvature four

times as great as that of the 5 mm. apochromatic objective. Prof. White desired to try such a mammoth objective in the projection microscope.

The objective thus made is shown of natural size in Fig. 1, and is seen compared with aa. achromatic of Zeiss 0.30 n.a., of the same powers as the large objective, and on the other side is shown the 12 mm. 0.65 n.a. apochromatic made by Zeiss.

In Fig. 2 is shown, half natural size, the new objective in the carrier made as for a lantern objective. Beside it is also shown a No. 1 projection eyepiece made for use in the microscope with this new objective. This new projection microscope, hastily put together in temporary mountings, not yet perfected and only partly tested, was shown by Dr. White, showing blood corpuscles well defined on the screen.

A vote of thanks was tendered to Dr. White by the society for exhibiting this new and expensive apparatus, which bids fair to greatly increase the usefulness of the projection microscope.

Dr. White's theory is that if, in using the ordinary microscope, a certain angular aperture is required to secure proper definition with a magnifying power of 1,000 diameters, then a similar aperture will be necessary to secure good definition in an image projected on the screen, even if it is obtained with a three-fourths-inch objective and a projection eyepiece.

Fig. 4 shows this new projection microscope as mounted for use. It is supplied with J. B. Colt's Criterion lantern electric light, with rheostat taking incandescent current of 110 volts and reducing it to 17 volts. The arc light of the carbons is passed through condensers and then cooled by a three-inch cell of water or alum. The microscope part as shown has a mechanical stage with substage and achromatic Abbe Condenser of 1.00 n.a. The body of the microscope is three inches in diameter and twelve inches long between the mountings of the objective and eyepiece. The stage is movable in two directions, also may be advanced or receded by rack and pinion, and also by a fine movement for accurate adjustment of focus. The objective also has a movement of one inch by rack and pinion, and the drawtube furnished with rack and pinion movement may be extended three inches as a drawtube is extended in the ordinary microscope.

Insects may be killed with parts fully extended by throwing them into hot water or hot solution of corrosive sublimate.

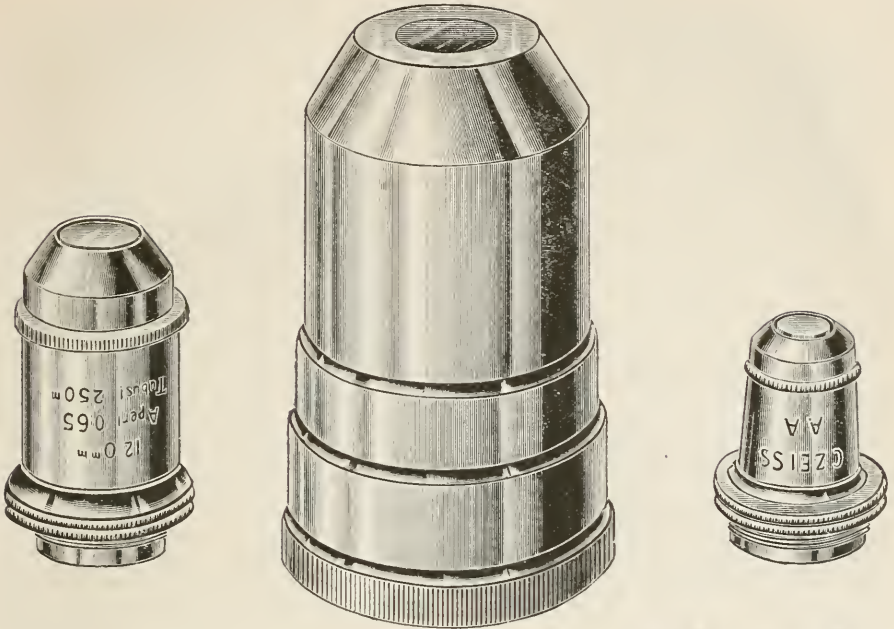

Fig. 1.

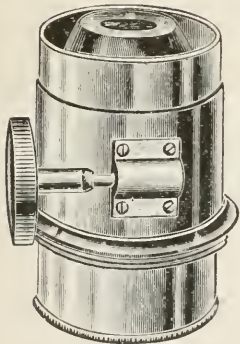

Fig. 2.

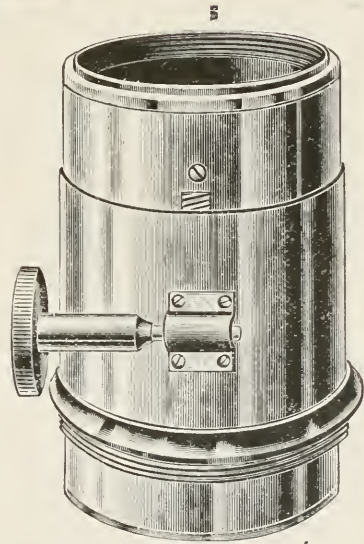

Fig. 3.

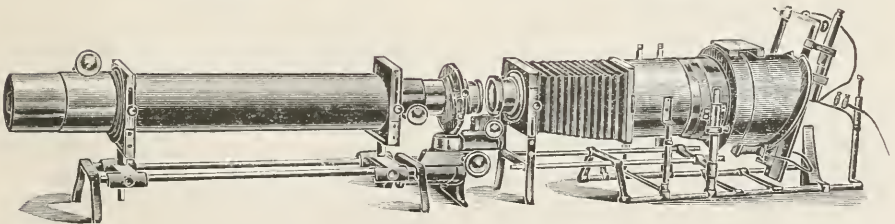

Fig. 4.

PROF. WHITE'S NEW PROJECTION MICROSCOPE OBJECTIVE.

Journal of Applied Microscopy.

Issued Monthly from the Publication Department
of the Bausch & Lomb Optical Co.,
Rochester, N. Y.

L. B. ELLIOTT, EDITOR.

Address all communications to
PUBLICATION DEPARTMENT,
BAUSCH & LOMB OPTICAL CO.,
ROCHESTER, N. Y.

One Dollar per Year. To Foreign Countries, \$1.25
per Year.

Entered at the Post-office, Rochester, N. Y., as second-class matter.

NOVEMBER, 1898.

In reply to the numerous inquiries and suggestions which have reached us, since the publication of the Journal began, in regard to a change in the size of type used, we are now able to announce that, beginning with the January, 1899, number, the reading matter will be printed in long primer type and the Journal bound in regular magazine form. The number of reading pages will also be materially increased. This improved form will permit the insertion of plates in any part of the Journal and will make its pages much more readable and pleasing in appearance.

The change involves a very considerable increase in the cost of publication, but the hearty support received during the past year will enable us to retain the present price of subscription.

* * *

A number of inquiries have been received regarding the purpose of the Journal Microscopical Directory. The directory is designed to be a list of all who are interested in the use of the microscope for any purpose whatever and who desire to place themselves in position to consult with and be consulted by others who are similarly interested. The names already received include workers in almost every branch of science, the industries, and many who use the microscope simply as a means of education and recreation.

* * *

Journal readers, when in Berlin, will hereafter be able to obtain the latest number at the Gebrueder Bornbraeger, Schöneberger Str. 17a, Berlin S. W., with whom we have completed arrangements to keep a supply of all numbers on hand and who will also receive subscriptions to be mailed direct from their Berlin office.

Current Botanical Literature.

CHARLES J. CHAMBERLAIN.

Books for review and separates of papers on botanical subjects should be sent to C. J. Chamberlain, University of Chicago, Chicago, Ill.

REVIEWS.

Juel, H. O. Parthenogenesis bei *Antennaria alpina*. Bot. centralbl. 74: 369-372, 1898.

The development of an embryo from an egg without fertilization is, to say the least, a rare phenomenon in plants. In Cryptogams the only well proven cases are *Chara crinita*, species of *Saprolegnia*, and perhaps *Marsilia Drummondii*. In Phanerogams, parthenogenesis has been reported in *Coelobogyne ilicifolia*, *Mercurialis annua*, and *Antennaria alpina*.

In *Coelobogyne* later researches show that the embryo is not developed from an egg cell, but from nucellus tissues. Kerner assumed parthenogenesis in *Antennaria* because female plants developed seed when no staminate plants were in the vicinity.

Juel reports that in *Antennaria alpina* generally only female plants are to be found, and that when male plants are obtained the pollen is either entirely lacking or feebly developed. The development of the embryosac proceeds in the normal manner as far as the eight-celled stage. The antipodals then divide to form quite a tissue, but the polar nuclei do not fuse. Both polar nuclei divide and contribute to the endosperm, so, like the egg, they are capable of division without the usual previous fusion. This seems to be a perfectly established case of parthenogenesis.

C. J. C.

Mottier, D. M. Beiträge zur Kenntniss der Kerntheilung in den Pollenmutterzellen einiger Dikotylen und Monokotylen. Jahrb. f. wiss bot. 30: 163-204, 1897.

This article contains an account of the deservedly popular safranin-gentian violet orange triple stain. Material was fixed in Flemming's chromic-osmic-acetic mixture, the proportions being as follows:

1 per cent Chromic acid	16 c. c.
2 per cent. Osmic acid	3 c. c.
Glacial acetic acid	1 c. c.

Stain in safranin ten to twelve hours, or over night, rinse in water, and then in alcohol to which a slight trace of hydrochloric acid has been added until only nucleoli and chromosomes remain red. Now stain in gentian violet three to five minutes, carefully rinse in water, and then stain in a weak, aqueous solution of orange G. for one quarter to one minute. Dehydrate in absolute alcohol and clear in clove oil. The clearing should be watched under a microscope lest the oil extract too much of the stain. The washing out may be regulated by

replacing the clove oil by cedar oil after the clove oil has worked for a short time. Mount in balsam.

C. J. C.

Balajeff, Wl. Ueber die Reductionstheilung des Pflanzenkernes. Ber. d. deutsch. bot. Gesell. 16: 27-34, 1898.

In the spring of 1897 Strasburger and Mottier thought they had found a reduction division (in Weissmann's sense) in the pollen mother cells of *Lilium* and *Podyphyllum*, but they almost immediately acknowledged that the work needed reinvestigation. The only other account of a reducing division in plants was that of the zoologist Ishikawa, who reports it in pollen mother cells of *Allium fistulosum*. Belajeff believes that the negative results of the botanists have been due to vague conceptions of division in vegetative nuclei. In this paper he described three forms of karyokinesis—the vegetative, in which the chromosomes in the mother star are U shaped, the heterotype with V, X, or Y shaped chromosomes (first division of pollen mother cells), and the reduction division with J shaped chromosomes in the second division of pollen mother cells. As these results are based almost entirely upon the shape of the chromosomes, other proof will be required before the conclusions can be regarded as more than a suggestive hypothesis.

C. J. C.

Bokorny, Dr. Th. Lehrbuch der Botanik für Realschulen und Gymnasien, pp. 226. Published by Wilhelm Englemann, Leipzig, 1898.

The object of this book is economy of time and work on the part of the student. After a rather detailed description of a few flowering plants, the gross morphology of the plant body is considered. The chapter on microscopic anatomy is short, only fifteen pages. The various groups are then presented, beginning with the Dicotyls and ending with the Schizophytes. The chapters on Physiology and Biology (Ecology) seem too short as compared with the structural and systematic parts. The book closes with a key to the most common families, genera, and species of local Angiosperms. The book is clearly written, but the taxonomic feature is unduly prominent.

C. J. C.

Mottier, David M. Das Centrosom bei Dictyota. Ber. d. deutsch. bot. Ges. 16: 123-128, 1898.

The tetraspore mother cells of *Dictyota dichotoma* furnished material for this work. The centrosome is staff shaped, usually bent with the convex side next to the nucleus, but not resting upon the nuclear membrane. The centrosome was never found in a depression in the membrane and was never found surrounded by a hyaline area. He does not know whether the centrosome has any phylo-

genetic relation to the blepharoplast, but states that the blepharoplast has nothing to do with spindle formation.

Centrosomes in the brown algae have previously been described by Swingle in *Stypocaulon* and by Strasburger in *Fucus*. Centrosomes in diatoms—sometimes classed with the brown algae—have been described by Smith, Butschli, and Lauterborn. It will be remembered that Mottier most emphatically denies the existence of centrosomes in the flowering plants.

C. J. C.

Treb, M. L'Organe femelle et l'apogamie the *Balanophora elongata*, Bl. Ann. du Jard. Bot. Buitenzorg. 15: 1-25, 1898.

This paper, illustrated by eight elegant plates, recorded some rather startling observations. There is no ovule, but an hypodermal cell gives rise to the embryosac, while the tissue above develops a slender prolongation, making the whole structure look like a moss archegonium. The embryosac develops in the usual manner as far as the eight-cell stage except that the antipodal nucleus may divide only once. The synergids and oosphere entirely disappear, while the upper polar nucleus, from the antipodal end of the sac, produces independently an endosperm of several cells. The embryo then develops from one of these endosperm cells, thus constituting a case of pure apogamy. The mature embryo is remarkably small, consisting of only five to ten cells.

C. J. C.

Janssens, Fr. A., and Leblanc, A. Recherches cytologiques sur la cellule de levure. La Cellule, 14: 203-243, 1898.

This seems to be the best work on the structure of the yeast cell which has yet appeared. The principal stains used were Malachite Green, Dahlia, Gentian Violet, Delafeld's Haematoxylin, and "Black Haematoxylin." (Black Haematoxylin differs from Delafeld's in that the ammonia alum of the latter is replaced by iron alum.) Every yeast cell contains a nucleus. During budding there is indirect division of the nucleus in some species, while in the common *Saccharomyces cerevisiae* and some others the division is direct. Cells about to form spores contain two nuclei which fuse. The resulting spore on germination shows a very peculiar form of division.

C. J. C.

Lyon, Florence M. A contribution to the life history of *Euphorbia corollata*. Bot. Gaz. 25: 418-425, 1898.

The development of rudimentary perianths about the "pistil" and "stamens" show that the so called flower is an inflorescence. This is further shown by the fact that the order of development is not that of a flower, but

of an inflorescence. The ovules are cauline in origin. The nucellus grows out into a long neck and finally makes a complete connection between the stigmatic cells and the embryo-sac, thus furnishing a continuous passage for the pollen tube. The synergids are unusually long and the antipodals very ephemeral. As a rule a single cell gives rise to all the pollen mother cells in a single microsporangium. Occasionally a pollen mother cell produces five or six pollen grains instead of four.

C. J. C.

Smith, Wilson R. A contribution to the life history of the Pontederiaceæ. Bot. Gaz. 25: 321-337, 1898.

Oogenesis and spermatogenesis are traced in detail. In *Eichhornia* the walls which usually separate the four potential macrospores are often suppressed. The failure of *Eichhornia* to produce embryos is probably correlated with its enormous power of vegetative reproduction. In *Pontederia* the tube nucleus frequently divides. This is the second case on record of the division of the tube nucleus of a pollen grain. After a comparative study, the author concludes that gametophyte characters are not of much value in tracing phylogenetic relationships, among the angiosperms.

C. J. C.

Van Tieghem, Ph. Structure de quelques ovules et parti qu'on peut tirer pour améliorer la classification. Jour. d. Botanique 12: 197-220, 1898.

The author concludes that the structure of the ovule affords a basis for marking out large divisions of Angiosperms and also for subdividing them. The number of integuments and the character of the nucellus are the features depended upon. The same writer employed these characters as a basis for classification in his recent third edition of the *Traite de Botanique*.

C. J. C.

Tauchnitz, Herm. Anatomischer Atlas der Pharmakognosie und Nahrungsmittelkunde Lieferung, 14: 289-306, pl. 66-70, Leipzig, 1898.

The Anatomical Atlas of Tschirch and Osterle has now reached number fourteen. The present number deals with *Flor. lavendulae Rhiz. rhei chinensis* and *europaei, Folia aurantii, Flor. aurantii, Fruct. aurantii immatur, Cort. fruct aurantii*. The present number gives a most excellent account of the anatomical details of the flowers of *Lavendula officinalis*. The detail drawings of *Rheum palmatum* and *R. officinale* are excellently executed and described. In *Citrus vulgaris*, the Schizolysigenetic glands are described, as well as other parts of the vival. The development of the ovule is given, as well as the polyembryony. The anatropous ovule contains two integu-

ments; the outer consists of two rows of cells, except the apical region where there are more; the inner of four. The outer wall thickens quite early in its development. The epidermal cells are elongated in a palisade-like manner. The inner integument never contains any starch; it is almost entirely absorbed, except the inner epidermis, which remains as a brown sheath ("braune haut"). The nucleus is mostly obliterated except a few rows of thick-walled layers of cells. The ripe seed consists of several embryos, maximum number six, of which three are capable of germination. The embryos of *Citrus* do not all originate in the embryo-sac, but only one is the product of the egg cell. The others are the so-called nucleolar embryos, which finally become detached from the wall of the nucleus.

L. H. PAMMEL.

Koch, Alfred. Jahresbericht über die Fortschritte in der Lehre von den Gährungsorganismen, 1895. Brannsdeweig, 6: 352, 1898.

Alfred Koch's Yearbook on the Organisms of Fermentation has now reached its sixth year. Six hundred and nine papers are reviewed under the following heads: (1) text books, (2) apparatus, (3) morphology of bacteria and yeasts, (4) general physiology of bacteria and yeasts, (5) fermentations in particular, the latter alcoholic fermentations, lactic acid, cheese and other fermentations of milk, appropriation of free nitrogen, nitrification, (6) ferments, the subject of the unorganized ferments; (a) diastase, (b) glukase, maltase, (c) invertise, laktase cytase are brought together in an admirable way. The work is most serviceable for workers except that it is two and a half years late.

L. H. PAMMEL.

Marliere. Sur la graine et spécialement sur l'endosperme du *ceratonia siliqua*. Etude cytologique et chimique, La Cellule, 13: 5-59, pl. 1-2, 1897.

Marliere, in a paper of considerable length, has given an account of the development, structure, and chemistry of the Carob, which has been the subject of earlier research work by Schacht and others. The author finds two integuments to the testa, especially in the micropylar region. Brandza, who studied the development of a few Leguminosae, maintains that the inner integument is absorbed. This consists of one to three rows of cells followed by remnants of the nucellus. The outer integument of the mature seed consists of the characteristic Malpighian cells. The light line is explained on a mechanical theory. There are two rows of osteosclerids simply called sclerids by the writer. One row below the Malpighian layer and one below the nutritive consist-

ing of thickened parenchyma cells. The bulk of the paper is devoted to the endosperm. The outer row of aleurone cells or Kleberschicht of German writers, is sharply limited, followed by a copiously developed mucilaginous reserve cellulose. The endosperm consists largely of a true mucilage, which colors yellow with iodine and sulphuric acid and produces a small amount of mucic acid when nitric acid is added. The mucilage is converted into three sugars, dextrose, levulose, and galactose. The endosperm contains 27.5 per cent. albuminoids, cotyledous 52.95.

L. H. PAMMEL.

Coupin. Sur la structure du micropyle des graines des legumineuses. *Revue generale de Bot.*, 9: 175-180, pl. 10, 1897.

Coupin has made a short contribution on a structure of the micropyle of *Vicia Faba*, *Cytisus Laburnum*, *Lupinus sp.* and *Arachis*. Coupin describes four types. In *Vicia Faba* the micropylar opening is cup shaped and the canal more or less obliterated below; in *Cytisus* a canal persists the entire length; in *Lupinus* the cavity is closed above and below, in *Arachis*, indistinct. In the adult and mature grains some prominent differences occur. The epidermis disappears entirely except in *Abrus*, where traces of it remain. The micropyle connects directly with the parenchyma of the testa and its intercellular spaces. This explains why the water enters more easily through the micropyle than the remainder of the integument.

L. H. PAMMEL.

RECENT LITERATURE.

Johnson, Duncan S. On the leaf and sporocarp of *Pilularia*. *Bot. Gaz.* 26: 1-24, 1898.

MacMillan, Conway. Orientation of the plant egg. *Bot. Gaz.* 25: 301-323, 1898.

Oltmanns, F. Die Entwicklung der Sexualorgane bei *Coleochaete pulvinata*. *Flora*, 85: 1-14, 1898.

Pfeiffer, Ferdinand R., V. Wellheim. Beiträge zur Fixirung und Preparation der Susswasser-algen. *Oesterreichische Bot. Zeitsch.* 48: Heft 2 and 3, 1898. A full resume is given in *Bot. Centralbl.* 73: 353-355, 1898.

Rieder, H. Wirkungen der Röntgenstrahlen auf Bakterien. *Münchener med. Wochenschrift*. No. 4, 1898.

Stevens, Wm. C. The behavior of Kinoplasm and Nucleolus in the division of the pollen mother cells of *Aselepias cornuti*. *Kansas Univ. Quar.* 7: 77-85, 1898.

Stoneman, Bertha. A comparative study of the development of some Anthracnoses. *Bot. Gaz.* 26: 69-120, 11 pl., 1898.

Wisselingh, C. van. Microchemische Untersuchungen ueber die Zellwände der Fungi. *Jahrb. f. wiss. Bot.* 31: 619-687, 1898.

Animal Biology—Current Literature.

AGNES M. CLAYPOLE.

Separates of papers and books on animal biology should be sent for review to Agnes M. Claypole, Sage College, Ithaca, N. Y.

In the following reviews an attempt has been made to take articles that have either a general interest to the student or teacher of animal histology, or else a special bearing on some of the most prominent of the many problems of cytology. In connection with both aims, points of technique of special interest are included. No attempt has been made to make an exhaustive summary of the many publications appearing during the month. It is hoped, however, to cover the ground sufficiently to make the department of interest to the investigator, teacher and student.

"*Archiv fur Mikroskopische Anatomie*," September, 1898. In the last number of this publication there are several articles of considerable interest. The first one is a study of the Chromatophores of *Cephalophodes* by Bernh. Solger. The method employed was to inject into a living animal a filtered solution of one-half per cent. solution of methylin blue in a six per cent. solution of salt; the injection being made either at the base of an arm or in the mantle. After this the animal was left in fresh sea water for two to four hours. In this time the skin was found well impregnated with the stain. Two questions are discussed: whether certain radial structures found connected with the chromatophores are really muscles, and whether certain structures staining deeply in methylin blue are nerves. The author answers both these questions in the affirmative and adds some interesting observations on the development of chromatophores.

B. Rawitz has the second part of an article on Cell Division: a series of studies on the spermatogenesis of *Scyllium canicula*. Careful observations were made on all the stages during development, and it was found that the centrosome was not a constant feature throughout development, but appeared definitely in the spermatid and was transformed into the middle piece of the spermatozoan. After the last division this structure becomes more and more prominent, and finally elongates to the characteristic middle piece.

Dr. S. Schwartz has made a study of the ganglion cells of the mammalian heart. He used the rat's heart, and made frontal, transverse, and sagittal sections of the whole organ. The stain chosen was Thionin, being used to bring out ganglion cells only. As a result of this study ganglion cells were found

Inquiries regarding any process or other practical subject may be sent for insertion in the News and Notes department.

only on a limited area of the auricle, more to the left than right of the inter-auricular wall. They were found in from four to five large groups between which lay scattered cells. The ganglion cell groups were surrounded by connective tissues and the cells separated from each other by this substance. In addition to the ganglion cells, there was on the surface a large but variable number of cells accompanying the nerves and vessels. They can be distinguished from the nerve cells by their deeper staining powers and the absence of a capsule and nuclear membrane. These cells have been in earlier studies confused with ganglion cells.

Dr. F. Ris has an article on the structure of the optic lobes of the bird. This is a very complete study of the different layers of the lobes. Six distinct layers were made out with subdivisions to some of these. The author does not give any definite answer to the question of contact or continuity.

Questions connected with the modern Cell Problems have been well summarized by Professor J. B. Farmer in "Nature." The cell is discussed as a structural unit; intercellular continuity of protoplasm, interrelations of nucleus and cytoplasm, and of the centrosome, phenomena of nuclear division, and the problem of reducing division, are all dealt with in a manner giving a good summary of the present situation of these questions.

Dr. T. A. Henneguy gives in Ranvier's new journal, "Archive d' Anatomie microscopique," an interesting report on some work done on the ciliated epithelium of the gills of Lamellibranchs. From his studies he concluded that the bases of cilia react to stains exactly like centrosomes, and considers them similar in nature to those structures.

In the same number of this new journal is a most interesting summary of the present status of knowledge of the origin of the central corpuscle or centrosome in fertilization. The author, D'Erlanger, summarizes all the important contributions to knowledge on this subject, giving in full, evidence for and against Fol's theory of the quadrille of the centrosomes. Evidence, he says, indicates most strongly the origin of the centrosome of the first cleavage spindle from the spermatozoon. Fol's theory has to be definitely discarded for metazoans. For Protozoans little can be said, as very little work has been done in this line except on a few infusorians. Several authors have compared the micronucleus of the protozoan with the centrosome and the macronucleus with the nucleus of a metazoan cell, but the researches on this point are too few to determine the ques-

tion. The author leaves the subject with a reference to the need for further work, both among plants and animals.

In the last number of the "Zeitschrift fur Wissenschaftliche Zoologie," there is an interesting article by R. Voltreck on the development of the ostracod egg, several species of Cypris being the forms used. In oogenesis definite stages were shown in the cells, a germinal zone and zone of growth. In the zone of growth, differentiation into egg cells and nutritive cells takes place. The egg cells are shown to possess yolk nuclei from the beginning of their growth till just before maturation takes place. Two polar bodies are formed, although these are parthenogenetic eggs. Cleavage is at first holoblastic up to twenty-two cells, after this it becomes more and more superficial and the blastoderm cells accumulate on the surface of the central inert yolk, gradually losing their separate identities, the cytoplasm becoming fused to a continuous sheet. Among other interesting points, the author notes the formation of the tetrads by the chromosomes of the nutritive cells, although these cells are destined to absorption by the ova. Finally he speaks of the "yolk nucleus," that much discussed and confused structure. In Cypris the structure is a true yolk nucleus having nothing to do with the centrosome. It has, he thinks, a direct connection with the activity of the nucleus, as shown by its position close to that part of the cell.

The "Zeitschrift fur Mikroskopie and fur Mikroskopische Technik" publishes a note by Dr. Goncalves Cruz of Rio de Janeiro, on a simple washing apparatus for histological purposes. It is so simple and effective for tissues that need prolonged washing that it is worth repeating. Two glass funnels, one larger than the other, a graduate-shaped glass dish, and a support with three adjustable clamps, form the main features of the apparatus. The smaller glass funnel is inverted and connected with a water pipe in such a way that a glass or metal pipe may project downward beyond the funnel to an amount nearly equal to the depth of the glass dish next to be used. This glass dish is placed below the inverted funnel and is of such a diameter that the latter will rest just inside the upper edge, and the space between the two is so adjusted that water will flow out freely, but pieces of tissue cannot. The second large funnel is placed erect below the dish, receives the overflow of water, and is connected with a waste pipe. The three parts are clamped in position on a vertical holder. The advantages of this device are in its simplicity and the fact

that most of its parts are of glass, avoiding any danger from the effects of metals on the tissues.

A. Kolossoro suggests a method for investigating epithelium by using injections of the following mixture into the vascular system of a newly killed animal, in which the system has been washed out with normal salt solution:

Osmic acid, 5 per cent sol. in water, 100 cc.

Salt peter 30 per cent. sol. in water, 5-1 cc.

Glacial acetic acid, 1cc.

Nitrate of Potash, 10-12 grms.

After two to three minutes, the injected part or organ is cut in small pieces and put for sixteen to twenty-four hours in ten per cent. tannin solution, which fluid is changed as often as any blackening is seen. The tissue is then washed in water and put in 70 per cent., 85 per cent., and 96 per cent. alcohol. It is cut in paraffin, and no staining is necessary. The points particularly well shown are the cell bridges.

M. Catois gives as a successful method of making neuroglia preparations by putting the tissue into osmic bichromate for ten to twenty hours, not for longer. In this tissue only the neuroglia cells are impregnated, and show sharply.

NEWS AND NOTES.

Minor notes on technique, personals, news items, notices of meetings of societies, conventions, etc., will be received up to the tenth of the month preceding issue.

Professor L. L. Lewis, Oklahoma Agricultural College, writes regarding the preparation of Agar where the autoclave is not a part of the laboratory equipment, as follows: "I have found it very difficult to filter Agar or Gelatin and have finally adopted the following method: use the white of an egg to free the media from sediment as near as possible, then pack the funnel full of absorbent cotton, first running through distilled water until the cotton forms a smooth, even layer in the funnel. Pour in the media while hot, and it will filter through clear and almost as rapidly as water."

For fixing zoophytes and polyzoa with their tentacles extended, Kleinenberg's picro sulphuric acid has been used. The animals are allowed to assume their natural position in a small quantity of water, when they are quickly deluged with a stream of the solution. This is continued until the water becomes a deep yellow. The specimen may then be removed, carried up through the different grades of alcohol and stained with any of the common stains. Picro carmine has been used with success.

The Indiana University, Biological Station, under the direction of Dr. Carl Eigenman, closed its work of the summer on Friday, August 19th. It continued during two terms of five weeks each, and there were engaged thirteen instructors and assistants. The following data show the remarkable success and growth of the station, since its establishment in 1895:

1895-19 students enrolled, 1 state represented.

1896-32 students enrolled, 4 states represented.

1897-68 students enrolled, 5 states represented.

1898-105 students enrolled, 8 states represented.

Demonstration of the Flow of Latex in the Stipules of *Ficus Elastica*.—The lactiferous vessels can readily be seen in the large red colored, deciduous stipules of *Ficus elastica*. The stipules envelop the young leaves in the bud, and, before falling off, they become somewhat transparent. If one of these stipules is removed a few days before it is ready to fall, the lactiferous vessels can be seen very distinctly by simply holding it on the stage of the microscope with its under surface up, and examining with the two-thirds and one-sixth-inch objectives. Since the latex will be flowing from the torn end of the stipule, the movement in the ducts will often be quite rapid, and appear not unlike the circulation of blood in the capillaries. Of course, the student must be cautioned that the movement of the latex is due entirely to the fact that it is flowing out of the open vessels, otherwise the impression might be obtained that the latex had a circulatory movement. J. H. S.

O. S. U. Bot. Lab.

Nuclear division in *Spirogyra* has recently been thoroughly investigated by L. Mitzkewitsch.* After an admirable discussion of the work of previous investigators, he gives his own results. The nucleolus, which in *Spirogyra* has a definite membrane, seems in the resting condition to be homogenous, but as division proceeds is seen to consist of intensely staining granules—the Chromosomes—and a less deeply staining substance, perhaps linin. The nucleolar membrane soon disappears, and the nucleolus puts out granular processes which reach to the periphery of the nucleus. These processes are soon withdrawn and achromatic threads appear within the nucleus, apparently a continuation of achromatic threads which have appeared in the polar plasma heaps

*Flora, Band 85 pp. 81-124, 1898.

outside the nucleus. The chromosomes become arranged in a single layer in the nuclear plate, the chromosomes split and the two halves, somewhat connected by granular strands, pass to opposite ends of the cell. After the new nuclear membrane is formed, the material of the nuclear plate still shows the intensely staining chromosomes imbedded in a less deeply staining mass from which processes reach to the nuclear membrane. These processes are withdrawn, the chromosomes gradually become indistinguishable from the rest of the mass, the nucleolar membrane appears, and the nucleolus and nucleus present the usual aspect of the resting condition.

The material for this work was killed in Flemming's fluid (some other killing agents were also used), washed in water and dehydrated by adding alcohol drop by drop at intervals of a minute or more. The transfer to xylol and from xylol to paraffin was equally gradual. Paraffin sections were cut with a microtome and stained in the most approved manner. The excellence of the paper is doubtless due in great measure to the ingenuity and carefulness of the technique. C. J. C.

In the botanical department of the University of Nebraska some changes have been made in the courses offered. As now arranged, after a year of "general botany," the student has four lines of work open to him, viz.: I, Histological; II, Taxonomic; III, Physiological; IV, Technical. In the histological line with which we are more particularly concerned here, the courses, which are a semester in length, are as follows:

Cytology.—A study of the microchemistry of the placet cell, and the details of karyokinesis, with especial reference to technical details.

Histology.—A comparative study of tissues and tissue-aggregate, and of the inter-relations of tissue systems, together with the technique of differentiation processes.

Embryology.—A study of the development of the ovule, embryosac, and embryo of selected spermatophytes.

Histogenesis.—A study of the origin and development of tissues and tissue aggregates in the principal histogenetic types of pteridophytes and spermatophytes.

Advanced Cytology.—A critical study of the cytological phenomena of sporogenesis and fecundation, together with a detailed consideration of technical formulae and methods.

All are four-hour courses, each including eight hours of laboratory work a week, in addition to four lectures or conferences. C. E. B.

The department of Biology in Wabash College is in charge of M. B. Thomas, Botany; D. Bodine, Zoology and Geology. By recent additions, the laboratory now has nearly a full set of the delicate appliances made by Prof. J. C. Arthur for work in plant physiology. A course in bacteriology of one term is now given for the benefit of the medical preparatory men. A thorough drill in micro-manipulation precedes all of the advanced courses in botany and zoology. Work in the summer school has been in charge of Mr. A. A. Taylor. An automatic electrical thermostat, made in the department, has been in use for one year, and has given perfect satisfaction. The cost is very little and the appliance can be made by anyone.

A correspondent desires information regarding the technique of mounting small Coleoptera, and parts of insects. Can someone furnish the desired information?

Difficulty is sometimes experienced in imbedding small bodies, such as spores and pollen grains, for sectioning in large quantities. I have used successfully the following method, which may be new to some. The spores are placed in a homeopathic vial and treated in the ordinary way for paraffin imbedding. The spores will sink to the bottom and the different reagents can easily be poured off. When the material is ready the bottle is filled with paraffin, and after the spores have settled to the bottom it is quickly cooled off. When the paraffin has hardened the bottle is broken, and with a little trimming the block is ready for the microtome. J. H. S.

Botanical Laboratory, Ohio State University.

PHAGOCYTOSIS.

In demonstrating phagocytosis to classes in Histology the following method has many advantages, being simple and efficient. A rat is rendered unconscious by means of chloroform. Into its abdomen is injected, by means of a hypodermic syringe, about one cubic centimeter of the following solution:

Lampblack	1 gram
Gum arabic.....	1 gram
Salt	6 grams
Water	20 cubic centimeters

The rat is then allowed to recover from the effects of the chloroform. After twenty-four to forty-eight hours the rat is killed and cover glass smears are made from the abdominal lymph. The smears are allowed to dry, and are then fixed by immersion from twenty to sixty minutes in ether-alcohol, equal parts.

They are then stained, as used, in the following manner:

First—1-2 min. in a 2 per cent. solution of erythrosin in 67 per cent. alcohol.

Second—3-4 min. in Gage's Haematoxlyn.

The result is a preparation containing a large number of Leucocytes, nearly all of which contain particles of carbon which they have taken up from that injected into the abdominal cavity.

LIVING CILIA.

In demonstrating living cilia, recourse is usually taken to the amphibians or some other of the lower vertebrates. The reason is that it has long been a current theory that the cilia of cold-blooded animals live longer than those of mammalia after the death of the animal, and hence afforded better opportunity for observation: This does not prove altogether true. During the past month ciliated epithelium was taken from the trachea of a young cat. It was placed immediately in some of the clear liquid obtained from puncturing the eyeball, covered, and sealed with castor oil. In a few moments rapid motion of the cilia could be distinguished. This motion rarely ceased before eight hours had elapsed. A few preparations retained their activity for fifty-six hours. This is as long as amphibian cilia continue to move. Thus it seems that mammalian ciliated epithelium offers as good material as amphibian for the purpose of showing the action of living cilia.

C. M. M.

St. Louis Microscopical Society met October 15th, and after transaction of usual business proceeded to the scientific programme.

Dr. Bremer reported a doubtful ulcer of the tongue, examined by himself, to be a syphaloma undergoing degeneration. Excision of the tongue was recommended as a means of relieving the pain caused by tissue changes affecting sensitive nerves.

Dr. Alt read a paper on Adenoma of the ciliary body, in four cases he examined, the finer structure of the tumor resembled a gland whose efferent duct had been obstructed, the epithelium had sprung from that of the pars ciliaris retinae. None of these tumors awakened the thought of malignancy. In no case had blindness nor pain been caused, nor did any of these tumors resemble anything hitherto described.

The society met again on October 27th, and after the customary business routine Dr. Crandall presented the kidneys and bladder of a patient who had died after suffering two years from cystitis. From the left ureter, Dr. Crandall had made

pure cultures of bacterium coli communis.

Dr. Johnson presented the lungs of a child who had died at the age of three months as a result of pulmonary hemorrhage. The case was presented as one of congenital tuberculosis following bladder tuberculosis in the mother, in whose urine the tubercule bacilli had been found.

W. B.

Several years ago I accidentally left some material of *Aster Novae Angliae* in the paraffin bath at 52 degrees C. for nearly a week. I supposed of course that the material would be ruined, but found that it was in very fair condition. Since that time I have frequently left material in the bath for several days, and sometimes found it in really fine condition. Material forgotten by pupils has also proved to be in fine condition after such a prolonged bath. We have never had confidence enough in such prolonged treatment to try it intentionally with material known to be well killed and fixed.

We seldom keep material in the bath for more than two hours, and delicate tissues are thoroughly infiltrated in much less time. It may be possible that tissues which show shrinkage or plasmolysis after an hour's bath may regain their normal form if the bath be prolonged for days. I should be glad to hear the experience of other workers.

C. J. C.

In the Botanical laboratory of the University of Nebraska we have been using, for some years, a convenient reagent bottle which appears not to be in general use, and which has commended itself to

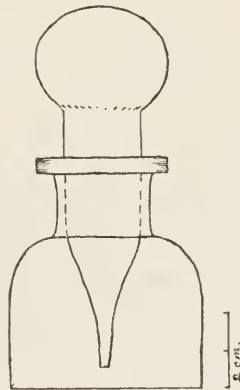

us above all others which we have tried. It consists of a rather broad base (50 mm.) with a wide mouth (20 to 22 mm.) into which is fitted a hollow glass stopper as shown in the accompanying figure.

The stopper is tapered below to a narrow point, with an opening about one millimeter in diameter, while above it lies a bulbous expansion which is not perforated. In using this bottle, there should be enough of the reagent in the bottle to permit a few drops to enter the lower end of the pointed tubular stopper. When the stopper is taken in the hand, it is easy by a little pressure of the warm hand upon the thin glass of the bulbous expansion to warm the air sufficiently to drive out the exact amount of the reagent desired.

From the fact that these bottles are not given in the lists of supplies for botanical laboratories, I infer that they have not come into general use for this purpose. They have been known to chemists for some time as Acid Drop bottles.

C. E. B.

University of Nebraska.

One of the chief difficulties encountered in demonstration work with the microscope in high-school classes is the uncertainty as to whether the students are actually looking at the structures the demonstrator is speaking about. In order to insure uniformity of observation, the following method suggested by a physician in this city has been used. The upper lens of the eyepiece is removed, and a piece of human hair sufficiently long to project from the diaphragm in the eyepiece out to the center of the opening is attached to the upper surface of the diaphragm by means of a small drop of mucilage or paste. This hair does not

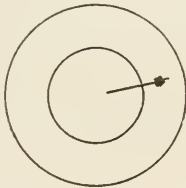

interfere in any way with the eyepiece, and after one is a little accustomed to it, it is not noticed at all. By means of it, however, objects or structures can be arranged so that the hair will point exactly to the spot which it is desired the student should observe. The accompanying diagram will serve to show what is meant.

E. R.

Pittsburg, H. S.

Everyone has had occasion to complain about the common balsam bottle, which is always getting its cap stuck down so tightly that the efforts of the impatient student result in a disagreeable break.

Broken caps are the rule, I think, with balsam bottles which have been in use for a month or so. Several years ago it occurred to me that there was no good reason why these caps should not be made of metal, and casting about I found a mucilage bottle cap of about the right size, and made a trial of it with excellent results. That metal cap has outlasted ever so many glass ones, and promises to continue with us for many years to come. I have several times called the attention of dealers to this desirable improvement, but thus far they have not placed any metal capped balsam bottles on the market. Possibly they may not be profitable for the dealers, because they will last too long, but they will be very handy for the men who work in laboratories.

C. E. B.

The University of Nebraska.

The Engleman Botanical Club is making efforts to secure the city protection for the St. Louis trees, many of which are dying from neglect and ill use.

Professor L. H. Pammel, of the Iowa Agricultural College, is spending a part of his vacation in research work at the Missouri Botanical Garden. Several other specialists are expected soon.

In working on the dissemination of *Osuea Orbata* by wind, Mr. Herman von Schneck of the Shaw School of Botany has devised an arrangement for securing a blast of wind that can be controlled, varied, and measured for testing the effect on plants. The machine is a fan blower run by steam, and can produce a current of hurricane velocity. It will soon be further described by von Schneck.

The method of preserving notes on cards arranged alphabetically or systematically in drawers is more cumbersome than some are willing to employ; while to preserve them in note books following only the sequence of time in which they are made is not convenient. Some workers scratch down notes upon whatever paper happens to be at hand, and then cannot preserve them in any satisfactory shape. A good way is to paste such notes upon sheets of convenient size, say, for an octavo or quarto volume, in one side of which two holes have been punched. The sheets can then be bound in a cover by tying through with a small cord and arranged according to any desired classification and put upon the library shelves with other books where most convenient. Other sheets can be put in at any time in the proper place. A better way is to have the uniform sheets of paper at hand, and make the notes upon them directly.

J. N.

Missouri Botanical Gardens.

Journal of Applied Microscopy.

VOLUME I.

DECEMBER, 1898.

NUMBER 12

The Persistence of Bacteria in the Milk Ducts of the Cow's Udder.

Read at the twenty-first annual meeting of the American Microscopical Society, Syracuse, N. Y.

The constant presence of bacteria in freshly drawn milk is a matter of considerable importance. The fact that milk when drawn from the udder may contain bacteria is of the greatest interest in connection with the observance of measures designed to reduce the bacterial content of milk to the minimum. Here, if that fact be true, is one source of the infection of milk which can not be eliminated by the exercise of precautions during the milking or the subsequent processes to which it is subjected.

The earlier investigations undertaken to throw light on the question of the presence of bacteria within the healthy udder consisted in counting the bacteria in samples taken during different periods of the milking. Schultz¹ found a decrease in numbers as the milking progressed. Lehmann² obtained like results. It might be concluded from the work of Schultz and Lehmann that the teats, or at most the lower portion of the cistern, only contain bacteria.

Gernhardt³ found a larger number in samples from the middle of the milking than at the beginning, although some of the samples from the last milk drawn were sterile. To explain his results, Gernhardt suggests that the bacteria make their way up through the milk ducts of the teats, through the cistern, and into the smaller ramifications of the ducts which connect the cistern with the ultimate follicles. Such an assumption explains the wide variation in numbers obtained by him.

Von Freudenreich⁴ states that, when in the udder, milk is free from bacteria except when the milk glands are in a diseased condition. He mentions the fact as having been demonstrated by Pasteur, who drew samples directly from the cistern by means of a sterile cannula. On the other hand, Bolley and Hall⁵ compared the species of bacteria in the milk of several cows, the samples taken through a sterile milking tube inserted into the milk cistern.

Russell⁶ found that bacteria are present in the udder proper in case of mastitis. In Russell's Dairy Bacteriology we find the following: "How far these different forms of germ life are able to penetrate into the healthy udder is as yet unknown. In all probability, the glandular tissue of the udder is not affected, although it is possible that microbes might work their way up the open channel of the teat into the udder proper."

Grotenfelt⁷ says that "When the milk is drawn from the udder of a healthy cow it is germ free, or sterile. The original sterility of normal milk is due to the fact that the bacteria can not gain access to the milk glands from without as long as the udder is not injured in any way." F. W. Woll, the translator of Grotenfelt's work, adds in a footnote: "The bacteria in the milk cistern will be largely washed

4. Ed. von Freudenreich. Dairy Bacteriology, translated by J. R. A. Davis. Page 36.

5. Bolley and Hall. Cent. für Bakt. und Parasit. II, Abt. I: 795, (1895); Association Ag. Coll. and Exp't Stations (1895); Abstract in Experiment Station Record, Vol. VII, No. 11, p. 991.

6. H. L. Russell. Dairy Bacteriology, pp. 42, 43.

7. Gosta Grotenfelt. The Principles of Modern Dairy Practice, translated by F. W. Woll, p. 23.

1. Leopold Schultz. Archiv. f. Hygiene, B. S. XIV (1892).

2. Lehmann. 17te Versammlung d. deut. Ver. f. öffent. Gesundheitspflege.

3. Gernhardt. Quant. Spaltpilzunters. d. Milch, Inaug. Dissert. Univ. Jurjew.

out by the first milk drawn, but not all removed until milking has progressed some time."

Rotch⁸ concludes that the few cases in which contaminated samples were obtained from the strippings, were due to faults in technique and not to bacteria from the interior of the udder.

Moore⁹ reviews the conclusions of Schultz, Gernhart, and Rotch and gives the results of his own investigation. In every examination made he found the last milk from at least one quarter of the udder to contain bacteria. In concluding his paper Moore suggests that a bacteriologic examination of the larger milk ducts and of the acini themselves might throw some light upon the assumption of Gernhart. Such an investigation was rendered impossible at the time on account of his inability to procure the udder of a freshly killed milch cow.

That sterile samples may frequently be obtained directly from the teat is a fact that has been demonstrated by many investigators. But the frequency with which these same workers have failed leads to the conclusion that the last milk contains only a few bacteria and which may, or may not be contained in a given small sample. Schultz, Gernhart, Russell, Rotch, and Moore have all been unable to get sterile milk in every case. Information is not at hand concerning the amount of milk taken for a sample, except that Moore took 50 cc. of the last milk. Conn¹⁰ suggests that the reason the earlier workers obtained sterile milk so readily was because they did not collect large samples. He says: "Essentially the same facts have been demonstrated in regard to human milk. * * * Honigmann¹¹, Knochenstiern¹², Ringel¹³, and Palleske¹⁴ have all independently found that it is impossible to get human milk from the mammary gland in such a way as to be sterile."

Von Freudenreich¹⁵ states that he failed to obtain sterile milk in large quantities although the udder was

washed and smeared with lard to prevent contamination. In an attempt to collect ten liters of sterile milk for an experiment in cheese making, he was unable to reduce the number below 212 bacteria per cubic centimeter. He calls attention to the ease with which a few cubic centimeters are collected, using the same precautions, but he does not recognize the presence of bacteria from within the udder.

Those who believe the last milk to be absolutely sterile when drawn from the teat must necessarily explain the constant presence of bacteria in the fore-milk. The explanation is substantially as follows: Bacteria in the air or in stable filth accidentally gain a foothold in the milk remaining on the end of the teat after milking. The favorable conditions for bacterial growth offered by the ducts favor the multiplication of the invading bacteria, which increase so rapidly as to account for the presence of the multitudes always found in the fore milk. Experiments by the writer have shown that it is possible for this to occur under certain conditions, but the more probable explanation is embodied in the results of the investigations about to be described. These will be treated under three separate heads, as they have in common only the fact that they lead to the same conclusion.

THE PERSISTENCE OF CERTAIN SPECIES OF BACTERIA IN THE FORE MILK.

The Work of Bolley and Hall is the only investigation on the subject that has come to notice. Samples of milk were taken by means of a sterile milking tube inserted through the duct into the milk cistern. Some species were found common to both the first and the last milk drawn. Only one organism was found common to the milk of all the animals examined, that one having no effect upon the milk. The writers conclude that a given form, once present, may be quite constant in its occupancy of the udder in an individual.

In the investigations which I have made to determine the nature of the milk duct flora, the following methods were adopted. Before collecting samples, the udder and flanks of the cow were thoroughly moistened to prevent the dislodgment of dust by the movements of milking. In addition, the teats were moistened with a solution of mercuric chloride. Samples were drawn directly from the teat into sterile test-tubes, which were provided with cotton plugs. In this respect the work of the writer differs from that of Bolley and Hall. Cultures were made immediately after collecting the samples. Five two hundred and fiftieths (5-250) of a cubic centimeter of

8. Dr. T. M. Rotch. Transactions of the Association of American Physicians. 1894.

9. V. A. Moore. Preliminary Investigations Concerning the Number and Nature of Bacteria in Freshly Drawn Milk. Twelfth and Thirteenth Annual Report of the Bureau of Animal Industry, U. S. Dep't of Agr., p. 261.

10. W. H. Conn. Bull. No. 25, U. S. Department of Agriculture, Office of Experiment Stations, p. 9.

11. Honigmann. Ztschr. Hyg. 14 (1893), p. 207.

12. Knochenstiern. Inaug. Diss. Dorpat. (1893).

13. Ringel. Munch. Med. Wochenschr. (1893), p. 513.

14. Palleske. Virch. Arch., 130 (1892), p. 135.

15. Ed. von Freudenreich. Landwirtschaftliches Jahrbuch der Schweiz. (1891) II, p. 18.

milk was found, in general, to introduce a sufficient number of bacteria for convenient study upon a plate culture made in 15 cc. of media. For a time both gelatin and agar plate cultures were made, but the use of the former was discontinued, as agar was found to be more

The milk of each of the four teats of a cow was examined on two successive days, and after a lapse of two weeks, some of them were examined upon four more days. Four or possibly five species were observed, only one being common to the four teats. Although the bacterial

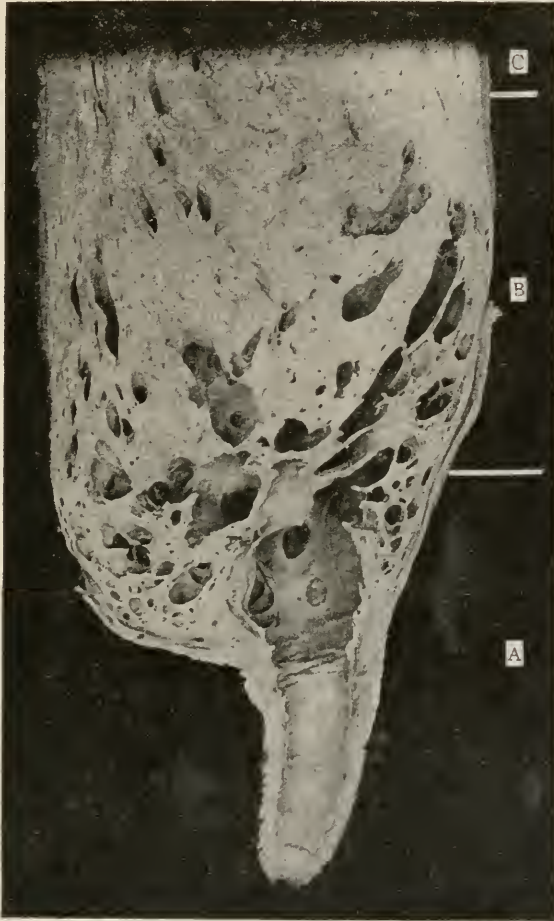

A photograph of a section through the teat and one quarter of the udder of a cow. The parts represented by the letters A, B, C indicate the three arbitrary divisions into which the gland was divided for purposes of examination.

satisfactory. The total number of colonies did not appear until after several days in the incubator at a temperature of 37.5 degrees C. The plates were then examined and sub-cultures were made from the colonies of the apparently different species. The various forms of colonies were carefully described and the number of each recorded.

flora of each of the teats differed from that of its neighbors, the same species were found to persist in the same teat from day to day. They were not present in the same relative numbers on each occasion.

The milk of another cow was examined on five occasions, covering a period of eight months. In the milk of this animal

but three species of bacteria were found. On the first day that the milk was examined, streptococcus was found to predominate in numbers in all four of the teats. The other two species occurred only occasionally, but in the later examinations they were found to exceed the streptococcus in number.

The presence of streptococci in milk from a normal udder is, in the experience of the writer, unusual. None have been found in the milk of eight cows in the same stable, or for that matter, in any examination of fore milk from cows elsewhere. The persistence of the streptococcus in the milk of the one cow is therefore of special significance.

The mathematical probability that the same organism will invade the same sterile milk duct, even twice in succession, is infinitely slight. It is therefore necessary to seek other explanation for the constant presence of bacteria in the fore milk, when we consider the persistence of species in the milk of certain cows or in particular quarters of the udder of the same cow.

AN EXPERIMENT IN COLONIZING THE CISTERN WITH BACTERIA.

With reference to determining the possibility for an organism to persist in the cistern for a considerable period it was determined to introduce, into one quarter of the udder, a culture of an easily distinguished bacillus. For this purpose *Bacillus prodigiosus* was selected because the red color of its growth on agar would render its presence in milk easily recognized when cultures were made. Four cubic centimeters of a bouillon culture were introduced into the cistern by means of a hyperdermic syringe lengthened with a milking tube. Both the milking tube and the syringe were scalded to guard against introducing any other micro-organisms along with *prodigiosus*. It was known from work already done that the organism in question was not a natural inhabitant of the udder with which the experiment was being made.

The use of the milking tube, as is nearly always the case, occasioned an inflammation of one side of the udder. The inflammation is attributed to the use of the milking tube rather than to *Bacillus prodigiosus*. The threatened obstruction of the teat by the accumulation of irregularly shaped masses of casein, rendered it necessary to frequently draw out the purulent liquid from the diseased quarter of the udder during the two following days after which the inflammatory condition subsided. Plate cultures were made each day. On the day following the inoculation, ten colonies of *Bacillus prodigiosus* appeared on the plates. Although the same amount of milk was

used in making the cultures on the days following, the number of colonies was observed to decrease in number. On the sixth day, the colonies of that bacillus, ceased to appear. During the whole period, with the exception of the first two days, colonies of the native bacterial flora were observed in each plate culture.

The fact that an organism selected at random, without considering its fitness for inhabiting the udder, should succeed in persisting there for six days is significant. The experiment demonstrates the fact that frequent and thorough milking may not remove all bacteria from the udder. That other species of bacteria, better fitted for that environment, are able to persist in the udder for longer periods seems highly probable.

A BACTERIOLOGIC EXAMINATION OF THE GLANDULAR TISSUE OF THE UDDER.

The writer is indebted to Dr. Moore for the suggestion of this line of work and for the privilege of associating with him in an investigation based upon it. A partial report of the results obtained has been published elsewhere¹⁶. In attempting to draw conclusions from the facts which have already been presented, the writer finds himself unavoidably influenced by the facts brought to light in the work to which reference has been made. That his conclusions may not appear to be based upon a less firm foundation of fact than is the case, he feels justified in here referring to the joint labor.

The fundamental method underlying the investigation consisted in making a large number of cultures directly from freshly exposed glandular tissue. Sterile tubes, tubes containing about 15 cc. each of gelatin, and some containing slanted agar were taken to the place of slaughter.

The purpose was to compare the bacteria found in the fore milk with those which might be found in the udder. Samples of the fore milk and in one case of the strippings, were taken immediately before the slaughter. In order to obtain more definite results, each quarter of the udder was arbitrarily divided into three divisions. The first (A) included the teat and milk cistern. The second and third divisions (B,C) included horizontal zones of equal thickness constituting the remaining portion of the udder. (See illustration).

Each cow was milked before killing. Immediately after slaughtering the cow, the udder was carefully removed. The skin was reflected and a flamed knife was used to make a dorso-ventral incision several inches in depth in one quarter of

16. V. A. Moore and A. R. Ward. Bull. No. 158, Cornell University Agricultural Experiment Station. January, 1899.

the udder. Samples of milk were collected in sterile test-tubes as it welled out of the cistern and its smaller ramifications. In making cultures from the glandular tissue, care was taken to prevent milk of the ventral region from coming in contact with the freshly exposed surfaces. Bits of tissue were detached with flamed scissors, and transferred to culture media by the use of a flamed platinum loop. Tubes of gelatin and of agar were inoculated in this manner from each of the three arbitrarily designated divisions of the quarter. The same procedure was repeated with each of the other three quarters of the udder. Cultures were made from the udders of six cows in the manner described.

Upon returning to the laboratory the gelatin was liquefied at a temperature not exceeding 37 degrees C and poured into sterile Petri dishes, where it again became solid. Agar plate cultures were made from the milk samples, and, together with those slanted agar cultures already inoculated, were placed in the incubator. The agar plate cultures were designed to be used as a check upon the reliability of the conclusions reached from an examination of the other cultures. For instance: it might be possible that organisms appearing to have been obtained from the interior of the udder may have lodged upon the bits of tissue during the transfer. The identity in cultural and morphologic characters of bacteria found in cultures made from the fore milk and the glandular tissue of the udder would eliminate a source for false conclusions.

The tubes of slanted agar, after standing in the incubator for several days were examined particularly with reference to the presence or absence of growth. Nearly all of the media which had been in contact with material from the udder showed growth. Note was taken of the color and character of the growth of the colonies and sub-cultures were made.

The gelatin plate cultures were in like manner examined, furnishing a more satisfactory method for obtaining pure cultures. With these, a direct comparison made it possible to trace the presence of the same organism in the three localities. In order to prove that these identities existed, sub-cultures were made for a more detailed comparison later. The plate cultures made from the milk were examined and sub-cultures were made from all of the apparently different colonies.

By comparing cultures from the various sources, it was found that the same organism frequently occurred in the fore milk and in each of the three parts of the udder. (See illustration.) Most of the bacteria obtained in pure cultures were

found to belong to one of three species of micrococci. Cultures of the three species were obtained from a sufficient variety of sources to demonstrate their general distribution throughout the udder.

The apparently healthy udders of six milch cows were in that manner found to contain bacteria in the depths of the milk secreting tissue. By the methods employed, it was impossible to detect any difference in the relative numbers of bacteria present in the three regions of the udder.

The evidence at hand indicates that the teats and the greater portion of the udder may normally contain bacteria. It also seems highly probable that a few at least of the organisms found in the udder remain there after each milking, becoming the progenitors of the organisms found to be present in the milk when drawn. This conclusion seems to be supported by the following facts:

1. Certain species of bacteria have been found to persist in particular quarters of the udder for considerable periods of time. This controverts the statement that the milk ducts are sterile at the close of the milking, becoming tenanted from the outside by any organisms which by chance come in contact with the end of the duct.

2. It is possible for bacteria to remain in the udder and not be ejected along with the milk. This has been proven possible in the case of one organism. A culture of *Bacillus prodigiosus* has been introduced into the milk cistern and has succeeded in persisting there for six days, as was shown by its presence for that period in the milk of that quarter of the udder.

3. Cultures of bacteria have been obtained by Dr. Moore and the writer from the glandular tissue of the udders of freshly killed milch cows. Identical species of micrococci were obtained from the milk and from the glandular tissue of the udder.

4. It has not been shown by the investigations published up to this time that the last milk drawn is always sterile.

ARCHIBALD R. WARD.

From the laboratory of Comparative Pathology and Bacteriology, New York State Veterinary College, Cornell University, Ithaca, N. Y.

Centrifugal Milk Analysis.

For most practical purposes the butter fat is the only component of milk which it is necessary to determine quantitatively. The fat is the most important milk component from a commercial point of view, and in human nutrition it is the best index to the food value of the milk,

both on account of its own high nutritive value and because a milk rich in fat will generally be rich in other solid constituents as well. The determination of fat in milk was until recent years always done gravimetrically, and therefore required the facilities of chemical apparatus and expert knowledge. During late years a number of different practical methods for the estimation of fat in milk have, however, been published, most of which give accurate results when properly manipulated. These methods are in general based on the same principle, viz., the addition of one or more reagents which dissolve the non-fatty solid components of the milk and set free the milk fat, which is then separated by centrifugal force, and its volume or weight determined by special devices.

In this country the so-called Babcock Milk Test,* invented by Dr. S. M. Babcock, professor of Agricultural Chemistry of this University, has been adopted in preference to other practical milk tests, in creameries and cheese factories as well as in milk laboratories. The cause of the general adoption of this test is doubtless to be found in its simplicity, cheapness, and ease of manipulation. Briefly stated, the test is operated as follows: 17.6 cubic centimeters of milk is measured into a special milk-test bottle, an equal quantity of commercial H_2SO_4 (specific gravity, about 1.83) is added, and after mixing the two liquids, the test bottle is placed in a centrifugal machine and whirled for four minutes; hot water is then added to the bottle to bring the fat into graduated narrow neck of the bottle, and after a second whirling of one minute, the per cent. of fat in the milk is read off from the scale of the test bottle.

A determination of fat in milk by this method takes less than fifteen minutes, and when care is taken in sampling the milk and reading of the result, is accurate to within one-tenth of one per cent. Babcock testers are now placed on the market by many manufacturers of dairy supplies and at a remarkably low price, thanks to sharp competition among the manufacturers. The testers are either hand or power (steam or motor) machines and built to hold from two to thirty or more test bottles at a time. The number of revolutions at which they must be run ranges from 800 to 1,200 per minute, according to the diameter of the testers. A very satisfactory six-bottle hand tester, substantially built and with complete outfit, may be bought for \$9.00.

Where milk analyses are made regularly and in a considerable number, a special machine like those just described is to be recommended. In many physio-

logical laboratories or in case of practicing physicians, the number of samples of milk analyzed is, however, small and these come only occasionally, so as not to warrant the purchase of a new apparatus for this special purpose. It occurred to the writer that the small centrifuge in use by physicians for the examination of urine, sputum, blood corpuscles, etc., might also be adapted for milk analysis by the Babcock method, with proper changes in glassware and quantities of milk and acid measured out. On further examination it was found that the spiral-gear "urinary centrifuge" manufactured by Bausch & Lomb Optical Co. had already been adapted for milk analysis by the so-called Leffmann & Beam method;** this method is similar to the Babcock test, with the difference that the separation of the fat in the former method is effected by a mixture of acids, a small quantity of amyl and methyl alcohol being added to facilitate the separation.† The apparatus recommended for use by this method was found to give correct results also in case of the Babcock method, after some slight modifications were introduced. The centrifuge with pipette and milk-test bottle are shown in the accompanying illustrations.

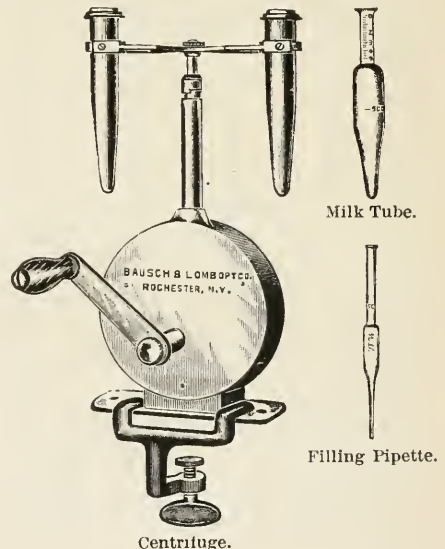

The method as worked out by the writer is as follows: Two cubic centimeters of milk is measured into the test bottles and enough of concentrated sulphuric acid (specific gravity, 1.84) is

**Centrifugal Analysis, special catalogue, 32 pp.

†Bul. 21, Vermont Experiment Station; Leffmann & Beam, Analysis of Milk and Milk Products, p. 26.

*Bul. No. 24, Wisconsin Experiment Station.

added to bring the total volume of the liquids to the shoulder of the test bottles; the milk and acid are then mixed thoroughly, and when a homogeneous dark mixture has been obtained, more acid is added until the liquid reaches the top of the scale on the neck of the bottles. The contents are again mixed by inverting the bottles a couple of times, keeping the mouths of the bottles tightly closed by pressing over them a small piece of sheet rubber. The bottles are then whirled for one to two minutes, and readings taken at once. If the contents have contracted by cooling during the centrifuging, so that the fat column is below the graduated scale, the bottles are placed in hot water for a few minutes prior to reading off the results. Instead of using concentrated sulphuric acid, the commercial acid (specific gravity, 1.82-1.83) may be used, provided the milk-acid mixture be kept in water of about 200 degrees F. for a few minutes before the bottles are whirled. The ordinary time of four minutes for whirling the best bottles in the Babcock test may be reduced to less than two minutes with the urinary centrifuge, owing to the high speed reached in this machine.

On account of the small quantity of milk that can be handled it is but natural that the determination of fat in milk by means of this centrifuge requires some nicety of manipulation not called for when the test is made with regular Babcock test bottles and test machines, when nearly nine times as much milk is taken. After a little practice there will, however, be no difficulty in obtaining accurate and satisfactory results with the small centrifuge and bottles, and this may also in this respect prove a valuable adjunct to any pathological or physiological laboratory where analyses of human or cow's milk are occasionally called for. The practitioner will likewise find it useful in making analyses of such milk in the study of special cases and for hygienic-economical examinations.

The interested reader will find a full discussion of the Babcock test and of the general subject of milk analysis in a work recently published by Professor E. H. Farrington, of this university, in conjunction with the writer.††

††Testing Milk and its Products. Mendota Book Co., Madison, Wis., Fourth Edition, 1899.

F. W. WOLL.

Chemist to Wisconsin Agricultural Experiment Station, Madison, Wis., December, 1898.

Mr. Charles J. Chamberlain will begin a series of articles on Botanical Micro-technique in an early number of the 1899 Journal.

Laboratory Methods in Bacteriology.

DR. F. G. NOVY.

IV.—The Staining of Bacteria in Sections.

In order to ascertain the presence and especially the distribution of bacteria within the tissues and organs, it is necessary that small portions of the latter be hardened, then cut into sections and stained by appropriate methods.

As a rule, the tissue to be hardened should be cut up into small pieces, which should not be more than a quarter of an inch in thickness. It is always advisable to place the pieces of tissue on a piece of filter paper, or on some absorbent cotton. The liquid thus has free access to all parts of the tissue. The fixing and hardening of tissue which is to be stained for bacteria is usually done in alcohol, mercuric chloride, or in a formaldehyde solution. The details for fixing and hardening of tissues have been clearly stated by Dr. Huber in the March number of the Journal, and for that reason will be omitted in this connection.

It will be seen that, no matter what solution is used for fixing, eventually the tissues are placed in absolute alcohol. When thoroughly dehydrated, the material is now ready for cutting direct or for imbedding and subsequent cutting. The alcohol-hardened tissue may be cut direct, or may be softened by soaking in water and then frozen and sectioned. It is preferable, however, to imbed the tissue in paraffin or in celloidin, in which case thinner and better sections may be obtained.

The paraffin method is easy of execution and is to be recommended for the preparation of sections which are to be stained for bacteria.

Inasmuch as Dr. Huber has given extended and explicit directions for imbedding in paraffin, the reader will do well to refer to his paper in the April number of this journal (page 70). The material, once imbedded in paraffin, may be preserved in this condition indefinitely. Many bacteria, especially the leprosy and tubercle bacilli, lose their characteristic staining properties when the tissues which contain these organisms are preserved in alcohol. This can be obviated by keeping the material in paraffin.

The details for cutting paraffin sections and for affixing these on cover-slips are also given in Dr. Huber's papers (pp. 85, 103). After the removal of the paraffin from the sections, by means of xylol, they are ready to be stained.

The beginner will do well to stain sections of the kidney, liver, lungs, or spleen of a rabbit or guinea-pig which has died of anthrax. This material will serve to

familiarize him with the method of simple staining and with Gram's double staining of bacteria. The concentration of the dye, the time of exposure, and the temperature of the liquid are important factors which must not be lost sight of by the operator. The concentration of the acid or alcohol employed in the decoloration and the length of time that these are allowed to act on the stained section likewise affect the result. In the event of failure, the beginner should ascertain by systematic trial which of the factors is the one at fault. Success in staining sections requires an intelligent perseverance in and a study of the method employed.

SIMPLE STAINING.

The section, after treatment with xylol and alcohol, is transferred to water and then to dilute fuchsin or gentian violet stain. Carbolic fuchsin may be used to advantage. The section is allowed to remain in the dye from five to fifteen minutes. It is then washed for two or three minutes in water in order to remove the excess of dye; after which it is placed in very dilute acetic acid (1 cc. of glacial acetic to 1,000 cc. of water) for one-half to one minute. The treatment with acetic acid is not always necessary and should be avoided if possible. The section is now placed in strong alcohol for one-half to one minute and is then transferred to clean water.

It is then transferred to a slide and examined with a one-sixth or one-eighth inch objective. This examination is made in order to acquaint oneself with the condition of the specimen. The bacteria should be deeply stained and should be differentiated as much as possible from the surrounding tissue. If they are feebly stained, it is unnecessary to proceed with the method. If the tissue is still deeply stained, thus masking the bacteria, it should be again subjected to decoloration with acetic water and alcohol and reexamined.

When the section shows the proper degree of differentiation it should be placed in absolute alcohol for a few seconds in order to thoroughly dehydrate it. Inasmuch as this treatment with alcohol removes additional dye, it is well to stop the decoloring process, as given above, when the specimen is still slightly overstained. The treatment with alcohol, when dehydrating, will remove the slight excess of stain, and thus complete the differentiation.

The section is then placed in oil of cloves or organum for some minutes, after which it is transferred to xylol and then placed on a clean slide. The excess of xylol is removed by the application of a piece of filter paper. A drop of Canada

balsam is now applied and a clean cover-glass is placed in position. Gentle pressure or slight warming will cause the balsam to spread out evenly.

Oil of cloves can be used to advantage in the clearing up of sections. It dissolves some of the stain, and thus assists in the differentiation. This is especially true when it is used in Gram's method. All trace of the oil must be removed from the section by washing in xylol. Some stains, like methylene blue, are readily dissolved by the essential oils and in such instances the oil can be omitted. The dehydrated section in that case is placed direct in xylol. The process of simple staining as given is applicable to nearly all bacteria. It must, therefore, be resorted to whenever the organism does not take the Gram's stain.

The several steps in the method can be summarized thus:

Simple stain:

Dilute anilin dye, 5 to 15 minutes.

Water, 2 to 3 minutes.

Acetic water, 1-2 to 1 minute.

Strong alcohol, 1-2 to 1 minute.

Water (and examine).

Absolute alcohol, few seconds.

Oil of cloves or cedar.

Xylol.

Canada Balsam.

GRAM'S METHOD.

This method of double staining bacteria is easy of execution, and, when properly carried out, it will give clean, beautifully stained preparations. Unfortunately all pathogenic bacteria cannot be stained by this process.

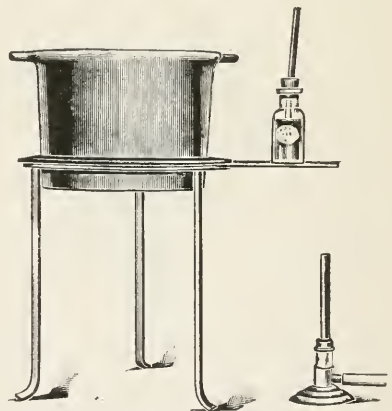

Fresh solutions of anilin water gentian violet and of iodine are prepared according to the directions given in the third paper of this series. The stain may be slightly warmed on the iron plate, but this is not necessary. Care must be taken not to stain too long, since in that

case it is extremely difficult to secure the proper decoloration. Rapid staining in a strong dye is preferable to slow, prolonged staining in a weak dye.

The section is placed in the stain for from ten to fifteen minutes. It is then washed in water to remove the excess of dye. The formation of unsightly deposits on subsequent contact with iodine is thus avoided. The section is then placed in the solution of iodine for five minutes. It is now transferred to absolute alcohol, in which it is gently moved about till most of the stain is removed. The section should not be wholly decolorated, but should still show a distinct violet color.

It is now placed in very dilute eosin for about twenty or thirty seconds. Overstaining with eosin will impart to the tissue a deep red color, which will thus make an unfavorable contrast for the violet colored organism. It is preferable to stain with eosin so that the tissue has a light pink color.

The section is transferred from eosin to absolute alcohol for one or two minutes. When thoroughly dehydrated it should be placed in oil of cloves and should be allowed to remain in this oil till all the violet color has been taken out of the section. The sections may remain in the oil for some hours, or even over night. The oil of cloves will decolor the section perfectly and will not affect the colored bacteria. The section is then passed through xylol, transferred to a slide and mounted in Canada balsam. The deep violet organism should stand out in bold relief against a light pink background.

The following summary will show the several steps in the method:

Anilin-water gentian violet, 10 to 15 minutes.

Water.

Iodine solution, 5 minutes.

Water.

Absolute alcohol, 5 to 10 minutes.

Water.

Very dilute eosin, 1-4 to 1-2 minute.

Water.

Absolute alcohol, 1-2 minute.

Oil of cloves, till decolorated.

Xylol.

Canada balsam.

LEPROSY AND TUBERCLE BACILLI.

These two organisms can be demonstrated in tissues by Gram's method. They can, moreover, be stained by a special method similar to that already described in connection with the detection of the tubercle bacillus. This method as applied to sections is as follows:

The section is floated on cold, fresh, carbolic fuchsin over night, or for about thirty minutes on the stain, which has

been warmed to about 40 degrees C. It should be remembered that the more deeply the section is stained, the more difficult it will be to properly decolor it.

The section is then transferred to water in order to remove the excess of the dye. It is then placed in sixty per cent. alcohol for one to two minutes, and then into Ebner's solution for about one-half minute, after which it is returned to the sixty per cent. alcohol for another minute or two, or until it is almost wholly decolorated. A light pink color of the section will be displaced on subsequent staining with methylene blue.

The almost decolorated section is placed in Loeffler's methylene blue for one half minute, after which it is washed in water. It is then placed in absolute alcohol for about twenty seconds in order to dehydrate. A longer exposure to alcohol will remove the blue stain. The section is then transferred to xylol for some minutes, after which it can be mounted in Canada balsam. A properly stained section will show the deep red bacilli on a light blue background.

Ebner's solution is ordinarily used for decalcifying purposes. The acid and alcohol present make it very useful for decolorizing sections, and it is to be preferred to the common method of treatment with nitric or sulphuric acids. It is prepared according to the formula:

Sodium Chloride	0.5
Hydrochloric acid	0.5
Distilled water	30
Alcohol	100

The leprosy and tubercle bacilli will give beautiful stains by this method when fresh tissues are employed. The preservation of the tissue in alcohol seems to destroy the capacity of these organisms to stain by this method. This is probably due to the removal or alteration of the fat which is present in these bacilli. The protoplasm of the organisms is, however, unchanged and consequently they can be stained by Gram's method when the other process fails. It is advisable to preserve leprosy and tubercular tissue in paraffin rather than in alcohol.

The special method just described can be summarized as follows:

Carbolic fuchsin, warm, 15 to 30 minutes.

Water.

Sixty per cent. alcohol, 1-2 minute.

Ebner's solution, 1-2 minute.

Sixty per cent. alcohol, 1-2 minute.

Loeffler's methylene blue, 1-2 minute.

Water.

Absolute alcohol, 20 seconds.

Xylol.

Canada balsam.

University of Michigan.

(To be continued.)

Journal of Applied Microscopy.

Issued Monthly from the Publication Department
of the Bausch & Lomb Optical Co.,
Rochester, N. Y.

L. B. ELLIOTT, EDITOR.

Address all communications to
PUBLICATION DEPARTMENT,
BAUSCH & LOMB OPTICAL CO.,
ROCHESTER, N. Y.

One Dollar per Year. To Foreign Countries, \$1.25
per Year.

Entered at the Post-office, Rochester, N. Y., as second-class matter.

DECEMBER, 1898.

EDITORIAL.

The completion of the first year of publication of the Journal of Applied Microscopy calls to mind the promises which we made in our initial number, and the manner in which these promises have been fulfilled during the year. When the publication of the Journal by the Publication Department of the Bausch & Lomb Optical Co. was first suggested, it was seriously questioned by many whether it was possible for a commercial institution to carry on the publication of a journal dealing with same subjects in which that institution was commercially interested without having the matter published in the reading pages tainted with partiality and restricted by business considerations. We promised our readers that such would not be the case, and submit Volume 1 as evidence of our good faith. The Journal is conducted purely as a business enterprise, is self-supporting, and appeals to the scientific public on its own merits.

We promised that the Journal should be expanded and improved as rapidly as the support given it would permit. We will begin Volume 2 with a larger number of reading pages, and a number of typographical improvements which will make the Journal more readable and present a better appearance. We promised that the Journal should be a record of new apparatus and improvements in apparatus as made in the laboratories in actual work. The fulfillment of this promise has of course depended largely upon contributions made by those engaged in laboratory work, and, while not as exhaustive as we hope these contributions will be during the

coming year, we have nevertheless published over thirty original papers dealing with this branch of applied microscopy; and we believe we are justified in saying that no other publication in the English language has ever in one year brought together as many papers upon microscopical technique or as many accurate descriptions of methods. The advantage of this concentration of information bearing upon laboratory work can best be appreciated by those who have heretofore been obliged to hunt through the files of society and institution publications and of other journals mainly devoted to other subjects for the desired information. It is also a fact that the existence of a suitable medium for the publication of practical papers has led many to write the results of their experience who would otherwise not have done so, and science is thereby to that extent the gainer.

The department of reviews and abstracts of microscopical literature published in various languages is now well established, and the department of Current Botanical Literature, conducted by Mr. C. J. Chamberlain of the University of Chicago, and of Animal Biology, by Miss Agnes M. Claypole of Cornell University, speak for themselves. We will soon have a similar department devoted to bacteriological literature, and in addition a department for the publication of abstracts not included in either of these three departments, so that during the coming year we shall cover the field of literature on microscopical subjects fairly well. Although a monthly publication cannot lay claim to much value as a news bearer, yet we have received many favorable comments upon the maintaining of the department of News and Notes in the Journal, and it will continue.

During the past year the Journal has made its way into every state and territory in the Union, and into almost every country in the world in which scientific work is done, the result being that its present circulation is 15,000 copies per month. Such being the case, we are able to offer our contributors during the coming year the advantage of placing their work before a very large audience of representative scientific men and institutions. As publishers we have done our part in establishing a journal for microscopical science, and in extending our thanks to those who have co-operated during the past year in making it a representative American publication, we trust that during the coming year we may be still further aided by all whose work lies within the field covered by the Journal in making it still more representative and still more successful.

Current Botanical Literature.

CHARLES J. CHAMBERLAIN.

Books for review and separates of papers on botanical subjects should be sent to C. J. Chamberlain, University of Chicago, Chicago, Ill.

REVIEWS.

Elmore, C. J. Some results from the study of *Allium*. Bot. Gaz. 26:277-278, 1898.

The reported polyembryony of *Allium tricoccum*, resulting from the development of embryos from antipodal cells, suggested the investigation of this and other species of the genus. Mr. Elmore's conclusions, which are supported by very strong evidence, indicate that in *Allium tricoccum*, polyembryony, if it occurs at all, is very rare. In seventy-five embryosacs at the fertilization period only sixteen contained antipodals which could be recognized, and even these appeared shriveled and dead. Twenty-six embryos were examined, all of which had developed in the normal manner from the egg cell.

A. cernuum gave about the same results. Out of ninety-five embryosacs at the fertilization period only twenty-nine showed antipodals, and these were small and apparently about to disappear. All the embryos examined in this species were normal in number and position.

In *A. canadense* nearly every preparation showed that the nucellus had died long before fertilization was possible, and later in the season it was found that only six embryos had developed from an half-acre patch where there had been thousands of blossoms.

These results show that the development of embryos from antipodal cells in these species is hardly to be expected unless it occurs in rare individual cases as a monstrosity. C. J. C.

Ritter, C. Haertung von Blut, Sputum, etc., auf Objectträgern. Zeitschrift f. wiss. Mik. 15: 159-161, 1898.

Dr. Ritter believes that in making permanent mounts of blood, serum, sputum, etc., and also of Bacteria, it is better to conduct the operations upon the slide than upon the cover glass, since the slide is less sensitive and is more easily handled. The slides, smeared with the material, are placed on a dish and formalin or osmic acid is poured on the bottom of the dish, which is then covered. Since the killing and hardening are accomplished by the fumes, the slides should be propped up so as not to touch the liquid. After the hardening, the staining may be done, either with or without a previous washing in water.

C. J. C.

Nawaschin, S. Ueber das Verhalten des Pollenschlauches bei der Ulme. Bull. d. l' Acad. Imper. d. Sci. St. Petersburg, 8:345, 1898.

Morphologists have been interested in the subject of chalazogamy since Treub's

work upon *Casuarina*. Miss Benson reported this condition for *Alnus*, *Corylus*, *Betula*, and *Carpinus*. Nawaschin found that in *Juglans regia* the pollen tube grows through the tissue of the ovule instead of passing through the micropyle, but the case was not one of true chalazogamy. In the present paper Nawaschin reports that in *Ulmus pedunculata* and *U. montana* the pollen tube may take almost any direction leading in general toward the egg. It may pass through the integuments to the micropyle, then behave in the usual way, or may pass through the chalaza as in a true chalazogam. Since no conductive tissue is developed and since the tube is so indefinite in its course, passing occasionally by the chalazal region, Nawaschin regards the Elms as some of the transition forms between chalazogams and porogams.

OTIS W. CALDWELL.

Chicago.

Zinger, N. Beitrage zur Kenntniss der weiblichen Blueten und Inflorescenzen bei Cannabineen. Flora, 85:189-253, 1898.

The writer finds that in the ovules of the Cannabineae the micropyle becomes closed by extended growth of the inner integument. The pollen tube grows through the two integuments, then down to the nucellus. Here several branches are formed, and finally one small branch penetrates to the embryosac.

OTIS W. CALDWELL.

Chicago.

Riddle, Lumina C. The embryology of *Alyssum*. Bot. Gaz. 26:314-324, 1898.

For many years text-book makers have used Hanstein's excellent figures and description of *Capsella* to illustrate the embryology of *Dictotyls*, but while the source has been the same, the text-book accounts have been various and confusing. It is probable that Hanstein's work was weak in a few details on account of the inferior methods which were in vogue when the article was written. Miss Riddle's description of *Alyssum*, a Crucifer closely related to *Capsella*, gives English reading students a careful and somewhat complete account of the embryology of a typical *Dictotyl*. A part of her summary is about as follows: The first division of the proembryo is transverse and the basal suspensor cell never divides afterward. The other cell divides into an intermediate cell, which contributes to both suspensor and embryo, and a terminal embryo cell. Octants are formed in both the terminal embryo cell and basal embryo cell. Periblem and plerome arise in the basal hemisphere of the terminal embryo cell; the cotyledons and stem tip from the terminal hemisphere. The calyptragen and root-cap are formed

from the basal hemisphere of the basal suspensor cell, while that part of the root-tip which forms the perilem of the radicle arises from the hemisphere lying next to the terminal embryo cells.

Chrom-acetic acid is recommended for killing and fixing. Aniline safranin alone or with gentian violet and orange G are recommended for staining. Iron-alum-haematoxylin was useful for bringing out early stages of the embryosac, but was not so good after the endosperm appeared.

With the exception of a few careless strokes in unimportant parts of figures 12, 37, and 39, the illustrations are excellent. C. J. C.

Spanjer, Otto. Botanische Untersuchungen ueber die Wasserapparate der Gafaesspflanze. Bot. Zeit. 56: 35-81, 1898.

In this paper the author presents the results of extensive investigations in the morphology and physiology of hydathodes, a name introduced by Haberlandt to cover all water secreting apparatus in plants, including water stomata, glandular hairs, and all epidermal outgrowths with their subepidermal apparatus, comprising the epithem or modified parenchyma lying immediately below the external secretory organ, the epithem sheath surrounding and inclosing it and constituting the termination of the conducting bundle sheath, and the tracheids terminating the bundles in the laminal teeth. The author finds that the tracheids end, not blindly against the epithem cells, but free in the intercellular spaces of the epithem cells. He further demonstrates, contrary to the view of Haberlandt, that the epithem cells do not function as water secreting glands, and do not further the extrusion of water from the leaves, but that such extrusion is due wholly to hydrostatic pressure, or, as it is commonly called, "root pressure." He demonstrates the morphological identity of water stomata and air stomata, their difference being functional rather than structural. Great variations in the amount and arrangement of the subepidermal hydathode apparatus were found. In view of Koorder's recent account of water secreting glands, in the unopened calyx leaves of certain tropical plants, the problem of water secreting glands as distinguished from water stomata, strictly speaking, may be regarded as open for further investigation, and not closed in the negative, as the present author is inclined to think.

H. F. ROBERTS.

Chicago.

Jones, Herbert L. A new species of Pyrenomyces parasitic on an alga. Oberlin College Lab. Bull. No. 9, 1898.

Pyrenomyces on algae are almost unknown, a Sphaeria-like Pyrenomyces

on Ascophyllum and a Sphaerella on Laminaria being the only ones described. The following species on Chondrus crispus adds a third to the list.

Sphaerella chondri, n. sp. Perithecia black, sunk in the fronds, separate, or two or three close together. Asci oblong 75x80x11-13 μ , spores filling the entire ascus. Spores biseriolate, elongated, elliptical, uniseptate, hyaline, upper cell more acute, 33-34x5-6 μ . On Chondrus crispus, Nahant, Mass., November and December.

This short note was the last piece of botanical work done by the late Professor Jones, whose untimely death is deeply regretted by botanists and mourned by his pupils, who lost not only a teacher but a friend. C. J. C.

Johnson, D. S. On the development of the leaf and sporocarp in *Marsilea quadrifolia*. Ann. Bot. 12: 119-145, 1898.

The leaf arises from a two-sided apical cell which cuts off segments towards and away from the apex of the stem. Each segment is then divided into five "sections" and an ultimate marginal cell by means of five walls inclined alternately toward the dorsal and ventral sides of the leaf. In the pinnae the formation of these walls is continued in certain segments, and rapid division in a direction parallel to the leaf axis gives breadth to the lamina.

The sporocarp develops from an apical cell arising from a marginal cell of the inner side of a young leaf. In the seventeen or eighteen segments producing the capsule, the succession of radial anticlines is such as to bring the ultimate marginal cell nearer to the ventral surface. During the growth of the capsule each marginal cell produces a series of five rows of cells which become infolded so as to lie in the "soral canals." Of each series of five rows, the middle row produces the macrosporangia, the two flanking rows the microsporangia and the two outer rows a true indusium. The sporangia develop after the Septosporangiate type.

The sporocarp is the homologue of a petiole of a sterile leaf, and the capsule is the equivalent of the swollen end of a petiole whose marginal cells form sporangia instead of laminae.

W. D. MERRELL.

Chicago.

Kofoid, C. A. Plankton studies. II. On *Pleodorina illinoisensis*, a new species from the plankton of the Illinois river.

This work adds a second species to the genus *Pleodorina* discovered by Shaw at Palo Alto, California, in 1893. Kofoid thinks that *P. californica*, described by Shaw, is probably quite widely distributed, the new species, *Pleodorina illinoisensis*, was found associated with *Eudorina elegans* and *Pandorina morum*. The

striking feature in the new species, as in *P. californica*, is the presence of two distinct types of cells in the colony. Four vegetative cells constitute the anterior polar circle and are directed forward in locomotion. The rest of the cells are gonidial. The paper is illustrated by a plate showing the mature form and several stages in development. The following description will enable any one to recognize the species.

Pleodorina illinoisensis, n. sp.—Number of cells in a colony usually thirty-two, rarely sixteen or sixty-four. Dimensions of colony range from $46 \times 33 \mu$ to $200 \times 175 \mu$. Vegetative cells always four in number. Gonidial cells approximately one and one-half times the diameter of the vegetative cells. Known habitat, submerged lands along the Illinois river. Types deposited in the collections of the Illinois State Laboratory of Natural History and in the United States National Museum.

C. J. C.

Klebs, Georg. Zur Physiologie der Fortpflanzung einiger Pilze. 8. *Sporodinia grandis*, noting particularly what conditions induce growth of the sexual or asexual organs.

Transpiration, induced by whatsoever cause, is the most common factor causing sex organs. The food, however, must be appropriate, i. e., must contain proper carbohydrates. Parthenogenesis always resulted on reducing the air pressure to about 50 mm. of mercury, while below 15 mm. the plant was sterile. A trace of acid salt favors zygote formation, while acids or normal salts restrict it. Sporangia, in general, appear under conditions which prohibit zygote formation. This explodes the prevalent idea. Owing to the accelerating influence of light on sporangium formation, pure cultures of sporangia could be obtained by placing covered beakers, containing cultures, in the sunlight. The effect of humidity was counteracted by the light and sporangia resulted, while purity was promoted by the cover.

F. L. STEVENS.

Chicago.

Belajeff, Wl. Die verwandschaftlichen Beziehungen zwischen den Phanerogamen und den Cryptogamen in Lichte der neuesten Forschungen. *Biol. Centralbl.* 18: 209-218, 1898.

This paper presents a critical review of previous work upon the gametophyte structures of Bryophytes, Pteridophytes, Gymnosperms, and Angiosperms. Homologies are traced in a masterly manner. The female prothallium shows a gradual transition from Cryptogams to Phanerogams, but the author does not attempt to interpret the puzzling structures of the Angiosperm embryo-sac. The male prothallium furnishes a still more gradual transition from Cryptogams to Phanerogams. The discovery of spermatozoids in Gymnosperms is another proof

of the relationship between the vascular Cryptogams and Cycads.

C. J. C.

RECENT LITERATURE.

Cavara, F. Intorno ad alcune strutture nucleari Atti dell' Instituto botanico della. R. Università di Pavia. II, 5: 1-49, 1898.

Ikeno, S. Untersuchungen ueber die Entwicklung der Geschlechtsorgane und den Vorgang der Befruchtung bei *Cycas revoluta*. *Jahrb. f. wiss. Bot.* 32: 557-603, 1898.

Klebahn, H. Ueber den gegenwaertigen Stande der Biologie der Rostpilze. *Bot. Zeit.* 56: 145-158, 1898.

Luestner, G. Beitrage zur Biologie der Sporen. *Bot. Zeit.* 56: 198, 1898.

Mitrophanow, P. Beobachtungen ueber die Diatomen. *Flora.* 85: 293-314, 1898.

Nathansohn, A. Beitrage zur Kenntniss des Wachstums der trachealen Elemente. *Jahrb. f. wiss. Bot.* 32: 671-686, 1898.

Osterwalder, Adolf. Beitrage zur Embryologie von *Aconitum napellus*. *Flora.* 85: 254-292, 1898.

Pammel, L. H. Comparative anatomy of the corn caryopsis. *Rep. of Iowa Acad. Sci.* 5: (No. 10, pp. 1-5), 1898.

Wille, Dr. N. Beitrage zur physiologischen Anatomie der Laminariaceen.

Animal Biology—Current Literature.

Separates of papers and books on animal biology should be sent for review to Agnes M. Claypole, Sage College, Ithaca, N. Y.

Jander, R. Chromsalpetersaure als Pigment Zerstuerendes Mittel. *Zeitschrift f. Wiss. Microscop.*, 15: 1898.

The author has been using the means he describes for removing pigment from animal tissues since 1891, and always with certainly good results. It is a process already known as a means for hardening and was first proposed by Fol:

Chromic acid 1 per cent. sol.	70 parts
Saltpeter	3 parts
Water	200 parts

It has long been known that black or brown pigment could be destroyed by chromic acid and potassium bichromate, but since the process required several weeks for completion it was not generally applicable. The chromic nitric acid, on the contrary, destroys pigment very quickly, so that the tissue is neither made brittle or otherwise changes. Tissues were first fixed in the best way to preserve their structure, and then washed; when the pieces of tissue were easily permeable they were carried from strong alcohol back to water, and then put in the decolorizing mixture for twelve to twenty-four to forty-eight hours, and the pigment was completely removed.

Large pieces of tissue, more difficult of penetration, which can be sectioned, were cut first and then decolorized. The only difficulty in this process is that sections fixed to the slide with water are apt to be loosened, and thin albumen fixative is hence necessary; with that

fixative, however, very few sections are lost. If it is not necessary to preserve the finest histological details, the tissue can be killed and decolorized at the same time. The only precaution necessary to make the wash-out easy and complete, is to keep the tissue in the dark during the decolorizing and washing processes. Among the many kinds of tissues used were: mantle of lamellibranchs, leeches, arthropod eyes, skin of fishes, frogs and vertebrates.

A. M. C.

Tellyesniczky, K. Ueber die Fixirungs Flussigkeiten. *Archiv f. Mikros. Anat.*, 52: 1898.

A short history of hardeners is followed by a table of the most used fixers, and then the author considers the practical application of these fluids. They were tried especially on the testis of the salamander, since the cells of this tissue show details remarkably well and the structures are well known. No single mixture was found that completely preserved the cells, but two groups were made according to results. One includes osmic acid and potassium bichromate, which preserve the plasma contents of the cell most excellently. Another included the simple liquid, alcohol, chromic acid, nitric acid, picric acid, sublimate and formol. These destroy the plasma wholly or preserve it in a more or less mangled condition. Nuclear preservation is, however, very good. Formol is most destructive, as it changes both nucleus and cytoplasm. A two to three per cent. solution of nitric acid is the best of these for preserving both sets of characters. Acetic acid was found to preserve the cell substance most clearly, and by combining this with osmic acid or potassium bichromate the best results were obtained. These were used in the following proportions:

Potassium bichromate	3 grams
Acetic Acid	5 cubic centimeters
Water	100 cubic centimeters

Small pieces were left in the liquid one to two days, and larger for longer. They were washed out in water and alcohols of increasing strengths, beginning with fifteen per cent. Of the well known liquids, Flemming's and Lenker's were satisfactory, Von Rath's Picro-osmic-acetic and Picro-sublimate-acetic were less satisfactory.

A. M. C.

Auburtin, G. Beitrag zur Technik des Auswaslebens von Celloidinschnitten. *Anat. Anz.*, 13: 1897.

The author gives a description of a method well known in some places, but not generally used, for securing collodion sections to the slide or to each other.

Since it seems but locally used and is so successful, it will be presented in full in this abstract. After the sections are cut, according to the author, in seventy

per cent. alcohol, they are arranged on a slide or shallow dish or left on the knife, and all possible alcohol removed with tissue or thin paper, care being taken not to rub away the sections with the paper. The absolute alcohol is dripped on so as to push the sections together, not spread them, and this allowed to stay for half a minute or so. After taking up the absolute alcohol, a mixture of ether and alcohol is dropped on and if enough is used to cover the whole slide or the surface on which the sections are placed, on allowing it to evaporate, the sections will be found firmly cemented together on the slide. If a slide has been used the process is complete; if not, the membrane formed and containing the sections can be carefully removed from knife or dish and fastened to the slide with a thin layer of collodion. This process has been in use for several years in the histological laboratories of Cornell University, excepting that no absolute alcohol is used, ether-alcohol being used alone, and also that cutting is done in oil, either castor-xylene or castor thyme.

A. M. C.

Garcia, R. Un procede nouveau et rapide de ovulele coloration du Sang (Cornica medie quir de la Havana, 23: No. 23).

Red blood corpuscles in a normal condition take the acid stains as eosin safranin, etc., and the leucocytes and bacteria which are in the blood the basic stains as fuchsin, methyl blue, etc., and the protoplasmic granules of the leucocytes the neutral dyes. A very simple method of accomplishing this result is as follows: A small drop of blood and a drop of sterile bouillon are placed on a cover, with a sterile platinum needle. These drops are mixed and spread evenly on the cover. The preparation is dried by placing the cover on a slide and passing it through the flame of a lamp or gas jet, the slide forming a protection from too much heat; less than a minute usually suffices. Then the preparation is stained in eosin, first followed by methylen blue (plain solutions) washed in water and mounted in balsam, the whole process taking five minutes or so. The author thinks it best to use eosin, first following it with the methylin blue. The advantage of the bouillon as a dilutant is in its being free from crystals.

A. M. C.

Pappenheim, A. Ueber Eutwicklung und Ausbildung der Erythroblasten (Virchow's Arch. 145: 1898).

In an earlier paper the relations between megaloblasts and normoblasts were considered, and in reference to the great diagnostic and prognostic significance of megaloblasts, a new investigation seemed needed into the relations of these cells with anaemia. The most

obtainable material for investigating such nucleated red blood cells were anaemic blood, bone marrow, and blood of vertebrate embryos. It was deemed wise to include in this study the blood of some of the lower animals in order to bring embryonic conditions into their true relations. Amphibian blood was chosen for this purpose and observations carried out on uncolored preparations, especially to clearly recognize the artificial products caused by staining processes.

In some megaloblasts the nuclei appear as completely structureless white drops, and are called red ematous nuclei; they are not artefacts since they can be found in quickly made, thoroughly dried coverglass preparations; also if the blood is fixed in sublimate as it is shed. The best fixer of hemaglobin and nuclear substance, in amphibian blood at least, was shown to be a mixture of concentrated sublimate and freshly prepared two per cent. osmic acid in equal parts. After treatment in alcohol and ether and flaming, the preparations were dried in a dryer and held for a moment over an ammonia flask; then washed in the fixing fluid, and finally in very weak pyrogallie acid, and last in distilled water.

Colored preparations were made from fresh unfixed blood, and after the fixing of dried blood. The following colors were finally used: Erlich's triple glycerine mixture (containing Aurantia, Eosin), Spuler's orange-eosin, aurantia-S. fuchsin, corallin benzo-purpurin, aurantia-methyl orange, congo red. Several different neutral mixtures were tried, Erlich's triacid and the gold-orange or bergonzini. This mixture acted so that the red alone was only present as a trace compared with the orange. Many interesting features were made out in tissues examined, but the methods are of greatest interest.

A. M. C.

Lewis, Margaret. Studies on the Central and Peripheral Nervous System of the Polychaete Annelide. Proc. Am. Acad. Arts and Sci., 33: No. 14.

A paper with eight plates by Margaret Lewis gives the results of her investigations upon the nervous systems of *Clymene prolecta*, and *Axiotea torgnata*.

Aside from the general morphology of these Maldanid worms, she has paid special attention to Leydig's fibers, the centrosome of the ganglion cell, and the sense organs.

The term "Leydig's fiber" is used to designate the annelidan structure known under the different names of Neurochord, giant fiber, central canal, and neural canal.

She finds confirmation of the views that Leydig's fibers in annelids are true nerve fibers; that the sheath of these fibers is comparable to the medullary sheath of

nerve fibers in vertebrates; that the contents are comparable to the axis cylinder; and hence, that the distinction made between the nerve fibers of vertebrates and invertebrates cannot be maintained.

In the Maldanidae these fibers do not function in any way as an organ of support. They are neither homologous nor analogous to the chorda dorsalis of vertebrates.

They result from the union of direct processes of giant ganglion cells. In the forms studied these cells appear in the sub-oesophageal ganglion and are found scattered along the lateral and ventral portions of the ventral nerve cord without indicating metamerism or symmetry. In the sub-oesophageal ganglion, however, they show an approach to symmetry.

The substance of the Leydig's fiber is uniform throughout, and does not represent a bundle of nerve fibrillae; further, the fiber does not show any indication of being a degenerate structure. The relation of the process of one giant cell with that of another appears to be one of direct continuity, not of simple contiguity. If Leydig's fibers are true nerve fibers, as maintained, they stand in their relation to ganglionic cells, in strong opposition to the neuron theory of Wald-eyer, Edinger, von Lenhossek, and others. The giant cells giving rise to these fibers possess a nucleus which is always eccentric in position, and a centrosome and sphere which are more central in position.

The division of nerve cells was observed in these worms and the presence of the centrosome is taken as an argument that it has some function other than that of cell division.

A note in this connection by E. L. Mark calls attention to the importance of the question whether a genetic connection may be established between the so-called centrosome which exists during cell division.

The centrosome in these ganglion cells is evidently a center of mechanical activity, as shown by the eccentric position of the nucleus, the frequently observed flattening of the nuclear membrane on the side toward the centrosome, the concentric arrangement of the protoplasm around it and by the radiations extending out from it.

The presence of a centrosome in ganglionic cells is an argument for its being a permanent cell organ. Some of the giant cells show two centrosomes and spheres without any evidence of approaching nuclear division.

Parts of the peripheral nervous system of both worms terminate in multicellular sense organs, occurring abundantly throughout the integument in certain

regions of the body. These sense organs are collected into definite rows, groups, and zones. The individual sense cells making up these compound organs are bipolar nerve cells with peripheral prolongations which terminate in a single sensory hair. The prolongation of the deep end has not been completely followed out, but as far as traced is unbranched, and represents a true nerve fibril.

E. M. BRACE.

Abbreviations used: Zeitschr. f. Mikroskop u. f. Mikroskop, Techn.=Zeitschrift fuer Mikroskopie und fuer Mikroskopische Technik. Archiv. f. Mikros. Anat.=Archive fuer mikroskopische Anatomie. Anat. Anz.=Anatomischer Anzeiger.

ABSTRACTS.

Adulterations of Buckwheat Flour Sold in the Lawrence Market.

Microscopic tests of the purity of commercial buckwheat flour were made by M. A. Barber. Of the seven samples examined, four were found to be adulterated, so that the proportion of buckwheat present was about two-thirds, in one case only one-half.

Kaffir corn flour and certain grades of shorts may be used as adulterants, but in the samples tested some grade of wheat starch had evidently been used. Under the compound microscope, the granules of buckwheat flour are seen to be of about uniform size, irregular in outline, closely compacted, and the individual grains show few concentric lines.

In wheat starch obtained from shorts, the grains vary in form, and the large ones are much larger than any found in buckwheat. They are more regular in outline, are usually round, or elliptical, and have well marked concentric lines.

Buckwheat flour is probably improved by the addition of a certain proportion of other flour, but the price of the mixture should diminish in proportion to the amount of cheaper flour added.

E. M. BRACE.

Kansas University Quarterly, Vol. VII, No. 1, January, 1898. Series A.

The Preparation and Use in Class Demonstration of Certain Cryptogamic Plant Material.

Some methods for the preparation of cryptogamic material for class work are described by M. A. Barber, of Kansas University.

Sclerotia, which may be found in rotten wood, or on the ground under old logs, was used for obtaining plasmodia for the study of the Myxomycetes. Pieces of the material put in a warm, moist place

usually develop plasmodia in a few hours, and the plasmodia may be fed with rotten wood and fleshy fungi. Small plasmodia, for the demonstration of protoplasmic currents, may be obtained by putting pieces of sclerotia in a hanging drop of water, or by placing in a large cover glass on a plasmodium, and transferring it to a moist cell after the plasmodium has run over it.

Swarm spores of Myxomycetes may be obtained by sowing spores in vials of water.

Drop cultures for the study of zoospores and early stages of some Algae were prepared by making incisions in a piece of cork, and fitting large cover glasses into the cuts in such a way that some of them would be wholly, others partly, submerged, when the cork was floated on water. When this apparatus was placed in a culture dish containing algae, zoospores will fasten to the cover glasses, and may then be mounted over moist cells for a study. The Saprolegnieae are especially favorable for the study of zoospores, and may also be used to show the growth of hyphae and the formation of oogonia, zoospores, and antheridia. Material may be obtained by throwing insects, spiders, or other organic matter into pond water. A supply of water plants will keep such cultures pure.

The method of distribution of spores through hygroscopic action in mosses, ferns, equisetums, etc., may be shown to large classes by means of the stereopticon in the following way: thick sections made through the fruiting parts are mounted in water on a slide without a cover and the surplus water is drawn off. When this is placed in the apparatus for projecting objects on the screen, the heat from the light dries the preparation rapidly, and the movements of the annuli and elaters are shown on the screen.

E. M. BRACE.

Kansas University Quarterly, Vol. VII, No. 2, April, 1898. Series A.

Refractive Index and Alcohol-Solvent Power of a Number of Clearing and Mounting Media.

The results of some experiments on the refractive and clearing powers of different reagents are given by C. A. McClung, of Kansas University.

In ascertaining the clearing value of substances, the method of testing the strength of alcohol that would dissolve in the reagent was found to be sufficiently accurate for practical purposes. The refractive index was determined by means of the Pulfrich refractometer.

The results show a series of clearing agents with refractive indices varying

from 1.44 to 1.60. The oil of cassia is cited as being of especial value. It has a refractive index of 1.601160, clears from 30 per cent. alcohol, and dries hard enough to make permanent mounts. Following is the table:

	Refractive Index.	Per cent. of Alcohol which substance will dissolve.
Linalool	1.45941	80%
Chloroform	1.4395	95%
Oil Eucalyptus	1.46090	90%
Linaloe	1.46090	85%
Oil Pettigrains	1.46090	90%
Oil Coriander	1.46288	85%
Oil Peppermint	1.46327	85%
Oil Cedar	1.46626	95%
Oil Pinus Sylvestris	1.46882	100%
Turpentine	1.46882	100%
Oil Lemon	1.47078	95%
Oil Eucalyptus glob	1.47077	90%
Oil Orange	1.47176	95%
Oil Oinus Picea	1.47274	100%
Oil Juniper Berries	1.47394	95%
Oil Pinus Pimlionis	1.47620	100%
Oil Citronella	1.47909	90%
Oil Origanum	1.47919	95%
Turpinoel	1.48005	75%
Oil Celery	1.48054	95%
Oil Nutmeg	1.48054	95%
Oil Origanum	1.48103	95%
Oil Caraway	1.48441	90%
Oil Ginger	1.48807	95%
Xylene	1.49348	95%
Benzene	1.49488	95%
Carvol	1.49505	85%
Oil Thyme	1.49638	95%
Oil Copaiva	1.49723	Immisc
Oil Cedarwood	1.50188	95%
Oil Cedarwood	1.50326	95%
Oil Cumin	1.50373	90%
Oil Sandalwood (E. In.)	1.50510	90%
Oil Calamus	1.50602	95%
Oil Sandalwood (W. In)	1.50820	80%
Oil Cedarwood	1.51533	95%
Xylene Balsam	1.52397	
Oil Sassafras	1.52724	95%
Oil Allspice	1.53062	85%
Oil Cloves	1.53171	80%
Oil Sweet Birch	1.53329	90%
Oil Cinnamon leaves	1.53535	85%
Safrol (sp. gr. 1.108)	1.53584	95%
Oil Fennel	1.53885	95%
Oil Cloves	1.53723	80%
Oil Mirbane	1.54982	95%
Oil Anise	1.55795	95%
Oil Anethol	1.55208	90%
Oil Anilin	1.58457	60%
Oil Cassia	1.60160	80%

E. M. BRACE.

The Microscope as Practically Applied to Fish Culture.

J. J. Stranahan. Read before the twenty-seventh annual meeting of the American Fisheries Society, 1898, Omaha, Neb.

The most important work of the microscope in fish culture is, doubtless, to determine the condition of eggs soon after they are taken so as to remedy early any errors of the spawn-taker which may exist, and thus save unnecessary loss.

In examining eggs under the microscope, I use a cell that holds a certain number of eggs, as for instance, in the case of the whitefish my cell holds twenty eggs in a row and five rows deep, making in round numbers 100 eggs, although eggs vary so much in size that this is not absolute.

The eggs which are impregnated, unimpregnated, and those with ruptured yolks are so easily detected, one from the other, that the cell may be moved under the microscope as fast as one can count.

It is the practice of the writer to examine whitefish and cisco eggs twenty-four hours after they are taken, when segmentation is at its most distinct period. The disc of the impregnated egg will then be found divided into some fifteen or twenty cells, and very distinct, under a half-inch objective. The disc of the unimpregnated egg will be an almost perfect hemisphere and will present a much clearer appearance than the impregnated one. The eggs with ruptured yolks will present a varied appearance. Generally the albumen will be in a layer at the bottom, the oil globules at the top and the disc, much distorted and out of all semblance of the normal, floating between the two. There is another class of valueless eggs, those containing no germinal disc at all, but they constitute a very small per cent., and, of course, no amount of care on the part of the spawn-taker could put life into these, they need not be taken into account at all.

Thus, it will be seen, the eggs at the station can be examined each day, each lot separately, and a record of the work of each and every spawn-taker kept, his errors corrected or the man discharged, and by going over the tables resulting from this work, when about to engage spawn-takers for a season, it can be seen at a glance which are the best men, weed out the poorer ones, and greatly improve the spawn-taking force.

About seventy-five spawn-takers are employed at the Put-in-Bay station each fall, and it will be apparent to the most casual observer that this plan of examining eggs must result in the securing of a much larger number of good eggs than would otherwise be the case.

The great advantage of the microscope

is that it can determine in twenty-four hours whether the eggs are good or not and apply the remedy, while without it, especially in the case of unimpregnated eggs, it is necessary to wait until the season is nearly over before knowing the result, and in the meantime millions, perhaps, of eggs are lost which should have been saved. The writer frequently uses the telegraph in calling delinquent spawn-takers to task, and believes that it has paid well on the investment.

Aside from examining the eggs to determine their quality, the microscope can be made of use almost daily while eggs and fry are in the house. Many little emergencies arise when it is desirable to make a closer examination of eggs or fry than can be made with the unaided eye, and it soon becomes a second nature to resort to the microscope.

To illustrate: at the Put-in-Bay station, one morning last April, it was discovered that the pike-perch eggs were so light in the jars that it was difficult to keep them from flowing out, although the water had been shut down to a considerable extent. The microscope revealed the fact that colonies of infusoria—mainly the species *Carchesium*, with a few *Vorticellae*—were so common that it was difficult to find an egg without one or more. The eggs were thoroughly feathered, thus breaking off the slender stems by which the infusoria were attached, when they worked as well as ever, and no harm was done further than that incident to the handling of this very tender egg. I will state, incidentally, that this phenomenon has never occurred before at the Put-in-Bay station or elsewhere, to my knowledge.

L. B. E.

Notes on Culture Media.

Dr. Erwin F. Smith gives the following list of culture media which he has found useful for the differentiation of species:

1. Uschinsky's solution.
2. Tubes of standard nutrient agar with the addition of 10, 20, and 30 per cent. of grape sugar.
3. The same with 10, 20, and 30 per cent. of cane sugar.
4. Nutrient starch jelly with and without various sugars, alcohols, etc.
5. Cylinders of cocoanut flesh in distilled water.
6. Cylinders of white or yellow turnips in distilled water.
7. Cylinders of carrot in distilled water.
8. Cylinders of white sugar beet in distilled water.
9. Potato cylinders standing in several cubic centimeters of distilled water (for prolonged growth).
10. The extension of tests with fermentation tubes to include, in addition to

grape, cane, and milk sugar, the following substances: fructose, galactose, maltose, dextrine, mannite, and glycerine.

These crude vegetable substances contain very different quantities and kinds of nutrient substances, and the variety offered enables one to determine the peculiarities of the germs, which, when once discovered, may be studied by more exact methods.

E. M. BRACE.

Proc. Am. Asso. Adv. Sci., Vol. xlvil, 1893.

Bacteriological and Chemical Studies of Sauer-kraut.

The fermentation of white cabbage to sauer-kraut is caused by *Bacterium brassicae* Lehm and Conrad—a close relative of *Bacterium coli*, according to Eugene Conrad. In addition, two species of yeasts were found, one closely related to *Saccharomyces cerevisiae*, the other to *S. minor*. The acid thus produced by the bacterium increases up to a certain point, and then remains constant. It produces aethylic lactic acid and the following gases, CO₂, H₂, and CH₄. The gases H₂ and CH₄ occur in greater quantity than CO₂. The yeasts furnish the alcohol necessary to form this acid. If cabbage is fermented with the yeast alone, a disagreeable butyric acid odor is produced. The yeasts counteract these injurious properties.

L. H. PAMMEL.

Archiv. f. Hyg. 24 : 56.

Rapid Hardening of Sputum.

C. Ritter recommends the following rapid drying and hardening of sputum and blood upon slides. A glass dish or tray on blocks to support slides was used, or a glass dish with glass supports on side for slides may be made. These may be used to hold as many slides as desired. The glass tray contains a small quantity of either osmic acid or formalin. The sputum is placed on the slide and then with face down is put on the bench. The dish is then covered. Hardening proceeds very rapidly, after which the specimen may be stained and mounted.

L. H. PAMMEL.

Zeitscher, f. Wissenssch. Mikroskopie 18 : 159-61 f. 1-2.

Different Gelatine Media and Bacteriological Water Analysis.

Korn states that the peptone-water-salt-gelatin is much better for the development of water bacteria than bouillon gelatin. More germs developed in the former than in the latter. Good development also occurred when salt was absent. The high percentage of salt in ordinary media, as well as grape sugar and glycerine, acted unfavorably on the

development of bacteria. These statements apply only to water bacteria. He recommends a 20 per cent. water-peptone-Koch-gelatin; a five per cent. gelatin may be used for testing filters. He also recommends the use of iron salts for the culture of pathogenic bacteria. He used among others a ten per cent. Liq. ferri alb.

L. H. PAMMEL.

Inaug. Diss. Königsberg, 1898.

Is the Bacterium Cell Nucleated?

Opinions differ among bacteriologists as to whether the bacterium cell is nucleated. Migula holds it is not, and in support of his position has reinvestigated Meyer's *Astasia asterospora*, Meyer having described a very small nucleus (Körnchen). Migula holds that these "Körnchen" are similar to those occurring in *Bacillus oxalaticus*, *B. cereus*, and *B. megaterium*. There may be a single one of these bodies in a cell or more than one. They originate from the peripheral protoplasm of the wall and in *Astasia* and other species never divide. They originate in all probability from small invisible granules that coalesce. A similar phenomenon occurs in the formation of spores. In *Astasia* he confirms the peculiar spore membrane which he has never observed in other bacteria. As to the peculiar arrangement of the flagella, the author was unable to confirm the results of Meyer's work. He calls the organism *Bacillus asterosporus*.

I. H. PAMMEL.

Flora 85: 141-150, f. 1-3.

NEWS AND NOTES.

Minor notes on technique, personals, news items, notices of meetings of societies, conventions, etc., will be received up to the tenth of the month preceding issue.

Yeast.

Yeast and *Spirogyra* are as indispensable to the botanist as the frog to the physiologist, and any new light upon their internal structure is eagerly welcomed by teachers who have occasion to use them in laboratory courses. During the past few years much has been learned regarding the nuclei of these organisms. It seems now that the presence of a nucleus has been demonstrated beyond question in most species of *Saccharomyces*. Many a teacher has tried to stain the nucleus of yeast cells for exhibition to his students, but in most cases, judging from the number of complaints one hears, the attempt has ended in failure. So explicit are the directions given in a recent paper* that it seems

worth while to reproduce them somewhat in detail and to state briefly the results obtained by their use.

The authors used *Saccharomyces cerevisiae* L. Hansen, *S. Ludwigii* Hansen, and *S. Octosporus* Beyerinck, together with several other species not identified. Cultures were made in sterilized and well aerated must of 12 degrees to 14 degrees Balling, in conical Erlenmeyer flasks, and kept in an incubator at 20 degrees C. The cells were fixed in Moeller's liquid (100 cubic centimeters of distilled water, one gram of iodide of potassium and iodine to saturation). The method of fixation is as follows: several drops of the solution are placed upon a slide, then with the aid of a platinum loop a small amount of yeast is mixed with the liquid and a drop of the mixture placed upon a cover glass and spread around evenly with the loop. The cover-glass must be perfectly clean and free from grease. The preparations are allowed to dry in the air, and at the exact moment at which the last of the liquid has evaporated from the cover glass, the latter is quickly immersed in a Petri dish containing Moeller's fluid, the cover of the dish replaced and the preparation left in the fixing agent at least twenty-four hours. It is very important that the cells do not become too dry in the air. At the expiration of the time for fixation, the preparations are passed successively through water, "one-third alcohol," 80 per cent. alcohol, and finally into 95 per cent. alcohol. In order to obtain a clear coloration the iodine must be thoroughly removed. This usually takes place in the 80 per cent. alcohol, but if it does not one may use a solution of iodide of potassium (1 to 3 parts to 100 of water) or ether. The preparations must remain at least two days in 95 per cent. of alcohol before being colored. They may then be stained at once or may be kept indefinitely in this grade of alcohol. Fixation must not be accompanied by passing the cover glass through the flame, as is often done with preparations of bacteria.

Staining may be done according to various bacteriological methods, but the best results are said to be obtained by using Heidenhain's iron-hematoxylin. The preparations are treated for four hours with a solution of 2-5 grams of ferric alum in 100 cubic centimeters of distilled water and then colored for twelve to eighteen hours in 0.5 grams of hematoxylin in 100 cubic centimeters of distilled water. When properly decolorized, the preparations now show the nucleus to be stained intensley black, while the cytoplasm remains colorless or has a faint violet tint.

The stained preparations may be mounted in 50 per cent. glycerine, but the

color is likely to fade after two or three months, though it may remain for a much longer time. For studying the preparations to the best advantage two millimeters apochromatic homogeneous immersion objectives and the appropriate compensating oculars are needed.

Employing this method, the authors have studied the nucleus and cytoplasm of yeast cells, the process of budding and the accompanying karyokinetic changes, and the formation of spores. The investigations were evidently carried on in the most careful manner, and the results obtained seem entirely trustworthy. Of the many conclusions arrived at, the following are the most important:

1. Every yeast cell in the quiescent state encloses a nucleus.

2. This nucleus consists of a membrane, caryoplasm, and nucleolus.

3. In well nourished yeast cells the cytoplasm has a typical reticulated structure and a nucleus as indicated above.

4. In the budding of *Saccharomyces Ludwigi*, the nucleus undergoes a very reduced indirect division. The spindle is plainly visible as well as the cell plate.

5. In *Saccharomyces cerevisiae* the division of the nucleus is made in the direct manner at the time of budding.

6. In this species at the same time the nucleolus divides into two in the mother cell in the neighborhood of the bud. One of the nucleoli then passes into the bud by the pedicel, which separates the bud from the mother cell.

7. In cells which are preparing to form spores two nuclei appear. These fuse and the resulting nucleus contains double the amount of nucleine found in an ordinary nucleus. Thus a fecundated egg results.

8. The new nucleus divides by a sort of very reduced kinesis, a spindle, fusorial plate, and cellular plate being evident.

9. A second division follows, accompanied by the same figures, though more reduced.

10. Thus, four nucleoli are produced. Around each of these and the contiguous cytoplasm a membrane forms and the nucleus of each spore is thus reconstituted.

The paper contains numerous valuable criticisms of the methods and results of Schmitz, Hansen, Dangeard, Moeller, and other students of the yeasts. The plates include more than two hundred figures.

CHARLES WRIGHT DODGE.

Recherches cytologiques sur la cellule de levure, par MM. Fr. A. Janssens et A. Leblance. *Annales de Micrographie* Nos. 4 et 5. Avril et Mai, 1898, pp. 113-151, 2 Planches.

The St. Louis Microscopical Society met November 10th, and, after regular busi-

ness, the scientific programme was opened by Dr. Bremer, a resume of whose paper follows:

Dr. Bremer demonstrated crystalloids in diabetic and leukemic blood. Crystalloids can be demonstrated in normal as well as diseased blood, principally by means of Aethylene blue. In diabetes, especially in the juvenile form, there are, in the plasma, copious refractive bodies, reminding one, so far as their form is concerned, of bacteria. They are, however, easily distinguished from microorganisms by their refractive index and their behavior towards the basic anilin dyes. In the dried and unstained specimen, they give, owing to their great number, a characteristic appearance to the blood film, when examined with a low power (x 150). The blood looks "infected," as it were. The greater or lesser masses of these crystalloids seem to be proportionate to the gravity of the disease. Their increase suggests approaching coma. From the morphologic appearance alone, a diagnosis may be made.

In leukemic blood, large globular crystals are found which are of differentially diagnostic import. Neither in diabetes nor in leukemia is there fat to be found, as has often been asserted. Certainly the bodies demonstrated cannot be regarded as fat, since ether and alcohol do not dissolve them. A more extensive article on this subject is being prepared by Dr. Bremer.

The better makes of wooden slide boxes all have a groove in the middle of each end, in order that the slide nearest the end wall may be taken out more readily. It is surprising that the groove is always cut in the middle, for if one takes hold of the slide here the cover glass is usually soiled, or if the balsam is not thoroughly dry the preparation may be injured, especially in the case of large rectangular cover glasses. A groove at the middle is of no use whatever. The slide should be handled only at the ends and the groove should therefore be cut on one side; or better still, two grooves should be cut in each end, one on each side. If this is done, all difficulty experienced in removing the slides next the end walls will be entirely obviated.

J. H. S.

Botanical Laboratory, Ohio State University, Columbus, Ohio.

The curriculum in the Pharmaceutical department of Howard University, Washington, D. C., has been extended so as to include a special course in microscopy and bacteriology. The course will be under the personal direction of Prof. W. W. Alleger.

New York Botanical Garden Library



3 5185 00264 0470

