



7-11
410

100
100

Library of the Museum
OF
COMPARATIVE ZOÖLOGY,
AT HARVARD COLLEGE, CAMBRIDGE, MASS.

The gift of the *Zoölogical Society*

No. *100*
889-400-20. 891

JOURNAL

OF THE

ELISHA MITCHELL SCIENTIFIC SOCIETY,

VOLUME VI—PART I.

JANUARY—JUNE.

1889.

PERMANENT SECRETARY:

F. P. VENABLE, . CHAPEL HILL, N. C.

E. M. UZZELL, STEAM PRINTER AND BINDER.

RALEIGH, N. C.

1889.

OFFICERS.

1889-1890.

PRESIDENT:

H. T. BAINSON, M. D., Salem, N. C.

VICE-PRESIDENT:

H. B. BATTLE, PH. D., Raleigh, N. C.

RESIDENT VICE-PRESIDENT:

J. A. HOLMES, B. AGR., Chapel Hill, N. C.

PERMANENT SECRETARY AND TREASURER:

F. P. VENABLE, PH. D., F. C. S., Chapel Hill, N. C.

RECORDING SECRETARY AND LIBRARIAN:

J. W. GORE, C. E., Chapel Hill, N. C.

LIBRARY AND PLACE OF MEETING:

CHAPEL HILL, N. C.

TABLE OF CONTENTS.

	PAGE.
List of Officers.....	2
Historical Notes Concerning the North Carolina Geological Survey. Prof. J. A. Holmes	5
Turpentine and Rosin. Dr. W. B. Phillips.....	19
The Creosoting of Wood with Wood Creosote Oil. I. H. Manning.....	27
Botany as a Disciplinary Study. Gerald McCarthy.....	33
Records of Meetings.....	38

JOURNAL
OF THE
Elisha Mitchell Scientific Society.

HISTORICAL NOTES CONCERNING THE NORTH
CAROLINA GEOLOGICAL SURVEYS.*

J. A. HOLMES.

There are three North Carolina State surveys that have been called geological surveys: (1) the "Geological and Mineralogical Survey," conducted by Professors Denison Olmsted and Elisha Mitchell (1824-'28), here termed the Olmsted-Mitchell survey; (2) the "Geological, Mineralogical, Botanical and Agricultural Survey," prosecuted under Professor Ebenezer Emmons (1852-'61 or '64), here called the Emmons survey; and (3) the "Geological, Mineralogical, Botanical and Agricultural Survey," prosecuted under Professor W. C. Kerr (1866-'85), here termed the Kerr survey. The last mentioned of these may be considered as in part a continuation of the second.

OLMSTED-MITCHELL SURVEY, 1824—1828.*

This "Geological and Mineralogical Survey" was proposed by Professor Olmsted in a letter laid before the State Board of Internal Improvements of North Carolina, December 1st, 1821. (Preserved in the Executive office, Raleigh). The Board approved, and presented the matter to the Legislature. The

*Abstracted from a more elaborate sketch prepared by the writer for the U. S. Geological Survey, and published by permission of the Director.

Legislature took no action in the matter, however, until two years later, when the proposition was renewed. The survey was authorized by act of the General Assembly, ratified December 31st, 1823. This act made it the duty of the "Board of Agriculture of North Carolina to employ some person of competent skill and science to commence and carry on a geological and mineralogical survey of the various regions of this State."

Denison Olmsted (at that time Professor of Chemistry, Geology and Mineralogy in the University of N. C.) was appointed by the Board of Agriculture to make the survey, and prosecuted the work during the University vacations* of the years 1824 and 1825. In the latter part of 1825, Olmsted resigned (to accept a professorship at Yale College), and was succeeded by Elisha Mitchell, both in the professorship in the University and as geologist of the survey. The work of the survey was prosecuted by Professor Mitchell during the University vacations, beginning late in 1825 and continuing through 1828. The only assistant employed in the work of the survey was Charles E. Rothe, a "miner and mineralogist from Saxony," engaged for a short time by Professor Olmsted in 1825 to make an examination of portions of the "great slaty formation" (Huronian of Kerr) which crosses the State.

The general purposes of the survey appear to have been, on the part of Professor Olmsted (who proposed it) and Professor Mitchell, the opportunity to become acquainted with the geology and mineralogy of the State, and to procure specimens of rocks and minerals illustrative of the same, and, on the part of the State, the discovery of mineral deposits of value within the State, and the publication of reports, in which these deposits should be described and the value and uses of the minerals made known to the people.

The survey was sustained by an annual appropriation of two hundred and fifty dollars (\$250), continued for five years. This amount was each year paid over to the geologist, and out of it

*Amounting to six weeks during the summer and four weeks during the winter.

he bore all expenses of the survey, exclusive of publication. The geologist's regular salary as professor in the University (\$1,240) was continued during his connection with the survey.

Small collections of rocks and minerals were made by both Olmsted and Mitchell and deposited at the State University; but these have disappeared.

As to results: The survey is now of interest mainly from an historic stand-point as being the earliest of the American State surveys. It must be considered as little more than a rough geological reconnoissance of the State, during which special attention was given to minerals of economic importance. And when one considers the condition of geological science at the time the survey was made, the lack of experience in making geological surveys, the limited time and fund at the disposal of the geologists, but little more can be expected. Both Olmsted and Mitchell did work of permanent value in locating and describing briefly the geological formations of the middle and eastern sections of the State.

The publications of the survey consisted of four small annual reports, each published as a part of a small volume of reports, essays, etc., and distributed free, under the direction of the State Board of Agriculture. The number of copies of each annual report published was fifteen hundred.

BIBLIOGRAPHY:

Report on the Geology of North Carolina, Part I; by Denison Olmsted. Raleigh, 1824, 12 mo., 41 pp.

Report on the Geology of North Carolina, Part II; by Denison Olmsted. Raleigh, 1825, 12 mo., 58 pp.

Report on the Geology of North Carolina, Part III; by Elisha Mitchell. To which is added a paper on Gold Mines of North Carolina, by C. E. Rothe, reprinted from Silliman's Journal for 1825. Raleigh, 1827, 12 mo., 43 pp.

Geological Report of Professor Mitchell. 1829, 12 mo., 8 pp.

After the discontinuance of the Olmsted-Mitchell survey (1828) Professor Mitchell for several years continued to make

geological explorations through different portions of the State, at his own expense. The general results of these explorations he published, in 1842, in a small text-book (*Elements of Geology, with an outline of the Geology of North Carolina; for the use of the students of the University.* 1842, 12 mo., 141 pp., with a geological map of North Carolina).

No further organized State work in geology was undertaken until 1852.

EMMONS SURVEY, 1852—1864.

The act authorizing this survey was passed by the General Assembly at its session of 1850-'51, and ratified January 24th, 1851. This act, under which the survey was organized and conducted, specified that the Governor should appoint some suitable person to make a "Geological, Mineralogical, Botanical and Agricultural survey of the State," and to prepare for publication reports embodying the results of his investigations, and, when practicable, to deliver lectures on these subjects in the villages of the State. The geologist was to appoint, subject to the approval of the Governor, such assistants as were necessary.

The survey was sustained by an annual appropriation of five thousand dollars (\$5,000), authorized by the act establishing the survey, to be paid upon the warrant of the Governor, out of the State Treasury. This was expended under the direction of the geologist, mainly, in payment of salaries. The geologist and assistants bore the ordinary expenses of the survey. Publication was paid for out of the State Treasury.

Professor Emmons was appointed geologist by Governor Reid, October 8th, 1851. The work of the survey was begun in January, 1852, and continued until the breaking out of the Civil War, in 1861. Nominally the survey was continued until April, 1864; but during the war the geologist and assistant were engaged in procuring and manufacturing munitions of war and economic mineral products needed by the people of the State. Professor Emmons died October 1st, 1863, and the assistant geologist, Ebenezer Emmons, Jr., resigned April, 1864, which latter date marks the conclusion of the Emmons survey.

The *general purpose* of the survey was the investigation of the geology, natural history and natural resources of the State. But among these, the object which stood out more prominently and was more influential in leading to the establishment and maintenance of the survey, was the development of the mineral, mining and agricultural interests of the State.

As to the *methods of operation* adopted by the survey, only general statements can be made. The larger part of the work of the survey, in the field, office and chemical laboratory, was done by Professor Emmons and E. Emmons, Jr. Professor Emmons was the geologist, chemist, mineralogist, paleontologist and agriculturist of the survey. The assistants employed, except in the case of Dr. Curtis, were general assistants rather than specialists.

The work of the survey was mainly in connection with the general geology, mining, agriculture and paleontology. In the field work these were given prominence according to their relative importance in the regions being examined. In topography, practically nothing was attempted. In botany and zoölogy, Dr. Curtis' work appears to have consisted mainly of the writing up for publication the results of his observations previously made.

In general geology, the formations east of the Blue Ridge appear to have been examined with considerable care, as to outlines, lithological and stratigraphical characteristics, and fossil remains (where these occur). Many results of these examinations were published in the reports for 1856 and 1858, but many of them were lost in the form of MSS. or field notes. In the region west of the Blue Ridge only a partial reconnoissance appears to have been made, the results of which were nearly all lost in the form of MSS. or field notes. In paleontology, a number of both vertebrate and invertebrate fossil remains were discovered and described from the eocene, miocene and cretaceous marl pits and river bluffs of the eastern region; as were also the remains of several interesting species of vertebrates, and a rich fossil flora from the Deep and Dan River coal fields of the older mesozoic. (See Emmons' N. C. Reports for 1856 and 1858,

American Geology, etc.). In mining, the principal then known, mineral properties of the State, were examined, drawings made of the veins and works, and, in many cases, analyses made of the ores. Of the results of these examinations, only a part was published; others were lost during the war. In agriculture, observations were made concerning the soils, their composition, products, and, through the reports of the survey, information was given as to methods of improving soils, etc.

The chemical work included analyses of soils, farm products, ores, minerals, rocks, mineral waters, etc. A room in Professor Emmons' private house, fitted up for the purpose, constituted the laboratory.

Among the *additions to science* made by the survey may be mentioned: (1) the rich flora of the Deep River coal fields (mesozoic), where were found about forty species, nine of which appear to be peculiar to North Carolina; (2) four new species of fossil fish and batrachians, eight species of reptiles and four of mammals, including the interesting insectivorous mammal, *Dromotherium sylvestre*, in the older mesozoic of Chatham county, and a few species of molluses.

The cabinet of the survey, located in the capitol building at Raleigh, contained a considerable number of specimens of rocks, minerals, ores, fossil plant and animal remains, soils, marls, etc., and was said to be one of considerable value. At the close of the Civil War (1865) it was nearly destroyed by soldiers passing through the city. The remnant was transferred to the State University, where it is at present.

PERSONNEL OF THE SURVEY:

Professor Ebenezer Emmons, M. D., Geologist, in charge of the Survey, 1851-'63, appointed by Governor Reid, October 8th, 1851, began work January, 1852, and continued in charge of the survey up to the date of his death, October 1st, 1863.

Ebenezer Emmons, Jr., assistant geologist, 1852-'64, was general assistant in the field, laboratory and office work.

Spence McClenahan, assistant geologist, 1852-'54, was engaged mainly in making a geological and topographical survey of the Deep River coal field and adjacent sandstone region.

Matthew B. Conklin, assistant geologist, April 1st, 1858—March 31st, 1860, was engaged mainly in collecting fossils and other specimens.

C. D. Smith, assistant geologist, 1859, engaged during a few months in making a geological reconnoissance of the extreme western region of the State.

Moses A. Curtis, D. D., botanist and zoölogist, 1860-'62, was employed to prepare for publication by the survey reports on the botany and zoölogy of the State.

BIBLIOGRAPHY:

Report of Professor Emmons on his Geological Survey of North Carolina. Raleigh, 1852, 12 mo., 181 pp. Five thousand copies published.

Report on the Progress and Present State of the Geological and Agricultural Survey of North Carolina; by Ebenezer Emmons. Raleigh, 1855, 12 mo., 20 pp.

Geological Report of the Midland Counties of North Carolina; by Ebenezer Emmons. New York and Raleigh, 1856, 8 mo., XX, and 351 pp., 9 plates, 7 maps and sections. One thousand copies published.

National Foundry—Deep River, North Carolina. Special Report of Dr. E. Emmons, Geologist to the State of North Carolina, concerning the Advantages of the Valley of the Deep River as a Site for the Establishment of a National Foundry. Raleigh, 1857, 8 vo., 14 pp.

Report of the North Carolina Geological Survey. Agriculture of the Eastern Counties, together with Descriptions of the Fossils of the Marl Beds; by Ebenezer Emmons. Raleigh, 1858, 8 vo., XVI, and 314 pp. Two thousand copies published.

Agriculture of North Carolina, Part II; containing statement of the principles of the science upon which the practices of agriculture as an art are founded; by Ebenezer Emmons, State Geologist. Raleigh, 1860, 8 vo., 112 pp.

North Carolina Geological Survey, Part II; Agriculture. Containing descriptions, with many analyses, of the Soils of the Swamp Lands; by Ebenezer Emmons, State Geologist. Raleigh, 1860, 8 vo., 95 pp.

Geological and Natural History Survey of North Carolina, Part III; Botany. Containing descriptions and history of the Trees, Shrubs and Woody Vines; by Rev. M. A. Curtis, D. D. Raleigh, 1860, 8 vo., 123 pp.

Legislative Doc. No. 25. Appendix B. Gen. Assem., Sess. 1860-'61. A Report on the Natural Resources of that Part of North Carolina west of the Blue Ridge; by Ebenezer Emmons. Raleigh, 12 mo., 3 pp.

Document No. 26. Gen. Assem., Sess. 1860-'61. Geological and Agricultural Survey. A Report of Progress; by Ebenezer Emmons. Raleigh, 12 mo., 6 pp.

Agricultural, Geological and Descriptive Sketches of Lower North Carolina and the Similar Adjacent Lands; by Edmund Ruffin, of Virginia. Raleigh, 1861, 8 vo., 294 pp.

Geological and Natural History Survey of North Carolina, Part III. Botany; containing a catalogue of the Indigenous and Naturalized Plants of the State; by Rev. M. A. Curtis, D. D., F. A. A. S., etc., etc. Raleigh, 1867, 8 vo., 158 pp.

Unpublished Reports:—It appears that at the beginning of the Civil War there was on hand by Professor Emmons MSS. material for publication sufficient for one or more large octavo volumes relating especially to the agriculture, mining and mineral resources of the middle and western regions of the State; also in preparation a geological map of the State and a geological map of the Deep River coal fields, ready for publication; all of which appear to have been lost or destroyed during the war. There was also nearly or quite ready for publication reports by Dr. Curtis on the Quadrupeds and Reptiles and the Birds of North Carolina, neither of which has been published, nor can be found at present.

KERR SURVEY.

The Kerr Survey was organized under the same law and with the same general functions as the Emmons Survey, of which it may be considered, in some respects, a continuation.

Professor Kerr was appointed State Geologist in 1864, and held the position nominally during the last year of the war, but no appropriation was made for the survey and no geological work was undertaken.

During the following year, 1865-'66, the survey does not appear to have had even a nominal existence. Professor Kerr was re-appointed April, 1866, the survey was reorganized, and its work resumed. In 1877, by legislative enactment, the geological survey, which formerly had existed as an independent organization, was made a co-operative department with the Department of Agriculture, and the State Chemist was made chemist *ex officio* to the survey; and in 1879 changes made in the law governing the survey brought the work of the latter still more under the control of the Department of Agriculture. The field work of the survey was practically discontinued in 1882, when Professor Kerr resigned to accept the position of Geologist on the United States Geological Survey, but was continued at intervals until his death in 1885.

The survey was sustained by an annual appropriation of \$5,000, which covered all expenditures, including salaries, except that of publication.

The general *plan of operations* was an outgrowth of the great variety and extent of the work to be done, and the smallness of the appropriation, and as many of the results obtained by the Emmons survey having been lost during the war, others were out of date, and it was necessary that the work of the Kerr survey be extended over the entire State and investigations pursued with more modern methods. The general work of the survey was undertaken by Professor Kerr in person. In the several divisions of the work specialists and general assistants were engaged when needed. A list of these is given below under *personnel*.

In topography a considerable amount of work has been done by the survey, especially in the western portion of the State, since no topographical survey of that region had been made, and a more accurate map was needed as a base for the geological map. The necessary preliminary work was undertaken by the Geological Survey, and was carried on by Professor Kerr and his assistants at intervals, along with the field work in geology. Much of the topographical work was done somewhat hurriedly, but with as much detail and care as circumstances would permit, with the use of the pocket compass, pocket level, aneroid or mercurial barometers, pocket or marine sextant and chronometer (for obtaining latitude and longitude where necessary). A map of the State, embodying the results of many of these observations, together with data compiled from various other surveys, was published in 1882.

In general geology the work has been done by Professor Kerr in person. All the geological formations within the State have been examined, their outlines and general characters as to lithology, soils, topography, etc., noted. In this department, however, much detail work still remains to be done in all parts of the State.

In lithology the collections of crystalline and metamorphic rocks were submitted to Professor A. A. Julien (who has several times visited the region in person) for microscopic examination. His report is now in preparation.

In mineralogy the collections were in most of the cases submitted to Dr. F. A. Genth, whose reports are to be found in Kerr's *Geology of North Carolina*, Vol. I, 1875, Appendix C., and Vol. II, Chap. I, 1881.

In vertebrate and invertebrate paleontology the collections of the survey were submitted to Professors E. D. Cope and T. A. Conrad, respectively, both of whom, without remuneration, twice visited the State for the purpose of examining specimens and making collections. Their reports are to be found in Kerr's *Geology of North Carolina*, 1875, Appendix A.

In meteorology about thirty volunteer stations were established by the survey in different regions of the State, where observations have been taken with more or less regularity, as to the temperature, rain-fall, clouds, winds, and, in a few cases, atmospheric pressure and dew-points.

In chemistry the work included the analyses of soils, marls, minerals, the assay of ores, etc. From 1866 to 1877 the survey did not have adequate laboratory facilities, and specimens for analysis were mainly sent to the laboratory of specialists not connected with the survey. Subsequent to 1877 this work was done by the State Chemist, who was, by legislative enactment, *ex officio* chemist to the survey.

In agriculture the work done by the survey consisted in the analysis of soils, marls, fertilizers (prior to 1877), and the instruction of the people of the State, through the press and lectures by the geologist, as to the methods of improving soils.

In connection with the mining interests, the principal mining properties were examined by the geologist in person, and analyses or assays made of the ores were in many cases made under his direction.

The Museum of the survey, located in Raleigh, contains the following collections: Of minerals and ores, about six thousand specimens; rocks (hand specimens), about three thousand; building stones (a foot cube and less), about one hundred; soils and marls, nearly two hundred; fossil vertebrate remains, a small collection; fossil shells, several thousand specimens, including a large number of species from the cretaceous and tertiary deposits of the State; shells of living forms, land, fresh-water and marine, a small collection of each; native woods, upwards of two hundred specimens; small collections of Indian antiquities and agricultural products; and a few miscellaneous specimens, among which may be mentioned the skeleton of a whale (*Balæna mysticetus*) 65 feet in length.

The Library of the survey contains three hundred volumes, including treatises on geology, mineralogy, metallurgy, agriculture and general natural history, partial sets of the American

journals devoted to these subjects and reports of other State surveys. This library is supplemented by the much larger State Library in the adjacent capitol building.

PERSONNEL OF THE SURVEY :*

Professor W. C. Kerr, Director and Geologist, 1866—1882. His connection with the survey continued, irregularly, until his death, 1885.

Charles J. Curtis, assistant in topography, field work, during the summers of 1866 and 1868.

Professor N. A. Pratt, of Charleston (now of Atlanta), chemist, 1866—1867. Made a few chemical analyses of supposed phosphatic marl.

Captain William E. Cain, assistant in topography, at irregular intervals, from 1867 to 1882, in both field and office work.

Professor E. D. Cope, of Philadelphia, volunteer assistant in vertebrate paleontology, 1868-'69.

George B. Hanna, assistant in chemistry and assaying, at irregular intervals, 1869-'77, and mining in 1883.

Professor T. A. Conrad, of Philadelphia, volunteer assistant in invertebrate paleontology, 1870 and 1871.

George C. Jordan, special assistant, labeling and arranging cabinet collections, six months of 1870.

E. H. Bogardus, of the New Jersey Survey, special assistant in chemistry, making analyses of soils and marls, at intervals, 1870—1874.

Professor C. H. Chaudler, of New York, made a few chemical analyses in 1871.

Dr. F. A. Genth, of Philadelphia, assistant in mineralogy, 1871 and 1880.

Mrs. C. P. Spencer, engaged mainly in coloring a geological map of the State during a short time of the winter of 1871-'72.

W. D. Cooke, special assistant, on geological map, tabulating data and other office work, at intervals, 1872-'76.

*Persons residents of North Carolina when it is not otherwise stated.

C. D. Smith, special assistant in geology and mineralogy for the region west of the Blue Ridge Mountains during portions of 1872, 1873 and 1874.

Professor Alexis A. Julien, of New York, lithologist, at intervals, 1875 to present date.

Dr. A. R. Ledoux, chemist *ex officio*, while State Chemist, 1877-'80.

T. C. Harris, curator of the museum and assistant in engraving and general office work, 1878 to present date.

A. G. Williamson, of Virginia, assistant in topography during a few autumn and winter months of 1879-'80.

R. G. Thomas, office assistant, tabulating meteorological data, December, 1880, to February, 1881.

C. W. Dabney, chemist *ex officio*, while State Chemist, 1880, to present date.

W. B. Phillips, assistant in geology, parts of 1881 and 1882, and acting State Geologist August, 1882, to February, 1883.

W. H. Kerr, field assistant in collection of building stones during a few months of 1882.

The names of meteorological observers connected with the survey are omitted for want of space.

BIBLIOGRAPHY:

Report of Progress of the Geological Survey of North Carolina, 1866; by W. C. Kerr, Raleigh, 1867, 8 vo., 56 pp. Number of copies published, 3,640.

Exec. Doc. No. 27, Sess. 1868-'69, Gen. Assem. of N. C.

Report of Progress of the Geological Survey; by W. C. Kerr. 1869, 57 pp.

Appendix to the Report of the Geological Survey of North Carolina, 1873, being a brief abstract of that report and a general description of the State, geographical, geological, climatic and agricultural; by W. C. Kerr. Raleigh, 1873, 8 vo., 24 pp. and map. Number of copies published 5,000.

Pub. Doc. No. 16, Sess. 1872-'73, Gen. Assem. of N. C. Report of Progress of the Geological Survey of North Carolina; by W. C. Kerr. 8 vo., 4 pp.

Report of the Geological Survey of North Carolina, Vol. I; Physical Geography, Resumé, Economic Geology; by W. C. Kerr. Raleigh, 1875, 8 vo., XVIII, 325 and 120 pp., 9 plates and a geological map. Number of copies published, 1,000.

Pub. Doc. No. 21, Sess. 1876-'77, Gen. Assem. of N. C. Report of the State Geologist on the Expenditures of the Geological Survey; by W. C. Kerr. 8 vo., 17 pp.

Pub. Doc. No. 32, Sess. 1876-'77, Gen. Assem. of N. C. Report of State Geologist concerning the Establishment of a Department of Agriculture, etc.; W. C. Kerr. 8 vo., 12 pp.

Physiographical Description of North Carolina; by W. C. Kerr. Raleigh, 1879 and 1882, 8 vo., 32 pp.

Minerals and Mineral Localities of North Carolina, being Chapter I of the Second Volume of the Geology of North Carolina; by F. A. Genth and W. C. Kerr. Raleigh, 1881, 8 vo., 122 pp. Five thousand copies published.

Map of North Carolina; by W. C. Kerr, State Geologist, assisted by Captain William Cain, C. E. New York, 1882. Scale, 10 miles to the inch.

Ores of North Carolina. Being Chapter II of the Second Volume of the Geology of North Carolina; W. C. Kerr and George B. Hanna. Raleigh, 1888, 8 vo., 237 pp. (123—359), and a mining and geological map of North Carolina. Three thousand copies published.

The following unfinished reports are in preparation:

Geology of North Carolina, Vol. II of Kerr's Reports, embodying the results of the survey from 1875 to 1885, in preparation under the direction of Professor J. A. Holmes; and a report on the Lithology of North Carolina, in preparation by Professor A. A. Julien.

PRODUCTS OF THE PINE.*

No. I.

TURPENTINE AND ROSIN.

W. B. PHILLIPS, PH. D.

Gentlemen of the Society:—It is designed in this paper to call the attention of the Society very briefly to some of the more salient features of the industry which, in the minds of most people, is associated with the name of North Carolina. In almost every text-book on the Geography and Resources of the United States the chief products of North Carolina are said to be Tar, Pitch and Turpentine, and, of late, Rosin, in spite of our 40,000,000 pounds of tobacco and 250,000 bales of cotton.

North Carolina is known as the great naval store State. Has not our chief city been built up mainly through its trade in the products of the pine tree? Is not the Cape Fear the most turpentiney stream that flows? Are we not ourselves true Tar Heels? But if we were called upon to give a definition of Tar, or Pitch, or Turpentine, or Rosin, I fear that many of us would return rather misty replies. It is very generally true that our knowledge of some of the most common articles of every-day life is extremely superficial. This arises not so much from objective as from subjective difficulties. The obstacles are esoteric. Familiarity, if it does not breed the usual contempt, does breed what is worse, a profound indifference

It is with the hope that this indifference may be somewhat disturbed, if not entirely removed for the time being, that I desire to speak to you this evening on Turpentine and Rosin, twin products of the Long-leaf Pine.

On the Atlantic coast, throughout a tract of land 600 miles long by 100 miles wide, beginning at Norfolk, Va., and ending

*A series of articles will follow on this subject.

in the southern part of Georgia, there grows a pine tree, known to botanists as the *Pinus Australis*, to ordinary people as the Long-leaf Pine. Its height is from 60—80 feet, its diameter 2 feet above the ground from 1 to $2\frac{1}{2}$ feet. It has a thin bark, a cone from 6—8 inches long and from 4—6 inches across at the base, a wood with very little sap, and a leaf 10—18 inches long arranged in triplets in the sheath. A tree 60—70 feet in height has generally a diameter of 15—18 inches for 40 feet. This tree has also other names besides the two just quoted, as, for instance, with us it is sometimes called yellow pine, pitch pine and brown pine. Exported to the Northern States it is known as Southern pine and red pine; while in England and the West Indies it is termed Georgia pitch pine. For three-quarters of a century it has been the chief source whence the supplies of Turpentine and Rosin were drawn, and it will continue to be so for many years to come, as we have in this State alone more than five billion feet of merchantable Long-leaf pine standing. And as a dead tree can hardly be considered merchantable, we may feel satisfied that the supply will last for many years yet.

Our word turpentine is from the Latin *terebinthus*, meaning the terebinth, or turpentine tree. Mention is made of this turpentine tree in very early days, 2,000 years B. C., when Abraham first went into Canaan, *vid. Gen.*, XII, 6: “Plain of Moreh” should be “grove of turpentine trees at Moreh.”

While Rosin (more correctly Resin, which is the older word), at one time derived from the Greek word meaning to flow, is now compared with the Sanskrit *rāla* (the resinous exudation from the *Shorea Robusta*, or the “Sāl” tree of Northwestern India). The resinous exudation from this tree is much like copaiva balsam, and a most costly camphor, Malay or Sumatra camphor, is obtained from it.

But what *is* Turpentine?

If I were to say that Turpentine is *not* Turpentine, perhaps I would be regarded as making a very foolish assertion. And yet it is even so. What we call Turpentine in common life is a very different thing from the Turpentine of commerce. In trade the

crude gum which exudes from the pine is called Turpentine, in common life one of the volatile products of the distillation of this gum is called Turpentine. In other words, in trade the *distillant* is Turpentine, in common life the *distillate* is Turpentine. What we call Turpentine is in the trade called "spirits," or spirits of Turpentine. In most text-books on chemistry mention is made of "oil of turpentine," a term not used in commerce, meaning spirits of Turpentine.

What is Rosin? Rosin is the residue left in the still after the extraction of the "spirits." It is strained, cooled by exposure to the air, and allowed to crystallize.

You will, therefore, please consider the term Turpentine as meaning the crude gum (before distillation); the term "spirits," or Spirits of Turpentine, as meaning the most important substance distilled off from this gum, and Rosin the residue left in the still, drawn off while hot, strained and crystallized.

There are three kinds of Turpentine, viz.: virgin, yellow-dip and scrape.

There are four kinds of spirits, viz.: white spirits and 1st, 2d and 3d "*shade*."

Of Rosin, excluding "opaque Rosins," there are fourteen different kinds, viz.: A., B., C., D., E., F., G., H., I., K., M., N., W. G. and W. W. Of these the highest grade is W. W. (water-white), beautifully clear and transparent, and almost colorless. Then W. G. (window-glass), also clear and transparent, but a shade darker in color than the W. W. Then N. Rosin, also clear and transparent, but a shade darker than W. G. And so on down to A., omitting L. and J., each letter signifying a Rosin of darker color, until when A. is reached the Rosin is black and allows no ray of light to pass through. And I may say just here that there are two main causes of the difference in color between Rosins: 1st. The quality of the Turpentine. 2d. The care bestowed upon the process of distillation. W. W. Rosin is almost colorless, A. Rosin is black, and between the two lie various shades of very light amber, a dark wine-color, and black.

There are two kinds of opaque Rosin, viz. : water-opaque, in which the opacity is due to admixed water, and spirit-opaque, or "Coachey" Rosin, in which the opacity is due to admixed "spirits." Both are whitish and non-transparent.

Let us now consider more in detail the Turpentine, or crude gum. Suppose we have a small forest of 10,000 trees, which have never been worked for Turpentine. The first thing to be done is to "box" them. The "box" is made on the side, preferably on the south side, of the tree from 4—6 inches above the ground, by cutting into the tree from above, sloping the cut across the grain of the wood, and then meeting this cut with another at an angle of 5° — 10° . The chip taken off leaves a cut on the side of the tree, holding about two pints, and known as the "box." If the winter is mild and open this operation is begun during the month of December, and carried on through January, February, and into March. Ten thousand (10,000) trees constitute a "crop," and one man cuts the boxes. At the first approach of warm weather the Turpentine begins to exude from between the bark of the tree and the wood, runs down the incline and into the box, from which it is taken with wooden or iron scoops and put into barrels, preparatory to being carried to the still.

If the weather be favorable the trees will yield Turpentine for seven months the first year, beginning with April and ending with October. During that time about 18 inches of the bark of the tree are removed, so that at the end of the first year we have cut the box and removed 18 inches of bark. From 7 to 9 collections are made from each tree during the season, and as each box holds 2 pints, we get from 7 to 9 quarts per tree in a season. We have 10,000 trees, so that we should have at the end of the first year from 17,500 to 22,500 gallons of Turpentine, all of it "virgin," *i. e.*, of the very best quality. It is common to estimate the yield of 10,000 trees for the first year at 250—300 barrels of "virgin." The standard weight of a barrel of Turpentine is 280 pounds, which includes the weight of the barrel, but, in reality, these barrels seldom weigh so little as 280 pounds, ranging from 280—325 pounds. If we have selected the bushy top, thin

bark trees, growing in a sandy, dry soil; if we have cut our "boxes" properly, and attended them carefully, and had good weather, we should get 280 barrels of 300 pounds each of "virgin dip."

What shall we do with it? How can we obtain spirits of Turpentine and Rosin from it? By distilling it in a copper still. Formerly iron stills were used, but they imparted a reddish tinge to the spirits, so now copper stills are used, holding from 6—50 barrels of Turpentine, the ordinary size holding 15 barrels.

Turpentine may be regarded as a mixture of spirits of Turpentine, water and Rosin. The water, of course, boils at 100° C., the Rosin melts at 100° , and above 150° C. is gradually decomposed. The "spirits" boils at 158° C. Up to 100° C., then, very little will come over except water. Mixed with the water is a certain amount of pyroligneous acid, methyl alcohol, ether, and, perhaps, formic acid, which mixture is termed "low wine," and is frequently used by the laborers for kidney troubles. As the heat rises above 100° C. the "spirits" begins to come over, being yielded most abundantly, of course, at its boiling point, 158° C. The "spirits" accumulates on top of the low wine in the tub, and runs into a separate tub through a cock near the top of the first one. Of course in such a viscid mass as "virgin dip" it is only by long continued boiling, even at temperatures above 100° C., that the water is expelled, so that a good deal of water comes over with the "spirits," and the boiling is kept up until the proportion of spirits and water in an ordinary tumbler-full is 1 of spirits to 8 or 9 of water, *i. e.*, from $1\frac{1}{2}$ — $2\frac{1}{2}$ hours. But where does all this water come from? It cannot all exist in the Turpentine, and, so far as known, it is not a decomposition product. It is added to the Turpentine in the still either at the beginning of the distillation or after it has been in progress for an hour. Its office appears to be to assist in the expulsion of the "spirits," by causing a more violent bubbling and boiling, with consequent vesiculation of the mass in the still. Operating with "virgin dip," *i. e.*, the yield of the first year, the distillation is stopped before all the "spirits" is driven off, so

that the Rosin may contain about 15 per cent. of the original content of spirits. At the proper time the cap of the still is removed, the liquid mass inside skimmed of trash, run out through a bottom cock, strained through wire and cotton batting and allowed to cool in the bins. The temperature of the Rosin as it comes from the still is 160° C. It cools very slowly, so that at the end of 4 hours, with an external temperature of 60° , it lost in one experiment only 60° F., and that after it had been ladled into barrels.

From fifteen 280-pound barrels of "virgin dip" there should be obtained not less than 105 gallons of "spirits" and 2,100 pounds of Rosin. A good working rule is to allow two-thirds of the weight of the Turpentine for Rosin and one-third for "spirits" and water. Ten thousand trees should yield the first year 280 barrels of "virgin," the second year 240 barrels of "yellow dip" and scrape, the third year 200 barrels of "yellow dip" and scrape. Or, in other words, for the yield of each year after the first year subtract one dipping of 40 barrels per year.

All that is collected from the trees the first year is called "virgin," and yields the best spirits and the finest Rosin. After the first year the turpentine is called yellow dip, and scrape, and yields inferior Rosin, and generally not so good spirits.

While, indeed, it is for the most part true that "virgin dip" yields the finest Rosin, yet it may yield the darker Rosins by too high a heat in the still. This has been denied, but the weight of evidence is clearly in its favor. In the endeavor to extract as much "spirits" as possible from the "virgin dip" and still leave the Rosin pale, it sometimes happens that the temperature of decomposition is reached and passed, and instead of a pale Rosin a darker one may come from the still. "Yellow dip" and scrape never yield pale Rosins. Whether this is due to chemical changes in the Turpentine before distillation, or to the action of foreign organic matter on the Turpentine during the distillation, or to the complete expulsion of the spirits, no definite answer can be made. It has been stated that about 15 per cent. of the original content of "spirits" is left in the Rosin from "virgin dip." This

is supposed to give to the pale Rosins their transparency and lack of color. But in distilling "yellow dip" and "scrape" no "spirits" is left in the Rosin. The effort to expel the spirits completely may cause too high a heat in the still, with consequent darkening of the Rosin.

Again, as "yellow dip" and scrape are exposed to the air longer than virgin dip, having to traverse oftentimes several feet of "face," oxidation products may arise, and influence the final color of the Rosin.

Again, there is always much more foreign matter mixed with yellow dip and scrape than with virgin, and the heat of 160° C. for an hour or two, in the presence of water, would doubtless extract from these pine leaves, bark and chips more or less of their coloring matter, which might well affect the color of the Rosin. The New York Standard Rosins are divided into 12 grades, viz., from the highest to the lowest:

W—	G—Low No. 1.
N—Extra pale.	F—Good No. 2.
M—Pale.	E—No. 2.
K—Low pale.	D—Good strained.
I—Good No. 1.	C—Strained.
H—No. 1.	B—Common strained.

These grades are used at Wilmington, Charleston and Savannah. But at Wilmington the arrangement, while essentially the same, has some minor points of difference.

Considerable experience is required before one can grade Rosin, and very few can do it without having the standards at hand, so as to compare constantly. After some time these "standards" acquire a lighter color, due to exposure to light, and this fact complicates the matter still farther. The higher grades of Rosin are worth from two to three times as much as the lower grades, and of course much interest has for years been manifested in the question of the possibility of bleaching the lower Rosins. Exposure to strong sunlight does raise the grade a degree or so in the course of several months, but this is not continuous. The main difficulty, I apprehend, is in our igno-

rance of what really constitutes the difference between the pale Rosin and the lower grades. I mean the chemical difference. Chemically, Turpentine is an oleo-resinous juice, consisting of resin and essential oil. The oil, or spirits, varying in amount from 15—30 per cent., consists, according to Flückiger and Hanbury (Pharmacographia, 1879, p. 606), “for the greater part of various hydrocarbons, corresponding to the formula $C_{10}H_{16}$,” while Rosin, or colophony, as they term it, may be regarded as composed largely of the anhydride of abietic acid, and has the formula $C_{44}H_{62}O_4$ (*id.* p. 607). They do not state what Rosin it is that may be so regarded, but we will suppose that it is the best, or the clear, transparent, nearly colorless Rosin, say the W. W. As you will observe from these specimens of the various grades, there is a most marked difference between the W. W. and “E.” or “D.” Rosin. The fact I wish to impress upon you is, that we do not know what causes this great difference in color, whether it is due to oxidation, hydration, incipient decomposition, either or collectively. The authors above quoted (p. 607) go on to say that the living tree contains only the abietic acid anhydride; that on exposure to the air the Turpentine loses oil (or “spirits”), takes up water and solidifies as the crystalline acid of formula $C_{44}H_{64}O_5$. The presence of the oil (or spirits) in the turpentine determines the assumption of this molecule of water which changes the amorphous abietic acid anhydride into the crystalline abietic acid.

As before remarked, Turpentine is a mixture of “spirits” and Resin. But the “spirits” itself can and does undergo resinification, which is, perhaps, an oxidation, as formic acid is produced. But the resinification of “spirits” does not produce resin, which, as yet, has been shown to be identical with any natural resin. Therefore, we cannot say that resins are oxidized “spirits.” A vast amount of chemical work must be done before one can say what is the chemical difference between the grades of Rosin. And yet, if the question of the conversion of the lower into the higher grades is ever settled on a firm basis, it will be settled by the practical chemist. *Quo difficilius, hoc præclare!*

PRODUCTS OF THE PINE.

No. II.

THE PRESERVATION OF WOOD WITH WOOD-CREOSOTE OIL.

J. H. MANNING.

In 1872, Mr. James D. Stanley, of Baltimore, Md., invented and patented certain retorts and arrangements for the production of "spirits of turpentine, oil, varnish and inflammable gas" by the distillation of pine wood. Wilmington offering the advantages of one of the largest naval store ports in the world, Messrs. Hansen & Smith of that city purchased in 1882 the patents and plant of Stanley for the purpose of more cheaply manufacturing these products and establishing a market for them. With certain improvements in the arrangement of retorts, they succeeded in manufacturing, but failed in securing a market for the oils. From this misfortune proceeded experiments with oil and the subsequent discovery of a process for using it in the preservation of wood. The antiseptic and preservative effects of creosote have long been known, and the effects of coal creosote in preserving timbers amply proved. By allowing lumber to soak in creosote oil and exposing the same, sufficient proof of its value was given, though the test in itself is insufficient, and better ways for impregnating the wood with oil were at once experimented upon.

Messrs. Hansen & Smith succeeded in perfecting machinery to this end, and until 1885 the process was carried out secretly on a small scale. This work was advertised and severest tests applied to their products. Not until 1885, when a stock company was formed, were patents issued for the process. This stock company, under the style of the Carolina Oil and Creosote Co., doing business in the city of Wilmington, has a capital stock

of \$500,000. There is a factory working under the same patents in Fernandina, Florida, and one about to be erected in Seattle, W. T.

The site of the factory at Wilmington is about $1\frac{1}{2}$ miles from Market street, on the south-western suburb, desirably located on the river. This plant has gradually increased from a valuation of \$30,000, with a capacity of 3,000 feet of lumber per day, to the present valuation of \$425,000, with a capacity of 40,000 feet per day. It consists of two parallel sheds for the protection of distilling retorts and a one-story building for reservoirs, pumps, boilers, creosoting cylinders, etc.

The most important preliminary step is the economic production of wood-creosote oil. For this purpose there are sixteen (16) retorts, arranged in batteries of two each for economy and convenience in firing, with a capacity of about 19,000 gallons creosote oil and the same amount of pyroligneous acid waste per month. These retorts are all similarly constructed, and hence a description of one will suffice for all.

A furnace substantially built of masonry, 26 feet long, 13 feet high and 10 feet wide, supports in its beds two retorts. It is divided in the centre by a thin, fire-clay partition, so there are actually four different and complete furnaces. Each fire-place has its roof, in the inner ends of which are flues for the escape of the heat into the retort space. The retort rests horizontally in its bed and fits snugly into masonry, resting on loosely-fitting iron bands, allowing an air space entirely around the retort to the partition in the centre of the furnace, only interrupted by vertical semi-circular divisions, alternating from top to bottom, for the purpose of securing a uniform distribution of heat, and serving also in rapidly cooling the retort. This retort is a cast-iron, or, preferably, steel cylinder, 26 feet long by 6 feet in diameter, having a capacity of $4\frac{1}{2}$ cords. Its ends are open, and may be closed by a perfectly-fitting cap with clamps, and by using asbestos or clay packing can be rendered air-tight. At the end of the retort a pipe 6 inches in diameter enters, and, gradually narrowing, conveys the gases to a copper worm through the con-

denser. This condenser alongside the furnace is a wooden vat 12 feet high and 10 feet in diameter, connected with the water-works, so as to secure a continuous flow of water, and contains a copper worm about 40 feet long, narrowing gradually to 1½-inch tube. On issuing from condenser this worm enlarges into a goose neck, or trap, in which the uncondensed gases and the liquid are separated. The gases are conveyed to another condenser and to the reservoir and are used for heating purposes. The liquid falls into a wooden vat of convenient shape and holding about 900 gallons, and connected by siphon and pump with reservoirs in the creosoting house. Each retort is a complete still, and a battery occupies a ground space of 26 feet by 26 feet. A retort, with ordinary care, should last 15 years. The working is simple. Good, resinous, fatty pine wood as having the highest content in oil is selected, and 4½ cords carefully laid in the retort, the ends sealed, and firing begun. The heat is gradually raised, driving off water, light gases and oils, until between 400° F. and 760° F. the heavy and most valuable oils distill. These are carefully condensed, not allowing the water in the vat to get more than lukewarm. The heating is kept up continuously for 26 hours, consuming about one cord of wood per battery, after which time the fires are removed and the retorts cooled as rapidly as possible. The charcoal, amounting to about 33 per cent. of charge, is raked out and meets with ready sale. The entire operation requires between 30 and 36 hours, with a yield of about 70 gallons creosote oil and 85 to 90 gallons pyroligneous acid waste per cord. The uncondensed gases being separated from liquid in the goose neck, are conveyed through another small condenser (recently added), wherein small quantities of oils are further condensed, passing over lime (unslacked), according to Stanley, and into reservoir, from which it is drawn and used for heating the retort. The distillate, upon standing (usually until the retort is charged again), separates into two liquids known as pyroligneous acid waste, consisting of water, pyroligneous acid, acetone, a small proportion of lightest oils and about 1 per cent. wood alcohol, and "creosote oils," consisting of 5 per cent. tar acids,

15 per cent. light oils and about 80 per cent. heavy oils. They may be completely separated with siphons and are pumped into their respective reservoirs. After longer standing, small quantities of oil separate from pyroligneous waste and are transferred to the oil tanks. The acid waste is sold to the Southern Chemical Co., and wood alcohol, crude pyroligneous acid and a black dye manufactured from it. It is also offered for sale as a cheap and reliable disinfectant.

The wood creosote oil is a very heavy black liquid, resisting the action of salt or fresh water, and is used principally in the preservation of wood, but patents have been issued for a mixture containing it for use as a "sheep dip," and it is recommended as an insecticide.

The creosoting plant consists in steel reservoirs, creosoting cylinders, pumps, etc. The steel reservoirs are constructed as the creosoting cylinders and are used for heating the oil preparatory to use. They are connected with the oil tank and creosoting cylinders, and contain a coil of steam piping connected with the boilers. The creosoting cylinders are made of steel guaranteed to stand 150—200 pounds pressure, and lie on a bed of masonry on a level with ground. They are of varying length (from 60 to 100 feet long by 6 feet in diameter), having open ends with perfectly fitting caps. These caps can be rendered air-tight with asbestos packing. Into this cylinder runs a tramway with a movable section at the doorway. Under this track there is a coil of piping, usually about six times as long as the cylinder, connecting with the boilers. In the top, at intervals, are screws attached to semi-circular iron bands, used for holding the charge in position, and adjustable from the outside. At the end are the various pipes connecting with suction pumps, force pumps and oil tanks.

This company has in operation four of these cylinders, one 65 x 6, 90 x 6, 75 x 6, 100 x 6, with a capacity of 40,000 feet per day, costing from \$800 to \$1,200. No estimate can be had of their durability. Those now operated have been in use for several years and are apparently as good as new.

The process of creosoting is carried out according to this general plan. Good, "sap" or porous pine lumber, with or without previous charring, is run into the cylinder on a truck and made fast in position by the screws outside. The ends are then sealed perfectly and the temperature raised gradually by superheated steam to about 550° F., the suction pump is applied and as near a complete vacuum as possible produced and sustained for about 14 hours. This treatment serves to dry the wood thoroughly and expands its pores to the fullest extent, leaving them empty for the entrance of the fluid. The suction pump is disconnected then and sufficient oil to fill the cylinders run in. The force pump is next applied, with a pressure as high as 120 pounds per cubic foot, which is sustained until the desired amount of oil has been injected. This is very easily calculated by knowing the capacity of the cylinder less the charge of lumber and the cubic measure of lumber, and as much more oil over the amount necessary to fill cylinder as has been consumed represents the amount injected into wood. The oil stands at about 400° F., and the temperature of the cylinder is reduced to that degree. The oil being injected, the surplus is withdrawn to tanks, the lumber run out and is ready for shipment, the entire process usually requiring about 24 hours.

Many circumstances modify this general plan. It is by the condition of timber that the time of drying is determined—whether it is very green or seasoned; small planks or large timbers; and as to duration of creosoting, whether small planks or large timbers, very porous or compact, and to the amount of oil desired injected. Upon the careful manipulation of this process depends the success of its product, and every precaution is taken to insure it. The timbers may or may not be previously charred. Any quantity of oil from 3 to 20 pounds per cubic foot may be injected, and any size timbers handled from 1 to 20 inches in diameter and up to 100 feet long.

Previous charring is recommended as increasing the absorbing power by at least 50 per cent. Twelve pounds of oil per cubic foot is considered sufficient in all ordinary circumstances—more

or less being used according to the purposes for which lumber is to be used. Twelve pounds of oil per cubic foot increases the cost over crude timber about 100 per cent., with an additional 5 per cent. for each additional pound of oil per cubic foot. The advantages over other processes is in the economy and a more thorough impregnation of wood with creosote.

The superiority of wood preserved by wood creosote oil has been conceded by English and American contractors. Besides being an excellent mechanical packing, it is a reliable germicide and preservative, and its odor is exceedingly offensive to all insects, especially the teredo. It is supposed that sufficient quantities of tarry acids are present to coagulate the albumen of the wood, thus rendering fermentation less liable to occur. The heavy oils resist the action of water and cannot be washed from the pores of the wood. Creosoted wood can be used in any and all circumstances, and without material injury to carpenter's tools. It is several degrees harder than ordinary timber, and hardens as it gets older. It is recommended particularly for use as sills, cross-ties, piles, wharfs, spars, decks and in every place where the conditions are most favorable to the decay of crude timbers—where, in tide-water countries, the piles are subjected to alternate drying and wetting, in tropical countries, and wherever the ravages of insects are greatest. Large quantities of it were sold to the Panama Canal Co. It has been sold as high north as Nova Scotia, and south as far as Rio, and the severest tests applied, in none of which has it failed.

By the rapidly increasing demand for it among all classes of builders and contractors, we are assured that it is to be one of our largest and most important industries, and our Southern pines will have been increased greatly in value.

BOTANY AS A DISCIPLINARY STUDY.

GERALD McCARTHY, B. Sc.

Of all branches of natural science the study of plants, viewed merely as an instrument of mental discipline, offers the greatest inducements for the majority of pupils. During three-fourths of the year trees, shrubs and flowers are the most abundant objects in nature. They greet the eye on every side, and by their graceful forms, beautiful foliage and pleasant odors invite our attention. Since the maintenance of animal and human life depends upon the pre-existence of the vegetable world, plants appeal to the sympathies of even the most hardened admirer of pavements and gas-light.

Appealing in so many ways to human sympathies the study of plant-life is admirably fitted for awakening and stimulating the embryonic or dormant faculties of the mind. The facts with which this study stores the mind are interesting, useful and easily comprehended by even the very young, while riper and more disciplined minds will find therein unsolved problems worthy of the most extended reflection.

A few of the benefits conferred by a systematic study of plant-life may be here enumerated:

1. Plants are peculiarly adapted for cultivating in the student a love for form, symmetry and color—for stimulating the æsthetic faculties, faculties almost wholly and lamentably neglected in our common schools.

2. The study of plants trains the mind to habits of close observation and discriminating judgment, orderly arrangement and the “logic of systematization.” All of these habits are of the very greatest utility to every human being.

3. The study of plant-life introduces the student to the study of the phenomena of life in its least complicated manifestations. The fundamental laws of organic life are the same in plants and

in animals, but in the case of animals and human beings the phenomena are so complex as to be quite beyond the power of comprehension of the beginner. The person who has studied the laws of nutrition, growth, reproduction, degeneration and extinction as exhibited in the vegetable kingdom will be well prepared to profit at a later period when he takes up the subject of animal and human physiology.

4. Plants can be studied far more thoroughly than is practicable with minerals and animals—in the case, at least, of young persons and those who have not at hand complex and costly apparatus and chemical re-agents often dangerous to handle. The lack of thoroughness in everything is the bane and scandal of our American schools, and the direct cause of the superficial character of so much of our literature, morality and laws. Concerning thoroughness in mental acquirements, Professor DeMorgan, of London University, gave the following advice to his students: “Whatever else you may do, some one subject you should thoroughly master for the purpose of giving the proper tone to the mind upon its regard to the use, province and limits of knowledge in general.”

5. The study of plants furnishes an unequalled recreation and tonic for the mind subject to the strain of exacting business or professional life. Some of the most enthusiastic and accomplished botanists that this country has produced were practical and successful physicians, bankers, merchants and housewives. This study is especially valuable for invalids and persons of delicate physical organization and those of sedentary employment. When conducted in a rational manner the study is carried on principally in the health-giving atmosphere of the grove and meadow.

6. The study of plant-life, by exhibiting a practically inexhaustible field for research, acts as a preventive of the surfeit and disgust with the world which too often overwhelms highly but unsymmetrically developed minds. The wholesome restraint which the habitual exercise of the observing faculty—a faculty powerfully stimulated by this study—places upon the imagina-

tion serves to check its vagrant wanderings. There are no "cranks" in the ranks of botany! It guards also against misuse of the too often "fatal gift of expression," which so frequently makes its possessor mistake words for things and assertions for facts. An instructive example of what an exclusively literary and metaphysical training may do for a highly gifted man is seen in the career of the late Thomas Carlyle. Some time before his death Mr. Carlyle, in reviewing his life-work, made the following melancholy confession: "For many years it has been one of my most constant regrets that no school-master of mine had a knowledge of natural science so far, at least, as to have taught me the names of the flowers and grasses that grow by the wayside, and of the winged and wingless neighbors, who in my walks are constantly greeting me with salutations which, as things are, I cannot return."

It would be an easy matter to extend this enumeration as far as the orthodox thirteen, but these will suffice.

Perhaps some one will exclaim, "Yes, it is no doubt a pleasant thing to know by its proper name each wayside flower and tree, but who can remember the barbarous and uncouth names of botany?" Well, if one cannot at first remember the Latin names applied to plants by scientific botanists and unscientific pedants one can let scientific botany alone until one has developed some skill in observing plants and discriminating one species from another. The need of a terminology more exact than the common vernacular will become apparent and by that time the student will have developed enthusiasm sufficient to enable him to memorize the botanical vocabulary. At the beginning it will serve just as well to use the common vernacular name or even invent names for one's self. The name is the least important thing one can learn about a plant, and it is not wise for the beginner to exhaust his time and patience in trying to choose the most proper of several possible and equally unintelligible names. Rather he should study the structure and details of different plants and seek to group them around common types, thus learning for himself the philosophy of the natural system. The

scientific name must be eventually learned, but the unavoidable difficulty involved in learning and memorizing the name will be less discouraging when the need of knowing the name is urgently felt. Our barbarous Latin nomenclature, which well might make Virgil or Tully turn in their graves, is the least admirable part of the science and ought not to be obtrusively thrust before beginners! The average beginner is dismayed when, upon opening for the first time his botanical text-book, he finds the initial chapters headed by such unpromising words as Phylotoxis, Estivation, Morphology, etc., etc. This verbal quagmire placed by pedantry before the entrance to the "fairy-land of science" has swallowed up more budding scientific enthusiasm than has of war-like zeal

" * * * that Serbonian bog
'Twixt Damiatra and Mount Cassius old,
Where armies whole have sunk."

Where the services of a competent teacher can be had the best way to begin the study of plants is to go into the field and study them upon their native soil. Where no such a teacher can be found—such teachers are scarce—recourse to books for guidance is inevitable. For young pupils, and older ones who are unfamiliar with Latin, the best book to begin with is Miss Youman's First Book in Botany. This will lead up to Gray's School and Field Book, but persons not likely to be discouraged by Latin words may begin with the latter book.

Much more useful than any book is the student's field outfit. This should include a good pocket magnifier having two lenses, a pocket-knife with a thin and sharp blade for slicing soft stems and ovaries, a couple of steel crochet needles for picking out small seeds, a garden trowel or a stout knife for digging up roots, and an air-tight tin box for preserving such specimens as may be wanted for further study at home.

It is not best to bother with drying plants for the formation of a herbarium until after the student has become well acquainted with all the species common to his locality. When that time comes he will want to procure new species for study, and these

can be best secured by exchanging with students in different parts of the country or of other countries. The names of persons willing to exchange specimens can be found in the Naturalist's Directory, published by Casino, Boston, or by inquiring of the botanist attached to any college or Experiment Station. The making of good specimens is an art that takes a deal of practice and care to learn, but the following directions will aid the beginner:

In collecting herbs not over three feet take the whole plant, root and branch. When taller than three feet cut off that much measuring from the top, and in addition dig up the root with such leaves as may be attached. Of shrubs and trees a twig with leaves and flowers will suffice, but a piece of the bark is often necessary to enable one to make out the species. For dryers use common straw wrapping paper in sheets 12 x 18 inches. Place wad, about one inch thick, between the layers of plants. Carefully spread out the leaves and see that the flowers are not covered by them before putting on the dryers. The dryers must be changed every twenty-four hours for the first three days, afterwards every two days until perfectly dry. For a press use lattice-work frames, which any one can make out of a few laths or narrow strips of board. Apply pressure by means of a stout cord or a trunk strap and keep the package in the sunshine or near a stove. The plants will dry out in about a week.

For more detailed instruction the student is referred to a little work, "The Plant Collector's Hand-book," by Professor W. W. Bailey, published by Cassino, price \$1. A pamphlet equally as good is Professor L. F. Ward's "Suggestions to Beginners in Botany," which may be had gratis by applying to the Secretary of the Smithsonian Institution at Washington, D. C.

The following works for reference and general reading can be recommended, and they should be taken up in the order here given, viz.:

- Gray's Manual of Botany of the Northern States.
- Chapman's Southern Flora.
- Local Catalogues of Plants.

Grant Allen's Colin Clouts Calendar.
 Grant Allen's Pedigrees of Flowers.
 Underwood's Ferns.
 DeCandolle's Origins of Cultivated Plants.
 Mehan's Wayside Flowers.
 Goodale's Physiological Botany.
 Sach's Lectures on Plant Physiology.
 Darwin's Botanical Works.
 LeMaout & DeCaisne's General Botany, English Edition.

The *Botanical Gazette*, a monthly magazine published at Crawfordsville, Indiana, will be found very interesting reading after the student has mastered the rudiments of the science.

RECORDS OF MEETINGS.

REPORT OF RECORDING SECRETARY.

FORTY-FIRST MEETING.

STATED MEETING.

PERSON HALL, January 8, 1889.

Vice-President Graves presided. The following papers were read:

1. Report on Progress in Geology. Prof. Holmes gave an account of the efforts made at a unification of Symbols and Nomenclature.
2. Report on Progress in Physics and Engineering. In this Report Prof. Gore described the recent applications of Electricity to Street Railways.
3. An Historical Sketch of Mathematical Training in the University of North Carolina. This paper, by Prof. Love, besides containing a list of the instructors in mathematics and the text-books used during the century of the University's history just closing, outlined so far as possible the requirements for entrance and for graduation.
4. History of Mathematics in the Middle Ages. Prof. Graves continued, in this, his Early Mathematical History.
5. Early Legislation against Food Adulteration. Prof. Venable gave an account of some of the adulterations of food practiced in early times, the methods of testing for the same, and extracts from the old laws prohibiting and punishing such adulterations.

The Secretary exhibited the watch of Rev. Dr. Mitchell, which was worn by him when he met his death, and whose stopping was supposed to point to the exact hour of his fate. This watch has been presented to the Society by Rev. Mr. Summerell, the grandson of Dr. Mitchell.

The Secretary reported three additional exchanges and eighty-seven books and pamphlets received.

Messrs. A. H. Patterson and W. S. Roberson were received as associate members.

FORTY-SECOND MEETING.

STATED MEETING.

PERSON HALL, February 12, 1889.

As the Vice-President was absent, Prof. Gore presided. The papers presented were as follows:

6. Preservation of Wood with Creosote Oil. This paper, by Mr. I. H. Manning, appears in full in this issue of the Journal.

7. Natural History of the Cereals. Gerald McCarthy, Esq., gave in this paper a short account of each of the principal Cereals, giving not only the natural history but the story of their introduction, in a brief form.

8. Some Sources for Sugar Proposed at the Close of Last Century. Mr. H. L. Harris showed in this paper that many vegetables and trees had been closely examined with a view to their sugar-producing power, thus anticipating much of the similar work done of late years.

9. An Account of an Interesting Fossil found in the Neighborhood of Chapel Hill. Prof. Holmes exhibited fragments of this fossil recently dug up in this vicinity and gave an account of its discovery. He hopes soon to present a more complete paper upon the subject.

10. Note on the Decomposition of Nickel and Cobalt.

Dr. Venable read to the Society an abstract of the important paper by Kruss & Schmidt on this subject.

The Secretary reported two new members:

Prof. W. H. Pegram, Trinity College, N. C.

J. R. Harris, Esq., Experiment Station, Raleigh, N. C.

Several additional exchanges were reported. Eighty-five books and pamphlets were received during the month.

FORTY-THIRD MEETING.

STATED MEETING.

PERSON HALL, March 12, 1889.

Prof. Gore presided in the absence of Vice-President Graves.

The following papers were presented:

11. The Three Formations of the Atlantic Slope, with exhibition of photographs and specimens, by Professor Holmes.

12. A Note on the Use of Pulverized Coal as Fuel. By Prof. J. W. Gore.

13. A Photographic Camera made from a Cigar-Box, with an exhibition of views taken with it, by Mr. H. L. Harris.

14. Some Notes on Recent Progress in Chemistry. Dr. Venable described work done on preparing Artificial Quinine and Cocaine and gave some of the new applications of Cotton Seed Oil.

The Secretary reported as a new associate member Mr. C. W. Toms.

Twelve additional exchanges were announced and eighty-seven books and pamphlets received during the month.

FORTY-FOURTH MEETING.

STATED MEETING.

PERSON HALL, April 2, 1889.

Prof. Holmes presided in the absence of Prof. Graves, the Resident Vice-President. The papers presented were as follows:

15. A Primitive Reaping Machine. Prof. Alexander gave an account of this machine described by Palladius, a Roman writer on Agriculture, as in use among the ancient Gauls.

16. The Consumption and Waste of the World's Resources. Dr. Venable called attention in this paper to the rapid consumption of the world's available supply of coal and petroleum, and of the great waste of many valuable metals.

17. Prof. Holmes gave a paper on the use of the microscope in Geology and Mineralogy, in which were described several forms of microscopes, and particularly the one recently manufactured for the University by the Bausch & Lomb Optical Company, of Rochester, N. Y.

The Secretary reported three additional exchanges and seventy-five books and pamphlets received.

FORTY-FIFTH MEETING.

ANNUAL MEETING.

May 4, 1889.

In the absence of the Secretary and Treasurer, and because of the illness of the Vice-President, no reports were received from these officers.

The following officers were elected for the ensuing year:

President H. T. BAHNSON, M. D. Salem.
Vice-President H. B. BATTLE, PH. D. Raleigh.
Resident Vice-President J. A. HOLMES, B. SC. Chapel Hill.
Corresponding Sec. and Treas. F. P. VENABLE, PH. D. Chapel Hill.
Recording Sec. and Librarian J. W. GORE, C. AND M. E. Chapel Hill.

JOURNAL

OF THE

ELISHA MITCHELL SCIENTIFIC SOCIETY,

VOLUME VI—PART SECOND.

JULY—DECEMBER.

1889.

PERMANENT SECRETARY:

F. P. VENABLE, . . . CHAPEL HILL, N. C.

E. M. UZZELL, STEAM PRINTER AND BINDER.

RALEIGH, N. C.

1890.

OFFICERS.

1889-1890.

PRESIDENT :

H. T. BAHNSON, M. D., Salem, N. C.

VICE-PRESIDENT :

H. B. BATTLE, PH. D., Raleigh, N. C.

RESIDENT VICE-PRESIDENT :

J. A. HOLMES, B. AGR., Chapel Hill, N. C.

PERMANENT SECRETARY AND TREASURER :

F. P. VENABLE, PH. D., F. C. S., Chapel Hill, N. C.

RECORDING SECRETARY AND LIBRARIAN :

J. W. GORE, C. E., Chapel Hill, N. C.

LIBRARY AND PLACE OF MEETING :

CHAPEL HILL, N. C.

TABLE OF CONTENTS.

	PAGE.
List of Officers.....	42
Addendum to the Minerals and Mineral Localities of North Carolina. William Earl Hidden.....	45
Nematode Root-galls. Geo. F. Atkinson.....	81
A Tube-building Spider. Notes on the Architectural and Feeding Habits of <i>Atypus Niger</i> Hentz (?). W. L. Poteat.....	134
Records of Meetings.....	147
Report of Secretary for 1889.....	150
Report of Treasurer for 1889.....	150
Necrology.....	151
List of Members.....	152
List of Exchanges.....	155

Eight plates and thirty-eight figures in the text.

JOURNAL

OF THE

Elisha Mitchell Scientific Society.

ADDENDUM

TO THE

MINERALS AND MINERAL LOCALITIES OF NORTH CAROLINA.

BY WILLIAM EARL HIDDEN.

INTRODUCTORY NOTE.

At the suggestion of the acting State Geologist, herewith are appended some of the results coming out of my search for Platinum in this State in 1879. The trip was made in the interest of Thomas A. Edison, the famous electrician and inventor. My trip extended over five months, and the principal gold placers of North Carolina were visited. At the many places where I operated I did not find any traces of its existence. The five reported localities in North Carolina were carefully prospected without success. While examining these gold gravels for Platinum crystals of minerals having rare scientific interest would occasionally be noticed in my pannings.

The Brindletown district of Burke county proved to offer the greatest attraction in this connection. From a doubtful dozen, known to exist there before my visit, the list of occurring mineral species soon reached the goodly number of forty-five. Some of this list were new to the State, viz.: Octahedrite, Fergusonite, Malacon, Xenotime and Native-tellurium. Of greater interest was the observation of immense quantities of mona-

zite (now promising to become an ore of commerce for the thorium and cerium earths it contains) discovered to be stored away in the ravines and "placers" of this region.

My shipment to Mr. Edison, in 1879, of fifty pounds of a sixty per cent. monazite-sand was the starting of an industry which, in 1888, witnessed some twelve thousand pounds of a similar monazite-sand being sent out of the same region, and this business is as yet only in its beginning.

From my several notices of North Carolina minerals, published in scientific magazines and elsewhere, I condense into the following pages such matter as seems to be of interest for this report, additional to "The Minerals and Mineral Localities of North Carolina" (Chapter 1, volume 2, of the Geology of North Carolina, 1881, by Genth and Kerr).

DIAMOND.—A crystal,* weighing $4\frac{1}{3}$ carats, that would afford a gem worth intrinsically not over \$150, was found on the Bright farm, near Dysartsville, McDowell county, in the summer of 1886. It measured 10×7 millimeters and was a distorted octahedron. It was nearly perfect and of a grayish-green tint. It bears the distinction of being the largest and most valuable diamond yet found in the State.

Another diamond (not before publicly announced) was found in 1877, by a small boy, in the same region as the one above mentioned. It weighed $2\frac{3}{8}$ carats, was shaped very much like a smooth flat field-bean and was very well polished naturally. It was white, but somewhat flawed. The crystal planes were very obscure. The finder disposed of it in Marion for a mere nominal sum. Mr. B. B. Price, of Marion, put it into the hands of Mr. James M. Gere, of Spruce Pine, to dispose of to best advantage. Mr. Gere, who is an extensive buyer and miner of North Carolina mica, took it with him to Syracuse, N. Y., and sold it there to Messrs. C. M. Ball & Co., the leading jewelers, for the sum of \$18. It was finally sent to New York, where it was cut into a small gem and its identity lost.

*Am. Jour. Sci., Dec., 1887, p. 490, Kunz.

EMERALD (chrome-green beryl).—In the last edition (chapter 1, of the 2d volume, Geology of North Carolina) the discovery of emeralds in this State was only conjectured. Up to 1881 there had been found at the now famous locality only a few crystals, which “had not sufficient depth of color or transparency to be termed gems.”* But as forerunners of what followed in the succeeding years these crystals had their peculiar value as pioneer specimens presaging the existence of true emeralds. On page 41, chapter 1, Geology of North Carolina, 1881, the remark is made that “deep green crystals (of beryl) resembling emeralds and beautiful varieties, similar to occurrences in Siberia, are found on J. W. Warren’s farm, near Salem Church, Alexander county.”

The discovery of the emerald mine was made in 1880 and was in the nature of a scientific deduction from events occurring to me while carrying forward a systematic search for Platinum in North Carolina. While visiting Alexander county and vicinity, in 1879, a few pieces of “beryl” were noticed in the collection of a local mineralist (Mr. J. A. D. Stephenson) which in their edges exhibited a tinge of color verging distinctly on that of the emerald. On that observation I at once concluded that, a region which could produce beryls, having a slight tint of the true emerald color, might, or ought to furnish the *true emerald* if proper search was made. Accordingly, at my first leisure the locality was re-visited (the Warren farm above cited) and a systematic search commenced for the source of the crystals of beryl, which up to that time had only been found loose in the surface soil and of trifling value. After five weeks of fruitless effort a vein was found at a depth of eight feet below the surface, in which not only true emeralds were found, but also, along with them, many slender crystals having emerald color, perfect transparency, but otherwise very different from emeralds proper.† It is unnecessary to recount here all the emerald discoveries made in Sharpe’s Township, Alexander county, during

*Letter from Dr. Genth, 1880, to Mr. J. A. D. Stephenson.

†These crystals were subsequently given the name of hiddenite.

the past six years, and it must suffice to mention only the more important "finds."

In October, 1882, twenty-two ounces of emerald were found in one "pocket," one crystal of which was sold in its natural condition for \$800. (It weighed nine ounces and was eight and a half inches long and only partially suitable for jewelry).* Many "pockets" were found in the succeeding four years yielding crystals which sold for from \$25 to \$200 each.

On the ninth of August, 1886, a "pocket" was unexpectedly discovered which yielded another nine-ounce emerald; this crystal was one and one-quarter inches thick and three inches long, and is the largest of the three emeralds figured in Plate 1.

Nine crystals were taken out of this pocket at a depth of not over twenty feet. Three of them brought \$1,000 and are yet retained in their natural condition as when found.

In July (1886), at a depth of forty-three feet, in the hard rock, a small "pocket" was found and an emerald was taken therefrom which, upon being cut by a lapidary, yielded a beautiful gem of $4\frac{5}{8}$ carats weight and was worth \$200. It has the distinction of being the finest gem emerald yet discovered in the United States. This mine is owned by several Northern gentlemen and is incorporated under the title of "The Emerald and Hiddenite Mining Company," with a nominal capital of \$200,000. The locality is situated sixteen miles north-west of Statesville and directly on the line of the Taylorsville extension of the Western North Carolina Railroad. A station near the mine has been formally named "Hiddenite," and a new post-office has been established there, bearing the same name.

The photo-engraved Plate No. 1 exhibits well the natural form of three of the best crystals of the "find" of August, 1886, and also the shape of the cut emerald, all of natural size. The two crystals in the middle foreground are hiddenites, and will be noted under that head.

One-third of a mile due west a new discovery was made, in

*See Harper's Monthly Magazine, December, 1887, for colored illustration.

CRYSTALS OF
EMERALD AND HIDDENITE,
FOUND IN AUGUST, 1886.
Photo-engraved from Nature.

PLATE I.



PLATE I—A PART OF THE "FIND" OF AUGUST, 1886. (NATURAL SIZE).



1885, of emerald tinted beryls,* and the locality promises gem results in the near future. It is known as the Morton mine

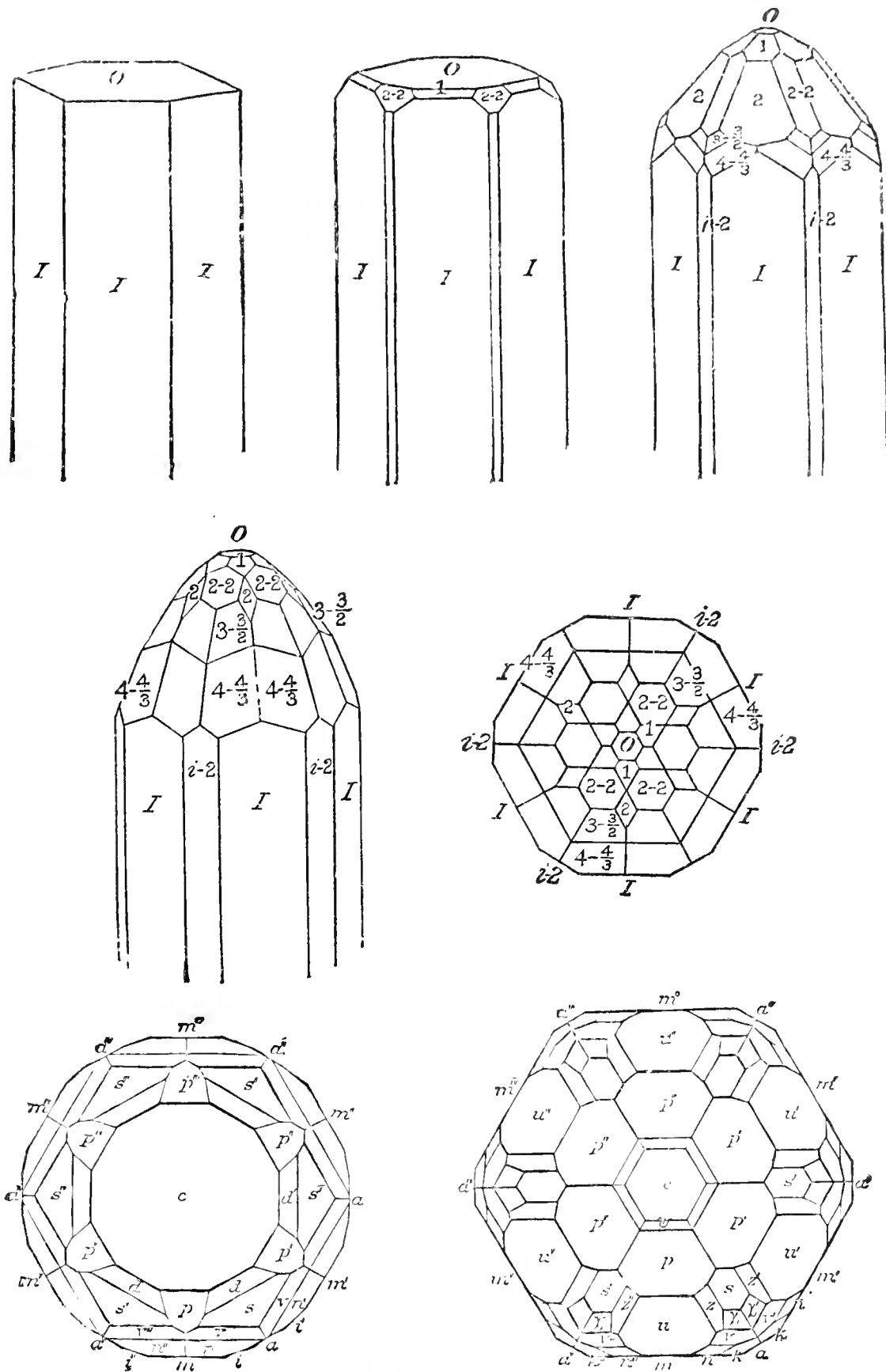

PLATE 2—BERYLS AND EMERALDS, FROM ALEXANDER COUNTY.

(formerly the Pendergrass-Lyon land). Good indications also exist, some three miles easterly, on the old Miller farm.

*It is stated on good authority that a Mr. Meisermohr found "a very green beryl" on this tract over twenty years ago.

In the writer's opinion emeralds will be found on the same geological horizon as the Alexander county localities over a very extensive area north-east and south-west. Outside of this emerald locality there is no other emerald mine known to exist in the United States.

BERYL (aquamarine and those varieties other than emerald).—Some notable transparent beryls were mined in Alexander, Macon and Yancey counties during the past five years, some of which were cut into brilliant gems of marketable sizes. As high as five dollars per carat has been obtained for large lots of North Carolina aquamarines of pale green, blue and yellow shades.

Those found outside of Alexander county were from the mica mines, while the former were exclusively from the gem mine in Alexander county, with one very remarkable exception of a huge gem beryl, from a new locality north-west from Taylorsville, where it was found loose in the surface soil.

Some of them are exceedingly beautiful in their natural condition as found, the polish on the natural crystal planes being equal to that made by a lapidary. See Plate 2, page 49.

Some few of the Alexander county crystals have from forty to ninety terminal faces* and would take rank, in a scientific sense, above those of any other American locality. Thus far eighteen different forms (three of them *new*) have been identified on the beryls found at the Emerald and Hiddenite mine, while commonly only two or three forms occur.

Opaque beryls, blue and green, weighing more than fifty pounds each, have been found in Yancey and Mitchell counties, and should glucina ever be desired in quantity, for commercial purposes, North Carolina could supply this ore of it, by the ton.

HIDDENITE† (emerald-green spodumene).—The manner in which this beautiful mineral was so unexpectedly discovered‡ has

*Amer. Jour. Sci., Nov., 1882, p. 372; *Ib.*, June, 1887, pp. 505—506. Sitzungsberichte der Niederrheinischen Gesellschaft für Natur- und Heilkunde in Bonn, July 7, 1886, pp. 90—93.

†Amer. Jour. Sci., Feb., 1881, pp. 128—130, J. Lawrence Smith.

‡A few pale, yellowish-green crystals of what, in 1879, was considered to be DIOPSIDE had been found on this same property by some of Mr. Warren's children, and they found their way into the local collection of Mr. J. A. D. Stephenson, in whose cabinet I noticed them (in 1879). Neither he nor I looked forward to finding this mineral of such a beautiful rich green color as was so unexpectedly done in the vein already mentioned, or of even finding it again. We did not, in fact, give it much attention. EMERALDS were the only goal ahead.

already been detailed in the preceding pages, under the head of Emerald. As early as November, 1880, I had shown this new emerald-green variety to possess the characteristics that are considered necessary in a gem stone, *i. e.*, beauty, hardness, trans-

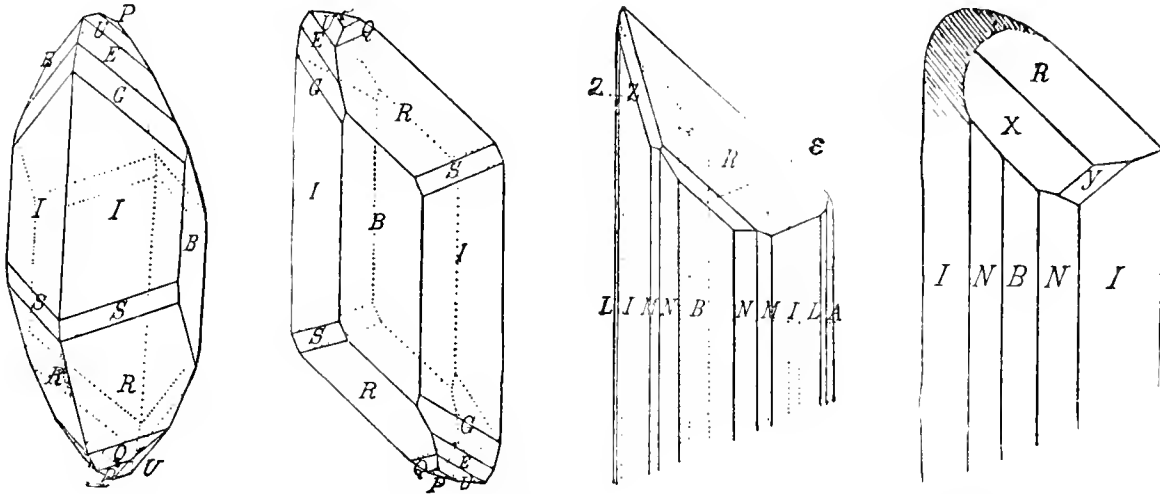

CRYSTALS OF HIDDENITE, FIGURED BY E. S. DANA.

parency and rarity. It did not take long, therefore, for this new gem to be appreciated on its own merits and find sale as a precious stone. Almost at once sales were made at the high rate of \$100 per carat, and within a year from its discovery it had been successfully introduced, both at home and abroad, as a gem of the highest rank. Hiddenite is to the species spodumene

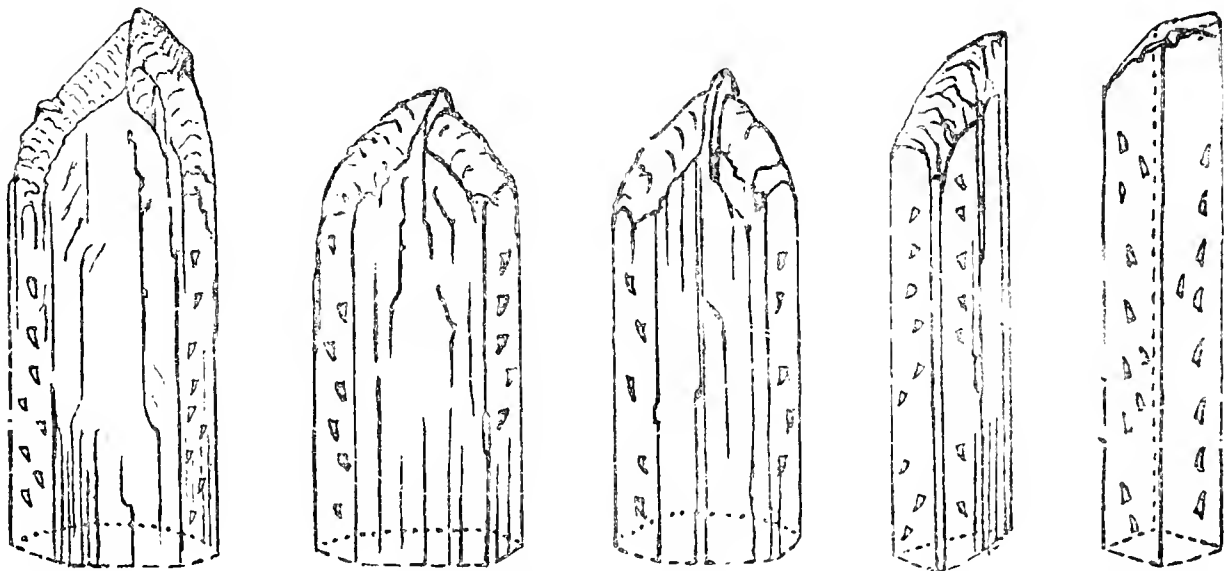

CRYSTALS OF HIDDENITE SHOWING TWINNING, AND ROUNDED TERMINATIONS DUE TO NATURAL ETCHING. (DRAWN FROM NATURE).

exactly what emerald is to the species beryl, *i. e.*, a chrome green variety. Its hardness nearly equals the emerald. Its density varies from 3.15 to 3.19. Its form is monoclinic, and the crys-

tals of this variety of spodumene have added nineteen new planes* to the species. Its cleavage angle = $86^{\circ} 46' 37\frac{1}{2}''$.

Careful analyses by Smith and Genth yielded the following results:

	<i>Smith.</i>	<i>Genth.</i>
Silica,	64.35	63.95
Alumina,	28.10	26.58
Chromic oxide,	0.00	0.18
Ferric oxide,25
Ferrous oxide,	1.11
Lithia,	7.05	6.82
Potash,	0.07
Soda,50	1.54
Loss, by heating,	.15
	<hr style="width: 50%; margin: 0 auto;"/> 100.40	<hr style="width: 50%; margin: 0 auto;"/> 100.25

To-day fine examples of this gem are quite the rarest among precious stones, and the demand was never supplied for the better sizes. "Owing to the dichroism there is a peculiar fire to them which is wanting in the true emerald."—Dr. E. S. Dana, *Am. Jour. Sci.*, Sept., 1881, p. 182. "It is a variety (of spodumene) rivaling the emerald as a gem," states Prof. J. D. Dana in his *Manual of Mineralogy* (1887), p. 269.

Plate 1 includes two crystals of Hiddenite [the two in the front middle foreground with their points extended towards the reader.] The larger crystal is the finest one yet discovered. It was 68 millimeters long and 7×14 thick. It would furnish two gems weighing over five carats each, one of which would be of superb dark-green color. Up to the discovery of this crystal (which is now in the Bement collection) the largest cut gem weighed but $2\frac{5}{8}$ carats, and it had been sold to a wholesale gem broker in 1880 at the rate of \$100 per carat.

The work of development at the mine has reached a depth of fifty-eight feet, thirty-two feet of which is in the solid rock. The formation continues unchanged, and the last work done yielded a handsome percentage of profit.

SPODUMENE (other than the emerald-green variety).—The ordinary common variety of opaque gray spodumene has not as

*Described by Dr. E. S. Dana and the late Prof. G. Vom Rath.

yet been found in North Carolina. Perfectly clear crystals of faint yellow tints and different shades of yellowish-green have been found at the emerald locality, and fine gems have been cut of these pale colors which were very brilliant. Often a crystal of spodumene will be almost colorless or faintly yellowish for three-fourths its length and then terminate with a crown of pure emerald color. This phenomenon is peculiar, but not confined to spodumene; for some tourmalines, sapphires, sphenes, etc., show a similar diverse arrangement of coloring matter in the same crystal.

Pseudomorphs of pinite, museovite and "gillingite" after spodumene crystals occur at the Alexander county locality much the same, though in miniature, as those at Branchville, Conn., and elsewhere. The Alexander county spodumene, thus far in my experience, is an implanted mineral on the walls of open pockets and is not an imbedded mineral as is the fact elsewhere in the United States. This may explain its gem character in North Carolina.

GARNET (pyrope and almandine varieties).—Some very creditable gems of brownish-red, cherry-red and purplish-red hues have been found in Alexander county, though no regular deposits have been located as yet. A few of the cut stones sold for from \$3 to \$10 each. One four carat gem brought \$20.

The locality eight miles south-east of Morganton has produced several tons of a very compact and perfect garnet, which have been crushed into different grades of fineness for use as a "sand-paper" and shipped in that form to Northern parties.

[The locality stated as "Marshall's farm, where garnets are found two feet in diameter," seems to be erroneous. People in Alexander county cannot locate it, and the size stated seems too great.]

ZIRCON (silicate of zirconia).—The locality on Green River, Henderson county, at the old Freeman place, has been re-opened, and the yield to date has been upwards of twenty tons (40,000 pounds). This and the adjoining Jones mine have produced about thirty tons altogether, most of which has passed through

the writer's hands to its ultimate market. Under encouragement from General T. L. Clingman, these same mines had produced, up to 1879, not far from a ton of pure zircons. This industry is an entirely new one. North Carolina has natural advantages in her zircon mines in the method of their occurrence, which permits her to successfully compete with the whole world in their production. Zirconia is the most infusible substance known (with the possible exception of thoria), and these North Carolina crystals contain 65.3 per cent. (Chandler) of zirconium-oxide. The use to which this unprecedented quantity of zircons is being put, is as one of the constituents in the make-up of the lately patented Welsbach Incandescent Gas-light. The inventor is Dr. Carl Auer von Welsbach, of Germany, who is now making practical use of the incandescence of zirconia and other rare earths (ceria, lanthana, thoria, etc.) while under high temperatures. The best results are obtained when water or natural gas is used, since the heat obtained is much greater than from ordinary gas. Already strong companies are being formed the world over to introduce and maintain this new gas-light, and it promises to become a very popular means of illumination.

ALLANITE.—Several new localities of this rare mineral have been discovered. The one near Democrat Post-office, in Madison county, is very promising. The locality near Bethany Church, Iredell county, has been examined lately, and it is safe to assert that tons could be mined there. A variety in crystals from the Wiseman mica mine, Mitchell county, has been analyzed by Mallett and found to contain 8.20 per cent. of yttria and only 1.53 per cent. of ceria. This mineral has also been identified by the writer among specimens from Brindletown, Burke county; at the Henderson county zircon mines and at the gem mine in Alexander county.

PYROCHLORE.—I have found small crystals of this rare mineral (they may prove to be microlite) at Ray's mica mine, Yancey county, and better crystals, of the variety known as Hatchettolite, at Wiseman's mica mine, Mitchell county. The latter contains about 15 per cent. of uranium oxide.

COLUMBITE.—A single large crystal of this ore of columbic acid was found near Liberty Church, Alexander county. Its density was 6.28. It therefore consisted more largely of tantalic acid than is commonly found in columbite. The mineral thought to be *Æschynite*, now credited to this State, has been shown to belong here.

SAMARSKITE.—Several hundred pounds have been mined and sold during the past five years from the old original locality at Wiseman's, in Mitchell county. Several new earths have been discovered in it, *i. e.*, Decipia, Phillipia, Samaria, etc.

EUXENITE.—This species has not as yet been found in this State. The brown mineral from Wiseman's mine lacks the titanic acid essential and is only altered samarskite.

ÆSCHYNYTE AND YTTRO-TANTALITE.—These species have not as yet been identified from this State and should not be included in the list of North Carolina minerals.

POLYCRASE, or an allied species, has lately been found on the Davis land, in Henderson county, near Green River. It is a columbo-titanate of yttrium and uranium, and a qualitative analysis has shown *all* of these elements to be present. The proportion of the yttrium earths and of uranium seems to be higher than found in the Norwegian polycrase, and the columbic and titanic acids seem to be present as a complex inorganic acid and not as a mere mixture. It may be a new species.

RUTHERFORDITE.—A doubtful species long credited to this State. It is most probably identical with the fergusonite of the same region first recognized by me in 1879, and analyzed by Smith and Mallett.

FERGUSONITE (columbate of yttria, erbia, etc.).—I have found very fine crystals at the Wiseman mine, in Mitchell county, but with nothing new as to form. Some were more than one inch long. The locality about the Pilot Mountain, in Burke county (Mill's mine), has produced many crystals of this rare mineral.

XENOTIME (yttrium-phosphate).—Some few extraordinary crystals were found in Alexander county at a place about three miles east from the Emerald mine. At first they were not unnatu-

rally mistaken for zircons, such was their almost perfect resemblance in color and form. The best single crystal was only one-fourth inch wide and one-half inch long, though a polysynthetic grouping of several crystals was double that size. The particular feature was the long prismatic development (zircon-like) and the transparency of the crystals. Careful measurements showed the inclination of the unit pyramid on the prism to be $131^{\circ} 12'$ to $131^{\circ} 14'$. Density 4.52. They added one new plane to the species, the pyramid 3 (331). A notable crystal was .121 and .113 inch in its two diameters and .522 inch long. It was perfectly transparent and of a hair-brown color. A small mineralogical gem could have been cut from it.

Lately I have re-examined the monazite-sand obtained in August, 1880, near Milholland's Mill (now Warren's), on Third Creek, Alexander county, and have identified this rare mineral in it. The crystals are very minute, but are perfectly clear, have a delicate brown tint and have long prismatic development. They also present one *new* plane, *i. e.*, pyramid 2 of the second series. I have described crystals from Burke county* (Mills') and from Henderson county (Davis' on Green River) that were symmetrically compounded with zircon, like those from Norway first noticed by Zschau. (Amer. Jour. Sci., II, XX, 273).

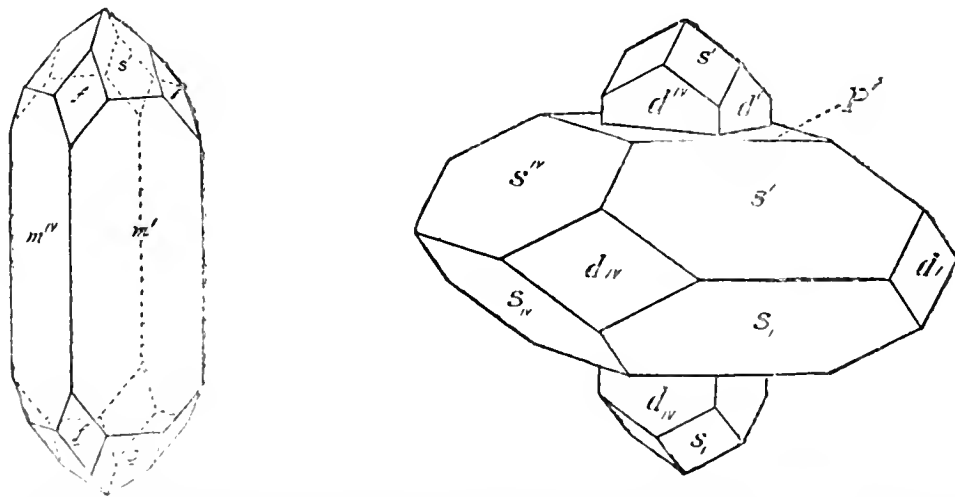

PRISMATIC XENOTIME AND XENOTIME-CYRTOLITE (SYMMETRICALLY COMBINED) FROM ALEXANDER AND HENDERSON COUNTIES.

MONAZITE (cerium, lanthanum and didymium phosphate with some thorium).—The crystals of this species which I was

*Lately found to contain over 4 per cent. of thoria.

privileged to discover in 1880, in Alexander county, at the then Milholland's Mill locality* proved to be the most perfectly developed crystals found up to that time, and in the hands of Dr. Edward S. Dana† have given the first wholly reliable results obtained for the species as to its angles. He found their axial ratio to be c (vert.): b : $a = 0.95484:1.03163:1$; with a (100) over c (001) = $76^\circ 20'$.

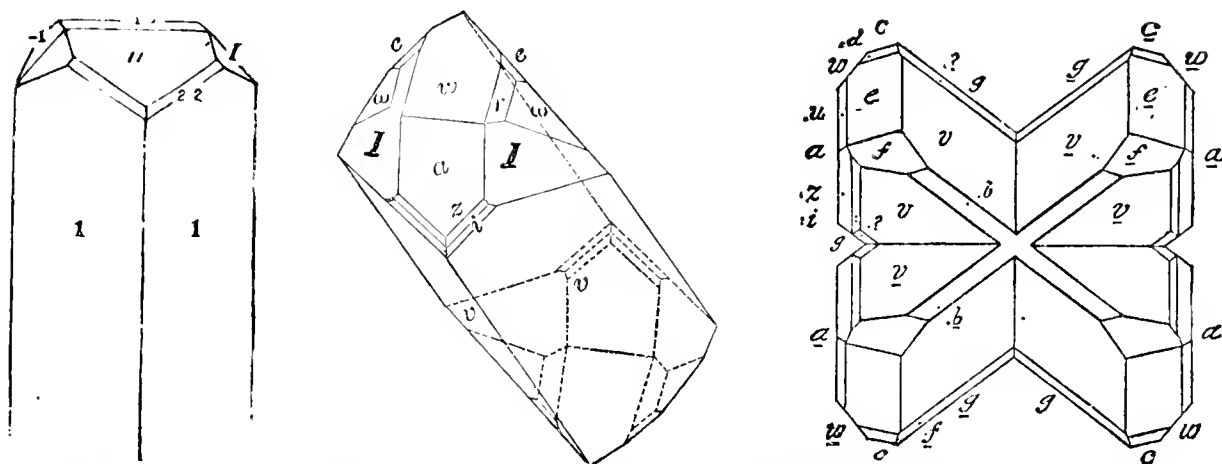

MONAZITE, PRISMATIC AND TWINNED, FROM ALEXANDER COUNTY.

They were highly modified, very brilliant in lustre, of a light topaz-yellow color and of perfect transparency. Many hundred were found, but mostly of minute sizes; those of one-eighth inch diameter were very rare. Nine different forms were identified and twelve in all were observed. The prismatic angle, I over I (110×110), was determined very exactly, *i. e.*, $93^\circ 25\frac{2}{3}'$. For the first time the true form of this species was removed from all doubt.

The monazite of the Pilot Mountain gold region (Burke county) has been carefully analyzed by S. A. Penfield,‡ of Yale College. He states that "almost half of the bulk of this sand (after careful concentration) is composed of resinous-looking grains of monazite, from $\frac{1}{16}$ th to $\frac{1}{8}$ th inch in diameter, some showing crystalline planes." By careful selection a sufficient quantity of the pure monazite, of an even shade of color, for a complete analysis in triplicate was finally separated. The specific gravity

*Am. Jour. Sci., July, 1881, p. 21.

†Ib., October, 1882, p. 247; *ib.*, pp. 250—252.

‡Ib., October, 1882, pp. 247—254, E. S. Dana and S. L. Penfield. "Zeitschrift für Kristallographie, etc.," 7, 363—365, Dana.

was found to be 5.10; the color usually varies from wax-yellow to cinnamon-brown.

The result was as follows:

	I.	II.	III.
Phosphoric acid, .	29.45 .	29.20 .	29.20
Cerium oxide, .	31.38 .	31.94 .	30.77
Lanthanum oxide, {	30.67 .	30.80 .	31.17
Didymium oxide, }			
Thorium oxide, .	6.68 .	6.24 .	6.56
Silica,	1.40		
Water, or loss by ignition, 0.20 .	0.20 .	.20 .	
	<hr/>		
	99.78		

It is thus seen that this particular monazite is a normal phosphate of the cerium metals, with a mechanical (?) mixture of a thorium silicate, very similar, chemically, to the symmetrical inclusion of zirconium-silicate (zircon) in the yttrium-phosphate (xenotime) found in this same region.

A monazite from Virginia yielded fourteen per cent., and a mass from Connecticut gave eight per cent., of thoria to this same analyst.

In the light of some recent inventions monazite-sand may become of considerable commercial value on account of its very apparent applicability. The *complete* separation of the grains of monazite from the other minerals composing the sand is the one "desideratum" necessary to insure its practical use on a large scale.

Mineralogists and crystallographers have been especially pleased with the "find" of monazite crystals at a locality in Alexander county situated about three miles east of the Emerald and Hiddenite mine. They were found among large smoky quartz crystals, considerable rutile in the form of fine yellow needles matted together and some remarkable xenotimes. Only about twenty good crystals were found. For the most part they were transparent, of a beautiful esonite-red color and highly polished. They varied in width from one-fourth to one-half inch, and from one-third to three-fourths inch long. They were long-prismatic in the direction of the clino-axis and

were twinned parallel to the orthopinacoid. Cruciform twins like the figure were observed.

In the respects of size, color, being twinned and in the occurrence of several planes, they differed from those found at Millholland's Mill, in the same county, but they were not quite as smoothly and perfectly developed. An analysis, by Penfield, showed only a normal monazite with 1.48 per cent. of thoria as impurity (?). Specific gravity, 5.203. Nothing finer, in this species, has as yet been discovered over the entire world.

APATITE (phosphate of lime).—This species is rare in this State, as a crystallized mineral. Excepting at the Ray mica mine, in Yancey county, where crystals were found one-half to two inches thick, having a gray color, I do not remember to have noticed any evidences of its occurrence outside of Alexander county. The discovery of fine crystals in this State is notable only from its scientific value, since the crystals were small and quite rare.

In many of the gem bearing "pockets" opened-out in Sharpe's Township, Alexander county, small apatite crystals have been found, but not until July, 1886, were any found that were worthy of particular notice. In a "pocket" $10 \times 2 \times 6$ feet (which was found forty feet below the surface) among splendid crystallizations of quartz, muscovite, siderite, dolomite, rutile and emerald, several patches of apatite crystals were noticed. It was plainly evident from their loose attachment and perfection that they were the last crystallization of the "pocket." For the most part they were rather long, slender, six-sided prisms of a pale bluish-green color and transparent. Few were more than one inch long. They were undistinguishable from beryls in their appearance, though beryls rarely occur so brilliant and perfect in outward form. In one corner of the pocket a small group of muscovite crystals were found on which were implanted a few very brilliant wine-yellow transparent crystals of apatite. They were of an entirely different habit from the other apatites

found. Instead of being long prismatic they presented mostly terminal planes in great number, as the two figures here show.

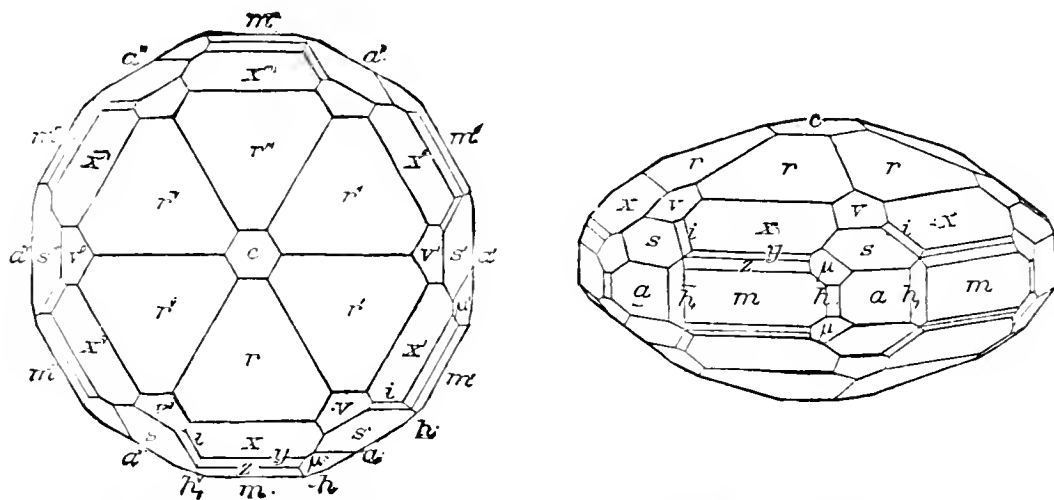

HIGHLY MODIFIED APATITE CRYSTAL, FROM ALEXANDER COUNTY;
FIGURED BY H. S. WASHINGTON.

Fourteen different forms were identified, twelve of which appear in the above figure. A normal development would present one hundred and thirty-four planes on each crystal, while only twenty planes are found ordinarily on apatite.

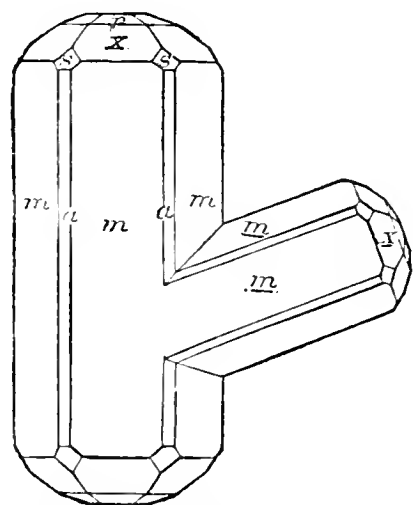

TWIN OF APATITE,
ALEXANDER Co.

The angle of the base c (0001) on the unit pyramid x (1011) was found to be $139^\circ 44\frac{1}{2}'$ and the axial ratio as $1 : 0.734335$.*

A twin crystal of apatite, the first to be described† and credited to the species, is here figured. It was found with the slender crystals above noted. The twinning plane was discovered to be s (1121, 2-2).

Excepting the green and purple apatite from Mt. Auburn, Maine, none has been found in the United States more highly interesting or more beautiful.

RUTILE (pure titanitic acid, $Ti O_2$).—This mineral is not used to any great extent commercially, and no very large deposits have been found in this State, but it has been proved to have a very general distribution throughout the Piedmont belt and to

*Am. Jour. Sci., June, 1887, p. 504, Hidden and Washington. †Ibid.

occur frequently in magnificent crystallizations. Crystals of considerable magnitude have been found in Clay county, Yancey county (near Hurricane Mt.), in Michell county (near Bakersville) and in many localities in Burke, Iredell and Alexander counties. Notable quantities have come from Clay and Cherokee counties, and from Lincoln county, near Lincolnton. To Alexander county, however, the credit must be given of having produced the most beautiful rutile crystals known to science. Rutile is found there in a similar situation to the gems and quartz crystals, *i. e.*, in open pockets; in fact, it is found intimately associated with and implanted upon the gems and often preponderates over all the other crystal contents. The particular points of difference over the same product from other regions are their mode of occurrence, beautiful natural polish and crystallographic features. Their color ranges from jet black to clear ruby-red and pale-yellow. They range from those of minute sizes to rare examples three inches long and half inch diameter. Their lustre in some cases approaches that of polished steel. Gems have been cut from the most solid crystals and the result compares favorably with the rare black diamonds from Brazil. Only experts could tell them apart.

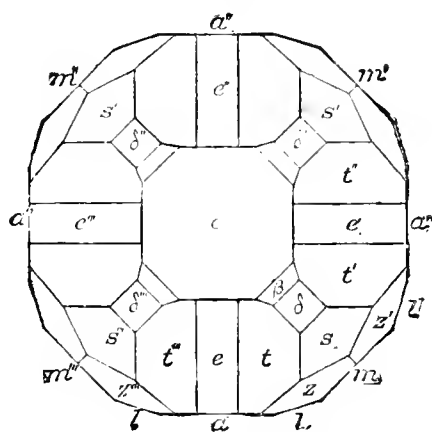

HIGHLY-MODIFIED RUTILE.
(BASAL VIEW).

The axial ratio was determined anew on these crystals, and measurements of the angles gave results remarkable for their close agreement to the calculated angles.* Five new planes were also added to the species, four of which were discovered on two crystals found by the author in Sharpe's Township, Alexander county, at the Emerald mine.

Curiously jointed, mitred and reticulated crystals and also masses of crystals thus united have been commonly met with; all of which are found to follow certain arbitrary twinning laws

*C over s (0001, O over 111, 1) = $137^{\circ} 39' 52''$. $a : c = 1 : 0.644252$, Washington.

and are not accidentally brought together into such strange shapes as a cursory examination might seem to indicate.

TOURMALINE.—Some fine black crystals have been found in Alexander county, at the gem mine, and as their forms have been closely inspected, and their composition ascertained, they are worthy of notice here.

The largest crystals of this “find” were not quite three inches long, but unlike the commonly occurring tourmalines they were never imbedded in a matrix. Thin sections and splinters show a deep brown color. The faces were highly polished, especially the terminal planes, and twelve different forms were identified. One new plane was found, *i. e.*, $\frac{2}{5}$ R. The angle of $\frac{1}{2}$ R over $\frac{1}{2}$ R (1012 over 1102) was ascertained to be $132^{\circ} 58\frac{1}{4}'$.* (Des Cloizeaux obtained $133^{\circ} 08'$ on foreign crystals). The basal plane was frequently observed.

A careful analysis by R. B. Riggs,† U. S. Geological Survey, gave the following results:

Sp. Gravity = 3.13.

Silica,	35.56
Alumina,	33.38
Ferrous oxide,	8.49
Titanic acid,	0.55
Manganous oxide,	0.04
Lime,	0.53
Magnesia,	5.44
Soda,	2.16
Potash,	0.24
Water,	3.63
Boracic acid,	10.40
						<hr/> 100.42

A few green tourmalines associated with lepidolite (or a pink mica) have been found near Burnsville, Yancey county, which possibly indicates that the gem variety may be found there ultimately.

MALACON.—In the Brindletown gold sands I have found several good crystals of this rare variety of zircon. The color

*Measured by H. S. Washington.

†Amer. Jour. Sci., Jan., 1888, p. 45, Riggs.

is jet black with occasionally a grayish crust. The form differs from the zircons directly associated with them, and they are also very much larger. Their black *glassy* fracture distinguishes them from the fergusonite and samarskite of the same sands. Their density equals 4.087.

CYRTOLITE (Hydrous zirconium, etc., silicate).—Masses and distinct crystals having curved faces and gray-brown color have been met with at the Wiseman mica mine, in Mitchell county, associated with autunite, fergusonite and samarskite. Also at Mill's mine, near Brindletown, and at the xenotime and polycrase (?) locality on the Davis land, near Green River, in Henderson county.

THORITE (Hydrous thorium-silicate).—The discovery of thoria in the Burke county monazite* has led Penfield† to regard its presence as due to a mechanical mixture of thorite with monazite. Dunnington suggested substantially the same after an analysis of Virginia monazite.‡ Penfield states that “oxide of thorium is widely different, in its chemical relations, to the oxides of the cerium metals, and hence should not be present as a replacement of them; and moreover, as it is present in very different amounts, it seems natural to assume that the thoria exists in the form of an impurity.” Penfield has shown by a microscopic examination that thorite *is present* in monazite beyond question. He prepared a thin section which showed small grains of a darker resinous substance scattered through it. It was moistened with hydrochloric acid, gently warmed, then carefully washed with water and examined with the microscope. White blotches had taken the place of many of the resinous spots, while the monazite appeared to be wholly unattacked. This observation proved beyond doubt the (sometimes) inclusion of thorite in monazite and substantiated the chemical evidence (see analysis of monazite before noted).

Now that thorite is known to exist in this State microscopi-

*Edison found thoria in this mineral in 1879 in specimens collected by the writer.

†Am. Jour. Sci., October, 1882, p. 253. ‡Amer. Chem. Jour., IV, 138, 1882.

cally we may hope to find large masses of it, as is the case in Norway and Sweden.

I have had a considerable quantity of thoria and thorium salts prepared from the monazite-sand found in Burke county, near Brindletown, and I believe that the quantity there available would aggregate many thousand pounds, should a demand arise for its production.

AUERLITE.*—While about to complete a contract, furnishing twenty-six tons of zircons, this mineral was found in small quantity. I returned to the locality for more material and was obliged to mine four hundred pounds of zircons, additional, in order to get enough of this new mineral for analysis and description. Thus far I have only had three ounces of it, but believe that in the neighborhood of its discovery some notable deposits of this rich ore of thoria and of thorite or orangite will be discovered. It has only been found at the well-known Freeman zircon mine, in Henderson county (on Green River) and on the Price land, three miles south-west. At both places it occurs in disintegrated granitic and gneissic rocks, and has been found after the manner of gold-washing.

Its specific gravity varies from 4.4 to 4.766, the darker colored mineral being the densest. Its hardness = 2.5 to 3. It is very brittle and is easily crumbled. Color, from pale lemon-yellow to orange and brown-red. Forms are like the zircons of the region, only they have a tendency to a longer prismatic development. The crystals are often found attached to unaltered zircons in parallel position. One twin crystal was found having twinning plane parallel to 1-*i*, like zircon twins.

Analyses (by Mackintosh) show it to be either a hydrated thorium-phosphate mixed with a hydrated thorium-silicate, or a partial replacement of silica, in thorite, by phosphoric acid. Its composition has a direct bearing upon the presence of thoria in monazite (q. v.) and seems to prove that thoria can be considered as partially present in monazite as a phosphate. The analyses gave the following results:

*Am. Jour. Sci., Dec., 1888, pp. 461—463, Hidden and Mackintosh.

	I.	II.	III.
Water, . . .	9.88	11.21
Carbonic oxide, . . .	1.00		
Silica,	7.64	8.25
Phosphoric acid,	7.46	7.59
Thorium oxide,	70.13
Ferric oxide,	1.38
Lime,	0.49
Magnesia,	0.29
Alumina, etc.,	1.10
		99.70	

It is readily soluble in HCl. It turns dull-brown on ignition, but becomes orange again on cooling.

This occurrence of thoria, in combination with phosphoric acid, is the first instance of such a compound existing in nature. The analysis leads to the formula— $\text{Th O}_2 \left\{ \begin{array}{l} \text{Si O}_2 \\ \frac{1}{3} \text{P}_2\text{O}_5 \end{array} \right\} 2\text{H}_2\text{O}$. This mineral has been named auerlite, after Dr. Carl Auer von Welsbach, the inventor of the Welsbach Incandescent Gas Burner, for the reason that, it was found while mining the very large quantity of zircons ordered to supply a demand directly caused by his invention and but for which this mineral might not now be known.

TUNGSTEN.—A mineral, having a density of 7.2, has been found in Granville county, near Henderson. I have not as yet had enough of it to determine whether it is wolframite, hübnerite or megabasite. It was associated with magnetite and quartz and had been considered “a very rich iron ore” locally.

CASSITERITE (tin-stone, oxide of tin).—The full history of the finding of tin-ore in this State has never, to my knowledge, been given to the public.

It seems that a student* of the military school at King’s Mountain Station found a few pieces of an unusually heavy mineral somewhere in the village and took them to his home in Morganton. This happened sometime in 1882. In 1883, when specimens were eagerly sought for everywhere in the State for the American Exhibition held in Boston in October and November of that year, a little lot of minerals were gathered together in

*Robert T. Claywell, of Morganton.

Morganton by Colonel S. McD. Tate, and sent by him direct to Boston. Among this lot was included the specimens first mentioned.

The unpacking of this particular box came into my hands, and the contents were duly exposed in the cases of the North Carolina exhibit. The pieces of cassiterite were found wrapped in a paper and were without any label or mark to distinguish its identity or locality. At once I knew it to be cassiterite and so labeled it. (The "*Commercial Bulletin*," Boston, Mass., of October 13th, 1883, contains the following paragraph in a lengthy notice of the North Carolina mineral exhibit: "*Cassiterite*.—Pure tin-oxide. Found massive, and semi-crystallized, in the western part of North Carolina. Sp. Grav. 6.8; hardness 7; 70 per cent. tin"). I acquainted all the gentlemen of the North Carolina section with my identification of tin-ore among specimens sent from Burke county, and impressed upon them the possibilities which a proper location of the original source might bring about. For the time being I dismissed the matter from my mind, thinking that when opportunity offered I should investigate it myself. To our then State Chemist* and to the then Commissioner of Agriculture† I imparted my discovery, and they both expressed great surprise and pleasure that the rare mineral, *cassiterite*, was at last added to the State's resources. This was in October of 1883.

In February of the next year public announcement of the discovery of tin at King's Mountain, N. C., was made by Dr. Dabney, who gave the credit to the young student who had merely picked up the ore, and a tin excitement was the result. In all these notices no credit was given to the one who had first identified the mineral as tin ore and to whom the honor of the discovery was properly due under the rule of priority.

As the sequel proved the discovery prompted a considerable amount of work being done at the locality, with but meagre results in finding paying veins or workable masses of ore.

*Chas. W. Dabney. †Montford M. McGehee.

In point of fact (I state this from a later personal experience at the locality, in the interest of a New York gentleman, whereby \$500 was spent in fruitlessly prospecting for a tin mine) the tin-ore has only been found as yet in small pieces (fourteen ounces the largest), and no regular connected veins have been located. The ore seems to be nodular and sparsely disseminated over a very considerable area in and about King's Mountain village, and paying mines of tin ore in that region have yet to be discovered.

The ore is very pure, assaying often 68 per cent. of metallic tin, but it is very difficult (or has been) to get any very considerable quantity of the pure cassiterite together at one time from any one place. Altogether the total output of the locality might not aggregate over 500 pounds of pure cassiterite. For the present we must be content with the simple knowledge of its existence in our State, and the belief that paying tin mines will yet be discovered somewhere within her borders. I have thus shown how tin was first made known in North Carolina, how mines of it were eagerly looked for and how it all resulted—as I believe—*unprofitably* to all parties concerned. Let us hope that the next tin excitement will *rest* on a larger and more deep-seated foundation and not pounds, but tons, will express *the daily output*.

MUSCOVITE (mica).—Marketable mica has been found in small quantities in Alexander county, but the special discovery to be noted is *of crystals* of mica of rare perfection of form and of their occurrence in the open "pockets" at the gem mine in Alexander county. Hundreds of pounds are thrown away because of its small size, though surfaces four inches diameter and larger have been often found. The form is thin hexagonal, with many planes showing on the prismatic edges; but too obscure for identification or careful measurement. The color varies from brown to bright-green. It is with pleasure that I add an analysis, by F. W. Clarke* (U. S. Geol. Survey), of this interesting mica :

*Am. Jour. Sci., August, 1887, p. 131.

Water, loss on ignition,	5.46
Silica,	45.40
Titanic acid,	1.10
Alumina,	33.66
Ferric oxide,	2.36
Magnesia,	1.86
Lithia (trace),
Soda,	1.41
Potash,	8.33
Fluorine,69
	<hr/>
	100.27
Less oxygen,29
	<hr/>
	99.98

Associated with and upon it, were found thin scales of a mineral related to hisingerite; it may be "gillingite."

DOLOMITE.—Beautiful crystallizations, of this carbonate of magnesia and lime, occur with siderite (carbonate of iron) and calcite (carbonate of lime) in the gem-bearing pockets of the deeper workings in the Emerald and Hiddenite mine, in Alexander county. The crystals are remarkable for not presenting any curved faces and for their simplicity of form. The unit or cleavage rhombohedron is the common form, though four other planes have been observed. Twin crystals are common. Color, from clear glassy colorless to pale brown and purplish. White opaque crystals are also found. No finer crystals of dolomite have been discovered in the United States, and few, indeed, from European localities can compare with them.

Smooth polished crystals three inches in diameter were not uncommon. Outside of this Alexander county region no crystallized dolomite had been found before in this State, and only near the valley river in Cherokee county, as a marble-like variety, is its existence otherwise known in the State.

GAHNITE (zinc-spinel).—Dr. Genth has analyzed the fine green massive variety from the Grassy Creek mica mine, in Mitchell county, and found it to contain thirty-eight per cent. of the oxide of zinc, which is uncommonly high for the mineral. Considering its rarity and mode of occurrence the high per cent. of zinc found in it seems to have been discovered in a very odd and out-of-the-way place. No other zinc mineral is known to exist in the neighborhood or for many miles around.

METEORIC IRON.—A new mass of meteoric iron has been announced as found on the Linville Mountain.* It is small, weighs about one pound and is very much rusted. It has been analyzed by Whitfield with the following results:

Iron,	84.56
Nickel,	14.95
Cobalt,	0.33
Sulphur,	0.12
Carbon,	trace.
		99.96

A twenty-six pound mass of meteoric-iron has just been placed in the State Museum from Rockingham county, and it is considered to be a portion of the same meteorite of which, in 1866, Professor Kerr secured an eleven-pound mass in the same region.

METEORIC STONE.—The largest stone of the Nash county “fall” of May 14th, 1874, came into the writer’s possession in 1886. It weighs about twelve pounds. Dr. Sill (on whose land it was seen to fall) had carefully preserved it, and for twelve years he had refused to part with its possession to any one. It is the next largest meteoric *stone* known to have fallen in the State, that of Cabarrus county being somewhat heavier.

XANTHITANE† (a mineral resulting from the alteration of titanite).—It is found abounding in a disintegrated pegmatite near Green River Station, in Henderson county. Its color is yellow, of different shades. The form is that of titanite, though well preserved crystals are rare. Density 2.48—2.94.

An analysis by Mr. L. G. Eakins‡ (U. S. Geol. Survey) lately completed is here appended. It was made on air-dried material :

Water, lost at 100 degrees,	. 6.02	Unaltered titanite.
“ “ red heat,	. 9.92	30.61
Silica,	. 1.64	40.82
Titanic acid,	. 57.46
Alumina,	. 16.41	28.57
Ferric oxide,	. 4.16
Lime,	. .84
Magnesia (trace),
Phosphoric acid,	. 3.89	100.00
	100.34		

*Am. Jour. Sci., XXXVI, Oct., 1888, Kunz.

†Am. Jour. Sci., XXII, 96, 1856.

‡L. c., March 3, 1888, from F. W. Clarke.

As Clarke remarks, "The analysis shows a complete removal of lime and silica from the original sphene (titanite) and a taking up of alumina and water. The result is a clay containing titanium in place of silicon."

I believe this mineral could be mined profitably as an ore of titanitic acid.

QUARTZ.—Within the past twelve months masses of clear rock crystal, of sizes unprecedented in the United States, have been found near Jefferson, in Ashe county. Two of these (which were seen by the writer) would have furnished perfectly clear and flawless spheres of five inches in diameter, or pellucid slabs eight by six inches square. One large crystal weighed nearly two hundred pounds and had highly polished natural faces. Under the names of "Pebble" and "Rock-crystal" this kind of quartz finds ready sale, by the ton, for the purposes of furnishing material for spectacle lenses and for ornament. Mitchell and Alexander counties have also produced large masses.

Important discoveries of new and rare crystal forms, in this very common species, have been made on crystals from Alexander and Burke counties.* The late Professor Gerhard Vom Rath, of Bonn, Germany, has made our quartz crystals famous by his very patient labors in the identification of their forms. He has figured and minutely described the more interesting of these crystals, and the student who is technically inclined is respectfully referred to his memoirs here cited.† A full translation of his studies and the reproduction of his drawings should be included in some future edition of this report. I have thought it best to introduce in this paper a reproduction of at least ten of the many drawings made by the lamented Vom Rath that the student-reader may fully appreciate why so much interest has been attached to these crystals. See Plate 3.

*Mr. J. A. D. Stephenson and the late John T. Humphreys were the first to call attention to these modified quartzes, and their collections have been rich with them. Their pioneer work in collecting North Carolina minerals is deserving of a more lengthy notice.

†See *Zeitschr. für Krystallographie*, X, 156; *Ib.*, X, 475; XII, 453-459. *Sitzungsber. d. niederrh. Ges. für Natur- und Heilkunde*, 6, July, 1885, 45-55. *Verhandlungen des Naturh. Vereins d. preuss. Rheinl. u. Westf.*, 1884, 290-324. *American Jour. Science*, Vol. XXXII, Sep., 1886, p. 208; *Ib.*, June, 1887, p. 507.

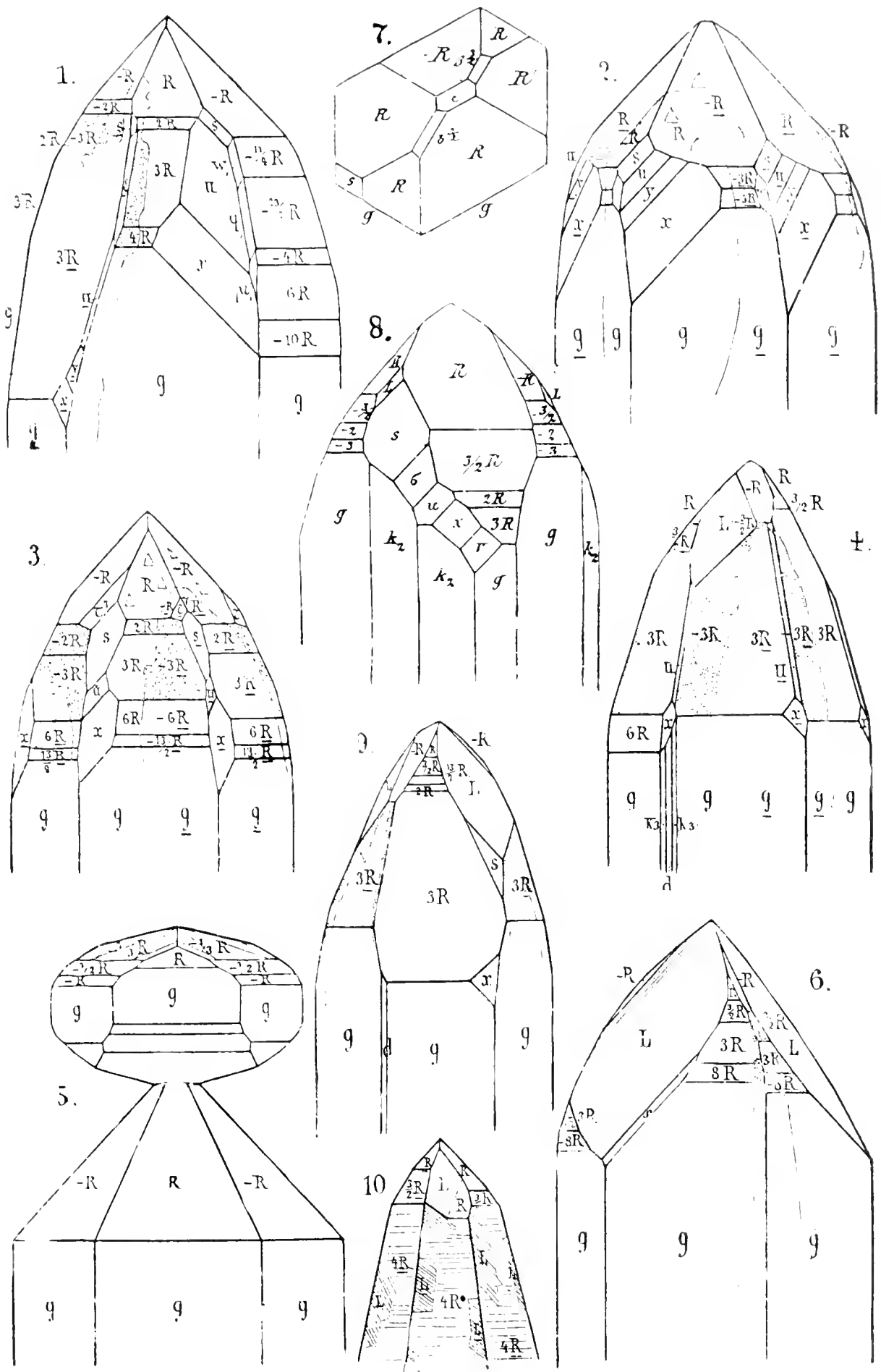

G. vom Rath del

PLATE 3—MODIFIED QUARTZ CRYSTALS, FROM ALEXANDER AND IREDELL COUNTIES: AFTER G. VOM RATH.



In Plate 3 the figures 1, 2, 3, 4, 5, 8 and 9 are of crystals discovered, by the writer, during the progress of the work at the emerald and hiddenite mine, and now constitute a part of the unique "suite" of North Carolina minerals owned by Mr. C. S. Bement, of Philadelphia.

Professor Vom Rath states that "nearly *all* the known forms of quartz seem to have been discovered in a small area of Alexander county, and much to his surprise he observed several planes (*twelve in all*) new to science." Certainly these quartz crystals far surpass, in their various points of scientific interest, all the discoveries in this species made elsewhere in this country within the past ten years.

Since 1879 the writer has been much interested in the so-called "basal-planes" on quartz crystals from North Carolina. My experience goes to prove that genuine basal planes are of very rare occurrence in this species. In the great majority of cases the planes observed have been produced by compression or juxtaposition. From among many crystals, appearing, when superficially examined, to possess this rare plane, I have selected only two which have a natural and normal development of the basal pinacoid. Upon being carefully measured with a *reflective* goniometer (by Alfred Des Cloizeaux, at Paris, May 8th, 1886) the angle $+R$ over $O = 128^\circ$, whereas the calculated angle is $128^\circ 13'$. Therefore the occurrence of this face is removed from all manner of doubt, as Des Cloizeaux has already stated. This plane seems often attempted to be formed, but the result is hummocky and uneven. A rough unpolished basal truncation is common on the Alexander and Burke county quartz crystals, but a smooth basal plane is a rarity.

Figure 7, Plate 3, exhibits a basal plane crystal (otherwise rarely modified) discovered by Mr. J. A. D. Stephenson in Iredell county, and is part of a remarkable "suite" collected and owned by him.

The quartz crystals from some of the localities in Western North Carolina have attained a wide celebrity from other reasons than their interesting outward form or their clearness; the inclu-

sions of fluids and gases have often been observed and of remarkable quantity. Crystals containing inclusions of fluids and gases are not uncommon, but crystals having such inclusions plainly visible to the naked eye are rarely found.

A brief description of a very remarkable "pocket" of these fluid-bearing crystals opened out some seven years ago at the now well-known gem locality in Sharpe's Township, Alexander county, would perhaps be of interest to record here.*

It was while prospecting for new veins bearing emeralds that this pocket was unexpectedly discovered. A narrow drift of quartz fragments, with small flakes of mica, was the only surface sign noticeable. At the head of this drift a shaft was sunk to a depth of nineteen feet, with the following interesting results:

The drift, within a foot of the surface, took shape as a solid vein of quartz, which rapidly widened until, at six feet depth, it had attained a width of fully three feet. Within the next two feet the pocket nature of the vein had become apparent by the presence of hard lumps of red clay, within which small crystals of quartz were found.

The vein for the next foot was almost entirely composed of this hard red clay. Then, to our great astonishment, one of the miners, striking his pick very forcibly, saw it disappear wholly from his sight. Naturally he was alarmed. We all thought for a time the safest place was at the top of the shaft. Feeling from past experiences at the locality that a cavity of not very unusual dimensions was about to be opened to our view, we descended and resumed the work.

Procuring a long stick, I probed this cavity, so as to ascertain its size, this being a necessary precaution to work it out properly and safely.

It was thus shown that the pocket was about three feet wide, seven feet long, and at that time about three feet deep, though I could push the stick quite deeply into the clay at the bottom.

*Trans. N. Y. Acad. Sci., March, 1882.

Exposing at full length the upper part of the cavity, it showed all along its sides and at the bottom stalactitic and stalagmitic forms of red mud.

The quartz, which at one time had completely lined the pocket, had, by process of disintegration, dropped into the open space below. It was in the mud and clay in the bottom of the pocket that all the crystals subsequently found were discovered. Only at the very bottom were the walls found *in situ*. This pocket differed in no respect from those commonly occurring in this region. They are all shrinkage fissures, situated in a contra direction to the strata, of very limited extent, and nearly perpendicular in position. The country rock is gneiss, with a dip nearly vertical. A thick layer of soil everywhere mantles and conceals it from view. Three days of careful work were spent in exhausting this pocket.

Over four hundred pounds of perfect quartz crystals were obtained from this one pocket, besides nine emeralds (already noted). Of good, bad and indifferent there was found in all nearly half a ton of crystals.

It was noticed that the crystals that had been directly attached to the walls were semi-transparent and without any great development of the prismatic faces, while implanted upon them as a secondary growth were crystals of great beauty and transparency, varying from citrine-yellow to dark chocolate-brown in color, and for the most part perfect in form. Two-thirds of them were perfectly terminated at both extremities and with considerable prismatic development. It was these latter that contained the fluid inclusions.

Large plates of rosetted mica were quite common, and on them were implanted small crystals of rutile and of quartz in rare perfection. When the smoky crystals were first found they were noticed to contain many cavities seemingly filled with a very clear and lustrous fluid. Though no bubbles of air (or gas) were observed to move in these cavities at that time, yet I knew these crystals to be the so-called "water crystals" of mineralogists.

I take pleasure in recording the remarkable size and quantity of the cavities enclosed in these crystals. The longest cavity noticed was nearly *two and one-half inches long* and one quarter of an inch wide. Cavities of one inch were not uncommon, while those of one quarter inch and less were, in truth, without number.

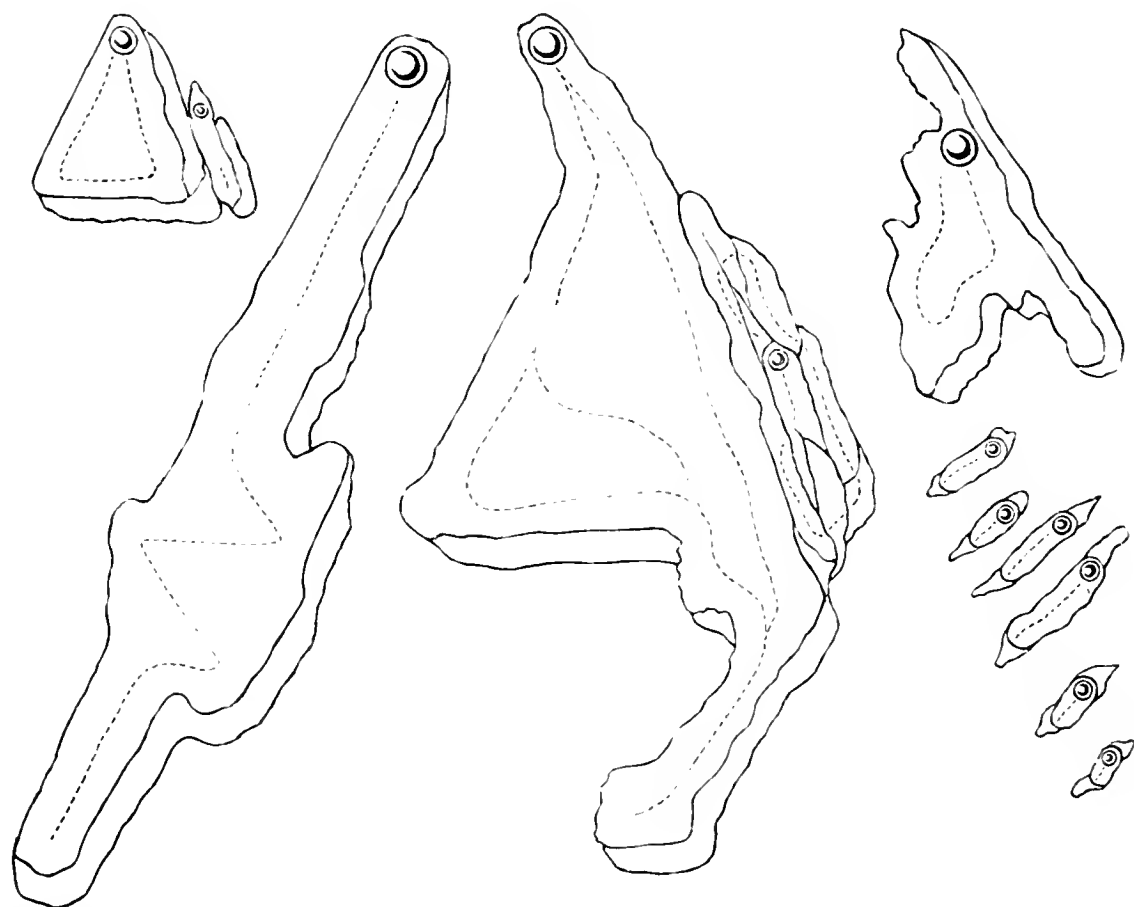

NATURAL SIZE OF SOME REMARKABLE FLUID INCLUSIONS OBSERVED IN QUARTZ CRYSTALS, FROM NORTH CAROLINA.

Many of the crystals seemed to be made up almost wholly of cavities, whose walls were barely thick enough to keep them separated. Many hundred, plainly visible to the unaided eye, could have been counted in a single crystal.

For some time after these crystals were removed from the pocket no bubbles were noticed in any of the cavities. Some peculiar condition of the crystal, or of the atmosphere, then existing, probably prevented their formation. Later the bubbles appeared in great numbers. A few of the crystals were, as water-bearing crystals, very remarkable in size. One weighed nearly twenty-five pounds, had both ends terminated, was of a dark-brown color, and as beautiful as any we have seen from

other localities. All the water-bearing crystals were large, none less than two inches in diameter, and many of over three pounds in weight. The cavities were arranged parallel to each other and to either a rhombohedral or a prismatic face.

An interesting phenomenon observed in these crystals did not occur until some time after their discovery. The best crystals of the "find" were carefully selected and placed where they were considered to be safe—safe at least from molestation. That the weather would interfere, or in any way affect them, did not enter my mind.

One evening in November I left these crystals nicely arranged at the mine, except a few of the smaller ones, which I carried to my log-cabin, thinking the while of what a treat I had in store for mineral collectors and for science.

During the night following the mercury unexpectedly descended below the freezing point. About midnight I was awakened by several sharp reports, like the explosion of gun caps. Over a dozen of these explosions occurred.

Upon the table, where the crystals had been placed the evening before, there remained the next morning only some few sharp fragments of quartz. Pieces of the crystals, large and small, were found even fifteen feet away. In fact, they were completely ruined. The cold had caused the water in the cavities to freeze and consequently to expand and then burst the crystals.

I hastened to the mine with the gravest fears for the safety of the finer crystals left there. Judge of my dismay to find not one of them, even the smallest, left intact.

Crystals that only a few hours before were rare examples of the workings of Nature's laws were now, by these same mysterious laws, left only as an evidence of her power to do and to undo her grandest achievements. Only crumbled masses of fragments remained to tell the story.

Those with few cavities had burst, scattering large fragments widely separated, while those containing minute cavities lay as a heap of small fragments frozen together *in a coherent mass*.

This last feature, while being a sad reminder in one respect, is of value to science, since it shows conclusively the abundance of the fluid included, and also, what is of more importance, that this cementing ice was formed either directly from the fluids *in the crystals* or by influences which they exerted. I do not believe this cementing ice was wholly formed by the freezing of the water contained in the cavities, but was gathered there by the attractive influence of the liquid carbon dioxide upon being so suddenly set free; that this liquid carbon dioxide did, by its natural affinity for moisture, create around it an atmosphere so cold that even the little dampness then existing in the air was congealed upon the crystal fragments.

As the room was a dark one I had all these masses and larger fragments carried out and placed in the sunlight, for no other reason than to examine them more carefully. I did not anticipate from this any further developments of scientific interest. Again, believe my astonishment, as soon as the rays of the sun touched them, to notice an ebullition commence at once, which, strangely, could be heard a few feet away. This ebullition was continued for over an hour, growing less as thawing progressed.

While holding a mass of frozen fragments my hand would become quite wet with the melting ice. I am not in error in stating that a cub. cm. of this fluid could have been easily saved had the proper means been at hand. It is much to be regretted that none was preserved.

I noticed some curious phenomena in a single fragment, which had by some means escaped destruction by freezing.

This specimen had several small cavities, arranged nearly parallel to each other. At temperatures below 70° a small bubble could be plainly seen to move in each cavity, as the position of the specimen was changed. It was further noticed that the cavities contained two liquids, in one of which the bubble was wholly confined in its movements. This was seen to be the central and more transparent fluid.

If this specimen was slightly heated (the mere heat of the hand was found sufficient) the bubbles would grow gradually less until they disappeared entirely, and the fluids would unite.

On cooling, a critical temperature would be reached, when all the cavities would be filled with numberless minute bubbles, which, rushing together, would in a few seconds form to its full size the bubble originally noticed. I found that this experiment could be repeated indefinitely, without any diminution of its interesting phenomena or risk of damage to the specimen.

To Alexander county, North Carolina, and to many of the surrounding counties, we can hereafter look to produce fluid-bearing quartz crystals second in interest to those of no other region in the world.

FALSE PSEUDOMORPHS OF QUARTZ.—In the older works on mineralogy mention is made of “pseudomorphs of quartz after barite,” “pseudomorphs of quartz after calcite,” and of “pseudomorphous quartz,” as occurring in Rutherford county, N. C. In all the mineral collections where the writer has seen specimens from this locality, they have been found labeled as above noted.

Opinions seem to have been divided between the identity of these forms with barite and calcite, though I have often heard them stated as representing the form of “an unknown species.”

The specimens are conspicuous for their ever varying and unsymmetrical forms, their inconstant angles, and for being almost invariably hollow, like geodes. The best specimens from Rutherford county, N. C., were found by Col. Twitty previous to 1870, and as early as 1850 the locality was well known. It had a local fame based upon the not unfrequent discovery of “water-bearing crystals” among the irregular quartz masses, which had a ready sale and were the cause of whatever development the locality ever received.

A second locality is situated in Iredell county, near Statesville, on the land of a Mr. Crawford. It is noted for the abundance of the material there occurring, the large size of the separable masses, the almost solid character of the forms and the non-

occurrence (as yet) of fluid-bearing masses. Otherwise the locality is similar to that of Rutherfordton.

From a careful study of the rock *in situ* and of many specimens from the localities, I am forced to conclude that these forms of quartz are *pseudomorphs of the interstices between crystals* of some mineral that crystallized in thin flat tabular forms.

Sections of these water-bearing forms present an interior of bright transparent crystals, or of mammillary chalcedony; while the structure of the walls is semi-radiated *from the exterior*. Careful examination of the surfaces show a series of triangular markings (angles 60°) on all sides. Now these markings are exactly what we would expect by the slow deposition of quartz on the basal pinacoid of a uniaxial crystal (rhombohedral), or of the deposition of quartz from solution in a vein filled up with meshed and netted crystals which being thin, presented only basal planes for contact surfaces. What the original mineral was is not shown by the specimens. The casts of crystal cavities in the larger masses show an unmistakable hexagonal prism with a large development of the basal pinacoid (these two planes identified by striations on the quartz), and this characteristic is persistent.

A careful test by Mr. J. B. Mackintosh of the fluid contents of a small four-sided crystal (?) proved it to be only neutral water, and the bubble to be only air (not carbonic acid gas as was expected).

It is to be hoped that at no distant day deep work at one of these localities will discover specimens of the thin hexagonal plates, which have left *only the interstices between them* in the form of a mould of quartz.

For the use of the figures of crystals, included in the foregoing pages, I extend to the editors of the *American Journal of Science* my sincere thanks.

INDEX.

Introductory note, page 45.

	PAGES.		PAGES.
Aeschynite	55	Muscovite	67-68
Allanite	54	Polyerose (?).....	55
Apatite	59-60	Pyrochlore (?)	54
Auerlite.....	64-65	Quartz, crystals.....	70-72
Beryl	50	Quartz, rock crystal	70
Cassiterite	65-67	Quartz, water-bearing.....	72-77
Columbite	55	Quartz, pseudomorphs.....	77-78
Cyrtolite	63	Rutherfordite	55
Diamond	46	Rutile	60-62
Dolomite	68	Samarskite	55
Emeralds.....	47-50	Spodumene ..	52-53
Euxenite	55	Thorite	63-64
Fergusonite.....	55	Tin	65-67
Gahnite	68	Tourmaline.....	62
Garnet ..	53	Tungsten	65
Hiddenite	50-52	Xanthitane	69-70
Malakon	62-63	Xenotime	55-56
Meteorites	69	Yttrio tantalite.....	55
Monazite	56-59	Zircon	53-54

NEMATODE ROOT-GALLS.

A PRELIMINARY REPORT ON THE LIFE HISTORY AND METAMORPHOSES OF A ROOT-GALL NEMATODE, *HETERODERA RADICICOLA* (GREEFF) MULL., AND THE INJURIES PRODUCED BY IT UPON THE ROOTS OF VARIOUS PLANTS.*

BY GEO. F. ATKINSON.

I.

INTRODUCTORY.

The purpose of the present paper is to put in the form of a preliminary report the result of some investigations made this autumn, in the neighborhood of the Experiment Station, upon the nature and cause of the abnormal growths found upon the roots of various plants. These deformities are popularly termed "root-knot." Soon after entering upon my new field of labor here my attention was called to the subject by the Director, Prof. J. S. Newman, who showed me tomato plants the roots of which were exceptionally "knotty."

The investigations were begun the first of October, 1889, and continued for about six weeks, when the subject-matter of this preliminary report was sent to the press.

At the time the work was undertaken I was unaware that a Bulletin was being published by the Division of Entomology, U. S. Agricultural Department, under the direction of Dr. C. V. Riley, embodying the results of investigations made by Dr. J. C. Neal, of the Florida Experiment Station. The first notice I had of this work was from *Insect Life*.†

That work‡ has since been distributed, and has reached me just about the time of going to press. Unfortunately there are many errors in the part dealing with the structure and life his-

Science Contributions, Ala. Polytechnic Inst., Vol. I, No. 1, Auburn, Ala., Dec., 1889.

†Vol. II, No. 3, Washington, 1889.

‡Bulletin No. 20, Division of Entomology, U. S. Dept. of Agr. The Root-knot Disease of the Peach, Orange and other Plants in Florida, Washington, 1889.

tory of the nematode, though some of the economic suggestions possess value. It is but just to Dr. Riley to say that he is not personally responsible for the errors contained in the Bulletin, since he states in an introductory paragraph (*loc. cit.*) that the nematodes "do not, in a zoölogical sense, strictly belong to the Division work. * * * The Bulletin makes no pretense to be a scientific treatise on the life history of these worms, but is in the main an effort to ascertain a suitable remedy. The general literature on the subject has not been at Dr. Neal's command, and my time is so fully occupied otherwise that I can do little or nothing at present in the way of identification of species or of comparing Dr. Neal's results with those of European investigators, which, as a matter of fact, are of little practical importance."

The conditions this autumn at Auburn have been quite favorable for determining a number of interesting facts relating to the development and transformations of this nematode, as well as the duration of a life cycle showing the number of successive generations in a year.

II.

EXTERNAL CHARACTERS OF THE DISEASE.

By a reference to Plates I, II and III the external characters of the disease can be seen. These plates represent respectively "knotted" specimens of the roots of the Irish potato, tomato and parsnip and salsify. Plates I and III are natural size; Plate II is reduced to two-thirds natural size. All are from average specimens. The abnormal growths on the tomato root appear as irregularly fusiform, knotty or nodulate enlargements, two to ten times the natural diameter of the roots. The surface of the gall is at first smooth, more or less undulate or papillate, but becomes later roughened, scurfy or cracked, and finally decay of the tissues sets in. The tap root and the earlier lateral roots were attacked early in the season, and when the photograph was taken they were partially decayed and falling to pieces. When the roots begin to die they send out new roots in the efforts of

the plant to recover from the effects of the disease. These roots, in turn, are attacked and deformed as represented in the figure. Other plants were found with the tap root still alive, very much enlarged and cracked, and the disease in an active state. The enlargements of the roots of the Irish potato are similar in form to those of the tomato, though on specimens I have examined they are not so large or numerous. The surface of affected tubers first presents minute elevations usually at the point on the surface corresponding to a lenticel. The minute elevation soon grows to be quite a large convex elevation and finally cracks. In the seed potato in the figure, Plate I, the cracks can be seen, while on the young potato represented in the upper left hand corner the projections are still quite smooth. These characters of the disease in the tubers will be referred to again.

There is great variation in the form of the galls even on the roots of a single species. Plate V, Figures 31 and 32, represent respectively the galls on the roots of the cotton plant and peach. The fibrous roots of the peach possess short ovoid, usually lateral galls; sometimes they are symmetrical. As the root becomes older and the disease spreads the external appearance is more as represented by the larger root in the figure, the surface irregularly enlarged, roughened and cracked.

This description of the external characters of the disease will serve to introduce the subject. A more detailed comparison of the variations in different plants will be given below.

III.

MICROSCOPIC CHARACTERS.

Upon examination the enlargements proved to be the galls produced by the presence of a nematode worm, *Heterodera radicicola*, Müll.* (*Anguillula radicicola*, Greeff,† *Anguillula arena-ria* N.‡ *ex-parte*). If we cut directly across one of these tomato

*Mittheilungen über unseren Kulturpflanzen schädliche, das Geschlecht *Heterodera* bildenden Würmer, Landwirthschaftliche Jahrbücher. Band XIII, Heft I, S. 1-42, Berlin, 1884.

†Sitzungsbericht. der Marburg Gesell. z. Beford. d. Naturwiss, 1872, S. 169.

‡Bulletin No. 20, U. S. Department of Agriculture, Division of Entomology, Washington, 1889.

root-galls, make a very thin shaving from the cut end and prepare it for examination with the microscope, the micro-characters of the disease will be revealed. Fig. 36, Plate VI, represents such a preparation magnified; *a* and *b* represent two female cysts; *a* is mature, *b* is in an earlier stage of development. If the female cyst is very old the cavity in the tissues of the root will be seen to be occupied by young thread-like worms—the larvæ, and eggs in different stages of development, floating in a semi-fluid, granular, gelatinous substance, the amorphous remains of the parent worm. See Fig. 37, Plate VI. If the knife in making the section should pass through a young female cyst, the cavity would seem to be occupied by granular protoplasm and numerous small fat globules, or, as in many instances is the case, the long tubes of the uterus and ovaries with young ova in different stages of development may be seen. If the knife should pass by the side of the animal without injuring it the cavity would then contain a perfect animal variable in form according to age or the character of the surrounding tissues of the root. See Fig. 29, *a* and *b*, Plate V; Figs. 36, *a* and *b*; 40, *a*, and 41, *a*, Plate VI.

In order to understand the real nature of the cysts, and the effect produced upon the growth and structure of the deformed root, it will be well to note the form and general characters of the mature female cyst, and then follow with a detailed account of the development, transformations and habits of the sexes, which forms one of the most wonderful and interesting subjects it has ever been my lot to investigate.

IV.

GENERAL CHARACTERS OF THE MATURE FEMALE CYST.

I have selected the mature female cyst as a preliminary study because of its comparatively large size as compared with the males or young, because it is so much more easily found than the males, and almost any one who has a low power microscope at hand can demonstrate with ease the general characteristics here given.

When the galls on the roots of some plant, which has tender tissues like the roots of the tomato, are badly cracked and in the incipient stages of decay, if one is broken there will usually be seen whitish or dull yellowish irregularly oval bodies, from one-fourth to one-half of a millimeter (one-hundredth to one-fiftieth of an inch) in diameter, that are easily differentiated with the unaided eye from the discolored and broken surrounding tissue. Usually the unaided eye can detect also the head end projecting as a minute point on one side, giving to the object the appearance of a minute "gourd," or "crooked-neck squash," or a minute inflated bladder. With the aid of a small hand-glass at least this peculiarity of form can be seen. These are the gravid female cysts.

Placing some of these cysts so that they can be seen under the microscope and magnifying them about one hundred times they will appear something like Figs. 34 and 35, Plate VI; or 27, Plate IV. The resemblance now to a small "gourd" is easily seen. The head is at the small end. In the mouth-hole can be seen a short slender cylindrical spear, broadened at the base, which ends in three short lobes. This spear is hollow, the anterior end lies in the mouth opening at the middle point of the head end of the animal. It is capable of extension at the will of the animal and is moved by pairs of muscles directly attached to it; Fig. 34, *a*, Plate VI. The spear of the male nearly agrees in form. This is represented more highly magnified in Plate IV, Fig. 21z, *c*, and Fig. 25, *a*. In this latter figure only two of the lobes at the base of the spear are represented. The mouth opening is cylindrical and behind broadens into the mouth-hole.

In the males the anterior end of the exsertile spear is supported by six lamellæ, the ends of which form the anterior end of the head and fit around the spear. A front view of the arrangement of the lamellæ presents a radial, stellate figure, which is shown in Fig. 24, Plate IV, drawn also from the male. The œsophagus begins at the base of the exsertile spear. The anterior part is a long, slender, tortuous channel which looks like

a dark line reaching to near the swelled portion of the cyst where is the middle part of the œsophagus. The middle part of the œsophagus is an ovoid or ellipsoidal transparent muscular bulb, which has a fibrillate structure, the fibrillæ radiating from the centre. Seen in side view this bulb looks very much like a small wheel. In Plate VI, Fig. 34, *b*, is the bulb or middle part of the œsophagus. The slender, tortuous channel, forming the anterior part, is represented connecting this with the base of the spear *a*. The posterior part of the œsophagus connects with the alimentary canal, neither of which are represented in the figure, as the mass of fat globules usually renders the body too opaque at this age.

Were it not for a slight movement of the apparatus just described, or a trifle "nodding" of the head, there would be nothing to suggest what we ordinarily consider a sign of life. Occasionally, even while the cyst is under microscopic examination, the exsertile spear is thrust slowly out at the mouth and then drawn back; at the same time the anterior part of the œsophagus, being connected with it, is also moved. Sometimes the apparatus slides far enough so that the tortuous anterior part of the œsophagus is straightened and the bulb is moved a little forward and backward. Sometimes there appears also a slight sidewise movement of the anterior part of the head, a sudden "jerky" motion. This sidewise movement of the head is probably from force of the habit of the worm in its larval stage when movement from place to place is accomplished by a constantly changing tortuous motion of the body. Müller* speaks of an expansion and contraction of the middle part of the œsophagus which he has observed. By this means nutriment from the plant is sucked in through the lumen of the spear into the œsophagus and thence into the alimentary canal. Now turning the eye upon the large part of the body the first thing to attract attention is the presence of two long cylindrical objects coiled within. Usually at this age of the cyst the development of

*Mittheilungen über unseren Kulturpflanzen schädliche, das Geschlecht *Heterodera* bildenden Würmer, 1884.

numerous fat globules on the interior of the body renders it so opaque that the terminations of these tubes and their connection with the body wall cannot be seen. Figs. 34 and 35, Plate VI, represent such opaque cysts. In some parts of the tube, however, can be seen polygonal cells, the faces where they meet making a zigzag line along the tube. Towards the posterior end of the cyst there can usually be seen oblong bodies lying within the tube or free in the body cavity. If these bodies are lying on their side they resemble a bean in shape. They are the *eggs*, and the long objects coiled within the body are the *genital tubes*.

By examining a number of mature female cysts from the galls of plants with soft tissues there will be found occasionally one which is not very opaque, as the fat globules are less numerous. Having found such a cyst we can see that the two tubes unite near the posterior part of the body and form a common passage, of a great diameter, but quite short, which extends to an opening, the *vulva*. Then by following with the eye the sinuous course of the tubes in the other direction the anterior ends will be found lying free within the body near the anterior portion. From the part where the tubes fork for nearly half their length is the *uterus*. The anterior free ends are the *ovaries*; the middle part functions as the *oviduct* and *receptaculum seminis*. Fig. 27, Plate IV, represents a cyst not very opaque; *d* is the vulva, *e* the uterus, and the free ends in the anterior portion the ovaries. The anal opening in the mature female cyst becomes displaced; it is represented in Fig. 27 at *f*. Fig. 28, Plate IV, represents the uterus and ovaries very highly magnified.

V.

DEVELOPMENT AND METAMORPHOSES.

(See Plate IV).

EGGS.—The young ova are developed in great numbers in the ovaries. Fig. 28 represents them when some are full grown and the genital tubes are crowded for nearly their entire length. They are very tender and plastic, and when free are spherical.

But packed and confined as they are in several rows inside the wall of the ovaries they are held in a polygonal form. Each one contains a large nucleus and a distinct nucleolus. When quite young they are nearly hyaline, and transparent. Near the anterior ends of the ovaries they are several layers deep across its diameter. As they grow in size the increased pressure forces the elongated mass of young ova slowly toward the uterus, since they cannot escape at the anterior ends of the ovaries. Then because the diameter of the posterior ends of the ovaries and the uterus is but little greater than the anterior ends of the ovaries the ova must be arranged in a decreasing number of rows, until a single ovum is equal in diameter to the inside diameter of the uterus. If we count the number of ova which stand in a superficial transverse row across a well developed ovary, near the anterior end there will be four or five; now looking along the ovary toward the uterus, we will count three, two and finally one. With the increase in size of the ovum there is an accompanying development of yolk globules. The first change is the appearance of very fine granules. Then yolk globules are developed, a few at first, but become very numerous as the growing ovum passes into the uterus, when it is quite opaque. The globules seem to be more numerous in a peripheral plane. The ova are held in polygonal form until one only occupies the diameter of the uterus, when they are at first rectangular in outline. From this form, as they grow in size, they simply elongate until their length is about two or three times their diameter. The ends of the egg are gradually rounded off, and it becomes slightly curved so that it is shaped very much like a bean. At first the ovum possesses a very delicate wall. The covering of the egg becomes stronger as it passes down the uterus. The fully developed egg possesses a double wall, a delicate inner membrane and an outer tough membrane.

Just the precise stage when the ovum is fertilized I have not determined, but I have found spermatozoa in the posterior part of the ovaries. The nucleus in the fully developed egg is quite distinct, though not so prominent as in the young ovum. It is

largely hidden by the mass of yolk globules. It is of a pale violet color. An examination of Fig. 28, Plate IV, will show many of these changes. A few of the eggs in one uterus have undergone various stages of segmentation preparatory to the development of the embryo. In dissecting living specimens very frequently the ovary or uterus becomes ruptured, in which case the ova in various stages of development escape from the great pressure exerted upon them by confinement, and not being entirely free from each other are held in beautiful grape-like clusters. Some of these are represented in Fig. 28.

The mature egg is from .08 mm. to .10 mm. long (three to four thousandths of an inch); exceptionally I have found them .12 mm. long. Thus far its development has been an increase in size, a profuse development of yolk globules, and a change in form. Its development from this point is the multiplication of cells by division, beginning with the single cell enclosed within the egg membrane. (See Fig. 1, Plate IV). Complete but somewhat irregular segmentation takes place. The nucleus first divides in two parts, forming two nuclei. Each nucleus moves a short distance towards its end of the egg. A transverse constriction now appears about the middle of the cell which progresses until the cell is divided into two cells (Fig. 2). The process is now repeated in each of these new cells resulting in four cells (Fig. 4). Sometimes one of these cells is completely divided before the other begins so that there may be three cells (Fig. 3). Occasionally the first line of fission is oblique, so that the two resulting cells are shaped as in Fig. 21. The egg now divides into six, eight, ten cells and so on. Usually the first division is such that one cell is larger than the other, but sometimes they seem to be about equal in size. Occasionally the first division results in two cells, one of which is only about one-third or one-fourth so large as the other. I have watched the cell division up to the stage represented in Fig. 7. Up to this point there is great variation in the disposition of cells at the different stages resulting from variations in the somewhat unequal segmentation. From this point up to that represented in Figs. 8 and 9 I have

not, owing to the limited time over which my observations have as yet extended, carefully determined the progress of development. Figs. 8 and 9 probably represent the stage where the larger endoderm (internal) cells are completely surrounded by the smaller ectoderm (external) cells, just prior to the invagination (sinking in) of the head end to form the mouth and œsophagus.

According to Strubell,* in *Heterodera Schachtii*, the first two unequal cells into which the egg divides represent primary cells of two different groups of cells which result from farther division. The larger primary cell divides more rapidly and forms small cells, which grow around the more slowly formed larger cells which result from the division of the other smaller primary cell. The growing over proceeds first down the convex side of the egg and the ectoderm cells fold over the opposite end of the embryo, the mass of endoderm cells. Thus the "prostom" (the open space between the converging edges of the enveloping ectoderm cells) is on the concave side of the egg, and because the ectoderm cells on the concave side of the head end have grown but little it (the prostom) occupies the entire concave (ventral) side of the young embryo. At this stage if we turn the egg so that we are looking directly at the concave side the ectoderm cells will be in a boat-shaped mass, and in this boat-shaped mass of ectoderm cells will be the larger endoderm cells. The "prostom" (open part of the boat-shaped mass of ectoderm cells) now begins to close by the growth and increase of the cells at the margin. This closure takes place more rapidly at the posterior end and advances toward the head end, so that after awhile there is only a small opening through the ectoderm cells near the head end of the concave side. This is finally closed so that the endoderm cells are completely enveloped by the smaller ectoderm cells.

This is probably the stage which I have figured in Figs. 8 and 9, Plate IV. The larger, endoderm, cells can be seen in the centre; the smaller, ectoderm, cells on the outside. Invagination of the ectoderm cells now takes place at the head end, that is, the cells sink inward as if pushed in by some outside force. This is represented in Figs. 9x and 10. By this process the mouth and œsophagus are developed. I have only studied the external changes in the embryonic development. From this point up to the fully developed larva the changes are represented in Figs. 11 to 15. Beginning with Figs. 10 and 11 the head end appears hyaline and finely granular, and is larger in diameter than the rest of the young embryo, which at this stage is of

*Untersuchungen über den Bau und die Entwicklung des Rubennematoden, *Heterodera Schachtii* Schmidt. Bibliotheca zoologica, Heft 2, 1888.

equal length and diameter with the inside of the egg membrane. It next begins to elongate and become more slender. This forces it to double up inside the egg membrane. It does so by turning its tail end by degrees around to its ventral side (Figs. 11, 12). In some cases the tail end for a time does not move. This causes the embryo to double up midway, and sometimes to be coiled in a spiral manner for awhile. It now continues to elongate until it is coiled twice (Fig. 13), then three times (Fig. 14), and finally four times (Fig. 15), within the egg membrane.

I have watched the egg and embryo, under the microscope, pass through all these changes. Sometimes the embryo would double its length in eight or ten hours. When it has reached this stage it remains a day or so still within the egg membrane while the cuticle, the tough transparent body wall, is being perfected, and the slender pointed end of the tail is formed. Now by its writhing and twisting it ruptures the tough egg membrane and is set at liberty. At this stage the larva passes through its first moult, either just as it is coming from the egg membrane or very soon afterward. Fig. 16, Plate IV, represents the larva in the act of coming from the egg membrane. It is moulting at the same time. The thin larval skin can be seen slipping off its head and tail.

As the female remains in a cystic state and the cyst is surrounded by the tissues of the plant the eggs when crowded in the uterus rupture it and finally the numbers of them completely fill the body cavity of the cyst. In a few cases, after freeing a cyst, I have observed eggs pass out at the vulva.

Segmentation of the egg begins before it leaves the uterus, and we find, in the body cavity of live female cysts, eggs in all stages of development, and free larvæ, so that the female may be said to be oviviparous.

LARVAL STAGE.—The larval stage begins with the hatching from the egg. The moult which takes place at the same time is the first moult of the larva. The young thread-like worm is from .3 mm. to .4 mm. (twelve to sixteen thousandths of an inch) long; it tapers gently to the blunt head end, and gradually into

a slender pointed tail (Fig. 17). In this form it resembles what are called "vinegar eels." In the head end we notice the exsertile spear, with its tri-lobed base, the long, slender, tortuous channel of the anterior part of the œsophagus, and the ellipsoidal muscular bulb, the middle part. The lumen of the alimentary canal can also be seen, and it opens at the beginning of the hyaline space near the tail end. (See Fig. 17, Plate IV). The embryo, and for a time the young larva, possesses a cellular matrix inside the body wall, except at the head and tail ends. This soon develops numerous fat globules which are clustered around the alimentary canal.

The young worms, when ushered into life, find themselves imprisoned by walls of plant tissue which formed at once the prison-house and tomb of their parent. (See Fig. 37, Plate VI). How to escape these bars is their first concern. Perchance fortune may favor them if the cyst is near the surface of the gall so that a crack or partial decay of the tissues may liberate them. When not thus favored there are sometimes two courses open to them, more often only one. If the cyst opens into any of the large channels of the vascular tissue of the root, which is frequently the case, the larvæ may make their exit through these to other parts of the same root. In a majority of instances the worm must face the only alternative of starvation, and actually *batter* a hole in the wall through which it may escape. Taking position, with the head end against a cell wall, it thrusts forward the exsertile spear, which strikes the cellulose wall forcibly, when it is drawn back and thrust out again. This process is repeated until a hole is made through the wall large enough to admit the body of the worm, into which it passes, and by successively battering down the cell walls of the surrounding tissues it makes its way to freedom on the outside of the gall or to a fresh portion of the same root.

Having escaped from its confinement, by one of these three courses, it immediately selects another part of the root or a fresh young rootlet for attack and places itself in position for the siege. Bringing into play its exsertile ram, it forcibly gains

entrancé to the healthy tissues of the root. The plant, not able to expel the invader, bends its energies in a vain endeavor to repair the injury to the roots. Increased development of cells takes place, and normal ones are turned from their proper position and function and also very much enlarged. The result is the formation of a gall, an increase of tissue in the root, which supplies food and protection for hundreds of the worms, all which lessens the energies of the plant normally directed to the production of leaf and fruit.

The larvæ wander for a time through the tissues and finally come to rest. Plate VI, Fig. 39, represents a larva as it is wandering through the tissues of a potato tuber. It now moults the second time and passes into a truly parasitic condition.

CYSTIC STATE.—The larvæ locate at various depths in the tissues. The body now begins to enlarge, except at the two ends. Speaking vulgarly, it would be said to “swell up.” Almost before any increase in size of this part of the body is noticed the worm becomes rigid and could not move if it would. Its body may be turned or twisted in very curious shapes when this rigidity or fixedness comes upon it. (See Plate IV, Fig. 17*v*). The enlargement begins close behind the muscular bulb of the œsophagus, and for a little time this part of the body is larger than the posterior part. Very soon the enlarging takes place all along the body to the hyaline space near the tail end, and this portion of the cyst becomes generally of a greater diameter than the anterior part. The cyst is at first rudely spindle-shaped, then clavate (or club-shaped), with a very small sharply pointed process, the tail, at the larger end. Fig. 18 represents the spindle form, 19 the clavate form. Up to this point it is difficult to distinguish the sexes, but from this point they sharply diverge. The female cyst continues to enlarge, while the male undergoes a wonderful transformation and returns to the thread-like or *anguillula* form.

TRANSFORMATION OF THE MALE.—The body of the male at this point is the same size as the interior of the cyst, very stout in proportion to its length. The first sign of a transformation

is the slipping of the head from the wall of the head end of the cyst. At the same time the thick body of the male begins to elongate and double up inside the cyst, while the tail end, stout and blunt, begins to curve around. This makes the third moult. (See Fig. 21, Plate IV). While the male is elongating and coiling up in the cyst it begins to moult again, making four moults. The very thin skin can be seen partly slipped off the worm while yet within the cyst (Fig. 21). The male continues to elongate and become more slender until it is coiled three, four, or more times, dependent on the length of the cyst, within the walls of the cyst, which still retain perfectly the shape of the cyst when the transformation began. Even the exsertile spear moults, for its "mould" is left in the head end of the cyst, while the skin of the larval tail still projects as a slender process. The male coiled within this perfect wall of the cyst is a very beautiful object. Figs. 21*a* and 22 represent these. During this transformation the sexual organs of the male have become matured. It now breaks through the wall of the cyst and the surrounding tissue and travels blindly through the maze of cells until it comes to its mate, when it pairs and then dies. Fig. 23 represents a male coming from its cyst. Fig. 21*z* a male of *Heterodera radiceicola* removed from a cyst.

STRUCTURE OF THE MALE.—It may be well now to note some things about the structure of the male which were not described in the section upon the "General Characters of the Female Cyst." It is from 1 mm. to 1.5 mm. (one twenty-fifth to one seventeenth of an inch) long and about .043 mm. (seventeen one-thousandths of an inch) broad near the middle. Its body a little less in diameter at the posterior end; the anterior half of the body gradually tapers to the head end, which is about half the diameter of the middle. The body wall is beautifully marked by prominent transverse striae broader and much more distinct than in the larval stage. The head, exsertile spear and oesophagus have been described. The excretory canal on the ventral side opens a little posteriorly to the muscular bulb. The caudal end (tail end) is slightly curved, and very near the end are the two curved *spicules*.

The *generative organ* is paired, the long slender *testes* lying on either side of the alimentary canal reach by their free anterior ends to about the middle of the body. See Fig. 21z, Plate IV. Some little distance from the caudal end of the body they unite into a *common canal*, which itself near the spicules unites with the alimentary canal, forming the cloaca. The *spermatozoa* are spherical. The cellular structure of the testes resembles that of the ovaries to some extent. The cells are polyhedral, and in side view the lines separating them are zigzag. See Fig. 21z, Plate IV. In live males the spherical spermatozoa are easily seen at and near the common passage, but they are developed in the anterior ends of the testes. By boiling infested potatoes to soften them so that I could remove the cysts and mature males without cutting or mashing them, I found that it toughened the tissues of the animals, and made the cellular structure very distinct. I possess several microscopic mounts of the males and one with the male in the act of coming from its cyst.

DEVELOPMENT OF THE FEMALE.—About the time the cysts have reached the stage when the male begins its transformations it is quite easy to distinguish the female cyst. The alimentary canal is very large and up to this time in both sexes has occupied nearly the entire cavity of the cyst. Now it begins to deteriorate and the ovaries begin to come to maturity while the cyst continues to enlarge. While the female cyst still possesses the slender tail process*, the irregular, slender hyaline cornua of the generative organs may be seen one on either side of the large intestine, which is covered with fat globules and is quite opaque, or more so than the genital tubes. See Figs. 19 and 19z, Plate IV. The vulva, the opening for the uterus, is at the point in these figures where the tail process joins the cyst. The cyst continues to enlarge, or “swell,” until the tail part is cast and thrust aside. The vulva is now at the posterior end, and in some cases the body is so much enlarged that a depression is formed at this point (see Fig. 27, Plate IV). The ovaries continue to elongate; and fertilization takes place long before the cyst has ceased enlarg-

*Probably the remains of the second moult.

ing. The ova begin to develop while the cyst is comparatively small. Before the ovaries are fully developed they are capable of a slight independent motion. Frequently in examining those dissected from living cysts I have noticed a marked twisting and tortuous motion, probably due to a contraction of muscles in the walls. The body wall of the female is marked by irregular transverse striæ, but not so prominent as in the male.

LENGTH OF LIFE CYCLE.—This completes a life cycle of our *Heterodera radicicola*. It passes through all these changes, from the development of eggs, successively through the larval and cystic state until eggs are again developed, in about one month. This I was able to determine by watching the development of the worms in the roots of "volunteer" potatoes which sprouted about the first of October and were infected from the soil and the "seed" potatoes. Thus in favorable seasons there would be at this latitude seven or eight successive generations in a year. Farther South, where the season is longer, probably the number of generations is increased. When we consider the number of eggs one female is capable of producing, from one hundred to two hundred or more, it will be seen that the worms multiply with startling rapidity. The periods of transformation of different individuals do not altogether coincide, so that at almost any season we may find worms in every stage of development.

BRIEF RECAPITULATION OF THE LIFE HISTORY.—*Egg*—The oblong, bean-shaped egg, .08 mm. to .10 mm. long, developed in the anterior part of the ovaries, after fertilization, enclosed in a double-walled membrane, undergoes partial or complete segmentation while yet within the uterus. From the beginning of segmentation to the fully developed larva five to seven days are required. The thread-like larva is coiled three or four times within the egg membrane. *Larva*—At the time of hatching or soon thereafter it moults for the first time. It is "thread-like," blunt at the head end and narrowly pointed at the tail end, .3 mm. to .4 mm. long. In the head end can be easily noted the exsertile spear and the long, tortuous channel of the anterior part of the œsophagus extending to a prominent ovoid or ellipsoid

muscular bulb, the middle part of the œsophagus. From this point the lumen of the alimentary canal can be seen extending down through the middle of the body, in which is a matrix that develops many fat globules; the anus is situated at the beginning of the hyaline portion of the tail end. The larva now leaves the cyst cavity and enters a fresh root or different place in the same root. It wanders for a time when it comes to rest, moults a second time and then being fixed enlarges, or "swells up," into a cyst with a flask-like body, the head projecting at one end and the slender pointed tail at the other. At this time prominent sexual transformations take place. *Male*—The male moults again (third time), leaving the outer wall of the cyst intact, while the body of the male elongates, narrows and becomes coiled three or four times within the cyst. While this change is going on the male moults again (fourth time). It is now from 1 mm. to 1.5 mm. long, anguillula-like, blunt at each end, slightly curved at the caudal end, where are two curved spicules. In the middle line of the body runs the alimentary canal, in the posterior half of the body are the paired testes, which are united into a common duct near the caudal end, and at the cloaca this unites with the intestine. On each side within the body is a muscular cord extending the entire length of the worm. *Female*—The female does not moult again, but continues to enlarge enormously until it is gourd-shaped, and the paired generative organs, opening by a common passage at the vulva in the posterior part of the body, form long tubes which lie coiled in the body of the cyst, free at their anterior end. As the embryos are developing the body of the cyst breaks up into an amorphous gelatinous mass in which the young larvæ and eggs are found floating within the cyst cavity. Length of life cycle, one month.

METAMORPHISM OF HETERODERA.—One of the features of the greatest morphological interest in *Heterodera* is its singular metamorphic character. This metamorphism finds its completest analogy in some forms of the *Coccidæ** where the larvæ, after

*Strubell, Ad. Untersuchungen über den Bau und die Entwicklung des Rubennematoden, *Heterodera Schachtii* Schmidt. (Bibliotheca Zoologica. Originalabhandlungen

pursuing for a time a wandering life undergo a metamorphosis† accompanied by what appears to be a retrogression, so that the creatures lack the power of locomotion. At the third moult of the male it is transformed again into a more highly organized being, possessing wings and capable of seeking its mate. On the other hand, the female remains fixed and incapable of locomotion, and after impregnation by the male becomes enormously distended with eggs. It must be borne in mind, however, that this analogy is only superficial. *Heterodera* does not lose its power of locomotion through any retrogression of form like the loss of organs which occurs in the *Coccidae*, though, according to Strubell, some parts of the head undergo retrogression. It is because of the rigidity and distension of the body of both male and female so that it cannot perform the undulatory movements of the body by which locomotion in the larval state and in the adult male is accomplished. The fact that the cyst is surrounded by the tissues of the plant does not interfere with its independent locomotion.

The cyst‡ differs morphologically from that of *Nematodes* like *Trichina*, where the larva becomes encysted in the muscles of its host and does not undergo any remarkable change of form in the formation of the cyst, the walls of which are formed from extraneous and excreted matter. It somewhat resembles in its origin and earlier stages the earlier stages of certain of the *Cestodes* like *Tenia*,§ where the embryo after it is located in the tissues of its host develops by distension into a vesicular body. Here, however, the resemblance ceases, and the walls of the *Tenia* cyst by invagination or evagination produce the head of the worm, or

aus dem Gesamtgebiete der Zoologie, hrsg., von R. Leuckart u. C. Chun, Heft 2) 49-50 pg. 2 Taf. Cassel (Th. Fischer) 1888.

Centralblatt für Bakteriologie und Parasitenkunde. Bd. VI, No. 15, pp. 423-429, Jena, 1889.

Müller, Mittheilungen über unseren Kulturpflanzen schädliche, das Geschlecht *Heterodera* bildenden Würmer. Landwirtschaftliche Jahrbücher, Bd. XIII, Heft 1, 1884.

Sorauer, Pflanzenkrankheiten, Zweite Auflage, Erster Band, pp. 852-854, 1886.

Strubell, Ad. Ueber den Bau und die Entwicklung von *Heterodera Schachtii* Schmidt. Zool. Anzeiger, No. 212, 17, Januar, 1887., pp. 42-46, und No. 213, 31, Januar, 1887, pp. 62-66.

Centralblatt für Bakteriologie und Parasitenkunde. Band I, pp. 603-604, Jena, 1887.

†Comstock—An Introduction to Entomology, Ithaca, N. Y., 1888.

Ann. Rept. U. S. Dept. Agr., 1889.

‡My use of the term cyst is mainly for convenience.

§Text-book of Zoology, Claus and Sedgwick.

scolex, or in some cases the brood capsules, from which several heads are produced. In *Heterodera* the vesicular distension of the larva begins after a period of wandering through the tissues of its host. Instead of invagination the wall of the male vesicle is cast, and retains the cystic form while the worm elongates and coils within it. In its "pupa" condition the male more nearly resembles *Echinorhynchus*, where the embryo after a wandering state comes to rest in the tissue of its host, develops a small elongated larva, which is surrounded by its firm external skin as a cyst.* The female vesicle continues to distend until in age its body is filled with eggs and young larvæ. This condition of the female has been termed by some† a "brood capsule," but it of course bears no morphological semblance to the brood capsules of certain *Cestoda*. I regret that I find it necessary here to call attention to some serious errors on the part of some of our American investigators.

One of these errors is that into which Dr. Neal‡ has fallen in his treatment of the life history of this parasite. He speaks of the eggs as "cysts." This may have been due to the fact that he regarded the numerous yolk globules in the ovaries as cells, for he speaks of the cysts (*loc. cit.*) which were at first without any "epidermis," being formed by "an agglomeration of cells." What he represents in Plates IX and X, as segmentation of the "cysts," is only a representation of the first stages of segmentation of the egg.

It appears that Professor Scribner made a similar mistake in speaking of the "cysts" and "eggs" of the nematode which causes the new disease of the Irish§ potato described by him. What he speaks of as the "cysts" are the egg membranes still containing the young larvæ. What he figures as the mature worm is a young one, and the round granules which he speaks

*Text-book of Zoology, Claus and Sedgwick, Vol. I, p. 362.

†Strubell, Ad. Untersuchungen über den Bau und die Entwicklung des Rubennematoden, *Heterodera Schachtii* Schmidt. Bibliotheca Zoologica, Heft 2, 1888.

Centralblatt für Bakteriologie und Parasitenkunde. Band VI, No. 15, pp. 423-429, Jena, 1889.

‡Bulletin 20, U. S. Dept. of Agr., Division of Entomology, Washington, 1889.

§Bulletin of the Agr. Exp. Station, Tenn, Vol. II, No. 2, 1889.

of as eggs are probably fat globules. I have found potatoes here affected with a similar disease while also attacked by *Heterodera radicicola*. I have found the worms representing all stages of development. It appears that they do not form cysts in the proper sense of the word. Fig. 46, Plate VI, represents a mature female of this worm. At *a* is a fully developed egg yet within the uterus, while *b* represents young ova not fully developed. In the body of the worm, as well as in the eggs, can be seen the round globules. Figs. 42 and 43 represent eggs; 43, an egg having undergone fission. Other eggs were observed in different stages of development up to the fully formed larva represented still within the egg membrane at Fig. 44. Fig. 45 represents young worms of this species.

Fig. 47 represents a different species occasionally found accompanying these worms, but whether they are parasitic or not I have not yet had the time to determine.

Several of the worms which Dr. Neal has figured do not belong to *Heterodera*. Especially in decaying tissues one is apt to find species which are not parasitic. However, wherever they were found it is very clear that some belong to other genera than the worm in question. For example, his Fig. 2, Plate XIII (*loc. cit.*), is a mature female of another genus. An egg is represented in the uterus near the letter B, and the numerous yolk globules he speaks of as a peculiar arrangement of cells.

COMPARISON WITH *HETERODERA SCHACHTII*, SCHMIDT.—

There are many points of very close resemblance between *Heterodera radicicola* and *Heterodera Schachtii*. Both of these are European species, and each is known to attack widely different plants, so that the selection of a particular plant or family of plants as a specific peculiarity is not their habit. Notwithstanding the points of resemblance there are a number of differentiating characters heretofore used, the value of which can only be determined after careful study and experimentation, and even now some of these are known to be variants possessed by both species. The female of *Heterodera Schachtii* is said to be ectoparasitic, the posterior part of its body being nearly or quite

exposed. This results from the larva locating very near the surface so that its distended vesicular body breaks the surface and becomes exposed. This does not seem to be a character of very much value since many of the female cysts of *Heterodera radicicola* are exposed.

The chief morphological differentiating characters which have been employed are as follows: The posterior part of the body of the female is rounded in *Heterodera radicicola*. In *Heterodera Schachtii** the posterior part of the body of the female projects into a short, stout process in which is the vulva. According to Strubell (*loc. cit.*) the exsertile spear is somewhat differently constructed in the females of the two species. I have only found one female which possessed the stout process at the posterior part of the body. One of the most prominent differentiating characters used in the case of the males is the presence of the slender tail process in the cyst in *Heterodera radicicola* and its absence in *Heterodera Schachtii*. Dr. E. L. Mark, of the Museum of Comparative Zoology, Cambridge, Massachusetts, who, before my copy of Strubell arrived, kindly compared for me some copies of my drawings with those of *Heterodera Schachtii* by Strubell, and aided me in the interpretation of some of the phases of egg segmentation, has made the suggestion that possibly the slender tail process in *Heterodera radicicola* may be the result of the retention of the first larval skin which is lost in *Heterodera Schachtii*. After this suggestion it has occurred to me that the first larval skin (at second moult) in those I have observed is cast at the time the larva comes to rest preparatory to passing into the cystic stage. In such moults I have only observed the skin as it was loosened from the anterior part of the body. Strubell says, in the case of *Heterodera Schachtii* (*loc. cit.*, p. 44), that frequently the old larval skin remains attached to the hinder part of the larval envelope ("cyst") so that it has the appearance of being pointed.

*Strubell, Untersuchungen über den Bau und die Entwicklung des Rubennematoden, *Heterodera Schachtii*, Schmidt. Bibliotheca Zoologica, Heft II, 1888.

Müller, C. Mittheilungen über unseren Kulturpflanzen schädliche, das Geschlecht *Heterodera* bildenden Wurmer. Landwirthschaftliche Jahrbücher. Bd. XIII, Heft I, 1884.

He is also inclined to think that the grounds for considering the two species distinct are questionable. In a foot-note, p. 11, he states that he is strengthened in his belief by the recent researches of Ritzema Bos in Wageningen (Biolog. Centralblatt, Bd. VII), who finds that such species as *Tylenchus devastatrix*, *allii*, *Havensteinii* et *Askenasyi* must be united into a single species.

That these two species of *Heterodera* are identical has been suggested by others.*

During my study of *Heterodera radicum* I have been strongly inclined to consider it identical with *Heterodera Schachtii* since many of the variations of the two species tend to reconcile the above-mentioned differences. However, since my copy of Strubell's work has arrived and I have had an opportunity to compare it carefully with my own researches I find there exists a difference in the structure of the males of very great morphological importance. Strubell states that the genital apparatus of the male is an unpaired tube,† the single tube occupies the ventral side of the body cavity for half its length, the posterior end unites with a short efferent duct which itself unites with the intestine to form the cloaca. As I have stated in a former paragraph the genital apparatus in the males I have studied is paired, the two tubes unite near the posterior end of the body to form the efferent duct. It is difficult to see how Strubell could have overlooked a second tube, if it existed, since his work was done under the aegis of Leuckart. This character possessed by comparatively a few nematodes seems of too great importance for specific variation. To re-assure myself I referred again to my microscopic mounts of the male. Müller's (*loc. cit.*) imperfect study of the male leaves us no clue as to the structure of the genital apparatus in *Heterodera radicum*. Until the European species is studied it will be impossible to say whether mine is a distinct species.

*Sorauer, Pflanzenkrankheiten. Zweite Auflage, Erster Band. Foot-note, pp. 854, 855.

†"Bei unseren *Heterodera* präsentiert sich derselbe als ein einfacher Schlauch," etc., p. 22. See also his Fig. 1, Taf. 1.

My Figs. 21, 23, 25 and 26, Plate IV, represent a male which differed from *Heterodera radicicola* mainly in the presence of a short curved caudal process represented at *a*, Fig. 26. At first I thought this might possibly be a different species from *Heterodera radicicola*, but as I only found one specimen I have concluded it may possibly be an accidental variation.

All of the males which I have studied were found in potatoes. My impressions are that the species in all the different galls found here are identical. More than this at the present time could not be said. As this report is only preliminary, and it has been impossible for me during the very short period of my observations to find and carefully study the males, where we must probably look for the most satisfactory specific characters, in the different galls, I hope to continue these investigations during the coming year. This will also afford me an opportunity to study more fully some structural features necessarily passed over in the present work.

DISTRIBUTION OF HETERODERA.—The genus *Heterodera* is world-wide in its distribution. It has been long known in central Europe, where *Heterodera Schachtii* was discovered by Schacht* in 1859 and named by Schmidt† in 1871. *Heterodera radicicola* was first recorded in 1872 and named as *Anguillula radicicola* by Greef,‡ and transferred to this genus by Müller§ in 1884. It has been found in Java in the roots of sugar-cane by Treub,|| who named the species *Heterodera Javanica*, the characters being based on some differences in size of the females from *Heterodera radicicola*. Beijerinck¶ doubts if it is distinct from *Heterodera radicicola*.

*Ueber einige Feinde der Rubenfelder. Zeitschrift, d. Ver. d. Rubenzuckerindustrie. Bd. IX, S. 175—179, 1859.

†Ueber den Ruben-Nematoden (*Heterodera Schachtii* A. S.) Zeitschr. d. Ver. f. d. Rubenzuckerindustrie im Zollverein. Bd. XXI, S. 1-19, 1871. (Both cited by Muller, Mittheilungen über unseren Kulturpflanzen schädliche Würmer).

‡Sitzungsbericht. d. Marburger Gesellschaft z. Beford. d. Naturwiss. S. 169, 1872. (Cited by Muller, Mittheilungen, etc.).

§Mittheilungen über unseren Kulturpflanzen schädliche, das Geschlecht *Heterodera* bildenden Würmer. Landwirthschaftliche Jahrbücher, Bd. XIII, Heft 1, 1884.

||Quelques mots sur les effets du parasitisme de l'*Heterodera Javanica* dans les racines de la canne à sucre. Ann. d. Jardin bot. de Buitenzorg, Vol. VI, Part I, pp. 93-96, Leide, 1886. Abstract in Bot. Centralblatt, Bd. XXVIII, p. 269, 1886.

¶The Gardenir-root disease. Gard's Chron. ser. III, Vol. I, pp. 488, 489, 1887. Abstract in Bot. Centralblatt, Bd. XXXV, p. 92, 1888.

It was known in Brazil in the year 1878* in the roots of the coffee tree, and has since been studied and published under the generic name *Meloidogyne* by Golbi.† Leuckart is of the opinion that this is a species of *Heterodera* (see foot-note in Centralblatt für Bakteriologie und Parasitenkunde, Bd. V, p. 840, 1889). It is also known in Scotland, according to W. G. Smith.‡

Dr. Neal§ states that it cannot survive the cold of severe winters in America north of about the January isotherm of 50° as shown in the No. 2 Isothermal Lines of the U. S. Signal Service, 1881. I do not know that any experiments have been conducted to demonstrate this. If it can survive the winters in Scotland it can endure the winters of all our Gulf and South Atlantic States. The January isotherm of 50° strikes the Atlantic coast just below Savannah, includes the south-eastern corner of Georgia, the very southern limits of Alabama, and a corner of Louisiana. The isotherm of the same month and year which passes near this place is 45°. It starts above Charleston, cuts Georgia through the centre and passes a little south of Montgomery. The isotherm of 40° starts near the boundary corner of Virginia and North Carolina, passes north of Atlanta, and includes the major part of Alabama, Mississippi, Louisiana and Texas. The average temperature of Edinburgh, Scotland, during the month of January is about 39°, so that we might fully expect the root-gall nematode, if once introduced, to thrive as far north as the January isotherm of 35°, or even farther. This isothermal line starts in at the coast north of Norfolk and runs through middle Tennessee. Indeed, I am inclined to think if a favorable oppor-

*Sur une maladie du Cafeier Observee au Bresil. Compt. rend. hebd. acad. sc. Paris, 1878, T, LXXXVII, No. 24, S. 941-943. Abstract in Bot. Jahresbericht (rust), p. 173, 1878.

†Relatorio sobre a molestia do cafeeiro do Rio de Janeiro. Bd. VIII, Arquivos do Museo nacional do Rio de Janeiro.

‡Biologische Miscellen aus Brasilien, VII. Der Kaffeemotode Brasiliens, *Meloidogyne exigua* G. Zoolog. Jahrbucher, abth. f. System., Geogr. u. Biol. d. Thiere, Bd. IV, Hft. I, pp. 262-267, Jena, 1889.

§Abstract in Centralblatt für Bakteriologie und Parasitenkunde, Bd. V, pp. 839-840, 1889.

‡Disease of Oats—*Heterodera radicola*, Muller, Gardeners' Chronicle, New Ser., Vol. XXI, p. 172, 1886. Abstract in Bot. Centralblatt, Bd. XXXI, p. 247, 1878.

§The Root-knot Disease of the Peach, Orange, and other Plants in Florida, due to the work of *Anguillula*, Bulletin No. 20, Division of Entomology, U. S. Dept. Agr., Washington, 1889.

tunity should occur for its introduction into our States even so far north as New York and Ohio that from its habit it might easily pass the winter in sufficient numbers to become a terrible pest. On long rooted plants like the parsnip I have found them in great numbers fifteen inches below the surface of the ground. On tomato roots, which were placed in the soil very deep to get them if possible out of the way of the attacks of the worms, I have found them so low as eighteen inches below the surface. This depth would protect them from the frost in the very severe winters of some of our Northern States.

There is to some extent a natural barrier to the spread of the root-gall nematode from the Southern to the Northern States, which is explained by the fact that very few, if any, perennials grown in the South are transported North for cultivation. However, the subject is of sufficient importance to the Northern States to justify an inquiry into the possibility of its being successfully carried through the winter under the conditions I have stated.

VI.

STRUCTURAL CHARACTERISTICS OF THE DISEASED ROOTS.

NOMENCLATURE.—The abnormal growths on the roots caused by *Heterodera radicum* have long been termed popularly, in this country, “root-knot.” In Scotland they are known as * “root-ill,” “thick-root,” “tulip-root,” “segging”; while in Germany they have long been known under the name “Wurzelgallen.” The tubercular swellings on the roots of leguminous plants (see comparison of root-galls with the tubercles of the *Leguminosae* at close of this section) have long been known and published in Germany as “Wurzelknöllchen” (root-knot). In order to avoid a confusion of the tubercle with the abnormal growths dealt with here I shall use the term nematode root-gall, or root-gall. There is a tendency with some writers to use the term “gall” only for those abnormal growths which have their

*Smith, W. G. Disease of Oats—*Heterodera radicum*, Muller, Gardeners' Chron., New Ser., Vol. XXVI, p. 172, 1886. Abstract in Bot. Centralblatt, Bd. XXXI, p. 247, 1887.

origin through the irritating presence of animals.* These nematode root-galls would belong to the same class of abnormal growths sometimes denominated *Helminthoecidien*. The writer does not mean by the use of the term root-gall that it has priority to the use of the term root-knot, but in view of the appropriateness of the word, teratologically, and for the reason stated above, he would recommend its adoption.

EXTERNAL CHARACTERS.—For the purpose of preparing the reader for a study of the life history and transformations of the parasite, section II was introduced, in which attention was called to the general external morphological characters of the galls in a few plants. It is now in order to discuss more at length the variations in form of the galls, and then to point out the special histological changes induced.

The external form of the gall is to a great extent dependent upon the number of worms and their distribution in the tissues of the roots, as well as upon some specific peculiarities in the growth of the roots or habit of branching. If the worms are numerous and the attack is made pretty regularly in a peripheral plane at a particular point in the root the gall will be symmetrical, and either short and ovoid or elongate and fusiform, according to the extent of their distribution along the axis of the root at that point. If fewer worms attack at a given point the gall is more likely to be lateral, owing to the less certainty of an even peripheral infection. Often, however, lateral galls may be so near as to unite into one, when the appearance is that of a very irregular and knotty gall, the enlargements passing by abrupt changes on different sides of the root.

For the forms of the galls in the roots of the tomato, potato and peach the reader is referred to Section II.

The galls found in the "poke-weed" (*Phytolacca decandra*) were very large, lateral and ovoid. In a species of the plant called coffee weed (*Cassia obtusifolia*) lateral galls were found on the tap root near the surface of the ground. On the grape the

*Sorauer, Pflanzenkrankheiten, Zweite Auflage, Heft, I.

fibrous roots usually possessed small ovoid lateral galls, while the galls on the larger roots were irregularly fusiform and not very prominent. The galls on the cow pea (*Dolichos catiang*) are quite peculiar. They are usually irregularly pyriform and mostly lateral, with the larger end of the gall below. When a root is attacked it appears in many cases to die just below the point of attack so that the gall is abrupt at this end while there is an opportunity for the worms to distribute themselves in a diminishing ratio a short distance above the gall, which makes the sloping narrowed portion of the pyriform body. The size and irregularity of the larger end of the gall is increased by one or more lateral roots, which develop very near the lower end of the gall, and continue the direction of growth of the main root which died. This in turn may be attacked, develop a gall, die below the gall and produce a branch, and so on, successively, until several pyriform galls are formed on successive branches, appearing like a string of pyriform beads, the string of which runs obliquely through them. In badly infected specimens this is more marked and presents a very singular appearance. The galls on bird's foot clover (*Lotus corniculatus*) are short and ovoid, or more usually, by the very close proximity of several, elongated and very irregular in outline. This irregularity is increased by the numerous small rootlets put out by the diseased root, into the bases of which worms distribute themselves and form small convex elevations on the larger gall.

In the roots of *Amarantus retroflexus* the worms were quite abundant, but the galls were not prominent. On the larger roots they were irregularly fusiform, slightly twisted, and while in some cases one-half inch, one inch or more in length, the diameter of the root was not greatly increased. In places the surface possessed small brownish or dirty white pustules, in which were cysts located very near or quite in the surface of the gall, while in the same gall other cysts were imbedded in the central cylinder.

It is unnecessary to detail further in this preliminary report the forms of the galls on the other diseased plants. Enough

has been said to show that great variation prevails and to give the typical forms about which all may be easily grouped. A list of the diseased plants which have thus far been found in this section will be given in Section VIII, while a comparison of the disease with some other characters and diseases of plants, with which it might be confounded upon external examination, will be made after the discussion of the microscopic details of the diseased tissues.

HISTOLOGICAL CHARACTERS (*See also references below**).—The worms locate preparatory to passing into the cystic state at various depths in the tissues of the root. They are not confined to any particular tissue element or system, but locate in the vascular tissue of the central cylinder, the cambium, parenchyma, or even in the bark, so that the body of the mature female cyst is frequently only protected by a thin layer of the dead peripheral tissue or sometimes is even exposed. They seem to flourish better, however, in or near the softer tissues of the root. It is a very common thing to find dead undeveloped female cysts, the majority of which I have always found in the woody tissue of the central cylinder. Possibly surrounded as they are by the harder, more compact tissue there is less certainty of the male reaching them for fertilization. This, however, is only a suggestion. I have not demonstrated it. All of the tissue elements in the diseased roots undergo hypertrophy, while some of them are subject to special changes in form as well as direction of growth.

The parenchyma cells which normally have their tangential diameter greater than the radial are so changed that the radial diameter is the greater. This change in form of the parenchyma cells seems to obtain in nearly all of the parenchyma in the gall

*Goodale, *Physiological Botany*, Vol. II, Gray's Botanical Text-books.
 Van Tieghem, *Traite de Botanique*, Deuxieme Edition, Fascicule 5.
 Muller, *Mittheilungen uber die unseren Kulturpflanzen schadliche, das Geschlecht Heterodera bildenden Wurmer*, *Landwirthschaftliche Jahrbucher*, Bd. XIII, Heft, I, 1884.
 Jahresbericht fur Wiss. Bot. (Just), 1876, p. 1235.
 Idem, 1877, pp. 516-517.
 Idem, 1878, p. 174.
 Idem, 1878, p. 169.
 Sorauer, *Pflanzenkrankheiten*, Zweite Auflage, Vol. I.
 Frank, *Krankheiten der Pflanzen*, and others.

whether very near a cyst or distant from it. The increase in number of the wood and vascular cells of the central cylinder takes place though the cyst may not be located in or very near it. In such cases the fibres and ducts have their normal longitudinal direction. But if a cyst is located in or very near the central cylinder the ducts are turned in their direction of growth perpendicular to the axis of the root, bent around the cyst and then converge on the peripheral side, when, left without any controlling influence over their direction of growth, they often perform very curious evolutions through the parenchymatous tissue in all directions.

A glance at Figs. 29 and 30, Plate V, will show at once a great difference in the arrangement of the tissue elements and the form of the cells of diseased roots compared with the same in a healthy root. These figures represent sections of roots of the cotton plant. Fig. 29 is from a section through a gall on a small lateral root, while Fig. 30 is from a healthy lateral root of the same size as the non-infected portions of the root from which Fig. 29 was taken. Both are drawn to the same scale and the natural size of the lateral root from which Fig. 29 was made is represented in Fig. 31. In the healthy lateral root (Fig. 30) it will be noticed that the differentiation of the woody tissue, which contains the large tracheal vessels, with the parenchyma is not so marked as in most roots so that the stellate appearance is not well represented. One of the most marked of the deformities is the displacement of the liber fascicles. In Fig. 30 they are shown in normal position at *e*. In Fig. 29 only one group is in what would be the normal position if the root were not diseased and of its normal size; this group is shown at *e*, Fig. 29; *e'*, *e'*, *e'*, *e'*, represent displaced groups; that is, in the rapid and abnormal increase of wood cells from the central cylinder they have been pushed far out of their normal position, while cells of the parenchyma on the one side and wood cells on the other have grown around the group *e*; *e''* represents one group not displaced but turned to grow in a tangential and radial direction, while *e'''* represents one group not only displaced, but turned also in a

tangential direction; *c* represents cells of vascular tissue which are turned in a tangential direction around the cavity of a cyst which is just below and was removed in making the section; *d* also represents cells of vascular tissue turned out of their normal course by the near presence of a cyst. At *a* is a cyst located in the edge of the vascular tissue of the central cylinder bordering on parenchymatous tissue; behind the cyst the cells of the vascular tissue are turned tangentially, and this part of the bundle reaches over outside of the parenchymatous tissue bordering the liber fascicle *e*. The parenchyma cells between the cyst and the liber fascicle *e* are elongated radially instead of having their tangential diameter the longer.

In Plate VI, Figs. 36 and 37 represent the structural character of the galls on tomato roots. The cysts *a* and *b* are seated in the parenchyma, the cells of which have long radial diameters and converge around the cyst. The parenchyma cells in this section, in a peripheral plane, are longer radially than tangentially. At *c* is represented a dead cyst, probably not impregnated, which lies in the woody tissue of the central cylinder. The pitted ducts can be seen to lie radially or perpendicular to the axis, turned from their normal longitudinal direction. Behind the cyst by turning in a tangential direction they converge from either side and meet.

Fig. 37 represents a section through a mature cyst lying in the vascular tissue: the cavity of the cyst at *a* is filled with eggs and young larvæ. At *b* are represented the vascular cells, which lie in a normal direction, cut transversely. On either radial side the ducts curve around, closely following the contour of the sides of the cavity. At *c*, the outer tangential side of the cyst cavity, the ducts from both sides and from below converge and meet.

Fig. 36 represents a section from a moderately sized young gall. In older ones, where the cysts are numerous, there is often presented an intricate maze of these pitted ducts coursing in all directions.

In potato tubers the parenchyma cells are elongated so that their longer diameter is perpendicular to the surface at that point

(see Fig. 38, Plate VI). When the potatoes remain in the ground for some time, or have been infested for some time during their growing condition, large warty growths are sometimes formed, as represented in the upper right-hand figure in Plate I. Again the tubers which have lain in the ground after maturity and sprouted ("volunteers") being badly infested, the young sprouts are attacked and large galls produced on them close to the surface of the tuber. In these cases pitted ducts are developed to a very great extent and a large majority of the mature female cysts are surrounded by an intricate net-work of these ducts. In making sections of such galls many of these cysts are cut through, and by removing the remains of the cyst there is the appearance of a beautiful microscopic basket woven from the ducts and imbedded in the looser parenchymatous tissue near by. In the galls of the peach root, beside the special structural derangements which could be classed under the head of the foregoing characters, there appears in many of the nearly mature or old female cysts a secondary growth of pseudoparenchymatous tissue from the inner periphery of the cavity, which in some cases nearly fills the cavity with tender, loosely compacted cells, so that the cyst is often deformed by the pressure of these ingrowing cells, and in very old ones the larvæ lie in different places in the tissue. It requires in some cases very careful search to find a female cyst which can be removed and recognized as the female of *Heterodera*.

COMPARISON OF THE EXTERNAL APPEARANCE OF THE ROOT-GALL DISEASE OF THE POTATO WITH "POTATO SCAB."— In some of the peculiarities of the disease in the potato tubers caused by *Heterodera radicum* there is a striking resemblance, especially in the earlier stages, to the effects of the disease called "potato scab" and attributed by Brunchorst* to the action of a parasitic organism of very simple structure which he calls *Spongospora Solani*, and considers to be closely allied to the organism called by Woronin† *Plasmodiophora Brassicæ*, which causes the

*Ueber eine sehr verbreitete Krankheit der Kartoffelknollen. In Bergens Museums Aarsberetning for 1886, p. 219.

See also "Potato scab," J. E. Humphrey, Mass. State Exp. Station, 6th Annual Report, 1888.

†Pringsheim's Jahrbucher fur wissenschaftliche Botanik, Vol. XI, p. 548.

disease of cabbages and turnips vulgarly known as "club-foot." The surface of a healthy potato is quite smooth with here and there minute rounded elevations which are usually of a little lighter color than the ground color of the surface and slightly roughened or granular. These are known as the "lenticels," the cork cells of which being loose and rounded have many intercellular spaces and permit an easy interchange of gases between the cells of the potato and the outside. It is supposed that the potato scab disease begins in the vicinity of these lenticels. An increase in the tissue of the potato takes place here, so that a low convex elevation is formed, the surface of which becomes "scurfy" by the peeling off of the outer coats. From this the tissues break down and decay sets in, and unless the disease is arrested the whole surface of the potato is affected. It appears that the larvæ of *Heterodera radicum* mainly attack a potato in the vicinity of these lenticels, for the first external sign of the presence of the parasite is the enlargement of these lenticels until elevations of considerable size are formed, which are scurfy on the surface. Finally the elevation cracks, decay sets in and in many cases the external appearance strongly resembles a "scabby" potato. Usually, however, when the disease is arrested the tissues being softened gradually shrivel and the potato has a wrinkled and shriveled appearance which I never saw in a potato affected by what is called the "scab." Usually also the roots will present the irregularly fusiform or ovoid galls. For the purpose of comparing "scabby" potatoes with those infested by the *Heterodera* requests were made of several gentlemen in Alabama and in some of the Northern States for "scabby" potatoes from their respective sections. Specimens were received from Peter Collier,* Director of the New York Agr. Exp. Station at Geneva, N. Y.; from Prof. E. S. Goff, Horticulturist of the Wisconsin Agr. Ex. Station at Madison, Wis.; from Mr. Clarence M. Weed, Entomologist of the Ohio Agr. Exp. Station at Columbus, Ohio; from Mr. Wilson Newman, Assistant Director

*The author wishes to express his obligation to these gentlemen for their kindness.

of the Canebrake Station, Uniontown, Ala., and from Prof. T. M. Watlington, Abbeville, Ala.

From the last named place the specimens received were very badly infested with the *Heterodera radicum*, and with a few of the nematodes which cause the disease described by Prof. Scribner.* I did not find the *Heterodera* present in the potatoes from any of the other localities. When the potatoes remain in the ground for a long time the fissures in the elevations become so deep and in some places the corky growths are so large and prominent as to be easily distinguished from the appearance of "scab" in any of the potatoes the writer has seen. In Plate I the upper left-hand figure represents the very early stages of the disease caused by *Heterodera radicum*, while the upper right-hand figure represents one which has long been infested.

COMPARISON OF ROOT-GALLS WITH "CLUB-FOOT" OF CABBAGE.—It will be of great interest to compare the diseased condition of the cabbage roots caused by *Heterodera radicum* with the disease of the roots vulgarly known as "club-foot" of cabbage, since in many respects the external characters are very similar, while the two diseases are caused by very widely different organisms. The one which causes root-gall, *Heterodera radicum*, is, when compared with organisms of a lower grade, an animal of quite a complex and high organization. The one which causes "club-foot" is one of the slime moulds, a plant of the very lowest organization, called by Woronin,† who first discovered it to be the cause, *Plasmodiophora Brassicæ*. This parasite, when in its mature state, consists of numerous very minute rounded bits of protoplasm, each independent and protected by a thin covering or wall. These remain in a resting condition through the winter in the diseased roots or in the soil. In the spring by decay of the roots these spores are freed. Under proper conditions of temperature and moisture they absorb water until the wall cracks and the bit of protoplasm is set free as a swarm cell; that is, a microscopic bit of plastic protoplasm with

*Bulletin Agr. Exp. Station, Tenn., Vol. II, No. 2, 1886.

†Pringsheim's Jahrbucher für wissenschaftliche Botanik, Vol. XI, p. 548.

a very slender cilium or hair-like process. After a time it loses this cilium and then the plastic bit of protoplasm moves slowly about in the damp soil by a streaming movement in various directions. It is capable of streaming out in such very fine threads as to enter the roots of the cabbage along with watery solutions of nutriment. Once within the root it locates in a cell and commences to appropriate the living matter of the root to itself. In this way it grows in size, still remaining a very plastic body of simple protoplasm. Thousands of these enter the roots of a single cabbage. Not only do they appropriate to themselves the living matter of the root, but they cause the root of the cabbage to produce an increased number of cells, so that oval or fusiform enlargements are formed. The cells of the root in which these parasitic masses of protoplasm are seated increase greatly in size compared with those which do not contain the parasite. The plasmodium, for so this mass of protoplasm is called, is yellowish in color. Late in the season it divides up into countless minute bits of protoplasm, each of which secretes a protective wall about itself, and its life cycle is completed. The diseased cabbages become sickly, turn yellowish and either die or do not head.

Now in external appearance these enlargements of the roots, which are called "club-foot," very much resemble the enlargements called root-galls, which are produced by the nematode. Unless one was pretty certain of the locality from which the diseased specimens came and knew the history of the disease in that locality it would be venturesome to undertake to say whether it was root-gall or "club-foot" until after a microscopic examination of the parasite or of the structural characteristics of the diseased root.

I have some very fine specimens of "club-foot" before me which I obtained from Eastern North Carolina nearly a year ago. Having been placed in strong alcohol the enlargements are a little wrinkled and shriveled. But so closely do they resemble, especially in a fresh condition, the root-galls that when I collected specimens of cabbages here this autumn with enlarge-

ments on the roots I expected to find *Plasmodiophora Bassica*, until after I had made the microscopic examination and found the cause to be a worm. Perhaps the enlargements of "club-foot," before they begin to crack, are a little more even in contour than those of root-galls, and in the specimens I have seen those of "club-foot" are larger, especially on the tap root, where very large lateral growths are formed. But if we take a thin transverse section of an enlarged root of each and compare them all resemblance vanishes. In a cross section of "club-foot" the first thing to attract attention is the great number of yellowish plasmodia, or else the spore masses within large cells, distributed all through the tissues. If the section is from an enlargement of a lateral root, unless very large, there will be little else to attract the attention when compared with a healthy root, unless it be a slight enlargement of some of the other cells. The general character of the root structure is but little changed. The tracheal tissue of the axis cylinder, but little attacked, is arranged in the same stellate form which we find it in a healthy root. The ducts, even when immediately in contact with cells containing plasmodia, are not turned from their longitudinal direction, or if so, only slightly. The cells are not elongated and curved around the enlarged cells containing the plasmodium, but resemble the normal arrangement of small cells around a large one. Nor is the radial diameter of the parenchymatous cells proportionately increased, but if the cells are enlarged it is usually a proportionate or nearly symmetrical enlargement. In this section from the root-gall here and there is a cyst, or the amorphous remains of one containing eggs and larvæ. The color is not so yellowish as that of the plasmodia nor are the cysts so numerous. Indeed the most striking feature in the appearance of the cross section is the twisted, curved and distorted condition of the cells, especially of the tracheal vessels. In some places these are beautifully wreathed about a cyst, and by their side run very much elongated parenchyma cells, while in another place a labyrinth of vessels is woven with the parenchymatous tissue, giving to the section as a whole, viewed with the compound microscope, the

appearance in miniature of a heavy field of grain after a driving storm, when the stalks of grain are twirled in all directions and matted in inconceivable ways.

When very large lateral "clubs" are formed, as on the tap root, the tracheal tissue is turned in an outward direction and curved in various ways. But even then it is confined to more or less recognizable bundles, is rarely sharply curved, and never is wreathed around the plasmodia as around the cyst in the root-gall.

COMPARISON OF THE ROOT-GALLS WITH THE "TUBERCLES" OR "WURZELKNÖLLCHEN" OF LEGUMINOUS PLANTS.—To remove all possibility of a confusion of the root-galls with the tubercles (or Wurzelknöllchen) of the *Leguminosæ*, which has probably sometimes occurred, this comparison is introduced.

These tubercles, which recent experiments* seem to show play an important role in the acquisition of atmospheric nitrogen by leguminous plants, are irregularly oval enlargements of the roots, from the size of a pin-head to a large pea, or sometimes elongate or clavate and very much branched and convoluted. The root-galls will usually not be mistaken for the tubercles by one familiar with these bodies. The tubercles are formed only on the very youngest roots, so that they are connected with the root from which the diseased one branch by a very slender attachment. Sometimes, however, the attachment is very stout. Usually the surface of the tubercle, though it may be greatly convoluted or lobulated, is smoother and does not present the scurfy or cracked appearance so common, especially in age, on the surface of the root-galls. The root-galls may occur on proportionately large roots, and in a majority of cases the attack is made some distance from the end of the root, so that the root continues to grow beyond the gall and several galls may be found on the same

*Atwater, W. O. Atmospheric Nitrogen as Plant Food, Bulletin No. 5, Storrs' School Agr. Exp. Station Conn., Oct., 1889.

Bertholet, M. Experiences Nouvelles sur la fixation de l'azote par certaines Terres Vegetales et par certaines plantes. Ann. de chim. et de Phys. 6me serie, T. XVI, Avril, 1889.

Hellriegel und Wilfarth, Untersuchungen über die Stickstoffnahrung der Gramineen und Leguminosen. Beilagehaft z. d. Zeitsch. d. Ver. f. d. Rubenzucker-Ind. d. D. R. Berlin, 1888.

Abstract in Bot. Centralblatt, Bd. XXXIX, pp. 138—143, 1889.

root in succession. The root also continues to enlarge so that few of the galls are attached by such slender pedicles as the attachments are in the case of tubercles I have seen. Since the tubercles vary greatly on the roots of different species* there are probably cases in which it would be difficult, from an external examination, to say whether the enlargements were root galls or "tubercles." The structural characters are, however, so very different that it will not be out of place here to note briefly the chief structural characters of the tubercles and give a short *resume* of the leading opinions regarding their function.

Very different views have been entertained from time to time as to the nature and significance of these tubercular swellings. The interior of these tubercles is composed of a loose parenchymatous tissue. In the younger parts of this tissue all observers agree as to the presence of strands or threads of a very plastic nature, with no cross partitions, which course between and through the cells, often sending short flask-like branches into the cells. These possessing a resemblance to the strands of *plasmodia* or threads of certain fungi, were so regarded by Ericksson,† Kny,‡ Frank,§ Lundström.|| In the older parenchymatous tissue all agree in observing in the plasmic contents of the cells bacteria-like bodies of variously branched forms, forked, or Y and X forms. These were regarded by Woronin¶ and others as bacteria. Brunchorst** believed the tubercles (*Knöllchen*) were normal structures, and that the bodies which Woronin and others assumed to be bacteria were formed by a differentiation of the plasmic, protein contents of the cells into these forms, since they were found to be very rich in protein matter, and not accepting them

*Sorauer. Pflanzenkrankheiten. Zweite Auflage. Erster Band, p. 743.

†Studien over Leguminosernas rotknolar, Lund, 1874; Bot. Zeitung, S. 381, 1874, cited by Sorauer, Pflanzenkrankheiten, Zweite Auflage, Erster Band, p. 744, and by Frank, Krankheiten der Pflanzen, Zweite Hälfte, p. 650, 1881.

‡Sitzungsber. d. bot. Ver. d. Prov. Brandenburg, 28 April, 1878; cited by Sorauer (l. c.).

§Krankheiten der Pflanzen (l. c.).

||Ueber Mykodomatien in den Wurzel der Papilionaceen. Bot. Centralblatt, Bd. XXXIII, pp. 159, 160 and 185—188, 1888.

¶Mem. Acad. imp. de Scienc. d. St. Petersbourg, X, 1866. Cited in Sorauer, Pflanzenkrankheiten (l. c.).

**Ueber die Knöllchen an den Leguminosenwurzeln. Bericht. d. Deutschen bot. Gesellschaft, Bd. III, pp. 241—257, 1885. Abstract in Bot. Centralblatt, Bd. XXIV, pp. 333, 334, 1885.

as bacteria he called them “*bakteroids*.” He regarded the “*bakteroids*” as reserve material which at fruiting time was absorbed by the plant. Supporters of this view were found in Schindler,* Tschirch† and others. Many observers have noticed in these plasmic “strands” or fungal hyphæ (*hyphenpilzen*) minute rod-like bodies very closely resembling bacteria. These were first called bacteria by Beijerinck,‡ who regarded the plasmic strands in which they were found as the remains of nuclear division in the cells of the tubercle. Ward§ regarded these “strands” or “hyphæ” with their contained rod-like bodies as fungi in some respects resembling the smuts, or *Ustilagineæ*. Vuillemin|| also believed the tubercles to be caused by a fungus, but classed it with the *Chytridiaceæ*, with affinities for the genus *Cladochytrium*, and he named it *Cl. tuberculosum*. He claims to have studied the sporangia and zoöspores. Prazmowski¶ first considered the tubercles to be caused by a parasitic fungus in some stages resembling *Plasmodiophora Brassicæ*, Wor., but after later researches|||| he comes to the conclusion that the organisms in question are bacteria.

One of the most interesting of recent views, and that held by Prazmowski, Ward, Vuillemin (*l. c.*) and others, supported also by the best experimental evidence, is that certain microorganisms, either fungi of a very simple organization or bacteria, by an endoparasitism produced the abnormal growths, and for a time live at the expense of the host plant, but being locked

*Ueber die biologische Bedeutung der Wurzelknollen bei den Papilionaceen. Jour. f. Landwirth. Henneberg, XXXIII, pp. 325—336.

Abstract in Bot. Centralblatt, Bd. XXVII, pp. 108, 109, 1886.

†Beiträge zur Kenntniss der Wurzelknollen der Papilionaceen. Bericht. d. Deutschen bot. Gesellschaft, Bd. V, 1887. Cited by Sorauer, Bot. Centralblatt, Bd. XXXI, p. 308.

‡Die Papilionaceenknollen, Bot. Zeit., p. 726, 1888. Abstract in Bot. Centralblatt, Bd. XXXVIII, No. I, pp. 458, 459, 1889.

§On the tubercular swellings on the roots of *Vicia Faba*. Philosophical transactions, Roy. Soc. London, Vol. 178, B., pp. 539—562, 1887. Abstract in Bot. Centralblatt, Bd. XXXIV, p. 305, 1888.

||Les tubercles radicaux des Legumineuses. Ann. des. Sc. agron. franc. et etrang. 8°, p. 96, 1888. Abstract in Bot. Centralblatt, Bd. XL, pp. 123—125, 1889.

¶Ueber die Wurzelknollen der Leguminosen, Bot. Centralblatt, Bd. XXXVI, pp. 215—219, 218—255, 280—285, 1888.

||||O istocie i znaczeniu biologicznem brodawek Korzeniowych grochu. Bericht aus den Sitzungen der k. k. Akademie der Wissenschaften in Krakau, Juni, 1889. Das Wesen und biologische Bedeutung der Wurzelknollen der Erbse, Bot. Centralblatt, Bd. XXXIX, pp. 356—362, 1889.

within the peculiar structure of the tubercle dissolution of their bodies takes place, followed by an absorption of their protein contents by the plant, so that not only nearly all of the substance which the plant yielded to the parasitic organism is thus finally restored, but in addition a more costly element, atmospheric nitrogen, which the organisms have assimilated and prepared for their host.

The chemical and physiological researches of Hellriegel and Wilfarth,* Berthollet† and Atwater‡ show that the plants with tubercles on their roots grown in a soil with very little nitrogenous substance gain more nitrogen than the soil contains, but when grown in a sterilized soil no such gain is made. The experimental researches of Prazmowski (*loc. cit.*) were directed to the biological nature of the parasitic organism as well as to proving that they were the specific cause of the tubercles. The plants experimented with were peas, but he draws the inference that the rest of the "Papilionaceen" are not essentially different in the character of their tubercles.

In brief, the results of his later researches§ are as follows: The root-knots (Wurzelknollchen) of peas are not normal structures, for in sterilized media, protected from accidental infection, they are never formed, but they always result from infection.

The infecting knot-organisms are bacteria identical with them in form and characters. The bacteria were taken from young knots and increased through many generations by culture in nutrient media. The causal connection between the bacteria thus isolated and the root-knots was proven by a long series of careful experiments wherein infection was produced through the inoculation of cultivated plants with bacteria, originally taken directly from the knots, and cultivated through many generations. The

*Untersuchungen über die Stickstoffnahrung der Gramineen und Leguminosen. Beilagehaft z. d. Zeitsch. d. Ver. f. d. Rubenzucker-Ind. d. D. R. Berlin, 1888. Abstract in Bot. Centralblatt, Bd. XXXIX, pp. 138—143, 1889.

†Experiences Nouvelles sur la fixation de l'azote par certaines Terres vegetale et par certaines plantes. Ann. de Chim. et de phys. 6 me. serie, T. XVI, Avril, 1889.

‡Atmospheric Nitrogen as Plant Food. Bull. No. 5, Storrs' School Exp. Sta. Conn., Oct., 1889.

§Berichte aus den Sitzungen der k. k. Akademie der Wissenschaften in Krakau, Juni, 1889.

Bot. Centralblatt, Bd. XXXIX, pp. 356—362, 1889.

formation of the knots occurs only on the youngest roots and their branches.

The knot-bacteria make their way through young cell-membranes into the root-hairs and epidermal cells of the root and multiply there at the expense of the plasmic contents of the cells. After the bacteria have increased to considerable extent in the root-hair they unite near the point into grape-like clusters of colonies which lie very close together, become enveloped in a tough, glistening membrane by means of which they are united with the cell membrane of the root-hair. There arises now near the point of the root-hair, on the inside of its wall, a glistening knob-like projection. Around this bacteria knob curls the end of the root-hair in the form of a shepherd's crook, or of a screw. Out of this enveloping screw at the base of the root-hair grows the bacteria-knob as a hypha-like or thread-like tube, which is surrounded by a glistening membrane and filled with bacteria. From this time on until the formation of the knot and the differentiation of its tissue the bacteria-tube resembles a real non-septate fungus filament; it grows at the apex and produces branches.

After growing out of the enveloping root-hair the bacteria-tube enters the epidermis of the root, pierces the rind and grows sometimes so deep as the endodermis of the central cylinder. In its growth and branching it passes between the cells, splitting the membrane between two cells and crowding the two lamellæ apart, forming more or less prominent distended places in the tube, the outside of which is bounded by the two lamellæ and the inside filled with bacteria. The bacteria-tubes also send short branches through the cell membranes into the cells which grow towards the nucleus were formerly considered to be haustoria, and in unstained preparations are very difficult to distinguish from the cell contents. These Beijerinck* took to be the remains of nuclear division. In the early stages of the development of the knot no bacteria are found free in the contents of the cells; they are all enclosed in the bacteria-tube.

*Die Papilionaceenknollchen, Bot. Zeit., p. 726, 1888. Abstract in Bot. Centralblatt, Bd. XXXVIII, pp. 458, 459, 1889.

In consequence of the presence of the bacteria-tube in the deep layers of the rind the cells lying near begin to increase in number by division, slowly at first, but soon in rapid succession. At the same time the bacteria-tube grows into this newly formed tissue and branches profusely. Following this division of cells there arises at this point a meristematic or growing tissue which through rapid increase becomes of considerable size, in which now the characteristic tissue of the knot is differentiated. In the midst of this meristematic tissue there arises a parenchymatous tissue, of large cells, into which the bacteria-tube grows and branches profusely in all directions. Later, through the dissolution of the tube the bacteria are set free in the parenchymatous tissue, which now becomes the so-called "bacteroid tissue." The outside of the knot is differentiated into the rind, a few layers of cells with little plasmic contents disposed radially, the outside layer of which becomes corky. Between the bacteroid tissue and the rind is a zone of small-celled tissue capable of division and growth and free from bacteria, the meristem or growing point of the knot. On the inner periphery of the meristem a zone of fibrovascular bundles is formed, which originates as branches from the central cylinder of the root. Between the fibrovascular zone and the bacteroid tissue a layer of starch containing cells exists. As the knot or tubercle enlarges the meristematic zone by growth advances in a peripheral plane. The peripheral part of the parenchymatous or bacteroid tissue also continues to advance by growth, and the peripheral part being younger contains the bacteria-tubes with their rod-like bacteria contents, and these bacteria-tubes continue to grow and follow up the advancing peripheral portion of newly formed parenchymatous tissue, while behind follows up the process of dissolution of the membrane of the tube and the liberation of the bacteria into the plasmic contents of the cells making the bacteroid tissue.

From several series of experiments conducted with every precautionary measure he reaches the conclusive proof that by means of infection with knot-bacteria the plants (peas) even when grown in a soil deprived of all nutriment and providing for the

exclusion of all other organisms, could provide the necessary nutriment from the store of nitrogen in the atmosphere. But whether from nitrogen in combination, or, as Hellriegel (*l. c.*) claims, from the elementary nitrogen of the atmosphere, the researches have not yet been carried far enough to say.

If bacteria taken out of the knots in peas are cultivated in suitable nutrient media they increase for an unlimited time by fission, retaining a rod-like form. In the knots under the influence of the plant they increase in the same way and possess the same form until the time when dissolution of the membrane of the bacteria-tube takes place and they are set free in the bacteroid tissue. In the plasmic contents of the cells of the bacteroid tissue they increase for a time, but change their form and branch in a forked manner forming X and Y forms. At last their bodies become hyaline and dissolution takes place. The plant begins to empty the older cells of the bacteroid tissue by appropriation of their contents for its own use. The time when this absorption of the contents of the bacteroid tissue begins and the energy with which it proceeds bears a distinct relation to the amount of nitrogenous matter in the soil at the command of the plant. When the soil is well supplied with it the knots grow to considerable size, the bacteroid tissue is filled with bacteria and bacteria-tubes and presents a flesh-red color, and remains in this condition until the maturity of the plant. The dissolution of the bacteroids and the emptying of the bacteroid tissue proceeds very slowly and irregularly. On the other hand, when there is a scarcity of nitrogenous matter in the soil at the command of the plant the dissolution of the bacteroids and the emptying of the bacteroid tissue begins early and proceeds rapidly while the bacteroid tissue has a greenish color.

In both cases the emptying begins in the oldest part of the bacteroid tissue and advances towards the meristematic zone. Even in the oldest part of the bacteroid tissue remain numerous living bacteria and tubes containing bacteria, which, with those in the peripheral zone of the parenchymatous tissue escape into the ground upon the decay of the knot and there increase and perpetuate the infectious character of the soil.

In knots partly eaten by insects, which is quite common, the masses of bacteroids become surrounded anew by a membrane and the bacteria-tube thus formed by sprouting divides into successively smaller colonies surrounded by membranes, which Prazmowski first took to be a kind of spore formation when the real nature of the organisms were unknown to him.

The structure of the knot is adapted to favor the symbiotic relation which exists between the host plant and its parasite. The corky layer of the rind prevents not only the ingress of foreign organisms, but prevents the escape of the bacteroids, while the fibrovascular tissue which surrounds the bacteroid tissue provides the channel of communication between the plant and the contents of the knot. The plant being the master imprisons the bacteroids within the tissues of the knot, for a time nourishes them with the material which is the product of carbon assimilation in the leaf and the willing bacteroid slave assimilates atmospheric nitrogen producing protein matter, when finally the plant completely overpowers them, dissolves their bodies and carries off their protein contents for its own use.

VII.

TREATMENT.

The following discussion of the treatment of the root-gall nematode is mainly suggestive, and anything farther must be preceded by careful experimentation.

DIFFICULTY OF REMEDIAL APPLICATIONS TO PLANTS ALREADY DISEASED.—It is evident from the endoparasitic habit of the worms that direct applications of vermicides to the roots will not destroy them without fatally injuring the plants themselves. When the worms first enter the tissues of the roots they are so minute that no channel is left large enough for the entrance of any poisonous fumes which might be applied in the soil. Also the hypertrophy of the tissue of the roots incident upon the presence of the parasites would effectually close up any aperture made. Dr. Neal,*

*Bulletin 20, U. S. Dept. Agr. Division of Entomology.

in some experiments conducted by him under the direction of Dr. Riley, has shown that the application of bisulphide of carbon, kerosene emulsion and various arsenical solutions, in quantities sufficient for the destruction of the worms, was generally fatal to the plants themselves, while the use of alkaline fertilizers, like hard-wood ashes, muriate and sulphate of potash, kainite, etc., produced a hard growth less susceptible to attack.

STERILIZATION OF THE SOIL BY STARVATION.—The cheapest and probably at the same time the most effectual mode of sterilizing the soil will be to starve out the worms by a rotating system applied to the selection of fields or plats of ground upon which are grown only such plants as are positively known to be insusceptible to attack. A real difficulty arises even here, for so many plants in widely different families are known to be susceptible to the disease, and plants that are absolutely insusceptible can in some cases only be determined after a series of trials. Dr. Neal reports (*loc. cit.*) that according to his experience *Amarantus spinosus* is the “most dreaded and destructive agent in the spread of the root-knot.” In this section, even in the immediate neighborhood of other plants badly diseased, I have found this species free, so far as examined, while *Amarantus retroflexus* growing side by side with it is diseased. Similar cases in the habit of a related species of *Heterodera* (*H. Schachtii* Schmidt) are reported from Europe. This species is very destructive to sugar-beets and many other plants. Among a number of plants which were supposed to be insusceptible was barley.* Upon a piece of land very badly infected by the “Rübennematode” barley was sown for three years successively. The first two years no injury was noticed, but in the third year the crop was destroyed a short time before harvest by severe attacks of the worms. Dr. Neal (*loc. cit.*) also speaks of the Japan Clover (*Lespedeza striata*) as a substitute for the cow-pea (*Dolichos catiang*) as a forage plant and fertilizer. In this vicinity *Lespedeza striata* ranks as one of the species slightly affected, while “bird’s-foot clover” (*Lotus corniculatus*) is very badly affected. It is evident that

*Quoted from Sorauer, Pflanzenkrankheiten, Zweite Auflage, Vol. II, p. 853.

thorough investigations must be made to determine the useful plants which are very nearly or quite insusceptible to the attacks of the worms. By growing such crops upon selected ground for a period of a few years, exercising at the same time great caution in not allowing any weeds or grasses, which may be susceptible, to grow, the area selected could be sterilized. Now by taking up successively different areas and treating them in the same manner a persevering farmer could practically rid his land of the worms. So far as observed here buckwheat and alfalfa are among the insusceptible plants which could be experimented with.

ROTATION OF CROPS.—Here we find occasion again to emphasize the oft-repeated necessity of a judicious rotation of crops, but with special reference to a wise alternation of insusceptible with susceptible plants. It is evident that if we start with a sterilized soil and grow for one year an annual which is liable to the disease there is little danger of infection of the ground. If the following year this is followed up by the cultivation of another nearly or quite free from attack the soil will with greater safety bear another crop of the plant grown the previous year.

CLEAN CULTIVATION.—The absence of clean cultivation is one of the most fruitful sources of the thorough impregnation of the soil with the worms. It was, of course, impossible to make an application of this principle to the enemy in question before that enemy was known, and especially before the time required for its complete development from the egg had been determined. Now that these facts are known, and since we know many of the plants subject to the disease, it is to be hoped this method will be employed by those desirous of subduing the worms. Not only should an effort be made to prevent the growth on arable land of all plants growing wild which are liable to serious infection, but so soon as a crop has been gathered, or it is found that the crop will not be worth gathering, from any cultivated plant liable to serious infection the farther growth of the plants should be stopped, or, what is better, the roots of the plants should be gathered and burned when possible. In gardens this would not

be a serious task compared with the benefit to be derived. I have noticed cabbages, tomatoes and potatoes, all which are seriously susceptible to the disease, growing in an abandoned condition for two months in the latter part of the season, all the while providing for the rapid development and multiplication of the parasites. During this time two successive generations of the worms are developed. Each female egg would, on the average, making no allowance for fatalities, produce in the first generation 200 young. Allowing 50 per cent. of these for males there would be 100 to start the second generation for every one at the beginning of the first. These would, then, on the basis of a similar computation produce 20,000 young, or 10,000 females to be the producers of the third generation. Then during the time of the abandoned growth of these diseased plants every productive parasite has produced 10,000 productive parasites.

TREATMENT OF PERENNIALS.—The greatest care should be exercised in the cultivation of perennials like the grape, peach, fig, etc. The young plants should be obtained from sources where it is known they have been grown in non-infected soil. The orchard or graperies should be selected and by a system of cultivation of insusceptible plants be rendered sterile by starving out the worms. Then the practice of cultivating either for forage or as a fertilizer plants liable to the disease in the orchard should be discontinued. Where orchards or graperies are so seriously injured as to interfere with the productiveness of the trees or vines they might be preserved for a few years while the orchard is renewed in soil freed from the worms, when they should be destroyed.

The peach-trees and grape-vines which I have examined in the vicinity of Auburn, while slightly affected do not appear yet to suffer any serious consequences. Young tree and seedlings are more seriously affected. The most badly diseased grape cuttings I have seen were those grown very near diseased cabbages and tomatoes. Care should also be used in the cultivation of seed potatoes which are not infected.

TRAPPING THE WORMS.—In Germany cultivators of the sugar-beet have resorted, with a degree of success, to trapping the worms of a related species (*H. Schachtii*)* from badly infected soils by the cultivation of plants very susceptible to the disease, and then gathering the roots before the worms are fully developed and destroying them. Such plants they call “catch plants” (“Fangpflanzen”).

COMPOSTS. — If roots are ever used in the making of composts great caution should be used, since there is danger of infecting soil hitherto free from the worms by fertilizing such land with compost material containing diseased roots. Kühn† has shown that such infection does take place in the case of a related species, *Heterodera Schachtii* Schmidt, and also states that the material may be rendered innocuous by placing unslacked lime in layers with the infected refuse of plants which may be used in compost. For distributions, see close of Section V.

VIII.

PLANTS AFFECTED.

The following list of plants affected with the nematode root-galls is by no means complete. It comprises only such as with limited time I have been able to determine thus far in the vicinity of Auburn. From the foregoing study and comparison of the root-galls with externally similar teratological root growths it will be seen that two essential characters must be determined before in all cases we can say the abnormal growth is a nematode root-gall: a microscopic examination to detect the presence of the worm and the histological changes accompanying its parasitism. Both of these tests have been applied in making up this partial list. Those marked with a * are badly affected:

*Sorauer, Pflanzenkrankheiten, Vol. 11, p. 854.

†Die Ruben Nematode. Zeitschrift des landwirthschaftlichen Central-Vereins der Provinz Sachsen, No. 12, pp. 332—335, 1870.

1. *Amygdalus Persica* (peach).
2. *Ficus Carica* (fig).
3. *Vitis vinifera* (grape, several varieties).
4. **Solanum tuberosum* (potato).
5. *Solanum esculentum* (egg plant).
6. **Lycopersicum esculentum* (tomato).
7. *Physalis* sp.
8. **Abutilon* sp.
9. *Gossypium herbaceum* (cotton).
10. *Hibiscus esculentus* (okra).
11. *Sida spinosa*.
12. *Modiola multifida*.
13. *Cassia obtusifolia* (coffee weed).
14. **Dolichos catiang* (cow pea).
15. *Phaseolus*.
16. *Lespedeza striata* (Japan clover).
17. **Lotus corniculatus*† (bird's-foot clover).
18. *Melilotus alba*.
19. *Ipomœa tamnifolia*.
20. *Ipomœa lacunosa*.
21. *Clematis* sp.
22. *Phytolacca decandra*.
23. **Helianthus annuus* (sunflower).
24. **Citrullus vulgaris* (water-melon).
25. **Cucumis melo* ("nutmeg melon," "citron").
26. *Beta vulgaris* (beet).
27. *Amarantus retroflexus* (spineless careless weed).
28. *Chenopodium Anthelminticum* (worm seed).
29. *Zea mays* (corn).
30. **Brassica oleracea* (cabbage).
31. *Brassica Rapa* (turnip).
32. **Brassica campestris rutabaga* (rutabaga).
33. *Marrubium vulgare* (horehound).
34. **Pastinaca sativa* (parsnip).
35. *Lactuca sativa* (lettuce).
36. **Tragopogon porrifolius* (salsify).

†Determined by Dr. G. W. Vasey.

EXPLANATION OF PLATES.

[All the Plates are original, and except the first two, which are from photographs, were drawn by the author from nature. In Plates IV, V and VI all the figures are magnified except 31 and 32.]

PLATE I. IRISH POTATOES (*Solanum tuberosum*).—The cracks in the large potato (seed potato) result from the increased growth of cells at the points where the Heterodera exists. The upper left-hand figure is a small young potato taken from this same plant, the elevations and projections caused by presence of the Heterodera. The enlargements on the roots of the potato are the galls. (Natural size, from photograph).

PLATE II. Tomato root showing root-galls two-thirds (natural size, from photograph).

PLATE III. Parsnip and Salsify, showing root-galls, natural size.

PLATE IV. Development and transformation of *Heterodera radicumicola* (Greef). Müll.

Figs. 1—9, different stages in segmentation of mature eggs; 10, invagination at anterior pole; 11, young embryo of the length of the egg, beginning to elongate and coil inside of the egg membrane, the caudal end, which is below in the figure turning toward the ventral side, the cephalic end, above, granular and nearly hyaline; 12, 13, 14, farther elongation of embryo; 15, mature larva coiled five times within the egg membrane.

Fig. 16. Larva coming from egg membrane and moulting at same time, the partially cast skin can be seen slipped from the head and tail. At the boundary between the hyaline and strongly granular portion near the tail end can be seen the anal opening.

Fig. 17. Sexually immature worm, larva: 17x, same, not so greatly magnified in one of the various forms sometimes found prior to the cystic state; 18, 19, 19z, various degrees of distention of the larva; 20, young female cyst, showing ovaries; 21, male undergoing metamorphosis; 21x and 22, same with metamorphosis complete, in pupa state; 23, emergence of sexually mature male from cyst; 24, front view of head of male showing the position of the lamellæ around the spear; 25, anterior end of female, *a* exsertile spear, *b* anterior part of the œsophagus; 26, posterior end of a male (see page 103), *a* caudal appendage (probably an accidental variation), *b* spicules; 21z sexually mature male very greatly magnified, showing the paired testes.

Fig. 27. Mature female cyst, *a* middle part of œsophagus (suctorial bulb), *b* anterior part of œsophagus, *c* exsertile spear, *d* vulva, *e* genital tubes, the anterior ends of which form the ovaries.

Fig. 28. Genital tubes of female cyst with mature eggs still farther enlarged; *a* vagina; the uterus extends from the vagina a little more than one-third the length of the tube, near the middle is the *receptaculum seminis*, the oviducts and ovaries occupy a little more than one-half of the free ends. The small ova are very tender and flexible, but by pressure of the mass are held in a polygonal form within the ovaries. If the ovary is broken at a point as at *b* or *c* the young ova escape and assume a spherical form, and not yet being free cells are held together in a beautiful cluster as represented in the figures. As the young ova increase in size by growth the pressure causes them to move toward the oviducts, they

gradually develop numerous yolk globules which darken their appearance, passing through the *receptaculum seminis* are fertilized, and entering the uterus segmentation begins, finally the mass of developing eggs in the genital tubes ruptures them and the eggs and embryos are set free within the body of the cyst.

PLATE V. Structural effects of the disease in roots of cotton and peach.

Fig. 29. Cross section of gall on lateral root of cotton plant; *a*, female cyst showing ovaries, etc.; *b*, old female cyst showing eggs and young larvæ in the amorphous remains of the parent; *c*, deformed vascular tissue by the side of a cyst; *d*, deformed vascular tissue, the tubes turned in a radial and tangential direction to the axis of the root; *e*, liber fascicle in normal position of healthy root; *e'*, liber fascicle displaced, and, by increased growth of parenchyma and vascular tissue, carried far out from normal position; *e''*, liber fascicle deformed and growing in a radial direction; *e'''*, liber fascicle displaced and growing in a tangential direction.

Fig. 30. Cross section of healthy lateral root of cotton plant magnified, but in proportion with Fig. 29.

Fig. 31. Galls on lateral root of cotton plant (natural size).

Fig. 32. Root-gall of peach, natural size, but small specimens.

Fig. 33. Section through female cyst in root of peach, showing the ultimate growth of soft, pseudo-parenchymatous tissue which sometimes entirely fills the cavity before the larvæ have all escaped; *a*, amorphous remains of female cyst, showing eggs and part of genital tubes; *b*, original outline of cyst; *c*, hypertrophied tissue from surface of cavity of cyst.

PLATE VI. Female cysts and structural effects of the disease in roots of the tomato, and the tubers of the potato (excepting Figs. 42—47). All magnified.

Fig. 34. Mature female cyst; *a*, exsertile spear; *b*, middle part of œsophagus; *c*, ovary; *d*, eggs escaped from the uterus.

Fig. 35. Mature female cyst of a different form.

Fig. 36. Cross section of diseased root of tomato; *a* and *b*, female cysts; *c*, dead cysts which probably failed to be fertilized.

Fig. 37. Section still more magnified; *a*, cyst cavity of female showing eggs and larvæ in amorphous remains of the parent; *b*, normal vascular tissue in cross section; *c*, deformed vascular tissue turned in a radial and tangential direction around the cyst.

Fig. 38. Section of outer portion of potato tuber showing *a*, female cyst external with head end only in the tissues; *b*, radial elongation of cells.

Fig. 39. Sexually immature larvæ making its way through cells of the potato tuber.

Fig. 40. Section of outer portion of potato; *a*, young cyst *in situ*; *b*, cork cells of lenticel (the section was through the side of a lenticel).

Fig. 41. Section of outer portion of potato tuber where decay of the tissues has begun; *a*, female cysts *in situ*; *b*, cyst cavity containing amorphous remains of parent, and young larvæ and eggs.

Fig. 42. Egg of 46; 43, cell division of same in process of development; 44, young larva in egg membrane; 45, young larva after hatching; 46, mature gravid female; *a*, mature egg; *b*, young ovum (Figs. 42—46 illustrate the egg, larva and mature female of the nematode, which produces the disease of the Irish potato characterized by Prof. Scribner).

Fig. 47. Mature female of a different genus found sometimes associated with the former.

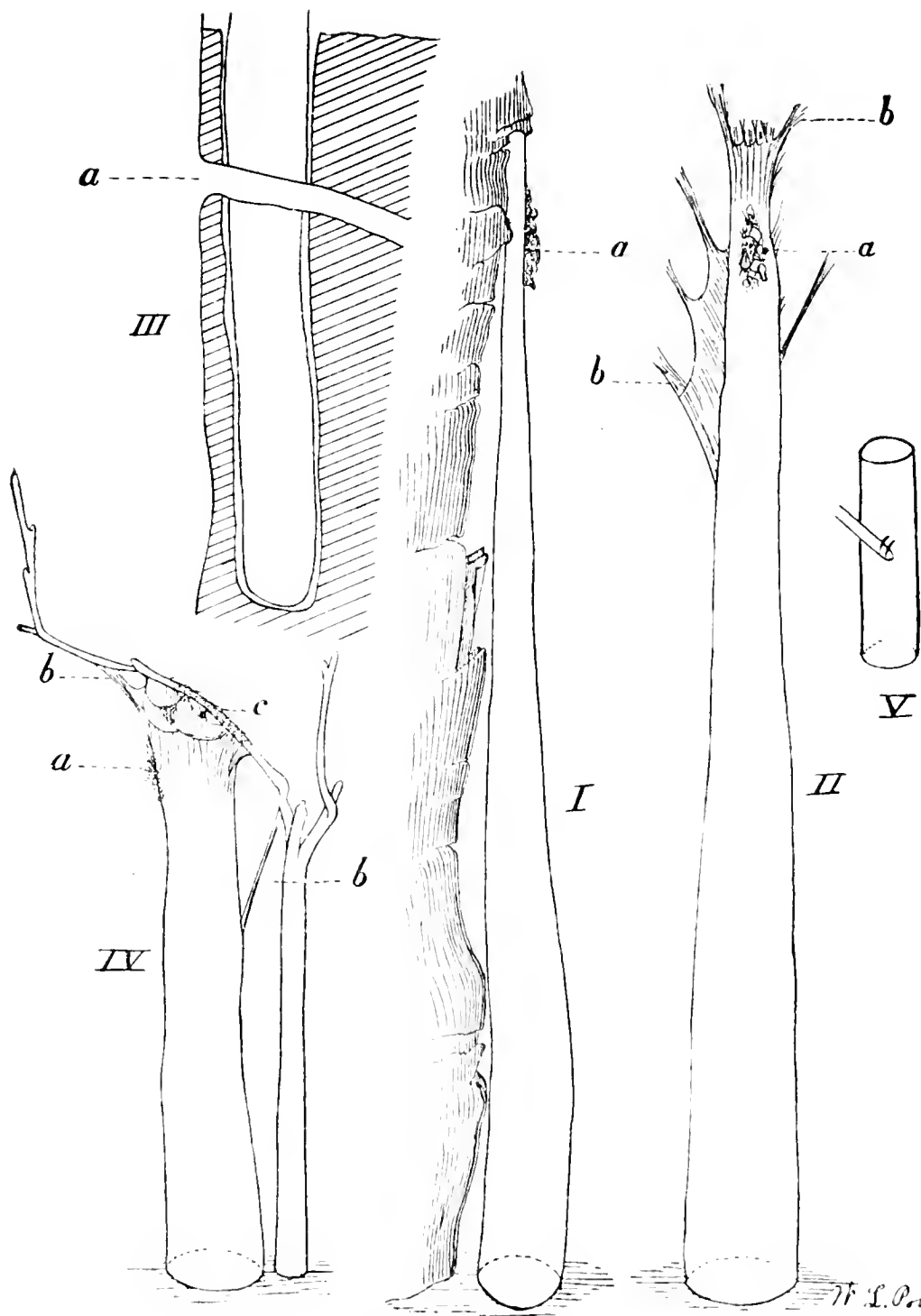

W. L. Petzold, del.

SKETCHES OF ATYPUS TUBES. (One-half natural size).

EXPLANATION OF PLATE.

FIG. I.—Aerial portion of a tube of *Atypus niger* Hentz (?), attached by its upper extremity to bark of pine tree—side view; *a*, remains of devoured insects adhering to the outside of the tube.

FIG. II.—Front view of the same tube, showing mode of attachment by brushes of silk, *bb*; *a*, insect remains.

FIG. III.—Subterranean portion of tube, showing that its walls are not adherent as a “lining” to the walls of the excavation; *a*, root of the supporting tree. Diagrammatic.

FIG. IV.—Aerial portion of a tube supported by a small persimmon shrub; *a*, insect remains; *bb*, attaching brushes of silk; *c*, silk threads enveloping the twig.

FIG. V.—Diagrammatic representation of the spider’s fangs thrust through the tube wall and grasping a fascicle of pine leaves.

A TUBE-BUILDING SPIDER.

NOTES ON THE ARCHITECTURAL AND FEEDING HABITS OF ATYPUS
NIGER HENTZ (?).

W. L. POTEAT.

Quite unaccountably American naturalists have taken comparatively little interest in spiders. Of all this neglected group the Atypinæ appear to have been most slighted. In our limited arachnological literature, so far as it has met my eye, when they are mentioned at all, it is with conspicuous brevity and often with a confession of doubt, if not of ignorance. Hentz himself, in his "Spiders of the United States,"* says: "The manner in which the spiders belonging to Mygale and Olerera [Syn. Atypus] live, hidden under ground, and probably issuing out only at night, prevents our becoming acquainted with their habits." Of Atypus in particular he says: "The habits of the animals of this subgenus are but little known." He seems to have erected the species which bears his name from observation of a single male individual. He probably never saw the tube of the female. Professor Emerton, in a private letter, says that they are rare, if they occur at all, north of Virginia. In his admirable little treatise on spiders† he says that a part of the tube of Atypus forms the lining of a hole in the ground, and part lies above the surface among stones and plants, and that the mouth of the tube is almost always closed, at least when the spider is full grown. Professor Comstock, of Cornell, quoting Mr. N. Banks, one of his assistants, writes me: "Their food is believed to be earth-worms. The tubes appear to be closed at both ends." And Professor Geo. F. Atkinson, of Alabama, who has probably given more attention to the Territelariæ than any other student in this country, says‡ that he has never seen Atypus or its nest, but

*Occas. Papers Bost. Soc. Nat. Hist., Vol. 4, pp. 18, 19.

†Spiders, Their Structure and Habits, p. 44.

‡Entom. Amer., Vol. 2, p. 116, note.

expresses himself inclined to believe that "the presence of a door or covering for the entrance to its nest, instead of being wanting, has been overlooked," and that in form of nest and in food habit it is very similar to his new genus *Nidivalvata*, which opens its folding trap-doors at night to watch for its prey and closes them in the morning.

European arachnologists are somewhat fuller and more definite in their statements. Ausserer reckons in the family *Atypinae* Thorell three genera,—*Pelecodon* Dol., *Calommata* Lucas, and *Atypus* Latr., and of *Atypus* six species. Touching the building habit of the family, he remarks* that they live in tubular webs under stones, in crevices in walls, or below the earth, the males wandering about. The nest of the genus *Atypus* he describes (p. 128) as destitute of a lid and simply tubular, and continues: "The part of the silk tube projecting out of the earth extends in protected places, under stones, etc., horizontally on the ground just a little way; its opening is not enlarged." Of *A. piceus* Sulz. (found in central Germany, Claus) Leunis† says that the females dig in the earth, mostly on sunny hill-sides, tubes which they line with silk and in which the lenticular eggsacks are fastened. Of the same species (*A. Sulzeri* Latr. and *A. piceus* Sulz. are synonyms) Latreille‡ says: "This species excavates a cylindrical gallery in sloping grounds covered with grass; in this gallery, seven or eight inches in length, horizontal at first and then inclined, it weaves a tube of silk of the same form and dimensions. The cocoon is fastened with silk by both ends to the bottom of the gallery." The late Rev. J. G. Wood§ makes about the same statement respecting the gallery, and adds: "The upper part of the tube is rather larger than the lower, and projects from the earth, falling forward so as to form a flap, which protects the mouth of the burrow." I infer that Rev. O. P. Cambridge alludes to *Atypus* when he says¶ that "at other times" the tubes of the *Territe-*

*Beitrage zur Kenntniss der Territelariae, p. 13.

†Synopsis der Zoologie, Vol. 2, p. 586 (Hanover, 1886).

‡Cuvier's An. King., Vol. 3, p. 178 (N. Y., 1831).

§Homes Without Hands, p. 131.

¶Encycl. Brit., Vol. 2, p. 295 (9th Ed.).

lariae are "closed by the falling over of a portion of the tube which protudes from the surface of the ground."

My own introduction to *Atypus* was largely accidental. On the 19th of July, 1886, in a small body of pine wood within the corporation limits of the village of Wake Forest, N. C., my attention was caught by a silk tube at the foot of a small pine tree. Being well covered with minute bits of bark, leaves, etc., it had nearly the appearance of the bark of the tree to which its upper end was attached, and, consequently, it was quite inconspicuous. Its greatest diameter—at the ground—was about 2 cm., and it showed above ground some 15 cm. The next day it was observed that the upper extremity had become detached from the tree and the whole aërial portion lay prostrate on the ground. The subterranean portion was 2 or 3 cm. long. At the lower end were the exuviae of the spider. The day following I pressed the spider out of the tube as it lay on the table.* For some time she walked about rather aimlessly, but finally coming upon the tube apparently by accident, she extended and raised her powerful fangs and with one stroke ripped a longitudinal slit and worked herself into it. The tube with the spider inside was put into a glass jar containing a little earth and dead pine leaves. The surface of the latter was not high enough to support the tube in a vertical position throughout its entire length, so that nearly half of it lay collapsed and wrinkled on the top of the leaves. The next morning the spider had lengthened the tube about 3 cm. upward from the point where it was bent from the vertical, and the addition had been made in such a way that it was smoothly continuous with the old portion below through a rent. Its upper end was attached to the glass. The old portion that lay horizontal on the leaves no longer communicated with the remodelled tube, though it remained attached to the outside of it. Two days later the tube had grown 6 cm. longer, tapering toward the upper end, very thin, and closed.

*Mr. N. Banks, assistant of Prof. Comstock, has determined the species as *Atypus niger* Hentz, but I am at present unable to feel quite satisfied that the determination is correct, seeing how meagre is the description which Hentz gives. The settlement of the question must be deferred until I have opportunity to compare the spider with other descriptions.

A house-fly with one wing removed was put into the jar. Soon after it touched the tube the spider appeared above the opaque portion of it, and, moving up only as the fly moved, she was soon separated from it by only the delicate wall of silk. Before I was aware she had made a hole in the wall and was drawing the fly in. She sank out of sight with her prey. Fifteen minutes later the rent through which the fly had been drawn was repaired.

After an absence of three weeks I found that my prisoner, left in the care of my wife, had further lengthened her tube and fastened its upper end to the small porcelain dish used to cover the jar. What is perhaps more interesting, she had attached to the outer wall of the new portion particles of trash, which made it less conspicuous. The refuse parts of flies fed to her in the meantime were found on the outside of the tube near its upper end. She was herself outside the tube on the leaves early in the day. When disturbed she raised her fangs with a show of fight. She seemed, however, to have become dissatisfied with her nest (because its situation supplied no moisture?*) and she did not care to retreat into it, but crawled up the side of the jar with its aid. With her fangs she struck a large fly placed near her, but did not care to eat it. After some hours she was in the tube again, but five days later she was found among the pine leaves dead.† My notes on my first *Atypus* close with this melancholy entry: "Alcoholic specimen, No. 17."

I have given the history of this specimen in captivity with so much of detail because every part of it, except the last, agrees with habits which I have since observed in natural conditions. That was the only specimen which I have seen outside of her tube of her own accord.

A number of other tubes were discovered in the same locality soon after the first. In the three years now passed I have seen in a very restricted area as many as thirty tubes varying from the size of a goose-quill to 3 cm. in diameter, four-fifths of them

*Cf. *Encycl. Brit.*, Vol. 2, p. 298 (9th Ed.).

†Cf. similar case of *Cteniza californica* leaving nest before death, E. Blanchard, *Pop. Sci. Mon.*, Vol. 33, p. 807.

being in a space not more than thirty yards square. The soil is a gray loam with red clay subsoil, and has not been cultivated, I suppose, in forty years. For a number of years past this bit of pine forest has formed part of a pasture for cows. The occurrence of the tubes elsewhere has been reported to me. Mr. Carey J. Hunter, an intelligent citizen of Raleigh, tells me that few objects on his father's farm near Apex, Wake county, N. C., were more familiar to him than these silk tubes. He remembers them most distinctly as supported by decaying oak stumps in cultivated fields. Many persons of whom I have made inquiries say that they have not seen them,—a fact which may probably be accounted for by the effective mimicry which the shrewd builder studies.*

As to choice of a support for the tube—in the case of this species in this locality always present and presumably indispensable—she is probably limited by what the locality supplies. That delightful “rambling naturalist,” Dr. Abbott, says that on one occasion a certain spider selected the end of his nose for the attachment of its thread, so long had he remained motionless in an intent observation. But *Atypus* is more reserved and cautious. With two exceptions, all the tubes I have seen were attached by their upper ends to pine trees varying from 3 to 35 cm. in diameter. Of the two exceptions, one, supported by a very small persimmon shrub, is figured in the Plate (Fig. IV); the other is supported by a wild rose.

The process of tube-building I have not observed in the natural situation, but it can hardly be widely divergent from that which I have observed in captive specimens. It may, therefore, be serviceable to record here the history of a tube made *de novo* in captivity and under conditions more nearly resembling the natural than in the case described above.

At 10 a. m., November 23d, I put a fine specimen, which had been taken from the pines the evening before, into a glass jar 28 cm. high, 5 cm. in diameter, and containing 14 cm. of damp

*Excepting the upper end, the white silk of the tubes is for the most part concealed beneath a loose exterior coating of bits of bark and leaves and small gravels and particles of earth. That these are collected outside of the tube is evidenced by the example of a large tube which is sparsely clothed with single leaves and tufts of leaves of a moss (*Atrichum*) near a bed of which it stands. Another tube is in its lower portion quite green with bits of a lichen (*Cladonia*) furnished by a neighboring cushion.

earth. The next morning she had done nothing toward the construction of a new home, but on the 25th she had made a brave beginning. From the surface of the earth there stretched up along the glass wall a delicate tube 7 cm. long and 1.8 cm. in diameter. At 10 a. m. she was offered a fly. She struck it through the tube wall with her fangs and seemed to kill it almost instantly, but for some reason she withdrew her fangs, letting the fly fall to the earth at the side of the tube. In a few minutes she was passing her long posterior pair of spinnerets here and there over the inner wall of the tube, but discontinued it after a minute or two. At 9 p. m. a shallow hole had been dug in the earth at the bottom of the tube directly beneath its cavity, and the excavated dirt had been put out through a rent near the upper end of the tube. The fly was nowhere to be seen. The next morning (November 26th) at 8 o'clock the excavation had been deepened some 3 cm. and turned obliquely to the left. More earth had been put out through the same rent. The spider, head up, was resting at the lower extremity of the tube. This stage in the construction of the tube is represented in the accompanying illustration (Fig. 1).

And so the next three nights the tube lengthened as the excavation deepened, the little dump heap growing proportionately. It was now 13 cm. long. For some 3 cm. below the middle it had left the glass wall, so that in that part of it a film of earth separated them; but in the upper and lower portions the wall of the jar, with hardly one continuous coat of silk, formed about one-fourth of the wall of the tube. The tube, however, was not a lining for the excavation. Evidently the excavation was made to receive the tube. See the diagram, Fig. III of the Plate. In one stretch of 4 cm. the wall of the tube was as much as 5 mm. from the wall of the excavation.

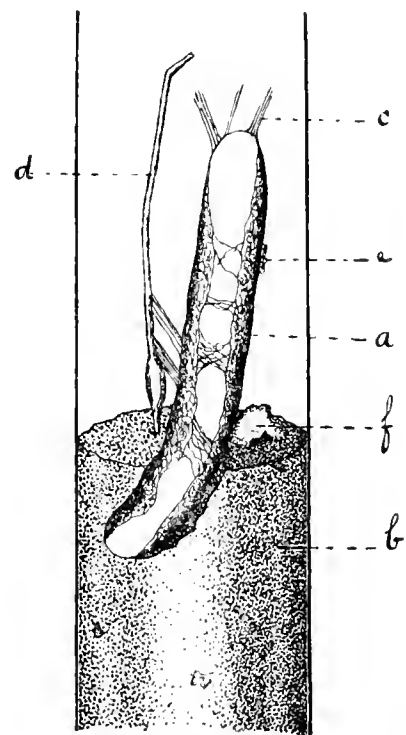

FIG. 1.— Beginning of tube and excavation of *Atypus niger* Hentz (?) in glass jar. *a*, the tube adhering by a portion of its wall throughout its length to the jar; *b*, earth partly filling jar; *c*, threads of silk attaching tube to jar; *d*, bit of weed stuck into the earth; *e*, hillock of excavated earth brought up through tube and dumped out at *e*. (About $\frac{1}{3}$ natural size. Drawn by the writer).

It was the 3d of December before any further change was observed. At the lower end the tube was then seen to be more nearly completed on the front side next the glass, and so much of the remaining wall as was visible was closely coated with earth. On the 6th the tube had been lengthened at the upper end, its growth up to this time having been at the lower end only. The addition was about 3 cm. in length and was supported by threads attached to the jar and the piece of weed (Fig. 1). That night at 8 o'clock I went cautiously into the room. Moonlight through a window fell on the jar, and one or two legs of the spider were seen above the opaque part of the tube. On my getting close for better observation, she disappeared below and refused to show herself again during the half hour that I waited. She was probably disturbed at her spinning, for the tube was open above and, though there was little or no addition to it since I last noticed it, the disposition of the uppermost threads was different. A lighted match held to the side of the jar enabled me on looking down the tube to see the spider below. The walls, slightly sinuous, were quite smooth on the inside. My conclusion that it was open preparatory to further extension was in a measure supported by the fact that on the following morning there was an upward extension of the tube of 5 mm., the end being loosely closed. A little water was poured into the jar to moisten the earth. This kindness seems to have been well received, for on the morning of the 9th I found that the tube had lengthened considerably at both ends. The upward extension was 5 cm., turning to the left; the downward, turning gently to the right, was about 5 cm. to the bottom of the jar and thence it followed the wall of the jar along the bottom a centimeter or two, the excavation without silk continuing 3 cm. further. The earth removed had been discharged through a rent near the upper end rather on the right side and fell down the slope of the previous dumpings to the left. There was little more excavation after this. Fig. 2 is a sketch of the tube at this stage.

On the night of the 11th at ten o'clock I found that the spider was not alarmed by the lamp held close to the jar. For two nights the jar had been in my study where a lamp had been burning until late. About eleven o'clock she several times pushed up a sort of flap at the point marked *e* (Fig. 2) and gathered earth from a tunnel pointing toward the end of the main excavation. She loosened and raked together the earth with her fangs. Hugging the little mass against the maxillæ with the same useful members, she ascended the tube to the level of a rent near its upper end, and with her breast against the tube wall, raked her load through the opening by outward movements of the fangs. She sometimes came up backwards, but reversed her position before discharging her burden.

At 12:30 a. m. she came up to one of the two rents which she had been using in this way, ascertained its limits, crawled on beyond so as to bring the spinnerets just over it, and then closed it. This was followed by considerable "plastering" up and down the tube, accompanied by stretching movements interpreted as intended to increase its calibre. I have observed that rents such as those spoken of above stand wide open, their edges showing no tendency to meet again after the separating force has been withdrawn. It is not unlikely that these stretching movements served to separate the silk threads composing the wall, stopping short, however, of rending it. New silk added would strengthen the points thus weakened, and the tube would re-

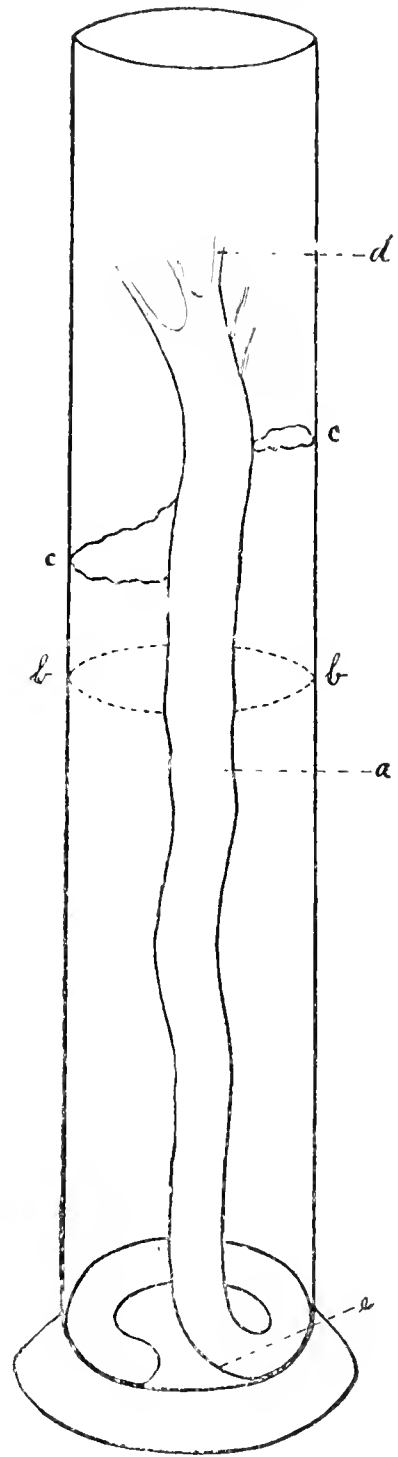

FIG. 2.—The same tube and excavation as in Fig. 1 after 15 days. *a*, tube coiling at lower end round the bottom of jar; *bb*, original level of earth; *cc*, surface made by excavated earth discharged through rents above; *d*, threads attaching tube to jar. (About $\frac{1}{2}$ natural size. Drawn by the writer).

tain its increased diameter. May it not be that the tube which accommodates the young spider is in this way enlarged to meet the demands of its subsequent growth?*

A little later this noiseless, industrious worker came up to repair the other rent, which she did indifferently. She was evidently finishing up her "job," and so she proceeded to take down her "scaffolding." Here and there the fangs were thrust through the wall of the tube and it was pulled inward and loosened from the wall of the excavation and from the glass, so that, excepting a limited area left adhering to the glass, the tube hung in the excavation. Inasmuch as the tube was not straight and was for the most part of nearly equal size with the excavation, it did not dangle, but was in light contact with it at numerous points.

I do not doubt that the history now given of this tube made in captivity is, with trivial variations, the history of the tube in its natural environment. The chief features of this history may be summarized:

1. The lower part of the aërial portion of the tube attached to the tree for support is the first to be made.

2. The excavation in the ground keeps but little in advance of the tube manufacture.

3. The earth from the excavation is brought up through the tube and dumped out through a rent near the upper end.†

4. The tube is usually placed in a nearly vertical position, any considerable departure from the vertical being made to avoid an obstacle.‡

*The conclusion that the spider spends her life in the same tube is not without warrant. One tube I had under observation for two years. In that period it was twice repaired. Having been by some means broken loose from its supporting tree, the fallen tube was not lifted to its place again, but was torn open at the bend on the surface of the ground and a new portion above ground, continuous with the old below, was built upward and fastened to the tree. (Cf. p. 136.) That this had been done twice was clear from the occurrence of two old prostrate portions attached to the tube as it stood. I cannot say certainly that it had increased in diameter. It may be mentioned, further, that while digging out a certain tube I discovered at different depths near the lower end two very short branches—cut-offs. The upper seemed worn and older than the lower. In each were found exuviae of the spider, legs and chelicerae. The fangs in the upper cut-off were 3 mm., in the lower 4 mm. So that this spider had dwelt in the same tube during the period between two successive moults, to which time should be added an indefinite period before the first moult and another after the second. (Cf. Blanchard, *Pop. Sci. Mon.*, Vol. 33, p. 806.)

†In the natural situation it is usual to see at the side of the tube on the ground a pile of earth evidently from below. In one such pile I found a gravel whose greatest length was 9 mm., and whose greatest width was 6 mm.

‡The subterranean portion of one tube was loosely spiral owing to the presence of two roots in its path, one above the other. I have seen but one tube whose aerial portion attached to the tree was not nearly vertical, and no satisfactory explanation of its exceptional position has occurred to me.

5. The tube is so constructed as to serve as a snare, and not merely as the silken lining of a "burrow." Being mainly supported by its upper extremity, its walls, for the most part free, readily transmit any mechanical disturbance up or down. See Plate, Figs. I and III.

6. The tube is closed above by the convergence of its walls in part, and in part by the simple approximation and adhesion of its outer wall to the supporting object.

7. The threads composing the walls are seen under the microscope to have a general longitudinal direction,—a fact which explains the ease with which longitudinal rents may be made.

8. Usually the greater part of the tube is above ground.*

9. The work appears to be done only at night.

The feeding habits of our spider may now be noticed. Rev. O. P. Cambridge† refers to E. Simon as authority for the statement that spiders sometimes prey upon earth-worms. I have not access to the journals in which the observations were reported, nor can I say that the reference is to the particular spider that concerns us here. Whether Mr. Banks' remark, quoted early in these notes, rests upon the same authority, or upon what authority it rests, I am not aware. But my own observations of *Atypus niger* Hentz (?) lead me to doubt that its "food is earth-worms." It is not improbable that so succulent a morsel would be appropriated in case it should come in the way; but it is improbable that the spider goes about to capture earth-worms, or that they are its chief reliance for subsistence. Nowhere in the nest have I noticed any feature of adaptation to this end. On the contrary, it is evidently constructed for the capture of insect food. The evidence is not merely inferential; it is positive as well, for I have looked on at the spider's feast and have seen the fragments that remained.

The behavior of my first captive specimen when a fly was crawling on her tube suggested to me that the disturbance made

*Measurements of a certain tube: Total length, 38 cm. Length of aerial portion, 21 cm. Length of subterranean portion, 17 cm. Diameter at surface, 2 cm.

†Encycl. Brit., Vol. 2, p. 298 (9th Ed.).

by an insect might be simulated by gently rubbing the tube with a tender twig. My first experiment in the pines received a speedy response. The spider came up by starts, her position in the opaque tube being shown by the slight bulging of its walls beneath her feet. This became my habitual method of ascertaining whether "my lady" was in. She seems unable to distinguish such disturbance from that caused by an insect. On one occasion I rubbed a tube with a fascicle of dead pine leaves. The spider came up and, the fascicle being kept at the same point, she thrust her fangs through the wall to grasp it, but failed. It was not long before she made another effort, that time seizing it firmly with both fangs and sustaining its entire weight (the three leaves were 15 cm. long) until I blew upon the tube, when she instantly let go and hurried below. She held the fascicle in the position indicated in the Plate, Fig. V. Her eyes can furnish little aid for the reason that the tube is not transparent, and the experiment just described suggests that the sense of smell is of no service. I conclude her habit is to try to catch whatever disturbs her snare in the hope that it will prove to be acceptable food, having ascertained its position by the sense of touch in her palpi and feet.

On the morning of August 21st I put a cockroach on a tube. The spider was soon up to the same level and, thrusting her fangs through the wall, caught one of the insect's legs. She seemed afterwards to hold it with her feet, for the fangs were seen striking through here and there in the neighborhood of the insect. They finally got a good grip on it. On my return after a few minutes I found that the spider had made a longitudinal slit 13 mm. long and was drawing the transversely placed cockroach into the tube. She had some difficulty in getting it in. Still holding it with her fangs, she pressed the lips of the rent out and over it with her feet. She dragged the insect below, and for fifteen minutes I saw nothing of her. I went away and returned after another fifteen minutes to find the rent repaired so perfectly that it could not have been detected by one who did not know its position. The same day a cockroach was similarly

taken by a spider in another tube. The fangs missed grasping it at the first "pass," and sounded against the polished segments of the abdomen as the finger-nail against silk.

Another example may be mentioned. On the 17th of the following October, after finding out that the tube was inhabited by gently stroking it with a pine leaf, I put on it a small field-cricket with one jumping leg removed. The spider came up and after some manœuvring inside the tube struck at the cricket, but it escaped. Another cricket was held on the tube by one of its legs. The spider seized it firmly with the fangs. The cricket seemed to be instantly paralyzed, for it made no struggle whatever. The hole in the tube was torn, I judge, by the feet, inasmuch as the fangs retained their grasp on the cricket. This longitudinal rent, 13 mm. long, was not repaired after fifteen minutes, but was repaired perfectly when I next saw the tube several days later.

I have already described the seizure of a house-fly by my first captive specimen. Another captive took a fly into her tube and closed the rent before going below with her prize. The spider whose tube is sketched in Fig. 2 caught a large blue-bottle December 16th, presumably in the same way. The fly was put into the jar and the jar closed. About three hours after, the fly had disappeared, and the next morning what remained of it after the spider had chewed it to her satisfaction was seen in a little ball on the outside of the tube near its upper end.

In further proof of the character of the food of *Atypus*, a word or two may be added about the leavings of her feasts. It is well-nigh invariable to find loosely adherent to the outer wall of the tube a little below its upper extremity (see Plate, Figs. I, II, IV, *a*) the remains of insects. These do not seem to be purposely attached to the tube, but to be put outside much as excavated earth is, and accordingly they are often seen on the ground at the foot of the tube. Those that adhere to the tube are probably caught by the silk fibres on the margin of the rent as they pass out. The leavings of a single feast are frequently seen to be bound together with silk. One tube, taken November 22d,

may be regarded as typical. On it I recognized the remains of some neuropter and of two different woolly-bear caterpillars, such as hair, bits of chitinous integument, a mandible, joints of leg, etc. Elytra of beetles are common.

Does *Atypus* leave her tube at night to stalk her prey in the open? I am inclined to think not, though the evidence which determines this inclination is for the most part negative and may be set aside by further observation. In the first place, she seems to be independent of that somewhat unsafe means of a livelihood, seeing that her tube is so well contrived and so effective a snare. The snare weavers are not usually hunters. Secondly, there is no special provision for egress, the tube being closed as described above. Such provision is usual with the other burrowing spiders that hunt on the outside of their burrows. Again, it will be remembered that the feeding experiments reported above were made in the day, and we may reasonably infer that under natural conditions the spider is not strictly nocturnal in her feeding habits. Moreover, my captive specimens have not been seen out of their tubes at night.* I have observed them in the fore part of the night, also in the early morning while it was yet dark. The one I now have rests habitually at night about the level of the earth in her jar, sometimes considerably above. On the other hand, the occurrence on a certain tube of the remains of a slender "thousand-legged worm" (*Julus*), devoured near the first of December, suggests, though it does not prove, that the spider left her tube to get it.

It will be observed that the description of the tube of *Atypus* given in these notes differs from that of Emerton, Wood, Auserer, and Cambridge, cited above. They represent its aërial portion as prostrate on the ground, serving only as a means of closing the subterranean burrow. I have, indeed, seen tubes in exactly the

*It ought to be said that *Atypus* is scrupulously neat, and accordingly the droppings of my captive are deposited outside the tube on the glass, and generally at such a distance as necessitates her leaving the tube. Additional ones have been observed only in the morning. It must be admitted, therefore, that she quits her tube at night at least for this purpose. (Cf. note on p. 138.)

position which Professor Emerton figures, but they had suffered violent severance from their proper supports. It is admitted that there is considerable variation in the architectural habit of tube-builders. The disagreement of the descriptions may, perhaps, be explained, therefore, as due either to specific or to local variations in the tubes described.

WAKE FOREST COLLEGE, N. C.,
DECEMBER 27, 1889.

RECORDS OF MEETINGS.

FORTY-SIXTH MEETING.

SEPTEMBER 17, 1889.

Prof. J. A. Holmes presided. The following papers were presented:

18. On Arkose. Prof. Holmes presented a short paper on the origin of Arkose deposits, and their distribution in the Triassic, Potomac and Appomattox formations in North Carolina and Virginia, and in other geological formations in different countries.

19. The Toronto Meeting of the American Association for the Advancement of Science. Professor Gore gave an outline of the business transacted at this meeting.

20. A Sketch of the Life and Work of Paracelsus. In this paper Dr. Venable discussed the main events in the career of Paracelsus, defending him from much of the abuse of his enemies and the accusations of later days. The sketch is to be concluded at the next meeting.

The Secretary reported many additional exchanges and large accessions to the library.

FORTY-SEVENTH MEETING.

OCTOBER 8, 1889.

The Society was called to order by Professor Holmes.

21. The first paper presented was a continuation of the Sketch of the Life and Work of Paracelsus, by Dr. Venable.

22. On Pasteur's Work in Connection with Hydrophobia. Mr. V. S. Bryant read extracts from letters by Professors Huxley and others, published in *Science*, concerning the great work done by Pasteur in the way of prevention and treatment of hydrophobia.

23. Corrosion and Fouling of Iron Ships. Mr. Gaston Battle gave in this paper an abstract of the address of Prof. V. B. Lewes before the Institution of Naval Architects. The causes of corrosion and fouling were discussed, and the present condition of the question of preventive compositions given.

24. Professor Holmes exhibited a number of early maps of the Carolinas, with explanations and remarks.

The Vice-President announced that the Society had lost by death during the past year the following members:

Prof. R. H. Graves, Chapel Hill.

Eugene Morehead, Esq., Durham.

Rev. Dr. Charles Phillips, Chapel Hill.

Benoni Thorp, Raleigh.

He further stated that arrangements had been made for a biographical sketch of Professor Graves by Professor Geo. T. Winston, and also one of Dr. Phillips by Col. W. J. Martin.

In Mr. Morehead the Society had lost a valued and helpful friend, but as his life had not been given to scientific pursuits, no sketch would be given in the Journal.

Mr. St. Clair Hester then read a biography of Mr. Thorp, which will be printed in the Journal.

The Society rose in token of respect for the members thus lost by death.

The Secretary reported one new exchange and seventy-one additional pamphlets and books received.

FORTY-EIGHTH MEETING.

NOVEMBER 12, 1889.

The Resident Vice-President, Prof. J. A. Holmes, presided and presented the first paper of the evening on

25. The Conglomerate and Pebble Beds of the Triassic and Potomac Formation in North Carolina. This paper was accompanied by an exhibition of numerous specimens from each. The conglomerates near Morrisville and on the Neuse River, in Granville county, were described, and it was shown that the character and distribution of the materials, the present topographic features of the region and the Raleigh *anticline* all go to prove that the conglomerates were deposited by rapidly moving currents of water flowing in a westerly direction at the time when the region to the east (about Raleigh) was much more elevated than now. It was further shown that the Potomac pebble beds were deposited on the Roanoke River, a few miles above Gaston, at a time when tide-water extended up to and covered this region.

26. The Metal of the Future—Aluminium, was the subject of the next paper, presented by Mr. H. L. Miller. In it an account was given of the recent improvements in methods of production, the comparative reduction of cost, the valuable properties and the possible uses of this metal. It was a valuable compilation of facts from the very latest sources.

27. The Allotropic Forms of Silver. In this paper Mr. J. S. Callison recounted some of the experiments and discoveries of Mr. Lea in this interesting line of research.

28. Saccharin. Dr. Venable gave a history of the discovery and of the manufacture of this body. Its chemical nature and physiological action were

discussed and the present position of the various governments of the world towards it was mentioned in detail.

The Secretary reported two new members :

Prof. W. A. Withers, Raleigh, N. C.

Prof. C. E. Brewer, Wake Forest, N. C.

During the past month one hundred and ten books and pamphlets were received.

FORTY-NINTH MEETING.

DECEMBER 3, 1889.

The Society was called to order by Prof. Holmes. He announced that Prof. Cain would read the first paper of the evening on

29. Preliminary Location of Railways as Affected by Topography.

Certain topographical features were first discussed—also crests of watersheds or ridges, gaps and saddles in ridges, streams and branches with their rates of fall in flat, hilly, and mountainous countries respectively, which generally determine the maximum gradients to use. Low points of ridges as “points in the line” were considered, such gaps generally being indicated by streams having their heads very near together and flowing in opposite directions, or by streams running near each other. Railway locations were then divided into *ridge* lines, generally the cheapest and easiest to maintain, lines running along the streams, giving often easy gradients, but with many culverts and bridges, lines crossing the general direction of the streams at right angles, and lines running obliquely across the streams and corresponding ridges, often giving the most expensive lines. Illustrations from the author’s experience were given of each character of line and the principles of location. The subject of locating railways in the mountains was next given, the subject of “making distance” to overcome the great elevations being illustrated by locations in Western North Carolina, across the Blue Ridge, in the Rocky Mountains, and across the Alps.

30. The Velocipede Railway was next described by Prof. Gore.

Some details as to construction and the results of experiments with this new style of railway were given and its advantages and disadvantages were compared with the present double-track road.

The following papers were read by title:

31. Addendum to the Minerals and Mineral Localities of North Carolina. By W. E. Hidden. (This paper appears in full in this Journal).

32. Nematode Root-Galls. By Prof. George F. Atkinson. (This paper is published in this Journal).

33. A Tube-building Spider. By Prof. W. L. Poteat. (This paper is published in this Journal).

The Secretary and Treasurer then presented their reports of those offices for the year. These reports are appended.

REPORT OF SECRETARY FOR 1889.

Nine meetings have been held during the year. The number of papers read at these meetings is thirty-three. The present number of members is ninety-two. The number of honorary members is ten.

The Society's exchange library shows most gratifying growth during the past year. A large number of regular exchanges have been added to the list, so that the total number now is 271. These come from eighteen different countries outside of the United States. They are as follows: From the United States, 150 exchanges; from Canada, 10; from Great Britain and Ireland, 18; from Germany, 34; from Austria, 7; from Belgium, 3; from Brazil, 1; from Chili, 1; from Mexico, 3; from the Netherlands, 6; from Italy, 7; from France, 8; from Russia, 6; from Switzerland, 10; from Sweden, 3; from Luxembourg, 1; from Japan, 1; from Portugal, 1; and from Argentine Republic, 1.

The total number of books and pamphlets at present in the Society's library is 3,521, and the monthly increase averages one hundred.

REPORT OF TREASURER FOR 1889.

Balance on hand January, 1889.....	\$ 26 15	
Fees of members for 1889	90 00	
Fees of members for 1890	6 00	
Fees of members for 1891	1 00	
Fees of associate members for 1889	5 50	
Fees of associate members for 1890.....	5 00	
Sales of Journals.....	2 00	
Contributions	100 00	
Printing Journal.....		\$145 00
Postage		19 68
Freight		1 60
Balance on hand December 3d, 1889		69 37
	<hr/>	<hr/>
	\$235 65	\$235 65

F. P. VENABLE,
Treasurer.

NECROLOGY.

RALPH HENRY GRAVES, C. AND M. E.

Prof. R. H. Graves was born at Hillsboro, April 1, 1851. He received his collegiate training at the University of North Carolina and the University of Virginia. He was elected to a professorship in the former institution in 1875 at the age of twenty-four and was connected with it down to the date of his early death. His specialty was mathematics, and he contributed many papers on this subject to the mathematical journals. He was one of the founders of the Mitchell Society, and, as its records show, was an active supporter and friend, holding several of the more prominent offices in the Society's gift. He died in Raleigh, N. C., at the early age of thirty-eight, July 10th, 1889.

EUGENE L. MOREHEAD.

Eugene L. Morehead, Esq., was born in 1845. He graduated at the University of North Carolina in 1868. He was a Confederate soldier. Settling in Durham he successfully followed the business of a banker and was very helpful in the building up of that town. He died in the early spring of 1889.

CHARLES PHILLIPS, D. D., LL. D.

Dr. Charles Phillips was born at Chapel Hill in 1822. He graduated at the University of North Carolina in 1841 and was tutor there from 1844 to 1854. In 1854 he was elected to the Professorship of Engineering, and in 1861 to that of Mathematics. He was a professor in Davidson College from 1869 to 1875, when he returned to the University. He was Professor Emeritus of Mathematics at the time of his death. The study of his life was mathematics, and he was widely known as a mathematician and a preacher of the Gospel of Christ. The Journal of the Society shows many articles from his pen, and he was one of its most loved and respected members. He died May 10th, 1889, at the age of sixty-seven.

BENONI THORP.

Benoni Thorp was born June 9th, 1868, in Granville county, N. C. He graduated at the University of North Carolina in 1888. Immediately after his graduation he was elected Assistant Chemist in the State Experiment Station. He contributed several papers to the Journal of the Society. He died of typhoid fever in Raleigh, July 23d, 1889, when only twenty-one years old.

LIST OF MEMBERS.

HONORARY MEMBERS.

1887. SPENCER F. BAIRD, Ph. D., LL. D.,†
Smithsonian Institution, Washington, D. C.
1885. H. CARRINGTON BOLTON, Ph. D.,
University Club, New York City.
1886. W. K. BROOKS, Ph. D.,
Johns Hopkins University, Baltimore, Md.
1885. A. W. CHAPMAN, A. M., LL. D.,
Apalachicola, Fla.
1886. W. M. FONTAINE, M. A.,
University of Virginia, Virginia.
1884. JOSEPH LE CONTE, M. D., LL. D.,
Berkeley, California.
1885. J. W. MALLET, M. D., LL. D., F. R. S.,
University of Virginia, Virginia.
1887. J. W. POWELL, Ph. D., LL. D.,
U. S. Geological Survey, Washington, D. C.
1886. H. W. RAVENEL, LL. D.†
Aiken, S. C.
1887. C. V. RILEY, M. A., Ph. D.,
Department of Agriculture, Washington, D. C.
1884. CHARLES U. SHEPARD,
Charleston, S. C.
1884. JAMES C. SOUTHALL, F. G. S.,
Richmond, Va.

CORRESPONDING MEMBERS.

1884. W. G. BROWN, B. S., Ph. D.,
W. & L. University, Lexington, Va.
1887. DAVID S. DAY,
U. S. Geological Survey, Washington, D. C.
1886. A. M. ELLIOTT,
Johns Hopkins University, Baltimore, Md.
1886. DANIEL L. GILMAN, LL. D.,
Johns Hopkins University, Baltimore, Md.
1884. JAMES LEWIS HOWE, Ph. D., M. D.,
Polytechnic Society, Louisville, Ky.
1887. J. M. MCBRYDE, LL. D.,
University of South Carolina, Columbia, S. C.

1887. W. J. MCGEE,
U. S. Geological Survey, Washington, D. C.
1884. G. E. MANIGAULT, M. D.,
College of Charleston, Charleston, S. C.
1885. J. M. PICKEL, Ph. D.,
State Agricultural College, Lake City, Fla.
1884. H. E. SHEPHERD, A. M.,
College of Charleston, Charleston, S. C.
1887. EUGENE A. SMITH, Ph. D.,
University of Alabama, Tuscaloosa, Ala.

REGULAR MEMBERS.

PROF. EBEN ALEXANDER	Chapel Hill, N. C.
PROF. GEO. F. ATKINSON, B. PH. ..	Columbia, S. C.
H. T. BAHNSON, M. D.....	Salem, N. C.
PRESIDENT K. P. BATTLE, LL. D.....	Chapel Hill, N. C.
K. P. BATTLE, JR., M. D.....	Raleigh, N. C.
H. B. BATTLE, PH. D.....	Raleigh, N. C.
R. H. BATTLE.....	Raleigh, N. C.
T. H. BATTLE.....	Rocky Mount, N. C.
PAUL B. BARRINGER, M. D.....	University of Virginia.
GEN. RUFUS BARRINGER.....	Charlotte, N. C.
PROF. J. R. BLAKE	Greenwood, S. C.
PROF. C. E. BREWER.....	Wake Forest, N. C.
COL. W. H. S. BURGWYN.....	Henderson, N. C.
CAPT. WILLIAM CAIN, C. E.....	Chapel Hill, N. C.
HON. P. C. CAMERON.....	Hillsboro, N. C.
JULIAN S. CARR.....	Durham, N. C.
J. C. CHASE.....	Wilmington, N. C.
HON. KERR CRAIGE	Salisbury, N. C.
F. B. DANCY, B. A.....	Raleigh, N. C.
PROF. J. R. DUGGAN, PH. D.†.....	Wake Forest, N. C.
H. E. FRIES.....	Salem, N. C.
J. W. FRIES.....	Salem, N. C.
PROF. J. W. GORE, C. E.....	Chapel Hill, N. C.
PROF. B. F. GRADY, JR.....	Albertson's, N. C.
PROF. R. H. GRAVES, C. AND M. E.†.....	Chapel Hill, N. C.
R. G. GRISSOM, B. S.....	Raleigh, N. C.
GEORGE B. HANNA.....	Charlotte, N. C.
WILLIAM H. HARDIN†	Raleigh, N. C.
J. R. HARRIS	Raleigh, N. C.
DR. S. J. HINSDALE.....	Fayetteville, N. C.
PROF. J. A. HOLMES, B. AGR.....	Chapel Hill, N. C.
PROF. J. H. HORNER.....	Oxford, N. C.

PROF. J. DEB. HOOPER†	Chapel Hill, N. C.
PROF. F. M. HUBBARD, D. D.†	Raleigh, N. C.
PROF. THOMAS HUME, JR., D. D.	Chapel Hill, N. C.
W. R. KENAN	Wilmington, N. C.
JAMES P. KERR	Haw River, N. C.
W. C. KERR, PH. D.†	Raleigh, N. C.
A. R. LEDOUX, PH. D.	New York City.
R. H. LEWIS, M. D.	Raleigh, N. C.
PROF. J. L. LOVE, B. A.	Chapel Hill, N. C.
DONALD MACRAE	Wilmington, N. C.
HUGH MACRAE	Wilmington, N. C.
HON. JOHN MANNING, LL. D.	Chapel Hill, N. C.
I. H. MANNING	Wilmington, N. C.
PROF. W. J. MARTIN, A. M.	Davidson College, N. C.
GERALD MCCARTHY	Raleigh, N. C.
PROF. W. H. MICHAEL	Wake Forest, N. C.
EUGENE MOREHEAD†	Durham, N. C.
PROF. W. H. PEGRAM	Trinity College, N. C.
PROF. CHARLES PHILLIPS, D. D.†	Chapel Hill, N. C.
HON. S. F. PHILLIPS	Washington, D. C.
PROF. W. B. PHILLIPS, PH. D.	Birmingham, Ala.
PROF. W. L. POTEAT	Wake Forest, N. C.
PROF. A. L. PURINTON	Wake Forest, N. C.
PROF. E. A. V. SCHWEINITZ, PH. D.	Washington, D. C.
PROF. A. M. SHIPP, D. D.†	Nashville, Tenn.
PROF. H. L. SMITH	Davidson College, N. C.
J. M. SPAINHOUR	Lenoir, N. C.
LIEUT.-GOV. C. M. STEDMAN	Wilmington, N. C.
GEORGE G. THOMAS, M. D.	Wilmington, N. C.
BENONI THORP†	Raleigh, N. C.
PROF. W. D. TOY, A. M.	Chapel Hill, N. C.
HON. Z. B. VANCE, LL. D.	Charlotte, N. C.
PROF. F. P. VENABLE, PH. D.	Chapel Hill, N. C.
COL. J. B. WHEELER†	West Point, N. Y.
J. F. WILKES	Charlotte, N. C.
MAJ. JAMES W. WILSON	Knoxville, Tenn.
PROF. GEORGE T. WINSTON	Chapel Hill, N. C.
PROF. W. A. WITHERS	Raleigh, N. C.
THOMAS F. WOOD, M. D.	Wilmington, N. C.
DAVID G. WORTH	Wilmington, N. C.

ASSOCIATE MEMBERS.

ANDREWS, WM. J.	Chapel Hill, N. C.
BATTLE, GASTON.	Chapel Hill, N. C.
BATTLE, WM. J.	Chapel Hill, N. C.

BRYANT, V. S.....	Chapel Hill, N. C.
CALLISON, J. S.....	Chapel Hill, N. C.
HARRIS, HUNTER L.....	Raleigh, N. C.
HESTER, ST. CLAIR.....	Chapel Hill, N. C.
LEE, T. M.....	Chapel Hill, N. C.
LEWIS, J. S.....	Chapel Hill, N. C.
LEWIS, J. V.	Chapel Hill, N. C.
MILLER, H. L....	Chapel Hill, N. C.
MOREHEAD, J. M.....	Chapel Hill, N. C.
RANKIN, CHARLES A.	Chapel Hill, N. C.
ROBERSON, W. S.....	Chapel Hill, N. C.
SHAFFNER, W. F.....	Chapel Hill, N. C.
SPOON, W. L.	Chapel Hill, N. C.
TOMS, C. W.....	Chapel Hill, N. C.
WILLS, GEORGE S.....	Chapel Hill, N. C.
WOODARD, P. L... ..	Chapel Hill, N. C.

LIST OF DONORS TO THE LIBRARY.

JAMES C. CHASE, ESQ.....	Wilmington, N. C.
MARCUS BENJAMIN, ESQ.....	New York City.
PROF. J. A. HOLMES.....	Chapel Hill, N. C.
DR. H. CARRINGTON BOLTON ..	New York City.
PROF. GEORGE DIMMOCK.....	Boston, Mass.
GEORGE F. KUNZ, ESQ.....	New York City.
PROF. W. J. MCGEE..	Washington, D. C.
DR. F. P. VENABLE	Chapel Hill, N. C.

LIST OF EXCHANGES.

UNITED STATES.

- ALBANY—New York Museum of Natural History.
 BOSTON—American Academy of Arts and Sciences.
 Boston Scientific Society.
 Society of Natural History.
 BROOKVILLE—Society of Natural History.
 CAMBRIDGE—Entomological Club.
 CHARLESTON—Elliott Society of Science and Arts.
 CINCINNATI—Society of Natural History.
 DAVENPORT—Academy of Natural Sciences.
 DENVER—Colorado Scientific Society.

- GRANVILLE—Denison Scientific Association.
 MADISON—Wisconsin Academy of Arts and Sciences and Letters.
 MANHATTAN—Kansas Academy of Natural Sciences.
 MERIDEN—Scientific Association.
 MILWAUKEE—Wisconsin Natural History Society.
 MINNEAPOLIS—Academy of Natural Sciences.
 NEW BRIGHTON—Natural Science Association of Staten Island.
 NEW HAVEN—Connecticut Academy of Arts and Sciences.
 NEW ORLEANS—Academy of Sciences.
 NEWPORT—Natural History Society.
 NEW YORK—Academy of Sciences.
 American Museum of Natural History.
 Linnean Society.
 Microscopical Society.
 Torrey Botanical Club.
 PEORIA—Science Association.
 PHILADELPHIA—Academy of Natural Sciences.
 American Philosophical Society.
 Franklin Institute.
 Wagner Free Institute of Science.
 PROVIDENCE—Franklin Geological Society.
 SACO—York Institute.
 SALEM—American Association for the Advancement of Science.
 Essex Institute.
 Peabody Academy of Science.
 SAN DIEGO—Society of Natural History.
 SAN FRANCISCO—California Academy of Sciences.
 ST. LOUIS—Academy of Science.
 TRENTON—Natural History Society.
 URBANA—Central Ohio Scientific Association.
 WASHINGTON—Chemical Society.
 National Academy of Sciences.
 Philosophical Society.

EDUCATIONAL INSTITUTIONS.

- JOHNS HOPKINS UNIVERSITY—Circulars.
 Studies from Biological Laboratory.
 HARVARD UNIVERSITY—Museum of Comparative Zoology.
 CORNELL UNIVERSITY—Bulletins.
 COLUMBIA SCHOOL OF MINES—Chemical Society.
 WASHBURN COLLEGE—Laboratory of Natural History.
 DENISON UNIVERSITY—Scientific Laboratories.
 UNIVERSITY OF MICHIGAN—Reports, etc.

OBSERVATORIES.

HARVARD UNIVERSITY OBSERVATORY—Cambridge.
 LEANDER McCORMICK OBSERVATORY—University of Virginia.
 LICK OBSERVATORY—Mount Hamilton.
 METEOROLOGICAL OBSERVATORY—Blue Hill.
 NAVAL OBSERVATORY—Washington.
 WARNER OBSERVATORY—Rochester.
 YALE OBSERVATORY—New Haven.

INDEPENDENT PERIODICALS.

BOTANICAL GAZETTE—Crawfordsville.
 MODERN LANGUAGE NOTES—Baltimore.
 THE MICROSCOPE—Trenton.
 POPULAR SCIENCE NEWS—Boston.
 NORTH CAROLINA MEDICAL JOURNAL—Wilmington.

BOARDS OF HEALTH, ETC.

MASSACHUSETTS—Boston.
 MICHIGAN—Lansing.
 NATIONAL—Washington.
 NEW YORK—Albany.
 NORTH CAROLINA—Wilmington.
 PENNSYLVANIA—Philadelphia.
 SOUTH CAROLINA—Columbia.
 TENNESSEE—Nashville.
 Wisconsin—Appleton.
 NORTH CAROLINA MEDICAL SOCIETY—Wilmington.
 NORTH CAROLINA PHARMACEUTICAL SOCIETY—Goldsboro.

AGRICULTURAL EXPERIMENT STATIONS, ETC.

ALABAMA—Auburn.
 ARKANSAS—Fayetteville.
 CALIFORNIA—Berkeley.
 COLORADO—Fort Collins.
 CONNECTICUT—New Haven.
 CORNELL UNIVERSITY—Ithaca.
 DAKOTA—Brookings.
 DELAWARE—Newark.
 GEORGIA—Athens.
 ILLINOIS—Champaign.
 IOWA—Ames.
 KANSAS—Manhattan.

KENTUCKY—Lexington.
 LOUISIANA—Baton Rouge.
 MARYLAND—Agricultural College.
 MASSACHUSETTS—Amherst.
 MICHIGAN—Agricultural College.
 MINNESOTA—St. Anthony Park.
 MISSISSIPPI—Agricultural College.
 MISSOURI—Columbia.
 NEBRASKA—Lincoln.
 NEVADA—Reno.
 NEW HAMPSHIRE—Hanover.
 NEW JERSEY—New Brunswick.
 NEW YORK—Geneva.
 NORTH CAROLINA—Raleigh.
 OHIO—Columbus.
 OREGON—Corvallis.
 PENNSYLVANIA—State College.
 SOUTH CAROLINA—Columbia.
 STORRS SCHOOL—Mansfield.
 TENNESSEE—Knoxville.
 TEXAS—College Station.
 VERMONT—Burlington.
 VIRGINIA—Blacksburg.
 WEST VIRGINIA—Morganton.
 ILLINOIS STATE LABORATORY OF NATURAL HISTORY—Champaign.
 MASSACHUSETTS HORTICULTURAL SOCIETY—Boston.
 MICHIGAN HORTICULTURAL SOCIETY—Grand Rapids.
 MINNESOTA HORTICULTURAL SOCIETY—Minneapolis.
 NORTH CAROLINA HORTICULTURAL SOCIETY—Raleigh.
 VIRGINIA DEPARTMENT OF AGRICULTURE—Richmond.
 DEPARTMENT OF AGRICULTURE—Washington.

GEOLOGICAL SURVEYS.

ALABAMA—Tuscaloosa.
 ARKANSAS—Little Rock.
 CALIFORNIA—State Mining Bureau, San Francisco.
 ILLINOIS—Springfield.
 INDIANA—Indianapolis.
 MINNESOTA—Minneapolis.
 NEW JERSEY—New Brunswick.
 NEW YORK—Albany.
 NORTH CAROLINA—Raleigh.
 OHIO—Columbus.
 WYOMING—Cheyenne.
 U. S. GEOLOGICAL SURVEY—Washington.

GOVERNMENT DEPARTMENTS.

FISH COMMISSION—Washington.
 NATIONAL MUSEUM—Washington.
 SIGNAL SERVICE BUREAU—Washington.
 SMITHSONIAN INSTITUTION—Washington.
 COAST AND GEODETIC SURVEY—Washington.
 SURGEON GENERAL'S OFFICE—Washington.
 DEPARTMENT OF STATE—Washington.

CANADA.

GRIMSBY—Fruit Growers' Association of Ontario.
 HALIFAX—Nova Scotian Institute of Natural Sciences.
 MONTREAL—Natural History Society.
 OTTAWA—Field Naturalists' Club.
 Royal Society of Canada.
 Geological Survey of Canada.
 Entomological Society of Ontario.
 PORT HOPE—Canadian Entomologist.
 TORONTO—Canadian Institute.
 WINNIPEG—Historical and Scientific Society.

GREAT BRITAIN AND IRELAND.

BELFAST—Naturalists' Field Club.
 BRISTOL—Naturalists' Society.
 DUBLIN—Royal Dublin Society.
 DUMFRIES—Natural History and Antiquarian Society.
 EDINBURGH—Royal Society of Edinburgh.
 GLASGOW—Geological Society.
 Natural History Society.
 HALIFAX—Yorkshire Geological and Polytechnic Society.
 LEEDS—Philosophical and Literary Society.
 LIVERPOOL—Geological Association.
 LONDON—Royal Society of England.
 MANCHESTER—Geological Society.
 Literary and Philosophical Society.
 NEWCASTLE—North Staffordshire Naturalists' Field Club.
 PENZANCE—Natural History and Antiquarian Society.
 Royal Geological Society of Cornwall.
 ROTHAMSTED—Agricultural Experiment Station.
 TRURO—Royal Institution of Cornwall.

ARGENTINE REPUBLIC.

BUENOS AYRES—La Sociedad Científica Argentina.

AUSTRIA.

- BRUNN—Der Naturforschende Verein.
 GRAZ—Der Naturwissenschaftliche Verein für Steiermark.
 PRAG—Die k. k. Gesellschaft der Wissenschaften.
 TRIESTE—La Societa Adriatica di Scienze Naturali.
 WIEN—Der Naturwissenschaftliche Club.
 Die Zoologisch-botanische Gesellschaft.

BELGIUM.

- BRUXELLES—La Société Royale Malacologique de Belgique.
 La Académie Royale de Medecine de Belgique.
 La Société Royale Linneenne.

BRAZIL.

- RIO DE JANEIRO—Museu Nacional.

CHILI.

- SANTIAGO—Der Deutsche Wissenschaftliche Verein.

FRANCE.

- AMIENS—La Société Linneenne de Normandie.
 ANGERS—La Société d'Etudes Scientifiques.
 AUXERRE—La Société des Sciences Hist. et Nat. de l'Yonne.
 CAEN—La Société Linneenne du Nord de la France.
 NIMES—La Société d'Etude des Sciences Naturelles.
 PARIS—Bulletin Scientifique de la France et de la Belgique.
 Le Laboratoire Municipal de Chemie.
 ROUEN—La Société des Amis des Sciences Naturelles.

ITALY.

- CATANIA—Accademia Gioenia di Scienze Natuali.
 NAPOLI—Societa Africana D'Italia.
 PADOVA—Societa Veneto-Trentina di Scienze Naturali.
 PERUGIA—Universita libera di Perugia.
 PISA—La Societa Toscana di Scienze Naturali.
 ROURA—R. Accademia dei Lincei.
 TORINO—Musee di Zoologia ed Anatomia Comparate.

JAPAN.

- TOKYO—Deutsche Gesellschaft für Natur und Völkerkunde Ostasiens.

LUXEMBOURG.

LUXEMBOURG—Société Botanique.

MEXICO.

MEXICO—Observatorio Meteorologico—Magnetico Central.
Sociedad Mexicana de Historia Natural.
Sociedad Cientifica “Antonio Alzate.”

NETHERLANDS.

AMSTERDAM—K. Nederlandse Akademie d. Wissenschaften.

HARLEM—Museum Teyler.

MIDDELBURG—La Société Hollandaise des Sciences.

NUMEGEN—Nederlandische Botanische Vereeniging.

UTRECHT—La Société Provinciale des Arts et des Sciences.

PORTUGAL.

LISBON—La Academie Royale des Sciences.

RUSSIA.

DORPAT—Die Naturforschende Gesellschaft.

HELSINGFORS—Societas pro Fauna et Flora Fennica.

KHARKOW—La Section Medicale de la Société des Sciences Experimentales.

KIEFF—La Société des Naturalistes.

MOSCOW—La Société Imperiale des Naturalistes.

ODESSA—La Société des Naturalistes de la Nouvelle-Russie.

SWEDEN.

LUND—Universitatis Carolinae Lundensis Acta.

STOCKHOLM—La Société Entomologique.

Sveriges Offentliga Bibliothek.

SWITZERLAND.

BASEL—Die Naturforschende Gesellschaft.

BERN—Die Naturforschende Gesellschaft.

CHUR—Die Naturforschende Gesellschaft Graubünden.

FRAUENFELD—Die Thurgauische Naturforschende Gesellschaft.

FRIBOURG—La Société Fribourgeoise des Sciences Naturelles.

GENEVA—L'Entomologiste Genevoise.

LAUSANNE—La Société Vaudoise des Sciences Naturelles.

ST. GALL—Die St. Gallische Naturwissenschaftliche Gesellschaft.

ZURICH—Die Naturforschende Gesellschaft.

International Entomologischer Verein.

PLATE I. — NEMATODE ROOT GALLS.

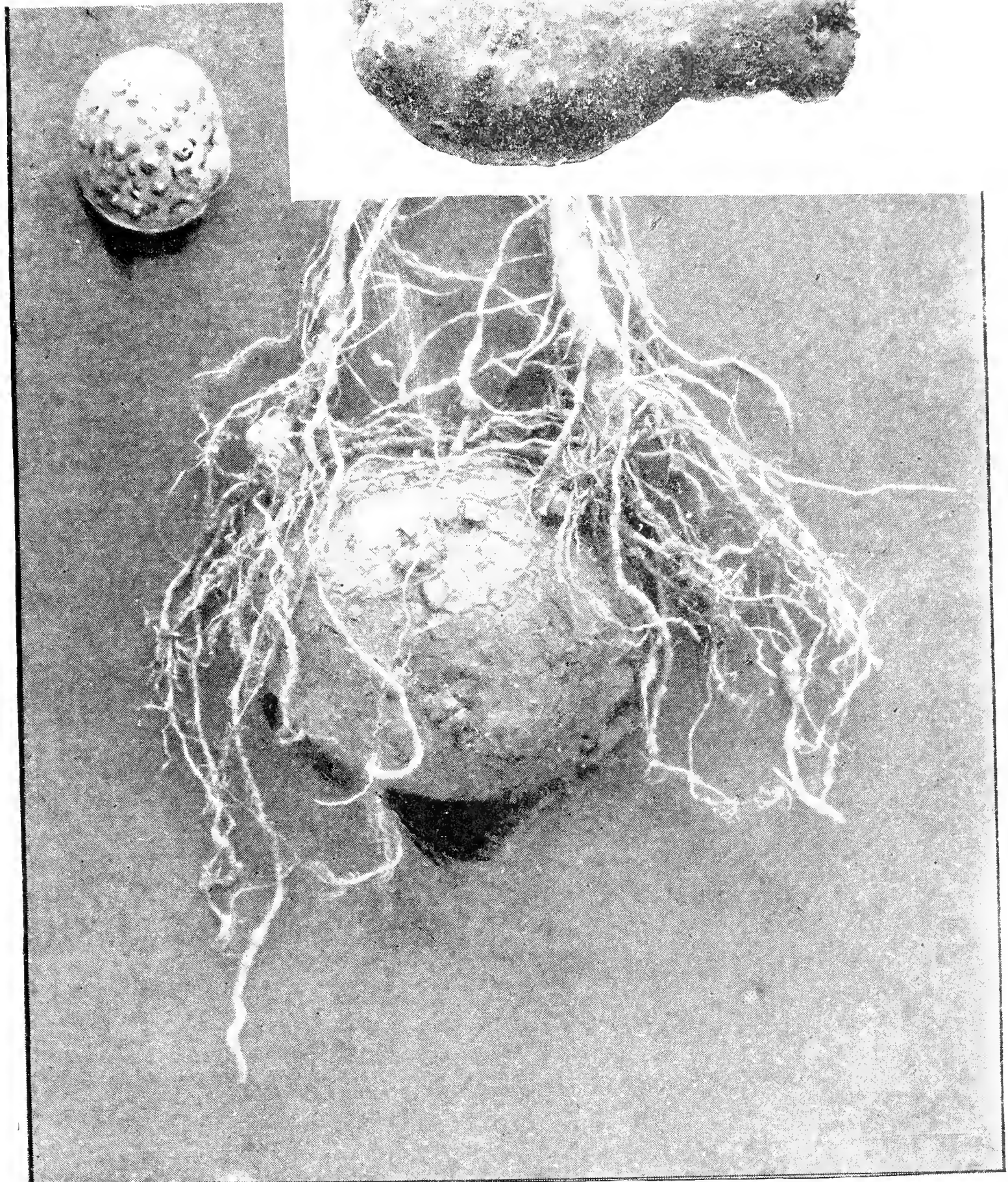

IRISH POTATO.

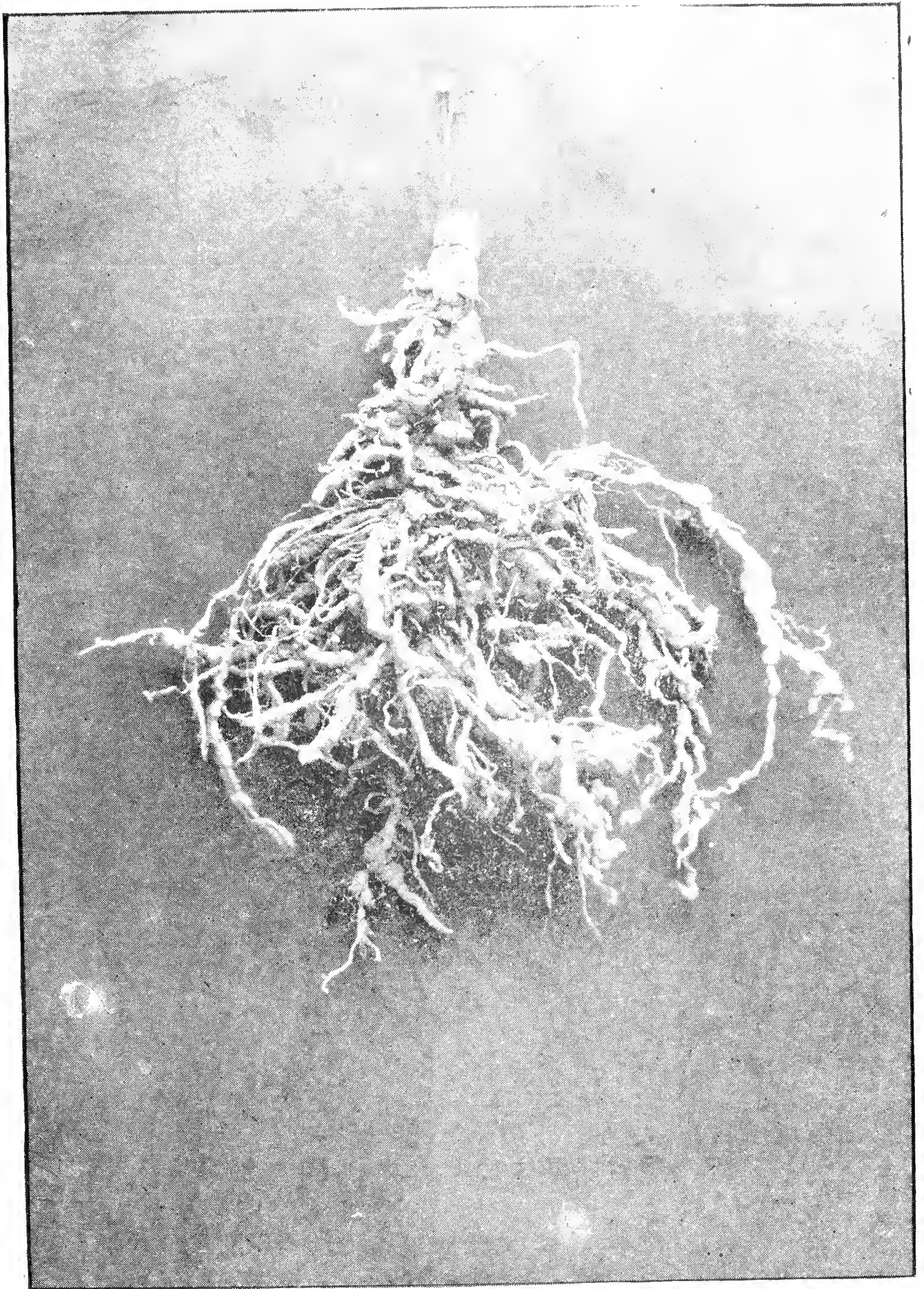

TOMATO

•

Q

7

Plate III

Nematode Root-Balls

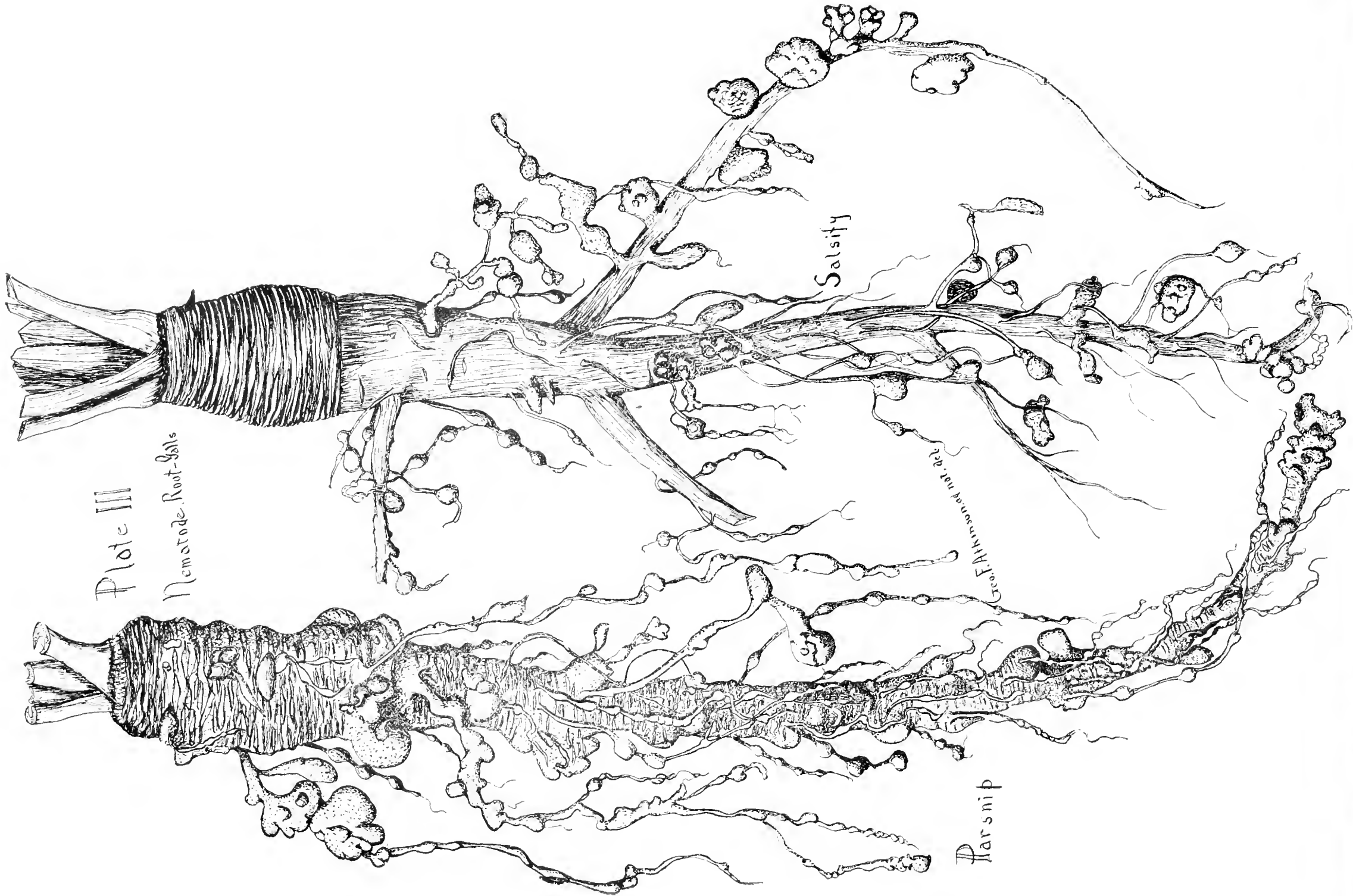

Salsify

Geo. F. Atkinson del. et. sculp.

Parsnip



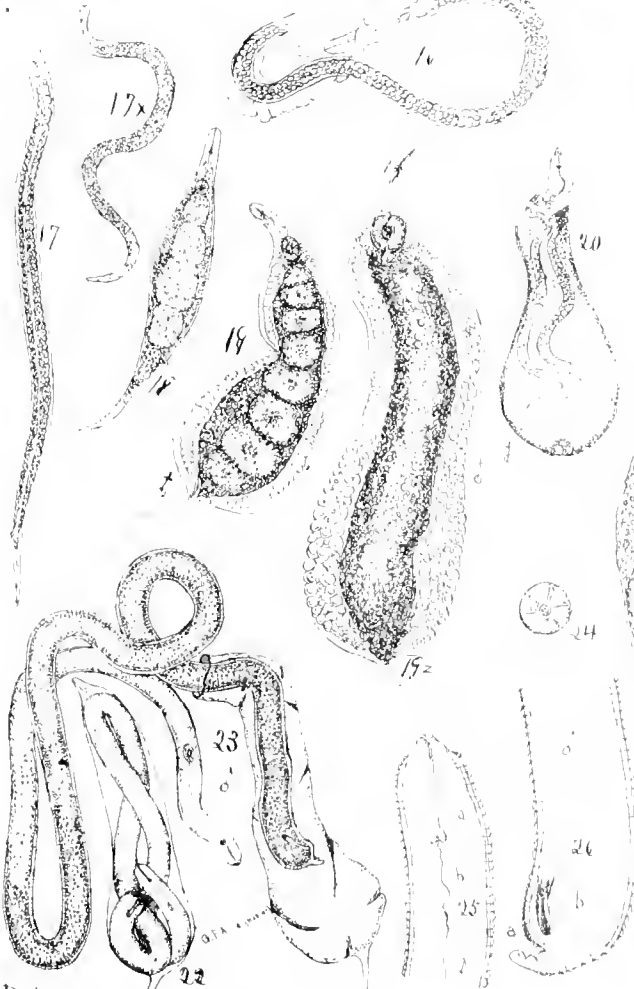
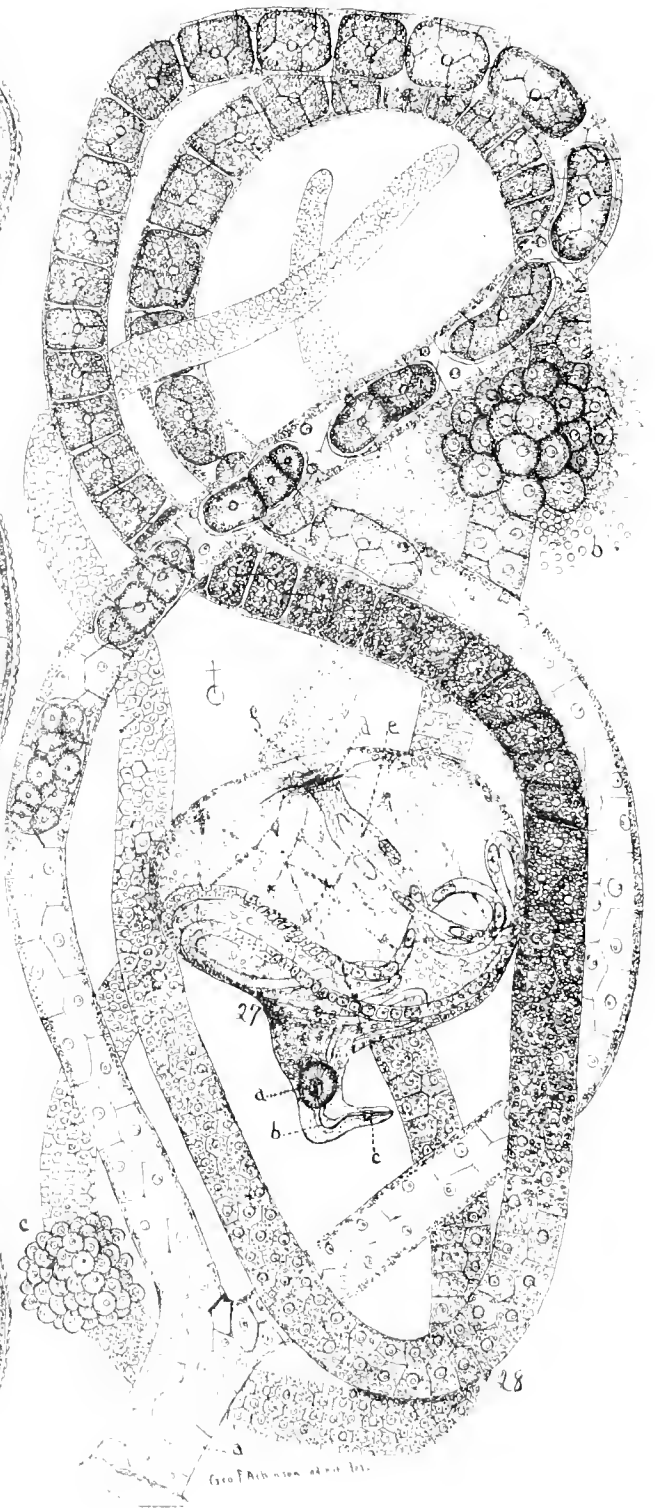
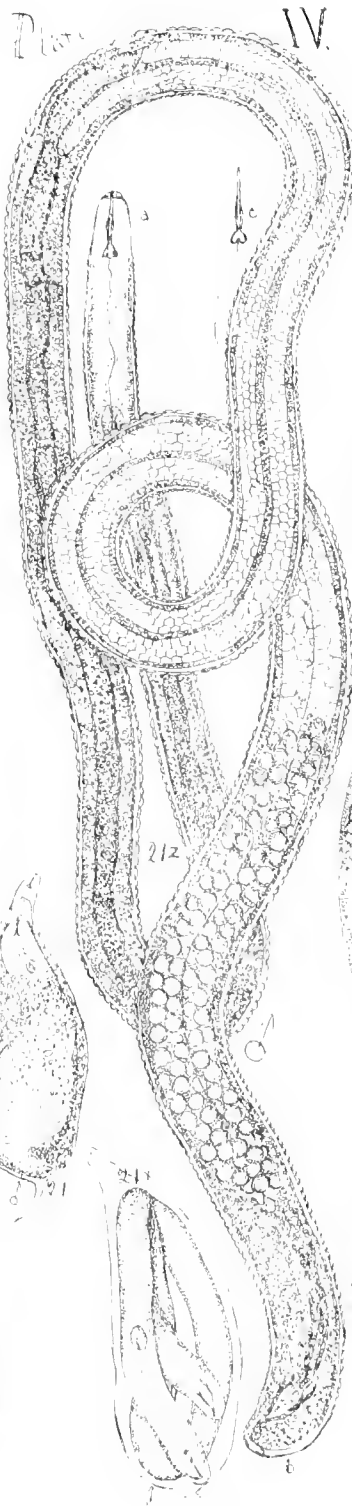
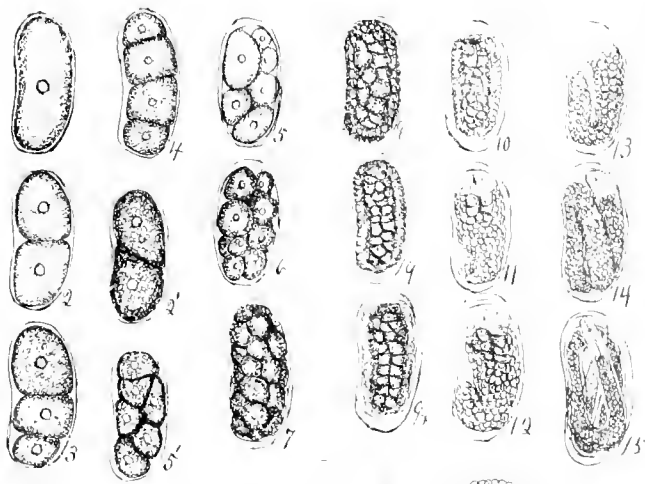

Development and Transformation of
Helicostephanus radiatus (Linn.) (Müll.) 1/22 26 II, 5/16

(Geo. F. Johnson del. et lit.)



Plate V

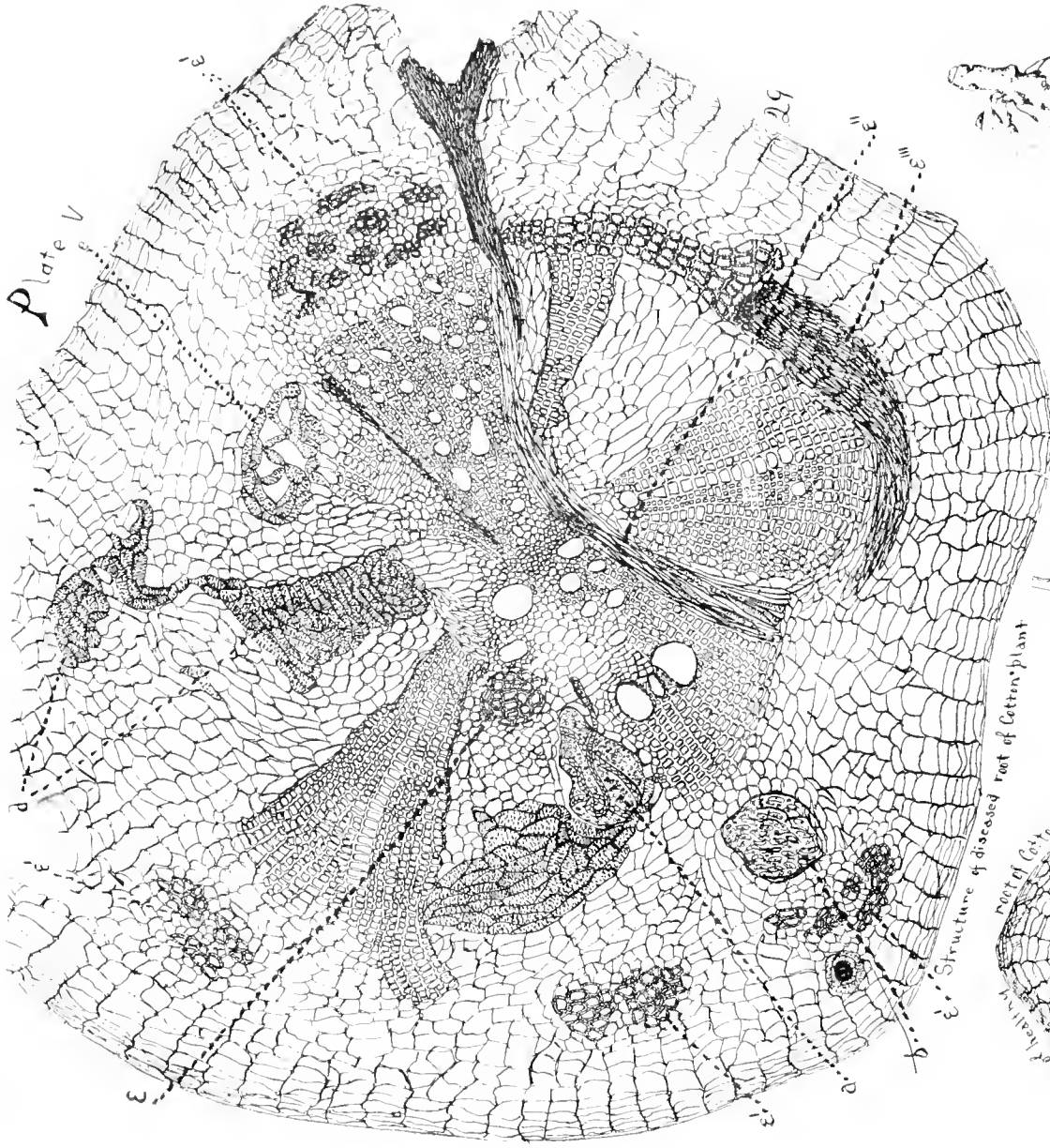
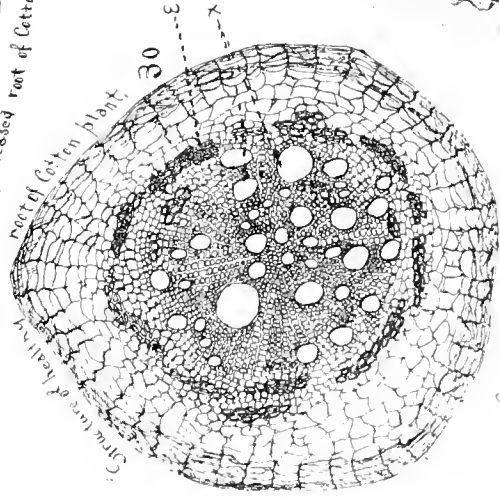
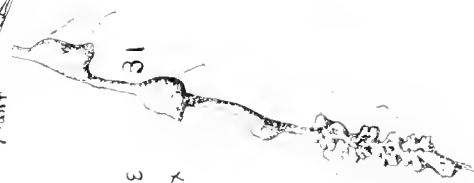

Fig. Structure of diseased root of Cotton-plant



Structure of healthy root of Cotton plant



31

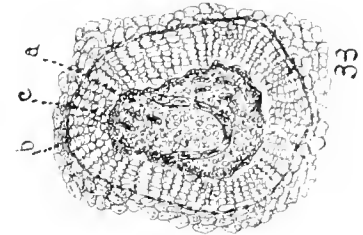

33



Peach

Geo. F. Atkinson del. et sculp.



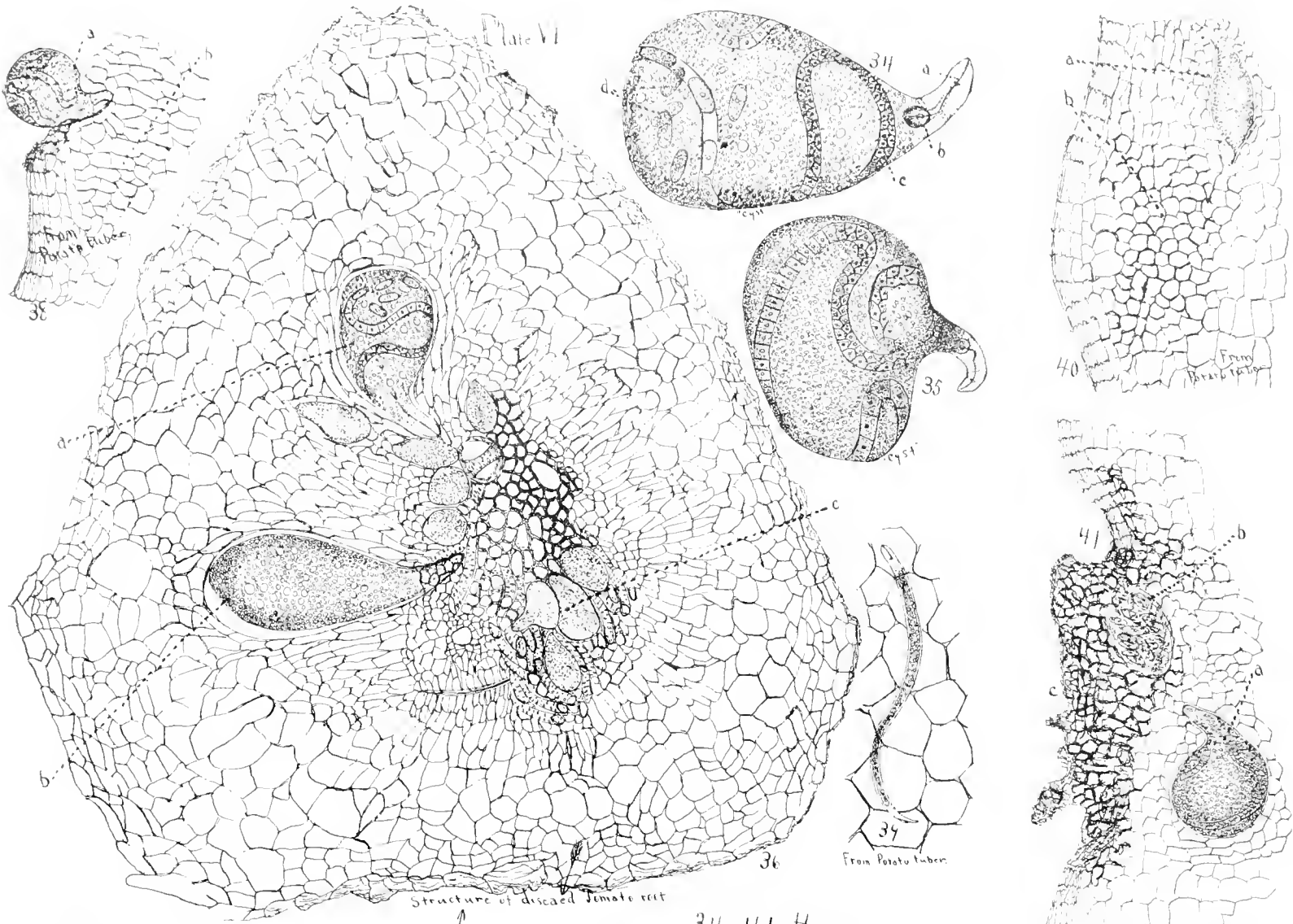

Structure of diseased potato root

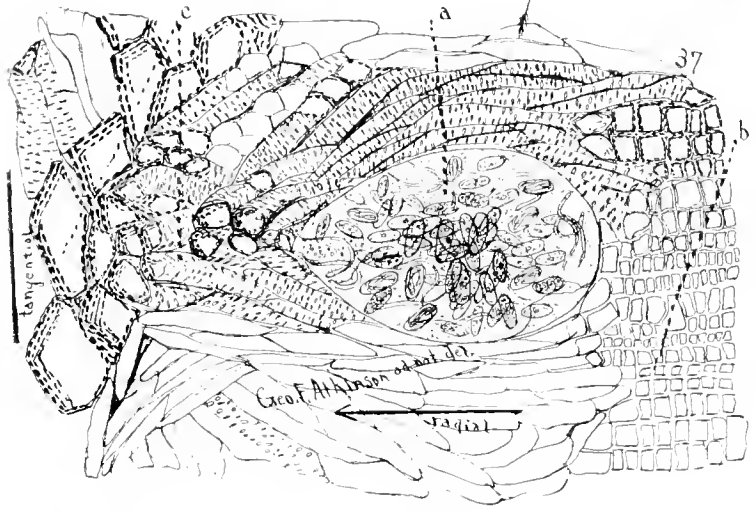

34-41 *Heterodera rad-*
icicola (Greeff) Mall.

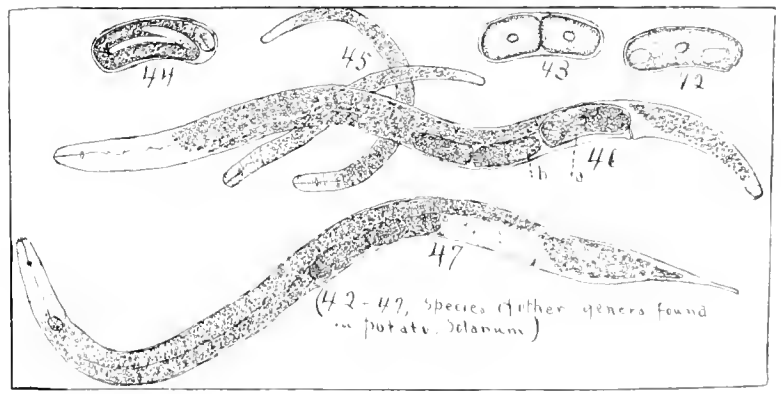

(42-47, species of other genera found in potato, Solanum)

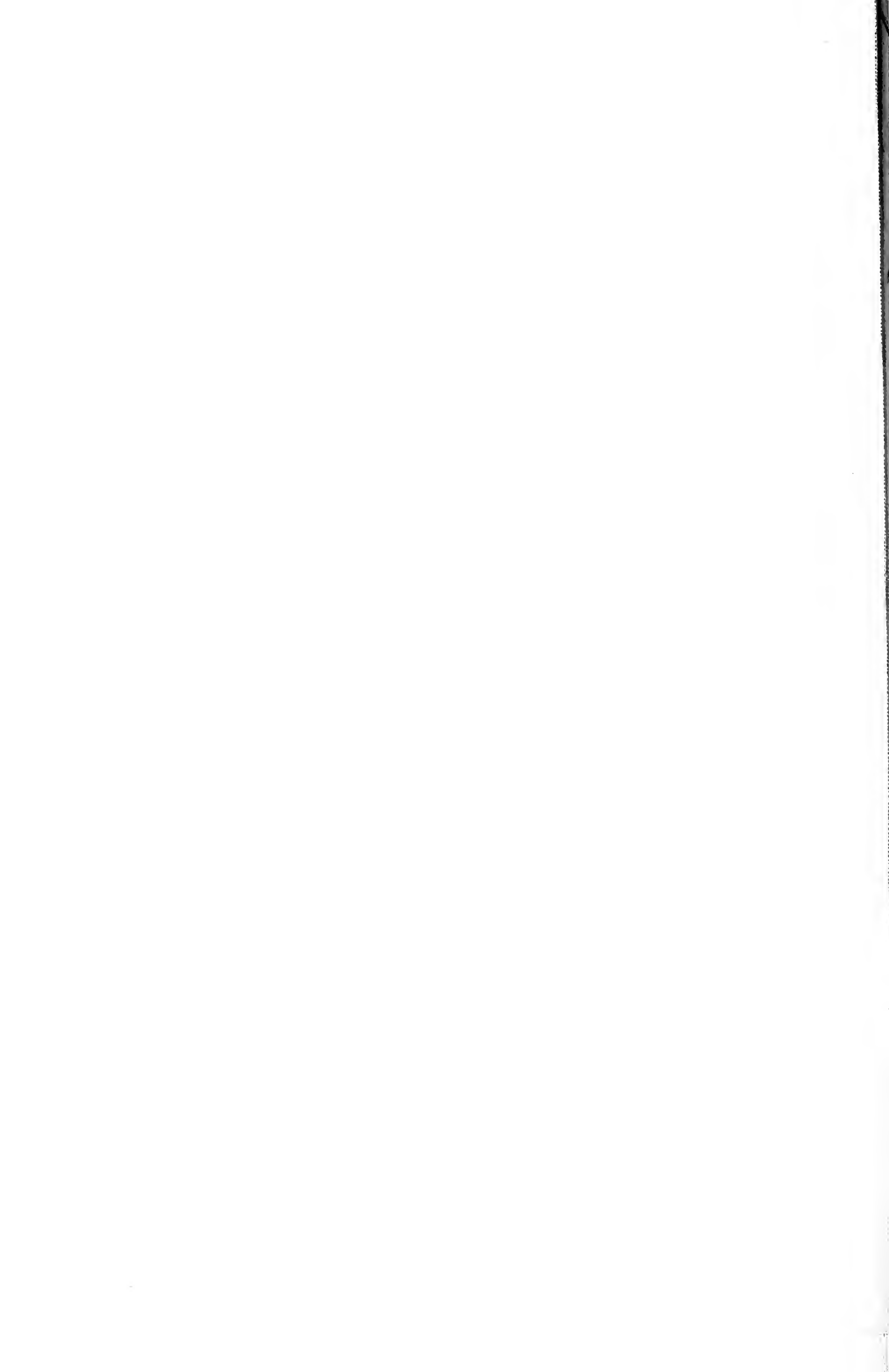



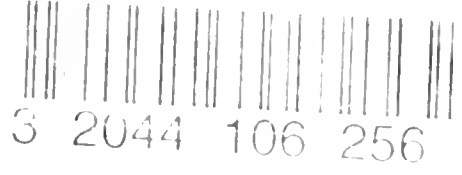

3 2044 106 256

